

# Autonics 2-Phase Closed-Loop Stepper Motor Driver AIS-D SERIES INSTRUCTION MANUAL

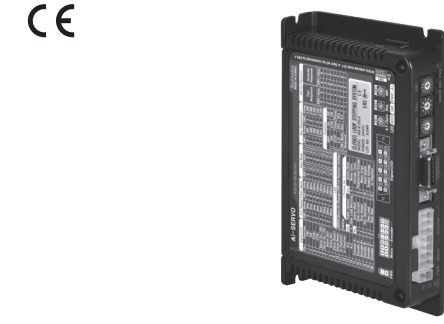

Thank you for choosing our Autonics product.  
Please read the following safety considerations before use.

## ■ Safety Considerations

- ⚠ Please observe all safety considerations for safe and proper product operation to avoid hazards.
- ⚠ symbol represents caution due to special circumstances in which hazards may occur.

- ⚠ **Warning** Failure to follow these instructions may result in serious injury or death.
- ⚠ **Caution** Failure to follow these instructions may result in personal injury or product damage.

## ⚠ Warning

- Fail-safe device must be installed when using the unit with machinery that may cause serious injury or substantial economic loss.** (e.g. nuclear power control, medical equipment, ships, vehicles, railways, aircraft, combustion apparatus, safety equipment, crime/disaster prevention devices, etc.)  
Failure to follow this instruction may result in fire, personal injury, or economic loss.
- Do not connect, repair, or inspect the unit while connected to a power source.**  
Failure to follow this instruction may result in fire.
- Install the unit after considering counter plan against power failure.**  
Failure to follow this instruction may result in personal injury, or economic loss.
- Check 'Connections' before wiring.**  
Failure to follow this instruction may result in fire.
- Do not disassemble or modify the unit.**  
Failure to follow this instruction may result in fire.
- Install the driver in the grounded housing or ground it directly.**  
Failure to follow this instruction may result in electronic shock, personal injury.
- Do not touch the unit during or after operation for a while.**  
Failure to follow this instruction may result in burn due to high temperature of the surface.
- Emergency stop directly when error occurs.**  
Failure to follow this instruction may result in fire, or personal injury.

## ⚠ Caution

- When connecting the power input, use AWG 18(0.75mm<sup>2</sup>) cable or over.**
- Install over-current prevention device (e.g. the current breaker, etc) to connect the driver with power.**  
Failure to follow this instruction may result in fire.
- Check the control input signal before supplying power to the driver.**  
Failure to follow this instruction may result in personal injury or product damage by unexpected signal.
- Install a safety device to maintain the vertical position after turn off the power of this driver.**  
Failure to follow this instruction may result in personal injury or product damage by releasing holding torque of the motor.
- Use the unit within the rated specifications.**  
Failure to follow this instruction may result in fire or product damage.
- Use dry cloth to clean the unit, and do not use water or organic solvent.**  
Failure to follow this instruction may result in fire.
- Do not use the unit in the place where flammable/explosive/corrosive gas, humidity, direct sunlight, radiant heat, vibration, impact, or salinity may be present.**  
Failure to follow this instruction may result in fire or explosion.
- The driver may overheat depending on the environment.**  
Install the unit in the well ventilated place and forced cooling with a cooling fan.  
Failure to follow this instruction may result in product damage and degradation.
- Keep metal chip, dust, and wire residue from flowing into the unit.**  
Failure to follow this instruction may result in fire or product damage.
- Use the designated motor only.**  
Failure to follow this instruction may result in fire or product damage.

## ■ Ordering Information

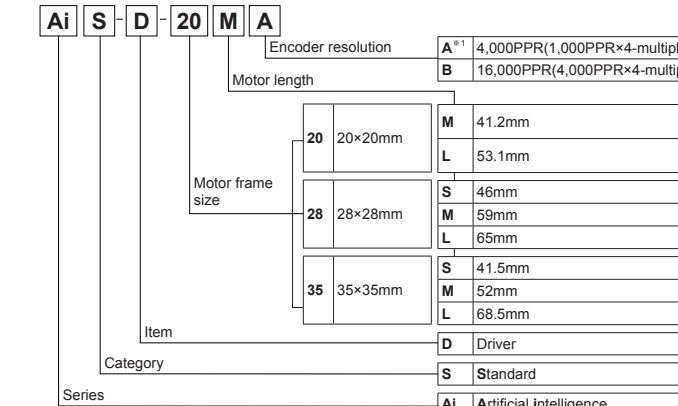

Set	Driver	Motor
AIS-20MA	AIS-D-20MA	AI-M-20MA
AIS-20LA	AIS-D-20LA	AI-M-20LA
AIS-28SB	AIS-D-28SB	AI-M-28SB
AIS-28MB	AIS-D-28MB	AI-M-28MB
AIS-28LB	AIS-D-28LB	AI-M-28LB
AIS-35SB	AIS-D-35SB	AI-M-35SB
AIS-35MB	AIS-D-35MB	AI-M-35MB
AIS-35LB	AIS-D-35LB	AI-M-35LB

※ The above specifications are subject to change and some models may be discontinued without notice.  
※ Be sure to follow cautions written in the instruction manual and the technical descriptions (catalog, homepage).

## ■ Specifications

Model	AIS-D-20MA	AIS-D-20LA	AIS-D-28SB	AIS-D-28LB	AIS-D-35SB	AIS-D-35MB	AIS-D-35LB
Power supply	24VDC=						
Allowable voltage range	90 to 110% of the rated voltage						
Power consumption (Max. during operation)	Max. 10W		Max. 60W				
Max. run current	0.6A/Phase		1.0A/Phase		1.2A/Phase		
STOP current	25% or 50% of max. RUN current (factory default: 50%)						
Rotation speed	0 to 3,000rpm						
Resolution	500 (factory default), 1000, 1600, 2000, 3600, 4000, 5000, 6400, 7200, 10000PPR		500 (factory default), 1000, 1600, 2000, 3600, 5000, 6400, 7200, 10000PPR				
Speed filter	0 (assable), 2, 4, 8, 10, 20, 40, 60 (factory default), 80, 100, 120, 140, 160, 180, 200ms (P Gain, 1 Gain) (1, (2), (1), (3), (1), (4), (1), (5), (1), (6), (1), (1), (2), (2), (3), (2), (4), (2), (5), (2), (1), (3), (2), (3), (3), (4), (3), (5), (3))						
Position control gain	Within the range of Fast response: 0 to 7 or Accurate response: 0 to 7						
In-Position	In-Position, alarm out (photocoupler output)						
Pulse input method	1-pulse or 2-pulse input (factory default) method						
Motor rotation direction	CW (factory default), CCW						
Status indicator	Power/Warning indicator: green LED			Alarm indicator: red LED			
Input signal	RUN pulse, Servo On/Off, alarm reset (photocoupler input)						
Output signal	In-Position, alarm out (photocoupler output), Encoder signal (A, Ā, B, B̄, Z, Z̄ phase, corresponding to 26C31) (line driver output)						

- CW, CCW : input pulse frequency duty 50% (min. 2μs)
- Servo On/Off: min. 1ms, Alarm reset: min. 20ms
- CW, CCW: input pulse frequency duty 50% (min. 1.25μs)
- Servo On/Off: min. 1ms, Alarm reset: min. 20ms

## ■ Dimensions

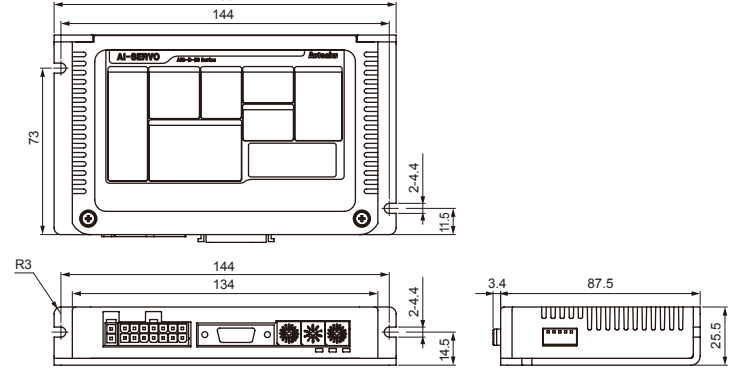

## ■ Driver Unit Descriptions

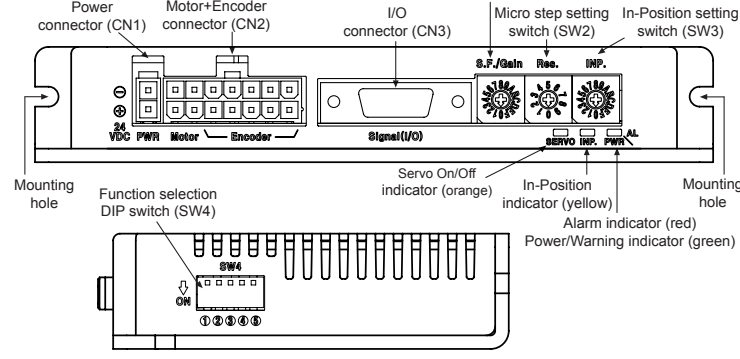

## ■ Driver Status Indicators

Status indicator	LED color	Function	Descriptions
PWR	Green	Power indicator	Turns ON when the unit operates normally after supplying power
AL	Red	Warning indicator	Flashes when over load status is maintained
INP	Yellow	Alarm indicator	When alarm occurs, it flashes in various ways depending on the situation. Refer to 'Control Input/Output' > 'Output' > 2. Alarm/Warning
SERVO	Orange	In-Position indicator	Turns ON when motor is placed at command position after positioning input.
		Servo On/Off indicator	Turns ON when Servo is operating, turns OFF when servo is not operating.

## ■ Connection Connectors of Driver

Pin arrangement	Pin No.	Function	Pin No.	Function
CN1: Power connector	1	GND	8	+5VDC
	2	24VDC	9	Encoder A
CN2: Motor+Encoder connector	1	GND	8	Encoder A
	2	Encoder B	9	Encoder A
	3	Encoder B	10	Encoder B
	4	Encoder Z	11	Encoder Z
	5	GND EARTH	12	N-C
	6	Motor A	13	Motor B
CN3: I/O connector	1	Input	11	Output
	2	Input	12	Output
	3	Input	13	Output
	4	Input	14	N-C
	5	Input	15	Output
	6	Input	16	Output
	7	Output	17	Output
	8	Output	18	Output
	9	Input	19	Output
	10	Input	20	Output

## ■ Driver Setting

- **SW1: Speed filter setting switch or position control gain setting switch**  
-SW1 shifts its mode between the speed filter or position control gain setting, depending on 4th pin in SW4 as follows.  
-Modified setting values are not applied in the running status, and the values will be applied after motor stopped.

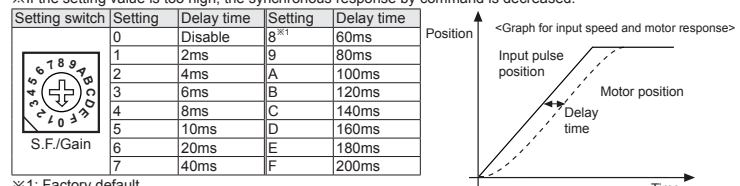

Setting switch	Setting	Delay time	Setting	Delay time	Position
S.F./Gain	0	Disable	B <sup>1</sup>	60ms	
	1	2ms	9	80ms	
	2	4ms	A	100ms	
	3	8ms	B	120ms	
	4	8ms	C	140ms	
	5	10ms	D	160ms	
	6	20ms	E	180ms	
7	40ms	F	200ms		

Setting switch	Setting	Gain	Setting	Gain
RES.	0	1	B <sup>1</sup>	3
	1	2	1	4
	2	3	1	A
	3	4	1	B
	4	5	1	C
	5	6	1	D
	6	1	2	E
7	2	2	F	

Setting switch	Setting	Frame size 20mm	Resolution	Frame size 28/35mm	Resolution
INP	0	500	2.5	500	2.5
	1	1000	5	1000	5
	2	1600	8	1600	8
	3	2000	10	2000	10
	4	3600	18	3600	18
	5	4000	20	5000	25
	6	5000	25	6400	32
	7	6400	32	7200	36
	8	7200	36	10000	50
9	10000	50	16000	80	

Setting switch	Fast Response	Accurate Response
INP	0	8
	1	±1
	2	±2
	3	±3
	4	±4
	5	±5
	6	±6
7	±7	

Setting switch	No.	Name	Function	Switch position	ON	OFF (factory default)
SW4	1	DIR	Rotation direction	CCW		
	2	1P/2P	Pulse input method	1-pulse input method		2-pulse input method
	3	C.D.	STOP current	25% of max. RUN current		50% of max. RUN current
	4	SW1 Mode	SW1 setting	Position control gain		Speed filter
	5	Reserved	Test mode	Test mode		Normal mode

Type	Specifications	Connector terminal	Housing	Manufacture
CN1	Driver	0039301020	—	Molex
	Power	CHD1140-02	CTD1140	HANLIM
CN2	Driver	35318-1420	—	Molex
	Motor+Encoder	5557-14R	5556T2	Molex
CN3	Driver	10220-52A2 PL	—	3M
	I/O connector	10120-3000PE	10320-52F0-008	Autonics

Type	Model
Power cable	CJ-PW- <sup>1</sup>
I/O cable	CJ-MP20-HP- <sup>2</sup>
Motor+Encoder cable	CJ-DF14M- <sup>3</sup>

※1: Indicates cable length (010, 020) E.g.) CJ-PW-010: 1m power cable  
 ※2: Indicates cable length (010, 020, 030, 050, 070, 100, 150, 200) E.g.) CJ-MP20-HP070: 7m I/O cable  
 ※3: Indicates cable length (1, 2, 3, 5, 7, 10) E.g.) CJ-DF14M-10: 10m moving type motor+encoder cable.

## ■ Control Input/Output

- Inner signal of all input/output consists of photocoupler.  
ON [H]: photocoupler power ON  
OFF [L]: photocoupler power OFF
- **Input**

- Position command pulse**  
-Pulse input is selectable from 1-pulse input method and 2-pulse input method. (Refer to 'SW4: Function selection DIP switch'.)  
-When using extending cable, it is recommended to connect Common mode choke coil (2mH) to the CW, CCW terminal in series connection.
- Servo On/Off**  
-This signal is for rotating axis of motor using external force or used for manual positioning.  
-Servo On/Off signal maintains over 1ms as [H]  
-Regarded as Servo Off signal and phase current is cut to release torque.  
-The Servo ON indicator, the In-Position output and indicator turns OFF.  
-Servo On/Off signal maintains over 1ms as [L]  
-Regarded as Servo On signal and phase current is supplied to gain torque.  
-The Servo ON indicator, the In-Position output and indicator turns ON.  
※Use this function after stopping the motor.  
※Refer to example of input circuit connection.
- Alarm Reset**  
-This signal is for clearing the alarm.  
-Alarm reset signal maintains over 20ms as [H]: Alarm is cleared, the alarm indicator and alarm output turns OFF, and the driver returns to normal status.  
※Refer to example of input circuit connection.
- Example of input circuit connection**  
• Input pulse (CW, CCW)  
-It is recommended to use 5VDC at V<sub>cc</sub> and short the R<sub>i</sub>.  
-In case V<sub>cc</sub> is over 5VDC, calculate R<sub>i</sub> value using following formula and use V<sub>cc</sub> below 30VDC.  
 $R_i = \frac{V_{cc} - 2.17V}{0.011A} - 220\Omega$   
-In case V<sub>cc</sub> is 12, 24VDC, refer to table on the right for R<sub>i</sub>.

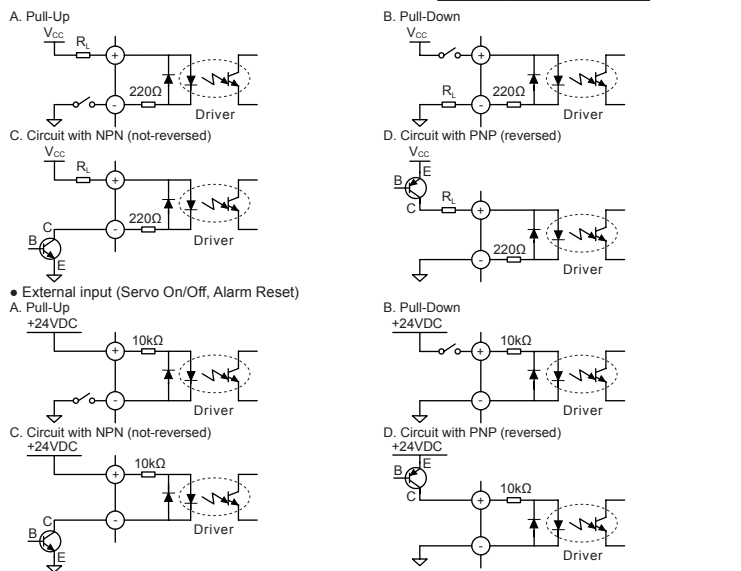

- **Output**
- 1. **In-Position**  
-In-Position output is output condition of positioning completion signal.  
-If the gap between target position and real position is under In-Position setting value, positioning completion pulse is output.  
-Modified setting values are not applied in the running status, and the values will be applied after motor stopped.
- 2. **Alarm/Warning**  
• Alarm  
-This function stops motor to protect driver, depending on the error status such as over current or over speed.  
-In case of normal status, output is [H], and in case of alarming status, output is [L].  
-When supplying alarm reset, driver returns to the normal status.  
※Refer to example of output circuit connection.

Alarm indicator	No. of flashing	Alarm type	Descriptions	Motor stop	Maintain torque
AL (red)	1	Over current error	When over current flows at motor RUN element	×	×
	2	Over speed error	When motor speed is over 4,000rpm	×	×
	3	Position tracking error	When the gap between position command value and current position value is over 90°	×	×
	4	Over load error	When applying load over the rated load for over 1 sec	×	×
	5	Over heat error	When driver inner temperature is over 80°C	×	×
	6	Motor connection error	When motor cable connection error occurs at driver	×	×
	7	Encoder connection error	When encoder cable connection error occurs at driver	×	×
	8	Regenerative voltage error	When regenerative voltage is over 78V	×	×
	9	Motor misalignment	When motor is in misalignment	×	×
	10	Command pulse error	When input pulse is over 3,500rpm	×	×
	11	Input voltage error	When input voltage is out of 21-27VDC ±5%	×	×
	12	In-Position error	When position error (over 1) is kept over 3 sec. after motor stopped.	×	×

- Warning  
-This function notices dangers with the alarm indicator prior to over load alarm.  
-When turning out from the alarming condition, driver returns to the normal status automatically.
- 3. **Example of output circuit connection**  
-It is recommended to use below 50VDC at V<sub>cc</sub>. Use the R<sub>i</sub> for I<sub>c</sub> (collector current of secondary detector) of photocoupler inside the driver to be within 25mA following the below formula.  
 $R_i = \frac{V_{cc} - 0.3V}{0.025A} - 10\Omega$     ※B, C, R<sub>i</sub> =  $\frac{V_{cc} - 0.3V}{0.025A} - 10\Omega$   
(V<sub>i</sub> is LED forward voltage of primary photocoupler.)

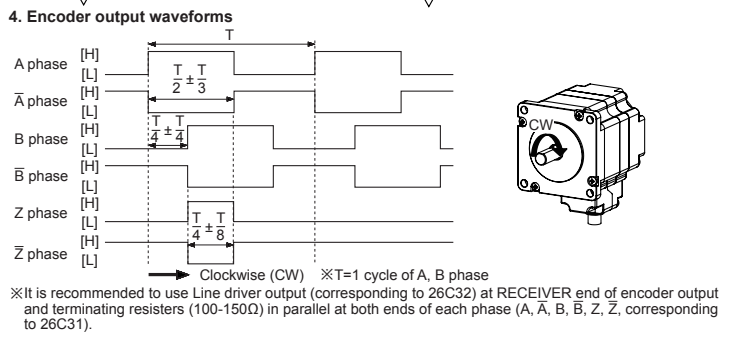
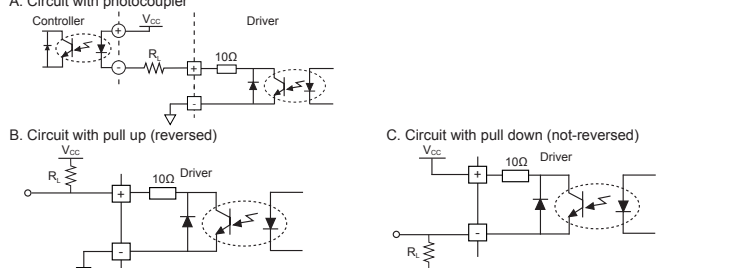

※It is recommended to use Line driver output (corresponding to 26C32) at RECEIVER end of encoder output and terminating resistors (100-150Ω) in parallel at both ends of each phase (A, Ā, B, B̄, Z, Z̄, corresponding to 26C31).

## ■ Connection for Motor and Driver

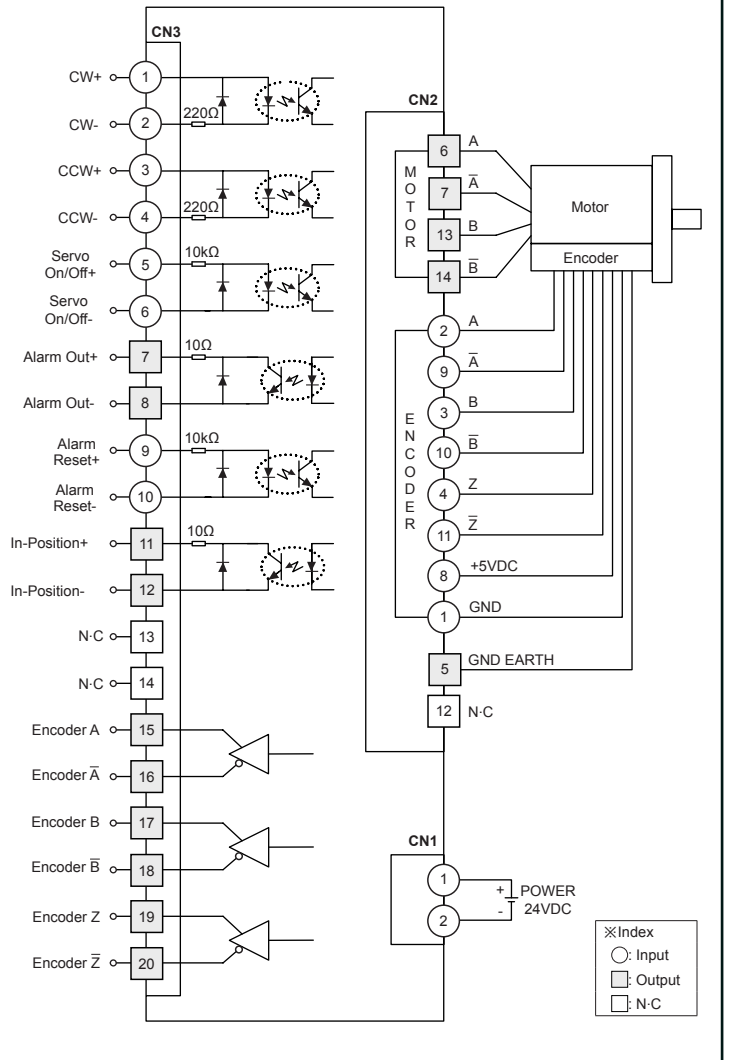

## ■ Troubleshooting

- When motor does not rotate**
  - ⊙ Check the connection status between controller and driver, and pulse input specifications (voltage, width).
  - ⊙ Check the pulse and direction signal are connected correctly.
- When motor rotates to the opposite direction of the designated direction**
  - ⊙ When RUN mode is 1-pulse input method, CCW input [H] is for forward, [L] is for backward.
  - ⊙ When RUN mode is 2-pulse input method, check CW and CCW pulse input are changed or not.
- When motor drive is unstable**
  - ⊙ Check that driver and motor are connected correctly.
  - ⊙ Check the driver pulse input specifications (voltage, width).

## ■ Cautions during Use

- Follow instructions in 'Cautions during Use'. Otherwise, it may cause unexpected accidents.
- 24VDC power supply should be insulated and limited voltage/current or Class 2, SELV power supply device.
- Re-supply power after min. 1 sec from disconnected power.
- Do not input CW, CCW signal at the same time in 2-pulse input method.
- When the signal input voltage is exceeded the rated voltage, connect additional resistance at the outside.
- Keep the thickness of cable should be same or thicker than the motor cable's when extending the motor cable.
- Keep the distance between power cable and signal cable more than 10cm.
- Motor vibration and noise can occur in specific frequency period
  - ⊙ Change motor installation method or attach the damper.
  - ⊙ Use the unit out of the dedicated frequency range when vibration and noise occurs due to changing motor RUN speed.
- For using motor, it is recommended to maintenance and inspection regularly.
  - ⊙ Unwinding bolts and connection parts for the unit installation and load connection
  - ⊙ Strange sound from ball bearing of the unit
  - ⊙ Damage and stress of lead cable of the unit
  - ⊙ Connection error with motor
  - ⊙ Inconsistency between the axis of motor output and the center, concentric (eccentric, declination) of the load, etc.
- This unit may be used in the following environments.
  - ⊙ Indoors (in the environment condition rated in 'Specifications')
  - ⊙ Altitude max. 2,000m
  - ⊙ Pollution degree 2
  - ⊙ Installation category II

## ■ Major Products

- Photoelectric Sensors
- Fiber Optic Sensors
- Door Sensors
- Door Side Sensors
- Area Sensors
- Proximity Sensors
- Pressure Sensors
- Rotary Encoders
- Connector/Sockets
- Switching Mode Power Supplies
- Control Switches/Lamps/Buzzers
- I/O Terminal Blocks & Cables
- Stepper Motors/Drivers/Motion Controllers
- Graphic/Logic Panels
- Field Network Devices
- Laser Marking System (Fiber, CO<sub>2</sub>, Nd: YAG)
- Laser Welding/Cutting System
- Temperature Controllers
- Temperature/Humidity Transducers
- SSRs/Power Controllers
- Counters
- Timers
- Panel Meters
- Tachometer/Pulse (Rate) Meters
- Display Units
- Sensor Controllers
- Sensor Controllers

**Autonics Corporation**  
http://www.autonics.com  
HEADQUARTERS: 18, Bansong-ro 513 beon-gil, Haeundae-gu, Busan, South Korea, 48002  
TEL: 82-51-519-3232  
E-mail: sales@autonics.com