



Multi-functional Power Meter DPM-C530A User Manual

Table of Contents

1. Preface	2
2. Notes	3
2.1 Safety Notes	3
2.2 Installation Environment	4
3. Descriptions of Parts	5
3.1 Operating Interface	5
3.2 Product Name Tag	5
3.3 Exterior and Dimensions	5
4. Installation	7
4.1 Installation Method	7
4.2 Basic Checks	9
5. Wiring Diagrams	10
5.1 Wiring on the Back	10
5.2 Descriptions of Wiring	11
6. Panel Display and Settings	13
6.1 Panel Display	13
6.2 General Operations	15
6.3 Setup Operations	16
6.4 Advance Setting	22
6.5 Power Analysis Values	25
7. Parameters and Functions	26
7.1 Overview of Parameters	26
8. Messages of Abnormal Operations	62
9. Specifications	64
9.1 Specifications	64
9.2 Communication Specifications	66
9.3 MODBUS Communication	66
10. Appendix	72
Appendix 1: Selecting Accessories	72

Preface

Thank you for choosing this product. This manual offers information related to installation of the DPM-C530A power meter. Before using the meter, please read this manual carefully to ensure proper use of this meter. Also, please place the manual at an easy-to-find location for reference at any time. Before you finish reading this manual, please observe the following notes:

- No water vapor, corrosive and flammable gas shall be present in the installation environment.
- Follow the instructions on the diagram for wiring the device.
- Grounding must be performed correctly and properly according to provisions from related regulations on electric work currently effective in the country.
- Do not disassemble the meter or alter its wiring with power connected.
- With power on, do not touch the power-connecting area to avoid electric shock.

If you still experience issues in the use, please contact your distributor or our customer service center. As the product gets updated and improved, modifications on the specifications will be addressed in the newest version of manual obtainable by contacting your distributor or downloading from the Delta Electronics website (<http://www.delta.com.tw/ia/>) .



Notes

2.1 Safety Notes

Always be aware of the following safety notes when installing, wiring, operating, maintaining, and checking the device.

◆ Notes on Installation

- » Install the power meter according to instructions on the manual. Otherwise, damage on the device might result.
- » It is forbidden to expose and use this product in a place present with matters, such as water vapor, corrosive and flammable gas. Otherwise, electric shock, fire, or explosion might result.
- » Do not install the meter in an environment with a temperature that exceeds range on the specification. Otherwise, inability of the meter to operate normally or damage on the meter might result.
- » Do not use the meter on an alarm console that might cause personnel injury or death, damage on the device, or system shutdown.

◆ Note on Wiring

- » Keep a good grounding on the grounded terminals, as improper grounding might cause abnormal communication, electric shock, or fire.

◆ Notes on Operation

- » Do not alter wiring with power turned on. Otherwise, electric shock or personnel injury might result.
- » Do not touch the panel with a sharp item. Otherwise, indentation on the panel might result, which causes the meter to not function normally.

◆ Maintenance and Check

- » Do not get to inside of the meter. Otherwise, electric shock might result.
- » Do not take the meter panel apart when the power is on. Otherwise, electric shock might result.
- » Do not touch the wiring terminals within 10 minutes after turning off power, as the remaining voltage might cause electric shock.
- » Do not block ventilation ducts when operating the meter. Otherwise, the meter will breakdown because of inadequate heat dissipation.

◆ Methods of Wiring

- » Do not use voltage that exceeds range specified for the meter. Otherwise, electric shock or fire might result.
- » When wiring, take apart the quick connector from the main meter body.
- » Connect only one cord on one plug on the quick connector.
- » For wrongfully forced unplug, recheck the connecting cord and restart.

◆ Wiring for Communication Circuits

- » Follow the standard specification on use of wires for communication wiring.
- » Length of communication wires should be within the specified standard.
- » Use correct grounding loop to avoid communication issues.
- » To avoid stronger noise interference that causes the meter to not operate normally, use an independent wiring slot to separate the communication cable for the meter from all power cords and motor power cords.

2.2 Installation Environment

Before installation, this product must be placed in its packaging box. If not used for a while, be sure to watch for the following when storing the meter, so that the product could be kept under the company's warranty coverage for future maintenance.

- Place the device in a dry location free of dust.
- Ambient temperature for the storage location must be within the range of -20° C to +70° C (-4° F to 158° F).
- Relative humidity for the storage location must be within the range of 5% to 95%, with no condensation.
- Avoid storing at an environment present with corrosive gas and liquid.
- Package properly and store on a rack or counter.
- Suitable installation environment for this product includes: place with no device that generates high amount of heat; place with no water drop, vapor, dust, and oily dust; place with no corrosive and flammable gas; place with no floating dust and metal particles; place with no shaking and interference from electromagnetic noise.

Descriptions of Parts

3.1 Operating Interface

DPM-C530A uses a LCD display that exhibits four pieces of measurement information on each page. Diagram below is an illustration of the interface.

Descriptions:

- | | |
|--------------------|--------------|
| A. Title | F. UP key |
| B. Area of display | G. DOWN key |
| C. PULSE light | H. ENTER key |
| D. FAULT light | |
| E. MENU key | |

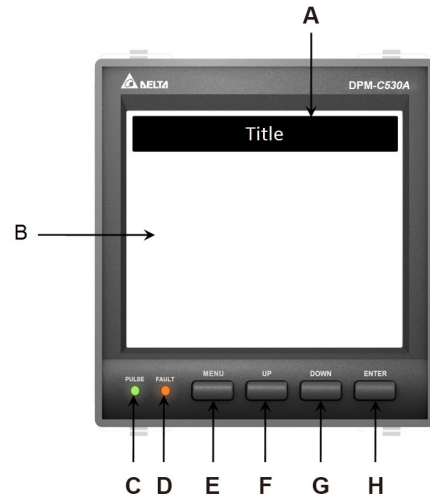

3.2 Product Name Tag

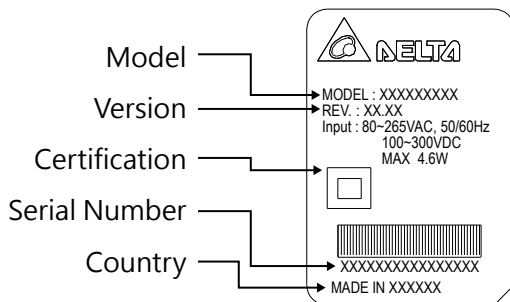

3.3 Exterior and Dimensions

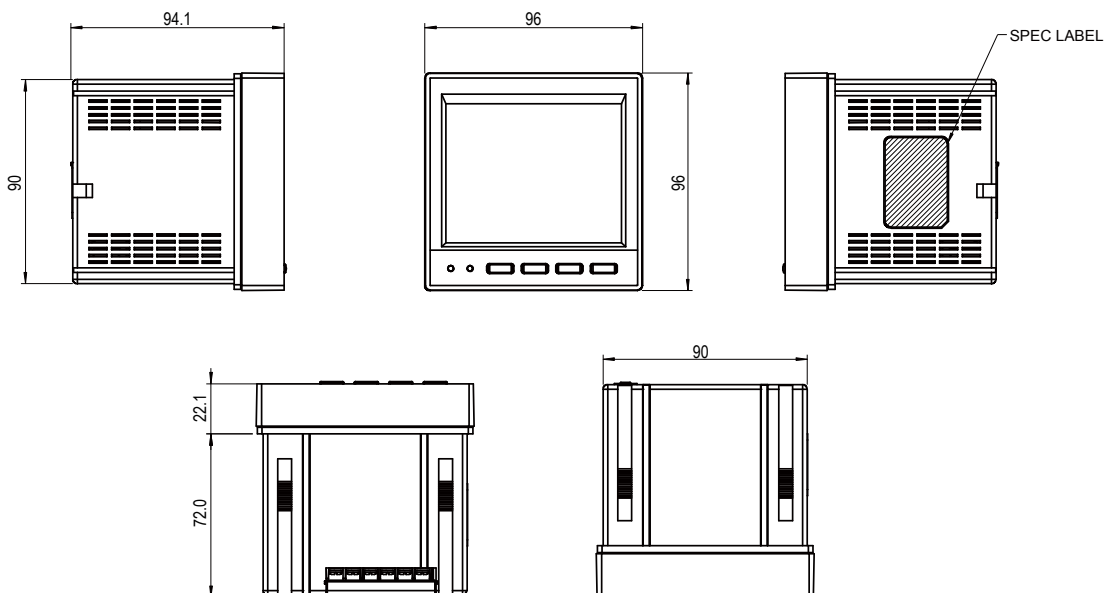

◆ Front

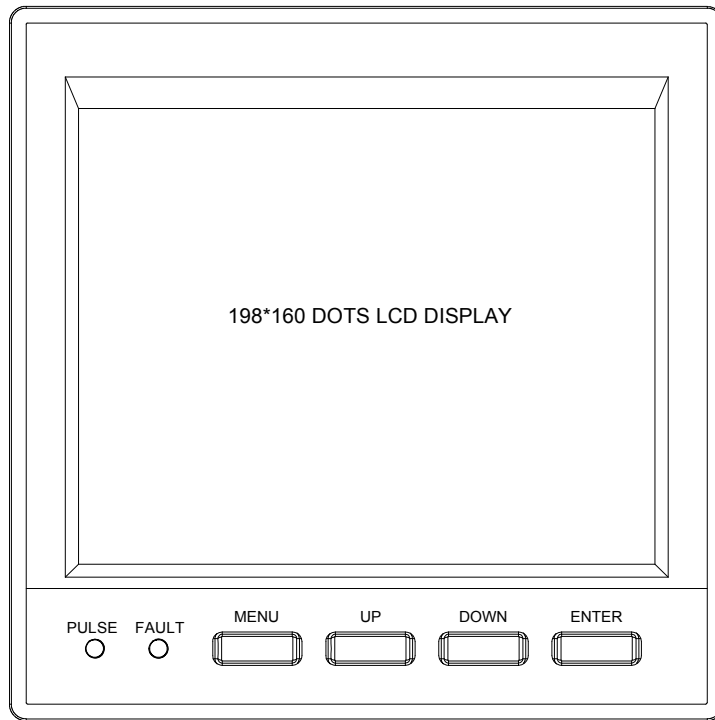

◆ Back

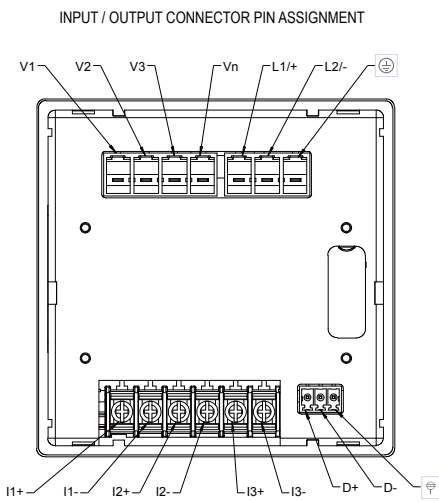

FUNCTION	PIN	VOLTAGE	CURRENT
MEASURED VOTAGE	V1	20V L-N ~ 400V L-N 35V L-L ~ 690V L-L	-
	V2		
	V3		
	Vn		
CONTROL POWER	L1/+	80 ~ 265 V _{AC} 100 ~ 300 V _{DC}	400mA MAX.
	L2/-		
	⊕		
MEASURED CURRENT	I1+	-	1A ~ 5A
	I1-		
	I2+		
	I2-		
	I3+		
	I3-		
RS-485	D+	-7 ~ +12 V _{DC}	-
	D-		
	⊕		

Installation

4.1 Installation Method

Note:

- The installation method should be based on instructions. Otherwise, breakdown would result.
- For better effectiveness of cooling cycles, sufficient space must be kept between adjacent objects and walls during the installation. Otherwise, imperfect cooling would result.
- Maximal thickness for the panel installed should not exceed 5 mm.

Illustration of Installation:

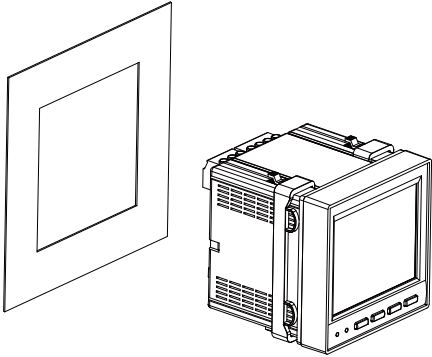
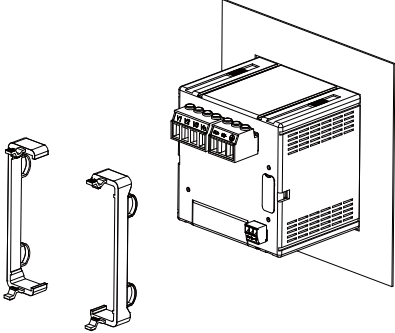
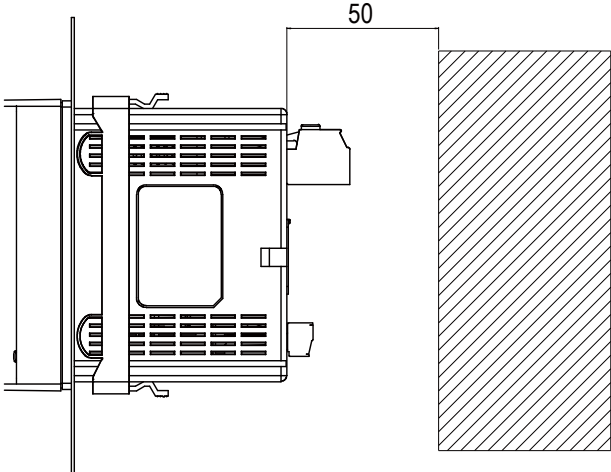
<p>Step 1: Open the square hole on the metal plate and then install the power meter.</p>	<p>Step 2: Install the fixing mount into the sliding slot and then push the meter in to touch the metal plate.</p>
	
<p>Step 3: During the installation, reserve a 50 mm-wide space behind the power meter for dissipating heat</p>	
 <p>Unit: mm</p>	

Dimensions of Panel Hole :

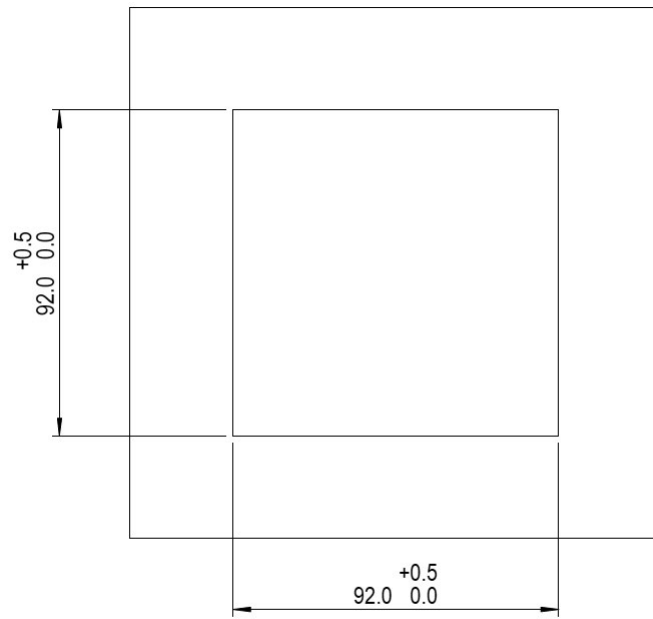

Panel Hole
Thickness : 0.8~4.0mm

Unit: mm (inches)

4.2 Basic Checks

Items Checked	Contents of Checks
General Check	<ul style="list-style-type: none"> ■ Regularly check for losing of the fixing mount at the location where the power meter and device are connected. ■ Guard against entrance of foreign objects, such as oil, water, or metal powder at the heat dissipating holes. Guard against entrance of drill cut powders into the power meter. ■ Should the power meter be installed at a place present with harmful gas or dust, guard against entrance of those matters into the meter.
Pre-operation Check (not supplied with control power)	<ul style="list-style-type: none"> ■ Insulate the connecting spot of the wiring terminals. ■ Communications wiring should be done properly, or abnormal operations might result. ■ Check for presence of conducive and flammable objects, such as screws or metal pieces, in the power meter. ■ Should electronic devices used near the power meter experience electromagnetic interference, tune with instruments to reduce electromagnetic interference. ■ Check for correct voltage level for the power supplied to the power meter.
Pre-running Check (supplied with control power)	<ul style="list-style-type: none"> ■ Check whether power indicator light is lit. ■ Check whether communication between every device is normal. ■ If there is any abnormal response from the power meter, contact your distributor or our customer service center.

Wiring Diagrams

5.1 Wiring on the Back

This chapter illustrates how the wiring on the back is done.

Note:

- To avoid electric shock, do not alter wiring when the power is on.
- As there is no power switch on the power meter, be sure to install a breaker switch on the power cord for the meter.

Recommended wiring materials are shown below:

Connecting Terminals	Wire Diameters	Screw Turning Torque
Functional Power	AWG 10~24	7.14 kgf-cm (0.7 N*m)
Measured Voltage	AWG 10~26	7.14 kgf-cm (0.7 N*m)
Measured Current	AWG 14~22	8.0 kgf-cm (0.79 N*m)
RS-485	AWG 14~28	2.04 kgf-cm (0.2 N*m)

RTwisted pair cables must be used in cabling for RS485 communication. When connecting multiple devices in series, the wiring method is displayed in the diagram below.

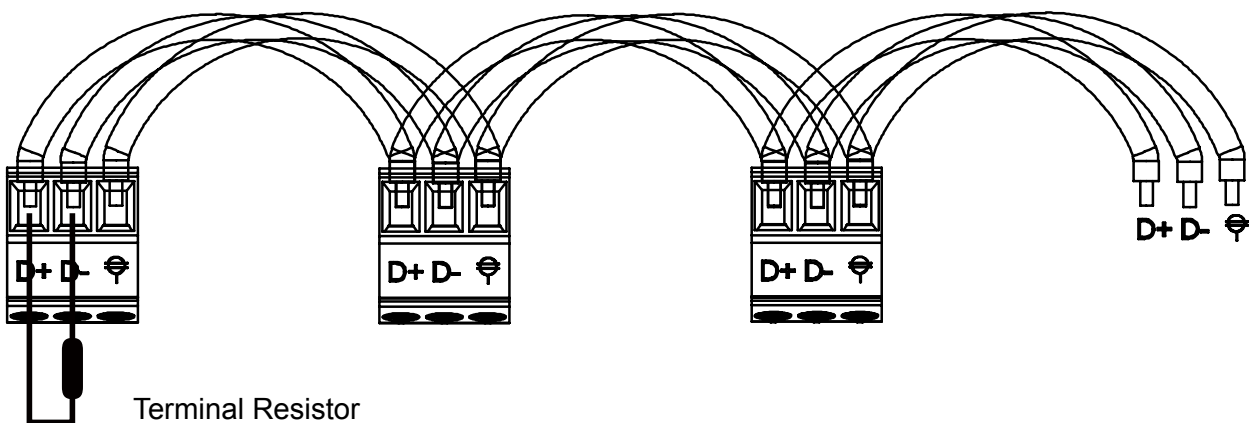

The D+ communication terminal for all devices should be connected on the same twisted pair cable. The D- terminals should be connected on the other twisted pair cable. The insulation net is grounded. The device on the end terminal needs to have terminal resistor installed on it.

5.2 Descriptions of Wiring

This chapter illustrates how wiring is done for this panel.

- Measured Voltage:

When measured voltage is higher than the rated specification (refer to Electrical Specification) for the device, use of an external potential transformer should be considered.

- Measured Current:

When measured current is higher than the rated specification (refer to Electrical Specification) for the device, use of an external current transformer should be considered.

- Supported Methods of Wiring:

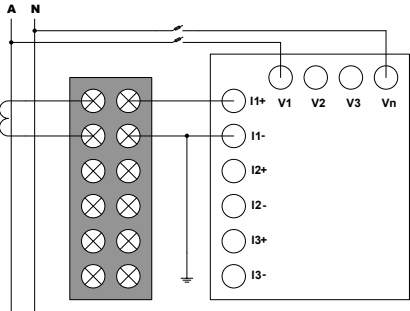
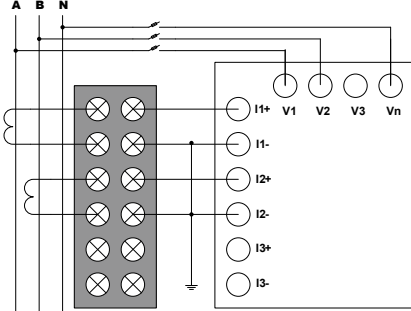
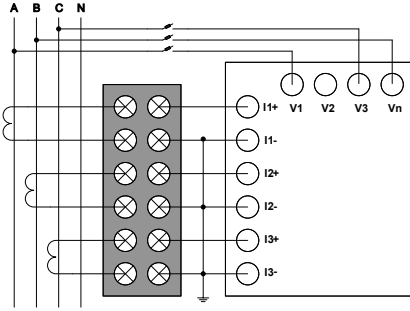
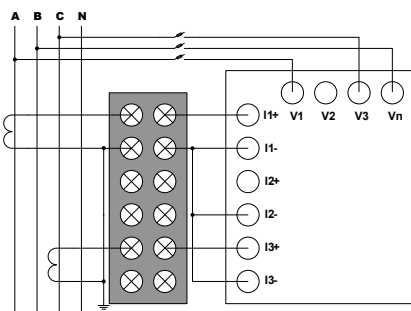
	
<p>Diagram 5-1: One-phase two-wire, 1 CT</p>	<p>Diagram 5-2: One-phase three-wire, 2 CT</p>
	
<p>Diagram 5-3: Three-phase three-wire, Δ Delta-connection, 3 CT, No PT</p>	<p>Diagram 5-4: Three-phase three-wire, Δ Delta-connection, 2 CT, No PT</p>

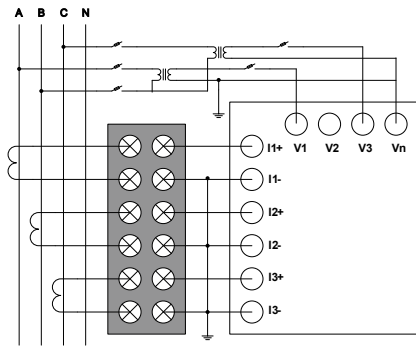

Diagram 5-5: Three-phase three-wire,
 Δ Delta-connection, 3 CT, 2 PT

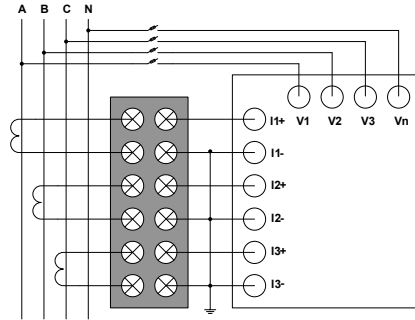

Diagram 5-6: Three-phase four-wire,
 Y-connection, 3 CT, No PT

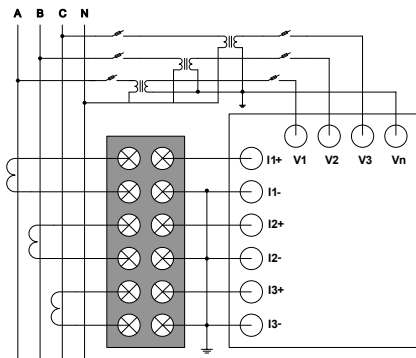

Diagram 5-7: Three-phase four-wire,
 Y-connection, 3 CT, 3 PT

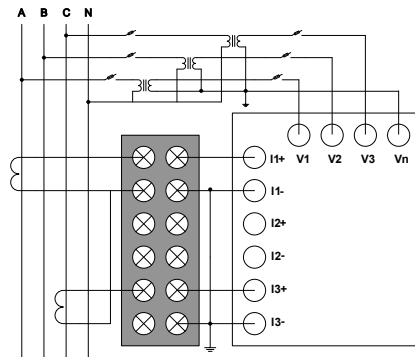

Diagram 5-8: Three-phase four-wire,
 Y-connection, 2 CT, 3 PT

■ The following symbols are used in the diagram:

Symbol					
Description	Grounding	Current transformer	Terminal resistor	Potential or voltage transformer	Fuse

Panel Display and Settings

6.1 Panel Display

6.1.1 Area of Display

DPM-C530A uses LCD display that exhibits four pieces of measurement information on each page. Diagram below is an illustration of the display panel:

Descriptions:

A	Title
B	Area of display
C	PULSE light
D	FAULT light
E	MENU key
F	UP key
G	DOWN key
H	ENTER key

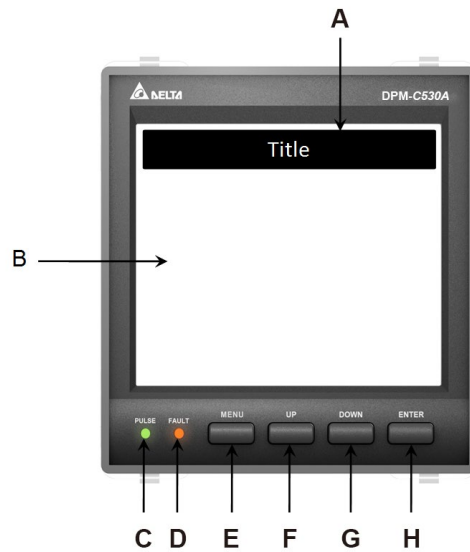

6.1.3 Descriptions of the Keys

Name of Key	General Mode	Configuration Mode
MENU key	Enter into Menu or return to previous page	Return without saving current settings
UP key	Move up to select an item or page	Increase numbers
DOWN key	Move down to select an item or page	Decrease numbers
ENTER key	Enter into the selected item	Enter into the setting and move to the next location of setting

6.1.3 Menu Tree

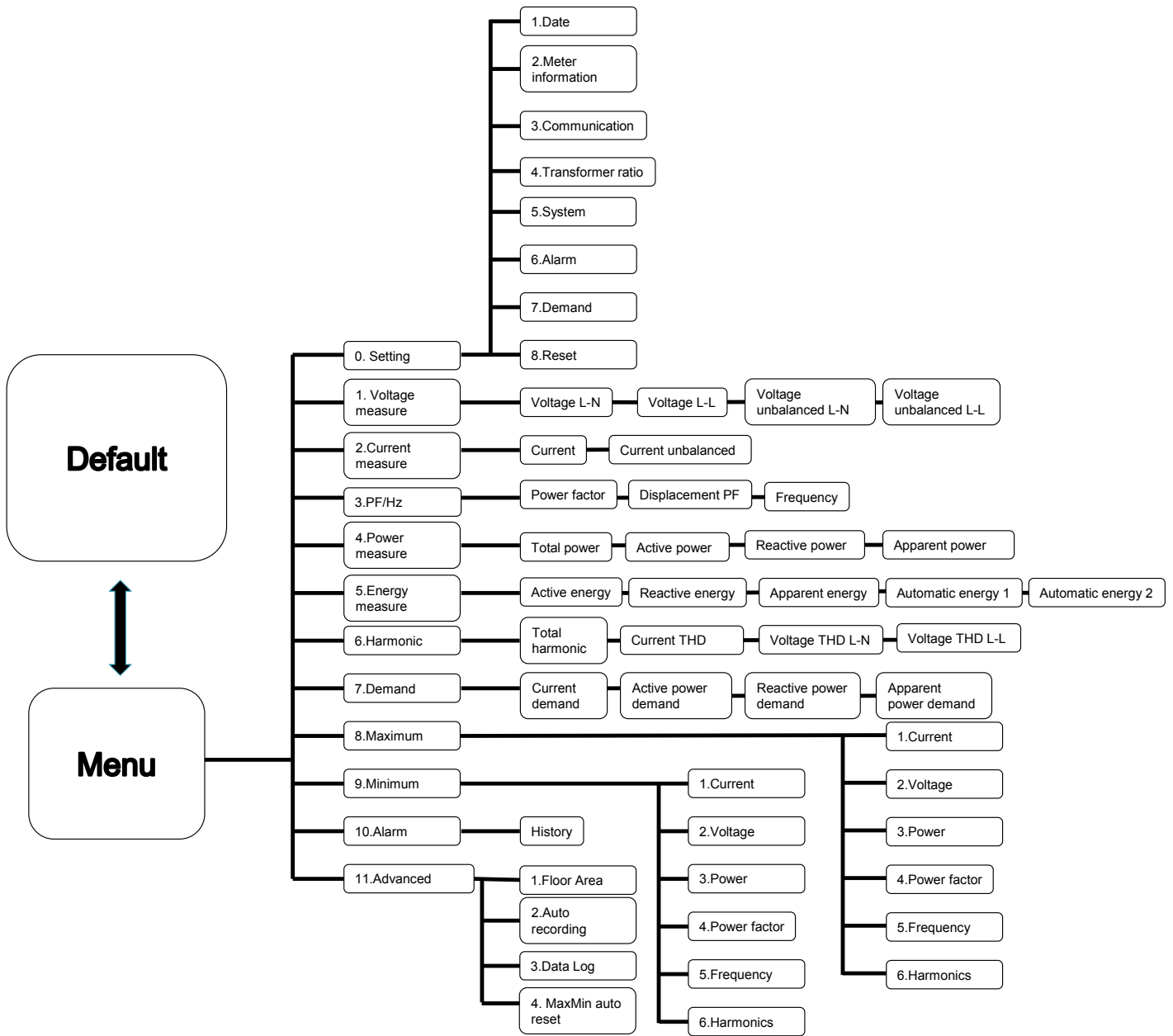

6.2 General Operations

6.2.1 Reading Measured Data

- **Voltage Measurement:**
Parameter of voltage measured by the power meter, including voltage L-N, voltage L-N, voltage L-N unbalance, voltage L-L unbalance, etc.
- **Current Measurement:** Parameter of currents measured by the meter, including current, current unbalance, etc.
- **Power Factor, Frequency (PF, Hz):**
Power factor and parameter of frequency measured by the meter, including power factor, displacement power factor, frequency, etc.
- **Power Measurement:**
Parameter of power measured by the meter, including active, reactive, and apparent power per phase and total.
- **Energy Measurement:**
Parameter of electrical energy by the meter, including active, reactive, and apparent electrical energy as delivered and received.
- **Harmonic:**
Parameter of harmonics measured by the meter, including total harmonic distortion for voltage and current per phase and total.
- **Demand:**
Parameter of demand measured by the meter, including demand for the last, present, predicted and peak current; active power; reactive power and apparent power.
- **Maximum:**
Maximum parameter measured by the meter, including maximum value of voltage, current, power factor, frequency, power, harmonic, and demand.
- **Minimum:**
Minimum parameter measured by the meter, including minimum value of voltage, current, power factor, frequency, power, harmonic, and demand.
- **Alarm:** Parameter of alarms for the meter.
 - (1) Press the Menu key until the menu appears.
 - (2) Select an item from 1~10 that you want to take a look at.
 - (3) Press the Up or Down key to switch between pages for every item of parameter.
 - (4) Press the Menu key to return to the menu page.

Example:

In item 1, Voltage Measurement, the default page shows voltage L-N. Press the Down key to switch to the page for voltage L-L. Press the Down key again to switch to the page to voltage L-N unbalance. Press the Down key again to switch to the page to voltage L-L unbalance. Press the Down key again to return to the voltage L-N page. Press the Up key to reverse the cycling order above.

6.3 Setup Operations

6.3.1 Time and Date Settings

- Time: Current time on the meter, including hour, minute, second.
- Date: Current date on the meter, including last two digits of the year, month, day, and day of week.
- Steps to set up are as follows:
 - (1) Press Menu key until the menu appears.
 - (2) Select 0. Setup and press Enter key to enter into the setup menu.
 - (3) Select 1. Date/Time and press the Enter key to enter into options.
 - (4) Select Time or Date and press the Enter key to start setting up.
 - (5) When the option is highlighted, start setting up by using the Up and Down keys to select the numbers needed for the time and date.
 - (6) Press the Enter key to finish setting up for a number and move on to set up for the next number.
 - (7) Repeat steps (5)~(6) until finishing setup for the last number and press the Enter key. When the highlight disappears, setup is complete. If there is a need to cancel the setup in the middle, press the Menu key to return without saving the numbers that were just set.
 - (8) After completing or cancelling the setup, press the Menu key again to return to the setup menu.

6.3.2 Communication Settings

- Address:
Range of address for the device is 1~254, with the broadcast address of 255 and factory default of 1.
- Protocol:
Mode of communication transmission, with a selection from RTU (factory default) and ASCII.
- Baud Rate:
Speed of communication transmission, with the factory default of 9600 kbps.
- Data Bit:
Length of packet data, with a selectable range of 7 and 8 bits; however, only 8 bits (factory default) is selectable under RTU mode.
- Parity:
Odd and even checking bit for communication, with a selection from None (factory default), Even, and Odd.
- Stop Bit:
Signal for completion of packet transmission, with a selection from 1 and 2 bit(s) (factory default: 1 bit).
- Steps to set up are as follows:
 - (1) Press Menu key until the menu appears.
 - (2) Select 0. Setup and press Enter key to enter into the setup menu.

- (3) Select 3. Communication and press the Enter key to enter into options.
- (4) Select Address and press the Enter key to start setting up for the address.
- (5) When the option is highlighted, start setting up by using the Up and Down keys to select the numbers needed.
- (6) Press the Enter key to finish setting up for a number and move on to set up for the next number.
- (7) Repeat steps (5)~(6) until finishing setup for the last number and press the Enter key. When the highlight disappears, setup is complete. If there is a need to cancel the setup in the middle, press the Menu key to return without saving the numbers that were just set.
- (8) Select Protocol and press the Enter key to start setting up for communication mode.
- (9) When the option is highlighted, start setting up by using the Up and Down keys to select the mode needed, such as RTU or ASCII.
- (10) Press the Enter key to complete. When the highlight disappears, setup is complete. If there is a need to cancel the setup in the middle, press the Menu key to return without saving the mode that was just selected.
- (11) Setup for Baud rate, data bit, parity, and stop bit all follow the steps mentioned above.
- (12) After completing or cancelling the setup, press the Menu key again to return to the setup menu.

6.3.3 Potential and Current Transformers Setting

- Primary-side current transformer (CT1): Ampere for the primary-side current transformer, with a selectable range of 1~9999 A (factory default: 1 A).
- Secondary-side current transformer (CT2): Ampere for the secondary-side current transformer, with a selection of 1 and 5 A (factory default: 1 A).
- Primary-side potential transformer (PT1): Voltage for the primary-side potential transformer, with a selectable range of 1~9999 V (factory default: 1 V).
- Secondary-side potential transformer (PT2): Voltage for the secondary-side potential transformer, with a selectable range of 1~9999 V (factory default: 1 V).
- Steps to set up are as follows:
 - (1) Press Menu key until the menu appears.
 - (2) Select 0. Setup and press Enter key to enter into the setup menu.
 - (3) Select 4. Transformer Ratio and press the Enter key to enter into options.
 - (4) Select CT1 and press the Enter key to start setting up for current transformer on the primary side.
 - (5) When the option is highlighted, start setting up by using the Up and Down keys to select the numbers needed.
 - (6) Press the Enter key to finish setting up for a number and move on to set up for the next number.
 - (7) Repeat steps (5)~(6) until finishing setup for the last number and press the Enter key. When the highlight disappears, setup is complete. If there is a need to cancel the setup in the middle, press the Menu key to return without saving the numbers that were just set.

(8) When the setup is finished, other parameters could be set. The steps start from step 5 mentioned above.

(9) After completing or cancelling the setup, press the Menu key again to return to the setup menu.

6.3.4 System Parameters Setting

■ **Language:**

Language displayed on the operating interface of the meter. Selectable languages are English (factory default), Traditional Chinese and Simplified Chinese.

■ **Backlight:**

Brightness of LCD backlight on the meter, with a selection of 100% (factory default), 50%, and 25%.

■ **Timeout:**

Time to maintain brightness of LCD backlight on the meter. With 100% selected, the backlight always remains bright. With 50% and 25% selected, power saving mode is on with a time set for the backlight (factory default is 30 seconds). Once the time is up, the backlight is turned off. Touching the keys turns on the backlight with a brightness based on the percentage selected.

■ **Power System:**

Selection of wiring method for the system, with a selection of one-phase two-wire, one-phase three-wire, three-phase three-wire, three-phase four-wire (factory default).

■ **Phase:**

For the phase A wire connected to phase C, reversing to phase C wire connected to phase A does not require re-wiring. Conversion is done by directly selecting this parameter. Selectable modes are ABC (factory default) and CBA.

■ **Number of CTs:**

Numbers of current transformers on the system. 0, 1, 2, 3 current transformers are selectable. The default setting of current transformers is 3.

■ **Number of PTs:**

Numbers of potential transformers on the system. 0, 2, 3 potential transformers are selectable. The default setting of potential transformers is 3.

■ **Steps to set up are as follows:**

(1) Press Menu key until the menu appears.

(2) Select 0. Setup and press Enter key to enter into the setup menu.

(3) Select 5. System and press the Enter key to enter into options.

(4) Select Language and press the Enter key to start setting up for language.

(5) When the option is highlighted, start setting up by using the Up and Down keys to select the mode needed.

(6) Press the Enter key to complete. When the highlight disappears, setup is complete. Press the Menu key to cancel the changes without saving.

- (7) Setup for backlight brightness, method of wiring, number of CT, number of PT and phase rotation all follow the steps mentioned above.
- (8) Select Timeout and press the Enter key to start setting up for timeout.
- (9) When the option is highlighted, start setting up by using the Up and Down keys to select the numbers needed.
- (10) Press the Enter key to finish setting up for a number and move on to set up for the next number.
- (11) Repeat steps (9)~(10) until finishing setup for the last number and press the Enter key. When the highlight disappears, setup is complete. Press the Menu key to cancel the changes without saving
- (12) After completing or cancelling the setup, press the Menu key again to return to the setup menu

6.3.5 Alarm Settings

- Alarm:
Whether this alarm is enabled or disabled (factory default).
- Pickup setpoint:
When the threshold set on the meter is exceeded, an alarm is generated triggered. The factory default is 0.
- Pickup Time Delay:
The alarm pickup occurs when a selected measurement value exceeds the alarm pickup magnitude for the pickup time delay. The factory default is 0.
- Dropout setpoint:
When the threshold set on the meter falls short, the alarm is cleared. The factory default is 0.
- Dropout Time Delay:
The alarm dropout occurs when selected measurement value is below the dropout magnitude for the dropout time delay. The factory default is 0.
- Steps to set up are as follows:
 - (1) Press Menu key until the menu appears.
 - (2) Select 0. Setup and press Enter key to enter into the setup menu.
 - (3) Select 6. Alarm and press the Enter key to enter into options.
 - (4) Select the setup item needed and press the Enter key to enter into the option.
 - (5) Select Alarm and press the Enter key to start setting up.
 - (6) When the option is highlighted, start setting up by using the Up and Down keys to select the mode needed.
 - (7) Press the Enter key to complete. When the highlight disappears, setup is complete. Press the Menu key to cancel the changes without saving
 - (8) Select Upper and press the Enter key to start setting up for time delay.
 - (9) When the option is highlighted, start setting up by using the Up and Down keys to select the numbers needed.

- (10) Press the Enter key to finish setting up for a number and move on to set up for the next number.
- (11) Repeat steps (9)~(10) until finishing setup for the last number and press the Enter key. When the highlight disappears, setup is complete. Press the Menu key to cancel the changes without saving
- (12) Select pickup time delay and press the Enter key to start setting up for pickup time delay
- (13) When the option is highlighted, start setting up by using the Up and Down keys to select the numbers needed.
- (14) Press the Enter key to finish setting up for a number and move on to set up for the next number.
- (15) Repeat steps (13)~(14) until finishing setup for the last number and press the Enter key. When the highlight disappears, setup is complete. Press the Menu key to cancel the changes without saving
- (16) For Dropout setpoint and dropout time delay, the steps to set up for them are the same as those from (8)~(15).
- (17) For other alarm options, the steps to set up for them are the same as those from (4)~(16).
- (18) After completing or cancelling the setup, press the Menu key twice to return to the setup menu.

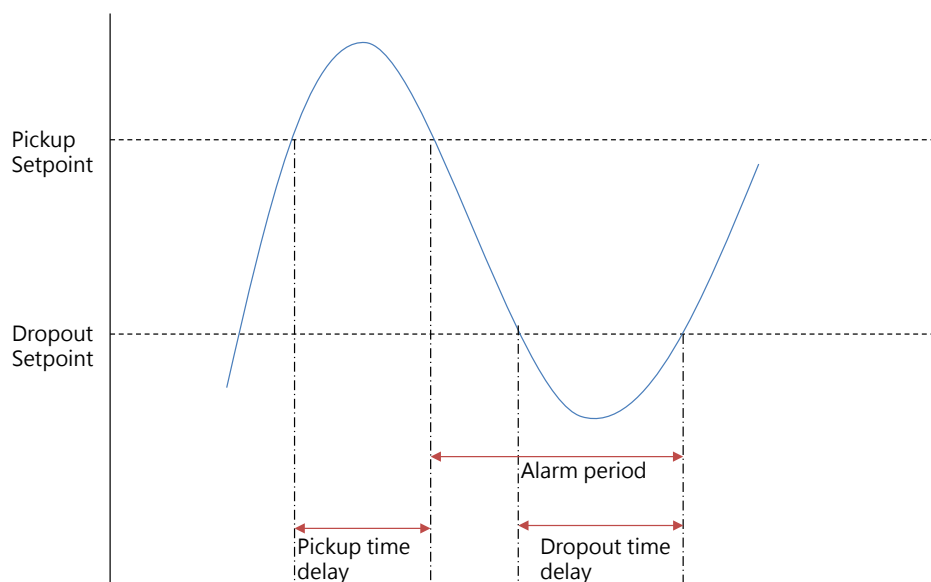

6.3.6 Demand Setting

- Method: Block interval demand method is supported for demand calculation.
- Interval: Time interval to calculate for the demand, with a selectable range of 1~99 min (factory default is 1 min).
- Steps to set up are as follows:
 - (1) Press Menu key until the menu appears.
 - (2) Select 0. Setup and press Enter key to enter into the setup menu.
 - (3) Select 7. Demand and press the Enter key to enter into options.

- (4) Select the setup item needed and press the Enter key to enter into the option.
- (5) Select Interval and press the Enter key to start setting up.
- (6) When the option is highlighted, start setting up by using the Up and Down keys to select the numbers needed.
- (7) Press the Enter key to finish setting up for a number and move on to set up for the next number.
- (8) Repeat steps (6)~(7) until finishing setup for the last number and press the Enter key. When the highlight disappears, setup is complete. Press the Menu key to cancel the changes without saving.
- (9) After completing or cancelling the setup, press the Menu key again to return to the setup menu.

6.3.7 Restore Settings

- Default: Restores settings on the meter to factory default.
- Energy: Resets to zero for the value of electrical energy accumulated on the meter and that calculated without a meter-checking personnel.
- Demand: Resets to zero for the current demand, demand power, and logged time and date.
- Alarm: Clears all alarm logs detected on the meter.
- MaxMin: Clears all records of maximum and minimum values logged on the meter.
- Data Log: Clears all historical data logs that are stored in the memory on the meter.
- Clear All: Restores all settings on the meter to factory default and clears all historical data logs
- Steps to set up are as follows:
 - (1) Press Menu key until the menu appears.
 - (2) Select 0. Setup and press Enter key to enter into the setup menu.
 - (3) Select 8. Reset and press the Enter key to enter into options.
 - (4) Select the setup item needed and press the Enter key to enter into the option.
 - (5) Press the Enter key to start setting up.
 - (6) When the option is highlighted, start setting up by using the Up and Down keys to select the mode needed.
 - (7) Press the Enter key to complete. When the highlight disappears, setup is complete. Press the Menu key to cancel the changes without saving.
 - (8) Repeat steps (6)~(7) until finishing setup for the last number and press the Enter key. When the highlight disappears, setup is complete. Press the Menu key to cancel the changes without saving.
 - (9) After completing or cancelling the setup, press the Menu key again to return to the setup menu.

6.4 Advance Setting

6.4.1 Auto metering

- Energy1:
Enable or disable auto metering Group 1. The Default setting is disabled.
- Auto Day1:
The selected date in every month for the meter to automatically calculate energy accumulation. The default is 0.
- Energy2:
Enable or disable auto metering Group 2. The Default is disabled.
- Auto Day2:
The selected date in every month for the meter to automatically calculate energy accumulation. The default is 0.
- Set up steps are as follows:
 - (1) Press Menu key until the menu page appears.
 - (2) Press UP or DOWN key to switch to the second page of the Menu. Select Item 11, and press Enter key.
 - (3) Press UP or DOWN key to select Item 2. and press Enter key.
 - (4) Select item “Energy1”, and press Enter key to set up.
 - (5) Start setting up by pressing UP and DOWN keys to select numbers when the option is highlighted.
 - (6) Press Enter key to finish setting up for a number, then move to set up other numbers.
 - (7) Repeat Step (5)~(6) until finishing the setup for the last number, and then press Enter key. When the highlight disappears, the setup is complete. Press the Menu key to cancel the changes without saving.
 - (8) Press UP or Down key to select “Energy1”, and press Enter key.
 - (9) Press UP and DOWN key to enable/disable this function when the option is highlighted.
 - (10) Press Enter key. When the highlight disappears, the setup is complete. Press the Menu key to cancel the changes without saving.
 - (11) For setup steps for auto metering for Group 2, please repeat Step 4 to Step 10.

6.4.2 Data Log Setting

- Interval:
Record parameter intervals. The first two numbers represents minute(s), the last two numbers represents second(s). The minimum interval is 0 minute 5 seconds; the maximum is 60 minutes. If 0 minute 0 second is set for the Interval, it means the function is disabled. The default is 0 minute 0 second.

■ Set up steps are as follows:

- (1) Configure MODBUS address 0x55B to 0x56B with code 1 to 17 through RS-485 communication. Code 1 ~ 17 represent 17 types of meter values that can be logged.
- (2) Data log only record date and time if Step1 is not completed.
- (3) Press UP or Down key to switch to the second page. Select Item 11 and press Enter key.
- (4) Press UP or Down key to select Item 3 and press Enter key.
- (5) Select item "Interval", and press Enter key to start setting.
- (6) Start set up when the options are highlighted. Press UP and Down keys to select numbers.
- (7) Press Enter key to finish setting for a number, and move to the next number.
- (8) Repeat Steps (5)~(6) until finishing the setup for the last number, and then press Enter key. When the highlight disappears, the setup is complete. Press the Menu key to cancel the changes without saving.

Example:

If it is necessary to record the values of Voltage L-N and Current, write number 1 (the code of Voltage L-N) into the MODBUS address 0x55B with function code 0x06 (single write) or 0x10 (multi write) first, and write number 2 (the code of Current) into the MODBUS address 0x55C with function code 0x06 (single write) or 0x10 (multi write). Other codes and MODBUS addresses please refer to Table 7.1.

※Notice:

- (1) Before setting up "Interval", make sure the codes of recording parameters are set already, or only date and time are recorded. "Interval" can be set through a user interface (setup steps as above), or MODBUS Communication (the address is 0x501).
- (2) The numbers of parameters are chosen by a different "Interval". The detailed spec is as shown below:

Interval	0 min, 0 sec ~ 0 min, 59 sec	1 min, 0 sec ~ 4 min, 59 sec	5 min, 0 sec ~ 60 min, 0 sec
Item Spec			
Maximum Number Of Parameters	6	17	17
Maximum Recording Days	7	31	62

6.4.3 Maximum and Minimum Interval Setting

■ Interval:

Restart to calculate and update the maximum and minimum values at the end of interval. Interval can be set by date, month, year and disable. When disable (default) is set, the maximum and minimum values are calculated since meter is power-on.

■ Set up steps are as follows:

- (1) Press Menu key until the menu appears.
- (2) Press UP or Down key to page 2, select Item 11, and press Enter key.
- (3) Press UP or Down key to select Item 4, and press Enter.
- (4) Select the desired interval and press Enter key.
- (5) Start to set up when the options are highlighted. Press UP and Down keys to select modes.
- (6) Press Enter key. When the highlight disappears, the setup completes. Press the Menu key to cancel the changes without saving.

6.4.4 Parameter Grouping

■ Parameter grouping:

block of MODBUS address mirrored from a standard selected MODBUS address that allows meter value, MODBUS address 0x100~0x1E7, can be gathered with single MODBUS block read. Default value is 0xFFFF.

■ Set up steps are as follows:

- (1) Configure MODBUS address 0x50c~0x551 with the selected MODBUS address of meter value by MODBUS function code 0x06 or 0x10.
- (2) Read MODBUS address 0x600~0x645 for selected meter values with MODBUS function code 0x3 after Step 1 completes.

Example:

1. If want to mirror the voltage L-N and current value from standard MODBUS address 0x100~0x101 and 0x126~0x127 to a continuous block MODBUS address which can be gathered with single MODBUS block read command. Write 0x100 and 0x101 (the MODBUS address of voltage L-N) into MODBUS address 0x50C and 0x50D with function code 0x06 (single write) or 0x10 (multi write). Write 0x126 and 0x127(the MODBUS address of current) into MODBUS address 0x50E and 0x50F with function code 0x06 (single write) or 0x10 (multi write). Other MODBUS addresses are shown in the 7.1 Address Table.
2. After step1 is finished, voltage L-N and current value can be gathered with a single MODBUS block read of address 0x50C~0x50F through MODBUS function code 0x03. Voltage L-N and current value are in IEEE754 format. Other MODBUS address data types are shown in 7.1 Address Table.

6.5 Power Analysis Values

6.5.1 Total Harmonic Distortion (THD)

Total harmonic distortion (THD) is a measure of the total distortion present in a waveform and is the ratio of harmonic content to the fundamental. THD is calculated for both voltage and current. The equations for calculating THD are shown below.

$$\text{THD current } THD_U = \frac{1}{|U_{fund}|} \sqrt{\sum_{n=2}^{31} |U_{n.Harm}|^2}$$

$$\text{THD voltage } THD_I = \frac{1}{|I_{fund}|} \sqrt{\sum_{n=2}^{31} |I_{n.Harm}|^2}$$

6.5.2 Demand Calculation Method

The power meter provided measurement values for current demand, active power demand, reactive power demand and apparent power demand. Last, present, predicted and peak demand values are calculated from above measured values. Fixed block interval demand methods are supported. Select an interval from 1 to 60 minutes, the present, predicted and peak demand values are updated every second, the last demand value is updated at the end of the interval.

Last: The power meter calculates demand for the last complete interval.

Present: The power meter calculates demand for the present incomplete interval.

Predicted: The power meter calculates predicted demand for the present interval.

Peak: The power meter maintains a running maximum demand for the present interval.

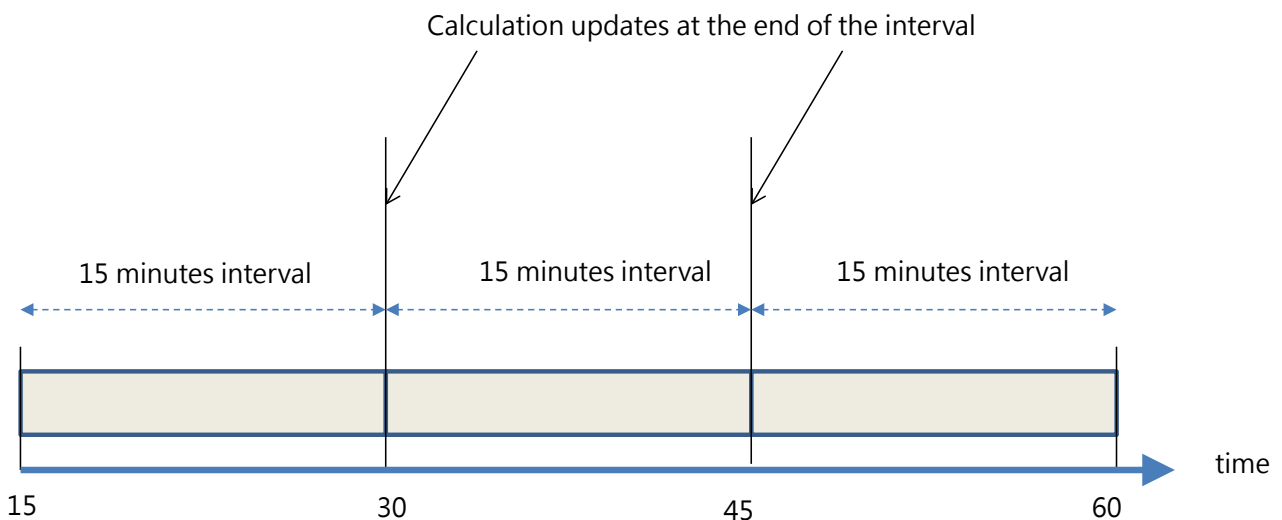

Parameters and Functions

7.1 Overview of Parameters

MODBUS Address		Item Communicated	Range	Data Type	Unit	Data Size (Byte)	Read (R) / Write (W)
Hex	Modicom Format						
0. System Parameter: 0001 ~ 00FF							
1	40002	Present date	year: 00~99 month: 1~12	byte	year, month	2	R / W
2	40003		day: 1~31 week: Sun.~Sat.	byte	day, week	2	R / W
3	40004	Present time	hour: 00~23 minute: 00~59	byte	hour and minute	2	R / W
4	40005		second: 00~59	word	second	2	R / W
5	40006	Meter constant	3200	uint	P/kWh	2	R
6	40007	Meter model	0: None 1: DPM-C530	word		2	R
7	40008	Total time on power	A87day: 0~65535	uint	day	2	R
8	40009		hour: 00~23 minute: 00~59	byte	hour and minute	2	R
9	40010	Firmware version	0.0000 ~ 9.9999	uint		2	R
A	40011	Data/Time of Last firmware download	year: 00~99 month: 1~12	byte	year, month	2	R
B	40012		day: 1~31	word	day	2	R
C	40013	Phase rotation	0: ABC 1: CBA	word		2	R / W
D	40014	Power system configuration	0: 3φ4W 1: 3φ3W 2: 1φ2W 3: 1φ3W	word		2	R / W
E	40015	CT primary(A)	1 ~ 9999	uint	A	2	R / W
F	40016	CT secondary(A)	0: 1A 1: 5A 2: 2.5A	word	A	2	R / W
10	40017	PT primary	1 ~ 9999	uint	V	2	R / W
11	40018	PT secondary	1 ~ 9999	uint	V	2	R / W
12	40019	Quantity of transformer	0: 3CT3PT 1: 3CT2PT 2: 3CT0PT 3: 2CT3PT 4: 2CT2PT 5: 2CT0PT 6: 1CT3PT 7: 1CT2PT 8: 1CT0PT	word		2	R / W
13	40020	Language	0: English 1: Traditional Chinese 2: Simplify Chinese	word		2	R / W
14	40021	Power-saving mode(second)	0~99	word	sec	2	R / W
15	40022	Screen brightness	0: 100% 1: 50% 2: 25%	word		2	R / W
16	40023	Baud rate	0: 9600 1: 19200 2: 38400	word	bps	2	R / W

17	40024	Communication mode	0: ASCII 1: RTU	word		2	R / W		
18	40025	Data bit	0: 8 1: 7	word	bit	2	R / W		
19	40026	Parity	0: None 1: Even 2: Odd	word		2	R / W		
1A	40027	Stop bit	0: 1 1: 2	word	bit	2	R / W		
1B	40028	MODBUS address	0 ~ 255	word		2	R / W		
1C	40029	Meter reset	0: None	word					
			1: Reset factory default						
			2: Reset value of energy						
			3: Reset value of demand						
			4: Clear alarm logs and times					2	W
			5: Reset maximum and minimum values						
			6: Clear data logs						
7: Clear all values									
1D	40030	Demand method	0: block	word		2	R		
1E	40031	Demand interval(min)	0 ~ 60	word	minute	2	R / W		
Alarm - Over Current									
1F	40032	Alarm Enable	0: Disable 1: Enable	word		2	R / W		
20	40033	Pickup setpoint (current exceeding this value, alarm triggered)	0.000 ~ 99999.999	Float	A	4	R / W		
21	40034								
22	40035	Pickup time delay	0~99	word	s	2	R / W		
23	40036	Dropout setpoint (current lower than this value, alarm cleared)	0.000 ~ 99999.999	Float	A	4	R / W		
24	40037								
25	40038	Dropout time delay	0~99	word	s	2	R / W		
Alarm - Under Current									
26	40039	Alarm Enable	0: Disable 1: Enable	word		2	R / W		
27	40040	Pickup setpoint (current lower than this value, alarm triggered)	0.000 ~ 99999.999	Float	A	4	R / W		
28	40041								
29	40042	Pickup time delay	0~99	word	s	2	R / W		
2A	40043	Dropout setpoint (current exceeding this value, alarm cleared)	0.000 ~ 99999.999	Float	A	4	R / W		
2B	40044								
2C	40045	Dropout time delay	0~99	word	s	2	R / W		
Alarm - Over Neutral Current									
2D	40046	Alarm Enable	0: Disable 1: Enable	word		2	R / W		
2E	40047	Pickup setpoint (current exceeding this value, alarm triggered)	0.000 ~ 99999.999	Float	A	4	R / W		
2F	40048								

30	40049	Pickup time delay	0~99	word	s	2	R / W
31	40050	Dropout setpoint (current lower than this value, alarm cleared)	0.000 ~ 99999.999	Float	A	4	R / W
32	40051						
33	40052	Dropout time delay	0~99	word	s	2	R / W
Alarm - Over Voltage L-L							
34	40053	Alarm Enable	0: Disable 1: Enable	word		2	R / W
35	40054	Pickup setpoint (voltage exceeding this value, alarm triggered)	0.000 ~ 99999.999	Float	V	4	R / W
36	40055						
37	40056	Pickup time delay	0~99	word	s	2	R / W
38	40057	Dropout setpoint (voltage lower than this value, alarm cleared)	0.000 ~ 99999.999	Float	V	4	R / W
39	40058						
3A	40059	Dropout time delay	0~99	word	s	2	R / W
Alarm - Under Voltage L-L							
3B	40060	Alarm Enable	0: Disable 1: Enable	word		2	R / W
3C	40061	Pickup setpoint (voltage lower than this value, alarm triggered)	0.000 ~ 99999.999	Float	V	4	R / W
3D	40062						
3E	40063	Pickup time delay	0~99	word	s	2	R / W
3F	40064	Dropout setpoint (voltage exceeding this value, alarm cleared)	0.000 ~ 99999.999	Float	V	4	R / W
40	40065						
41	40066	Dropout time delay	0~99	word	s	2	R / W
Alarm - Over Voltage L-N							
42	40067	Alarm Enable	0: Disable 1: Enable	word		2	R / W
43	40068	Pickup setpoint (voltage exceeding this value, alarm triggered)	0.000 ~ 99999.999	Float	V	4	R / W
44	40069						
45	40070	Pickup time delay	0~99	word	s	2	R / W
46	40071	Dropout setpoint (voltage lower than this value, alarm cleared)	0.000 ~ 99999.999	Float	V	4	R / W
47	40072						
48	40073	Dropout time delay	0~99	word	s	2	R / W
Alarm - Under Voltage L-N							
49	40074	Alarm Enable	0: Disable 1: Enable	word		2	R / W
4A	40075	Pickup setpoint (voltage lower than this value, alarm triggered)	0.000 ~ 99999.999	Float	V	4	R / W
4B	40076						
4C	40077	Pickup time delay	0~99	word	s	2	R / W
4D	40078	Dropout setpoint (voltage exceeding this value, alarm cleared)	0.000 ~ 99999.999	Float	V	4	R / W
4E	40079						
4F	40080	Dropout time delay	0~99	word	s	2	R / W

Alarm - Over Voltage Unbalance							
50	40081	Alarm Enable	0: Disable 1: Enable	word		2	R / W
51	40082	Pickup setpoint (voltage unbalance exceeding this value, alarm triggered)	0.00 ~ 99.99	Float	%	4	R / W
52	40083						
53	40084	Pickup time delay	0~99	word	s	2	R / W
54	40085	Dropout setpoint (voltage lower than this value, alarm cleared)	0.00 ~ 99.99	Float	%	4	R / W
55	40086						
56	40087	Dropout time delay	0~99	word	s	2	R / W
Alarm - Over Current Unbalance							
57	40088	Alarm Enable	0: Disable 1: Enable	word		2	R / W
58	40089	Pickup setpoint (current unbalance exceeding this value, alarm triggered)	0.00 ~ 99.99	Float	%	4	R / W
59	40090						
5A	40091	Pickup time delay	0~99	word	s	2	R / W
5B	40092	Dropout setpoint (current lower than this value, alarm cleared)	0.00 ~ 99.99	Float	%	4	R / W
5C	40093						
5D	40094	Dropout time delay	0~99	word	s	2	R / W
Alarm - Over Active Power							
5E	40095	Alarm Enable	0: Disable 1: Enable	word		2	R / W
5F	40096	Pickup setpoint (active power exceeding this value, alarm triggered)	0.000 ~ 99999.999	Float	kW	4	R / W
60	40097						
61	40098	Pickup time delay	0~99	word	s	2	R / W
62	40099	Dropout setpoint (active power lower than this value, alarm cleared)	0.000 ~ 99999.999	Float	kW	4	R / W
63	40100						
64	40101	Dropout time delay	0~99	word	s	2	R / W
Over Reactive Power							
65	40102	Alarm Enable	0: Disable 1: Enable	word		2	R / W
66	40103	Pickup setpoint (reactive power exceeding this value, alarm triggered)	0.000 ~ 99999.999	Float	kVAR	4	R / W
67	40104						
68	40105	Pickup time delay	0~99	word	s	2	R / W
69	40106	Dropout setpoint (reactive power lower than this value, alarm cleared)	0.000 ~ 99999.999	Float	kVAR	4	R / W
6A	40107						
6B	40108	Dropout time delay	0~99	word	s	2	R / W
Alarm - Over Apparent Power							
6C	40109	Alarm Enable	0: Disable 1: Enable	word		2	R / W
6D	40110	Pickup setpoint (apparent power exceeding this value, alarm triggered)	0.000 ~ 99999.999	Float	kVA	4	R / W
6E	40111						

6F	40112	Pickup time delay	0~99	word	s	2	R / W
70	40113	Dropout setpoint (apparent power lower than this value, alarm cleared)	0.000 ~ 99999.999	Float	kVA	4	R / W
71	40114						
72	40115	Dropout time delay	0~99	word	s	2	R / W
Alarm - Lead PF							
73	40116	Alarm Enable	0: Disable 1: Enable	word		2	R / W
74	40117	Pickup setpoint (power factory lower than this value, alarm triggered)	0.00000 ~ 1.00000	Float		4	R / W
75	40118						
76	40119	Pickup time delay	0~99	word	s	2	R / W
77	40120	Dropout setpoint (power factory exceeding this value, alarm cleared)	0.00000 ~ 1.00000	Float		4	R / W
78	40121						
79	40122	Dropout time delay	0~99	word	s	2	R / W
Alarm - Lag PF							
7A	40123	Alarm Enable	0: Disable 1: Enable	word		2	R / W
7B	40124	Pickup setpoint (power factory lower than this value, alarm triggered)	0.00000 ~ 1.00000	Float		4	R / W
7C	40125						
7D	40126	Pickup time delay	0~99	word	s	2	R / W
7E	40127	Dropout setpoint (power factory exceeding this value, alarm cleared)	0.00000 ~ 1.00000	Float		4	R / W
7F	40128						
80	40129	Dropout time delay	0~99	word	s	2	R / W
Alarm - Lead Displacement PF							
81	40130	Alarm Enable	0: Disable 1: Enable	word		2	R / W
82	40131	Pickup setpoint (displacement power factory lower than this value, alarm triggered)	0.00000 ~ 1.00000	Float		4	R / W
83	40132						
84	40133	Pickup time delay	0~99	word	s	2	R / W
85	40134	Dropout setpoint (displacement power factory exceeding this value, alarm cleared)	0.00000 ~ 1.00000	Float		4	R / W
86	40135						
87	40136	Dropout time delay	0~99	word	s	2	R / W
Alarm - Lag Displacement PF							
88	40137	Alarm Enable	0: Disable 1: Enable	word		2	R / W
89	40138	Pickup setpoint (displacement power factory lower than this value, alarm triggered)	0.00000 ~ 1.00000	Float		4	R / W
8A	40139						
8B	40140	Pickup time delay	0~99	word	s	2	R / W
8C	40141	Dropout setpoint (displacement power factory exceeding this value, alarm cleared)	0.00000 ~ 1.00000	Float		4	R / W
8D	40142						
8E	40143	Dropout time delay	0~99	word	s	2	R / W

Alarm - Over Current Demand							
8F	40144	Alarm Enable	0: Disable 1: Enable	word		2	R / W
90	40145	Pickup setpoint (current demand exceeding this value, alarm triggered)	0.000 ~ 99999.999	Float	A	4	R / W
91	40146						
92	40147	Pickup time delay	0~99	word	s	2	R / W
93	40148	Dropout setpoint (current demand lower than this value, alarm cleared)	0.000 ~ 99999.999	Float	A	4	R / W
94	40149						
95	40150	Dropout time delay	0~99	word	s	2	R / W
Alarm - Over Active Power Demand							
96	40151	Alarm Enable	0: Disable 1: Enable	word		2	R / W
97	40152	Pickup setpoint (active power demand exceeding this value, alarm triggered)	0.000 ~ 99999.999	Float	kW	4	R / W
98	40153						
99	40154	Pickup time delay	0~99	word	s	2	R / W
9A	40155	Dropout setpoint (active power demand lower than this value, alarm cleared)	0.000 ~ 99999.999	Float	kW	4	R / W
9B	40156						
9C	40157	Dropout time delay	0~99	word	s	2	R / W
Alarm - Over Reactive Power Demand							
9D	40158	Alarm Enable	0: Disable 1: Enable	word		2	R / W
9E	40159	Pickup setpoint (reactive power demand exceeding this value, alarm triggered)	0.000 ~ 99999.999	Float	kVAR	4	R / W
9F	40160						
A0	40161	Pickup time delay	0~99	word	s	2	R / W
A1	40162	Dropout setpoint (reactive power demand lower than this value, alarm cleared)	0.000 ~ 99999.999	Float	kVAR	4	R / W
A2	40163						
A3	40164	Dropout time delay	0~99	word	s	2	R / W
Alarm - Over Apparent Power Demand							
A4	40165	Alarm Enable	0: Disable 1: Enable	word		2	R / W
A5	40166	Pickup setpoint (apparent power demand exceeding this value, alarm triggered)	0.000 ~ 99999.999	Float	kVA	4	R / W
A6	40167						
A7	40168	Pickup time delay	0~99	word	s	2	R / W
A8	40169	Dropout setpoint (apparent power demand lower than this value, alarm cleared)	0.000 ~ 99999.999	Float	kVA	4	R / W
A9	40170						
AA	40171	Dropout time delay	0~99	word	s	2	R / W
Alarm - Over Frequency							
AB	40172	Alarm Enable	0: Disable 1: Enable	word		2	R / W

AC	40173	Pickup setpoint (frequency exceeding this value, alarm triggered)	0.0000 ~ 99.9999	Float	Hz	4	R / W
AD	40174						
AE	40175	Pickup time delay	0~99	word	s	2	R / W
AF	40176	Dropout setpoint (frequency lower than this value, alarm cleared)	0.0000 ~ 99.9999	Float	Hz	4	R / W
B0	40177						
B1	40178	Dropout time delay	0~99	word	s	2	R / W
Alarm - Under Frequency							
B2	40179	Alarm Enable	0: Disable 1: Enable	word		2	R / W
B3	40180	Pickup setpoint (frequency lower than this value, alarm triggered)	0.0000 ~ 99.9999	Float	Hz	4	R / W
B4	40181						
B5	40182	Pickup time delay	0~99	word	s	2	R / W
B6	40183	Dropout setpoint (frequency exceeding this value, alarm cleared)	0.0000 ~ 99.9999	Float	Hz	4	R / W
B7	40184						
B8	40185	Dropout time delay	0~99	word	s	2	R / W
Alarm - Over Voltage THD							
B9	40186	Alarm Enable	0: Disable 1: Enable	word		2	R / W
BA	40187	Pickup setpoint (voltage THD exceeding this value, alarm triggered)	0.000 ~ 999.999	Float	%	4	R / W
BB	40188						
BC	40189	Pickup time delay	0~99	word	s	2	R / W
BD	40190	Dropout setpoint (voltage THD lower than this value, alarm cleared)	0.000 ~ 999.999	Float	%	4	R / W
BE	40191						
BF	40192	Dropout time delay	0~99	word	s	2	R / W
Alarm - Over Current THD							
C0	40193	Alarm Enable	0: Disable 1: Enable	word		2	R / W
C1	40194	Pickup setpoint (current THD exceeding this value, alarm triggered)	0.000 ~ 999.999	Float	%	4	R / W
C2	40195						
C3	40196	Pickup time delay	0~99	word	s	2	R / W
C4	40197	Dropout setpoint (current THD lower than this value, alarm cleared)	0.000 ~ 999.999	Float	%	4	R / W
C5	40198						
C6	40199	Dropout time delay	0~99	word	s	2	R / W
Alarm - Phase Loss							
C7	40200	Alarm Enable	0: Disable 1: Enable	word		2	R / W
Alarm - Over DUI							
CE	40207	Alarm Enable	0: Disable 1: Enable	word		2	R / W
CF	40208	Pickup setpoint (DUI exceeding this value, alarm triggered)	0.000 ~ 99999.999	Float	kW / m ²	4	R / W
D0	40209						

D1	40210	Pickup time delay	0~99	word	s	2	R / W
D2	40211	Dropout setpoint (DUI lower than this value, alarm cleared)	0.000 ~ 99999.999	Float	kW / m2	4	R / W
D3	40212						
D4	40213	Dropout time delay	0~99	word	s	2	R / W
Alarm - Over EUI							
D5	40214	Alarm Enable	0: Disable 1: Enable	word		2	R / W
D6	40215	Pickup setpoint (EUI exceeding this value, alarm triggered)	0.000 ~ 99999.999	Float	kWh / m2	4	R / W
D7	40216						
D8	40217	Pickup time delay	0~99	word	s	2	R / W
D9	40218	Dropout setpoint (EUI lower than this value, alarm cleared)	0.000 ~ 99999.999	Float	kWh / m2	4	R / W
DA	40219						
DB	40220	Dropout time delay	0~99	word	s	2	R / W
Alarm - Meter Reset							
DC	40221	Alarm Enable	0: Disable 1: Enable	word		2	R / W
Alarm - Phase Rotation							
DD	40222	Alarm Enable	0: Disable 1: Enable	word		2	R / W
1. Meter Parameters: 0100 ~ 01FF							
100	40257	Voltage A-N	0.000 ~ 99999.999	Float	V	4	R
101	40258						
102	40259	Voltage B-N	0.000 ~ 99999.999	Float	V	4	R
103	40260						
104	40261	Voltage C-N	0.000 ~ 99999.999	Float	V	4	R
105	40262						
106	40263	Voltage L-N Avg	0.000 ~ 99999.999	Float	V	4	R
107	40264						
108	40265	Voltage A-B	0.000 ~ 99999.999	Float	V	4	R
109	40266						
10A	40267	Voltage B-C	0.000 ~ 99999.999	Float	V	4	R
10B	40268						
10C	40269	Voltage C-A	0.000 ~ 99999.999	Float	V	4	R
10D	40270						
10E	40271	Voltage L-L Avg	0.000 ~ 99999.999	Float	V	4	R
10F	40272						
110	40273	Voltage unbalance A-N	0.00 ~ 99.99	Float	%	4	R
111	40274						

112	40275	Voltage unbalance B-N	0.00 ~ 99.99	Float	%	4	R
113	40276						
114	40277	Voltage unbalance C-N	0.00 ~ 99.99	Float	%	4	R
115	40278						
116	40279	Voltage unbalance L-N Avg	0.00 ~ 99.99	Float	%	4	R
117	40280						
118	40281	Voltage unbalance A-B	0.00 ~ 99.99	Float	%	4	R
119	40282						
11A	40283	Voltage unbalance B-C	0.00 ~ 99.99	Float	%	4	R
11B	40284						
11C	40285	Voltage unbalance C-A	0.00 ~ 99.99	Float	%	4	R
11D	40286						
11E	40287	Voltage unbalance L-L Avg	0.00 ~ 99.99	Float	%	4	R
11F	40288						
120	40289	Current A	0.000 ~ 99999.999	Float	A	4	R
121	40290						
122	40291	Current B	0.000 ~ 99999.999	Float	A	4	R
123	40292						
124	40293	Current C	0.000 ~ 99999.999	Float	A	4	R
125	40294						
126	40295	Current Avg	0.000 ~ 99999.999	Float	A	4	R
127	40296						
128	40297	Current N	0.000 ~ 99999.999	Float	A	4	R
129	40298						
12A	40299	Current unbalance A	0.00 ~ 99.99	Float	%	4	R
12B	40300						
12C	40301	Current unbalance B	0.00 ~ 99.99	Float	%	4	R
12D	40302						
12E	40303	Current unbalance C	0.00 ~ 99.99	Float	%	4	R
12F	40304						
130	40305	Current unbalance Avg	0.00 ~ 99.99	Float	%	4	R
131	40306						
132	40307	Power factor total (positive : lag negative : lead)	0.00000 ~ 1.00000	Float		4	R
133	40308						
134	40309	Power factor A (positive : lag negative : lead)	0.00000 ~ 1.00000	Float		4	R
135	40310						

136	40311	Power factor B	0.00000 ~ 1.00000 (positive : lag negative : lead)	Float		4	R
137	40312						
138	40313	Power factor C	0.00000 ~ 1.00000 (positive : lag negative : lead)	Float		4	R
139	40314						
13A	40315	Displacement power factor total	0.00000 ~ 1.00000 (positive : lag negative : lead)	Float		4	R
13B	40316						
13C	40317	Displacement power factor A	0.00000 ~ 1.00000 (positive : lag negative : lead)	Float		4	R
13D	40318						
13E	40319	Displacement power factor B	0.00000 ~ 1.00000 (positive : lag negative : lead)	Float		4	R
13F	40320						
140	40321	Displacement power factor C	0.00000 ~ 1.00000 (positive : lag negative : lead)	Float		4	R
141	40322						
142	40323	Frequency	0.0000 ~ 99.9999	Float	Hz	4	R
143	40324						
144	40325	Active power total	0.000 ~ 99999.999	Float	kW	4	R
145	40326						
146	40327	Active power A	0.000 ~ 99999.999	Float	kW	4	R
147	40328						
148	40329	Active power B	0.000 ~ 99999.999	Float	kW	4	R
149	40330						
14A	40331	Active power C	0.000 ~ 99999.999	Float	kW	4	R
14B	40332						
14C	40333	Reactive power total	0.000 ~ 99999.999	Float	kVAR	4	R
14D	40334						
14E	40335	Reactive power A	0.000 ~ 99999.999	Float	kVAR	4	R
14F	40336						
150	40337	Reactive power B	0.000 ~ 99999.999	Float	kVAR	4	R
151	40338						
152	40339	Reactive power C	0.000 ~ 99999.999	Float	kVAR	4	R
153	40340						
154	40341	Apparent power total	0.000 ~ 99999.999	Float	kVA	4	R
155	40342						
156	40343	Apparent power A	0.000 ~ 99999.999	Float	kVA	4	R
157	40344						
158	40345	Apparent power B	0.000 ~ 99999.999	Float	kVA	4	R
159	40346						

15A	40347	Apparent power C	0.000 ~ 99999.999	Float	kVA	4	R
15B	40348						
15C	40349	Active energy delivered	0x00000000 ~ 0xFFFFFFFF	uint	Wh	4	R
15D	40350						
15E	40351	Active energy received	0x00000000 ~ 0xFFFFFFFF	uint	Wh	4	R
15F	40352						
160	40353	Reactive energy delivered	0x00000000 ~ 0xFFFFFFFF	uint	VARh	4	R
161	40354						
162	40355	Reactive energy received	0x00000000 ~ 0xFFFFFFFF	uint	VARh	4	R
163	40356						
164	40357	Apparent energy delivered	0x00000000 ~ 0xFFFFFFFF	uint	VAh	4	R
165	40358						
166	40359	Apparent energy received	0x00000000 ~ 0xFFFFFFFF	uint	VAh	4	R
167	40360						
168	40361	Active energy delivered + received	0x00000000 ~ 0xFFFFFFFF	uint	Wh	4	R
169	40362						
16A	40363	Active energy delivered - received	0x80000001 ~ 0x7FFFFFFF (Negative for 2' s complement)	int	Wh	4	R
16B	40364						
16C	40365	Reactive energy delivered + received	0x00000000 ~ 0xFFFFFFFF	uint	VARh	4	R
16D	40366						
16E	40367	Reactive energy delivered - received	0x80000001 ~ 0x7FFFFFFF (Negative for 2' s complement)	int	VARh	4	R
16F	40368						
170	40369	Apparent energy delivered + received	0x00000000 ~ 0xFFFFFFFF	uint	VAh	4	R
171	40370						
172	40371	Apparent energy delivered - received	0x80000001 ~ 0x7FFFFFFF (Negative for 2' s complement)	int	VAh	4	R
173	40372						
174	40373	THD current A	0.000 ~ 999.999	Float	%	4	R
175	40374						
176	40375	THD current B	0.000 ~ 999.999	Float	%	4	R
177	40376						
178	40377	THD current C	0.000 ~ 999.999	Float	%	4	R
179	40378						
17A	40379	THD current N	0.000 ~ 999.999	Float	%	4	R
17B	40380						
17C	40381	THD voltage A-N	0.000 ~ 999.999	Float	%	4	R
17D	40382						

17E	40383	THD voltage B-N	0.000 ~ 999.999	Float	%	4	R
17F	40384						
180	40385	THD voltage C-N	0.000 ~ 999.999	Float	%	4	R
181	40386						
182	40387	THD voltage A-B	0.000 ~ 999.999	Float	%	4	R
183	40388						
184	40389	THD voltage B-C	0.000 ~ 999.999	Float	%	4	R
185	40390						
186	40391	THD voltage C-A	0.000 ~ 999.999	Float	%	4	R
187	40392						
188	40393	THD current - Avg	0.000 ~ 999.999	Float	%	4	R
189	40394						
18A	40395	THD voltage - Avg	0.000 ~ 999.999	Float	%	4	R
18B	40396						
18C	40397	Present demand – current avg	0.000 ~ 99999.999	Float	A	4	R
18D	40398						
18E	40399	Last demand – current avg	0.000 ~ 99999.999	Float	A	4	R
18F	40400						
190	40401	Predicted demand – current avg	0.000 ~ 99999.999	Float	A	4	R
191	40402						
192	40403	Peak demand – current avg	0.000 ~ 99999.999	Float	A	4	R
193	40404						
194	40405	Peak Demand date – current avg	year: 00~99 month: 1~12	byte	year, month	2	R
195	40406		day: 1~31	word	day	2	R
196	40407	Peak Demand time – current avg	hour: 00~23 minute: 00~59	byte	hour and minute	2	R
197	40408		second: 00~59	word	second	2	R
198	40409	Present demand – active power	0.000 ~ 99999.999	Float	kW	4	R
199	40410						
19A	40411	Last demand – active power	0.000 ~ 99999.999	Float	kW	4	R
19B	40412						
19C	40413	Predicted demand – active power	0.000 ~ 99999.999	Float	kW	4	R
19D	40414						
19E	40415	Peak demand – active power	0.000 ~ 99999.999	Float	kW	4	R
19F	40416						
1A0	40417	Peak demand date – active power	year: 00~99 month: 1~12	byte	year, month	2	R
1A1	40418		day: 1~31	word	day	2	R

1A2	40419	Peak demand time – active power	hour: 00~23 minute: 00~59	byte	hour and minute	2	R
1A3	40420		second: 00~59	word	second	2	R
1A4	40421	Present demand – reactive power	0.000 ~ 99999.999	Float	kVAR	4	R
1A5	40422						
1A6	40423	Last demand – reactive power	0.000 ~ 99999.999	Float	kVAR	4	R
1A7	40424						
1A8	40425	Predicted demand – reactive power	0.000 ~ 99999.999	Float	kVAR	4	R
1A9	40426						
1AA	40427	Peak demand – reactive power	0.000 ~ 99999.999	Float	kVAR	4	R
1AB	40428						
1AC	40429	Peak demand date – reactive power	year: 00~99 month: 1~12	byte	year, month	2	R
1AD	40430		day: 1~31	word	day	2	R
1AE	40431	Peak demand time – reactive power	hour: 00~23 minute: 00~59	byte	hour and minute	2	R
1AF	40432		second: 00~59	word	second	2	R
1B0	40433	Present demand – apparent power	0.000 ~ 99999.999	Float	kVA	4	R
1B1	40434						
1B2	40435	Last demand –apparent power	0.000 ~ 99999.999	Float	kVA	4	R
1B3	40436						
1B4	40437	Predicted demand –apparent power	0.000 ~ 99999.999	Float	kVA	4	R
1B5	40438						
1B6	40439	Peak demand –apparent power	0.000 ~ 99999.999	Float	kVA	4	R
1B7	40440						
1B8	40441	Peak demand date –apparent power	year: 00~99 month: 1~12	byte	year, month	2	R
1B9	40442		day: 1~31	word	day	2	R
1BA	40443	Peak demand time –apparent power	hour: 00~23 minute: 00~59	byte	hour and minute	2	R
1BB	40444		second: 00~59	word	second	2	R
1BC	40445	DUI	0.000 ~ 99999.999	Float	kW/m2	4	R
1BD	40446						
1BE	40447	EUI	0.000 ~ 4294967295.000	Float	kWh/m2	4	R
1BF	40448						
1C0	40449	Auto metering I – active energy delivered	0x00000000 ~ 0xFFFFFFFF	uint	Wh	4	R
1C1	40450						
1C2	40451	Auto metering I – active energy received	0x00000000 ~ 0xFFFFFFFF	uint	Wh	4	R
1C3	40452						
1C4	40453	Auto metering II – active energy delivered	0x00000000 ~ 0xFFFFFFFF	uint	Wh	4	R
1C5	40454						

1C6	40455	Auto meter reading II – active energy received	0x00000000 ~ 0xFFFFFFFF	uint	Wh	4	R
1C7	40456						
1C8	40457	Auto metering I – reactive energy delivered	0x00000000 ~ 0xFFFFFFFF	uint	VARh	4	R
1C9	40458						
1CA	40459	Auto metering I – reactive energy received	0x00000000 ~ 0xFFFFFFFF	uint	VARh	4	R
1CB	40460						
1CC	40461	Auto metering II – reactive energy delivered	0x00000000 ~ 0xFFFFFFFF	uint	VARh	4	R
1CD	40462						
1CE	40463	Auto metering II – reactive energy received	0x00000000 ~ 0xFFFFFFFF	uint	VARh	4	R
1CF	40464						
1D0	40465	Total fundamental active power	0.000 ~ 99999.999	Float	kW	4	R
1D1	40466						
1D2	40467	Fundamental active power A	0.000 ~ 99999.999	Float	kW	4	R
1D3	40468						
1D4	40469	Fundamental active power B	0.000 ~ 99999.999	Float	kW	4	R
1D5	40470						
1D6	40471	Fundamental active power C	0.000 ~ 99999.999	Float	kW	4	R
1D7	40472						
1D8	40473	Total fundamental reactive power	0.000 ~ 99999.999	Float	kVAR	4	R
1D9	40474						
1DA	40475	Fundamental reactive power A	0.000 ~ 99999.999	Float	kVAR	4	R
1DB	40476						
1DC	40477	Fundamental reactive power B	0.000 ~ 99999.999	Float	kVAR	4	R
1DD	40478						
1DE	40479	Fundamental reactive power C	0.000 ~ 99999.999	Float	kVAR	4	R
1DF	40480						
1E0	40481	Total fundamental apparent power	0.000 ~ 99999.999	Float	kVA	4	R
1E1	40482						
1E2	40483	Fundamental apparent power A	0.000 ~ 99999.999	Float	kVA	4	R
1E3	40484						
1E4	40485	Fundamental apparent power B	0.000 ~ 99999.999	Float	kVA	4	R
1E5	40486						
1E6	40487	Fundamental apparent power C	0.000 ~ 99999.999	Float	kVA	4	R
1E7	40488						

2. Maximum Values: 0200 ~ 02FF							
200	40513	Max voltage A-B	0.000 ~ 99999.999	Float	V	4	R
201	40514						
202	40515	Max voltage A-B date	year: 00~99 month: 1~12	byte	year, month	2	R
203	40516		day: 1~31	word	day	2	R
204	40517	Max voltage A-B time	hour: 00~23 minute: 00~59	byte	hour and minute	2	R
205	40518		second: 00~59	word	second	2	R
206	40519	Max voltage B-C	0.000 ~ 99999.999	Float	V	4	R
207	40520						
208	40521	Max voltage B-C date	year: 00~99 month: 1~12	byte	year, month	2	R
209	40522		day: 1~31	word	day	2	R
20A	40523	Max voltage B-C time	hour: 00~23 minute: 00~59	byte	hour and minute	2	R
20B	40524		second: 00~59	word	second	2	R
20C	40525	Max voltage C-A	0.000 ~ 99999.999	Float	V	4	R
20D	40526						
20E	40527	Max voltage C-A date	year: 00~99 month: 1~12	byte	year, month	2	R
20F	40528		day: 1~31	word	day	2	R
210	40529	Max voltage C-A time	hour: 00~23 minute: 00~59	byte	hour and minute	2	R
211	40530		second: 00~59	word	second	2	R
212	40531	Max voltage A-N	0.000 ~ 99999.999	Float	V	4	R
213	40532						
214	40533	Max voltage A-N date	year: 00~99 month: 1~12	byte	year, month	2	R
215	40534		day: 1~31	word	day	2	R
216	40535	Max voltage A-N time	hour: 00~23 minute: 00~59	byte	hour and minute	2	R
217	40536		second: 00~59	word	second	2	R
218	40537	Max voltage B-N	0.000 ~ 99999.999	Float	V	4	R
219	40538						
21A	40539	Max voltage B-N date	year: 00~99 month: 1~12	byte	year, month	2	R
21B	40540		day: 1~31	word	day	2	R
21C	40541	Max voltage B-N time	hour: 00~23 minute: 00~59	byte	hour and minute	2	R
21D	40542		second: 00~59	word	second	2	R
21E	40543	Max voltage C-N	0.000 ~ 99999.999	Float	V	4	R
21F	40544						
220	40545	Max voltage C-N date	year: 00~99 month: 1~12	byte	year, month	2	R
221	40546		day: 1~31	word	day	2	R

222	40547	Max voltage C-N time	hour: 00~23 minute: 00~59	byte	hour and minute	2	R
223	40548		second: 00~59	word	second	2	R
224	40549	Max current A	0.000 ~ 99999.999	Float	A	4	R
225	40550						
226	40551	Max current A date	year: 00~99 month: 1~12	byte	year, month	2	R
227	40552		day: 1~31	word	day	2	R
228	40553	Max current A time	hour: 00~23 minute: 00~59	byte	hour and minute	2	R
229	40554		second: 00~59	word	second	2	R
22A	40555	Max current B	0.000 ~ 99999.999	Float	A	4	R
22B	40556						
22C	40557	Max current B date	year: 00~99 month: 1~12	byte	year, month	2	R
22D	40558		day: 1~31	word	day	2	R
22E	40559	Max current B time	hour: 00~23 minute: 00~59	byte	hour and minute	2	R
22F	40560		second: 00~59	word	second	2	R
230	40561	Max current C	0.000 ~ 99999.999	Float	A	4	R
231	40562						
232	40563	Max current C date	year: 00~99 month: 1~12	byte	year, month	2	R
233	40564		day: 1~31	word	day	2	R
234	40565	Max current C time	hour: 00~23 minute: 00~59	byte	hour and minute	2	R
235	40566		second: 00~59	word	second	2	R
236	40567	Max current N	0.000 ~ 99999.999	Float	A	4	R
237	40568						
238	40569	Max current N date	year: 00~99 month: 1~12	byte	year, month	2	R
239	40570		day: 1~31	word	day	2	R
23A	40571	Max current N time	hour: 00~23 minute: 00~59	byte	hour and minute	2	R
23B	40572		second: 00~59	word	second	2	R
23C	40573	Max frequency	0.0000 ~ 99.9999	Float	Hz	4	R
23D	40574						
23E	40575	Max frequency date	year: 00~99 month: 1~12	byte	year, month	2	R
23F	40576		day: 1~31	word	day	2	R
240	40577	Max frequency time	hour: 00~23 、 minute: 00~59	byte	hour and minute	2	R
241	40578		second: 00~59	word	second	2	R
242	40579	Max power factor	0.00000 ~ 1.00000	Float		4	R
243	40580						
244	40581	Max power factor date	year: 00~99 month: 1~12	byte	year, month	2	R
245	40582		day: 1~31	word	day	2	R

246	40583	Max power factor time	hour: 00~23 minute: 00~59	byte	hour and minute	2	R
247	40584		second: 00~59	word	second	2	R
248	40585	Max active power total	0.000 ~ 99999.999	Float	kW	4	R
249	40586						
24A	40587	Max active power total date	year: 00~99 month: 1~12	byte	year, month	2	R
24B	40588		day: 1~31	word	day	2	R
24C	40589	Max active power total time	hour: 00~23 minute: 00~59	byte	hour and minute	2	R
24D	40590		second: 00~59	word	second	2	R
24E	40591	Max reactive power total	0.000 ~ 99999.999	Float	kVAR	4	R
24F	40592						
250	40593	Max reactive power total date	year: 00~99 month: 1~12	byte	year, month	2	R
251	40594		day: 1~31	word	day	2	R
252	40595	Max reactive power total time	hour: 00~23 minute: 00~59	byte	hour and minute	2	R
253	40596		second: 00~59	word	second	2	R
254	40597	Max apparent power total	0.000 ~ 99999.999	Float	kVA	4	R
255	40598						
256	40599	Max apparent power total date	year: 00~99 month: 1~12	byte	year, month	2	R
257	40600		day: 1~31	word	day	2	R
258	40601	Max apparent power total time	hour: 00~23 minute: 00~59	byte	hour and minute	2	R
259	40602		second: 00~59	word	second	2	R
25A	40603	Max THD voltage A-B	0.000 ~ 999.999	Float	%	4	R
25B	40604						
25C	40605	Max THD voltage A-B date	year: 00~99 month: 1~12	byte	year, month	2	R
25D	40606		day: 1~31	word	day	2	R
25E	40607	Max THD voltage A-B time	hour: 00~23 minute: 00~59	byte	hour and minute	2	R
25F	40608		second: 00~59	word	second	2	R
260	40609	Max THD voltage B-C	0.000 ~ 999.999	Float	%	4	R
261	40610						
262	40611	Max THD voltage B-C date	year: 00~99 month: 1~12	byte	year, month	2	R
263	40612		day: 1~31	word	day	2	R
264	40613	Max THD voltage B-C time	hour: 00~23 minute: 00~59	byte	hour and minute	2	R
265	40614		second: 00~59	word	second	2	R
266	40615	Max THD voltage C-A	0.000 ~ 999.999	Float	%	4	R
267	40616						
268	40617	Max THD voltage C-A date	year: 00~99 month: 1~12	byte	year, month	2	R
269	40618		day: 1~31	word	day	2	R

26A	40619	Max THD voltage C-A time	hour: 00~23 minute: 00~59	byte	hour and minute	2	R
26B	40620		second: 00~59	word	second	2	R
26C	40621	Max THD voltage A-N	0.000 ~ 999.999	Float	%	4	R
26D	40622						
26E	40623	Max THD voltage A-N date	year: 00~99 month: 1~12	byte	year, month	2	R
26F	40624		day: 1~31	word	day	2	R
270	40625	Max THD voltage A-N time	hour: 00~23 minute: 00~59	byte	hour and minute	2	R
271	40626		second: 00~59	word	second	2	R
272	40627	Max THD voltage B-N	0.000 ~ 999.999	Float	%	4	R
273	40628						
274	40629	Max THD voltage B-N date	year: 00~99 month: 1~12	byte	year, month	2	R
275	40630		day: 1~31	word	day	2	R
276	40631	Max THD voltage B-N time	hour: 00~23 minute: 00~59	byte	hour and minute	2	R
277	40632		second: 00~59	word	second	2	R
278	40633	Max THD voltage C-N	0.000 ~ 999.999	Float	%	4	R
279	40634						
27A	40635	Max THD voltage C-N date	year: 00~99 month: 1~12	byte	year, month	2	R
27B	40636		day: 1~31	word	day	2	R
27C	40637	Max THD voltage C-N time	hour: 00~23 minute: 00~59	byte	hour and minute	2	R
27D	40638		second: 00~59	word	second	2	R
27E	40639	Max avg THD voltage L-L	0.000 ~ 999.999	Float	%	4	R
27F	40640						
280	40641	Max avg THD voltage L-L date	year: 00~99 month: 1~12	byte	year, month	2	R
281	40642		day: 1~31	word	day	2	R
282	40643	Max avg THD voltage L-L time	hour: 00~23 minute: 00~59	byte	hour and minute	2	R
283	40644		second: 00~59	word	second	2	R
284	40645	Max avg THD voltage L-N	0.000 ~ 999.999	Float	%	4	R
285	40646						
286	40647	Max avg THD voltage L-N date	year: 00~99 month: 1~12	byte	year, month	2	R
287	40648		day: 1~31	word	day	2	R
288	40649	Max avg THD voltage L-N time	hour: 00~23 minute: 00~59	byte	hour and minute	2	R
289	40650		second: 00~59	word	second	2	R
28A	40651	Max THD current A	0.000 ~ 999.999	Float	%	4	R
28B	40652						
28C	40653	Max THD current A date	year: 00~99 month: 1~12	byte	year, month	2	R
28D	40654		day: 1~31	word	day	2	R

28E	40655	Max THD current A time	hour: 00~23 minute: 00~59	byte	hour and minute	2	R
28F	40656		second: 00~59	word	second	2	R
290	40657	Max THD current B	0.000 ~ 999.999	Float	%	4	R
291	40658						
292	40659	Max THD current B date	year: 00~99 month: 1~12	byte	year, month	2	R
293	40660		day: 1~31	word	day	2	R
294	40661	Max THD current B time	hour: 00~23 minute: 00~59	byte	hour and minute	2	R
295	40662		second: 00~59	word	second	2	R
296	40663	Max THD current C	0.000 ~ 999.999	Float	%	4	R
297	40664						
298	40665	Max THD current C date	year: 00~99 month: 1~12	byte	year, month	2	R
299	40666		day: 1~31	word	day	2	R
29A	40667	Max THD current C time	hour: 00~23 minute: 00~59	byte	hour and minute	2	R
29B	40668		second: 00~59	word	second	2	R
29C	40669	Max avg THD current	0.000 ~ 999.999	Float	%	4	R
29D	40670						
29E	40671	Max avg THD current date	year: 00~99 month: 1~12	byte	year, month	2	R
29F	40672		day: 1~31	word	day	2	R
2A0	40673	Max avg THD current time	hour: 00~23 minute: 00~59	byte	hour and minute	2	R
2A1	40674		second: 00~59	word	second	2	R
2A2	40675	Max voltage unbalance A-B	0.00 ~ 99.99	Float	%	4	R
2A3	40676						
2A4	40677	Max voltage unbalance A-B date	year: 00~99 month: 1~12	byte	year, month	2	R
2A5	40678		day: 1~31	word	day	2	R
2A6	40679	Max voltage unbalance A-B time	hour: 00~23 minute: 00~59	byte	hour and minute	2	R
2A7	40680		second: 00~59	word	second	2	R
2A8	40681	Max voltage unbalance B-C	0.00 ~ 99.99	Float	%	4	R
2A9	40682						
2AA	40683	Max voltage unbalance B-C date	year: 00~99 month: 1~12	byte	year, month	2	R
2AB	40684		day: 1~31	word	day	2	R
2AC	40685	Max voltage unbalance B-C time	hour: 00~23 minute: 00~59	byte	hour and minute	2	R
2AD	40686		second: 00~59	word	second	2	R
2AE	40687	Max voltage unbalance C-A	0.00 ~ 99.99	Float	%	4	R
2AF	40688						
2B0	40689	Max voltage unbalance C-A date	year: 00~99 month: 1~12	byte	year, month	2	R
2B1	40690		day: 1~31	word	day	2	R

2B2	40691	Max voltage unbalance C-A time	hour: 00~23 minute: 00~59	byte	hour and minute	2	R
2B3	40692		second: 00~59	word	second	2	R
2B4	40693	Max voltage unbalance A-N	0.00 ~ 99.99	Float	%	4	R
2B5	40694						
2B6	40695	Max voltage unbalance A-N date	year: 00~99 month: 1~12	byte	year, month	2	R
2B7	40696		day: 1~31	word	day	2	R
2B8	40697	Max voltage unbalance A-N time	hour: 00~23 minute: 00~59	byte	hour and minute	2	R
2B9	40698		second: 00~59	word	second	2	R
2BA	40699	Max voltage unbalance B-N	0.00 ~ 99.99	Float	%	4	R
2BB	40700						
2BC	40701	Max voltage unbalance B-N date	year: 00~99 month: 1~12	byte	year, month	2	R
2BD	40702		day: 1~31	word	day	2	R
2BE	40703	Max voltage unbalance B-N time	hour: 00~23 minute: 00~59	byte	hour and minute	2	R
2BF	40704		second: 00~59	word	second	2	R
2C0	40705	Max voltage unbalance C-N	0.00 ~ 99.99	Float	%	4	R
2C1	40706						
2C2	40707	Max voltage unbalance C-N date	year: 00~99 month: 1~12	byte	year, month	2	R
2C3	40708		day: 1~31	word	day	2	R
2C4	40709	Max voltage unbalance C-N time	hour: 00~23 minute: 00~59	byte	hour and minute	2	R
2C5	40710		second: 00~59	word	second	2	R
2C6	40711	Max voltage unbalance L-L	0.00 ~ 99.99	Float	%	4	R
2C7	40712						
2C8	40713	Max voltage unbalance L-L date	year: 00~99 month: 1~12	byte	year, month	2	R
2C9	40714		day: 1~31	word	day	2	R
2CA	40715	Max voltage unbalance L-L time	hour: 00~23 minute: 00~59	byte	hour and minute	2	R
2CB	40716		second: 00~59	word	second	2	R
2CC	40717	Max voltage unbalance L-N	0.00 ~ 99.99	Float	%	4	R
2CD	40718						
2CE	40719	Max voltage unbalance L-N date	year: 00~99 month: 1~12	byte	year, month	2	R
2CF	40720		day: 1~31	word	day	2	R
2D0	40721	Max voltage unbalance L-N time	hour: 00~23 minute: 00~59	byte	hour and minute	2	R
2D1	40722		second: 00~59	word	second	2	R
2D2	40723	Max current unbalance A	0.00 ~ 99.99	Float	%	4	R
2D3	40724						

2D4	40725	Max current unbalance A date	year: 00~99 month: 1~12	byte	year, month	2	R
2D5	40726		day: 1~31	word	day	2	R
2D6	40727	Max current unbalance A time	hour: 00~23 minute: 00~59	byte	hour and minute	2	R
2D7	40728		second: 00~59	word	second	2	R
2D8	40729	Max current unbalance B	0.00 ~ 99.99	Float	%	4	R
2D9	40730						
2DA	40731	Max current unbalance B date	year: 00~99 month: 1~12	byte	year, month	2	R
2DB	40732		day: 1~31	word	day	2	R
2DC	40733	Max current unbalance B time	hour: 00~23 minute: 00~59	byte	hour and minute	2	R
2DD	40734		second: 00~59	word	second	2	R
2DE	40735	Max current unbalance C	0.00 ~ 99.99	Float	%	4	R
2DF	40736						
2E0	40737	Max current unbalance C date	year: 00~99 month: 1~12	byte	year, month	2	R
2E1	40738		day: 1~31	word	day	2	R
2E2	40739	Max current unbalance C time	hour: 00~23 minute: 00~59	byte	hour and minute	2	R
2E3	40740		second: 00~59	word	second	2	R
2E4	40741	Max current unbalance	0.00 ~ 99.99	Float	%	2	R
2E5	40742						
2E6	40743	Max current unbalance date	year: 00~99 month: 1~12	byte	year, month	2	R
2E7	40744		day: 1~31	word	day	2	R
2E8	40745	Max current unbalance time	hour: 00~23 minute: 00~59	byte	hour and minute	2	R
2E9	40746		second: 00~59	word	second	2	R
3. Minimum Values: 0300 ~ 03FF							
300	40769	Min voltage A-B	0.000 ~ 99999.999	Float	V	4	R
301	40770						
302	40771	Min voltage A-B date	year: 00~99 month: 1~12	byte	year, month	2	R
303	40772		day: 1~31	word	day	2	R
304	40773	Min voltage A-B time	hour: 00~23 minute: 00~59	byte	hour and minute	2	R
305	40774		second: 00~59	word	second	2	R
306	40775	Min voltage B-C	0.000 ~ 99999.999	Float	V	4	R
307	40776						
308	40777	Min voltage B-C date	year: 00~99 month: 1~12	byte	year, month	2	R
309	40778		day: 1~31	word	day	2	R
30A	40779	Min voltage B-C time	hour: 00~23 minute: 00~59	byte	hour and minute	2	R
30B	40780		second: 00~59	word	second	2	R

30C	40781	Min voltage C-A	0.000 ~ 99999.999	Float	V	4	R
30D	40782						
30E	40783	Min voltage C-A date	year: 00~99 month: 1~12	byte	year, month	2	R
30F	40784		day: 1~31	word	day	2	R
310	40785	Min voltage C-A time	hour: 00~23 minute: 00~59	byte	hour and minute	2	R
311	40786		second: 00~59	word	second	2	R
312	40787	Min voltage A-N	0.000 ~ 99999.999	Float	V	4	R
313	40788						
314	40789	Min voltage A-N date	year: 00~99 month: 1~12	byte	year, month	2	R
315	40790		day: 1~31	word	day	2	R
316	40791	Min voltage A-N time	hour: 00~23 minute: 00~59	byte	hour and minute	2	R
317	40792		second: 00~59	word	second	2	R
318	40793	Min voltage B-N	0.000 ~ 99999.999	Float	V	4	R
319	40794						
31A	40795	Min voltage B-N date	year: 00~99 month: 1~12	byte	year, month	2	R
31B	40796		day: 1~31	word	day	2	R
31C	40797	Min voltage B-N time	hour: 00~23 minute: 00~59	byte	hour and minute	2	R
31D	40798		second: 00~59	word	second	2	R
31E	40799	Min voltage C-N	0.000 ~ 99999.999	Float	V	4	R
31F	40800						
320	40801	Min voltage C-N date	year: 00~99 month: 1~12	byte	year, month	2	R
321	40802		day: 1~31	word	day	2	R
322	40803	Min voltage C-N time	hour: 00~23 minute: 00~59	byte	hour and minute	2	R
323	40804		second: 00~59	word	second	2	R
324	40805	Min current A	0.000 ~ 99999.999	Float	A	4	R
325	40806						
326	40807	Min current A date	year: 00~99 month: 1~12	byte	year, month	2	R
327	40808		day: 1~31	word	day	2	R
328	40809	Min current A time	hour: 00~23 minute: 00~59	byte	hour and minute	2	R
329	40810		second: 00~59	word	second	2	R
32A	40811	Min current B	0.000 ~ 99999.999	Float	A	4	R
32B	40812						
32C	40813	Min current B date	year: 00~99 month: 1~12	byte	year, month	2	R
32D	40814		day: 1~31	word	day	2	R
32E	40815	Min current B time	hour: 00~23 minute: 00~59	byte	hour and minute	2	R
32F	40816		second: 00~59	word	second	2	R

330	40817	Min current C	0.000 ~ 99999.999	Float	A	4	R
331	40818						
332	40819	Min current C date	year: 00~99 month: 1~12	byte	year, month	2	R
333	40820		day: 1~31	word	day	2	R
334	40821	Min current C time	hour: 00~23 minute: 00~59	byte	hour and minute	2	R
335	40822		second: 00~59	word	second	2	R
336	40823	Min current N	0.000 ~ 99999.999	Float	A	4	R
337	40824						
338	40825	Min current N date	year: 00~99 month: 1~12	byte	year, month	2	R
339	40826		day: 1~31	word	day	2	R
33A	40827	Min current N time	hour: 00~23 minute: 00~59	byte	hour and minute	2	R
33B	40828		second: 00~59	word	second	2	R
33C	40829	Min frequency	0.0000 ~ 99.9999	Float	Hz	4	R
33D	40830						
33E	40831	Min frequency date	year: 00~99 month: 1~12	byte	year, month	2	R
33F	40832		day: 1~31	word	day	2	R
340	40833	Min frequency time	hour: 00~23 minute: 00~59	byte	hour and minute	2	R
341	40834		second: 00~59	word	second	2	R
342	40835	Min power factor	0.00000 ~ 1.00000	Float		4	R
343	40836						
344	40837	Min power factor date	year: 00~99 month: 1~12	byte	year, month	2	R
345	40838		day: 1~31	word	day	2	R
346	40839	Min power factor time	hour: 00~23 minute: 00~59	byte	hour and minute	2	R
347	40840		second: 00~59	word	second	2	R
348	40841	Min total active power	0.000 ~ 99999.999	Float	kW	4	R
349	40842						
34A	40843	Min total active power date	year: 00~99 month: 1~12	byte	year, month	2	R
34B	40844		day: 1~31	word	day	2	R
34C	40845	Min total active power time	hour: 00~23 minute: 00~59	byte	hour and minute	2	R
34D	40846		second: 00~59	word	second	2	R
34E	40847	Min total reactive power	0.000 ~ 99999.999	Float	kVAR	4	R
34F	40848						
350	40849	Min total reactive power date	year: 00~99 month: 1~12	byte	year, month	2	R
351	40850		day: 1~31	word	day	2	R
352	40851	Min total reactive power time	hour: 00~23 minute: 00~59	byte	hour and minute	2	R
353	40852		second: 00~59	word	second	2	R

354	40853	Min total apparent power	0.000 ~ 99999.999	Float	kVA	4	R
355	40854						
356	40855	Min total apparent power date	year: 00~99 month: 1~12	byte	year, month	2	R
357	40856		day: 1~31	word	day	2	R
358	40857	Min total apparent power time	hour: 00~23 minute: 00~59	byte	hour and minute	2	R
359	40858		second: 00~59	word	second	2	R
35A	40859	Min THD voltage A-B	0.000 ~ 999.999	Float	%	4	R
35B	40860						
35C	40861	Min THD voltage A-B date	year: 00~99 month: 1~12	byte	year, month	2	R
35D	40862		day: 1~31	word	day	2	R
35E	40863	Min THD voltage A-B time	hour: 00~23 minute: 00~59	byte	hour and minute	2	R
35F	40864		second: 00~59	word	second	2	R
360	40865	Min THD voltage B-C	0.000 ~ 999.999	Float	%	4	R
361	40866						
362	40867	Min THD voltage B-C date	year: 00~99 month: 1~12	byte	year, month	2	R
363	40868		day: 1~31	word	day	2	R
364	40869	Min THD voltage B-C time	hour: 00~23 minute: 00~59	byte	hour and minute	2	R
365	40870		second: 00~59	word	second	2	R
366	40871	Min THD voltage C-A	0.000 ~ 999.999	Float	%	4	R
367	40872						
368	40873	Min THD voltage C-A date	year: 00~99 month: 1~12	byte	year, month	2	R
369	40874		day: 1~31	word	day	2	R
36A	40875	Min THD voltage C-A time	hour: 00~23 minute: 00~59	byte	hour and minute	2	R
36B	40876		second: 00~59	word	second	2	R
36C	40877	Min THD voltage A-N	0.000 ~ 999.999	Float	%	4	R
36D	40878						
36E	40879	Min THD voltage A-N date	year: 00~99 month: 1~12	byte	year, month	2	R
36F	40880		day: 1~31	word	day	2	R
370	40881	Min THD voltage A-N time	hour: 00~23 minute: 00~59	byte	hour and minute	2	R
371	40882		second: 00~59	word	second	2	R
372	40883	Min THD voltage B-N	0.000 ~ 999.999	Float	%	4	R
373	40884						
374	40885	Min THD voltage B-N date	year: 00~99 month: 1~12	byte	year, month	2	R
375	40886		day: 1~31	word	day	2	R
376	40887	Min THD voltage B-N time	hour: 00~23 minute: 00~59	byte	hour and minute	2	R
377	40888		second: 00~59	word	second	2	R

378	40889	Min THD voltage C-N	0.000 ~ 999.999	Float	%	4	R
379	40890						
37A	40891	Min THD voltage C-N date	year: 00~99 month: 1~12	byte	year, month	2	R
37B	40892		day: 1~31	word	day	2	R
37C	40893	Min THD voltage C-N time	hour: 00~23 minute: 00~59	byte	hour and minute	2	R
37D	40894		second: 00~59	word	second	2	R
37E	40895	Min avg THD voltage L-L	0.000 ~ 999.999	Float	%	4	R
37F	40896						
380	40897	Min avg THD voltage L-L date	year: 00~99 month: 1~12	byte	year, month	2	R
381	40898		day: 1~31	word	day	2	R
382	40899	Min avg THD voltage L-L time	hour: 00~23 minute: 00~59	byte	hour and minute	2	R
383	40900		second: 00~59	word	second	2	R
384	40901	Min avg THD voltage L-N	0.000 ~ 999.999	Float	%	4	R
385	40902						
386	40903	Min avg THD voltage L-N date	year: 00~99 month: 1~12	byte	year, month	2	R
387	40904		day: 1~31	word	day	2	R
388	40905	Min avg THD voltage L-N time	hour: 00~23 minute: 00~59	byte	hour and minute	2	R
389	40906		second: 00~59	word	second	2	R
38A	40907	Min THD current A	0.000 ~ 999.999	Float	%	4	R
38B	40908						
38C	40909	Min THD current A date	year: 00~99 month: 1~12	byte	year, month	2	R
38D	40910		day: 1~31	word	day	2	R
38E	40911	Min THD current A time	hour: 00~23 minute: 00~59	byte	hour and minute	2	R
38F	40912		second: 00~59	word	second	2	R
390	40913	Min THD current B	0.000 ~ 999.999	Float	%	4	R
391	40914						
392	40915	Min THD current B date	year: 00~99 month: 1~12	byte	year, month	2	R
393	40916		day: 1~31	word	day	2	R
394	40917	Min THD current B time	hour: 00~23 minute: 00~59	byte	hour and minute	2	R
395	40918		second: 00~59	word	second	2	R
396	40919	Min THD current C	0.000 ~ 999.999	Float	%	4	R
397	40920						
398	40921	Min THD current C date	year: 00~99 month: 1~12	byte	year, month	2	R
399	40922		day: 1~31	word	day	2	R
39A	40923	Min THD current C time	hour: 00~23 minute: 00~59	byte	hour and minute	2	R
39B	40924		second: 00~59	word	second	2	R

39C	40925	Min avg THD current	0.000 ~ 999.999	Float	%	4	R
39D	40926						
39E	40927	Min avg THD current date	year: 00~99 month: 1~12	byte	year, month	2	R
39F	40928		day: 1~31	word	day	2	R
3A0	40929	Min avg THD current time	hour: 00~23 minute: 00~59	byte	hour and minute	2	R
3A1	40930		second: 00~59	word	second	2	R
3A2	40931	Min voltage unbalance A-B	0.00 ~ 99.99	Float	%	4	R
3A3	40932						
3A4	40933	Min voltage unbalance A-B date	year: 00~99 month: 1~12	byte	year, month	2	R
3A5	40934		day: 1~31	word	day	2	R
3A6	40935	Min voltage unbalance A-B time	hour: 00~23 minute: 00~59	byte	hour and minute	2	R
3A7	40936		second: 00~59	word	second	2	R
3A8	40937	Min voltage unbalance B-C	0.00 ~ 99.99	Float	%	4	R
3A9	40938						
3AA	40939	Min voltage unbalance B-C date	year: 00~99 month: 1~12	byte	year, month	2	R
3AB	40940		day: 1~31	word	day	2	R
3AC	40941	Min voltage unbalance B-C time	hour: 00~23 minute: 00~59	byte	hour and minute	2	R
3AD	40942		second: 00~59	word	second	2	R
3AE	40943	Min voltage unbalance C-A	0.00 ~ 99.99	Float	%	4	R
3AF	40944						
3B0	40945	Min voltage unbalance C-A date	year: 00~99 month: 1~12	byte	year, month	2	R
3B1	40946		day: 1~31	word	day	2	R
3B2	40947	Min voltage unbalance C-A time	hour: 00~23 minute: 00~59	byte	hour and minute	2	R
3B3	40948		second: 00~59	word	second	2	R
3B4	40949	Min voltage unbalance A-N	0.00 ~ 99.99	Float	%	4	R
3B5	40950						
3B6	40951	Min voltage unbalance A-N date	year: 00~99 month: 1~12	byte	year, month	2	R
3B7	40952		day: 1~31	word	day	2	R
3B8	40953	Min voltage unbalance A-N time	hour: 00~23 minute: 00~59	byte	hour and minute	2	R
3B9	40954		second: 00~59	word	second	2	R
3BA	40955	Min voltage unbalance B-N	0.00 ~ 99.99	Float	%	4	R
3BB	40956						
3BC	40957	Min voltage unbalance B-N date	year: 00~99 month: 1~12	byte	year, month	2	R
3BD	40958		day: 1~31	word	day	2	R
3BE	40959	Min voltage unbalance B-N time	hour: 00~23 minute: 00~59	byte	hour and minute	2	R
3BF	40960		second: 00~59	word	second	2	R

3C0	40961	Min voltage unbalance C-N	0.00 ~ 99.99	Float	%	4	R
3C1	40962						
3C2	40963	Min voltage unbalance C-N date	year: 00~99 month: 1~12	byte	year, month	2	R
3C3	40964		day: 1~31	word	day	2	R
3C4	40965	Min voltage unbalance C-N time	hour: 00~23 minute: 00~59	byte	hour and minute	2	R
3C5	40966		second: 00~59	word	second	2	R
3C6	40967	Min voltage unbalance L-L	0.00 ~ 99.99	Float	%	4	R
3C7	40968						
3C8	40969	Min voltage unbalance L-L date	year: 00~99 month: 1~12	byte	year, month	2	R
3C9	40970		day: 1~31	word	day	2	R
3CA	40971	Min voltage unbalance L-L time	hour: 00~23 minute: 00~59	byte	hour and minute	2	R
3CB	40972		second: 00~59	word	second	2	R
3CC	40973	Min voltage unbalance L-N	0.00 ~ 99.99	Float	%	4	R
3CD	40974						
3CE	40975	Min voltage unbalance L-N date	year: 00~99 month: 1~12	byte	year, month	2	R
3CF	40976		day: 1~31	word	day	2	R
3D0	40977	Min voltage unbalance L-N time	hour: 00~23 minute: 00~59	byte	hour and minute	2	R
3D1	40978		second: 00~59	word	second	2	R
3D2	40979	Min current unbalance A	0.00 ~ 99.99	Float	%	4	R
3D3	40980						
3D4	40981	Min current unbalance A date	year: 00~99 month: 1~12	byte	year, month	2	R
3D5	40982		day: 1~31	word	day	2	R
3D6	40983	Min current unbalance A time	hour: 00~23 minute: 00~59	byte	hour and minute	2	R
3D7	40984		second: 00~59	word	second	2	R
3D8	40985	Min current unbalance B	0.00 ~ 99.99	Float	%	4	R
3D9	40986						
3DA	40987	Min current unbalance B date	year: 00~99 month: 1~12	byte	year, month	2	R
3DB	40988		day: 1~31	word	day	2	R
3DC	40989	Min current unbalance B time	hour: 00~23 minute: 00~59	byte	hour and minute	2	R
3DD	40990		second: 00~59	word	second	2	R
3DE	40991	Min current unbalance C	0.00 ~ 99.99	Float	%	4	R
3DF	40992						
3E0	40993	Min current unbalance C date	year: 00~99 month: 1~12	byte	year, month	2	R
3E1	40994		day: 1~31	word	day	2	R
3E2	40995	Min current unbalance C time	hour: 00~23 minute: 00~59	byte	hour and minute	2	R
3E3	40996		second: 00~59	word	second	2	R

3E4	40997	Min current unbalance	0.00 ~ 99.99	Float	%	2	R
3E5	40998						
3E6	40999	Min current unbalance date	year: 00~99 month: 1~12	byte	year, month	2	R
3E7	41000		day: 1~31	word	day	2	R
3E8	41001	Min current unbalance time	hour: 00~23 minute: 00~59	byte	hour and minute	2	R
3E9	41002		second: 00~59	word	second	2	R
4. Alarm: 0400 ~ 04FF							
400	41025	Over current alarm status	0: Cleared 1: Triggered	word		2	R
401	41026	Over current alarm counter	1~255	word	times	2	R
402	41027	Over current alarm date	year: 00~99 month: 1~12	byte	year, month	2	R
403	41028		day: 1~31	word	day	2	R
404	41029	Over current alarm time	hour: 00~23 minute: 00~59	byte	hour and minute	2	R
405	41030		second: 00~59	word	second	2	R
406	41031	Under current alarm status	0: Cleared 1: Triggered	word		2	R
407	41032	Under current alarm counter	1~255	word	times	2	R
408	41033	Under current alarm date	year: 00~99 month: 1~12	byte	year, month	2	R
409	41034		day: 1~31	word	day	2	R
40A	41035	Under current alarm time	hour: 00~23 minute: 00~59	byte	hour and minute	2	R
40B	41036		second: 00~59	word	second	2	R
40C	41037	Over neutral current alarm status	0: Cleared 1: Triggered	word		2	R
40D	41038	Over neutral current alarm counter	1~255	word	times	2	R
40E	41039	Over neutral current alarm date	year: 00~99 month: 1~12	byte	year, month	2	R
40F	41040		day: 1~31	word	day	2	R
410	41041	Over neutral current alarm time	hour: 00~23 minute: 00~59	byte	hour and minute	2	R
411	41042		second: 00~59	word	second	2	R
412	41043	Over voltage L-L alarm status	0: Cleared 1: Triggered	word		2	R
413	41044	Over voltage L-L alarm counter	1~255	word	times	2	R
414	41045	Over voltage L-L alarm date	year: 00~99 month: 1~12	byte	year, month	2	R
415	41046		day: 1~31	word	day	2	R
416	41047	Over voltage L-L alarm time	hour: 00~23 minute: 00~59	byte	hour and minute	2	R
417	41048		second: 00~59	word	second	2	R
418	41049	Under voltage L-L alarm status	0: Cleared 1: Triggered	word		2	R
419	41050	Under voltage L-L alarm counter	1~255	word	times	2	R
41A	41051	Under voltage L-L alarm date	year: 00~99 month: 1~12	byte	year, month	2	R
41B	41052		day: 1~31	word	day	2	R

41C	41053	Under voltage L-L alarm time	hour: 00~23 minute: 00~59	byte	hour and minute	2	R
41D	41054		second: 00~59	word	second	2	R
41E	41055	Over voltage L-N alarm status	0: Cleared 1: Triggered	word		2	R
41F	41056	Over voltage L-N alarm counter	1~255	word	times	2	R
420	41057	Over voltage L-N alarm date	year: 00~99 month: 1~12	byte	year, month	2	R
421	41058		day: 1~31	word	day	2	R
422	41059	Over voltage L-N alarm time	hour: 00~23 minute: 00~59	byte	hour and minute	2	R
423	41060		second: 00~59	word	second	2	R
424	41061	Under voltage L-N alarm status	0: Cleared 1: Triggered	word		2	R
425	41062	Under voltage L-N alarm counter	1~255	word	times	2	R
426	41063	Under voltage L-N alarm date	year: 00~99 month: 1~12	byte	year, month	2	R
427	41064		day: 1~31	word	day	2	R
428	41065	Under voltage L-N alarm time	hour: 00~23 minute: 00~59	byte	hour and minute	2	R
429	41066		second: 00~59	word	second	2	R
42A	41067	Over voltage unbalance alarm status	0: Cleared 1: Triggered	word		2	R
42B	41068	Over voltage unbalance alarm counter	1~255	word	times	2	R
42C	41069	Over voltage unbalance alarm date	year: 00~99 month: 1~12	byte	year, month	2	R
42D	41070		day: 1~31	word	day	2	R
42E	41071	Over voltage unbalance alarm time	hour: 00~23 minute: 00~59	byte	hour and minute	2	R
42F	41072		second: 00~59	word	second	2	R
430	41073	Over current unbalance alarm status	0: Cleared 1: Triggered	word		2	R
431	41074	Over current unbalance alarm counter	1~255	word	times	2	R
432	41075	Over current unbalance alarm date	year: 00~99 month: 1~12	byte	year, month	2	R
433	41076		day: 1~31	word	day	2	R
434	41077	Over current unbalance alarm time	hour: 00~23 minute: 00~59	byte	hour and minute	2	R
435	41078		second: 00~59	word	second	2	R
436	41079	Over active power alarm status	0: Cleared 1: Triggered	word		2	R
437	41080	Over active power alarm counter	1~255	word	times	2	R
438	41081	Over active power alarm date	year: 00~99 month: 1~12	byte	year, month	2	R
439	41082		day: 1~31	word	day	2	R
43A	41083	Over active power alarm time	hour: 00~23 minute: 00~59	byte	hour and minute	2	R
43B	41084		second: 00~59	word	second	2	R
43C	41085	Over reactive power alarm status	0: Cleared 1: Triggered	word		2	R
43D	41086	Over reactive power alarm counter	1~255	word	times	2	R

43E	41087	Over reactive power alarm date	year: 00~99 month: 1~12	byte	year, month	2	R
43F	41088		day: 1~31	word	day	2	R
440	41089	Over reactive power alarm time	hour: 00~23 minute: 00~59	byte	hour and minute	2	R
441	41090		second: 00~59	word	second	2	R
442	41091	Over apparent power alarm status	0: Cleared 1: Triggered	word		2	R
443	41092	Over apparent power alarm counter	1~255	word	times	2	R
444	41093	Over apparent power alarm date	year: 00~99 month: 1~12	byte	year, month	2	R
445	41094		day: 1~31	word	day	2	R
446	41095	Over apparent power alarm time	hour: 00~2 minute: 00~59	byte	hour and minute	2	R
447	41096		second: 00~59	word	second	2	R
448	41097	Lead power factor alarm status	0: Cleared 1: Triggered	word		2	R
449	41098	Lead power factor alarm counter	1~255	word	times	2	R
44A	41099	Lead power factor alarm date	year: 00~99 month: 1~12	byte	year, month	2	R
44B	41100		day: 1~31	word	day	2	R
44C	41101	Lead power factor alarm time	hour: 00~23 minute: 00~59	byte	hour and minute	2	R
44D	41102		second: 00~59	word	second	2	R
44E	41103	Lag power factor alarm status	0: Cleared 1: Triggered	word		2	R
44F	41104	Lag power factor alarm counter	1~255	word	times	2	R
450	41105	Lag power factor alarm date	year: 00~99 month: 1~12	byte	year, month	2	R
451	41106		day: 1~31	word	day	2	R
452	41107	Lag power factor alarm time	hour: 00~23 minute: 00~59	byte	hour and minute	2	R
453	41108		second: 00~59	word	second	2	R
454	41109	Lead displacement power factor alarm status	0: Cleared 1: Triggered	word		2	R
455	41110	Lead displacement power factor alarm counter	1~255	word	times	2	R
456	41111	Lead displacement power factor alarm date	year: 00~99 month: 1~12	byte	year, month	2	R
457	41112		day: 1~31	word	day	2	R
458	41113	Lead displacement power factor alarm time	hour: 00~23 minute: 00~59	byte	hour and minute	2	R
459	41114		second: 00~59	word	second	2	R
45A	41115	Lag displacement power factor alarm status	0: Cleared 1: Triggered	word		2	R
45B	41116	Lag displacement power factor alarm counter	1~255	word	times	2	R
45C	41117	Lag displacement power factor alarm date	year: 00~99 month: 1~12	byte	year, month	2	R
45D	41118		day: 1~31	word	day	2	R
45E	41119	Lag displacement power factor alarm time	hour: 00~23 minute: 00~59	byte	hour and minute	2	R
45F	41120		second: 00~59	word	second	2	R
460	41121	Over current demand alarm status	0: Cleared 1: Triggered	word		2	R

461	41122	Over current demand alarm counter	1~255	word	times	2	R
462	41123	Over current demand alarm date	year: 00~99 month: 1~12	byte	year, month	2	R
463	41124		day: 1~31	word	day	2	R
464	41125	Over current demand alarm time	hour: 00~23 minute: 00~59	byte	hour and minute	2	R
465	41126		second: 00~59	word	second	2	R
466	41127	Over active power demand alarm status	0: Cleared 1: Triggered	word		2	R
467	41128	Over active power demand alarm counter	1~255	word	times	2	R
468	41129	Over active power demand alarm date	year: 00~99 month: 1~12	byte	year, month	2	R
469	41130		day: 1~31	word	day	2	R
46A	41131	Over active power demand alarm time	hour: 00~23 minute: 00~59	byte	hour and minute	2	R
46B	41132		second: 00~59	word	second	2	R
46C	41133	Over reactive power demand alarm status	0: Cleared 1: Triggered	word		2	R
46D	41134	Over reactive power demand alarm counter	1~255	word	times	2	R
46E	41135	Over reactive power demand alarm date	year: 00~99 month: 1~12	byte	year, month	2	R
46F	41136		day: 1~31	word	day	2	R
470	41137	Over reactive power demand alarm time	hour: 00~23 minute: 00~59	byte	hour and minute	2	R
471	41138		second: 00~59	word	second	2	R
472	41139	Over apparent power demand alarm status	0: Cleared 1: Triggered	word		2	R
473	41140	Over apparent power demand alarm counter	1~255	word	times	2	R
474	41141	Over apparent power demand alarm date	year: 00~99 month: 1~12	byte	year, month	2	R
475	41142		day: 1~31	word	day	2	R
476	41143	Over apparent power demand alarm time	hour: 00~23 minute: 00~59	byte	hour and minute	2	R
477	41144		second: 00~59	word	second	2	R
478	41145	Over frequency alarm status	0: Cleared 1: Triggered	word		2	R
479	41146	Over frequency alarm counter	1~255	word	times	2	R
47A	41147	Over frequency alarm date	year: 00~99 month: 1~12	byte	year, month	2	R
47B	41148		day: 1~31	word	day	2	R
47C	41149	Over frequency alarm time	hour: 00~23 minute: 00~59	byte	hour and minute	2	R
47D	41150		second: 00~59	word	second	2	R
47E	41151	Under frequency alarm status	0: Cleared 1: Triggered	word		2	R
47F	41152	Under frequency alarm counter	1~255	word	times	2	R
480	41153	Under frequency alarm date	year: 00~99 month: 1~12	byte	year, month	2	R
481	41154		day: 1~31	word	day	2	R
482	41155	Under frequency alarm time	hour: 00~23 minute: 00~59	byte	hour and minute	2	R
483	41156		second: 00~59	word	second	2	R

484	41157	Over THD voltage alarm status	0: Cleared 1: Triggered	word		2	R
485	41158	Over THD voltage alarm counter	1~255	word	times	2	R
486	41159	Over THD voltage alarm date	year: 00~99 month: 1~12	byte	year, month	2	R
487	41160		day: 1~31	word	day	2	R
488	41161	Over THD voltage alarm time	hour: 00~23 minute: 00~59	byte	hour and minute	2	R
489	41162		second: 00~59	word	second	2	R
48A	41163	Over THD current alarm status	0: Cleared 1: Triggered	word		2	R
48B	41164	Over THD current alarm counter	1~255	word	times	2	R
48C	41165	Over THD current alarm date	year: 00~99 month: 1~12	byte	year, month	2	R
48D	41166		day: 1~31	word	day	2	R
48E	41167	Over THD current alarm time	hour: 00~23 minute: 00~59	byte	hour and minute	2	R
48F	41168		second: 00~59	word	second	2	R
490	41169	Over phase loss alarm status	0: Cleared 1: Triggered	word		2	R
491	41170	Over phase loss alarm counter	1~255	word	times	2	R
492	41171	Over phase loss alarm date	year: 00~99 month: 1~12	byte	year, month	2	R
493	41172		day: 1~31	word	day	2	R
494	41173	Over phase loss alarm time	hour: 00~23 minute: 00~59	byte	hour and minute	2	R
495	41174		second: 00~59	word	second	2	R
496	41175	Meter reset alarm status	0: Cleared 1: Triggered	word		2	R
497	41176	Meter reset alarm counter	1~255	word	times	2	R
498	41177	Meter reset alarm date	year: 00~99 month: 1~12	byte	year, month	2	R
499	41178		day: 1~31	word	day	2	R
49A	41179	Meter reset alarm time	hour: 00~23 minute: 00~59	byte	hour and minute	2	R
49B	41180		second: 00~59	word	second	2	R
49C	41181	Phase reversal alarm status	0: Cleared 1: Triggered	word		2	R
49D	41182	Phase reversal alarm counter	1~255	word	times	2	R
49E	41183	Phase reversal alarm date	year: 00~99 month: 1~12	byte	year, month	2	R
49F	41184		day: 1~31	word	day	2	R
4A0	41185	Phase reversal alarm time	hour: 00~23 minute: 00~59	byte	hour and minute	2	R
4A1	41186		second: 00~59	word	second	2	R
4A2	41187	Over DUI alarm status	0: Cleared 1: Triggered	word		2	R
4A3	41188	Over DUI alarm counter	1~255	word	times	2	R
4A4	41189	Over DUI alarm date	year: 00~99 month: 1~12	byte	year, month	2	R
4A5	41190		day: 1~31	word	day	2	R

4A6	41191	Over DUI alarm time	hour: 00~23 minute: 00~59	byte	hour and minute	2	R
4A7	41192		second: 00~59	word	second	2	R
4A8	41193	Over EUI alarm status	0: Cleared 1: Triggered	word		2	R
4A9	41194	Over EUI alarm counter	1~255	word	times	2	R
4AA	41195	Over EUI alarm date	year: 00~99 month: 1~12	byte	year, month	2	R
4AB	41196		day: 1~31	word	day	2	R
4AC	41197	Over EUI alarm time	hour: 00~23 minute: 00~59	byte	hour and minute	2	R
4AD	41198		second: 00~59	word	second	2	R
5. Advanced Settings: 0500 ~ 05FF							
500	41281	Floor area	1~65536	word		2	R / W
501	41282	Data record interval	minute: 00~60 second: 00~59 0: Disable	byte	minutesecond	2	R / W
502	41283	Auto metering I, enable	0: Disable 1: Enable	word		2	R / W
503		Reserved					
504	41285	Auto metering I, date	day: 1~31	word	day	2	R / W
505		Reserved					
506		Reserved					
507	41288	Auto metering II, enable	0: Disable 1: Enable	word		2	R / W
508		Reserved					
509	41290	Auto metering II, date	day: 1~31	word	day	2	R / W
50A		Reserved					
50B		Reserved					
50C	41293	Parameter grouping #1 setting	0x100 ~ 0x1E7	word		2	R / W
50D	41294	Parameter grouping #2 setting	0x100 ~ 0x1E7	word		2	R / W
⋮	⋮	⋮	0x100 ~ 0x1E7	word		2	R / W
551	41362	Parameter grouping #70 setting	0x100 ~ 0x1E7	word		2	R / W
552	41363	Reset energy date	year: 00~99 month: 1~12	byte	year, month	2	R
553	41364	Reset energy date	day: 1~31	word	day	2	R
554	41365	Reset energy time	hour: 00~23 minute: 00~59	byte	hour and minute	2	R
555	41366	Reset energy time	second: 00~59	word	second	2	R
556	41367	Data log start date	year: 00~99 month: 1~12	byte	year, month	2	R
557	41368		day: 1~31	word	day	2	R
558	41369	Data log start time	hour: 00~23 minute: 00~59	byte	hour and minute	2	R
559	41370		second: 00~59	word	second	2	R
55A	41371	Max/Min auto reset interval	0: disable 1: day 2: month 3: year	word		2	R / W

55B	41372	Parameter #1 for data log	1: voltage L-N 2: voltage L-L 3: current 4: current, Neutral 5: power factor 6: displacement power factor 7: active power 8: reactive power 9: apparent power 10: active energy delivered 11: active energy received 12: reactive energy delivered 13: reactive energy received 14: apparent energy delivered 15: apparent energy received 16: THD voltage 17: THD current	word		2	R / W
55C	41373	Parameter #2 for data log		word		2	R / W
55D	41374	Parameter #3 for data log		word		2	R / W
55E	41375	Parameter #4 for data log		word		2	R / W
55F	41376	Parameter #5 for data log		word		2	R / W
560	41377	Parameter #6 for data log		word		2	R / W
561	41378	Parameter #7 for data log		word		2	R / W
562	41379	Parameter #8 for data log		word		2	R / W
563	41380	Parameter #9 for data log		word		2	R / W
564	41381	Parameter #10 for data log		word		2	R / W
565	41382	Parameter #11 for data log		word		2	R / W
566	41383	Parameter #12 for data log		word		2	R / W
567	41384	Parameter #13 for data log		word		2	R / W
568	41385	Parameter #14 for data log		word		2	R / W
569	41386	Parameter #15 for data log		word		2	R / W
56A	41387	Parameter #16 for data log		word		2	R / W
56B	41388	Parameter #17 for data log		word		2	R / W

6. Parameter grouping: 0600~06FF

600	41537	Parameter grouping #1 data				2	R
601	41538	Parameter grouping #2 data				2	R
:	:	:				2	R
645	41606	Parameter grouping #70 data				2	R

7. Harmonic: 0700~07FF

0700		1 st THD voltage A-N	0.000 ~ 999.999	Float	%	4	R
		:	0.000 ~ 999.999	Float	%	4	R
0701		11 th THD voltage A-N	0.000 ~ 999.999	Float	%	4	R
		:	0.000 ~ 999.999	Float	%	4	R
0702		21 st THD voltage A-N	0.000 ~ 999.999	Float	%	4	R
		:	0.000 ~ 999.999	Float	%	4	R
		31 st THD voltage A-N	0.000 ~ 999.999	Float	%	4	R
0703		1 st THD voltage B-N	0.000 ~ 999.999	Float	%	4	R
		:	0.000 ~ 999.999	Float	%	4	R
0704		11 th THD voltage B-N	0.000 ~ 999.999	Float	%	4	R
		:	0.000 ~ 999.999	Float	%	4	R

0705		21 st THD voltage B-N	0.000 ~ 999.999	Float	%	4	R
		⋮	0.000 ~ 999.999	Float	%	4	R
		31 st THD voltage B-N	0.000 ~ 999.999	Float	%	4	R
0706		1 st THD voltage C-N	0.000 ~ 999.999	Float	%	4	R
		⋮	0.000 ~ 999.999	Float	%	4	R
0707		11 th THD voltage C-N	0.000 ~ 999.999	Float	%	4	R
		⋮	0.000 ~ 999.999	Float	%	4	R
0708		21 st THD voltage C-N	0.000 ~ 999.999	Float	%	4	R
		⋮	0.000 ~ 999.999	Float	%	4	R
		31 st THD voltage C-N	0.000 ~ 999.999	Float	%	4	R
0709		1 st THD current A	0.000 ~ 999.999	Float	%	4	R
		⋮	0.000 ~ 999.999	Float	%	4	R
070A		11 th THD current A	0.000 ~ 999.999	Float	%	4	R
		⋮	0.000 ~ 999.999	Float	%	4	R
070B		21 st THD current A	0.000 ~ 999.999	Float	%	4	R
		⋮	0.000 ~ 999.999	Float	%	4	R
		31 st THD current A	0.000 ~ 999.999	Float	%	4	R
070C		1 st THD current B	0.000 ~ 999.999	Float	%	4	R
		⋮	0.000 ~ 999.999	Float	%	4	R
070D		11 th THD current B	0.000 ~ 999.999	Float	%	4	R
		⋮	0.000 ~ 999.999	Float	%	4	R
070E		21 st THD current B	0.000 ~ 999.999	Float	%	4	R
		⋮	0.000 ~ 999.999	Float	%	4	R
		31 st THD current B	0.000 ~ 999.999	Float	%	4	R
070F		1 st THD current C	0.000 ~ 999.999	Float	%	4	R
		⋮	0.000 ~ 999.999	Float	%	4	R
0710		11 th THD current C	0.000 ~ 999.999	Float	%	4	R
		⋮	0.000 ~ 999.999	Float	%	4	R
0711		21 st THD current C	0.000 ~ 999.999	Float	%	4	R
		⋮	0.000 ~ 999.999	Float	%	4	R
		31 st THD current C	0.000 ~ 999.999	Float	%	4	R

8. Data Log: 0800 ~ B6FF

0800		data log of 3 intervals					R
0801		data log of 3 intervals					R
0802		data log of 3 intervals					R
⋮		⋮					R

⋮							R
B6FF		data log of 3 intervals					R
Alarm History							
B700		Alarm History 1	1 ~ 29(high byte, category) 1 ~ 255(low byte, number of times)	byte		2	R
B701		Alarm History 2	1 ~ 29(high byte, category) 1 ~ 255(low byte, number of times)	byte		2	R
B702		Alarm History 3	1 ~ 29(high byte, category) 1 ~ 255(low byte, number of times)	byte		2	R
⋮				byte		2	R
B8F3		Alarm History 500	1 ~ 29(high byte, category) 1 ~ 255(low byte, number of times)	byte		2	R
B8F4		alarm 01 date	year: 00~99 month: 1~12	byte	year, month	2	R
B8F5			day: 1~31	word	day	2	R
B8F6		alarm 01 time	hour: 00~23 minute: 00~59	byte	hour and minute	2	R
B8F7			second: 00~59	word	second	2	R
B8F8		alarm 02 date	year: 00~99 month: 1~12	byte	year, month	2	R
B8F9			day: 1~31	word	day	2	R
B8FA		alarm 02 time	hour: 00~23 minute: 00~59	byte	hour and minute	2	R
B8FB			second: 00~59	word	second	2	R
B8FC		alarm 03 date	year: 00~99 month: 1~12	byte	year, month	2	R
B8FD			day: 1~31	word	day	2	R
B8FE		alarm 03 time	hour: 00~23 minute: 00~59	byte	hour and minute	2	R
B8FF			second: 00~59	word	second	2	R
⋮				byte	year, month	2	R
C0C0		alarm 500 date	year: 00~99 month: 1~12	byte	year, month	2	R
C0C1			day: 1~31	word	day	2	R
C0C2		alarm 500 time	hour: 00~23 minute: 00~59	byte	hour and minute	2	R
C0C3			second: 00~59	word	second	2	R

Messages of Abnormal Operations

Under abnormal communications, the power meter can send out messages via MODBUS (codes shown below), informing the reason why the main station experienced abnormal situation.

Abnormal Message Code	Name	Description
0x01	Illegal Function	Illegal functional code
0x02	Illegal Data Address	Address of data read or written is illegal
0x03	Illegal Data Value	Illegal data format (such as incorrect data length)
0x04	Slave Device Failure	Slave device fails to support the commands

Based on start/stop status for the 29 types of alarm settings (register location 0x3E~0xFF) under abnormal situations, the power meter records the type and time of the alarm occurred in the register location 0x0A01~0x0ACF. The types of alarms and their descriptions are as follows:

Alarm Number	Alarm Type	Description
1	Over-current	Average current is higher than alert value
2	Under current	Average current is lower than alert value
3	Over neutral current	Neutral current is higher than alert value
4	Over voltage L-L	Average voltage L-L is higher than alert value
5	Under voltage L-L	Average voltage L-L is lower than alert value
6	Over voltage L-N	Average voltage L-N is higher than alert value
7	Under voltage L-N	Average voltage L-N is lower than alert value
8	Over voltage unbalance	Voltage unbalance is higher than alert value
9	Over current unbalance	Current unbalance is lower than alert value
10	Over active power	Total active power is higher than alert value
11	Over reactive power	Total reactive power is higher than alert value
12	Over apparent power	Total apparent power is higher than alert value
13	Power factor (leading)	Power factor under leading load is lower than alert value
14	Power factor (lagging)	Power factor under lagging load is lower than alert value
15	Displacement power factor (leading)	Displacement power factor under leading load is lower than alert value
16	Displacement power factor (lagging)	Displacement power factor under lagging load is lower than alert value
17	Over current demand	Current demand is higher than alert value

18	Over active power demand	Active power demand is higher than alert value
19	Over reactive power demand	Reactive power demand is higher than alert value
20	Over apparent power demand	Apparent power demand is higher than alert value
21	Over-frequency	System frequency is higher than alert value
22	Under frequency	System frequency is lower than alert value
23	Over THD voltage	Total harmonic distortion for voltage is higher than alert value
24	Over THD current	Total harmonic distortion for current is higher than alert value
25	Phase loss	When the system is unbalanced, voltage is lower than alert value.
26	Over-DUI	DUI value is higher than alert value
27	Over EUI	EUI value is higher than alert value
28	Meter reset	The power meter is resetting parameters.
29	Phase rotation	Phase A and C for current are inversely connected

Specifications

9.1 Specifications

Model Name		DPM-C530A		
Electrical Characteristics	Measurement Accuracy	Current	±0.2%	
		Voltage	±0.5%	
		Power	±0.5%	
		Active Energy	IEC62053-22 Class 0.5S	
		Reactive Energy	±0.5%	
		Power Factor	±0.5%	
		Frequency	±0.5%	
	Measurement Input Characteristics	Wiring Method	1P2W, 1P3W, 3P3W, 3P4W	
		Measured Voltage	L-L: 35~690 V _{AC} L-N: 20~400 V _{AC}	
		Measured Current	1A/5A	
Frequency Range		45~70 Hz		
Power Supply		80~265 V _{AC} (Max. power consumption 4.6W); 100~300 V _{DC}		
Communication	RS- 485 Port		Baud rate 9600/19200/38400bps , MODBUS	
Mechanical Characteristics	IP Degree of Protection	Front Display	IP54	
		Meter Body	IP20	
Dimensions (W x H x D)			96*96*95.4 mm	
Environmental Conditions	Operating Temperature		-20 °C ~ +70 °C	
	Storage Temperature		-30 °C ~ +80 °C	
	Humidity Rating		~95% RH	
	Altitude		Below 2000 m	
Electromagnetic Compatibility	Electrostatic Discharge		IEC 61000-4-2	
	Immunity to Radiated Fields		IEC 61000-4-3	
	Immunity to Fast Transients		IEC 61000-4-4	
	Immunity to Impulse Waves		IEC 61000-4-5	
	Conducted Immunity		IEC 61000-4-6	
	Immunity to Voltage Dips		IEC 61000-4-11	
	Conducted and Radiated Emissions		FCC part 15 EN 55011 class A	
	Harmonics Emissions		IEC 61000-3-2	
	Flicker Emissions		IEC 61000-3-3	
Safety	Europe		CE, IEC61010	

Display	Display Type	White backlit LCD
Instantaneous RMS values	Current	■
	Voltage	■
	Frequency	■
	Real, Reactive and Apparent Power	■
	Power Factor	■
Energy values	Active, Reactive and Apparent Energy	■
	Auto Metering	■
Demand values	Current	■
	Power	■
	Calculation Mode	Block
Power quality measurement	Current/Voltage Unbalance	■
	Total voltage Harmonic Distortion	■
	Total Current Harmonic Distortion	■
	Individual Current/Voltage Harmonic Distortion	2~31
Data recording	Max/Min of Instantaneous Values with Timestamp	voltage L-N, voltage L-L, current, frequency, active power, reactive power, apparent power, power factor, THD voltage L-L, THD voltage L-N, THD current, voltage L-L unbalance, voltage L-N unbalance, current unbalance
	Data Logs Type	Selectable 17 measurement values, voltage L-N, voltage L-L, current, neutral current, power factor, displacement power factor, active power, reactive power, apparent power, active energy delivered, active energy received, reactive energy delivered, reactive energy received, apparent energy delivered, apparent energy received, THD voltage, THD current
	Data Logs Recording Duration	Up to 2 months
	Alarms	29 types, Over-current, Under-current, Over neutral current, Over voltage L-L, Under voltage L-L, Over voltage L-N, Under voltage L-N, Over voltage unbalance, Over current unbalance, Over active power, Over reactive power, Over apparent power, under power factor(lead), under power factor(lag), under displacement power factor(lead), under displacement power factor(lag), Over current demand, Over active power demand, Over reactive power demand, Over apparent power demand, Over frequency, Under frequency, Over THD voltage, Over THD current, Phase loss, Meter reset, Phase rotation, Over DUI, Over EUI
	Alarms History	500
Communication	RS-485 Port	■
	Parameters Grouping	■
	MODBUS	MODBUS RTU/ASCII

9.2 Communication Specifications

Communication Specifications	
Max. Distance of Communication	1200 m
Max. Number of Connected Stations	32
Communication Protocols	MODBUS RTU / ASCII
Functional Code	03, 06, 10, FE
Baud Rate	9600, 19200, 38400
Data Bit	7, 8
Parity	None, Odd, Even
Stop Bit	1, 2

9.3 MODBUS Communication

9.3.1 Format of MODBUS Communication:

Function Code	MODBUS Name	Description
0x03	Read Holding Registers	Read the contents of read location
0x06	Write Single Holding Registers	Preset the contents of written location
0x10	Write Multiple Holding Registers	Preset the contents of written location
0xFE	Read Data Log/THD/alarm Log	Read the contents of data log/THD/alarm log

*Note: When the protocol is MODBUS RTU, the maximum address to be gathered with a single MODBUS block read is 125 for function code 0x03, and the maximum address is 123 for function code 0x10. When the protocol is MODBUS ASCII, the maximum address to be gathered with a single MODBUS block read is 60 for function code 0x03, and the maximum address is 59 for function code 0x10. The function code 0xFE can be used only when the protocol is MODBUS RTU.

9.3.2 MODBUS Communication Protocols

(1) MODBUS RTU mode is adopted with MODBUS Master sending out the Request, in which the Function Code uses 0x03 to request response from Slave to correspond to values in MODBUS address. In Response, MODBUS Slave responds to the values of MODBUS address in the Master request. The packet format of IEEE754 is used for the address of floating point numbers that corresponds to the register values found in table 7.1, using 2's complement packet format. The format are as follows:

Low Word		High Word	
High Byte	Low Byte	High Byte	Low Byte

The packet formats for the address of integers that corresponds to the register values found in table 7.1 are shown in the example below.

Read :

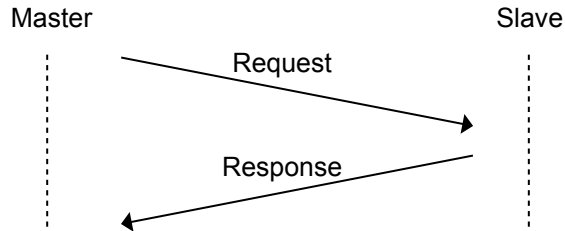

Request

Slave Address	1 ~ 255
Function Code	03h
Start Address (High)	00h ~ FFh
Start Address (Low)	00h ~ FFh
Number of Point (High)	00h
Number of Point (Low)	00h ~ FFh
Error Check (Low)	CRC
Error Check (High)	CRC

Response

Slave Address	1 ~ 255
Function Code	03h
Byte Count	00h ~ FFh
Data (High)	00h
Data (Low)	00h ~ FFh
Error Check (Low)	CRC
Error Check (High)	CRC

Write :

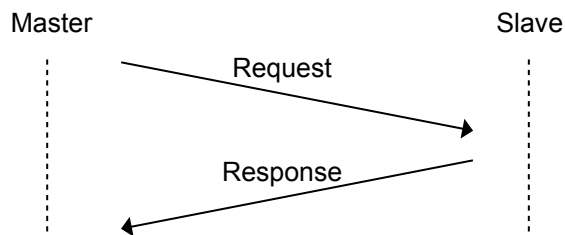

Request

Slave Address	1 ~ 255
Function Code	06h
Start Address (High)	00h ~ FFh
Start Address (Low)	00h ~ FFh
Number of Point (High)	00h
Number of Point (Low)	00h ~ FFh
Error Check (Low)	CRC
Error Check (High)	CRC

Response

Slave Address	1 ~ 255
Function Code	06h
Start Address (High)	00h ~ FFh
Start Address (Low)	00h ~ FFh
Number of Point (High)	00h
Number of Point (Low)	00h ~ FFh
Error Check (Low)	CRC
Error Check (High)	CRC

Example:

For MODBUS Master, such as PLC or data collector, it uses MODBUS protocol to get the value of CT setting (register address 0x000E) on the power meter (MODBUS Slave) (Slave address 0x1). The register value is 1000.

The packet format for Request sent out by MODBUS Master (PLC or data collector) is as follows:

Master Request

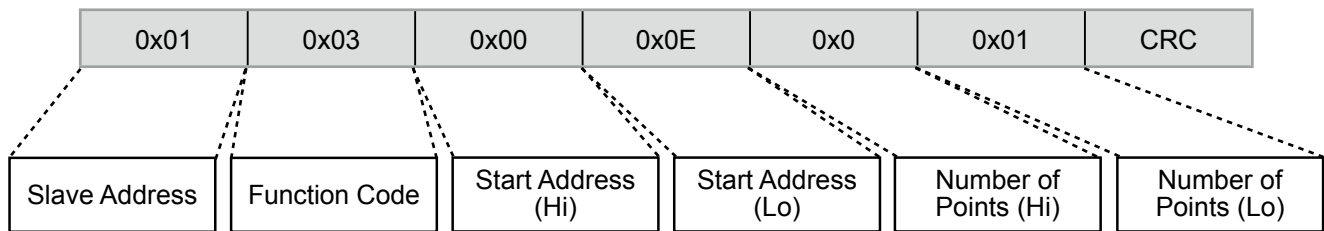

The packet format for Response responded by MODBUS Slave (power meter) is as follows:

Slave Response

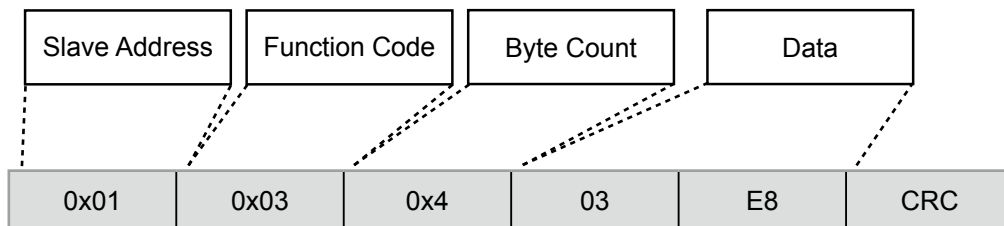

After receiving response from the power meter, MODBUS Master acquires the value of currents from the primary-side current transformer (register address 0x000E), which is 1000.

Should MODBUS Slave (power meter) receive an abnormal Request, the format of the abnormal packet responded is as follows. Refer to Chapter 9 for the abnormal codes.

Slave Response

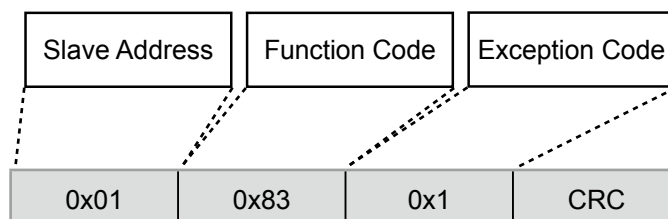

9.3.3 Packet format for MODBUS function code 0xFE

The function code 0xFE can be used only when the protocol is MODBUS RTU. It is for reading the data of Data Log, individual harmonics from 2nd through 31st, and alarm log. The packet format of 0xFE is similar to that of MODBUS RTU. The MODBUS Master send out requests with function code 0xFE asking the Slave to response with corresponding values in a MODBUS address. MODBUS Slave then responses Master with the corresponding values in Response.

Example 1(Data Log):

If the MODBUS Master (a PLC or data collector) reads recorded data from the meter with function code 0xFE in MODBUS address 0x800, the Request packet format is as below (it is the same as MODBUS RTU, but the Number of Points must be 1) :

Master Request

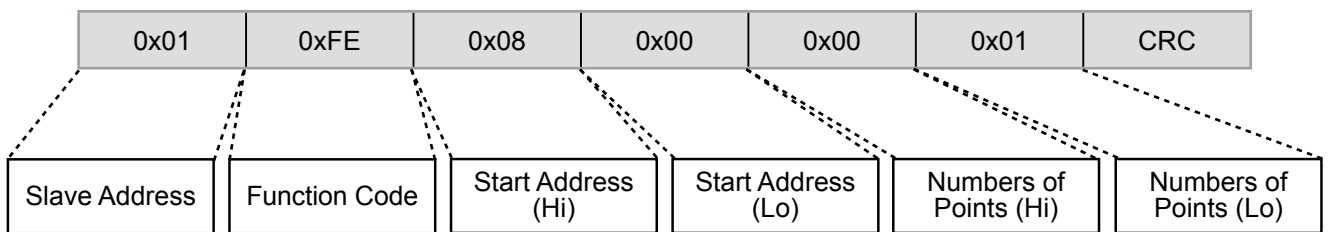

The Response packet format of the MODBUS slave (Power Meter) is as below (the part before Byte Count is the same as MODBUS RTU. The Data Log of 3 intervals is data of 3 continuous recording intervals. The order is as below. If N parameters are selected, the length of data is totally $3*(6+4N)$ bytes.)

Slave Response

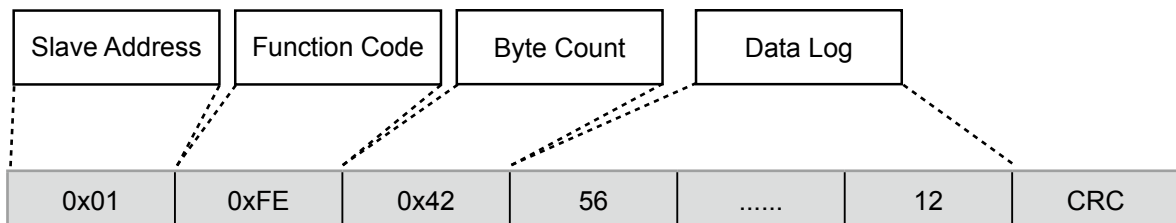

Data Log of 3 intervals - the order of one of the intervals:

Sequential order	item	Data size(byte)	Sequential order	
1	Year	1		
2	Month	1		
3	Day	1		
4	Hour	1		
5	Minute	1		
6	Second	1		
7	Selected Parameter1	4	Low word	High byte
				Low byte
			High word	High byte
				Low byte
8	Selected Parameter2	4	Low word	High byte
				Low byte
			High word	High byte
				Low byte
⋮	⋮	⋮	⋮	⋮
N	Selected Parameter N	4	Low word	High byte
				Low byte
			High word	High byte
				Low byte

Example 2 (individual harmonics):

If the MODBUS Master (a PLC or data collector) reads recorded data from the meter with function code 0xFE in MODBUS address 0x700, the Request packet format is as below (it is the same as MODBUS RTU, but the Number of Points must be 1)

Master Request

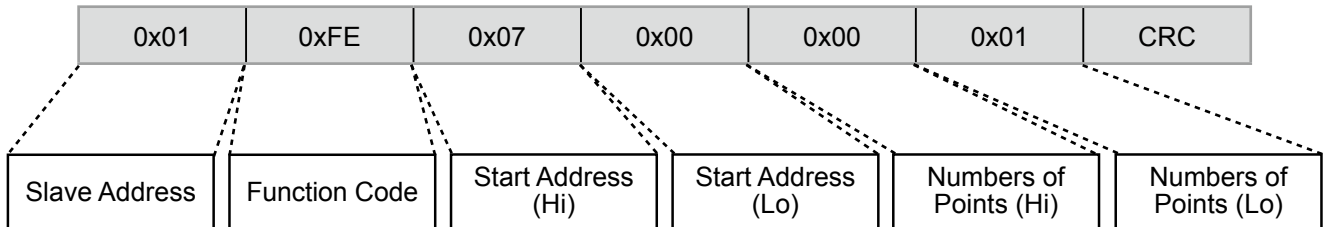

The Response packet format of the MODBUS slave is as below:

Slave Response

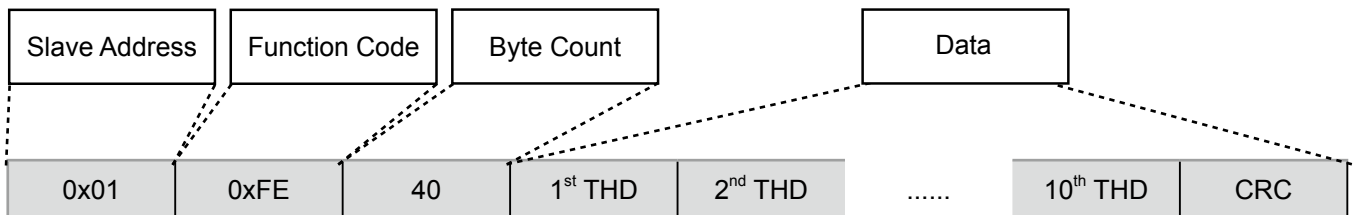

Appendix

Appendix 1: Selecting Accessories

Current Transformer:

Should input current exceed rated current tolerated by the meter specifications, the power meter needs to be used together with a current transformer (CT).

Users can select a suitable CT according to the table below.

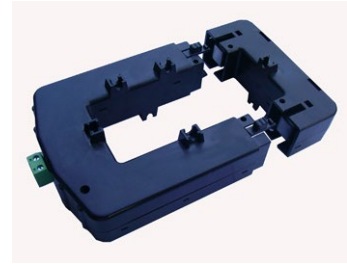

Model	Primary Current (A)	Secondary Current (A)	Burden (VA)	Accuracy (%)	Size (mm)	
					Outer frame	Inner frame
DCT-S301C	100A	5A	1.5VA	1.0%	Outer frame	115*89*51
					Inner frame	32*21*32
DCT-S211C	200A	5A	1.0VA	0.5%	Outer frame	115*89*51
					Inner frame	32*21*32
DCT-S221C	300A	5A	1.5VA	0.5%	Outer frame	115*89*51
					Inner frame	32*21*32
DCT-S231C	400A	5A	2.5VA	0.5%	Outer frame	115*89*51
					Inner frame	32*21*32
DCT-S241C	500A	5A	2.5VA	0.5%	Outer frame	145*116*51
					Inner frame	80*50*32
DCT-S251C	600A	5A	2.5VA	0.5%	Outer frame	145*116*51
					Inner frame	80*50*32
DCT-S261C	750A	5A	3VA	0.5%	Outer frame	145*116*51
					Inner frame	80*50*32
DCT-S271C	1000A	5A	5VA	0.5%	Outer frame	145*116*51
					Inner frame	80*50*32
DCT-S281C	1500A	5A	7.5VA	0.5%	Outer frame	196*146*51
					Inner frame	122*80*32
DCT-S291C	2000A	5A	10VA	0.5%	Outer frame	250*186*51.4
					Inner frame	160.5*81*32
DCT-S2A1C	2500A	5A	15VA	0.5%	Outer frame	250*186*51.4
					Inner frame	160.5*81*32
DCT-S2B1C	3000A	5A	20VA	0.5%	Outer frame	250*186*51.4
					Inner frame	160.5*81*32

*All models are not UL-certified.

Notes on selecting a current transformer

1. For the current transformer, the model with a closer maximal current on the primary side should be selected according to the maximal current actually input.
For example: When the maximal current input is 700 A, DCT-S261C can be selected.
2. Wire over-length on the secondary side of the current transformer causes decrease in accuracy.



Smarter. Greener. Together.

Industrial Automation Headquarters

Delta Electronics, Inc.

Taoyuan Technology Center
No.18, Xinglong Rd., Taoyuan Dist.,
Taoyuan City 33068, Taiwan
TEL: 886-3-362-6301 / FAX: 886-3-371-6301

Asia

Delta Electronics (Jiangsu) Ltd.

Wujiang Plant 3
1688 Jiangxing East Road,
Wujiang Economic Development Zone
Wujiang City, Jiang Su Province,
People's Republic of China (Post code: 215200)
TEL: 86-512-6340-3008 / FAX: 86-769-6340-7290

Delta Greentech (China) Co., Ltd.

238 Min-Xia Road, Pudong District,
ShangHai, P.R.C.
Post code : 201209
TEL: 86-21-58635678 / FAX: 86-21-58630003

Delta Electronics (Japan), Inc.

Tokyo Office
2-1-14 Minato-ku Shibadaimon,
Tokyo 105-0012, Japan
TEL: 81-3-5733-1111 / FAX: 81-3-5733-1211

Delta Electronics (Korea), Inc.

1511, Byucksan Digital Valley 6-cha, Gasan-dong,
Geumcheon-gu, Seoul, Korea, 153-704
TEL: 82-2-515-5303 / FAX: 82-2-515-5302

Delta Electronics Int'l (S) Pte Ltd

4 Kaki Bukit Ave 1, #05-05, Singapore 417939
TEL: 65-6747-5155 / FAX: 65-6744-9228

Delta Electronics (India) Pvt. Ltd.

Plot No 43 Sector 35, HSIIDC
Gurgaon, PIN 122001, Haryana, India
TEL : 91-124-4874900 / FAX : 91-124-4874945

Americas

Delta Products Corporation (USA)

Raleigh Office
P.O. Box 12173, 5101 Davis Drive,
Research Triangle Park, NC 27709, U.S.A.
TEL: 1-919-767-3800 / FAX: 1-919-767-8080

Delta Greentech (Brasil) S.A

Sao Paulo Office
Rua Itapeva, 26 - 3° andar Edifício Itapeva One-Bela Vista
01332-000-São Paulo-SP-Brazil
TEL: +55 11 3568-3855 / FAX: +55 11 3568-3865

Europe

Deltronics (The Netherlands) B.V.

Eindhoven Office
De Witbogt 20, 5652 AG Eindhoven, The Netherlands
TEL: 31-40-2592850 / FAX: 31-40-2592851

*We reserve the right to change the information in this catalogue without prior notice.