

# CliQ II Redundancy Modules

## 20A / DRR-20□, 40A / DRR-40□



### Highlights & Features

- Wide input and output range of 22-60Vdc
- Very wide operating temperature from -40°C to +80°C
- Built-in 2 channel DC OK signal and alarm relay contact
- Support N+1 Redundancy connection
- Conformal coating on PCBA to protect against chemical and dust pollutants
- Hazardous Locations approval to ATEX and Class I, Div 2 (DRR-20A and DRR-40A)

### Safety Standards



CB Certified for worldwide use

<b>Model Number:</b>	DRR-20□, DRR-40□
<b>Unit Weight:</b>	0.38 kg (0.84 lb), 0.52 kg (1.15 lb)
<b>Dimensions (L x W x D):</b>	121 x 50 x 122.1 mm (4.76 x 1.97 x 4.81 inch)

### General Description

Delta's CliQ II redundancy modules offer a variable input and output voltage from 22Vdc to 60Vdc. The DRR-20□ and DRR-40□ can operate over a wide temperature range of -40°C to +80°C. The state-of-the-art design is made to withstand harsh industrial environments. The rugged, compact aluminium case is shock and vibration resistant according to IEC 60068-2 standard. Due to the wide input and output voltage range from 22Vdc to 60Vdc, the redundancy modules are able to support power supply in parallel operation. These modules also have an alarm relay contact as an indicator.

### Model Information

#### CliQ II Redundancy Module

Model Number	Input Voltage Range	Rated Output Voltage	Rated Output Current
DRR-20□	22-60Vdc	$V_{in}-0.65V$ (typ.)	20.0A
DRR-40□	22-60Vdc	$V_{in}-0.65V$ (typ.)	40.0A

### Model Numbering

DR	R -	XXA	□
DIN Rail	Redundancy Module	Output Current 20 - 20A 40 - 40A	A - Metal Case, with Class I, Div N - Metal Case, without Class I, Div 2

# CliQ II Redundancy Modules

## 20A / DRR-20□, 40A / DRR-40□

### Specifications

#### Input Ratings / Characteristics

Nominal Input Voltage		24Vdc and 48Vdc
Input Voltage Range		22-60Vdc
Input Current	DRR-20□	20A Max (1+1 Redundancy) = Nominal 2 x 12.5A (N+1 Redundancy) = Nominal 2 x 10A (Single Use) = Nominal 20A
	DRR-40□	40A Max (1+1 Redundancy) = Nominal 2 x 25A (N+1 Redundancy) = Nominal 2 x 20A (Single Use) = Nominal 40A
Efficiency		> 97.0% typ.
Input Voltage Alarm / Relay Contacts*	DRR-20□	24V System: Both $V_{in1}$ & $V_{in2}$ > 18V $\pm$ 5% or < 30V Max
	DRR-40□	48V System: Both $V_{in1}$ & $V_{in2}$ > 36V $\pm$ 5% or < 60V Max

\*The LED will turn on when the  $V_{in1}$  &  $V_{in2}$  > 18V  $\pm$  5% (for 24V system) or > 36V  $\pm$  5% (for 48V system) and not more than 30V (for 24V system) or not more than 60V (for 48V system). The relay contacts will be closed. If  $V_{in1}$  &  $V_{in2}$  are under or over this range, the LED will turn off.

#### Output Ratings / Characteristics

Nominal Output Voltage Range		$V_{in}$ -0.65V (typ.)
Output Current	DRR-20□	20A Max
	DRR-40□	40A Max
Voltage Drop ( $V_{in}$ - $V_{out}$ )		0.65V typ.
Output Current		20A Max

### Mechanical

Case Cover / Chassis		Aluminium
Dimensions (L x W x D)		121 x 50 x 122.1 mm (4.76 x 1.97 x 4.81 inch)
Unit Weight	DRR-20□	0.38 kg (0.84 lb)
	DRR-40□	0.52 kg (1.15 lb)
LED Indicators		Green LED DC OK: $V_{in1}$ and $V_{in2}$
Cooling System		Convection
Terminal	DRR-20□	Input: 3 Pins (Rated 300V/30A) Output: 4 Pin (Rated 300V/30A)
	DRR-40□	Input: 5 Pins (Rated 300V/30A) Output: 5 Pin (Rated 300V/30A)
Wire	Input / Output	AWG 12-10
Mounting Rail		Standard TS35 DIN Rail in accordance with EN 60715
Noise (1 Meter from power supply)		Sound Pressure Level (SPL) < 40dBA

# CliQ II Redundancy Modules

20A / DRR-20□, 40A / DRR-40□

## Environment

Surrounding Air Temperature	Operating	-40°C to +80°C
	Storage	-40°C to +85°C
Power De-rating	Vertical Mounting	> 50°C de-rate power by 2.5% / °C
	Horizontal Mounting	> 50°C de-rate power by 2.5% / °C
Operating Humidity	5 to 95% RH (Non-Condensing)	
Operating Altitude	0 to 2,500 Meters (8,200 ft.)	
Shock Test	Non-Operating	IEC 60068-2-27, 30G (300m/S <sup>2</sup> ) for a duration of 18ms, 1 time per direction, 2 times in total
Vibration	Non-Operating	IEC 60068-2-6, 10Hz to 500Hz @ 30m/S <sup>2</sup> (3G peak); 60 min per axis for all X, Y, Z direction
Over Voltage Category	III	According to IEC/EN 62477-1 / EN 60204-1 (clearance and creepage distances) and IEC 62103 (safety part)
Pollution Degree	2	

## Protections

Overload / Overcurrent*	DRR-20□	< 25A, No Damage
	DRR-40□	< 50A, No Damage
Short Circuit	DRR-20□	< 25A, No Damage
	DRR-40□	< 50A, No Damage
Degree of Protection	IP20	
Protection Against Shock	Class III with PE** connection	

\*The overload condition must be controlled by the PSUs in parallel. The limit of input current should not be more than 25A (for 20A module) or not more than 50A (for 40A module).

\*\*PE: Primary Earth

## Reliability Data

MTBF	> 800,000 hrs. as per Telcordia SR-332 I/P: 24Vdc and 48Vdc, O/P: 100% load, Ta: 25°C
Expected Cap Life Time	10 years (Standby Mode @ 40°C)

# CliQ II Redundancy Modules

## 20A / DRR-20□, 40A / DRR-40□

### Safety Standards / Directives

Electrical Equipment in Power Installations		IEC/EN 62477-1 / IEC 62103
Electrical Safety	SIQ Bauart	EN 60950-1
	UL/cUL recognized	UL 60950-1 and CSA C22.2 No. 60950-1
	CB scheme	IEC 60950-1
Industrial Control Equipment	UL/cUL recognized	UL 508 and CSA C22.2 No. 107.1-01
Hazardous Location / ATEX (For DRR-20A and DRR-40A)	Hazardous Location	cCSAus to CSA C22.2 No. 213-M1987, ANSI / ISA 12.12.01:2007 [Class I, Division 2, Group A, B, C, D T4, Ta= -40°C to +80°C (> +50°C derating)]
	ATEX	EN 60079-0:2009, EN 60079-15:2010 [Ex II 3G Ex nA nC IIC T4 Gc, Ta= -40°C to +80°C (> +50°C derating)]
Ex II 3G ATEX 2014/34/EU (For DRR-20A and DRR-40A)		Certificate No. EPS 12 ATEX 1 491 X
CE		In conformance with EMC Directive 2014/30/EU and Low Voltage Directive 2014/35/EU  For DRR-20A and DRR-40A: In conformance with Equipment for explosive atmospheres (ATEX) directive 2014/34/EU
Material and Parts		RoHS Directive 2011/65/EU Compliant (EN 50581)
Galvanic Isolation	Input & Output / PE	1.5kVac

### EMC

Emissions (CE & RE)		CISPR 32, EN 55032, EN 55011, FCC Title 47: Class B
Immunity		EN 55024, EN 61000-6-2
Electrostatic Discharge	IEC 61000-4-2	Level 4 Criteria A <sup>1)</sup> Air Discharge: 15kV Contact Discharge: 8kV
Radiated Field	IEC 61000-4-3	Level 3 Criteria A <sup>1)</sup> 80MHz-1GHz, 10V/M, 80% modulation (1KHz)
Electrical Fast Transient / Burst	IEC 61000-4-4	Level 3 Criteria A <sup>1)</sup> 2kV
Surge	IEC 61000-4-5	Level 3 Criteria A <sup>1)</sup> Common Mode <sup>2)</sup> : 2kV Differential Mode <sup>3)</sup> : 1kV
Conducted	IEC 61000-4-6	Level 3 Criteria A <sup>1)</sup> 150kHz-80MHz, 10Vrms
Power Frequency Magnetic Fields	IEC 61000-4-8	Criteria A <sup>1)</sup> 10A/Meter
Voltage Dips and Interruptions	IEC 61000-4-11	Level 3 Criteria A <sup>1)</sup> Additional 100% dip; 1 cycle (20ms); No Damage
Low Energy Pulse Test (Ring Wave)	IEC 61000-4-12	Level 3 Criteria A <sup>1)</sup> Common Mode <sup>2)</sup> : 2kV Differential Mode <sup>3)</sup> : 1kV

Note: Product intended to be used as Apparatus with AC-DC Power Supply, EMC compliance to be verified in correspondence to the connected units.

- 1) Criteria A: Normal performance within the specification limits  
 2) Asymmetrical: Common (Line to earth)  
 3) Symmetrical: Differential mode (Line to line)

# CliQ II Redundancy Modules

20A / DRR-20□, 40A / DRR-40□

## Block Diagram

### DRR-20□

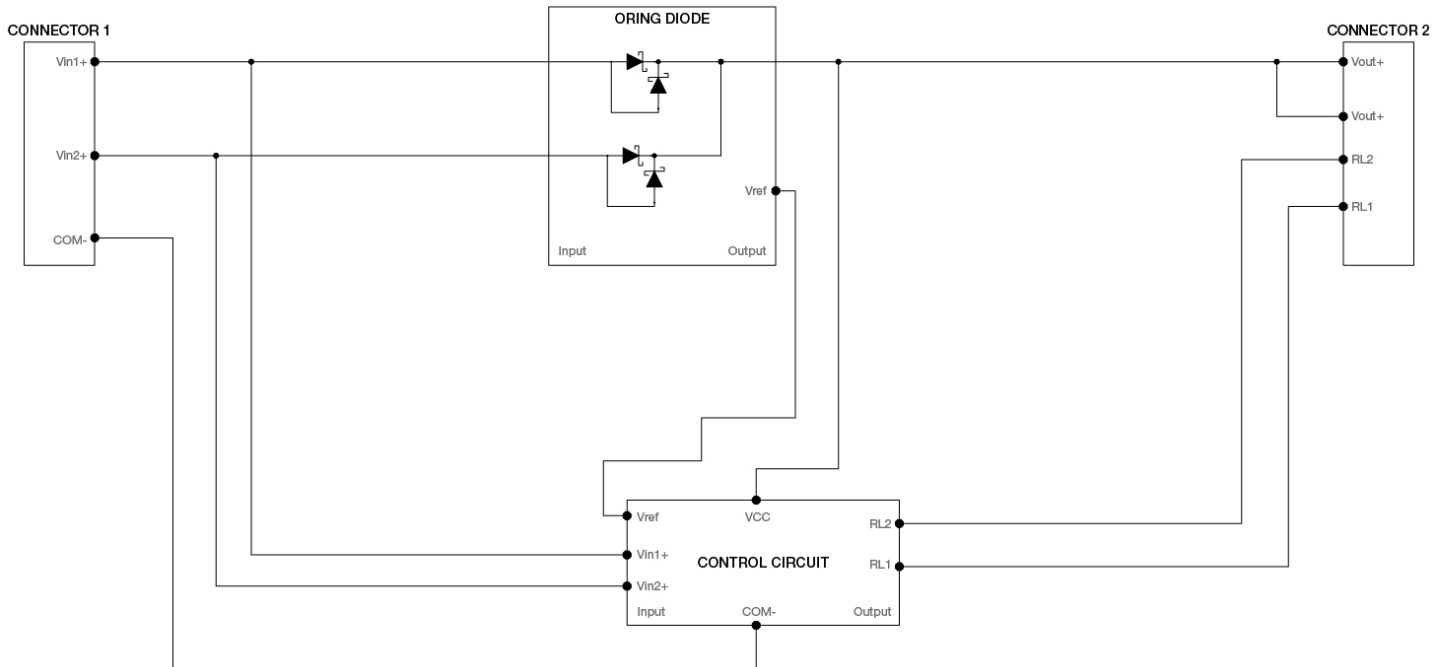

### DRR-40□

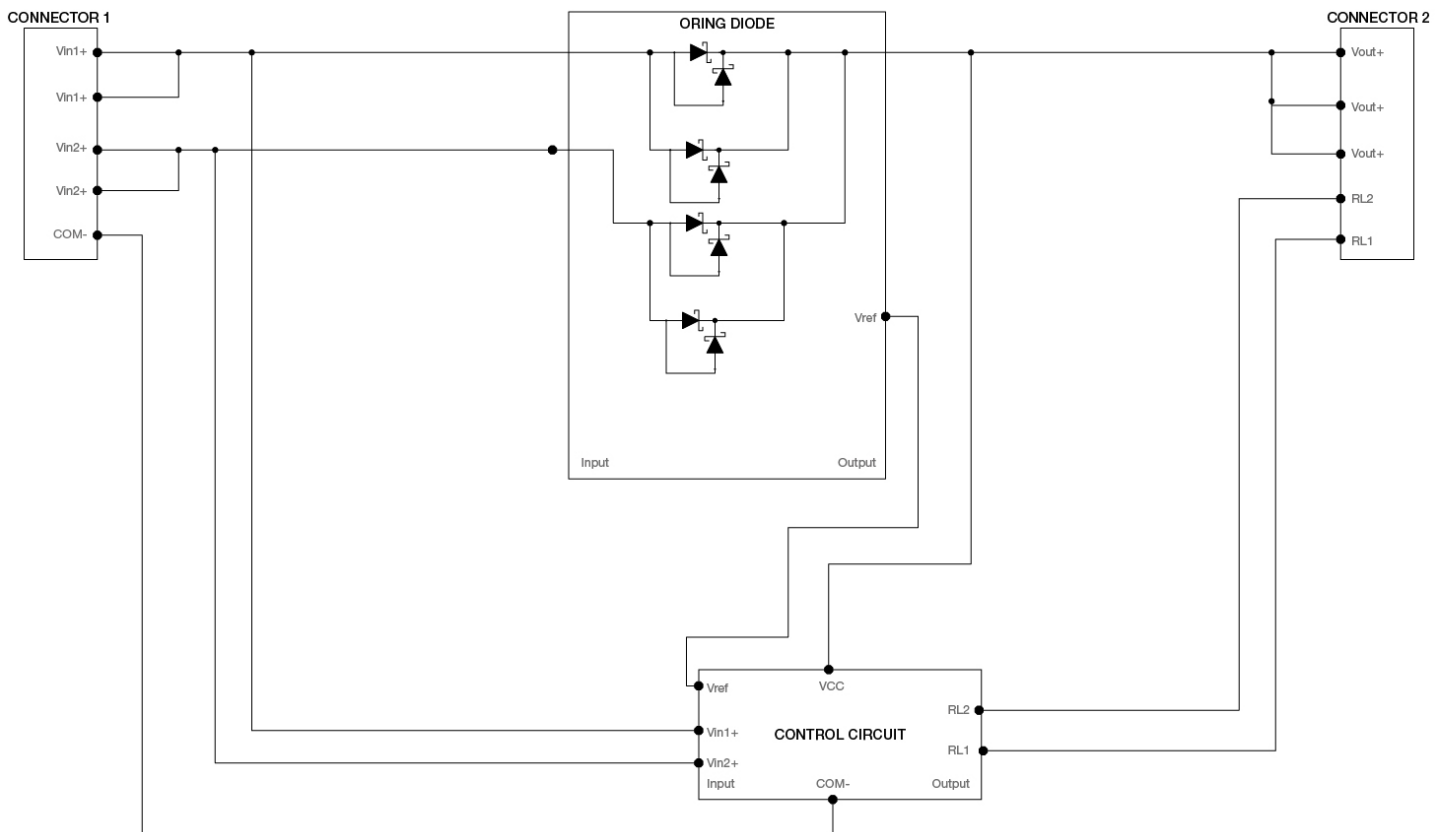

# CliQ II Redundancy Modules

20A / DRR-20□, 40A / DRR-40□

## Device Description

DRR-20□

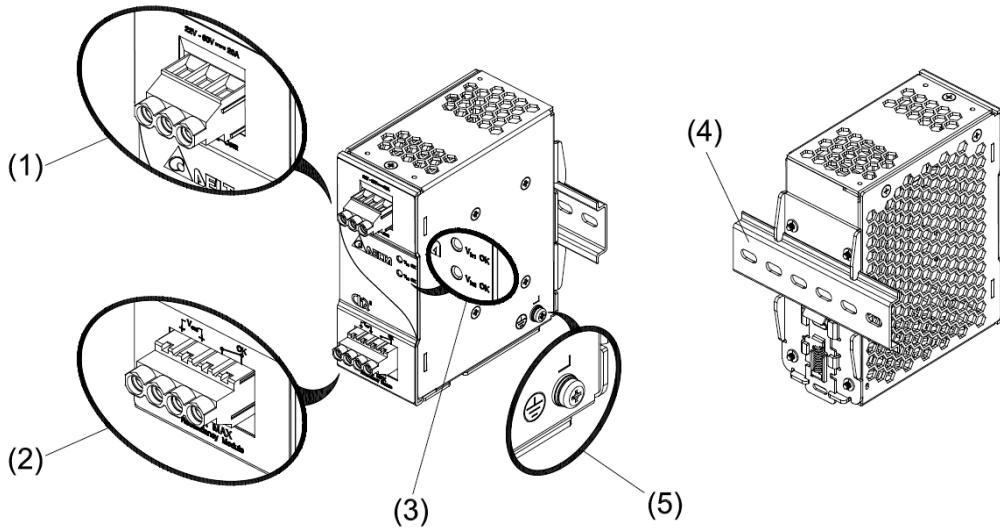

DRR-40□

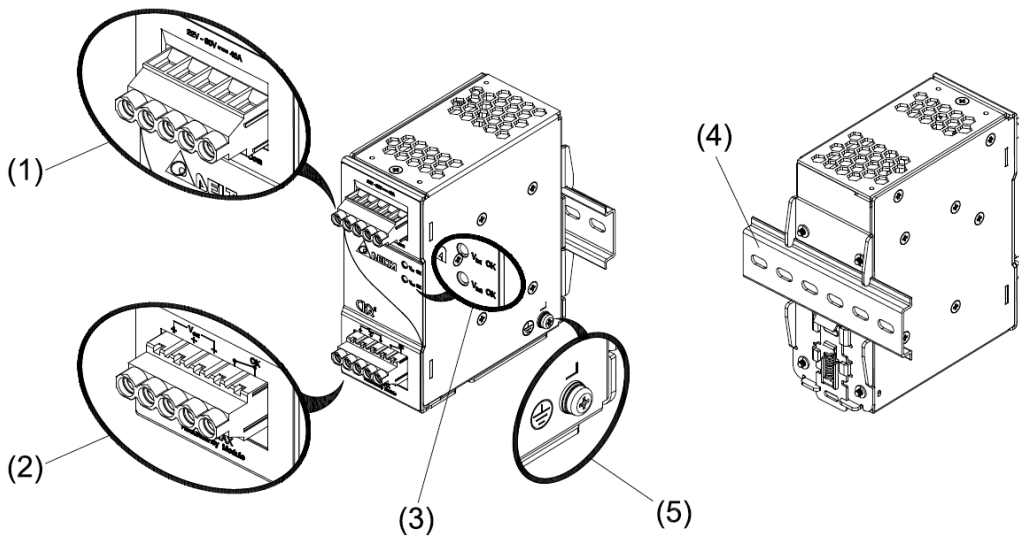

- 1) Input terminal block connector
- 2) Output terminal block connector
- 3) LED indicator of  $V_{in1}$  &  $V_{in2}$
- 4) Universal mounting rail system
- 5) Earth connection

# CliQ II Redundancy Modules

20A / DRR-20□, 40A / DRR-40□

## Dimensions

DRR-20□

L x W x D: 121 x 50 x 122.1 mm (4.76 x 1.97 x 4.81 inch)

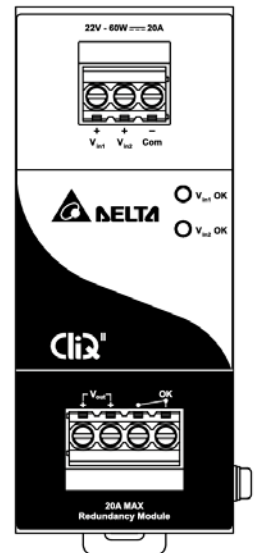
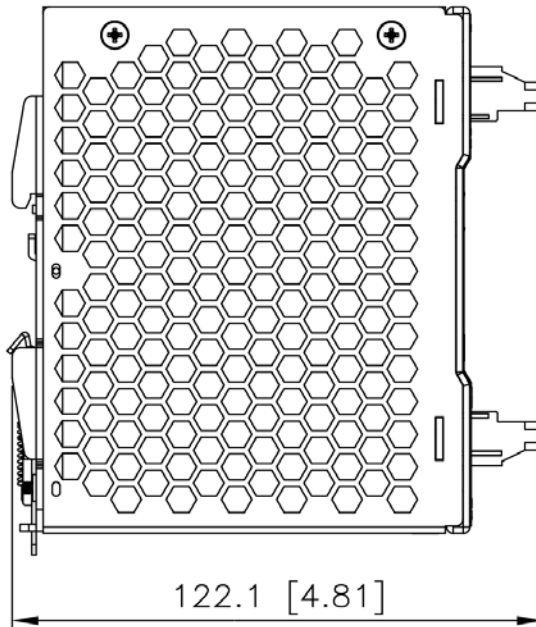
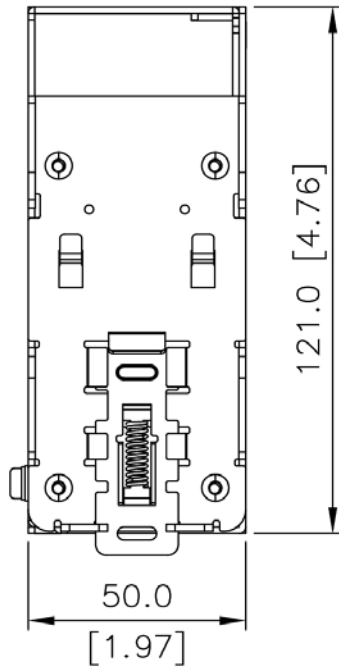

DRR-40□

L x W x D: 121 x 50 x 122.1 mm (4.76 x 1.97 x 4.81 inch)

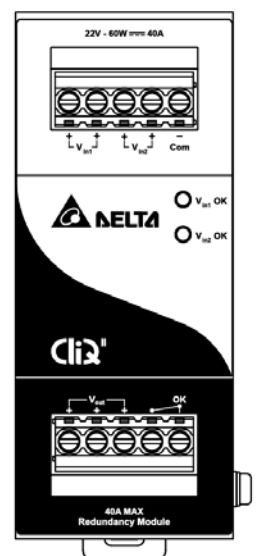
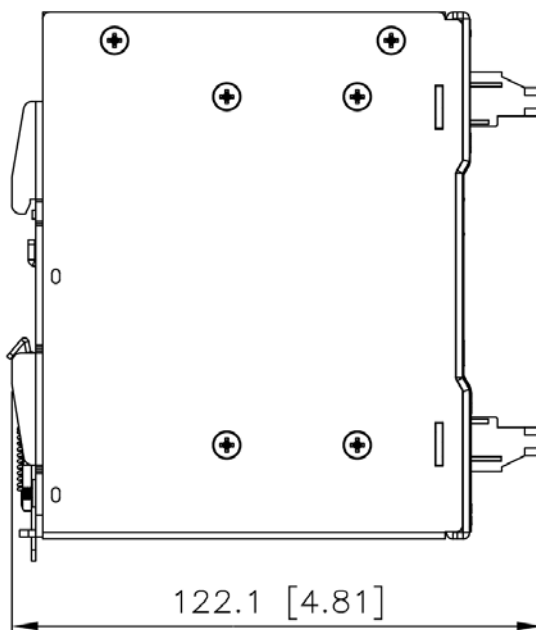
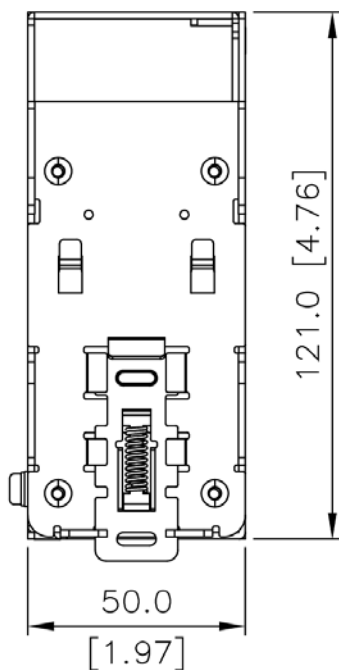

# CliQ II Redundancy Modules

## 20A / DRR-20□, 40A / DRR-40□

### Engineering Data

#### Output Load De-rating VS Surrounding Air Temperature

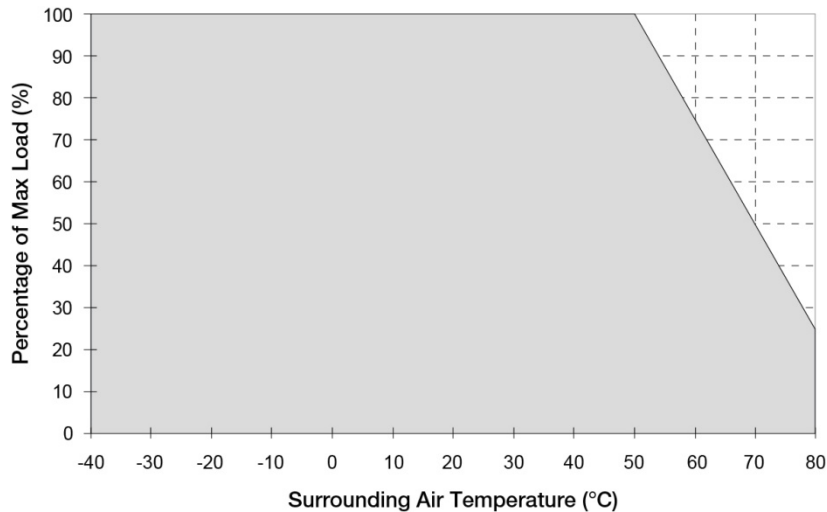

**Fig. 1 De-rating for Vertical and Horizontal Mounting Orientation**  
 > 50°C de-rate power by 2.5% / °C

#### Note

1. The unit may degrade, or be damaged, when it is continuously used outside the shaded region, refer to the graph shown in Fig. 1.
2. If the output capacity is not reduced when the surrounding air temperature exceeds its specification as defined on Page 3 under “Environment”, the device may have some thermal stress problem and the ORing Diodes may become too hot.
3. In order for the device to function in the manner intended, it is also necessary to keep a safety distance as recommended in the safety instructions while the device is in operation.
4. Depending on the surrounding air temperature and output load delivered by the power supply, the device can be very hot!
5. If the device has to be mounted in any other orientation, please contact [info@deltapsu.com](mailto:info@deltapsu.com) for more details.

### Assembly & Installation

The unit can be mounted on 35mm (1.38 inch) DIN rails in accordance with EN 60715. The device should be installed with input terminal block at the top.

Each device is delivered ready to install.

#### Mounting

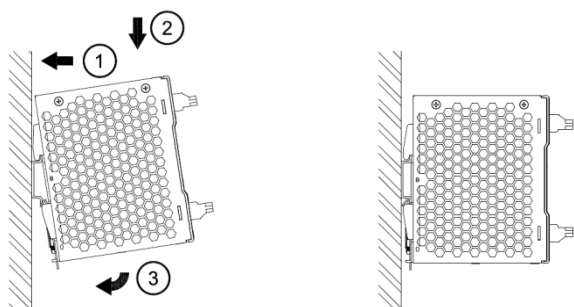
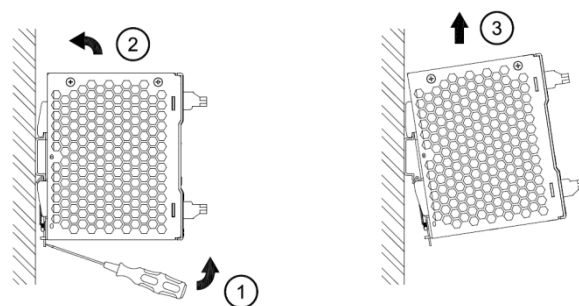

**Fig. 2.1 Mounting**

Snap on the DIN rail as shown in Fig. 2.1:

1. Tilt the unit upwards and insert it onto the DIN rail.
2. Push downwards until stopped.
3. Press against the bottom front side for locking.
4. Shake the unit slightly to ensure that it is secured.

#### Dismounting



**Fig. 2.2 Dismounting**

To uninstall, pull or slide down the latch with screw driver as shown in Fig. 2.2. Then slide the unit in the opposite direction, release the latch and pull out the unit from the rail.

In accordance to EN 60950 / UL 50950, flexible cables require ferrules.

Use appropriate copper cables designed to sustain operating temperature of 60°C / 75°C or more to fulfill UL requirements.



# CliQ II Redundancy Modules

## 20A / DRR-20□, 40A / DRR-40□

### Safety Instructions

#### ■ Vertical Mounting

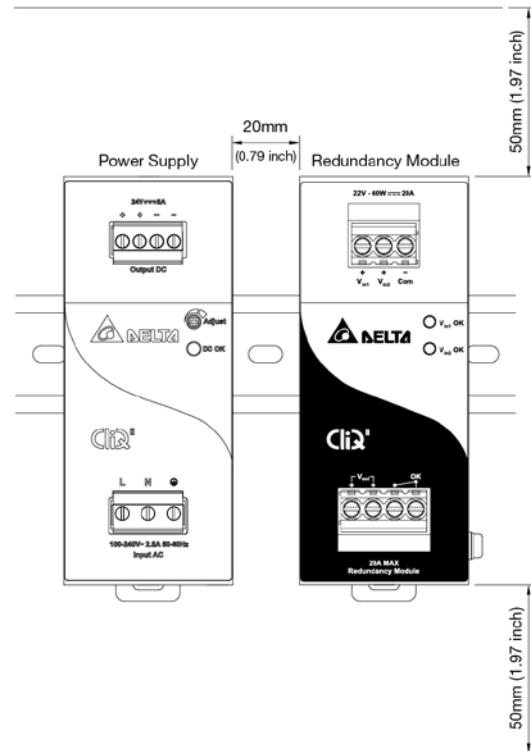

#### ■ Horizontal Mounting

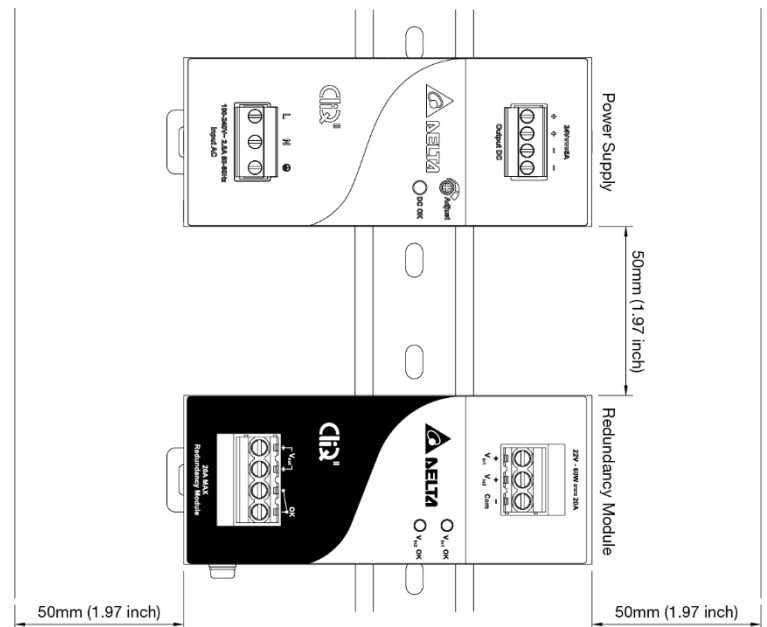

- ALWAYS switch mains of input power OFF before connecting and disconnecting the input voltage to the unit. If mains are not turned OFF, there is risk of explosion / severe damage.
- **To guarantee sufficient convection cooling, keep a distance of 50mm (1.97 inch) above and below the device as well as a lateral distance of 20mm (0.79 inch) to other units.**
- Note that the enclosure of the device can become very hot depending on the surrounding air temperature and load of the power supply. Risk of burns!
- The main power must be turned off before connecting or disconnecting wires to the terminals!
- DO NOT insert any objects into the unit.
- Hazardous voltages may be present for up to 5 minutes after the input mains voltage is disconnected. Do not touch the unit during this time.
- The supply of the unit shall comply with any isolated secondary circuit according to UL 508, Clause 32.

#### For DRR-20A and DRR-40A:

- The unit must be installed in an IP54 enclosure or cabinet in the final installation. The enclosure or cabinet must comply with EN60079-0 or EN60079-15.
- Warning: Explosion Hazard - Substitution of components may impair suitability for Class I, Division 2.
- Warning: Explosion Hazard - Do not disconnect equipment unless the power has been switched off or the area is known to be non-hazardous.

# CliQ II Redundancy Modules

20A / DRR-20□, 40A / DRR-40□

## Functions

### Typical Application Notes

Fig. 3.1 1+1 Redundancy

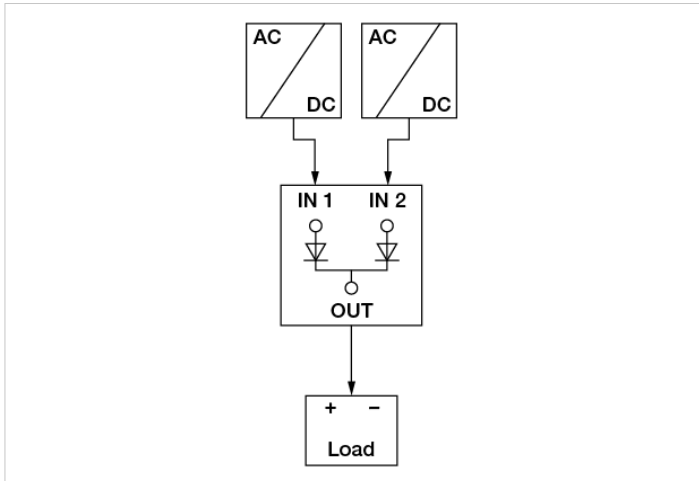

Using 1 more PSU as the redundant unit.

Fig. 3.2 Single Use

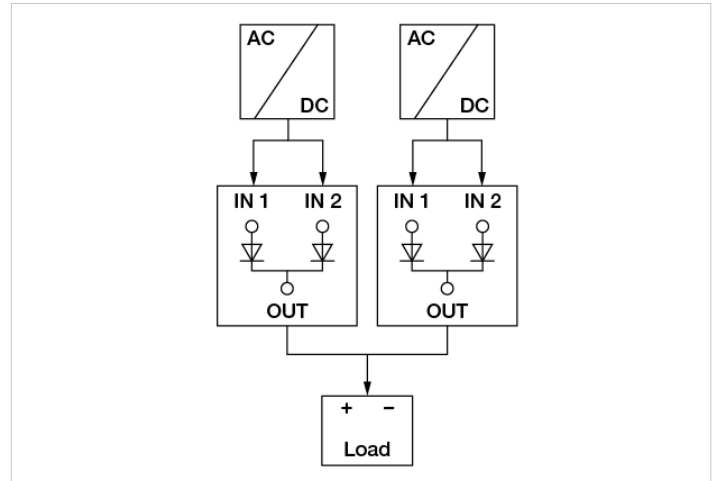

Using more PSUs as the redundant units to increase the reliability.

Fig. 3.3 N+1 Redundancy

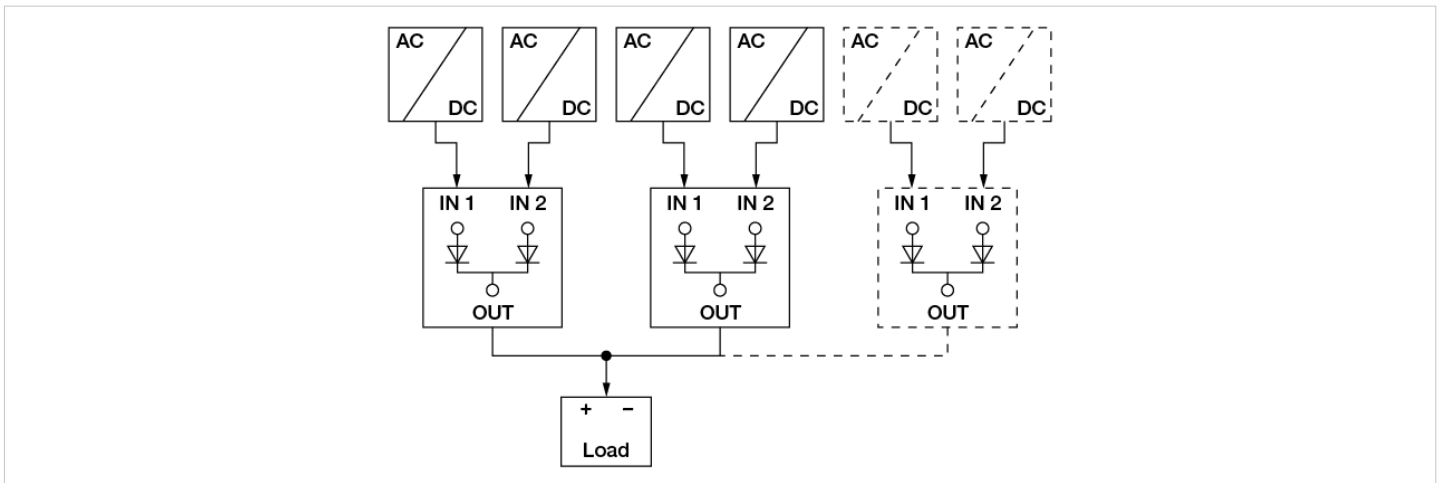

Connecting only one PSU to one DRR module to reduce the stress of the diodes and hence increase the reliability.

# CliQ II Redundancy Modules

## 20A / DRR-20□, 40A / DRR-40□

### Operating Mode

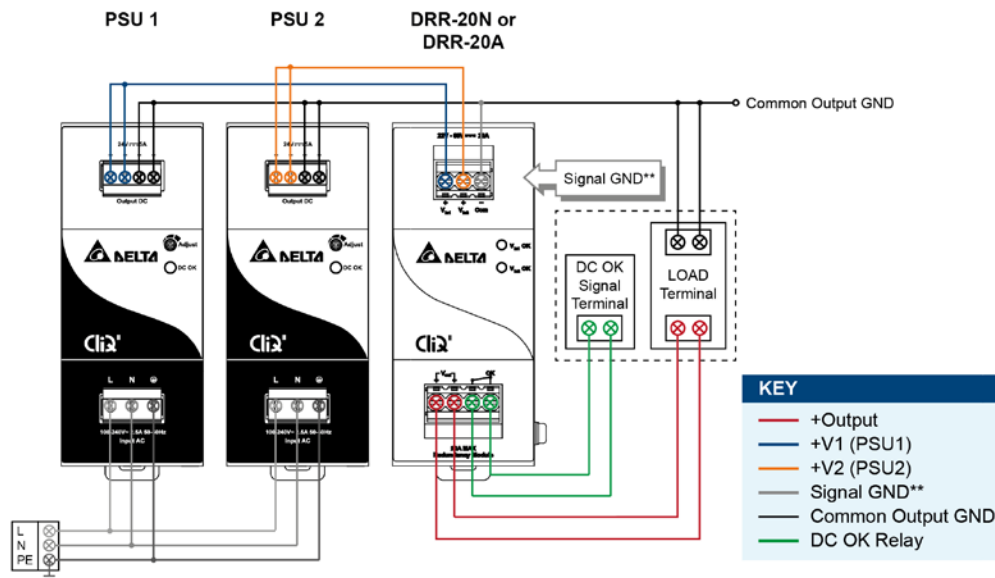

\*\*The Signal GND in the DRR module is for the built-in LED and DC OK signals. The Output GND terminals from the two PSU's do not need to be connected to the Signal GND terminal.

Fig. 4 Redundant / Parallel Operation Connection Diagram

#### ■ Redundant Operation

In order to ensure proper redundancy operation for the power supply unit (PSU), ensure that the output voltage difference between the two units is kept at 0.45–0.50V for 24V supplies. Follow simple steps given below to verify:

##### Step 1.

Measure output voltage of PSU 1 and PSU 2. If PSU 1 is the master unit, then  $V_O$  of PSU 1 must be higher than PSU 2.

In order to set the output voltage, connect the power supply to 50% load and set the PSU 1 and PSU 2 output voltage.

##### Step 2.

Connect the right DRR module as per the system requirement to the power supply units PSU 1 and PSU 2 at  $V_{in 1}$  &  $V_{in 2}$  respectively.

##### Step 3.

Connect the system load from  $V_{out}$ . Please note that output voltage  $V_{out}$  from DRR module will be =  $V_O$  (output voltage of power supply) –  $V_{drop}^*$  (in DRR module).

#### ■ Parallel Operation

These DRR modules can also be used for Parallel function in order to increase the output power by N+1 (e.g. 2.5A + 2.5A = 5A or 2.5A + 2.5A + 2.5A = 7.5A) or current sharing, and thus increasing the power supply and system reliability. A good current sharing between two power supplies can be achieved by following simple steps as below (Refer to Fig. 4 for the Connection Diagram).

##### Step 1.

Set output load condition for both supplies at 50% and measure the output voltages.

##### Step 2.

Adjust output voltages to the same level or within  $\pm 25mV$  difference.

##### Step 3.

Connect PSU 1 and PSU 2 with the DRR module and measure at  $V_{in 1}$  &  $V_{in 2}$  to verify the voltage difference. Ensure the voltages are within  $\pm 25mV$ .

##### Step 4.

Output voltage from DRR module  $V_{out}$  will be =  $V_O$  (output voltage of power supply) –  $V_{drop}^*$  (in DRR module).

\* $V_{drop}$  Will vary from 0.60V to 0.90V (Typical 0.65V) depending on the load current and surrounding air temperature.

# CliQ II Redundancy Modules

## 20A / DRR-20□, 40A / DRR-40□

### Others

#### Delta RoHS Compliant



#### Restriction of the usage of hazardous substances

The European directive 2011/65/EU limits the maximum impurity level of homogeneous materials such as lead, mercury, cadmium, chrome, polybrominated flame retardants PBB and PBDE for the use in electrical and electronic equipment. RoHS is the abbreviation for "Restriction of the use of certain hazardous substances in electrical and electronic equipment".

This product conforms to this standard.

#### Conformal Coating

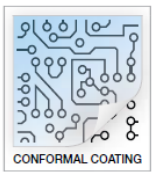

#### The Protective Coating Technology

Delta Electronics Group has designed the perfect dipping technique which penetrates everywhere including under device, and prevents leakage. The conformal coating dipping can be applied to PCBAs or circuit board. The coating preserves the performance of precision electronic primarily by preventing ionizable contaminants such as salt from reaching circuit nodes, where the material slumps around sharp edges. This can be a problem especially in highly conversing atmosphere.