

**Static Remover & Dust Remover Pulse Air-gun Ionizer
EC-G02**

MJE-ECG02 No.0048-24V

Thank you very much for purchasing Panasonic products. Read this Instruction Manual carefully and thoroughly for the correct and optimum use of this product. Kindly keep this manual in a convenient place for quick reference.

⚠ WARNING

- Never use this product with a device for personnel protection.
- In case of using devices for personnel protection, use products which meet laws or standards, such as OSHA, ANSI or IEC etc., for personnel protection applicable in each region or country.
- Do not use this product in places where there may be a danger of flammable or combustible items being present.
- Clean the discharge needle regularly (about once a week), otherwise optimum charge removal performance may not be obtained and fire or operating problems may occur.
- High voltages are applied to the discharge needle, so never touch the discharge needle while the power for the product is turned on, otherwise electric shocks may result.
- If this product is used in an airtight room, ozone emitted from this product may be detrimental. Therefore, in order for this product to be used in an airtight room, be sure to keep the room ventilated.
- Do not direct ionized air toward the face. Ozone may cause irritation to places such as the nose and throat.
- Do not look directly into the white LED spotlight. It may cause injury to the eyes.
- Since the tip of the discharge needle is sharp, take sufficient care in handling the discharge needle, or injuries may result.
- When air is not being supplied to this product, turn off the power in order to stop discharging from occurring. If discharging is allowed to continue while air is not being supplied, the ozone concentration will rise and accidents or operating problems may occur.
- This product includes precision components, so do not drop it or hit it against other objects. If this is not observed, accidents or problems with operation may occur.

1 OUTLINE

- This product is an air gun-type electrostatic charge removal and dust removal device which uses ion generation from corona discharges.
- This product is equipped with a pulse ionized air emission function for effectively removing dust and which can be replaced with normal continuous ionized air emission.
- It uses a built-in high-illumination white LED spotlight in order to illuminate the direction in which ionized air is being blown.

2 PART DESCRIPTION

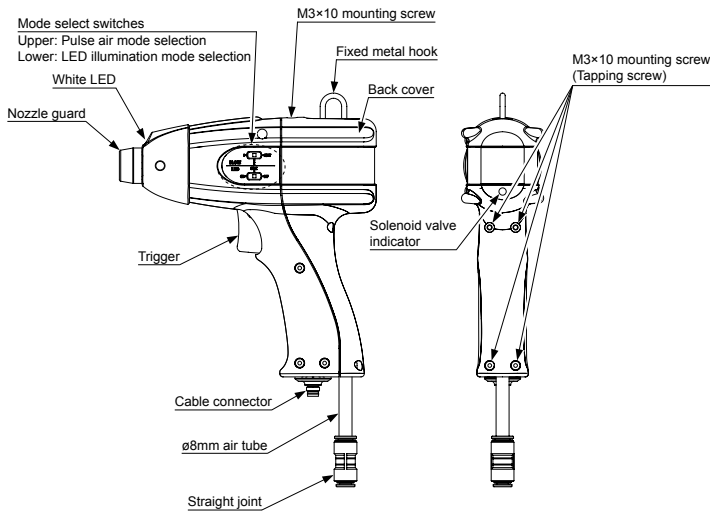

3 I/O circuit DIAGRAM

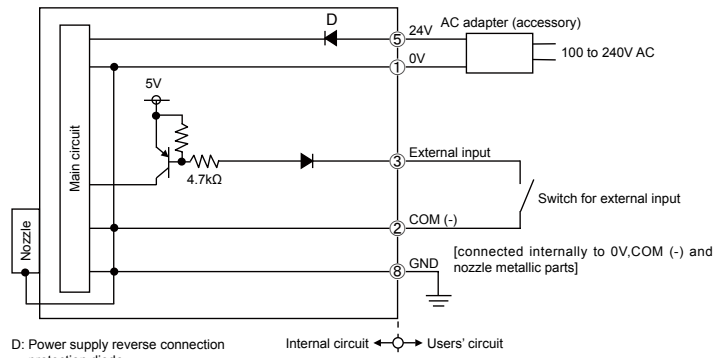

• Pin layout for AC adapter power supply connector

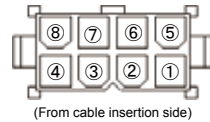

• Terminal block diagram

Terminal No.	Terminal name
1	0V
2	COM (-)
3	External input
4	N.C. (not used)
5	24V
6	N.C. (not used)
7	N.C. (not used)
8	GND

- 1 and 5 are connected to the AC adapter.
- Use the accessory connector wiring terminal to connect external input or GND.

• When using external input

When using external input, ionized air discharging can be carried out using the same ON/OFF operations as trigger input.

Note: The COM (-) terminal which uses external input is connected internally to 0V, the GND terminal and the nozzle metallic parts. If external input ON/OFF switching is carried out using an external control device instead of an independent mechanical-type switch, or if the 0V potential of the external control device and the grounding potential of the place of use are different (such as in the case of positive power supply grounding), the external control device used for external input should have an insulated on/off procedure for the 0V line (such as photocoupler output or relay output) in order to prevent short-circuits from occurring.

4 WIRING / PIPING

- Use the accessory relay cable to connect the main unit and the AC adapter.
- Use the accessory straight joint to connect a suitable air tube to the main unit.
- Connect the GND terminal of this product to a secure ground when using it.
- Since the pressure will drop when the air piping from the main pressure supply is extended or pneumatic-components (e.g., needle valve, speed-controller, minifilter) are added, keep an eye on the pressure supply to the ionizer making sure it isn't in short supply. For the pneumatic-components, select those that can accommodate the air supply flow rate.

* The air supplied should be dry, clean air (air drier: dew point approx. -20°C, air filter: mesh size of approx. 0.01µm).

⚠ CAUTION

- Turn off the power and air and make sure that the supply of air has been fully shut off before carrying out any wire and tube connection work. If this is not done, accidents or problems with operation may occur.
- The metal parts of the nozzle are connected inside the product to the 0V and GND terminal. Do not connect it to objects with a different electrical potential such as the conductive parts of external devices. If the supplied air contains any particles other than air or any corrosive gases, accidents or problems with operation may occur. In addition, if air which contains impurities such as carbon dust or air which contains moisture or oil is used, accidents or problems with operation may also occur.
- Do not modify the nozzle or install the nozzle to any other appliances, otherwise correct charge removal performance may not be obtained, and accidents or problems with operation may occur.

5 OPERATION

1. Use the mode select switches to select the required settings.
2. Face the ionizer toward the electrostatically-charged object and pull the trigger. When the trigger is pulled, dust removal operation will start, and when the trigger is released, dust removal operation will stop.

	Name	Position	Details
Mode select switches	Pulse air mode selection	12 CONT <input type="checkbox"/>	Pulse 1 (*)
		12 CONT <input type="checkbox"/>	Pulse 2 (*)
		12 CONT <input type="checkbox"/>	Continuous
LED illumination mode selection	ON SYNC OFF <input type="checkbox"/>	ON SYNC OFF <input type="checkbox"/>	Always ON
		ON SYNC OFF <input type="checkbox"/>	Synchronized with trigger
		ON SYNC OFF <input type="checkbox"/>	Always OFF

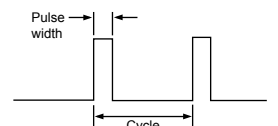

*: Pulse 1: Pulse ionized air emission cycle approx. 100ms, pulse width approx. 50ms
Pulse 2: Pulse ionized air emission cycle approx. 100ms, pulse width approx. 10ms

6 CARE AND MAINTENANCE

- Be sure to turn off the power and air before carrying out cleaning and maintenance.
- Make sure that the supply of air has been fully shut off and that all pressures at the product and inside the tubes are at zero before continuing. If this is not done, air pressure may cause operating problems or accidents.
- The discharge needle has a sharp point, so be very careful when cleaning the needle.
- Clean the discharge needle regularly about once a week, otherwise optimum charge removal performance may not be obtained and accidents or operating problems may occur.
- The discharge needle is a consumable part. If charge removal performance does not return to normal after the discharge needle has been cleaned, then the needle should be replaced.

Cleaning and replacing the discharge needle

1. Turn off the power and check that the air pressure inside the air tube has dropped to zero.
2. Remove the nozzle guard, turn the nozzle counterclockwise and remove it.
3. Remove the insulating pipe and the attachment.
4. When carrying out cleaning, use a cotton swab moistened in alcohol or similar to remove any dirt from the needle and the area around it. (If replacing the discharge needle, use needle nose pliers or a similar tool to pull out the needle, and then insert a new needle as far as it will go.)
5. After cleaning or replacing the needle, return the attachment, insulating pipe and nozzle to their normal installation positions. Turn the nozzle clockwise to install it. The tightening torque for the nozzle at this time should be 3N•m or less. Lastly, affix the nozzle guard.

*: Do not touch the tip of the discharge needle against tools or any other hard surfaces. If the discharge needle is damaged, optimum charge removal performance may not be obtained and accidents or problems with operation may occur. In addition, do not touch the stopper ring area, otherwise the stopper ring may slip out of position, and it may not be possible to reinstall it. When handling the discharge needle with tools, hold the discharge needle at the middle and avoid applying excessive force to the needle.

Note: When installing the attachment, make sure that it is facing the correct direction. If it is installed so that it is facing the wrong direction, it will not be possible to fully tighten the nozzle.

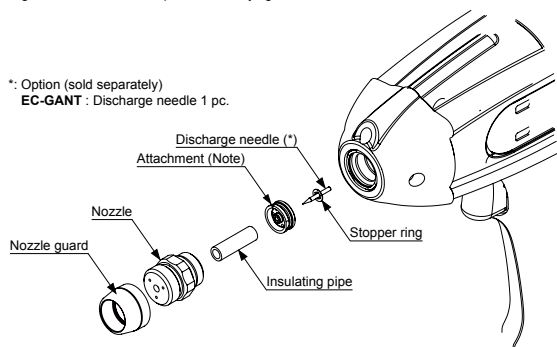

- The solenoid valve is a consumable part (open/close operations: approx. 8,000,000). If it no longer opens and closes normally, stop using the ionizer and replace the solenoid valve.

Solenoid valve replacement procedure

1. Check that the power is turned off and that the air pressure inside the air tube has dropped to zero.
2. Remove the back cover. Remove the four M3 mounting screws. (A in diagram below)
3. Disconnect the air tube from the solenoid valve. (B in diagram below)
4. Disconnect the solenoid valve lead wire connector.
5. Remove the two M3 mounting screws. (C in diagram below)
6. Disconnect the air pipe from the solenoid valve. (D in diagram below)
7. Install the new solenoid valve, and then install the M3×45 mounting screws and connect the air tubes and the solenoid valve lead wire connector. Tighten the M3×45 mounting screws at a torque of 0.2N•m or less.
8. Install the back cover. Let the lead wire pass the lead wire holder, and make sure that the cover will not catch lead wire. Tighten the M3×10 mounting screws at a torque of 0.4N•m or less.

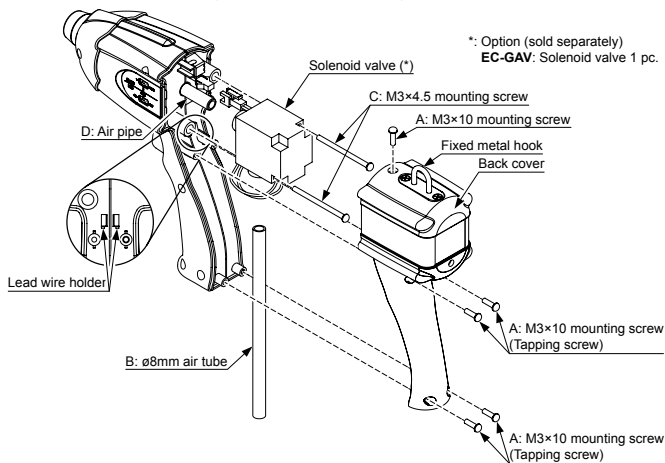

7 TROUBLESHOOTING

When an error is detected, the white LED flashes. (It also flashes even when the LED illumination mode is set to "Always OFF".) If the white LED is flashing, carry out the following checking operations. When checking the discharge area, always be sure to turn off the power before carrying out the checking.

- Turn off the power and check that the tip of the needle is intact and that there is no dirt on it, and that the needle is installed correctly.
- Check that there are no foreign objects inside the nozzle.
- Check that the nozzle is installed correctly. (Including the attachment and the insulating pipe)
- Check that the air pressure is within the specification range.

8 SPECIFICATIONS

Type	Pulse Air-gun Ionizer
Model No.	EC-G02
Charge removal time (±1,000V → ±100V)	0.5 sec. or less (Note 1)
Ion balance	±10V or less (Note 1)
Power supply voltage	Accessory AC adapter INPUT: 100 to 240V AC±10% 50/60Hz (OUTPUT: 24V DC)
Power consumption	30VA or less
Discharge method	High-frequency AC method
Discharge output voltage	2000V approx.
Ozone generation	0.02ppm or less (Note 2)
Applicable fluid	Air (dried clean air)
External input	Ionized air emission operation ON/OFF using OR control with trigger switch <ul style="list-style-type: none"> • Ionized air emission operation ON: Short-circuited to COM (-) • Ionized air emission operation OFF: Open
Indicators	Valve illumination: Illuminated when solenoid valve is ON (open) (orange LED)
Error detection function	When an abnormal discharge (short-circuited, etc.) occurs, discharge is forcibly stopped and the spotlight flashes (reset when the power is turned off and back on) (Note 3)
Ambient temperature	0 to + 50°C (No dew condensation), AC adapter: 0 to +40°C
Ambient humidity	35% to 65% RH (No dew condensation)
Supplied air flow	Max. 300 l/min. (ANR) or less
Air pressure range	0.05 to 0.50 MPa
Material	Enclosure: ABS, Nozzle: Stainless steel, Discharge needle: Tungsten Nozzle guard: NBR
Weight	270g approx. (main unit only)
Accessories	<ul style="list-style-type: none"> • AC adapter 1 pc. • Exclusive intermediate cable (oil-proof / heat-proof / winding-proof type) length 2m: 1 pc. • Straight joints • Tube outer diameter ø8mm-ø8mm compatible type 1 pc. (Note 4) • Tube outer diameter ø8mm-ø6mm compatible type 1 pc. • Connector connection terminal (manufactured by Molex) 3 pcs.

Notes: 1) Typical value for continuous pulse air mode at 100mm from end of discharge nozzle at an applied air pressure of 0.50MPa
2) Typical value for continuous pulse air mode at 300mm from end of discharge nozzle at an applied air pressure of 0.25MPa
3) Once an error is detected, the error status is maintained until the power is turned off and back on again. Remove the cause of the error and then turn the power back on. If the cause of the error is not removed, the error will occur once more.
4) At the time of shipment from the factory, ø8mm-ø8mm type is attached.

9 CAUTIONS

- This product has been developed / produced for industrial use only.
- Do not use this product for any purpose other than charge removal and dust removal.
- Do not use this product in environments which are outside the specification range, otherwise operating problems or damage may occur. In addition, the operating life of the product may become significantly reduced.
- Never disassemble, repair or modify this product, otherwise operating problems or accidents may occur.
- Do not dispose of this product by burning it, otherwise it may explode or toxic fumes may be generated.
- This product generates ozone, so be sure to provide adequate ventilation if using it in a confined space.
- Do not run the wires together with high-voltage lines or power lines or put them in the same raceway. This can cause malfunction due to induction.
- Be sure to turn off the air and the power supply before carrying out any cable connection or inspection work. If this is not done, operating problems, damage or electric shocks may occur.
- After connecting the cables, check that the air piping and power supply connections are correct before turning on the power. If the wires or cables are connected incorrectly, operating problems or accidents may occur.
- Verify that the supply voltage variation is within the rating.
- Do not turn the power back on immediately after it has been turned off, otherwise operating problems or accidents may occur. In addition, the operating life of the product may become significantly reduced. Wait at least 2 seconds before turning the power back on again.
- Do not use the power plug of the AC adapter if it has become dusty, otherwise fire may occur.
- The air tube or cable may be broken if excessive tension or other stress is applied to the air tube and cable. Consider appropriate margins of the air tube and cable within the work area when using them.
- Do not use any cables which have any damage (such as splitting or cracking), otherwise operating problems or accidents may occur.
- Avoid using the product in places where there are high levels of steam or dust in the air or where it might be directly exposed to water, oil or welding spatter.
- Do not touch the discharge needle with hard objects such as tools. If the discharge needle becomes broken, it will not provide sufficient charge removal performance, and moreover operating problems or accidents may occur.
- If this product ceases functioning or is no longer required, dispose of it according to appropriate local waste disposal regulations.
- This product is a high-precision device, and should be handled with care.

10 INTENDED PRODUCTS FOR CE MARKING

- The models listed under "8 SPECIFICATIONS" come with CE Marking. As for all other models, please contact our office.



- **Contact for CE**
Panasonic Marketing Europe GmbH Panasonic Testing Center
Winsbergweg 15, 22525 Hamburg, Germany

Panasonic Industrial Devices SUNX Co., Ltd.

<http://panasonic.net/id/pidsx/global>

Overseas Sales Division (Head Office)

2431-1 Ushiyama-cho, Kasugai-shi, Aichi, 486-0901, Japan
Phone: +81-568-33-7861 FAX: +81-568-33-8591

About our sale network, please visit our website.

PRINTED IN JAPAN

© Panasonic Industrial Devices SUNX Co., Ltd. 2014