

# Panasonic INSTRUCTION MANUAL

## Electrostatic Sensor Controller

### EF-S1C

CME-EFS1C No.0032-47V

Thank you very much for using Panasonic products. Please read this Instruction Manual carefully and thoroughly for the correct and optimum use of this product. Kindly keep this manual in a convenient place for quick reference.

**WARNING**

- Never use this product with a device for personnel protection.
- In case of using devices for personnel protection, use products which meet laws or standards, such as OSHA, ANSI or IEC etc., for personnel protection applicable in each region or country.

## 1 OUTLINE

- This product can be used in combination with a exclusive sensor head (EF-S1HS) (optional) to monitor electrical potentials on object surfaces.
- It can also be used together with an ionizer to check results of charge removal processes.

## 2 PART DESCRIPTION

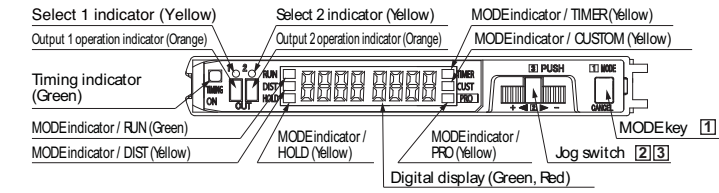

## 3 MOUNTING

### How to mount the controller

- Fit the rear part of the mounting section of the controller on a 35mm width DIN rail.
- Press down the rear part of the mounting section of the unit on the 35mm width DIN rail and fit the front part of the mounting section to the DIN rail.

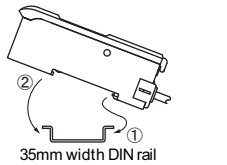

### How to remove the controller

- Push the controller forward.
- Lift up the front part of the controller to remove it.

Note: Take care that if the front part is lifted without pushing the controller forward, the hook on the rear portion of the mounting section is likely to break.

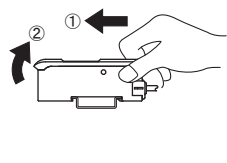

### How to mount the sensor head

- Insert the sensor head connector into the inlet until it clicks.
- Fit the cover to the connector.

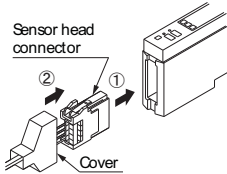

## 4 I/O CIRCUIT DIAGRAM

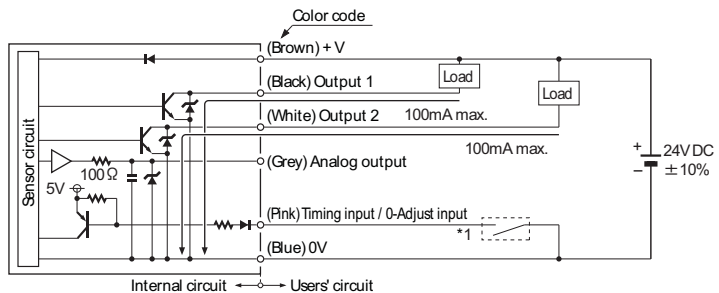

Note: If using together with an ionizer manufactured by Panasonic, share the 0V line of this product with the ground of the ionizer, and carry out 0-Adjust when doing 0V measurements.

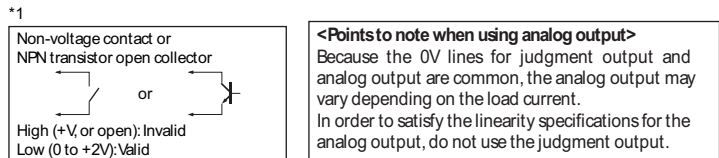

## 5 OPERATION PROCEDURE AND BASIC SYSTEM

MODEkey	Jog switch		3] Press
	2] Turn	1] Press	
1] Press	Turn	Turn	Press
<ul style="list-style-type: none"> <li>Switching NAVI mode</li> <li>Canceled while setting is in progress</li> <li>0-Adjust</li> </ul>	<ul style="list-style-type: none"> <li>Moving setting menu</li> <li>Changing setting values</li> <li>Display value hold</li> </ul>	<ul style="list-style-type: none"> <li>Confirming menu settings</li> <li>Confirming setting values</li> </ul>	

### Basic system of operation for NAVI mode (For details, refer to '7 NAVI MODE.')

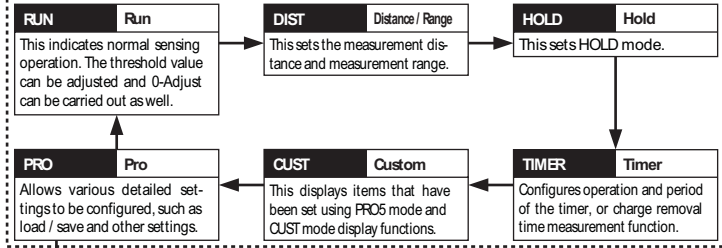

### Basic system of operation for PRO mode (For details, refer to '9 PRO MODE.')

Notes: 1) Judgment output and analog output will become unstable while setting operations are being carried out. After settings have been completed, use in RUN mode.  
2) If the power is turned off while settings are being confirmed (while the display is blinking), the settings may not be applied correctly.

## 6 RUN MODE

- In this mode, the current measurement value and threshold value are displayed. (Note 1) and the threshold value can be set and 0-Adjust, key lock and display value hold and charge removal time measurement operations can be carried out.

Notes: 1) At the time of shipment, the threshold value is set to be displayed in the green (left) digital display. When the symbol display setting is ON (refer to PRO2 mode), a symbol (" " only) appears in the green (left) digital display.

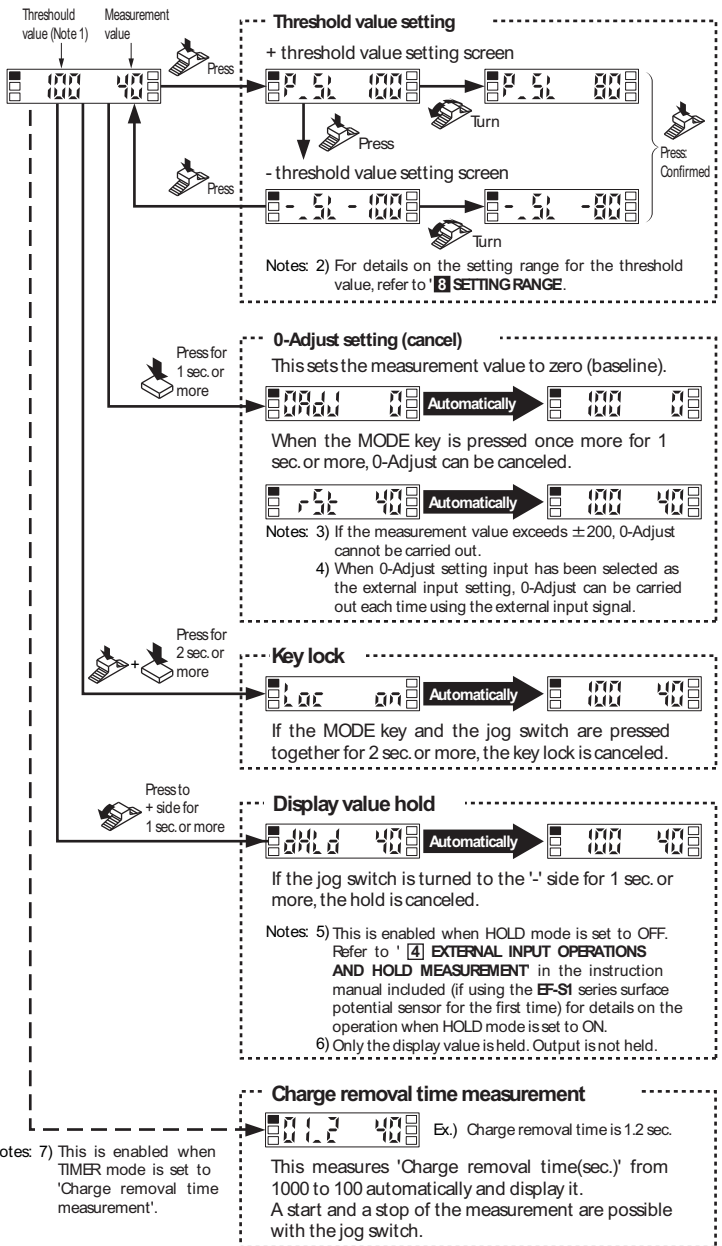

## 7 NAVI MODE

- If the MODEkey is pressed, the mode can be changed to a different mode.

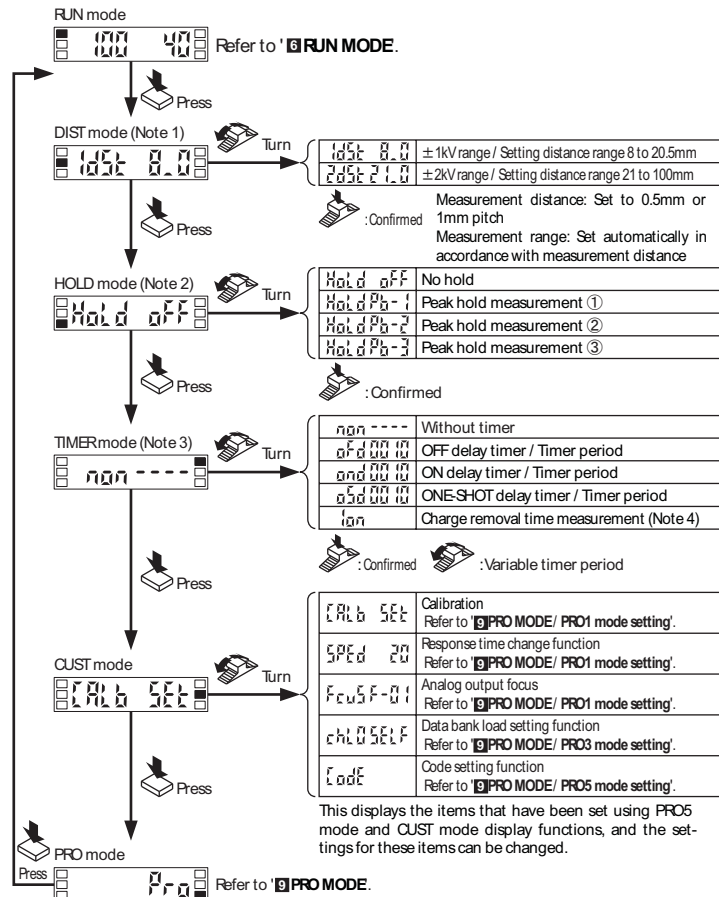

Notes: 1) For details, refer to '8 SETTING RANGE.'  
2) The values that are displayed during RUN mode will vary as shown in the table below depending on the setting for HOLD mode. ('-' against the displayed value means that the value is negative.)

HOLD mode setting	Display during RUN mode
Hold OFF	Threshold value / Measurement value
Hold Pb-1	Threshold value / Peak value
Hold Pb-2	+ peak value / - peak value
Hold Pb-3	Peak value / Measurement value

- If HOLD mode is set to 'Pb-1', 'Pb-2' or 'Pb-3', the timer function will be automatically set to 'none' (no timer), and it will not be possible to change timer operation.
- When charge removal time measurement has been selected, the output operation will be without timer.

## 8 SETTING RANGE

- The threshold value can be set to within the following range.
  - Distance 8 to 20.5mm:  $+5 \leq$  +Threshold value  $\leq +500$  ( $\pm 1kV$  range)  $-5 \geq$  -Threshold value  $\geq -500$
  - Distance 21 to 100mm:  $+5 \leq$  +Threshold value  $\leq +1,000$  ( $\pm 2kV$  range)  $-5 \geq$  -Threshold value  $\geq -1,000$
- 0-adjust can be set to within the following range.
  - $-200 \leq$  Measurement value  $\leq +200$
- Calibration can be set to within the following range.
  - $0.5 \leq$  (Display hold value / Current measurement value)  $\leq 10$
  - Distance 8 to 20.5mm:  $-1,000 \leq$  Measurement value  $\leq +1,000$
  - Distance 21 to 100mm:  $-1,999 \leq$  Measurement value  $\leq +1,999$

## 9 PRO MODE

- If 'PRO' is selected in NAVI mode, the mode changes to PRO mode.

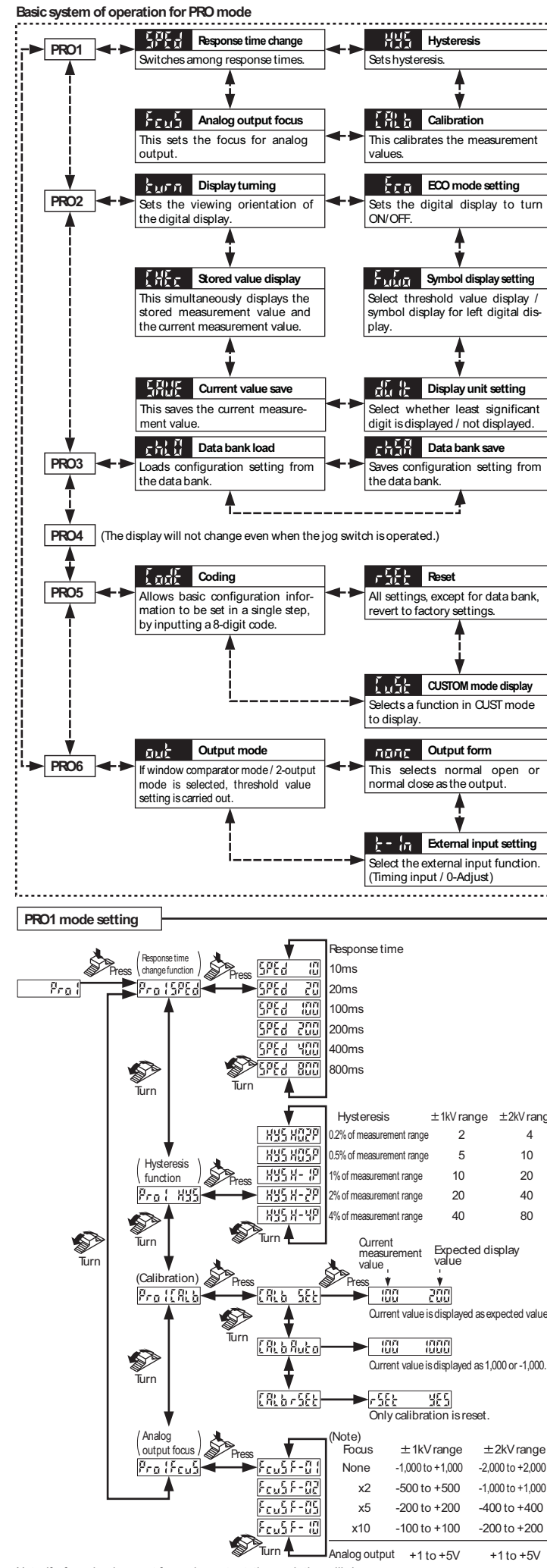

Note: If a focus has been set for analog output, the resolution will change.

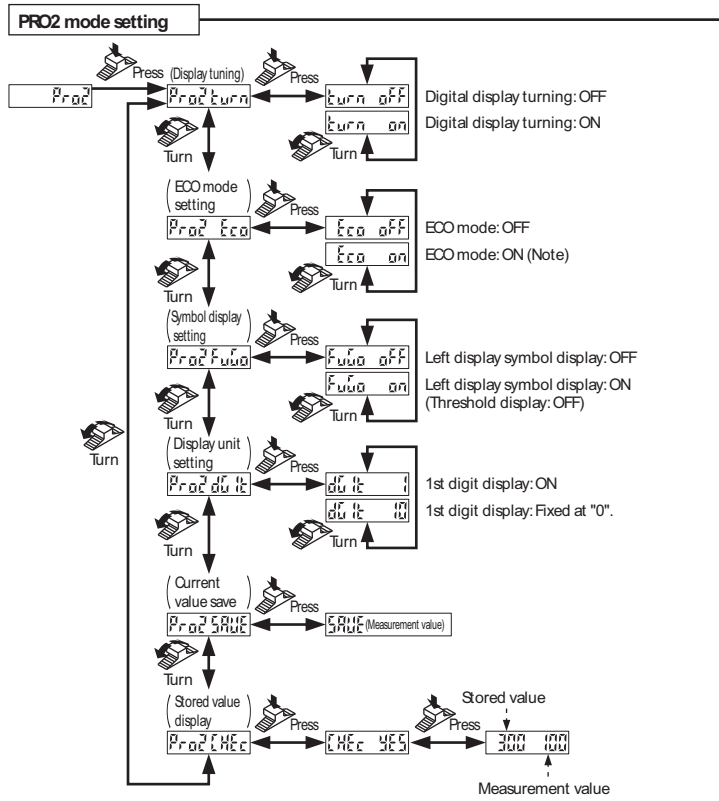

Note: When RUN mode, if no key is pressed for a certain period of time, the digital display will turn off. The display will be restored when a key is pressed.

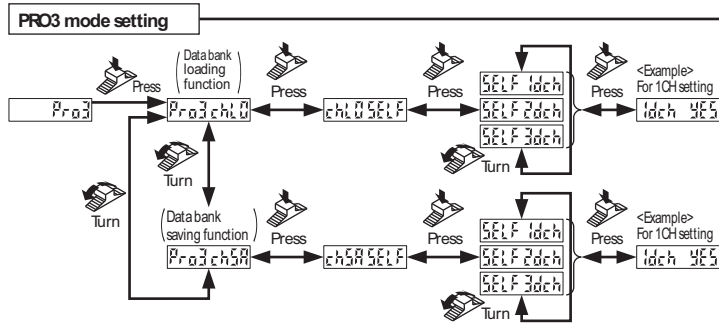

Note: The data bank has three channels for each controller. The data bank can load and save the items that are displayed in **11** FACTORY SETTING.

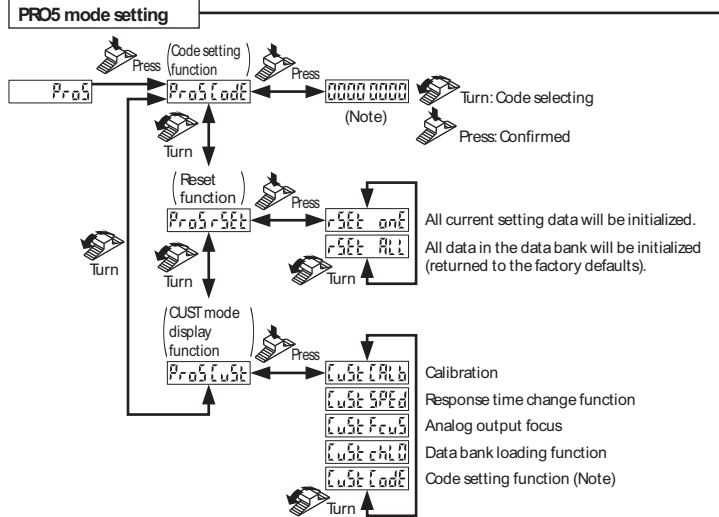
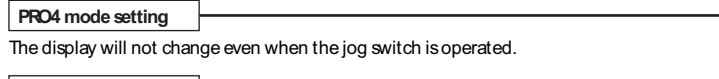

Note: Refer to **10** LIST OF CODE SETTING when using the code setting function.

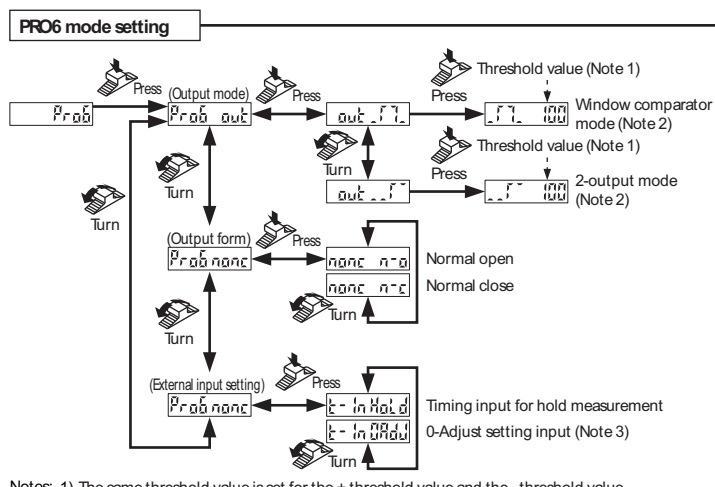

Notes: 1) The same threshold value is set for the + threshold value and the - threshold value.  
 2) For window comparator mode, the Select 1 indicator (yellow) will light up. For 2-output mode, the Select 1 indicator (yellow) and the Select 2 indicator (yellow) will light up.  
 3) The external input signal is used to carry out 0-Adjust each time. To cancel 0-Adjust, press and hold the MODE key for 1 second or more. (It cannot be canceled by means of an external input signal.)

**10 LIST OF CODE SETTING**

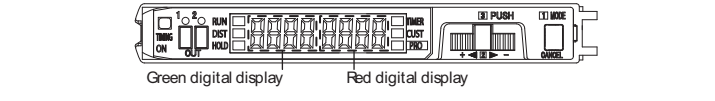

**Green digital display**

First digit	Second digit	Third digit	Fourth digit
Direct code	Output form (OUT1, OUT2)	Direct code	Timer operation (Note)
1	Normal open	1	Off
2	Normal close	2	ON delay
3	—	3	OFF delay
4	—	4	ONE-SHOT delay
5	—	5	Charge removal time measurement
6	—	6	—
7	—	7	—
8	—	8	—
9	—	9	—

**Red digital display**

First digit	Second digit	Third digit	Fourth digit
Direct code	Hysteresis function	Direct code	External input
1	2%	1	No hold
2	4%	2	Peak ①
3	4%	3	Peak ②
4	1%	4	Peak ③
5	1%	5	No hold
6	0.2%	6	Peak ①
7	0.2%	7	Peak ②
8	0.5%	8	Peak ③
9	0.5%	9	—

Note: If timer operation and HOLD mode have been set simultaneously, HOLD mode will take priority, and timer operation will be set to 'without timer'.

**11 FACTORY SETTING**

- The default settings (factory settings) for this product are listed below. The settings can be reset to the default settings (factory settings) using setting reset in PRO mode. For details, refer to **9** PRO MODE/ PRO5 mode setting.
- NAM mode**

Item	Initial setting value	Digital display	
		Green	Red
Threshold value	+ potential (OUT1)	100	100
	- potential (OUT1)	-100	-100
0-Adjust	No 0-Adjust	000	(Measurement value)
DIST mode	±1kV range, Setting distance 8mm	100	000
HOLD mode	Hold OFF	Hold	OFF
TIMER mode	Without timer	000	---
CUST mode	Calibration	100	500

**PRO mode**

Item	Initial setting value	Digital display	
		Green	Red
Response time change function	20ms	20	20
Hysteresis function	2% of ±1kV range (20)	2	2
Calibration	Without calibration (x1)	(Measurement value)	(Expected value)
Analog output focus	Without focus (x1)	F00	F01
Display turning	OFF	0FF	0FF
ECO mode setting	OFF	0FF	0FF
Code setting function	0000 0000	0000	0000
Output mode	Window comparator mode	000	---
Output form	Normal open	000	---
Symbol display setting	OFF	0FF	0FF
Display unit setting	Displayed up to 1st line (1)	00	---
External input setting	Timing input for hold measurement	---	---

**12 TIMER FUNCTION**

- Identical timer operations (ON delay, OFF delay, ONE-SHOT delay) and timer periods can be set for OUT1 and OUT2.
- The timer period can be set in units of 1ms up to a maximum of 9,999ms.
- Timer functions cannot be set while HOLD mode is set.
- If HOLD mode is set after timer function has already been set, the timer will be automatically set to 'hold' (without timer).
- For details on the timer function setting method, refer to **7** NAM MODE.

**Timing chart**

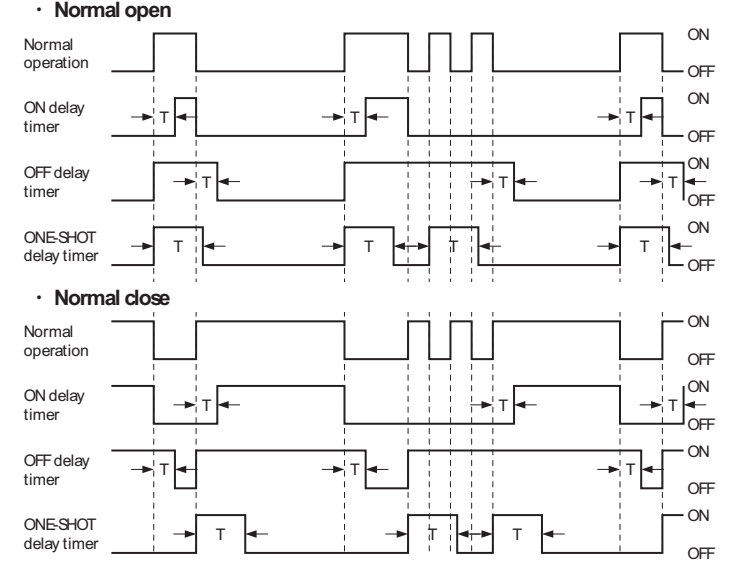

**13 ERROR DISPLAY**

Take the following actions in case of errors.

Display	Output operation	Description of error	Action
Err - 1	—	Overcurrent has been applied due to short-circuited load.	Turn off the power supply and check the load.
H. 0u	OUT2: ON Analog: 5V	+ potential is outside the range.	If using the ±1kV range, set the measurement distance to 21mm or more, and use the ±2kV range.
L. 0u	OUT2: ON Analog: 1V	Disconnection error in sensor head, or - potential is outside the range.	If the error is not cleared when measuring at 0V, the problem is a disconnection error. Check the connection status for the sensor head. If the error is cleared when measuring at 0V, the - potential is outside the range. Set the measurement distance to 21mm or more, and use the +2kV range.
Err 000	—	The setting exceeds the 0-Adjust setting range.	Cancel 0-Adjust and check the measurement values.

Note: If OUT2 is used for over-range output, the output mode must be set to window comparator mode.

**14 MAJOR SPECIFICATIONS**

Designation		Electrostatic sensor controller
Item	Model No.	EF-S1C
Applicable sensor head		EF-S1HS
Supply voltage		24V DC ± 10%
Current consumption		Normal operation: 50mA or less, ECO mode: 40mA or less
Measurement distance (measurement range)		8 to 20.5mm (±1kV range), 21 to 100mm (±2kV range) (Note 1)
Repeatability		±0.3%FS (Note 2)
Linearity		±0.5%FS (Note 2, 3)
Temperature characteristics		0.05%FS/°C (Note 4)
Judgment output (OUT1, OUT2)		NPN open-collector transistor • Maximum sink current: 100mA • Applied voltage: 30V DC or less (between judgment output and 0V) • Residual voltage: 1.5V or less (at 100mA sink current)
Response time		10ms/ 20ms/ 100ms/ 200ms/ 400ms/ 800ms
Output operation		OUT1: + judgment output or window comparator output OUT2: - judgment output or error output
Short-circuit protection		Incorporated
Analog output (Note 5)		• Output voltage: +1 to +5V • Output impedance: 100Ω approx.
Response time		20ms/ 30ms/ 110ms/ 210ms/ 410ms/ 810ms
Timing input		NPN non-contact input • Signal condition: High: +V, or open Low: 0 to +2V (source current 0.5mA) • Input impedance: 10kΩ approx.
Ambient temperature		-10 to +55°C (No dew condensation or icing allowed), Storage: -20 to +70°C
Ambient humidity		35 to 85% RH, Storage: 35 to 85% RH
Material		Enclosure: Heat-resistant ABS, Transparent cover: Polycarbonate Press switches: Acrylic, Jog switch: Heat-resistant ABS
Cable		0.2mm <sup>2</sup> 6-core cable, 2m long
Weight		65g approx.

Notes: 1) This product's measurement values vary depending on the measurement distance. Set the measurement distance and use at a fixed distance. The measurement distance can be set at a pitch of 0.5mm (distances of 40 mm or more are at 1 mm pitch).  
 2) The repeatability precision and linearity values given are those for no calibration and no analog output focus.  
 3) The values given are for when the measured value is ±200V in the ±1kV range and ±400V in the ±2kV range. If the measured values are outside these values, the values will be equal to the displayed values ±5%.  
 4) The values given are when used together with the exclusive sensor head. The values given are for when the measured value is ±200V in the ±1kV range and ±400V in the ±2kV range. If the measured values are outside these values, the values will be 0.5% of the displayed values.  
 5) In order to satisfy the linearity specifications for the analog output, do not use the judgment output.  
 6) F.S. is 2,000 for the ±1kV range and 4,000 for the ±2kV range.

**15 CAUTIONS**

- This product has been developed / produced for industrial use only.
- Make sure that the power supply is off while wiring.
- Verify that the supply voltage variation is within the rating.
- Take care that if a voltage exceeding the rated range is applied, or if an AC power supply is directly connected, the sensor may get burnt or damaged.
- In case noise generating equipment (switching regulator, inverter motor, etc.) is used in the vicinity of this product, connect the frame ground (FG) terminal of the equipment to an actual ground.
- If power is supplied from a commercial switching regulator, ensure that the frame ground (FG) terminal of the power supply is connected to an actual ground.
- Do not use during the initial transient time (3 sec.) after the power supply is switched on.
- In order for stable sensing to be carried out, wait for 10 minutes after turning on the power before use.
- Take care that short-circuit of the load or wrong wiring may burn or damage the sensor.
- There is no short-circuit protection circuit for analog output installed. Do not connect the power supply or capacity load directly.
- Do not run the wires together with high-voltage lines or power lines or put them in the same raceway. This can cause malfunction due to induction.
- Extension up to total 10m is possible with 0.15mm<sup>2</sup> or more, cable. However, in order to reduce noise, make the wiring as short as possible.
- This sensor is suitable for indoor use only.
- Avoid dust, dirt, and steam.
- Take care that the product does not come in direct contact with water, oil, grease, or organic solvents, such as, thinner, etc.
- This sensor cannot be used in an environment containing inflammable or explosive gases.
- Never disassemble or modify the sensor.

**16 INTENDED PRODUCTS FOR CE MARKING**

- The models listed under **14** SPECIFICATIONS come with CE Marking. As for all other models, please contact our office.

**Contact for CE**  
 <Until June 30 ,2013>  
 Panasonic Industrial Devices Sales Central Europe AG  
 Rudolf-Diesel-Ring 2, D-83607 Holzkirchen, Germany  
 <From July 1 ,2013>  
 Panasonic Marketing Europe GmbH Panasonic Testing Center  
 Winsbergring 15, 22525 Hamburg, Germany

**Panasonic Industrial Devices SUNX Co., Ltd.**

http://panasonic.net/id/pidsx/global  
**Overseas Sales Division (Head Office)**  
 2431-1 Ushiyama-cho, Kasugai-shi, Aichi, 486-0901, Japan  
 Phone: +81-568-33-7861 FAX: +81-568-33-8591  
 About our sale network, please visit our website.  
 PRINTED IN JAPAN © Panasonic Industrial Devices SUNX Co., Ltd. 2012