

Digital Fiber Sensor Amplifier FX-305(P)

MJE-FX305 No.0034-49V

Thank you very much for purchasing Panasonic products. Please read this Instruction Manual carefully and thoroughly for the correct and optimum use of this product. Kindly keep this manual in a convenient place for quick reference.



WARNING

- Never use this product as a sensing device for personnel protection.
- In case of using sensing devices for personnel protection, use products which meet standards, such as OSHA, ANSI or IEC etc., for personnel protection applicable in each region or country.

For further details on the fiber sensor amplifier, please refer to 'Panasonic Industrial Devices SUNX website (<http://panasonic.net/id/pidsx/global>)' or contact our office.

1 SPECIFICATIONS

Type	NPN output	PNP output
Item	Model No. FX-305	Model No. FX-305P
Supply voltage	12 to 24V DC ±10% Ripple P-P 10% or less	
Power consumption (Note 2)	Normal operation: 960mW or less (current consumption 40mA or less at 24V supply voltage) ECO mode: 600mW or less (current consumption 25mA or less at 24V supply voltage)	
Output (Output 1, Output 2)	NPN open-collector transistor • Maximum sink current: each 50mA (Note 1) • Applied voltage: 30V DC or less (between output and 0V) • Residual voltage: 1.5V or less [at each 50mA (Note 1) sink current]	PNP open-collector transistor • Maximum source current: each 50mA (Note 1) • Applied voltage: 30V DC or less (between output and +V) • Residual voltage: 1.5V or less [at each 50mA (Note 1) source current]
Output operation	Light-ON or Dark-ON, selectable with jog switch	
Short-circuit protection	Incorporated	
Response time	H-SP: 65 μs or less, FAST: 150 μs or less, STD: 250 μs or less STDF: 700 μs or less, LONG: 2.5ms or less, U-LG: 4.5ms or less selectable with jog switch	
Display	4 digit red LED display	
Sensitivity setting	Normal mode	2-level teaching / Limit teaching / Full-auto teaching / Max. sensitivity teaching / Manual adjustment
	Window comparator mode	Teaching (1-level / 2-level / 3-level) / Manual adjustment
Fine sensitivity adjustment function	Incorporated	
Timer function	Incorporated with variable ON-delay / OFF-delay / ONE-SHOT / ON-delay · OFF-delay / ON-delay · ONE-SHOT timer, switchable either effective or ineffective (Timer: approx. 0.5 to 9999ms)	
Interference prevention function (Note 2) (Note 3)	Incorporated [up to four fibers can be mounted adjacently (However, U-LG mode is eight fibers, H-SP mode is two fibers.)]	
Ambient temperature	-10 to +55°C (if 4 to 7 units are connected in cascade: -10 to +50°C, if 8 to 16 units are connected in cascade: -10 to +45°C) (No dew condensation or icing allowed), Storage: -20 to +70°C	
Ambient humidity	35 to 85% RH, Storage: 35 to 85% RH	
Emitting element	Red LED (modulated)	
Material	Enclosure: Heat-resistant ABS, Transparent cover: Polycarbonate Press switches: Acrylic, Jog switch: Heat-resistant ABS	
Weight	20g approx.	
Accessory	FX-MB1 (Amplifier protection seal): 1 set	

- Notes: 1) 50mA per output. 25mA if five, or more, amplifiers are connected in cascade.
2) When the interference prevention function 'IP-2' is set, the number of mountable fibers becomes double. Furthermore, take care that the response time also becomes double. For the setting method, refer to 'PRO MODE · PRO5 mode setting'.
3) When the power supply is switched on, the light emission timing is automatically set for interference prevention.
4) The cable for amplifier connection is not supplied as an accessory. Make sure to use the optional quick-connection cables given below.
Main cable (4-core): CN-74-C1 (cable length 1m), CN-74-C2 (cable length 2m)
CN-74-C5 (cable length 5m)
Sub cable (2-core): CN-72-C1 (cable length 1m), CN-72-C2 (cable length 2m)
CN-72-C5 (cable length 5m)

2 MOUNTING

How to mount the amplifier

- Fit the rear part of the mounting section of the amplifier on a 35mm width DIN rail.
- Press down the rear part of the mounting section of the unit on the 35mm width DIN rail and fit the front part of the mounting section to the DIN rail.

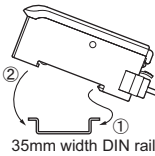

How to remove the amplifier

- Push the amplifier forward.
- Lift up the front part of the amplifier to remove it.

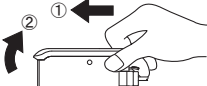

Note: Take care that if the front part is lifted without pushing the amplifier forward, the hook on the rear portion of the mounting section is likely to break.

How to connect the fiber cables

Be sure to fit the attachment to the fibers first before inserting the fibers to the amplifier. For details, refer to the instruction manual enclosed with the fibers.

- Snap the fiber lock lever down.
- Insert the fiber cables slowly into the inlets until they stop. (Note 1)
- Return the fiber lock lever to the original position, till it stops.

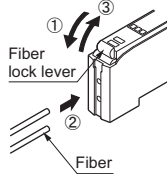

- Notes: 1) In case the fiber cables are not inserted to a position where they stop, the sensing range reduces. In case of a flexible fiber, take care that it may bend inside the amplifier, during insertion.
2) With the coaxial reflective type fiber, such as FD-G4 or FD-FM2, insert the single-core fiber cable into the beam-emitting inlet and the multi-core fiber cable into the beam-receiving inlet. If they are inserted in reverse, the sensing accuracy will deteriorate.

3 CAUTIONS

- This product has been developed / produced for industrial use only.
- When the emission halt of the emitting power switching function is set from 'OFF' to 'ON', the output may be unstable. Do not use the output control for 0.5 sec. after starting emission.
- Make sure that the power supply is off while wiring.
- Verify that the supply voltage variation is within the rating.
- Take care that if a voltage exceeding the rated range is applied, or if an AC power supply is directly connected, the sensor may get burnt or damaged.
- In case noise generating equipment (switching regulator, inverter motor, etc.) is used in the vicinity of this product, connect the frame ground (F.G.) terminal of the equipment to an actual ground.
- If power is supplied from a commercial switching regulator, ensure that the frame ground (F.G.) terminal of the power supply is connected to an actual ground.
- Do not use during the initial transient time (0.5 sec.) after the power supply is switched on.
- Take care that short-circuit of the load or wrong wiring may burn or damage the sensor.
- Do not run the wires together with high-voltage lines or power lines or put them in the same raceway. This can cause malfunction due to induction.
- Make sure to use the optional quick-connection cable for the connection of the amplifier.
- Extension up to total 100m (if 5 to 8 units are connected in cascade: 50m, if 9 to 16 units are connected in cascade: 20m) is possible with 0.3mm², or more, cable. However, in order to reduce noise, make the wiring as short as possible. Furthermore, take care that cable extension increases the residual voltage.
- This sensor is suitable for indoor use only.
- Avoid dust, dirt, and steam.
- Take care that the product does not come in contact with water, oil, grease, organic solvents, such as, thinner, etc., strong acid or alkaline.
- This sensor cannot be used in an environment containing inflammable or explosive gases.
- Never disassemble or modify the sensor.

4 CASCADING

- Make sure that the power supply is off while adding or removing the amplifiers.
- Make sure to check the allowable ambient temperature, as it depends on the number of amplifiers connected in cascade.
- In case two, or more, amplifiers are connected in cascade, make sure to mount them on a DIN rail.
- When the amplifiers move on the DIN rail depending on the attaching condition or the amplifiers are mounted close to each other in cascade, fit them between the optional end plates (MS-DIN-E) mounted at the two ends.
- When connecting amplifiers not close to each other in parallel, be sure to mount the optional end plate (MS-DIN-E) at both sides of each amplifier or affix the communication window seal of the accessory amplifier protection seal (FX-MB1) to the communication window.
- Up to maximum 15 amplifiers can be added (total 16 amplifiers connected in cascade.)
- When connecting more than two amplifiers in cascade, use the sub cable (CN-72-C□) as the quick-connection cable for the second amplifier onwards.
- The settings other than the interference prevention function cannot be transmitted between this product and other digital fiber amplifiers. Therefore, in case both models of amplifiers are mounted in cascade, be sure to mount identical models together. However, the interference prevention function is not incorporated in the FX-301(P)-HS and FX-303(P). Take care when the sensors are mounted in cascade.
- The communication function of this product and that of the FX-301(P)-F is different. If these models are mounted in cascade, affix the accessory amplifier protection seal (FX-MB1) to the communication windows of the amplifiers.

For mounting and removing the amplifier, refer to '2 MOUNTING'.

Cascading method

- Mount the amplifiers, one by one, on the 35mm width DIN rail.
- Slide the amplifiers next to each other, and connect the quick-connection cables.
- Mount the optional end plates (MS-DIN-E) at both the ends to hold the amplifiers between their flat sides.
- Tighten the screws to fix the end plates.

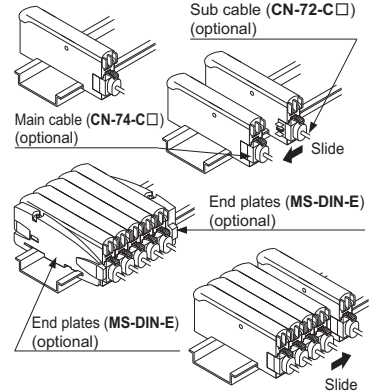

Dismantling

- Loosen the screws of the end plates.
- Remove the end plates.
- Slide the amplifiers and remove them one by one.

5 I/O CIRCUIT DIAGRAMS

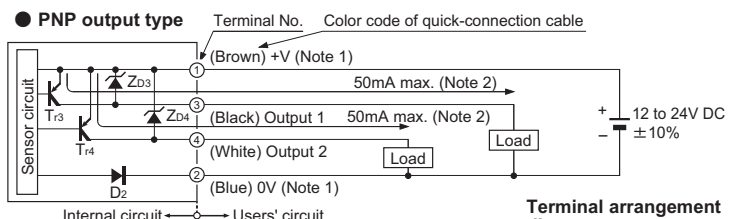
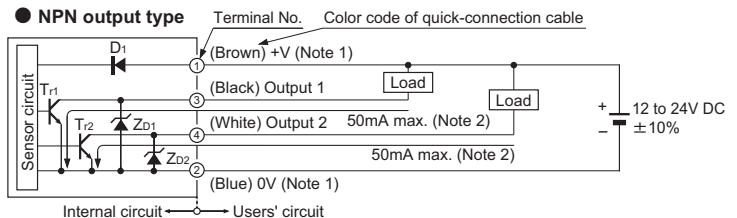

- Notes: 1) The quick-connection sub cable does not have +V (brown) and 0V (blue). The power is supplied from the connector of the main cable.
2) 25mA max. if five, or more, amplifiers are connected in cascade.

Symbols... D1, D2: Reverse supply polarity protection diode
ZD1, ZD2, ZD3, ZD4: Surge absorption zener diode
Tr1, Tr2: NPN output transistor
Tr3, Tr4: PNP output transistor

Terminal arrangement diagram

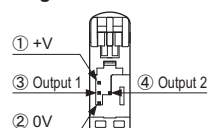

6 PART DESCRIPTION

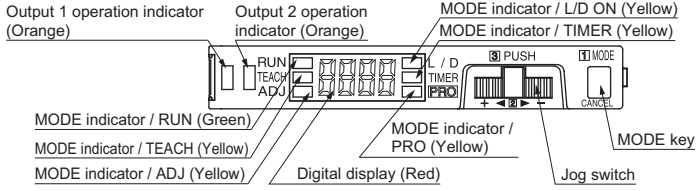

7 OPERATION PROCEDURE

- When the power supply is switched on, communication self-check is carried out and normal condition is displayed [MODE indicator / RUN (green)] lights up and the digital display shows the incident light intensity.

MODE key		Jog switch	
Press	Press	Turn	
		'+' side	'-' side

- *1: When JOG switch is pressed, the setting is confirmed.
- *2: When MODE key is pressed for 2 sec., or more, the sensor returns to the 'RUN' mode.
- *3: Cancellation is possible by pressing MODE key during setting.
- *4: When Jog switch is turned in the 'RUN' mode, the current threshold value is displayed. And then, the current incident light intensity display appears again automatically.
- *5: If the jog switch and MODE key are pressed for more than 2 sec. at the same time in 'RUN' mode condition, the key operations are locked, and only the threshold value confirmation function or the adjust function (valid only when the adjust lock function is canceled) is valid. To cancel the lock function, press both the keys for more than 2 sec. once again.

The items that can be set in output 1 and output 2 respectively are only the following. The items other than those are common.

- ① Threshold value ② Output operation ③ Timer operation and Timer period ④ Detection mode

● NAVI mode

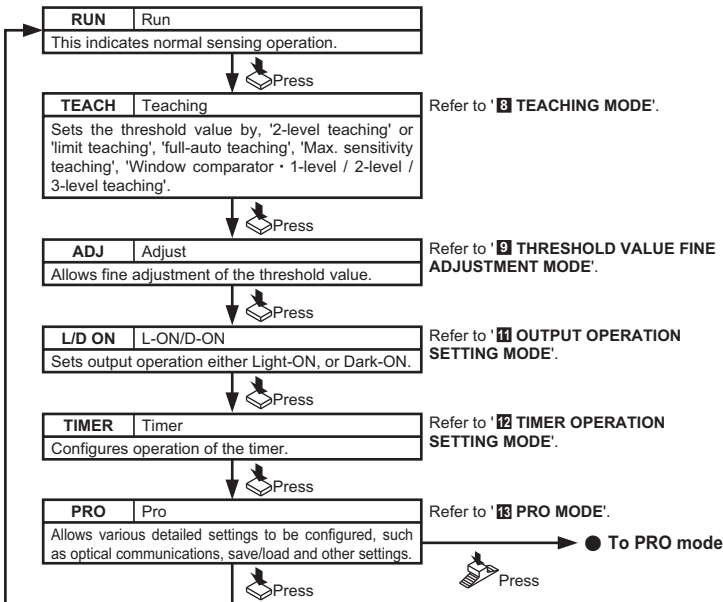

● PRO mode

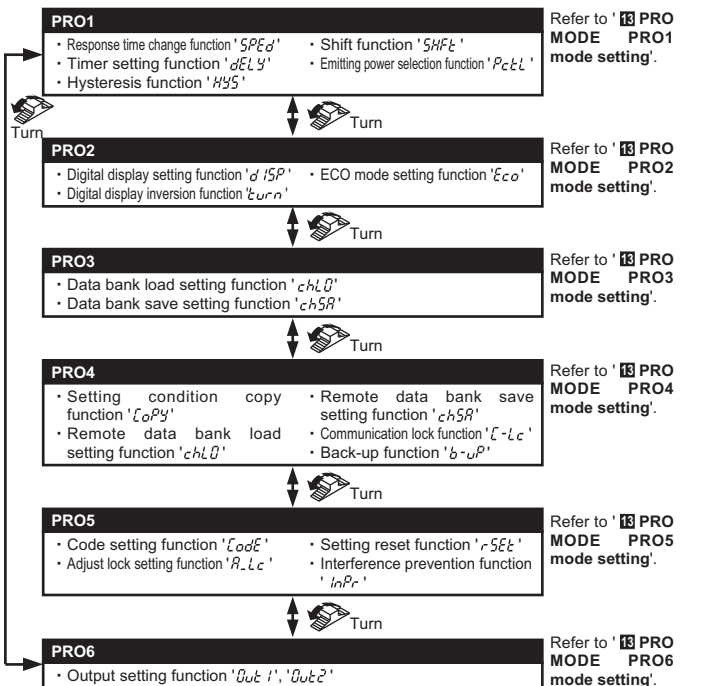

The 0-ADJ setting function in this product was removed from production starting May, 2005.

8 TEACHING MODE

In case of teaching in the window comparator mode, set the detailed settings in PRO6 beforehand. For the settings, refer to 'PRO MODE · PRO6 mode setting'.

In case of 2-level teaching

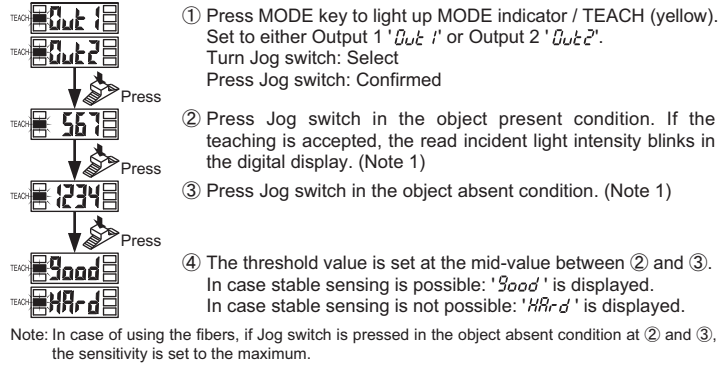

In case of limit teaching

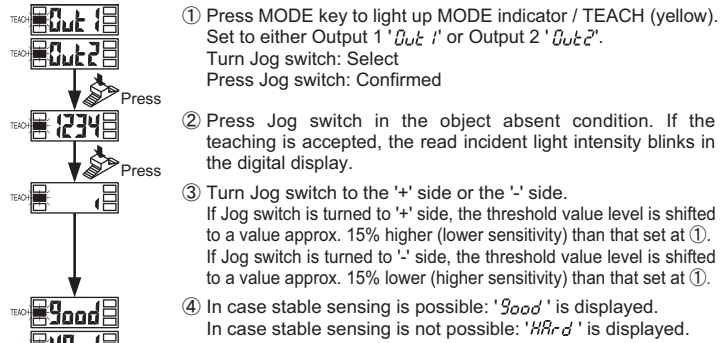

Note: The approx. 15% amount of shift is the initial value. The amount of shift can be changed in the PRO mode from approx. 0 to 80% (5% step). For the setting method refer to 'PRO MODE · PRO1 mode setting'.

In case of full-auto teaching

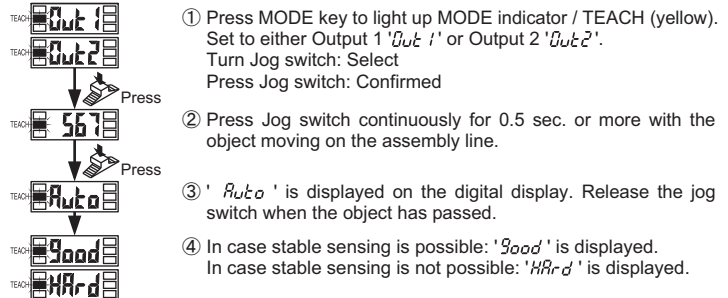

In case of window comparator mode / 1-level teaching

- This is the method of setting the threshold range by 1-level teaching. The shift value can be set as desired.

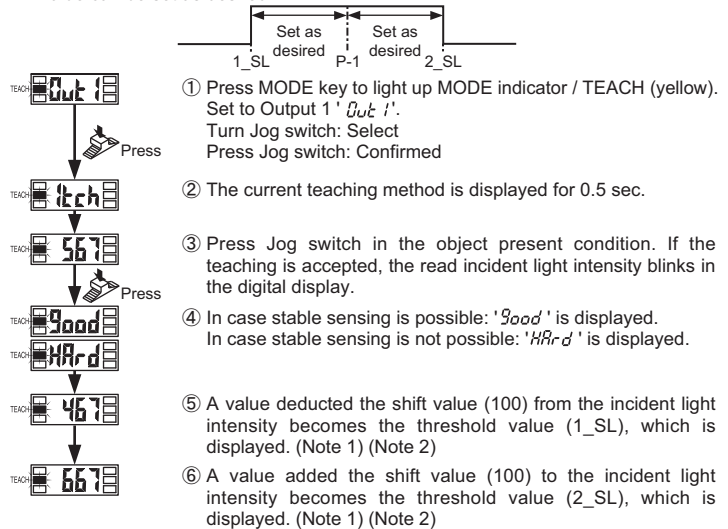

Notes: 1) The shift value 100 digits is the initial value. The shift value can be changed in PRO mode. Furthermore, 'digit' or 'percent' can be selected. For the setting method refer to 'PRO MODE · PRO6 mode setting'. 2) In case the set value exceeds the max. (min.) sensitivity, the set value is fixed at max. (min.) sensitivity.

In case of window comparator mode / 2-level teaching

- This is a method of setting the threshold range by two levels (P-1, P-2) teaching.

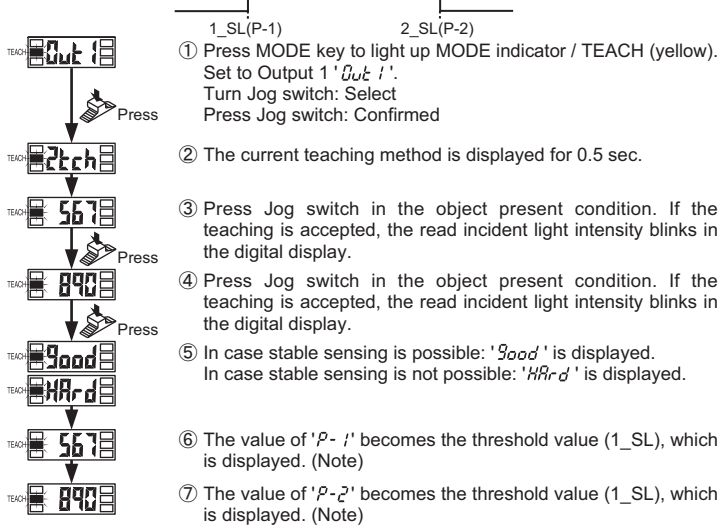

Note: In case the set value exceeds the max. (min.) sensitivity, the set value is fixed at max. (min.) sensitivity.

In case of window comparator mode / 3-level teaching

- This is a method of setting the threshold range by three levels (P-1, P-2, P-3) teaching and set the threshold values at the middle of 'A' and 'B' (1_SL) and 'B' and 'C' (2_SL) as per the diagram below.
- After teaching, P-1, P-2 and P-3 are automatically assigned in ascending order to 'A', 'B', and 'C'.

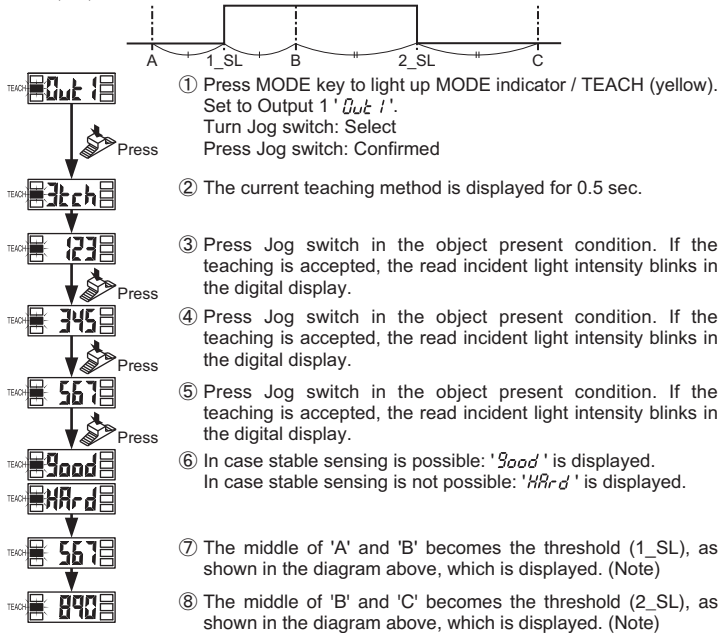

Note: In case the set value exceeds the max. (min.) sensitivity, the set value is fixed at max. (min.) sensitivity.

9 THRESHOLD VALUE FINE ADJUSTMENT MODE

- Fine adjustment of the threshold value can be done when MODE indicator / ADJ (yellow) lights up.
- Turn Jog switch to select either the output 1 'Out 1' or the output 2 'Out 2' and press it to confirm.
- In case of the window comparator mode has been set, when the jog switch is pressed in the output 1 'Out 1', '1_SL' or '2_SL' is displayed. Turn the jog switch to select and press it to confirm.
- When Jog switch is turned to the '+' side, the threshold value increases (sensitivity decreases). When Jog switch is turned to the '-' side, the threshold value decreases (sensitivity increases). When Jog switch is pressed, the threshold value is confirmed.

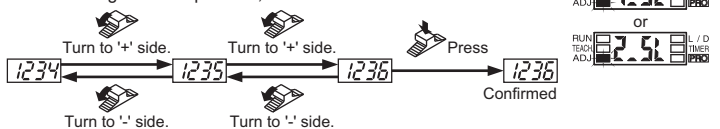

10 INTENDED PRODUCTS FOR CE MARKING

- The models listed under "SPECIFICATIONS" come with CE Marking. As for all other models, please contact our office.



Contact for CE

<Until June 30 ,2013>
Panasonic Electric Works Europe AG
Rudolf-Diesel-Ring 2, D-83607 Holzkirchen, Germany
<From July 1 ,2013>
Panasonic Marketing Europe GmbH Panasonic Testing Center
Winsbergring 15, 22525 Hamburg, Germany

11 OUTPUT OPERATION SETTING MODE

- The output operation setting can be done when MODE indicator / L/D ON (yellow) lights up.
- Turn Jog switch to select either the output 1 'Out 1' or the output 2 'Out 2' and press it to confirm.
- The output operation is changed when Jog switch is turned to the '+' side or the '-' side. When Jog switch is pressed, the threshold value is confirmed.

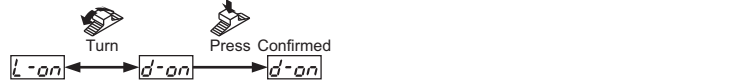

12 TIMER OPERATION SETTING MODE

- The setting for whether the timer is used or not can be done when MODE indicator / TIMER (yellow) lights up.
- Turn Jog switch to select either the output 1 'Out 1' or the output 2 'Out 2' and press it to confirm.
- The initial value of each timer function is 10ms.
- Refer to 'PRO MODE / PRO1 mode setting' for the setting method of the OFF-delay timer, ON-delay timer, ONE-SHOT timer, ON-delay · OFF-delay timer and ON-delay · ONE-SHOT timer intervals.

<In case of Output 1>

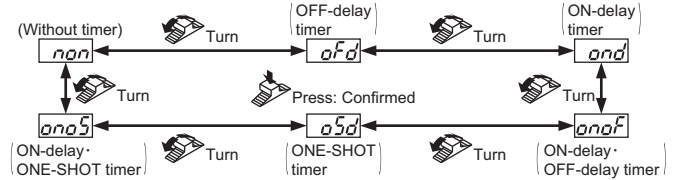

Notes: 1) The timer interval set in the PRO mode is displayed.
2) The factory setting is without timer 'non'.

<In case of Output 2>

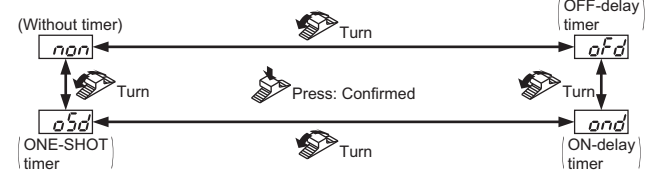

Notes: 1) The timer interval set in the PRO mode is displayed.
2) The factory setting is without timer 'non'.

13 PRO MODE

For details of the settings and the setting procedure of the PRO mode, refer to 'Panasonic Industrial Devices SUNX website (<http://panasonic.net/id/pidsx/global/>)' or contact our office.

- PRO settings can be done when MODE indicator / PRO (yellow) lights up.

PRO1 mode setting

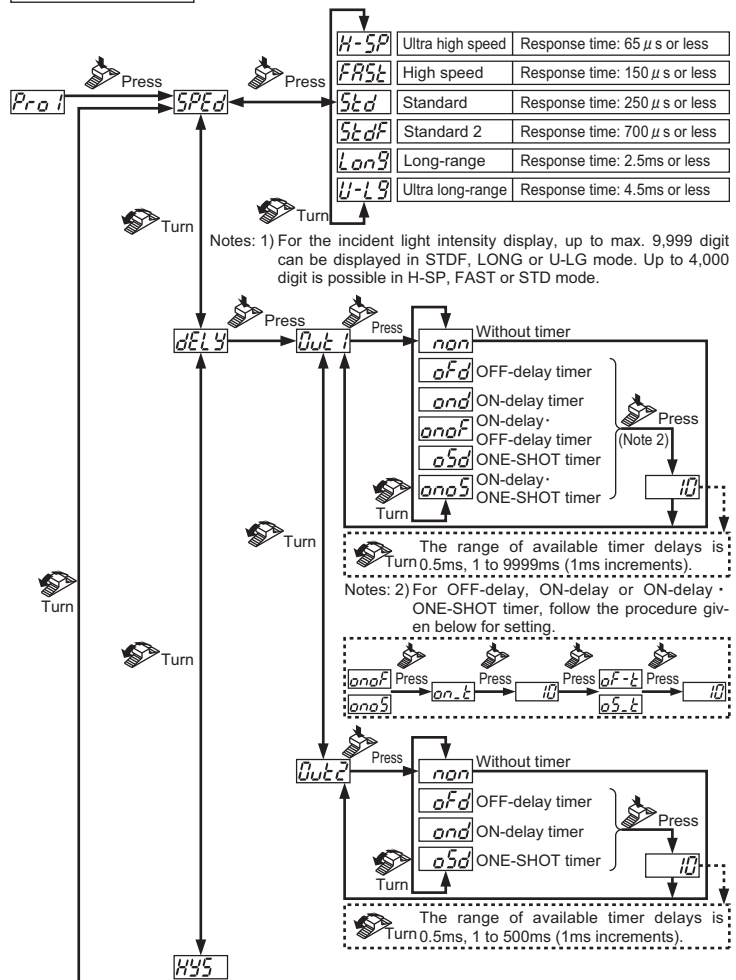

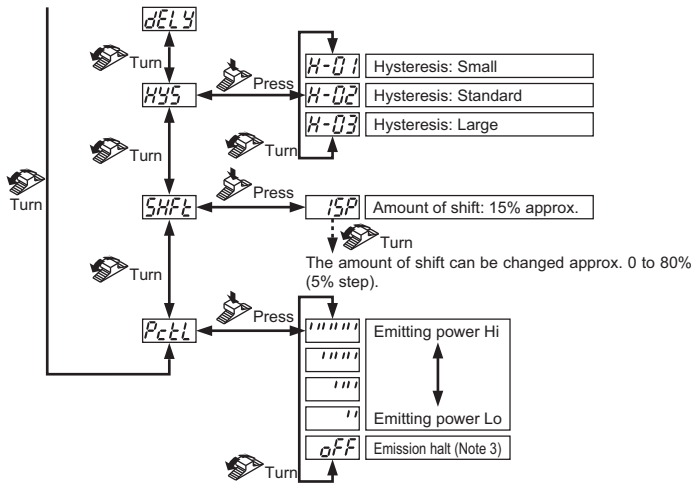

Notes: 3) If the sensor is returned to RUN state in the emitting halt condition, 'E.off' is displayed. The 'E.off' goes off when the emitting power is turned on.
 4) Only in the response time · H-SP mode, ON condition, the emitting power is 3 level.

PRO2 mode setting

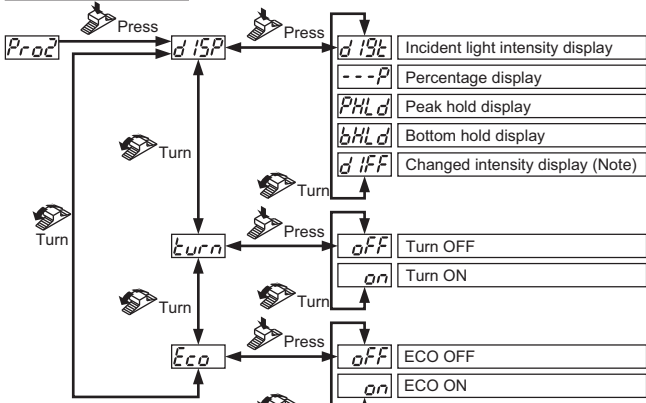

Note: When the differential mode 'd_f' or 'd_?' is set in PRO6 mode setting, the changed incident light intensity is displayed.

PRO3 mode setting

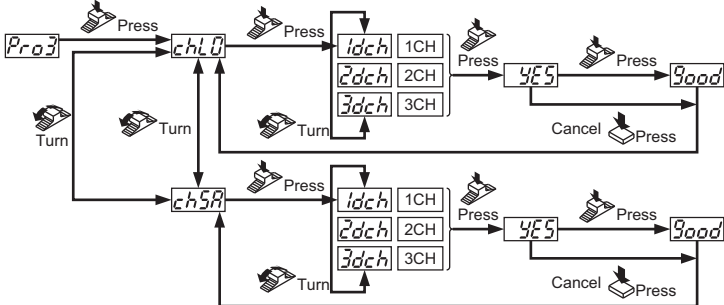

PRO4 mode setting

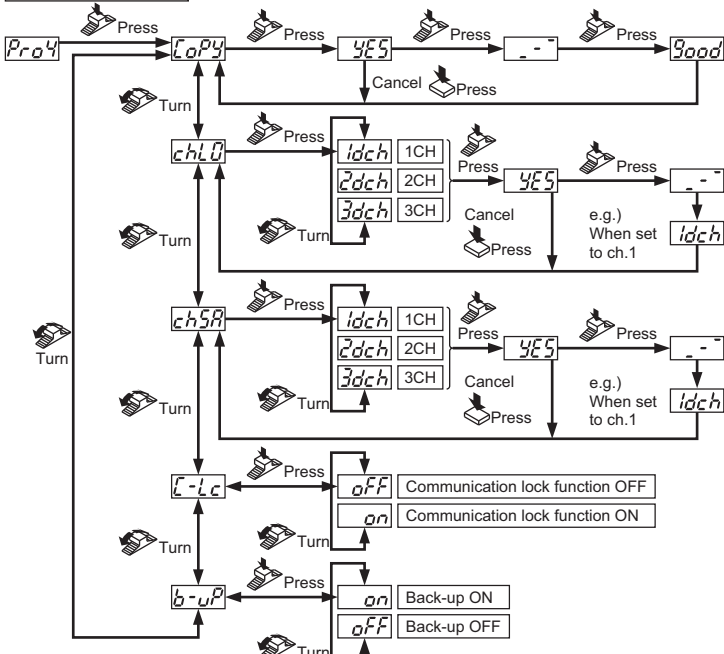

PRO5 mode setting

The 0-ADJ setting function in this product was removed from production starting May, 2005.

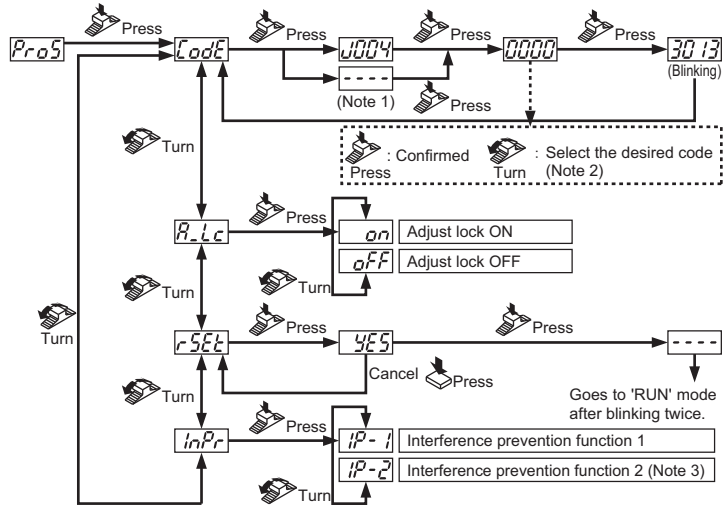

Notes: 1) When any code other than the codes given in the Code setting table below is used, '-' is displayed. The factory setting is '0004'.
 2) When the code setting function is used, refer to the 'Code setting table' given below. However, the code setting is only for the output 1.

Code setting table

1st figure	2nd figure	3rd figure	4th figure
Direct code	Response time	Hysteresis	Direct code
0	STD	H-02 (standard)	0
1	STD	H-03 (large)	1
2	STD	H-01 (small)	2
3	LONG	H-02 (standard)	3
4	LONG	H-03 (large)	4
5	LONG	H-01 (small)	5
6	FAST	H-02 (standard)	6
7	FAST	H-03 (large)	7
8	FAST	H-01 (small)	8
C	H-SP	H-02 (standard)	9
F	U-LG	H-02 (standard)	A
U	STDF	H-02 (standard)	b
			c
			d
			e

Legend: RUN (0-9), TEACH (C), ADJ (F, U), L/D TIMER (b, c, d, e)

3) When the interference prevention function 2 'IP-2' is set, the number of mountable fibers becomes double. Furthermore, take care that the response time also becomes double.
 4) In order to change PRO mode setting to 'RUN' mode, press MODE key for 2 sec. or more.

PRO6 mode setting

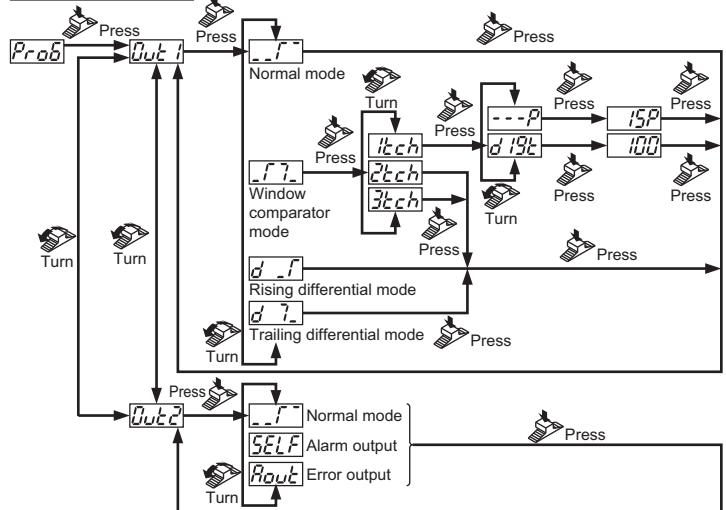

Note: When the differential mode is used, set the threshold value in the full-auto teaching. Furthermore, when the response time is used in STDF mode, LONG mode or U_LG mode, use the higher threshold value than that shown below.
 · STDF mode: 40 digits · LONG mode: 60 digits · U_LG mode: 100 digits

Panasonic Industrial Devices SUNX Co., Ltd.

<http://panasonic.net/id/pidsx/global>

Overseas Sales Division (Head Office)
 2431-1 Ushiyama-cho, Kasugai-shi, Aichi, 486-0901, Japan
 Phone: +81-568-33-7861 FAX: +81-568-33-8591

About our sale network, please visit our website.

PRINTED IN JAPAN

© Panasonic Industrial Devices SUNX Co., Ltd. 2012