

## USER'S MANUAL

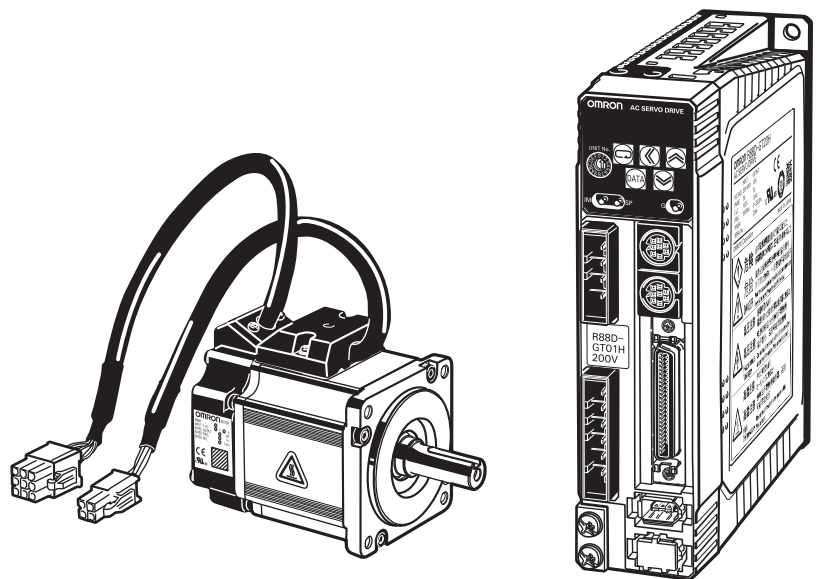

# OMNUC G SERIES

- R88M-G□  
(AC Servomotors)
- R88D-GT□  
(AC Servo Drives)

## AC SERVOMOTORS/SERVO DRIVES

#### Trademarks and Copyrights

- Product names and system names in this manual are trademarks or registered trademarks of their respective companies.

#### © OMRON, 2008

All rights reserved. No part of this publication may be reproduced, stored in a retrieval system, or transmitted, in any form, or by any means, mechanical, electronic, photocopying, recording, or otherwise, without the prior written permission of OMRON.

No patent liability is assumed with respect to the use of the information contained herein. Moreover, because OMRON is constantly striving to improve its high-quality products, the information contained in this manual is subject to change without notice. Every precaution has been taken in the preparation of this manual. Nevertheless, OMRON assumes no responsibility for errors or omissions. Neither is any liability assumed for damages resulting from the use of the information contained in this publication.

To: All Customers

October 2017

## AC SERVOMOTORS/SERVO DRIVES G-series

### Notification of additional sales of Decelerator (Model: R88G-VRXF)

OMRON Corporation

Cat. No. I562-E1-04

Thank you for using OMRON products.

Additional sales of the R88G-VRXF series (Backlash: 15 Arcminutes Max.) will be carried out. Production of the previous R88G-VRSF series is scheduled for termination, so please select the R88G-VRXF series.

The specifications of the R88G-VRXF series are as follows.

## Decelerator Model Tables

### 15 Arcminutes Max.

#### ● For 3,000-r/min Servomotors

Specifications		Model
servomotor capacity	Reduction ratio	
50 W	1/5	R88G-VRXF05B100CJ
	1/9	R88G-VRXF09B100CJ
	1/15	R88G-VRXF15B100CJ
	1/25	R88G-VRXF25B100CJ
100 W	1/5	R88G-VRXF05B100CJ
	1/9	R88G-VRXF09B100CJ
	1/15	R88G-VRXF15B100CJ
	1/25	R88G-VRXF25B100CJ
200 W	1/5	R88G-VRXF05B200CJ
	1/9	R88G-VRXF09C200CJ
	1/15	R88G-VRXF15C200CJ
	1/25	R88G-VRXF25C200CJ
400 W	1/5	R88G-VRXF05C400CJ
	1/9	R88G-VRXF09C400CJ
	1/15	R88G-VRXF15C400CJ
	1/25	R88G-VRXF25C400CJ
750 W	1/5	R88G-VRXF05C750CJ
	1/9	R88G-VRXF09D750CJ
	1/15	R88G-VRXF15D750CJ
	1/25	R88G-VRXF25D750CJ

● For 3,000-r/min Flat Servomotors

Specifications		Model
servomotor capacity	Reduction ratio	
100 W	1/5	R88G-VRXF05B100PCJ
	1/9	R88G-VRXF09B100PCJ
	1/15	R88G-VRXF15B100PCJ
	1/25	R88G-VRXF25B100PCJ
200 W	1/5	R88G-VRXF05B200PCJ
	1/9	R88G-VRXF09C200PCJ
	1/15	R88G-VRXF15C200PCJ
	1/25	R88G-VRXF25C200PCJ
400 W	1/5	R88G-VRXF05C400PCJ
	1/9	R88G-VRXF09C400PCJ
	1/15	R88G-VRXF15C400PCJ
	1/25	R88G-VRXF25C400PCJ

# Decelerator Dimensions

## 15 Arcminutes Max.

### ● For 3,000-r/min Servomotors

Model			Dimensions (mm)										
			LM	LR	C1	C2	D1	D2	D3	F	G	S	T
50W	1/5	R88G-VRXF05B100CJ	67.5	32	40	52	46	60	50	3	6	12	20
	1/9	R88G-VRXF09B100CJ	67.5	32	40	52	46	60	50	3	6	12	20
	1/15	R88G-VRXF15B100CJ	78.0	32	40	52	46	60	50	3	6	12	20
	1/25	R88G-VRXF25B100CJ	78.0	32	40	52	46	60	50	3	6	12	20
100W	1/5	R88G-VRXF05B100CJ	67.5	32	40	52	46	60	50	3	6	12	20
	1/9	R88G-VRXF09B100CJ	67.5	32	40	52	46	60	50	3	6	12	20
	1/15	R88G-VRXF15B100CJ	78.0	32	40	52	46	60	50	3	6	12	20
	1/25	R88G-VRXF25B100CJ	78.0	32	40	52	46	60	50	3	6	12	20
200W	1/5	R88G-VRXF05B200CJ	72.5	32	60	52	70	60	50	3	10	12	20
	1/9	R88G-VRXF09C200CJ	89.5	50	60	78	70	90	70	3	8	19	30
	1/15	R88G-VRXF15C200CJ	100.0	50	60	78	70	90	70	3	8	19	30
	1/25	R88G-VRXF25C200CJ	100.0	50	60	78	70	90	70	3	8	19	30
400W	1/5	R88G-VRXF05C400CJ	89.5	50	60	78	70	90	70	3	8	19	30
	1/9	R88G-VRXF09C400CJ	89.5	50	60	78	70	90	70	3	8	19	30
	1/15	R88G-VRXF15C400CJ	100.0	50	60	78	70	90	70	3	8	19	30
	1/25	R88G-VRXF25C400CJ	100.0	50	60	78	70	90	70	3	8	19	30
750W	1/5	R88G-VRXF05C750CJ	93.5	50	80	78	90	90	70	3	10	19	30
	1/9	R88G-VRXF09D750CJ	97.5	61	80	98	90	115	90	5	10	24	40
	1/15	R88G-VRXF15D750CJ	110.0	61	80	98	90	115	90	5	10	24	40
	1/25	R88G-VRXF25D750CJ	110.0	61	80	98	90	115	90	5	10	24	40

**Note 1.** The standard shaft type is a shaft with key and tap.

**Note 2.** The diameter of the motor shaft insertion hole is the same as the shaft diameter of the corresponding Servomotor.

**Note 3.** Applicable for the servomotors with key, if the key is removed.

**Note 4.** The dimensional drawings in this document are for showing main dimensions the details of the product shape.

### Outline Drawings

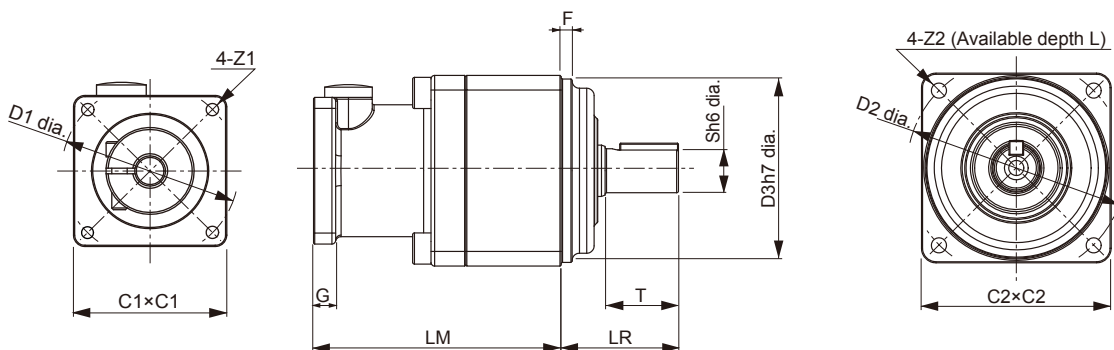

Model			Dimensions (mm)									
			Z1	Z2	AT	L	Key				Tap	
							QK	b	h	t1	m	l
50W	1/5	R88G-VRXF05B100CJ	M4	M5	M4	12	16	4	4	2.5	M5	10
	1/9	R88G-VRXF09B100CJ	M4	M5	M4	12	16	4	4	2.5	M5	10
	1/15	R88G-VRXF15B100CJ	M4	M5	M4	12	16	4	4	2.5	M5	10
	1/25	R88G-VRXF25B100CJ	M4	M5	M4	12	16	4	4	2.5	M5	10
100W	1/5	R88G-VRXF05B100CJ	M4	M5	M4	12	16	4	4	2.5	M5	10
	1/9	R88G-VRXF09B100CJ	M4	M5	M4	12	16	4	4	2.5	M5	10
	1/15	R88G-VRXF15B100CJ	M4	M5	M4	12	16	4	4	2.5	M5	10
	1/25	R88G-VRXF25B100CJ	M4	M5	M4	12	16	4	4	2.5	M5	10
200W	1/5	R88G-VRXF05B200CJ	M4	M5	M4	12	16	4	4	2.5	M5	10
	1/9	R88G-VRXF09C200CJ	M4	M6	M5	20	22	6	6	3.5	M6	12
	1/15	R88G-VRXF15C200CJ	M4	M6	M5	20	22	6	6	3.5	M6	12
	1/25	R88G-VRXF25C200CJ	M4	M6	M5	20	22	6	6	3.5	M6	12
400W	1/5	R88G-VRXF05C400CJ	M4	M6	M5	20	22	6	6	3.5	M6	12
	1/9	R88G-VRXF09C400CJ	M4	M6	M5	20	22	6	6	3.5	M6	12
	1/15	R88G-VRXF15C400CJ	M4	M6	M5	20	22	6	6	3.5	M6	12
	1/25	R88G-VRXF25C400CJ	M4	M6	M5	20	22	6	6	3.5	M6	12
750W	1/5	R88G-VRXF05C750CJ	M5	M6	M6	20	22	6	6	3.5	M6	12
	1/9	R88G-VRXF09D750CJ	M5	M8	M6	20	30	8	7	4	M8	16
	1/15	R88G-VRXF15D750CJ	M5	M8	M6	20	30	8	7	4	M8	16
	1/25	R88G-VRXF25D750CJ	M5	M8	M6	20	30	8	7	4	M8	16

### Outline Drawings

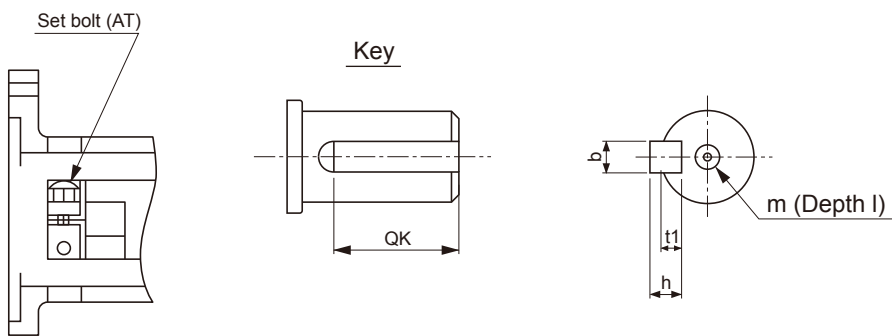

● For 3,000-r/min Flat Servomotors

Model			Dimensions (mm)										
			LM	LR	C1	C2	D1	D2	D3	F	G	S	T
100W	1/5	R88G-VRXF05B100PCJ	67.5	32	60	52	70	60	50	3	15.5	12	20
	1/9	R88G-VRXF09B100PCJ	67.5	32	60	52	70	60	50	3	15.5	12	20
	1/15	R88G-VRXF15B100PCJ	83.5	32	60	52	70	60	50	3	15.5	12	20
	1/25	R88G-VRXF25B100PCJ	83.5	32	60	52	70	60	50	3	15.5	12	20
200W	1/5	R88G-VRXF05B200PCJ	77.5	32	80	52	90	60	50	3	21.5	12	20
	1/9	R88G-VRXF09C200PCJ	94.5	50	80	78	90	90	70	3	21.5	19	30
	1/15	R88G-VRXF15C200PCJ	105.0	50	80	78	90	90	70	3	21.5	19	30
	1/25	R88G-VRXF25C200PCJ	105.0	50	80	78	90	90	70	3	21.5	19	30
400W	1/5	R88G-VRXF05C400PCJ	94.5	50	80	78	90	90	70	3	21.5	19	30
	1/9	R88G-VRXF09C400PCJ	94.5	50	80	78	90	90	70	3	21.5	19	30
	1/15	R88G-VRXF15C400PCJ	105.0	50	80	78	90	90	70	3	21.5	19	30
	1/25	R88G-VRXF25C400PCJ	105.0	50	80	78	90	90	70	3	21.5	19	30

**Note 1.** The standard shaft type is a shaft with key and tap.

**Note 2.** The diameter of the motor shaft insertion hole is the same as the shaft diameter of the corresponding Servomotor.

**Note 3.** Applicable for the servomotors with key, if the key is removed.

**Note 4.** The dimensional drawings in this document are for showing main dimensions the details of the product shape.

**Outline Drawings**

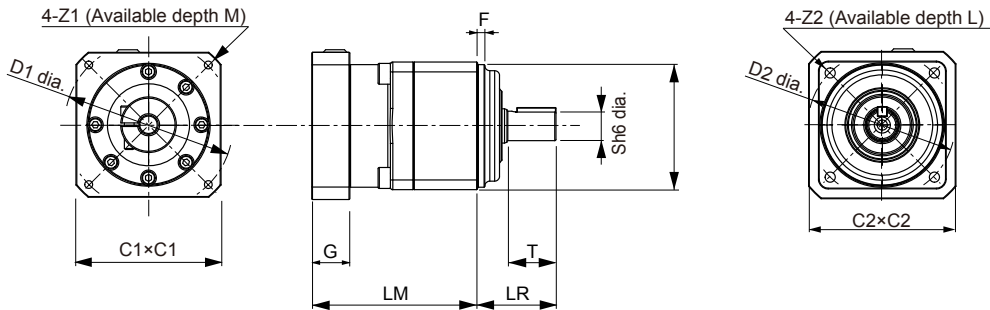

Model			Dimensions (mm)										
			Z1	Z2	AT	M	L	Key				Tap	
								QK	b	h	t1	m	l
100 W	1/5	R88G-VRXF05B100PCJ	M4	M5	M4	9	12	16	4	4	2.5	M5	10
	1/9	R88G-VRXF09B100PCJ	M4	M5	M4	9	12	16	4	4	2.5	M5	10
	1/15	R88G-VRXF15B100PCJ	M4	M5	M4	9	12	16	4	4	2.5	M5	10
	1/25	R88G-VRXF25B100PCJ	M4	M5	M4	9	12	16	4	4	2.5	M5	10
200 W	1/5	R88G-VRXF05B200PCJ	M5	M5	M4	11	12	16	4	4	2.5	M5	10
	1/9	R88G-VRXF09C200PCJ	M5	M6	M5	11	20	22	6	6	3.5	M6	12
	1/15	R88G-VRXF15C200PCJ	M5	M6	M5	11	20	22	6	6	3.5	M6	12
	1/25	R88G-VRXF25C200PCJ	M5	M6	M5	11	20	22	6	6	3.5	M6	12
400 W	1/5	R88G-VRXF05C400PCJ	M5	M6	M5	11	20	22	6	6	3.5	M6	12
	1/9	R88G-VRXF09C400PCJ	M5	M6	M5	11	20	22	6	6	3.5	M6	12
	1/15	R88G-VRXF15C400PCJ	M5	M6	M5	11	20	22	6	6	3.5	M6	12
	1/25	R88G-VRXF25C400PCJ	M5	M6	M5	11	20	22	6	6	3.5	M6	12

### Outline Drawings

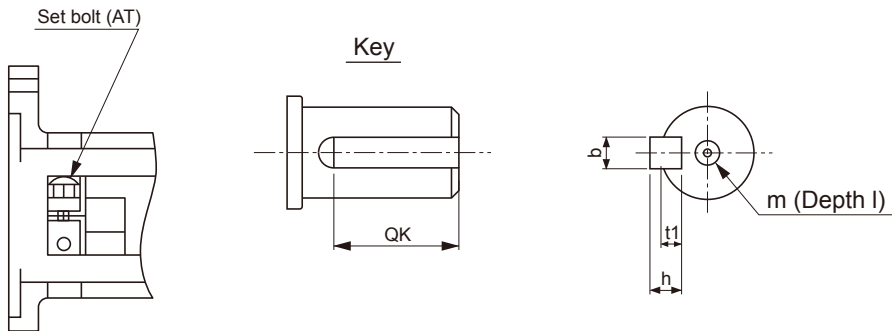



# Models and Specifications

## 15 Arcminutes Max.

### ● For 3,000-r/min Servomotors

Model		Rated rotation speed	Rated torque	Efficiency	Maximum momentary rotation speed	Maximum momentary torque	Decelerator inertia	Allowable radial load	Allowable thrust load	Weight	
		r/min	N·m	%	r/min	N·m	kg·m <sup>2</sup>	N	N	kg	
50 W	1/5	R88G-VRXF05B100CJ	600	0.66	82	1000	1.85	6.04×10 <sup>-6</sup>	392	196	0.55
	1/9	R88G-VRXF09B100CJ	333	1.18	82	556	3.32	4.97×10 <sup>-6</sup>	441	220	0.55
	1/15	R88G-VRXF15B100CJ	200	1.85	77	333	5.20	5.26×10 <sup>-6</sup>	588	294	0.70
	1/25	R88G-VRXF25B100CJ	120	3.08	77	200	8.66	5.14×10 <sup>-6</sup>	686	343	0.70
100 W	1/5	R88G-VRXF05B100CJ	600	1.44	90	1000	4.05 (4.19)	6.04×10 <sup>-6</sup>	392	196	0.55
	1/9	R88G-VRXF09B100CJ	333	2.59	90	556	7.29 (7.53)	4.97×10 <sup>-6</sup>	441	220	0.55
	1/15	R88G-VRXF15B100CJ	200	4.13	86	333	11.61 (12.00)	5.26×10 <sup>-6</sup>	588	294	0.70
	1/25	R88G-VRXF25B100CJ	120	6.88	86	200	19.35 (20.00)	5.14×10 <sup>-6</sup>	686	343	0.70
200 W	1/5	R88G-VRXF05B200CJ	600	2.94	92	1000	8.19	1.47×10 <sup>-5</sup>	392	196	0.72
	1/9	R88G-VRXF09C200CJ	333	4.78	83	556	13.30	2.37×10 <sup>-5</sup>	931	465	1.70
	1/15	R88G-VRXF15C200CJ	200	8.26	86	333	22.96	3.02×10 <sup>-5</sup>	1176	588	2.10
	1/25	R88G-VRXF25C200CJ	120	13.76	86	200	38.27	2.93×10 <sup>-5</sup>	1323	661	2.10
400 W	1/5	R88G-VRXF05C400CJ	600	5.72	88	1000	16.15 (15.84)	3.7×10 <sup>-5</sup>	784	392	1.70
	1/9	R88G-VRXF09C400CJ	333	10.30	88	556	29.07 (28.51)	2.37×10 <sup>-5</sup>	931	465	1.70
	1/15	R88G-VRXF15C400CJ	200	17.36	89	333	48.99 (48.06)	3.02×10 <sup>-5</sup>	1176	588	2.10
	1/25	R88G-VRXF25C400CJ	120	28.93	89	200	81.66 (80.10)	2.93×10 <sup>-5</sup>	1323	661	2.10
750 W	1/5	R88G-VRXF05C750CJ	600	11.04	92	900	32.43	8.17×10 <sup>-5</sup>	784	392	2.10
	1/9	R88G-VRXF09D750CJ	333	19.66	91	500	57.74	7.55×10 <sup>-5</sup>	1176	588	3.40
	1/15	R88G-VRXF15D750CJ	200	32.04	89	300	94.12	6.86×10 <sup>-5</sup>	1372	686	3.80
	1/25	R88G-VRXF25D750CJ	120	53.40	89	180	156.86	6.58×10 <sup>-5</sup>	1617	808	3.80

**Note 1.** The values inside parentheses ( ) are for 100-V Servomotors.

**Note 2.** The Decelerator inertia is the Servomotor shaft conversion value.

**Note 3.** The protective structure rating of the Servomotor combined with the Decelerator is IP44. (Excluding decelerator and servo motor connecting parts.)

**Note 4.** The allowable radial load is the value at the T/2 position.

**Note 5.** The standard models have a straight shaft with key and tap. (The key is temporarily assembled to the shaft.)

**Note 6.** Take care so that the surface temperature of the Decelerator does not exceed 90°C.

● For 3,000-r/min Flat Servomotors

Model			Rated rotation speed	Rated torque	Efficiency	Maximum momentary rotation speed	Maximum momentary torque	Decelerator inertia	Allowable radial load	Allowable thrust load	Weight
			r/min	N·m	%	r/min	N·m	kg·m <sup>2</sup>	N	N	kg
100 W	1/5	R88G-VRXF05B100PCJ	600	1.44	90	1000	3.87 (3.78)	6.00×10 <sup>-6</sup>	392	196	0.70
	1/9	R88G-VRXF09B100PCJ	333	2.59	90	556	6.97 (6.80)	5.00×10 <sup>-6</sup>	441	220	0.70
	1/15	R88G-VRXF15B100PCJ	200	4.13	86	333	11.09 (10.84)	5.70×10 <sup>-6</sup>	588	294	0.90
	1/25	R88G-VRXF25B100PCJ	120	6.88	86	200	18.49 (18.06)	5.50×10 <sup>-6</sup>	686	343	0.90
200 W	1/5	R88G-VRXF05B200PCJ	600	2.94	92	1000	8.28	1.50×10 <sup>-5</sup>	392	196	0.90
	1/9	R88G-VRXF09C200PCJ	333	4.78	83	556	13.45	2.70×10 <sup>-5</sup>	931	465	2.00
	1/15	R88G-VRXF15C200PCJ	200	8.26	86	333	23.22	3.00×10 <sup>-5</sup>	1176	588	2.40
	1/25	R88G-VRXF25C200PCJ	120	13.76	86	200	38.70	2.90×10 <sup>-5</sup>	1323	661	2.40
400 W	1/5	R88G-VRXF05C400PCJ	600	5.72	88	1000 (900)	16.06 (15.84)	3.70×10 <sup>-5</sup>	784	392	2.00
	1/9	R88G-VRXF09C400PCJ	333	10.30	88	556 (500)	28.91 (28.51)	2.70×10 <sup>-5</sup>	931	465	2.00
	1/15	R88G-VRXF15C400PCJ	200	17.36	89	333 (300)	48.73 (48.06)	3.00×10 <sup>-5</sup>	1176	588	2.40
	1/25	R88G-VRXF25C400PCJ	120	28.93	89	200 (180)	81.21 (80.10)	2.90×10 <sup>-5</sup>	1323	661	2.40

**Note 1.** The values inside parentheses ( ) are for 100-V Servomotors.

**Note 2.** The Decelerator inertia is the Servomotor shaft conversion value.

**Note 3.** The protective structure rating of the Servomotor combined with the Decelerator is IP44. (Excluding decelerator and servo motor connecting parts.)

**Note 4.** The allowable radial load is the value at the T/2 position.

**Note 5.** The standard models have a straight shaft with key and tap. (The key is temporarily assembled to the shaft.)

**Note 6.** Take care so that the surface temperature of the Decelerator does not exceed 90°C.

# Decelerator Installation Conditions

## Installing the R88G-VRXF□□□ (15 Arcminutes Type)

Follow the instructions bellow for installing this Decelerator and the Servomotor.

- 1 Turn the input joint and align the head of the bolt that secures the shaft with the cap.  
Check that the set bolt is loose.

- 2 Gently insert the Servomotor into the Decelerator.

Put up the decelerator vertically and slide the Servomotor into the input shaft joint while using the motor shaft as guide not to fall over, as shown in the figures on the next page. When the Decelerator cannot be put up vertically, tighten each bolt evenly little by little to ensure that the Servomotor is not inserted at a tilt.

- 3 Fix the Servomotor and the flange of the Decelerator with bolts.

Bolt tightening torque

Allen head bolt size	M4	M5
Tightening torque [N·m]	2.5	5.1

- 4 Tighten the bolts of the input joint.

Bolt tightening torque (for duralumin)

Allen head bolt size	M4	M5	M6
Tightening torque [N·m]	4.3	8.7	15

**Note** Tighten the bolts to the torque indicated on the above table. A problem such as slipping may occur if the specified torque level is not satisfied.

- 5 Mount the supplied cap to complete the installation.

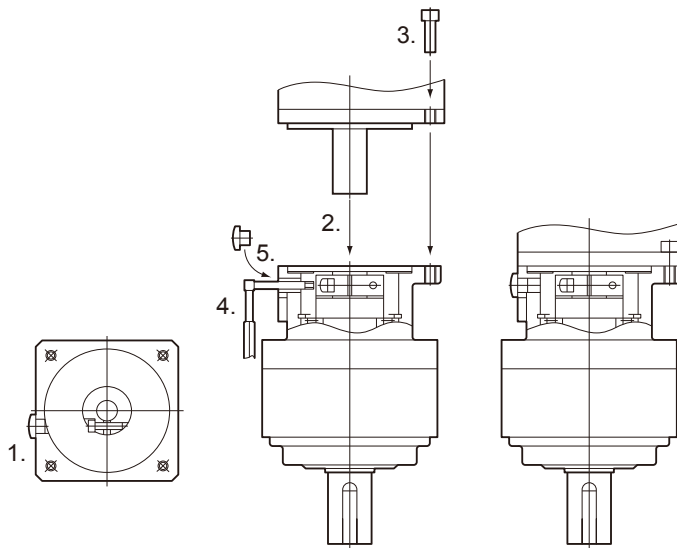

### ● Installing Decelerator into the Machine

When you install the R88G-VRXF□□□ into the machine, confirm that the mounting surface is flat and there are no burrs on the tap sections, and fix the mounting flange with bolts.

Bolt tightening torque on the mounting flange (for aluminum)

R88G-VRXF	B	C	D
Number of bolts	4	4	4
Size of bolts	M5	M6	M8
Mounting PCD [mm]	60	90	115
Tightening torque [N·m]	5.8	9.8	19.6

**Note** If the key on a Servomotor with key is uninstalled, it is possible to use the Decelerator by installing the Servomotor without above mentioned key.  
Slipping does not occur.



---

---

# Introduction

---

Thank you for choosing the OMNUC G Series. This User's Manual describes installation/wiring methods and parameter setting procedures required for the operation of the OMNUC G Series as well as troubleshooting and inspection methods.

## Intended Readers

This manual is intended for the following personnel.  
Those with knowledge of electrical systems (a qualified electrical engineer or the equivalent) as follows:

- Personnel in charge of introducing FA equipment
- Personnel in charge of designing FA systems
- Personnel in charge of managing FA systems and facilities

## NOTICE

This manual contains information necessary to ensure safe and proper use of the OMNUC G Series and its peripheral devices. Please read this manual thoroughly and understand its contents before using the products.

Please keep this manual handy for future reference.

Make sure this User's Manual is delivered to the actual end user of the products.

---

---

# Terms and Conditions Agreement

---

## Warranty, Limitations of Liability

### ■ Warranties

#### ● Exclusive Warranty

Omron's exclusive warranty is that the Products will be free from defects in materials and workmanship for a period of twelve months from the date of sale by Omron (or such other period expressed in writing by Omron). Omron disclaims all other warranties, express or implied.

#### ● Limitations

OMRON MAKES NO WARRANTY OR REPRESENTATION, EXPRESS OR IMPLIED, ABOUT NON-INFRINGEMENT, MERCHANTABILITY OR FITNESS FOR A PARTICULAR PURPOSE OF THE PRODUCTS. BUYER ACKNOWLEDGES THAT IT ALONE HAS DETERMINED THAT THE PRODUCTS WILL SUITABLY MEET THE REQUIREMENTS OF THEIR INTENDED USE.

Omron further disclaims all warranties and responsibility of any type for claims or expenses based on infringement by the Products or otherwise of any intellectual property right.

#### ● Buyer Remedy

Omron's sole obligation hereunder shall be, at Omron's election, to (i) replace (in the form originally shipped with Buyer responsible for labor charges for removal or replacement thereof) the non-complying Product, (ii) repair the non-complying Product, or (iii) repay or credit Buyer an amount equal to the purchase price of the non-complying Product; provided that in no event shall Omron be responsible for warranty, repair, indemnity or any other claims or expenses regarding the Products unless Omron's analysis confirms that the Products were properly handled, stored, installed and maintained and not subject to contamination, abuse, misuse or inappropriate modification. Return of any Products by Buyer must be approved in writing by Omron before shipment. Omron Companies shall not be liable for the suitability or unsuitability or the results from the use of Products in combination with any electrical or electronic components, circuits, system assemblies or any other materials or substances or environments. Any advice, recommendations or information given orally or in writing, are not to be construed as an amendment or addition to the above warranty.

See <http://www.omron.com/global/> or contact your Omron representative for published information.

### ■ Limitation on Liability; Etc

OMRON COMPANIES SHALL NOT BE LIABLE FOR SPECIAL, INDIRECT, INCIDENTAL, OR CONSEQUENTIAL DAMAGES, LOSS OF PROFITS OR PRODUCTION OR COMMERCIAL LOSS IN ANY WAY CONNECTED WITH THE PRODUCTS, WHETHER SUCH CLAIM IS BASED IN CONTRACT, WARRANTY, NEGLIGENCE OR STRICT LIABILITY.

Further, in no event shall liability of Omron Companies exceed the individual price of the Product on which liability is asserted.

## Application Considerations

### ■ Suitability of Use

Omron Companies shall not be responsible for conformity with any standards, codes or regulations which apply to the combination of the Product in the Buyer's application or use of the Product. At Buyer's request, Omron will provide applicable third party certification documents identifying ratings and limitations of use which apply to the Product. This information by itself is not sufficient for a complete determination of the suitability of the Product in combination with the end product, machine, system, or other application or use. Buyer shall be solely responsible for determining appropriateness of the particular Product with respect to Buyer's application, product or system. Buyer shall take application responsibility in all cases.

NEVER USE THE PRODUCT FOR AN APPLICATION INVOLVING SERIOUS RISK TO LIFE OR PROPERTY WITHOUT ENSURING THAT THE SYSTEM AS A WHOLE HAS BEEN DESIGNED TO ADDRESS THE RISKS, AND THAT THE OMRON PRODUCT(S) IS PROPERLY RATED AND INSTALLED FOR THE INTENDED USE WITHIN THE OVERALL EQUIPMENT OR SYSTEM.

### ■ Programmable Products

Omron Companies shall not be responsible for the user's programming of a programmable Product, or any consequence thereof.

## Disclaimers

### ■ Performance Data

Data presented in Omron Company websites, catalogs and other materials is provided as a guide for the user in determining suitability and does not constitute a warranty. It may represent the result of Omron's test conditions, and the user must correlate it to actual application requirements. Actual performance is subject to the Omron's Warranty and Limitations of Liability.

### ■ Change in Specifications

Product specifications and accessories may be changed at any time based on improvements and other reasons. It is our practice to change part numbers when published ratings or features are changed, or when significant construction changes are made. However, some specifications of the Product may be changed without any notice. When in doubt, special part numbers may be assigned to fix or establish key specifications for your application. Please consult with your Omron's representative at any time to confirm actual specifications of purchased Product.

### ■ Errors and Omissions

Information presented by Omron Companies has been checked and is believed to be accurate; however, no responsibility is assumed for clerical, typographical or proofreading errors or omissions.

---

---



# Precautions for Safe Use

---

- To ensure safe and proper use of the OMNUC G Series and its peripheral devices, read the “Precautions for Safe Use” and the rest of the manual thoroughly to acquire sufficient knowledge of the devices, safety information, and precautions before using the products.
- Make sure this User’s Manual is delivered to the actual end users of the products.
- Please keep this manual close at hand for future reference.

## Explanation of Signal Words





- The precautions indicated here provide important information for safety. Be sure to heed the information provided with the precautions.
- The following signal words are used to indicate and classify precautions in this manual.

 <b>WARNING</b>	Indicates a potentially hazardous situation which, if not avoided, could result in death or serious injury. Additionally, there may be severe property damage.
 <b>Caution</b>	Indicates a potentially hazardous situation which, if not avoided, may result in minor or moderate injury, or property damage.











Failure to heed the precautions classified as “Caution” may also lead to serious results. Always heed these precautions.

## Safety Precautions

- This manual may include illustrations of the product with protective covers or shields removed in order to show the components of the product in detail. Make sure that these protective covers and shields are put in place as specified before using the product.
- Consult your OMRON representative when using the product after a long period of storage.

 <b>WARNING</b>	
	Always connect the frame ground terminals of the Servo Drive and the Servomotor to 100 Ω or less. Incorrect grounding may result in electric shock.
	Do not touch the inside of the Servo Drive. Doing so may result in electric shock.
	When turning OFF the main circuit power supply, turn OFF the RUN Command Input (RUN) at the same time. Residual voltage may cause the Servomotor to continue rotating and result in injury or equipment damage even if the main circuit power supply is turned OFF externally, e.g., with an emergency stop.
	Do not remove the front cover, terminal covers, cables, or optional items while the power is being supplied. Doing so may result in electric shock.



	Installation, operation, maintenance, or inspection must be performed by authorized personnel. Not doing so may result in electric shock or injury.
	Wiring or inspection must not be performed for at least 15 minutes after turning OFF the power supply. Doing so may result in electric shock.
	Do not damage or pull on the cables, place heavy objects on them, or subject them to excessive stress. Doing so may result in electric shock, stopping product operation, or burning.
	Do not touch the rotating parts of the Servomotor during operation. Doing so may result in injury.
	Do not modify the product. Doing so may result in injury or damage to the product.
	Provide a stopping mechanism on the machine to ensure safety. *The holding brake is not designed as a stopping mechanism for safety purposes. Not doing so may result in injury.
	Provide an external emergency stopping mechanism that can stop operation and shut off the power supply immediately. Not doing so may result in injury.
	Do not come close to the machine immediately after resetting momentary power interruption to avoid an unexpected restart. Doing so may result in injury. Take appropriate measures to secure safety against an unexpected restart.
	Confirm safety after an earthquake has occurred. Failure to do so may result in electric shock, injury, or fire.
	Do not use external force to drive the Servomotor. Doing so may result in fire.

## Precautions for Safe Use



### WARNING



Do not place any flammable materials near the Servomotor, Servo Drive, or Regeneration Resistor. Doing so may result in fire.



Mount the Servomotor, Servo Drive, and Regeneration Resistor on metal or other non-flammable materials. Failure to do so may result in fire.



Do not frequently and repeatedly turn the main power supply ON and OFF. Doing so may result in product failure.



### Caution



Use the Servomotors and Servo Drives in a specified combination. Using them incorrectly may result in fire or damage to the products.



Do not store or install the product in the following places. Doing so may result in fire, electric shock, or damage to the product.

- Locations subject to direct sunlight.
- Locations subject to temperatures outside the specified range.
- Locations subject to humidity outside the specified range.
- Locations subject to condensation as the result of severe changes in temperature.
- Locations subject to corrosive or flammable gases.
- Locations subject to dust (especially iron dust) or salts.
- Locations subject to exposure to water, oil, or chemicals.
- Locations subject to shock or vibration.



Do not touch the Servo Drive radiator, Servo Drive regeneration resistor, or Servomotor while the power is being supplied or soon after the power is turned OFF. Doing so may result in burn injuries.

## ■ Storage and Transportation Precautions



### Caution



Do not hold the product by the cables or motor shaft while transporting it. Doing so may result in injury or malfunction.

















Do not place any load exceeding the figure indicated on the product. Doing so may result in injury or malfunction.











Use the motor eye-bolts only for transporting the Servomotor. Using them for transporting the machinery may result in injury or malfunction.

■ Installation and Wiring Precautions



 <h1 style="margin: 0;">Caution</h1>	
	Do not step on or place a heavy object on the product. Doing so may result in injury.
	Do not cover the inlet or outlet ports and prevent any foreign objects from entering the product. Covering them or not preventing entry of foreign objects may result in fire.
	Be sure to install the product in the correct direction. Not doing so may result in malfunction.
	Provide the specified clearances between the Servo Drive and the control panel or with other devices. Not doing so may result in fire or malfunction.
	Do not subject Servomotor shaft or Servo Drive to strong impacts. Doing so may result in malfunction.
	Be sure to wire correctly and securely. Not doing so may result in motor runaway, injury, or malfunction.
	Be sure that all the mounting screws, terminal screws, and cable connector screws are tightened properly. Incorrect tightening torque may result in malfunction.
	Use crimp terminals for wiring. Do not connect bare stranded wires directly to the protective ground terminal. Doing so may result in burning.
	Always use the power supply voltage specified in the User's Manual. An incorrect voltage may result in malfunction or burning.
	Take appropriate measures to ensure that the specified power with the rated voltage and frequency is supplied. Be particularly careful in places where the power supply is unstable. An incorrect power supply may result in equipment damage.
	Install external breakers and take other safety measures against short-circuiting in external wiring. Insufficient safety measures against short-circuiting may result in burning.
	Take appropriate and sufficient shielding measures when installing systems in the following locations. Failure to do so may result in damage to the product. <ul style="list-style-type: none"> <li>• Locations subject to static electricity or other forms of noise.</li> <li>• Locations subject to strong electromagnetic fields and magnetic fields.</li> <li>• Locations subject to possible exposure to radioactivity.</li> <li>• Locations close to power supplies.</li> </ul>
	Connect an emergency stop cutoff relay in series with the brake control relay. Failure to do so may result in injury or product failure.
	Do not reverse the polarity of the battery when connecting it. Reversing the polarity may damage the battery or cause it to explode.

## Precautions for Safe Use

### ■ Operation and Adjustment Precautions

 <b>Caution</b>	
	Confirm that no adverse effects will occur in the system before performing the test operation. Not doing so may result in equipment damage.
	Check the newly set parameters for proper operation before actually running them. Not doing so may result in equipment damage.
	Do not make any extreme adjustments or setting changes. Doing so may result in unstable operation and injury.
	Separate the Servomotor from the machine, check for proper operation, and then connect to the machine. Not doing so may cause injury.
	When an alarm occurs, remove the cause, reset the alarm after confirming safety, and then resume operation. Not doing so may result in injury.
	Do not use the built-in brake of the Servomotor for ordinary braking. Doing so may result in malfunction.
	Do not operate the Servomotor connected to a load that exceeds the applicable load moment of inertia. Doing so may result in malfunction.

### ■ Maintenance and Inspection Precautions

 <b>Caution</b>	
	Resume operation only after transferring to the new Unit the contents of the data required for operation. Not doing so may result in equipment damage.
	Do not attempt to disassemble or repair any of the products. Any attempt to do so may result in electric shock or injury.

■ Warning Label Position

Warning labels are located on the product as shown in the following illustration. Be sure to follow the instructions given there.

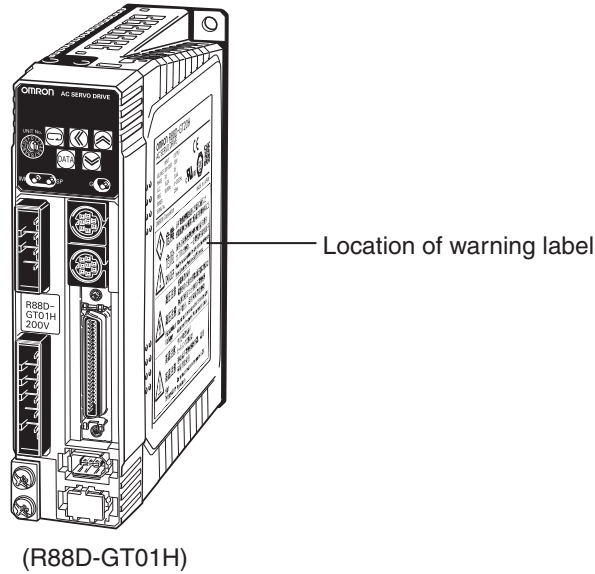

■ Warning Label Contents

	<p><b>危険</b> 必ず取扱説明書を読んで指示に従うこと 感電保護のため確実に⊕端子を接地すること</p> <p><b>危险</b> 请务必按照使用说明书的指示操作 为了防止触电，一定要接好接地端子</p> <p><b>DANGER</b> Read the manual and follow the safety instructions before use. Never fail to connect Protective Earth(PE) terminal.</p>
	<p><b>高压注意</b> 感電の恐れあり 電源を切った後15分間は端子部に触るな!</p> <p><b>高压注意</b> 电源切断后15分钟内不要触摸 端子部分，否则可能导致触电</p> <p><b>Hazardous Voltage</b> Do not touch terminals within 15 minutes after disconnect the power. Risk of electric shock.</p>
	<p><b>高温注意</b> やけどの恐れあり ヒートシンクに触るな!</p> <p><b>高温注意</b> 通电后不要触摸散热器，否则 可能导致受伤</p> <p><b>High Temperature</b> Do not touch heatsink when power is ON. Risk of burn.</p>

■ Disposing of the Product

- Dispose of the batteries according to local ordinances and regulations. Wrap the batteries in tape or other insulative material before disposing of them.
- Dispose of the product as industrial waste.

# Items to Check When Unpacking

Check the following items after removing the product from the package.

- Has the correct product been delivered?
- Has the product been damaged in shipping?

## ■ Accessories Provided with Product

**Safety Precautions document** × 1

- No connectors or mounting screws are provided. They have to be prepared by the user.
- Should you find any problems (missing parts, damage to the Servo Drive, etc.), please contact your local sales representative or OMRON sales office.

Specifications		Connector for main circuit power supply terminals and control circuit power supply terminals	Connector for External Regeneration Resistor connection terminals and Motor connection terminals	Mounting Brackets
Single-phase 100 VAC	50 W	Included		-
	100 W			
	200 W			
	400 W			
Single-phase/ 3-phase 200 VAC	100 W			
	200 W			
	400 W			
	750 W			
	1 kW			
	1.5 kW			
3-phase 200 VAC	2 kW	-		Included
	3 kW			
	5 kW			
	7.5 kW			

## ■ Understanding Servo Drive Model Numbers

The model number provides information such as the Servo Drive type, the applicable Servomotor capacity, and the power supply voltage.

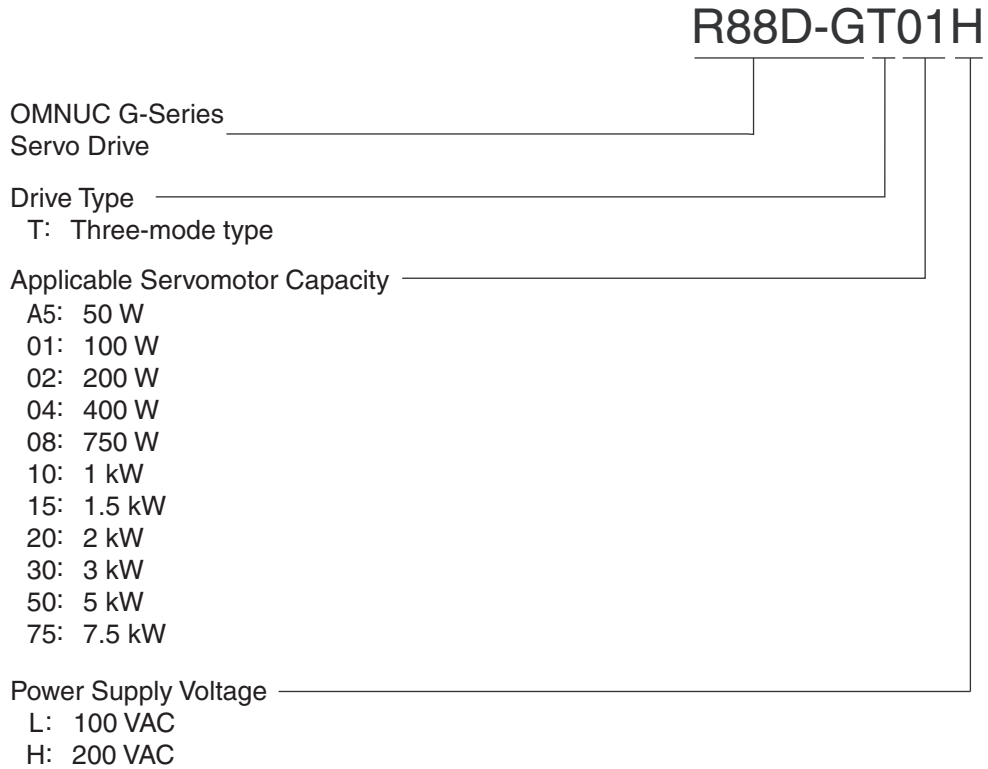

## Items to Check When Unpacking

### ■ Understanding Servomotor Model Numbers

R88M-GP10030H-BOS2

G-Series  
Servomotor

Motor Type  
Blank: Cylinder type  
P: Flat type

Servomotor Capacity

050: 50 W  
100: 100 W  
200: 200 W  
400: 400 W  
750: 750 W  
900: 900 W  
1K0: 1 kW  
1K5: 1.5 kW  
2K0: 2 kW  
3K0: 3 kW  
4K0: 4 kW  
4K5: 4.5 kW  
5K0: 5 kW  
6K0: 6 kW  
7K5: 7.5 kW

Rated Rotation Speed

10: 1,000 r/min  
15: 1,500 r/min  
20: 2,000 r/min  
30: 3,000 r/min

Applied Voltage

H: 200 VAC with incremental encoder specifications  
L: 100 VAC with incremental encoder specifications  
T: 200 VAC with absolute encoder specifications  
S: 100 VAC with absolute encoder specifications

Option

Blank: Straight shaft  
B: With brake  
O: With oil seal  
S2: With key and tap



■ Understanding Decelerator Model Numbers (Backlash = 3' Max.)

R88G-HPG14A05100PBJ

Decelerator for \_\_\_\_\_  
 G-Series Servomotors  
 Backlash = 3' Max.

Flange Size Number \_\_\_\_\_  
 11B :□40  
 14A :□60  
 20A :□90  
 32A :□120  
 50A :□170  
 65A :□230

Gear Ratio \_\_\_\_\_  
 05 :1/5  
 09 :1/9 (only frame number 11A)  
 11 :1/11 (except frame number 65A)  
 12 :1/12 (only frame number 65A)  
 20 :1/20 (only frame number 65A)  
 21 :1/21 (except frame number 65A)  
 25 :1/25 (only frame number 65A)  
 33 :1/33  
 45 :1/45

Applicable Servomotor Capacity \_\_\_\_\_  
 050 : 50 W  
 100 :100 W  
 200 :200 W  
 400 :400 W  
 750 :750 W  
 900 :900 W  
 1K0 :1 kW  
 1K5 :1.5 kW  
 2K0 :2 kW  
 3K0 :3 kW  
 4K0 :4 kW  
 4K5 :4.5 kW  
 5K0 :5 kW  
 6K0 :6 kW  
 7K5 :7.5 kW

Motor Type \_\_\_\_\_  
 Blank :3,000-r/min cylindrical Servomotors  
 P :flat Servomotors  
 S :2,000-r/min Servomotors  
 T :1,000-r/min Servomotors

Backlash \_\_\_\_\_  
 B :3' max.

Option \_\_\_\_\_  
 Blank :Straight shaft  
 J :With key and tap

## Items to Check When Unpacking

### ■ Understanding Decelerator Model Numbers (Backlash = 15' Max.)

R88G-VRSF09B100PCJ

Decelerator for \_\_\_\_\_  
G-Series Servomotors  
Backlash = 15' Max.

Gear Ratio \_\_\_\_\_

- 05 :1/5
- 09 :1/9
- 15 :1/15
- 25 :1/25

Flange Size Number \_\_\_\_\_

- B :□52
- C :□78
- D :□98

Applicable Servomotor Capacity \_\_\_\_\_

- 050 : 50 W
- 100 :100 W
- 200 :200 W
- 400 :400 W
- 750 :750 W

Motor Type \_\_\_\_\_

- Blank :3,000-r/min cylindrical Servomotors
- P :flat Servomotors

Backlash \_\_\_\_\_

- C :15' max.

Option \_\_\_\_\_

- J :With key

---



---

# About This Manual

---

This manual consists of the following chapters. Refer to this table and chose the required chapters of the manual.

		Overview
Chapter 1	Features and System Configuration	Describes the features and names of parts of the product as well as the EC Directives and the UL standards.
Chapter 2	Standard Models and Dimensions	Provides the model numbers, external and mounting hole dimensions for Servo Drives, Servomotors, Decelerators, and peripheral devices.
Chapter 3	Specifications	Provides the general specifications, characteristics, connector specifications, and I/O circuit specifications for Servo Drives, and the general specifications and characteristics for Servomotors, as well as specifications for accessories such as encoders.
Chapter 4	System Design	Describes the installation conditions for Servo Drives, Servomotors, and Decelerators, EMC conforming wiring methods, calculations of regenerative energy, and performance information on the External Regeneration Resistor.
Chapter 5	Operating Functions	Describes the control functions, parameter settings, and operation.
Chapter 6	Operation	Describes operating procedures and operating methods for each mode.
Chapter 7	Adjustment Functions	Describes gain adjustment functions, setting methods, and precautions.
Chapter 8	Troubleshooting	Describes items to check for troubleshooting, error diagnoses using alarm LED displays and the countermeasures, error diagnoses based on the operation status and the countermeasures, and periodic maintenance.
Chapter 9	Appendix	Provides examples of connections with OMRON PLCs and Position Controllers, and the parameter tables.

# Table of Contents

---

Introduction .....	1
Terms and Conditions Agreement .....	2
Precautions for Safe Use .....	4
Items to Check When Unpacking .....	10
About This Manual .....	15
<b>Chapter 1 Features and System Configuration</b>	
1-1 Overview.....	1-1
1-2 System Configuration .....	1-2
1-3 Names of Parts and Functions .....	1-3
1-4 System Block Diagrams .....	1-5
1-5 Applicable Standards.....	1-10
<b>Chapter 2 Standard Models and Dimensions</b>	
2-1 Standard Models .....	2-1
2-2 External and Mounting Hole Dimensions .....	2-25
<b>Chapter 3 Specifications</b>	
3-1 Servo Drive Specifications.....	3-1
3-2 Servomotor Specifications.....	3-32
3-3 Decelerator Specifications.....	3-47
3-4 Cable and Connector Specifications .....	3-57
3-5 Servo Relay Units and Cable Specifications .....	3-99
3-6 Parameter Unit Specifications .....	3-129
3-7 External Regeneration Resistor Specifications .....	3-130
3-8 Reactor Specifications.....	3-132
<b>Chapter 4 System Design</b>	
4-1 Installation Conditions .....	4-1
4-2 Wiring .....	4-11
4-3 Wiring Conforming to EMC Directives .....	4-27
4-4 Regenerative Energy Absorption.....	4-45

Chapter 5 Operating Functions

5-1	Position Control .....	5-1
5-2	Speed Control .....	5-3
5-3	Internally Set Speed Control .....	5-5
5-4	Torque Control .....	5-8
5-5	Switching the Control Mode .....	5-11
5-6	Forward and Reverse Drive Prohibit .....	5-14
5-7	Encoder Dividing .....	5-15
5-8	Electronic Gear .....	5-16
5-9	Overrun Limit.....	5-19
5-10	Brake Interlock .....	5-21
5-11	Gain Switching .....	5-25
5-12	Torque Limit .....	5-26
5-13	Soft Start .....	5-28
5-14	Position Command Filter .....	5-29
5-15	Speed Limit .....	5-30
5-16	User Parameters .....	5-31

Chapter 6 Operation

6-1	Operational Procedure .....	6-1
6-2	Preparing for Operation.....	6-2
6-3	Using the Parameter Unit.....	6-6
6-4	Setting the Mode .....	6-7
6-5	Trial Operation .....	6-28

Chapter 7 Adjustment Functions

7-1	Gain Adjustment.....	7-1
7-2	Realtime Autotuning.....	7-4
7-3	Normal Mode Autotuning .....	7-14
7-4	Disabling the Automatic Gain Adjustment Function .....	7-19
7-5	Manual Tuning .....	7-21

Chapter 8 Troubleshooting

8-1	Error Processing .....	8-1
8-2	Alarm Table .....	8-3
8-3	Troubleshooting .....	8-6
8-4	Overload Characteristics (Electronic Thermal Function).....	8-20
8-5	Periodic Maintenance.....	8-21

Chapter 9 Appendix

9-1	Connection Examples .....	9-1
9-2	Parameter Tables.....	9-11

Revision History.....	R-1
-----------------------	-----

## Table of Contents

---

# Chapter 1

## Features and System Configuration

1-1	Overview .....	1-1
	Overview of the G Series .....	1-1
	Features of the G Series .....	1-1
1-2	System Configuration .....	1-2
1-3	Names of Parts and Functions .....	1-3
	Servo Drive Part Names .....	1-3
	Servo Drive Functions .....	1-4
	Forward and Reverse Motor Rotation .....	1-4
1-4	System Block Diagrams .....	1-5
1-5	Applicable Standards .....	1-10
	EC Directives .....	1-10
	UL and CSA Standards .....	1-10
	Korean Radio Regulations (KC) .....	1-11
	SEMI F47 .....	1-11

---

---

# 1-1 Overview

---

## Overview of the G Series

The OMNUC G Series has been developed for a wide range of applications with position control, speed control, and torque control. The Series offers a wide variety of Servomotor capacities, ranging from 50 W to 7.5 kW. Servomotors with 2,500-pulse incremental encoders and high-resolution 17-bit absolute/incremental encoders are available as standard models.

The OMNUC G Series features realtime autotuning and adaptive filter functions that automatically perform complicated gain adjustments. A notch filter can also be automatically set to suppress machine vibration by reducing mechanical resonance during operation. The damping control function of the OMNUC G Series realizes stable stopping performance in a mechanism which vibrates because of the low rigidity of the load.

## Features of the G Series

The OMNUC G Series has the following features.

### ■ High-speed Response

The G-Series AC Servomotors and Servo Drives have achieved high-speed response capabilities exceeding OMRON's W-Series models, with a high-response frequency of 1 kHz (compared to 400 Hz for the W Series).

### ■ Suppressing Vibration of Low-rigidity Mechanisms during Acceleration/Deceleration

The damping control function suppresses vibration of low-rigidity mechanisms or devices whose ends tend to vibrate. Two vibration filters are provided to enable switching the vibration frequency automatically according to the direction of rotation and also via an external signal. In addition, the settings can be made easily merely by just setting the vibration frequency and filter values, and you are assured of stable operation even if the settings are inappropriate.

### ■ High-speed Positioning via Resonance Suppression Control

The realtime autotuning function automatically estimates the load inertia of the machine in realtime and sets the optimal gain. The adaptive filter automatically suppresses vibration caused by resonance. Also, two independent notch filters make it possible to reduce vibration of a mechanism with multiple resonance frequencies.

### ■ Command Control Mode Switching

Operation can be performed by switching between two of the following control modes: Position control, speed control (including internal speed) and torque control. Therefore, a variety of applications can be supported by one Servo Drive.

### ■ Simplified Speed Control with Internal Speed Settings

Eight internal speed settings allow you to change the speed easily by using external signals.



# 1-2 System Configuration

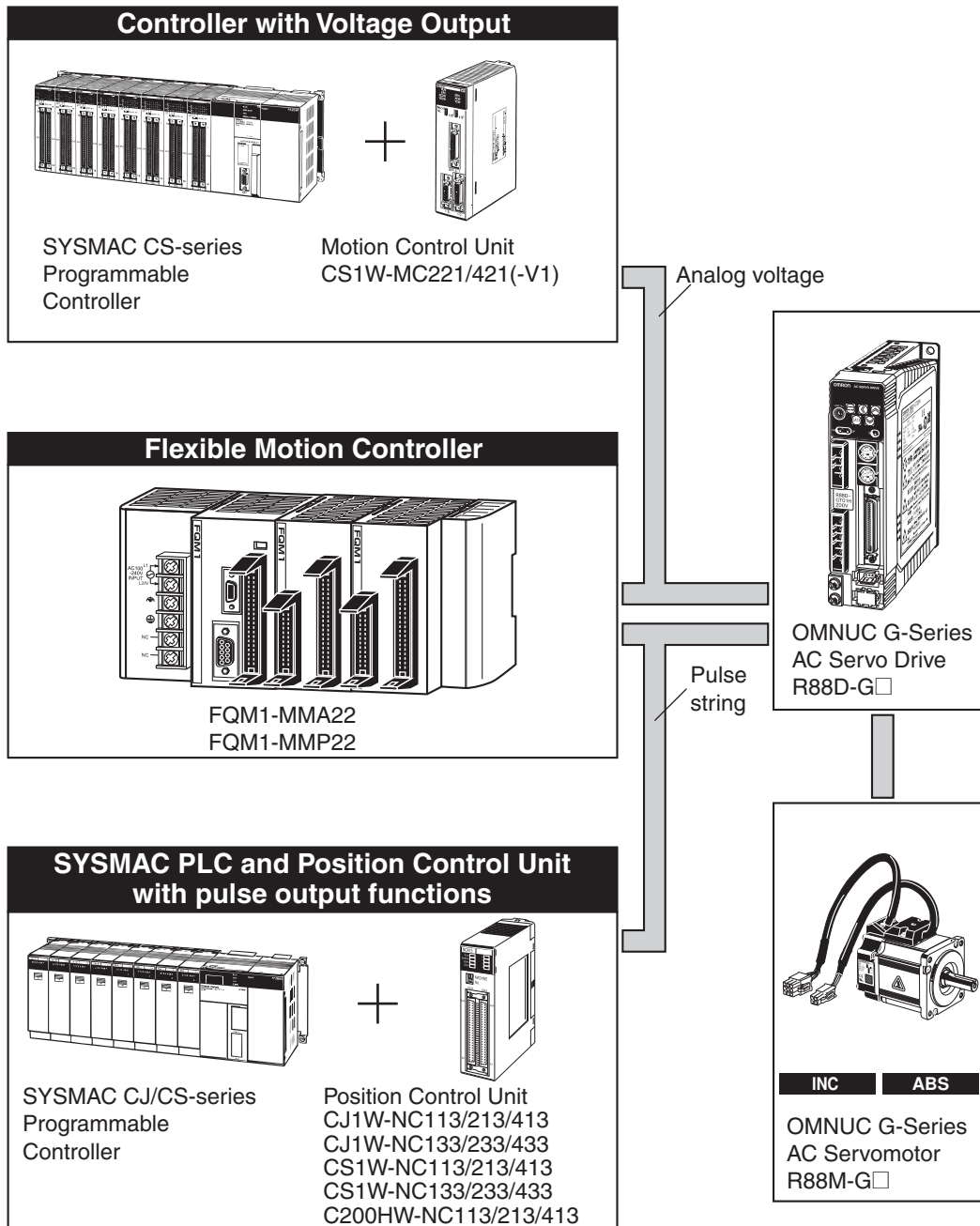

♦ Servomotors with absolute encoders can be used in combination with CS1W-MC221/421(-V1) Motion Control Units.

# 1-3 Names of Parts and Functions

## Servo Drive Part Names

Features and System Configuration

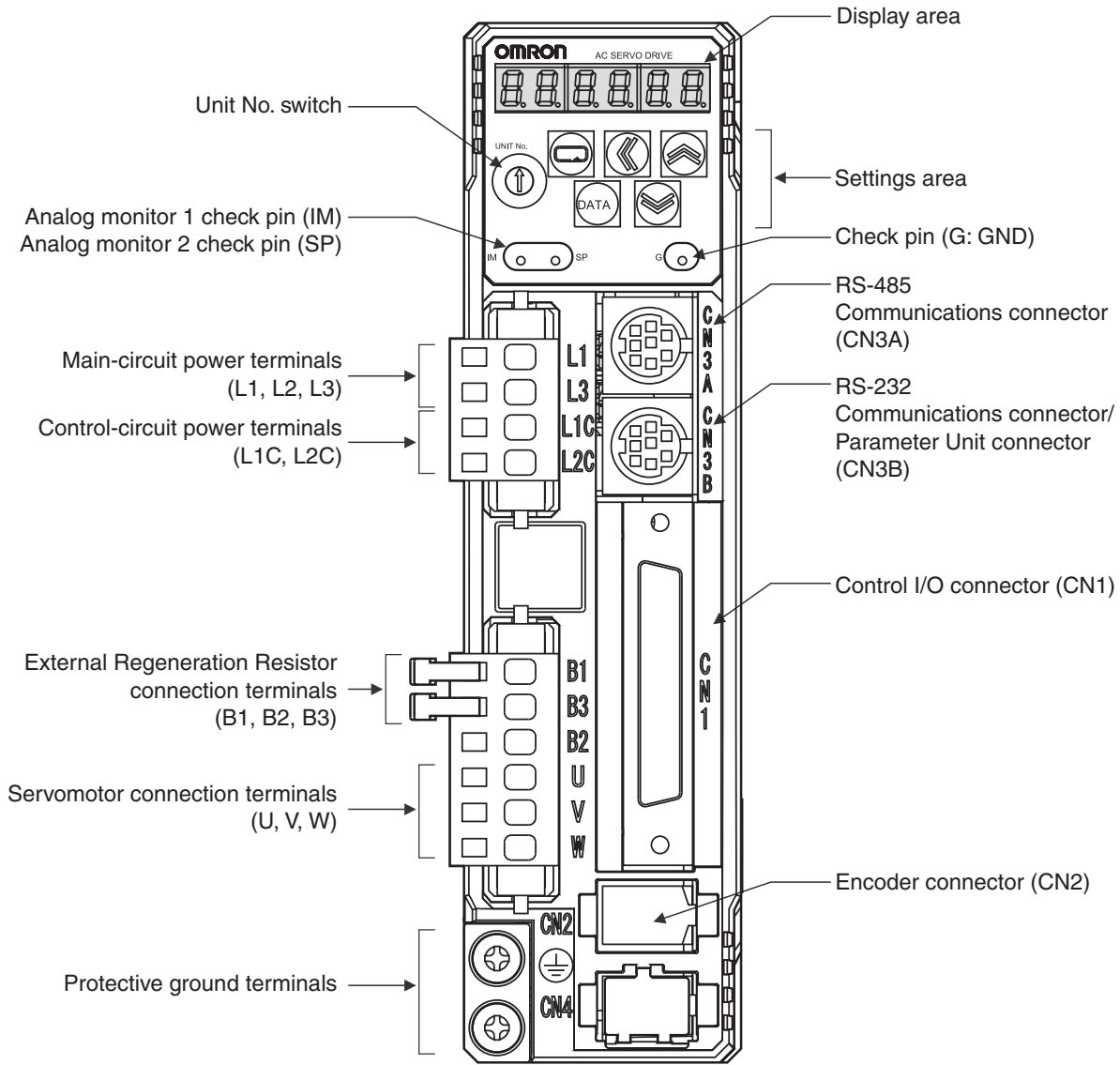

## Servo Drive Functions

### ■ Display Area

A 6-digit 7-segment LED display shows the Servo Drive status, alarm codes, parameters, and other information.

### ■ Check Pins (IM, SP, and G)

The actual Servomotor speed, command speed, torque, and number of accumulated pulses can be measured based on the analog voltage level by using an oscilloscope. The type of signal to output and the output voltage level are set in the SP Selection (Pn07) and IM Selection (Pn08) parameters. For details, refer to *5-16 User Parameters* on page 5-31.

### ■ Unit No. Switch

The Servo Drive number in serial communications is set to a value from 0 to F. This number is used to identify which Servo Drive the computer is accessing in RS-232/485 communications between multiple Servo Drives and a computer.

## Forward and Reverse Motor Rotation

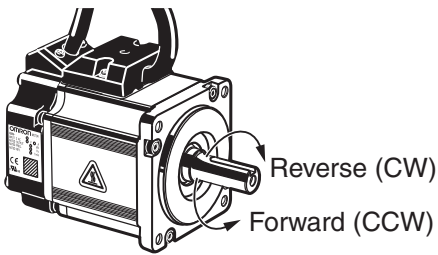

When the motor output shaft is viewed from the end, counterclockwise (CCW) rotation is forward and clockwise (CW) rotation is reverse.

# 1-4 System Block Diagrams

## R88D-GTA5L/-GT01L/-GT02L/-GTA5H/-GT01H/-GT02H/-GT04H

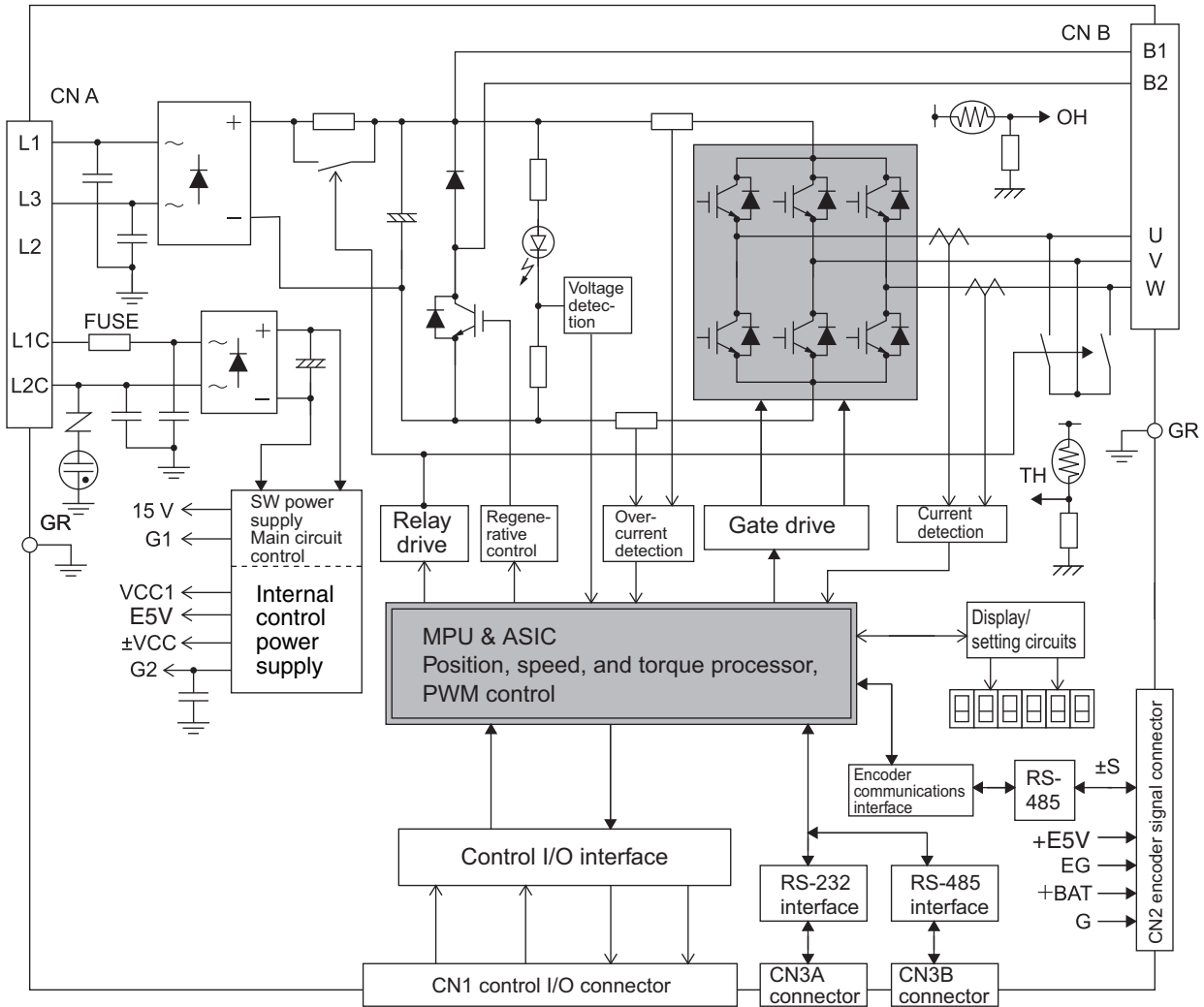

R88D-GT04L/-GT08H/-GT10H/-GT15H

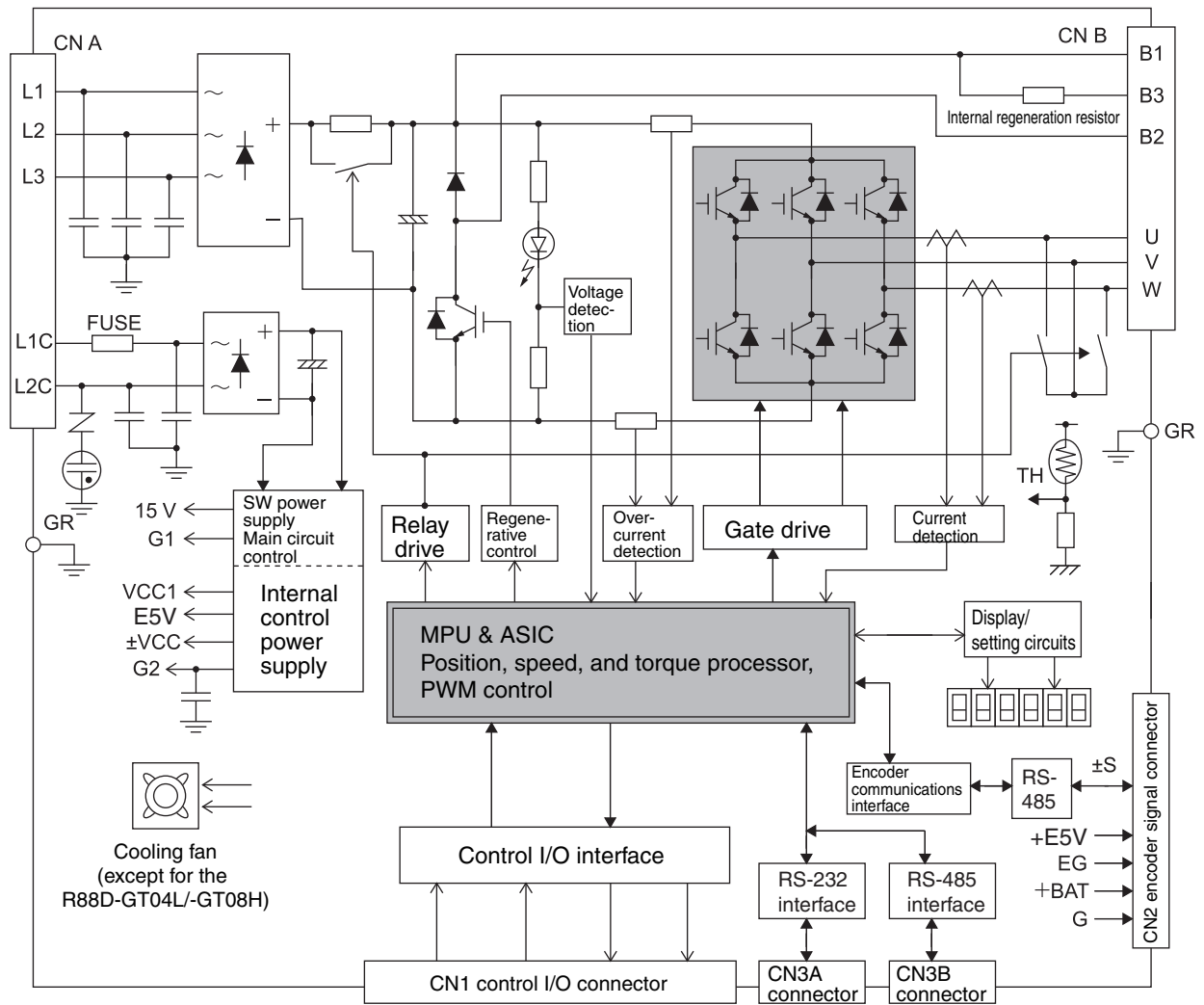

R88D-GT20H

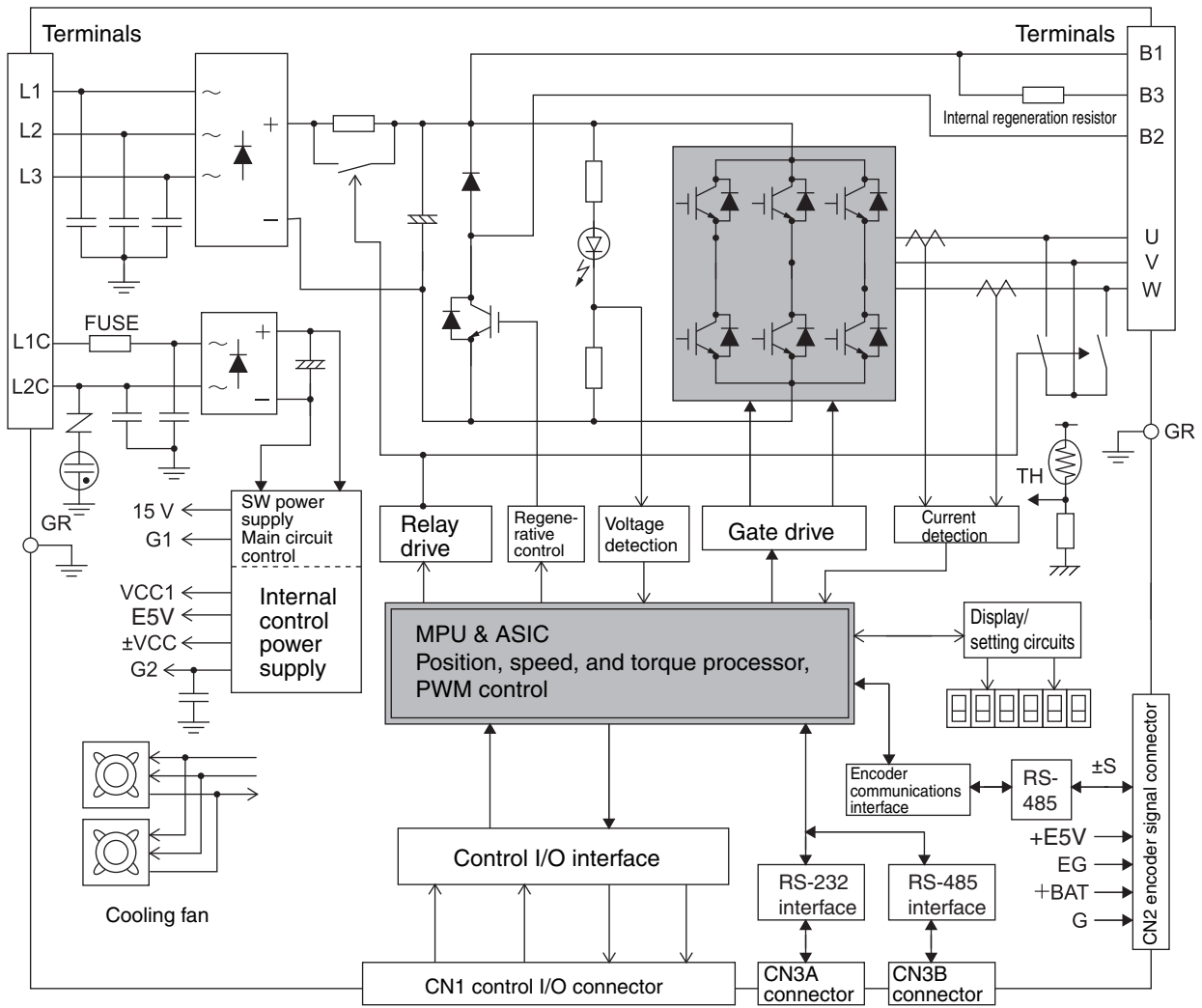

R88D-GT30H/GT50H

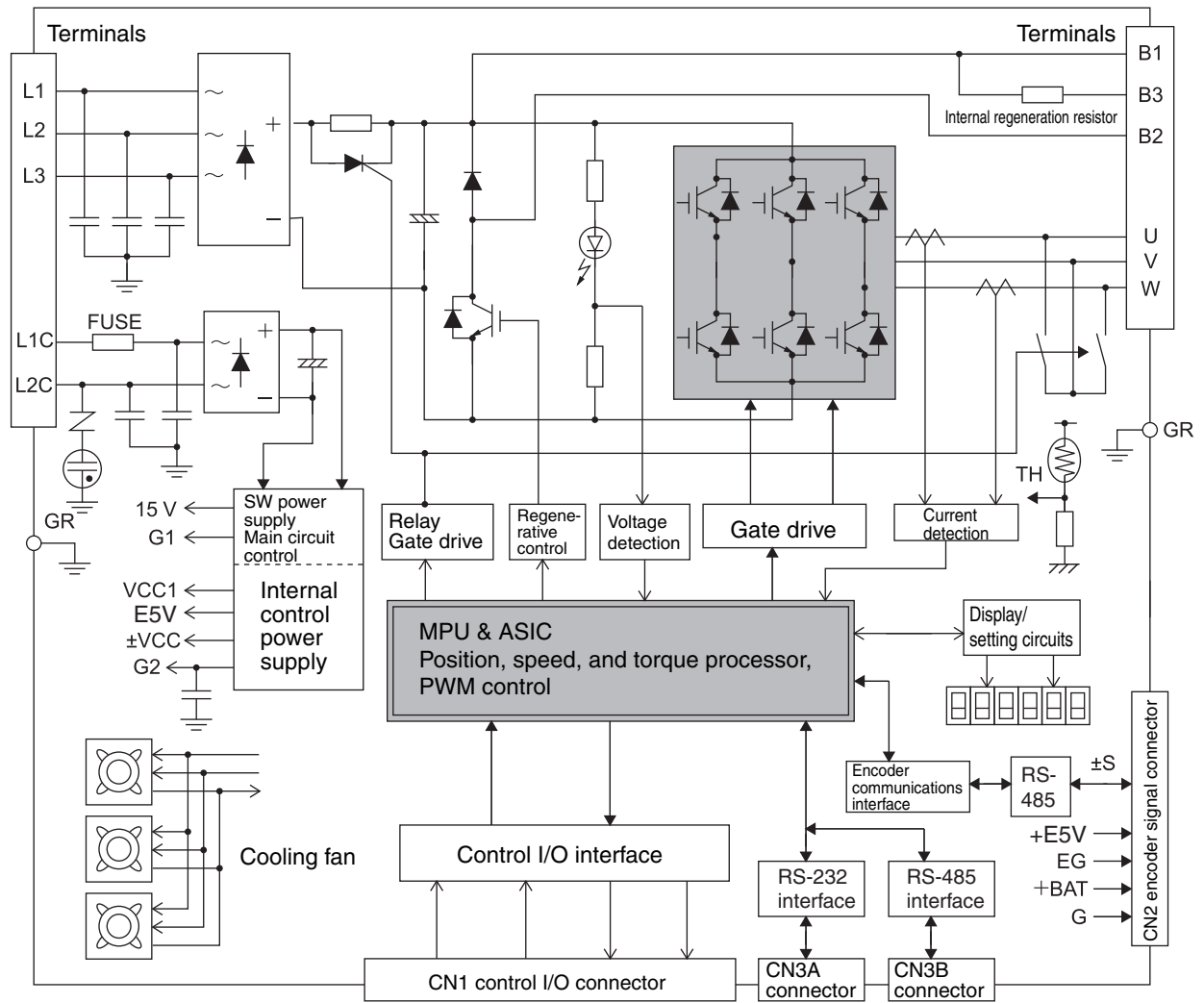

R88D-GT75H

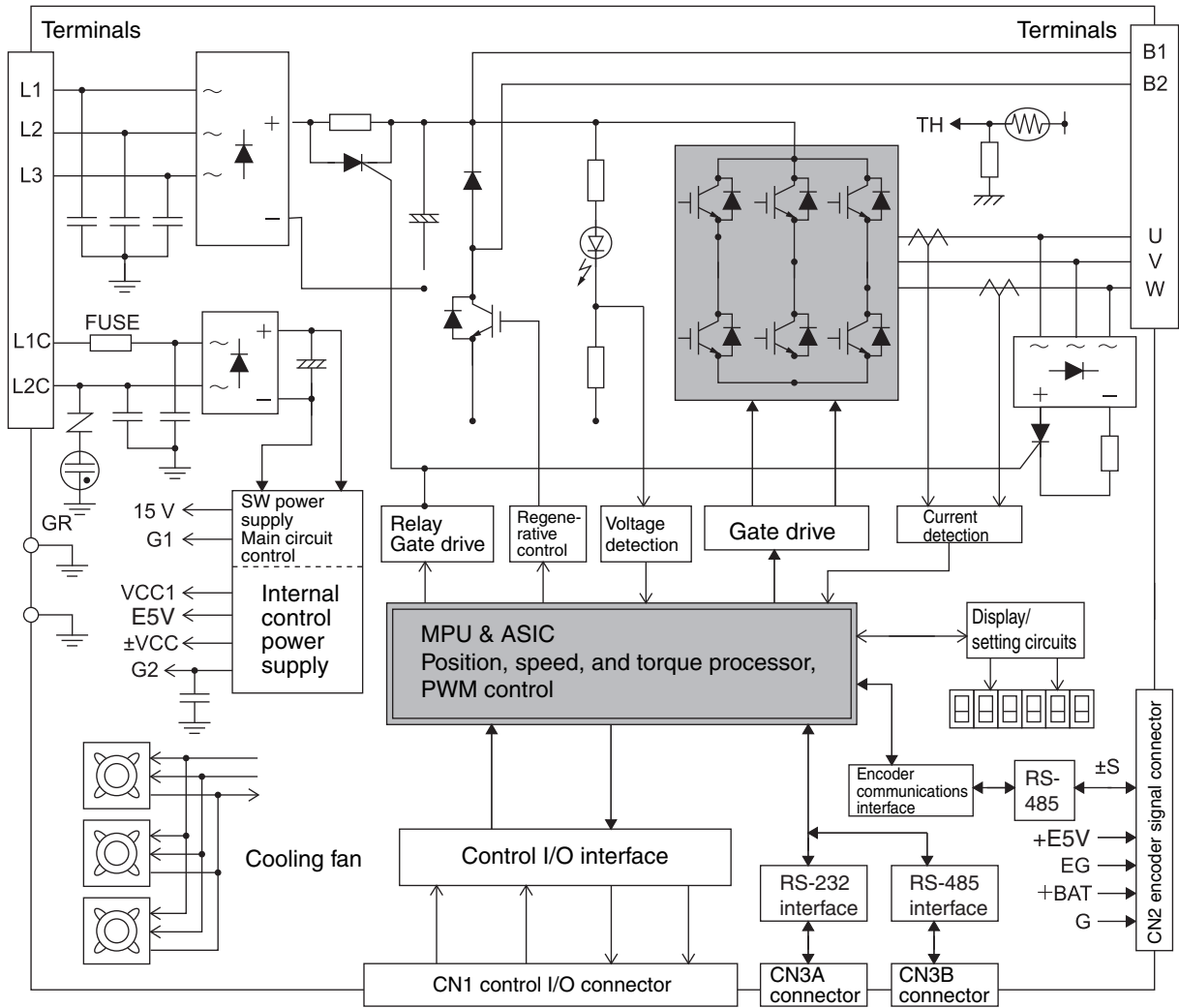



# 1-5 Applicable Standards

## EC Directives

EC Directive	Product	Applicable standards	Comments
Low Voltage Directive	AC Servo Drive	EN 50178	Safety requirements for electrical equipment for measurement, control, or laboratory use
	AC Servomotor	IEC 60034-1/-5	Rotating electrical machines
EMC Directive	AC Servo Drive	EN 55011 Class A Group1	Limits of radio disturbance and measurement methods for industrial, scientific, and medical radio-frequency equipment
		EN 61000-6-2	Electromagnetic compatibility (EMC) Immunity standard for industrial environments
		IEC 61000-4-2	Electrostatic discharge immunity testing
		IEC 61000-4-3	Radio frequency radiation field immunity testing
		IEC 61000-4-4	Electrical fast transient burst immunity testing
		IEC 61000-4-5	Lightning surge immunity testing
		IEC 61000-4-6	High-frequency conduction immunity testing
		IEC 61000-4-11	Momentary power interruption immunity testing

Note To conform to EMC Directives, the Servomotor and Servo Drive must be installed under the conditions described in *Wiring Conforming to EMC Directives* on page 4-27.

## UL and CSA Standards

Standard	Product	Applicable standards	File number	Comments
UL standard	AC Servo Drive	UL 508C	E179149	Power conversion equipment
	AC Servomotor *1	UL1004-1	E331224	Electric motor
CSA standard	AC Servomotors*1	CSA22.2 No.100	E179189	Motor and generator

\*1 The approval of UL and cUL is pending for motor capacities of 6 to 7.5 kW.

## 1-5 Applicable Standards

The Servo Drives and Servomotors comply with UL 508C (file No. E179149) as long as the following installation conditions 1 and 2 are met.

- (1) Use the Servo Drive in a pollution degree 1 or 2 environment as defined in IEC 60664-1 (example: installation in an IP54 control panel).
- (2) Be sure to connect a circuit breaker or fuse, which is a UL-listed product with LISTED and  mark, between the power supply and noise filter.

Refer to the following table for the rated current of the circuit breaker or fuse.  
Use copper wiring with a temperature rating of 60°C or higher.

Drive model	Circuit breaker (rated current) (A)
R88D-GTA5L	10
R88D-GT01L	10
R88D-GT02L	10
R88D-GT04L	10
R88D-GT01H	10
R88D-GT02H	10
R88D-GT04H	10
R88D-GT08H	15
R88D-GT10H	15
R88D-GT15H	20
R88D-GT20H	30
R88D-GT30H	50
R88D-GT50H	50
R88D-GT75H	60

## Korean Radio Regulations (KC)

- ♦ The G-series Servo Drives comply with the Korean Radio Regulations (KC).
- ♦ The G-series Servomotors do not comply with the Korean Radio Regulations (KC).

## SEMI F47

- ♦ Some Servo Drives conform to the SEMI F47 standard for momentary power interruptions (voltage sag immunity) for no-load or light-load operation.
- ♦ This standard applies to semiconductor manufacturing equipment.

**Note 1.** It does not apply to Servo Drivers with single-phase 100-V specifications or with 24-VDC specifications for the control power input.

**Note 2.** Always perform evaluation testing for SEMI F47 compliance in the actual system.

# Chapter 2

## Standard Models and Dimensions

2-1	Standard Models .....	2-1
	Servo Drives .....	2-1
	Servomotors.....	2-2
	Servo Drive-Servomotor Combinations .....	2-5
	Decelerators.....	2-7
	Accessories and Cables .....	2-14
2-2	External and Mounting Hole Dimensions .....	2-25
	Servo Drives .....	2-25
	Servomotors.....	2-35
	Parameter Unit Dimensions .....	2-45
	Servomotor and Decelerator Combinations .....	2-46
	Decelerator Dimensions.....	2-49
	External Regeneration Resistor Dimensions .....	2-63
	Reactor Dimensions.....	2-64

# 2-1 Standard Models

2

## Servo Drives

Standard Models and Dimensions

Specifications		Model
Single-phase 100 VAC	50 W	R88D-GTA5L
	100 W	R88D-GT01L
	200 W	R88D-GT02L
	400 W	R88D-GT04L
Single-phase 200 VAC	50 W	R88D-GT01H
	100 W	
	200 W	R88D-GT02H
	400 W	R88D-GT04H
Single-phase/three-phase 200 VAC	750 W	R88D-GT08H
	1 kW	R88D-GT10H
	900 W	R88D-GT15H
	1 kW	
	1.5 kW	
Three-phase 200 VAC	2 kW	R88D-GT20H
	2 kW	R88D-GT30H
	3 kW	
	3 kW	R88D-GT50H
	4 kW	
	4.5 kW	
	5 kW	R88D-GT75H
	6 kW	
7.5 kW		

## Servomotors

### ■ 3,000-r/min Servomotors

Specifications		Model					
		With incremental encoder		With absolute encoder			
		Straight shaft without key	Straight shaft with key and tap	Straight shaft without key	Straight shaft with key and tap		
With-out brake	100 V	50 W	R88M-G05030H	R88M-G05030H-S2	R88M-G05030T	R88M-G05030T-S2	
		100 W	R88M-G10030L	R88M-G10030L-S2	R88M-G10030S	R88M-G10030S-S2	
		200 W	R88M-G20030L	R88M-G20030L-S2	R88M-G20030S	R88M-G20030S-S2	
		400 W	R88M-G40030L	R88M-G40030L-S2	R88M-G40030S	R88M-G40030S-S2	
	200 V	50 W	R88M-G05030H	R88M-G05300H-S2	R88M-G05030T	R88M-G05030T-S2	
		100 W	R88M-G10030H	R88M-G10030H-S2	R88M-G10030T	R88M-G10030T-S2	
		200 W	R88M-G20030H	R88M-G20030H-S2	R88M-G20030T	R88M-G20030T-S2	
		400 W	R88M-G40030H	R88M-G40030H-S2	R88M-G40030T	R88M-G40030T-S2	
		750 W	R88M-G75030H	R88M-G75030H-S2	R88M-G75030T	R88M-G75030T-S2	
		1 kW	---	---	R88M-G1K030T	R88M-G1K030T-S2	
		1.5 kW	---	---	R88M-G1K530T	R88M-G1K530T-S2	
		2 kW	---	---	R88M-G2K030T	R88M-G2K030T-S2	
		3 kW	---	---	R88M-G3K030T	R88M-G3K030T-S2	
		4 kW	---	---	R88M-G4K030T	R88M-G4K030T-S2	
		5 kW	---	---	R88M-G5K030T	R88M-G5K030T-S2	
	With brake	100 V	50 W	R88M-G05030H-B	R88M-G05030H-BS2	R88M-G05030T-B	R88M-G05030T-BS2
			100 W	R88M-G10030L-B	R88M-G10030L-BS2	R88M-G10030S-B	R88M-G10030S-BS2
			200 W	R88M-G20030L-B	R88M-G20030L-BS2	R88M-G20030S-B	R88M-G20030S-BS2
			400 W	R88M-G40030L-B	R88M-G40030L-BS2	R88M-G40030S-B	R88M-G40030S-BS2
200 V		50 W	R88M-G05030H-B	R88M-G05030H-BS2	R88M-G05030T-B	R88M-G05030T-BS2	
		100 W	R88M-G10030H-B	R88M-G10030H-BS2	R88M-G10030T-B	R88M-G10030T-BS2	
		200 W	R88M-G20030H-B	R88M-G20030H-BS2	R88M-G20030T-B	R88M-G20030T-BS2	
		400 W	R88M-G40030H-B	R88M-G40030H-BS2	R88M-G40030T-B	R88M-G40030T-BS2	
		750 W	R88M-G75030H-B	R88M-G75030H-BS2	R88M-G75030T-B	R88M-G75030T-BS2	
		1 kW	---	---	R88M-G1K030T-B	R88M-G1K030T-BS2	
		1.5 kW	---	---	R88M-G1K530T-B	R88M-G1K530T-BS2	
		2 kW	---	---	R88M-G2K030T-B	R88M-G2K030T-BS2	
		3 kW	---	---	R88M-G3K030T-B	R88M-G3K030T-BS2	
		4 kW	---	---	R88M-G4K030T-B	R88M-G4K030T-BS2	
		5 kW	---	---	R88M-G5K030T-B	R88M-G5K030T-BS2	

**Note** Models with oil seals are also available.

## 2-1 Standard Models

### ■ 3,000-r/min Flat Servomotors

Specifications			Model			
			With incremental encoder		With absolute encoder	
			Straight shaft without key	Straight shaft with key and tap	Straight shaft without key	Straight shaft with key and tap
Without brake	100 V	100 W	R88M-GP10030L	R88M-GP10030L-S2	R88M-GP10030S	R88M-GP10030S-S2
		200 W	R88M-GP20030L	R88M-GP20030L-S2	R88M-GP20030S	R88M-GP20030S-S2
		400 W	R88M-GP40030L	R88M-GP40030L-S2	R88M-GP40030S	R88M-GP40030S-S2
	200 V	100 W	R88M-GP10030H	R88M-GP10030H-S2	R88M-GP10030T	R88M-GP10030T-S2
		200 W	R88M-GP20030H	R88M-GP20030H-S2	R88M-GP20030T	R88M-GP20030T-S2
		400 W	R88M-GP40030H	R88M-GP40030H-S2	R88M-GP40030T	R88M-GP40030T-S2
With brake	100 V	100 W	R88M-GP10030L-B	R88M-GP10030L-BS2	R88M-GP10030S-B	R88M-GP10030S-BS2
		200 W	R88M-GP20030L-B	R88M-GP20030L-BS2	R88M-GP20030S-B	R88M-GP20030S-BS2
		400 W	R88M-GP40030L-B	R88M-GP40030L-BS2	R88M-GP40030S-B	R88M-GP40030S-BS2
	200 V	100 W	R88M-GP10030H-B	R88M-GP10030H-BS2	R88M-GP10030T-B	R88M-GP10030T-BS2
		200 W	R88M-GP20030H-B	R88M-GP20030H-BS2	R88M-GP20030T-B	R88M-GP20030T-BS2
		400 W	R88M-GP40030H-B	R88M-GP40030H-BS2	R88M-GP40030T-B	R88M-GP40030T-BS2

**Note** Models with oil seals are also available.

### ■ 2,000-r/min Servomotors

Specifications			Model	
			With absolute encoder	
			Straight shaft without key	Straight shaft with key and tap
Without brake	200 V	1 kW	R88M-G1K020T	R88M-G1K020T-S2
		1.5 kW	R88M-G1K520T	R88M-G1K520T-S2
		2 kW	R88M-G2K020T	R88M-G2K020T-S2
		3 kW	R88M-G3K020T	R88M-G3K020T-S2
		4 kW	R88M-G4K020T	R88M-G4K020T-S2
		5 kW	R88M-G5K020T	R88M-G5K020T-S2
		7.5 kW	R88M-G7K515T	R88M-G7K515T-S2
With brake	200 V	1 kW	R88M-G1K020T-B	R88M-G1K020T-BS2
		1.5 kW	R88M-G1K520T-B	R88M-G1K520T-BS2
		2 kW	R88M-G2K020T-B	R88M-G2K020T-BS2
		3 kW	R88M-G3K020T-B	R88M-G3K020T-BS2
		4 kW	R88M-G4K020T-B	R88M-G4K020T-BS2
		5 kW	R88M-G5K020T-B	R88M-G5K020T-BS2
		7.5 kW	R88M-G7K515T-B	R88M-G7K515T-BS2

**Note 1.** Models with oil seals are also available.

**Note 2.** The rated rotation speed for 7.5-kW Servomotors is 1,500 r/min.

■ 1,000-r/min Servomotors

Specifications		Model		
		With absolute encoder		
		Straight shaft without key	Straight shaft with key and tap	
Without brake	200 V	900 W	R88M-G90010T	R88M-G90010T-S2
		2 kW	R88M-G2K010T	R88M-G2K010T-S2
		3 kW	R88M-G3K010T	R88M-G3K010T-S2
		4.5 kW	R88M-G4K510T	R88M-G4K510T-S2
		6 kW	R88M-G6K010T	R88M-G6K010T-S2
With brake	200 V	900 W	R88M-G90010T-B	R88M-G90010T-BS2
		2 kW	R88M-G2K010T-B	R88M-G2K010T-BS2
		3 kW	R88M-G3K010T-B	R88M-G3K010T-BS2
		4.5 kW	R88M-G4K510T-B	R88M-G4K510T-BS2
		6 kW	R88M-G6K010T-B	R88M-G6K010T-BS2

**Note** Models with oil seals are also available.

## Servo Drive-Servomotor Combinations

The tables in this section show the possible combinations of OMNUC G-Series Servo Drives and Servomotors. The Servomotors and Servo Drives can only be used in the listed combinations. The box (-□) at the end of the model number is for options, such as the shaft type, brake and Decelerators.

### ■ 3,000-r/min Servomotors and Servo Drives

Voltage	Servomotor			Servo Drive
	Rated output	With incremental encoder	With absolute encoder	
100 V	50 W	R88M-G05030H-□	R88M-G05030T-□	R88D-GTA5L
	100 W	R88M-G10030L-□	R88M-G10030S-□	R88D-GT01L
	200 W	R88M-G20030L-□	R88M-G20030S-□	R88D-GT02L
	400 W	R88M-G40030L-□	R88M-G40030S-□	R88D-GT04L
Single-phase 200 V	50 W	R88M-G05030H-□	R88M-G05030T-□	R88D-GT01H
	100 W	R88M-G10030H-□	R88M-G10030T-□	R88D-GT01H
	200 W	R88M-G20030H-□	R88M-G20030T-□	R88D-GT02H
	400 W	R88M-G40030H-□	R88M-G40030T-□	R88D-GT04H
Single-phase/three-phase 200 V	750 W	R88M-G75030H-□	R88M-G75030T-□	R88D-GT08H
	1 kW	---	R88M-G1K030T-□	R88D-GT15H
	1.5 kW	---	R88M-G1K530T-□	R88D-GT15H
Three-phase 200 V	2 kW	---	R88M-G2K030T-□	R88D-GT20H
	3 kW	---	R88M-G3K030T-□	R88D-GT30H
	4 kW	---	R88M-G4K030T-□	R88D-GT50H
	5 kW	---	R88M-G5K030T-□	R88D-GT50H

### ■ 3,000-r/min Flat Servomotors and Servo Drives

Voltage	Servomotor			Servo Drive
	Rated output	With incremental encoder	With absolute encoder	
100 V	100 W	R88M-GP10030L-□	R88M-GP10030S-□	R88D-GT01L
	200 W	R88M-GP20030L-□	R88M-GP20030S-□	R88D-GT02L
	400 W	R88M-GP40030L-□	R88M-GP40030S-□	R88D-GT04L
Single-phase 200 V	100 W	R88M-GP10030H-□	R88M-GP10030T-□	R88D-GT01H
	200 W	R88M-GP20030H-□	R88M-GP20030T-□	R88D-GT02H
	400 W	R88M-GP40030H-□	R88M-GP40030T-□	R88D-GT04H



### ■ 2,000-r/min Servomotors and Servo Drives

Voltage	Servomotor		Servo Drive
	Rated output	With absolute encoder	
Single-phase/ three-phase 200 V	1 kW	R88M-G1K020T-□	R88D-GT10H
	1.5 kW	R88M-G1K520T-□	R88D-GT15H
Three-phase 200 V	2 kW	R88M-G2K020T-□	R88D-GT20H
	3 kW	R88M-G3K020T-□	R88D-GT30H
	4 kW	R88M-G4K020T-□	R88D-GT50H
	5 kW	R88M-G5K020T-□	R88D-GT50H
	7.5 kW	R88M-G7K515T-□	R88D-GT75H

### ■ 1,000-r/min Servomotors and Servo Drives

Voltage	Servomotor		Servo Drive
	Rated output	With absolute encoder	
Single-phase/ three-phase 200 V	900 W	R88M-G90010T-□	R88D-GT15H
Three-phase 200 V	2 kW	R88M-G2K010T-□	R88D-GT30H
	3 kW	R88M-G3K010T-□	R88D-GT50H
	4.5 kW	R88M-G4K510T-□	R88D-GT50H
	6 kW	R88M-G6K010T-□	R88D-GT75H

## 2-1 Standard Models

### Decelerators

The following types of Decelerators are available for OMNUC G-Series Servomotors. Select a Decelerator based on the Servomotor capacity.

■ Backlash = 3' Max.

#### Decelerators for 3,000-r/min Servomotors

Specifications		Model
Motor capacity	Gear ratio	
50 W	1/5	R88G-HPG11B05100B□
	1/9	R88G-HPG11B09050B□
	1/21	R88G-HPG14A21100B□
	1/33	R88G-HPG14A33050B□
	1/45	R88G-HPG14A45050B□
100 W	1/5	R88G-HPG11B05100B□
	1/11	R88G-HPG14A11100B□
	1/21	R88G-HPG14A21100B□
	1/33	R88G-HPG20A33100B□
	1/45	R88G-HPG20A45100B□
200 W	1/5	R88G-HPG14A05200B□
	1/11	R88G-HPG14A11200B□
	1/21	R88G-HPG20A21200B□
	1/33	R88G-HPG20A33200B□
	1/45	R88G-HPG20A45200B□
400 W	1/5	R88G-HPG14A05400B□
	1/11	R88G-HPG20A11400B□
	1/21	R88G-HPG20A21400B□
	1/33	R88G-HPG32A33400B□
	1/45	R88G-HPG32A45400B□
750 W	1/5	R88G-HPG20A05750B□
	1/11	R88G-HPG20A11750B□
	1/21	R88G-HPG32A21750B□
	1/33	R88G-HPG32A33750B□
	1/45	R88G-HPG32A45750B□

Specifications		Model
Motor capacity	Gear ratio	
1 kW	1/5	R88G-HPG32A051K0B□
	1/11	R88G-HPG32A111K0B□
	1/21	R88G-HPG32A211K0B□
	1/33	R88G-HPG32A331K0B□
	1/45	R88G-HPG50A451K0B□
1.5 kW	1/5	R88G-HPG32A052K0B□
	1/11	R88G-HPG32A112K0B□
	1/21	R88G-HPG32A211K5B□
	1/33	R88G-HPG50A332K0B□
	1/45	R88G-HPG50A451K5B□
2 kW	1/5	R88G-HPG32A052K0B□
	1/11	R88G-HPG32A112K0B□
	1/21	R88G-HPG50A212K0B□
	1/33	R88G-HPG50A332K0B□
3 kW	1/5	R88G-HPG32A053K0B□
	1/11	R88G-HPG50A113K0B□
	1/21	R88G-HPG50A213K0B□
4 kW	1/5	R88G-HPG32A054K0B□
	1/11	R88G-HPG50A115K0B□
5 kW	1/5	R88G-HPG50A055K0B□
	1/11	R88G-HPG50A115K0B□

**Note 1.** The standard models have a straight shaft.

**Note 2.** Models with a key and tap are indicated with “J” at the end of the model number (the suffix shown in the box). (Example: R88G-HPG11B05100BJ)

## 2-1 Standard Models

### Decelerators for 2,000-r/min Servomotors

Specifications		Model
Motor capacity	Gear ratio	
1 kW	1/5	R88G-HPG32A053K0B□
	1/11	R88G-HPG32A112K0SB□
	1/21	R88G-HPG32A211K0SB□
	1/33	R88G-HPG50A332K0SB□
	1/45	R88G-HPG50A451K0SB□
1.5 kW	1/5	R88G-HPG32A053K0B□
	1/11	R88G-HPG32A112K0SB□
	1/21	R88G-HPG50A213K0B□
	1/33	R88G-HPG50A332K0SB□
2 kW	1/5	R88G-HPG32A053K0B□
	1/11	R88G-HPG32A112K0SB□
	1/21	R88G-HPG50A213K0B□
	1/33	R88G-HPG50A332K0SB□
3 kW	1/5	R88G-HPG32A054K0B□
	1/11	R88G-HPG50A115K0B□
	1/21	R88G-HPG50A213K0SB□
	1/25	R88G-HPG65A253K0SB□
4 kW	1/5	R88G-HPG50A054K0SB□
	1/11	R88G-HPG50A114K0SB□
	1/20	R88G-HPG65A204K0SB□
	1/25	R88G-HPG65A254K0SB□
5 kW	1/5	R88G-HPG50A055K0SB□
	1/11	R88G-HPG50A115K0SB□
	1/20	R88G-HPG65A205K0SB□
	1/25	R88G-HPG65A255K0SB□
7.5 kW	1/5	R88G-HPG65A057K5SB□
	1/12	R88G-HPG65A127K5SB□

**Note 1.** The standard models have a straight shaft.

**Note 2.** Models with a key and tap are indicated with “J” at the end of the model number (the suffix shown in the box). (Example: R88G-HPG32A053K0BJ)

## Decelerators for 1,000-r/min Servomotors

Specifications		Model
Motor capacity	Gear ratio	
900 W	1/5	R88G-HPG32A05900TB□
	1/11	R88G-HPG32A11900TB□
	1/21	R88G-HPG50A21900TB□
	1/33	R88G-HPG50A33900TB□
2 kW	1/5	R88G-HPG32A052K0TB□
	1/11	R88G-HPG50A112K0TB□
	1/21	R88G-HPG50A212K0TB□
	1/25	R88G-HPG65A255K0SB□
3 kW	1/5	R88G-HPG50A055K0SB□
	1/11	R88G-HPG50A115K0SB□
	1/20	R88G-HPG65A205K0SB□
	1/25	R88G-HPG65A255K0SB□
4.5 kW	1/5	R88G-HPG50A054K5TB□
	1/12	R88G-HPG65A127K5SB□
	1/20	R88G-HPG65A204K5TB□
6 kW	1/5	R88G-HPG65A057K5SB□
	1/12	R88G-HPG65A127K5SB□

**Note 1.** The standard models have a straight shaft.

**Note 2.** Models with a key and tap are indicated with “J” at the end of the model number (the suffix shown in the box). (Example: R88G-HPG32A05900TBJ)

Decelerators for 3,000-r/min Flat Servomotors

Specifications		Model
Motor capacity	Gear ratio	
100 W	1/5	R88G-HPG11B05100PB□
	1/11	R88G-HPG14A11100PB□
	1/21	R88G-HPG14A21100PB□
	1/33	R88G-HPG20A33100PB□
	1/45	R88G-HPG20A45100PB□
200 W	1/5	R88G-HPG14A05200PB□
	1/11	R88G-HPG20A11200PB□
	1/21	R88G-HPG20A21200PB□
	1/33	R88G-HPG20A33200PB□
	1/45	R88G-HPG20A45200PB□
400 W	1/5	R88G-HPG20A05400PB□
	1/11	R88G-HPG20A11400PB□
	1/21	R88G-HPG20A21400PB□
	1/33	R88G-HPG32A33400PB□
	1/45	R88G-HPG32A45400PB□

**Note 1.** The standard models have a straight shaft.

**Note 2.** Models with a key and tap are indicated with “J” at the end of the model number (the suffix shown in the box). (Example: R88G-HPG11B05100PBJ)

■ Backlash = 15' Max.

**Decelerators for 3,000-r/min Servomotors (Straight Shaft with Key)**

Specifications		Model
Motor capacity	Gear ratio	
50 W	1/5	R88G-VRSF05B100CJ
	1/9	R88G-VRSF09B100CJ
	1/15	R88G-VRSF15B100CJ
	1/25	R88G-VRSF25B100CJ
100 W	1/5	R88G-VRSF05B100CJ
	1/9	R88G-VRSF09B100CJ
	1/15	R88G-VRSF15B100CJ
	1/25	R88G-VRSF25B100CJ
200 W	1/5	R88G-VRSF05B200CJ
	1/9	R88G-VRSF09C200CJ
	1/15	R88G-VRSF15C200CJ
	1/25	R88G-VRSF25C200CJ
400 W	1/5	R88G-VRSF05C400CJ
	1/9	R88G-VRSF09C400CJ
	1/15	R88G-VRSF15C400CJ
	1/25	R88G-VRSF25C400CJ
750 W	1/5	R88G-VRSF05C750CJ
	1/9	R88G-VRSF09D750CJ
	1/15	R88G-VRSF15D750CJ
	1/25	R88G-VRSF25D750CJ

## 2-1 Standard Models

### Decelerators for 3,000-r/min Flat Servomotors (Straight Shaft with Key)

Specifications		Model
Motor capacity	Gear ratio	
100 W	1/5	R88G-VRSF05B100PCJ
	1/9	R88G-VRSF09B100PCJ
	1/15	R88G-VRSF15B100PCJ
	1/25	R88G-VRSF25B100PCJ
200 W	1/5	R88G-VRSF05B200PCJ
	1/9	R88G-VRSF09C200PCJ
	1/15	R88G-VRSF15C200PCJ
	1/25	R88G-VRSF25C200PCJ
400 W	1/5	R88G-VRSF05C400PCJ
	1/9	R88G-VRSF09C400PCJ
	1/15	R88G-VRSF15C400PCJ
	1/25	R88G-VRSF25C400PCJ



## Accessories and Cables

### ■ Encoder Cables (Standard Cables)

Specifications	Model	
3,000-r/min Servomotors of 50 to 750 W with an absolute encoder, 3,000-r/min Flat Servomotors of 100 to 400 W with an absolute encoder	3 m	R88A-CRGA003C
	5 m	R88A-CRGA005C
	10 m	R88A-CRGA010C
	15 m	R88A-CRGA015C
	20 m	R88A-CRGA020C
	30 m	R88A-CRGA030C
	40 m	R88A-CRGA040C
	50 m	R88A-CRGA050C
3,000-r/min Servomotors of 50 to 750 W with an incremental encoder, 3,000-r/min Flat Servomotors of 100 to 400 W with an incremental encoder	3 m	R88A-CRGB003C
	5 m	R88A-CRGB005C
	10 m	R88A-CRGB010C
	15 m	R88A-CRGB015C
	20 m	R88A-CRGB020C
	30 m	R88A-CRGB030C
	40 m	R88A-CRGB040C
	50 m	R88A-CRGB050C
3,000-r/min Servomotors of 1 to 5 kW, 2,000-r/min Servomotors of 1 to 5 kW, 1,500-r/min Servomotors of 7.5 kW, 1,000-r/min Servomotors of 900 W to 6 kW	3 m	R88A-CRGC003N
	5 m	R88A-CRGC005N
	10 m	R88A-CRGC010N
	15 m	R88A-CRGC015N
	20 m	R88A-CRGC020N
	30 m	R88A-CRGC030N
	40 m	R88A-CRGC040N
	50 m	R88A-CRGC050N

## 2-1 Standard Models

### ■ Servomotor Power Cables (Standard Cables)

Specifications		Model	
		For Servomotor without brake	For Servomotor with brake
3,000-r/min Servomotors of 50 to 750 W, 3,000-r/min Flat Servomotors of 100 to 400 W	3 m	R88A-CAGA003S	---
	5 m	R88A-CAGA005S	---
	10 m	R88A-CAGA010S	---
	15 m	R88A-CAGA015S	---
	20 m	R88A-CAGA020S	---
	30 m	R88A-CAGA030S	---
	40 m	R88A-CAGA040S	---
	50 m	R88A-CAGA050S	---
3,000-r/min Servomotors of 1 to 1.5 kW, 2,000-r/min Servomotors of 1 to 1.5 kW, 1,000-r/min Servomotors of 900 W	3 m	R88A-CAGB003S	R88A-CAGB003B
	5 m	R88A-CAGB005S	R88A-CAGB005B
	10 m	R88A-CAGB010S	R88A-CAGB010B
	15 m	R88A-CAGB015S	R88A-CAGB015B
	20 m	R88A-CAGB020S	R88A-CAGB020B
	30 m	R88A-CAGB030S	R88A-CAGB030B
	40 m	R88A-CAGB040S	R88A-CAGB040B
	50 m	R88A-CAGB050S	R88A-CAGB050B
3,000-r/min Servomotors of 2 kW, 2,000-r/min Servomotors of 2 kW	3 m	R88A-CAGC003S	R88A-CAGC003B
	5 m	R88A-CAGC005S	R88A-CAGC005B
	10 m	R88A-CAGC010S	R88A-CAGC010B
	15 m	R88A-CAGC015S	R88A-CAGC015B
	20 m	R88A-CAGC020S	R88A-CAGC020B
	30 m	R88A-CAGC030S	R88A-CAGC030B
	40 m	R88A-CAGC040S	R88A-CAGC040B
	50 m	R88A-CAGC050S	R88A-CAGC050B
3,000-r/min Servomotors of 3 to 5 kW, 2,000-r/min Servomotors of 3 to 5 kW, 1,000-r/min Servomotors of 2 to 4.5 kW	3 m	R88A-CAGD003S	R88A-CAGD003B
	5 m	R88A-CAGD005S	R88A-CAGD005B
	10 m	R88A-CAGD010S	R88A-CAGD010B
	15 m	R88A-CAGD015S	R88A-CAGD015B
	20 m	R88A-CAGD020S	R88A-CAGD020B
	30 m	R88A-CAGD030S	R88A-CAGD030B
	40 m	R88A-CAGD040S	R88A-CAGD040B
	50 m	R88A-CAGD050S	R88A-CAGD050B

Specifications		Model	
		For Servomotor without brake	For Servomotor with brake
1,500-r/min Servomotors of 7.5 kW, 1,000-r/min Servomotors of 6 kW	3 m	R88A-CAGE003S	---
	5 m	R88A-CAGE005S	---
	10 m	R88A-CAGE010S	---
	15 m	R88A-CAGE015S	---
	20 m	R88A-CAGE020S	---
	30 m	R88A-CAGE030S	---
	40 m	R88A-CAGE040S	---
	50 m	R88A-CAGE050S	---

**Note** There are separate connectors for power and brakes for 3,000-r/min Servomotors of 50 to 750 W, Flat Servomotors, and Servomotors of 6 kW or higher. Therefore, when a Servomotor with a brake is used, it will require both a Power Cable for a Servomotor without a brake and a Brake Cable.

## 2-1 Standard Models

### ■ Brake Cables (Standard Cables)

Specifications	Model	
3,000-r/min Servomotors of 50 to 750 W, 3,000-r/min Flat Servomotors of 100 to 400 W	3 m	R88A-CAGA003B
	5 m	R88A-CAGA005B
	10 m	R88A-CAGA010B
	15 m	R88A-CAGA015B
	20 m	R88A-CAGA020B
	30 m	R88A-CAGA030B
	40 m	R88A-CAGA040B
	50 m	R88A-CAGA050B
1,500-r/min Servomotors of 7.5 kW, 1,000-r/min Servomotors of 6 kW	3 m	R88A-CAGE003B
	5 m	R88A-CAGE005B
	10 m	R88A-CAGE010B
	15 m	R88A-CAGE015B
	20 m	R88A-CAGE020B
	30 m	R88A-CAGE030B
	40 m	R88A-CAGE040B
	50 m	R88A-CAGE050B

■ Encoder Cables (Robot Cables)

Specifications	Model	
3,000-r/min Servomotors of 50 to 750 W with an absolute encoder, 3,000-r/min Flat Servomotors of 100 to 400 W with an absolute encoder	3 m	R88A-CRGA003CR
	5 m	R88A-CRGA005CR
	10 m	R88A-CRGA010CR
	15 m	R88A-CRGA015CR
	20 m	R88A-CRGA020CR
	30 m	R88A-CRGA030CR
	40 m	R88A-CRGA040CR
	50 m	R88A-CRGA050CR
3,000-r/min Servomotors of 50 to 750 W with an incremental encoder, 3,000-r/min Flat Servomotors of 100 to 400 W with an incremental encoder	3 m	R88A-CRGB003CR
	5 m	R88A-CRGB005CR
	10 m	R88A-CRGB010CR
	15 m	R88A-CRGB015CR
	20 m	R88A-CRGB020CR
	30 m	R88A-CRGB030CR
	40 m	R88A-CRGB040CR
	50 m	R88A-CRGB050CR
3,000-r/min Servomotors of 1 to 5 kW, 2,000-r/min Servomotors of 1 to 5 kW, 1,500-r/min Servomotors of 7.5 kW, 1,000-r/min Servomotors of 900 W to 6 kW	3 m	R88A-CRGC003NR
	5 m	R88A-CRGC005NR
	10 m	R88A-CRGC010NR
	15 m	R88A-CRGC015NR
	20 m	R88A-CRGC020NR
	30 m	R88A-CRGC030NR
	40 m	R88A-CRGC040NR
	50 m	R88A-CRGC050NR

■ Servomotor Power Cables (Robot Cables)

Specifications		Model	
		For Servomotor without brake	For Servomotor with brake
3,000-r/min Servomotors of 50 to 750 W, 3,000-r/min Flat Servomotors of 100 to 400 W	3 m	R88A-CAGA003SR	---
	5 m	R88A-CAGA005SR	---
	10 m	R88A-CAGA010SR	---
	15 m	R88A-CAGA015SR	---
	20 m	R88A-CAGA020SR	---
	30 m	R88A-CAGA030SR	---
	40 m	R88A-CAGA040SR	---
	50 m	R88A-CAGA050SR	---
3,000-r/min Servomotors of 1 to 1.5 kW, 2,000-r/min Servomotors of 1 to 1.5 kW, 1,000-r/min Servomotors of 900 W	3 m	R88A-CAGB003SR	R88A-CAGB003BR
	5 m	R88A-CAGB005SR	R88A-CAGB005BR
	10 m	R88A-CAGB010SR	R88A-CAGB010BR
	15 m	R88A-CAGB015SR	R88A-CAGB015BR
	20 m	R88A-CAGB020SR	R88A-CAGB020BR
	30 m	R88A-CAGB030SR	R88A-CAGB030BR
	40 m	R88A-CAGB040SR	R88A-CAGB040BR
	50 m	R88A-CAGB050SR	R88A-CAGB050BR
3,000-r/min Servomotors of 2 kW, 2,000-r/min Servomotors of 2 kW	3 m	R88A-CAGC003SR	R88A-CAGC003BR
	5 m	R88A-CAGC005SR	R88A-CAGC005BR
	10 m	R88A-CAGC010SR	R88A-CAGC010BR
	15 m	R88A-CAGC015SR	R88A-CAGC015BR
	20 m	R88A-CAGC020SR	R88A-CAGC020BR
	30 m	R88A-CAGC030SR	R88A-CAGC030BR
	40 m	R88A-CAGC040SR	R88A-CAGC040BR
	50 m	R88A-CAGC050SR	R88A-CAGC050BR
3,000-r/min Servomotors of 3 to 5 kW, 2,000-r/min Servomotors of 3 to 5 kW, 1,000-r/min Servomotors of 2 to 4.5 kW	3 m	R88A-CAGD003SR	R88A-CAGD003BR
	5 m	R88A-CAGD005SR	R88A-CAGD005BR
	10 m	R88A-CAGD010SR	R88A-CAGD010BR
	15 m	R88A-CAGD015SR	R88A-CAGD015BR
	20 m	R88A-CAGD020SR	R88A-CAGD020BR
	30 m	R88A-CAGD030SR	R88A-CAGD030BR
	40 m	R88A-CAGD040SR	R88A-CAGD040BR
	50 m	R88A-CAGD050SR	R88A-CAGD050BR

**Note** There are separate connectors for power and brakes for 3,000-r/min Servomotors of 50 to 750 W and Flat Servomotors.

Therefore, when a Servomotor with a brake is used, it will require a Power Cable for a Servomotor without a brake and a Brake Cable.

### ■ Brake Cables (Robot Cables)

Specifications		Model
3,000-r/min Servomotors of 50 to 750 W, 3,000-r/min Flat Servomotors of 100 to 400 W	3 m	R88A-CAGA003BR
	5 m	R88A-CAGA005BR
	10 m	R88A-CAGA010BR
	15 m	R88A-CAGA015BR
	20 m	R88A-CAGA020BR
	30 m	R88A-CAGA030BR
	40 m	R88A-CAGA040BR
	50 m	R88A-CAGA050BR

### ■ Communications Cable

Specifications		Model
RS-232 Communications Cable	2 m	R88A-CCG002P2
RS-485 Communications Cable	0.5 m	R88A-CCG0R5P4
	1 m	R88A-CCG001P4

### ■ Absolute Encoder Battery Cables

Specifications		Model
Absolute Encoder Battery Cable (battery not supplied)	0.3 m	R88A-CRGD0R3C
Absolute Encoder Battery Cable (R88A-BAT01G battery × 1 supplied)	0.3 m	R88A-CRGD0R3C-BS

### ■ Absolute Encoder Backup Battery

Specifications		Model
Absolute Encoder Backup Battery		R88A-BAT01G

### ■ Connectors

Specifications		Model
Servomotor Connector for Encoder Cable	Absolute Encoder	R88A-CNG01R
	Incremental Encoder	R88A-CNG02R
Control I/O Connector (CN1)		R88A-CNU11C
Encoder Connector (CN2)		R88A-CNW01R
Power Cable Connector (750 W max.)		R88A-CNG01A
Brake Cable Connector (750 W max.)		R88A-CNG01B

### ■ Servo Relay Units (for CN1)

Specifications		Model
Servo Relay Units	For CS1W-NC113/-NC133 For CJ1W-NC113/-NC133 For C200HW-NC113	XW2B-20J6-1B
	For CS1W-NC213/-NC413/-NC233/-NC433 For CJ1W-NC213/-NC413/-NC233/-NC433 For C200HW-NC213/-NC413	XW2B-40J6-2B
	For CJ1M-CPU21/-CPU22/-CPU23	XW2B-20J6-8A XW2B-40J6-9A
	For FQM1-MMA22 For FQM1-MMP22	XW2B-80J7-12A
	For CQM1-CPU43-V1	XW2B-20J6-3B

### ■ Servo Relay Unit Cables for Servo Drives

Specifications		Model	
Servo Drive Cables	For Position Control Unit (XW2B-□J6-□B) For CQM1 (XW2B-20J6-3B)	1 m	XW2Z-100J-B25
		2 m	XW2Z-200J-B25
	For CJ1M (XW2B-20J6-8A/XW2B-40J6-9A)	1 m	XW2Z-100J-B31
		2 m	XW2Z-200J-B31
	For FQM1-MMA22 (XW2B-80J7-12A)	1 m	XW2Z-100J-B27
		2 m	XW2Z-200J-B27
	For FQM1-MMP22 (XW2B-80J7-12A)	1 m	XW2Z-100J-B26
		2 m	XW2Z-200J-B26

**Note** Do not use a Servo Relay Unit Cable for line receiver inputs (+CWLD: CN1 pin 44, -CWLD: CN1 pin 45, +CCWLD: CN1 pin 46, -CCWLD: CN1 pin 47).  
Use a General-purpose Control Cable (R88A-CPG□S) and prepare wiring suited for the controller to be connected.



■ Servo Relay Unit Cables for Position Control Units

Specifications		Model	
Position Control Unit Cables	For CQM1-CPU43-V1 (XW2B-20J6-3B)	0.5 m	XW2Z-050J-A3
		1 m	XW2Z-100J-A3
	For CS1W-NC113, C200HW-NC113 (XW2B-20J6-1B)	0.5 m	XW2Z-050J-A6
		1 m	XW2Z-100J-A6
	For CS1W-NC213/-NC413, C200HW-NC213/-NC413 (XW2B-20J6-2B)	0.5 m	XW2Z-050J-A7
		1 m	XW2Z-100J-A7
	For CS1W-NC133 (XW2B-20J6-1B)	0.5 m	XW2Z-050J-A10
		1 m	XW2Z-100J-A10
	For CS1W-NC233/-NC433 (XW2B-20J6-2B)	0.5 m	XW2Z-050J-A11
		1 m	XW2Z-100J-A11
	For CJ1W-NC113 (XW2B-20J6-1B)	0.5 m	XW2Z-050J-A14
		1 m	XW2Z-100J-A14
	For CJ1W-NC213/-NC413 (XW2B-20J6-2B)	0.5 m	XW2Z-050J-A15
		1 m	XW2Z-100J-A15
	For CJ1W-NC133 (XW2B-20J6-1B)	0.5 m	XW2Z-050J-A18
		1 m	XW2Z-100J-A18
	For CJ1W-NC233/-NC433 (XW2B-20J6-2B)	0.5 m	XW2Z-050J-A19
		1 m	XW2Z-100J-A19
	For CJ1M-CPU21/-CPU22/-CPU23 (XW2B-20J6-8A/XW2B-40J6-9A)	0.5 m	XW2Z-050J-A33
		1 m	XW2Z-100J-A33
For FQM1-MMA22 (XW2B-80J7-12A)	General-purpose I/O Cables	0.5 m	XW2Z-050J-A28
		1 m	XW2Z-100J-A28
		2 m	XW2Z-200J-A28
	Special I/O Cables	0.5 m	XW2Z-050J-A31
		1 m	XW2Z-100J-A31
		2 m	XW2Z-200J-A31
For FQM1-MMP22 (XW2B-80J7-12A)	General-purpose I/O Cables	0.5 m	XW2Z-050J-A28
		1 m	XW2Z-100J-A28
		2 m	XW2Z-200J-A28
	Special I/O Cables	0.5 m	XW2Z-050J-A30
		1 m	XW2Z-100J-A30
		2 m	XW2Z-200J-A30

## ■ Control Cables

Specifications		Model
Motion Control Unit Cables for 1 axis CS1W-MC221-V1/-MC421-V1	1 m	R88A-CPG001M1
	2 m	R88A-CPG002M1
	3 m	R88A-CPG003M1
	5 m	R88A-CPG005M1
Motion Control Unit Cables for 2 axes CS1W-MC221-V1/-MC421-V1	1 m	R88A-CPG001M2
	2 m	R88A-CPG002M2
	3 m	R88A-CPG003M2
	5 m	R88A-CPG005M2
General-purpose Control Cables with Connector on One End	1 m	R88A-CPG001S
	2 m	R88A-CPG002S
Connector-Terminal Block Cables	1 m	XW2Z-100J-B24
	2 m	XW2Z-200J-B24
Connector Terminal Block	M3 screw type	XW2B-50G4
	M3.5 screw type	XW2B-50G5
	M3 screw type	XW2D-50G6

## ■ External Regeneration Resistors

Specifications	Model
Regeneration capacity: 20 W, 50 $\Omega$ (with 150°C thermal switch)	R88A-RR08050S
Regeneration capacity: 20 W, 100 $\Omega$ (with 150°C thermal switch)	R88A-RR080100S
Regeneration capacity: 70 W, 47 $\Omega$ (with 150°C thermal switch)	R88A-RR22047S1
Regeneration capacity: 180 W, 20 $\Omega$ (with 200°C thermal switch)	R88A-RR50020S

## ■ Reactors

Specifications	Model
R88D-GTA5L/-GT01H	3G3AX-DL2002
R88D-GT01L/-GT02H	3G3AX-DL2004
R88D-GT02L/-GT04H	3G3AX-DL2007
R88D-GT04L/-GT08H/-GT10H	3G3AX-DL2015
R88D-GT15H	3G3AX-DL2022
R88D-GT08H/-GT10H/-GT15H	3G3AX-AL2025
R88D-GT20H/-GT30H	3G3AX-AL2055
R88D-GT50H	3G3AX-AL2110
R88D-GT75H	3G3AX-AL2220

■ Mounting Brackets (L Brackets for Rack Mounting)

Specifications	Model
R88D-GTA5L/-GT01L/-GT01H/-GT02H	R88A-TK01G
R88D-GT02L/-GT04H	R88A-TK02G
R88D-GT04L/-GT08H	R88A-TK03G
R88D-GT10H/-GT15H	R88A-TK04G

■ Absolute Encoder Backup Battery

Specifications	Model
2,000 mA·h 3.6 V	R88A-BAT01G

# 2-2 External and Mounting Hole Dimensions

2

## Servo Drives

- Single-phase 100 VAC: R88D-GTA5L/-GT01L (50 to 100 W)  
Single-phase 200 VAC: R88D-GT01H/-GT02H (50 to 200 W)

### Wall Mounting

External Dimensions

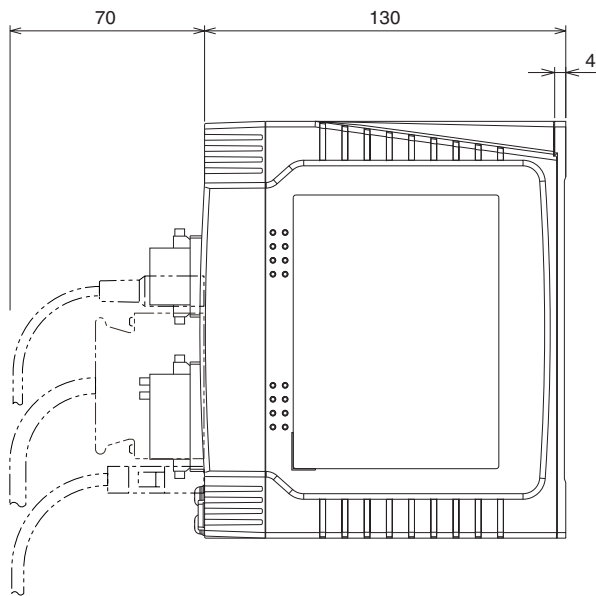
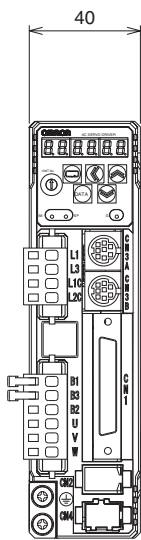

Mounting Hole Dimensions

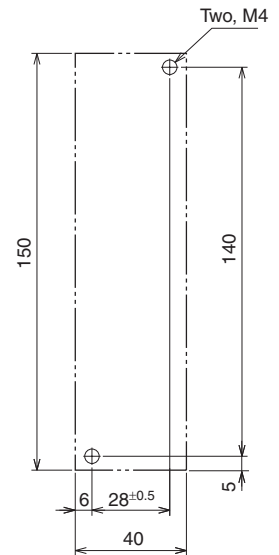

Standard Models and Dimensions

Front Panel Mounting (Using Mounting Brackets)

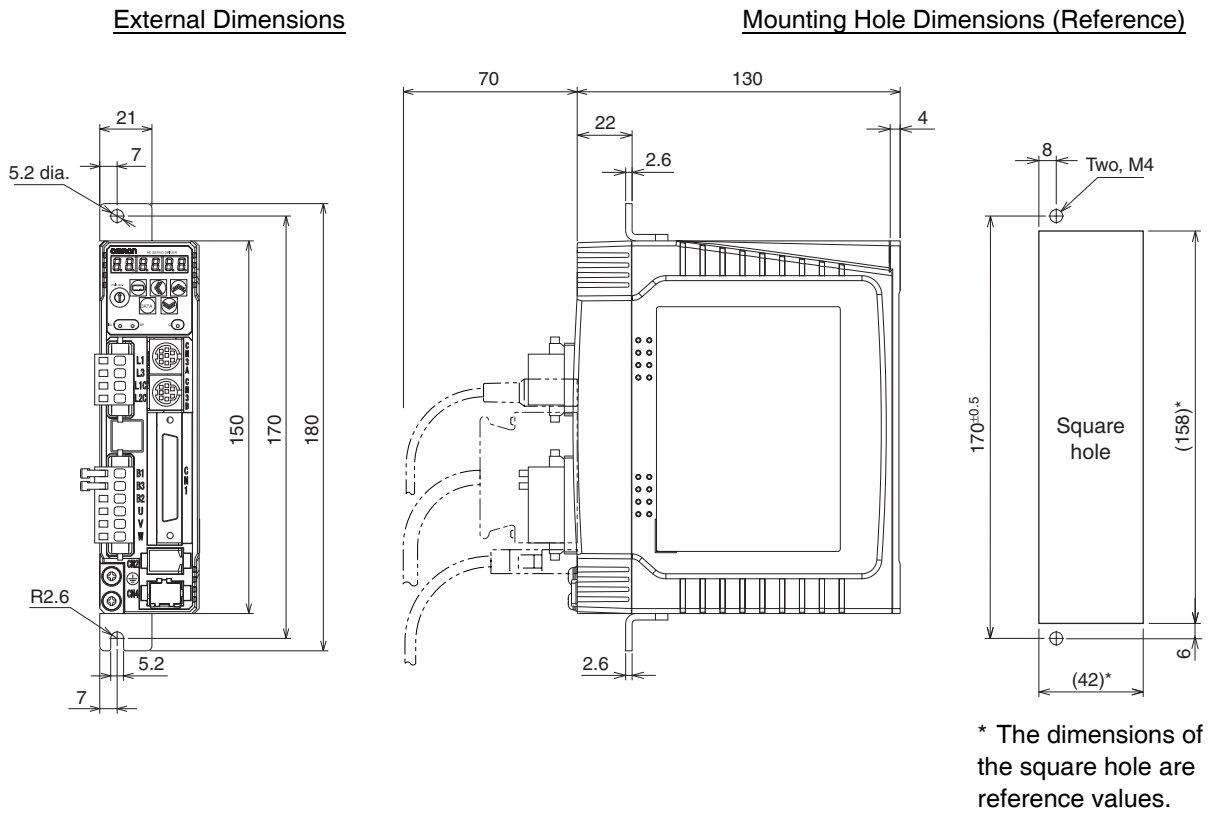

Dimensions for front panel mounting are reference values that provide leeway.

## 2-2 External and Mounting Hole Dimensions

- Single-phase 100 VAC: R88D-GT02L (200 W)
- Single-phase 200 VAC: R88D-GT04H (400 W)

### Wall Mounting

External Dimensions

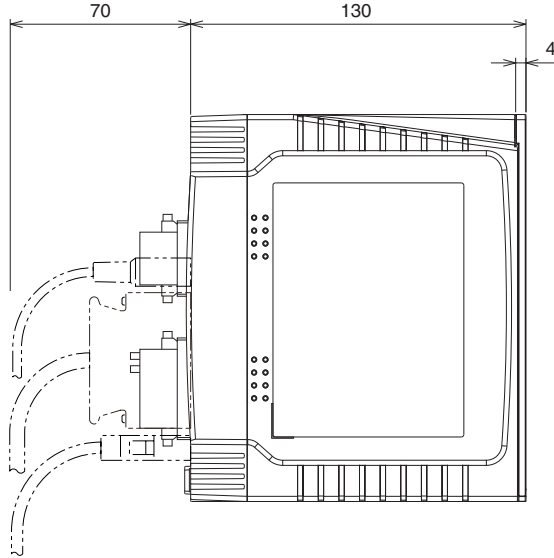
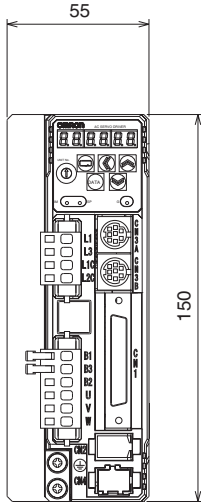

Mounting Hole Dimensions

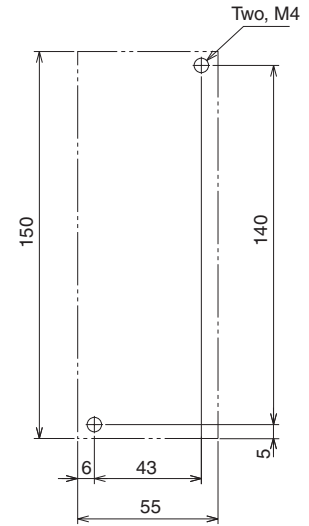

### Front Panel Mounting (Using Mounting Brackets)

External Dimensions

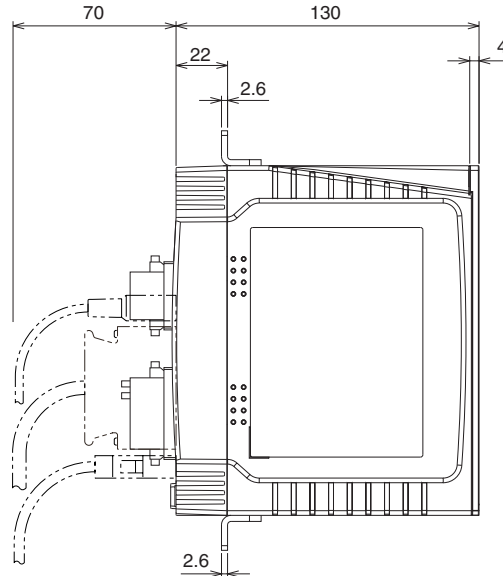
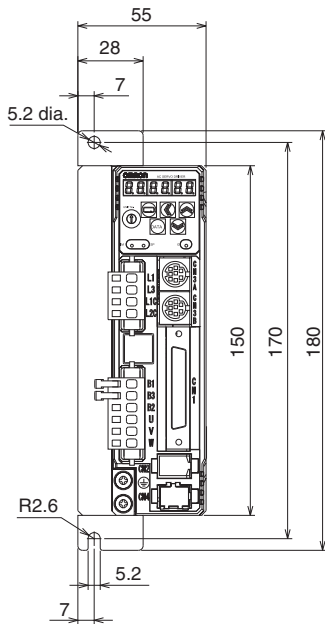

Mounting Hole Dimensions (Reference)

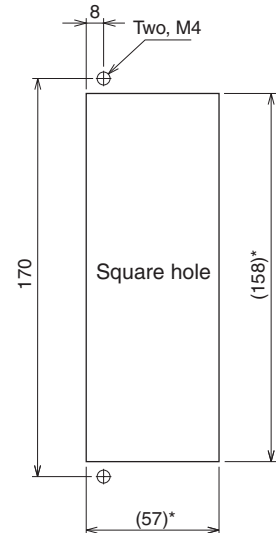

\* The dimensions of the square hole are reference values.

Dimensions for front panel mounting are reference values that provide leeway.

- Single-phase 100 VAC: R88D-GT04L (400 W)
- Single-phase/Three-phase 200 VAC: R88D-GT08H (750 W)

Wall Mounting

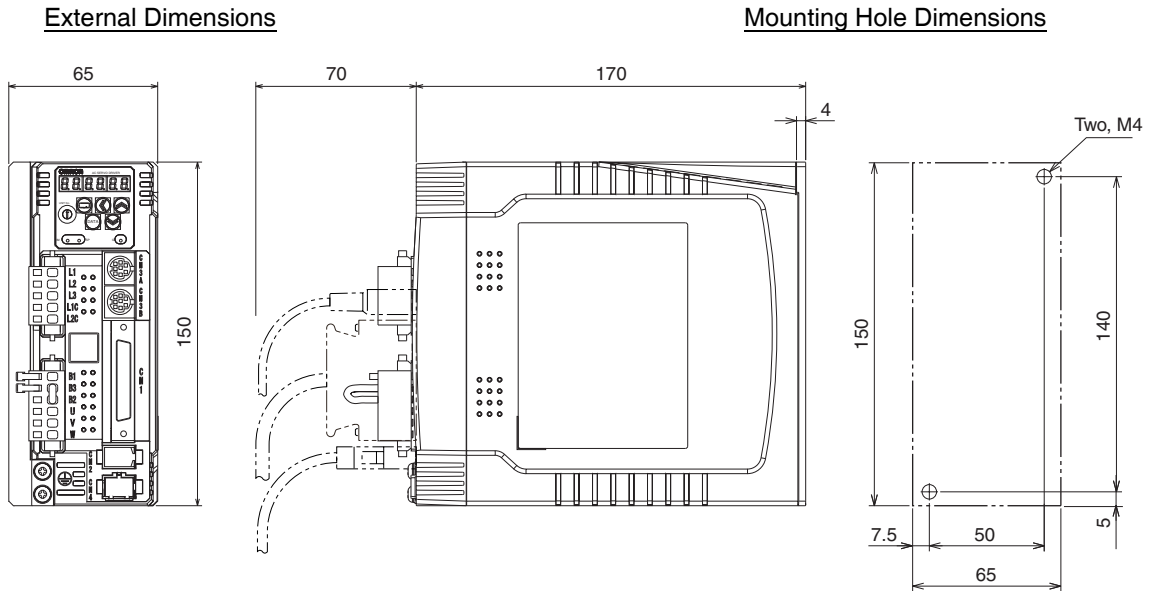

Front Panel Mounting (Using Mounting Brackets)

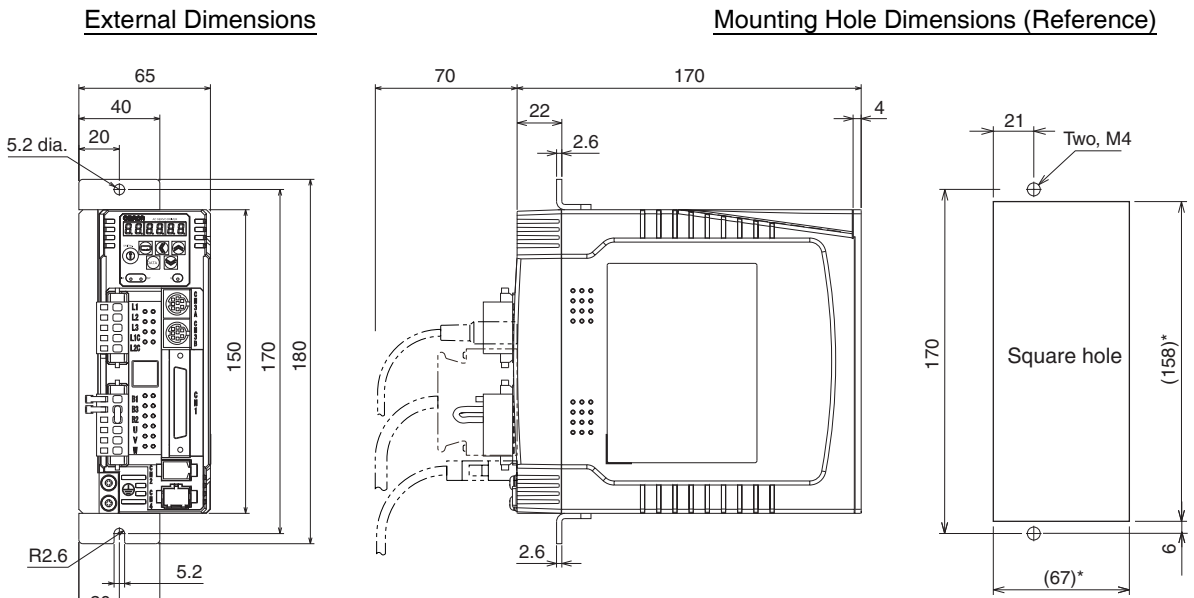

\* The dimensions of the square hole are reference values.

Dimensions for front panel mounting are reference values that provide leeway.

## 2-2 External and Mounting Hole Dimensions

### ■ Single-phase/Three-phase 200 VAC: R88D-GT10H/-GT15H (900 W to 1.5 kW)

#### Wall Mounting

External Dimensions

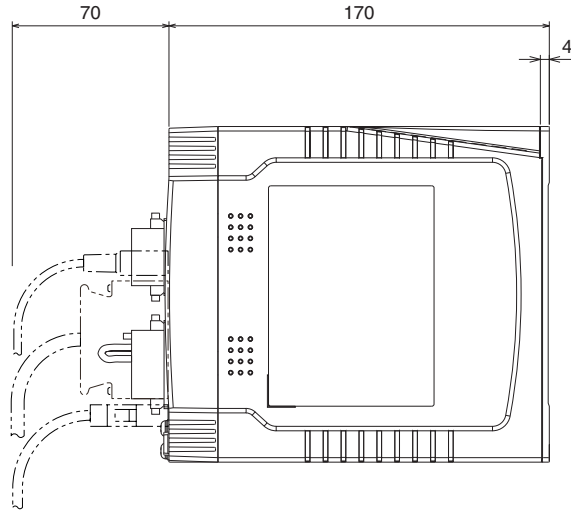
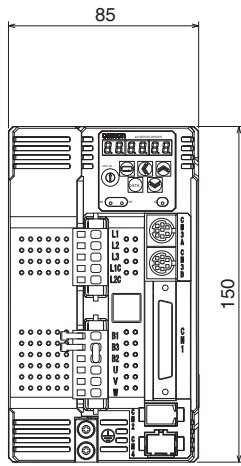

Mounting Hole Dimensions

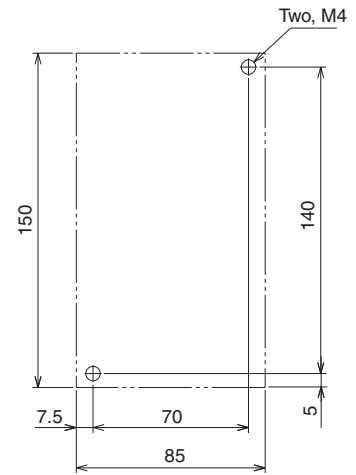

#### Front Panel Mounting (Using Mounting Brackets)

External Dimensions

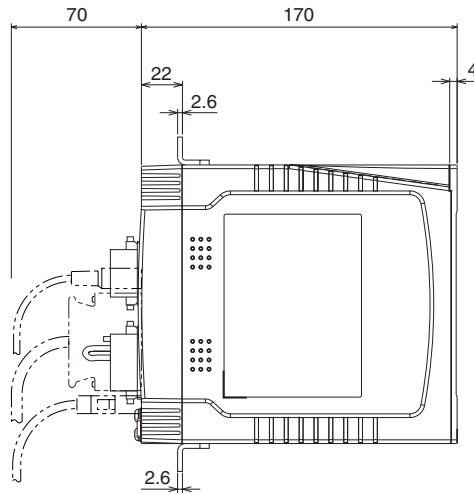
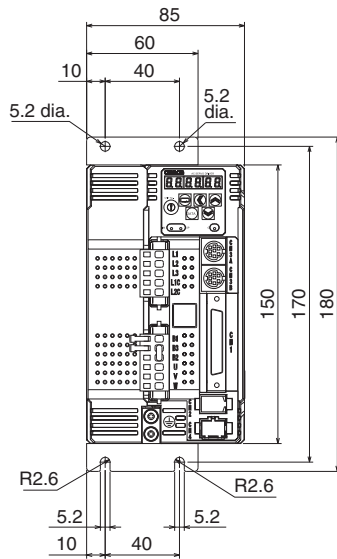

Mounting Hole Dimensions (Reference)

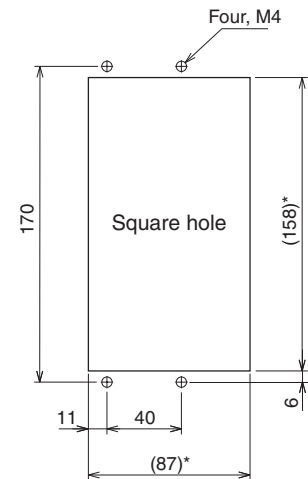

\* The dimensions of the square hole are reference values.

Dimensions for front panel mounting are reference values that provide leeway.



■ Three-phase 200 VAC: R88D-GT20H (2 kW)

Wall Mounting

External Dimensions

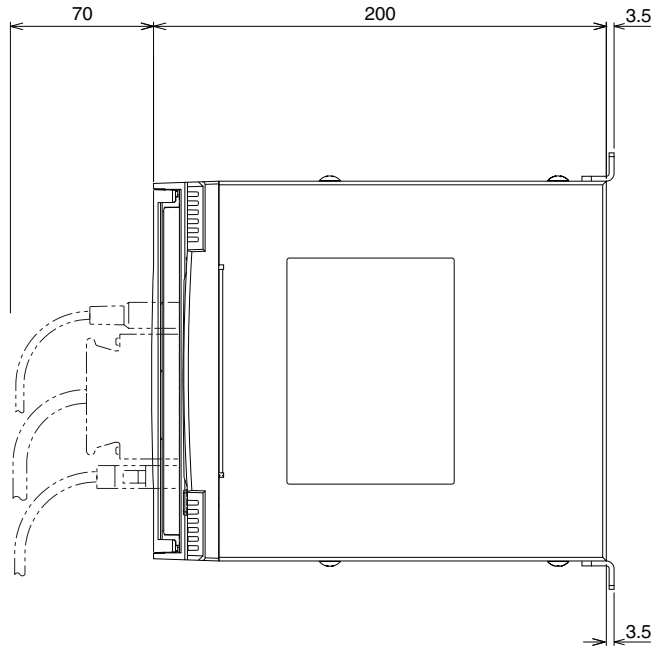
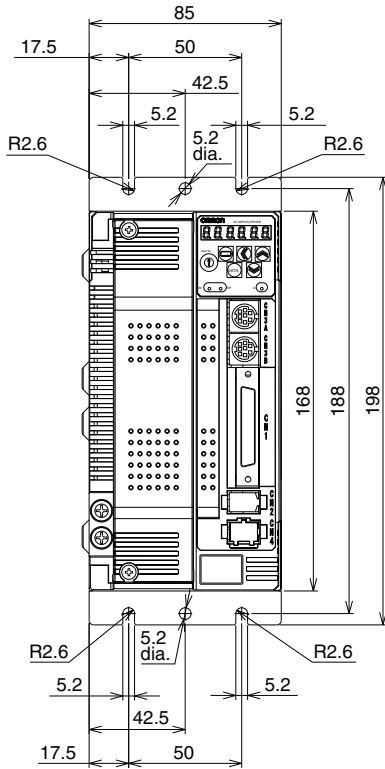

Mounting Hole Dimensions

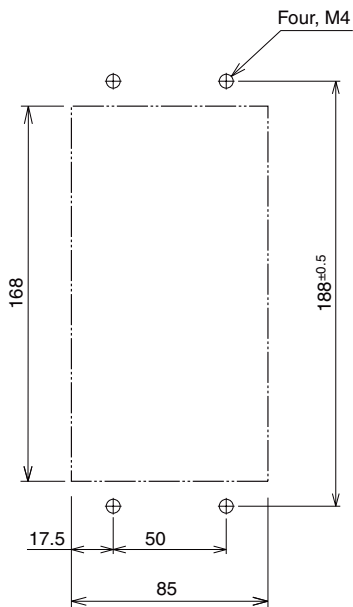

## 2-2 External and Mounting Hole Dimensions

### Front Panel Mounting (Using Mounting Brackets)

#### External Dimensions

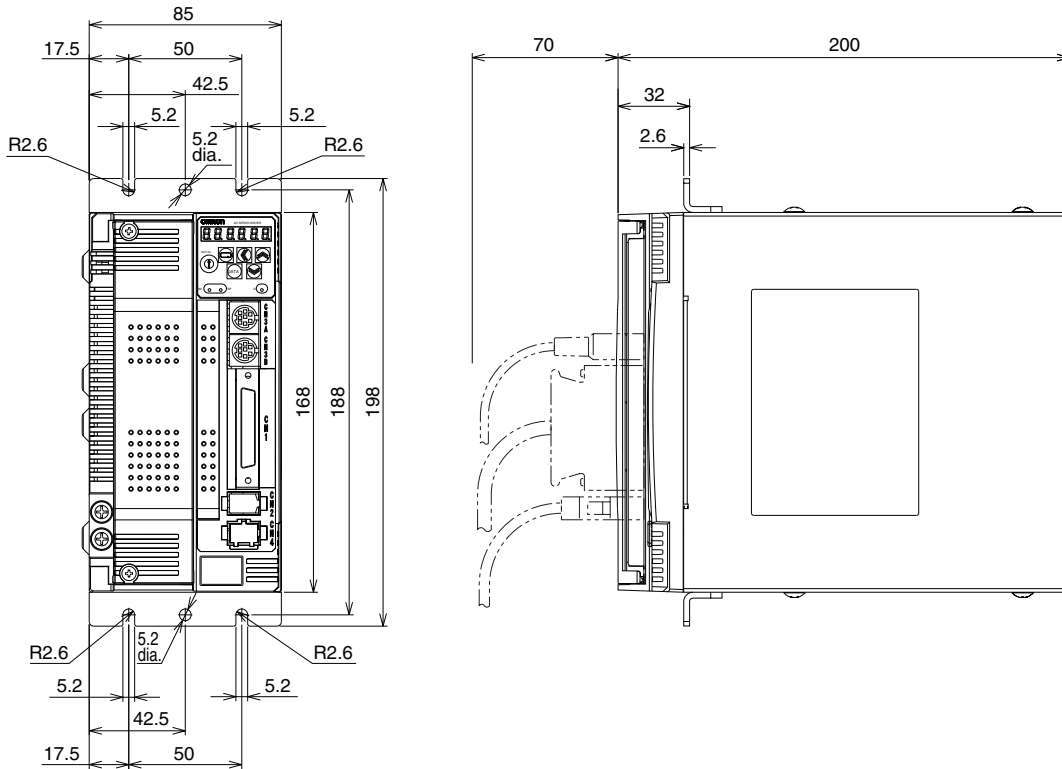

#### Mounting Hole Dimensions (Reference)

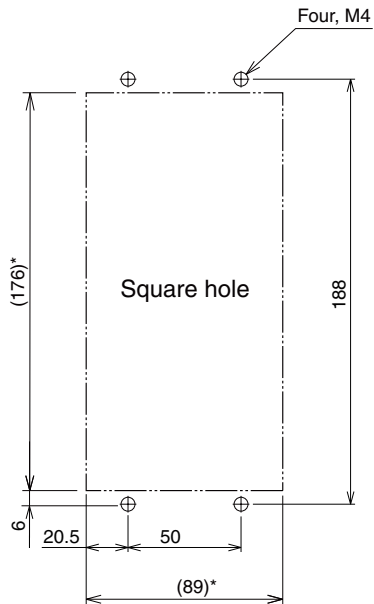

\* The dimensions of the square hole are reference values.

Dimensions for front panel mounting are reference values that provide leeway.

■ Three-phase 200 VAC: R88D-GT30H/-GT50H (2 to 5 kW)

Wall Mounting

External Dimensions

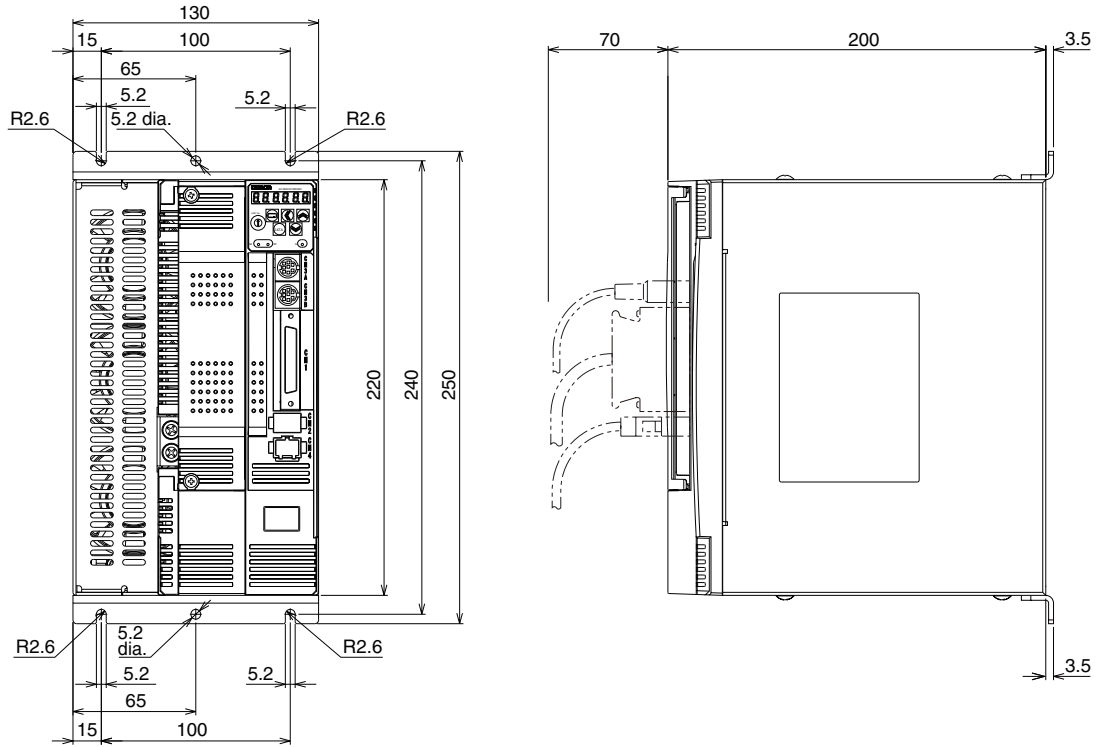

Mounting Hole Dimensions

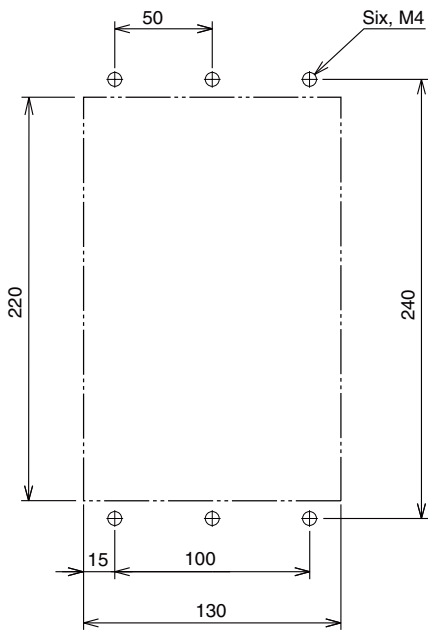

## 2-2 External and Mounting Hole Dimensions

### Front Panel Mounting (Using Mounting Brackets)

#### External Dimensions

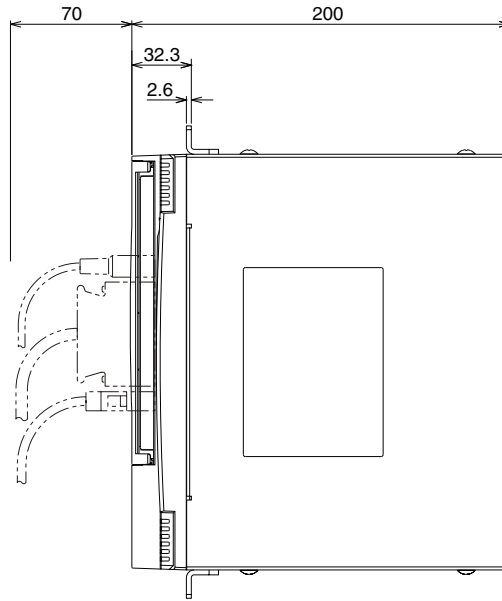
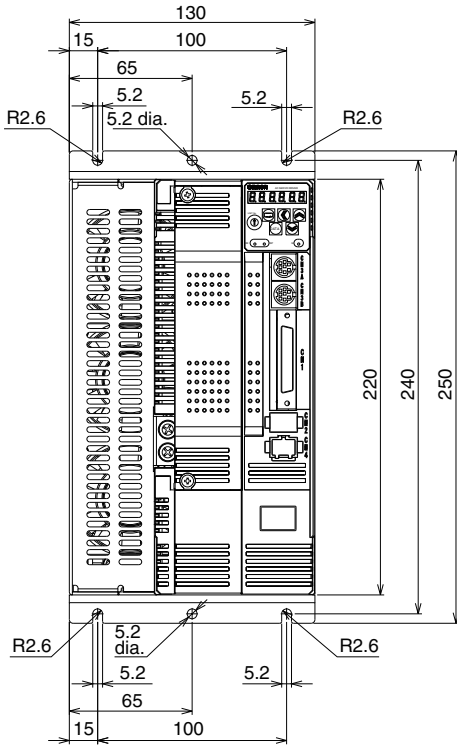

#### Mounting Hole Dimensions (Reference)

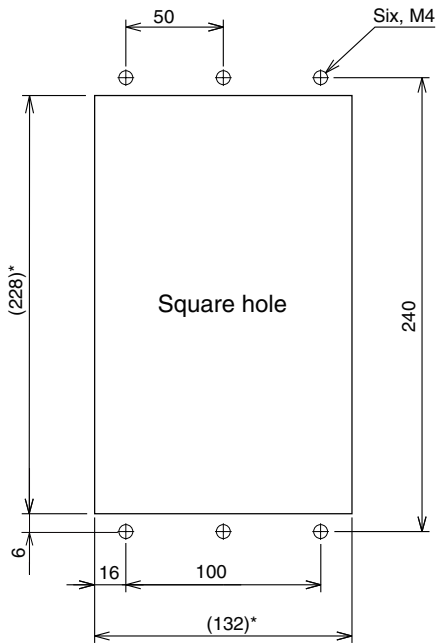

\* The dimensions of the square hole are reference values.

Dimensions for front panel mounting are reference values that provide leeway.

■ Three-phase 200 VAC: R88D-GT75H (7.5 kW)

Front Panel Mounting (Using Mounting Brackets)

External Dimensions

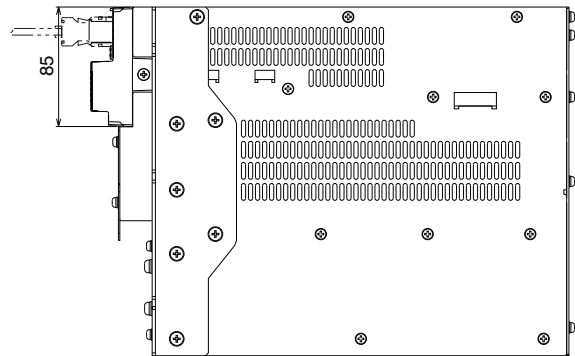
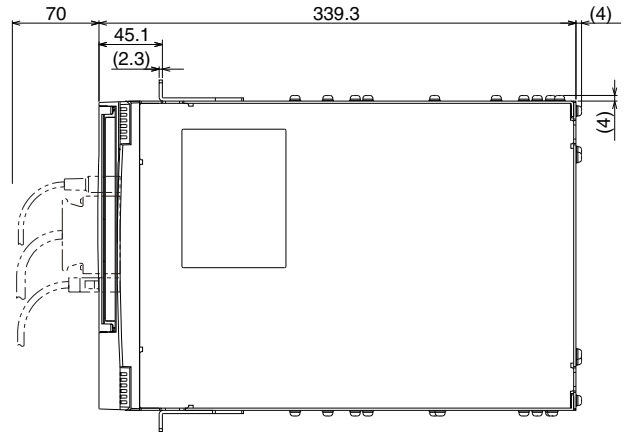
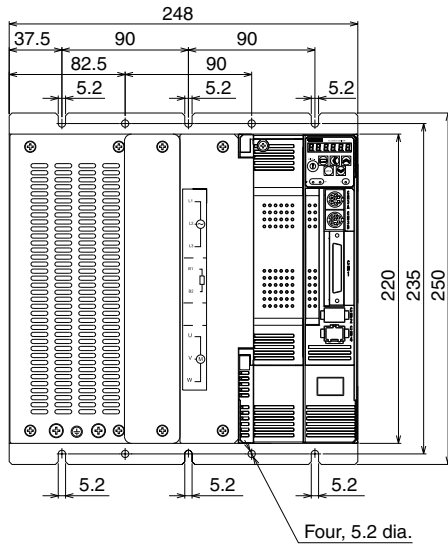

Mounting Hole Dimensions (Reference)

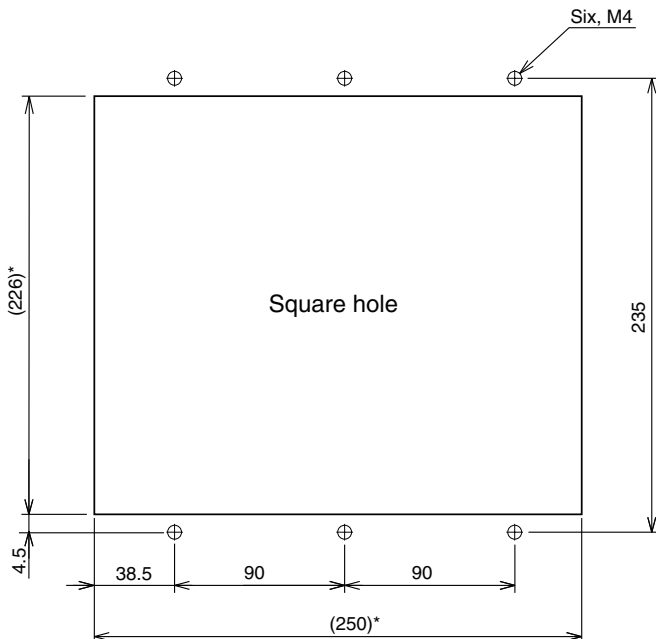

\* The dimensions of the square hole are reference values.

Dimensions for front panel mounting are reference values that provide leeway.

Servomotors

■ 3,000-r/min Servomotors

50 W/100 W

R88M-G05030H(-S2)/-G10030L(-S2)/-G10030H(-S2)/-G05030H-B(S2)

/-G10030L-B(S2)/-G10030H-B(S2) **INC**

R88M-G05030T(-S2)/-G10030S(-S2)/-G10030T(-S2)/-G05030T-B(S2)

/-G10030S-B(S2)/-G10030T-B(S2) **ABS**

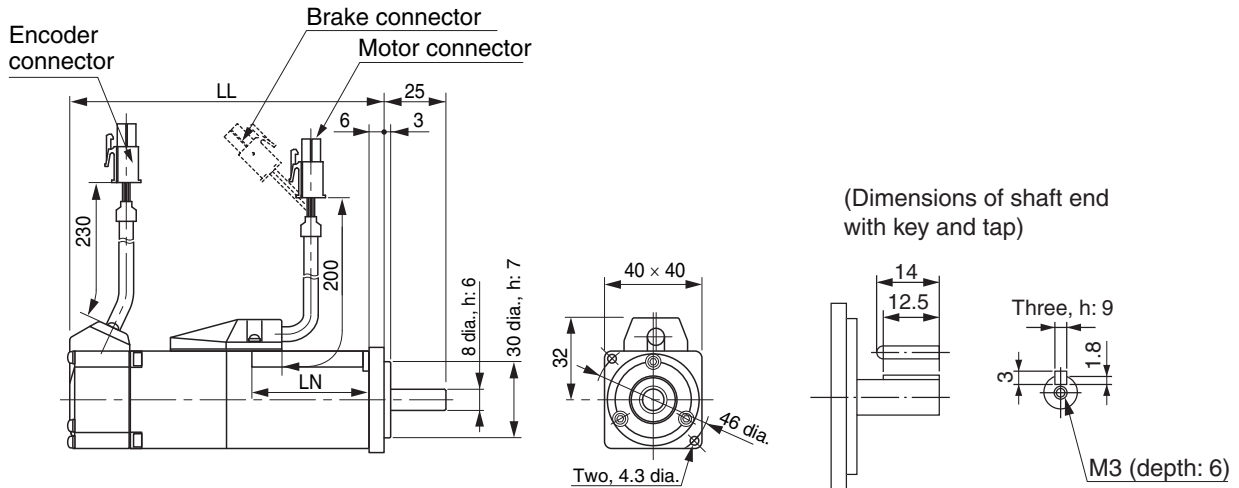

Model	Dimensions (mm)	
	LL	LN
R88M-G05030□	72	26.5
R88M-G10030□	92	46.5
R88M-G05030□-B□	102	26.5
R88M-G10030□-B□	122	46.5

**Note** The standard models have a straight shaft. Models with a key and tap are indicated with "S2" at the end of the model number.

■ 3,000-r/min Servomotors

200 W/400 W/750 W

R88M-G20030L(-S2)/-G40030L(-S2)/-G20030H(-S2)/-G40030H(-S2)

/-G75030H(-S2)/-G20030L-B(S2)/-G40030L-B(S2)

/-G20030H-B(S2)/-G40030H-B(S2)/-G75030H-B(S2) **INC**

R88M-G20030S(-S2)/-G40030S(-S2)/-G20030T(-S2)/-G40030T(-S2)

/-G75030T(-S2)/-G20030S-B(S2)/-G40030S-B(S2)

/-G20030T-B(S2)/-G40030T-B(S2)/-G75030T-B(S2) **ABS**

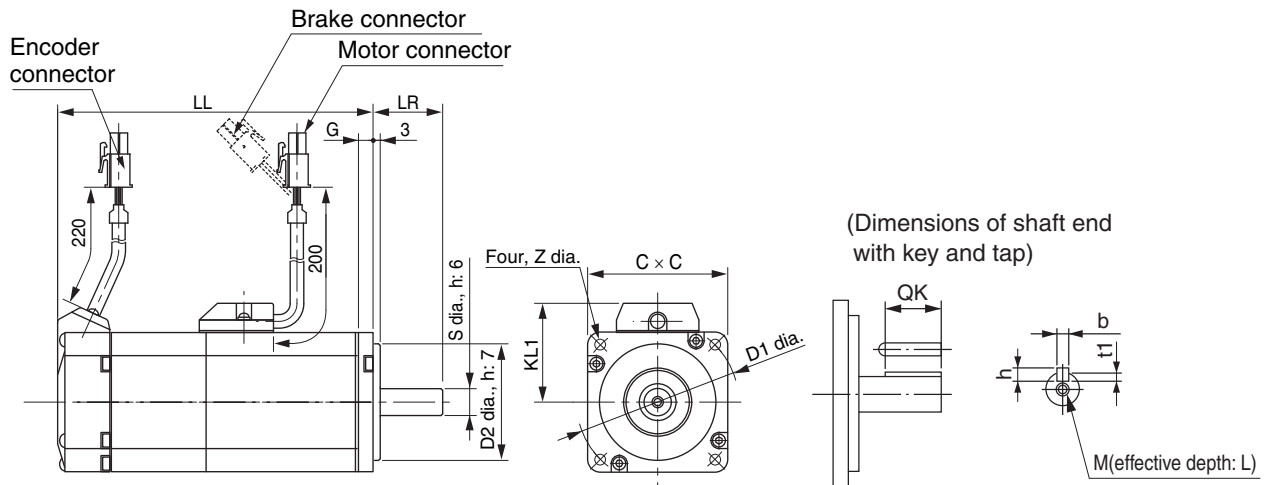

Model	Dimensions (mm)														
	LL	LR	S	D1	D2	C	G	KL1	Z	QK	b	h	M	t1	L
R88M-G20030□	79.5	30	11	70	50	60	6.5	43	4.5	18	4h9	4	M4	2.5	8
R88M-G40030□	99		14							22.5	5h9	5		M5	
R88M-G75030□	112.2	35	19	90	70	80	8	53	6	22	6h9	6	M5		3.5
R88M-G20030□-B□	116	30	11	70	50	60	6.5	43	4.5	18	4h9	4		M4	2.5
R88M-G40030□-B□	135.5		14							22.5	5h9	5	M5		3
R88M-G75030□-B□	149.2	35	19	90	70	80	8	53	6	22	6h9	6		M5	3.5

**Note** The standard models have a straight shaft. Models with a key and tap are indicated with "S2" at the end of the model number.

## 2-2 External and Mounting Hole Dimensions

### ■ 3,000-r/min Servomotors

#### 1 kW/1.5 kW/2 kW

R88M-G1K030T(-S2)/-G1K530T(-S2)/-G2K030T(-S2)/-G1K030T-B(S2)

/-G1K530T-B(S2)/-G2K030T-B(S2) **ABS**

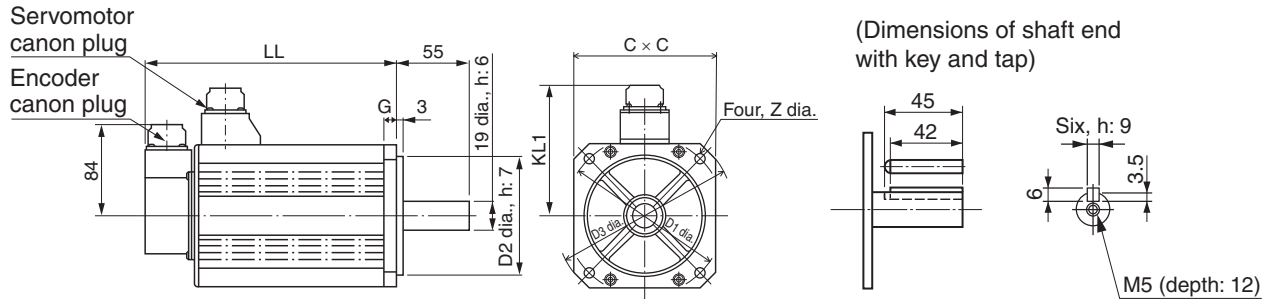

Model	Dimensions (mm)							
	LL	D1	D2	C	D3	G	KL1	Z
R88M-G1K030□	175	100	80	90	120	7	98	6.6
R88M-G1K530□	180	115	95	100	135	10	103	9
R88M-G2K030□	205							
R88M-G1K030□-B□	200	100	80	90	120	7	98	6.6
R88M-G1K530□-B□	205	115	95	100	135	10	103	9
R88M-G2K030□-B□	230							

**Note** The standard models have a straight shaft. Models with a key and tap are indicated with "S2" at the end of the model number.

### ■ 3,000-r/min Servomotors

#### 3 kW

R88M-G3K030T(-S2)/-G3K030T-B(S2) **ABS**

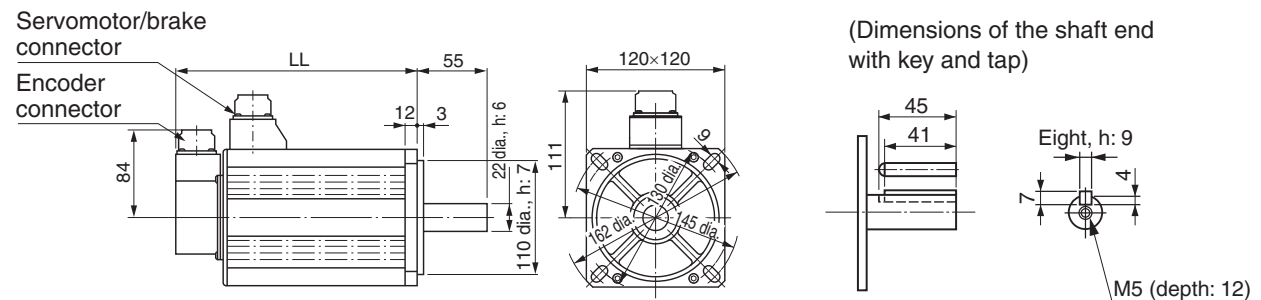

Model	Dimensions (mm)
	LL
R88M-G3K030□	217
R88M-G3K030□-B□	242

**Note** The standard models have a straight shaft. Models with a key and tap are indicated with "S2" at the end of the model number.



■ 3,000-r/min Servomotors

4 kW/5 kW

R88M-G4K030T(-S2)/-G5K030T(-S2)/-G4K030T-B(S2)/-G5K030T-B(S2)

ABS

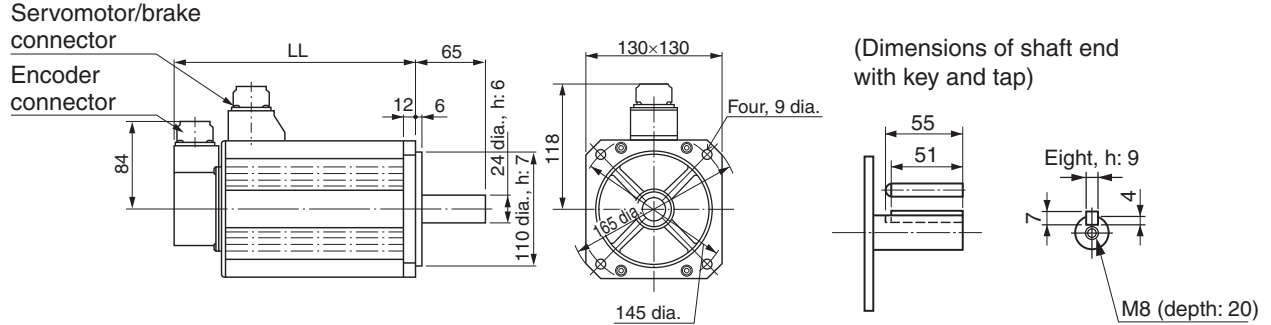

Model	Dimensions (mm)
	LL
R88M-G4K030□	240
R88M-G5K030□	280
R88M-G4K030□-B□	265
R88M-G5K030□-B□	305

**Note** The standard models have a straight shaft. Models with a key and tap are indicated with "S2" at the end of the model number.

## 2-2 External and Mounting Hole Dimensions

### ■ 3,000-r/min Flat Servomotors

#### 100 W/200 W/400 W

R88M-GP10030L(-S2)/-GP20030L(-S2)/-GP40030L(-S2)/-GP10030H(-S2)  
 /-GP20030H(-S2)/-GP40030H(-S2)/-GP10030L-B(S2)/-GP20030L-B(S2)  
 /-GP40030L-B(S2)/-GP10030H-B(S2)/-GP20030H-B(S2)/-GP40030H-B(S2)

INC

R88M-GP10030S(-S2)/-GP20030S(-S2)/-GP40030S(-S2)/-GP10030T(-S2)  
 /-GP20030T(-S2)/-GP40030T(-S2)/-GP10030S-B(S2)/-GP20030S-B(S2)  
 /-GP40030S-B(S2)/-GP10030T-B(S2)/-GP20030T-B(S2)/-GP40030T-B(S2)

ABS

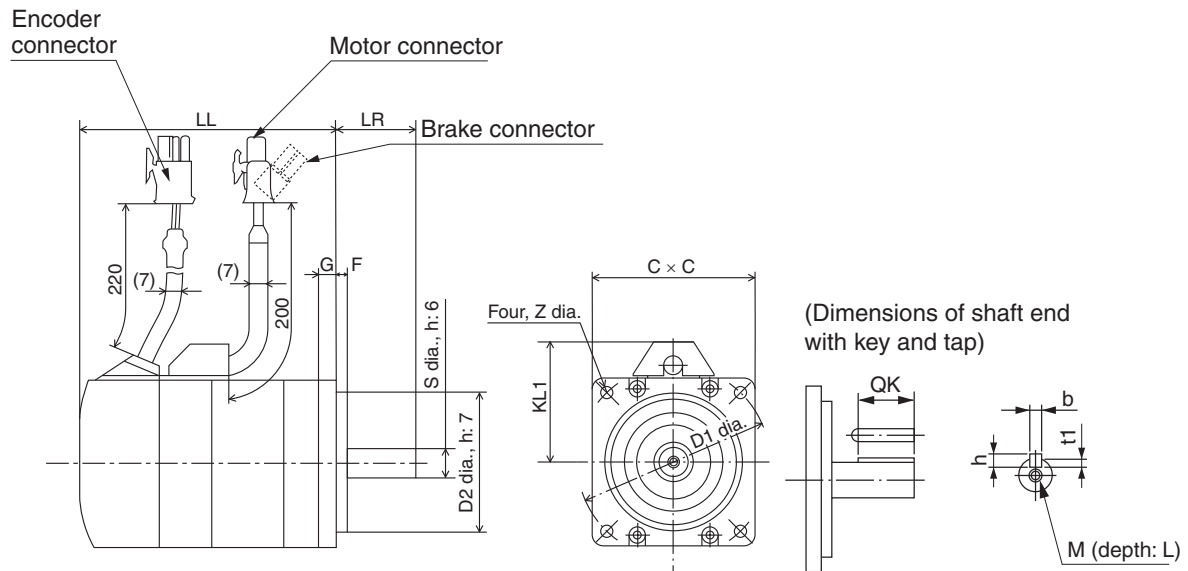

Model	Dimensions (mm)															
	LL	LR	S	D1	D2	C	F	G	KL1	Z	QK	b	h	t1	M	L
R88M-GP10030L R88M-GP10030H	60.5	25	8	70	50	60	3	7	43	4.5	12.5	3h9	3	1.8	M3	6
R88M-GP10030S R88M-GP10030T																
R88M-GP20030L R88M-GP20030H	67.5	30	11	90	70	80	5	8	53	5.5	18	4h9	4	2.5	M4	8
R88M-GP20030S R88M-GP20030T																
R88M-GP40030L R88M-GP40030H	82.5	30	14	90	70	80	5	8	53	5.5	22.5	5h9	5	3	M5	10
R88M-GP40030S R88M-GP40030T																
R88M-GP10030L-B□ R88M-GP10030H-B□	84.5	25	8	70	50	60	3	7	43	4.5	12.5	3h9	3	1.8	M3	6
R88M-GP10030S-B□ R88M-GP10030T-B□																
R88M-GP20030L-B□ R88M-GP20030H-B□	100	30	11	90	70	80	5	8	53	5.5	18	4h9	4	2.5	M4	8
R88M-GP20030S-B□ R88M-GP20030T-B□																
R88M-GP40030L-B□ R88M-GP40030H-B□	115	30	14	90	70	80	5	8	53	5.5	22.5	5h9	5	3	M5	10
R88M-GP40030S-B□ R88M-GP40030T-B□																

**Note** The standard models have a straight shaft. Models with a key and tap are indicated with "S2" at the end of the model number.

■ 2,000-r/min Servomotors

1 kW/1.5 kW

R88M-G1K020T(-S2)/-G1K520T(-S2)/-G1K020T-B(S2)/-G1K520T-B(S2)

ABS

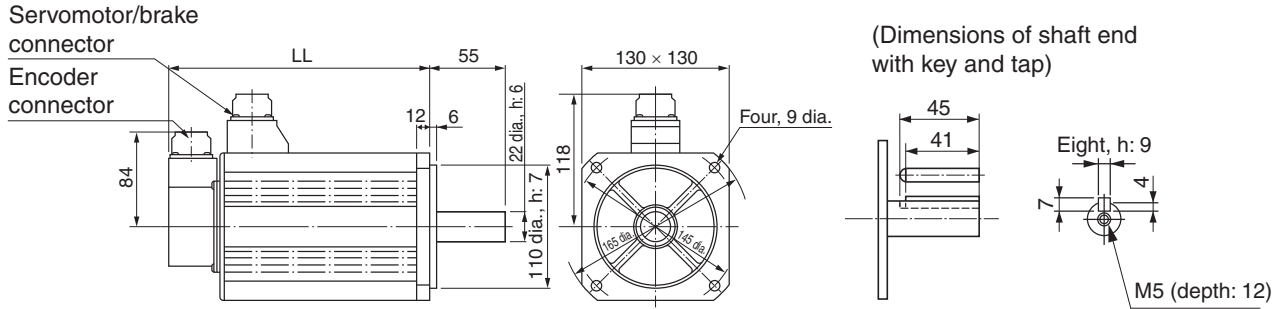

Model	Dimensions (mm)
	LL
R88M-G1K020□	150
R88M-G1K520□	175
R88M-G1K020□-B□	
R88M-G1K520□-B□	200

**Note** The standard models have a straight shaft. Models with a key and tap are indicated with “S2” at the end of the model number.

■ 2,000-r/min Servomotors

2 kW/3 kW

R88M-G2K020T(-S2)/-G3K020T(-S2)/-G2K020T-B(S2)/-G3K020T-B(S2)

ABS

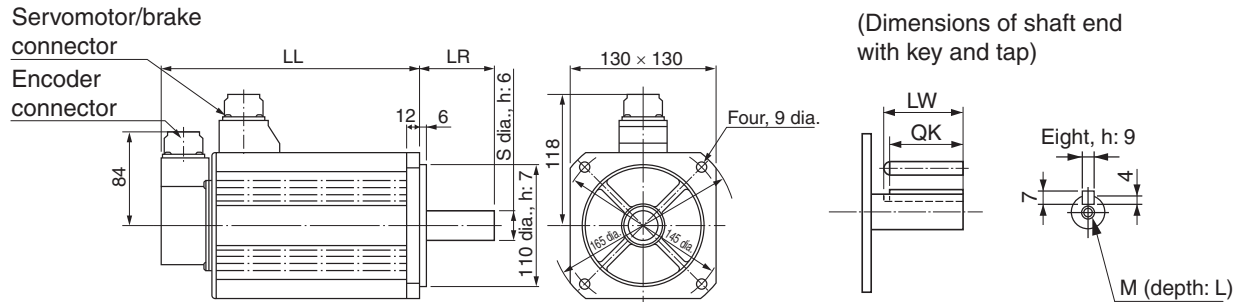

Model	Dimensions (mm)						
	LL	LR	S	LW	QK	M	L
R88M-G2K020□	200	55	22	45	41	M5	12
R88M-G3K020□	250	65	24	55	51	M8	20
R88M-G2K020□-B□	225	55	22	45	41	M5	12
R88M-G3K020□-B□	275	65	24	55	51	M8	20

**Note** The standard models have a straight shaft. Models with a key and tap are indicated with “S2” at the end of the model number.

## 2-2 External and Mounting Hole Dimensions

### ■ 2,000-r/min Servomotors

#### 4 kW/5 kW

R88M-G4K020T(-S2)/-G5K020T(-S2)/-G4K020T-B(S2)/-G5K020T-B(S2)

**ABS**

Servomotor/brake  
connector  
Encoder  
connector

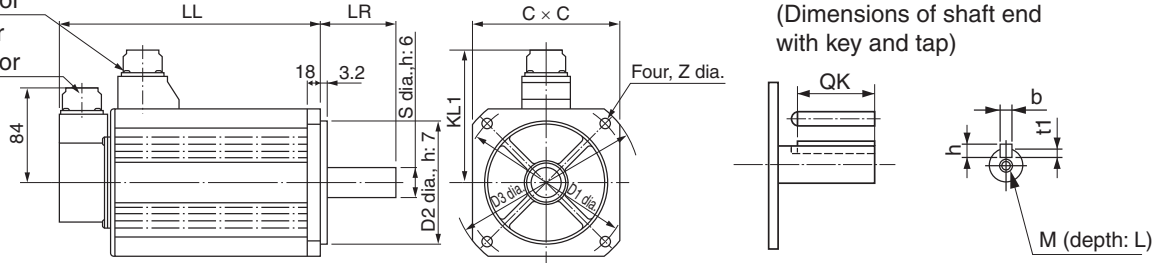

Model	Dimensions (mm)														
	LL	LR	S	D1	D2	C	D3	KL1	Z	QK	b	h	t1	M	L
R88M-G4K020□	242	65	28	165	130	150	190	128	11	51	8h9	7	4	M8	20
R88M-G5K020□	225	70	35	200	114.3	176	233	143	13.5	50	10h9	8	5	M12	25
R88M-G4K020□-B□	267	65	28	165	130	150	190	128	11	51	8h9	7	4	M8	20
R88M-G5K020□-B□	250	70	35	200	114.3	176	233	143	13.5	50	10h9	8	5	M12	25

**Note** The standard models have a straight shaft. Models with a key and tap are indicated with "S2" at the end of the model number.

■ 1,500-r/min Servomotors

7.5 kW

R88M-G7K515T(-S2)/-G7K515T-B(S2) **ABS**

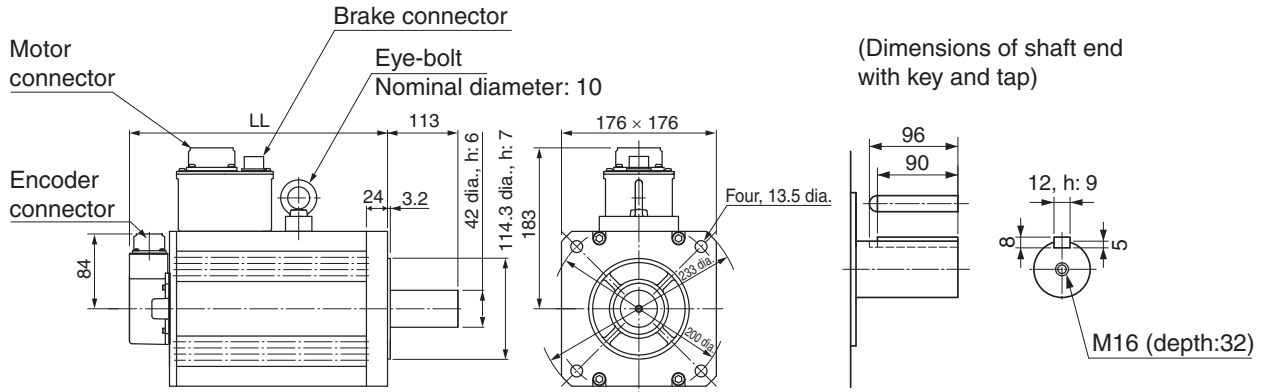

Model	Dimensions (mm)
	LL
R88M-G7K515□	340.5
R88M-G7K515□-B□	380.5

**Note** The standard models have a straight shaft. Models with a key and tap are indicated with "S2" at the end of the model number.

## 2-2 External and Mounting Hole Dimensions

### ■ 1,000-r/min Servomotors

900 W/2 kW

R88M-G90010T(-S2)/-G2K010T(-S2)/-G90010T-B(S2)/-G2K010T-B(S2)

**ABS**

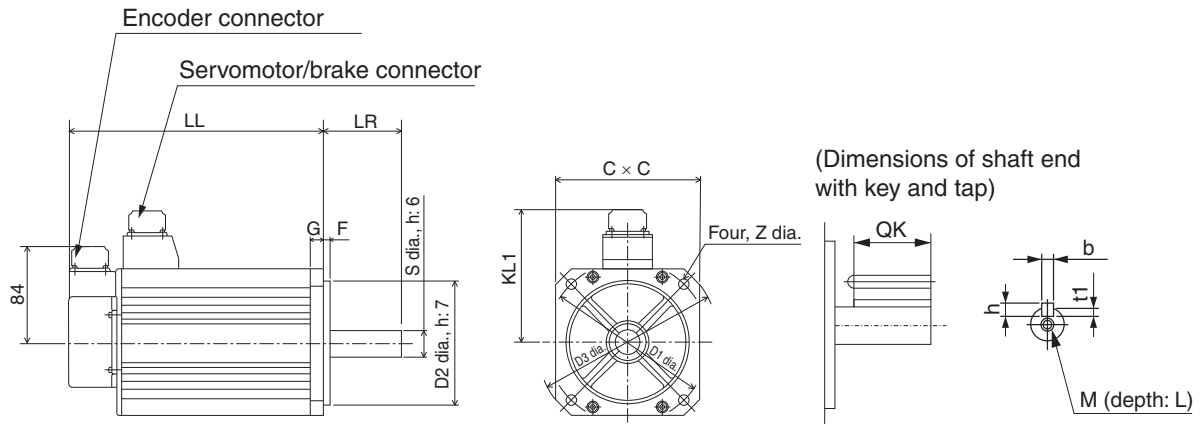

Model	Dimensions (mm)																
	LL	LR	S	D1	D2	C	D3	F	G	KL1	Z	QK	b	h	t1	M	L
R88M-G90010□	175	70	22	145	110	130	165	6	12	118	9	41	8h9	7	4	M5	12
R88M-G2K010□	182	80	35	200	114.3	176	233	3.2	18	143	13.5	50	10h9	8	5	M12	25
R88M-G90010□-B□	200	70	22	145	110	130	165	6	12	118	9	41	8h9	7	4	M5	12
R88M-G2K010□-B□	207	80	35	200	114.3	176	233	3.2	18	143	13.5	50	10h9	8	5	M12	25

**Note** The standard models have a straight shaft. Models with a key and tap are indicated with "S2" at the end of the model number.

### ■ 1,000-r/min Servomotors

3 kW

R88M-G3K010T(-S2)/-G3K010T-B(S2)

**ABS**

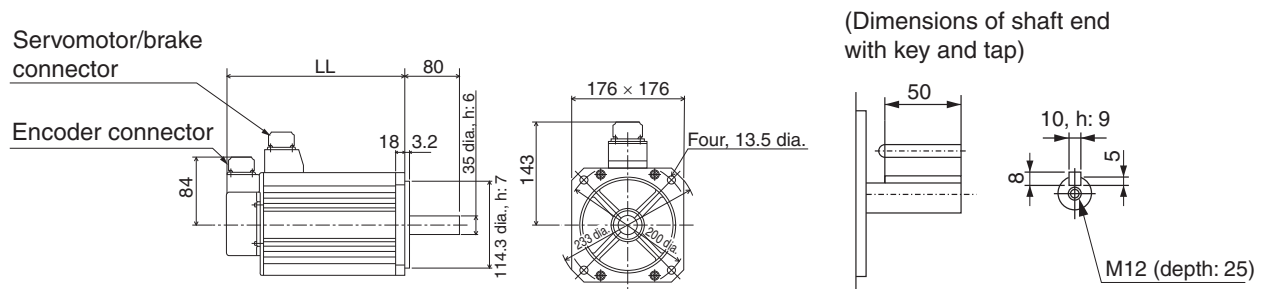

Model	Dimensions (mm)
	LL
R88M-G3K010□	222
R88M-G3K010□-B□	271

**Note** The standard models have a straight shaft. Models with a key and tap are indicated with "S2" at the end of the model number.

■ 1,000-r/min Servomotors

4.5 kW

R88M-G4K510T(-S2)/-G4K510T-B(S2) **ABS**

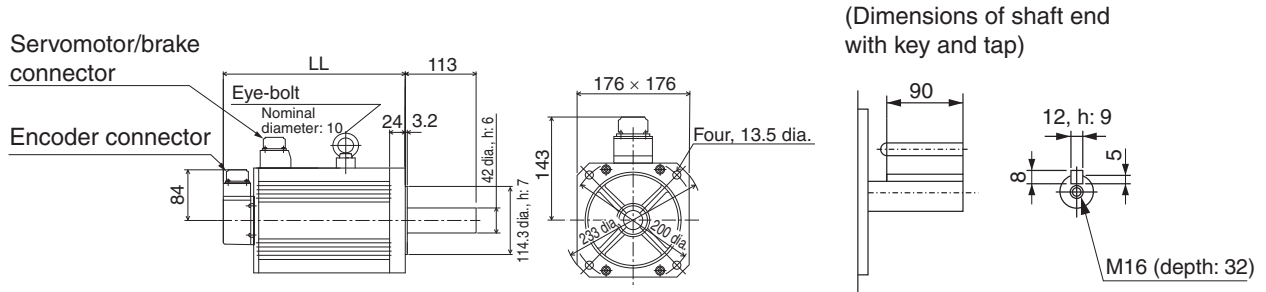

Model	Dimensions (mm)
	LL
R88M-G4K510□	300.5
R88M-G4K510□-B□	337.5

**Note** The standard models have a straight shaft. Models with a key and tap are indicated with “S2” at the end of the model number.

■ 1,000-r/min Servomotors

6 kW

R88M-G6K010T(-S2)/-G6K010T-B(S2) **ABS**

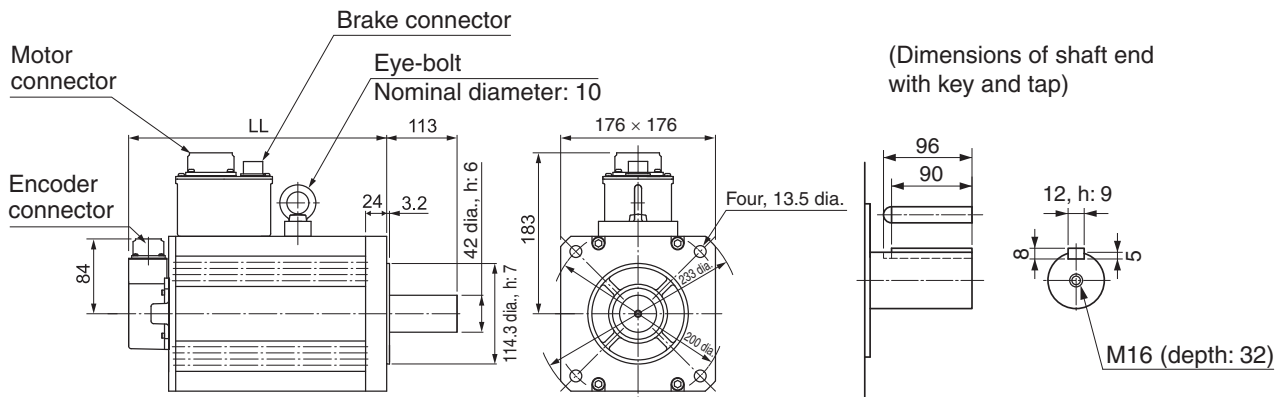

Model	Dimensions (mm)
	LL
R88M-G6K010□	340.5
R88M-G6K010□-B□	380.5

**Note** The standard models have a straight shaft. Models with a key and tap are indicated with “S2” at the end of the model number.

## Parameter Unit Dimensions

### ■ R88A-PR02G Hand-held Parameter Unit

2

Standard Models and Dimensions

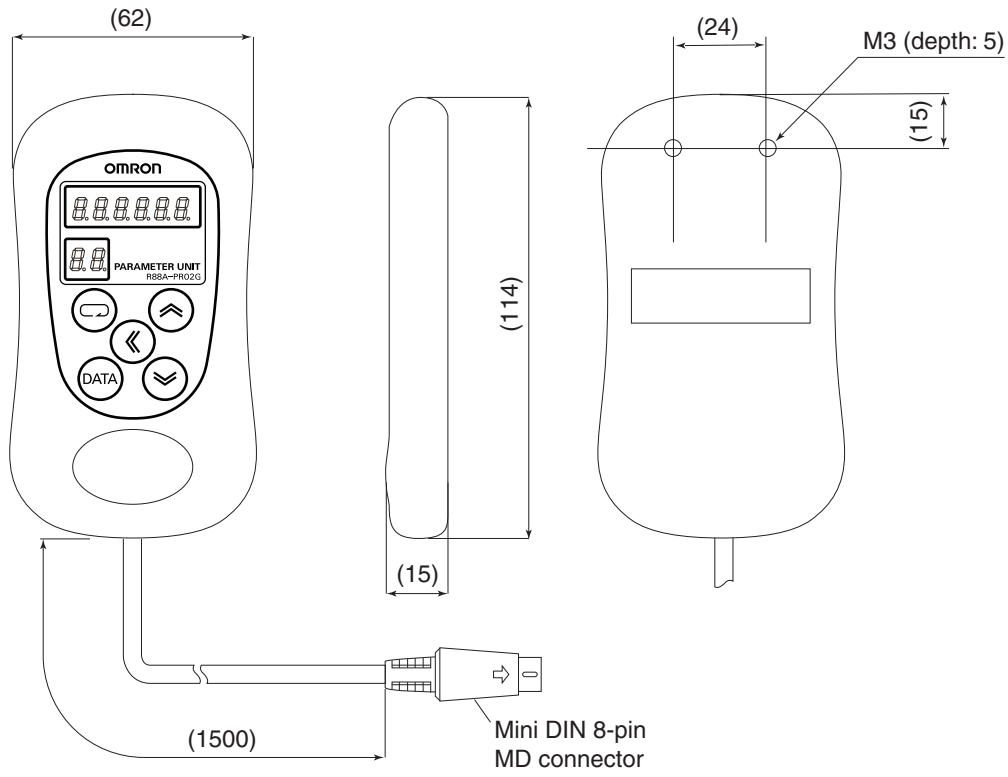



## Servomotor and Decelerator Combinations

### 3,000-r/min Servomotors

Motor model	1/5	1/11 (1/9 for flange size No.11)	1/21	1/33	1/45
R88M-G05030□	R88G-HPG11B05100B□ (Also used with R88M-G10030□)	R88G-HPG11B09050B□ (Gear ratio 1/9)	R88G-HPG14A21100B□ (Also used with R88M-G10030□)	R88G-HPG14A33050B□	R88G-HPG14A45050B□
R88M-G10030□	R88G-HPG11B05100B□	R88G-HPG14A11100B□	R88G-HPG14A21100B□	R88G-HPG20A33100B□	R88G-HPG20A45100B□
R88M-G20030□	R88G-HPG14A05200B□	R88G-HPG14A11200B□	R88G-HPG20A21200B□	R88G-HPG20A33200B□	R88G-HPG20A45200B□
R88M-G40030□	R88G-HPG14A05400B□	R88G-HPG20A11400B□	R88G-HPG20A21400B□	R88G-HPG32A33400B□	R88G-HPG32A45400B□
R88M-G75030□	R88G-HPG20A05750B□	R88G-HPG20A11750B□	R88G-HPG32A21750B□	R88G-HPG32A33750B□	R88G-HPG32A45750B□
R88M-G1K030T	R88G-HPG32A051K0B□	R88G-HPG32A111K0B□	R88G-HPG32A211K0B□	R88G-HPG32A331K0B□	R88G-HPG50A451K0B□
R88M-G1K530T	R88G-HPG32A052K0B□ (Also used with R88M-G2K030T)	R88G-HPG32A112K0B□ (Also used with R88M-G2K030T)	R88G-HPG32A211K5B□	R88G-HPG50A332K0B□ (Also used with R88M-G2K030T)	R88G-HPG50A451K5B□
R88M-G2K030T	R88G-HPG32A052K0B□	R88G-HPG32A112K0B□	R88G-HPG50A212K0B□	R88G-HPG50A332K0B□	---
R88M-G3K030T	R88G-HPG32A053K0B□	R88G-HPG50A113K0B□	R88G-HPG50A213K0B□	---	---
R88M-G4K030T	R88G-HPG32A054K0B□	R88G-HPG50A115K0B□ (Also used with R88M-G5K030T)	---	---	---
R88M-G5K030T	R88G-HPG50A055K0B□	R88G-HPG50A115K0B□	---	---	---

## 2-2 External and Mounting Hole Dimensions

### 3,000-r/min Flat Servomotors

Motor model	1/5	1/11	1/21	1/33	1/45
R88M-GP10030□	R88G-HPG11B05100PB□	R88G-HPG14A11100PB□	R88G-HPG14A21100PB□	R88G-HPG20A33100PB□	R88G-HPG20A45100PB□
R88M-GP20030□	R88G-HPG14A05200PB□	R88G-HPG20A11200PB□	R88G-HPG20A21200PB□	R88G-HPG20A33200PB□	R88G-HPG20A45200PB□
R88M-GP40030□	R88G-HPG20A05400PB□	R88G-HPG20A11400PB□	R88G-HPG20A21400PB□	R88G-HPG32A33400PB□	R88G-HPG32A45400PB□

### 2,000-r/min Servomotors

Motor model	1/5	1/11 (1/12 for flange size No.65)	1/21 (1/20 for flange size No.65)	1/33 (1/25 for flange size No.65)	1/45
R88M-G1K020T	R88G-HPG32A053K0B□ (Also used with R88M-G3K030T)	R88G-HPG32A112K0SB□ (Also used with R88M-G2K020T)	R88G-HPG32A211K0SB□	R88G-HPG50A332K0SB□ (Also used with R88M-G2K020T)	R88G-HPG50A451K0SB□
R88M-G1K520T	R88G-HPG32A053K0B□ (Also used with R88M-G3K030T)	R88G-HPG32A112K0SB□ (Also used with R88M-G2K020T)	R88G-HPG50A213K0B□ (Also used with R88M-G3K030T)	R88G-HPG50A332K0SB□ (Also used with R88M-G2K020T)	---
R88M-G2K020T	R88G-HPG32A053K0B□ (Also used with R88M-G3K030T)	R88G-HPG32A112K0SB□	R88G-HPG50A213K0B□ (Also used with R88M-G3K030T)	R88G-HPG50A332K0SB□	---
R88M-G3K020T	R88G-HPG32A054K0B□ (Also used with R88M-G4K030T)	R88G-HPG50A115K0B□ (Also used with R88M-G5K030T)	R88G-HPG50A213K0SB□	R88G-HPG65A253K0SB□	---
R88M-G4K020T	R88G-HPG50A054K0SB□	R88G-HPG50A114K0SB□	R88G-HPG65A204K0SB□	R88G-HPG65A254K0SB□	---
R88M-G5K020T	R88G-HPG50A055K0SB□	R88G-HPG50A115K0SB□	R88G-HPG65A205K0SB□	R88G-HPG65A255K0SB□	---
R88M-G7K515T	R88G-HPG65A057K5SB□	R88G-HPG65A127K5SB□	---	---	---

## 1,000-r/min Servomotors

Motor model	1/5	1/11 (1/12 for flange size No.65)	1/21 (1/20 for flange size No.65)	1/33 (1/25 for flange size No.65)
R88M- G90010T	R88G- HPG32A05900TB□	R88G- HPG32A11900TB□	R88G- HPG50A21900TB□	R88G- HPG50A33900TB□
R88M- G2K010T	R88G- HPG32A052K0TB□	R88G- HPG50A112K0TB□	R88G- HPG50A212K0TB□	R88G- HPG65A255K0SB□ (Also used with R88M- G5K020T)
R88M- G3K010T	R88G- HPG50A055K0SB□ (Also used with R88M- G5K020T)	R88G- HPG50A115K0SB□ (Also used with R88M- G5K020T)	R88G- HPG65A205K0SB□ (Also used with R88M- G5K020T)	R88G- HPG65A255K0SB□ (Also used with R88M- G5K020T)
R88M- G4K510T	R88G- HPG50A054K5TB□	R88G- HPG65A127K5SB□ (Also used with R88M- G7K515T)	R88G- HPG65A204K5TB□	---
R88M- G6K010T	R88G- HPG65A057K5SB□ (Also used with R88M- G7K515T)	R88G- HPG65A127K5SB□ (Also used with R88M- G7K515T)	---	---

## 2-2 External and Mounting Hole Dimensions

### Decelerator Dimensions

■ Backlash = 3' Max.

#### Decelerators for 3,000-r/min Servomotors

Model			Dimensions (mm)												
			LM	LR	C1	C2	D1	D2	D3	D4	D5	E	F1	F2	G
50 W	1/5	R88G-HPG11B05100B□	39.5	42	40	40×40	46	46	40.0	39.5	29	27	2.2	15	5
	1/9	R88G-HPG11B09050B□	39.5	42	40	40×40	46	46	40.0	39.5	29	27	2.2	15	5
	1/21	R88G-HPG14A21100B□	64.0	58	60	60×60	70	46	56.0	55.5	40	37	2.5	21	8
	1/33	R88G-HPG14A33050B□	64.0	58	60	60×60	70	46	56.0	55.5	40	37	2.5	21	8
	1/45	R88G-HPG14A45050B□	64.0	58	60	60×60	70	46	56.0	55.5	40	37	2.5	21	8
100 W	1/5	R88G-HPG11B05100B□	39.5	42	40	40×40	46	46	40.0	39.5	29	27	2.2	15	5
	1/11	R88G-HPG14A11100B□	64.0	58	60	60×60	70	46	56.0	55.5	40	37	2.5	21	8
	1/21	R88G-HPG14A21100B□	64.0	58	60	60×60	70	46	56.0	55.5	40	37	2.5	21	8
	1/33	R88G-HPG20A33100B□	66.5	80	90	55 dia.	105	46	85.0	84.0	59	53	7.5	27	10
	1/45	R88G-HPG20A45100B□	66.5	80	90	55 dia.	105	46	85.0	84.0	59	53	7.5	27	10
200 W	1/5	R88G-HPG14A05200B□	64.0	58	60	60×60	70	70	56.0	55.5	40	37	2.5	21	8
	1/11	R88G-HPG14A11200B□	64.0	58	60	60×60	70	70	56.0	55.5	40	37	2.5	21	8
	1/21	R88G-HPG20A21200B□	71.0	80	90	89 dia.	105	70	85.0	84.0	59	53	7.5	27	10
	1/33	R88G-HPG20A33200B□	71.0	80	90	89 dia.	105	70	85.0	84.0	59	53	7.5	27	10
	1/45	R88G-HPG20A45200B□	71.0	80	90	89 dia.	105	70	85.0	84.0	59	53	7.5	27	10

Model			Dimensions (mm)										
			S	T	Z1	Z2	AT <sup>*1</sup>	Key dimensions				Tap dimensions	
								QK	b	h	t1	M	L
50 W	1/5	R88G-HPG11B05100B□	8	20	3.4	M4×9	M3	15	3	3	1.8	M3	6
	1/9	R88G-HPG11B09050B□	8	20	3.4	M4×9	M3	15	3	3	1.8	M3	6
	1/21	R88G-HPG14A21100B□	16	28	5.5	M4×10	M3	25	5	5	3	M4	8
	1/33	R88G-HPG14A33050B□	16	28	5.5	M4×10	M3	25	5	5	3	M4	8
	1/45	R88G-HPG14A45050B□	16	28	5.5	M4×10	M3	25	5	5	3	M4	8
100 W	1/5	R88G-HPG11B05100B□	8	20	3.4	M4×9	M3	15	3	3	1.8	M3	6
	1/11	R88G-HPG14A11100B□	16	28	5.5	M4×10	M3	25	5	5	3	M4	8
	1/21	R88G-HPG14A21100B□	16	28	5.5	M4×10	M3	25	5	5	3	M4	8
	1/33	R88G-HPG20A33100B□	25	42	9.0	M4×10	M4	36	8	7	4.0	M6	12
	1/45	R88G-HPG20A45100B□	25	42	9.0	M4×10	M4	36	8	7	4.0	M6	12
200 W	1/5	R88G-HPG14A05200B□	16	28	5.5	M4×10	M4	25	5	5	3	M4	8
	1/11	R88G-HPG14A11200B□	16	28	5.5	M4×10	M4	25	5	5	3	M4	8
	1/21	R88G-HPG20A21200B□	25	42	9.0	M4×10	M4	36	8	7	4.0	M6	12
	1/33	R88G-HPG20A33200B□	25	42	9.0	M4×10	M4	36	8	7	4.0	M6	12
	1/45	R88G-HPG20A45200B□	25	42	9.0	M4×10	M4	36	8	7	4.0	M6	12

**Note 1.** The standard models have a straight shaft.

**Note 2.** Models with a key and tap are indicated with "J" at the end of the model number (the suffix shown in the box). (Example: R88G-HPG11B05100BJ)

**Note 3.** The diameter of the motor shaft insertion hole is the same as the shaft diameter of the corresponding motors.

Model			Dimensions (mm)												
			LM	LR	C1	C2	D1	D2	D3	D4	D5	E	F1	F2	G
400 W	1/5	R88G-HPG14A05400B□	64.0	58	60	60×60	70	70	56.0	55.5	40	37	2.5	21	8
	1/11	R88G-HPG20A11400B□	71.0	80	90	89 dia.	105	70	85.0	84.0	59	53	7.5	27	10
	1/21	R88G-HPG20A21400B□	71.0	80	90	89 dia.	105	70	85.0	84.0	59	53	7.5	27	10
	1/33	R88G-HPG32A33400B□	104.0	133	120	122 dia.	135	70	115.0	114.0	84	98	12.5	35	13
	1/45	R88G-HPG32A45400B□	104.0	133	120	122 dia.	135	70	115.0	114.0	84	98	12.5	35	13
750 W	1/5	R88G-HPG20A05750B□	78.0	80	90	80×80	105	90	85.0	84.0	59	53	7.5	27	10
	1/11	R88G-HPG20A11750B□	78.0	80	90	80×80	105	90	85.0	84.0	59	53	7.5	27	10
	1/21	R88G-HPG32A21750B□	104.0	133	120	122 dia.	135	90	115.0	114.0	84	98	12.5	35	13
	1/33	R88G-HPG32A33750B□	104.0	133	120	122 dia.	135	90	115.0	114.0	84	98	12.5	35	13
	1/45	R88G-HPG32A45750B□	104.0	133	120	122 dia.	135	90	115.0	114.0	84	98	12.5	35	13

Model			Dimensions (mm)										
			S	T	Z1	Z2	AT*1	Key dimensions				Tap dimensions	
								QK	b	h	t1	M	L
400 W	1/5	R88G-HPG14A05400B□	16	28	5.5	M4×10	M4	25	5	5	3	M4	8
	1/11	R88G-HPG20A11400B□	25	42	9.0	M4×10	M4	36	8	7	4.0	M6	12
	1/21	R88G-HPG20A21400B□	25	42	9.0	M4×10	M4	36	8	7	4.0	M6	12
	1/33	R88G-HPG32A33400B□	40	82	11.0	M4×10	M4	70	12	8	5.0	M10	20
	1/45	R88G-HPG32A45400B□	40	82	11.0	M4×10	M4	70	12	8	5.0	M10	20
750 W	1/5	R88G-HPG20A05750B□	25	42	9.0	M5×12	M4	36	8	7	4.0	M6	12
	1/11	R88G-HPG20A11750B□	25	42	9.0	M5×12	M4	36	8	7	4.0	M6	12
	1/21	R88G-HPG32A21750B□	40	82	11.0	M5×12	M6	70	12	8	5.0	M10	20
	1/33	R88G-HPG32A33750B□	40	82	11.0	M5×12	M6	70	12	8	5.0	M10	20
	1/45	R88G-HPG32A45750B□	40	82	11.0	M5×12	M6	70	12	8	5.0	M10	20

\*1. This is the set bolt.

Outline Drawings

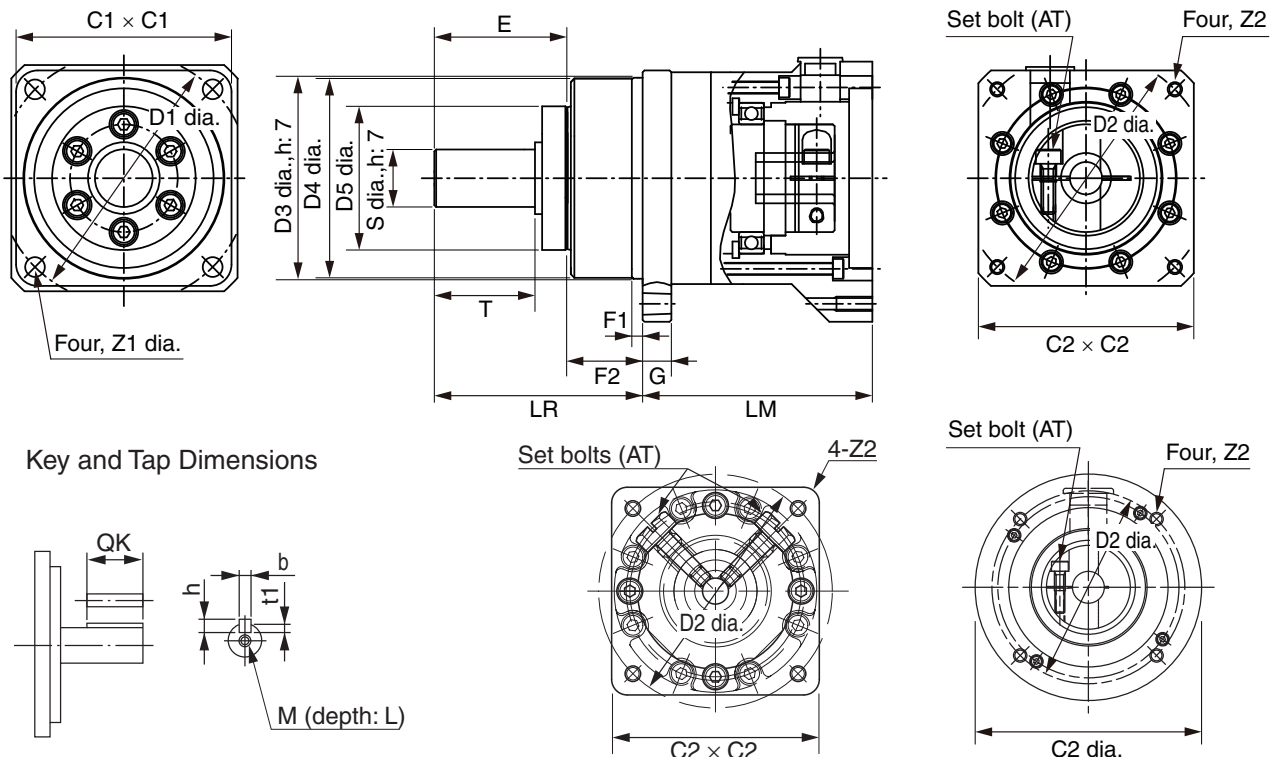

For the R88G-HPG11B Series, two set bolts are positioned at 90° from each other.

## 2-2 External and Mounting Hole Dimensions

Model			Dimensions (mm)											
			LM	LR	C1	C2	D1	D2	D3	D4	D5	E	F1	F2
1 kW	1/5	R88G-HPG32A051K0B□	104	133	120	122 dia.	135	100	115	114	84	98	12.5	35
	1/11	R88G-HPG32A111K0B□	104	133	120	122 dia.	135	100	115	114	84	98	12.5	35
	1/21	R88G-HPG32A211K0B□	104	133	120	122 dia.	135	100	115	114	84	98	12.5	35
	1/33	R88G-HPG32A331K0B□	104	133	120	122 dia.	135	100	115	114	84	98	12.5	35
	1/45	R88G-HPG50A451K0B□	123	156	170	170 dia.	190	100	165	163	122	103	12.0	53
1.5 kW	1/5	R88G-HPG32A052K0B□	110	133	120	135 dia.	135	115	115	114	84	98	12.5	35
	1/11	R88G-HPG32A112K0B□	110	133	120	135 dia.	135	115	115	114	84	98	12.5	35
	1/21	R88G-HPG32A211K5B□	110	133	120	135 dia.	135	115	115	114	84	98	12.5	35
	1/33	R88G-HPG50A332K0B□	123	156	170	170 dia.	190	115	165	163	122	103	12.0	53
	1/45	R88G-HPG50A451K5B□	123	156	170	170 dia.	190	115	165	163	122	103	12.0	53
2 kW	1/5	R88G-HPG32A052K0B□	110	133	120	135 dia.	135	115	115	114	84	98	12.5	35
	1/11	R88G-HPG32A112K0B□	110	133	120	135 dia.	135	115	115	114	84	98	12.5	35
	1/21	R88G-HPG50A212K0B□	123	156	170	170 dia.	190	115	165	163	122	103	12.0	53
	1/33	R88G-HPG50A332K0B□	123	156	170	170 dia.	190	115	165	163	122	103	12.0	53
3 kW	1/5	R88G-HPG32A053K0B□	107	133	120	130×130	135	145	115	114	84	98	12.5	35
	1/11	R88G-HPG50A113K0B□	123	156	170	170 dia.	190	145	165	163	122	103	12.0	53
	1/21	R88G-HPG50A213K0B□	123	156	170	170 dia.	190	145	165	163	122	103	12.0	53
4 kW	1/5	R88G-HPG32A054K0B□	129	133	120	130×130	135	145	115	114	84	98	12.5	35
	1/11	R88G-HPG50A115K0B□	149	156	170	130×130	190	145	165	163	122	103	12.0	53
5 kW	1/5	R88G-HPG50A055K0B□	149	156	170	130×130	190	145	165	163	122	103	12.0	53
	1/11	R88G-HPG50A115K0B□	149	156	170	130×130	190	145	165	163	122	103	12.0	53

**Note 1.** The standard models have a straight shaft.

**Note 2.** Models with a key and tap are indicated with “J” at the end of the model number (the suffix shown in the box). (Example: R88G-HPG32A051K0BJ)

**Note 3.** The diameter of the motor shaft insertion hole is the same as the shaft diameter of the corresponding motors.

Model			Dimensions (mm)											
			G	S	T	Z1	Z2	AT*1	Key dimensions				Tap dimensions	
									QK	b	h	t1	M	L
1 kW	1/5	R88G-HPG32A051K0B□	13	40	82	11	M6×12	M6	70	12	8	5.0	M10	20
	1/11	R88G-HPG32A111K0B□	13	40	82	11	M6×12	M6	70	12	8	5.0	M10	20
	1/21	R88G-HPG32A211K0B□	13	40	82	11	M6×12	M6	70	12	8	5.0	M10	20
	1/33	R88G-HPG32A331K0B□	13	40	82	11	M6×12	M6	70	12	8	5.0	M10	20
	1/45	R88G-HPG50A451K0B□	16	50	82	14	M6×10	M6	70	14	9	5.5	M10	20
1.5 kW	1/5	R88G-HPG32A052K0B□	13	40	82	11	M8×10	M6	70	12	8	5.0	M10	20
	1/11	R88G-HPG32A112K0B□	13	40	82	11	M8×10	M6	70	12	8	5.0	M10	20
	1/21	R88G-HPG32A211K5B□	13	40	82	11	M8×10	M6	70	12	8	5.0	M10	20
	1/33	R88G-HPG50A332K0B□	16	50	82	14	M8×10	M6	70	14	9	5.5	M10	20
	1/45	R88G-HPG50A451K5B□	16	50	82	14	M8×10	M6	70	14	9	5.5	M10	20
2 kW	1/5	R88G-HPG32A052K0B□	13	40	82	11	M8×10	M6	70	12	8	5.0	M10	20
	1/11	R88G-HPG32A112K0B□	13	40	82	11	M8×10	M6	70	12	8	5.0	M10	20
	1/21	R88G-HPG50A212K0B□	16	50	82	14	M8×10	M6	70	14	9	5.5	M10	20
	1/33	R88G-HPG50A332K0B□	16	50	82	14	M8×10	M6	70	14	9	5.5	M10	20
3 kW	1/5	R88G-HPG32A053K0B□	13	40	82	11	M8×18	M6	70	12	8	5.0	M10	20
	1/11	R88G-HPG50A113K0B□	16	50	82	14	M8×16	M6	70	14	9	5.5	M10	20
	1/21	R88G-HPG50A213K0B□	16	50	82	14	M8×16	M6	70	14	9	5.5	M10	20
4 kW	1/5	R88G-HPG32A054K0B□	13	40	82	11	M8×25	M6	70	12	8	5.0	M10	20
	1/11	R88G-HPG50A115K0B□	16	50	82	14	M8×25	M6	70	14	9	5.5	M10	20
5 kW	1/5	R88G-HPG50A055K0B□	16	50	82	14	M8×25	M6	70	14	9	5.5	M10	20
	1/11	R88G-HPG50A115K0B□	16	50	82	14	M8×25	M6	70	14	9	5.5	M10	20

\*1. This is the set bolt.

Outline Drawings

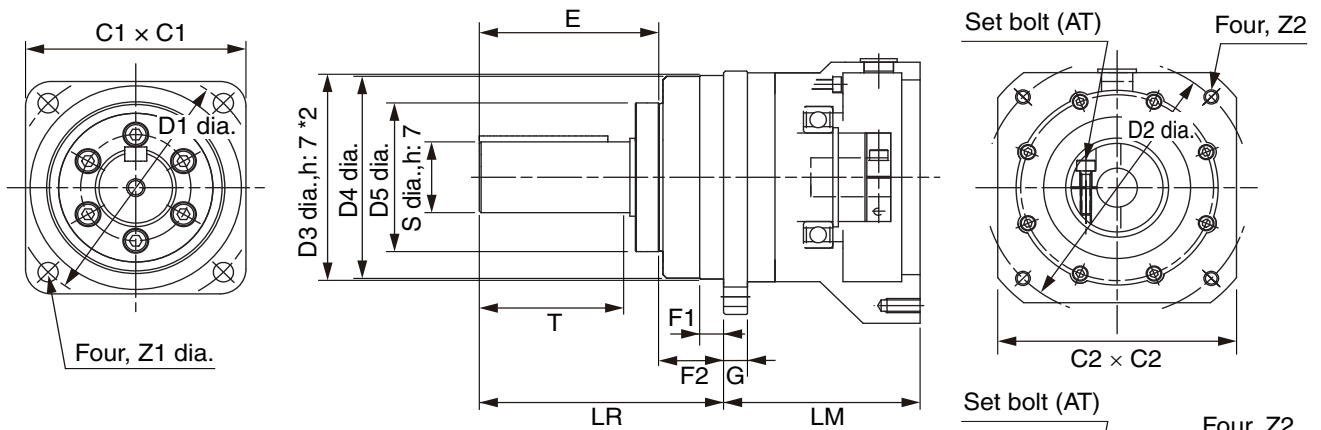

Key and Tap Dimensions

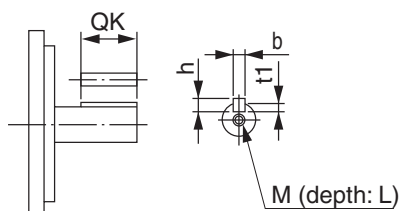

\*2. With the R88G-HPG50□, the height tolerance is 8 mm (D3 dia., h: 8).

## 2-2 External and Mounting Hole Dimensions

### Decelerators for 2,000-r/min Servomotors

Model			Dimensions (mm)											
			LM	LR	C1	C2	D1	D2	D3	D4	D5	E	F1	F2
1 kW	1/5	R88G-HPG32A053K0B□	107	133	120	130×130	135	145	115	114	84	98	12.5	35
	1/11	R88G-HPG32A112K0SB□	107	133	120	130×130	135	145	115	114	84	98	12.5	35
	1/21	R88G-HPG32A211K0SB□	107	133	120	130×130	135	145	115	114	84	98	12.5	35
	1/33	R88G-HPG50A332K0SB□	123	156	170	170 dia.	190	145	165	163	122	103	12.0	53
	1/45	R88G-HPG50A451K0SB□	123	156	170	170 dia.	190	145	165	163	122	103	12.0	53
1.5 kW	1/5	R88G-HPG32A053K0B□	107	133	120	130×130	135	145	115	114	84	98	12.5	35
	1/11	R88G-HPG32A112K0SB□	107	133	120	130×130	135	145	115	114	84	98	12.5	35
	1/21	R88G-HPG50A213K0B□	123	156	170	170 dia.	190	145	165	163	122	103	12.0	53
	1/33	R88G-HPG50A332K0SB□	123	156	170	170 dia.	190	145	165	163	122	103	12.0	53
2 kW	1/5	R88G-HPG32A053K0B□	107	133	120	130×130	135	145	115	114	84	98	12.5	35
	1/11	R88G-HPG32A112K0SB□	107	133	120	130×130	135	145	115	114	84	98	12.5	35
	1/21	R88G-HPG50A213K0B□	123	156	170	170 dia.	190	145	165	163	122	103	12.0	53
	1/33	R88G-HPG50A332K0SB□	123	156	170	170 dia.	190	145	165	163	122	103	12.0	53
3 kW	1/5	R88G-HPG32A054K0B□	129	133	120	130×130	135	145	115	114	84	98	12.5	35
	1/11	R88G-HPG50A115K0B□	149	156	170	130×130	190	145	165	163	122	103	12.0	53
	1/21	R88G-HPG50A213K0SB□	149	156	170	130×130	190	145	165	163	122	103	12.0	53
	1/25	R88G-HPG65A253K0SB□	231	222	230	130×130	260	145	220	214	168	165	12.0	57

Model			Dimensions (mm)											
			G	S	T	Z1	Z2	AT <sup>1</sup>	Key dimensions				Tap dimensions	
									QK	b	h	t1	M	L
1 kW	1/5	R88G-HPG32A053K0B□	13	40	82	11	M8×18	M6	70	12	8	5.0	M10	20
	1/11	R88G-HPG32A112K0SB□	13	40	82	11	M8×18	M6	70	12	8	5.0	M10	20
	1/21	R88G-HPG32A211K0SB□	13	40	82	11	M8×18	M6	70	12	8	5.0	M10	20
	1/33	R88G-HPG50A332K0SB□	16	50	82	14	M8×16	M6	70	14	9	5.5	M10	20
	1/45	R88G-HPG50A451K0SB□	16	50	82	14	M8×16	M6	70	14	9	5.5	M10	20
1.5 kW	1/5	R88G-HPG32A053K0B□	13	40	82	11	M8×18	M6	70	12	8	5.0	M10	20
	1/11	R88G-HPG32A112K0SB□	13	40	82	11	M8×18	M6	70	12	8	5.0	M10	20
	1/21	R88G-HPG50A213K0B□	16	50	82	14	M8×16	M6	70	14	9	5.5	M10	20
	1/33	R88G-HPG50A332K0SB□	16	50	82	14	M8×16	M6	70	14	9	5.5	M10	20
2 kW	1/5	R88G-HPG32A053K0B□	13	40	82	11	M8×18	M6	70	12	8	5.0	M10	20
	1/11	R88G-HPG32A112K0SB□	13	40	82	11	M8×18	M6	70	12	8	5.0	M10	20
	1/21	R88G-HPG50A213K0B□	16	50	82	14	M8×16	M6	70	14	9	5.5	M10	20
	1/33	R88G-HPG50A332K0SB□	16	50	82	14	M8×16	M6	70	14	9	5.5	M10	20
3 kW	1/5	R88G-HPG32A054K0B□	13	40	82	11	M8×25	M6	70	12	8	5.0	M10	20
	1/11	R88G-HPG50A115K0B□	16	50	82	14	M8×25	M6	70	14	9	5.5	M10	20
	1/21	R88G-HPG50A213K0SB□	16	50	82	14	M8×25	M6	70	14	9	5.5	M10	20
	1/25	R88G-HPG65A253K0SB□	25	80	130	18	M8×25	M8	110	22	14	9.0	M16	35

**Note 1.** The standard models have a straight shaft.

**Note 2.** Models with a key and tap are indicated with "J" at the end of the model number (the suffix shown in the box). (Example: R88G-HPG32A053K0BJ)

**Note 3.** The diameter of the motor shaft insertion hole is the same as the shaft diameter of the corresponding motors.



Model			Dimensions (mm)											
			LM	LR	C1	C2	D1	D2	D3	D4	D5	E	F1	F2
4 kW	1/5	R88G-HPG50A054K0SB□	149	156	170	180×180	190	165	165	163	122	103	12.0	53
	1/11	R88G-HPG50A114K0SB□	149	156	170	180×180	190	165	165	163	122	103	12.0	53
	1/20	R88G-HPG65A204K0SB□	231	222	230	180×180	260	165	220	214	168	165	12.0	57
	1/25	R88G-HPG65A254K0SB□	231	222	230	180×180	260	165	220	214	168	165	12.0	57
5 kW	1/5	R88G-HPG50A055K0SB□	149	156	170	180×180	190	200	165	163	122	103	12.0	53
	1/11	R88G-HPG50A115K0SB□	149	156	170	180×180	190	200	165	163	122	103	12.0	53
	1/20	R88G-HPG65A205K0SB□	231	222	230	180×180	260	200	220	214	168	165	12.0	57
	1/25	R88G-HPG65A255K0SB□	231	222	230	180×180	260	200	220	214	168	165	12.0	57
7.5 kW	1/5	R88G-HPG65A057K5SB□	184.5	222	230	180×180	260	200	220	214	168	165	12.0	57
	1/12	R88G-HPG65A127K5SB□	254.5	222	230	180×180	260	200	220	214	168	165	12.0	57

Model			Dimensions (mm)										Tap dimensions	
			G	S	T	Z1	Z2	AT*1	Key dimensions				M	L
									QK	b	h	t1		
4 kW	1/5	R88G-HPG50A054K0SB□	16	50	82	14	M10×25	M6	70	14	9	5.5	M10	20
	1/11	R88G-HPG50A114K0SB□	16	50	82	14	M10×25	M6	70	14	9	5.5	M10	20
	1/20	R88G-HPG65A204K0SB□	25	80	130	18	M10×25	M8	110	22	14	9.0	M16	35
	1/25	R88G-HPG65A254K0SB□	25	80	130	18	M10×25	M8	110	22	14	9.0	M16	35
5 kW	1/5	R88G-HPG50A055K0SB□	16	50	82	14	M12×25	M6	70	14	9	5.5	M10	20
	1/11	R88G-HPG50A115K0SB□	16	50	82	14	M12×25	M6	70	14	9	5.5	M10	20
	1/20	R88G-HPG65A205K0SB□	25	80	130	18	M12×25	M8	110	22	14	9.0	M16	35
	1/25	R88G-HPG65A255K0SB□	25	80	130	18	M12×25	M8	110	22	14	9.0	M16	35
7.5 kW	1/5	R88G-HPG65A057K5SB□	25	80	130	18	M12×25	M8	110	22	14	9.0	M16	35
	1/12	R88G-HPG65A127K5SB□	25	80	130	18	M12×25	M8	110	22	14	9.0	M16	35

\*1. This is the set bolt.

Outline Drawings

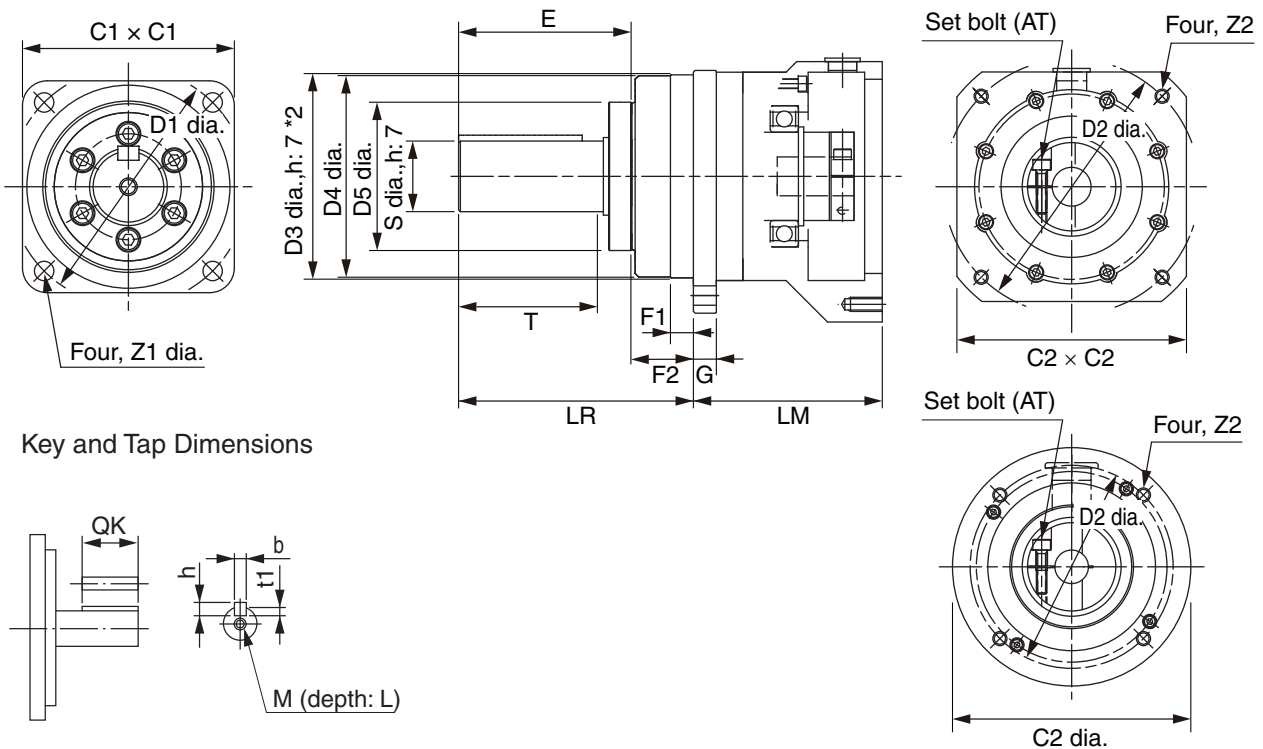

\*2. With the R88G-HPG50□/-HPG65□, the height tolerance is 8 mm (D3 dia., h: 8).

## 2-2 External and Mounting Hole Dimensions

### Decelerators for 1,000-r/min Servomotors

Model			Dimensions (mm)											
			LM	LR	C1	C2	D1	D2	D3	D4	D5	E	F1	F2
900 W	1/5	R88G-HPG32A05900TB□	129	133	120	130×130	135	145	115	114	84	98	12.5	35
	1/11	R88G-HPG32A11900TB□	129	133	120	130×130	135	145	115	114	84	98	12.5	35
	1/21	R88G-HPG50A21900TB□	149	156	170	130×130	190	145	165	163	122	103	12.0	53
	1/33	R88G-HPG50A33900TB□	149	156	170	130×130	190	145	165	163	122	103	12.0	53
2 kW	1/5	R88G-HPG32A052K0TB□	129	133	120	180×180	135	200	115	114	84	98	12.5	35
	1/11	R88G-HPG50A112K0TB□	149	156	170	180×180	190	200	165	163	122	103	12.0	53
	1/21	R88G-HPG50A212K0TB□	149	156	170	180×180	190	200	165	163	122	103	12.0	53
	1/25	R88G-HPG65A255K0SB□	231	222	230	180×180	260	200	220	214	168	165	12.0	57
3 kW	1/5	R88G-HPG50A055K0SB□	149	156	170	180×180	190	200	165	163	122	103	12.0	53
	1/11	R88G-HPG50A115K0SB□	149	156	170	180×180	190	200	165	163	122	103	12.0	53
	1/20	R88G-HPG65A205K0SB□	231	222	230	180×180	260	200	220	214	168	165	12.0	57
	1/25	R88G-HPG65A255K0SB□	231	222	230	180×180	260	200	220	214	168	165	12.0	57
4.5 kW	1/5	R88G-HPG50A054K5TB□	149	156	170	180×180	190	200	165	163	122	103	12.0	53
	1/12	R88G-HPG65A127K5SB□	254.5	222	230	180×180	260	200	220	214	168	165	12.0	57
	1/20	R88G-HPG65A204K5TB□	254.5	222	230	180×180	260	200	220	214	168	165	12.0	57
6 kW	1/5	R88G-HPG65A057K5SB□	184.5	222	230	180×180	260	200	220	214	168	165	12.0	57
	1/12	R88G-HPG65A127K5SB□	254.5	222	230	180×180	260	200	220	214	168	165	12.0	57

**Note 1.** The standard models have a straight shaft.

**Note 2.** Models with a key and tap are indicated with “J” at the end of the model number (the suffix shown in the box). (Example: R88G-HPG32A05900TBJ)

**Note 3.** The diameter of the motor shaft insertion hole is the same as the shaft diameter of the corresponding motors.

Model			Dimensions (mm)											
			G	S	T	Z1	Z2	AT <sup>*1</sup>	Key dimensions				Tap dimensions	
									QK	b	h	t1	M	L
900 W	1/5	R88G-HPG32A05900TB□	13	40	82	11	M8×25	M6	70	12	8	5.0	M10	20
	1/11	R88G-HPG32A11900TB□	13	40	82	11	M8×25	M6	70	12	8	5.0	M10	20
	1/21	R88G-HPG50A21900TB□	16	50	82	14	M8×25	M6	70	14	9	5.5	M10	20
	1/33	R88G-HPG50A33900TB□	16	50	82	14	M8×25	M6	70	14	9	5.5	M10	20
2 kW	1/5	R88G-HPG32A052K0TB□	13	40	82	11	M12×25	M6	70	12	8	5.0	M10	20
	1/11	R88G-HPG50A112K0TB□	16	50	82	14	M12×25	M6	70	14	9	5.5	M10	20
	1/21	R88G-HPG50A212K0TB□	16	50	82	14	M12×25	M6	70	14	9	5.5	M10	20
	1/25	R88G-HPG65A255K0SB□	25	80	130	18	M12×25	M8	110	22	14	9.0	M16	35
3 kW	1/5	R88G-HPG50A055K0SB□	16	50	82	14	M12×25	M6	70	14	9	5.5	M10	20
	1/11	R88G-HPG50A115K0SB□	16	50	82	14	M12×25	M6	70	14	9	5.5	M10	20
	1/20	R88G-HPG65A205K0SB□	25	80	130	18	M12×25	M8	110	22	14	9.0	M16	35
	1/25	R88G-HPG65A255K0SB□	25	80	130	18	M12×25	M8	110	22	14	9.0	M16	35
4.5 kW	1/5	R88G-HPG50A054K5TB□	16	50	82	14	M12×25	M6	70	14	9	5.5	M10	20
	1/12	R88G-HPG65A127K5SB□	25	80	130	18	M12×25	M8	110	22	14	9.0	M16	35
	1/20	R88G-HPG65A204K5TB□	25	80	130	18	M12×25	M8	110	22	14	9.0	M16	35
6 kW	1/5	R88G-HPG65A057K5SB□	25	80	130	18	M12×25	M8	110	22	14	9.0	M16	35
	1/12	R88G-HPG65A127K5SB□	25	80	130	18	M12×25	M8	110	22	14	9.0	M16	35

\*1. This is the set bolt.

Outline Drawings

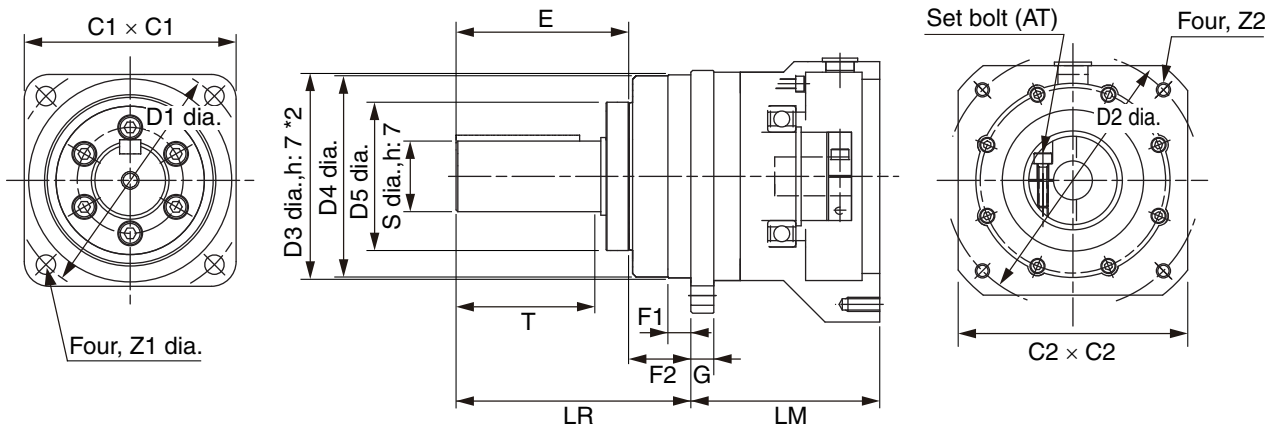

Key and Tap Dimensions

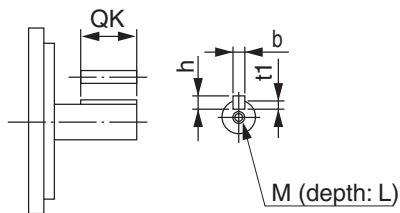

\*2. With the R88G-HPG50□/-HPG65□, the height tolerance is 8 mm (D3 dia., h: 8).

## 2-2 External and Mounting Hole Dimensions

### Decelerators for 3,000-r/min Flat Servomotors

Model			Dimensions (mm)											
			LM	LR	C1	C2	D1	D2	D3	D4	D5	E	F1	F2
100 W	1/5	R88G-HPG11B05100PB□	39.5	42	40	60×60	46	70	40.0	39.5	29	27	2.2	15
	1/11	R88G-HPG14A11100PB□	64.0	58	60	60×60	70	70	56.0	55.5	40	37	2.5	21
	1/21	R88G-HPG14A21100PB□	64.0	58	60	60×60	70	70	56.0	55.5	40	37	2.5	21
	1/33	R88G-HPG20A33100PB□	71.0	80	90	89 dia.	105	70	85.0	84.0	59	53	7.5	27
	1/45	R88G-HPG20A45100PB□	71.0	80	90	89 dia.	105	70	85.0	84.0	59	53	7.5	27

Model			Dimensions (mm)											
			G	S	T	Z1	Z2	AT <sup>*1</sup>	Key dimensions				Tap dimensions	
									QK	b	h	t1	M	L
100 W	1/5	R88G-HPG11B05100PB□	5	8	20	3.4	M4×9	M3	15	3	3	1.8	M3	6
	1/11	R88G-HPG14A11100PB□	8	16	28	5.5	M4×10	M3	25	5	5	3.0	M4	8
	1/21	R88G-HPG14A21100PB□	8	16	28	5.5	M4×10	M3	25	5	5	3.0	M4	8
	1/33	R88G-HPG20A33100PB□	10	25	42	9.0	M4×10	M3	36	8	7	4.0	M6	12
	1/45	R88G-HPG20A45100PB□	10	25	42	9.0	M4×10	M3	36	8	7	4.0	M6	12

Model			Dimensions (mm)											
			LM	LR	C1	C2	D1	D2	D3	D4	D5	E	F1	F2
200 W	1/5	R88G-HPG14A05200PB□	65.0	58	60	80×80	70	90	56.0	55.5	40	37	2.5	21
	1/11	R88G-HPG20A11200PB□	78.0	80	90	80×80	105	90	85.0	84.0	59	53	7.5	27
	1/21	R88G-HPG20A21200PB□	78.0	80	90	80×80	105	90	85.0	84.0	59	53	7.5	27
	1/33	R88G-HPG20A33200PB□	78.0	80	90	80×80	105	90	85.0	84.0	59	53	7.5	27
	1/45	R88G-HPG20A45200PB□	78.0	80	90	80×80	105	90	85.0	84.0	59	53	7.5	27

Model			Dimensions (mm)											
			G	S	T	Z1	Z2	AT <sup>*1</sup>	Key dimensions				Tap dimensions	
									QK	b	h	t1	M	L
200 W	1/5	R88G-HPG14A05200PB□	8	16	28	5.5	M5×12	M4	25	5	5	3.0	M4	8
	1/11	R88G-HPG20A11200PB□	10	25	42	9.0	M5×12	M4	36	8	7	4.0	M6	12
	1/21	R88G-HPG20A21200PB□	10	25	42	9.0	M5×12	M4	36	8	7	4.0	M6	12
	1/33	R88G-HPG20A33200PB□	10	25	42	9.0	M5×12	M4	36	8	7	4.0	M6	12
	1/45	R88G-HPG20A45200PB□	10	25	42	9.0	M5×12	M4	36	8	7	4.0	M6	12

**Note 1.** The standard models have a straight shaft.

**Note 2.** Models with a key and tap are indicated with "J" at the end of the model number (the suffix shown in the box). (Example: R88G-HPG11B05100PB<sup>J</sup>)

**Note 3.** The diameter of the motor shaft insertion hole is the same as the shaft diameter of the corresponding motors.

Model			Dimensions (mm)											
			LM	LR	C1	C2	D1	D2	D3	D4	D5	E	F1	F2
400 W	1/5	R88G-HPG20A05400PB□	78.0	80	90	80×80	105	90	85.0	84.0	59	53	7.5	27
	1/11	R88G-HPG20A11400PB□	78.0	80	90	80×80	105	90	85.0	84.0	59	53	7.5	27
	1/21	R88G-HPG20A21400PB□	78.0	80	90	80×80	105	90	85.0	84.0	59	53	7.5	27
	1/33	R88G-HPG32A33400PB□	104.0	133	120	122 dia.	135	90	115.0	114.0	84	98	12.5	35
	1/45	R88G-HPG32A45400PB□	104.0	133	120	122 dia.	135	90	115.0	114.0	84	98	12.5	35

Model			Dimensions (mm)											
			G	S	T	Z1	Z2	AT*1	Key dimensions				Tap dimensions	
									QK	b	h	t1	M	L
400 W	1/5	R88G-HPG20A05400PB□	10	25	42	9.0	M5×12	M4	36	8	7	4.0	M6	12
	1/11	R88G-HPG20A11400PB□	10	25	42	9.0	M5×12	M4	36	8	7	4.0	M6	12
	1/21	R88G-HPG20A21400PB□	10	25	42	9.0	M5×12	M4	36	8	7	4.0	M6	12
	1/33	R88G-HPG32A33400PB□	13	40	82	11.0	M5×12	M6	70	12	8	5.0	M10	20
	1/45	R88G-HPG32A45400PB□	13	40	82	11.0	M5×12	M6	70	12	8	5.0	M10	20

\*1 This is the set bolt.

Outline Drawings

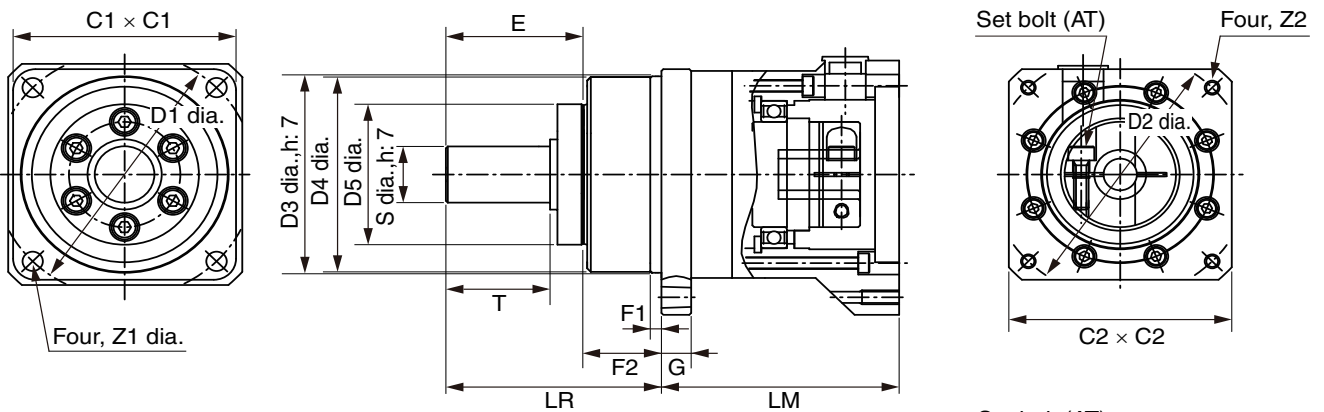

Key and Tap Dimensions



## 2-2 External and Mounting Hole Dimensions

■ Backlash = 15' Max.

### Decelerators for 3,000-r/min Servomotors

Model			Dimensions (mm)										
			LM	LR	C1	C2	D1	D2	D3	D4	E3	F	G
50 W	1/5	R88G-VRSF05B100CJ	67.5	32	40	52	46	60	50	45	10	3	6
	1/9	R88G-VRSF09B100CJ	67.5	32	40	52	46	60	50	45	10	3	6
	1/15	R88G-VRSF15B100CJ	78.0	32	40	52	46	60	50	45	10	3	6
	1/25	R88G-VRSF25B100CJ	78.0	32	40	52	46	60	50	45	10	3	6
100 W	1/5	R88G-VRSF05B100CJ	67.5	32	40	52	46	60	50	45	10	3	6
	1/9	R88G-VRSF09B100CJ	67.5	32	40	52	46	60	50	45	10	3	6
	1/15	R88G-VRSF15B100CJ	78.0	32	40	52	46	60	50	45	10	3	6
	1/25	R88G-VRSF25B100CJ	78.0	32	40	52	46	60	50	45	10	3	6
200 W	1/5	R88G-VRSF05B200CJ	72.5	32	60	52	70	60	50	45	10	3	10
	1/9	R88G-VRSF09C200CJ	89.5	50	60	78	70	90	70	62	17	3	8
	1/15	R88G-VRSF15C200CJ	100.0	50	60	78	70	90	70	62	17	3	8
	1/25	R88G-VRSF25C200CJ	100.0	50	60	78	70	90	70	62	17	3	8
400 W	1/5	R88G-VRSF05C400CJ	89.5	50	60	78	70	90	70	62	17	3	8
	1/9	R88G-VRSF09C400CJ	89.5	50	60	78	70	90	70	62	17	3	8
	1/15	R88G-VRSF15C400CJ	100.0	50	60	78	70	90	70	62	17	3	8
	1/25	R88G-VRSF25C400CJ	100.0	50	60	78	70	90	70	62	17	3	8
750 W	1/5	R88G-VRSF05C750CJ	93.5	50	80	78	90	90	70	62	17	3	10
	1/9	R88G-VRSF09D750CJ	97.5	61	80	98	90	115	90	75	18	5	10
	1/15	R88G-VRSF15D750CJ	110.0	61	80	98	90	115	90	75	18	5	10
	1/25	R88G-VRSF25D750CJ	110.0	61	80	98	90	115	90	75	18	5	10

**Note 1.** The standard models have a straight shaft with a key.

**Note 2.** The diameter of the motor shaft insertion hole is the same as the shaft diameter of the corresponding motors.

### Outline Drawings

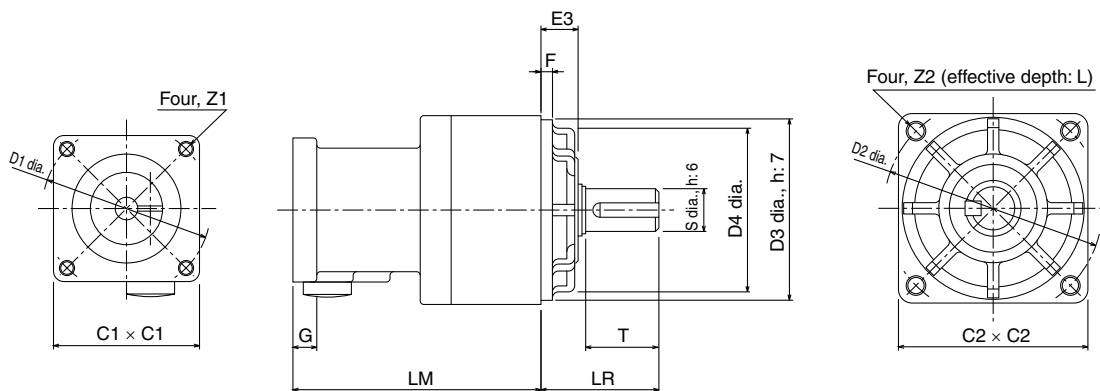

## 2-2 External and Mounting Hole Dimensions

Model			Dimensions (mm)									
			S	T	Z1	Z2	AT	L	Key dimensions			
									QK	b	h	t1
50 W	1/5	R88G-VRSF05B100CJ	12	20	M4	M5	M3	12	16	4	4	2.5
	1/9	R88G-VRSF09B100CJ	12	20	M4	M5	M3	12	16	4	4	2.5
	1/15	R88G-VRSF15B100CJ	12	20	M4	M5	M3	12	16	4	4	2.5
	1/25	R88G-VRSF25B100CJ	12	20	M4	M5	M3	12	16	4	4	2.5
100 W	1/5	R88G-VRSF05B100CJ	12	20	M4	M5	M3	12	16	4	4	2.5
	1/9	R88G-VRSF09B100CJ	12	20	M4	M5	M3	12	16	4	4	2.5
	1/15	R88G-VRSF15B100CJ	12	20	M4	M5	M3	12	16	4	4	2.5
	1/25	R88G-VRSF25B100CJ	12	20	M4	M5	M3	12	16	4	4	2.5
200 W	1/5	R88G-VRSF05B200CJ	12	20	M4	M5	M4	12	16	4	4	2.5
	1/9	R88G-VRSF09C200CJ	19	30	M4	M6	M4	20	22	6	6	3.5
	1/15	R88G-VRSF15C200CJ	19	30	M4	M6	M4	20	22	6	6	3.5
	1/25	R88G-VRSF25C200CJ	19	30	M4	M6	M4	20	22	6	6	3.5
400 W	1/5	R88G-VRSF05C400CJ	19	30	M4	M6	M4	20	22	6	6	3.5
	1/9	R88G-VRSF09C400CJ	19	30	M4	M6	M4	20	22	6	6	3.5
	1/15	R88G-VRSF15C400CJ	19	30	M4	M6	M4	20	22	6	6	3.5
	1/25	R88G-VRSF25C400CJ	19	30	M4	M6	M4	20	22	6	6	3.5
750 W	1/5	R88G-VRSF05C750CJ	19	30	M5	M6	M4	20	22	6	6	3.5
	1/9	R88G-VRSF09D750CJ	24	40	M5	M8	M4	20	30	8	7	4
	1/15	R88G-VRSF15D750CJ	24	40	M5	M8	M4	20	30	8	7	4
	1/25	R88G-VRSF25D750CJ	24	40	M5	M8	M4	20	30	8	7	4

### Outline Drawings

Set bolt (AT)

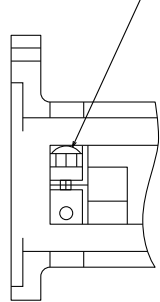

Key Dimensions

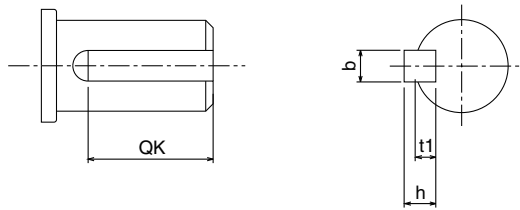

## 2-2 External and Mounting Hole Dimensions

### Decelerators for 3,000-r/min Flat Servomotors

Model		Dimensions (mm)											
		LM	LR	C1	C2	D1	D2	D3	D4	E3	F	G	
100 W	1/5	R88G-VRSF05B100PCJ	67.5	32	60	52	70	60	50	45	10	3	8
	1/9	R88G-VRSF09B100PCJ	67.5	32	60	52	70	60	50	45	10	3	8
	1/15	R88G-VRSF15B100PCJ	78.0	32	60	52	70	60	50	45	10	3	8
	1/25	R88G-VRSF25B100PCJ	78.0	32	60	52	70	60	50	45	10	3	8
200 W	1/5	R88G-VRSF05B200PCJ	72.5	32	80	52	90	60	50	45	10	3	12
	1/9	R88G-VRSF09C200PCJ	89.5	50	80	78	90	90	70	62	17	3	12
	1/15	R88G-VRSF15C200PCJ	100.0	50	80	78	90	90	70	62	17	3	12
	1/25	R88G-VRSF25C200PCJ	100.0	50	80	78	90	90	70	62	17	3	12
400 W	1/5	R88G-VRSF05C400PCJ	89.5	50	80	78	90	90	70	62	17	3	12
	1/9	R88G-VRSF09C400PCJ	89.5	50	80	78	90	90	70	62	17	3	12
	1/15	R88G-VRSF15C400PCJ	100.0	50	80	78	90	90	70	62	17	3	12
	1/25	R88G-VRSF25C400PCJ	100.0	50	80	78	90	90	70	62	17	3	12

**Note 1.** The standard models have a straight shaft with a key.

**Note 2.** The diameter of the motor shaft insertion hole is the same as the shaft diameter of the corresponding motors.

### Outline Drawings

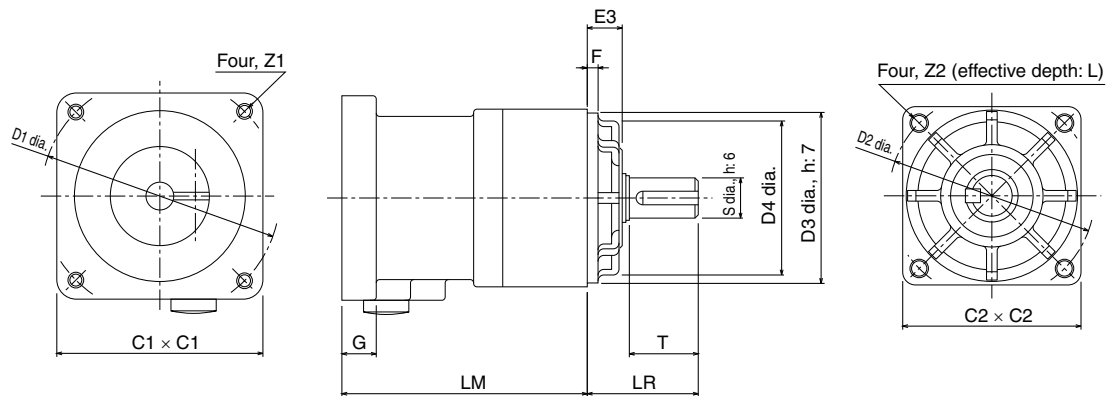



## 2-2 External and Mounting Hole Dimensions

Model			Dimensions (mm)									
			S	T	Z1	Z2	AT	L	Key dimensions			
									QK	b	h	t1
100 W	1/5	R88G-VRSF05B100PCJ	12	20	M4	M5	M3	12	16	4	4	2.5
	1/9	R88G-VRSF09B100PCJ	12	20	M4	M5	M3	12	16	4	4	2.5
	1/15	R88G-VRSF15B100PCJ	12	20	M4	M5	M3	12	16	4	4	2.5
	1/25	R88G-VRSF25B100PCJ	12	20	M4	M5	M3	12	16	4	4	2.5
200 W	1/5	R88G-VRSF05B200PCJ	12	20	M5	M5	M4	12	16	4	4	2.5
	1/9	R88G-VRSF09C200PCJ	19	30	M5	M6	M4	20	22	6	6	3.5
	1/15	R88G-VRSF15C200PCJ	19	30	M5	M6	M4	20	22	6	6	3.5
	1/25	R88G-VRSF25C200PCJ	19	30	M5	M6	M4	20	22	6	6	3.5
400 W	1/5	R88G-VRSF05C400PCJ	19	30	M5	M6	M4	20	22	6	6	3.5
	1/9	R88G-VRSF09C400PCJ	19	30	M5	M6	M4	20	22	6	6	3.5
	1/15	R88G-VRSF15C400PCJ	19	30	M5	M6	M4	20	22	6	6	3.5
	1/25	R88G-VRSF25C400PCJ	19	30	M5	M6	M4	20	22	6	6	3.5

### Outline Drawings

Set bolt (AT)

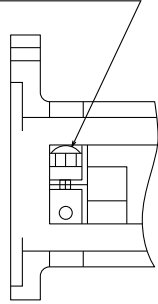

Key Dimensions

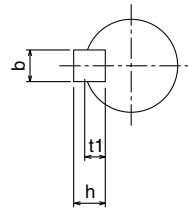
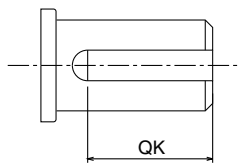

# External Regeneration Resistor Dimensions

## External Regeneration Resistor

### R88A-RR08050S/-RR080100S

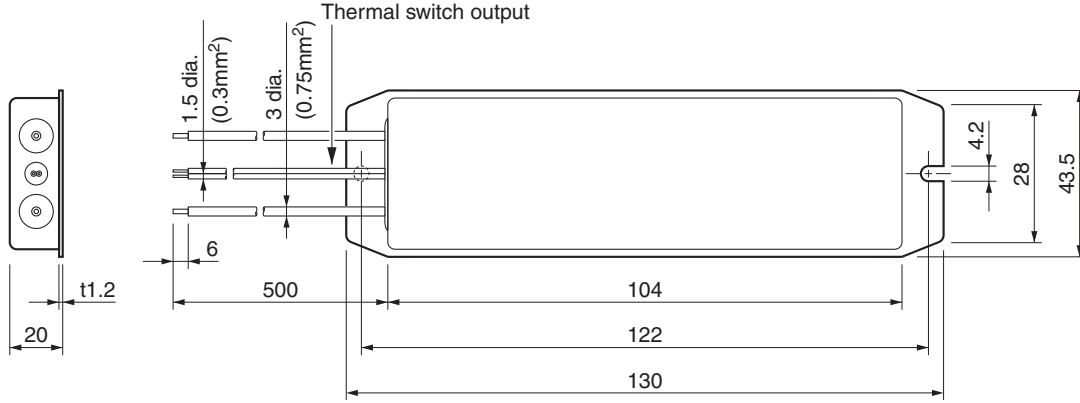

### R88A-RR22047S1

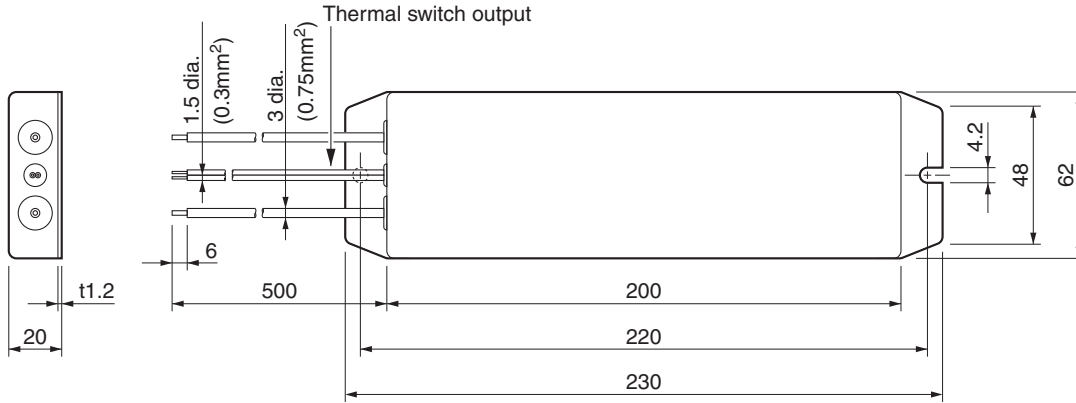

### R88A-RR50020S

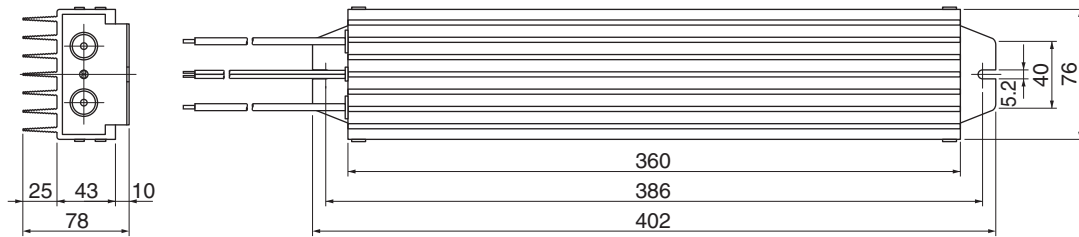

Reactor Dimensions

■ 3G3AX-DL2002

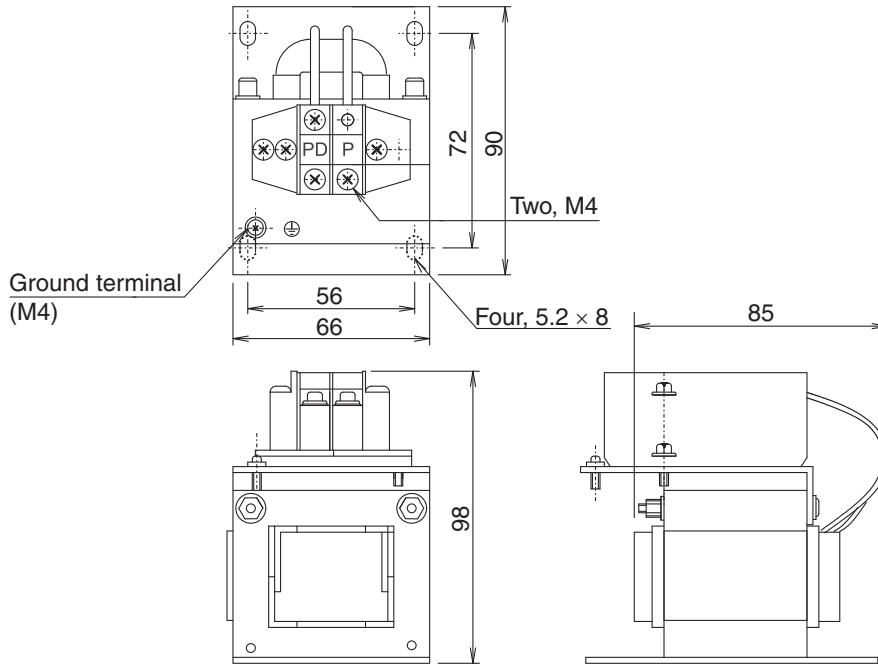

■ 3G3AX-DL2004

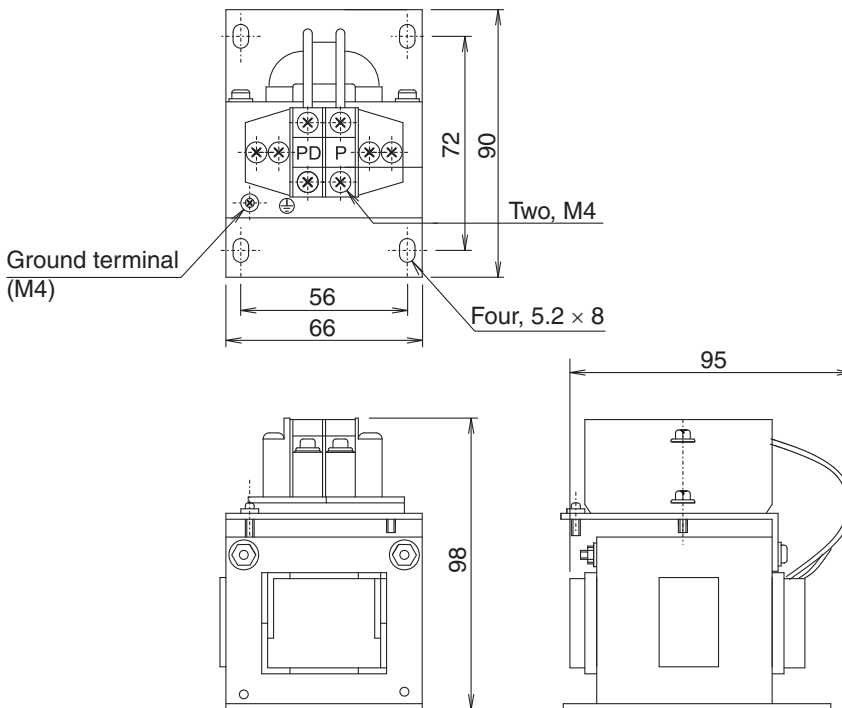

## 2-2 External and Mounting Hole Dimensions

### ■ 3G3AX-DL2007

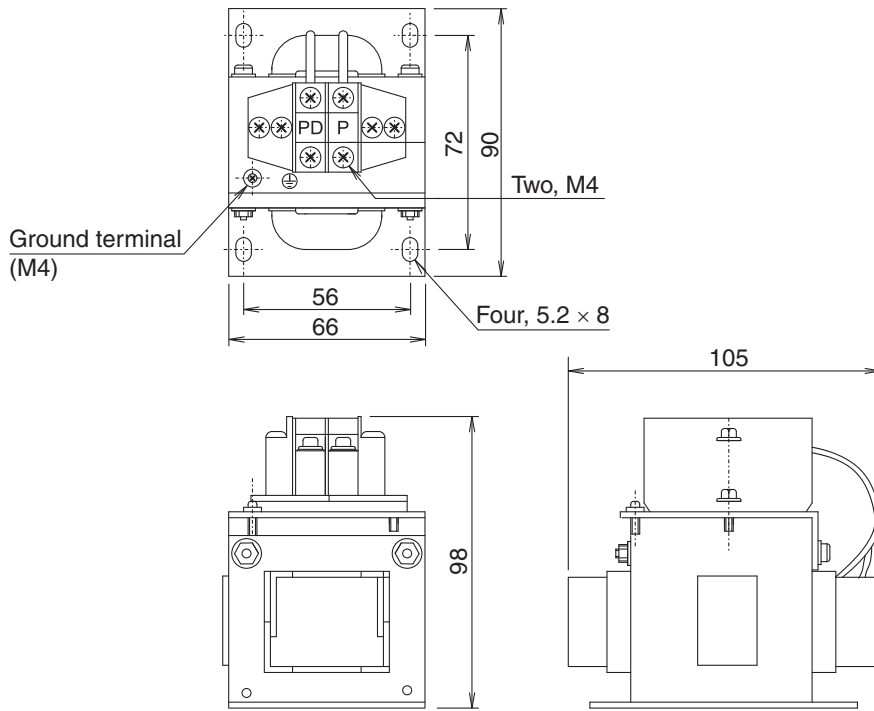

### ■ 3G3AX-DL2015

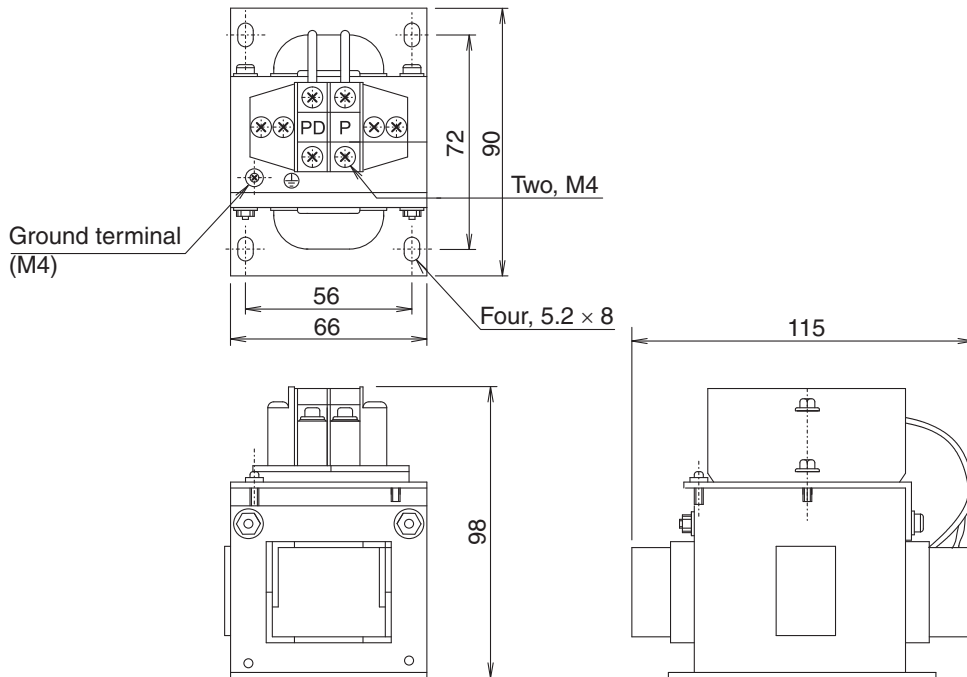

■ 3G3AX-DL2022

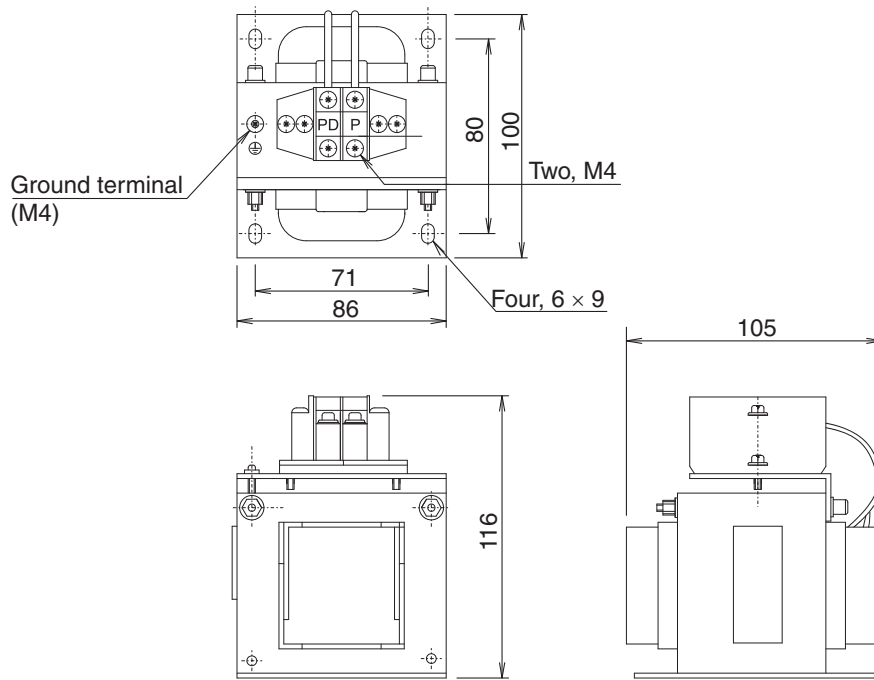

■ 3G3AX-AL2025/-AL2055

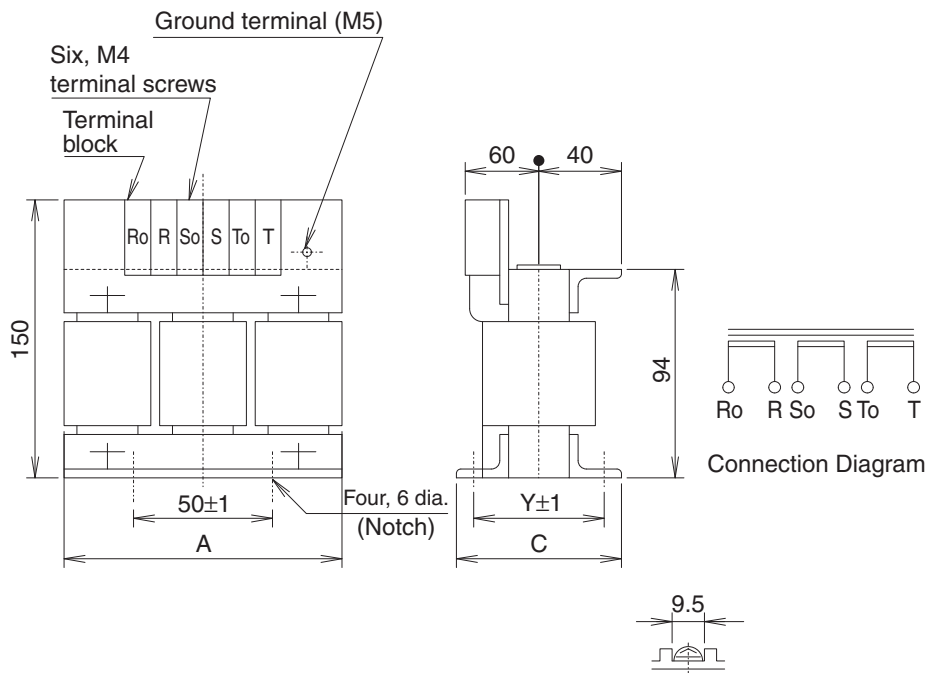

Model	Dimensions (mm)		
	A	C	Y
3G3AX-AL2025	120	82	67
3G3AX-AL2055	120	98	75

## 2-2 External and Mounting Hole Dimensions

### ■ 3G3AX-AL2110/-AL2220

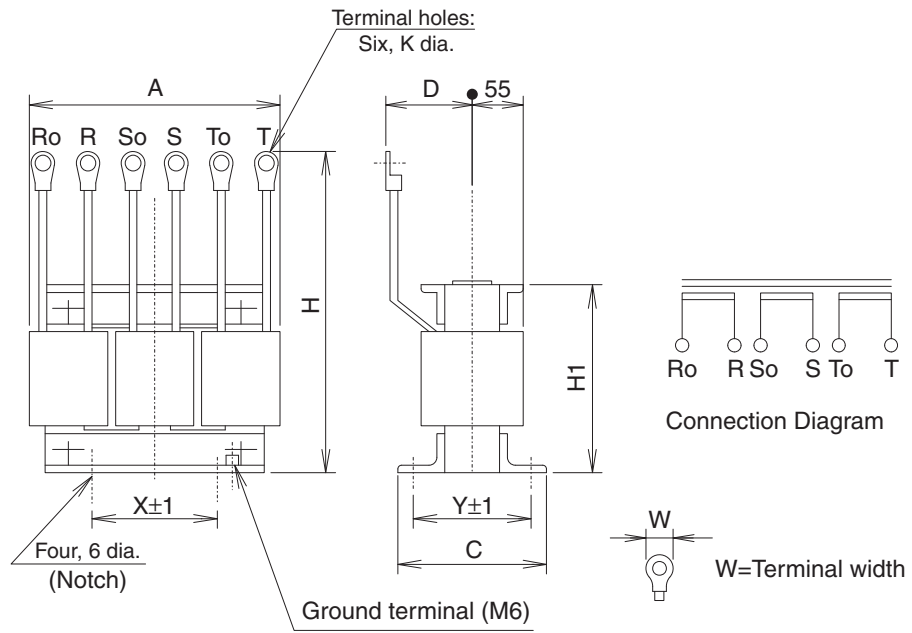

Model	Dimensions (mm)								
	A	C	D	H	H1	X	Y	K	W
3G3AX-AL2110	150	103	70	170	108	60	80	5.3	12
3G3AX-AL2220	180	113	75	190	140	90	90	8.4	16.5

# Chapter 3

## Specifications

3-1	Servo Drive Specifications .....	3-1
	General Specifications .....	3-1
	Characteristics .....	3-2
	Main Circuit and Servomotor Connections .....	3-6
	Control I/O Connector Specifications (CN1) .....	3-9
	Control Input Circuits .....	3-17
	Control Input Details .....	3-20
	Control Output Circuits.....	3-26
	Control Output Details.....	3-27
	Encoder Connector Specifications (CN2) .....	3-30
	Parameter Unit Connector Specifications (CN3B) .....	3-31
3-2	Servomotor Specifications .....	3-32
	General Specifications .....	3-32
	Characteristics .....	3-33
	Encoder Specifications .....	3-46
3-3	Decelerator Specifications .....	3-47
	Standard Models and Specifications.....	3-47
3-4	Cable and Connector Specifications .....	3-57
	Encoder Cable Specifications .....	3-57
	Absolute Encoder Battery Cable Specifications.....	3-63
	Servomotor Power Cable Specifications.....	3-64
	Communications Cable Specifications.....	3-84
	Connector Specifications .....	3-86
	Control Cable Specifications.....	3-89
3-5	Servo Relay Units and Cable Specifications .....	3-99
	Servo Relay Units Specifications .....	3-99
	Servo Drive-Servo Relay Unit Cable Specifications .....	3-112
	Position Control Unit-Servo Relay Unit Cable Specifications .....	3-116
3-6	Parameter Unit Specifications .....	3-129
3-7	External Regeneration Resistor Specifications .....	3-130
	External Regeneration Resistor Specifications.....	3-130
3-8	Reactor Specifications .....	3-132

# 3-1 Servo Drive Specifications

Select the Servo Drive matching the Servomotor to be used. (For details, refer to *Servo Drive-Servomotor Combinations* on page 2-5.)

The same OMNUC G-Series Servo Drive can be used for either a pulse string input or analog input. You can change the control mode according to the Controller. (The default setting is for position control with pulse string commands.)

3

## General Specifications

Item		Specifications	
Ambient operating temperature and operating humidity		0 to 55°C, 90% RH max. (with no condensation)	
Ambient storage temperature and storage humidity		-20 to 65°C, 90% RH max. (with no condensation)	
Storage and operating atmosphere		No corrosive gasses	
Vibration resistance		Smaller of either 10 to 60 Hz with double amplitude of 0.1 mm or acceleration of 5.88 m/s <sup>2</sup> max. in X, Y, and Z directions.	
Impact resistance		Acceleration of 19.6 m/s <sup>2</sup> max. 2 times each in X, Y, and Z directions	
Insulation resistance		Between power supply/power line terminals and frame ground: 0.5 MΩ. min. (at 500 VDC)	
Dielectric strength		Between power supply/power line terminals and frame ground: 1,500 VAC for 1 min at 50/60 Hz Between each control signal and frame ground: 500 VAC for 1 min	
Protective structure		Built into panel (IP10).	
International standards	EC Directives	EMC Directive	EN 55011 class A group 1
		Low-voltage Directive	EN 61000-6-2, IEC 61000-4-2/-3/-4/-5/-6/-11
	UL standards	UL standards	EN 50178
		CSA standards	UL 508C
		Korean Radio Regulations (KC)	CSA 22.2 No.14
			Compliant

**Note 1.** The above items reflect individual evaluation testing. The results may differ under compound conditions.

**Note 2.** Never perform withstand-voltage or other megameter tests on the Servo Drive. Doing so may damage the internal elements.

**Note 3.** Depending on the operating conditions, some Servo Drive parts will require maintenance. Refer to *8-5 Periodic Maintenance* on page 8-21.

**Note 4.** The service life of the Servo Drive is 28,000 hours at an average ambient temperature of 55°C at 100% of the rated torque.



## Characteristics

### ■ Servo Drives with 100-VAC Input Power

Item			R88D-GTA5L	R88D-GT01L	R88D-GT02L	R88D-GT04L
Continuous output current (rms)			1.3 A	1.8 A	2.4 A	4.9 A
Momentary maximum output current (rms)			3.9 A	5.4 A	7.2 A	14.7 A
Input power supply	Main circuit	Power supply capacity	0.4 KVA	0.4 KVA	0.5 KVA	0.9 KVA
		Power supply voltage	Single-phase 100 to 115 VAC (85 to 127 V), 50/60 Hz			
		Rated current	1.4 A	2.2 A	3.7 A	6.6 A
	Control circuit	Power supply voltage	Single-phase 100 to 115 VAC (85 to 127 V), 50/60 Hz			
		Rated current	0.09 A	0.09 A	0.09 A	0.09 A
Heat generated	Main circuit		10.1 W	14.4 W	18.4 W	41.4 W
	Control circuit		4.4 W	4.4 W	4.4 W	4.4 W
Control method			All-digital servo			
Inverter method			IGBT-driven PWM method			
PWM frequency			12.0 kHz		6.0 kHz	
Weight			Approx. 0.8 kg	Approx. 0.8 kg	Approx. 1.1 kg	Approx. 1.5 kg
Maximum applicable motor capacity			50 W	100 W	200 W	400 W
Applicable Servomotors	3,000-r/min Servomotors	<b>INC</b>	G05030H	G10030L	G20030L	G40030L
		<b>ABS</b>	G05030T	G10030S	G20030S	G40030S
	3,000-r/min Flat Servomotors	<b>INC</b>	---	GP10030L	GP20030L	GP40030L
		<b>ABS</b>	---	GP10030S	GP20030S	GP40030S
	2,000-r/min Servomotors	<b>ABS</b>	---	---	---	---
	1,000-r/min Servomotors	<b>ABS</b>	---	---	---	---
	Performance	Speed control range		1: 5000		
Speed variability: Load characteristic		0.01% or less at 0% to 100% (at rated speed)				
Speed variability: Voltage characteristic		0% at ±10% of rated voltage (at rated speed)				
Speed variability: Temperature characteristic		±0.1% or less at 0 to 50°C (at rated speed)				
Torque control reproducibility		±3%				

### 3-1 Servo Drive Specifications

#### ■ Servo Drives with Single-phase 200-VAC Input Power

Item			R88D-GT01H	R88D-GT02H	R88D-GT04H	R88D-GT08H	R88D-GT10H	R88D-GT15H	
Continuous output current (rms)			1.16 A	1.6 A	2.7 A	4.0 A	5.9 A	9.8 A	
Momentary maximum output current (rms)			3.5 A	5.3 A	7.1 A	14.1 A	21.2 A	28.3 A	
Input power supply	Main circuit	Power supply capacity	0.5 KVA	0.5 KVA	0.9 KVA	1.3 KVA	1.8 KVA	2.3 KVA	
		Power supply voltage	Single-phase 200 to 240 VAC (170 to 264 V), 50/60 Hz			Single-phase or three-phase 200 to 240 VAC (170 to 264 V), 50/60 Hz			
		Rated current	1.3 A	2.0 A	3.7 A	5.0/3.3 *1 A	7.5/4.1 *1 A	11/8.0 *1 A	
	Control circuit	Power supply voltage	Single-phase 200 to 240 VAC (170 to 264 V), 50/60 Hz						
		Rated current	0.05 A	0.05 A	0.05 A	0.05 A	0.07 A	0.07 A	
Heat generated	Main circuit		14.3 W	14.8 W	23.6 W	38.7 W	52.9 W	105.9 W	
	Control circuit		4.5 W	4.5 W	4.5 W	4.3 W	6.1 W	6.1 W	
PWM frequency			12.0 kHz			6.0 kHz			
Weight			Approx. 0.8 kg	Approx. 0.8 kg	Approx. 1.1 kg	Approx. 1.5 kg	Approx. 1.7 kg	Approx. 1.7 kg	
Maximum applicable motor capacity			100 W	200 W	400 W	750 W	1 k W	1.5 kW	
Applicable Servomotors	3,000-r/min Servomotors	<b>INC</b>	G05030H G10030H	G20030H	G40030H	G75030H	---	---	
		<b>ABS</b>	G05030T G10030T	G20030T	G40030T	G75030T	---	G1K030T G1K530T	
	3,000-r/min Flat Servomotors	<b>INC</b>	GP10030H	GP20030H	GP40030H	---	---	---	
		<b>ABS</b>	GP10030T	GP20030T	GP40030T	---	---	---	
	2,000-r/min Servomotors	<b>ABS</b>	---	---	---	---	G1K020T	G1K520T	
	1,000-r/min Servomotors	<b>ABS</b>	---	---	---	---	---	G90010T	
Control method			All-digital servo						
Inverter method			IGBT-driven PWM method						
Performance	Speed control range		1:5000						
	Speed variability: Load characteristic		0.01% or less at 0% to 100% (at rated speed)						
	Speed variability: Voltage characteristic		0% at ±10% of rated voltage (at rated speed)						
	Speed variability: Temperature characteristic		±0.1% or less at 0 to 50°C (at rated speed)						
	Torque control reproducibility		±3%						

\*1. The left value is for single-phase input power and the right value is for three-phase input power.

■ Servo Drives with Three-phase 200-VAC Input Power

Item			R88D-GT20H	R88D-GT30H	R88D-GT50H	R88D-GT75H
Continuous output current (rms)			14.3 A	17.4 A	31.0 A	45.4 A
Momentary maximum output current (rms)			45.3 A	63.6 A	84.8 A	170.0 A
Input power supply	Main circuit	Power supply capacity	3.3 KVA	4.5 KVA	7.5 KVA	11 KVA
		Power supply voltage	Three-phase 200 to 230 VAC (170 to 253 V), 50/60 Hz			
		Rated current	10.2 A	15.2 A	23.7 A	35.0 A
	Control circuit	Power supply voltage	Single-phase 200 to 230 VAC (170 to 253 V), 50/60 Hz			
		Rated current	0.1 A	0.12 A	0.12 A	0.14 A
Heat generated	Main circuit		112.3 W	219.6 W	391.7 W	376.2 W
	Control circuit		10.7 W	13.3 W	13.3 W	13.8 W
PWM frequency			6.0 kHz			
Weight			Approx. 3.2 kg	Approx. 6.0 kg	Approx. 6.0 kg	Approx. 16.4 kg
Maximum applicable motor capacity			2 kW	3 kW	5 kW	7.5 kW
Applicable Servomotors	3,000-r/min Servomotors	<b>INC</b>	---	---	---	---
		<b>ABS</b>	G2K030T	G3K030T	G4K030T G5K030T	---
	3,000-r/min Flat Servomotors	<b>INC</b>	---	---	---	---
		<b>ABS</b>	---	---	---	---
	2,000-r/min Servomotors	<b>ABS</b>	G2K020T	G3K020T	G4K020T G5K020T	G7K515T
	1,000-r/min Servomotors	<b>ABS</b>	---	G2K010T	G3K010T G4K510T	G6K010T
Control method			All-digital servo			
Inverter method			IGBT-driven PWM method			
Performance	Speed control range		1:5000			
	Speed variability: Load characteristic		0.01% or less at 0% to 100% (at rated speed)			
	Speed variability: Voltage characteristic		0% at ±10% of rated voltage (at rated speed)			
	Speed variability: Temperature characteristic		±0.1% or less at 0 to 50°C (at rated speed)			
	Torque control reproducibility		±3%			

### 3-1 Servo Drive Specifications

#### ■ Protective Functions

Error detection	Description
Control power supply undervoltage	The voltage between P and N in the control voltage converter has dropped below the specified value.
Overvoltage	The voltage between P and N in the converter has exceeded the specified value.
Undervoltage	The main power supply between L1–L3 was interrupted for longer than the time set in the Momentary Hold Time (Pn6D) when the Undervoltage Alarm Selection (Pn65) was set to 1. Alternatively, the voltage between P and N in the main power supply converter dropped below the specified value while the Servo Drive was ON.
Overcurrent	The current flowing to the converter exceeded the specified value.
Overheating	The temperature of the Servo Drive radiator or power elements exceeded the specified value.
Overload	The torque command value exceeded the level set in the Overload Detection Level Setting (Pn72), resulting in an overload due to the time characteristics.
Regeneration overload	The regenerative energy exceeded the capacity of the regeneration resistor.
Encoder communications error	The disconnection detection function was activated because communications between the encoder and Servo Drive were interrupted for a specified number of times.
Encoder communications data error	There was an error in the communications data from the encoder. (The encoder is connected, but there is an error in the communications data.)
Deviation counter overflow	The number of position deviation pulses exceeded the Deviation Counter Overflow Level (Pn70).
Overspeed	The rotation speed of the Servomotor exceeded the setting of the Overspeed Detection Level Setting (Pn73).
Command pulse multiplying error	The settings of the gear ratio (Pn48 to Pn4B: Electronic Gear Ratio Numerator 1, Electronic Gear Ratio Numerator 2, Electronic Gear Ratio Numerator Exponent and Electronic Gear Ratio Denominator) are not appropriate.
Overrun limit error	The allowable range of movement set in the Overrun Limit Setting (Pn26) was exceeded by the Servomotor.
EEPROM parameter error	The data in the parameter storage area was corrupted when the data was read from EEPROM at power-ON.
EEPROM check code error	The EEPROM write verification data was corrupted when the data was read from EEPROM at power-ON.
Drive prohibit input	Both the forward and reverse drive prohibit inputs were open when the Drive Prohibit Input Selection (Pn04) was set to 0 or either the forward or reverse drive prohibit input was open when the Drive Prohibit Input Selection (Pn04) was set to 2.
Excessive analog input	A voltage exceeding the Speed Command/ Torque Command Input Overflow Level Setting (Pn71) was applied to the Speed Command Input (REF: CN1 pin 14).
Absolute encoder system down error <b>ABS</b>	The power supply and battery to the absolute encoder went down and the capacitor voltage dropped below the specified value.
Absolute encoder counter overflow error <b>ABS</b>	The multiturn counter for the absolute encoder has exceeded the specified value.
Absolute encoder overspeed error <b>ABS</b>	The Servomotor speed exceeded the specified value when the power to the absolute encoder was interrupted and power was supplied only from the battery.
Absolute encoder one-turn counter error <b>ABS</b>	An error was detected in the one-turn counter for the absolute encoder.
Absolute encoder multi-turn counter error <b>ABS</b>	An error was detected in the multiturn counter for the absolute encoder.
Absolute encoder status error <b>ABS</b>	The number of rotations of the encoder exceeded the specified value when the power supply was turned ON.
Encoder phase Z error	A phase Z pulse was not detected regularly for the serial encoder.
Encoder PS signal error	A logic error in the PS signal was detected for the serial encoder.
PCL input exceeded	A voltage exceeding $\pm 10$ V was applied to the Forward Torque Limit Input (PCL: CN1 pin 16).
NCL input exceeded	A voltage exceeding $\pm 10$ V was applied to the Reverse Torque Limit Input (NCL: CN1 pin 18).
Motor automatic recognition error	The Servomotor and Servo Drive do not match.
CPU error	The Servo Drive or Servomotor failed.
Encoder error	The Servo Drive or Servomotor failed.

**Main Circuit and Servomotor Connections**

When wiring the main circuit, use proper wire sizes, grounding systems, and anti-noise measures.

**■ R88D-GTA5L/-GT01L/-GT02L/-GT04L  
R88D-GT01H/-GT02H/-GT04H/-GT08H/-GT10H/-GT15H**

**Main Circuit Connector Specifications (CNA)**

Symbol	Name	Function
L1	Main circuit power supply input	R88D-GT□L (50 W to 400 W): Single-phase 100 to 115 VAC (85 to 127 V), 50/60 Hz
L2		R88D-GT□H (50 W to 1.5 kW): Single-phase 200 to 240 VAC (170 to 264 V), 50/60 Hz (750 W to 1.5 kW): Three-phase 200 to 240 VAC (170 to 264 V), 50/60 Hz
L3		
L1C	Control circuit power supply input	R88D-GT□L: Single-phase 100 to 115 VAC (85 to 127 V) 50/60 Hz
L2C		R88D-GT□H: Single-phase 200 to 240 VAC (170 to 264 V) 50/60 Hz

**Servomotor Connector Specifications (CNB)**

Symbol	Name	Function
B1	External Regeneration Resistor connection terminals	R88D-GTA5L/-GT01L/-GT02L/-GT01H/-GT02H/-GT04H: These terminals normally do not need to be connected. If there is high regenerative energy, connect an External Regeneration Resistor between B1 and B2.  R88D-GT04L/-GT08H/-GT10H/-GT15H: Normally B2 and B3 are connected. If there is high regenerative energy, remove the short-circuit bar between B2 and B3 and connect an External Regeneration Resistor between B1 and B2.
B2		
B3		
U	Servomotor connection terminals	These are the output terminals to the Servomotor. Be sure to wire them correctly.
V		
W		
⊕		
⊕	Frame ground	This is the ground terminal. Ground to a 100 Ω or less.

### 3-1 Servo Drive Specifications

#### ■ R88D-GT20H/-GT30H/-GT50H

##### Main Circuit Terminal Block Specifications

Symbol	Name	Function	
L1	Main circuit power supply input	R88D-GT□H (2 to 5 kW): Three-phase 200 to 230 VAC (170 to 253 V), 50/60Hz	
L2			
L3			
L1C	Control circuit power supply input	R88D-GT□H: Single-phase 200 to 230 VAC (170 to 253V), 50/60 Hz	
L2C			
B1	External Regeneration Resistor connection terminals	2 to 5 kW: Normally B2 and B3 are connected. If there is high regenerative energy, remove the short-circuit bar between B2 and B3 and connect an External Regeneration Resistor between B1 and B2.	
B2			
B3			
U	Servomotor connection terminals	Red	These are the output terminals to the Servomotor. Be sure to wire them correctly.
V		White	
W		Blue	
⊕		Green/ Yellow	
⊕	Frame ground	This is the ground terminal. Ground to 100 Ω or less.	

3

Specifications

■ R88D-GT75H

**Main Circuit Terminal Block Specifications (TB1)**

Symbol	Name	Function	
L1	Main circuit power supply input	R88D-GT75H (6 to 7.5 kW): Three-phase 200 to 230 VAC (170 to 253 V), 50/60Hz	
L2			
L3			
B1	External Regeneration Resistor connection terminals	6 kW, 7.5 kW: A regeneration resistor is not built in. Connect an External Regeneration Resistor between B1 and B2, if necessary.	
B2			
U	Servomotor connection terminals	Red	These are the output terminals to the Servomotor. Be sure to wire them correctly.
V		White	
W		Blue	
⊕		Green/ Yellow	
⊕	Frame ground	This is the ground terminal. Ground to 100 Ω or less.	

**Main Circuit Terminal Block Specifications (TB2)**

Symbol	Name	Function
NC	---	Do not connect.
L1C	Control circuit power supply input	R88D-GT75H: Single-phase 200 to 230 VAC (170 to 253 V), 50/60Hz
L2C		
⊕	Frame ground	This is the ground terminal. Ground to 100 Ω or less.
NC	---	Do not connect.
EX1		
EX2		
EX3		
NC		
FN(+)	Fan Stop Output	Outputs a warning signal when the fan inside the Servo Drive stops. (30 VDC, 50 mA max.)
FN(-)		

Specifications

Control I/O Connector Specifications (CN1)

Control I/O Signal Connections and External Signal Processing for Position Control

3

Specifications

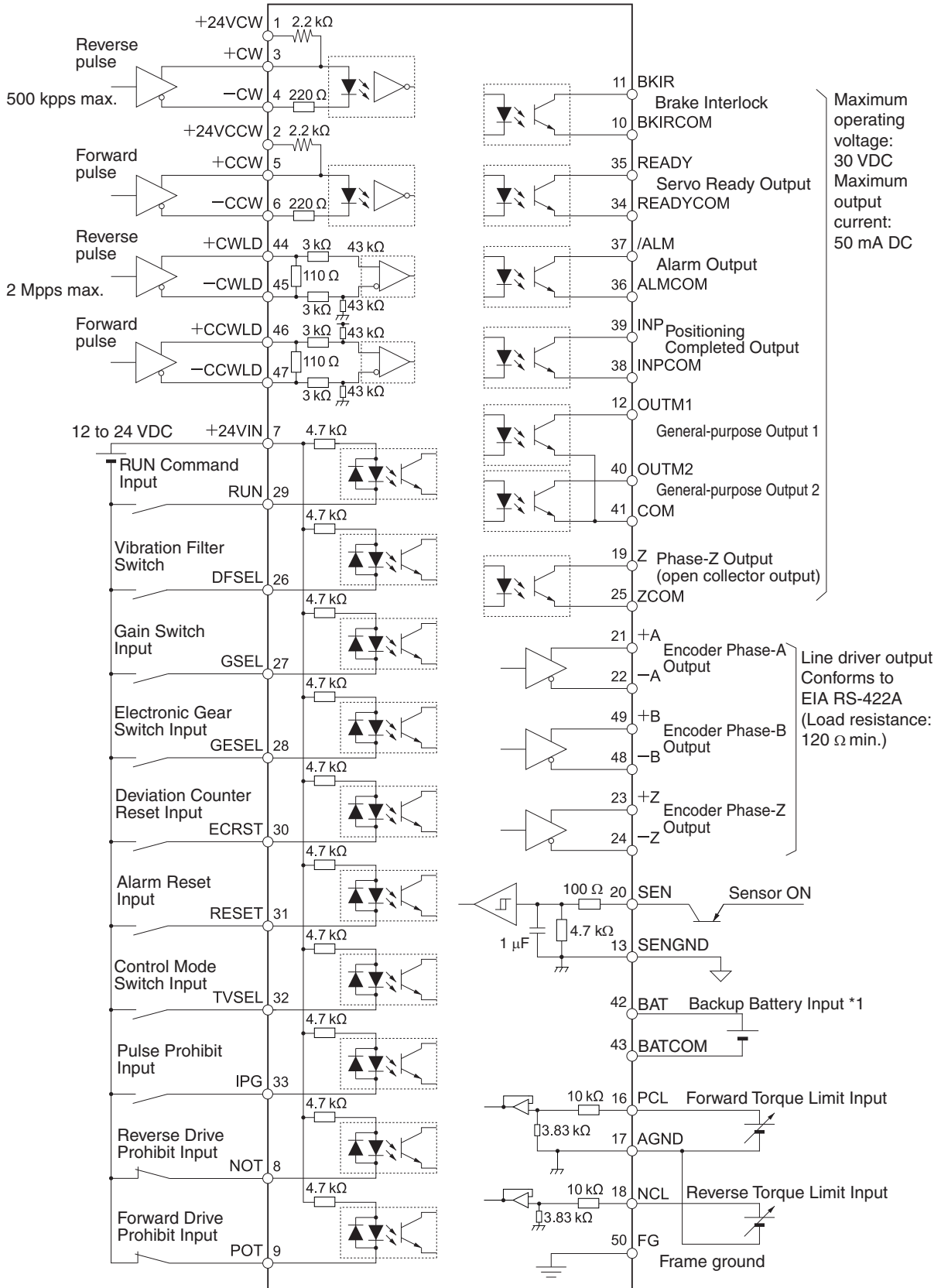

Maximum operating voltage: 30 VDC  
Maximum output current: 50 mA DC

Line driver output  
Conforms to EIA RS-422A  
(Load resistance: 120 Ω min.)

\*1. If a backup battery is connected, a cable with a battery is not required.



■ Control I/O Signal Connections and External Signal Processing for Speed Control

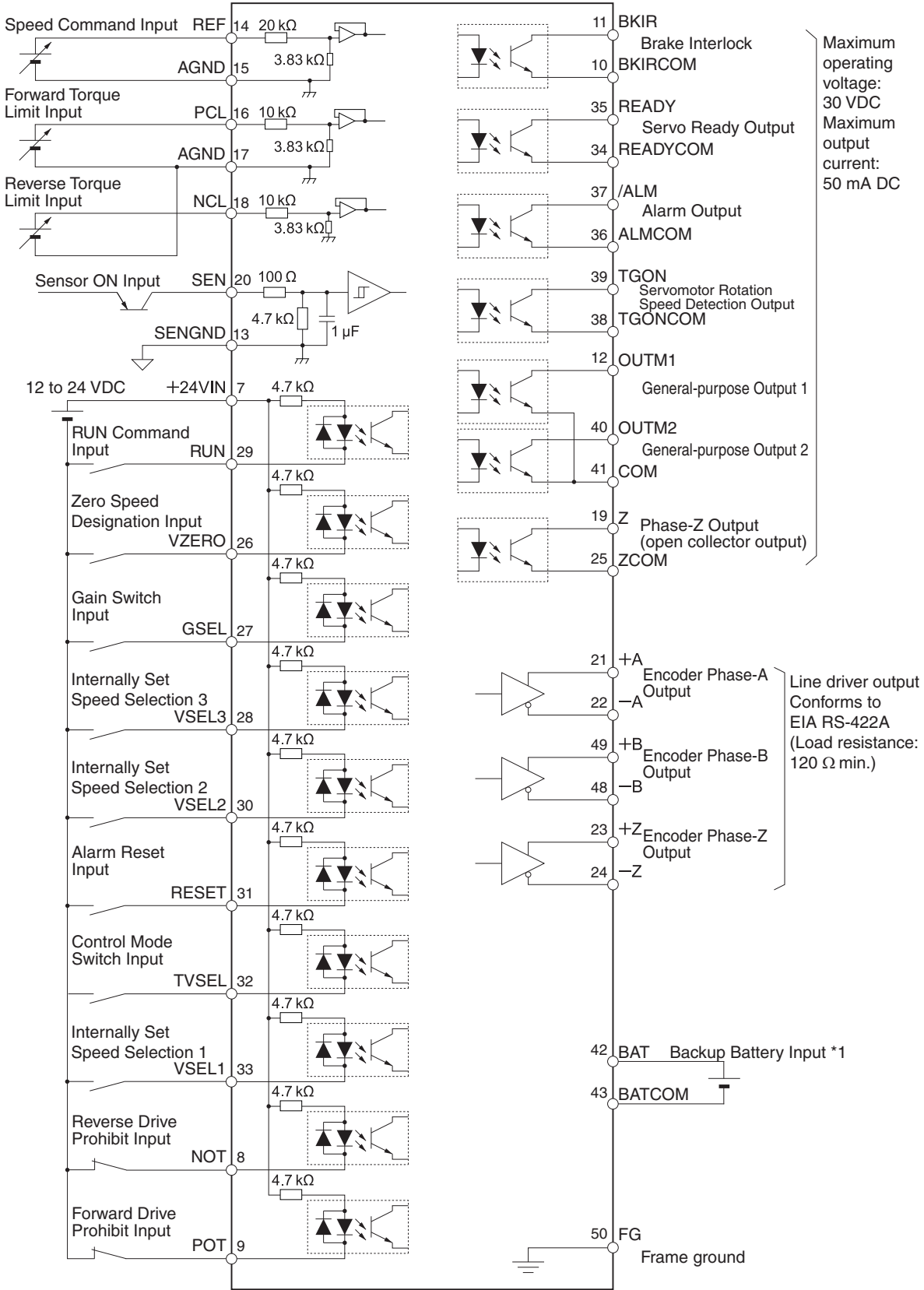

\*1. If a backup battery is connected, a cable with a battery is not required.

### 3-1 Servo Drive Specifications

#### Control I/O Signal Connections and External Signal Processing for Torque Control

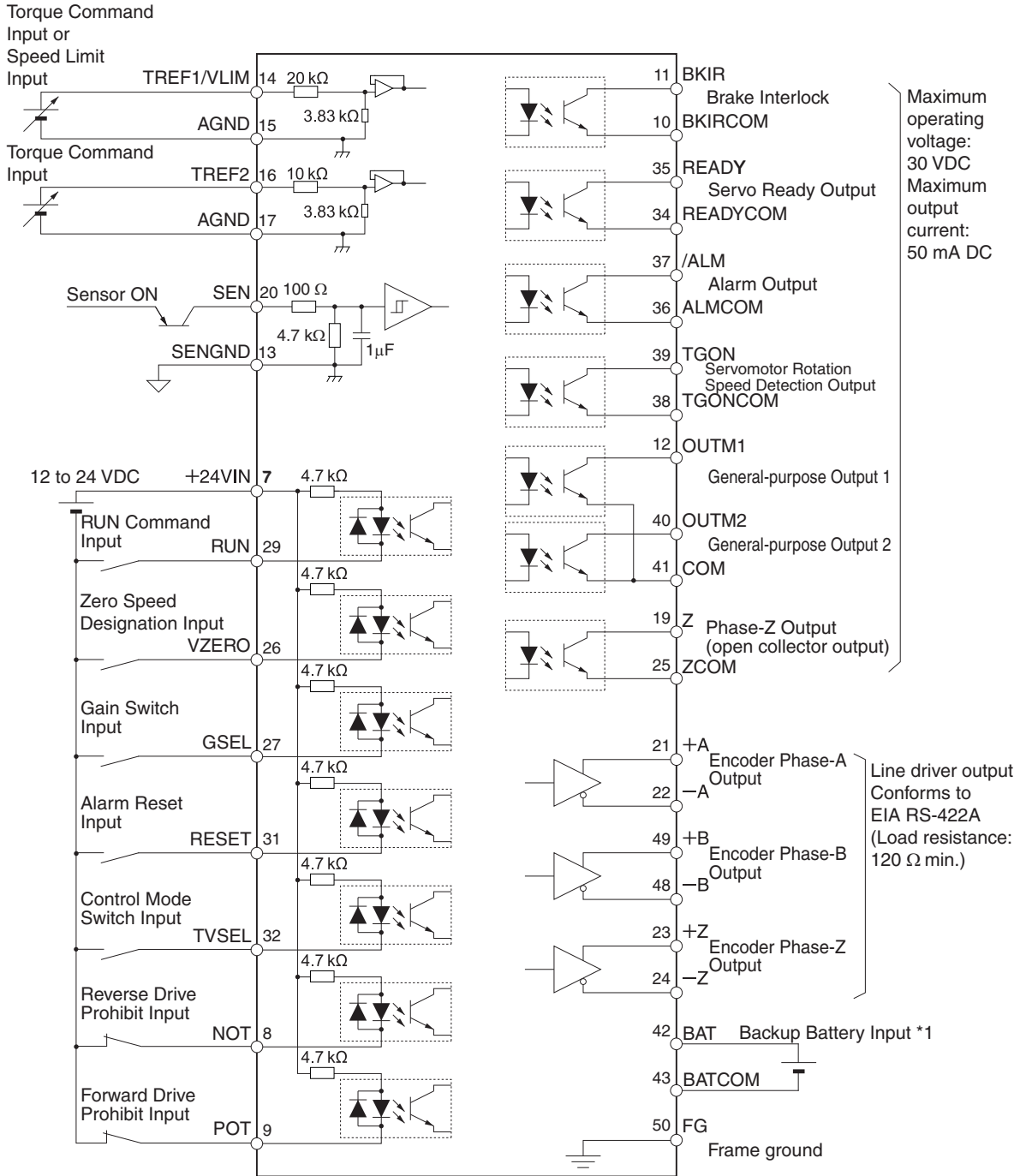

\*1. If a backup battery is connected, a cable with a battery is not required.

■ Control I/O Signals

CN1 Control Inputs

Pin No.	Symbol	Name	Function/Interface	Control mode
1	+24VCW	24-V Open-collector Input for Command Pulse	Input terminals for position command pulses. These are selected by setting the Command Pulse Input Selection (Pn40) to 0. Line-Driver input: Maximum response frequency: 500 kpps Open-collector input: Maximum response frequency: 200 kpps Any of the following can be selected by using the Pn42 setting: reverse and forward pulses (CW/CCW), feed pulse and direction signal (PULS/SIGN), 90° phase difference (phase A/B) signals (FA/FB).	Position
2	+24VCCW	24-V Open-collector Input for Command Pulse		
3	+CW/PULS/FA	Reverse Pulses Input/ Feed Pulses Input, or 90° Phase Difference Pulse Input (Phase A)		
4	-CW/PULS/FA			
5	+CCW/SIGN/FB	Forward Pulse Input/ Direction Signal, or 90° Phase Difference Pulse Input (Phase B)		
6	-CCW/SIGN/FB			
7	+24VIN	12 to 24-VDC Power Supply Input	Power supply input terminal (+12 to 24 VDC) for sequence inputs.	All
8	NOT	Reverse Drive Prohibit Input	Reverse rotation overtravel input. OFF: Prohibited, ON: Permitted	All
9	POT	Forward Drive Prohibit Input	Forward rotation overtravel input. OFF: Prohibited, ON: Permitted	All
14	REF	Speed Command Input	Analog input terminal for speed commands. *1	Speed
	TREF1	Torque Command Input	Analog input terminal for torque command when Torque Command/Speed Limit Selection (Pn5B) is set to 0. *1	Torque
	VLIM	Speed Limit Input	Analog input terminal for speed limit when Torque Command/Speed Limit Selection (Pn5B) is set to 1. *1	Torque
15	AGND	Analog Input Ground	Analog input ground.	All
16	PCL	Forward Torque Limit Input	Analog input terminal for forward torque limit. *1	Position, speed
	TREF2	Torque Command Input	Analog input terminal for torque command by setting the Control Mode Selection (Pn02) and Torque Command/Speed Limit Selection (Pn5B). *1	Torque
17	AGND	Analog Input Ground	Analog input ground.	All
18	NCL	Reverse Torque Limit Input	Analog input terminal for reverse torque limit. *1	Position, speed
20	SEN	Sensor ON Input	ON: Absolute encoder's multi-turn amount and initial incremental pulses are sent. Required signal when using an absolute encoder.	All
13	SENGND			

### 3-1 Servo Drive Specifications

Pin No.	Symbol	Name	Function/Interface	Control mode
26	VZERO	Zero Speed Designation Input	When the Zero Speed Designation/Speed Command Direction Switch (Pn06) is set to 0, Zero Speed Designation Input is disabled. When the Zero Speed Designation/Speed Command Direction Switch (Pn06) is set to 1, Zero Speed Designation Input is enabled. OFF: Speed Command is regarded as 0. ON: Normal operation.	Speed, torque
	PNSEL	Speed Command Rotation Direction Switch	When the Zero Speed Designation/Speed Command Direction Switch (Pn06) is set to 0, Speed Command Direction Switch input is disabled. When the Zero Speed Designation/Speed Command Direction Switch (Pn06) is set to 2, it will determine the direction of the speed command. OFF: Forward rotation ON: Reverse rotation	Speed
	DFSEL	Vibration Filter Switch	Vibration filter switch input when the Vibration Filter Selection (Pn24) is set to 1. OFF: Vibration filter 1 (Pn2B, Pn2C) enabled. ON: Vibration filter 2 (Pn2D, Pn2E) enabled.	Position
27	GSEL	Gain Switch	Gain switch input when the Torque Limit Selection (Pn03) is set to 0 to 2. If the Gain Switching Input Operating Mode Selection (Pn30) is set to 0: OFF: PI (Proportional/Integral) operation ON: P (Proportional) operation When the Gain Switching Input Operating Mode Selection (Pn30) is set to 1, switches between Gain 1 and Gain 2. The selected Gain will differ depending on the settings for Pn31 and Pn36.	All
	TLSEL	Torque Limit Switch	Torque limit switch input when the Torque Limit Selection (Pn03) is set to 3. OFF: No. 1 Torque Limit (Pn5E) enabled. ON: No. 2 Torque Limit (Pn5F) enabled.	All
28	GESEL	Electronic Gear Switch	Electronic gear switch input. *2 OFF: Electronic Gear Ratio Numerator 1 (Pn48) ON: Electronic Gear Ratio Numerator 2 (Pn49)	Position
	VSEL3	Internally Set Speed Selection 3	Internally set speed selection 3. ON: Internally set speed selection 3 is input.	Speed
29	RUN	RUN Command	ON: Servo ON (Starts power to Servomotor.) *3	All
30	ECRST	Deviation Counter Reset Input	Deviation counter reset input. *4 ON: The deviation counter is reset (i.e., cleared).	Position
	VSEL2	Internally Set Speed Selection 2	Internally set speed selection 2. ON: Internally set speed selection 2 is input.	Speed
31	RESET	Alarm Reset Input	ON: Servo alarm status is reset. *5 Must be ON for 120 ms min.	All
32	TVSEL	Control Mode Switch Input	The control mode can be switched when the Control Mode Selection (Pn02) is set to 3 to 5.	All
33	IPG	Pulse Prohibit Input	Pulse prohibit input (IPG) when the Command Pulse Prohibited Input (Pn43) is set to 0. OFF: The command pulse is ignored.	Position
	VSEL1	Internally Set Speed Selection 1	Internally set speed selection 1. ON: Internally set speed selection 1 is input.	Speed

Pin No.	Symbol	Name	Function/Interface	Control mode
42	BAT	Backup Battery Input <b>ABS</b>	Backup battery connector terminals when the absolute encoder power is interrupted. When a backup battery is connected to this terminal, the battery case is not required.	All
43	BATGND			
44	+CWLD	Reverse Pulse (input for line driver only)	Position command pulse input when the Command Pulse Input Selection (Pn40) is set to 1. Line-driver input: Maximum response frequency: 2 Mpps	Position
45	-CWLD			
46	+CCWLD	Forward Pulse (input for line driver only)	Any of the following can be selected by using the Pn42 setting: reverse and forward pulses (CW/CCW), feed pulse and direction signal (PULS/SIGN), 90° phase difference (phase A/B) signals (FA/FB).	
47	-CCWLD			

\*1. Do not apply a voltage that exceeds  $\pm 10$  V.

\*2. Do not input a command pulse within 10 ms before and after switching.

\*3. Dynamic brake operation and deviation counter clear can be selected using the Stop Selection with Servo OFF (Pn69).

\*4. Must be ON for 100  $\mu$ s min.

\*5. The deviation counter is cleared when the alarm is reset. Some alarms cannot be reset with this input.

### 3-1 Servo Drive Specifications

#### ■ CN1 Control Outputs

Pin No.	Symbol	Name	Function/Interface	Control mode
10	BKIRCOM	Brake Interlock Output	Outputs holding brake timing signals. Releases the holding brake when ON.	All
11	BKIR			
12	OUTM1	General-purpose Output 1	Used according to the setting of the General-purpose Output 1 Selection (Pn0A).	All
19	Z	Phase-Z Output (open collector)	Outputs the encoder phase-Z signal (1 pulse/revolution). Open-collector output.	All
25	ZCOM	Phase-Z Output (open collector) common		
21	+A	Encoder Phase-A + Output	Outputs encoder pulses according to the Encoder Dividing Rate Setting (Pn44 and Pn45). This is the line-driver output (equivalent to RS-422).	All
22	-A	Encoder Phase-A - Output		
48	-B	Encoder Phase-B - Output		
49	+B	Encoder Phase-B + Output		
23	+Z	Encoder Phase-Z + Output		
24	-Z	Encoder Phase-Z - Output		
35	READY	Servo Ready Output	Output signal to indicate that power can be supplied to the Servo Drive. ON if no errors are found after the power is supplied to the main circuit.	All
34	READYCOM			
37	/ALM	Alarm Output	The output is OFF when an alarm is generated for the Servo Drive.	All
36	ALMCOM			
39	INP	Positioning Completed Output	Positioning completed output. ON: The accumulated pulses in the deviation counter are within the setting for Positioning Completion Range (Pn60).	Position
38	INPCOM			
39	TGON	Servomotor Rotation Speed Detection Output	Servomotor rotation speed detection output. ON: The number of Servomotor rotations exceeds the value set for Rotation Speed for Motor Rotation Detection (Pn62).	Speed, torque
38	TGONCOM			
40	OUTM2	General-purpose Output 2	Used according to the setting of the General-purpose Output 2 Selection (Pn09).	All
41	COM	General-purpose Output Common	Ground common for sequence outputs.	All
Shell	FG	Frame Ground	Connected to the ground terminal inside the Servo Drive.	All

■ CN1 Pin Arrangement

2	+24VCCW	24-V Open-collector Input for Command Pulse	1	+24VCW	24-V Open-collector Input for Command Pulse	27	GSEL/TLSEL	Gain Switch/Torque Limit Switch	26	VZERO/DFSEL/PNSEL	Zero Speed Designation Input/Vibration Filter Switch/Speed Command Rotation Direction Switch
4	-CW/ -PULS/-FA	Reverse Pulses Input/Feed Pulses Input, or 90° Phase Difference Pulse Input (Phase A)	3	+CW/ +PULS/+FA	Reverse Pulses Input/Feed Pulses Input, or 90° Phase Difference Pulse Input (Phase A)	29	RUN	RUN Command	28	GESEL/ VSEL3	Electronic Gear Switch/Internally Set Speed Selection 3
6	-CCW/ -SIGN/-FB	Forward Pulses/Direction Signal, or 90° Phase Difference Pulse Input (Phase B)	5	+CCW/ +SIGN/+FB	Forward Pulses/Direction Signal, or 90° Phase Difference Pulse Input (Phase B)	31	RESET	Alarm Reset Input	30	ECRST/VSEL2	Deviation Counter Reset/Internally Set Speed Selection 2
8	NOT	Reverse Drive Prohibit Input	7	+24VIN	12 to 24-VDC Power Supply Input	33	IPG/VSEL1	Pulse Prohibit Input/Internally Set Speed Selection 1	32	TVSEL	Control Mode Switch Input
10	BKIRCOM	Brake Interlock Output	9	POT	Forward Drive Prohibit Input	35	READY	Servo Ready Output	34	READYCOM	Servo Ready Output
12	OUTM1	General-purpose Output 1	11	BKIR	Brake Interlock Output	37	/ALM	Alarm Output	36	ALMCOM	Alarm Output
14	REF/TREF1/ VLIM	Speed Command Input/Torque Command Input/Speed Limit Input	13	SENGND	Ground Common	39	INP/TGON	Positioning Completed Output/Servomotor Rotation Speed Detection Output	38	INPCOM/ TGONCOM	Positioning Completed Output/Servomotor Rotation Speed Detection Output Common
16	PCL/TREF2	Forward Torque Limit Input/Torque Command Input	15	AGND	Sensor Input Ground	41	COM	General-purpose Output Common	40	OUTM2	General-purpose Output 2
18	NCL	Reverse Torque Limit Input	17	AGND	Sensor Input Ground	43	BATGND	Absolute Encoder Backup Battery Input	42	BAT	Absolute Encoder Backup Battery Input
20	SEN	Sensor ON Input	19	Z	Phase-Z Output (open collector)	45	-CWLD	Reverse Pulse (input for line driver only)	44	+CWLD	Reverse Pulse (input for line driver only)
22	-A	Encoder Phase-A Output	21	+A	Encoder Phase-A + Output	47	-CCWLD	Forward Pulse (input for line driver only)	46	+CCWLD	Forward Pulse (input for line driver only)
24	-Z	Encoder Phase-Z Output	23	+Z	Encoder Phase-Z + Output	49	+B	Encoder Phase-B + Output	48	-B	Encoder Phase-B - Output
			25	ZCOM	Phase-Z Output (open collector) Common				50	*	

**Note** Do not connect anything to unused pins (\*).

■ CN1 Connectors (50 Pins)

Name	Model	Manufacturer
Servo Drive Connector	52986-3679	Molex Japan
Cable Plug	10150-3000PE	Sumitomo 3M
Cable Case (Shell Kit)	10350-52A0-008	

Control Input Circuits

Speed Command/Torque Command Input

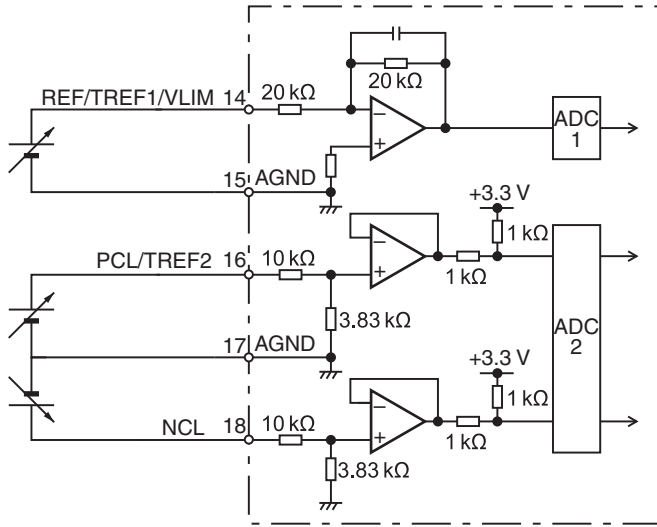

Precautions for Correct Use

The maximum allowable input voltage is  $\pm 10$  V for each input. The VR must be 2 k $\Omega$  with B characteristics and 1/2 W minimum. R must be 200  $\Omega$  and 1/2 W minimum.

Position Command Pulse Input (Line Receiver Input)

- When connecting with a line driver and a line receiver, up to 2 Mpps will be available. (+CWLD:44, -CWLD:45, +CCWLD:46, -CCWLD:47)

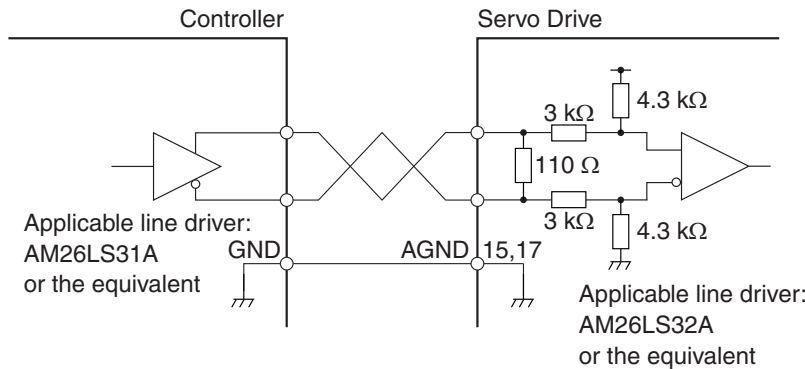

Precautions for Correct Use

The shielded twisted-pair cable should not exceed 20 m in length.

3 Specifications



■ Position Command Pulse Input (Photocoupler Input)

Line Driver Input (500 kpps Maximum)

(+CW:3, -CW:4, +CCW:5, -CCW:6)

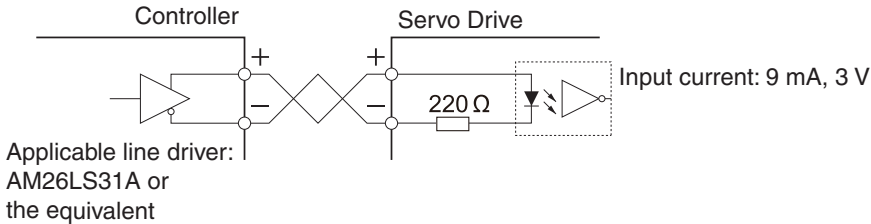

**Precautions for Correct Use**

The twisted-pair cable should not exceed 10 m in length.

Open-collector Input

- External 24-V power supply without a current-limiting resistor (200 kpps maximum) (+24VCW: 1, -CW: 4, +24VCCW: 2, -CCW: 6)

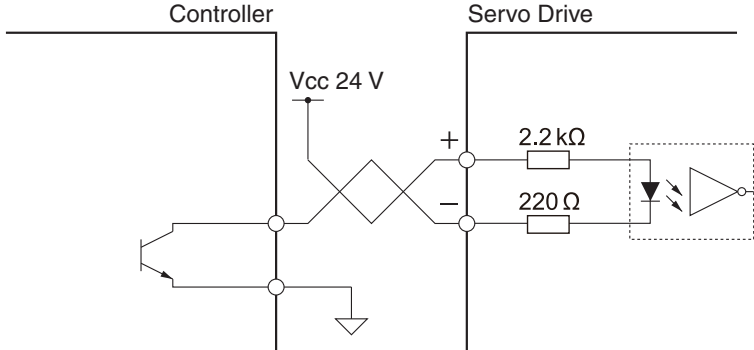

**Precautions for Correct Use**

The open-collector wiring should not exceed 2 m in length.

- External control power supply (200 kpps maximum) (+CW: 3, -CW: 4, +CCW: 5, -CCW: 6)

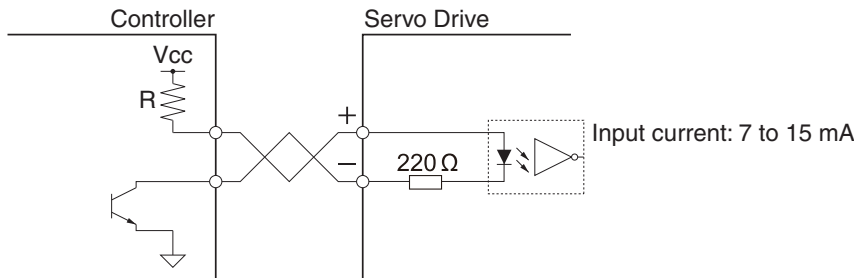

- Select a resistance R value so that the input current will be from 7 to 15 mA. Refer to the following table.

VCC	R
24 V	2 kΩ (1/2 W)
12 V	1 kΩ (1/2 W)

### 3-1 Servo Drive Specifications

#### ■ Sequence Input

External power supply:  
 12 VDC  $\pm 5\%$  to  
 24 VDC  $\pm 5\%$   
 Power supply capacity:  
 50 mA min. (per Unit)

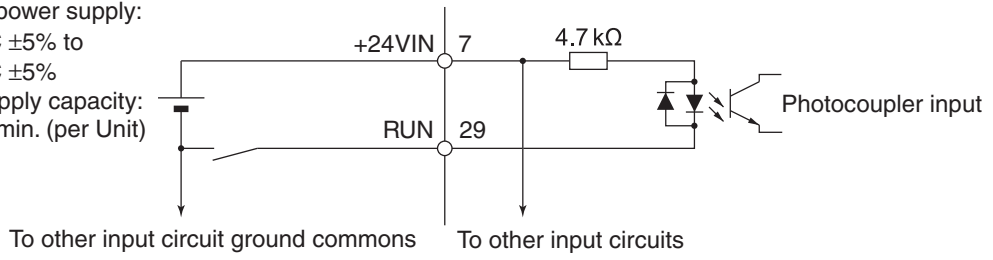

Signal Levels ON level: 10 V min.  
 OFF level: 3 V max.

#### ■ Sensor Input

##### Sensor ON Input **ABS**

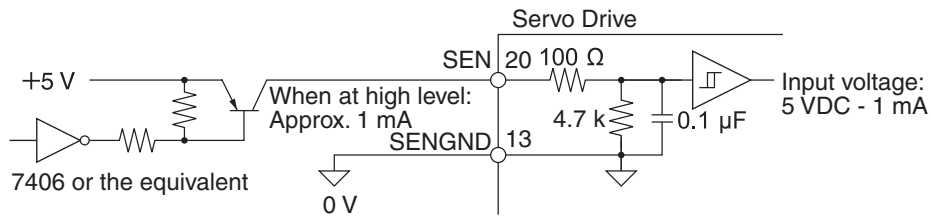

Signal Levels High level: 4 V min.  
 Low level: 0.8 V max.

#### Precautions for Correct Use

A PNP transistor is recommended.

### Control Input Details

Details on the input pins for the CN1 connector are described here.

■ **High-speed Photocoupler Inputs:**

**Reverse Pulse/Forward Pulse Inputs, Feed Pulse/Direction Signal Inputs, or 90° Phase Difference Signal Input**

- Pin 3: +Reverse Pulse Input (+CW), +Feed Pulse Input (+PULS), or +Phase A Input (+FA)
- Pin 4: -Reverse Pulse Input (-CW), -Feed Pulse Input (-PULS), or -Phase A Input (-FA)
- Pin 5: +Forward Pulse Input (+CCW), +Direction Signal (+SIGN), or +Phase B Input (+FB)
- Pin 6: -Forward Pulse Input (-CCW), -Direction Signal (-SIGN), or -Phase B Input (-FB)

**Functions**

- The functions of these signals depend on the settings of the Command Pulse Rotation Direction Switch (Pn41) and the Command Pulse Mode (Pn42).

Pn41 setting	Pn42 setting	Command pulse mode	Input pins	Servomotor forward command	Servomotor reverse command
0	0/2	90° phase difference signals (multiplier: 4)	3: +FA 4: -FA 5: +FB 6: -FB		
	1	Reverse pulses/forward pulses	3: +CW 4: -CW 5: +CCW 6: -CCW		
	3	Feed pulses/direction signal	3: +PULS 4: -PULS 5: +SIGN 6: -SIGN		

- If the Command Pulse Rotation Direction Switch (Pn41) is set to 1, the rotation direction will be reversed.
- If the photocoupler LED is turned ON, each signal will go high as shown above.

Specifications

### 3-1 Servo Drive Specifications

#### Command Pulse Timing for Photocoupler Inputs

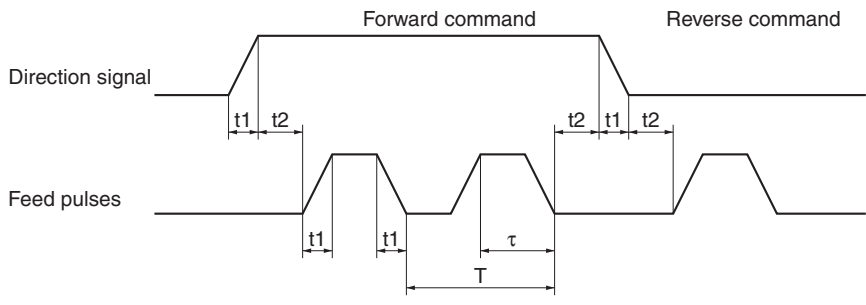
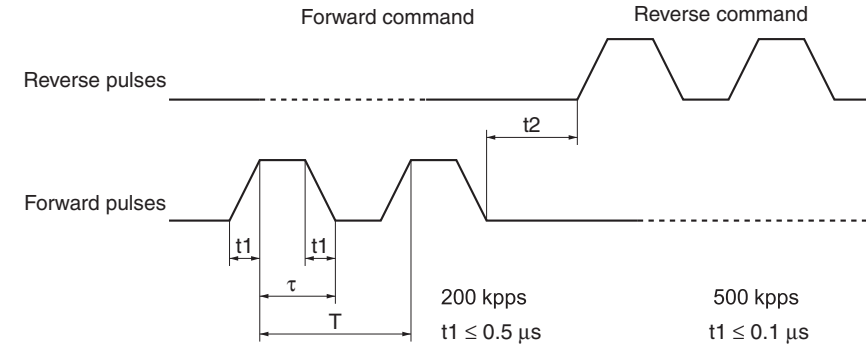
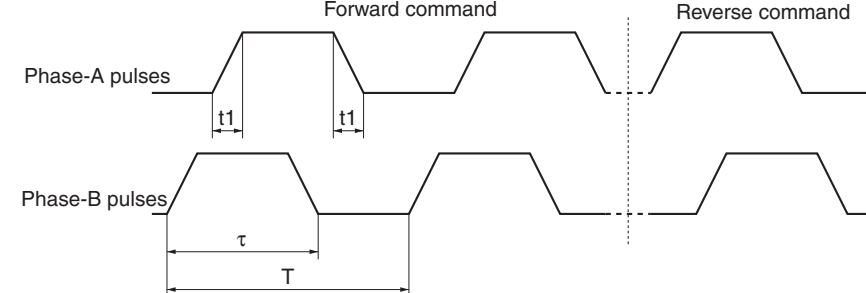
Command pulse mode	Timing													
<p>Feed pulses/direction signal</p> <p>Maximum Input Frequency Line driver: 500 kpps Open collector: 200 kpps</p>	 <table border="1" data-bbox="861 627 1340 840"> <thead> <tr> <th>200 kpps</th> <th>500 kpps</th> </tr> </thead> <tbody> <tr> <td><math>t1 \leq 0.5 \mu s</math></td> <td><math>t1 \leq 0.1 \mu s</math></td> </tr> <tr> <td><math>t2 &gt; 2.5 \mu s</math></td> <td><math>t2 &gt; 1.0 \mu s</math></td> </tr> <tr> <td><math>\tau \geq 2.5 \mu s</math></td> <td><math>\tau \geq 1.0 \mu s</math></td> </tr> <tr> <td><math>T \geq 5.0 \mu s</math></td> <td><math>T \geq 2.0 \mu s</math></td> </tr> <tr> <td><math>(\tau/T) \times 100 \leq 50 (\%)</math></td> <td><math>(\tau/T) \times 100 \leq 50 (\%)</math></td> </tr> </tbody> </table>		200 kpps	500 kpps	$t1 \leq 0.5 \mu s$	$t1 \leq 0.1 \mu s$	$t2 > 2.5 \mu s$	$t2 > 1.0 \mu s$	$\tau \geq 2.5 \mu s$	$\tau \geq 1.0 \mu s$	$T \geq 5.0 \mu s$	$T \geq 2.0 \mu s$	$(\tau/T) \times 100 \leq 50 (\%)$	$(\tau/T) \times 100 \leq 50 (\%)$
200 kpps	500 kpps													
$t1 \leq 0.5 \mu s$	$t1 \leq 0.1 \mu s$													
$t2 > 2.5 \mu s$	$t2 > 1.0 \mu s$													
$\tau \geq 2.5 \mu s$	$\tau \geq 1.0 \mu s$													
$T \geq 5.0 \mu s$	$T \geq 2.0 \mu s$													
$(\tau/T) \times 100 \leq 50 (\%)$	$(\tau/T) \times 100 \leq 50 (\%)$													
<p>Forward pulses/reverse pulses</p> <p>Maximum Input Frequency Line driver: 500 kpps Open collector: 200 kpps</p>	 <table border="1" data-bbox="861 1142 1340 1355"> <thead> <tr> <th>200 kpps</th> <th>500 kpps</th> </tr> </thead> <tbody> <tr> <td><math>t1 \leq 0.5 \mu s</math></td> <td><math>t1 \leq 0.1 \mu s</math></td> </tr> <tr> <td><math>t2 &gt; 2.5 \mu s</math></td> <td><math>t2 &gt; 1.0 \mu s</math></td> </tr> <tr> <td><math>\tau \geq 2.5 \mu s</math></td> <td><math>\tau \geq 1.0 \mu s</math></td> </tr> <tr> <td><math>T \geq 5.0 \mu s</math></td> <td><math>T \geq 2.0 \mu s</math></td> </tr> <tr> <td><math>(\tau/T) \times 100 \leq 50 (\%)</math></td> <td><math>(\tau/T) \times 100 \leq 50 (\%)</math></td> </tr> </tbody> </table>		200 kpps	500 kpps	$t1 \leq 0.5 \mu s$	$t1 \leq 0.1 \mu s$	$t2 > 2.5 \mu s$	$t2 > 1.0 \mu s$	$\tau \geq 2.5 \mu s$	$\tau \geq 1.0 \mu s$	$T \geq 5.0 \mu s$	$T \geq 2.0 \mu s$	$(\tau/T) \times 100 \leq 50 (\%)$	$(\tau/T) \times 100 \leq 50 (\%)$
200 kpps	500 kpps													
$t1 \leq 0.5 \mu s$	$t1 \leq 0.1 \mu s$													
$t2 > 2.5 \mu s$	$t2 > 1.0 \mu s$													
$\tau \geq 2.5 \mu s$	$\tau \geq 1.0 \mu s$													
$T \geq 5.0 \mu s$	$T \geq 2.0 \mu s$													
$(\tau/T) \times 100 \leq 50 (\%)$	$(\tau/T) \times 100 \leq 50 (\%)$													
<p>90° phase difference signals</p> <p>Maximum Input Frequency Line driver: 500 kpps Open collector: 200 kpps</p>	 <table border="1" data-bbox="861 1702 1340 1870"> <thead> <tr> <th>200 kpps</th> <th>500 kpps</th> </tr> </thead> <tbody> <tr> <td><math>t1 \leq 0.5 \mu s</math></td> <td><math>t1 \leq 0.1 \mu s</math></td> </tr> <tr> <td><math>\tau \geq 10 \mu s</math></td> <td><math>\tau \geq 4.0 \mu s</math></td> </tr> <tr> <td><math>T \geq 20 \mu s</math></td> <td><math>T \geq 8.0 \mu s</math></td> </tr> <tr> <td><math>(\tau/T) \times 100 \leq 50 (\%)</math></td> <td><math>(\tau/T) \times 100 \leq 50 (\%)</math></td> </tr> </tbody> </table>		200 kpps	500 kpps	$t1 \leq 0.5 \mu s$	$t1 \leq 0.1 \mu s$	$\tau \geq 10 \mu s$	$\tau \geq 4.0 \mu s$	$T \geq 20 \mu s$	$T \geq 8.0 \mu s$	$(\tau/T) \times 100 \leq 50 (\%)$	$(\tau/T) \times 100 \leq 50 (\%)$		
200 kpps	500 kpps													
$t1 \leq 0.5 \mu s$	$t1 \leq 0.1 \mu s$													
$\tau \geq 10 \mu s$	$\tau \geq 4.0 \mu s$													
$T \geq 20 \mu s$	$T \geq 8.0 \mu s$													
$(\tau/T) \times 100 \leq 50 (\%)$	$(\tau/T) \times 100 \leq 50 (\%)$													

3

Specifications

■ Line-receiver Inputs:

**Reverse Pulse/Forward Pulse Inputs, Feed Pulse/Direction Signal Inputs, or 90° Phase Difference Signal Inputs**

- Pin 44: +Reverse Pulse Input (+CW), +Feed Pulse Input (+PULS), or +Phase A Input (+FA)
- Pin 45: -Reverse Pulse Input (-CW), -Feed Pulse Input (-PULS), or -Phase A Input (-FA)
- Pin 46: +Forward Pulse Input (+CCW), +Direction Signal (+SIGN), or +Phase B Input (+FB)
- Pin 47: -Forward Pulse Input (-CCW), -Direction Signal (-SIGN), or -Phase B Input (-FB)

**Functions**

- The functions of these signals depend on the settings of the Command Pulse Rotation Direction Switch (Pn41) and the Command Pulse Mode (Pn42).

Pn41 setting	Pn42 setting	Command pulse mode	Input pins	Servomotor forward command	Servomotor reverse command
	0/2	90° phase difference signals (multiplier: 4)	44: +FA 45: -FA 46: +FB 47: -FB		
0	1	Reverse pulse/forward pulses	44: +CW 45: -CW 46: +CCW 47: -CCW		
	3	Feed pulses/direction signal	44: +PULS 45: -PULS 46: +SIGN 47: -SIGN		

- If the Command Pulse Rotation Direction Switch (Pn41) is set to 1, the rotation direction will be reversed.

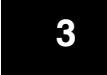

### 3-1 Servo Drive Specifications

#### Command Pulse Timing for Line-receiver Inputs

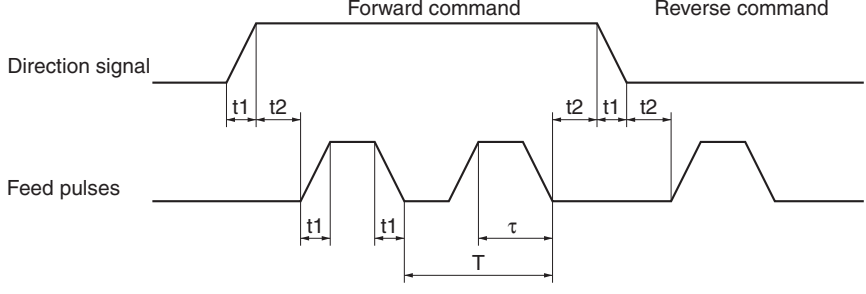
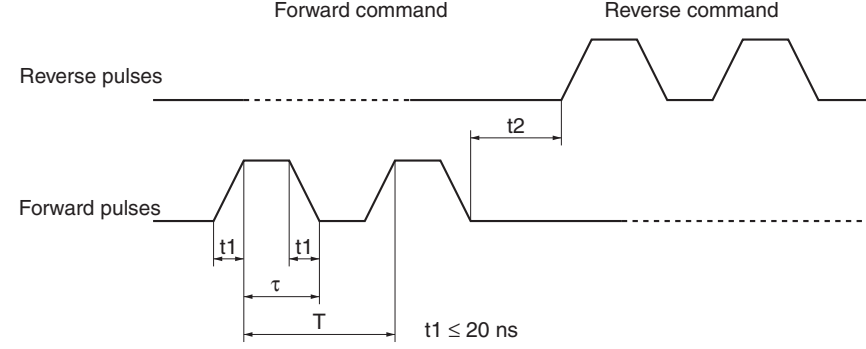
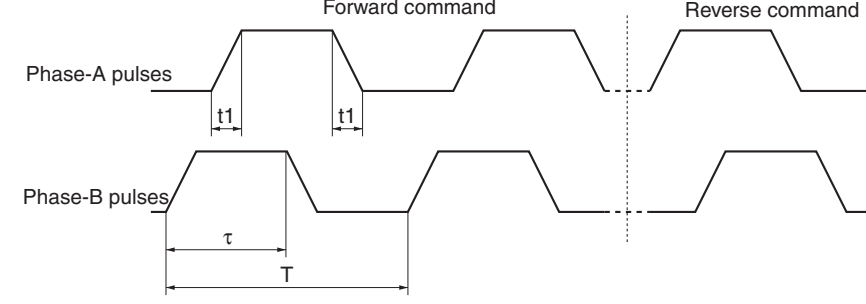
Command pulse mode	Timing
<p>Feed pulses/direction signal</p> <p>Maximum Input Frequency Line driver: 2 Mpps</p>	 <p style="text-align: center;"> <math>t1 \leq 20 \text{ ns}</math>  <math>t2 &gt; 500 \text{ ns}</math>  <math>\tau \geq 250 \text{ ns}</math>  <math>T \geq 500 \text{ ns}</math>  <math>(\tau/T) \times 100 \leq 50 (\%)</math> </p>
<p>Forward pulses/reverse pulses</p> <p>Maximum Input Frequency Line driver: 2 Mpps</p>	 <p style="text-align: center;"> <math>t1 \leq 20 \text{ ns}</math>  <math>t2 &gt; 500 \text{ ns}</math>  <math>\tau \geq 250 \text{ ns}</math>  <math>T \geq 500 \text{ ns}</math>  <math>(\tau/T) \times 100 \leq 50 (\%)</math> </p>
<p>90° phase difference signals</p> <p>Maximum Input Frequency Line driver: 2 Mpps</p>	 <p style="text-align: center;"> <math>t1 \leq 20 \text{ ns}</math>  <math>\tau \geq 4.0 \text{ ns}</math>  <math>T \geq 8.0 \text{ ns}</math>  <math>(\tau/T) \times 100 \leq 50 (\%)</math> </p>

3

Specifications

## ■ Reverse Drive Prohibit Input (NOT) and Forward Drive Prohibit Input (POT)

Pin 8: Reverse Drive Prohibit Input (NOT)  
Pin 9: Forward Drive Prohibit Input (POT)

### Functions

- These inputs are used to prohibit driving in the forward and reverse directions.
- If the Drive Prohibit Input Selection (Pn04) is set to 1, both inputs will be disabled.
- The Stop Selection for Drive Prohibition Input (Pn66) changes the operation when these inputs are enabled.

## ■ Speed Command Input (REF) or Torque Command Input (TREF1)

Pin 14: Speed Command Input (REF) or Torque Command Input (TREF1)  
Pin 15: Analog Input Ground (AGND)

### Functions

- Speed Control Mode  
Pin 14 is the Speed Command Input when the Control Mode Selection (Pn02) is set to 1 (Speed Control). Use the Speed Command Scale (Pn50) to set the rotation speed scale for the command input.
- Torque Control Mode  
Pin 14 is the Torque Command Input when the Control Mode Selection (Pn02) is set to 2 (Torque Control). The input gain, polarity, offset, and filters can be set for the torque command.

## ■ RUN Command Input (RUN)

Pin 29: RUN Command Input (RUN)

### Functions

- This input turns ON the power drive circuit for the main circuit of the Servo Drive. If this signal is not input (i.e., servo-OFF status), the Servomotor cannot operate.

## ■ Deviation Counter Reset Input (ECRST)

Pin 30: Deviation Counter Reset Input (ECRST)

### Functions

- Position Control Mode  
The value of the deviation counter will be reset when the deviation counter reset input turns ON. The condition for resetting is selected in the Deviation Counter Reset Condition Setting (Pn4E). The pulse width of the Deviation Counter Reset Signal must be at least 100  $\mu$ s.

### ■ Alarm Reset Input (RESET)

Pin 31: Alarm Reset Input (RESET)

#### Functions

- Pin 31 is the external reset signal for Servo Drive alarms. (The alarms are reset when this signal is input.)
- The alarm status is reset when RESET is connected to the 24-V power supply ground for +24VIN for 120 ms or longer.
- The deviation counter is also reset when alarms are reset.
- Eliminate the cause of the alarm before resuming operation. To prevent danger, turn OFF the RUN Command Input first, then input the alarm reset signal.

### ■ Control Mode Switch Input (TVSEL)

Pin 32: Control Mode Switch Input (TVSEL)

#### Functions

- If the Control Mode Selection (Pn02) is set to 3, 4, or 5, the control mode can be switched as given in the following table.

Pn02 setting	Mode 1	Mode 2
3	Position control	Speed control
4	Position control	Torque control
5	Speed control	Torque control

### ■ Pulse Prohibit Input (IPG) and Internally Set Speed Selection 1 (VSEL1)

Pin 33: Pulse Prohibit Input (IPG) / Internally Set Speed Selection 1 (VSEL1)

#### Functions

- Position Control Mode  
Pin 33 is the Pulse Prohibit Input.  
When the input is OFF, inputting command pulses will be disabled.  
The Pulse Prohibit Input can be disabled by setting the Command Pulse Prohibited Input (Pn43).
- Speed Control Mode  
Pin 33 is the Internally Set Speed Selection 1 (VSEL1).  
This input can be used together with the ECRST/VSEL2 and GESEL/VSEL3 inputs to select any of eight internally set speeds.
- Torque Control Mode  
This input is disabled.



### Control Output Circuits

#### Position Feedback Output

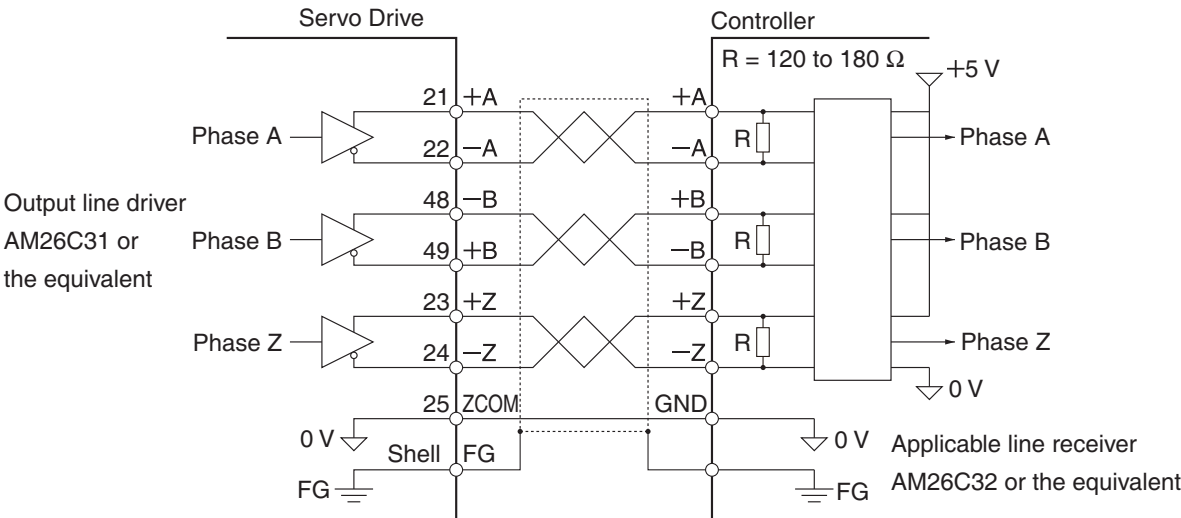

#### Phase-Z Output (Open-collector Output)

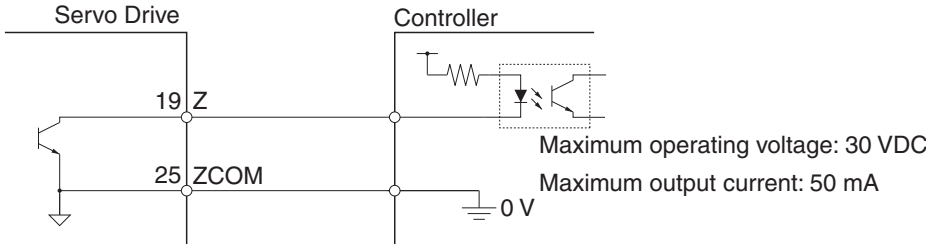

#### Sequence Output

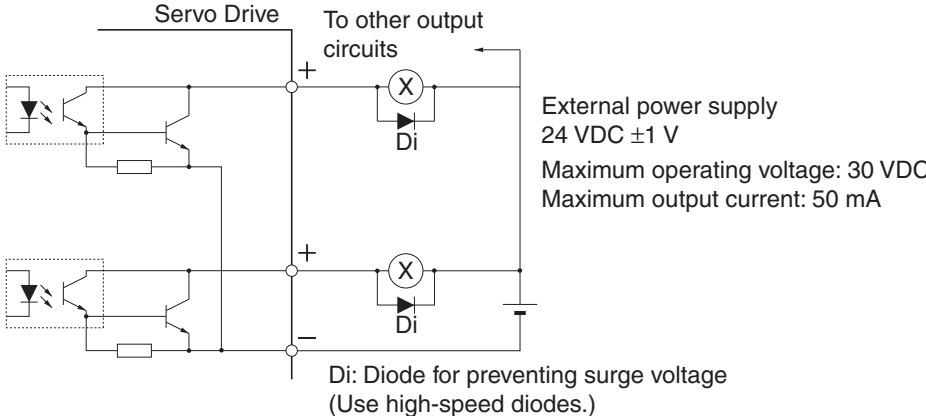

Specifications

## Control Output Details

### Control Output Sequence

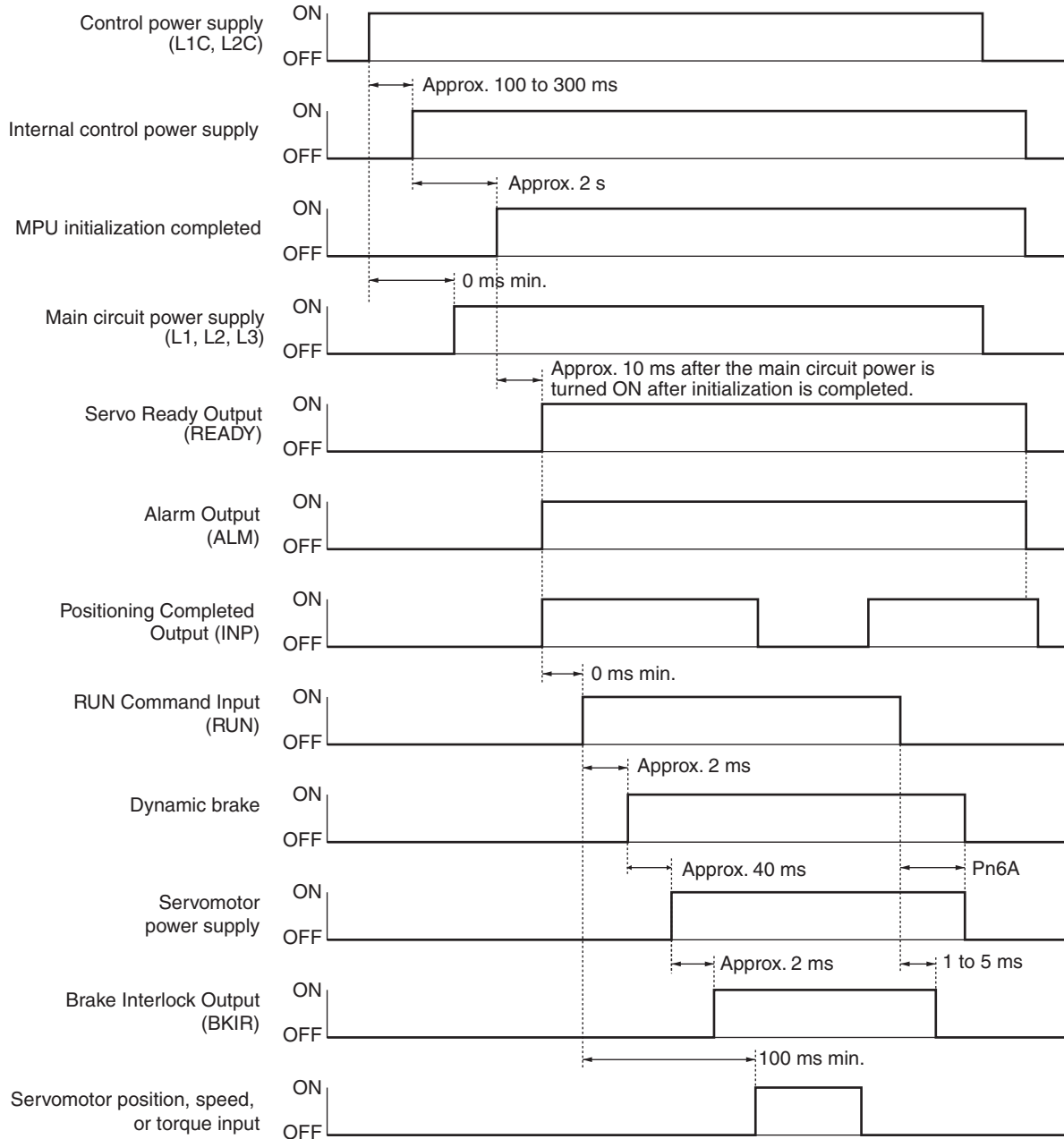

3 Specifications

Encoder Outputs (Phases A, B, and Z)

Pin 21: +A, 22: -A, 48: -B, 49: +B, 23: +Z, 24: -Z

Functions

- Pin 21 outputs the phase-A, phase-B, and phase-Z encoder signals for the Servomotor.
- The encoder outputs conform to the RS-422 communication method.
- The dividing ratio is set in the Encoder Divider Numerator Setting (Pn44) and the Encoder Divider Denominator Setting (Pn45).
- The logical relation of phase B to the phase-A pulse is set in the Encoder Output Direction Switch (Pn46).
- The ground for the output circuit line driver is connected to the signal ground (GND). It is not isolated.
- The maximum output frequency is 4 Mpps (after multiplying by 4). The output frequency equals the Servomotor encoder resolution  $\times$  (Pn44/Pn45)  $\times$  4  $\times$  Servomotor rotation speed (r/min)  $\div$  60
- The output phases are shown below. (They are the same for both incremental and absolute encoders.)

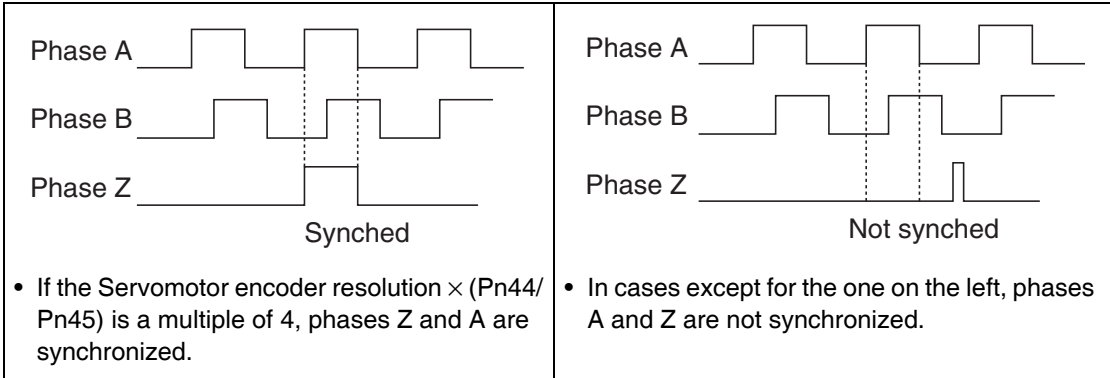

## 3-1 Servo Drive Specifications

---

### ■ Brake Interlock Output (BKIR)

Pin 11: Brake Interlock Output (BKIR)

#### Functions

- Pin 11 outputs an external brake timing signal according to the settings of the Brake Timing When Stopped (Pn6A) and Brake Timing During Operation (Pn6B).

### ■ Servo Ready Output (READY)

Pin 35: Servo Ready Output (READY)

#### Functions

- This output signal indicates that the Servo Drive is turned ON and ready to start operation.
- This output will turn ON if no errors occur after the main circuit power supply is turned ON.

### ■ Alarm Output (/ALM)

Pin 37: Alarm Output (/ALM)

#### Functions

- The alarm output is turned OFF when the Servo Drive detects an error.
- This output is OFF at power-ON, but turns ON when the Servo Drive's initial processing has been completed.

### ■ Positioning Completed Output (INP) or Servomotor Rotation Speed Detection Output (TGON)

Pin 39: Positioning Completed Output (INP) or Servomotor Rotation Speed Detection Output (TGON)

#### Functions

- Position Control Mode  
The INP signal turns ON when the number of accumulated pulses in the deviation counter is less than the Positioning Completion Range (Pn60). The output condition is set in the Positioning Completion Condition Setting (Pn63).
- Speed Control or Torque Control Mode  
The TGON signal turns ON when the speed of the Servomotor exceeds the setting of the Rotation Speed for Motor Rotation Detection (Pn62).

## Encoder Connector Specifications (CN2)

Pin No.	Symbol	Name	Function/Interface
1	E5V	Encoder power supply +5 V	Power supply output for the encoder 5.2 V, 180 mA
2	E0V	Encoder power supply GND	
3	BAT+	Battery +	Backup power supply output for the absolute encoder. 3.6 V, 100 $\mu$ A for operation during power interruption, 265 $\mu$ A for power interruption timer, and 3.6 $\mu$ A when power is supplied to Servo Drive
4	BAT-	Battery -	
5	PS+	Encoder +phase S input	Line-driver input (corresponding with the EIA RS-485 communications method)
6	PS-	Encoder -phaseS input	
Shell	FG	Shield ground	Cable shield ground

### Connectors for CN2 (6 Pins)

Name	Model	Manufacturer
Servo Drive Connector	53460-0629	Molex Japan Co.
Cable Connector	55100-0670	

### 3-1 Servo Drive Specifications

#### Communications Connector Specifications (CN3A)

Pin No.	Symbol	Name	Function/Interface
4	GND	Ground	---
7	B+	RS-485 communications data	Communications data interface between Servo Drives
8	A-		

#### Connector for CN3A (8 Pins)

Name	Model	Manufacturer
Connector	MD-S8000-10	J.S.T. Mfg. Co.

#### Parameter Unit Connector Specifications (CN3B)

Pin No.	Symbol	Name	Function/Interface
3	TXD	RS-232 send data	Send data output to the Parameter Unit or personal computer
4	GND	Ground	---
5	RXD	RS-232 receive data	Receive data input from the Parameter Unit or personal computer
7	B+	RS-485 communications data	Communications data interface between Servo Drives
8	A-		

#### Connector for CN3B (8 Pins)

Name	Model	Manufacturer
Connector	MD-S8000-10	J.S.T. Mfg. Co.

## 3-2 Servomotor Specifications

The following OMNUC G-Series AC Servomotors are available.

- 3,000-r/min Servomotors
- 3,000-r/min Flat Servomotors
- 2,000-r/min Servomotors
- 1,000-r/min Servomotors

There are various options available on the Servomotors, such as models with brakes or different shaft types. Select a Servomotor based on the mechanical system's load conditions and the installation environment.

### General Specifications

Item	3,000-r/min Servomotors		3,000-r/min Flat Servomotors	1,000-r/min Servomotors 2,000-r/min Servomotors	
	50 to 750 W	1 to 5 kW	100 to 400 W	900 W to 5 kW	6 to 7.5 kW
Ambient operating temperature and humidity	0 to 40°C, 85% RH max. (with no condensation)				
Ambient storage temperature and humidity	-20 to 65°C, 85% RH max. (with no condensation)	-20 to 80°C, 85% RH max. (with no condensation)			
Storage and operating atmosphere	No corrosive gases				
Vibration resistance *1	10 to 2,500 Hz and acceleration of 49 m/s <sup>2</sup> max. in the X, Y, and Z directions	10 to 2,500 Hz and acceleration of 24.5 m/s <sup>2</sup> max. in the X, Y, and Z directions	10 to 2,500 Hz and acceleration of 49 m/s <sup>2</sup> max. in the X, Y, and Z directions	10 to 2,500 Hz and acceleration of 24.5 m/s <sup>2</sup> max. in the X, Y, and Z directions	
Impact resistance	Acceleration of 98 m/s <sup>2</sup> max. 3 times each in the X, Y, and Z directions	Acceleration of 98 m/s <sup>2</sup> max. 3 times each in the X, Y, and Z directions	Acceleration of 98 m/s <sup>2</sup> max. 3 times each in the X, Y, and Z directions	Acceleration of 98 m/s <sup>2</sup> max. 2 times vertically	
Insulation resistance	20 MΩ min. at 500 VDC between the power terminals and FG terminal				
Dielectric strength	1,500 VAC (50 or 60 Hz) for 1 minute between the power terminals and FG terminal				
Operating position	All directions				
Insulation grade	Type B	Type F	Type B	Type F	
Structure	Totally enclosed, self-cooling				
Protective structure	IP65 (excluding the output shaft rotating section and lead wire ends)				
Vibration grade	V-15				
Mounting method	Flange-mounting				
International standards	EC Directives	Low-voltage Directive	IEC 60034-1/-5		
	UL standards		UL 1004		
	CSA standards		CSA 22.2 No.100		

\*1. The amplitude may be amplified by mechanical resonance. Do not exceed 80% of the specified value for extended periods of time.

**Note 1.** Do not use the cable when it is laying in oil or water.

**Note 2.** Do not expose the cable outlet or connections to stress due to bending or the weight of the cable itself.

## Characteristics

### ■ 3,000-r/min Servomotors

Model (R88M-)		100 VAC				
		G05030H	G10030L	G20030L	G40030L	
Item	Unit	G05030T	G10030S	G20030S	G40030S	
Rated output *1	W	50	100	200	400	
Rated torque *1	N·m	0.16	0.32	0.64	1.3	
Rated rotation speed	r/min	3000				
Max. momentary rotation speed	r/min	5000				
Max. momentary torque *1	N·m	0.45	0.93	1.78	3.6	
Rated current *1	A (rms)	1.1	1.7	2.5	4.6	
Max. momentary current *1	A (rms)	3.4	5.1	7.6	13.9	
Rotor inertia	kg·m <sup>2</sup> (GD <sup>2</sup> /4)	2.5 × 10 <sup>-6</sup>	5.1 × 10 <sup>-6</sup>	1.4 × 10 <sup>-5</sup>	2.6 × 10 <sup>-5</sup>	
Applicable load inertia	---	30 times the rotor inertia max. *2				
Torque constant *1	N·m/A	0.14	0.19	0.26	0.28	
Power rate *1	kW/s	10.4	20.1	30.3	62.5	
Mechanical time constant	ms	1.56	1.11	0.72	0.55	
Electrical time constant	ms	0.7	0.8	2.5	2.9	
Allowable radial load *3	N	68	68	245	245	
Allowable thrust load *3	N	58	58	98	98	
Weight	Without brake	kg	Approx. 0.3	Approx. 0.5	Approx. 0.8	Approx. 1.2
	With brake	kg	Approx. 0.5	Approx. 0.7	Approx. 1.3	Approx. 1.7
Radiation shield dimensions (material)		100 × 80 × t10 (Al)		130 × 120 × t12 (Al)		
Applicable Servo Drives (R88D-)		GTA5L	GT01L	GT02L	GT04L	
Brake specifications	Brake inertia	kg·m <sup>2</sup> (GD <sup>2</sup> /4)	2 × 10 <sup>-7</sup>	2 × 10 <sup>-7</sup>	1.8 × 10 <sup>-6</sup>	1.8 × 10 <sup>-6</sup>
	Excitation voltage *4	V	24 VDC ±5%			
	Power consumption (at 20°C)	W	7	7	9	9
	Current consumption (at 20°C)	A	0.3	0.3	0.36	0.36
	Static friction torque	N·m	0.29 min.	0.29 min.	1.27 min.	1.27 min.
	Attraction time *5	ms	35 max.	35 max.	50 max.	50 max.
	Release time *5	ms	20 max.	20 max.	15 max.	15 max.
	Backlash		±1°			
	Allowable work per braking	J	39.2	39.2	137	137
	Allowable total work	J	4.9 × 10 <sup>3</sup>	4.9 × 10 <sup>3</sup>	44.1 × 10 <sup>3</sup>	44.1 × 10 <sup>3</sup>
	Allowable angular acceleration	rad/s <sup>2</sup>	30,000 max. (Speed of 2,800 r/min or more must not be changed in less than 10 ms)			
	Brake life	---	10,000,000 operations			
	Rating	---	Continuous			
	Insulation grade	---	Type F			



Model (R88M-)		200 VAC					
		G05030H	G10030H	G20030H	G40030H	G75030H	
Item	Unit	G05030T	G10030T	G20030T	G40030T	G75030T	
Rated output t <sup>*1</sup>	W	50	100	200	400	750	
Rated torque <sup>*1</sup>	N·m	0.16	0.32	0.64	1.3	2.4	
Rated rotation speed	r/min	3000					
Max. momentary rotation speed	r/min	5000				4500	
Max. momentary torque <sup>*1</sup>	N·m	0.45	0.90	1.78	3.67	7.05	
Rated current <sup>*1</sup>	A (rms)	1.1	1.1	1.6	2.6	4	
Max. momentary current <sup>*1</sup>	A (rms)	3.4	3.4	4.9	7.9	12.1	
Rotor inertia	kg·m <sup>2</sup> (GD <sup>2</sup> /4)	2.5 × 10 <sup>-6</sup>	5.1 × 10 <sup>-6</sup>	1.4 × 10 <sup>-5</sup>	2.6 × 10 <sup>-5</sup>	8.7 × 10 <sup>-5</sup>	
Applicable load inertia	---	30 times the rotor inertia max. <sup>*2</sup>				20 times the rotor inertia max. <sup>*2</sup>	
Torque constant <sup>*1</sup>	N·m/A	0.14	0.19	0.41	0.51	0.64	
Power rate <sup>*1</sup>	kW/s	10.4	20.1	30.3	62.5	66	
Mechanical time constant	ms	1.56	1.1	0.71	0.52	0.45	
Electrical time constant	ms	0.7	0.79	2.6	3	4.6	
Allowable radial load <sup>*3</sup>	N	68	68	245	245	392	
Allowable thrust load <sup>*3</sup>	N	58	58	98	98	147	
Weight	Without brake	kg	Approx. 0.3	Approx. 0.5	Approx. 0.8	Approx. 1.2	Approx. 2.3
	With brake	kg	Approx. 0.5	Approx. 0.7	Approx. 1.3	Approx. 1.7	Approx. 3.1
Radiation shield dimensions (material)		100 × 80 × t10 (Al)		130 × 120 × t12 (Al)		170 × 160 × t12 (Al)	
Applicable Servo Drives (R88D-)		GT01H	GT01H	GT02H	GT04H	GT08H	
Brake specifications	Brake inertia	kg·m <sup>2</sup> (GD <sup>2</sup> /4)	2 × 10 <sup>-7</sup>	2 × 10 <sup>-7</sup>	1.8 × 10 <sup>-6</sup>	1.8 × 10 <sup>-6</sup>	7.5 × 10 <sup>-6</sup>
	Excitation voltage <sup>*4</sup>	V	24 VDC ±5%				
	Power consumption (at 20°C)	W	7	7	9	9	10
	Current consumption (at 20°C)	A	0.3	0.3	0.36	0.36	0.42
	Static friction torque	N·m	0.29min.	0.29 min.	1.27 min.	1.27 min.	2.45 min.
	Attraction time <sup>*5</sup>	ms	35 max.	35 max.	50 max.	50 max.	70 max.
	Release time <sup>*5</sup>	ms	20 max.	20 max.	15 max.	15 max.	20 max.
	Backlash		±1°				
	Allowable work per braking	J	39.2	39.2	137	137	196
	Allowable total work	J	4.9 × 10 <sup>3</sup>	4.9 × 10 <sup>3</sup>	44.1 × 10 <sup>3</sup>	44.1 × 10 <sup>3</sup>	147 × 10 <sup>3</sup>
	Allowable angular acceleration	rad/s <sup>2</sup>	30,000 max. (Speed of 2,800 r/min or more must not be changed in less than 10 ms)				
	Brake life	---	10,000,000 operations				
	Rating	---	Continuous				
	Insulation grade	---	Type F				

### 3-2 Servomotor Specifications

Model (R88M-)		200 VAC						
		G1K030T	G1K530T	G2K030T	G3K030T	G4K030T	G5K030T	
Item	Unit							
Rated output *1	W	1000	1500	2000	3000	4000	5000	
Rated torque *1	N·m	3.18	4.77	6.36	9.54	12.6	15.8	
Rated rotation speed	r/min	3000						
Max. momentary rotation speed	r/min	5000				4500		
Max. momentary torque *1	N·m	9.1	12.8	18.4	27.0	36.3	45.1	
Rated current *1	A (rms)	7.2	9.4	13	18.6	24.7	28.5	
Max. momentary current *1	A (rms)	21.4	28.5	40	57.1	75	85.7	
Rotor inertia	kg·m <sup>2</sup> (GD <sup>2</sup> /4)	1.69 × 10 <sup>-4</sup>	2.59 × 10 <sup>-4</sup>	3.46 × 10 <sup>-4</sup>	6.77 × 10 <sup>-4</sup>	1.27 × 10 <sup>-3</sup>	1.78 × 10 <sup>-3</sup>	
Applicable load inertia	---	15 times the rotor inertia max. *2						
Torque constant *1	N·m/A	0.44	0.51	0.48	0.51	0.51	0.57	
Power rate *1	kW/s	60	88	117	134	125	140	
Mechanical time constant	ms	0.78	0.54	0.53	0.46	0.51	0.46	
Electrical time constant	ms	6.7	10	10.8	20	20	20	
Allowable radial load *3	N	392	490	490	490	784	784	
Allowable thrust load *3	N	147	196	196	196	343	343	
Weight	Without brake	kg	Approx. 4.5	Approx. 5.1	Approx. 6.5	Approx. 9.3	Approx. 12.9	Approx. 17.3
	With brake	kg	Approx. 5.1	Approx. 6.5	Approx. 7.9	Approx. 11	Approx. 14.8	Approx. 19.2
Radiation shield dimensions (material)		170 × 160 × t12 (Al)	320 × 300 × t30 (Al)	320 × 300 × t20 (Al)	380 × 350 × t30 (Al)			
Applicable Servo Drives (R88D-)		GT15H	GT15H	GT20H	GT30H	GT50H	GT50H	
Brake specifications	Brake inertia	kg·m <sup>2</sup> (GD <sup>2</sup> /4)	2.5 × 10 <sup>-5</sup>	3.3 × 10 <sup>-5</sup>	3.3 × 10 <sup>-5</sup>	3.3 × 10 <sup>-5</sup>	1.35 × 10 <sup>-4</sup>	1.35 × 10 <sup>-4</sup>
	Excitation voltage *4	V	24 VDC ±10%					
	Power consumption (at 20°C)	W	18	19	19	19	22	22
	Current consumption (at 20°C)	A	0.74	0.81	0.81	0.81	0.9	0.9
	Static friction torque	N·m	4.9 min.	7.8 min.	7.8 min.	11.8 min.	16.1 min.	16.1 min.
	Attraction time *5	ms	50 max.	50 max.	50 max.	80 max.	110 max.	110 max.
	Release time *5	ms	15 max.	15 max.	15 max.	15 max.	50 max.	50 max.
	Backlash		±1°					
	Allowable work per braking	J	392	392	392	392	1470	1470
	Allowable total work	J	2.0 × 10 <sup>5</sup>	4.9 × 10 <sup>5</sup>	4.9 × 10 <sup>5</sup>	4.9 × 10 <sup>5</sup>	2.2 × 10 <sup>6</sup>	2.2 × 10 <sup>6</sup>
	Allowable angular acceleration	rad/s <sup>2</sup>	10,000 max. (Speed of 900 r/min or more must not be changed in less than 10 ms)					
	Brake life	---	10,000,000 operations					
	Rating	---	Continuous					
	Insulation grade	---	Type F					

- \*1. These are the values when the Servomotor is combined with a Servo Drive at room temperature (20°C, 65%). The maximum momentary torque indicates the standard value.
- \*2. Applicable Load Inertia:
  - The operable load inertia ratio (load inertia/rotor inertia) depends on the mechanical configuration and its rigidity. For a machine with high rigidity, operation is possible even with high load inertia. Select an appropriate motor and confirm that operation is possible.
  - If the dynamic brake is activated frequently with high load inertia, the dynamic brake resistor may burn. Do not repeatedly turn the Servomotor ON and OFF while the dynamic brake is enabled.
  - The dynamic brake is intended for emergency stop.  
If the dynamic brake is activated, provide an interval of 3 minutes or more before the next activation.
- \*3. The allowable radial and thrust loads are the values determined for a service life of 20,000 hours at normal operating temperatures. The allowable radial loads are applied as shown in the following diagram.

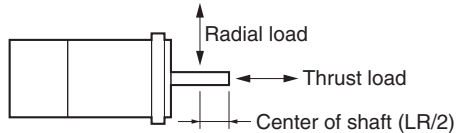

- \*4. This is an OFF brake. (It is reset when excitation voltage is applied).
- \*5. The operation time is the value (reference value) measured with a surge suppressor (CR50500 manufactured by Okaya Electric Industries Co., Ltd.).

### Torque-Rotational Speed Characteristics for 3,000-r/min Servomotors

- 3,000-r/min Servomotors with 100-VAC Power Input

The following graphs show the characteristics with a 3-m standard cable and a 100-VAC input.

#### • R88M-G05030H/T (50 W)

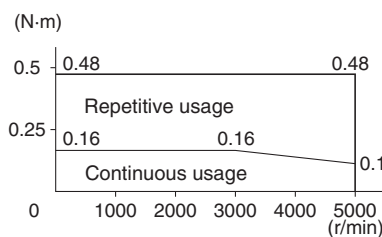

#### • R88M-G10030L/S (100 W)

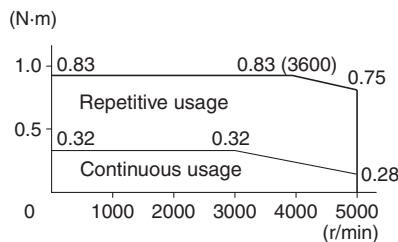

#### • R88M-G20030L/S (200 W)

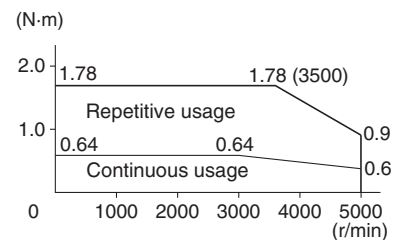

#### • R88M-G40030L/S (400 W)

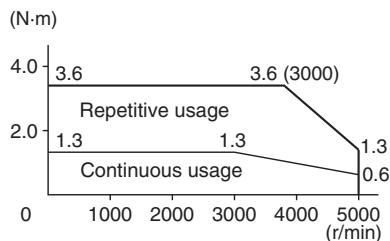

## 3-2 Servomotor Specifications

### • 3,000-r/min Servomotors with 200-VAC Power Input

The following graphs show the characteristics with a 3-m standard cable and a 200-VAC input.

#### • R88M-G05030H/T (50 W)

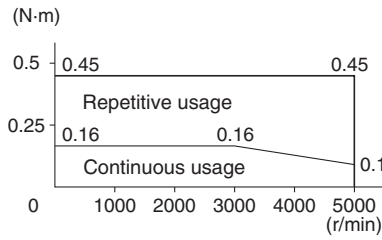

#### • R88M-G10030H/T (100 W)

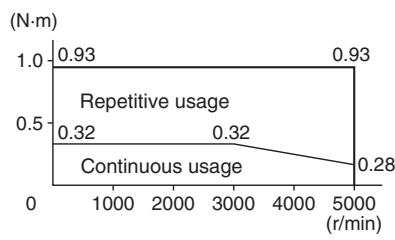

#### • R88M-G20030H/T (200 W)

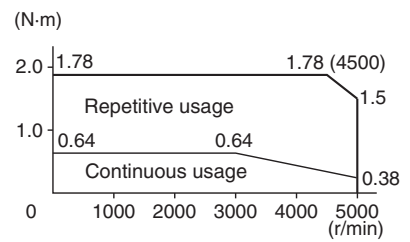

#### • R88M-G40030H/T (400 W)

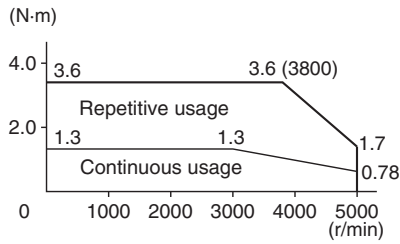

#### • R88M-G75030H/T (750 W)

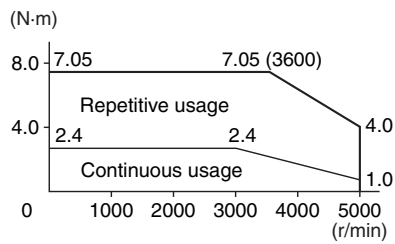

#### • R88M-G1K030T (1 kW)

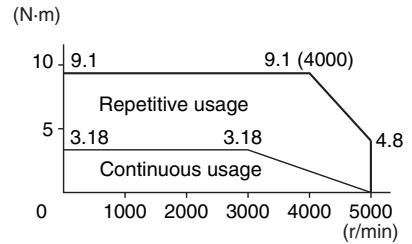

#### • R88M-G1K530T (1.5 kW)

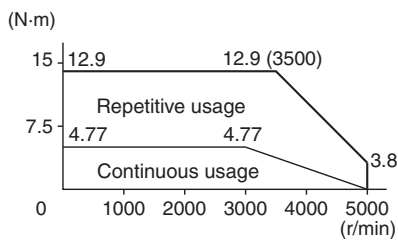

#### • R88M-G2K030T (2 kW)

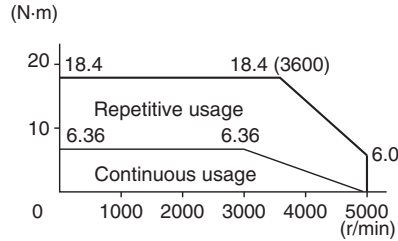

#### • R88M-G3K030T (3 kW)

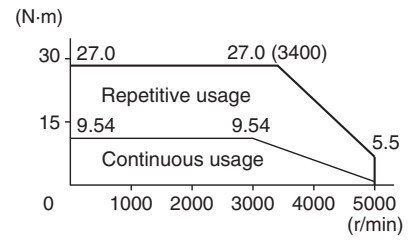

#### • R88M-G4K030T (4 kW)

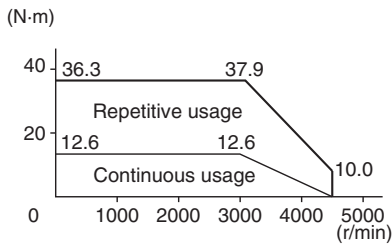

#### • R88M-G5K030T (5 kW)

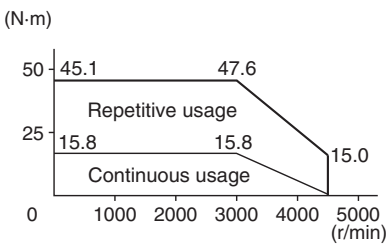

**Precautions for Correct Use**

Use the following Servomotors in the ranges shown in the graphs below. Using outside of these ranges may cause the Servomotor to generate heat, which could result in encoder malfunction.

◆ R88M-G05030H/T  
50 W (Without Oil Seal)

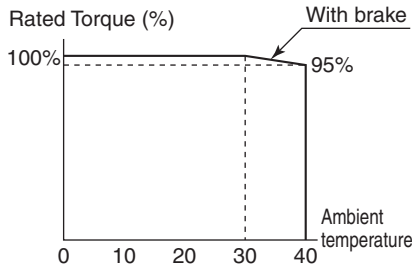

◆ R88M-G05030H/T  
50 W (With Oil Seal)

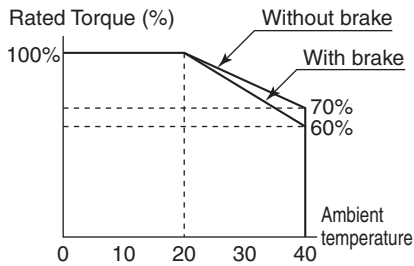

◆ R88M-G10030H/T  
100 W (Without Oil Seal)

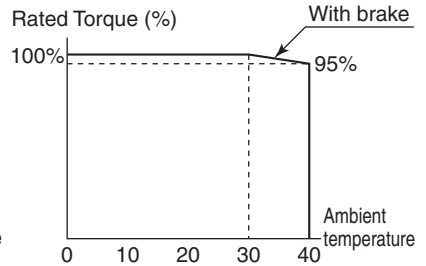

◆ R88M-G10030H/T  
100 W (With Oil Seal)

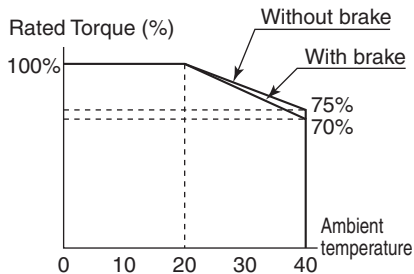

◆ R88M-G20030H/T  
200 W (With Oil Seal)

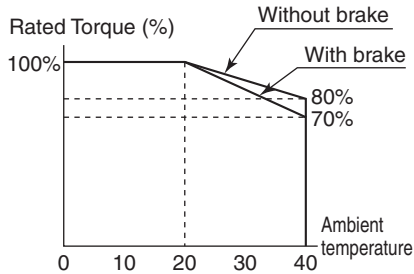

◆ R88M-G40030H/T  
400 W (Without Oil Seal)

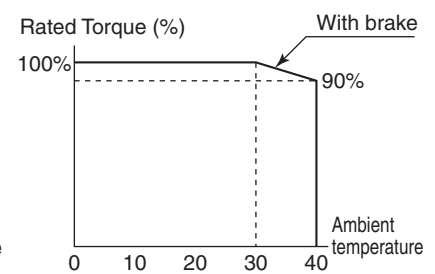

◆ R88M-G40030H/T  
400 W (With Oil Seal)

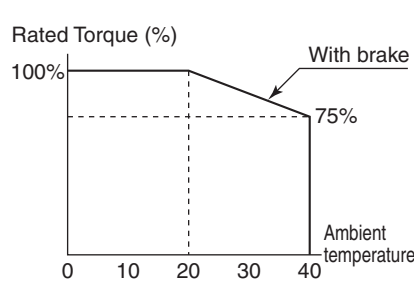

◆ R88M-G1K530T (1.5 kW)

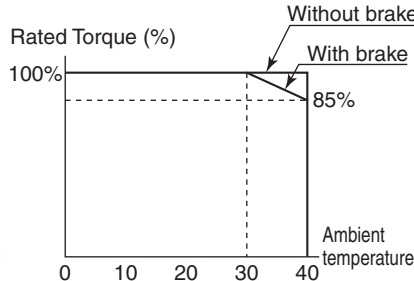

◆ R88M-G2K030T (2 kW)

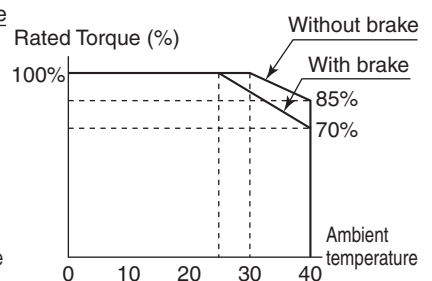

◆ R88M-G3K030T (3 kW)

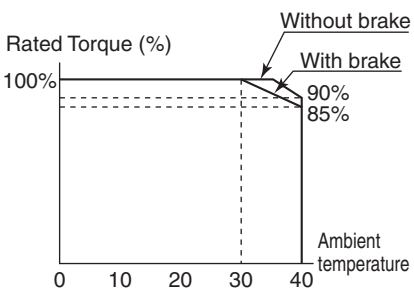

◆ R88M-G4K030T (4 kW)

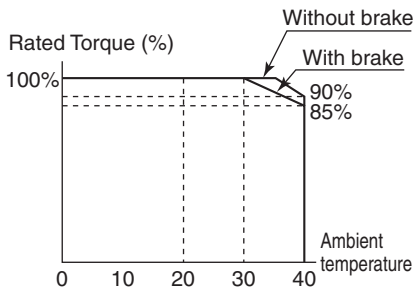

◆ R88M-G5K030T (5 kW)

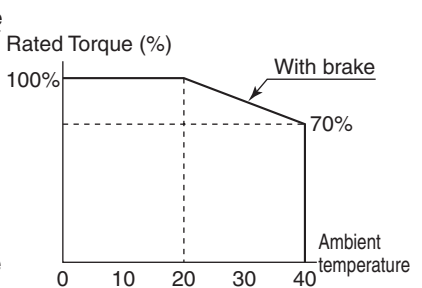

## 3-2 Servomotor Specifications

### ■ 3,000-r/min Flat Servomotors

Model (R88M-)		100 VAC			200 VAC			
		GP10030L	GP20030L	GP40030L	GP10030H	GP20030H	G40030H	
		GP10030S	GP20030S	GP40030S	GP10030T	GP20030T	G40030T	
Item	Unit							
Rated output *1	W	100	200	400	100	200	400	
Rated torque *1	N·m	0.32	0.64	1.3	0.32	0.64	1.3	
Rated rotation speed	r/min	3000			3000			
Max. momentary rotation speed	r/min	5000		4500	5000			
Max. momentary torque *1	N·m	0.84	1.8	3.6	0.86	1.8	3.65	
Rated current *1	A (rms)	1.6	2.5	4.4	1	1.6	2.5	
Max. momentary current *1	A (rms)	4.9	7.5	13.3	3.1	4.9	7.5	
Rotor inertia	kg·m <sup>2</sup> (GD <sup>2</sup> /4)	1.0 × 10 <sup>-5</sup>	3.5 × 10 <sup>-5</sup>	6.5 × 10 <sup>-5</sup>	1.0 × 10 <sup>-5</sup>	3.5 × 10 <sup>-5</sup>	6.4 × 10 <sup>-5</sup>	
Applicable load inertia	---	20 times the rotor inertia max.*2						
Torque constant *1	N·m/A	0.21	0.27	0.3	0.34	0.42	0.54	
Power rate *1	kW/s	10.2	11.7	26.0	10.2	11.5	25.5	
Mechanical time constant	ms	0.87	0.75	0.55	1.05	0.81	0.59	
Electrical time constant	ms	3.4	6.7	6.7	2.9	5.6	6.6	
Allowable radial load *3	N	68	245	245	68	245	245	
Allowable thrust load *3	N	58	98	98	58	98	98	
Weight	Without brake	kg	Approx. 0.7	Approx. 1.3	Approx. 1.8	Approx. 0.7	Approx. 1.3	Approx. 1.8
	With brake	kg	Approx. 0.9	Approx. 2	Approx. 2.5	Approx. 0.9	Approx. 2	Approx. 2.5
Radiation shield dimensions (material)		130 × 120 × t10 (Al)	170 × 160 × t12 (Al)		130 × 120 × t10 (Al)	170 × 160 × t12 (Al)		
Applicable Servo Drives (R88D-)		GT01L	GT02L	GT04L	GT01H	GT02H	GT04H	
Brake specifications	Brake inertia	kg·m <sup>2</sup> (GD <sup>2</sup> /4)	3 × 10 <sup>-6</sup>	9 × 10 <sup>-6</sup>	9 × 10 <sup>-6</sup>	3 × 10 <sup>-6</sup>	9 × 10 <sup>-6</sup>	9 × 10 <sup>-6</sup>
	Excitation voltage *4	V	24 VDC ±10%			24 VDC ±10%		
	Power consumption (at 20°C)	W	7	10	10	7	10	10
	Current consumption (at 20°C)	A	0.29	0.41	0.41	0.29	0.41	0.41
	Static friction torque	N·m	0.29 min.	1.27 min.	1.27 min.	0.29 min.	1.27 min.	1.27 min.
	Attraction time *5	ms	50 max.	60 max.	60 max.	50 max.	60 max.	60 max.
	Release time *5	ms	15 max.	15 max.	15 max.	15 max.	15 max.	15 max.
	Backlash		±1°			±1°		
	Allowable work per braking	J	137	196	196	137	196	196
	Allowable total work	J	44.1 × 10 <sup>3</sup>	147 × 10 <sup>3</sup>	147 × 10 <sup>3</sup>	44.1 × 10 <sup>3</sup>	147 × 10 <sup>3</sup>	147 × 10 <sup>3</sup>
	Allowable angular acceleration	rad/s <sup>2</sup>	10,000 max. (Speed of 900 r/min or more must not be changed in less than 10 ms)					
	Brake life	---	10,000,000 operations					
	Rating	---	Continuous			Continuous		
	Insulation grade	---	Type F			Type F		

- \*1. These are the values when the Servomotor is combined with a Servo Drive at room temperature (20°C, 65%). The maximum momentary torque indicates the standard value.
- \*2. Applicable Load Inertia:
  - The operable load inertia ratio (load inertia/rotor inertia) depends on the mechanical configuration and its rigidity. For a machine with high rigidity, operation is possible even with high load inertia. Select an appropriate motor and confirm that operation is possible.
  - If the dynamic brake is activated frequently with high load inertia, the dynamic brake resistor may burn. Do not repeatedly turn the Servomotor ON and OFF while the dynamic brake is enabled.
  - The dynamic brake is intended for emergency stop.  
If the dynamic brake is activated, provide an interval of 3 minutes or more before the next activation.
- \*3. The allowable radial and thrust loads are the values determined for a service life of 20,000 hours at normal operating temperatures. The allowable radial loads are applied as shown in the following diagram.

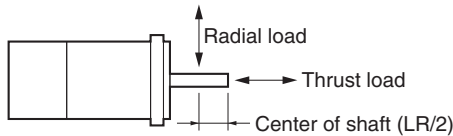

- \*4. This is an OFF brake. (It is reset when excitation voltage is applied).
- \*5. The operation time is the value (reference value) measured with a surge suppressor (CR50500 manufactured by Okaya Electric Industries Co., Ltd.).

### Torque-Rotational Speed Characteristics for 3,000-r/min Flat Servomotors

- 3,000-r/min Flat Servomotors with 100-VAC Power Input

The following graphs show the characteristics with a 3-m standard cable and a 100-VAC input.

- R88M-GP10030L/S (100 W)

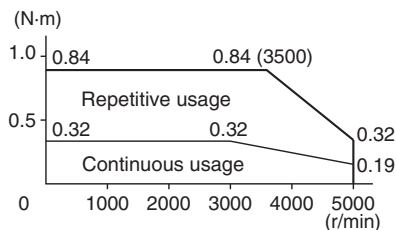

- R88M-GP20030L/S (200 W)

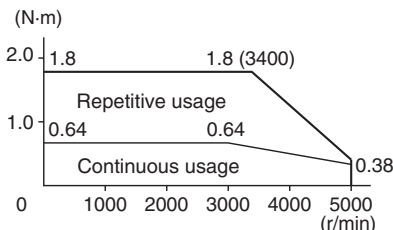

- R88M-GP40030L/S (400 W)

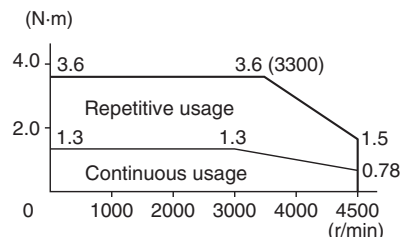

- 3,000-r/min Flat Servomotors with 200-VAC Power Input

The following graphs show the characteristics with a 3-m standard cable and a 200-VAC input.

- R88M-GP10030H/T (100 W)

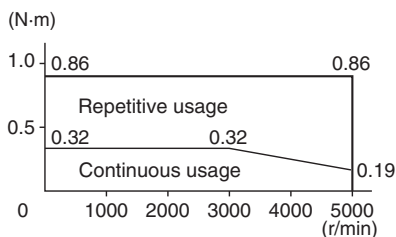

- R88M-GP20030H/T (200 W)

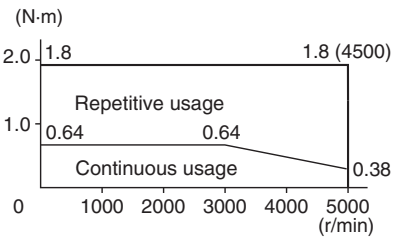

- R88M-GP40030H/T (400 W)

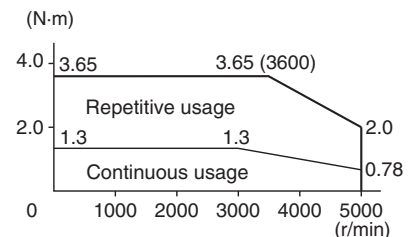

## 3-2 Servomotor Specifications

### ■ 2,000-r/min Servomotors

Item		Unit	200 VAC						G7K515T
			G1K020T	G1K520T	G2K020T	G3K020T	G4K020T	G5K020T	
Rated output *1		W	1000	1500	2000	3000	4000	5000	7500
Rated torque *1		N·m	4.8	7.15	9.54	14.3	18.8	23.8	48
Rated rotation speed		r/min	2000						1500
Max. momentary rotation speed		r/min	3000						2000
Max. momentary torque *1		N·m	13.5	19.6	26.5	41.2	54.9	70.6	111
Rated current *1		A (rms)	5.6	9.4	12.3	17.8	23.4	28	46.6
Max. momentary current *1		A (rms)	17.1	28.5	37.1	54.2	71.4	85.7	117.8
Rotor inertia		kg·m <sup>2</sup> (GD <sup>2</sup> /4)	$6.17 \times 10^{-4}$	$1.12 \times 10^{-3}$	$1.52 \times 10^{-3}$	$2.23 \times 10^{-3}$	$4.25 \times 10^{-3}$	$6.07 \times 10^{-3}$	$9.9 \times 10^{-3}$
Applicable load inertia		---	10 times the rotor inertia max. *2						
Torque constant *1		N·m/A	0.88	0.76	0.78	0.81	0.81	0.85	1.03
Power rate *1		kW/s	37.3	45.8	60	91.6	83.2	93.5	230
Mechanical time constant		ms	0.7	0.81	0.75	0.72	1	0.9	0.71
Electrical time constant		ms	18	19	21	20	24	32	34
Allowable radial load *3		N	490	490	490	784	784	784	1176
Allowable thrust load *3		N	196	196	196	343	343	343	490
Weight	Without brake	kg	Approx. 6.8	Approx. 8.5	Approx. 10.6	Approx. 14.6	Approx. 18.8	Approx. 25	Approx. 41
	With brake	kg	Approx. 8.7	Approx. 10.1	Approx. 12.5	Approx. 16.5	Approx. 21.3	Approx. 28.5	Approx. 45
Radiation shield dimensions (material)			275 × 260 × t15 (Al)			380 × 350 × t30 (Al)	470 × 440 × t30 (Al)		
Applicable Servo Drives (R88D-)			GT10H	GT15H	GT20H	GT30H	GT50H	GT50H	GT75H
Brake specifications	Brake inertia	kg·m <sup>2</sup> (GD <sup>2</sup> /4)	$1.35 \times 10^{-4}$				$4.25 \times 10^{-4}$	$4.7 \times 10^{-4}$	$4.7 \times 10^{-4}$
	Excitation voltage *4	V	24 VDC ±10%						
	Power consumption (at 20°C)	W	14	19	19	22	26	31	34
	Current consumption (at 20°C)	A	0.59	0.79	0.79	0.9	1.1	1.3	1.4
	Static friction torque	N·m	4.9 min.	13.7 min.	13.7 min.	16.1 min.	21.5 min.	24.5 min.	58.8 min.
	Attraction time *5	ms	80 max.	100 max.	100 max.	110 max.	90 max.	80 max.	150 max.
	Release time *5	ms	70 max.	50 max.	50 max.	50 max.	35 min.	25 min.	50 max.
	Backlash		±1°						
	Allowable work per braking	J	588	1176	1176	1170	1078	1372	1372
	Allowable total work	J	$7.8 \times 10^5$	$1.5 \times 10^6$	$1.5 \times 10^6$	$2.2 \times 10^6$	$2.5 \times 10^6$	$2.9 \times 10^6$	$2.9 \times 10^6$
	Allowable angular acceleration	rad/s <sup>2</sup>	10,000 max. (Speed of 900 r/min or more must not be changed in less than 10 ms)						
	Brake life	---	10,000,000 operations						
	Rating	---	Continuous						
Insulation grade	---	Type F							



- \*1. These are the values when the Servomotor is combined with a Servo Drive at room temperature (20°C, 65%). The maximum momentary torque indicates the standard value.
- \*2. Applicable Load Inertia:
  - The operable load inertia ratio (load inertia/rotor inertia) depends on the mechanical configuration and its rigidity. For a machine with high rigidity, operation is possible even with high load inertia. Select an appropriate motor and confirm that operation is possible.
  - If the dynamic brake is activated frequently with high load inertia, the dynamic brake resistor may burn. Do not repeatedly turn the Servomotor ON and OFF while the dynamic brake is enabled.
  - The dynamic brake is intended for emergency stop.  
If the dynamic brake is activated, provide an interval of 3 minutes or more before the next activation.
- \*3. The allowable radial and thrust loads are the values determined for a service life of 20,000 hours at normal operating temperatures. The allowable radial loads are applied as shown in the following diagram.

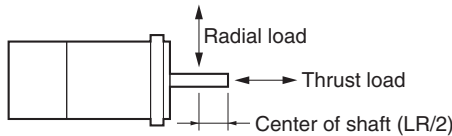

- \*4. This is an OFF brake. (It is reset when excitation voltage is applied).
- \*5. The operation time is the value (reference value) measured with a surge suppressor (CR50500 manufactured by Okaya Electric Industries Co., Ltd.).

### Torque-Rotational Speed Characteristics for 2,000-r/min Servomotors

• 2,000-r/min Servomotors with 200-VAC Power Input

The following graphs show the characteristics with a 3-m standard cable and a 200-VAC input.

• R88M-G1K020T (1 kW)

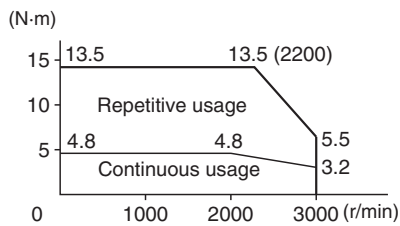

• R88M-G1K520T (1.5 kW)

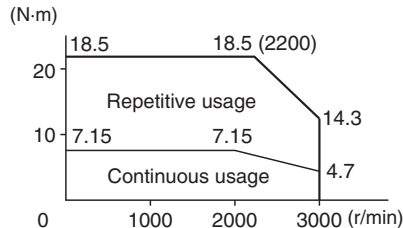

• R88M-G2K020T (2 kW)

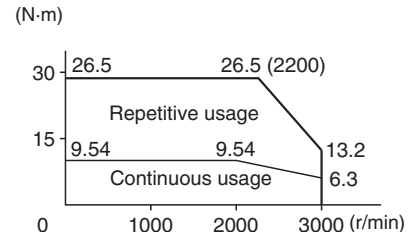

• R88M-G3K020T (3 kW)

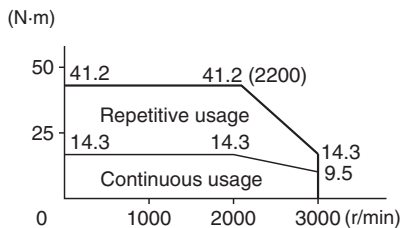

• R88M-G4K020T (4 kW)

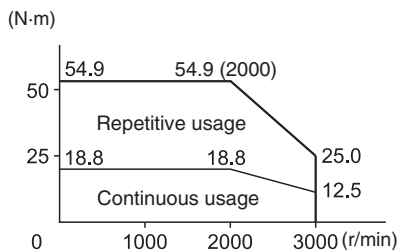

• R88M-G5K020T (5 kW)

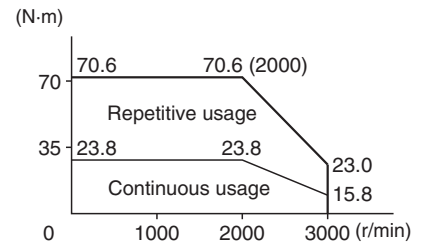

• R88M-G7K520T (7.5 kW)

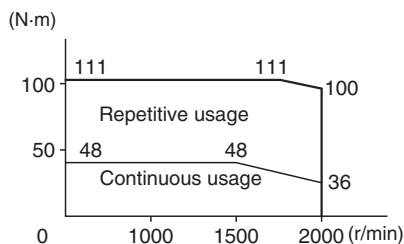

## 3-2 Servomotor Specifications

### ■ 1,000-r/min Servomotors

Model (R88M-)		200 VAC					
Item	Unit	G90010T	G2K010T	G3K010T	G4K510T	G6K010T	
Rated output *1	W	900	2000	3000	4500	6000	
Rated torque *1	N·m	8.62	19.1	28.4	42.9	57.2	
Rated rotation speed	r/min	1000					
Max. momentary rotation speed	r/min	2000					
Max. momentary torque *1	N·m	18.4	41.5	60	101	130	
Rated current *1	A (rms)	7.6	18.5	24	33	47	
Max. momentary current *1	A (rms)	17.1	44	57.1	84.2	121.4	
Rotor inertia	kg·m <sup>2</sup> (GD <sup>2</sup> /4)	1.12 × 10 <sup>-3</sup>	3.55 × 10 <sup>-3</sup>	5.57 × 10 <sup>-3</sup>	8.09 × 10 <sup>-3</sup>	9.9 × 10 <sup>-3</sup>	
Applicable load inertia	---	10 times the rotor inertia max. *2					
Torque constant *1	N·m/A	1.13	1	1.1	1.3	1.22	
Power rate *1	kW/s	66.3	103	145	228	331	
Mechanical time constant	ms	0.88	0.97	0.74	0.7	0.65	
Electrical time constant	ms	20	25	30	31	46.2	
Allowable radial load *3	N	686	1176	1470	1470	1764	
Allowable thrust load *3	N	196	490	490	490	588	
Weight	Without brake	kg	Approx. 8.5	Approx. 17.5	Approx. 25	Approx. 34	Approx. 41
	With brake	kg	Approx. 10	Approx. 21	Approx. 28.5	Approx. 39.5	Approx. 45
Radiation shield dimensions (material)		275 × 260 × t15 (Al)	470 × 440 × t30 (Al)				
Applicable Servo Drives (R88D-)		GT15H	GT30H	GT50H	GT50H	GT75H	
Brake specifications	Brake inertia	kg·m <sup>2</sup> (GD <sup>2</sup> /4)	1.35 × 10 <sup>-4</sup>	4.7 × 10 <sup>-4</sup>	4.7 × 10 <sup>-4</sup>	4.7 × 10 <sup>-4</sup>	4.7 × 10 <sup>-4</sup>
	Excitation voltage *4	V	24 VDC ±10%				
	Power consumption (at 20°C)	W	19	31	34	34	34
	Current consumption (at 20°C)	A	0.79	1.3	1.4	1.4	1.4
	Static friction torque	N·m	13.7 min.	24.5 min.	58.8 min.	58.8 min.	58.8 min.
	Attraction time *5	ms	100 max.	80 max.	150 max.	150 max.	150 max.
	Release time *5	ms	50 max.	25 max.	50 max.	50 max.	50 max.
	Backlash		±1°				
	Allowable work per braking	J	1176	1372	1372	1372	1372
	Allowable total work	J	1.6 × 10 <sup>6</sup>	2.9 × 10 <sup>6</sup>	2.9 × 10 <sup>6</sup>	2.9 × 10 <sup>6</sup>	2.9 × 10 <sup>6</sup>
	Allowable angular acceleration	rad/s <sup>2</sup>	10,000 max. (Speed of 900 r/min or more must not be changed in less than 10 ms)				
	Brake life	---	10,000,000 operations				
	Rating	---	Continuous				
	Insulation grade	---	Type F				

- \*1. These are the values when the Servomotor is combined with a Servo Drive at room temperature (20°C, 65%). The maximum momentary torque indicates the standard value.
- \*2. Applicable Load Inertia:
  - The operable load inertia ratio (load inertia/rotor inertia) depends on the mechanical configuration and its rigidity. For a machine with high rigidity, operation is possible even with high load inertia. Select an appropriate motor and confirm that operation is possible.
  - If the dynamic brake is activated frequently with high load inertia, the dynamic brake resistor may burn. Do not repeatedly turn the Servomotor ON and OFF while the dynamic brake is enabled.
  - The dynamic brake is intended for emergency stop.  
If the dynamic brake is activated, provide an interval of 3 minutes or more before the next activation.
- \*3. The allowable radial and thrust loads are the values determined for a service life of 20,000 hours at normal operating temperatures. The allowable radial loads are applied as shown in the following diagram.

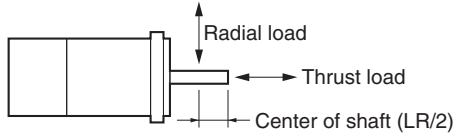

- \*4. This is an OFF brake. (It is reset when excitation voltage is applied).
- \*5. The operation time is the value (reference value) measured with a surge suppressor (CR50500 manufactured by Okaya Electric Industries Co., Ltd.).

#### Torque-Rotational Speed Characteristics for 1,000-r/min Servomotors

- 1,000-r/min Servomotors with 200-VAC Power Input

The following graphs show the characteristics with a 3-m standard cable and a 200-VAC input.

• R88M-G90010T (100 W)

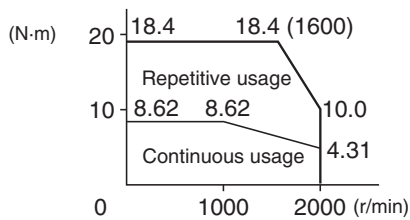

• R88M-G2K010T (2 kW)

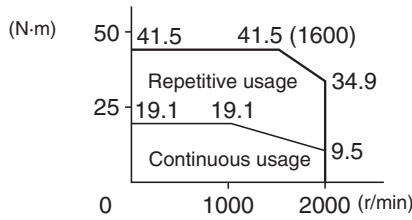

• R88M-G3K010T (3 kW)

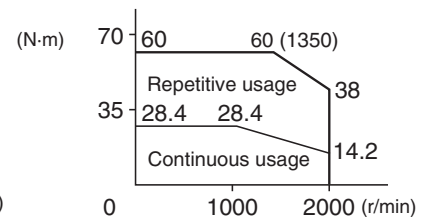

• R88M-G4K510T (4.5 kW)

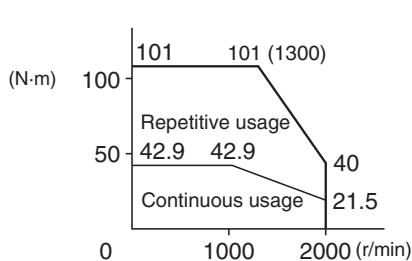

• R88M-G6K010T (6 kW)

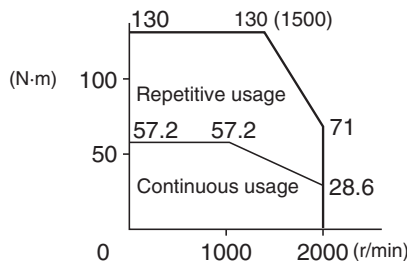

**Precautions for Correct Use**

Use the following Servomotors in the ranges shown in the graphs below. Using outside of these ranges may cause the Servomotor to generate heat, which could result in encoder malfunction.

- R88M-G4K510  
4.5 kW (Without Oil Seal)

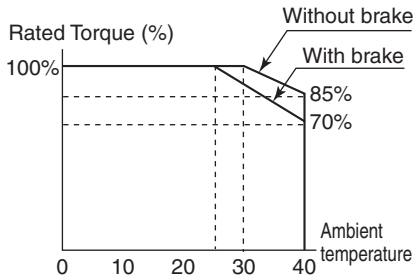

- R88M-G6K010T  
6 kW (With Oil Seal)

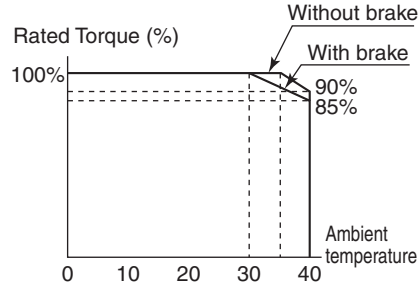

#### ■ Temperature Characteristics of the Servomotor and Mechanical System

- OMNUC G-Series AC Servomotors use rare earth magnets (neodymium-iron magnets). The temperature coefficient for these magnets is approximately  $-0.13\%/^{\circ}\text{C}$ . As the temperature drops, the Servomotor's maximum momentary torque increases, and as the temperature rises, the Servomotor's maximum momentary torque decreases.
- The maximum momentary torque rises by 4% at a normal temperature of  $20^{\circ}\text{C}$  compared to a temperature of  $-10^{\circ}\text{C}$ . Conversely, the maximum momentary torque decreases about 8% when the magnet warms up to  $80^{\circ}\text{C}$  from the normal temperature.
- Generally, when the temperature drops in a mechanical system, the friction torque and the load torque increase. For that reason, overloading may occur at low temperatures. In particular, in systems that use a Decelerator, the load torque at low temperatures may be nearly twice as much as the load torque at normal temperatures. Check whether overloading may occur at low temperature startup. Also check to see whether abnormal Servomotor overheating or alarms occur at high temperatures.
- An increase in load friction torque seemingly increases load inertia. Therefore, even if the Servo Drive gains are adjusted at a normal temperature, the Servomotor may not operate properly at low temperatures. Check to see whether there is optimal operation even at low temperatures.

## Encoder Specifications

### ■ Incremental Encoders

Item	Specifications
Encoder system	Optical encoder
No. of output pulses	Phases A and B: 2,500 pulses/rotation, Phase Z: 1 pulse/rotation
Power supply voltage	5 VDC $\pm$ 5%
Power supply current	180 mA (max.)
Output signals	+S, -S
Output interface	RS-485 compliance

### ■ Absolute Encoders

Item	Specifications
Encoder system	Optical encoder
	17 bits
No. of output pulses	Phases A and B: 32,768 pulses/rotation, Phase Z: 1 pulse/rotation
Maximum rotations	-32,768 to +32,767 rotations
Power supply voltage	5 VDC $\pm$ 5%
Power supply current	110 mA (max.)
Applicable battery voltage	3.6 VDC
Current consumption of battery	265 $\mu$ A for a maximum of 5 s right after power interruption 100 $\mu$ A for operation during power interruption 3.6 $\mu$ A when power is supplied to Servo Drive
Output signals	+S, -S
Output interface	RS-485 compliance

# 3-3 Decelerator Specifications

The following Decelerators are available for use with OMNUC G-Series Servomotors. Select a Decelerator matching the Servomotor capacity.

## Standard Models and Specifications

■ Backlash = 3' Max.

### Decelerators for 3,000-r/min Servomotors

Model		Rated rotation speed	Rated torque	Efficiency	Maximum momentary rotation speed	Maximum momentary torque	Decelerator inertia	Allowable radial load	Allowable thrust load	Weight	
		r/min	N·m	%	r/min	N·m	kg·m <sup>2</sup>	N	N	kg	
50 W	1/5	R88G-HPG11B05100B□	600	0.50	63	1000	1.42	$5.00 \times 10^{-7}$	135	538	0.29
	1/9	R88G-HPG11B09050B□	333	1.12	78	555	3.16	$3.00 \times 10^{-7}$	161	642	0.29
	1/21	R88G-HPG14A21100B□	143	2.18	65	238	6.13	$5.00 \times 10^{-6}$	340	1358	1.04
	1/33	R88G-HPG14A33050B□	91	3.73	71	151	10.5	$4.40 \times 10^{-6}$	389	1555	1.04
	1/45	R88G-HPG14A45050B□	67	5.09	71	111	14.3	$4.40 \times 10^{-6}$	427	1707	1.04
100 W	1/5	R88G-HPG11B05100B□	600	1.28	80	1000	3.6	$5.00 \times 10^{-7}$	135	538	0.29
	1/11	R88G-HPG14A11100B□	273	2.63	75	454	7.39	$6.00 \times 10^{-6}$	280	1119	1.04
	1/21	R88G-HPG14A21100B□	143	5.40	80	238	15.2	$5.00 \times 10^{-6}$	340	1358	1.04
	1/33	R88G-HPG20A33100B□	91	6.91	65	151	19.4	$6.50 \times 10^{-5}$	916	3226	2.4
	1/45	R88G-HPG20A45100B□	67	9.42	65	111	26.5	$6.50 \times 10^{-5}$	1006	3541	2.4
200 W	1/5	R88G-HPG14A05200B□	600	2.49	78	1000	6.93	$2.07 \times 10^{-5}$	221	883	1.02
	1/11	R88G-HPG14A11200B□	273	6.01	85	454	16.7	$1.93 \times 10^{-5}$	280	1119	1.09
	1/21	R88G-HPG20A21200B□	143	10.2	76	238	28.5	$4.90 \times 10^{-5}$	800	2817	2.9
	1/33	R88G-HPG20A33200B□	91	17.0	81	151	47.4	$4.50 \times 10^{-5}$	916	3226	2.9
	1/45	R88G-HPG20A45200B□	67	23.2	81	111	64.6	$4.50 \times 10^{-5}$	1006	3541	2.9

### 3-3 Decelerator Specifications

Model		Rated rotation speed	Rated torque	Efficiency	Maximum momentary rotation speed	Maximum momentary torque	Decelerator inertia	Allowable radial load	Allowable thrust load	Weight	
		r/min	N·m	%	r/min	N·m	kg·m <sup>2</sup>	N	N	kg	
400 W	1/5	R88G-HPG14A05400B□	600	5.66	87	1000	16.0 (15.7)	$2.07 \times 10^{-5}$	221	883	1.09
	1/11	R88G-HPG20A11400B□	273	11.73	82	454	33.1 (32.5)	$5.70 \times 10^{-5}$	659	2320	2.9
	1/21	R88G-HPG20A21400B□	143	23.56	86	238	66.5 (65.2)	$4.90 \times 10^{-5}$	800	2547	2.9
	1/33	R88G-HPG32A33400B□	91	34.79	81	151	98.2 (96.3)	$6.20 \times 10^{-5}$	1565	6240	7.5
	1/45	R88G-HPG32A45400B□	67	47.44	81	111	133.9 (131.4)	$6.10 \times 10^{-5}$	1718	6848	7.5
750 W	1/5	R88G-HPG20A05750B□	600	9.94	83	1000	29.2	$6.80 \times 10^{-5}$	520	1832	2.9
	1/11	R88G-HPG20A11750B□	273	23.23	88	454	68.1	$6.00 \times 10^{-5}$	659	2320	3.1
	1/21	R88G-HPG32A21750B□	143	42.34	84	238	124.3	$3.00 \times 10^{-4}$	1367	5448	7.8
	1/33	R88G-HPG32A33750B□	91	69.70	88	151	204.7	$2.70 \times 10^{-4}$	1565	6240	7.8
	1/45	R88G-HPG32A45750B□	67	95.04	88	111	279.2	$2.70 \times 10^{-4}$	1718	6848	7.8
1 kW	1/5	R88G-HPG32A051K0B□	600	11.5	72	1000	32.9	$3.90 \times 10^{-4}$	889	3542	7.3
	1/11	R88G-HPG32A111K0B□	273	28.9	83	454	82.6	$3.40 \times 10^{-4}$	1126	4488	7.8
	1/21	R88G-HPG32A211K0B□	143	58.1	87	238	166.1	$3.00 \times 10^{-4}$	1367	5488	7.8
	1/33	R88G-HPG32A331K0B□	91	94.3	90	151	270.0	$2.80 \times 10^{-4}$	1565	6240	7.8
	1/45	R88G-HPG50A451K0B□	67	124.2	87	100*1	355.4	$4.70 \times 10^{-4}$	4538	15694	19.0
1.5 kW	1/5	R88G-HPG32A052K0B□	600	19.1	80	1000	51.3	$3.90 \times 10^{-4}$	889	3542	7.4
	1/11	R88G-HPG32A112K0B□	273	45.7	87	454	122.5	$3.40 \times 10^{-4}$	1126	4488	7.9
	1/21	R88G-HPG32A211K5B□	143	90.1	90	238	241.9	$3.00 \times 10^{-4}$	1367	5448	7.9
	1/33	R88G-HPG50A332K0B□	91	141.5	90	136*1	379.7	$4.80 \times 10^{-4}$	4135	14300	19.0
	1/45	R88G-HPG50A451K5B□	67	192.9	90	100*1	517.8	$4.70 \times 10^{-4}$	4538	15694	19.0

### 3-3 Decelerator Specifications

Model		Rated rotation speed	Rated torque	Efficiency	Maximum momentary rotation speed	Maximum momentary torque	Decelerator inertia	Allowable radial load	Allowable thrust load	Weight	
		r/min	N·m	%	r/min	N·m	kg·m <sup>2</sup>	N	N	kg	
2 kW	1/5	R88G-HPG32A052K0B□	600	26.7	84	1000	77.4	$3.90 \times 10^{-4}$	889	3542	7.4
	1/11	R88G-HPG32A112K0B□	273	62.4	89	454	180.7	$3.40 \times 10^{-4}$	1126	4488	7.9
	1/21	R88G-HPG50A212K0B□	143	118.9	89	214*1	343.9	$5.80 \times 10^{-4}$	3611	12486	19.0
	1/33	R88G-HPG50A332K0B□	91	191.8	91	136*1	555.0	$4.80 \times 10^{-4}$	4135	14300	19.0
3 kW	1/5	R88G-HPG32A053K0B□	600	42.0	88	1000	118.9	$3.80 \times 10^{-4}$	889	3542	7.3
	1/11	R88G-HPG50A113K0B□	273	92.3	88	409*1	261.4	$7.70 \times 10^{-4}$	2974	10285	19.0
	1/21	R88G-HPG50A213K0B□	143	183.0	91	214*1	517.7	$5.80 \times 10^{-4}$	3611	12486	19.0
4 kW	1/5	R88G-HPG32A054K0B□	600	53.9	90	900*1	163.4	$3.80 \times 10^{-4}$	889	3542	7.9
	1/11	R88G-HPG50A115K0B□	273	124.6	90	409*1	359.0	$8.80 \times 10^{-4}$	2974	10285	19.1
5 kW	1/5	R88G-HPG50A055K0B□	600	69.3	88	900*1	197.8	$1.20 \times 10^{-3}$	2347	8118	17.7
	1/11	R88G-HPG50A115K0B□	273	158.4	91	409*1	451.9	$8.80 \times 10^{-4}$	2974	10285	19.1

\*1. Keep the maximum Servomotor rotation speed at 4,500 r/min or less.

\*2. If a cold start is used for the R88G-HPG11B05100B(J) when using a 50-W Servomotor, the efficiency will be reduced slightly. (The is because the viscosity of the lubricant in the Decelerator will increase if the Decelerator is cold, such as when starting after stopping for a period of time. If operation is continued until the temperature of the Decelerator increases, the viscosity of the lubricant will decrease and the efficiency will increase.)

**Note 1.** The values inside parentheses ( ) are for 100-V Servomotors.

**Note 2.** The Decelerator inertia is the Servomotor shaft conversion value.

**Note 3.** The protective structure for Servomotors with Decelerators satisfies IP44.

**Note 4.** The allowable radial load is the value at the T/2 position.

**Note 5.** The standard models have a straight shaft. Models with a key and tap are indicated with “J” at the end of the model number (the suffix in the box).



#### Decelerators for 2,000-r/min Servomotors

Model		Rated rotation speed	Rated torque	Efficiency	Maximum momentary rotation speed	Maximum momentary torque	Decelerator inertia	Allowable radial load	Allowable thrust load	Weight	
		r/min	N·m	%	r/min	N·m	kg·m <sup>2</sup>	N	N	kg	
1 kW	1/5	R88G-HPG32A053K0B□	400	20.4	85	600	57.4	$3.80 \times 10^{-4}$	889	3542	7.3
	1/11	R88G-HPG32A112K0SB□	182	47.3	90	273	133.1	$3.40 \times 10^{-4}$	1126	4488	7.8
	1/21	R88G-HPG32A211K0SB□	95	92.3	92	143	259.7	$2.90 \times 10^{-4}$	1367	5448	7.8
	1/33	R88G-HPG50A332K0SB□	60	144.9	92	91	407.6	$4.70 \times 10^{-4}$	4135	14300	19.0
	1/45	R88G-HPG50A451K0SB□	44	197.7	92	67	555.9	$4.70 \times 10^{-4}$	4538	15694	19.0
1.5 kW	1/5	R88G-HPG32A053K0B□	400	31.7	89	600	86.8	$3.80 \times 10^{-4}$	889	3542	7.3
	1/11	R88G-HPG32A112K0SB□	182	72.1	92	273	197.7	$3.40 \times 10^{-4}$	1126	4488	7.8
	1/21	R88G-HPG50A213K0B□	95	137.5	92	143	377.0	$5.80 \times 10^{-4}$	3611	12486	19.0
	1/33	R88G-HPG50A332K0SB□	60	219.4	93	91	601.5	$4.70 \times 10^{-4}$	4135	14300	19.0
2 kW	1/5	R88G-HPG32A053K0B□	400	43.2	91	600	119.9	$3.80 \times 10^{-4}$	889	3542	7.3
	1/11	R88G-HPG32A112K0SB□	182	97.4	93	273	270.5	$3.40 \times 10^{-4}$	1126	4488	7.8
	1/21	R88G-HPG50A213K0B□	95	185.6	93	143	515.9	$5.80 \times 10^{-4}$	3611	12486	19.0
	1/33	R88G-HPG50A332K0SB□	60	270.0*1	93	91	815.0	$4.70 \times 10^{-4}$	4135	14300	19.0

\*1. This is the allowable rated output torque for the decelerator only. Do not exceed this value.

### 3-3 Decelerator Specifications

Model		Rated rotation speed	Rated torque	Efficiency	Maximum momentary rotation speed	Maximum momentary torque	Decelerator inertia	Allowable radial load	Allowable thrust load	Weight	
		r/min	N·m	%	r/min	N·m	kg·m <sup>2</sup>	N	N	kg	
3 kW	1/5	R88G-HPG32A054K0B□	400	66.0	92	600	190.1	$3.80 \times 10^{-4}$	889	3542	7.9
	1/11	R88G-HPG50A115K0B□	182	145.2	92	273	418.3	$8.80 \times 10^{-4}$	2974	10285	19.1
	1/21	R88G-HPG50A213K0SB□	95	260.0*1	93	143	806.4	$6.90 \times 10^{-4}$	3611	12486	19.1
	1/25	R88G-HPG65A253K0SB□	80	322.9	90	120	930.1	$3.00 \times 10^{-3}$	7846	28654	52.0
4 kW	1/5	R88G-HPG50A054K0SB□	400	85.8	91	600	250.3	$1.20 \times 10^{-3}$	2347	8118	18.6
	1/11	R88G-HPG50A114K0SB□	182	192.7	93	273	562.8	$8.70 \times 10^{-4}$	2974	10285	20.1
	1/20	R88G-HPG65A204K0SB□	100	342.2	91	150	999.2	$3.28 \times 10^{-3}$	7338	26799	52.0
	1/25	R88G-HPG65A254K0SB□	80	430.9	92	120	1258.6	$3.24 \times 10^{-3}$	7846	28654	52.0
5 kW	1/5	R88G-HPG50A055K0SB□	400	109.8	92	600	325.5	$1.10 \times 10^{-3}$	2347	8118	22.0
	1/11	R88G-HPG50A115K0SB□	182	200.0*1	93	273	723.8	$8.40 \times 10^{-4}$	2974	10285	23.5
	1/20	R88G-HPG65A205K0SB□	100	438.2	92	150	1300.5	$2.85 \times 10^{-3}$	7338	26799	55.4
	1/25	R88G-HPG65A255K0SB□	80	550.9	93	120	1634.4	$2.81 \times 10^{-3}$	7846	28654	55.4
7.5 kW	1/5	R88G-HPG65A057K5SB□	300	221.1	92	400	511.2	$2.07 \times 10^{-2}$	4841	17681	48.0
	1/12	R88G-HPG65A127K5SB□	125	540.8	94	166	1250.7	$2.02 \times 10^{-2}$	6295	22991	52.0

\*1. This is the allowable rated output torque for the decelerator only. Do not exceed this value.

**Note 1.** The Decelerator inertia is the Servomotor shaft conversion value.

**Note 2.** The protective structure for Servomotors with Decelerators satisfies IP44.

**Note 3.** The allowable radial load is the value at the T/2 position.

**Note 4.** The standard models have a straight shaft. Models with a key and tap are indicated with “J” at the end of the model number (the suffix in the box).

## Decelerators for 1,000-r/min Servomotors

Model		Rated rotation speed	Rated torque	Efficiency	Maximum momentary rotation speed	Maximum momentary torque	Decelerator inertia	Allowable radial load	Allowable thrust load	Weight	
		r/min	N·m	%	r/min	N·m	kg·m <sup>2</sup>	N	N	kg	
900 W	1/5	R88G-HPG32A05900TB□	200	39.9	93	400	85.2	$3.80 \times 10^{-4}$	889	3542	7.9
	1/11	R88G-HPG32A11900TB□	90	89.0	94	182	190.1	$3.40 \times 10^{-4}$	1126	4488	8.4
	1/21	R88G-HPG50A21900TB□	47	169.8	94	95	362.4	$7.00 \times 10^{-4}$	3611	12486	19.1
	1/33	R88G-HPG50A33900TB□	30	268.5	94	60	573.2	$5.90 \times 10^{-4}$	4135	14300	19.1
2 kW	1/5	R88G-HPG32A052K0TB□	200	90.2	95	400	196.1	$4.90 \times 10^{-4}$	889	3542	8.9
	1/11	R88G-HPG50A112K0TB□	90	198.4	94	182	430.9	$8.40 \times 10^{-4}$	2974	10285	20.1
	1/21	R88G-HPG50A212K0TB□	47	320.0*1	95	95	786.8	$6.50 \times 10^{-4}$	3611	12486	20.1
	1/25	R88G-HPG65A255K0SB□	40	446.7	94	80	971.1	$2.81 \times 10^{-3}$	7846	28654	55.4
3 kW	1/5	R88G-HPG50A055K0SB□	200	133.9	94	400	282.9	$1.10 \times 10^{-3}$	2347	8118	22.0
	1/11	R88G-HPG50A115K0SB□	90	246.0*1	95	182	684.0	$8.40 \times 10^{-3}$	2974	10285	23.5
	1/20	R88G-HPG65A205K0SB□	50	534.7	94	100	1129.2	$2.85 \times 10^{-3}$	7338	26799	55.4
	1/25	R88G-HPG65A255K0SB□	40	669.9	94	80	1411.5	$2.81 \times 10^{-3}$	7846	28654	55.4
4.5 kW	1/5	R88G-HPG50A054K5TB□	200	203.5	95	400	479.2	$1.20 \times 10^{-3}$	2347	8118	22.0
	1/12	R88G-HPG65A127K5SB□	83	485.6	94	166	1142.9	$2.02 \times 10^{-2}$	6295	22991	52.0
	1/20	R88G-HPG65A204K5TB□	50	813.1	95	100	1915.0	$1.92 \times 10^{-2}$	7338	26799	52.0
6 kW	1/5	R88G-HPG65A057K5SB□	200	268.1	94	400	609.7	$2.07 \times 10^{-2}$	4841	17681	48.0
	1/12	R88G-HPG65A127K5SB□	83	650.3	95	166	1477.3	$2.02 \times 10^{-2}$	6295	22991	52.0

\*1. This is the allowable rated output torque for the decelerator only. Do not exceed this value.

**Note 1.** The Decelerator inertia is the Servomotor shaft conversion value.

**Note 2.** The protective structure for Servomotors with Decelerators satisfies IP44.

**Note 3.** The allowable radial load is the value at the T/2 position.

**Note 4.** The standard models have a straight shaft. Models with a key and tap are indicated with “J” at the end of the model number (the suffix in the box).

### 3-3 Decelerator Specifications

#### Decelerators for 3,000-r/min Flat Servomotors

Model		Rated rotation speed	Rated torque	Efficiency	Maximum momentary rotation speed	Maximum momentary torque	Decelerator inertia	Allowable radial load	Allowable thrust load	Weight	
		r/min	N·m	%	r/min	N·m	kg·m <sup>2</sup>	N	N	kg	
100 W	1/5	R88G-HPG11B05100PB□	600	1.28	80	1000	3.44 (3.36)	$5.00 \times 10^{-7}$	135	538	0.34
	1/11	R88G-HPG14A11100PB□	273	2.63	75	454	7.06 (6.89)	$6.00 \times 10^{-6}$	280	1119	1.04
	1/21	R88G-HPG14A21100PB□	143	5.40	80	238	14.5 (14.2)	$5.00 \times 10^{-6}$	340	1358	1.04
	1/33	R88G-HPG20A33100PB□	91	6.91	65	151	18.6 (18.1)	$4.50 \times 10^{-5}$	916	3226	2.9
	1/45	R88G-HPG20A45100PB□	67	9.42	65	111	25.3 (24.7)	$4.50 \times 10^{-5}$	1006	3541	2.9
200 W	1/5	R88G-HPG14A05200PB□	600	2.49	78	1000	7.01	$2.07 \times 10^{-5}$	221	883	0.99
	1/11	R88G-HPG20A11200PB□	273	4.75	68	454	13.4	$5.80 \times 10^{-5}$	659	2320	3.1
	1/21	R88G-HPG20A21200PB□	143	10.2	76	238	28.8	$4.90 \times 10^{-5}$	800	2817	3.1
	1/33	R88G-HPG20A33200PB□	91	17.0	81	151	47.9	$4.50 \times 10^{-5}$	916	3226	3.1
	1/45	R88G-HPG20A45200PB□	67	23.2	81	111	65.4	$4.50 \times 10^{-5}$	1006	3541	3.1
400 W	1/5	R88G-HPG20A05400PB□	600	4.67	72	1000 (900)	13.1 (12.9)	$7.10 \times 10^{-5}$	520	1832	3.1
	1/11	R88G-HPG20A11400PB□	273	11.7	82	454 (409)	32.9 (32.4)	$5.80 \times 10^{-5}$	659	2320	3.1
	1/21	R88G-HPG20A21400PB□	143	23.5	86	238 (214)	66.2 (65.2)	$4.90 \times 10^{-5}$	800	2817	3.1
	1/33	R88G-HPG32A33400PB□	91	34.7	81	151 (136)	97.6 (96.2)	$2.80 \times 10^{-4}$	1565	6240	7.8
	1/45	R88G-HPG32A45400PB□	67	47.4	81	111 (100)	133.0 (131.2)	$2.80 \times 10^{-4}$	1718	6848	7.8

**Note 1.** The values inside parentheses ( ) are for 100-V Servomotors.

**Note 2.** The Decelerator inertia is the Servomotor shaft conversion value.

**Note 3.** The protective structure for Servomotors with Decelerators satisfies IP44.

**Note 4.** The allowable radial load is the value at the T/2 position.

**Note 5.** The standard models have a straight shaft. Models with a key and tap are indicated with “J” at the end of the model number (the suffix in the box).

■ Backlash = 15' Max.

#### Decelerators for 3,000-r/min Servomotors

Model		Rated rotation speed	Rated torque	Efficiency	Maximum momentary rotation speed	Maximum momentary torque	Decelerator inertia	Allowable radial load	Allowable thrust load	Weight	
		r/min	N·m	%	r/min	N·m	kg·m <sup>2</sup>	N	N	kg	
50 W	1/5	R88G-VRSF05B100CJ	600	0.52	65	1000	1.46	$4.00 \times 10^{-6}$	392	196	0.55
	1/9	R88G-VRSF09B100CJ	333	0.93	65	556	2.63	$3.50 \times 10^{-6}$	441	220	0.55
	1/15	R88G-VRSF15B100CJ	200	1.67	70	333	4.73	$3.50 \times 10^{-6}$	588	294	0.70
	1/25	R88G-VRSF25B100CJ	120	2.78	70	200	7.88	$3.25 \times 10^{-6}$	686	343	0.70
100 W	1/5	R88G-VRSF05B100CJ	600	1.19	75	1000	3.38	$4.00 \times 10^{-6}$	392	196	0.55
	1/9	R88G-VRSF09B100CJ	333	2.29	80	556	6.48	$3.50 \times 10^{-6}$	441	220	0.55
	1/15	R88G-VRSF15B100CJ	200	3.81	80	333	10.8	$3.50 \times 10^{-6}$	588	294	0.70
	1/25	R88G-VRSF25B100CJ	120	6.36	80	200	18.0	$3.25 \times 10^{-6}$	686	343	0.70
200 W	1/5	R88G-VRSF05B200CJ	600	2.70	85	1000	7.57	$1.18 \times 10^{-5}$	392	196	0.72
	1/9	R88G-VRSF09C200CJ	333	3.77	66	556	10.6	$2.75 \times 10^{-5}$	931	465	1.70
	1/15	R88G-VRSF15C200CJ	200	6.29	66	333	17.6	$3.00 \times 10^{-5}$	1176	588	2.10
	1/25	R88G-VRSF25C200CJ	120	11.1	70	200	31.2	$2.88 \times 10^{-5}$	1323	661	2.10

### 3-3 Decelerator Specifications

Model		Rated rotation speed	Rated torque	Efficiency	Maximum momentary rotation speed	Maximum momentary torque	Decelerator inertia	Allowable radial load	Allowable thrust load	Weight	
		r/min	N·m	%	r/min	N·m	kg·m <sup>2</sup>	N	N	kg	
400 W	1/5	R88G-VRSF05C400CJ	600	5.40	85	1000	15.6 (15.3)	$3.63 \times 10^{-5}$	784	392	1.70
	1/9	R88G-VRSF09C400CJ	333	9.50	83	556	27.4 (26.8)	$2.75 \times 10^{-5}$	931	465	1.70
	1/15	R88G-VRSF15C400CJ	200	15.8	83	333	45.7 (44.8)	$3.00 \times 10^{-5}$	1176	588	2.10
	1/25	R88G-VRSF25C400CJ	120	26.4	83	200	76.1 (74.7)	$2.88 \times 10^{-5}$	1323	661	2.10
750 W	1/5	R88G-VRSF05C750CJ	600	10.7	90	1000	31.7	$7.13 \times 10^{-5}$	784	392	2.10
	1/9	R88G-VRSF09D750CJ	333	18.2	85	556	53.9	$6.50 \times 10^{-5}$	1176	588	3.40
	1/15	R88G-VRSF15D750CJ	200	30.4	85	333	89.9	$7.00 \times 10^{-5}$	1372	686	3.80
	1/25	R88G-VRSF25D750CJ	120	50.7	85	200	149.8	$6.80 \times 10^{-5}$	1617	808	3.80

**Note 1.** The values inside parentheses ( ) are for 100-V Servomotors.

**Note 2.** The Decelerator inertia is the Servomotor shaft conversion value.

**Note 3.** The protective structure for Servomotors with Decelerators satisfies IP44.

**Note 4.** The allowable radial load is the value at the T/2 position.

**Note 5.** The standard models have a straight shaft with a key.

## Decelerators for 3,000-r/min Flat Servomotors

Model		Rated rotation speed	Rated torque	Efficiency	Maximum momentary rotation speed	Maximum momentary torque	Decelerator inertia	Allowable radial load	Allowable thrust load	Weight	
		r/min	N·m	%	r/min	N·m	kg·m <sup>2</sup>	N	N	kg	
100 W	1/5	R88G-VRSF05B100PCJ	600	1.19	75	1000	3.15	$4.00 \times 10^{-6}$	392	196	0.72
	1/9	R88G-VRSF09B100PCJ	333	2.29	80	556	6.048	$3.50 \times 10^{-6}$	441	220	0.72
	1/15	R88G-VRSF15B100PCJ	200	3.81	80	333	10.08	$3.50 \times 10^{-6}$	588	294	0.87
	1/25	R88G-VRSF25B100PCJ	120	6.36	80	200	16.8	$3.25 \times 10^{-6}$	686	343	0.87
200 W	1/5	R88G-VRSF05B200PCJ	600	2.70	85	1000	7.65	$1.18 \times 10^{-5}$	392	196	0.85
	1/9	R88G-VRSF09C200PCJ	333	3.77	66	556	10.692	$2.75 \times 10^{-5}$	931	465	1.80
	1/15	R88G-VRSF15C200PCJ	200	6.29	66	333	17.82	$3.00 \times 10^{-5}$	1176	588	2.20
	1/25	R88G-VRSF25C200PCJ	120	11.1	70	200	31.5	$2.88 \times 10^{-5}$	1323	661	2.20
400 W	1/5	R88G-VRSF05C400PCJ	600	5.40	85	1000 (900)	15.5 (15.3)	$3.63 \times 10^{-5}$	784	392	1.80
	1/9	R88G-VRSF09C400PCJ	333	9.50	83	556 (500)	27.3 (26.9)	$2.75 \times 10^{-5}$	931	465	1.80
	1/15	R88G-VRSF15C400PCJ	200	15.8	83	333 (300)	45.4 (44.8)	$3.00 \times 10^{-5}$	1176	588	2.20
	1/25	R88G-VRSF25C400PCJ	120	26.4	83	200 (180)	75.7 (74.7)	$2.88 \times 10^{-5}$	1323	661	2.20

**Note 1.** The values inside parentheses ( ) are for 100-V Servomotors.

**Note 2.** The Decelerator inertia is the Servomotor shaft conversion value.

**Note 3.** The protective structure for Servomotors with Decelerators satisfies IP44.

**Note 4.** The allowable radial load is the value at the T/2 position.

**Note 5.** The standard models have a straight shaft with a key.

# 3-4 Cable and Connector Specifications

## Encoder Cable Specifications

These cables are used to connect the encoder between a Servo Drive and Servomotor. Select the Encoder Cable matching the Servomotor.

### Encoder Cables (Standard Cables)

#### R88A-CRGA□C

##### Cable Models

For absolute encoders: 3,000-r/min Servomotors of 50 to 750 W and 3,000-r/min Flat Servomotors of 100 to 400 W

Model	Length (L)	Outer diameter of sheath	Weight
R88A-CRGA003C	3 m	6.5 dia.	Approx. 0.2 kg
R88A-CRGA005C	5 m		Approx. 0.3 kg
R88A-CRGA010C	10 m		Approx. 0.6 kg
R88A-CRGA015C	15 m		Approx. 0.9 kg
R88A-CRGA020C	20 m		Approx. 1.2 kg
R88A-CRGA030C	30 m	6.8 dia.	Approx. 2.4 kg
R88A-CRGA040C	40 m		Approx. 3.2 kg
R88A-CRGA050C	50 m		Approx. 4.0 kg

### Connection Configuration and Dimensions

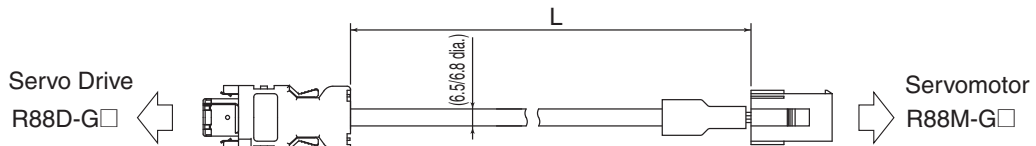

### Wiring

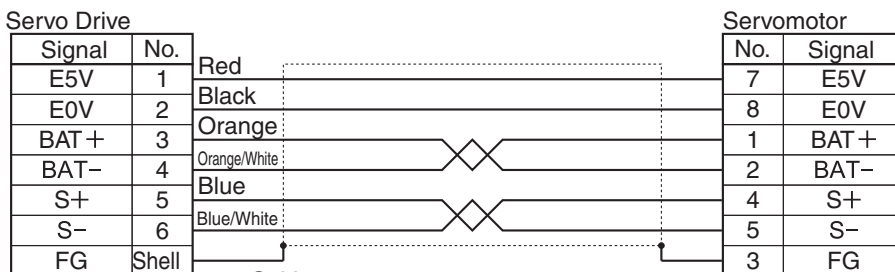

Cable:  
 AWG22 × 2C + AWG24×2P UL20276 (3 to 20 m)  
 AWG16 × 2C + AWG26×2P UL20276 (30 to 50 m)

Servo Drive Connector  
 Connector:

3 to 20 m: Crimp-type I/O Connector (Molex Japan)  
 30 to 50 m: 55100-0670 (Molex Japan)

Connector pins:  
 50639-8028 (Molex Japan)

Servomotor Connector  
 Connector:

172161-1 (Tyco Electronics AMP KK)  
 Connector pins:

170365-1 (Tyco Electronics AMP KK)  
 171639-1 (Tyco Electronics AMP KK)  
 for AWG16



**R88A-CRGB□C**

**Cable Models**

For incremental encoders: 3,000-r/min Servomotors of 50 to 750 W and 3,000-r/min Flat Servomotors of 100 to 400 W

Model	Length (L)	Outer diameter of sheath	Weight
R88A-CRGB003C	3 m	6.5 dia.	Approx. 0.2 kg
R88A-CRGB005C	5 m		Approx. 0.3 kg
R88A-CRGB010C	10 m		Approx. 0.6 kg
R88A-CRGB015C	15 m		Approx. 0.9 kg
R88A-CRGB020C	20 m		Approx. 1.2 kg
R88A-CRGB030C	30 m	6.8 dia.	Approx. 2.4 kg
R88A-CRGB040C	40 m		Approx. 3.2 kg
R88A-CRGB050C	50 m		Approx. 4.0 kg

**Connection Configuration and Dimensions**

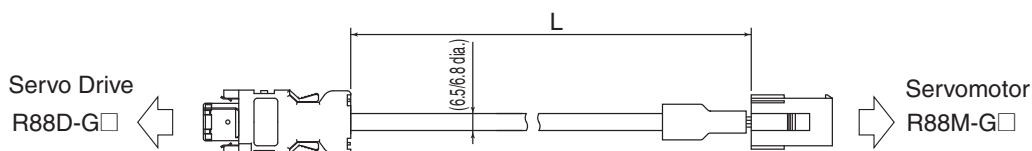

**Wiring**

Servo Drive	
Signal	No.
E5V	1
E0V	2
S+	5
S-	6
FG	Shell

Servomotor	
No.	Signal
4	E5V
5	E0V
2	S+
3	S-
6	FG

Cable

Servo Drive Connector: AWG22 × 2C + AWG24×2P UL20276 (3 to 20 m)  
 Connector: 3 to 20 m: Crimp-type I/O Connector (Molex Japan)  
 30 to 50 m: 55100-0670 (Molex Japan)  
 Connector pins: 50639-8028 (Molex Japan)

Servomotor Connector: 172161-1 (Tyco Electronics AMP KK)  
 Connector pins: 170365-1 (Tyco Electronics AMP KK)  
 171639-1 (Tyco Electronics AMP KK)  
 for AWG16

### 3-4 Cable and Connector Specifications

#### R88A-CRGC□N

##### Cable Models

For both absolute encoders and incremental encoders: 3,000-r/min Servomotors of 1 to 5 kW, 2,000-r/min Servomotors of 1 to 5 kW, 1,500-r/min Servomotors of 7.5 kW, and 1,000-r/min Servomotors of 900 W to 6 kW

Model	Length (L)	Outer diameter of sheath	Weight
R88A-CRGC003N	3 m	6.5 dia.	Approx. 0.3 kg
R88A-CRGC005N	5 m		Approx. 0.4 kg
R88A-CRGC010N	10 m		Approx. 0.7 kg
R88A-CRGC015N	15 m		Approx. 1.0 kg
R88A-CRGC020N	20 m		Approx. 1.5 kg
R88A-CRGC030N	30 m	6.8 dia.	Approx. 2.5 kg
R88A-CRGC040N	40 m		Approx. 3.3 kg
R88A-CRGC050N	50 m		Approx. 4.1 kg

##### Connection Configuration and Dimensions

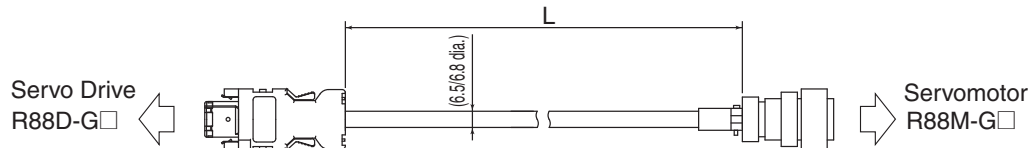

##### Wiring

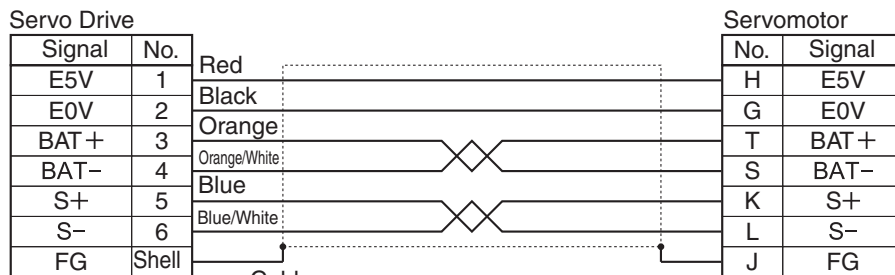

Cable:

Servo Drive Connector  
Connector: AWG22 × 2C + AWG24×2P UL20276 (3 to 20 m)  
30 to 50 m: AWG16 × 2C + AWG26×2P UL20276 (30 to 50 m)

3 to 20 m: Crimp-type I/O Connector (Molex Japan)  
30 to 50 m: 55100-0670 (Molex Japan)

Connector pins:  
50639-8028 (Molex Japan)

Servomotor Connector

Straight plug:  
N/MS3106B20-29S  
(Japan Aviation Electronics)

Cable clamp:  
N/MS3057-12A  
(Japan Aviation Electronics)

Encoder Cables (Robot Cables)

R88A-CRGA□CR

Cable Models

For absolute encoders: 3,000-r/min Servomotors of 50 to 750 W and 3,000-r/min Flat Servomotors of 100 to 400 W

Model	Length (L)	Outer diameter of sheath	Weight
R88A-CRGA003CR	3 m	7.5 dia.	Approx. 0.2 kg
R88A-CRGA005CR	5 m		Approx. 0.4 kg
R88A-CRGA010CR	10 m		Approx. 0.8 kg
R88A-CRGA015CR	15 m		Approx. 1.1 kg
R88A-CRGA020CR	20 m		Approx. 1.5 kg
R88A-CRGA030CR	30 m	8.2 dia.	Approx. 2.8 kg
R88A-CRGA040CR	40 m		Approx. 3.7 kg
R88A-CRGA050CR	50 m		Approx. 4.6 kg

Connection Configuration and Dimensions

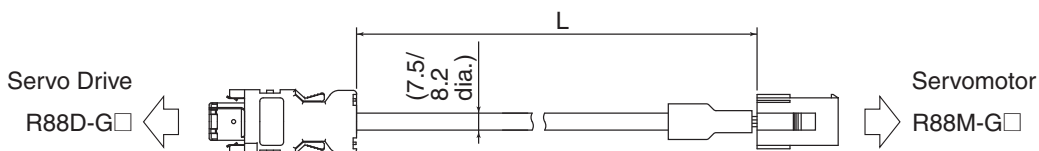

Wiring (3 to 20 m)

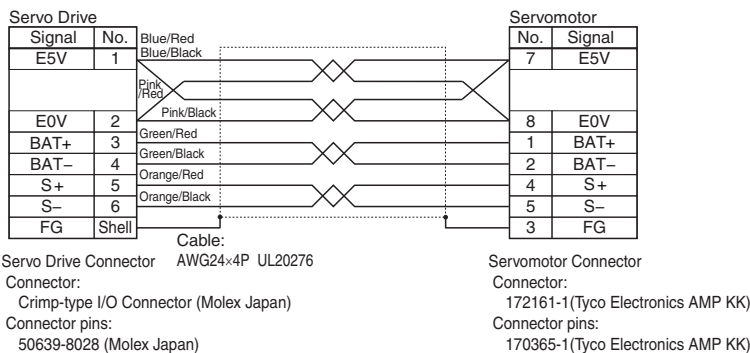

Wiring (30 to 50 m)

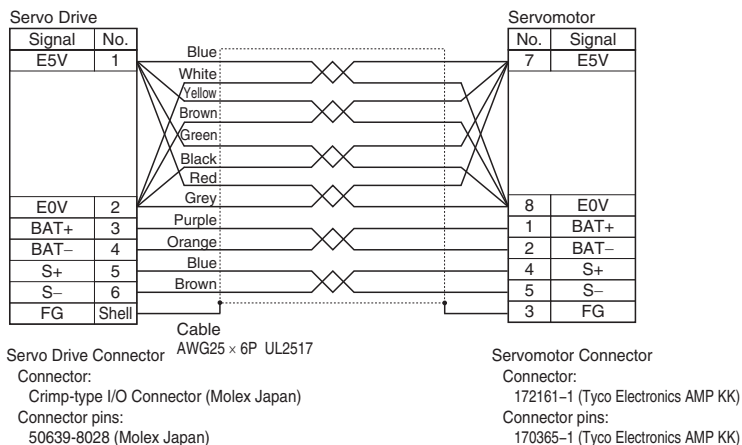

### 3-4 Cable and Connector Specifications

#### R88A-CRGB□CR

##### Cable Models

For incremental encoders: 3,000-r/min Servomotors of 50 to 750 W and 3,000-r/min Flat Servomotors of 100 to 400 W

Model	Length (L)	Outer diameter of sheath	Weight
R88A-CRGB003CR	3 m	7.5 dia.	Approx. 0.2 kg
R88A-CRGB005CR	5 m		Approx. 0.4 kg
R88A-CRGB010CR	10 m		Approx. 0.8 kg
R88A-CRGB015CR	15 m		Approx. 1.1 kg
R88A-CRGB020CR	20 m		Approx. 1.5 kg
R88A-CRGB030CR	30 m	8.2 dia.	Approx. 2.8 kg
R88A-CRGB040CR	40 m		Approx. 3.7 kg
R88A-CRGB050CR	50 m		Approx. 4.6 kg

##### Connection Configuration and Dimensions

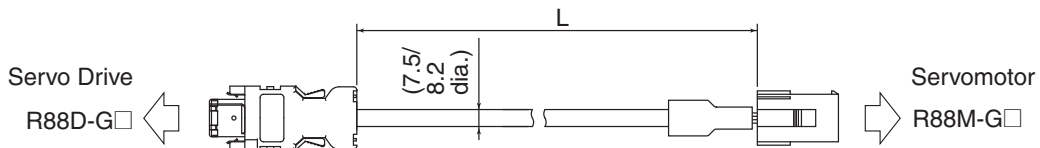

##### Wiring (3 to 20 m)

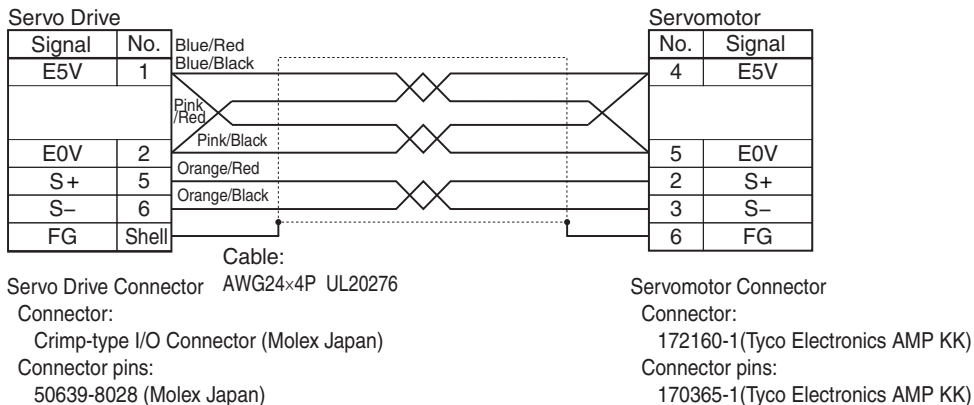

##### Wiring (30 to 50 m)

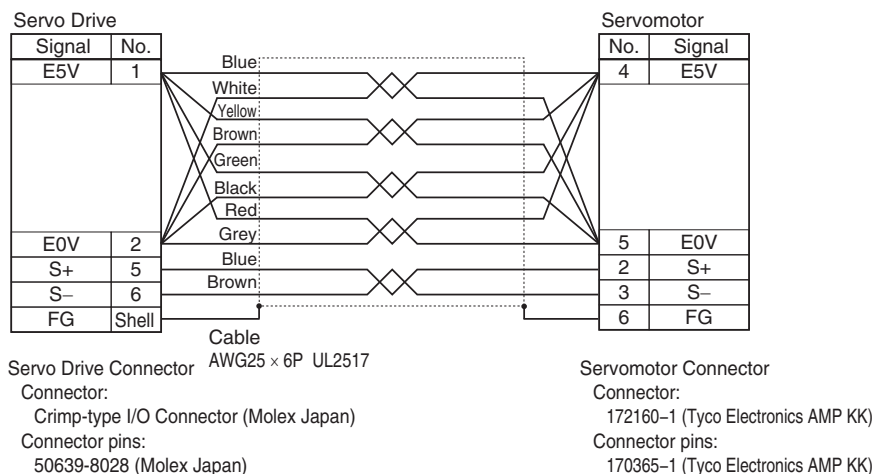

**R88A-CRGC□NR**

**Cable Models**

For both absolute encoders and incremental encoders: 3,000-r/min Servomotors of 1 to 5 kW, 2,000-r/min Servomotors of 1 to 5 kW, 1,000-r/min Servomotors of 900 W to 4.5 kW

Model	Length (L)	Outer diameter of sheath	Weight
R88A-CRGC003NR	3 m	7.5 dia.	Approx. 0.4 kg
R88A-CRGC005NR	5 m		Approx. 0.5 kg
R88A-CRGC010NR	10 m		Approx. 0.9 kg
R88A-CRGC015NR	15 m		Approx. 1.3 kg
R88A-CRGC020NR	20 m		Approx. 1.6 kg
R88A-CRGC030NR	30 m	8.2 dia.	Approx. 2.9 kg
R88A-CRGC040NR	40 m		Approx. 3.8 kg
R88A-CRGC050NR	50 m		Approx. 4.7 kg

**Connection Configuration and Dimensions**

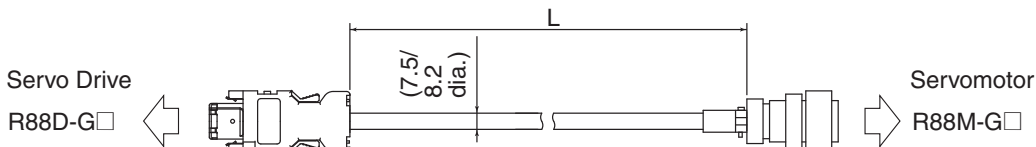

**Wiring (3 to 20 m)**

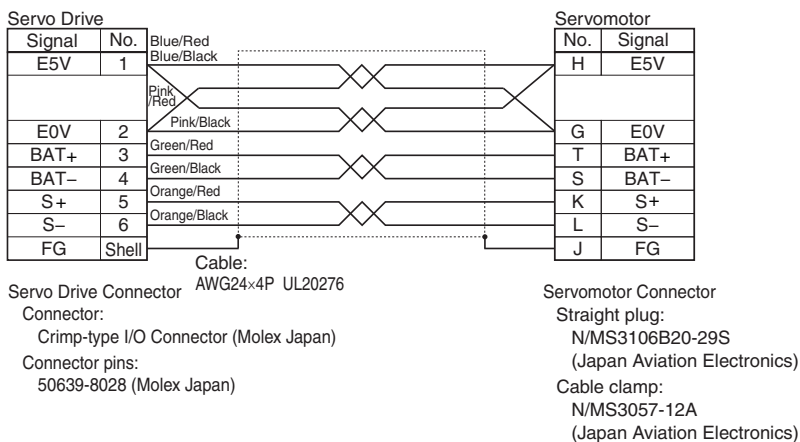

**Wiring (30 to 50 m)**

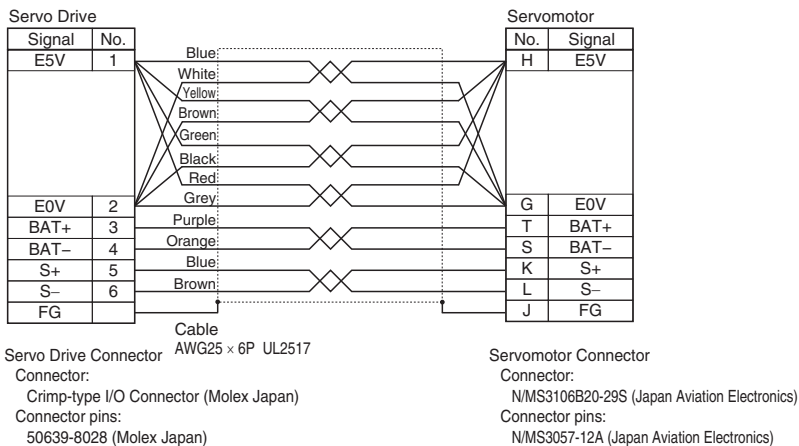

**Absolute Encoder Battery Cable Specifications** ABS

**Cable Models**

Model	Length (L)
R88A-CRGD0R3C	0.3 m

**Connection Configuration and Dimensions**

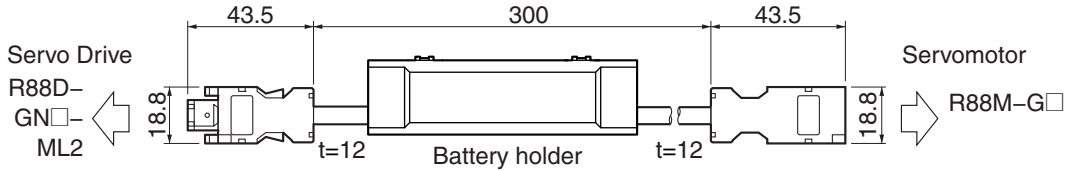

**Wiring**

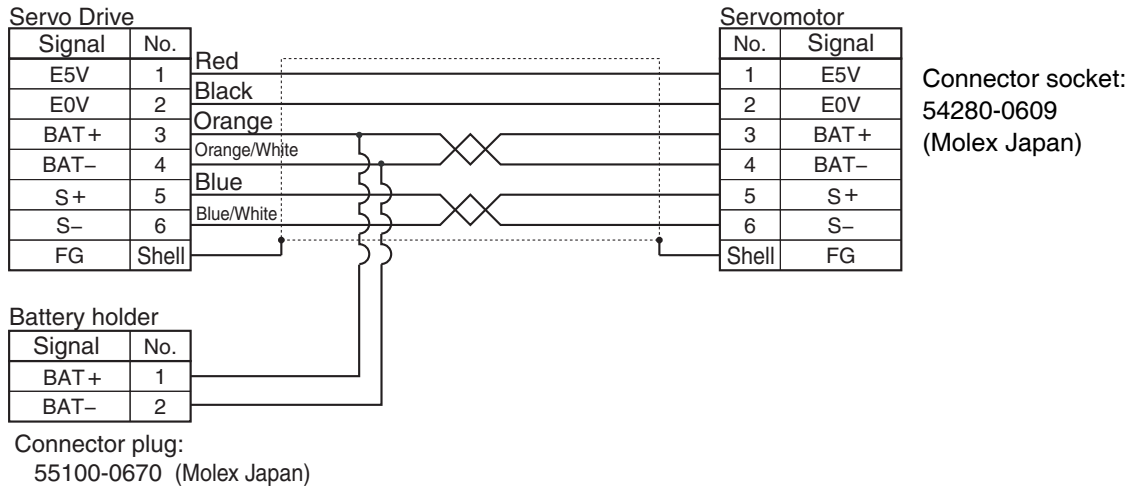

## Servomotor Power Cable Specifications

These cables connect the Servo Drive and Servomotor. Select the cable matching the Servomotor.

**Precautions for Correct Use**

♦Use a robot cable if the Servomotor is to be used on moving parts.

### ■ Power Cables for Servomotors without Brakes (Standard Cables)

#### R88A-CAGA□S

**Cable Models**

For 3,000-r/min Servomotors of 50 to 750 W and 3,000-r/min Flat Servomotors of 100 to 400 W

Model	Length (L)	Outer diameter of sheath	Weight
R88A-CAGA003S	3 m	6.2 dia.	Approx. 0.2 kg
R88A-CAGA005S	5 m		Approx. 0.3 kg
R88A-CAGA010S	10 m		Approx. 0.6 kg
R88A-CAGA015S	15 m		Approx. 0.9 kg
R88A-CAGA020S	20 m		Approx. 1.2 kg
R88A-CAGA030S	30 m		Approx. 1.8 kg
R88A-CAGA040S	40 m		Approx. 2.4 kg
R88A-CAGA050S	50 m		Approx. 3.0 kg

#### Connection Configuration and Dimensions

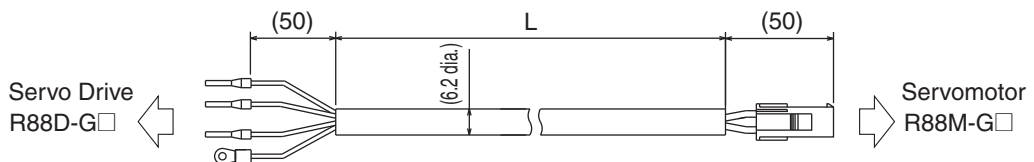

#### Wiring

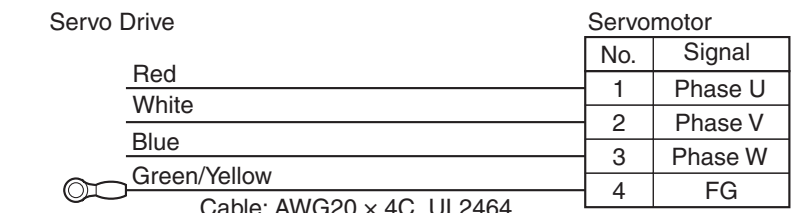

Cable: AWG20 x 4C UL2464  
M4 crimp terminals

#### Servomotor Connector

Connector:

172159-1 (Tyco Electronics AMP KK)

Connector pins:

170362-1 (Tyco Electronics AMP KK)

170366-1 (Tyco Electronics AMP KK)

### 3-4 Cable and Connector Specifications

#### R88A-CAGB□S

##### Cable Models

For 3,000-r/min Servomotors of 1 to 1.5 kW, 2,000-r/min Servomotors of 1 to 1.5 kW, and 1,000-r/min Servomotors of 900 W

Model	Length (L)	Outer diameter of sheath	Weight
R88A-CAGB003S	3 m	10.4 dia.	Approx. 0.7 kg
R88A-CAGB005S	5 m		Approx. 1.0 kg
R88A-CAGB010S	10 m		Approx. 2.0 kg
R88A-CAGB015S	15 m		Approx. 2.9 kg
R88A-CAGB020S	20 m		Approx. 3.8 kg
R88A-CAGB030S	30 m		Approx. 5.6 kg
R88A-CAGB040S	40 m		Approx. 7.4 kg
R88A-CAGB050S	50 m		Approx. 9.2 kg

##### Connection Configuration and Dimensions

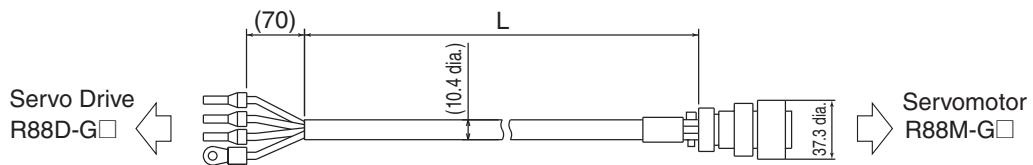

##### Wiring

Servo Drive	Servomotor	
	No.	Signal
Red	A	Phase U
White	B	Phase V
Blue	C	Phase W
Green/Yellow	D	FG

Cable: AWG14 × 4C UL2463

M4 crimp terminals

Servomotor Connector

Straight plug:

N/MS3106B20-4S (Japan Aviation Electronics)

Cable clamp:

N/MS3057-12A (Japan Aviation Electronics)



**R88A-CAGC□S**

**Cable Models**

For 3,000-r/min Servomotors of 2 kW and 2,000-r/min Servomotors of 2 kW

Model	Length (L)	Outer diameter of sheath	Weight
R88A-CAGC003S	3 m	10.4 dia.	Approx. 0.7 kg
R88A-CAGC005S	5 m		Approx. 1.0 kg
R88A-CAGC010S	10 m		Approx. 2.0 kg
R88A-CAGC015S	15 m		Approx. 2.9 kg
R88A-CAGC020S	20 m		Approx. 3.8 kg
R88A-CAGC030S	30 m		Approx. 5.6 kg
R88A-CAGC040S	40 m		Approx. 7.4 kg
R88A-CAGC050S	50 m		Approx. 9.2 kg

**Connection Configuration and Dimensions**

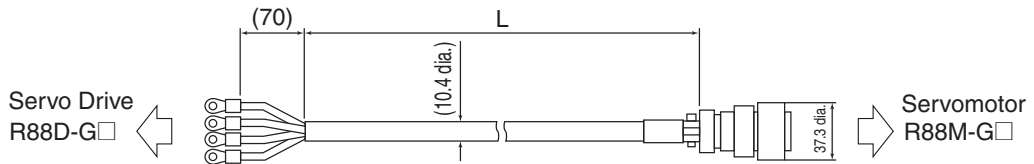

**Wiring**

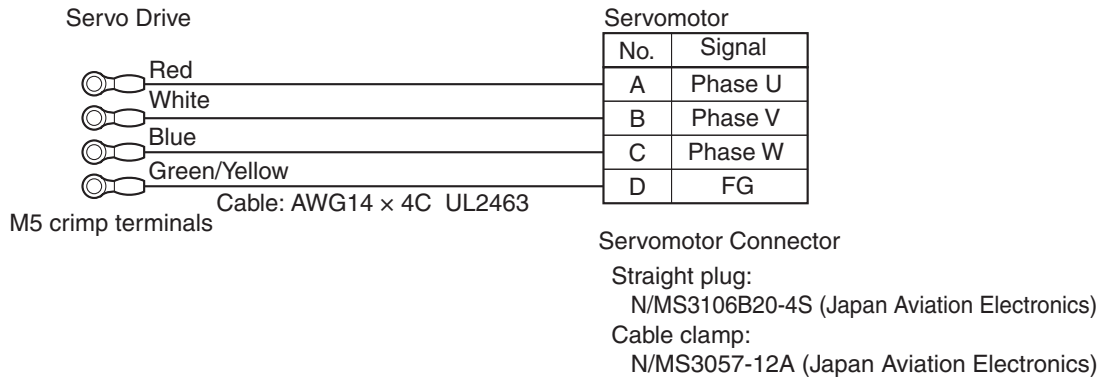

### 3-4 Cable and Connector Specifications

#### R88A-CAGD□S

##### Cable Models

For 3,000-r/min Servomotors of 3 to 5 kW, 2,000-r/min Servomotors of 3 to 5 kW, and 1,000-r/min Servomotors of 2 to 4.5 kW

Model	Length (L)	Outer diameter of sheath	Weight
R88A-CAGD003S	3 m	14.7 dia.	Approx. 1.3 kg
R88A-CAGD005S	5 m		Approx. 2.1 kg
R88A-CAGD010S	10 m		Approx. 4.0 kg
R88A-CAGD015S	15 m		Approx. 6.0 kg
R88A-CAGD020S	20 m		Approx. 8.0 kg
R88A-CAGD030S	30 m		Approx. 11.9 kg
R88A-CAGD040S	40 m		Approx. 15.8 kg
R88A-CAGD050S	50 m		Approx. 19.7 kg

##### Connection Configuration and Dimensions

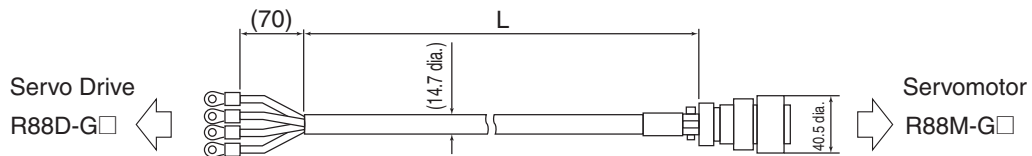

##### Wiring

Servo Drive

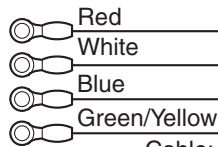

Cable: AWG10 × 4C UL2463

M5 crimp terminals

Servomotor

No.	Signal
A	Phase U
B	Phase V
C	Phase W
D	FG

Servomotor Connector

Straight plug:

N/MS3106B22-22S (Japan Aviation Electronics)

Cable clamp:

N/MS3057-12A (Japan Aviation Electronics)

**R88A-CAGE□S**

**Cable Models**

For 1,500-r/min Servomotors of 7.5 kW and 1,000-r/min Servomotors of 6 kW

Model	Length (L)	Outer diameter of sheath	Weight
R88A-CAGE003S	3 m	28.5 dia.	Approx. 4.0 kg
R88A-CAGE005S	5 m		Approx. 6.5 kg
R88A-CAGE010S	10 m		Approx. 12.6 kg
R88A-CAGE015S	15 m		Approx. 18.8 kg
R88A-CAGE020S	20 m		Approx. 24.9 kg
R88A-CAGE030S	30 m		Approx. 37.2 kg
R88A-CAGE040S	40 m		Approx. 49.5 kg
R88A-CAGE050S	50 m		Approx. 61.8 kg

**Connection Configuration and Dimensions**

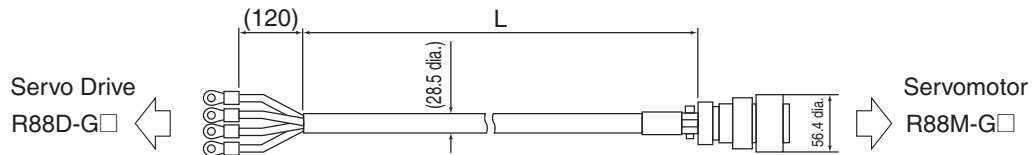

**Wiring**

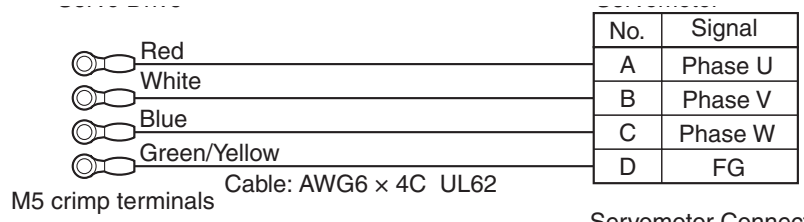

Servomotor Connector

Straight plug:

N/MS3106B32-17S (Japan Aviation Electronics)

Cable clamp:

N/MS3057-20A (Japan Aviation Electronics)

### 3-4 Cable and Connector Specifications

#### ■ Power Cables for Servomotors without Brakes (Robot Cables)

##### R88A-CAGA□SR

###### Cable Models

For 3,000-r/min Servomotors of 50 to 750 W and 3,000-r/min Flat Servomotors of 100 to 400 W

Model	Length (L)	Outer diameter of sheath	Weight
R88A-CAGA003SR	3 m	6.9 dia.	Approx. 0.2 kg
R88A-CAGA005SR	5 m		Approx. 0.3 kg
R88A-CAGA010SR	10 m		Approx. 0.7 kg
R88A-CAGA015SR	15 m		Approx. 1.0 kg
R88A-CAGA020SR	20 m		Approx. 1.3 kg
R88A-CAGA030SR	30 m		Approx. 1.9 kg
R88A-CAGA040SR	40 m		Approx. 2.6 kg
R88A-CAGA050SR	50 m		Approx. 3.2 kg

###### Connection Configuration and Dimensions

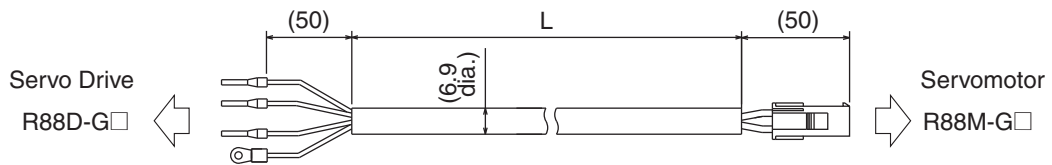

###### Wiring

Servo Drive

Red	
White	
Black	
Green/Yellow	

Cable: AWG20×4C UL2464

M4 crimp terminals

Servomotor

No.	Signal
1	Phase U
2	Phase V
3	Phase W
4	FG

Servomotor Connector  
Connector:

172159-1(Tyco Electronics AMP KK)

Connector pins:

170362-1(Tyco Electronics AMP KK)

170366-1(Tyco Electronics AMP KK)

**R88A-CAGB□SR**

**Cable Models**

For 3,000-r/min Servomotors of 1 to 1.5 kW, 2,000-r/min Servomotors of 1 to 1.5 kW, and 1,000-r/min Servomotors of 900 W

Model	Length (L)	Outer diameter of sheath	Weight
R88A-CAGB003SR	3 m	12.7 dia.	Approx. 0.8 kg
R88A-CAGB005SR	5 m		Approx. 1.3 kg
R88A-CAGB010SR	10 m		Approx. 2.4 kg
R88A-CAGB015SR	15 m		Approx. 3.5 kg
R88A-CAGB020SR	20 m		Approx. 4.6 kg
R88A-CAGB030SR	30 m		Approx. 6.9 kg
R88A-CAGB040SR	40 m		Approx. 9.2 kg
R88A-CAGB050SR	50 m		Approx. 11.4 kg

**Connection Configuration and Dimensions**

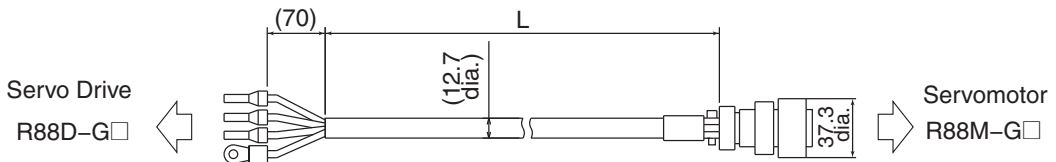

**Wiring**

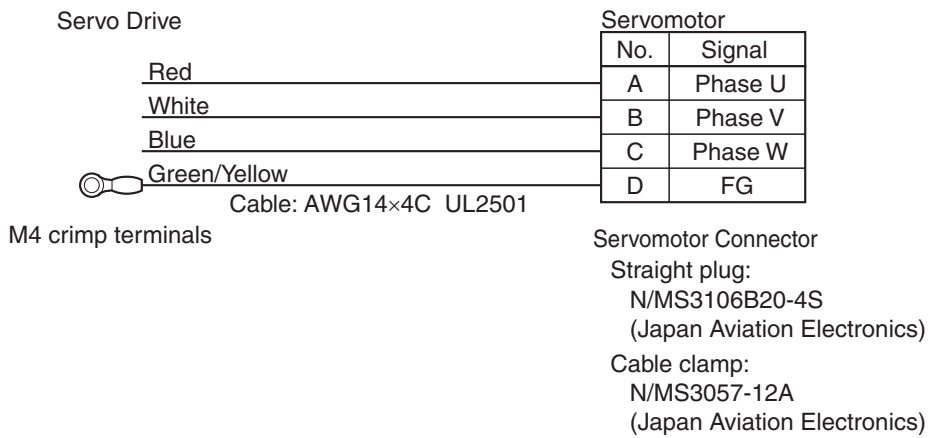

### 3-4 Cable and Connector Specifications

#### R88A-CAGC□SR

##### Cable Models

For 3,000-r/min Servomotors of 2 kW and 2,000-r/min Servomotors of 2 kW

Model	Length (L)	Outer diameter of sheath	Weight
R88A-CAGC003SR	3 m	12.7 dia.	Approx. 0.8 kg
R88A-CAGC005SR	5 m		Approx. 1.3 kg
R88A-CAGC010SR	10 m		Approx. 2.4 kg
R88A-CAGC015SR	15 m		Approx. 3.5 kg
R88A-CAGC020SR	20 m		Approx. 4.6 kg
R88A-CAGC030SR	30 m		Approx. 6.9 kg
R88A-CAGC040SR	40 m		Approx. 9.2 kg
R88A-CAGC050SR	50 m		Approx. 11.4 kg

##### Connection Configuration and Dimensions

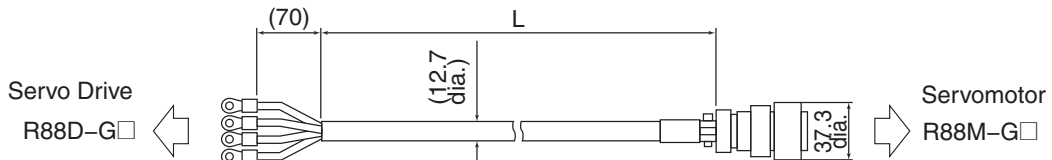

##### Wiring

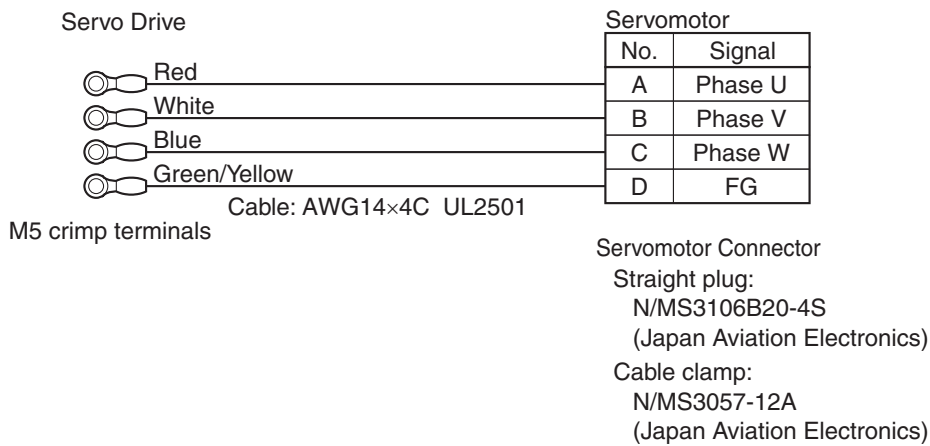

**R88A-CAGD□SR**

**Cable Models**

For 3,000-r/min Servomotors of 3 to 5 kW, 2,000-r/min Servomotors of 3 to 5 kW, and 1,000-r/min Servomotors of 2 to 4.5 kW

Model	Length (L)	Outer diameter of sheath	Weight
R88A-CAGD003SR	3 m	15.6 dia.	Approx. 1.4 kg
R88A-CAGD005SR	5 m		Approx. 2.2 kg
R88A-CAGD010SR	10 m		Approx. 4.2 kg
R88A-CAGD015SR	15 m		Approx. 6.3 kg
R88A-CAGD020SR	20 m		Approx. 8.3 kg
R88A-CAGD030SR	30 m		Approx. 12.4 kg
R88A-CAGD040SR	40 m		Approx. 16.5 kg
R88A-CAGD050SR	50 m		Approx. 20.5 kg

**Connection Configuration and Dimensions**

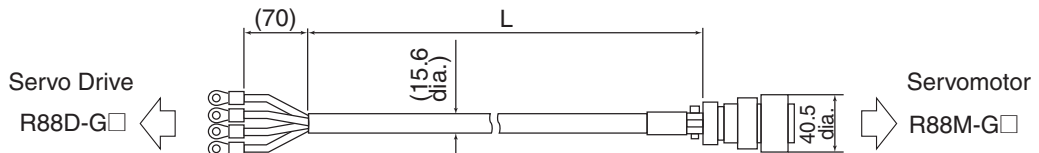

**Wiring**

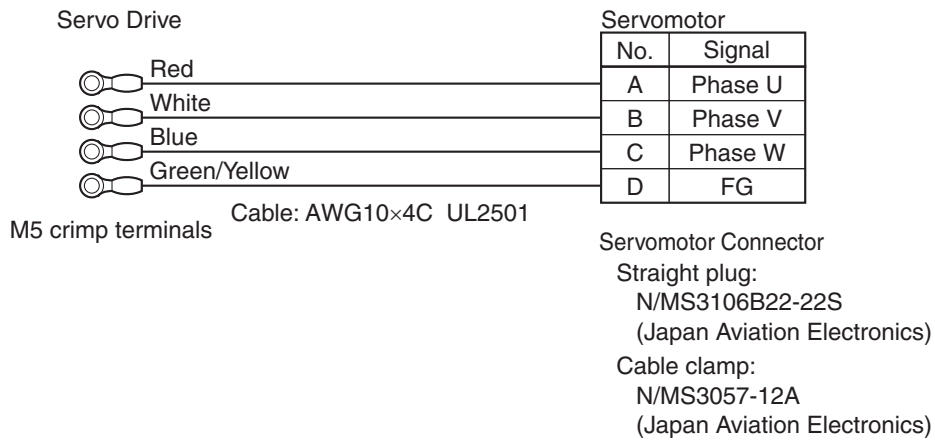

### 3-4 Cable and Connector Specifications

#### ■ Power Cables for Servomotors with Brakes (Standard Cables)

##### R88A-CAGB□B

##### Cable Models

For 3,000-r/min Servomotors of 1 to 1.5 kW, 2,000-r/min Servomotors of 1 to 1.5 kW, and 1,000-r/min Servomotors of 900 W

Model	Length (L)	Outer diameter of sheath	Weight
R88A-CAGB003B	3 m	10.4/5.4 dia.	Approx. 0.8 kg
R88A-CAGB005B	5 m		Approx. 1.3 kg
R88A-CAGB010B	10 m		Approx. 2.4 kg
R88A-CAGB015B	15 m		Approx. 3.5 kg
R88A-CAGB020B	20 m		Approx. 4.6 kg
R88A-CAGB030B	30 m		Approx. 6.8 kg
R88A-CAGB040B	40 m		Approx. 9.1 kg
R88A-CAGB050B	50 m		Approx. 11.3 kg

##### Connection Configuration and Dimensions

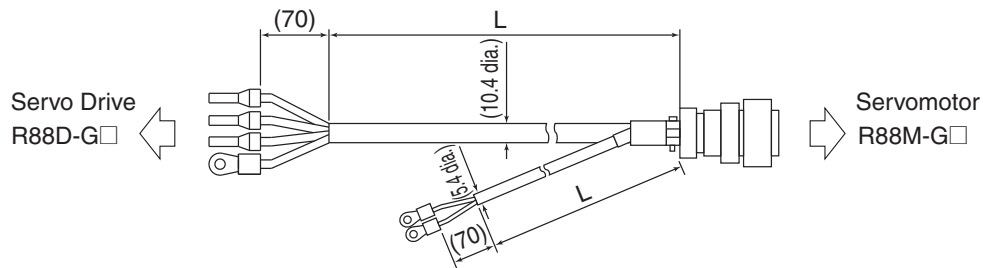

##### Wiring

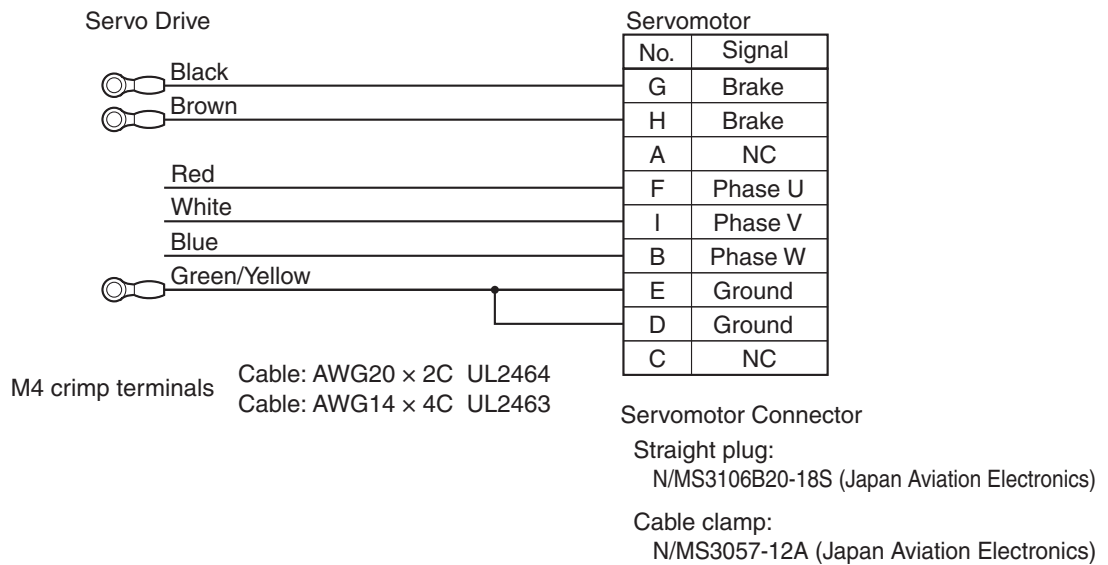



**R88A-CAGC□B**

**Cable Models**

For 3,000-r/min Servomotors of 2 kW and 2,000-r/min Servomotors of 2 kW

Model	Length (L)	Outer diameter of sheath	Weight
R88A-CAGC003B	3 m	10.4/5.4 dia.	Approx. 0.8 kg
R88A-CAGC005B	5 m		Approx. 1.3 kg
R88A-CAGC010B	10 m		Approx. 2.4 kg
R88A-CAGC015B	15 m		Approx. 3.5 kg
R88A-CAGC020B	20 m		Approx. 4.6 kg
R88A-CAGC030B	30 m		Approx. 6.8 kg
R88A-CAGC040B	40 m		Approx. 9.1 kg
R88A-CAGC050B	50 m		Approx. 11.3 kg

**Connection Configuration and Dimensions**

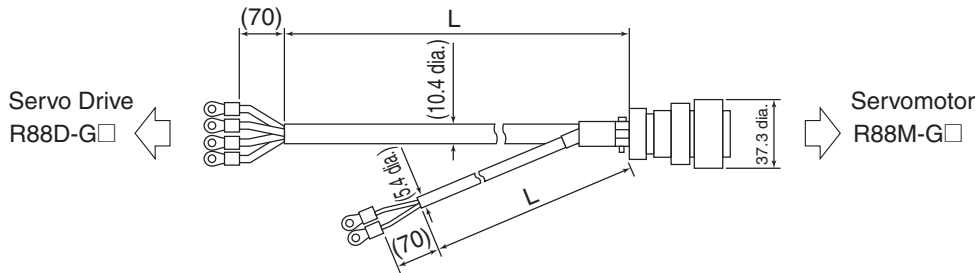

**Wiring**

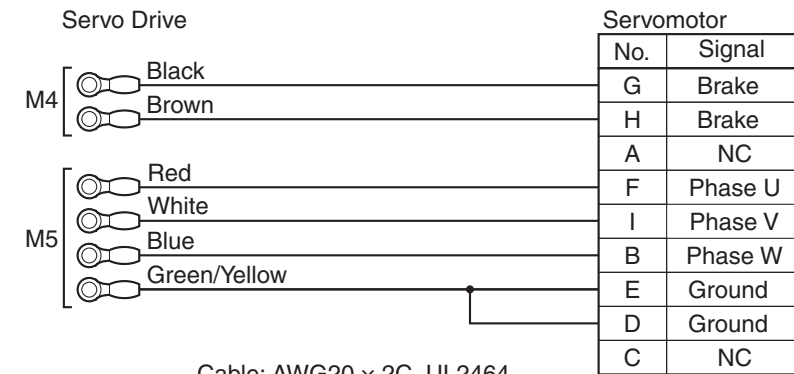

Crimp terminals Cable: AWG20 × 2C UL2464  
Cable: AWG14 × 4C UL2463

Servomotor Connector

Straight plug:

N/MS3106B20-18S (Japan Aviation Electronics)

Cable clamp:

N/MS3057-12A (Japan Aviation Electronics)

### 3-4 Cable and Connector Specifications

#### R88A-CAGD□B

##### Cable Models

For 3,000-r/min Servomotors of 3 to 5 kW, 2,000-r/min Servomotors of 3 to 5 kW, and 1,000-r/min Servomotors of 2 to 4.5 kW

Model	Length (L)	Outer diameter of sheath	Weight
R88A-CAGD003B	3 m	14.7/5.4 dia.	Approx. 1.5 kg
R88A-CAGD005B	5 m		Approx. 2.4 kg
R88A-CAGD010B	10 m		Approx. 4.5 kg
R88A-CAGD015B	15 m		Approx. 6.7 kg
R88A-CAGD020B	20 m		Approx. 8.8 kg
R88A-CAGD030B	30 m		Approx. 13.1 kg
R88A-CAGD040B	40 m		Approx. 17.4 kg
R88A-CAGD050B	50 m		Approx. 21.8 kg

##### Connection Configuration and Dimensions

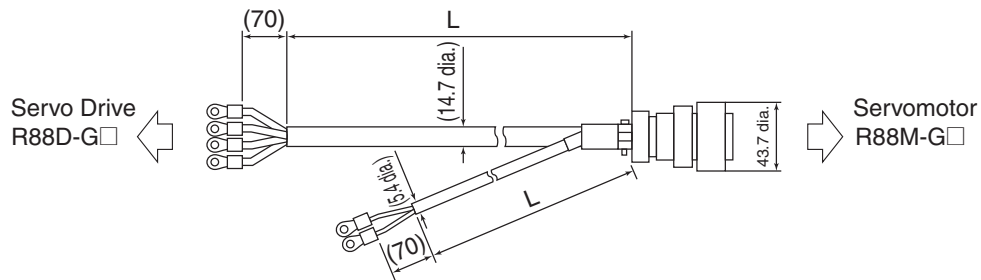

##### Wiring

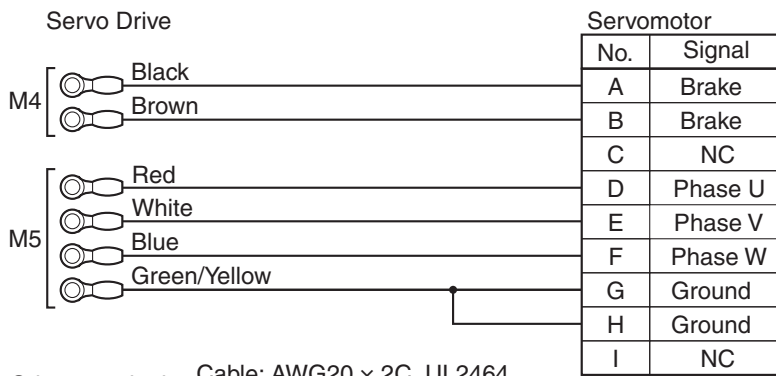

Crimp terminals Cable: AWG20 × 2C UL2464  
Cable: AWG10 × 4C UL2463

##### Servomotor Connector

Straight plug:  
N/MS3106B24-11S (Japan Aviation Electronics)

Cable clamp:  
N/MS3057-16A (Japan Aviation Electronics)

■ Power Cables for Servomotors with Brakes (Robot Cables)

R88A-CAGB□BR

Cable Models

For 3,000-r/min Servomotors of 1 to 1.5 kW, 2,000-r/min Servomotors of 1 to 1.5 kW, and 1,000-r/min Servomotors of 900 W

Model	Length (L)	Outer diameter of sheath	Weight
R88A-CAGB003BR	3 m	12.7/6.1 dia.	Approx. 0.9 kg
R88A-CAGB005BR	5 m		Approx. 1.5 kg
R88A-CAGB010BR	10 m		Approx. 2.8 kg
R88A-CAGB015BR	15 m		Approx. 4.2 kg
R88A-CAGB020BR	20 m		Approx. 5.5 kg
R88A-CAGB030BR	30 m		Approx. 8.2 kg
R88A-CAGB040BR	40 m		Approx. 10.9 kg
R88A-CAGB050BR	50 m		Approx. 13.6 kg

Connection Configuration and Dimensions

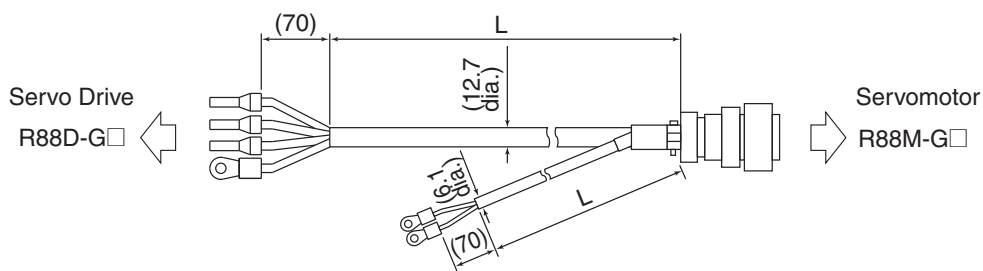

Wiring

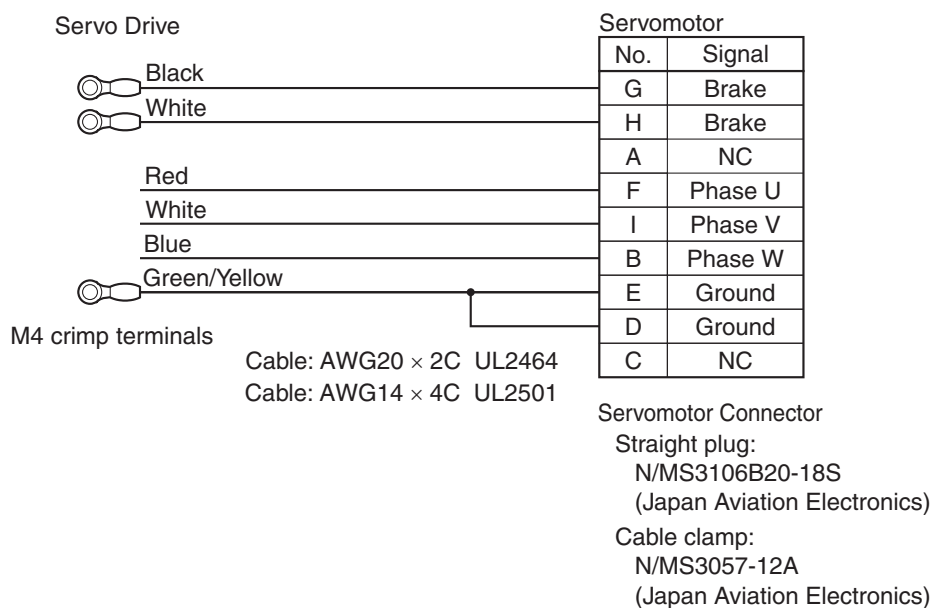

### 3-4 Cable and Connector Specifications

#### R88A-CAGC□BR

##### Cable Models

For 3,000-r/min Servomotors of 2 kW and 2,000-r/min Servomotors of 2 kW

Model	Length (L)	Outer diameter of sheath	Weight
R88A-CAGC003BR	3 m	12.7/6.1 dia.	Approx. 0.9 kg
R88A-CAGC005BR	5 m		Approx. 1.5 kg
R88A-CAGC010BR	10 m		Approx. 2.8 kg
R88A-CAGC015BR	15 m		Approx. 4.2 kg
R88A-CAGC020BR	20 m		Approx. 5.5 kg
R88A-CAGC030BR	30 m		Approx. 8.2 kg
R88A-CAGC040BR	40 m		Approx. 10.9 kg
R88A-CAGC050BR	50 m		Approx. 13.6 kg

##### Connection Configuration and Dimensions

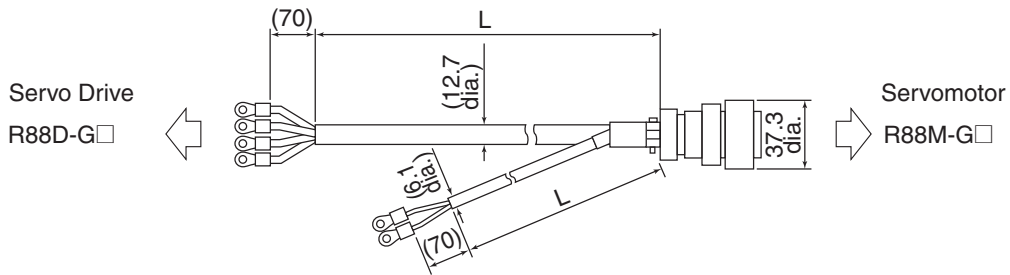

##### Wiring

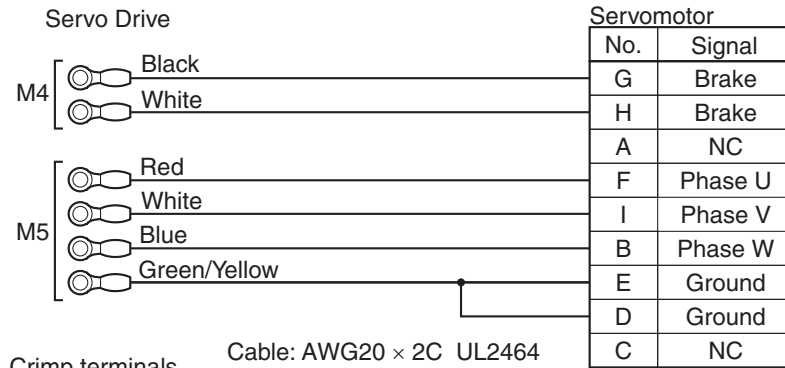

Crimp terminals

Cable: AWG20 × 2C UL2464  
Cable: AWG14 × 4C UL2501

Servomotor Connector

Straight plug:  
N/MS3106B20-18S  
(Japan Aviation Electronics)

Cable clamp:  
N/MS3057-12A  
(Japan Aviation Electronics)

**R88A-CAGD□BR**

**Cable Models**

For 3,000-r/min Servomotors of 3 to 5 kW, 2,000-r/min Servomotors of 3 to 5 kW, and 1,000-r/min Servomotors of 2 to 4.5 kW

Model	Length (L)	Outer diameter of sheath	Weight
R88A-CAGD003BR	3 m	15.6/6.1 dia.	Approx. 1.6 kg
R88A-CAGD005BR	5 m		Approx. 2.5 kg
R88A-CAGD010BR	10 m		Approx. 4.7 kg
R88A-CAGD015BR	15 m		Approx. 7.0 kg
R88A-CAGD020BR	20 m		Approx. 9.2 kg
R88A-CAGD030BR	30 m		Approx. 13.7 kg
R88A-CAGD040BR	40 m		Approx. 18.2 kg
R88A-CAGD050BR	50 m		Approx. 22.7 kg

**Connection Configuration and Dimensions**

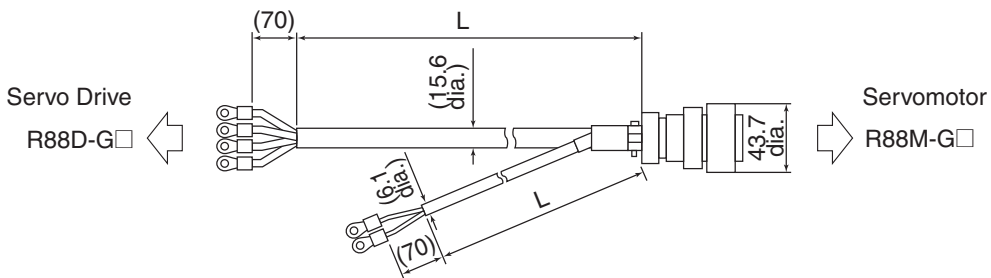

**Wiring**

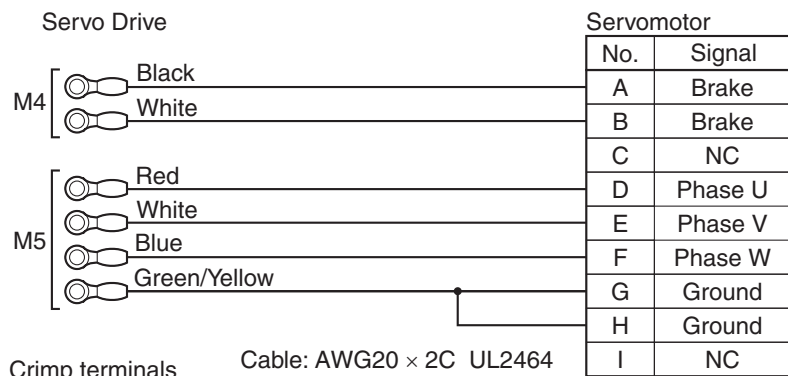

Crimp terminals Cable: AWG20 × 2C UL2464  
Cable: AWG10 × 4C UL2501

Servomotor Connector

Straight plug:  
N/MS3106B24-11S  
(Japan Aviation Electronics)

Cable clamp:  
N/MS3057-16A  
(Japan Aviation Electronics)

### 3-4 Cable and Connector Specifications

#### ■ Brake Cables (Standard Cables)

##### R88A-CAGA□B

###### Cable Models

For 3,000-r/min Servomotors of 50 to 750 W and 3,000-r/min Flat Servomotors of 100 to 400 W

Model	Length (L)	Outer diameter of sheath	Weight
R88A-CAGA003B	3 m	5.4 dia.	Approx. 0.1 kg
R88A-CAGA005B	5 m		Approx. 0.2 kg
R88A-CAGA010B	10 m		Approx. 0.4 kg
R88A-CAGA015B	15 m		Approx. 0.6 kg
R88A-CAGA020B	20 m		Approx. 0.8 kg
R88A-CAGA030B	30 m		Approx. 1.2 kg
R88A-CAGA040B	40 m		Approx. 1.6 kg
R88A-CAGA050B	50 m		Approx. 2.1 kg

###### Connection Configuration and Dimensions

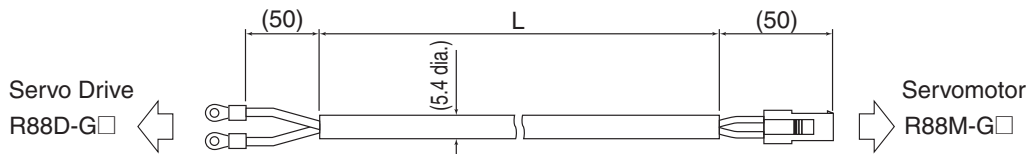

###### Wiring

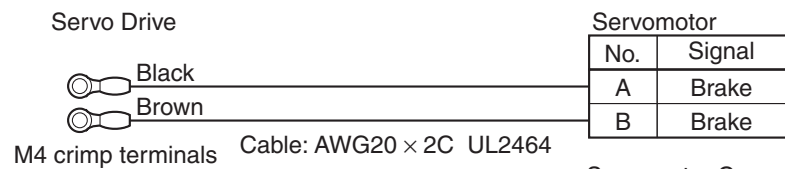

Servomotor Connector

Connector:

172157-1 (Tyco Electronics AMP KK)

Connector pins:

170362-1 (Tyco Electronics AMP KK)

170366-1 (Tyco Electronics AMP KK)

**R88A-CAGE□B**

**Cable Models**

For 1,500-r/min Servomotors of 7.5 kW and 1,000-r/min Servomotors of 6 kW

Model	Length (L)	Outer diameter of sheath	Weight
R88A-CAGE003B	3 m	5.4 dia.	Approx. 0.2 kg
R88A-CAGE005B	5 m		Approx. 0.3 kg
R88A-CAGE010B	10 m		Approx. 0.5 kg
R88A-CAGE015B	15 m		Approx. 0.7 kg
R88A-CAGE020B	20 m		Approx. 0.9 kg
R88A-CAGE030B	30 m		Approx. 1.3 kg
R88A-CAGE040B	40 m		Approx. 1.7 kg
R88A-CAGE050B	50 m		Approx. 2.1 kg

**Connection Configuration and Dimensions**

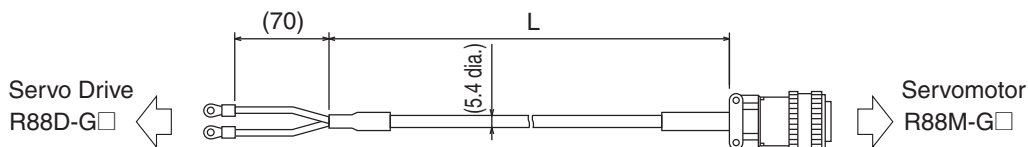

**Wiring**

Servo Drive

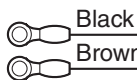

Cable: AWG20 × 2C UL2464  
M4 crimp terminals

Servomotor

No.	Signal
A	Brake
B	Brake

Servomotor Connector

Straight plug:

N/MS3106B14S-2S (Japan Aviation Electronics)

Cable clamp:

N/MS3057-6A (Japan Aviation Electronics)

### 3-4 Cable and Connector Specifications

#### ■ Brake Cables (Robot Cables)

##### R88A-CAGA□BR

###### Cable Models

For 3,000-r/min Servomotors of 50 to 750 W and 3,000-r/min Flat Servomotors of 100 to 400 W

Model	Length (L)	Outer diameter of sheath	Weight
R88A-CAGA003BR	3 m	6.1 dia.	Approx. 0.1 kg
R88A-CAGA005BR	5 m		Approx. 0.2 kg
R88A-CAGA010BR	10 m		Approx. 0.4 kg
R88A-CAGA015BR	15 m		Approx. 0.7 kg
R88A-CAGA020BR	20 m		Approx. 0.9 kg
R88A-CAGA030BR	30 m		Approx. 1.3 kg
R88A-CAGA040BR	40 m		Approx. 1.8 kg
R88A-CAGA050BR	50 m		Approx. 2.2 kg

###### Connection Configuration and Dimensions

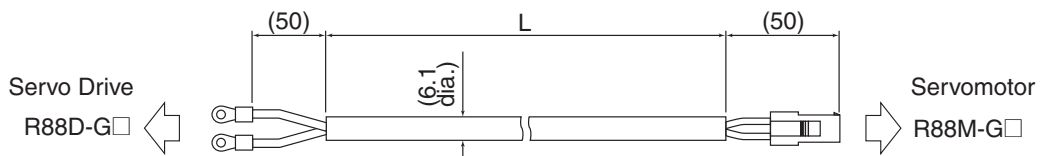

###### Wiring

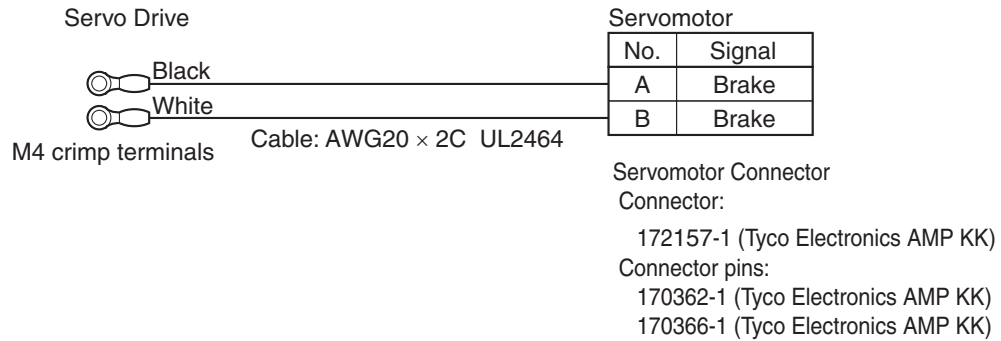



**Resistant to Bending of Robot Cables**

Use Robot Cable that can withstand at least 20 million bends to the minimum bending radius (R) given below or larger.

**Note 1.** The service life data for resistant to bending is based on test data. Use it for reference only, and provide sufficient allowance.

**Note 2.** This value is the number of bends when electricity is conducted through the conductors that will not result in cracking or damage to an extent that would affect the functionality of the sheath. Broken shield strands may occur.

**Note 3.** If a bending radius smaller than the minimum bending radius is used, it may result in mechanical damage or ground fault damage due to insulation breakdown. If it is necessary to use a bending radius smaller than the minimum bending radius, consult with your OMRON representative.

**Encoder Cables**

Model	Minimum bending radius (R)
R88A-CRGA□□□CR	45 mm
R88A-CRGA■ ■ ■ CR*1	50 mm
R88A-CRGB□□□CR	45 mm
R88A-CRGB■ ■ ■ CR*1	50 mm
R88A-CRGC□□□CR	45 mm
R88A-CRGC■ ■ ■ CR*1	50 mm

□□□: 003 to 020

■ ■ ■: 030 to 050

**Power Cables for Servomotors without Brakes**

Model	Minimum bending radius (R)
R88A-CAGA□□□SR	45 mm
R88A-CAGB□□□SR	90 mm
R88A-CAGC□□□SR	90 mm
R88A-CAGD□□□SR	100 mm

□□□: 003 to 050

**Power Cables for Servomotors with Brakes**

Model		Minimum bending radius (R)
R88A-CAGB□□□BR	Power cable	90 mm
	Brake Cables	45 mm
R88A-CAGC□□□BR	Power cable	90 mm
	Brake Cables	45 mm
R88A-CAGD□□□BR	Power cable	100 mm
	Brake Cables	45 mm

□□□: 003 to 050

### 3-4 Cable and Connector Specifications

#### Brake Cables

Model	Minimum bending radius (R)
R88A-CAGA□□□BR	45 mm

□□□: 003 to 050

#### Moving Bend Test

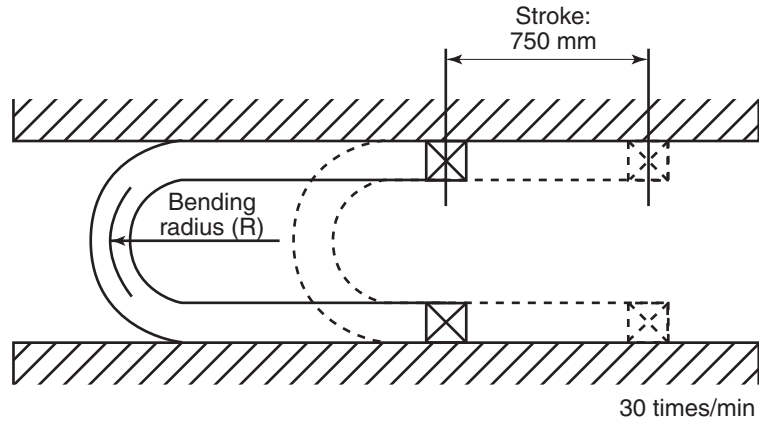

\*1. Encoder cable: 30 to 50 m only  
Stroke: 550 mm, 50 times/min

## Communications Cable Specifications

### ■ Computer Monitor Cable

#### Cable Models

Cables for RS-232 Communications

Model	Length (L)	Outer diameter of sheath	Weight
R88A-CCG002P2	2 m	4.2 dia.	Approx. 0.1 kg

#### Connection Configuration and Dimensions

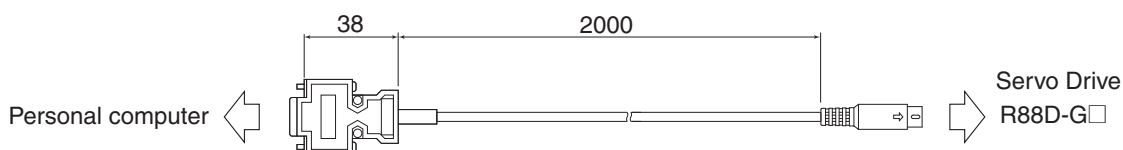

#### Wiring

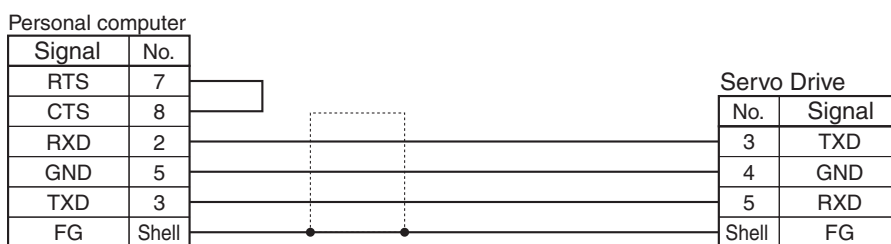

PC Connector

17JE-13090-02 (D8A) (DDK Ltd.)

#### Precautions for Correct Use

- Communications with the Host Device

After confirming the startup of the Servo Drive, initiate communications with the host device.

Note that irregular signals may be received from the host interface during startup. For this reason, take appropriate initialization measures such as clearing the receive buffer.

## 3-4 Cable and Connector Specifications

### ■ Communications Cables

#### Cable Models

Cables for RS-485 Communications

Model	Length (L)	Outer diameter of sheath	Weight
R88A-CCG0R5P4	0.5 m	4.2 dia.	Approx. 0.1 kg
R88A-CCG001P4	1 m		

#### Connection Configuration and Dimensions

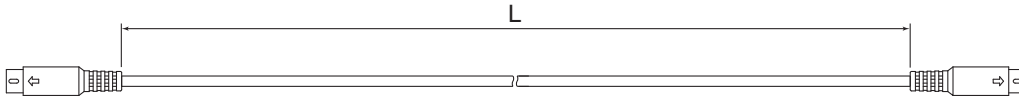

#### Wiring

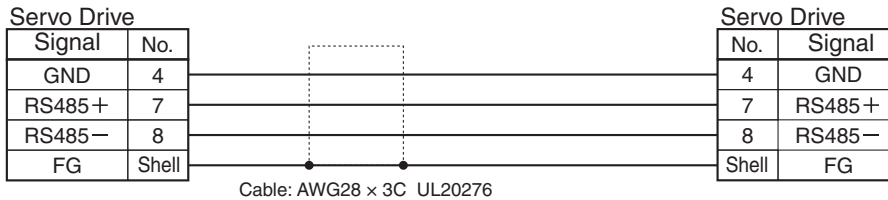

## Connector Specifications

### ■ Control I/O Connector (R88A-CNU11C)

This connector connects to the control I/O connector (CN1) on the Servo Drive.  
Use this connector when preparing a control cable yourself.

#### Dimensions

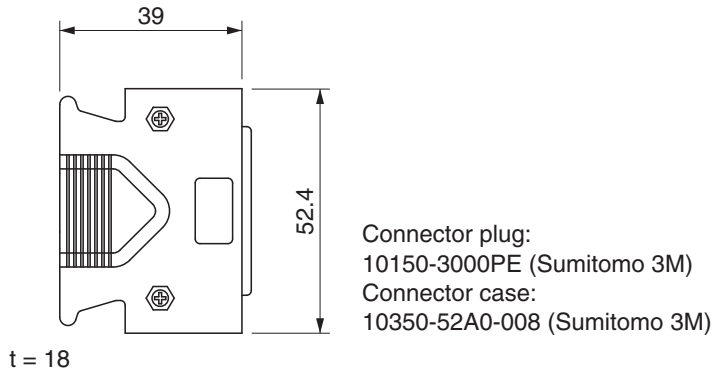

### ■ Encoder Connectors

These connectors are used for encoder cables.  
Use them when preparing an encoder cable yourself.

#### Dimensions

R88A-CNW01R (for Servo Drive's CN2 Connector)

This connector is a soldering type.  
Use the following cable.

- Applicable wire: AWG16 max.
- Insulating cover outer diameter: 2.1 mm dia. max.
- Outer diameter of sheath: 6.7 dia.  $\pm 0.5$  mm

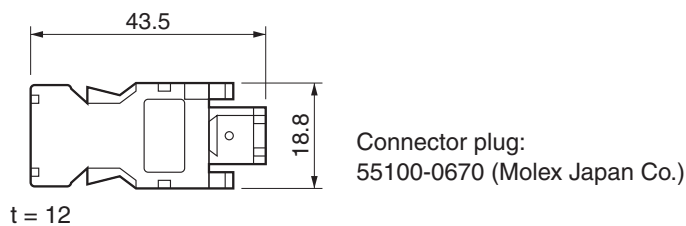

### 3-4 Cable and Connector Specifications

#### R88A-CNG01R (for Servomotor Connector) **ABS**

Use the following cable.

- Applicable wire: AWG22 max.
- Outer diameter of sheath: 1.75mm dia. max.

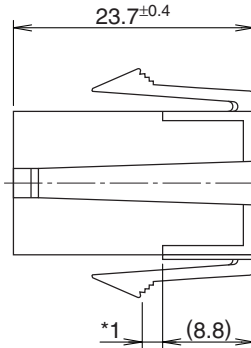
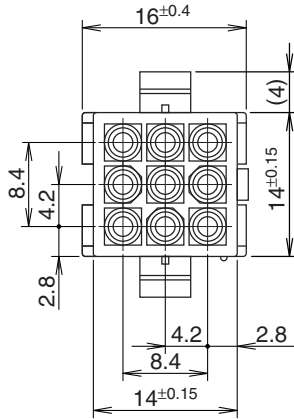

#### Panel Mounting Hole

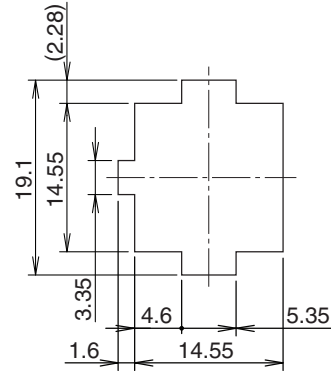

\*1. Applicable panel thickness:  
0.8 to 2.0 mm

Connector housing:  
172161-1 (Tyco Electronics AMP KK)  
Contact socket:  
170365-1 (Tyco Electronics AMP KK)

#### R88A-CNG02R (for Servomotor Connector) **INC**

Use the following cable.

- Applicable wire: AWG22 max.
- Outer diameter of sheath: 1.75 mm dia. max.

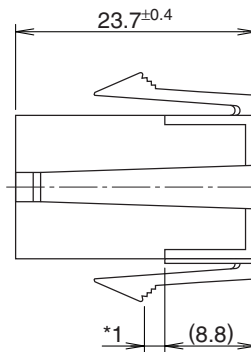
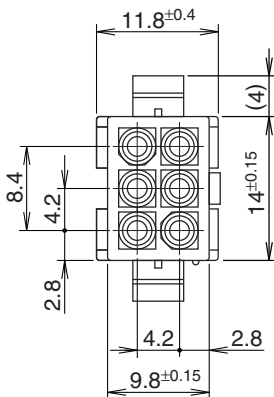

#### Panel Mounting Hole

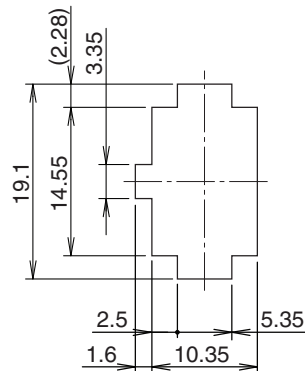

\*1. Applicable panel thickness:  
0.8 to 2.0 mm

Connector housing:  
172160-1 (Tyco Electronics AMP KK)  
Contact socket:  
170365-1 (Tyco Electronics AMP KK)

■ Power Cable Connector (R88A-CNG01A)

This connector is used for power cables.  
Use it when preparing a power cable yourself.

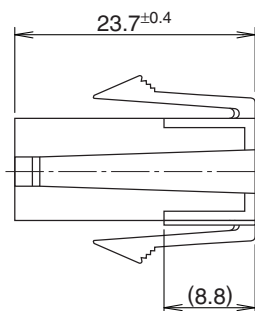
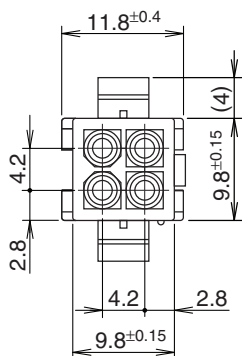

Panel Mounting Hole

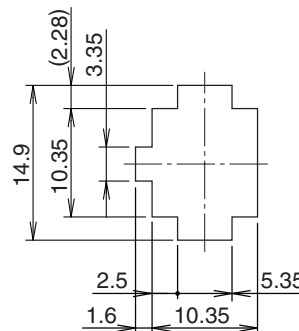

Connector housing:  
172159-1 (Tyco Electronics AMP KK)  
Contact socket:  
170366-1 (Tyco Electronics AMP KK)

Applicable panel thickness:  
0.8 to 2.0 mm

■ Brake Cable Connector (R88A-CNG01B)

This connector is used for brake cables.  
Use it when preparing a brake cable yourself.

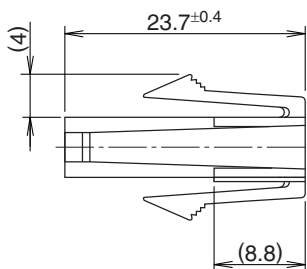
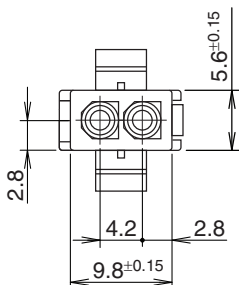

Panel Mounting Hole

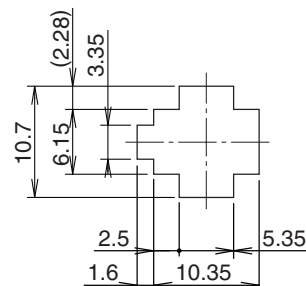

Connector housing:  
172157-1 (Tyco Electronics AMP KK)  
Contact socket:  
170366-1 (Tyco Electronics AMP KK)

Applicable panel thickness:  
0.8 to 2.0 mm

## Control Cable Specifications

### ■ Motion Control Unit Cables (R88A-CPG□M□)

Use this cable to connect to the Motion Control Units in OMRON SYSMAC Programmable Controllers. Cables are available for either one axis or two axes.

The following Motion Control Units can be used.

CS1W-MC221/421(-V1)

#### Cable Models

• Cables for One Axis

Model	Length (L)	Outer diameter of sheath	Weight
R88A-CPG001M1	1 m	8.3 dia.	Approx. 0.2 kg
R88A-CPG002M1	2 m		Approx. 0.3 kg
R88A-CPG003M1	3 m		Approx. 0.4 kg
R88A-CPG005M1	5 m		Approx. 0.6 kg

• Cables for Two Axes

Model	Length (L)	Outer diameter of sheath	Weight
R88A-CPG001M2	1 m	8.3 dia.	Approx. 0.3 kg
R88A-CPG002M2	2 m		Approx. 0.5 kg
R88A-CPG003M2	3 m		Approx. 0.7 kg
R88A-CPG005M2	5 m		Approx. 1.0 kg

#### Connection Configuration and Dimensions

• Cables for One Axis

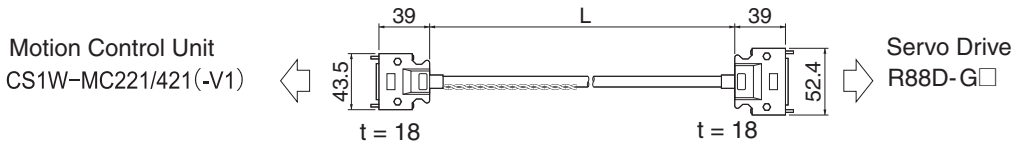

• Cables for Two Axes

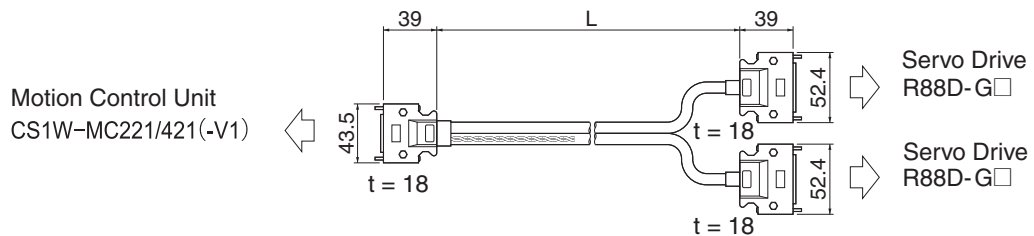



Wiring

- Cables for One Axis

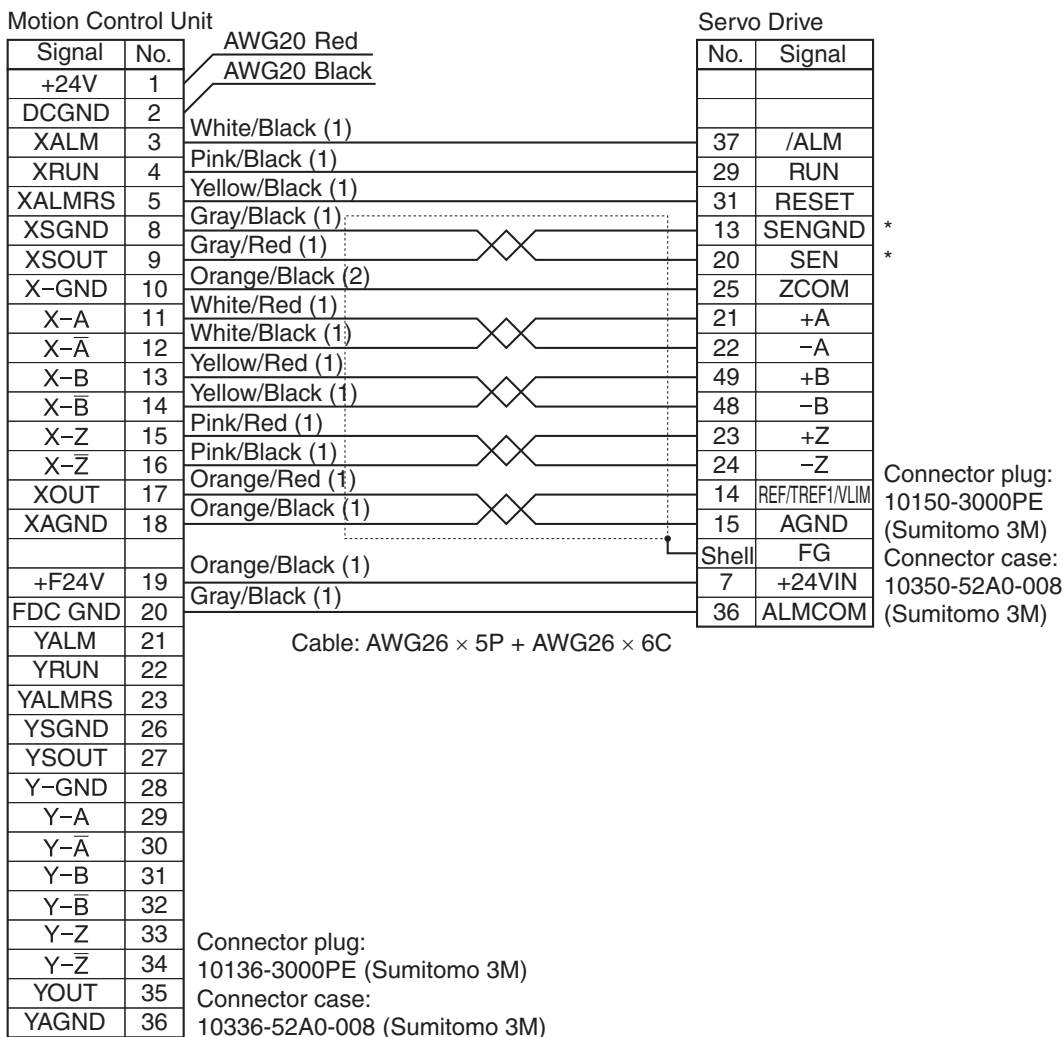

- The Motion Control Unit signals are the DRVX and DRVY connector signals. For the DRVZ and DRVU connectors, X and Y are indicated as Z and U, respectively.
- Pins marked with asterisks are for absolute encoders.
- Connect 24 VDC to the two lines (red and black) extending from the Motion Control Unit connector (red: +24 V, black: -).

### 3-4 Cable and Connector Specifications

• Cables for Two Axes

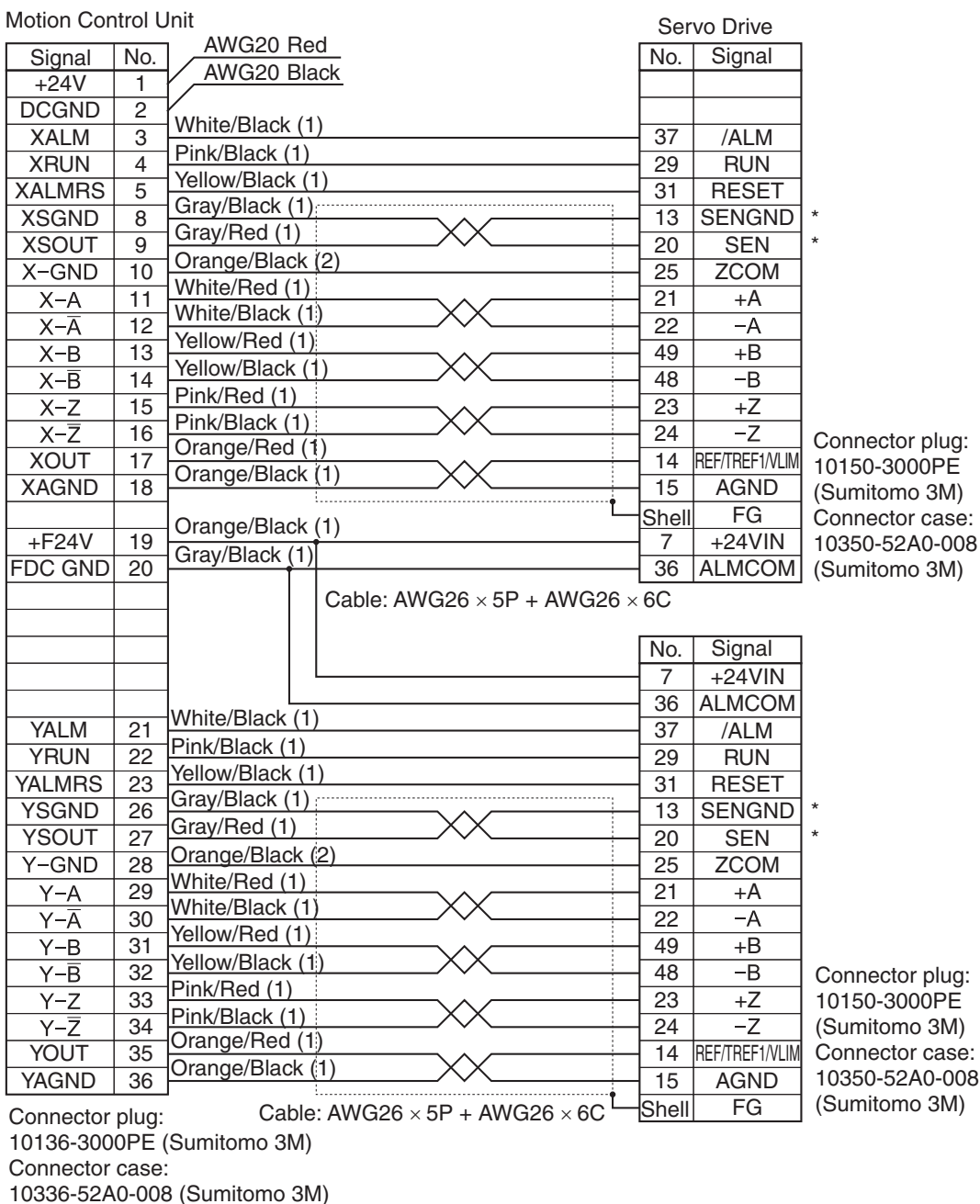

- The Motion Control Unit signals are the DRVX and DRVY connector signals. For the DRVZ and DRVU connectors, X and Y are indicated as Z and U, respectively.
- Pins marked with asterisks are for absolute encoders.
- Connect 24 VDC to the two lines (red and black) extending from the Motion Control Unit connector (red: +24 V, black: -).

■ General-purpose Control Cables (R88A-CPG□S)

A General-purpose Control Cable connects to the Servo Drive's control I/O connector (CN1). The connector for the controller is not provided. When connecting to a Position Control Unit which doesn't have a specified cable or connecting to another company's controller, prepare wiring suited for the controller to be connected.

- When connecting to a controller which doesn't have a specified cable, either use a General-purpose Control Cable or a Connector Terminal Block Cable and a Connector Terminal Block.

Cable Models

Model	Length (L)	Outer diameter of sheath	Weight
R88A-CPG001S	1 m	12.8 dia.	Approx. 0.3 kg
R88A-CPG002S	2 m		Approx. 0.6 kg

Connection Configuration and Dimensions

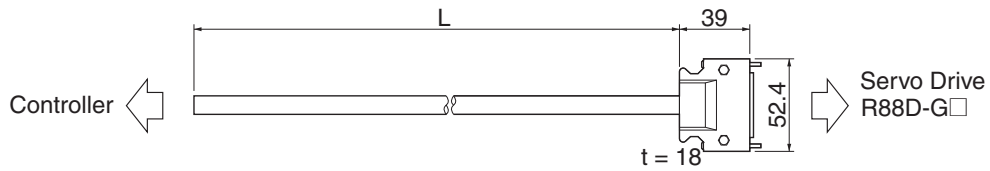

### 3-4 Cable and Connector Specifications

#### Wiring

No.	Wire/mark color	Signal	No.	Wire/mark color	Signal
1	Orange/Red (1)	+24VCW	27	Pink/Black (3)	GSEL/TLSEL
2	Orange/Black (1)	+24VCCW	28	White/Black (3)	GESEL/VSEL3
3	Gray/Red (1)	+CW/+PULS/+FA	29	Yellow/Red (3)	RUN
4	Gray/Black (1)	-CW/-PULS/-FA	30	Pink/Red (3)	ECRST/VSEL2
5	White/Red (1)	+CCW/+SIGN/+FB	31	Yellow/Black (3)	RESET
6	White/Black (1)	-CCW/-SIGN/-FB	32	Gray/Black (4)	TVSEL
7	Yellow/Red (1)	+24VIN	33	Orange/Red (4)	IPG/VSEL1
8	Pink/Red (1)	NOT	34	White/Red (4)	READYCOM
9	Pink/Black (1)	POT	35	White/Black (4)	READY
10	Orange/Red (2)	BKIRCOM	36	Yellow/Red (4)	ALMCOM
11	Orange/Black (2)	BKIR	37	Yellow/Black (4)	/ALM
12	Yellow/Black (1)	OUTM1	38	Pink/Red (4)	INPCOM/TGONCOM
13	Gray/Black (2)	GND	39	Pink/Black (4)	INP/TGON
14	White/Red (2)	REF/TREF1/VLIM	40	Gray/Red (4)	OUTM2
15	White/Black (2)	AGND	41	Orange/Black (4)	COM
16	Yellow/Red (2)	PCL/TREF2	42	Gray/Red (5)	BAT
17	Yellow/Black (2), Pink/Black (2)	AGND	43	Gray/Black (5)	BATGND
18	Pink/Red (2)	NCL	44	White/Red (5)	+CWLD
19	Orange/Red (5)	Z	45	White/Black (5)	-CWLD
20	Gray/Red (2)	SEN	46	Yellow/Red (5)	+CCWLD
21	Orange/Red (3)	+A	47	Yellow/Black (5)	-CCWLD
22	Orange/Black (3)	-A	48	Pink/Black (5)	-B
23	Gray/Red (3)	+Z	49	Pink/Red (5)	+B
24	Gray/Black (3)	-Z	50	---	---
25	Orange/Black (5)	ZCOM	Shell	---	FG
26	White /Red (3)	VZERO/DFSEL/ PNSEL			

Connector plug: 10150-3000PE (Sumitomo 3M)

Connector case: 10350-52A0-008 (Sumitomo 3M)

Cable: AWG24 × 25P UL20276

- Wires with the same wire color and the same number of marks form a twisted pair.  
Example: An orange/red (1) wire and orange/black (1) wire form are a twisted pair.

#### ■ Connector Terminal Block Cables (XW2Z-□J-B24)

This Cable is for the connector terminal block of the Servo Drive's control I/O connector (CN1). All of the pins in the control I/O connector (CN1) can be converted to terminals on the terminal block.

#### Cable Models

Model	Length (L)	Outer diameter of sheath	Weight
XW2Z-100J-B24	1 m	11.2 dia.	Approx. 0.2 kg
XW2Z-200J-B24	2 m		Approx. 0.4 kg

#### Connection Configuration and Dimensions

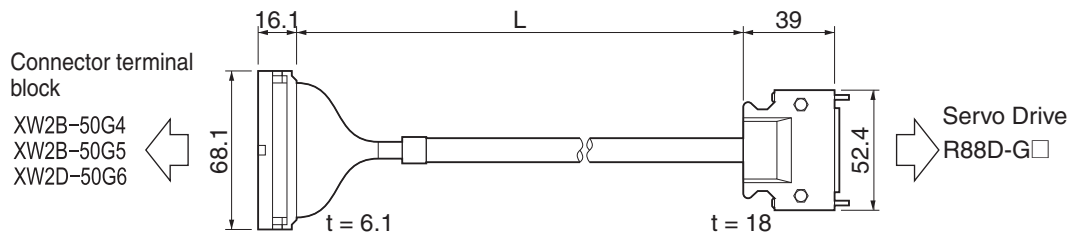

### 3-4 Cable and Connector Specifications

Terminal block		Connector	Servo Drive		
No.	No.		No.	Wire/mark color	Signal
1	1		1	Blue/Red (1)	+24VCW
2	2		2	Blue/Black (1)	+24VCCW
3	3		3	Pink/Red (1)	+CW/+PULS/+FA
4	4		4	Pink/Black (1)	CW/ PULS/ -FA
5	5		5	Green/Red (1)	+CCW/+SIGN/+FB
6	6		6	Green/Black (1)	CCW/ SIGN/ -FB
7	7		7	Orange/Red (1)	+24VIN
8	8		8	Gray/Red (1)	NOT
9	9		9	Gray/Black (1)	POT
10	10		10	Blue/Red (2)	BKIRCOM
11	11		11	Blue/Black (2)	BKIR
13	13		13	Pink/Red (2)	SENGND
20	20		20	Pink/Black (2)	SEN
14	14		14	Green/Red (2)	REF/TREF1/VLIM
15	15		15	Green/Black (2)	AGND
16	16		16	Orange/Red (2)	PCL/TREF2
17	17		17	Orange/Black (2)	AGND
18	18		18	Gray/Red (2)	NCL
12	12		12	Gray/Black (2)	OUTM1
19	19		19	Blue/Red (3)	Z
25	25		25	Blue/Black (3)	ZCOM
21	21		21	Pink/Red (3)	+A
22	22		22	Pink/Black (3)	A
23	23		23	Green/Red (3)	+Z
24	24		24	Green/Black (3)	Z
26	26		26	Orange/Red (3)	VZERO/DFSEL/PNSEL
27	27		27	Orange/Black (3)	GSEL/TLSEL
28	28		28	Gray/Red (3)	GESEL/VSEL3
29	29		29	Gray/Black (3)	RUN
30	30		30	Blue/Red (4)	ECRST/VSEL2
31	31		31	Blue/Black (4)	RESET
32	32		32	Pink/Red (4)	TVSEL
33	33		33	Pink/Black (4)	IPG/VSEL1
34	34		34	Green/Red (4)	READYCOM
35	35		35	Green/Black (4)	READY
36	36		36	Orange/Red (4)	ALMCOM
37	37		37	Orange/Black (4)	/ALM
38	38		38	Gray/Red (4)	INPCOM/TGONCOM
39	39		39	Gray/Black (4)	INP/TGON
40	40		40	Blue/Red (5)	OUTM2
41	41		41	Blue/Black (5)	COM
42	42		42	Pink/Red (5)	BAT
43	43		43	Pink/Black (5)	BATGND
44	44		44	Green/Red (5)	+CWLD
45	45		45	Green/Black (5)	CWLD
46	46		46	Orange/Red (5)	+CCWLD
47	47		47	Orange/Black (5)	CCWLD
48	48		48	Gray/Red (5)	B
49	49		49	Gray/Black (5)	+B
50	50		50	Orange/Black (1)	-
			Shell		FG

Wires with the same wire color and the same number of marks form a twisted pair.

Example:  
A yellow/black (1) wire and pink/black (1) wire form a twisted pair.

Servo Drive Connector  
Connector plug:  
10150-3000PE (Sumitomo 3M)  
Connector case:  
10350-52A0-008 (Sumitomo 3M)

Terminal Block Connector  
Connector socket: XG4M-5030 (OMRON)  
Strain relief: XG4T-5004 (OMRON)

Cable  
AWG28 × 25P UL2464

■ Connector-Terminal Block Conversion Unit

The Connector-Terminal Block Conversion Unit can be used along with a Connector Terminal Block Cable (XW2Z-□J-B24) to convert the Servo Drive's control I/O connector (CN1) to a terminal block.

XW2B-50G4 (M3 screw terminal block)

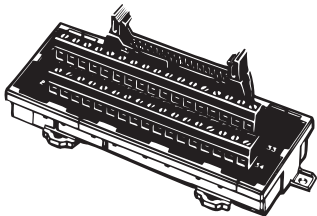

• Dimensions

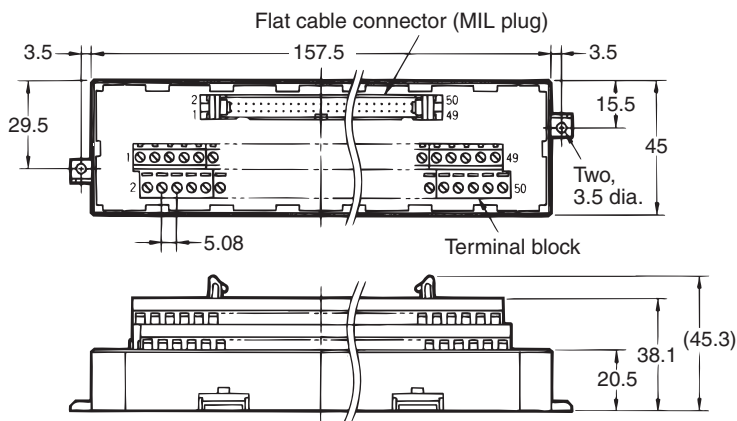

**Precautions for Correct Use**

- Use 0.30 to 1.25 mm<sup>2</sup> wire (AWG22 to AWG16).
- The wire inlet is 1.8 mm (height) × 2.5 mm (width).
- Strip the insulation from the end of the wire for 6 mm as shown below.

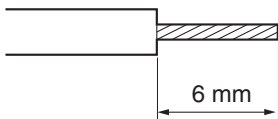

#### XW2B-50G5 (M3.5 Screw Terminal Block)

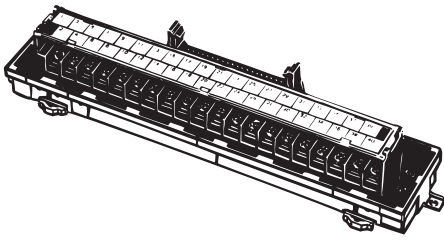

• Dimensions

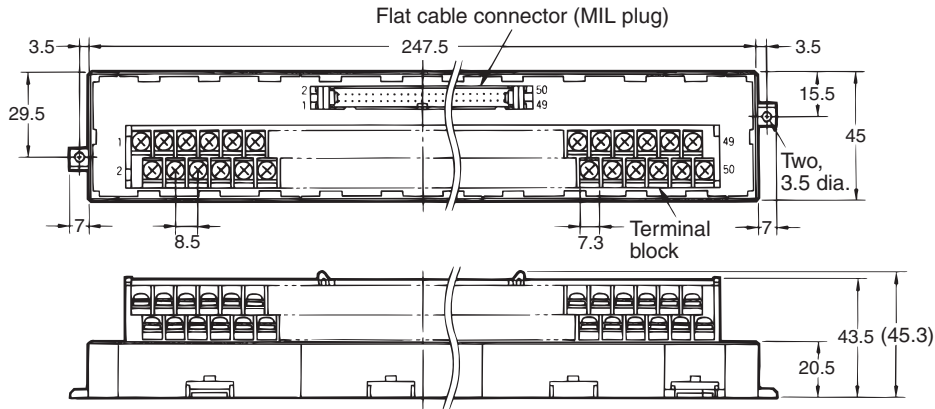

**Precautions for Correct Use**

- When using crimp terminals, use crimp terminals with the following dimensions.
- When connecting wires and crimp terminals to a terminal block, tighten them with a tightening torque of 0.59 N·m.

Round Crimp Terminals

Fork Terminals

3.7-mm dia.



Applicable Crimp Terminals		Applicable Wires
Round Crimp Terminals	1.25-3	AWG22-16 (0.3 to 1.25 mm <sup>2</sup> )
	2-3.5	AWG16-14 (1.25 to 2.0 mm <sup>2</sup> )
Fork Terminals	1.25Y-3	AWG22-16 (0.3 to 1.25 mm <sup>2</sup> )
	2-3.5	AWG16-14 (1.25 to 2.0 mm <sup>2</sup> )



**XW2D-50G6 (M3 Screw Terminal Block)**

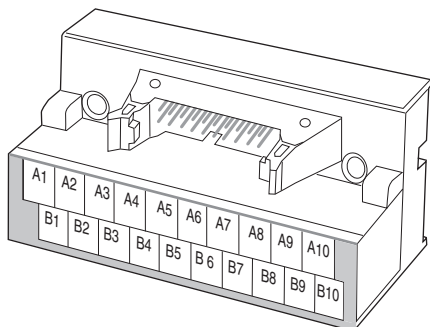

• Dimensions

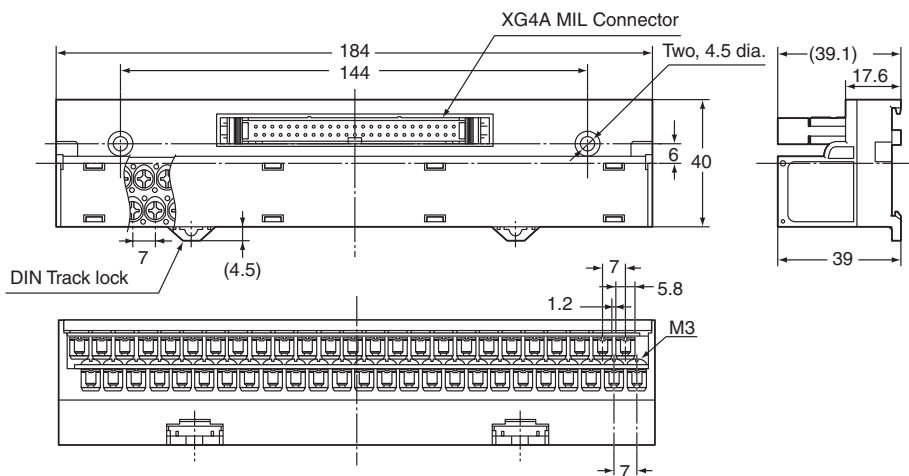

**Precautions for Correct Use**

- When using crimp terminals, use crimp terminals with the following dimensions.
- When connecting wires and crimp terminals to a terminal block, tighten them with a tightening torque of 0.7 N·m.

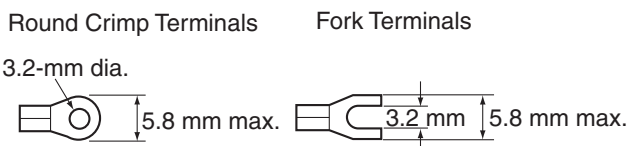

Applicable Crimp Terminals		Applicable Wires
Round Crimp Terminals	1.25-3	AWG22-16 (0.3 to 1.25 mm <sup>2</sup> )
Fork Terminals	1.25Y-3	AWG22-16 (0.3 to 1.25 mm <sup>2</sup> )

## 3-5 Servo Relay Units and Cable Specifications

This section provides the specifications for the Servo Relay Units and Cables used for connecting to Position Control Units for OMRON Programmable Controllers (SYSMAC). Select the models that match the Position Control Unit to be used.

### Servo Relay Units Specifications

#### ■ XW2B-20J6-1B

This Servo Relay Unit connects to the following OMRON Position Control Units.

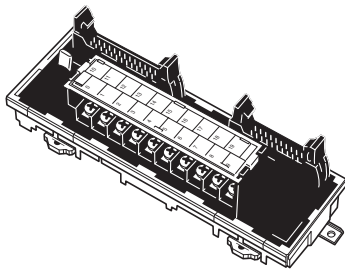

- CJ1W-NC113/-NC133
- CS1W-NC113/-NC133
- C200HW-NC113

#### Dimensions

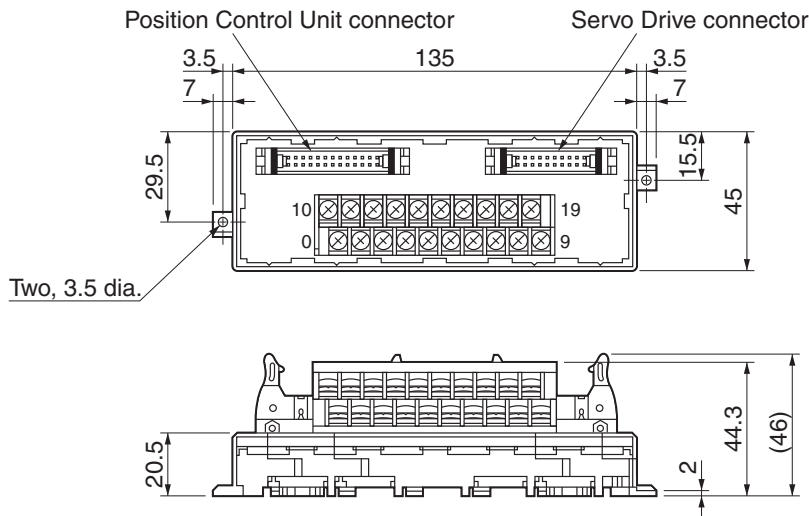

- Terminal Block pitch: 7.62 mm.

Wiring

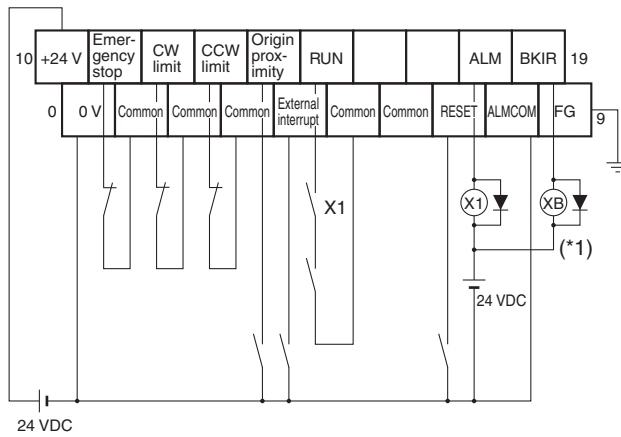

- \*1. The XB contacts are used to turn ON/OFF the electromagnetic brake.
- \*2. Do not connect unused terminals.
- \*3. The 0 V terminal is internally connected to the common terminals.
- \*4. The following crimp terminal is applicable: R1.25-3 (round with open end).

■ XW2B-40J6-2B

This Servo Relay Unit connects to the following OMRON Position Control Units.

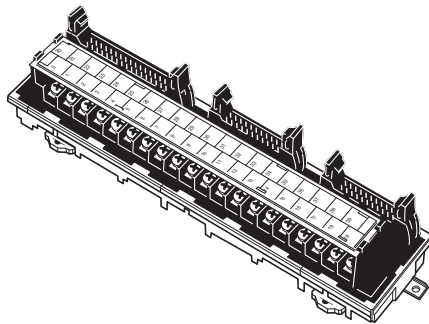

- CJ1W-NC213/-NC233/-NC413/-NC433
- CS1W-NC213/-NC233/-NC413/-NC433
- C200HW-NC213/-NC413

Dimensions

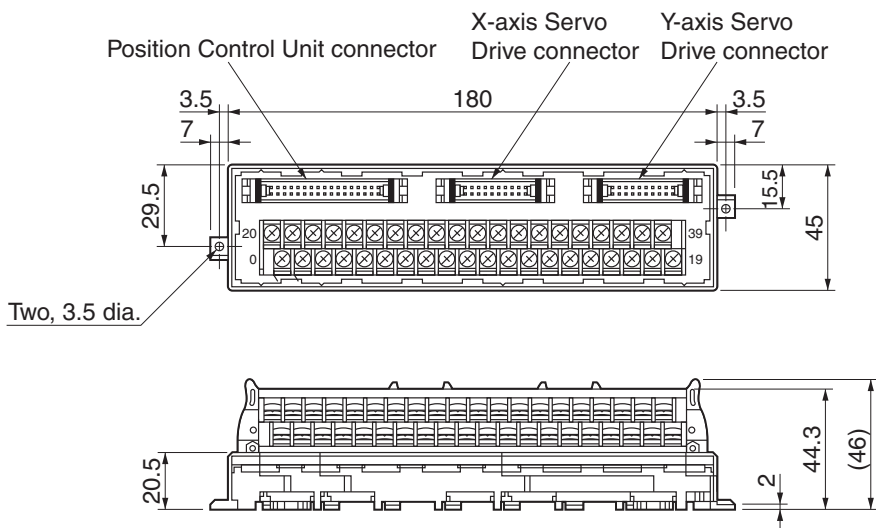

- Terminal Block pitch: 7.62 mm

### 3-5 Servo Relay Units and Cable Specifications

#### Wiring

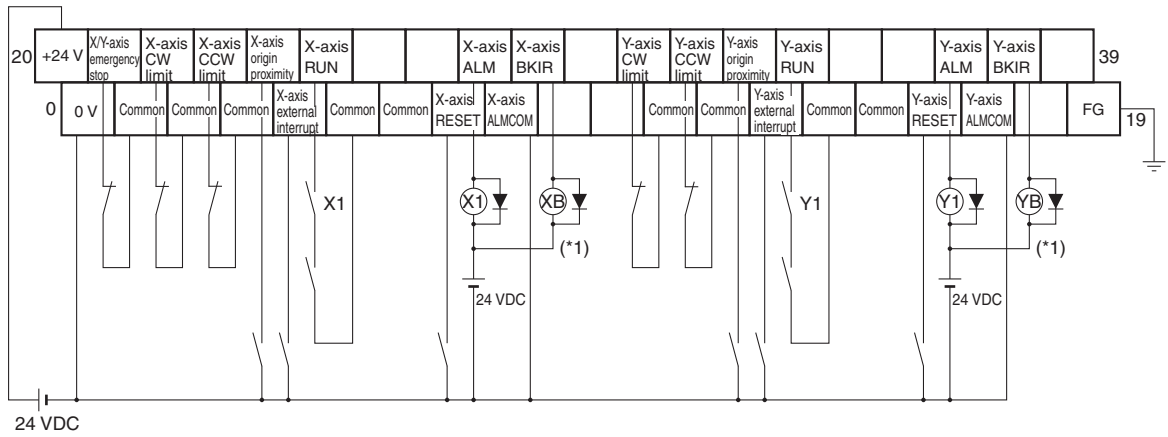

- \*1. The XB contacts and YB contacts are used to turn ON/OFF the electromagnetic brake.
- \*2. Do not connect unused terminals.
- \*3. The 0 V terminal is internally connected to the common terminals.
- \*4. The following crimp terminal is applicable: R1.25-3 (round with open end).

#### ■ XW2B-20J6-3B

This Servo Relay Unit connects to the following OMRON Programmable Controller.

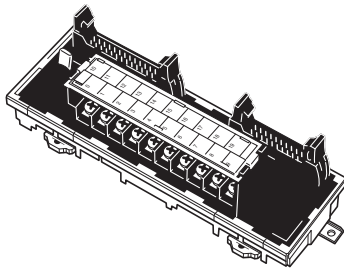

• CQM1-CPU43-V1

#### Dimensions

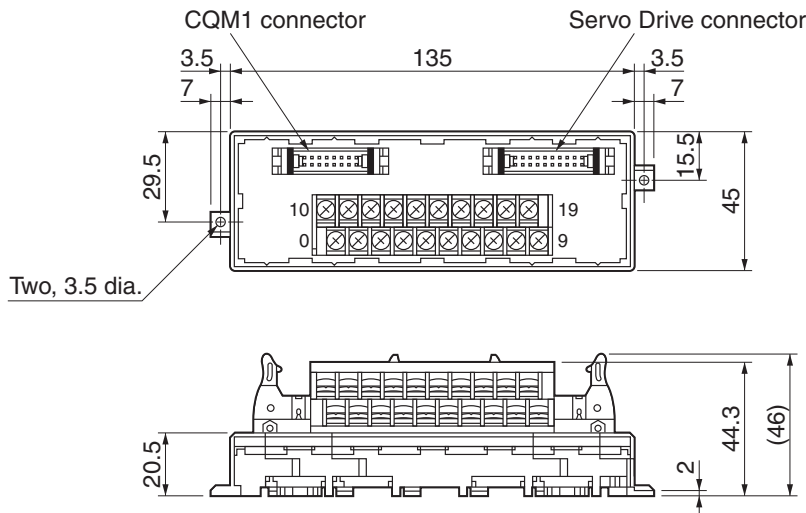

• Terminal Block pitch: 7.62 mm.

#### Wiring

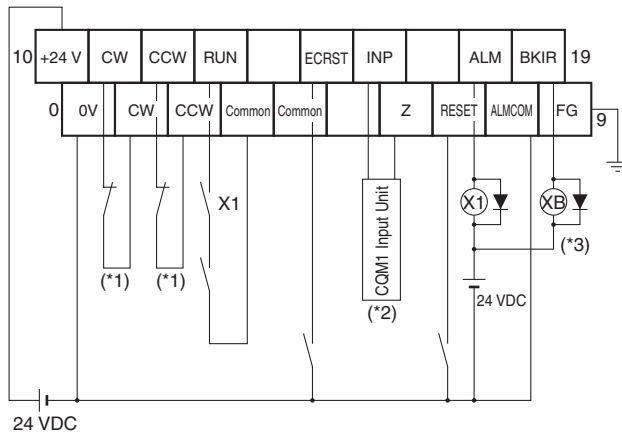

- \*1. If this signal is input, the output pulse from the CQM1 will be input to the high-speed counter.
- \*2. Input this output signal to a CQM1 Input Unit.
- \*3. The XB contacts are used to turn ON/OFF the electromagnetic brake.
- \*4. The phase-Z output is an open-collector output.
- \*5. Do not connect unused terminals.
- \*6. The 0 V terminal is internally connected to the common terminals.
- \*7. The following crimp terminal is applicable: R1.25-3 (round with open end).

### 3-5 Servo Relay Units and Cable Specifications

#### ■ XW2B-20J6-8A

This Servo Relay Unit connects to the following OMRON Programmable Controllers.

- CJ1M-CPU21/-CPU22/-CPU23 (for 1 axis)

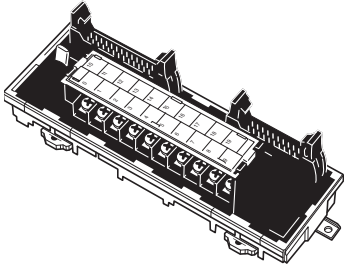

#### Dimensions

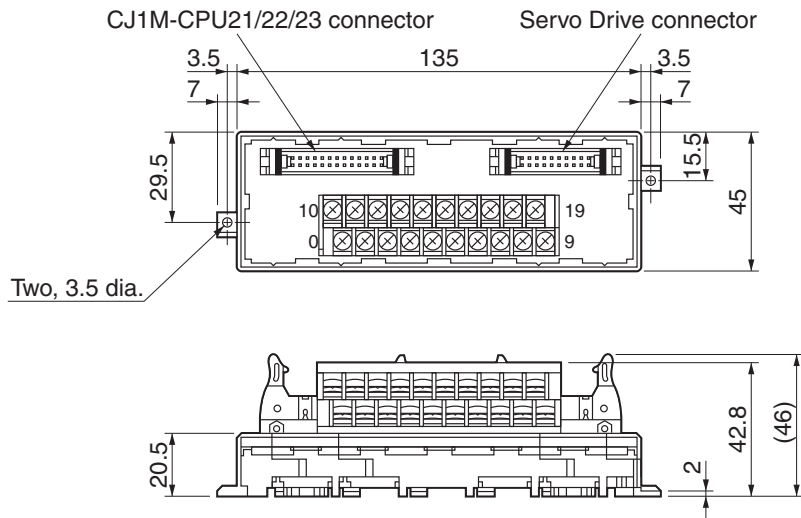

- Terminal Block pitch: 7.62 mm.

#### Wiring

The Servo Drive phase-Z output signal is wired to the origin proximity signal in this Terminal Block.

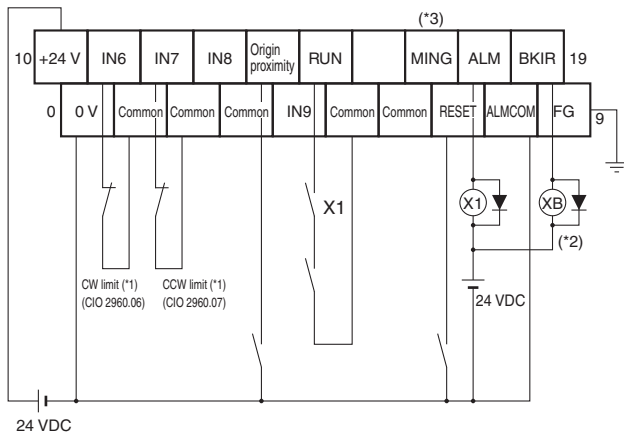

\*1. CW and CCW limit input signals can also be input through Input Units. The bits for the CW/CCW limit inputs in the CJ1M are as follows: CW: A540.08, CCW: A540.09 for pulse output 0 and CW: A541.08, CCW: A541.09 for pulse output 1. For example, the flag for the CW limit input (A540.08) can be controlled with an output from the ladder diagram using a bit allocated to the actual input (CIO 2960.06) on the Input Unit, as shown below.

Example:



- \*2. The XB contacts are used to turn ON/OFF the electromagnetic brake.
- \*3. Connection to the MING input terminal is invalid.
- \*4. Do not connect unused terminals.
- \*5. The 0 V terminal is internally connected to the common terminals.
- \*6. The following crimp terminal is applicable: R1.25-3 (round with open end).

### 3-5 Servo Relay Units and Cable Specifications

#### ■ XW2B-40J6-9A

This Servo Relay Unit connects to the following OMRON Programmable Controllers.

- CJ1M-CPU21/-CPU22/-CPU23 (for 2 axes)

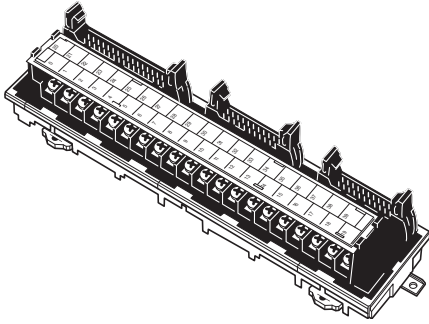

#### Dimensions

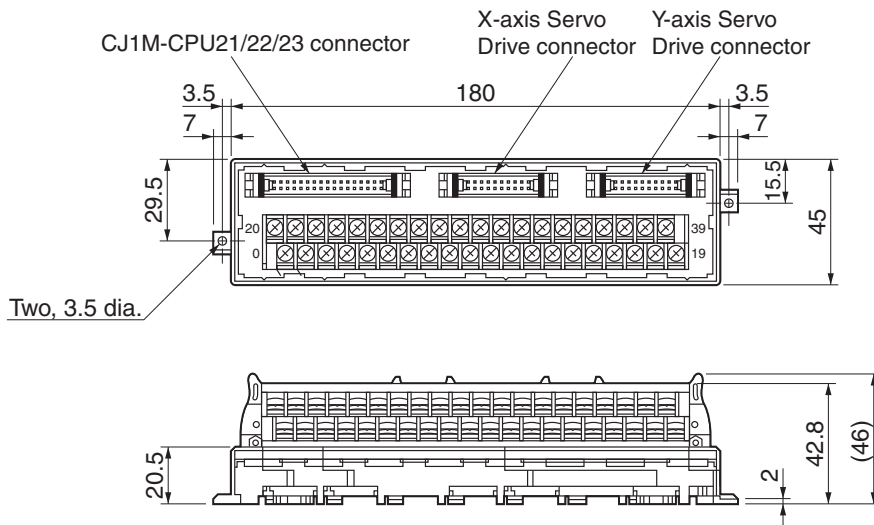

- Terminal Block pitch: 7.62 mm.



#### Wiring

The Servo Drive phase-Z output signal is wired to the origin proximity signal in this Terminal Block.

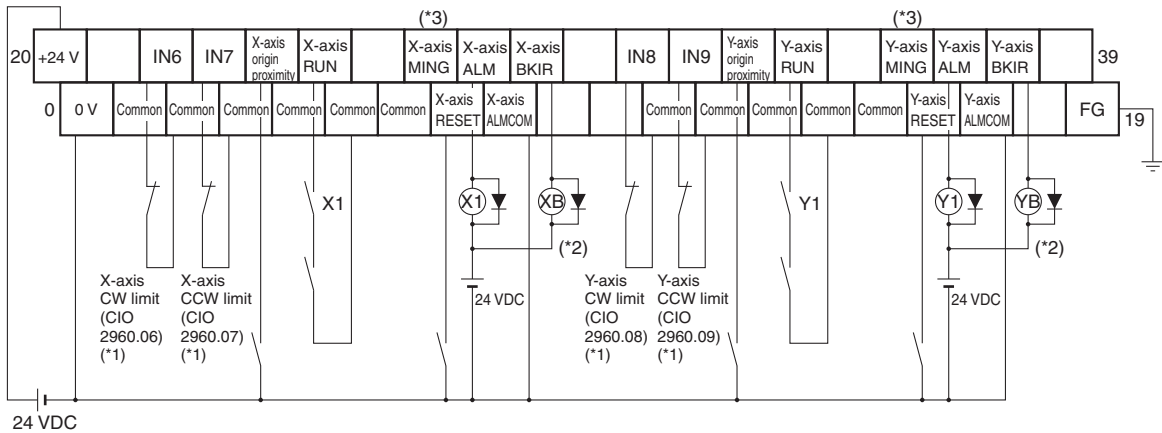

\*1. CW and CCW limit input signals can also be input through Input Units. The bits for the CW/CCW limit inputs in the CJ1M are as follows: CW: A540.08, CCW: A540.09 for pulse output 0 and CW: A541.08, CCW: A541.09 for pulse output 1. For example, the flag for the CW limit input (A540.08) can be controlled with an output from the ladder diagram using a bit allocated to the actual input (CIO 2960.06) on the Input Unit, as shown below.

Example:



- \*2. The XB and YB contacts are used to turn ON/OFF the electromagnetic brake.
- \*3. Connection to the MING input terminal is invalid.
- \*4. Do not connect unused terminals.
- \*5. The 0 V terminal is internally connected to the common terminals.
- \*6. The following crimp terminal is applicable: R1.25-3 (round with open end).

### 3-5 Servo Relay Units and Cable Specifications

#### ■ XW2B-80J7-12A

This Servo Relay Unit connects to the following OMRON Programmable Controllers.

- FQM1-MMA22
- FQM1-MMP22

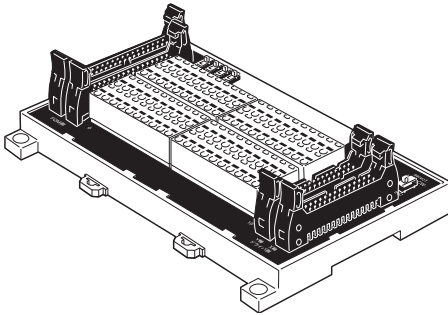

#### Dimensions

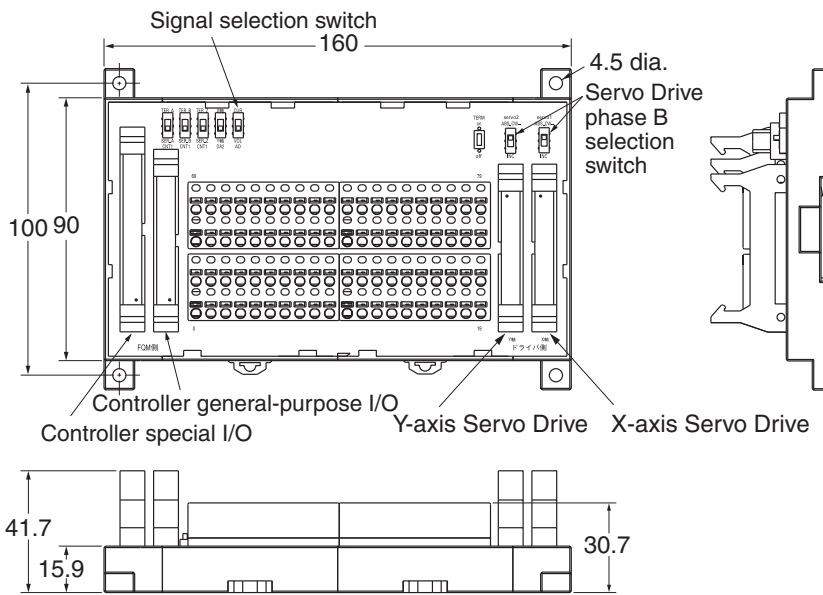

System Configuration Example for the FQM1

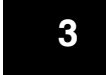
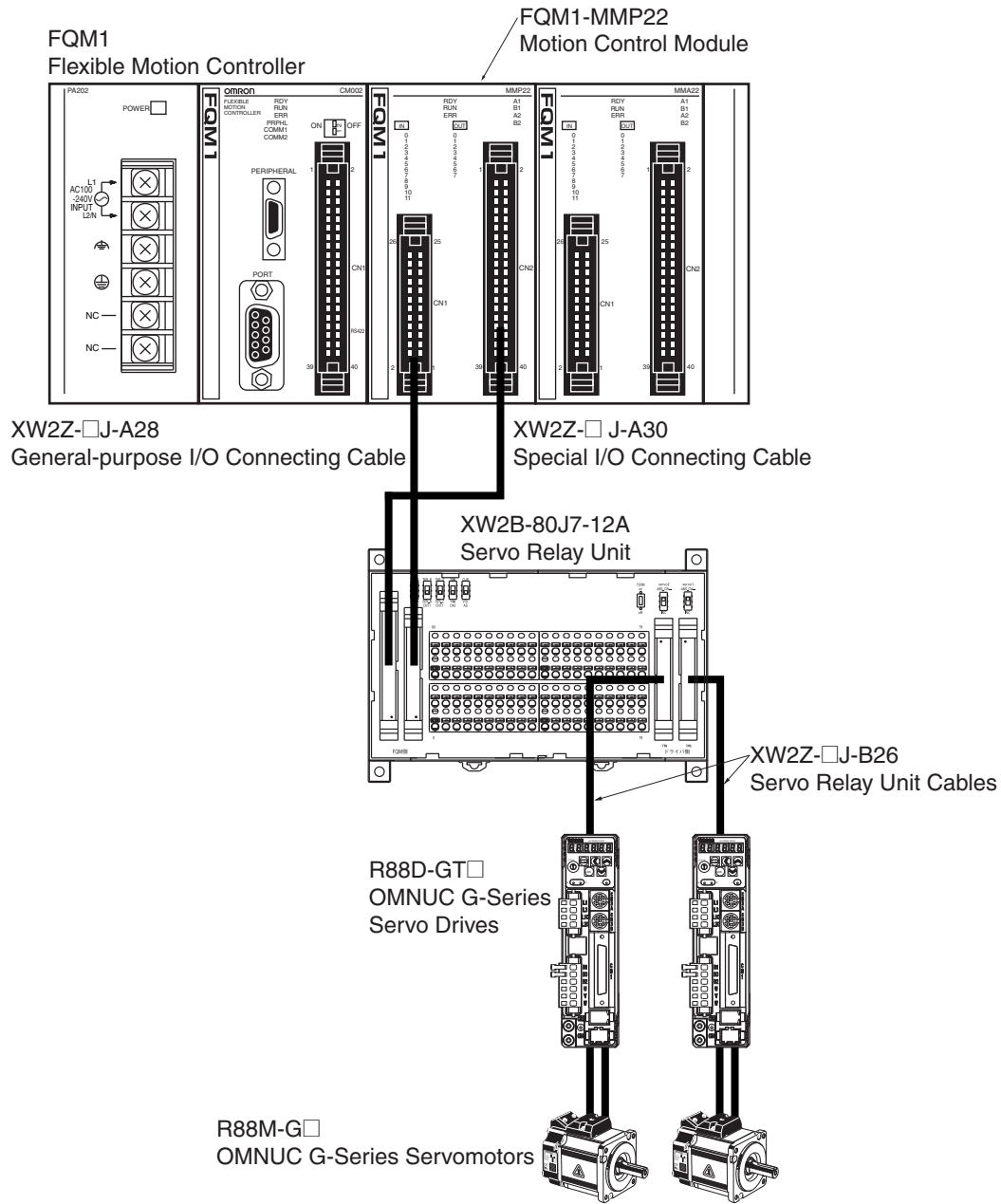

Terminal Block Connection

- The terminal block signal names are different depending on the Controller to be connected.
- A total of 80 terminals are provided (terminal numbers 0 to 79).
- Signal names and standard connections are listed in the following table.

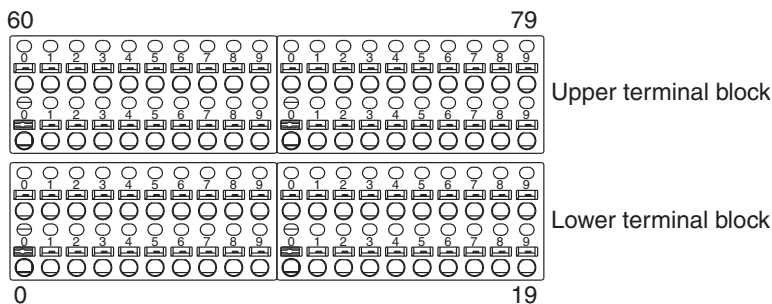

#### FQM1-MMA22 Signal Names

No.	60	61	62	63	64	65	66	67	68	69	70	71	72	73	74	75	76	77	78	79
Signal name	5 V (*1)	Latch signal 1 input	Latch signal 2 input	Servo #1 phase-A LD+	Servo #1 phase-B LD+	Servo #1 phase-Z LD+	Voltage input (+)	Servo #1 ALM	Servo #1 BKIR	IN4	IN5	IN6	IN7	-	Servo #1 RUN	Servo #1 RESET	Servo #1 ECRST	Servo #1 GSEL/TLSEL	-	-
No.	40	41	42	43	44	45	46	47	48	49	50	51	52	53	54	55	56	57	58	59
Signal name	0 V	Latch signal 1 common (0 V)*5	Latch signal 2 common (0 V)*5	Servo #1 phase-A LD-	Servo #1 phase-B LD-	Servo #1 phase-Z LD-	Voltage input (-)	Servo #1 READY	Common (0 V)*4	IN4 Common (0 V)*4	IN5 Common (0 V)*4	IN6 Common (0 V)*4	IN7 Common (0 V)*4	-	OUT0	OUT1	OUT2	OUT3	-	-

No.	20	21	22	23	24	25	26	27	28	29	30	31	32	33	34	35	36	37	38	39
Signal name	+24 V *2	+24 V *3	IN0	IN1	IN2	IN3	-	Servo #2 ALM	Servo #2 BKIR	IN8	IN9	IN10	IN11	-	Servo #2 RUN	Servo #2 RESET	Servo #2 ECRST	Servo #2 GSEL/TLSEL	-	FG
No.	0	1	2	3	4	5	6	7	8	9	10	11	12	13	14	15	16	17	18	19
Signal name	0 V	0 V	IN0 Common (0 V)*5	IN1 Common (0 V)*5	IN2 Common (0 V)*5	IN3 Common (0 V)*5	-	Servo #2 READY	Common (0 V)*4	IN8 Common (0 V)*4	IN9 Common (0 V)*4	IN10 Common (0 V)*4	IN11 Common (0 V)*4	-	OUT4	OUT5	OUT6	OUT7	-	FG

\*1. Use as a power supply for FQM1-MMA22 pulse outputs, or as a power supply for the SEN output for an Absolute Encoder Servo Drive.

\*2. Use as a power supply for IN4 to IN11, OUT0 to OUT7, or Servo Drive control signals.

\*3. Use as a power supply for IN0 to IN3 (interrupt inputs) or latch inputs.

\*4. Connected to 0 V at pin 0.

\*5. Connected to 0 V at pin 1.

**FQM1-MMP22 Signal Names**

No.	60	61	62	63	64	65	66	67	68	69	70	71	72	73	74	75	76	77	78	79
Signal name	5 V (*1)	Latch signal 1 input	Latch signal 2 input	Servo #1 phase-A LD+	Servo #1 phase-B LD+	Servo #1 phase-Z LD+	-	Servo #1 ALM	Servo #1 BKIR	IN4	IN5	IN6	IN7	-	Servo #1 RUN	Servo #1 RESET	Servo #1 ECRST	Servo #1 GSEL/TLSEL	-	-
No.	40	41	42	43	44	45	46	47	48	49	50	51	52	53	54	55	56	57	58	59
Signal name	0 V	Latch signal 1 common (0 V) <sup>*5</sup>	Latch signal 2 common (0 V) <sup>*5</sup>	Servo #1 phase-A LD-	Servo #1 phase-B LD-	Servo #1 phase-Z LD-	-	Servo #1 INP	Common (0 V) <sup>*4</sup>	IN4 Common (0 V) <sup>*4</sup>	IN5 Common (0 V) <sup>*4</sup>	IN6 Common (0 V) <sup>*4</sup>	IN7 Common (0 V) <sup>*4</sup>	-	OUT0	OUT1	OUT2	OUT3	-	-

No.	20	21	22	23	24	25	26	27	28	29	30	31	32	33	34	35	36	37	38	39
Signal name	+24 V *2	+24 V *3	IN0	IN1	IN2	IN3	-	Servo #2 ALM	Servo #2 BKIR	IN8	IN9	IN10	IN11	-	Servo #2 RUN	Servo #2 RESET	Servo #2 ECRST	Servo #2 GSEL/TLSEL	-	FG
No.	0	1	2	3	4	5	6	7	8	9	10	11	12	13	14	15	16	17	18	19
Signal name	0 V	0 V	IN0 Common (0 V) <sup>*5</sup>	IN1 Common (0 V) <sup>*5</sup>	IN2 Common (0 V) <sup>*5</sup>	IN3 Common (0 V) <sup>*5</sup>	-	Servo #2 INP	Common (0 V) <sup>*4</sup>	IN8 Common (0 V) <sup>*4</sup>	IN9 Common (0 V) <sup>*4</sup>	IN10 Common (0 V) <sup>*4</sup>	IN11 Common (0 V) <sup>*4</sup>	-	OUT4	OUT5	OUT6	OUT7	-	FG

- \*1. Use as a power supply for FQM1-MMP22 pulse outputs, or as a power supply for the SEN output for an Absolute Encoder Servo Drive.
- \*2. Use as a power supply for IN4 to IN11, OUT0 to OUT7, or Servo Drive control signals.
- \*3. Use as a power supply for IN0 to IN3 (interrupt inputs) or latch inputs.
- \*4. Connected to 0 V at pin 0.
- \*5. Connected to 0 V at pin 1.

### 3-5 Servo Relay Units and Cable Specifications

#### Wiring Example

Servo Drive signals			FQM1 signals			
	#1	#2	For Servo Drive #1		For Servo Drive #2	
RUN	74	34	54	OUT0	14	OUT4
ECRST	76	36	56	OUT2	16	OUT6
INP	47	7	69	IN4	29	IN8
/ALM	67	27	70	IN5	30	IN9
BKIR	68	28	71	IN6	31	IN10

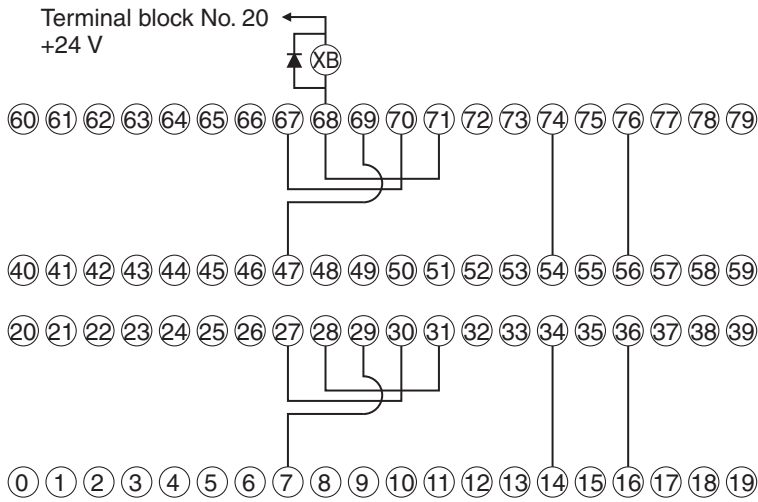

## Servo Drive-Servo Relay Unit Cable Specifications

### ■ Servo Drive Cable (XW2Z-□J-B25)

This Cable connects the Servo Drive to a Servo Relay Unit (XW2B-20J6-1B/-3B, XW2B-40J6-2B).

#### Cable Models

Model	Length (L)	Outer diameter of sheath	Weight
XW2Z-100J-B25	1 m	8.1 dia.	Approx. 0.1 kg
XW2Z-200J-B25	2 m		Approx. 0.2 kg

**Note** Do not use a Servo Relay Unit Cable for line receiver inputs (+CWLD: CN1 pin 44, -CWLD: CN1 pin 45, +CCWLD: CN1 pin 46, -CCWLD: CN1 pin 47).  
Use a General-purpose Control Cable (R88A-CPG□S) and prepare wiring suited for the controller to be connected.

#### Connection Configuration and Dimensions

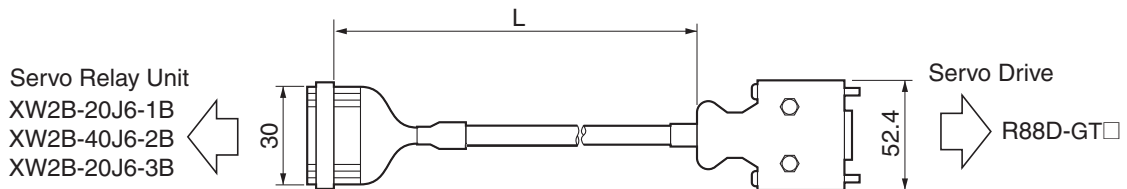

#### Wiring

Servo Relay Unit		Servo Drive	
Wire/mark color	No.		No.
Blue/Red (1)	1		7
Blue/Black (1)	2		38
Pink/Red (1)	3		5
Pink/Black (1)	4		6
Green/Red (1)	5		3
Green/Black (1)	6		4
Orange/Red (1)	7		
-	8		30
Orange/Black (1)	9		10
Gray/Red (1)	10		23
Gray/Black (1)	11		24
Blue/Red (2)	12		39
Blue/Black (2)	13		29
-	14		
Pink/Red (2)	15		27
Pink/Black (2)	16		31
Green/Red (2)	17		11
Green/Black (2)	18		37
Orange/Red (2)	19		36
Not specified	20		Shell

#### Servo Relay Unit Connector

Connector socket: XG4M-2030

Strain relief: XG4T-2004

#### Cable

AWG28 × 10P UL2464

#### Servo Drive Connector

Connector plug: 10150-3000PE (Sumitomo 3M)

Connector case: 10350-52A0-008 (Sumitomo 3M)

### 3-5 Servo Relay Units and Cable Specifications

#### ■ Servo Drive Cable (XW2Z-□J-B26)

This Cable connects the Servo Drive to a Servo Relay Unit (XW2B-80J7-12A). Use this Cable only with the FQM1-MMP22 Motion Control Module.

#### Cable Models

Model	Length (L)	Outer diameter of sheath	Weight
XW2Z-100J-B26	1 m	9.1 dia.	Approx. 0.1 kg
XW2Z-200J-B26	2 m		Approx. 0.2 kg

**Note** Do not use a Servo Relay Unit Cable for line receiver inputs (+CWLD: CN1 pin 44, -CWLD: CN1 pin 45, +CCWLD: CN1 pin 46, -CCWLD: CN1 pin 47).

Use a General-purpose Control Cable (R88A-CPG□S) and prepare wiring suited for the controller to be connected.

#### Connection Configuration and Dimensions

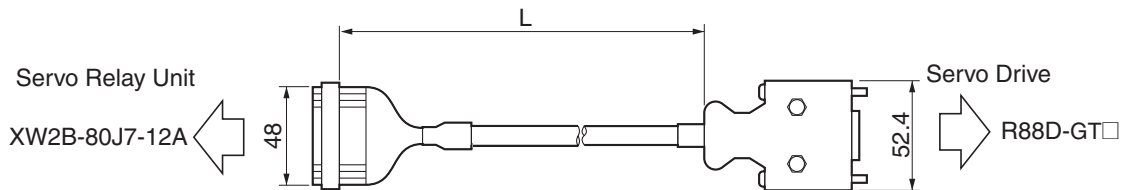

#### Wiring

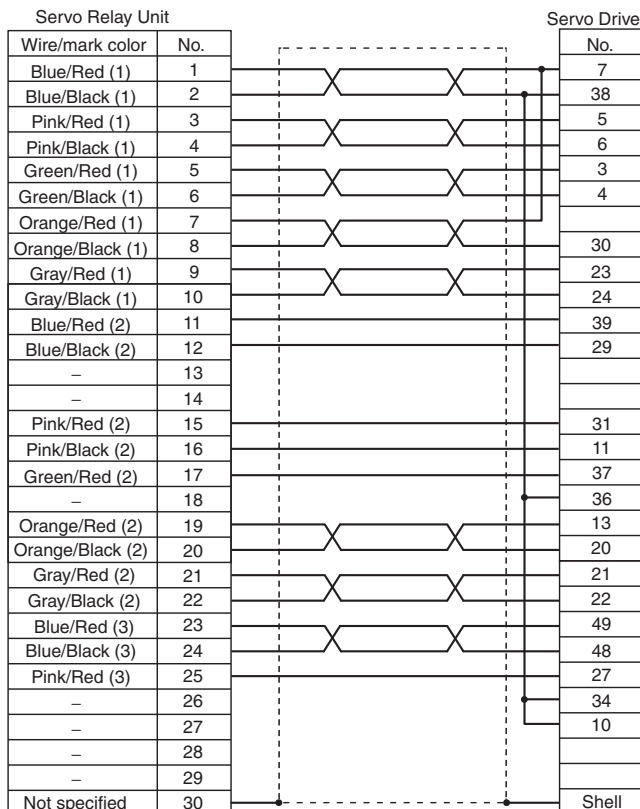

#### Servo Relay Unit Connector

Connector socket: XG4M-3030

Strain relief: XG4T-3004

#### Cable

AWG28 × 13P UL2464

#### Servo Drive Connector

Connector plug: 10150-3000PE (Sumitomo 3M)

Connector case: 10350-52A0-008 (Sumitomo 3M)



#### ■ Servo Drive Cable (XW2Z-□J-B27)

This Cable connects the Servo Drive to a Servo Relay Unit (XW2B-80J7-12A). Use this Cable only with the FQM1-MMA22 Motion Control Module.

#### Cable Models

Model	Length (L)	Outer diameter of sheath	Weight
XW2Z-100J-B27	1 m	9.1 dia.	Approx. 0.1 kg
XW2Z-200J-B27	2 m		Approx. 0.2 kg

#### Connection Configuration and Dimensions

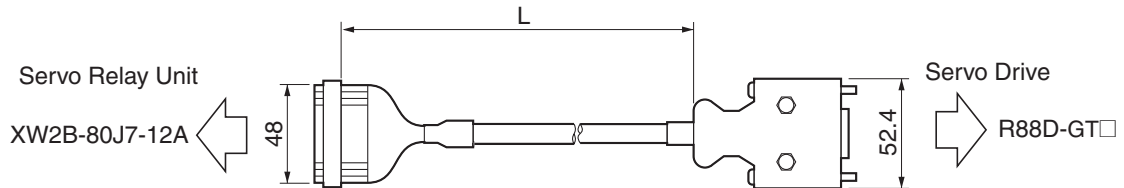

#### Wiring

Servo Relay Unit		Servo Drive	
Wire/mark color	No.		No.
Blue/Red (1)	1		7
Blue/Black (1)	2		38
Pink/Red (1)	3		14
Pink/Black (1)	4		15
-	5		
-	6		
-	7		
-	8		
Green/Red (1)	9		23
Green/Black (1)	10		24
Orange/Red (1)	11		35
Orange/Black (1)	12		29
Gray/Red (1)	13		16
Gray/Black (1)	14		17
Blue/Red (2)	15		31
Blue/Black (2)	16		11
Pink/Red (2)	17		37
-	18		36
Green/Red (2)	19		13
Green/Black (2)	20		20
Orange/Red (2)	21		21
Orange/Black (2)	22		22
Gray/Red (2)	23		49
Gray/Black (2)	24		48
Blue/Red (3)	25		27
-	26		34
-	27		10
-	28		
-	29		
Not specified	30		Shell

#### Servo Relay Unit Connector

Connector socket: XG4M-3030

Strain relief: XG4T-3004

#### Cable

AWG28 × 13P UL2464

#### Servo Drive Connector

Connector plug: 10150-3000PE (Sumitomo 3M)

Connector case: 10350-52A0-008 (Sumitomo 3M)

### 3-5 Servo Relay Units and Cable Specifications

#### ■ Servo Drive Cable (XW2Z-□J-B31)

This Cable connects the Servo Drive to a Servo Relay Unit (XW2B-20J6-8A, XW2B-40J6-9A).

#### Cable Models

Model	Length (L)	Outer diameter of sheath	Weight
XW2Z-100J-B31	1 m	8.1 dia.	Approx. 0.1 kg
XW2Z-200J-B31	2 m		Approx. 0.2 kg

**Note** Do not use a Servo Relay Unit Cable for line receiver inputs (+CWLD: CN1 pin 44, -CWLD: CN1 pin 45, +CCWLD: CN1 pin 46, -CCWLD: CN1 pin 47).  
Use a General-purpose Control Cable (R88A-CPG□S) and prepare wiring suited for the controller to be connected.

#### Connection Configuration and Dimensions

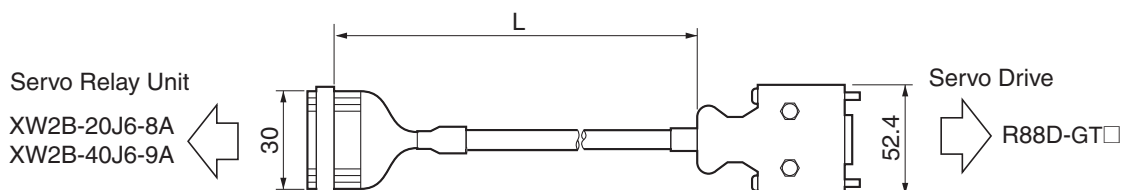

#### Wiring

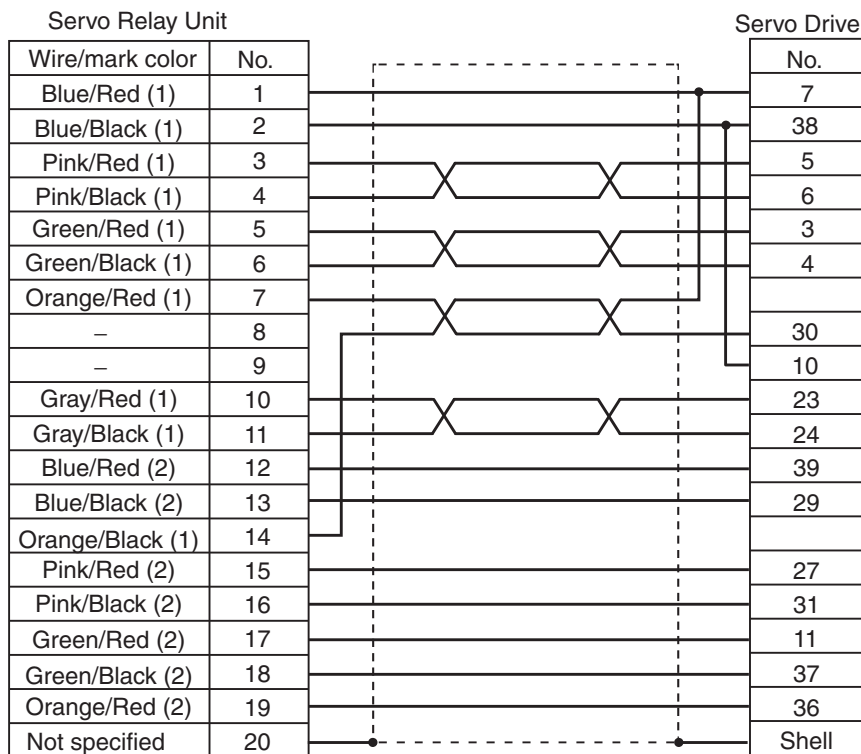

#### Servo Relay Unit Connector

Connector socket: XG4M-2030

Strain relief: XG4T-2004

#### Cable

AWG28 × 10P UL2464

#### Servo Drive Connector

Connector plug: 10150-3000PE (Sumitomo 3M)

Connector case: 10350-52A0-008 (Sumitomo 3M)

## Position Control Unit-Servo Relay Unit Cable Specifications

### ■ Position Control Unit Cable (XW2Z-□J-A3)

This Cable connects a Programmable Controller (CQM1-CPU43-V1) to a Servo Relay Unit (XW2B-20J6-3B).

#### Cable Models

Model	Length (L)	Outer diameter of sheath	Weight
XW2Z-050J-A3	50 cm	7.5 dia.	Approx. 0.1 kg
XW2Z-100J-A3	1 m		Approx. 0.1 kg

#### Connection Configuration and Dimensions

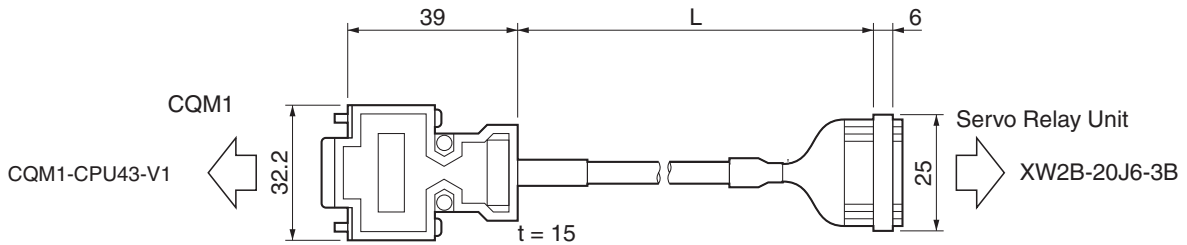

#### Wiring

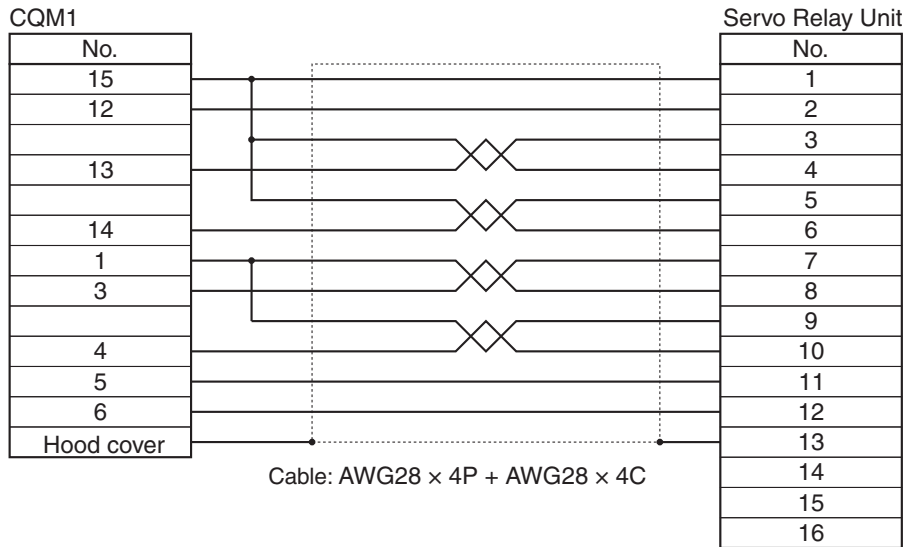

### 3-5 Servo Relay Units and Cable Specifications

#### ■ Position Control Unit Cable (XW2Z-□J-A6)

This Cable connects a Position Control Unit (CS1W-NC113) to a Servo Relay Unit (XW2B-20J6-1B).

#### Cable Models

Model	Length (L)	Outer diameter of sheath	Weight
XW2Z-050J-A6	50 cm	8.0 dia.	Approx. 0.1 kg
XW2Z-100J-A6	1 m		Approx. 0.1 kg

#### Connection Configuration and Dimensions

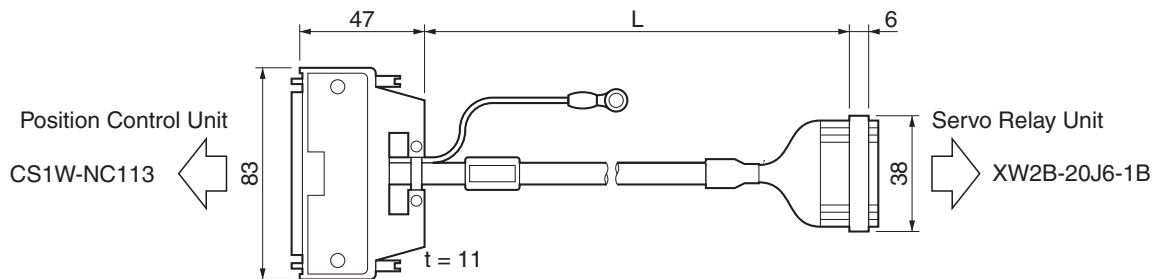

#### Wiring

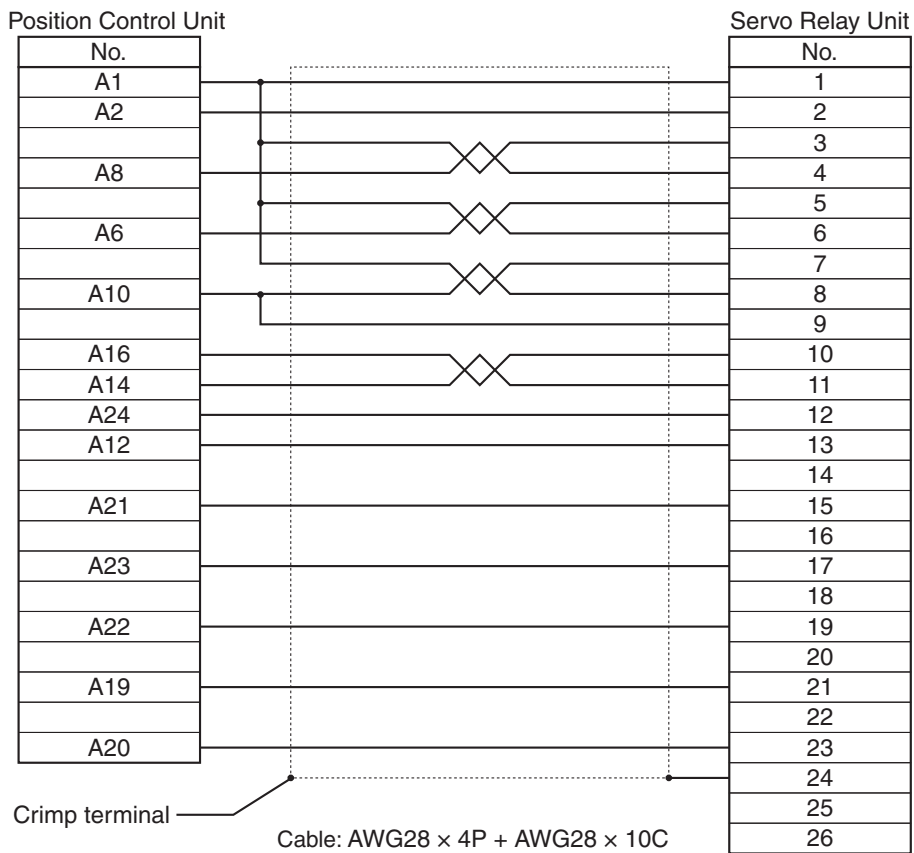

#### ■ Position Control Unit Cable (XW2Z-□J-A7)

This Cable connects a Position Control Unit (C1W-NC213 or CS1W-NC413) to a Servo Relay Unit (XW2B-40J6-2B).

#### Cable Models

Model	Length (L)	Outer diameter of sheath	Weight
XW2Z-050J-A7	50 cm	10.0 dia.	Approx. 0.1 kg
XW2Z-100J-A7	1 m		Approx. 0.2 kg

#### Connection Configuration and Dimensions

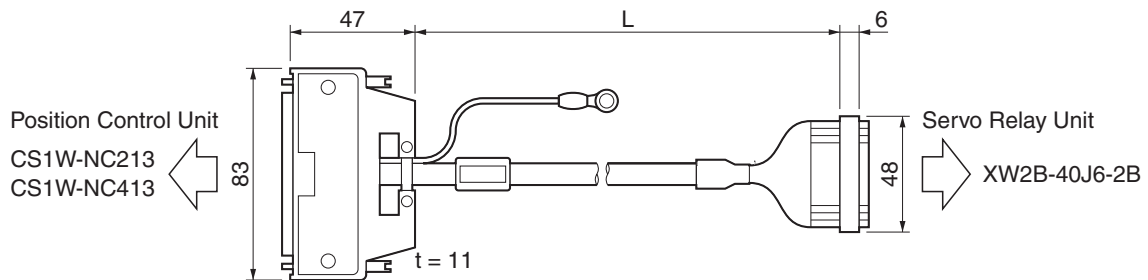

#### Wiring

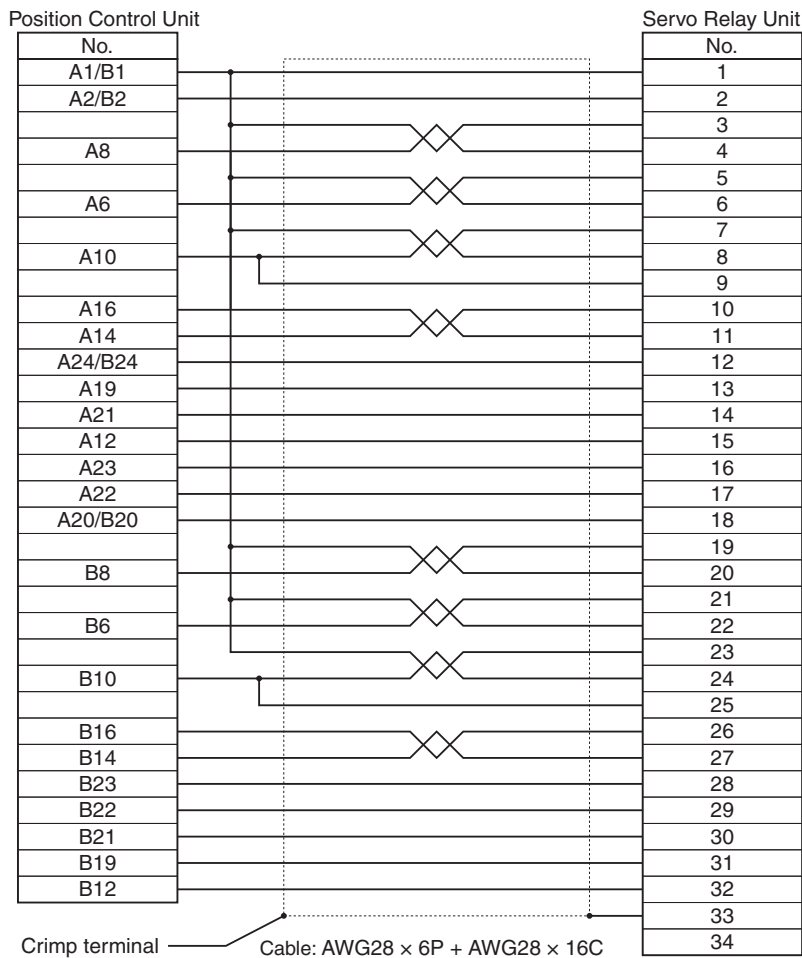

### 3-5 Servo Relay Units and Cable Specifications

#### ■ Position Control Unit Cable (XW2Z-□J-A10)

This Cable connects a Position Control Unit (CS1W-NC133) to a Servo Relay Unit (XW2B-20J6-1B).

#### Cable Models

Model	Length (L)	Outer diameter of sheath	Weight
XW2Z-050J-A10	50 cm	10.0 dia.	Approx. 0.1 kg
XW2Z-100J-A10	1 m		Approx. 0.2 kg

#### Connection Configuration and Dimensions

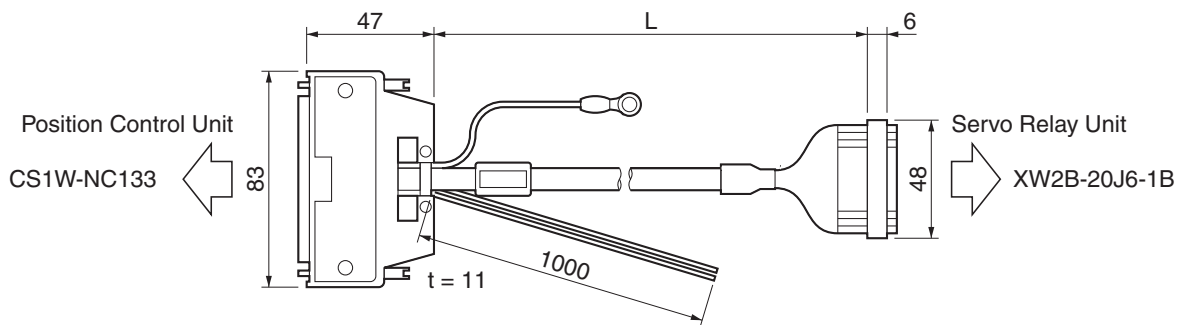

#### Wiring

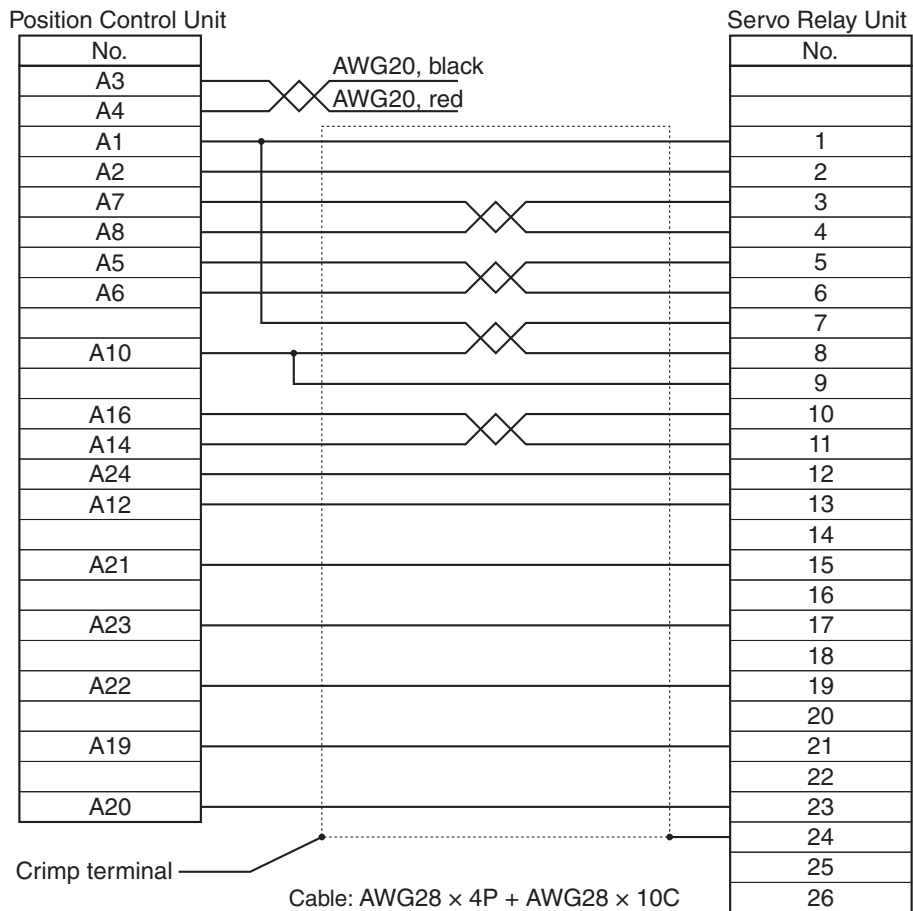

#### ■ Position Control Unit Cable (XW2Z-□J-A11)

This Cable connects a Position Control Unit (CS1W-NC233/433) to a Servo Relay Unit (XW2B-40J6-2B).

#### Cable Models

Model	Length (L)	Outer diameter of sheath	Weight
XW2Z-050J-A11	50 cm	10.0 dia.	Approx. 0.1 kg
XW2Z-100J-A11	1 m		Approx. 0.2 kg

#### Connection Configuration and Dimensions

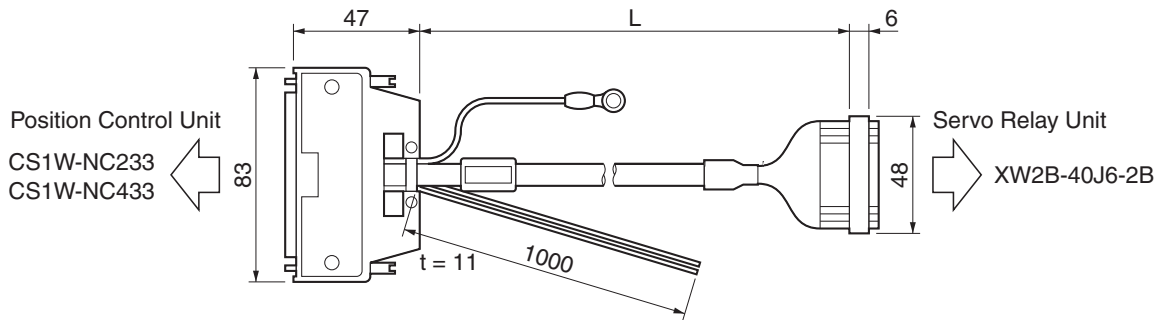

#### Wiring

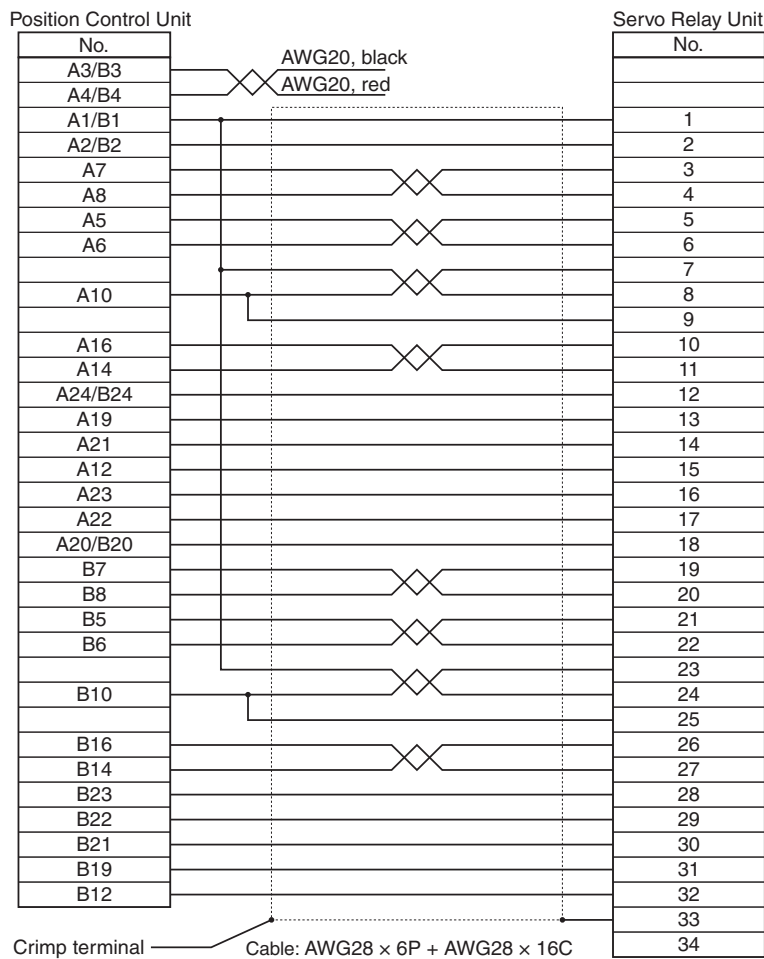

### 3-5 Servo Relay Units and Cable Specifications

#### ■ Position Control Unit Cable (XW2Z-□J-A14)

This Cable connects a Position Control Unit (CJ1W-NC113) to a Servo Relay Unit (XW2B-20J6-1B).

#### Cable Models

Model	Length (L)	Outer diameter of sheath	Weight
XW2Z-050J-A14	50 cm	10.0 dia.	Approx. 0.1 kg
XW2Z-100J-A14	1 m		Approx. 0.2 kg

#### Connection Configuration and Dimensions

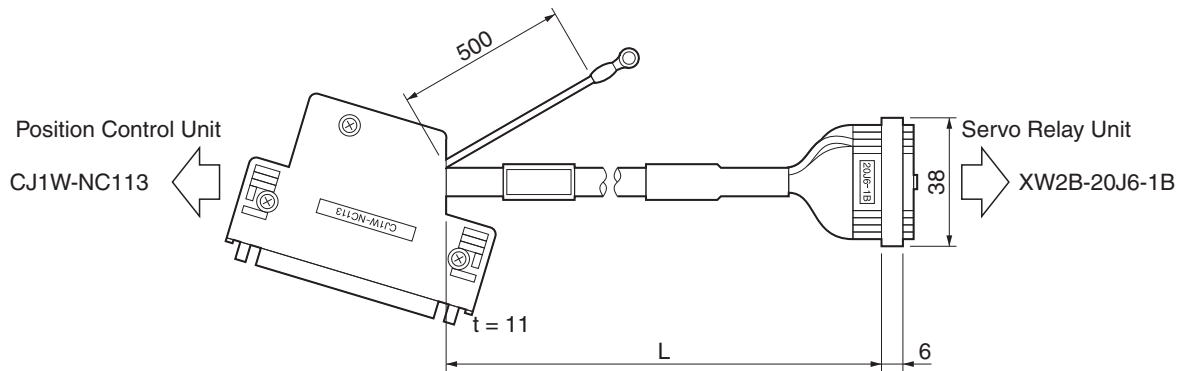

#### Wiring

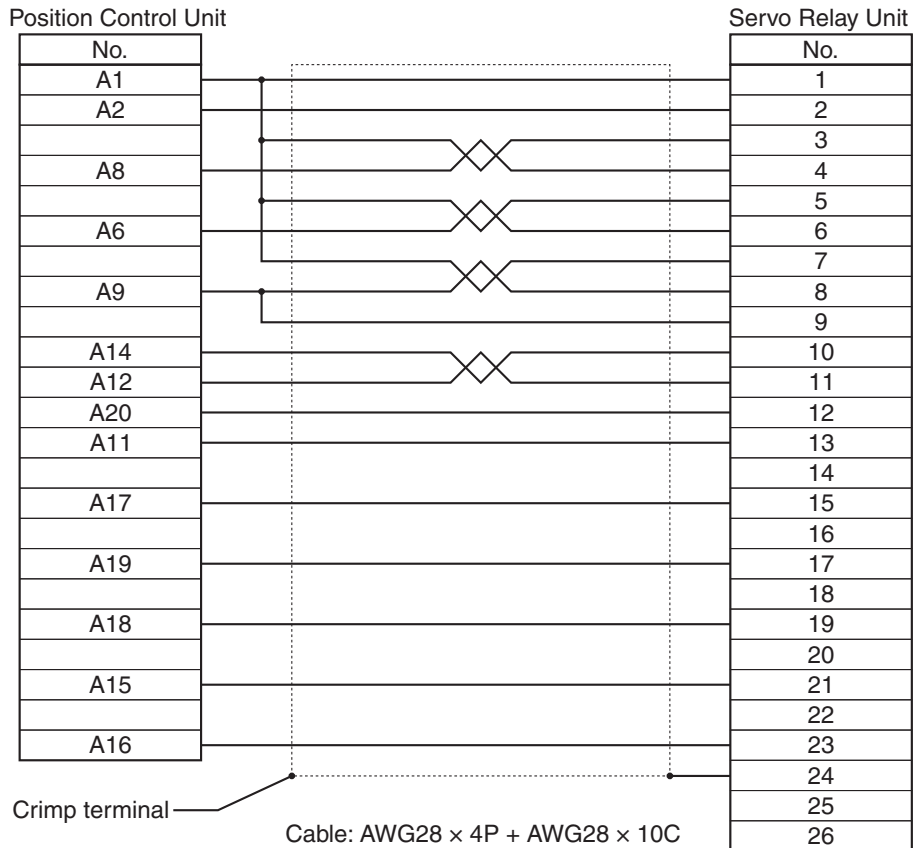



#### ■ Position Control Unit Cable (XW2Z-□J-A15)

This Cable connects a Position Control Unit (CJ1W-NC213/NC413) to a Servo Relay Unit (XW2B-40J6-2B).

#### Cable Models

Model	Length (L)	Outer diameter of sheath	Weight
XW2Z-050J-A15	50 cm	10.0 dia.	Approx. 0.1 kg
XW2Z-100J-A15	1 m		Approx. 0.2 kg

#### Connection Configuration and Dimensions

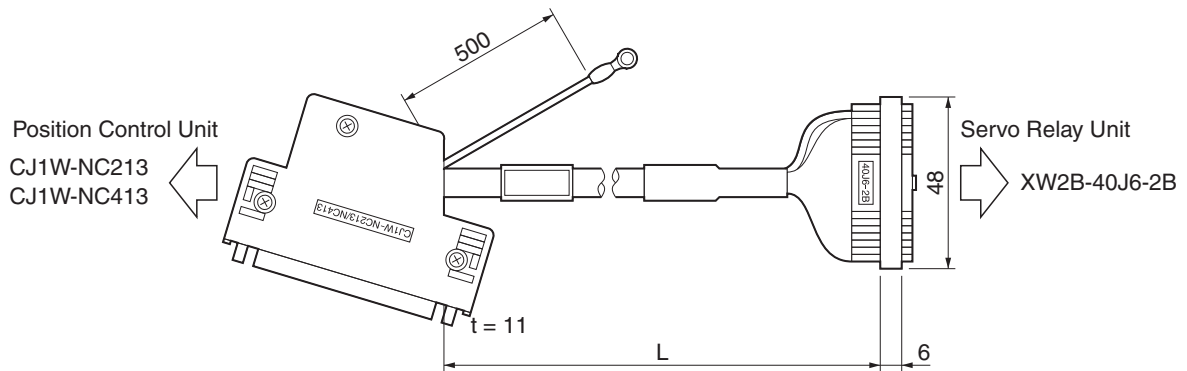

#### Wiring

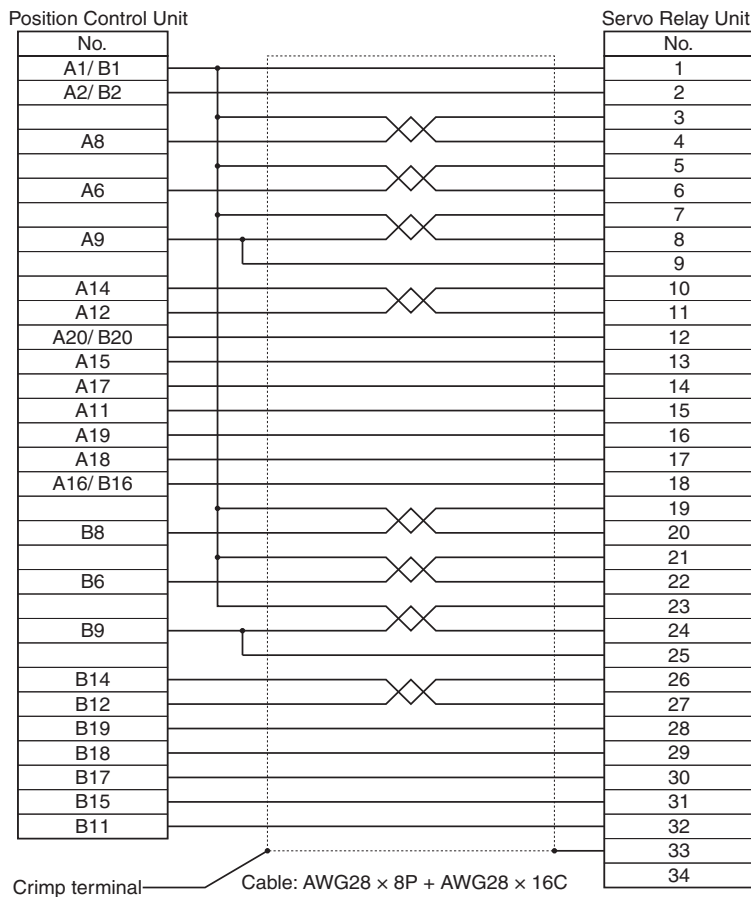

### 3-5 Servo Relay Units and Cable Specifications

#### ■ Position Control Unit Cable (XW2Z-□J-A18)

This Cable connects a Position Control Unit (CJ1W-NC133) to a Servo Relay Unit (XW2B-20J6-1B).

#### Cable Models

Model	Length (L)	Outer diameter of sheath	Weight
XW2Z-050J-A18	50 cm	10.0 dia.	Approx. 0.1 kg
XW2Z-100J-A18	1 m		Approx. 0.2 kg

#### Connection Configuration and Dimensions

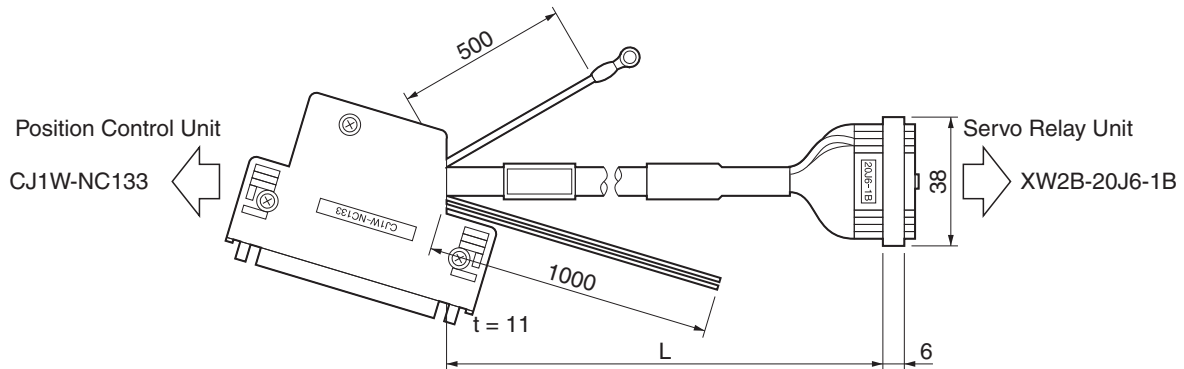

#### Wiring

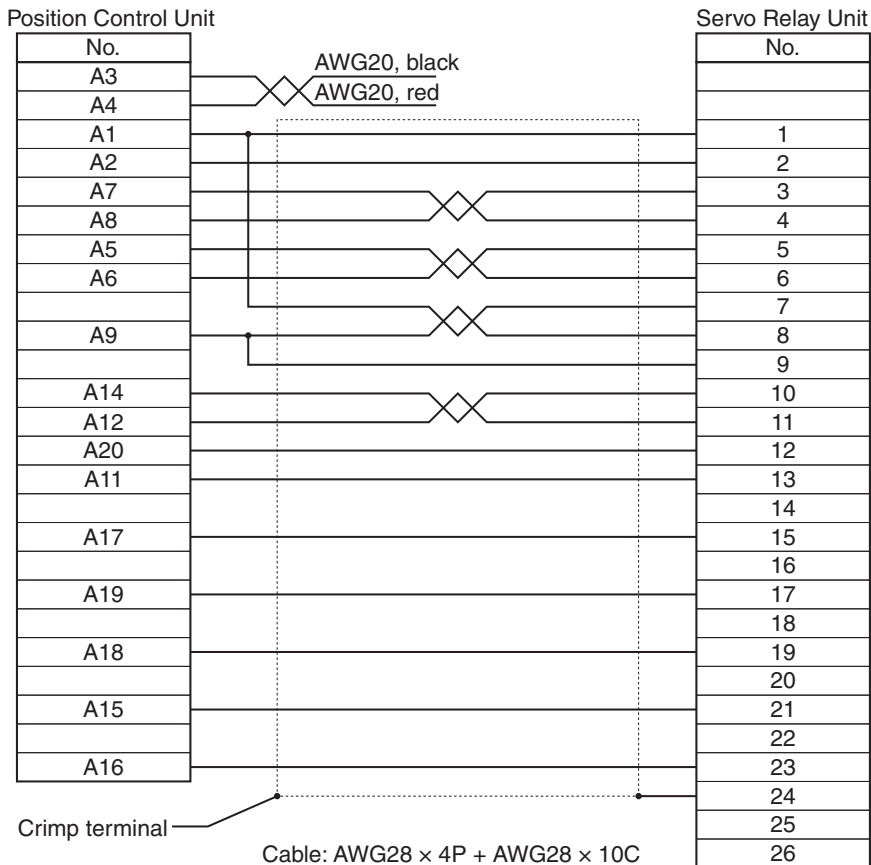

■ Position Control Unit Cable (XW2Z-□J-A19)

This Cable connects a Position Control Unit (CJ1W-NC233/NC433) to a Servo Relay Unit (XW2B-40J6-2B).

Cable Models

Model	Length (L)	Outer diameter of sheath	Weight
XW2Z-050J-A19	50 cm	10.0 dia.	Approx. 0.1 kg
XW2Z-100J-A19	1 m		Approx. 0.2 kg

Connection Configuration and Dimensions

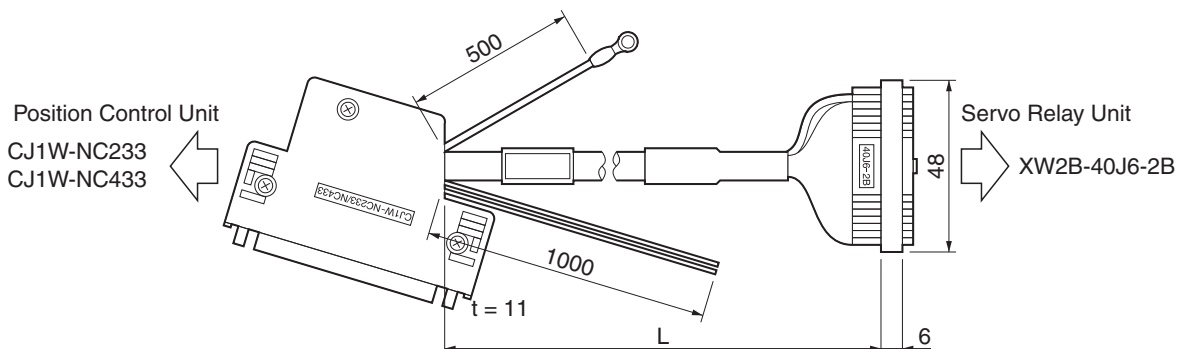

Wiring

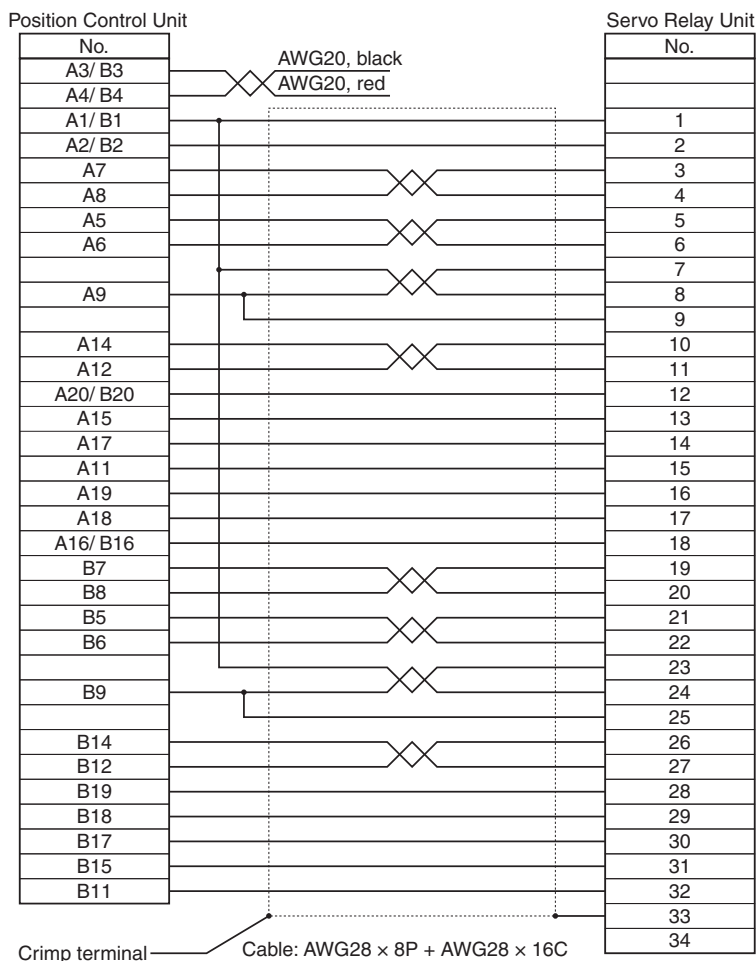

### 3-5 Servo Relay Units and Cable Specifications

#### ■ Position Control Unit Cable (XW2Z-□J-A33)

This Cable connects a Programmable Controller (CJ1M-CPU21/CPU22/CPU23) to a Servo Relay Unit (XW2B-20J6-8A or XW2B-40J6-9A).

#### Cable Models

Model	Length (L)	Outer diameter of sheath	Weight
XW2Z-050J-A33	50 cm	10.0 dia.	Approx. 0.1 kg
XW2Z-100J-A33	1 m		Approx. 0.2 kg

#### Connection Configuration and Dimensions

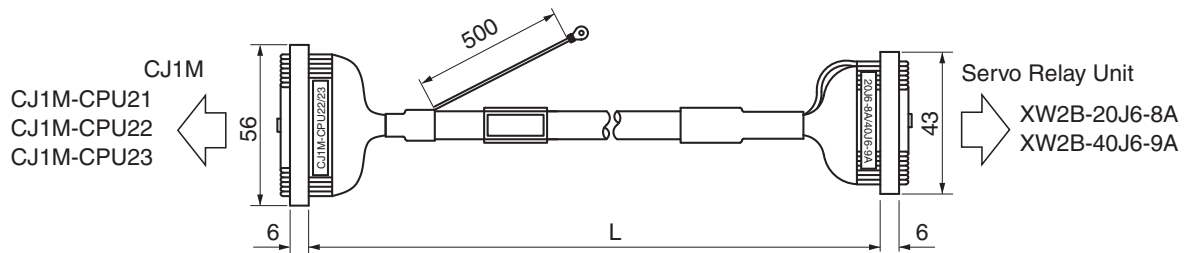

#### Wiring

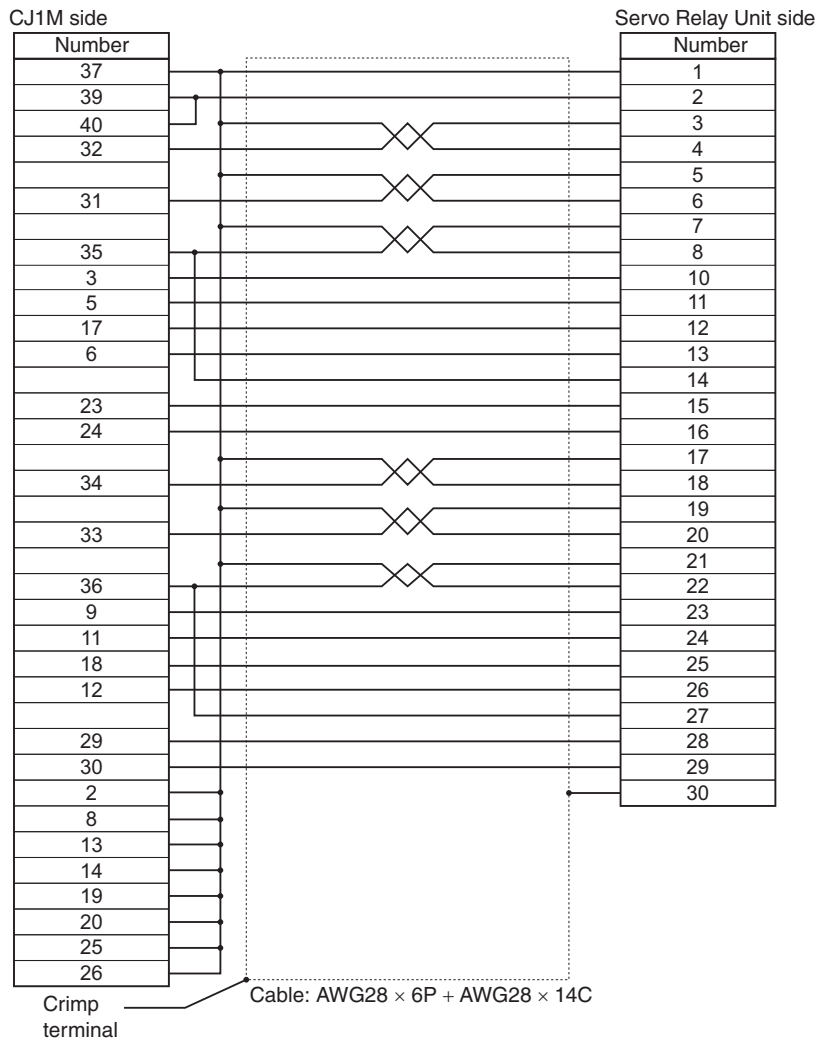

#### ■ Position Control Unit Cable (XW2Z-□J-A28)

This Cable connects the general-purpose I/O connector of a Flexible Motion Control Module (FQM1-MMP22/-MMA22) to a Servo Relay Unit (XW2B-80J7-12A).

#### Cable Models

Model	Length (L)	Outer diameter of sheath	Weight
XW2Z-050J-A28	50 cm	10.0 dia.	Approx. 0.1 kg
XW2Z-100J-A28	1 m		Approx. 0.2 kg
XW2Z-200J-A28	2 m		Approx. 0.3 kg

#### Connection Configuration and Dimensions

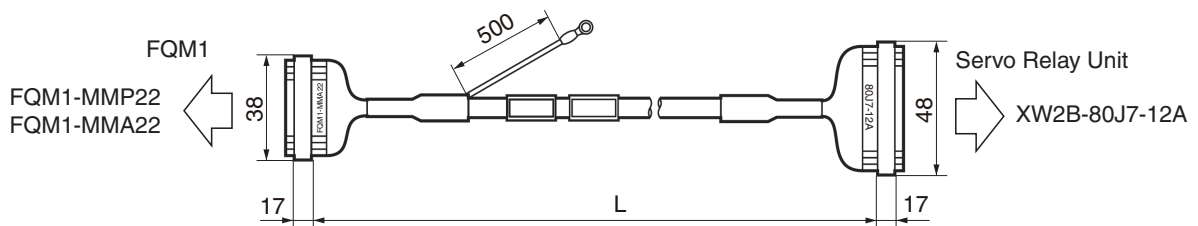

#### Wiring

FQM1		Servo Relay Unit	
No.		No.	
1		1	
2		2	
3		3	
4		4	
5		5	
6		6	
7		7	
8		8	
9		9	
10		10	
11		11	
12		12	
13		13	
14		14	
15		15	
16		16	
17		17	
18		18	
19		19	
20		20	
21		21	
22		22	
23		23	
24		24	
25			
26		33	
		34	

Crimp terminal — Cable: AWG28 × 24C

### 3-5 Servo Relay Units and Cable Specifications

#### ■ Position Control Unit Cable (XW2Z-□J-A30)

This Cable connects the special I/O connector of a Flexible Motion Control Module (FQM1-MMP22) to a Servo Relay Unit (XW2B-80J7-12A).

#### Cable Models

Model	Length (L)	Outer diameter of sheath	Weight
XW2Z-050J-A30	50 cm	10.0 dia.	Approx. 0.1 kg
XW2Z-100J-A30	1 m		Approx. 0.2 kg
XW2Z-200J-A30	2 m		Approx. 0.3 kg

#### Connection Configuration and Dimensions

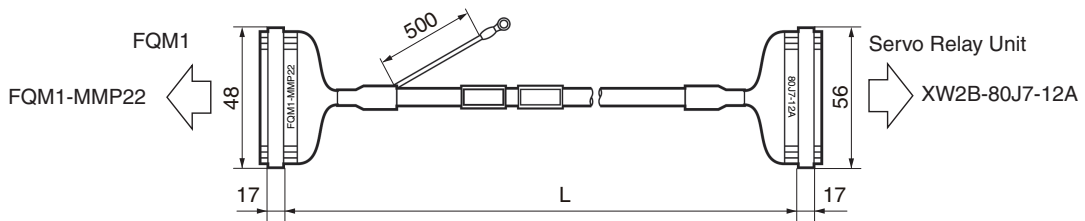

#### Wiring

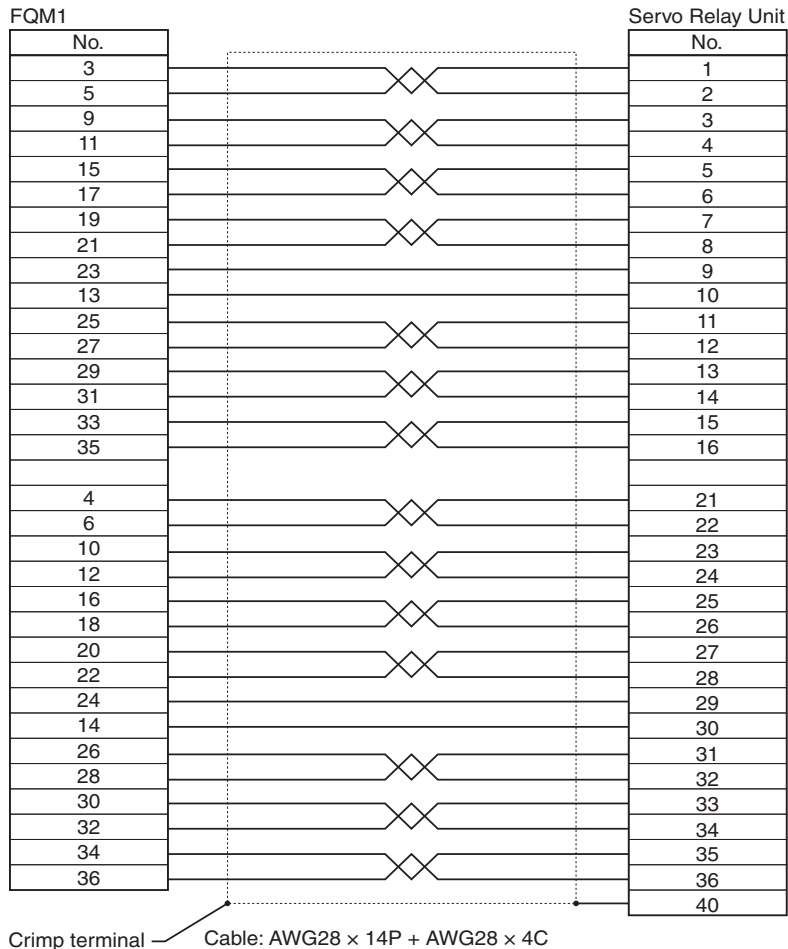

#### ■ Position Control Unit Cable (XW2Z-□J-A31)

This Cable connects the special I/O connector of a Flexible Motion Control Module (FQM1-MMA22) to a Servo Relay Unit (XW2B-80J7-12A).

#### Cable Models

Model	Length (L)	Outer diameter of sheath	Weight
XW2Z-050J-A31	50 cm	10.0 dia.	Approx. 0.1 kg
XW2Z-100J-A31	1 m		Approx. 0.2 kg
XW2Z-200J-A31	2 m		Approx. 0.3 kg

#### Connection Configuration and Dimensions

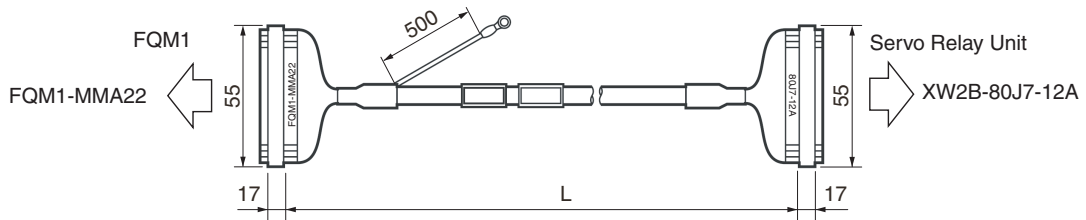

#### Wiring

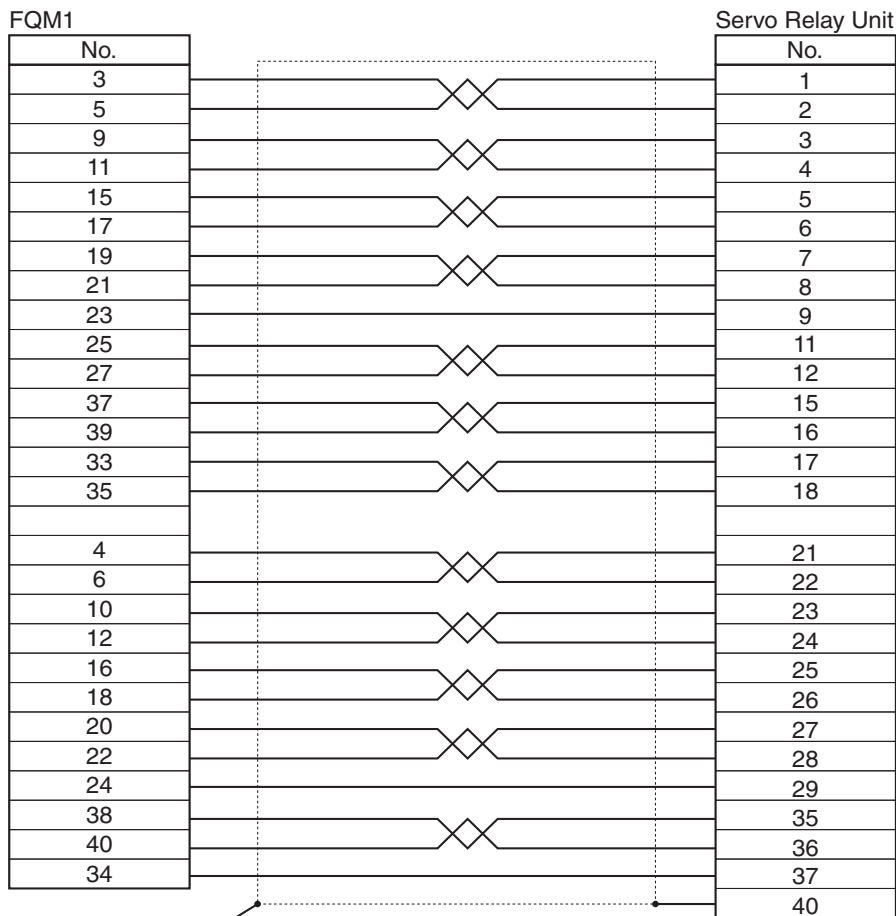

Crimp terminal Cable: AWG28 x 18P

## 3-6 Parameter Unit Specifications

### ■ R88A-PR02G Hand-held Parameter Unit

The Parameter Unit is required to operate the Servo Drive from a distance away from the Servo Drive, or to operate and monitor the Servo Drive from a control panel. The cable connected to the Parameter Unit is 1.5 m long.

### ■ General Specifications

Item	Specifications
Ambient operating temperature and humidity	0 to 55°C, 90% RH max. (with no condensation)
Ambient storage temperature and humidity	-20 to 80°C, 90% RH max. (with no condensation)
Operating and storage atmosphere	No corrosive gases
Vibration resistance	5.9 m/s <sup>2</sup> max.

### ■ Performance Specifications

Item	Specifications	
Type	Hand-held	
Cable length	1.5 m	
Connectors	Mini DIN 8-pin MD connector	
Display	7-segment LED	
Dimensions	62 (W) × 114 (H) × 15 (D) mm	
Weight	Approx. 0.1 kg (including cable)	
Communications specifications	Standard	RS-232
	Communications method	Asynchronous (ASYNC)
	Baud rate	9,600 bps
	Start bits	1 bit
	Data	8 bits
	Parity	None
	Stop bits	1 bit



## 3-7 External Regeneration Resistor Specifications

### External Regeneration Resistor Specifications

#### ■ R88A-RR08050S

Model	Resistance	Nominal capacity	Regeneration absorption for 120°C temperature rise	Heat radiation condition	Thermal switch output specifications
R88A-RR08050S	50 Ω	80 W	20 W	Aluminum, 350 × 350, Thickness: 3.0	Operating temperature: 150°C ± 5°C NC contact Rated output (resistive load): 125 VAC, 0.1 A max. 30 VDC, 0.1 A max. (minimum current: 1 mA)

#### ■ R88A-RR080100S

Model	Resistance	Nominal capacity	Regeneration absorption for 120°C temperature rise	Heat radiation condition	Thermal switch output specifications
R88A-RR080100S	100 Ω	80 W	20 W	Aluminum, 350 × 350, Thickness: 3.0	Operating temperature: 150°C ± 5°C NC contact Rated output (resistive load): 125 VAC, 0.1 A max. 30 VDC, 0.1 A max. (minimum current: 1 mA)

#### ■ R88A-RR22047S1

Model	Resistance	Nominal capacity	Regeneration absorption for 120°C temperature rise	Heat radiation condition	Thermal switch output specifications
R88A-RR22047S1	47 Ω	220 W	70 W	Aluminum, 350 × 350, Thickness: 3.0	Operating temperature: 150°C ± 5°C NC contact Rated output (resistive load): 250 VAC, 0.2 A max. 42 VDC, 0.2 A max. (minimum current: 1 mA)

### 3-7 External Regeneration Resistor Specifications

#### ■ R88A-RR50020S

Model	Resistance	Nominal capacity	Regeneration absorption for 120°C temperature rise	Heat radiation condition	Thermal switch output specifications
R88A-RR50020S	20 Ω	500 W	180 W	Aluminum, 600 × 600, Thickness: 3.0	Operating temperature: 200°C ± 7°C NC contact Rated output (resistive load): 250 VAC, 0.2 A max. 42 VDC, 0.2 A max. (minimum current: 1 mA)

3

Specifications

## 3-8 Reactor Specifications

Connect a Reactor to the Servo Drive as a harmonic current control measure. Select a model matching the Servo Drive to be used.

### ■ Specifications

Servo Drive		Reactor							
Model	Number of power phases	Model	Rated current	Inductance	Weight				
R88D-GTA5L	Single-phase	3G3AX-DL2002	1.6 A	21.4 mH	Approx. 0.8 kg				
R88D-GT01L		3G3AX-DL2004	3.2 A	10.7 mH	Approx. 1.0 kg				
R88D-GT02L		3G3AX-DL2007	6.1 A	6.75 mH	Approx. 1.3 kg				
R88D-GT04L		3G3AX-DL2015	9.3 A	3.51 mH	Approx. 1.6 kg				
R88D-GT01H		3G3AX-DL2002	1.6 A	21.4 mH	Approx. 0.8 kg				
R88D-GT02H		3G3AX-DL2004	3.2 A	10.7 mH	Approx. 1.0 kg				
R88D-GT04H		3G3AX-DL2007	6.1 A	6.75 mH	Approx. 1.3 kg				
R88D-GT08H	Single-phase	3G3AX-DL2015	9.3 A	3.51 mH	Approx. 1.6 kg				
	3-phase	3G3AX-AL2025	10.0 A	2.8 mH	Approx. 2.8 kg				
R88D-GT10H	Single-phase	3G3AX-DL2015	9.3 A	3.51 mH	Approx. 1.6 kg				
	3-phase	3G3AX-AL2025	10.0 A	2.8 mH	Approx. 2.8 kg				
R88D-GT15H	Single-phase	3G3AX-DL2022	13.8 A	2.51 mH	Approx. 2.1 kg				
	3-phase	3G3AX-AL2025	10.0 A	2.8 mH	Approx. 2.8 kg				
R88D-GT20H	3-phase	3G3AX-AL2055	20.0 A	0.88 mH	Approx. 4.0 kg				
R88D-GT30H									
R88D-GT50H						3G3AX-AL2110	37.0 A	0.35 mH	Approx. 5.0 kg
R88D-GT75H						3G3AX-AL2220	70.0 A	0.18 mH	Approx. 10.0 kg



# Chapter 4

## System Design

4-1	Installation Conditions .....	4-1
	Servo Drives .....	4-1
	Servomotors.....	4-3
	Decelerators.....	4-7
4-2	Wiring .....	4-11
	Connecting Cables.....	4-11
	Selecting Connecting Cables.....	4-12
	Peripheral Device Connection Examples.....	4-17
	Main Circuit and Servomotor Connections .....	4-21
4-3	Wiring Conforming to EMC Directives.....	4-27
	Wiring Method.....	4-27
	Selecting Connection Components.....	4-32
4-4	Regenerative Energy Absorption .....	4-45
	Calculating the Regenerative Energy .....	4-45
	Servo Drive Regenerative Energy Absorption Capacity .....	4-48
	Absorbing Regenerative Energy with an External Regeneration Resistor .....	4-49
	Connecting an External Regeneration Resistor.....	4-49

# 4-1 Installation Conditions

## Servo Drives

### ■ Space around Drives

- Install Servo Drives according to the dimensions shown in the following illustration to ensure proper heat dispersion and convection inside the panel. If the Servo Drives are installed side by side, install a fan for air circulation to prevent uneven temperatures from developing inside the panel.

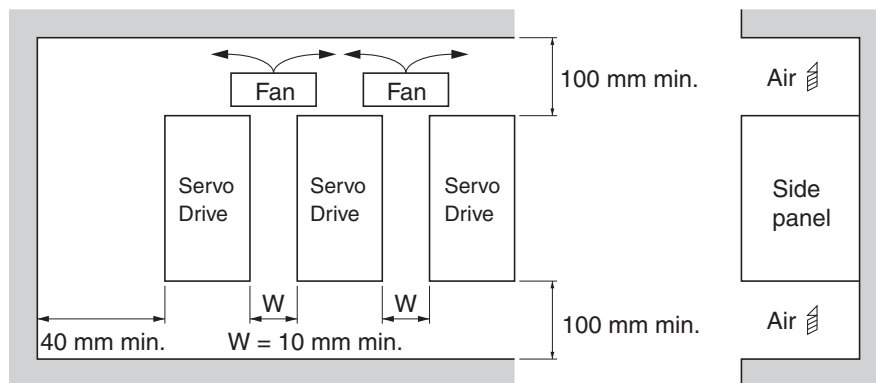

### ■ Mounting Direction

- Mount the Servo Drives in a direction (perpendicular) so that the model number can be seen properly.

### ■ Operating Environment

- The environment in which Servo Drives are operated must meet the following conditions. Servo Drives may malfunction if operated under any other conditions.
  - Ambient operating temperature: 0 to 55°C (Take into account temperature rises in the individual Servo Drives themselves.)
  - Ambient operating humidity: 90% RH max. (with no condensation)
  - Atmosphere: No corrosive gases.
  - Altitude: 1,000 m max.

### ■ Ambient Temperature Control

- Servo Drives should be operated in environments in which there is minimal temperature rise to maintain a high level of reliability.
- Temperature rise in any Unit installed in a closed space, such as a control box, will cause the Servo Drive's ambient temperature to rise. Use a fan or air conditioner to prevent the Servo Drive's ambient temperature from exceeding 55°C.
- Servo Drive surface temperatures may rise to as much as 30°C above the ambient temperature. Use heat-resistant materials for wiring, and keep its distance from any devices or wiring that are sensitive to heat.
- The service life of a Servo Drive is largely determined by the temperature around the internal electrolytic capacitors. The service life of an electrolytic capacitor is affected by a drop in electrostatic capacity and an increase in internal resistance, which can result in overvoltage alarms, malfunctioning due to noise, and damage to individual elements.

- If a Servo Drive is always operated at the ambient temperature of 55°C and with 100% of the rated torque and rated rotation speed, its service life is expected to be approximately 28,000 hours (excluding the axial-flow fan). A drop of 10°C in the ambient temperature will double the expected service life.

### ■ Keeping Foreign Objects Out of Units

- Place a cover over the Units or take other preventative measures to prevent foreign objects, such as drill filings, from getting into the Units during installation. Be sure to remove the cover after installation is complete. If the cover is left on during operation, Servo Drive's heat dissipation is blocked, which may result in malfunction.
- Take measures during installation and operation to prevent foreign objects such as metal particles, oil, machining oil, dust, or water from getting inside of Servo Drives.

## Servomotors

### ■ Operating Environment

- The environment in which the Servomotor is operated must meet the following conditions. Operating the Servomotor outside of the following ranges may result in malfunction of the Servomotor.

Ambient operating temperature: 0 to 40°C (See note.)

Ambient operating humidity: 85% RH max. (with no condensation)

Atmosphere: No corrosive gases.

**Note** The ambient temperature is the temperature at a point 5 cm from the Servomotor.

### ■ Impact and Load

- The Servomotor is resistant to impacts of up to  $98 \text{ m/s}^2$ . Do not apply heavy impacts or loads during transport, installation, or removal.
- When transporting, hold the Servomotor body itself, and do not hold the encoder, cable, or connector areas. Doing so may damage the Servomotor.
- Always use a pulley remover to remove pulleys, couplings, or other objects from the shaft.
- Secure cables so that there is no impact or load placed on the cable connector areas.

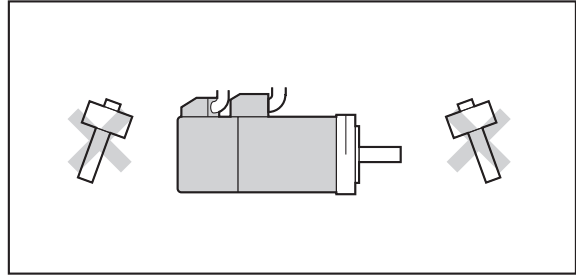

### ■ Connecting to Mechanical Systems

- The axial loads for Servomotors are specified in *Characteristics* on page 3-33. If an axial load greater than that specified is applied to a Servomotor, it will reduce the service life of the motor bearings and may break the motor shaft.
- When connecting to a load, use couplings that can sufficiently absorb mechanical eccentricity and declination.
- For spur gears, an extremely large radial load may be applied depending on the gear precision. Use spur gears with a high degree of precision (for example, JIS class 2: normal line pitch error of  $6 \mu\text{m}$  max. for a pitch circle diameter of 50 mm).
- If the gear precision is not adequate, allow backlash to ensure that no radial load is placed on the motor shaft.
- Bevel gears will cause a load to be applied in the thrust direction depending on the structural precision, the gear precision, and temperature changes. Provide appropriate backlash or take other measures to ensure that a thrust load larger than the specified level is not applied.
- Do not put rubber packing on the flange surface. If the flange is mounted with rubber packing, the motor flange may crack under the tightening force.

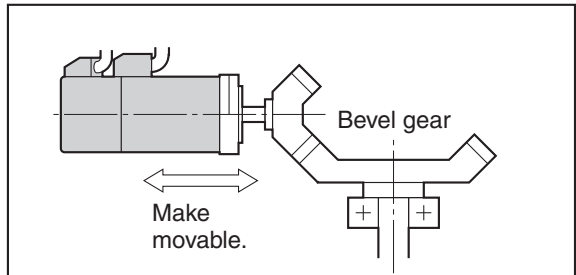
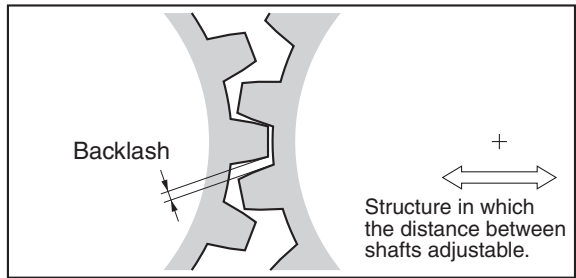
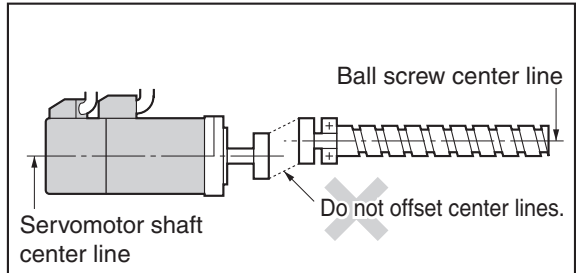



- When connecting to a V-belt or timing belt, consult the manufacturer for belt selection and tension.
- A radial load twice the belt tension will be placed on the motor shaft. Do not allow a radial load exceeding specifications to be placed on the motor shaft. If an excessive radial load is applied, the motor shaft and bearings may be damaged.
- Set up a movable pulley between the motor shaft and the load shaft so that the belt tension can be adjusted.

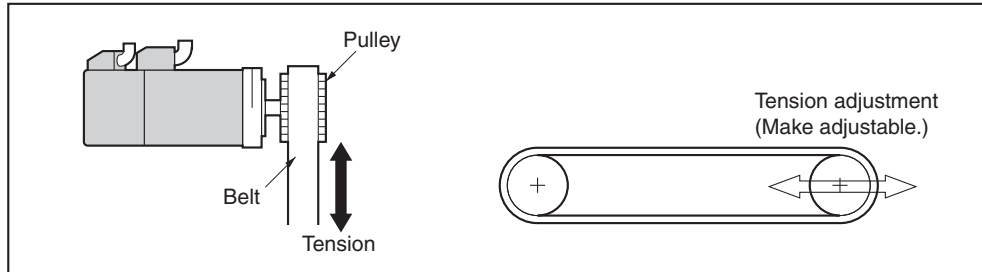

### ■ Water and Drip Resistance

- The protective structure for the Servomotors is as follows:  
IP65 (except for through-shaft parts and cable outlets)

### ■ Countermeasures against Oil

When using the Servo Motor in an environment in which the shaft through-hole is exposed to oil spray, use a Servomotor with an oil seal. The operating conditions for a Servomotor with an oil seal are as follows:

- Keep the oil level below the lip of the oil seal.
- Set up good lubricating conditions so that any oil spray falls on the oil seal.
- If the Servomotor is used with the shaft pointing upwards, be careful to not allow oil to accumulate at the lip of the oil seal.

### ■ Radiator Plate Installation Conditions

- When the Servomotor is installed in a small space, the Servomotor temperature may rise unless sufficient surface area is provided to allow heat dissipation from the Servomotor mounting surface. Take measures such as inserting a radiator plate between the Servomotor mounting surface and the flange. If radiator plates are not inserted, the motor may be damaged by increased temperatures. For radiator plate specifications, refer to *3-2 Servomotor Specifications*.
- Servomotor heating will depend on the material of the mounting surface and on the installation environment. Be sure to check the Servomotor temperature under actual operating conditions.
- The Servomotor temperature may rise sharply if the Servomotor is installed in an environment such as near a heat source. Take the following countermeasures as required by the installation environment.
  - ♦ Reduce the load ratio.
  - ♦ Modify the Servomotor's heat dissipation conditions.
  - ♦ Forcibly cool the Servomotor by installing a cooling fan.

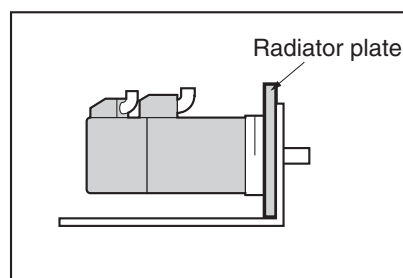

## 4-1 Installation Conditions

### ■ Oil Seal

The Servomotor oil seal dimensions are given below. The expected service life of an oil seal is approximately 5,000 hours. The actual life depends on the application conditions and environment. Oil seal installation and replacement are treated as repair work. For inquiries, consult your OMRON representative.

Motor model	Shaft diameter (mm)	Outer diameter (mm)	Width (mm)
R88M-G05030□	8.9	17	4
R88M-G10030□	8.9	17	4
R88M-G20030□	14	28	4
R88M-G40030□	14	28	4
R88M-G75030□	19.8	30	4
R88M-GP10030□	8.9	22	4
R88M-GP20030□	14	28	4
R88M-GP40030□	14	28	4
R88M-G1K030□	20	35	7
R88M-G1K530□	20	35	7
R88M-G2K030□	20	35	7
R88M-G3K030□	24	38	7
R88M-G4K030□	24	38	7
R88M-G5K030□	24	38	7
R88M-G1K020□	24	38	7
R88M-G1K520□	24	38	7
R88M-G2K020□	24	38	7
R88M-G3K020□	24	38	7
R88M-G4K020□	30	45	7
R88M-G5K020□	40	58	7
R88M-G7K515□	45	62	9
R88M-G90010□	24	38	7
R88M-G2K010□	40	58	7
R88M-G3K010□	40	58	7
R88M-G4K510□	45	62	9
R88M-G6K010□	45	62	9



When using the Servomotor in an environment where the Servomotor shaft will be exposed to oil, select a Servomotor with an oil seal.

#### Precautions

- ◆ Keep the oil level below the oil seal.
- ◆ If there is no oil at all on the oil seal, the oil seal, which is made of rubber, will be glazed. Use the Servomotor in an environment with a suitable amount of oil.
- ◆ Install the Servomotor so that oil does not accumulate around the oil seal.

### ■ Other Precautions

- Take measures to protect the shaft from corrosion.  
The shafts are coated with anti-corrosion oil when shipped, but anti-corrosion oil or grease should also be applied when connecting the shaft to a load.

 <b>WARNING</b>	
	Do not apply commercial power directly to the Servomotor. Doing so may result in fire.
	Do not dismantle or repair the product. Doing so may result in electric shock or injury.

## Decelerators

### ■ Installing Decelerators

#### Installing an R88G-HPG□□□ (Backlash = 3' Max.)

Use the following procedure to install the Decelerator on the Servomotor.

1. Turn the input joint and align the head of the bolt that secures the shaft with the rubber cap.
2. Apply sealant to the installation surface on the Servomotor (recommended sealant: Loctite 515).

**3. Gently insert the Servomotor into the Decelerator.**

As shown in the figures on the next page, stand the Decelerator upright and slide the Servomotor shaft into the input shaft joint while making sure it does not fall over. If the Decelerator cannot be stood upright, tighten each bolt evenly little by little to ensure that the Servomotor is not inserted at a tilt.

**4. Bolt together the Servomotor and the Decelerator flanges.**

Bolt Tightening Torque for Aluminum

Allen head bolt size	M4	M5	M6	M8	M10	M12
Tightening torque (N·m)	3.2	6.3	10.7	26.1	51.5	89.9

**5. Tighten the input joint bolt.**

Bolt Tightening Torque for Duralumin

Allen head bolt size	M3	M4	M6	M8
Tightening torque (N·m)	2.0	4.5	15.3	37.2

**Note** Always use the torque given in the table above. The Servomotor may slip or other problems may occur if the specified torque level is not satisfied.

The R88G-HPG11□ uses two set screws for the connecting section.

Allen head bolt size	M3
Tightening torque (N·m)	0.69

**6. Mount the supplied rubber cap to complete the installation procedure.**

(For the R88G-HPG11□, mount two screws with gaskets.)

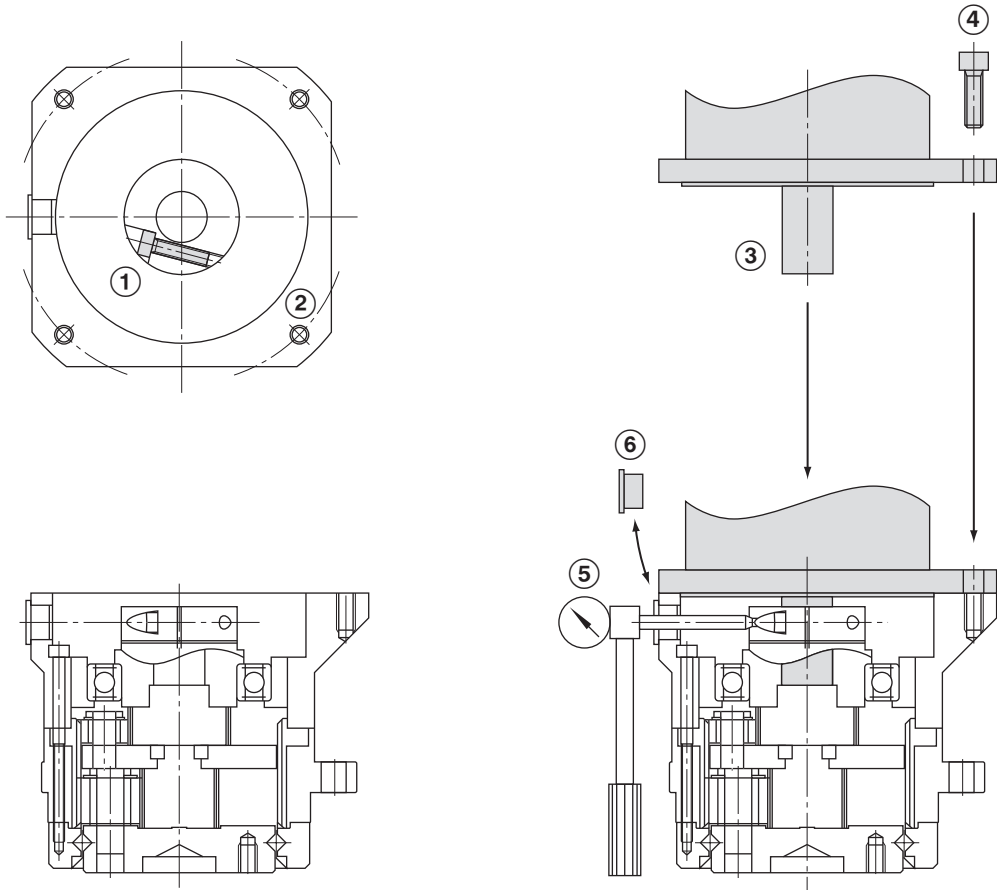

**Installing the Decelerator**

When installing the R88G-HPG□□□□, first make sure that the mounting surface is flat and that there are no burrs on the tap sections, and then bolt on the mounting flanges.

Mounting Flange Bolt Tightening Torque for Aluminum

R88G-HPG	11	14	20	32	50	65
Number of bolts	4	4	4	4	4	4
Bolt size	M3	M5	M8	M10	M12	M16
Mounting PCD (mm)	46	70	105	135	190	260
Tightening torque (N·m)	1.4	6.3	26.1	51.5	103	255

## 4-1 Installation Conditions

### Installing an R88G-VRSF□□□ (Backlash = 15' Max.)

Use the following procedure to install the Decelerator to the Servomotor.

**1. Turn the input joint and align the head of the bolt that secures the shaft with the rubber cap.**

Make sure the set bolts are loose.

**2. Gently insert the Servomotor into the Decelerator.**

As shown in the figures below, stand the Decelerator upright and slide the Servomotor shaft into the input shaft joint while making sure it does not fall over. If the Decelerator cannot be stood upright, tighten each bolt evenly little by little to ensure that the Servomotor is not inserted at a tilt.

**3. Bolt together the Servomotor and the Decelerator flanges.**

Bolt Tightening Torque

Allen head bolt size	M4	M5	M6
Tightening torque (N-m)	3.0	5.8	9.8

**4. Tighten the input joint bolt.**

Bolt Tightening Torque for Duralumin

Allen head bolt size	M3	M4	M5
Tightening torque (N-m)	1.5	3.5	7.1

**Note** Always use the torque given in the table above. Sliding or other problems may occur if the specified torque level is not satisfied.

**5. Mount the supplied rubber cap to complete the installation procedure.**

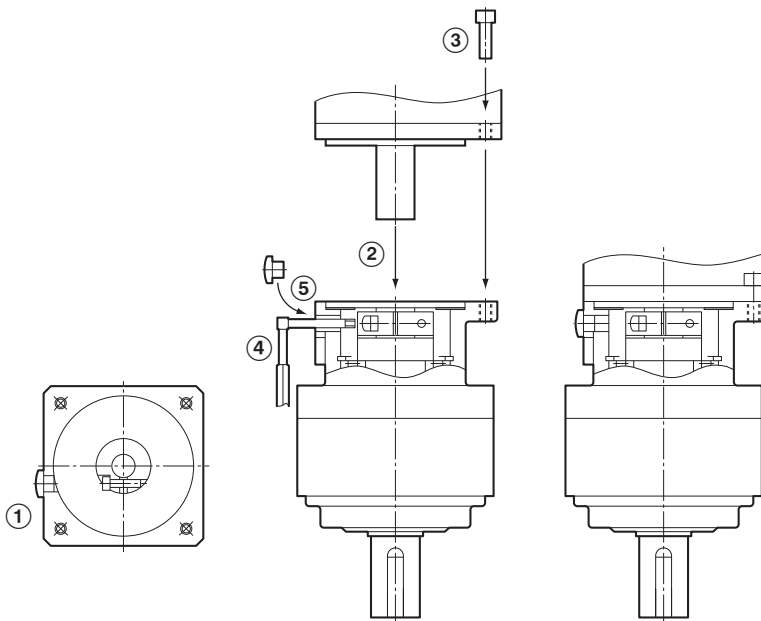

### Installing the Decelerator

When installing the R88G-VRSF□□□, first make sure that the mounting surface is flat and that there are no burrs on the tap sections, and then bolt on the mounting flanges.

Mounting Flange Bolt Tightening Torque for Aluminum

R88G-VRSF	B frame	C frame	D frame
Number of bolts	4	4	4
Bolt size	M5	M6	M8
Mounting PCD (mm)	60	90	115
Tightening torque (N·m)	5.8	9.8	19.6

### ■ Using Another Company's Decelerator (Reference Information)

If the system configuration requires another company's decelerator to be used in combination with an OMNUC G-Series Servomotor, select the decelerator so that the load on the motor shaft (i.e., both the radial and thrust loads) is within the allowable range.

(Refer to *Characteristics* on page 3-33 for details on the allowable loads for the motors.)

Also, select the decelerator so that the allowable input rotation speed and allowable input torque of the decelerator are not exceeded.

# 4-2 Wiring

## Connecting Cables

This section shows the types of connecting cables used in an OMNUC G-Series servo system. A wide selection of cables are available when configuring a servo system with an OMRON SYSMAC Motion Control Unit or Position Unit, which makes wiring easy.

4

### System Configuration

System Design

#### Controller

##### Motion Control Unit



CS1W-MC221/421(-V1)

#### 1 Motion Control Unit Cable

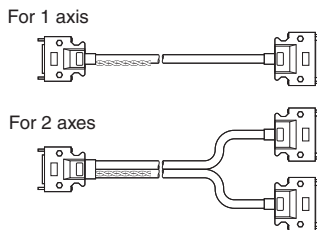

##### Position Control Unit

Position Control Unit with a pulse-string output  
 CJ1W-NC113/213/413  
 CJ1W-NC133/233/433  
 CS1W-NC113/213/413  
 CS1W-NC133/233/433  
 C200HW-NC113/213/413  
 CPU Units with Pulse-string Outputs  
 CQM1-CPU43-V1

#### 2 Servo Relay Unit Cable

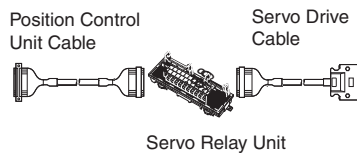

##### Other Controllers

CPU Units with Pulse-string Outputs  
 CP1H-X40D□-□  
 CP1H-XA40D□-□  
 CP1H-Y20DT-D  
 CP1L-□DT□-D  
 CJ1M-CPU21/22/23

Flexible Motion Controllers  
 FQ1M-MMA22  
 FQ1M-MMP22

#### 3 Connector Terminal Block and Cable

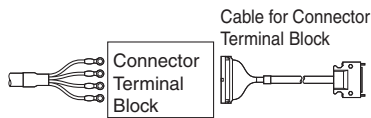

#### 4 General-purpose Control Cable and Control I/O Connector

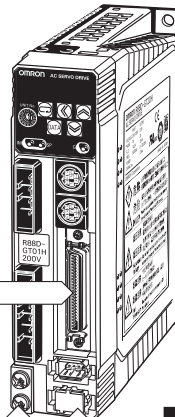
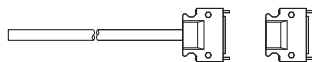

Servo Drive  
R88D-GT□

CN1 (Control I/O Connector)

Terminal block

CN2 (Encoder Connector)

5 Power Cable

6 Encoder Cable

7 Power Cable (Robot Cables) \*1

7 Encoder Cable (Robot Cables) \*1

\*1 Use a robot cable when the cable must be flexible.

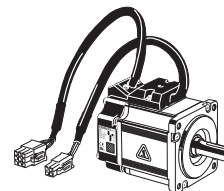

Servomotor  
R88M-G□



## Selecting Connecting Cables

### ■ Encoder Cables (Standard Cables)

Select an Encoder Cable matching the Servomotor to be used.

Servomotor type		Encoder Cable	Comments
3,000-r/min Servomotors	50 to 750 W <b>ABS</b>	R88A-CRGA□□□C	The □□□ digits in the model number indicate the cable length (3 m, 5 m, 10 m, 15 m, 20 m, 30 m, 40 m, or 50 m). Example model number for a 3-m cable: R88A-CRGA003C
	50 to 750 W <b>INC</b>	R88A-CRGB□□□C	
	1 to 5 kW	R88A-CRGC□□□N	
3,000-r/min Flat Servomotors	100 to 400 W <b>ABS</b>	R88A-CRGA□□□C	
	100 to 400 W <b>INC</b>	R88A-CRGB□□□C	
2,000-r/min Servomotors (1,500-r/min Servomotors)	1 to 7.5 kW	R88A-CRGC□□□N	
1,000-r/min Servomotors	900 W to 6 kW	R88A-CRGC□□□N	

**■ Power Cables (Standard Cables)**

Select a Power Cable matching the Servomotor to be used.

Servomotor type		Power Cables for Servomotors Without Brakes	Power Cables for Servomotors With Brakes
3,000-r/min Servomotors	50 to 750 W	R88A-CAGA□□□S	R88A-CAGA□□□S (For Power Connector) R88A-CAGA□□□B (For Brake Connector)
	1 to 1.5 kW	R88A-CAGB□□□S	R88A-CAGB□□□B
	2 kW	R88A-CAGC□□□S	R88A-CAGC□□□B
	3 to 5 kW	R88A-CAGD□□□S	R88A-CAGD□□□B
3,000-r/min Flat Servomotors	100 to 400 W	R88A-CAGA□□□S	R88A-CAGA□□□S (For Power Connector) R88A-CAGA□□□B (For Brake Connector)
2,000-r/min Servomotors (1,500-r/min Servomotors)	1 to 1.5 kW	R88A-CAGB□□□S	R88A-CAGB□□□B
	2 kW	R88A-CAGC□□□S	R88A-CAGC□□□B
	3 to 5kW	R88A-CAGD□□□S	R88A-CAGD□□□B
	7.5 kW	R88A-CAGE□□□S	R88A-CAGE□□□S (For Power Connector) R88A-CAGE□□□B (For Brake Connector)
1,000-r/min Servomotors	900 W	R88A-CAGB□□□S	R88A-CAGB□□□B
	2 to 4.5 kW	R88A-CAGD□□□S	R88A-CAGD□□□B
	6 kW	R88A-CAGE□□□S	R88A-CAGE□□□S (For Power Connector) R88A-CAGE□□□B (For Brake Connector)

**Note 1.** The □□□ digits in the model number indicate the cable length (3 m, 5 m, 10 m, 15 m, 20 m, 30 m, 40 m, or 50 m).

Example model number for a 3-m cable: R88A-CAGA003S

**Note 2.** For 50 to 750 W (3,000-r/min) Servomotors, Flat Servomotors, and 6-kW and higher Servomotors, there are separate connectors for power and brakes. Therefore, when a Servomotor with a brake is used, it will require both a Power Cable for a Servomotor without a brake and a Brake Cable.

**■ Encoder Cables (Robot Cables)**

Use a robot cable when the encoder cable must be flexible.

Servomotor type		Encoder Cable	Comments
3,000-r/min Servomotors	50 to 750 W <b>ABS</b>	R88A-CRGA□□□CR	The □□□ digits in the model number indicate the cable length. (3 m, 5 m, 10 m, 15 m, 20 m, 30 m, 40 m, or 50 m). Example model number for a 3-m cable: R88A-CRGA003CR
	50 to 750 W <b>INC</b>	R88A-CRGB□□□CR	
	1 to 5 kW	R88A-CRGC□□□NR	
3,000-r/min Flat Servomotors	100 to 400 W <b>ABS</b>	R88A-CRGA□□□CR	
	100 to 400 W <b>INC</b>	R88A-CRGB□□□CR	
2,000-r/min Servomotors	1 to 5 kW	R88A-CRGC□□□NR	
1,000-r/min Servomotors	900 W to 4.5 kW	R88A-CRGC□□□NR	

### ■ Power Cables (Robot Cables)

Use a robot cable when the power cable must be flexible.

Servomotor type		Power Cables for Servomotors without Brakes	Power Cables for Servomotors with Brakes
3,000-r/min Servomotors	50 to 750 W	R88A-CAGA□□□SR	R88A-CAGA□□□SR (For Power Connector) R88A-CAGA□□□BR (For Brake Connector)
	1 to 1.5 kW	R88A-CAGB□□□SR	R88A-CAGB□□□BR
	2 kW	R88A-CAGC□□□SR	R88A-CAGC□□□BR
	3 to 5 kW	R88A-CAGD□□□SR	R88A-CAGD□□□BR
3,000-r/min Flat Servomotors	100 to 400 W	R88A-CAGA□□□SR	R88A-CAGA□□□SR (For Power Connector) R88A-CAGA□□□BR (For Brake Connector)
2,000-r/min Servomotors	1 to 1.5 kW	R88A-CAGB□□□SR	R88A-CAGB□□□BR
	2 kW	R88A-CAGC□□□SR	R88A-CAGC□□□BR
	3 to 5 kW	R88A-CAGD□□□SR	R88A-CAGD□□□BR
1,000-r/min Servomotors	900 W	R88A-CAGB□□□SR	R88A-CAGB□□□BR
	2 to 4.5 kW	R88A-CAGD□□□SR	R88A-CAGD□□□BR

**Note 1.** The □□□ digits in the model number indicate the cable length (3 m, 5 m, 10 m, 15 m, 20 m, 30 m, 40 m, or 50 m). Example model number for a 3-m cable: R88A-CAGA003SR

**Note 2.** For 50 to 750 W (3,000-r/min) Servomotors and Flat Servomotors, there are separate connectors for power and brakes. Therefore, when a Servomotor with a brake is used, it will require both a Power Cable for a Servomotor without a brake and a Brake Cable.

### ■ Computer Monitor Cable

A Computer Monitor Cable and the Computer Monitor Software for Servo Drives (CX-Drive) are required to set Servo Drive parameters and perform monitoring with a personal computer.

Name/specifications		Model	Remarks
Computer Monitor Cable	2 m	R88A-CCG002P2	Only a 2-meter cable is available.

■ RS-485 Communications Cable

Multiple Servo Drives can be connected by connecting one Servo Drive to a computer or a host controller using RS-232 communications and by connecting the other Servo Drives together with RS-485 communications.

Name/specifications	Model	Remarks
RS-485 Communications Cable	R88A-CCG□□□P4	The □□□ digits in the model number indicate the cable length. RS-485 Communications Cables come in two lengths: 0.5 m and 1 m.

■ Servo Relay Units and Cables

Select the Servo Relay Unit and Cable according to the model of the Position Control Unit to be used.

Position Control Unit	Position Control Unit Cable	Servo Relay Unit	Servo Drive Cable
CQM1-CPU43-V1	XW2Z-□□□J-A3	XW2B-20J6-3B	XW2Z-□□□J-B25
CS1W-NC113	XW2Z-□□□J-A6	XW2B-20J6-1B	
C200HW-NC113			
CS1W-NC213	XW2Z-□□□J-A7	XW2B-40J6-2B	
CS1W-NC413			
C200HW-NC213			
C200HW-NC413			
CS1W-NC133	XW2Z-□□□J-A10	XW2B-20J6-1B	
CS1W-NC233	XW2Z-□□□J-A11	XW2B-40J6-2B	
CS1W-NC433			
CJ1W-NC113	XW2Z-□□□J-A14	XW2B-20J6-1B	
CJ1W-NC213	XW2Z-□□□J-A15	XW2B-40J6-2B	
CJ1W-NC413			
CJ1W-NC133	XW2Z-□□□J-A18	XW2B-20J6-1B	
CJ1W-NC233	XW2Z-□□□J-A19	XW2B-40J6-2B	
CJ1W-NC433			
CJ1M-CPU21	XW2Z-100J-A33	XW2B-20J6-8A XW2B-40J6-9A	XW2Z-□□□J-B31
CJ1M-CPU22			
CJ1M-CPU23			
FQM1-MMP22	XW2Z-□□□J-A28 XW2Z-□□□J-A30	XW2B-80J7-12A	XW2Z-□□□J-B26
FQM1-MMA22	XW2Z-□□□J-A28 XW2Z-□□□J-A31		XW2Z-□□□J-B27

**Note 1.** The cable length is indicated in the boxes of the model number (□□□). Position Control Unit cables come in two lengths: 0.5 m and 1 m (example for 0.5-m cable: XW2Z-050J-A3). Servo Drive Cables also come in two lengths: 1 m and 2 m (example for 1-m cable: XW2Z-100J-B25).

**Note 2.** Two Servo Drive Cables are required if 2-axis control is performed using one Position Control Unit.

### ■ Motion Control Unit Cable

There are special cables for 1-axis and 2-axis Motion Control Unit operation. Select the appropriate cable for the number of axes to be connected.

Motion Control Unit	Cable		Remarks
CS1W-MC221/421(-V1)	For 1 axis	R88A-CPG□□□M1	The □□□ digits in the model number indicate the cable length. Motion Control Unit Cables come in four lengths: 1 m, 2 m, 3 m, and 5 m. Example model number for 2-m 1-axis cable: R88A-CPG002M1
	For 2 axes	R88A-CPG□□□M2	

### ■ General-purpose Control Cable and Control I/O Connector

These cables and connector are used when connecting to Controllers for which no specific cable is available, and the cable for the Servo Drive's control I/O connector (CN1) is prepared by the user.

Name	Model	Remarks
General-purpose Control Cable	R88A-CPG□□□S	A cable for the control I/O connector (CN1) The □□□ digits in the model number indicate the cable length (either 1 m or 2 m). Example model number for 1-m cable: R88A-CPG001S
Control I/O Connector	R88A-CNU11C	This is the connector for connecting to the Control I/O Connector (CN1). (This item is a connector only.)

### ■ Connector-Terminal Blocks and Cables

These are for connecting to Controllers for which no specific cable is available, and are used to convert the Servo Drive's control I/O Connector (CN1) signals to a terminal block.

Connector Terminal Block	Cable	Remarks
XW2B-50G4 XW2B-50G5 XW2D-50G6	XW2Z-□□□J-B24	The □□□ digits in the model number indicate the cable length. There are two cable lengths: 1 m and 2 m. Example model number for 2-m cable: XW2Z-200J-B24

## Peripheral Device Connection Examples

### ■ R88D-GTA5L/-GT01L/-GT02L/-GT04L R88D-GT01H/-GT02H/-GT04H/-GT08H/-GT10H/-GT15H

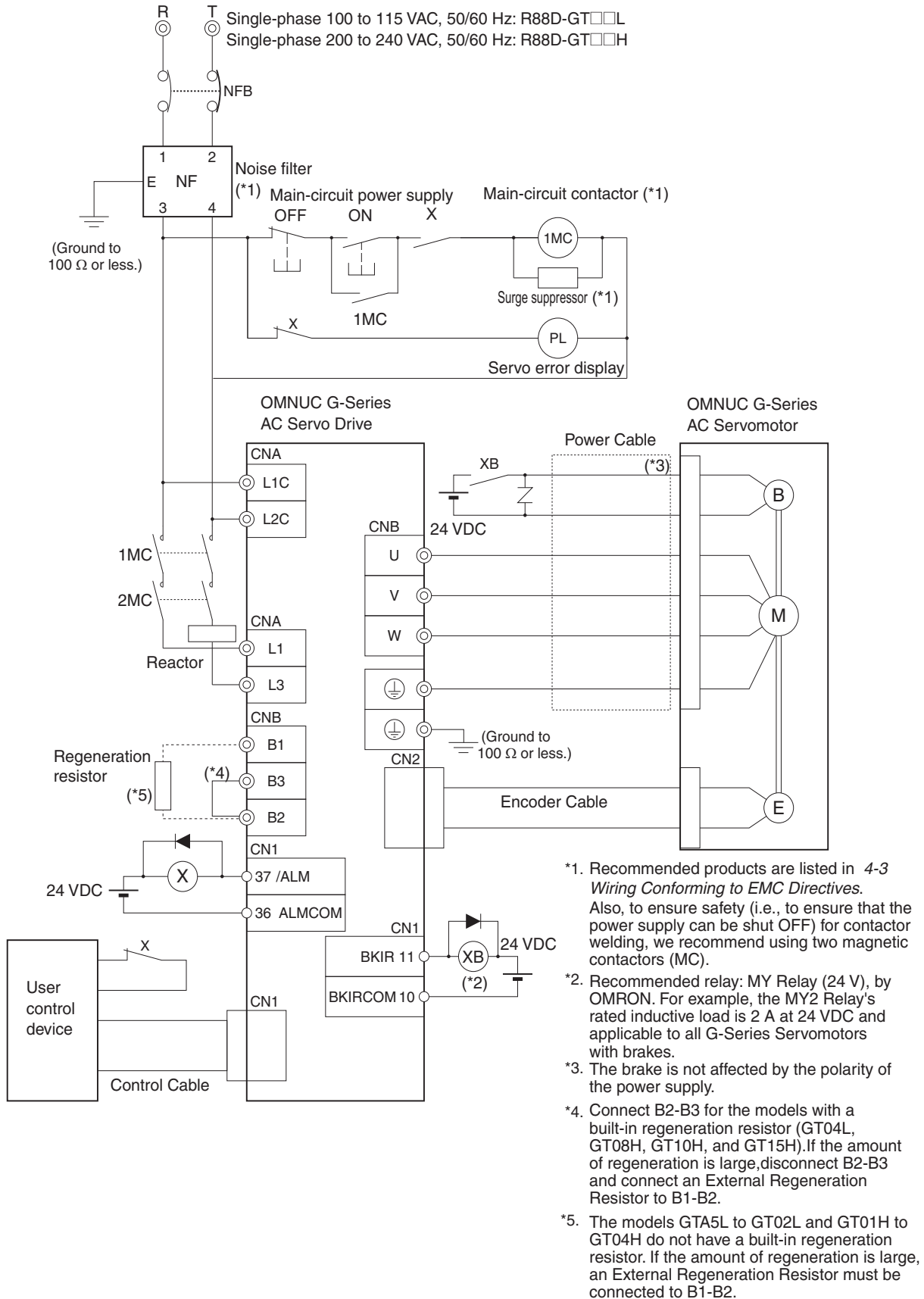

4

System Design

■ R88D-GT08H/-GT10H/-GT15H

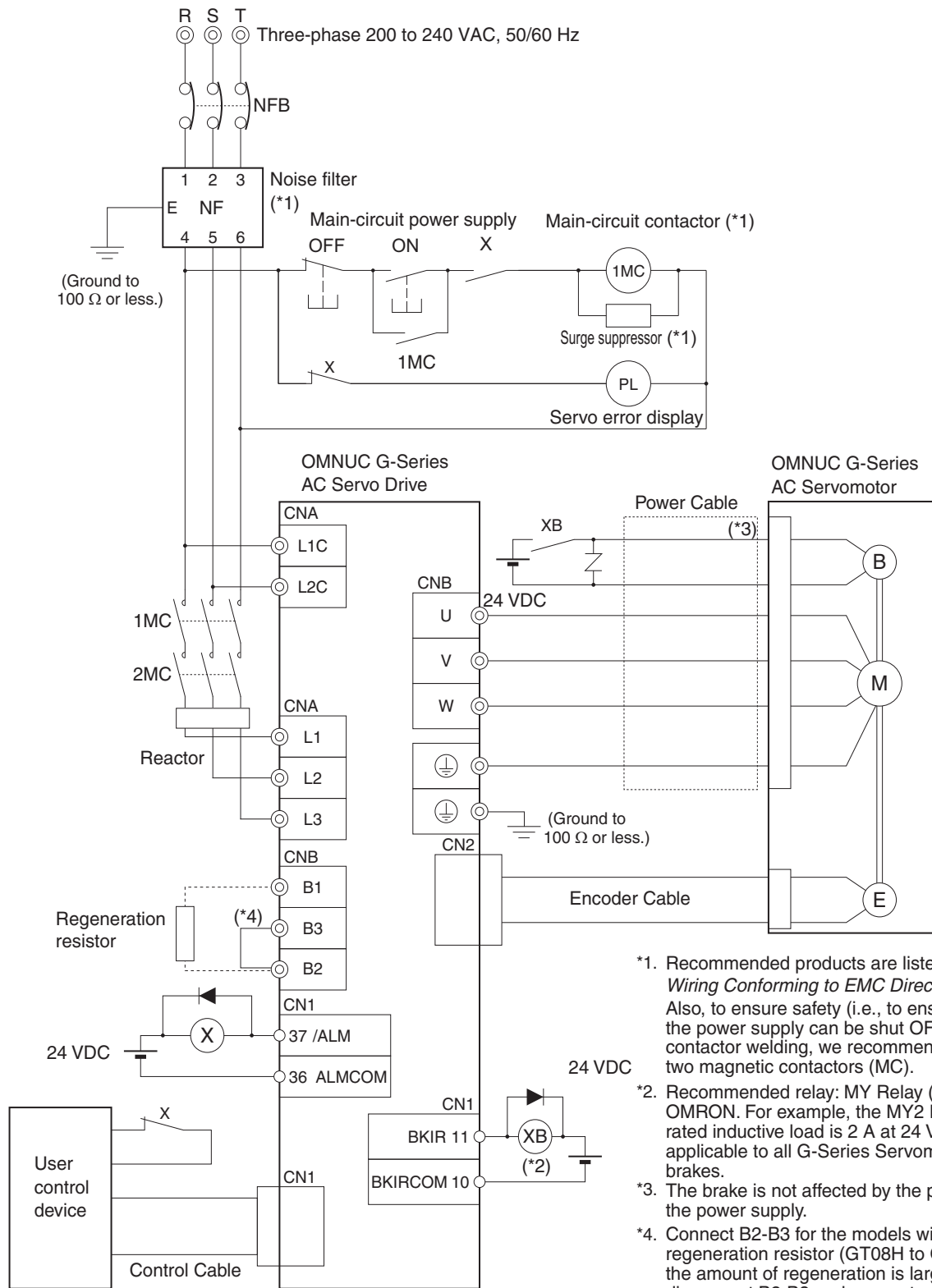

- \*1. Recommended products are listed in 4-3 *Wiring Conforming to EMC Directives*. Also, to ensure safety (i.e., to ensure that the power supply can be shut OFF) for contactor welding, we recommend using two magnetic contactors (MC).
- \*2. Recommended relay: MY Relay (24 V), by OMRON. For example, the MY2 Relay's rated inductive load is 2 A at 24 VDC and applicable to all G-Series Servomotors with brakes.
- \*3. The brake is not affected by the polarity of the power supply.
- \*4. Connect B2-B3 for the models with a built-in regeneration resistor (GT08H to GT15H). If the amount of regeneration is large, disconnect B2-B3 and connect an External Regeneration Resistor to B1-B2.

■ R88D-GT20H/-GT30H/-GT50H

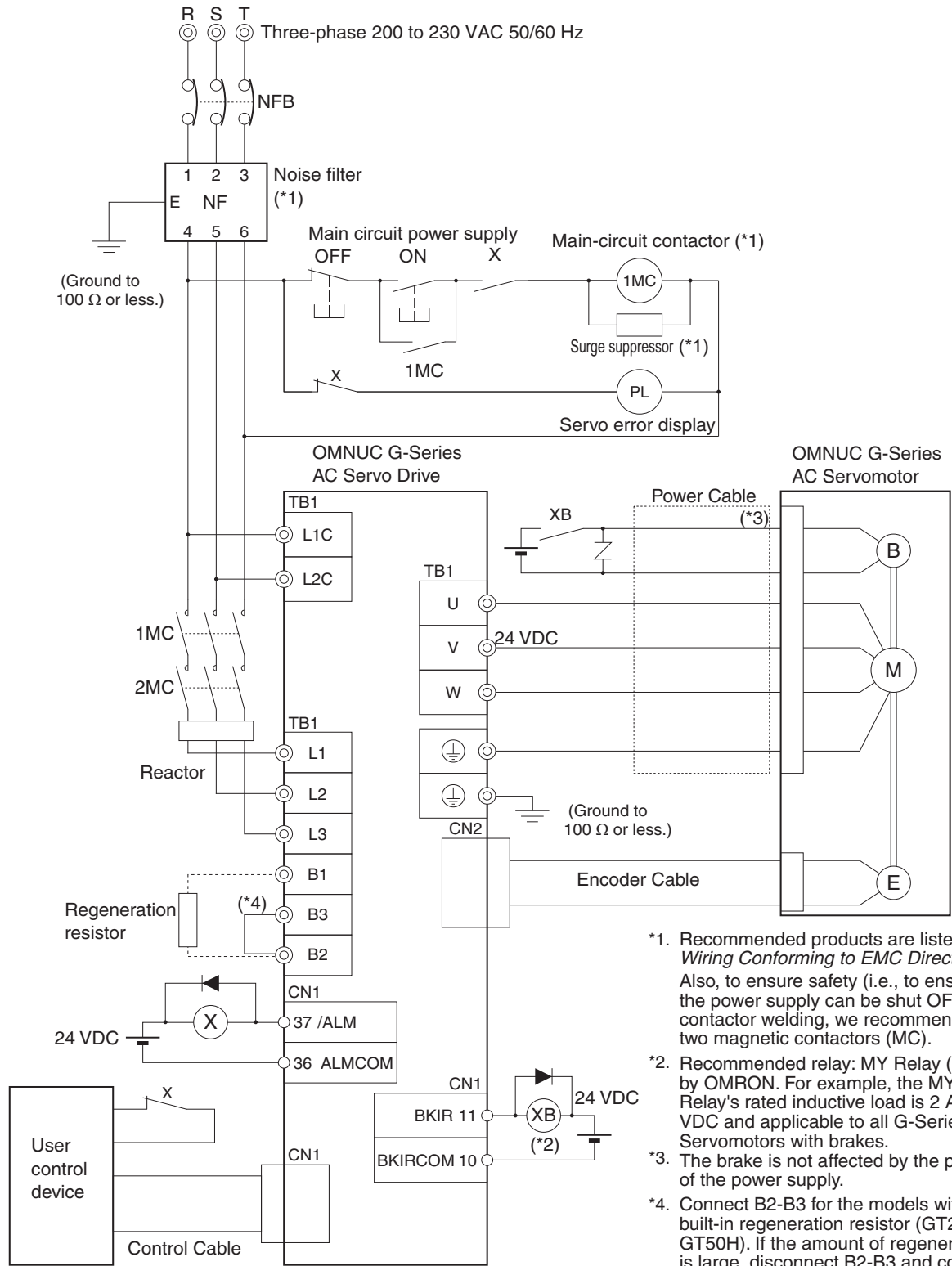

- \*1. Recommended products are listed in 4-3 *Wiring Conforming to EMC Directives*. Also, to ensure safety (i.e., to ensure that the power supply can be shut OFF) for contactor welding, we recommend using two magnetic contactors (MC).
- \*2. Recommended relay: MY Relay (24 V), by OMRON. For example, the MY2 Relay's rated inductive load is 2 A at 24 VDC and applicable to all G-Series Servomotors with brakes.
- \*3. The brake is not affected by the polarity of the power supply.
- \*4. Connect B2-B3 for the models with a built-in regeneration resistor (GT20H to GT50H). If the amount of regeneration is large, disconnect B2-B3 and connect an External Regeneration Resistor to B1-B2.

4

System Design



■ R88D-GT75H

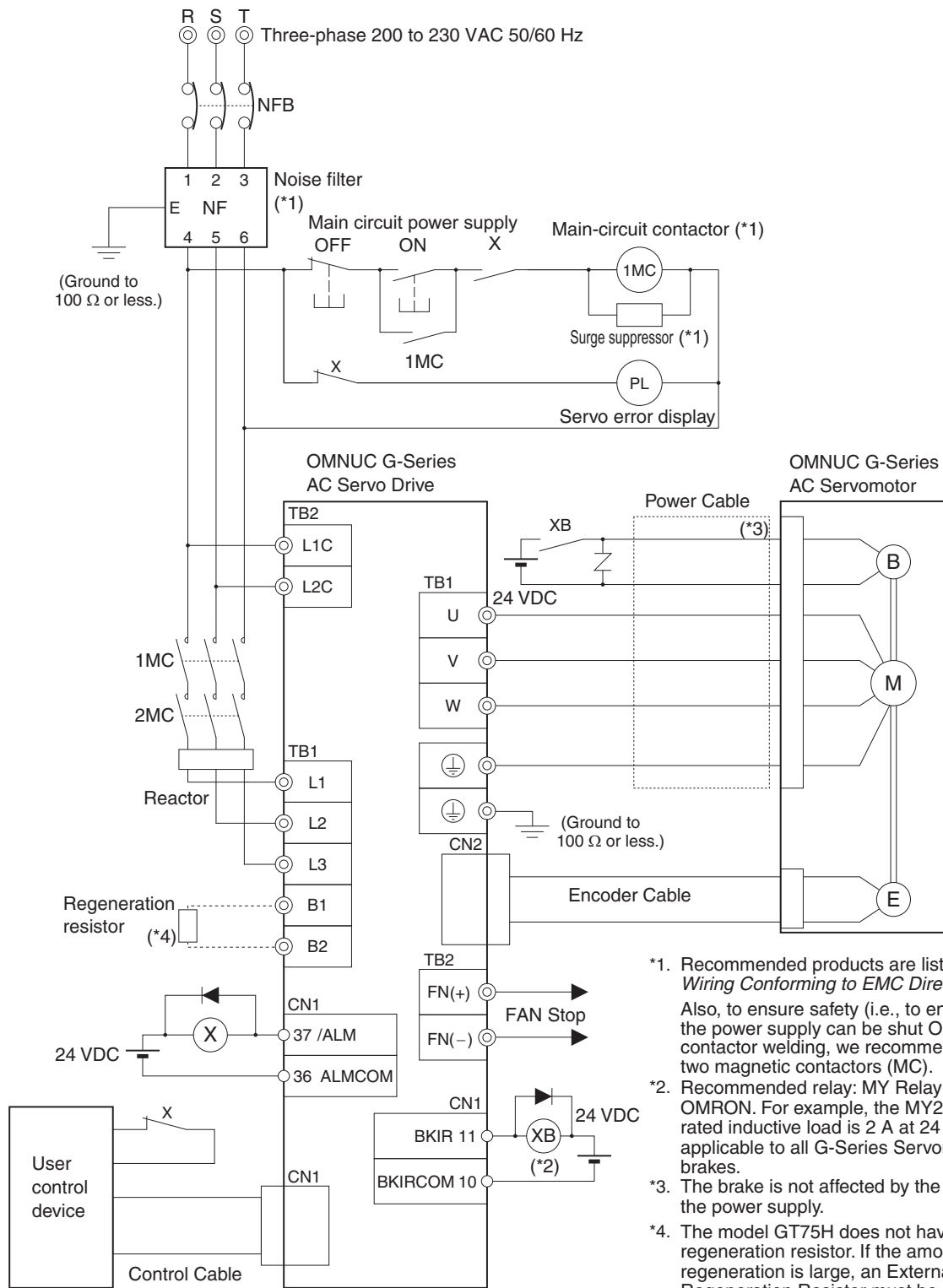

- \*1. Recommended products are listed in 4-3 Wiring Conforming to EMC Directives. Also, to ensure safety (i.e., to ensure that the power supply can be shut OFF) for contactor welding, we recommend using two magnetic contactors (MC).
- \*2. Recommended relay: MY Relay (24 V), by OMRON. For example, the MY2 Relay's rated inductive load is 2 A at 24 VDC and applicable to all G-Series Servomotors with brakes.
- \*3. The brake is not affected by the polarity of the power supply.
- \*4. The model GT75H does not have a built-in regeneration resistor. If the amount of regeneration is large, an External Regeneration Resistor must be connected to B1-B2.

## Main Circuit and Servomotor Connections

When wiring the main circuit, use proper wire sizes, grounding systems, and anti-noise measures.

### ■ R88D-GTA5L/-GT01L/-GT02L/-GT04L R88D-GT01H/-GT02H/-GT04H/-GT08H/-GT10H/-GT15H

#### Main Circuit Connector Specifications (CNA)

Symbol	Name	Description
L1	Main circuits power supply input	R88D-GT□L (50 W to 400 W): Single-phase 100 to 115 VAC (85 to 127 V), 50/60 Hz
L2		R88D-GT□H (50 W to 1.5 kW): Single-phase 200 to 240 VAC (170 to 264 V), 50/60 Hz
L3		R88D-GT□H (750 W to 1.5 kW): Three-phase 200 to 240 VAC (170 to 264 V), 50/60 Hz
L1C	Control circuit power supply input	R88D-GT□L: Single-phase 100 to 115 VAC (85 to 127 V), 50/60 Hz
L2C		R88D-GT□H: Single-phase 200 to 240 VAC (170 to 264 V), 50/60 Hz

#### Servomotor Connector Specifications (CNB)

Symbol	Name	Description
B1	External Regeneration Resistor connection terminals	R88D-GTA5L/-GT01L/-GT02L/-GT01H/-GT02H/-GT04H: These terminals normally do not need to be connected. If there is high regenerative energy, connect an External Regeneration Resistor between B1 and B2.
B2		R88D-GT04L/-GT08H/-GT10H/-GT15H: Normally B2 and B3 are connected. If there is high regenerative energy, remove the short-circuit bar between B2 and B3 and connect an External Regeneration Resistor between B1 and B2.
B3		
U	Servomotor connection terminals	Red
V		White
W		Blue
⊕		Green/ Yellow
⊕	Frame ground	This is the ground terminal. Ground to a 100 Ω or less.

## ■ R88D-GT20H/-GT30H/-GT50H

### Main Circuit Terminal Block Specifications

Symbol	Name	Function	
L1	Main circuit power supply input	R88D-GT□H (2 to 5 kW): Three-phase 200 to 230 VAC (170 to 253 V), 50/60Hz	
L2			
L3			
L1C	Control circuit power supply input	R88D-GT□H: Single-phase 200 to 230 VAC (170 to 253 V), 50/60 Hz	
L2C			
B1	External Regeneration Resistor connection terminals	2 to 5 kW: Normally B2 and B3 are connected. Do not short B1 and B2. Doing so may cause malfunctions. If there is high regenerative energy, remove the short-circuit bar between B2 and B3 and connect an External Regeneration Resistor between B1 and B2.	
B2			
B3			
U	Servomotor connection terminals	Red	These are the output terminals to the Servomotor. Be sure to wire them correctly.
V		White	
W		Blue	
⊕		Green/ Yellow	
⊕	Frame ground	This is the ground terminal. Ground to 100 Ω or less.	

■ R88D-GT75H

**Main Circuit Terminal Block Specifications (TB1)**

Symbol	Name	Function	
L1	Main circuit power supply input	R88D-GT75H (6 to 7.5 kW): Three-phase 200 to 230 VAC (170 to 253 V), 50/60Hz	
L2			
L3			
B1	External Regeneration Resistor connection terminals	6 kW, 7.5 kW: A regeneration resistor is not built in. Connect an External Regeneration Resistor between B1 and B2, if necessary. Do not short B1 and B2. Doing so may cause malfunctions.	
B2			
U	Servomotor connection terminals	Red	These are the output terminals to the Servomotor. Be sure to wire them correctly.
V		White	
W		Blue	
⊕		Green/ Yellow	
⊕	Frame ground	This is the ground terminal. Ground to 100 Ω or less.	

**Main Circuit Terminal Block Specifications (TB2)**

Symbol	Name	Function
NC	---	Do not connect.
L1C	Control circuit power supply input	R88D-GT75H: Single-phase 200 to 230 VAC (170 to 253 V), 50/60Hz
L2C		
⊕	Frame ground	This is the ground terminal. Ground to 100 Ω or less.
NC	---	Do not connect.
EX1		
EX2		
EX3		
NC		
FN(+)	Fan Stop Output	Outputs a warning signal when the fan inside the Servo Drive stops. (30 VDC, 50 mA max).
FN(-)		

## ■ Terminal Block Wire Sizes

### 100-VAC Input: R88D-GT□□L

Model (R88D-)			GTA5L	GT01L	GT02L	GT04L
Item	Unit					
Power supply capacity	kVA		0.4	0.4	0.5	0.9
Main circuit power supply input (L1 and L3, or L1, L2, and L3) *1	Rated current	A	1.4	2.2	3.7	6.6
	Wire size	---	AWG18			AWG16
Control circuit power supply input (L1C and L2C)	Rated current	A	0.09	0.09	0.09	0.09
	Wire size	---	AWG18			
Servomotor connection terminals (U, V, W, and GR) *2	Rated current	A	1.2	1.7	2.5	4.6
	Wire size	---	AWG18			
Frame ground (GR)	Wire size	---	AWG14			
	Screw size	---	M4			
	Torque	N·m	1.2			

### 200-VAC Input: R88D-GT□□H

Model (R88D-)			GT01H	GT02H	GT04H	GT08H	GT10H
Item	Unit						
Power supply capacity	kVA		0.5	0.5	0.9	1.3	1.8
Main circuit power supply input (L1 and L3, or L1, L2, and L3) *1	Rated current	A	1.3	2.0	3.7	5.0/3.3 *1	7.5/4.1 *1
	Wire size	---	AWG18				AWG16
	Screw size	---	---	---	---	---	---
	Torque	N·m	---	---	---	---	---
Control circuit power supply input (L1C and L2C)	Rated current	A	0.05	0.05	0.05	0.05	0.07
	Wire size	---	AWG18				
	Screw size	---	---	---	---	---	---
	Torque	N·m	---	---	---	---	---
Servomotor connection terminals (U, V, W, and GR) *2	Rated current	A	1.2	1.6	2.6	4.0	5.8
	Wire size	---	AWG18				AWG16
	Screw size	---	---	---	---	---	---
	Torque	N·m	---	---	---	---	---
Frame ground (GR)	Wire size	---	AWG14				
	Screw size	---	M4				
	Torque	N·m	1.2				

Model (R88D-)		GT15H	GT20H	GT30H	GT50H	GT75H	
Item	Unit						
Power supply capacity	kVA	2.3	3.3	4.5	7.5	11	
Main circuit power supply input (L1 and L3, or L1, L2, and L3) *1	Rated current	A	11.0/8.0 *1	10.2	15.2	23.7	35.0
	Wire size	---	AWG14		AWG12	AWG10	AWG8
	Screw size	---	---	M5			
	Torque	N-m	---	2.0			
Control circuit power supply input (L1C and L2C)	Rated current	A	0.07	0.1	0.12	0.12	0.14
	Wire size	---	AWG18				
	Screw size	---	---	M5			
	Torque	N-m	---	2.0			
Servomotor connection terminals (U, V, W, and GR) *2	Rated current	A	9.4	13.4	18.6	33.0	47.0
	Wire size	---	AWG14		AWG12	AWG8	AWG6
	Screw size	---	---	M5			
	Torque	N-m	---	2.0			
Frame ground (GR)	Wire size	---	AWG14	AWG12		AWG8	
	Screw size	---	M4	M5			
	Torque	N-m	1.2	2.0			

\*1. The left value is for single-phase input power, and the right value is for three-phase input power.

\*2. Use the same wire sizes for B1 and B2.

\*3. Connect an OMRON Servomotor Power Cable to the Servomotor connection terminals.

■ Wire Sizes and Allowable Current (Reference)

The following table shows the allowable current when there are three power supply wires. Use a current below these specified values.

600-V Heat-resistant Vinyl Wire (HIV)

AWG size	Nominal cross-sectional area (mm <sup>2</sup> )	Configuration (wires/mm <sup>2</sup> )	Conductive resistance (Ω/km)	Allowable current (A) for ambient temperature		
				30°C	40°C	50°C
20	0.5	19/0.18	39.5	6.6	5.6	4.5
---	0.75	30/0.18	26.0	8.8	7.0	5.5
18	0.9	37/0.18	24.4	9.0	7.7	6.0
16	1.25	50/0.18	15.6	12.0	11.0	8.5
14	2.0	7/0.6	9.53	23	20	16
12	3.5	7/0.8	5.41	33	29	24
10	5.5	7/1.0	3.47	43	38	31
8	8.0	7/1.2	2.41	55	49	40
6	14.0	7/1.6	1.35	79	70	57

## ■ Terminal Block Wiring Procedure

Connector-type Terminal Blocks are used for Servo Drives of 1.5 kW or less (R88D-GTA5L to GT15H). The procedure for wiring these Terminal Blocks is explained below.

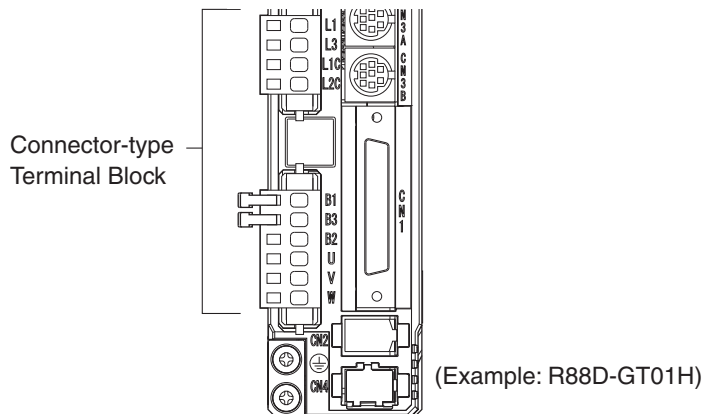

### 1. Remove the Terminal Block from the Servo Drive before wiring.

The Servo Drive will be damaged if the wiring is done with the Terminal Block in place.

### 2. Strip off 8 to 9 mm of the covering from the end of each wire.

Refer to *Terminal Block Wire Sizes* on page 4-24 for applicable wire sizes.

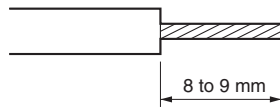

### 3. Open the wire insertion slots in the Terminal Block

There are two ways to open the wire insertion slots, as follows:

- Pry the slot open using the lever that comes with the Servo Drive (as in Fig. A).
- Insert a flat-blade screwdriver (end width: 3.0 to 3.5 mm) into the opening for the screwdriver, and press down firmly to open the slot (as in Fig. B).

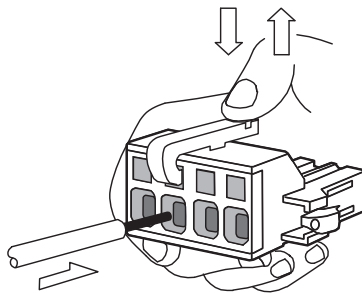

Fig. A

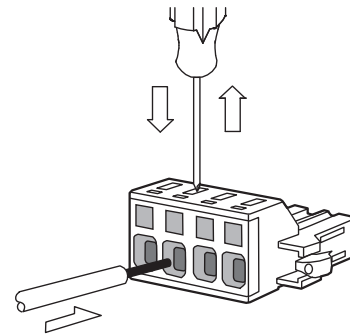

Fig. B

### 4. With the slot held open, insert the end of the wire.

After inserting the wire, let the slot close by releasing the pressure from the lever or the screwdriver.

### 5. Mount the Terminal Block to the Servo Drive.

After all of the terminals have been wired, return the Terminal Block to its original position on the Servo Drive.

## 4-3 Wiring Conforming to EMC Directives

Conformance to the EMC Directives (EN 55011 Class A Group 1 (EMI) and EN 61000-6-2 (EMS)) can be ensured by wiring under the conditions described below. These conditions are for conformance of OMNUC G-Series products to the EMC Directives.

EMC-related performance of these products, however, depends on the configuration, wiring, and other conditions of the equipment in which the products are installed. The EMC conformance of the system as a whole must be confirmed by the customer.

The following are the requirements for EMC Directive conformance.

- The Servo Drive must be installed in a metal case (control panel). (The Servomotor does not, however, have to be covered with a metal plate.)
- Noise filters and surge absorbers must be installed on power supply lines.
- Shielded cables must be used for all I/O signal lines and encoder lines. (Use tin-plated, mild steel wires for the shielding.)
- All cables, I/O wiring, and power lines connected to the Servo Drive must have clamp filters installed.
- The shields of all cables must be directly connected to a ground plate.

### Wiring Method

**R88D-GTA5L/-GT01L/-GT02L/-GT04L/-GT01H/-GT02H/-GT04H/-GT08H/-GT10H/-GT15H/-GT20H/-GT30H/-GT50H**

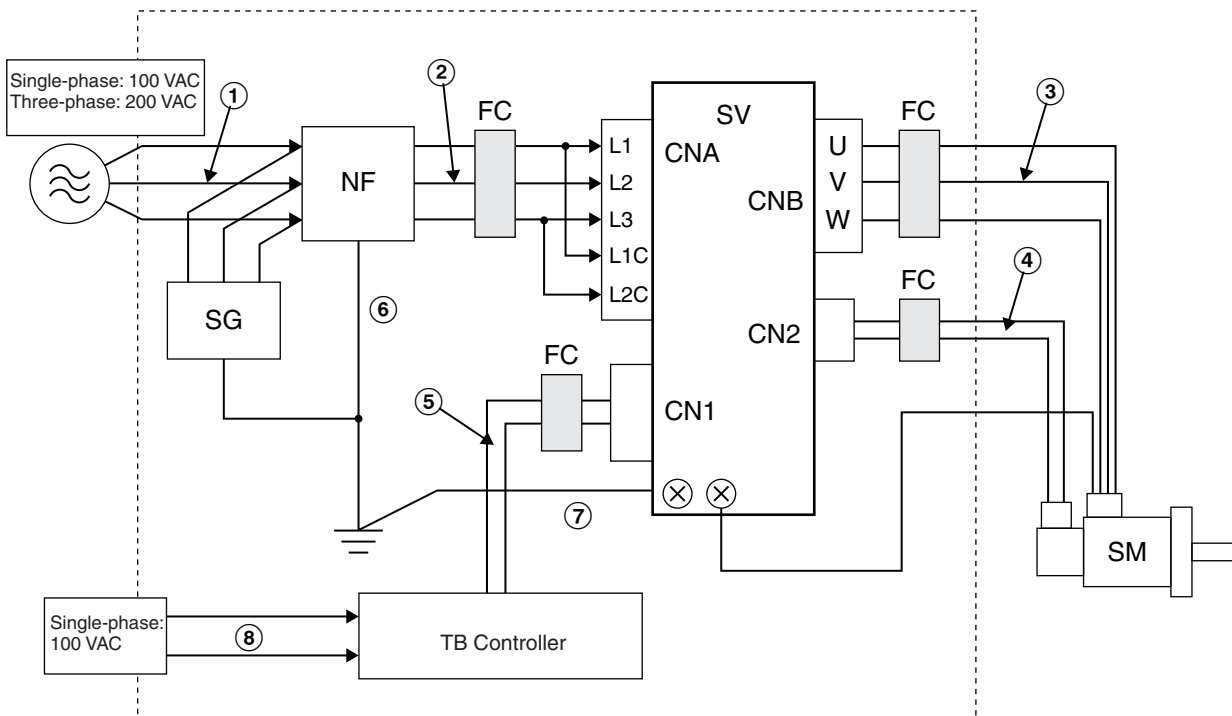

\*1. For models with a single-phase power supply input (R88D-GTA5L/-GT01L/-GT02L/-GT04L/-GT01H/-GT02H/-GT04H/-GT08H), the main circuit power supply input terminals are L1 and L3.

- Ground the motor's frame to the machine ground when the motor is on a movable shaft.
- Use a ground plate for the frame ground for each Unit, as shown in the above diagrams, and ground to a single point.
- Use ground lines with a minimum thickness of 3.5 mm<sup>2</sup>, and arrange the wiring so that the ground lines are as short as possible.



- No-fuse breakers, surge absorbers, and noise filters should be positioned near the input terminal block (ground plate), and I/O lines should be separated and wired at the shortest distance.

### R88D-GT75H

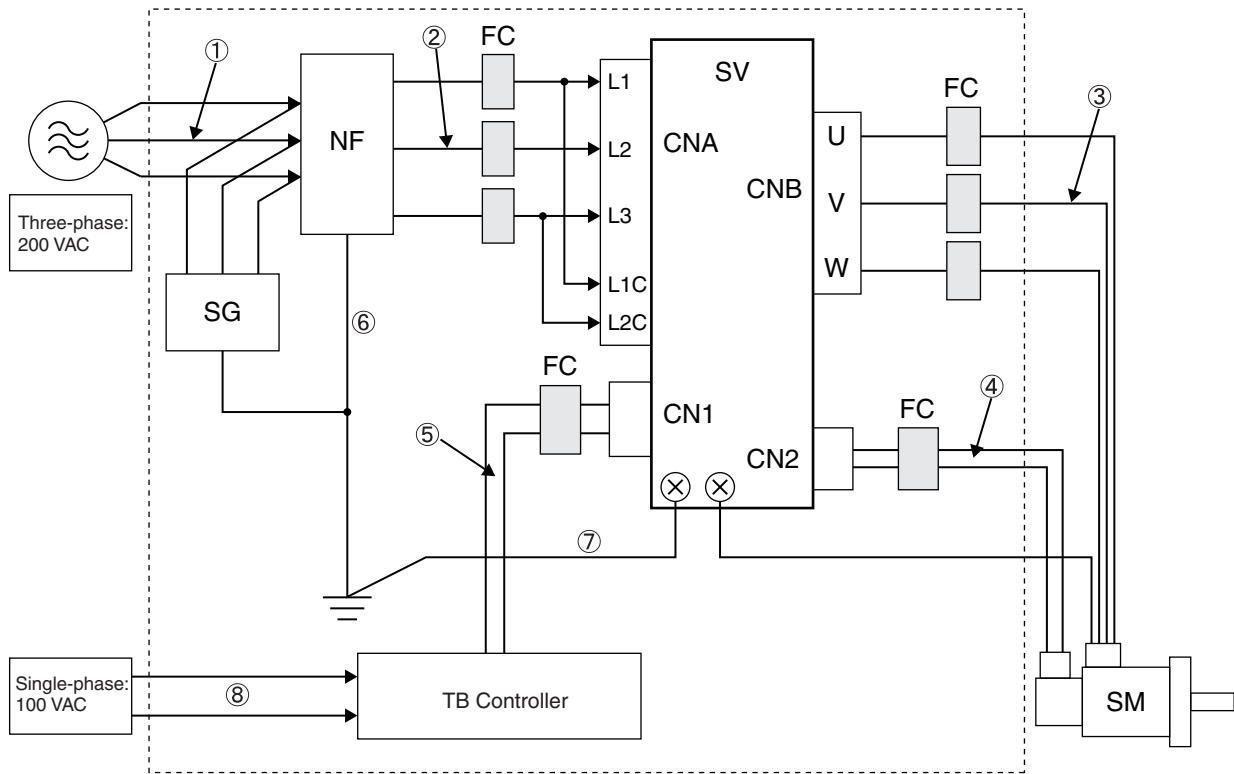

### Unit Details

Symbol	Name	Manufacturer	Model	Remarks
SG	Surge absorber	Okaya Electric Industries Co., Ltd.	RAV781BWZ-4	Single-phase 100 VAC
			RAV781BXZ-4	Three-phase 200 VAC
NF	Noise filter	Okaya Electric Industries Co., Ltd.	SPU-EK5-ER-6	Single-phase 100/200 VAC (5 A)
			3SUP-HQ10-ER-6	Three-phase 200 VAC (10 A)
			3SUP-HU30-ER-6	Three-phase 200 VAC (30 A)
			3SUP-HL50-ER-6B	Three-phase 200 VAC (50 A)
SV	Servo Drive	OMRON Corp.	---	*1
SM	Servomotor	OMRON Corp.	---	*1
FC	Clamp core	TDK	ZCAT3035-1330	---
TB	Controller	---	---	Switch box

\*1. A specified combination of Servo Drive and Servomotor must be used.

### Cable Details

Symbol	Supplies from	Connects to	Cable name	Length	Remarks	Shielded	Ferrite
①	AC power supply	Noise filter	Power supply line	2 m	Three-phase 200 VAC	No	No
②	Noise filter	Servo Drive	Power supply line	2 m	---	No	Yes
③	Servo Drive	Servomotor	Power cable	20 m	---	Yes	Yes
④	Servo Drive	Servomotor	Encoder cable	20 m	---	No	Yes
⑤	Switch box	Servo Drive	I/O cable	2 m	---	No	Yes
⑥	Frame ground	Noise filter	Frame ground line	1.5 m	---	No	No
⑦	Frame ground	Noise filter	Frame ground line	1.5 m	---	No	No
⑧	AC power supply	Switch box	Power supply line	1.5 m	---	No	No

### ■ Noise Filters for Power Supply Input

Use the following noise filters for the Servo Drive power supply

Servo Drive model	Noise Filter				
	Model	Rated current	Phases	Maximum leakage current (60 Hz)	Manufacturer
R88D-GTA5L	SUP-EK5-ER-6	5 A	Single	1.0 mA (at 250 VAC)	Okaya Electric Industries Co., Ltd.
R88D-GT01L					
R88D-GT02L					
R88D-GT04L	3SUP-HQ10-ER-6	10 A	Three	3.5 mA (at 500 VAC)	
R88D-GT01H	SUP-EK5-ER-6	5 A	Single	1.0 mA (at 250 VAC)	
R88D-GT02H					
R88D-GT04H					
R88D-GT08H	3SUP-HQ10-ER-6	10 A	Three	3.5 mA (at 500 VAC)	
R88D-GT10H	3SUP-HU30-ER-6	30 A	Three	3.5 mA (at 500 VAC)	
R88D-GT15H					
R88D-GT20H					
R88D-GT30H	3SUP-HL50-ER-6B	50 A	Three	8.0 mA (at 500 VAC)	
R88D-GT50H					
R88D-GT75H					

- If no-fuse breakers are installed at the top and the power supply line is wired from the lower duct, use metal tubes for wiring or make sure that there is adequate distance between the input lines and the internal wiring. If input and output lines are wired together, noise resistance will decrease.
- Wire the noise filter as shown at the left in the following illustration. The noise filter must be installed as close as possible to the entrance of the control box.

### ○ Correct: Separate input and output

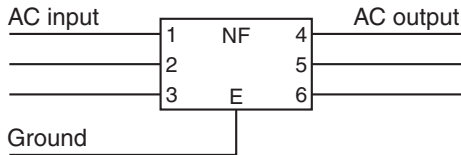

### ✗ Wrong: Noise not filtered effectively

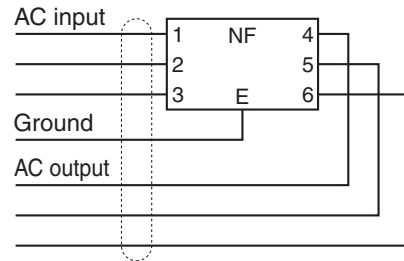

- Use twisted-pair cables for the power supply cables, or bind the cables.

### ○ Correct: Properly twisted

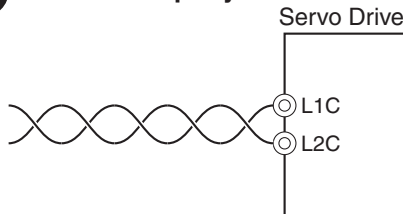

### ○ Correct: Cables are bound.

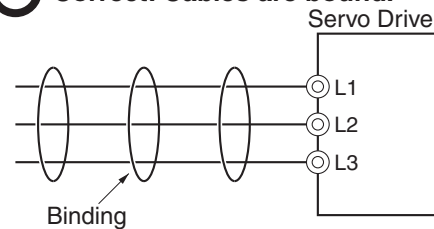

- Separate power supply cables and signal cables when wiring.

## ■ Control Panel Structure

Openings in the control panel, such as holes for cables, operating panel mounting holes, and gaps around the door, may allow electromagnetic waves into the panel. To prevent this, observe the recommendations described below when designing or selecting a control panel.

### Case Structure

- Use a metal control panel with welded joints at the top, bottom, and sides so that the surfaces will be electrically conductive.
- If assembly is required, strip the paint off the joint areas (or mask them during painting), to make them electrically conductive.
- The panel may warp and gaps may appear when screws are tightened. Be sure that no gaps appear when tightening screws.
- Do not leave any conductive part unconnected.
- Ground all Units within the case to the case itself.

### Door Structure

- Use a metal door.
- Use a water-draining structure where the door and case fit together, and leave no gaps. (Refer to the diagrams on the next page.)
- Use a conductive gasket between the door and the case. (Refer to the diagrams on the next page.)
- Strip the paint off the sections of the door and case that will be in contact with the conductive gasket (or mask them during painting), so that they will be electrically conductive.
- The panel may warp and gaps may appear when screws are tightened. Be sure that no gaps appear when tightening screws.

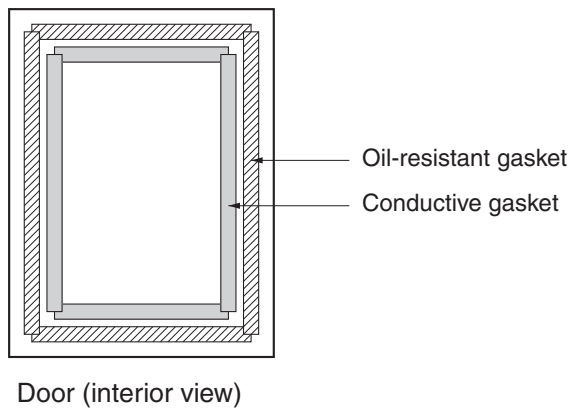
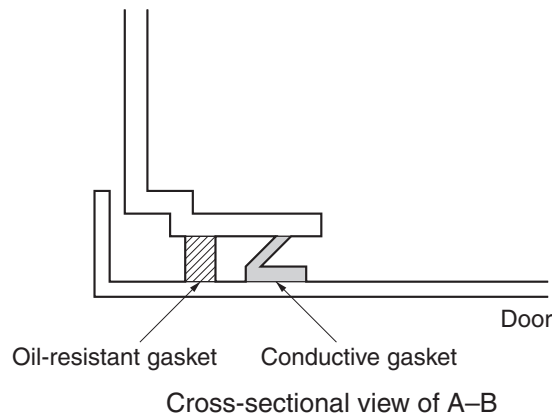
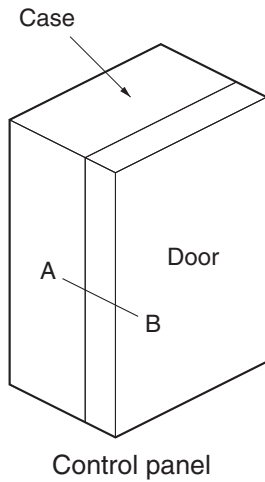

## Selecting Connection Components

This section explains the criteria for selecting the connection components required to improve noise resistance. Understand each component's characteristics, such as its capacity, performance, and applicable conditions when selecting the components. For more details, contact the manufacturers directly.

### ■ No-fuse Breakers (NFB)

When selecting a no-fuse breaker, consider the maximum input current and the inrush current.

#### Maximum Input Current:

- The Servo Drive's maximum momentary output is approximately three times the rated output, and can be output for up to three seconds. Therefore, select no-fuse breakers with an operating time of at least five seconds at 300% of the rated current. General-purpose and low-speed no-fuse breakers are generally suitable.
- Select a no-fuse-breaker with a rated current greater than the total effective load current of all the Servomotors. The rated current of the power supply input for each Servomotor is provided in *Main Circuit and Servomotor Connections* on page 4-21.
- Add the current consumption of other controllers, and any other components, when selecting the NFB.

#### Inrush Current:

- The following table lists the Servo Drive inrush currents.
- With low-speed no-fuse breakers, an inrush current 10 times the rated current can flow for 0.02 second.
- When multiple Servo Drives are turned ON simultaneously, select a no-fuse-breaker with a 20-ms allowable current that is greater than the total inrush current, shown in the following table.

Servo Drive model	Inrush current (Ao-p)	
	Main circuit power supply	Control circuit power supply
R88D-GTA5L	7	14
R88D-GT01L	7	14
R88D-GT02L	7	14
R88D-GT04L	30	14
R88D-GT01H	14	28
R88D-GT02H	14	28
R88D-GT04H	14	28
R88D-GT08H	60	28
R88D-GT10H	29	28
R88D-GT15H	29	28
R88D-GT20H	29	14
R88D-GT30H	22	14
R88D-GT50H	22	14
R88D-GT75H	88	66

### ■ Leakage Breakers

- Select leakage breakers designed for protection against grounding faults.
- Because switching takes place inside the Servo Drives, high-frequency current leaks from the switching elements of the Servo Drive, the armature of the motor, and the cables. High-frequency breakers with surge withstand capability do not detect high-frequency current, preventing the breaker from operating with high-frequency leakage current. When using a general-purpose leakage breaker, use three times the sum of the leakage current given in the following table as a reference value.
- When selecting leakage breakers, remember to add the leakage current from devices other than the Servomotor, such as machines using a switching power supply, noise filters, inverters, and so on. To prevent malfunction due to inrush current, we recommend using a leakage breaker of ten times the total of all leakage current values.
- The leakage breaker is activated at 50% of the rated current. Allow leeway when selecting a leakage breaker.
- For details on leakage breakers, refer to the manufacturer's catalog.
- The following table shows the Servomotor leakage current for each Servo Drive model.

Servo Drive model	Input power	Leakage current (mA)		
		Resistance method Resistor plus capacitor	Clamping method (Measurement filter ON at H10K13283)	
			Motor cable length: 3 m	Motor cable length: 3 m
R88D-GTA5L	Single-phase 100 V	0.42 mA	0.33 mA	0.003 mA
R88D-GT01L	Single-phase 100 V	0.45 mA	0.35 mA	0.002 mA
R88D-GT02L	Single-phase 100 V	0.46 mA	0.35 mA	0.002 mA
R88D-GT04L	Single-phase 100 V	0.48 mA	0.35 mA	0.002 mA
R88D-GT01H	Single-phase 200 V	0.92 mA	1.04 mA	0.016 mA
R88D-GT02H	Single-phase 200 V	0.94 mA	1.06 mA	0.013 mA
R88D-GT04H	Single-phase 200 V	1.15 mA	1.13 mA	0.013 mA
R88D-GT08H	Single-phase 200 V	1.27 mA	1.09 mA	0.014 mA
R88D-GT10H	Single-phase 200 V	1.27 mA	1.19 mA	0.015 mA
R88D-GT15H	Single-phase 200 V	1.51 mA	1.20 mA	0.015 mA
R88D-GT08H	Three-phase 200 V	1.62 mA	0.98 mA	0.009 mA
R88D-GT10H	Three-phase 200 V	1.77 mA	1.03 mA	0.008 mA
R88D-GT15H	Three-phase 200 V	2.18 mA	1.04 mA	0.003 mA
R88D-GT20H	Three-phase 200 V	2.88 mA	1.08 mA	0.008 mA
R88D-GT30H	Three-phase 200 V	2.83 mA	1.15 mA	0.011 mA
R88D-GT50H	Three-phase 200 V	3.07 mA	1.14 mA	0.011 mA
R88D-GT75H	Three-phase 200 V	6.32 mA	1.23 mA	0.013 mA

**Note 1.** The above leakage current is for cases when Servomotor power cable length is 3 meters or shorter. (The leakage current depends on the power cable length and the insulation.)

**Note 2.** The resistor plus capacitor method provides a yardstick to measure the leakage current that may flow through the human body when the Servomotor or Servo Drive is not grounded correctly. The above leakage current is for normal temperature and humidity. (The leakage current depends on the temperature and humidity.)

■ Surge Absorbers

- Use surge absorbers to absorb lightning surge voltage and abnormal voltage from power supply input lines.
- When selecting surge absorbers, take into account the varistor voltage, the allowable surge current and the energy.
- For 200-VAC systems, use surge absorbers with a varistor voltage of 620 V.
- The surge absorbers shown in the following table are recommended.

Manufacturer	Model	Surge immunity		Type	Remarks
Okaya Electric Industries Co., Ltd.	R·A·V-781BWZ-4	700 V $\pm$ 20%	2500 A	Block	Single-phase 100/200 VAC
Okaya Electric Industries Co., Ltd.	R·A·V-781BXZ-4	700 V $\pm$ 20%	2500 A		Three-phase 200 VAC

**Note 1.** Refer to the manufacturers' documentation for operating details.

**Note 2.** The surge immunity is for a standard impulse current of 8/20  $\mu$ s. If pulses are wide, either decrease the current or change to a larger-capacity surge absorber.

Dimensions

Single-phase BWZ Series

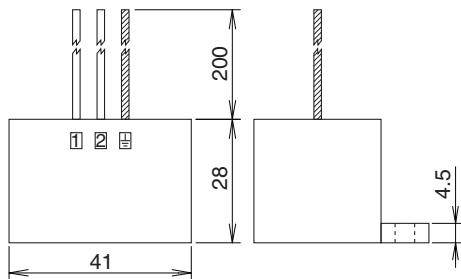
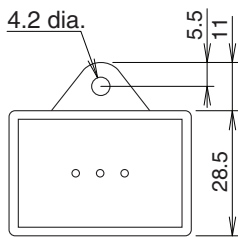

Three-phase BXZ Series

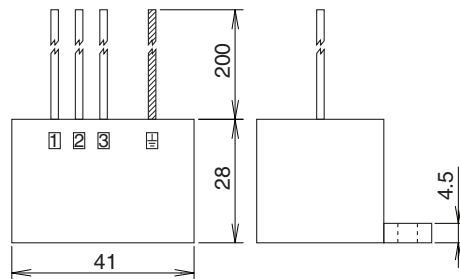
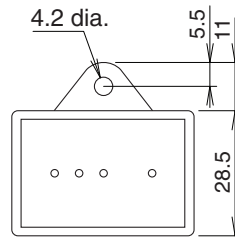

Equalizing Circuits

Single-phase BWZ Series

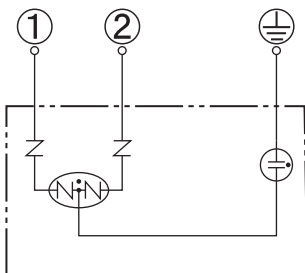

Three-phase BXZ Series

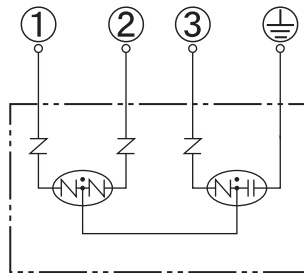

## 4-3 Wiring Conforming to EMC Directives

### ■ Noise Filters for the Power Supply Input

- Use the following noise filters for the Servo Drive's power supply.

Servo Drive model	Noise filter for the power supply Input			
	Model	Rated current	Max. leakage current (60 Hz)	Manufacturer
R88D-GTA5L	SUP-EK5-ER-6	5 A	1 mA (at 250 VAC)	Okaya Electric Industries Co., Ltd.
R88D-GT01L				
R88D-GT02L				
R88D-GT04L	3SUP-HQ10-ER-6	10 A	3.5 mA (at 500 VAC)	
R88D-GT01H	SUP-EK5-ER-6	5 A	1 mA (at 250 VAC)	
R88D-GT02H				
R88D-GT04H				
R88D-GT08H	3SUP-HQ10-ER-6	10 A	3.5 mA (at 500 VAC)	
R88D-GT10H	3SUP-HU30-ER-6	30 A	3.5 mA (at 500 VAC)	
R88D-GT15H				
R88D-GT20H				
R88D-GT30H	3SUP-HL50-ER-6B	50 A	8 mA (at 500 VAC)	
R88D-GT50H				
R88D-GT75H				

### Dimensions

SUP-EK5-ER-6

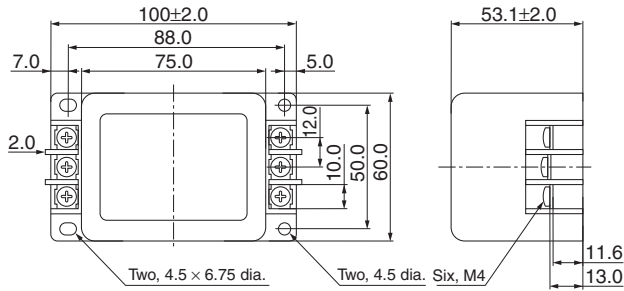

3SUP-HQ10-ER-6

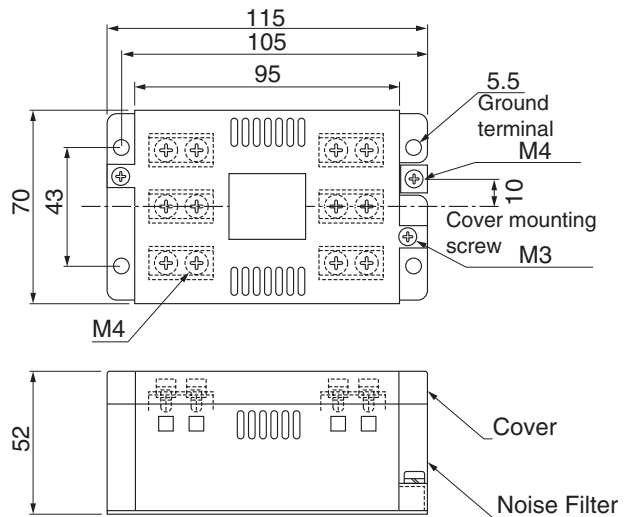



3SUP-HU30-ER-6

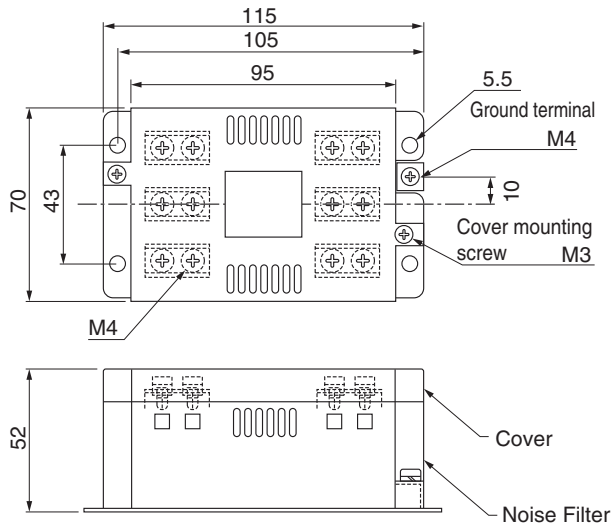

3SUP-HL50-ER-6B

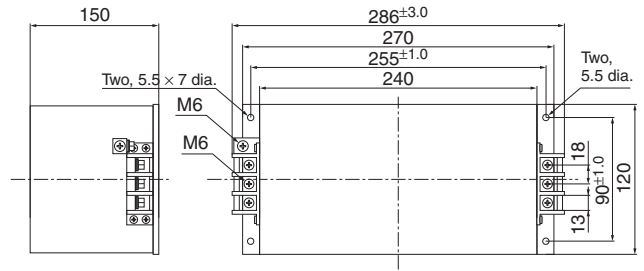

**Circuit Diagrams**

SUP-EK5-ER-6

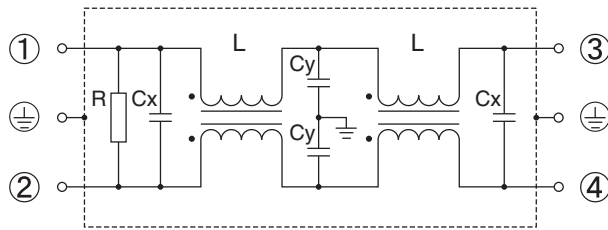

3SUP-HQ10-ER-6

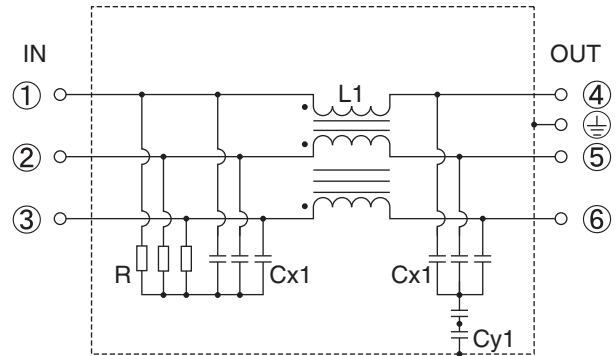

3SUP-HU30-ER-6

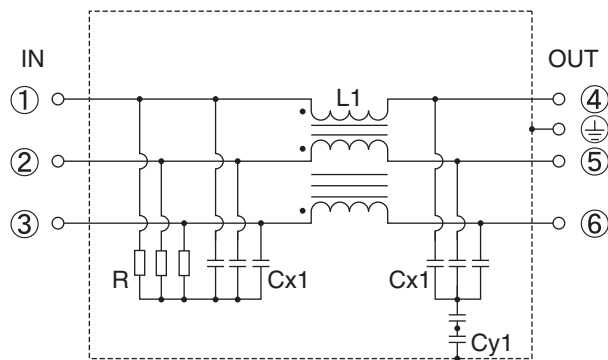

3SUP-HL50-ER-6B

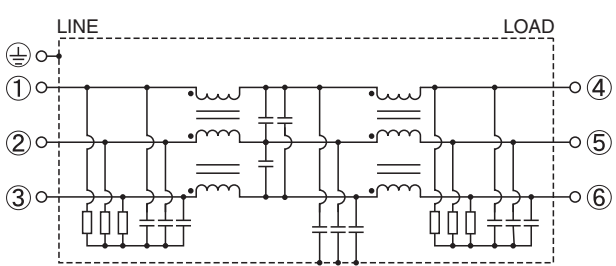

**■ Noise Filter for the Brake Power Supply**

- Use the following noise filter for the brake power supply.

Model	Rated current	Rated voltage	Leakage current	Manufacturer
SUP-EK5-ER-6	5 A	250 V	1.0 mA (at 250 Vrms, 60 Hz)	Okaya Electric Industries Co., Ltd.

**Note** Noise can also be reduced by using 1.5 turns with the ZCAT3035-1330 (TDK) Radio Noise Filter.

### Radio Noise Filters and Emission Noise Prevention Clamp Cores

Use one of the following filters to prevent switching noise of PWM of the Servo Drive and to prevent noise emitted from the internal oscillation circuit.

Model	Manufacturer	Application
3G3AX-ZCL1 <sup>*1</sup>	OMRON	Servo Drive output and power cable
3G3AX-ZCL2 <sup>*2</sup>	OMRON	Servo Drive output and power cable
ESD-R-47B <sup>*3</sup>	NEC TOKIN	Servo Drive output and power cable
ZCAT3035-1330 <sup>*4</sup>	TDK	Encoder cable and I/O cable

\*1. Generally used for 1.5 W or higher.

\*2. Generally used for 1.5 W or lower. The maximum number of windings is three turns.

\*3. Generally used for 50/100 W. The maximum number of windings is two turns.

\*4. Also used on the Servo Drive output power lines to comply with the EMC Directives. Only a clamp is used. This clamp can also be used to reduce noise current on a frame ground line.

#### Dimensions

3G3AX-ZCL1

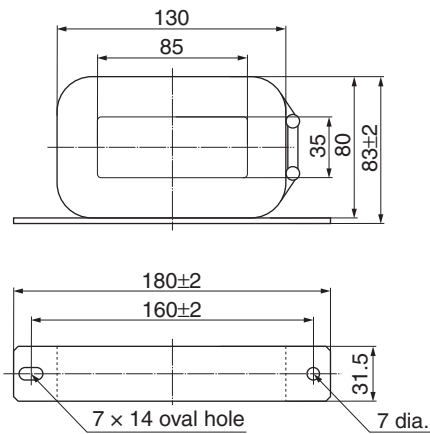

3G3AX-ZCL2

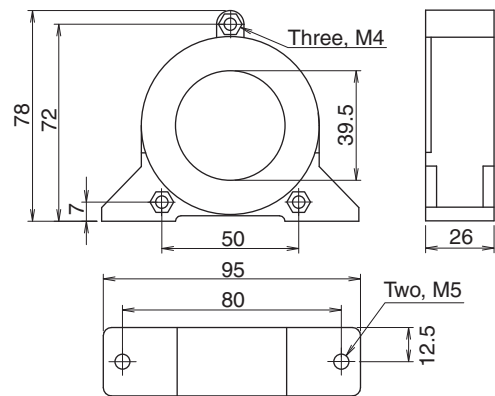

ESD-R-47B

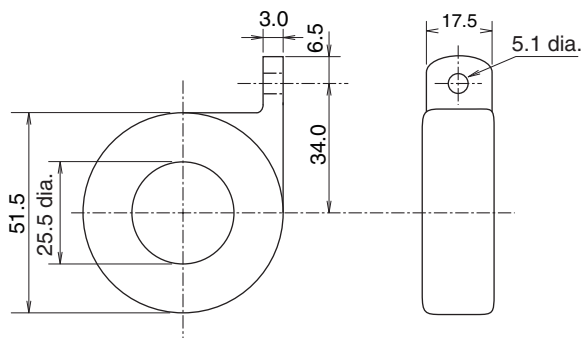

ZCAT 3035-1330

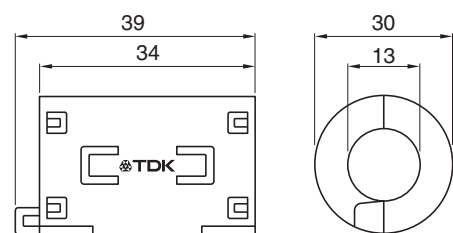

**Impedance Characteristics**

3G3AX-ZCL1

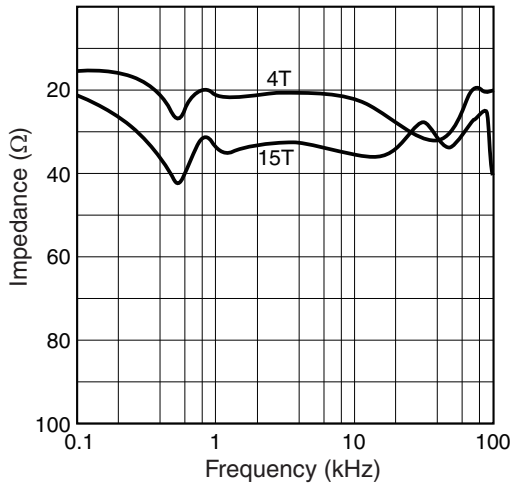

3G3AX-ZCL2

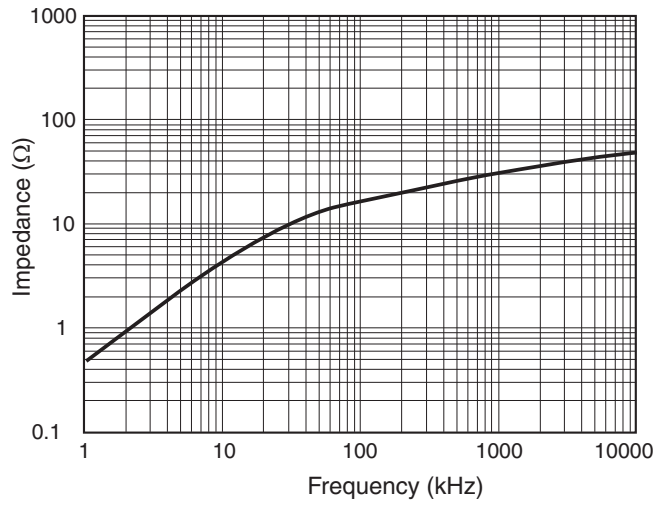

ESD-R-47B

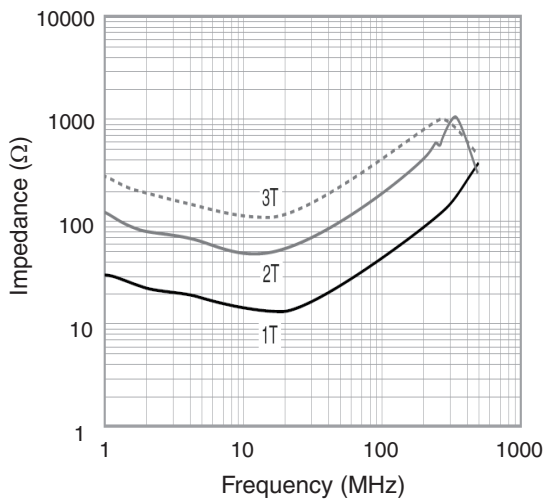

ZCAT 3035-1330

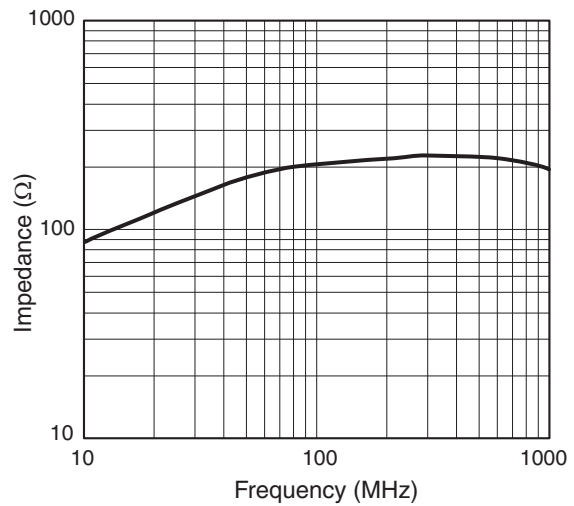

### ■ Surge Suppressors

- Install surge suppressors for loads that have induction coils, such as relays, solenoids, brakes, clutches, etc.
- The following table shows the types of surge suppressors and recommended products.

Type	Features	Recommended products
Diode	Diodes are used for relatively small loads when the reset time is not an issue, such as relays. At power shutoff the surge voltage is the lowest, but the rest time takes longer. Used for 24/48-VDC systems.	Use a fast-recovery diode with a short reverse recovery time (e.g. RU2 of Sanken Electric Co., Ltd.).
Thyristor or varistor	Thyristors and varistors are used for loads when induction coils are large, as in electromagnetic brakes, solenoids, etc., and when reset time is an issue. The surge voltage at power shutoff is approximately 1.5 times the varistor voltage.	Select the varistor voltage as follows: 24 VDC system: 39 V 100 VDC system: Varistor V. 200 V 100 VAC system: Varistor V. 270 V 200 VAC system: Varistor V. 470 V
Capacitor + resistor	The capacitor plus resistor combination is used to absorb vibration in the surge at power shutoff. The reset time can be shortened by selecting the appropriate capacitance and resistance.	Okaya Electric Industries Co., Ltd. XEB12002 0.2 $\mu$ F - 120 $\Omega$ XEB12003 0.3 $\mu$ F - 120 $\Omega$

- Thyristors and varistors are made by the following companies. Refer to manufacturers' documentation for details on these components.  
Thyristors: Ishizuka Electronics Co.  
Varistors: Ishizuka Electronics Co., Matsushita Electric Industrial Co.

### ■ Contactors

- Select contactors based on the circuit's inrush current and the maximum momentary phase current.
- The Servo Drive inrush current is covered in the preceding explanation of no-fuse breaker selection, and the maximum momentary phase current is approximately twice the rated current.
- The following table shows the recommended contactors.

Manufacturer	Model	Rated current	Coil voltage
OMRON	J7L-09-22200	11 A	200 VAC
	J7L-12-22200	13 A	200 VAC
	J7L-18-22200	18 A	200 VAC
	J7L-32-22200	26 A	200 VAC
	J7L-40-22200	35 A	200 VAC
	J7L-50-22200	50 A	200 VAC
	J7L-65-22200	65 A	200 VAC
	J7L-75-22200	75 A	200 VAC

■ Improving Encoder Cable Noise Resistance

Take the following steps during wiring and installation to improve the encoder's noise resistance.

- Always use the specified Encoder Cables.
- If cables are joined midway, be sure to use connectors and do not remove more than 50 mm of the cable insulation. In addition, always use shielded cables.
- Do not coil cables. If cables are long and are coiled, mutual induction and inductance will increase and cause malfunctions. Always use cables fully extended.
- When installing noise filters for Encoder Cables, use clamp filters.
- The following table shows the recommended clamp filters.

Manufacturer	Product name	Model	Specifications
NEC TOKIN	Clamp Filters	ESD-SR-250	For cable diameter up to 13 mm
TDK	Clamp Filters	ZCAT3035-1330	For cable diameter up to 13 mm

- Do not place the Encoder Cable with the following cables in the same duct: Control Cables for brakes, solenoids, clutches, and valves.

Dimensions

ESD-SR-250

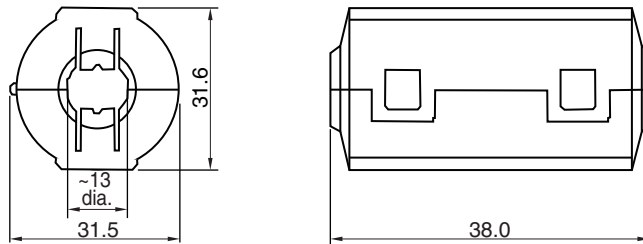

Impedance Characteristics

ESD-SR-250

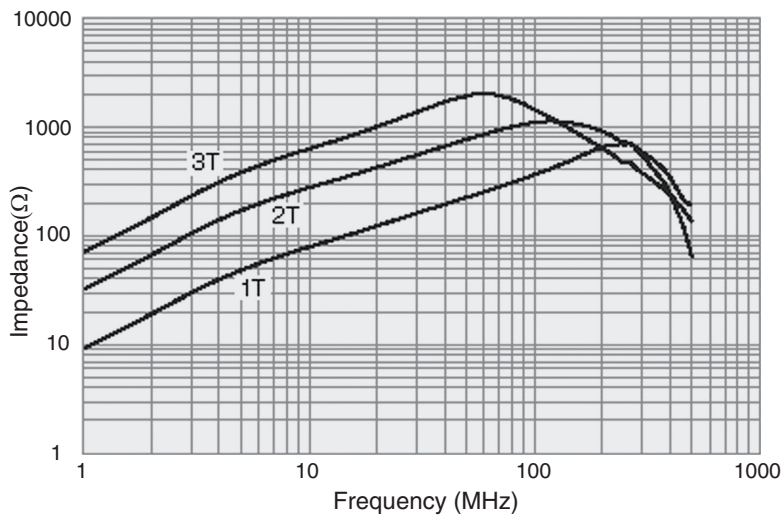

### ■ Improving Control I/O Signal Noise Resistance

Positioning can be affected and I/O signal errors can occur if control I/O is influenced by noise.

- Use completely separate power supplies for the control power supply (especially 24 VDC) and the external operation power supply. In particular, do not connect the two power supply ground wires.
- Install a noise filter on the primary side of the control power supply.
- If Servomotors with brakes are being used, do not use the same 24-VDC power supply for both the brakes and the control I/O. Additionally, do not connect the ground wires. Connecting the ground wires may cause I/O signal errors.
- Keep the power supply for pulse commands and deviation counter reset input lines separated from the control power supply as far as possible. In particular, do not connect the two power supply ground lines.
- We recommend using line drivers for the pulse command and deviation counter reset outputs.
- Always use twisted-pair shielded cable for the pulse command and deviation counter reset signal lines, and connect both ends of the shield to frame grounds.
- If the control power supply wiring is long, noise resistance can be improved by adding 1- $\mu$ F laminated ceramic capacitors between the control power supply and ground at the Servo Drive input section or the controller output section.
- For open-collector specifications, keep the length of wires to within two meters.

### ■ Reactors to Reduce Harmonic Current

#### Harmonic Current Countermeasures

- The Reactor is used for suppressing harmonic currents. It suppresses sudden and quick changes in electric currents.
- *The Guidelines for Suppressing Harmonic Currents in Home Appliances and General Purpose Components* requires that manufacturers take appropriate measures to suppress harmonic current emissions onto power supply lines.
- Select the proper Reactor model according to the Servo Drive to be used.

Servo Drive		Reactor							
Model	Number of power phases	Model	Rated current	Inductance	Weight				
R88D-GTA5L	Single-phase	3G3AX-DL2002	1.6 A	21.4 mH	Approx. 0.8 kg				
R88D-GT01L		3G3AX-DL2004	3.2 A	10.7 mH	Approx. 1.0 kg				
R88D-GT02L		3G3AX-DL2007	6.1 A	6.75 mH	Approx. 1.3 kg				
R88D-GT04L		3G3AX-DL2015	9.3 A	3.51 mH	Approx. 1.6 kg				
R88D-GT01H		3G3AX-DL2002	1.6 A	21.4 mH	Approx. 0.8 kg				
R88D-GT02H		3G3AX-DL2004	3.2 A	10.7 mH	Approx. 1.0 kg				
R88D-GT04H		3G3AX-DL2007	6.1 A	6.75 mH	Approx. 1.3 kg				
R88D-GT08H	Single-phase	3G3AX-DL2015	9.3 A	3.51 mH	Approx. 1.6 kg				
	3-phase	3G3AX-AL2025	10.0 A	2.8 mH	Approx. 2.8 kg				
R88D-GT10H	Single-phase	3G3AX-DL2015	9.3 A	3.51 mH	Approx. 1.6 kg				
	3-phase	3G3AX-AL2025	10.0 A	2.8 mH	Approx. 2.8 kg				
R88D-GT15H	Single-phase	3G3AX-DL2022	13.8 A	2.51 mH	Approx. 2.1 kg				
	3-phase	3G3AX-AL2025	10.0 A	2.8 mH	Approx. 2.8 kg				
R88D-GT20H	3-phase	3G3AX-AL2055	20.0 A	0.88 mH	Approx. 4.0 kg				
R88D-GT30H									
R88D-GT50H						3G3AX-AL2110	37.0 A	0.35 mH	Approx. 5.0 kg
R88D-GT75H						3G3AX-AL2220	70.0 A	0.18 mH	Approx. 10.0 kg

## ■ Selecting Other Parts for Noise Resistance

This section explains the criteria for selecting other connection components required to improve noise resistance.

Understand each component's characteristics, such as its capacity, performance, and applicable conditions when selecting the components.

For more details, contact the manufacturers directly.

### Noise Filters for the Power Supply Input

- Use a noise filter to attenuate external noise and reduce noise emitted from the Servo Drive.
- Select a noise filter with a rated current that is at least two times greater than the effective load current (the rated current of the main circuit power supply input given in *Main Circuit and Servomotor Connections* on page 4-21).

Manufacturer	Model	Rated current	Applicable standards	Remarks
NEC TOKIN	GT-2050	5 A	UL, CSA, VDE, TÜV	Single-phase
	GT-2100	10 A		
	GT-2150	15 A		
	GT-2150	20 A		
	HFP-2153	15 A	UL, CSA, TÜV	Three-phase
	HFP-2303	30 A		
Okaya Electric Industries Co., Ltd.	SUP-EK10-ER-6	10 A	UL, cUL, TÜV	Single-phase
	SUP-EK15-ER-6	15 A		
	SUP-EK20-ER-6	20 A		
	SUP-EK30-ER-6	30 A		
	SUP-HL10-ER-6	10 A	UL, TÜV	Three-phase
	SUP-H15-ER-6	15 A		
	3SUP-HL30-ER-6	30 A		
	3SUP-HL75-ER-6	75 A		
	3SUP-HL100-ER-6	100 A		
TDK	ZRCS2006-00S	6 A	UL, CSA, NEMKO	Single-phase
	ZRCS2010-00S	10 A		
	ZRCS2020-00S	20 A		
	ZRCS2030-00S	30 A		
	ZRCT5050-MF	50 A	UL, CSA, NEMKO	Three-phase
	ZRCT5080-MF	80 A		
	ZRCT5100-MF	100 A		

**Note 1.** To attenuate noise at low frequencies below 200 kHz, use an isolation transformer and a noise filter.

**Note 2.** To attenuate noise at high frequencies over 30 MHz, use a ferrite core and a high-frequency noise filter with a feed-through capacitor.

**Note 3.** If multiple Servo Drives are connected to a single noise filter, select a noise filter with a rated current at least two times the total rated current of all the Servo Drives.

### Noise Filters for Servomotor Output

- Use noise filters without built-in capacitors on the Servomotor output lines.
- Select a noise filter with a rated current at least two times the Servo Drive's continuous output current.
- The following table shows the noise filters that are recommended for Servomotor output.

Manufacturer	Model	Rated current	Remarks
OMRON	3G3AX-NF001	6 A	For inverter output
	3G3AX-NF002	12 A	
	3G3AX-NF003	25 A	
	3G3AX-NF004	50 A	
	3G3AX-NF005	75 A	
	3G3AX-NF006	100 A	

**Note 1.** Servomotor output lines cannot use the same noise filters for power supplies.

**Note 2.** Typical general-purpose noise filters are made for power supply frequencies of 50/60 Hz. If these noise filters are connected to the PWM output of the Servo Drive, a very large (about 100 times larger) leakage current will flow through the noise filter's condenser and the Servo Drive could be damaged.

### Dimensions

#### 3G3AX-NF001/-NF002

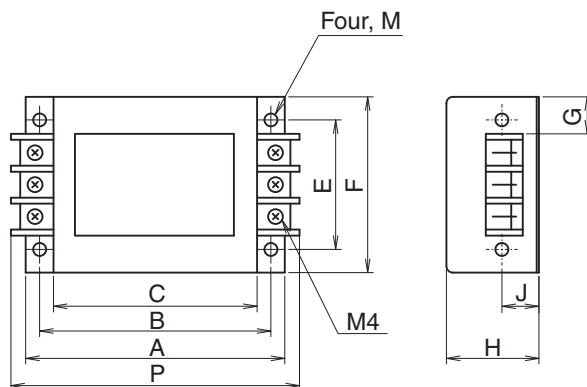

Model	Dimensions (mm)									
	A	B	C	E	F	G	H	J	M	P
3G3AX-NF001	140	125	110	70	95	22	50	20	4.5 dia.	156
3G3AX-NF002	160	145	130	80	110	30	70	25	5.5 dia.	176



3G3AX-NF003/-NF004/-NF005/-NF006

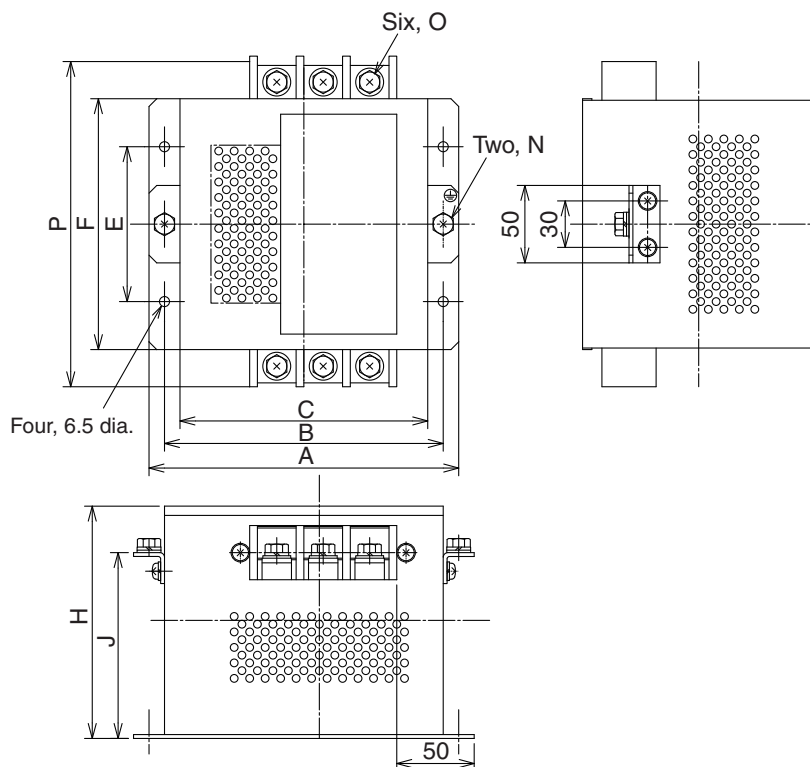

Model	Dimensions (mm)									
	A	B	C	E	F	H	J	N	O	P
3G3AX-NF003	160	145	130	80	112	120	---	---	M4	154
3G3AX-NF004	200	180	160	100	162	150	120	M5	M5	210
3G3AX-NF005	220	200	180	100	182	170	140	M6	M6	230
3G3AX-NF006	220	200	180	100	182	170	140	M8	M8	237

# 4-4 Regenerative Energy Absorption

The Servo Drives have internal regenerative energy absorption circuitry, which absorbs the regenerative energy produced during Servomotor deceleration and prevents the DC voltage from increasing. An overvoltage error occurs, however, if the amount of regenerative energy from the Servomotor is too large. If this occurs, measures must be taken to reduce the regenerative energy by changing operating patterns, or to increase the regenerative energy absorption capacity by connecting an External Regeneration Resistor.

4

## Calculating the Regenerative Energy

### Horizontal Axis

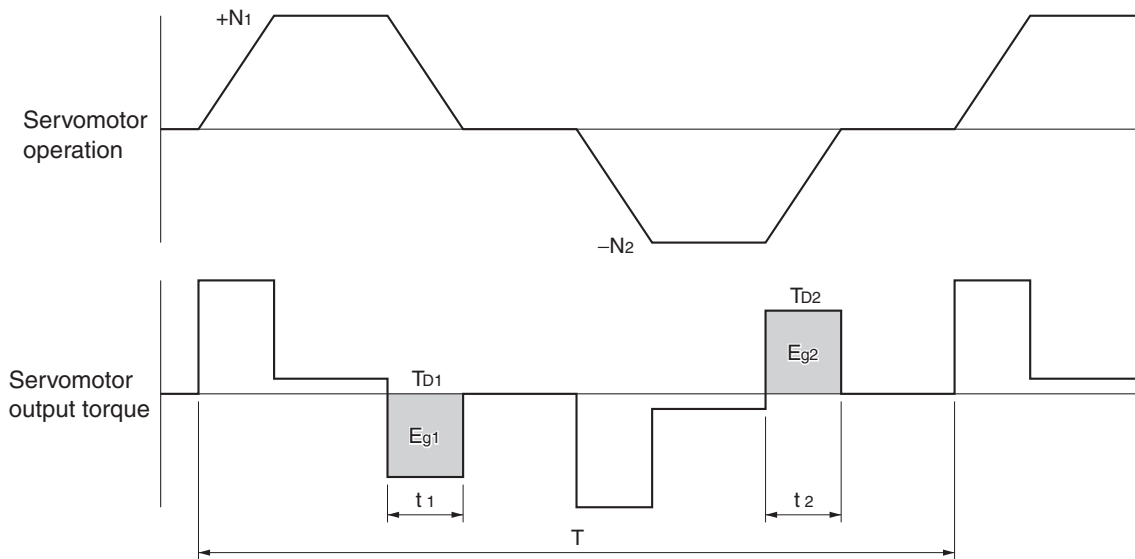

- In the output torque graph, acceleration in the positive direction is shown as positive, and acceleration in the negative direction is shown as negative.
- The regenerative energy values for each region can be derived from the following equations.

$$E_{g1} = \frac{1}{2} * \frac{2\pi}{60} * N_1 * T_{D1} * t_1 \text{ [J]}$$

$$E_{g2} = \frac{1}{2} * \frac{2\pi}{60} * N_2 * T_{D2} * t_2 \text{ [J]}$$

N<sub>1</sub>, N<sub>2</sub>: Rotation speed at beginning of deceleration [r/min]  
 T<sub>D1</sub>, T<sub>D2</sub>: Deceleration torque [N·m]  
 t<sub>1</sub>, t<sub>2</sub>: Deceleration time [s]

**Note** Due to the loss of winding resistance and PWM, the actual regenerative energy will be approximately 90% of the values derived from these equations.

- For Servo Drive models with internal capacitors used for absorbing regenerative energy (i.e., models of 400 W or less), the values for both  $E_{g1}$  or  $E_{g2}$  (unit: J) must be lower than the Servo Drive's regenerative energy absorption capacity. (The capacity depends on the model. For details, refer to *Servo Drive Regenerative Energy Absorption Capacity* on page 4-48.)
- For Servo Drive models with an internal regeneration resistor used for absorbing regenerative energy (i.e., models of 500 W or more), the average amount of regeneration  $P_r$  (unit: W) must be calculated, and this value must be lower than the Servo Drive's regenerative energy absorption capacity. (The capacity depends on the model. For details, refer to *Servo Drive Regenerative Energy Absorption Capacity* on page 4-48.)

The average regeneration power ( $P_r$ ) is the regeneration power produced in one cycle of operation.

$$P_r = (E_{g1} + E_{g2}) / T \text{ [W]}$$

T: Operation cycle [s]

## 4-4 Regenerative Energy Absorption

### Vertical Axis

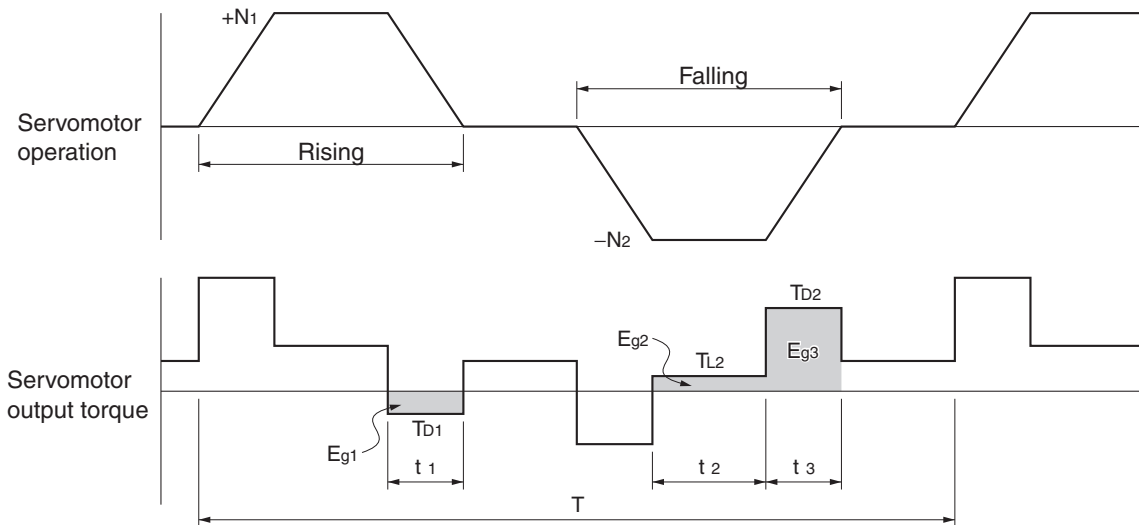

- In the output torque graph, acceleration in the positive direction (rising) is shown as positive, and acceleration in the negative direction (falling) is shown as negative.

- The regenerative energy values in each region can be derived from the following equations.

$$\cdot E_{g1} = \frac{1}{2} \cdot \frac{2\pi}{60} \cdot N_1 \cdot T_{D1} \cdot t_1 \quad [\text{J}]$$

$$\cdot E_{g2} = \frac{2\pi}{60} \cdot N_2 \cdot T_{L2} \cdot t_2 \quad [\text{J}]$$

$$\cdot E_{g3} = \frac{1}{2} \cdot \frac{2\pi}{60} \cdot N_2 \cdot T_{D2} \cdot t_3 \quad [\text{J}]$$

$N_1, N_2$ : Rotation speed at beginning of deceleration [r/min]

$T_{D1}, T_{D2}$ : Deceleration torque [N·m]

$T_{L2}$ : Torque when falling [N·m]

$t_1, t_3$ : Deceleration time [s]

$t_2$ : Constant-velocity travel time when falling [s]

**Note** Due to the loss of winding resistance, the actual regenerative energy will be approximately 90% of the values derived from these equations.

- For Servo Drive models with internal capacitors used for absorbing regenerative energy (i.e., models of 400 W or less.), the values for both  $E_{g1}$  or  $E_{g2} + E_{g3}$  (unit: J) must be lower than the Servo Drive's regenerative energy absorption capacity. (The capacity depends on the model. For details, refer to *Servo Drive Regenerative Energy Absorption Capacity* on page 4-48.)
- For Servo Drive models with an internal regeneration resistor used for absorbing regenerative energy (i.e., models of 500 W or more), the average amount of regeneration  $P_r$  (unit: W) must be calculated, and this value must be lower than the Servo Drive's regenerative energy absorption capacity. (The capacity depends on the model. For details, refer to *Servo Drive Regenerative Energy Absorption Capacity* on page 4-48.)

The average regeneration power ( $P_r$ ) is the regeneration power produced in one cycle of operation [W].

$$P_r = (E_{g1} + E_{g2} + E_{g3}) / T \quad [\text{W}]$$

T: Operation cycle [s]

## Servo Drive Regenerative Energy Absorption Capacity

### ■ Amount of Internal Regeneration Absorption in Servo Drives

The OMNUC G-Series Servo Drives absorb regenerative energy internally with built-in capacitors. If the regenerative energy is too large to be processed internally, an overvoltage error occurs and operation cannot continue. The following table shows the regenerative energy (and amount of regeneration) that each Servo Drive can absorb.

If these values are exceeded, take the following measures.

- Connect an External Regeneration Resistor (to improve the regeneration processing capacity).
- Reduce the operating rotation speed. (The amount of regeneration is proportional to the square of the rotation speed.)
- Lengthen the deceleration time (to decrease the regenerative energy produced per time unit).
- Lengthen the operation cycle, i.e., the cycle time (to decrease the average regeneration power).

Servo Drive	Regenerative energy (J) that can be absorbed by internal capacitor	Internal regeneration resistance		Minimum value of regeneration resistance ( $\Omega$ )
		Average amount of regeneration that can be absorbed (W)	Resistance ( $\Omega$ )	
R88D-GTA5L	12	---	---	18
R88D-GT01L	12	---	---	18
R88D-GT02L	18	---	---	18
R88D-GT04L	27	12	50	13
R88D-GT01H	16	---	---	35
R88D-GT02H	16	---	---	35
R88D-GT04H	25	---	---	35
R88D-GT08H	43	12	100	27
R88D-GT10H	70	20	30	27
R88D-GT15H	70	20	30	18
R88D-GT20H	70	40	15	11
R88D-GT30H	70	40	15	11
R88D-GT50H	105	80	10	7
R88D-GT75H	250	---	---	4

**Note** These are the values at 100 VAC for 100-VAC models, and at 200 VAC for 200-VAC models.

### Absorbing Regenerative Energy with an External Regeneration Resistor

If the regenerative energy exceeds the absorption capacity of the Servo Drive, connect an External Regeneration Resistor. Connect the External Regeneration Resistor between B1 and B2 terminals on the Servo Drive. Double-check the terminal names when connecting the resistor because the Servo Drive may be damaged by burning if connected to the wrong terminals. The External Regeneration Resistor will heat up to approximately 120°C. Do not place it near equipment and wiring that is easily affected by heat. Attach radiator plates suitable for the heat radiation conditions.

#### External Regeneration Resistor

##### Performance Specifications

Model	Resistance	Nominal capacity	Regeneration absorption at 120°C	Heat radiation condition	Thermal switch output specifications
R88A-RR08050S	50 Ω	80 W	20 W	Aluminum, 350 × 350, Thickness: 3.0	Operating temperature: 150°C ±5% NC contact Rated output: 30 VDC, 50 mA max. (minimum current: 1 mA)
R88A-RR080100S	100 Ω	80 W	20 W	Aluminum, 350 × 350, Thickness: 3.0	Operating temperature: 150°C ±5% NC contact Rated output: 30 VDC, 50 mA max. (minimum current: 1 mA)
R88A-RR22047S1	47 Ω	220 W	70 W	Aluminum, 350 × 350, Thickness: 3.0	Operating temperature: 150°C ± 5°C NC contact Rated output (resistive load): 250 VAC, 0.2 A max. 42 VDC, 0.2 A max. (minimum current: 1 mA)
R88A-RR50020S	20 Ω	500 W	180 W	Aluminum, 600 × 600, Thickness: 3.0	Operating temperature: 200°C ±7°C NC contact Rated output: 250 VAC, 0.2 A max. 24 VDC, 0.2 A max. (minimum current: 1 mA)

### Connecting an External Regeneration Resistor

#### R88D-GTA5L/-GT01L/-GT02L/-GT01H/-GT02H/-GT04H

If an External Regeneration Resistor is necessary, connect it between B1 and B2 as shown in the diagram below.

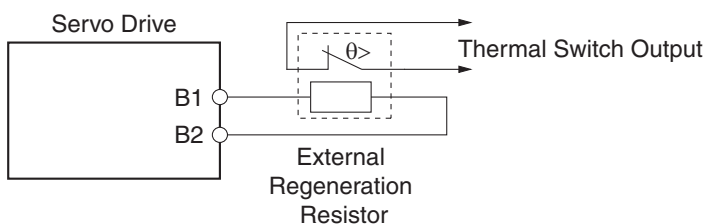

**Precautions for Correct Use**

- ◆ Connect the thermal switch output so that the main circuit power supply is shut OFF when the contacts open. The resistor may be damaged by burning, or cause fire if it is used without setting up a power supply shutoff sequence using the output from the thermal switch.

■ R88D-GT04L/-GT08H/-GT10H/-GT15H/-GT20H/-GT30H/-GT50H

If an External Regeneration Resistor is necessary, remove the short-circuit bar between B2 and B3, and then connect the External Regeneration Resistor between B1 and B2 as shown in the diagram below.

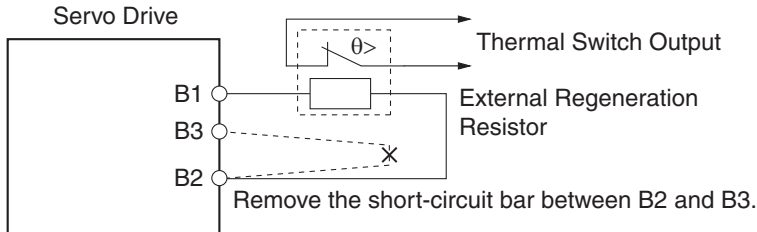

**Precautions for Correct Use**

- ◆ Connect the thermal switch output so that the main circuit power supply is shut OFF when the contacts open. When using multiple External Regeneration Resistors, connect each thermal switch in series. The resistor may be damaged by burning, or cause fire if it is used without setting up a power supply shutoff sequence using the output from the thermal switch.

■ R88D-GT75H

If an External Regeneration Resistor is necessary, connect it between B1 and B2 as shown in the diagram below.

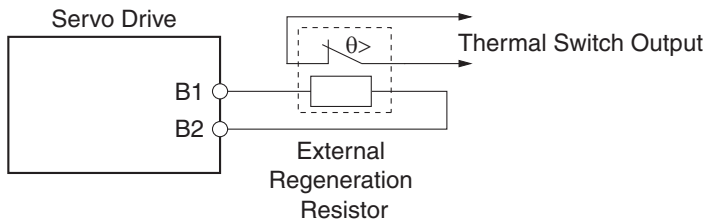



**Precautions for Correct Use**

- ◆ Connect the thermal switch output so that the main circuit power supply is shut OFF when the contacts open. When using multiple External Regeneration Resistors, connect each thermal switch in series. The resistor may be damaged by burning, or cause fire if it is used without setting up a power supply shutoff sequence using the output from the thermal switch.

## 4-4 Regenerative Energy Absorption

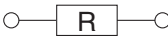
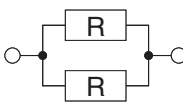
### Combining External Regeneration Resistors

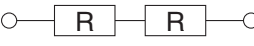
Regeneration absorption capacity <sup>*1</sup>	20 W	40 W	70 W	140 W
Model	R88A-RR08050S R88A-RR080100S	R88A-RR08050S R88A-RR080100S	R88A-RR22047S1	R88A-RR22047S1
Resistance <sup>*2</sup>	50 Ω/100 Ω	25 Ω/50 Ω	47 Ω	94 Ω
Connection method				

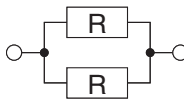
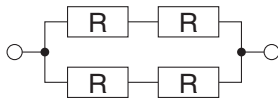
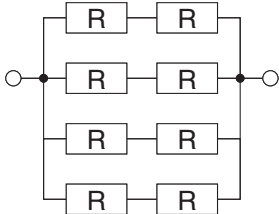
Regeneration absorption capacity <sup>*1</sup>	140 W	280 W	560 W
Model	R88A-RR22047S1	R88A-RR22047S1	R88A-RR22047S1
Resistance <sup>*2</sup>	23.5 Ω	47 Ω	23.5 Ω
Connection method			

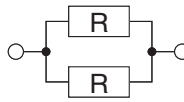
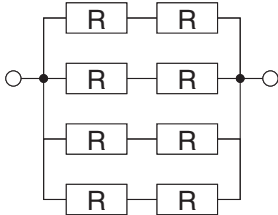
Regeneration absorption capacity <sup>*1</sup>	180 W	360 W	1440 W
Model	R88A-RR50020S	R88A-RR50020S	R88A-RR50020S
Resistance <sup>*2</sup>	20 Ω	10 Ω	10 Ω
Connection method			

\*1. Select a combination that has an absorption capacity greater than the average regeneration power ( $P_r$ ).

\*2. Do not use a combination with resistance values lower than the minimum value of regeneration resistance of each Servo Drive. For information on the minimum value of regeneration resistance, refer to *Servo Drive Regenerative Energy Absorption Capacity* on page 4-48.

#### Precautions for Correct Use

- ◆ Surface temperatures on regeneration resistors can reach 200°C. Do not place objects that tend to catch fire near the resistors. To prevent people from touching them, install a type of cover that enables heat dissipation.



# Chapter 5

## Operating Functions

5-1	Position Control .....	5-1
5-2	Speed Control .....	5-3
5-3	Internally Set Speed Control .....	5-5
5-4	Torque Control .....	5-8
5-5	Switching the Control Mode .....	5-11
5-6	Forward and Reverse Drive Prohibit .....	5-14
5-7	Encoder Dividing .....	5-15
5-8	Electronic Gear .....	5-16
5-9	Overrun Limit.....	5-19
5-10	Brake Interlock .....	5-21
5-11	Gain Switching .....	5-25
5-12	Torque Limit .....	5-26
5-13	Soft Start .....	5-28
5-14	Position Command Filter .....	5-29
5-15	Speed Limit .....	5-30
5-16	User Parameters .....	5-31
	Setting and Checking Parameters .....	5-31
	Parameter Tables .....	5-33
	Parameters Details .....	5-51

# 5-1 Position Control

## Function

- Perform control using the pulse-string input from CN1 pins 3 to 6.
- The Servomotor rotates using the value of the pulse-string input multiplied by the Electronic Gear Ratio (Pn48 to Pn4B).

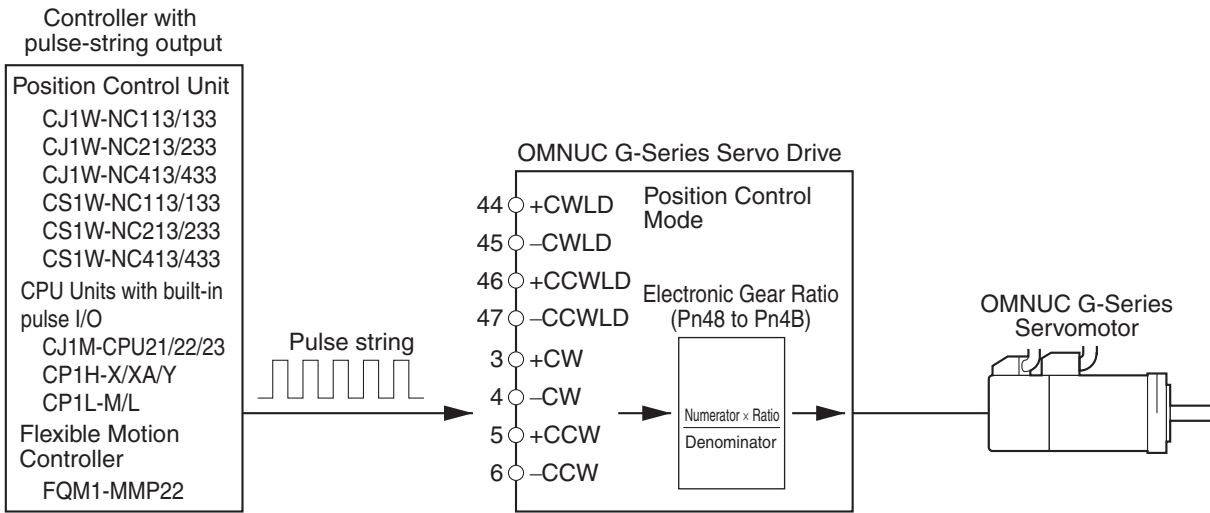

## Parameters Requiring Settings

Parameter No.	Parameter name	Explanation	Reference page
Pn02	Control Mode Selection	Select the control mode for position control (setting: 0, 3, or 4).	5-53
Pn40	Command Pulse Input Selection	Select using a photocoupler input or a line-driver input as the command pulse input.	5-74
Pn41	Command Pulse Rotation Direction Switch	Set to match the command pulse form of the controller.	5-74
Pn42	Command Pulse Mode		5-75
Pn48 to Pn4B	Electronic Gear Ratio	Set the pulse rate for command pulses and Servomotor travel amount.	5-78

## Related Functions

- The main functions related to position control are as follows:

Function	Explanation	Reference page
Position command filter function	Sets the soft start for the command pulse.	5-29
Feed-forward function	Adds the command pulse differential to the speed loop to reduce the positioning time.	5-61
Torque limit function	Limits the Servomotor's torque output.	5-26

## Parameter Block Diagram for Position Control Mode

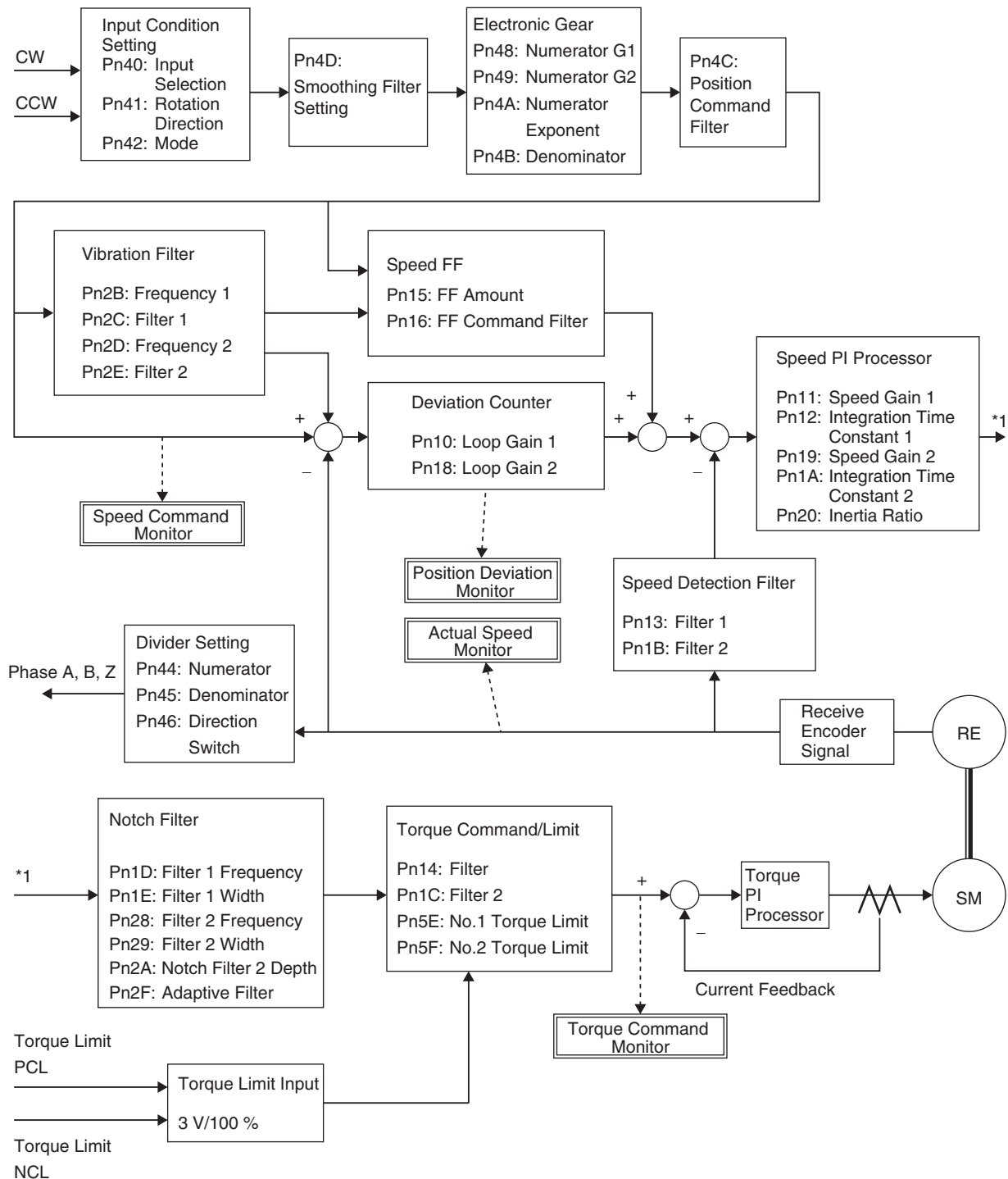

# 5-2 Speed Control

## Function

- Performs Servomotor speed control using analog voltage input from the speed command (REF: CN1 pins 14 and 15). You can also perform speed control by combining with a controller that has a position control function.
- You can change the relation between the speed command and the rotation speed by setting the Speed Command Scale (Pn50).

5  
Operating Functions

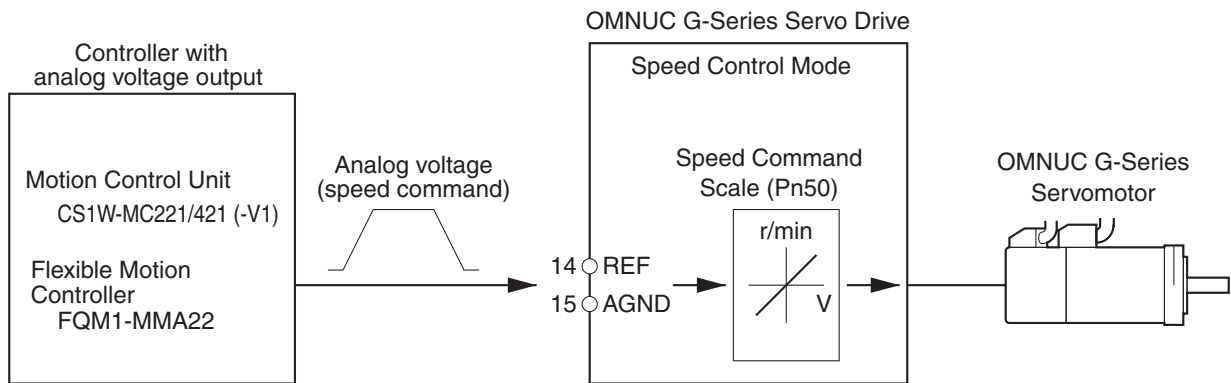

## Parameters Requiring Settings

Parameter No.	Parameter name	Explanation	Reference page
Pn02	Control Mode Selection	Set the control mode for speed control (Settings: 1, 3, 5)	5-53
Pn50	Speed Command Scale	<p>Set the REF (speed command input) voltage for operating at the rated rotation speed.</p>	5-81

### Related Functions

- The main functions related to speed control are as follows:

Function	Explanation	Reference page
Soft start function	Sets the soft start for the speed command.	5-28
Torque limit function	Limits the Servomotor's torque output.	5-26

### Parameter Block Diagram for Speed Control Mode

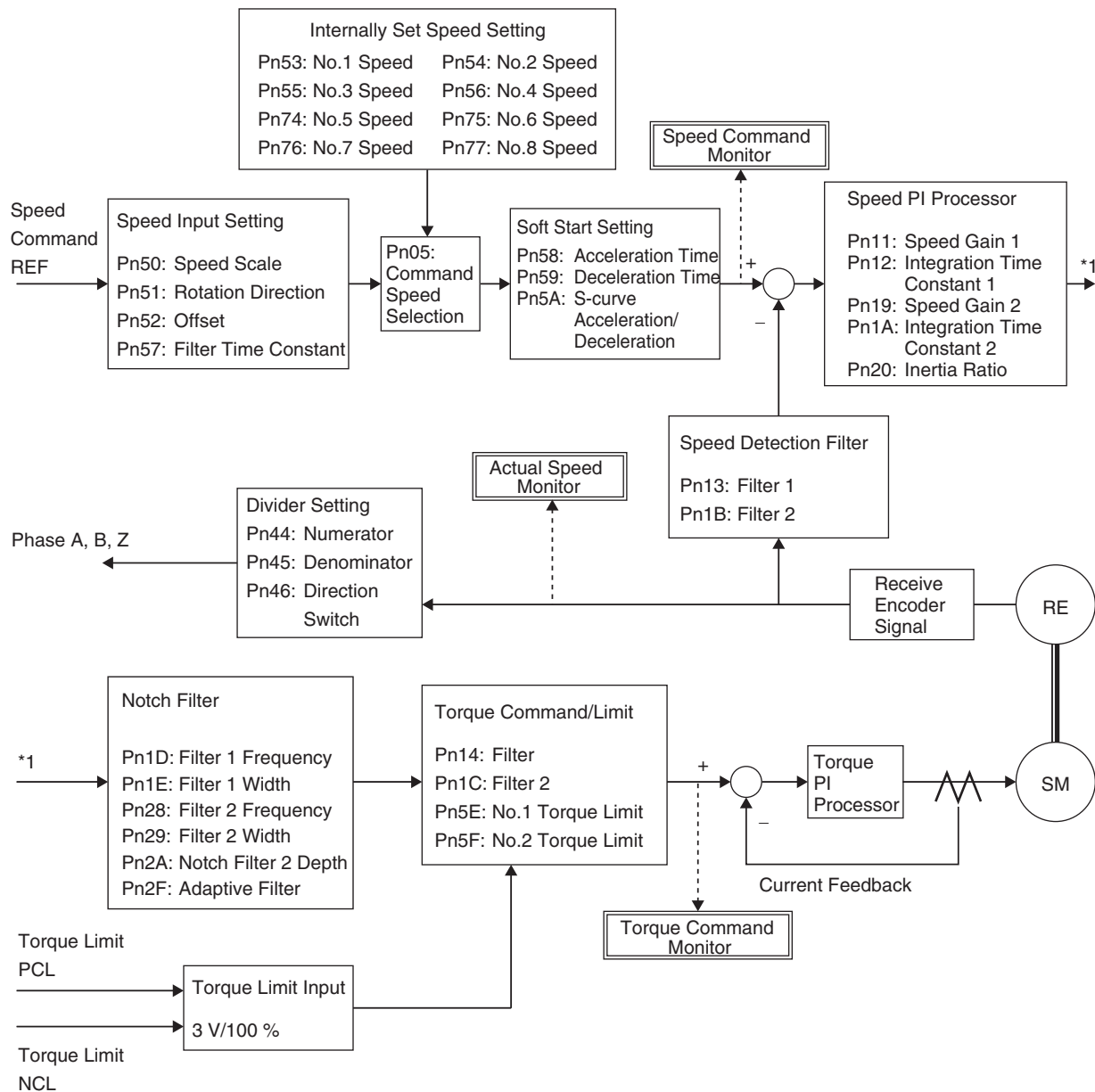

# 5-3 Internally Set Speed Control

## Function

- Performs Servomotor speed control using the speeds set in the No. 1 to 8 Internally Set Speeds.
- Select the internally set speed using the Internally Set Speed Selection 1 to 3 of the control input terminals (VSEL1: CN1 pin 33, VSEL2: CN1 pin 30, VSEL3: CN1 pin 28).

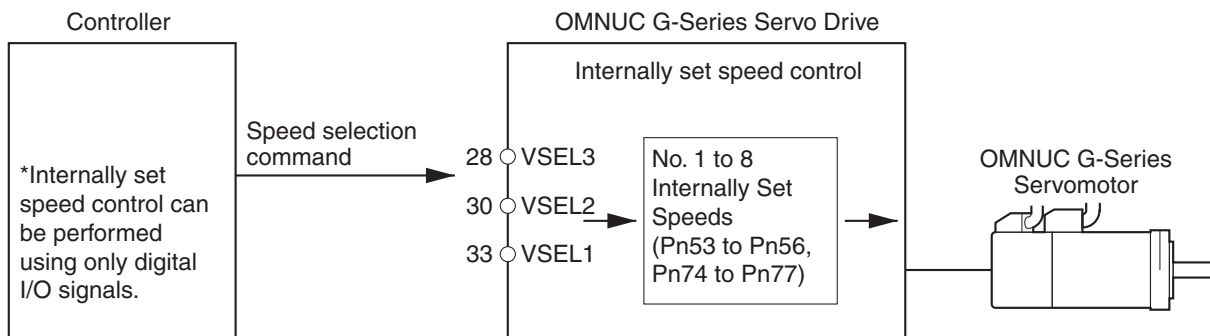

## Parameters Requiring Settings

Parameter No.	Parameter name	Explanation	Reference page
Pn02	Control Mode Selection	Select the control mode for internally set speeds (setting: 1, 3, or 5).	5-53
Pn05	Command Speed Selection	Make a setting to use the internally set speeds (setting: 1, 2, or 3).	5-54
Pn53	No. 1 Internally Set Speed	Set the internally set speeds (r/min). The settings can be made from -20,000 to 20,000 r/min. Be sure to set the speeds within the allowable range of rotation speed of the Servomotor.	5-82
Pn54	No. 2 Internally Set Speed		
Pn55	No. 3 Internally Set Speed		
Pn56	No. 4 Internally Set Speed		
Pn74	No. 5 Internally Set Speed		
Pn75	No. 6 Internally Set Speed		
Pn76	No. 7 Internally Set Speed		
Pn77	No. 8 Internally Set Speed		
Pn58	Soft Start Acceleration Time	Set the acceleration time for internally set speed control. Set the time (setting × 2 ms) until 1,000 r/min is reached.	5-83
Pn59	Soft Start Deceleration Time	Set the deceleration time for internally set speed control. Set the time (setting × 2 ms) until 1,000 r/min is reached.	5-83
Pn5A	S-curve Acceleration/Deceleration Time Setting	Set the S-curve time width (setting × 2 ms) centered on the inflection points for acceleration and deceleration.	5-83

### ■ Selecting the Internally Set Speeds

The following tables show the internally set speeds that are set with VSEL1, VSEL2, and VSEL3 (Internally Set Speed Selection 1, 2, and 3 Inputs).

**Pn05 = 1**

No.	VSEL1	VSEL2	VSEL3	Set speed
0	OFF	OFF	OFF	Pn53
1	ON	OFF	OFF	Pn54
2	OFF	ON	OFF	Pn55
3	ON	ON	OFF	Pn56
4	OFF	OFF	ON	Pn53
5	ON	OFF	ON	Pn54
6	OFF	ON	ON	Pn55
7	ON	ON	ON	Pn56

**Pn05 = 2**

No.	VSEL1	VSEL2	VSEL3	Set speed
0	OFF	OFF	OFF	Pn53
1	ON	OFF	OFF	Pn54
2	OFF	ON	OFF	Pn55
3	ON	ON	OFF	*1
4	OFF	OFF	ON	Pn53
5	ON	OFF	ON	Pn54
6	OFF	ON	ON	Pn55
7	ON	ON	ON	*1

\*1. The mode will be analog speed control.  
Input the proper current to REF.

**Pn05 = 3**

No.	VSEL1	VSEL2	VSEL3	Set speed
0	OFF	OFF	OFF	Pn53
1	ON	OFF	OFF	Pn54
2	OFF	ON	OFF	Pn55
3	ON	ON	OFF	Pn56
4	OFF	OFF	ON	Pn74
5	ON	OFF	ON	Pn75
6	OFF	ON	ON	Pn76
7	ON	ON	ON	Pn77

**■ Operation Example**

- Internally Set Speed Control with Four Speed Changes When Pn05 = 1

## 5-3 Internally Set Speed Control

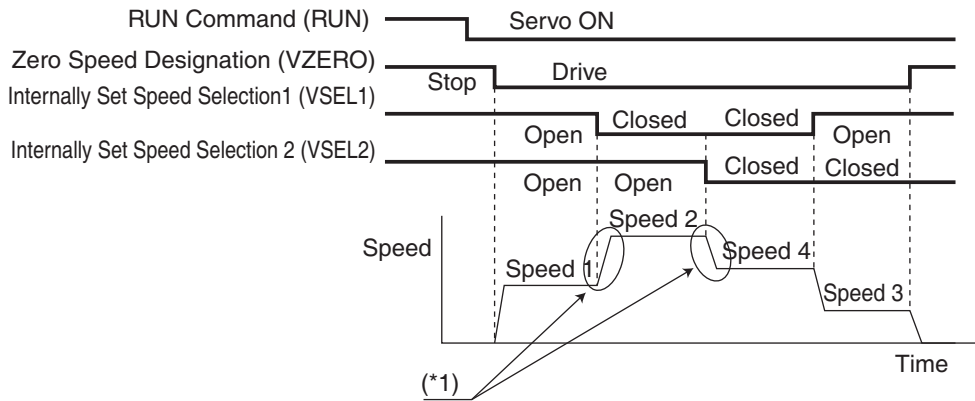

\*1. The acceleration time, deceleration time, and S-curve acceleration/deceleration time can be set using parameters (Pn58, Pn59, and Pn5A).

**Note** If more than one internally set speed selection signal is switched at the same time (e.g., as when switching from Speed 2 to Speed 3), an internally set speed signal in the process of switching may be temporarily selected. (For example, Speed 1 or Speed 4 may be temporarily selected.)

The internally set speed command may be temporarily performed with a sudden change, especially if the acceleration or deceleration time is set to 0 or small value, or if the speed difference between internally set speed commands is large. Use this function with the following precautions.

- Avoid switching more than one internally set speed selection signal at the same time.
- Set both Soft Start Acceleration Time and Soft Start Deceleration Time so that the speed changes gradually and avoid a sudden change.



## 5-4 Torque Control

### Function

- Controls the Servomotor output torque using analog voltage input from the torque command (TREF: CN1 pins 14 to 17).
- You can change the relation between the torque command and output torque using the Torque Command Scale (Pn5C) setting.
- The setting procedure depends on the control mode.

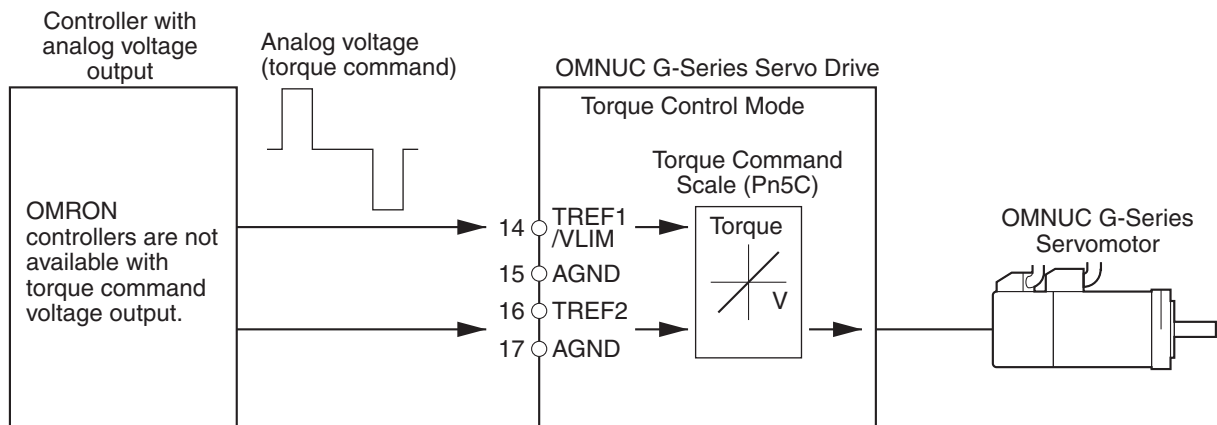

### Parameters Requiring Settings

#### Pn02 = 2 or 4 (Torque Control, Torque/Position Switch Control)

	Pn5B = 0	Pn5B = 1
TREF1/ VLIM pin 14	Torque command input. Set the gain, polarity, offset, and filter for the torque command by using Pn5C, Pn5D, Pn52, and Pn57.	Analog speed limit input. To set the gain, offset, and filter for the speed limit, use Pn50, Pn52, and Pn57, respectively.
TREF2 pin 16	This input is disabled. The speed limit will be the No. 4 Internally Set Speed (Pn56).	Torque command input. Set the gain and polarity for the torque command by using Pn5C and Pn5D. Offsets and filters cannot be used.

**Note** Servomotor rotation speed in torque control varies according to the Servomotor load conditions (e.g., friction, external power, inertia). Take safety measures on the machine device side to prevent Servomotor runaway.

Parameter No.	Parameter name (function)	Explanation	Reference page
Pn52	Speed Command Offset Adjustment	The speed command input will be offset by approximately the set value times 0.3 mV.	5-81
Pn57	Speed Command Filter Time Constant	Set the time constant for the first-order lag filter.	5-82
Pn5C	Torque Command Scale	<p>Set the TREF (torque command input) voltage to output the rated torque.</p> <p>Output torque (rated torque ratio)</p> <p>Command input voltage</p>	5-84
Pn5D	Torque Output Direction Switch	Reverse the polarity of the torque command input.	5-84

**Pn02 = 5 (Torque/Speed Switch Control)**

	Pn5B = 0	Pn5B = 1
TREF1/ VLIM pin 14	This input is disabled. The speed limit will be the No. 4 Internally Set Speed (Pn56).	Analog speed limit input. To set the gain, offset, and filter for the speed limit, use Pn50, Pn52, and Pn57, respectively.
TREF2 pin 16	Torque command input. The gain, polarity, offset, and filter for the torque command can be set using Pn5C and Pn5D. Offsets and filters cannot be used.	

**Related Functions**

Functions related to torque control are as follows:

Function	Explanation	Reference page
Torque limit function	This function limits the Servomotor's torque output.	5-26
Speed limit function	This function controls the Servomotor rotation speed so that it does not become too high.	5-30

### Parameter Block Diagram for Torque Control Mode

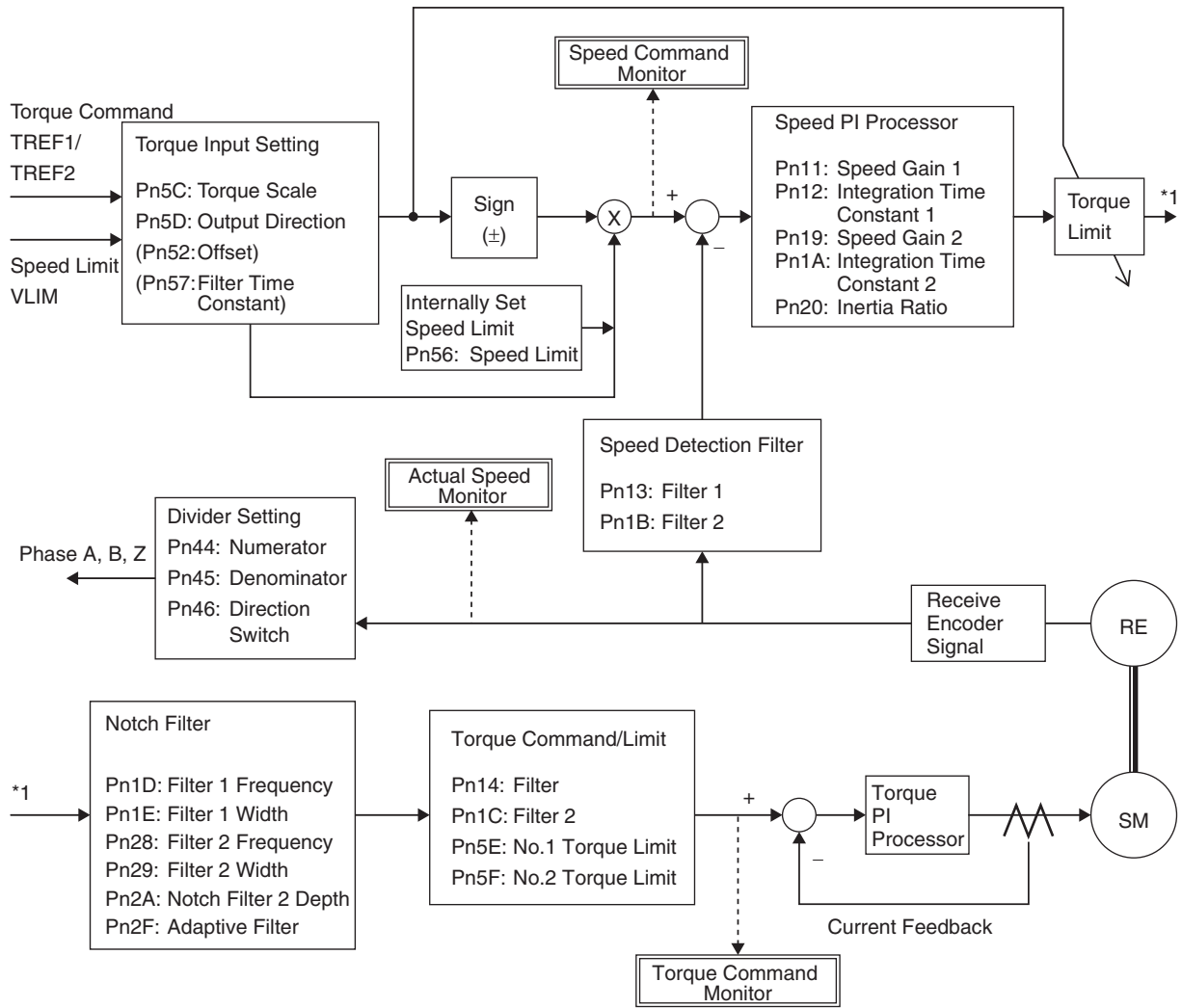

# 5-5 Switching the Control Mode

## Function

- This function controls the Servomotor by switching between two control modes via external inputs.
- The control mode switching is performed at the Control Mode Switch Input (TVSEL: CN1 pin 32).

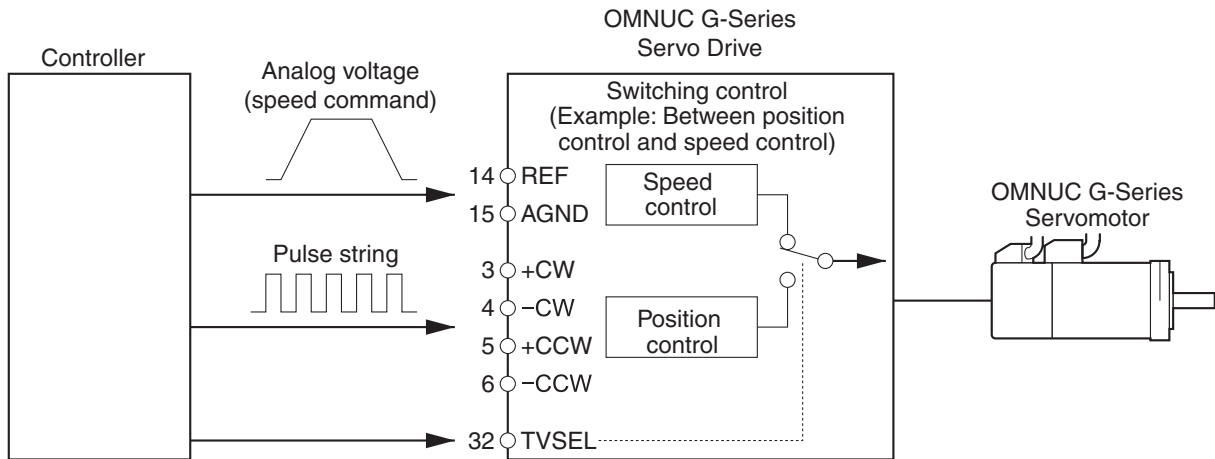

## Parameters Requiring Settings

Parameter No.	Parameter name	Explanation	Reference page
Pn02	Control Mode Selection	Select control mode for switching control (Settings: 3, 4, 5)	5-53

### ■ Control Mode Selected at TVSEL (Control Mode Switch Input)

- The following table shows the relation between TVSEL (Control Mode Switch Input) and the control mode selected.

Control Mode Selection (Pn02) setting	TVSEL	
	OFF	ON
3	Position control	Speed control
4	Position control	Position control
5	Speed control	Torque control

**Note** Use caution when switching control modes. Operation may change suddenly depending on the control mode settings.

## ■ Operation Examples

### Position and Speed Control Switching Example (Pn02 = 3)

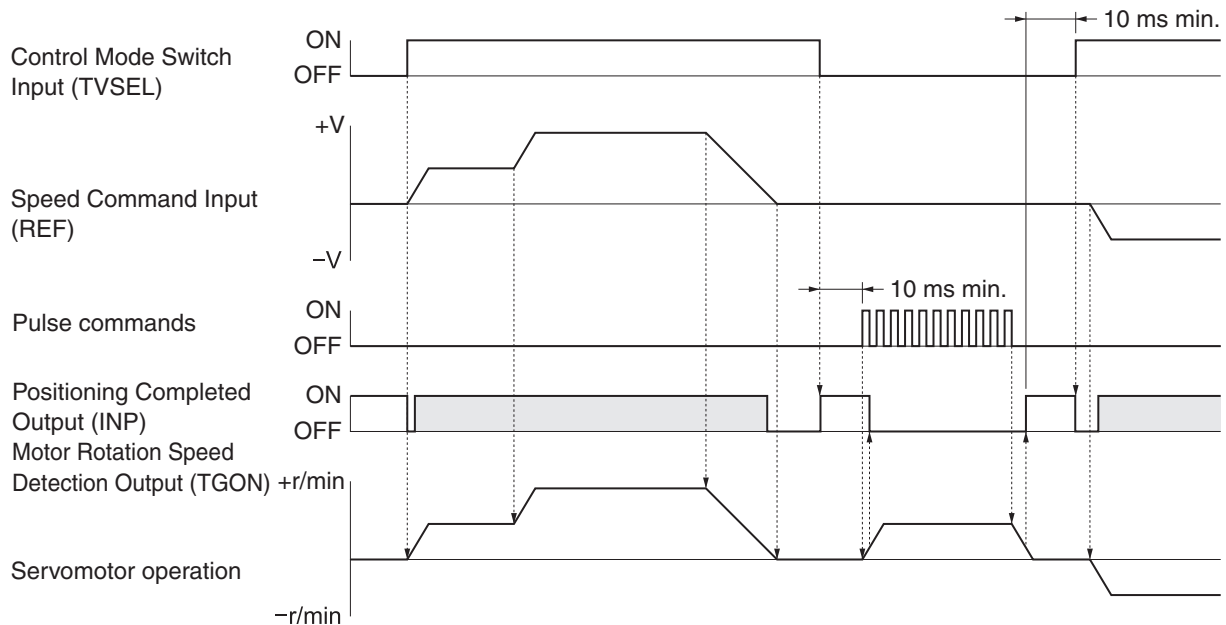

- There is a maximum delay of 10 ms in reading the input signal.
- When switching from speed control to position control, turn OFF the Control Mode Switch Input (TVSEL) and wait at least 10 ms after the Positioning Completed Output (INP) turns ON before inputting the pulse command. The pulses input before INP turns ON will be ignored.
- The shaded areas for the Positioning Completed Output (INP) in the time chart show that the signal is turned ON as the Servomotor Rotation Detection Output (TGON). (The meaning of the signal depends on the control mode.)

### Position and Torque Control Switching Example (Pn02 = 4)

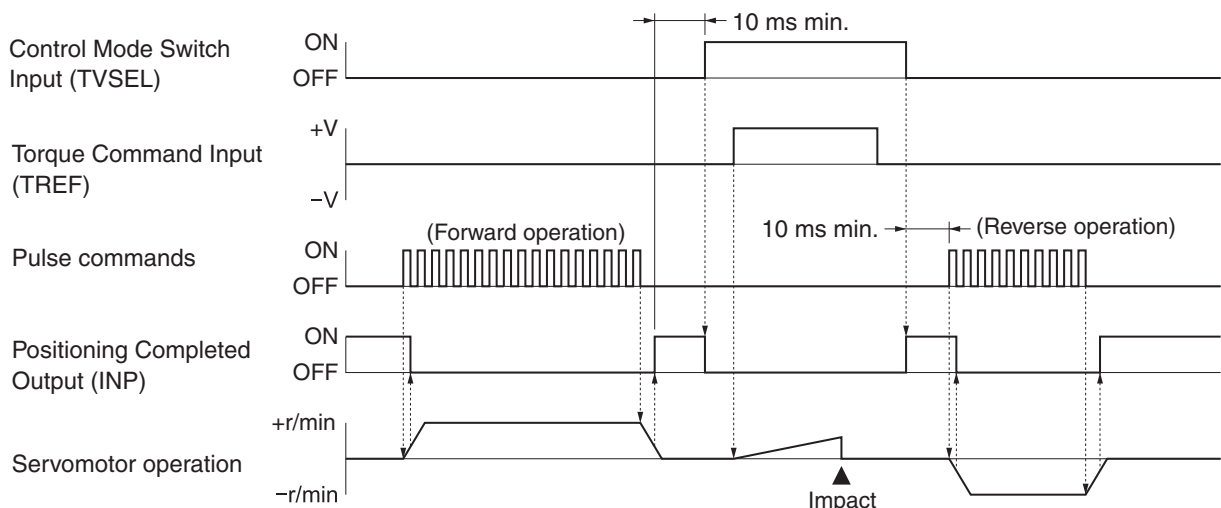

- This time chart shows an example of torque thrust.
- There is a maximum delay of 10 ms in reading the input signal.
- When switching from torque control to position control, turn OFF the Control Mode Switch Input (TVSEL) and wait at least 10 ms after the Positioning Completed Output (INP) turns ON before inputting the pulse command. The pulses input before INP turns ON will be ignored.

## 5-5 Switching the Control Mode

### Speed and Torque Control Switching Example (Pn02 = 5)

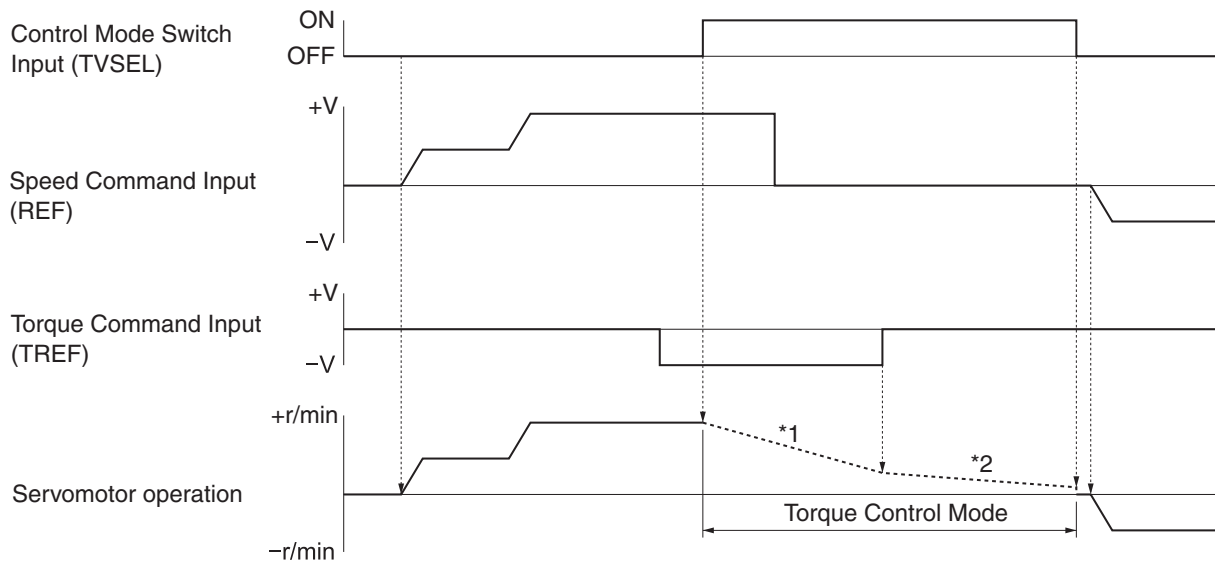

\*1. Deceleration for the torque command.

\*2. Deceleration due to load inertia energy and load friction torque.

- There is a maximum delay of 10 ms in reading the input signal.
- Servomotor operation in Torque Control Mode changes according to the Servomotor load conditions (e.g., friction, external power, inertia). Take safety measures on the machine side to prevent Servomotor runaway.

### Related Functions

Refer to the related functions for each control mode.

# 5-6 Forward and Reverse Drive Prohibit

## Function

- When the Forward Drive Prohibit Input (POT: CN1 pin 9) and Reverse Drive Prohibit Input (NOT: CN1 pin 8) are turned OFF, the Servomotor will stop rotating.
- You can stop the Servomotor from rotating beyond the device's operating range by connecting limit inputs.

## Parameters Requiring Settings

Parameter No.	Parameter name	Explanation	Reference page
Pn04	Drive Prohibit Input Selection	Enable or disable the Forward/Reverse Drive Prohibit Inputs.	5-54
Pn66	Stop Selection for Drive Prohibition Input	Set the operation for decelerating to a stop after the Forward/Reverse Drive Prohibit Input turns OFF. Set whether to use the dynamic brake to stop or free-running.	5-88

## Operation

Stopping Methods When Forward/Reverse Drive Prohibit Is OFF

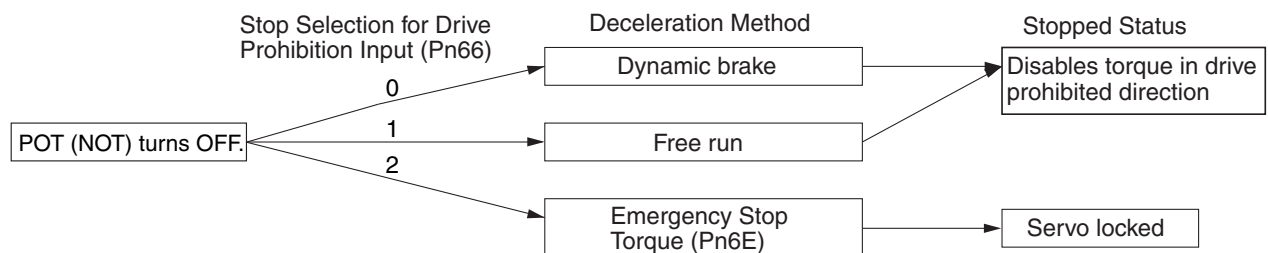

While the Forward Drive Prohibit Input (POT) is OFF, the Servomotor cannot be driven in the forward direction, but it can be driven in the reverse direction. Conversely, while the Reverse Drive Prohibit Input (NOT) is OFF, the Servomotor cannot be driven in the reverse direction, but it can be driven in the forward direction.

With a vertical axis, there is a risk that the load may drop when drive is prohibited by the drive prohibit input. To prevent this, it is recommended that the deceleration method be set to use emergency stop torque in the Drive Prohibit Input Stop Selection parameter (Pn066), and that stopping in the servo-lock state be set (set value: 2).

# 5-7 Encoder Dividing

## Function

- The number of pulses can be set for the encoder signals output from the Servo Drive.

## Parameters Requiring Settings

Parameter No.	Parameter name	Explanation	Reference page
Pn44	Encoder Divider Numerator Setting	Set the number of pulses to be output in combination with the Encoder Divider Denominator Setting (Pn45).	5-76
Pn45	Encoder Divider Denominator Setting	Set the number of pulses to be output in combination with the Encoder Divider Numerator Setting (Pn44).	5-76
Pn46	Encoder Output Direction Switch	Set the phase-B logic and output source for the pulse output (CN1 -B: pin 48, CN1 +B: pin 49)	5-77

## Operation

- Incremental pulses are output from the Servo Drive through a frequency divider.

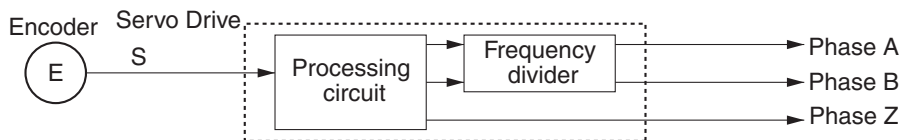

- The output phases of the encoder signal output from the Servo Drive are as shown below.

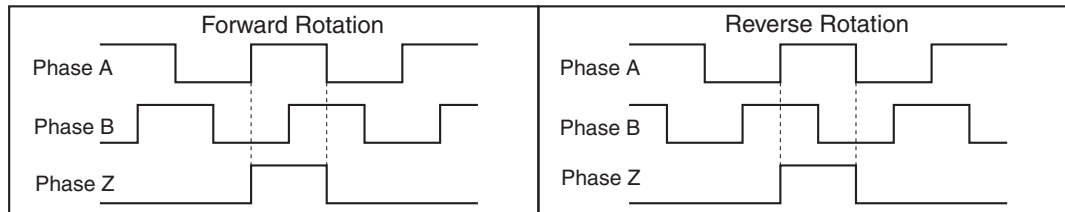



# 5-8 Electronic Gear

## Function

- The Servomotor can be rotated for the number of pulses obtained by multiplying the command pulses by the electronic gear ratio.
- This function is effective under the following conditions:
  - When fine-tuning the position and speed of two lines that are to be synchronous.
  - When using a position controller with a low command pulse frequency.
  - When you want to set the machine travel distance per pulse, to 0.01 mm for example.

## Parameters Requiring Settings

Parameter No.	Parameter name	Explanation	Reference page
Pn48	Electronic Gear Ratio Numerator 1 *1	Set the pulse rate for command pulses and Servomotor travel distance.  Electronic Gear Ratio Numerator 1 (Pn48) or $\times 2$ Electronic Gear Ratio Numerator Exponent (Pn4A) Electronic Gear Ratio Numerator 2 (Pn49) ----- Electronic Gear Ratio Denominator (Pn4B)	5-78
Pn49	Electronic Gear Ratio Numerator 2 *1		
Pn4A	Electronic Gear Ratio Numerator Exponent		
Pn4B	Electronic Gear Ratio Denominator	<p>The upper limit of the gear ratio numerator is determined by the following formulas.</p> <ul style="list-style-type: none"> <li>• Electronic Gear Ratio Numerator 1 <math>Pn48 \times 2^{Pn4A} \leq 4,194,304/(Pn4D+1)</math></li> <li>• Electronic Gear Ratio Numerator 2 <math>Pn49 \times 2^{Pn4A} \leq 4,194,304/(Pn4D+1)</math></li> </ul> <p>Pn48: Electronic Gear Ratio Numerator 1 Pn49: Electronic Gear Ratio Numerator 2 Pn4A: Electronic Gear Ratio Numerator Exponent Pn4D: Smoothing Filter Setting</p> <p>Any higher setting will be invalid, and the numerator will be <math>4,194,304/(Pn4D+1)</math>. If the numerator is 0, the encoder resolution will be automatically set to the value of the numerator and the number of command pulses per rotation can be set in Pn4B.</p>	

\*1. The Electronic Gear Switch Input (GESEL) is used to switch between Electronic Gear Ratio Numerator 1 (Pn48) and Electronic Gear Ratio Numerator 2 (Pn49).

## Operation

### Calculation Method

- The following equation shows the relation between the number of internal command pulses (F) multiplied by the electronic gear ratio and the number of command pulses (f) per Servomotor

rotation.

$$F = f \times \frac{Pn48 \times 2^{Pn4A}}{Pn4B}$$

- When an encoder with a resolution of 2,500 pulses/rotation is used, the number of internal command pulses (F) in the Servo Drive will be 10,000 pulses/rotation (2,500 pulses/rotation × 4).
- Given the conditions above, the relation between the number of command pulses per Servomotor rotation (f) and the electronic gear ratio is as follows:

$$\frac{F}{f} = \frac{10000}{f} = \frac{Pn48 \times 2^{Pn4A}}{Pn4B}$$

### Calculation Examples (For a 2,500 pulses/rotation encoder)

- Make the following settings to operate with 2,000 pulses/rotation.

$$\frac{10000 (Pn48) \times 2^0 (Pn4A)}{2000 (Pn4B)}$$

- Similarly, make the following settings to operate with 1,000 pulses/rotation.

$$\frac{10000 (Pn48) \times 2^0 (Pn4A)}{1000 (Pn4B)}$$

- Conversely, make the following settings to increase the resolution per rotation and operate with 40,000 pulses/rotation.

$$\frac{10000}{40000} = \frac{2500 (Pn48) \times 2^0 (Pn4A)}{10000 (Pn4B)}$$

The setting ranges for Pn48, Pn49, and Pn4B are from 1 to 10,000, so reduction is required in the settings.

### Calculation Example (For a 17-bit encoder)

- Use the following setting to operate at 5,000 pulses/rotation:

$$\frac{1 (Pn48) \times 2^{17} (Pn4A)}{5000 (Pn4B)}$$

Set the parameters so that the command pulse frequency multiplied by the electronic gear ratio does not exceed 80 Mpps. If 80 Mpps is exceeded, alarm 27 will occur.

Example:

The following calculation is for an absolute encoder with a resolution of 131,072, an electronic gear setting of 500 (Pn48 = 1 , Pn49 = 1 , Pn4A = 17 , Pn4B = 500 ), and a command pulse frequency of 500 kpps.

500 kpps × 131,072/500 = 131,072,000 = 131.072 Mpps, which exceeds 80 Mpps.

The calculation changes as follows if the electronic gear is set to 5,000 (Pn48 = 1 , Pn49 = 1 , Pn4A = 17 , Pn4B = 5,000) and the command pulse frequency is 500 kpps.

500 kpps × 131,072/5,000 = 13,107,200 = 13.1072 Mpps, which does not exceed 80 Mpps.

---

## Related Parameter

The main function provided by the parameter related to the electronic gear is given in the following table.

Parameter No.	Parameter name	Explanation	Reference page
Pn40	Command Pulse Input Selection	The command pulses are multiplied by a factor of 2 or 4 when using 90° phase difference signal inputs is selected as the input format for the command pulse in the Command Pulse Mode (Pn42).	5-74

## 5-9 Overrun Limit

### Function

- The Servomotor can be stopped with an alarm for an overrun limit error (alarm code 34) if the Servomotor exceeds the allowable operating range set in the Overrun Limit Setting (Pn26) with respect to the position command input.
- This can be used to prevent impact on the edges of the machine because of Servomotor oscillation.

### Parameters Requiring Settings

Parameter No.	Parameter name	Explanation	Reference page
Pn26	Overrun Limit Setting	Set the Servomotor's allowable operating range for the position command input range. An overrun limit error (alarm code 34) will occur if the set value is exceeded.	5-65

### Operating Conditions

- The overrun limit will operate under the following conditions.

	Conditions under which the overrun limit will operate
Operating mode	Position Control Mode is used. Pn02 = 0: Position control Pn02 = 3: First control mode for position/speed control Pn02 = 4: First control mode for position/torque control
Others	<ul style="list-style-type: none"> <li>♦ 1. The servo is ON.</li> <li>♦ 2. The Overrun Limit Setting (Pn26) is not 0.</li> <li>♦ 3. The allowable operating range for both forward and reverse is within 2147483647 after the position command input range is cleared to zero.</li> </ul> If the condition 1 above is not met, the Overrun Limit Setting will be disabled until the conditions for clearing the position command input range are satisfied, as described below. If the conditions 1 and 2 above are not met, the position command input range will be cleared to zero.

#### Conditions for Clearing the Position Command Input Range

The position command input range will be cleared to zero under the following conditions.

- The power supply is turned ON.
- The position deviation is cleared. (The deviation counter clearing is enabled and drive prohibit input is enabled by setting the Stop Selection for Drive Prohibition Input (Pn66) to 2.)
- Normal Mode Autotuning starts or ends.

## Operating Examples

### ■ No Position Command Input (Servo ON)

No position command is input, and so the Servomotor's allowable operating range for both sides will be the range of the travel distance set in Pn26. An overrun limit error will occur if the load enters the range for generating alarm code 34 (range of slanted lines) due to oscillation.

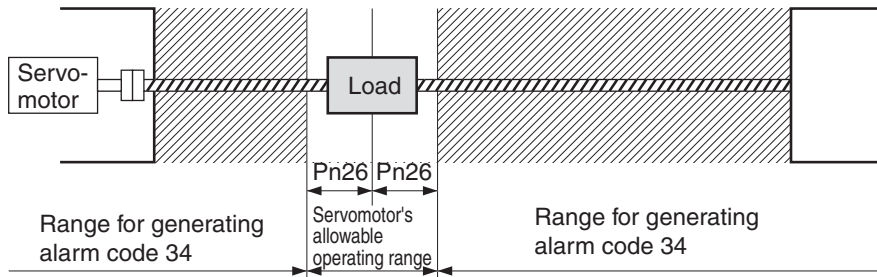

### ■ Right Side Operation (Servo ON)

When the position command to the right is input, the Servomotor's allowable operating range will increase by the input position command and will be the range with the rotations set in Pn26 added on both sides of the position command input range.

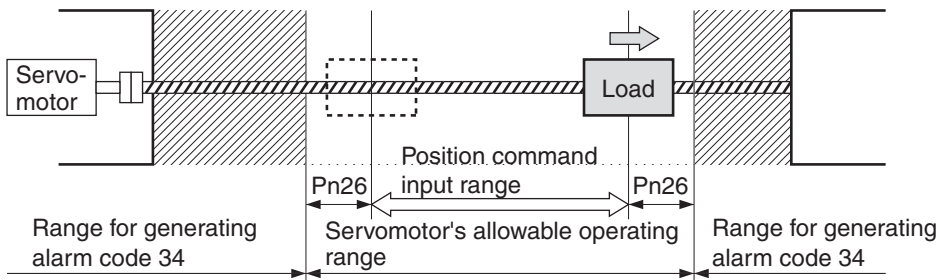

### ■ Left Side Operation (Servo ON)

When the position command to the left is input, the position command input range will further increase.

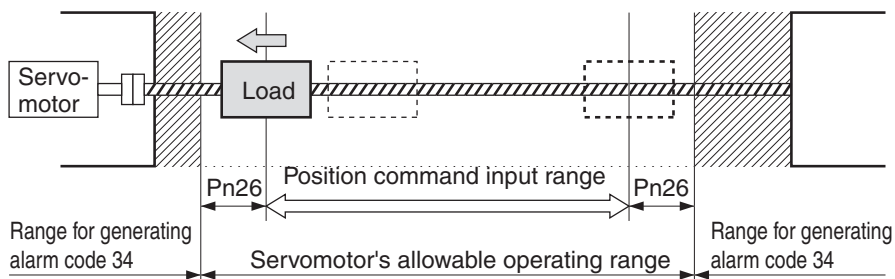

# 5-10 Brake Interlock

## Precautions for Using the Electromagnetic Brake

- The electromagnetic brake on a Servomotor with a brake is a nonexcitation brake designed for holding. Set the parameter to first stop the Servomotor, and then turn OFF the power supply to the brake.
- If the brake is applied while the Servomotor is rotating, the brake disk may become damaged due to friction, damaging the Servomotor.

## Function

- You can set the Brake Interlock Output (BKIR) timing to turn ON and OFF the electromagnetic brake.

## Parameters Requiring Settings

Parameter No.	Parameter name	Explanation	Reference page
Pn6A	Brake Timing when Stopped	Use this parameter to set the output timing of the Brake Interlock Output (BKIR).	5-90
Pn6B	Brake Timing during Operation	Pn6A: Delay time setting from BKIR OFF until servo OFF. Pn6B: Wait time setting from servo OFF until BKIR OFF.	5-91

## Operation

### ■ RUN Command Timing (When Servomotor Is Stopped)

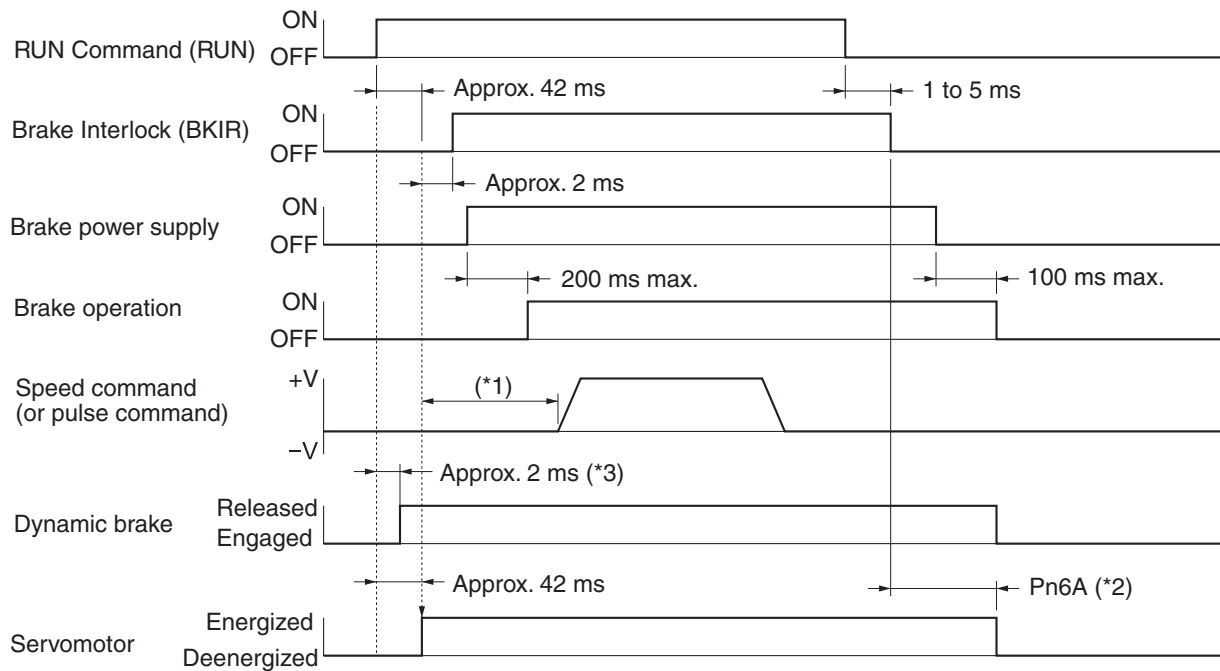

- \*1. The time from turning ON the brake power supply to the brake being released is 200 ms max. Take this delay into account and be sure the brake has been released before providing a speed command (pulse command).
- \*2. The time from turning OFF the brake power supply to the brake engaging is 100 ms max. If using the Servomotor on a vertical axis, take this delay into account and set the Brake Timing when Stopped (Pn6A) so that the Servomotor is deenergized after the brake has engaged.
- \*3. The Servo ON status will not occur until the Servomotor drops to 30 r/min or less.

### ■ Power Supply OFF Timing (When Servomotor Is Stopped)

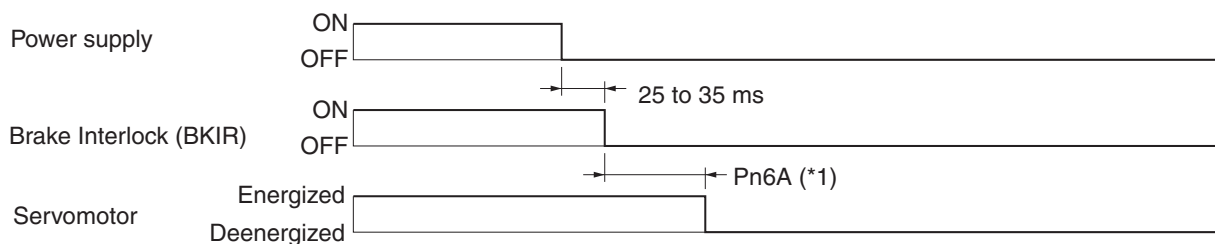

- \*1. The time from turning OFF the brake power supply to the brake engaging is 100 ms max. If using the Servomotor on a vertical axis, take this delay into account and set the Brake Timing when Stopped (Pn6A) so that the Servomotor is deenergized after the brake has engaged.

■ RUN Command, Errors, and Power Supply OFF Timing (When Servomotor Is Rotating)

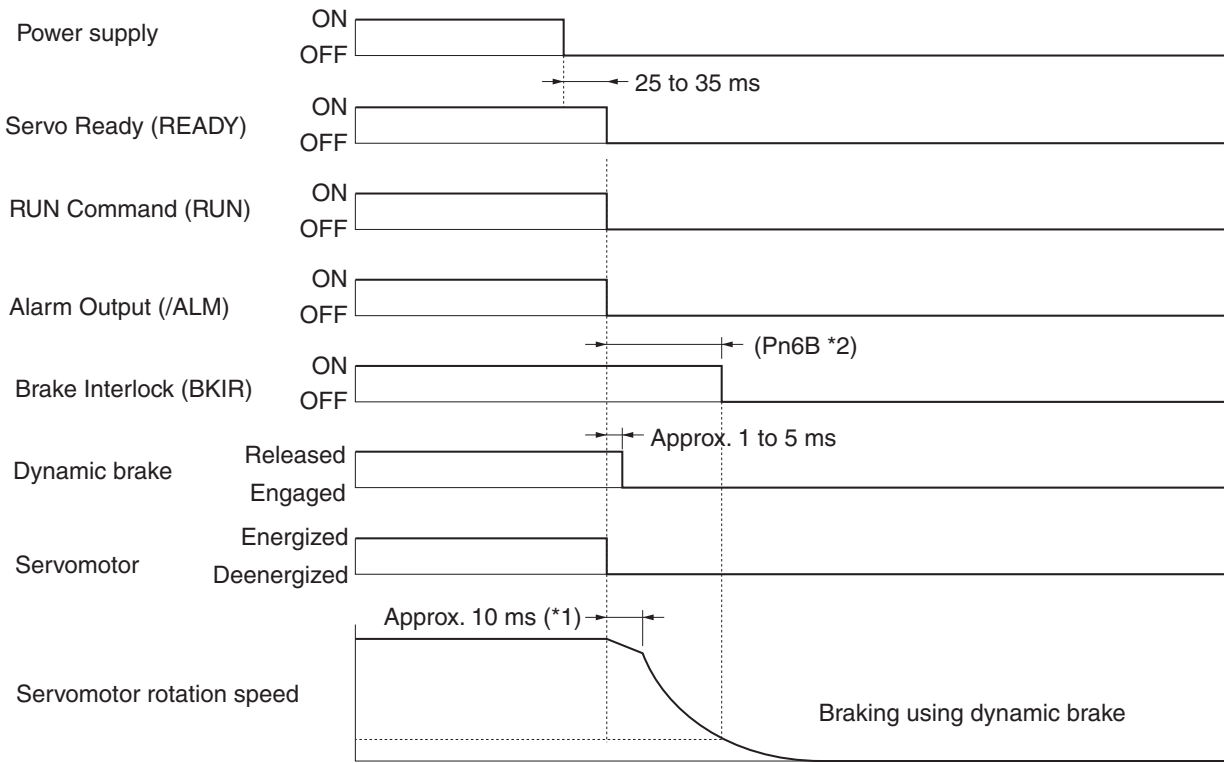

\*1. After the Servomotor is deenergized, it will rotate by inertia for approximately 10 ms until the dynamic brake operates.

\*2. The Brake Interlock (BKIR) signal will turn OFF when the Servomotor's rotation speed is 30 r/min. or lower, or the time set in the Brake Timing during Operation (Pn6B) has elapsed.



■ Alarm Clear (When Servo Is ON)

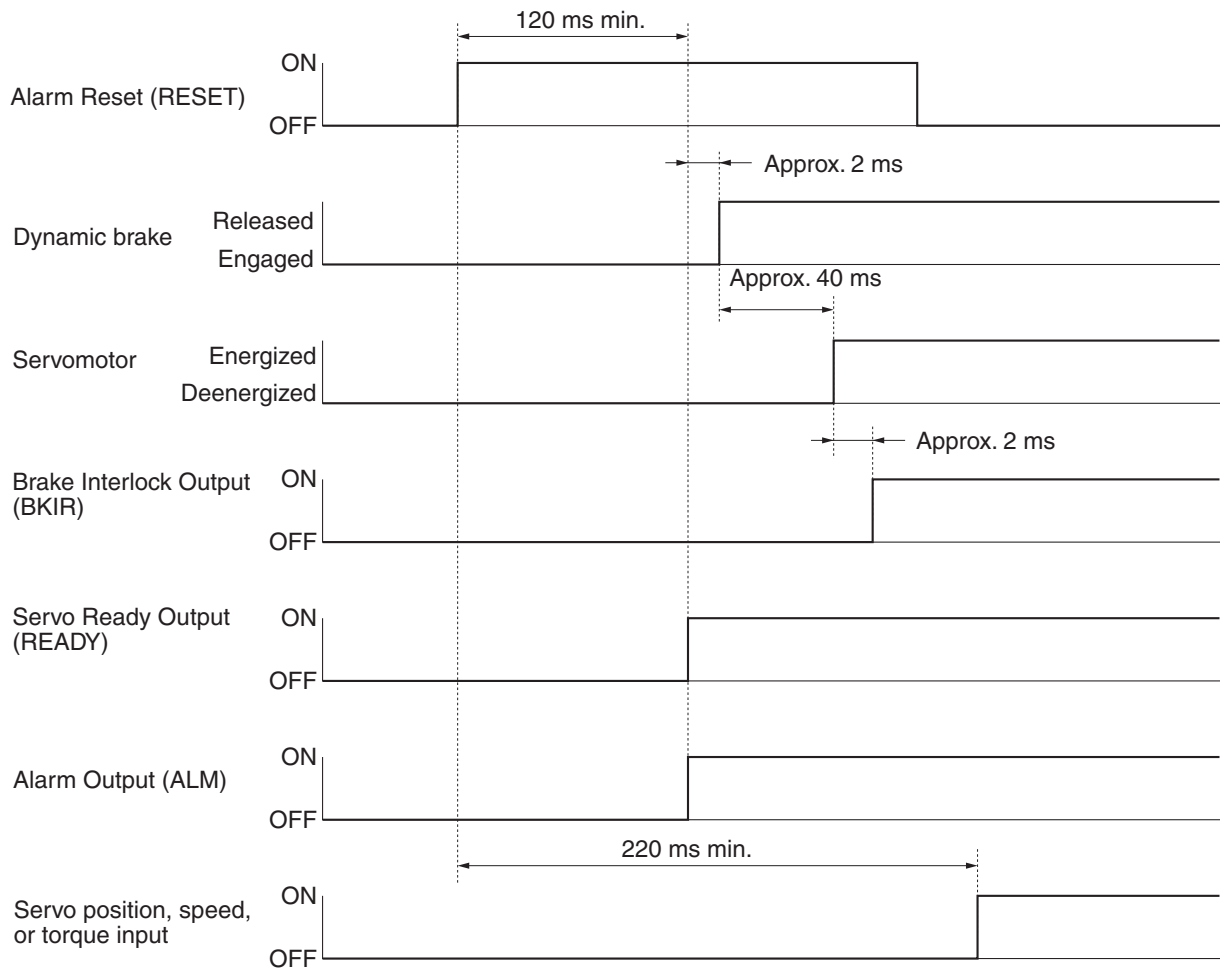

# 5-11 Gain Switching

## Function

- This function switches the speed loop and position loop gain. Enabled when Pn30 is set to 1 and Pn31 is not set to 1, 2, or 4, or when Pn36 is not set to 0 or 1 under Speed Control.
- If GSEL (gain switching) signal is not input, perform control using the Speed Loop Gain (Pn11), Speed Loop Integration Time Constant (Pn12), and Position Loop Gain (Pn10). If GSEL is input, perform control using the Speed Loop Gain 2 (Pn19), Speed Loop Integration Time Constant 2 (Pn1A), and Position Loop Gain 2 (Pn18).
- If the mechanical system inertia fluctuates too much, or if you want different responsiveness during operation and stoppage, you can perform applicable control using gain switching.
- If realtime autotuning is not effective (under the conditions shown below), the gain switching function will be useful.
  - When the load inertia fluctuates in 200 ms or less.
  - When rotation speed does not exceed 500 r/min., or output torque does not exceed 50% of the rated torque.
  - When external force is constantly applied, as with a vertical axis.

**Note** When No. 2 gain has been selected (i.e., GSEL ON), realtime autotuning will not operate normally. If using the gain switching function, set the Realtime Autotuning Mode Selection (Pn21) to 0 (not used).

## Parameters Requiring Settings

Parameter No.	Parameter name	Explanation	Reference page
Pn18	Position Loop Gain 2	Set the responsiveness of the position control system when gain 2 is selected.	5-61
Pn19	Speed Loop Gain 2	Set the responsiveness of the speed loop when gain 2 is selected.	5-61
Pn1A	Speed Loop Integration Time Constant 2	Set the integration time constant of the speed loop when gain 2 is selected.	5-62
Pn30	Gain Switching Input Operating Mode Selection	Set switching between PI and P operation for speed control or switching between gain 1 and gain 2. This parameter can be set if 0 to 2 is set for the Torque Limit Selection (Pn03) (setting: 1).	5-68
Pn31	Control Gain Switch 1 Setting	If 1 is set for the Gain Switching Input Operating Mode Selection (Pn30), set the switching conditions for gain 1 and gain 2 (setting: 0). If a composite mode is set, the setting of this parameter is valid when the first control mode is used.	5-69
Pn36	Control Gain Switch 2 Setting	Select the conditions for switching between gain 1 and gain 2 when the second control mode is used. The Gain Switching Input Operating Mode Selection (Pn30) must be set to 1 (enabled).	5-73

**Note** Adjust Pn18, Pn19, and Pn1A with GSEL turned ON according to 7-5 *Manual Tuning* on page 7-21. The Realtime Autotuning Machine Rigidity Selection (Pn22) cannot be applied to gain 2. Set the default values for adjustment referring to the table on page 7-16.

# 5-12 Torque Limit

## Function

- The torque output by the Servomotor can be limited.
- This function is effective in the following cases:
  - Pressing a moving part of a machine (such as a bending machine) against a workpiece with constant force.
  - Protecting the Servomotor and mechanical system from excessive force or torque.
- The torque limit method depends on the setting of Pn03.

## Parameters Requiring Settings

### Pn03 = 0

During operation, the torque is limited to the torque specified with the analog voltage or the torque set in the parameter, whichever is smaller.

- If a positive voltage between 0 and 10 V is applied to PCL (forward torque limit input), the torque will be limited for forward operation (+3 V/100%).
- If a negative voltage between 0 and -10 V is applied to NCL (reverse torque limit input), the torque will be limited for reverse operation (-3 V/100%).

For the parameter setting, the maximum torque is limited by Pn5E for both forward and reverse operation.

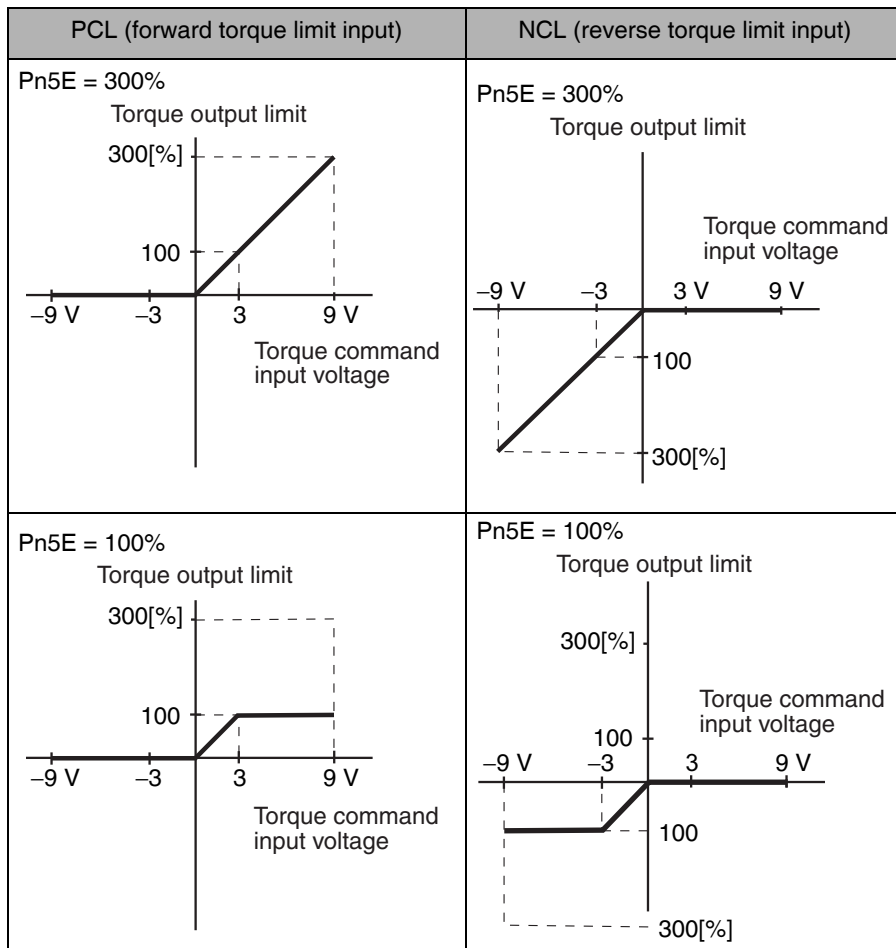

## 5-12 Torque Limit

### Pn03 = 1

Torque is limited during operation to a constant torque (parameter settings). For both forward and reverse operation, use Pn5E to limit the maximum torque.

### Pn03 = 2

Torque is limited during operation to a constant torque (parameter settings). To limit the maximum torque, use Pn5E for forward operation, and Pn5F for reverse operation.

### Pn03 = 3

The torque limit setting is switched by turning pin 27 ON and OFF.

- For both forward and reverse operation, use Pn5E to limit the maximum torque when pin 27 is OFF, and use Pn5F when pin 27 is ON.

## ■ Torque Limit Settings

- The setting range for the torque limit is 0 to 300 and the standard default setting is 300 except for the following combinations of Servo Drives and Servomotors.

Servo Drive	Applicable Servomotor	Maximum torque limit
R88D-GT15H	R88M-G90010T	225
R88D-GT30H	R88M-G2K010T	230
R88D-GT50H	R88M-G3K010T	235
	R88M-G4K510T	255
R88D-GT75H	R88M-G6K010T	256
	R88M-G7K515T	250

# 5-13 Soft Start

## Function

- This function accelerates and decelerates the Servomotor in the set acceleration and deceleration times.
- You can set the acceleration and deceleration independently of each other using the trapezoidal acceleration and deceleration curve.
- The soft start processes speed command input (REF) or internally set speed control switching to reduce impact during acceleration and deceleration.
- This function is effective for simple positioning and speed switching operations.
- Do not use this function for a position controller with an acceleration/deceleration function.

## Parameters Requiring Settings

Parameter No.	Parameter name	Explanation	Reference page
Pn58	Soft Start Acceleration Time	Set the time using the following formula. Setting = Acceleration time (setting × 2 ms) from 0 r/min to 1,000 r/min.	5-83
Pn59	Soft Start Deceleration Time	Set the time using the following formula. Setting = Deceleration time (setting × 2 ms) from 1,000 r/min to 0 r/min.	5-83

- If the soft start function is not used, set this parameter to 0 (default setting).
- The actual acceleration and deceleration time is as follows:

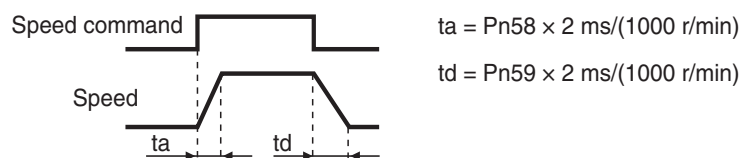

# 5-14 Position Command Filter

## Function

- Perform soft start processing for the command pulses using the selected filter to gently accelerate and decelerate.
- Select the filter characteristics using the Position Command Filter Time Constant Setting (Pn4C).
- This function is effective in the following cases:
  - There is no acceleration/deceleration function in the command pulse (controller).
  - The command pulse frequency changes abruptly, causing the machinery to vibrate during acceleration and deceleration.
  - The electronic gear setting is high ( $G1/G2 \geq 10$ )

## Parameters Requiring Settings

Parameter No.	Parameter name	Explanation	Reference page
Pn4C	Position Command Filter Time Constant Setting	This is a first-order lag filter for the command pulse input section. If the command pulses change abruptly, this filter can be used to reduce the stepping movement of the Servomotor. The larger the setting, the larger the time constant (setting range: 0 to 7).	5-79

## Operation Example

- The characteristics for each filter are shown below.
- Servomotor acceleration and deceleration are delayed further than the characteristics shown below due to position loop gain.

Acceleration:  $2/K_p$  (s); Deceleration:  $3/K_p$  (s);  $K_p$ : Position loop gain

### ■ Primary Filter

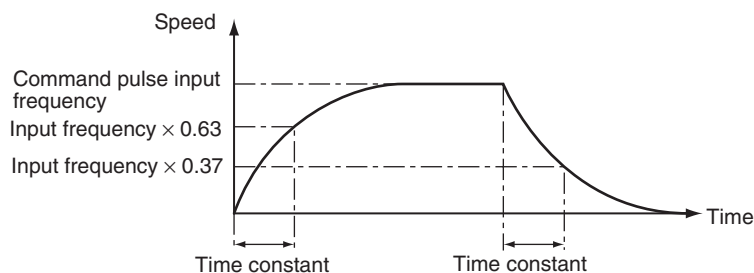

**Note** The time constant will be as follows according to the setting of Pn4C.

Pn4C	Time constant (ms)
0	Disabled
1	0.2
2	0.6
3	1.3
4	2.6
5	5.3
6	10.6
7	21.2

# 5-15 Speed Limit

## Function

- This function limits Servomotor rotation speed when torque control is used.
- Set a limit so that the Servomotor rotation speed does not exceed the maximum speed of the mechanical system.
- Outside of the speed limit range, a torque in proportion to the difference from the speed limit value is generated to slow down the Servomotor rotation speed. In such cases the number of Servomotor rotations does not necessarily match the speed limit value. (The number of Servomotor rotations varies depending on the load.)
- There are two methods that can be used for limiting the speed:
  - Apply a constant fixed speed limit in Torque Control Mode (parameter settings). The speed is limited using the No. 4 Internally Set Speed (Pn56).
  - Limit the speed with an analog voltage. Use the Speed Command Input (REF) as an Analog Speed Limit Input (VLIM).

## Parameters Requiring Settings

### Limiting the Speed to a Constant Speed in Torque Control Mode

- The speed will be limited according to the following parameter setting if the Torque Command/Speed Limit Selection (Pn5B) is set to 0.

Parameter No.	Parameter name	Explanation	Reference page
Pn56	No. 4 Internally Set Speed	Set the speed limit when torque control is used (setting range: -20,000 to 20,000 (r/min.))	5-82

### Limiting the Speed with Analog Voltage

- The Speed Command Input (REF) will be the Analog Speed Limit Input terminal if the Torque Command/Speed Limit Selection (Pn5B) is set to 1. Therefore, the speed can be limited on multiple levels.

Parameter No.	Parameter name	Explanation	Reference page
Pn50	Speed Command Scale	<p>Set the relation between the command input voltage and the rotation speed by using the slope.</p> <p>The graph plots Rotation speed (r/min.) on the vertical axis against Speed command voltage (V) on the horizontal axis. The horizontal axis is marked from -10 to 10 in increments of 2. The vertical axis has a horizontal line labeled 'Rated rotation'. A line passing through the origin (0,0) is labeled 'Default slope'. Several other lines with different slopes originate from the origin. One of these lines is labeled 'Rated rotation speed' with an arrow pointing to its end point on the horizontal axis.</p>	5-81

The default setting for Pn50 is 300, so the speed will be 3,000 r/min for an input of 10 V.

# 5-16 User Parameters

Set and check the user parameters in Parameter Setting Mode. Fully understand what the parameters mean and the setting procedures, and set the parameters according to the control system.

Some parameters are enabled by turning the power OFF and then ON again. After changing these parameters, turn OFF the power, confirm that the power indicator has gone OFF, and then turn ON the power again.

## Setting and Checking Parameters





### ■ Overview

Use the following procedure to set or check parameters.

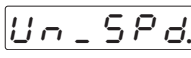

- Go to Parameter Setting Mode. Press the Data key, and then press the Mode key once.
- Set the parameter number (Pn□□) using the Increment and Decrement keys.
- Display the parameter setting by pressing the Data key.
- Change the parameter setting using the Increment, Decrement, and Shift keys.
- Save the changed setting to memory and return to the parameter number display by pressing the Data key.

### ■ Operating Procedures

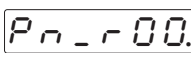
#### Displaying Parameter Setting Mode

PR02G keys	Front panel keys	Display example	Explanation
			The default display is displayed.
			Press the Data key to display Monitor Mode.
			Press the Mode key to display Parameter Setting Mode.

#### Setting the Parameter Number

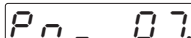
PR02G keys	Front panel keys	Display example	Explanation
			Set the number of the parameter to be set or checked.



### Displaying Parameter Settings

PR02G keys	Front panel keys	Display example	Explanation
			The parameter number will be displayed.
			Press the Data key. The setting of the parameter will be displayed.

### Changing Parameter Settings

- The following operation is not required if you are only checking a parameter setting.

PR02G keys	Front panel keys	Display example	Explanation
			The present setting will be displayed.
			Use the Shift, Increment, and Decrement keys to change the setting. The Shift key is used to change the digit.

### Saving the New Setting to Memory and Returning to the Parameter Number Display

- The following operation is not required if you are only checking a parameter setting.

PR02G keys	Front panel keys	Display example	Explanation
			Press the Data key. The new parameter setting will be saved and the parameter number will be displayed again.

## Parameter Tables

- Some parameters are enabled by turning the power OFF and then ON again. (Those parameters are indicated in the table.) After changing these parameters, turn OFF the power, confirm that the power indicator has gone OFF, and then turn ON the power again.
- Do not change the parameters or settings marked “Reserved”.

### ■ Function Selection Parameters

Pn No.	Parameter name	Setting	Explanation	Default setting	Unit	Setting range	Power OFF→ON	
00	Unit No. Setting	Set the unit number.		1	---	0 to 15	Yes	
01	Default Display	Set the data to display on the Parameter Unit when the power supply is turned ON.		1		0 to 17	Yes	
		0	Position deviation					Pulses
		1	Servomotor rotation speed					r/min
		2	Torque output					%
		3	Control mode					---
		4	I/O signal status					---
		5	Alarm code and history					---
		6	Software version					---
		7	Warning display					---
		8	Regeneration load ratio					%
		9	Overload load ratio					%
		10	Inertia ratio					%
		11	Total feedback pulses					Pulses
		12	Total command pulses					Pulses
		13	Reserved					---
		14	Reserved					---
		15	Automatic Servomotor recognition display					---
		16	Analog input value					---
17	Reason for no rotation	---						
02	Control Mode Selection	Set the control mode to be used.		0	---	0 to 6	Yes	
		0	Position					
		1	Speed					
		2	Torque					
		3	Position/speed					
		4	Position/torque					
		5	Speed/torque					
		6	Reserved					

5  
Operating Functions

Pn No.	Parameter name	Setting	Explanation	Default setting	Unit	Setting range	Power OFF→ON
03	Torque Limit Selection		Set the torque limit method for forward and reverse operation.	1	---	0 to 3	---
		0	Use PCL and NCL as analog torque limit inputs.				
		1	Use Pn5E as the limit value for forward and reverse operation.				
		2	Forward: Use Pn5E, Reverse: Use Pn5F.				
		3	GSEL/TLSEL input is open: Use Pn5E, Input is closed: Use Pn5F.				
04	Drive Prohibit Input Selection		You can stop the Servomotor from rotating beyond the device's travel distance range by setting limit inputs.	1	---	0 to 2	Yes
		0	POT input and NOT input enabled.				
		1	POT input and NOT input disabled.				
		2	POT input and NOT input enabled (alarm code 38 appears).				
05	Command Speed Selection		Select the speed command when using speed control.	0	---	0 to 3	---
		0	Speed command input (REF)				
		1	No. 1 Internally Set Speed to No. 4 Internally Set Speed (Pn53 to Pn56)				
		2	No. 1 Internally Set Speed to No. 3 Internally Set Speed (Pn53 to Pn55) and External Speed Command (REF)				
		3	No. 1 Internally Set Speed to No. 8 Internally Set Speed (Pn53 to Pn56 and Pn74 to Pn77)				
06	Zero Speed Designation/Speed Command Direction Switch		Set the function of the Zero-speed Designation Input (VZERO).	0	---	0 to 2	---
		0	The zero-speed designation input will be ignored, and a zero-speed designation will not be detected.				
		1	The zero-speed designation input will be enabled, and the speed command will be assumed to be zero when the connection between the input and common is open.				
		2	Used as the speed command sign.				

## 5-16 User Parameters

Pn No.	Parameter name	Setting	Explanation	Default setting	Unit	Setting range	Power OFF→ON
07	SP Selection		Select the relation between the output voltage level and the speed.	3	---	0 to 9	---
		0	Actual Servomotor speed: 6 V/47 r/min				
		1	Actual Servomotor speed: 6 V/188 r/min				
		2	Actual Servomotor speed: 6 V/750 r/min				
		3	Actual Servomotor speed: 6 V/3000 r/min				
		4	Actual Servomotor speed: 1.5 V/3000 r/min				
		5	Command speed: 6 V/47 r/min				
		6	Command speed: 6 V/188 r/min				
		7	Command speed: 6 V/750 r/min				
		8	Command speed: 6 V/3000 r/min				
		9	Command speed: 1.5 V/3000 r/min				
08	IM Selection		Select the relation between the output voltage level and the torque or number of pulses.	0	---	0 to 12	---
		0	Torque command: 3 V/rated (100%) torque				
		1	Position deviation: 3 V/31 pulses				
		2	Position deviation: 3 V/125 pulses				
		3	Position deviation: 3 V/500 pulses				
		4	Position deviation: 3 V/2000 pulses				
		5	Position deviation: 3 V/8000 pulses				
		6	Reserved				
		7	Reserved				
		8	Reserved				
		9	Reserved				
		10	Reserved				
		11	Torque command: 3 V/200% torque				
12	Torque command: 3 V/400% torque						

5

Operating Functions

Pn No.	Parameter name	Setting	Explanation	Default setting	Unit	Setting range	Power OFF→ON
09	General-purpose Output 2 Selection	Assign the function of General-purpose Output 2 (OUTM2).		0	---	0 to 8	---
		0	Output during torque limit				
		1	Zero speed detection output				
		2	Warning output for regeneration overload, overload, absolute encoder battery, or fan lock.				
		3	Regeneration overload warning output				
		4	Overload warning				
		5	Absolute encoder battery warning output				
		6	Fan lock warning output				
		7	Reserved				
		8	Speed conformity output				
0A	General-purpose Output 1 Selection	Assign the function of General-purpose Output 1 (OUTM1).		1	---	0 to 8	---
		0	Output during torque limit				
		1	Zero speed detection output				
		2	Warning output for regeneration overload, overload, absolute encoder battery, or fan lock.				
		3	Regeneration overload warning output				
		4	Overload warning				
		5	Absolute encoder battery warning output				
		6	Fan lock warning output				
		7	Reserved				
		8	Speed conformity output				
0B	Operation Switch When Using Absolute Encoder	Set the operating method for the 17-bit absolute encoder.		0	---	0 to 2	Yes
		0	Use as absolute encoder.				
		1	Use as incremental encoder.				
		2	Use as absolute encoder but ignore multi-turn counter overflow.				
0C	RS-232 Baud Rate Setting	Select the baud rate for the RS-232 port.		2	---	0 to 5	Yes
		0	2,400 bps				
		1	4,800 bps				
		2	9,600 bps				
		3	19,200 bps				
		4	38,400 bps				
		5	57,600 bps				

## 5-16 User Parameters

Pn No.	Parameter name	Setting	Explanation	Default setting	Unit	Setting range	Power OFF→ON
0D	RS-485 Baud Rate Setting		Select the baud rate for RS-485 communications.	2	---	0 to 5	Yes
		0	2,400 bps				
		1	4,800 bps				
		2	9,600 bps				
		3	19,200 bps				
		4	38,400 bps				
		5	57,600 bps				
0E	Front Key Protection Setting		Front panel key operation can be limited to Monitor Mode.	0	---	0 to 1	Yes
		0	All enabled				
		1	Limited to Monitor Mode				
0F	Reserved		(Do not change setting.)	---	---	---	---

## ■ Gain Parameters

Pn No.	Parameter name	Setting	Explanation	Default setting	Unit	Setting range	Power OFF→ON
10	Position Loop Gain		Set to adjust position control system responsiveness.	40	1/s	0 to 3000	---
11	Speed Loop Gain		Set to adjust speed loop responsiveness.	50	Hz	1 to 3500	---
12	Speed Loop Integration Time Constant		Set to adjust the speed loop integration time constant.	20	ms	1 to 1000	---
13	Speed Feedback Filter Time Constant		The encoder signal is converted to the speed signal via the low pass filter.	0	---	0 to 5	---
14	Torque Command Filter Time Constant		Set to adjust the first-order lag filter time constant for the torque command section.	80	0.01 ms	0 to 2500	---
15	Feed-forward Amount		Set the position control feed-forward compensation value.	300	0.1%	-2000 to 2000	---
16	Feed-forward Command Filter		Set the time constant of the first-order lag filter used in the speed feed-forward section.	100	0.01 ms	0 to 6400	---
17	Reserved		(Do not change setting.)	---	---	---	---
18	Position Loop Gain 2		Set to adjust position control system responsiveness.	20	1/s	0 to 3000	---
19	Speed Loop Gain 2		Set to adjust speed loop responsiveness.	80	Hz	1 to 3500	---
1A	Speed Loop Integration Time Constant 2		Set to adjust the speed loop integration time constant.	50	ms	1 to 1000	---
1B	Speed Feedback Filter Time Constant 2		The encoder signal is converted to the speed signal via the low pass filter.	0	---	0 to 5	---
1C	Torque Command Filter Time Constant 2		Set to adjust the first-order lag filter time constant for the torque command section.	100	0.01 ms	0 to 2500	---
1D	Notch Filter 1 Frequency		Set the notch frequency of the resonance suppression notch filter.	1500	Hz	100 to 1500	---
1E	Notch Filter 1 Width		Set the width to one of five levels for the resonance suppression notch filter. Normally, use the default setting.	2	---	0 to 4	---
1F	Reserved		(Do not change setting.)	---	---	---	---
20	Inertia Ratio		Set the ratio between the mechanical system inertia and the Servomotor rotor inertia.	300	%	0 to 10000	---

Pn No.	Parameter name	Setting	Explanation	Default setting	Unit	Setting range	Power OFF→ON
21	Realtime Autotuning Mode Selection	Set the operating mode for realtime autotuning.		0	---	0 to 7	---
		0	Realtime autotuning is not used.				
		1	Realtime autotuning is used in normal mode. Use this setting if there are almost no changes in load inertia during operation.				
		2	Realtime autotuning is used in normal mode. Use this setting if there are gradual changes in load inertia during operation.				
		3	Realtime autotuning is used in normal mode. Use this setting if there are sudden changes in load inertia during operation.				
		4	Realtime autotuning is used in vertical axis mode. Use this setting if there are almost no changes in load inertia during operation.				
		5	Realtime autotuning is used in vertical axis mode. Use this setting if there are gradual changes in load inertia during operation.				
		6	Realtime autotuning is used in vertical axis mode. Use this setting if there are sudden changes in load inertia during operation.				
		7	Set to use realtime autotuning without switching the gain.				
22	Realtime Autotuning Machine Rigidity Selection	Set the machine rigidity to one of 16 levels during realtime autotuning. The higher the machine rigidity, the greater the setting needs to be. The higher the setting, the higher the responsiveness. When the Parameter Unit is used, 0 cannot be set.		2	---	0 to F	---
23	Adaptive Filter Selection	Enable or disable the adaptive filter.		0	---	0 to 2	---
		0	Adaptive filter disabled.				
		1	Adaptive filter enabled. Adaptive operation performed.				
		2	Adaptive filter enabled. Adaptive operation will not be performed (i.e., it will be held).				
24	Vibration Filter Selection	Vibration filters 1 and 2 can be switched.		0	---	0 to 2	---
		0	No switching. (Both filter 1 and filter 2 are enabled.)				
		1	Switching with the DFSEL/PNSEL input. Open: Vibration filter 1 Closed: Vibration filter 2				
		2	Switching with command direction. Forward: Vibration filter 1 Reverse: Vibration filter 2				



Pn No.	Parameter name	Setting	Explanation	Default setting	Unit	Setting range	Power OFF→ON
25	Autotuning Operation Setting	Set the operating pattern for normal mode autotuning.		0	---	0 to 7	---
		0	Rotation direction: Forward to reverse, two rotations				
		1	Rotation direction: Reverse to forward, two rotations				
		2	Rotation direction: Forward to forward, two rotations				
		3	Rotation direction: Reverse to reverse, two rotations				
		4	Rotation direction: Forward to reverse, one rotation				
		5	Rotation direction: Reverse to forward, one rotation				
		6	Rotation direction: Forward to forward, one rotation				
		7	Rotation direction: Reverse to reverse, one rotation				
26	Overrun Limit Setting	Set the allowable operating range for the Servomotor. The overrun limit function is disabled if the parameter is set to 0.		10	0.1 rotation	0 to 1000	---
27	Instantaneous Speed Observer Setting	Set the instantaneous speed observer.		0	---	0 to 1	---
		0	Disabled				
		1	Enabled				
28	Notch Filter 2 Frequency	Set the notch frequency of the resonance suppression notch filter.		1500	Hz	100 to 1500	---
29	Notch Filter 2 Width	Set the notch filter width to one of five levels for the resonance suppression notch filter. Normally, use the default setting.		2	---	0 to 4	---
2A	Notch Filter 2 Depth	Set the depth of the resonance suppression notch filter.		0	---	0 to 99	---
2B	Vibration Frequency 1	Set vibration frequency 1 to suppress vibration at the end of the load in damping control.		0	0.1 Hz	0 to 2000	---
2C	Vibration Filter 1 Setting	Set vibration filter 1 to suppress vibration at the end of the load in damping control.		0	0.1 Hz	-200 to 2000	---
2D	Vibration Frequency 2	Set vibration frequency 2 to suppress vibration at the end of the load in damping control.		0	0.1 Hz	0 to 2000	---
2E	Vibration Filter 2 Setting	Set vibration filter 2 to suppress vibration at the end of the load in damping control.		0	0.1 Hz	-200 to 2000	---
2F	Adaptive Filter Table Number Display	Displays the table entry number corresponding to the frequency for the adaptive filter. This parameter is set automatically and cannot be changed if the adaptive filter is enabled (i.e., if Real-time Autotuning Mode Selection (Pn21) is 1 to 3 or 7).		0	---	0 to 64	---

## 5-16 User Parameters

Pn No.	Parameter name	Setting	Explanation	Default setting	Unit	Setting range	Power OFF → ON
30	Gain Switching Input Operating Mode Selection		Enable or disable gain switching. If gain switching is enabled, the setting of the Control Gain Switch Setting (Pn31) is used as the condition for switching between gain 1 and gain 2.	1	---	0 to 1	---
		0	Disabled. The gain set in Pn10 to Pn14 is used, and the Gain Switching Input (GSEL) will be used to switch between PI operation and P operation.				
		1	Enabled. The gain will be switched between gain 1 (Pn10 to Pn14) and gain 2 (Pn18 to Pn1C).				
31	Control Gain Switch 1 Setting		Select the condition for switching between gain 1 and gain 2. The details depend on the control mode. If a composite mode is set, the setting of this parameter is valid when the first control mode is used. The Gain Switching Input Operating Mode Selection (Pn30) must be set to 1 (enabled).	0	---	0 to 10	---
		0	Always gain 1				
		1	Always gain 2				
		2	Switching using Gain Switching Input (GSEL)				
		3	Amount of change in torque command				
		4	Always gain 1				
		5	Command speed				
		6	Amount of position deviation				
		7	Command pulses received				
		8	Positioning Completed Signal (INP) OFF				
		9	Actual Servomotor speed				
10	Combination of command pulse input and speed						
32	Gain Switch 1 Time		This parameter is enabled when the Control Gain Switch 1 Setting (Pn31) is 3 to 10. Set the delay time from the moment the condition set in the Control Gain Switch 1 Setting (Pn31) is not met until returning to gain 1.	30	166 μs	0 to 10000	---
33	Gain Switch 1 Level Setting		This parameter is enabled when the Control Gain Switch 1 Setting (Pn31) is 3 to 6, 9, or 10. Set the judgment level for switching between gain 1 and gain 2. The unit for the setting depends on the condition set in the Control Gain Switch 1 Setting (Pn31).	600	---	0 to 20000	---
34	Gain Switch 1 Hysteresis Setting		Set the hysteresis width above and below the judgment level set in the Gain Switch 1 Level Setting (Pn33).	50	---	0 to 20000	---
35	Position Loop Gain Switching Time		When switching between gain 1 and gain 2 is enabled, set the phased switching time only for the position loop gain at gain switching.	20	166 μs	0 to 10000	---

Pn No.	Parameter name	Setting	Explanation	Default setting	Unit	Setting range	Power OFF→ON
36	Control Gain Switch 2 Setting		Select the condition for switching between gain 1 and gain 2 in the second control mode. The Gain Switching Input Operating Mode Selection (Pn30) must be set to 1 (enabled).	0	---	0 to 5	---
		0	Always gain 1				
		1	Always gain 2				
		2	Switching using gain switching input (GSEL)				
		3	Amount of change in torque command				
		4	Amount of change in speed command				
		5	Command speed				
37	Gain Switch 2 Time		This parameter is enabled when Control Gain Switch 2 Setting (Pn36) is 3 to 5. Set the delay time for returning from gain 2 to gain 1.	30	166 μs	0 to 10000	---
38	Gain Switch 2 Level Setting		This parameter is enabled when Control Gain Switch 2 Setting (Pn36) is 3 to 5. Set the judgment level for switching between gain 1 and gain 2. The unit depends on the setting of Control Gain Switch 2 Setting (Pn36).	0	---	0 to 20000	---
39	Gain Switch 2 Hysteresis Setting		Set the hysteresis width above and below the judgment level set in the Gain Switch 2 Level Setting (Pn38). The unit depends on the setting of the Control Gain Switch 2 Setting (Pn36).	0	---	0 to 20000	---
3A	Reserved		(Do not change setting.)	---	---	---	---
3B	Reserved		(Do not change setting.)	---	---	---	---
3C	Reserved		(Do not change setting.)	---	---	---	---
3D	Jog Speed		Set the speed for jogging.	200	r/min	0 to 500	---
3E	Reserved		(Do not change setting.)	---	---	---	---
3F	Reserved		(Do not change setting.)	---	---	---	---

■ Position Control Parameters

Pn No.	Parameter name	Setting	Explanation	Default setting	Unit	Setting range	Power OFF→ON
40	Command Pulse Input Selection	Selects whether to use photocoupler or line-driver-only input for the command pulse input. When using a Servo Relay Unit cable, set to 0 (photocoupler input).		0	---	0 to 1	Yes
		0	Photocoupler				
		1	Input for line driver only				
41	Command Pulse Rotation Direction Switch	Set the Servomotor rotation direction for the command pulse input.		0	---	0 to 1	Yes
		0	The Servomotor rotates in the direction specified by the command pulse.				
		1	The Servomotor rotates in the opposite direction from the direction specified by the command pulse.				
42	Command Pulse Mode	Set the form of the pulse inputs sent as command to the Servo Drive from a position controller.		1	---	0 to 3	Yes
		0	90° phase difference (phase A/B) signal inputs				
		1	Forward pulse and reverse pulse inputs				
		2	90° phase difference (phase A/B) signal inputs				
		3	Feed pulses and forward/reverse signal input				
43	Command Pulse Prohibited Input Setting	Enable or disable the pulse disable input (IPG).		1	---	0 to 1	---
		0	Enabled				
		1	Disabled				
44	Encoder Divider Numerator Setting	Set the number of encoder pulses (+A, -A, -B, +B) output from the Servo Drive for each Servomotor rotation.		2500	---	1 to 32767	Yes
45	Encoder Divider Denominator Setting			0	---	0 to 32767	Yes
46	Encoder Output Direction Switch	Set the phase-B logic for pulse output (-B, +B).		0	---	0 to 1	Yes
		0	Phase-B output: Not reversed.				
		1	Phase-B output: Reversed.				
47	Reserved	(Do not change setting.)		---	---	---	---

Pn No.	Parameter name	Setting	Explanation	Default setting	Unit	Setting range	Power OFF→ON
48	Electronic Gear Ratio Numerator 1		Set the pulse rate for command pulses and Servomotor travel distance. If Pn48 or Pn49 is 0, the encoder resolution is set to a numerator.  $\frac{\text{Electronic Gear Ratio Numerator 1 (Pn48) \quad \text{Electronic Gear Ratio Numerator Exponent (Pn4A)}}{\text{Electronic Gear Ratio Numerator 2 (Pn49)} \times 2}$ Electronic Gear Ratio Denominator (Pn4B)	0	---	0 to 10000	---
49	Electronic Gear Ratio Numerator 2			0	---	0 to 10000	---
4A	Electronic Gear Ratio Numerator Exponent			0	---	0 to 17	---
4B	Electronic Gear Ratio Denominator			10000	---	1 to 10000	---
4C	Position Command Filter Time Constant Setting		Set the time constant for the first-order lag filter for the command pulse input. If the parameter is set to 0, the filter will not function. The larger the setting, the larger the time constant.	0	---	0 to 7	---
4D	Smoothing Filter Setting		Select the FIR filter time constant used for the command pulse input. The higher the setting, the smoother the command pulses.	0	---	0 to 31	Yes
4E	Deviation Counter Reset Condition Setting		Set the deviation counter reset conditions.	1	---	0 to 2	---
		0	Clears the deviation counter when the signal is closed for 100 μs or longer.				
		1	Clears the deviation counter on the falling edge of the signal (open and then closed for 100 μs or longer).				
		2	Disabled				
4F	Reserved		(Do not change setting.)	---	---	---	---

■ Speed and Torque Control Parameters

Pn No.	Parameter name	Setting	Explanation	Default setting	Unit	Setting range	Power OFF→ON
50	Speed Command Scale		Set the relation between the voltage applied to the Speed Command Input (REF) and the Servomotor speed.	300	(r/min) /V	10 to 2000	---
51	Command Speed Rotation Direction Switch		Set to reverse the polarity of the speed command input (REF).	0	---	0 to 1	---
		0	Forward				
		1	Reverse				
52	Speed Command Offset Adjustment		Set to adjust the offset of the Speed Command Input (REF).	0	0.3 mV	-2047 to 2047	---
53	No. 1 Internally Set Speed		Set the No. 1 internally set rotation speed.	100	r/min	-20000 to 20000	---
54	No. 2 Internally Set Speed		Set the No. 2 internally set rotation speed.	200	r/min	-20000 to 20000	---
55	No. 3 Internally Set Speed		Set the No. 3 internally set rotation speed.	300	r/min	-20000 to 20000	---
56	No. 4 Internally Set Speed		Set the No. 4 internally set rotation speed. For torque control (when Pn5B = 0), set the speed limit.	50	r/min	-20000 to 20000	---
74	No. 5 Internally Set Speed		Set the No. 5 internally set rotation speed.	500	r/min	-20000 to 20000	---
75	No. 6 Internally Set Speed		Set the No. 6 internally set rotation speed.	600	r/min	-20000 to 20000	---
76	No. 7 Internally Set Speed		Set the No. 7 internally set rotation speed.	700	r/min	-20000 to 20000	---
77	No. 8 Internally Set Speed		Set the No. 8 internally set rotation speed.	800	r/min	-20000 to 20000	---
57	Speed Command Filter Time Constant		Set the first-order lag filter time constant in the Speed Command Input (REF: CN1 pin 14).	0	0.01 ms	0 to 6400	---
58	Soft Start Acceleration Time		Set the acceleration time for the speed command.	0	2 ms (1000 r/min)	0 to 5000	---
59	Soft Start Deceleration Time		Set the deceleration time for the speed command.	0	2 ms (1000 r/min)	0 to 5000	---

5

Operating Functions

Pn No.	Parameter name	Setting	Explanation	Default setting	Unit	Setting range	Power OFF→ON
5A	S-curve Acceleration/Deceleration Time Setting		Set the pseudo-S-curve acceleration/deceleration value to add to the speed command to enable smooth operation.	0	2 ms	0 to 500	---
5B	Torque Command/Speed Limit Selection		Select the input for the torque command and speed limit. For the settings and control mode, refer to the description of the <i>Torque Command/Speed Limit Selection</i> on page 5-84.	0	---	0 to 1	---
5C	Torque Command Scale		Set the relation between the voltage applied to the torque command input (TREF1 or TREF2) and the Servomotor's output torque.	30	0.1 V/ 100%	10 to 100	---
5D	Torque Output Direction Switch		Set to reverse the polarity of the Torque Command Input (REF/TREF1 or PCL/TREF2).	0	---	0 to 1	---
		0	Forward				
		1	Reverse				
5E	No. 1 Torque Limit		Set the limit to the Servomotor's maximum torque.	300	%	0 to 500	---
5F	No. 2 Torque Limit		Set the limit to the Servomotor's maximum torque.	100	%	0 to 500	---

■ Sequence Parameters

Pn No.	Parameter name	Setting	Explanation	Default setting	Unit	Setting range	Power OFF→ON
60	Positioning Completion Range		Set the range for the Positioning Completed Output (INP).	25	Pulse	0 to 32767	---
61	Zero Speed Detection		Set the rotation speed to output for the general-purpose output (zero speed detection output or speed coincidence output).	20	r/min	10 to 20000	---
62	Rotation Speed for Motor Rotation Detection		Set the rotation speed for the Servomotor Rotation Detection Output (TGON) for Internally Set Speed Control.	50	r/min	10 to 20000	---
63	Positioning Completion Condition Setting		Set the operation for positioning completion output (INP).	0	---	0 to 3	---
		0	Positioning completion output turns ON when the position deviation is within the Positioning Completion Range (Pn60).				
		1	Positioning completion output turns ON when the position deviation is within the Positioning Completion Range (Pn60) and there is no position command.				
		2	Positioning completion output turns ON when the zero speed detection signal is ON and the position deviation is within the Positioning Completion Range (Pn60) and there is no position command.				
		3	Positioning completion output turns ON when the position deviation is within the Positioning Completion Range (Pn60) and there is no position command. The ON status will then be held until the next position command is received.				
64	Reserved		(Do not change setting.)	---	---	---	---
65	Undervoltage Alarm Selection		Select whether to activate the main power supply undervoltage function (alarm code 13) if the main power supply is interrupted for the Momentary Hold Time (Pn6D) during Servo ON.	1	---	0 to 1	---
		0	A main power supply undervoltage alarm (alarm code 13) is not generated and the Servomotor turns OFF. When the main power supply turns ON again, the Servo ON status returns.				
		1	An error is generated for a main power supply undervoltage alarm (alarm code 13).				

5

Operating Functions



Pn No.	Parameter name	Setting	Explanation	Default setting	Unit	Setting range	Power OFF→ON
66	Stop Selection for Drive Prohibition Input		Set the operation used to decelerate to a stop after the Forward Drive Prohibit Input (POT) or Reverse Drive Prohibit Input (NOT) has been received.	0	---	0 to 2	Yes
		0	The torque in the drive prohibit direction is disabled, and the dynamic brake is activated.				
		1	The torque in the drive prohibit direction is disabled, and free-run deceleration is performed.				
		2	The torque in the drive prohibit direction is disabled, and an emergency stop is performed.				
67	Stop Selection with Main Power OFF		Set one of the following operations to be performed after the main power supply is cut off if the Undervoltage Alarm Selection (Pn65) is set to 0. ♦ Operation during deceleration and after stopping ♦ Clearing the deviation counter	0	---	0 to 9	---
		0	During deceleration: Dynamic brake After stopping: Dynamic brake Deviation counter: Clear				
		1	During deceleration: Free run After stopping: Dynamic brake Deviation counter: Clear				
		2	During deceleration: Dynamic brake After stopping: Servo free Deviation counter: Clear				
		3	During deceleration: Free run After stopping: Servo free Deviation counter: Clear				
		4	During deceleration: Dynamic brake After stopping: Dynamic brake Deviation counter: Hold				
		5	During deceleration: Free run After stopping: Dynamic brake Deviation counter: Hold				
		6	During deceleration: Dynamic brake After stopping: Servo free Deviation counter: Hold				
		7	During deceleration: Free run After stopping: Servo free Deviation counter: Hold				
		8	During deceleration: Emergency stop After stopping: Dynamic brake Deviation counter: Clear				
		9	During deceleration: Emergency stop After stopping: Servo free Deviation counter: Clear				

Pn No.	Parameter name	Setting	Explanation	Default setting	Unit	Setting range	Power OFF→ON
68	Stop Selection for Alarm Generation		Set the operation to be performed after stopping or during deceleration when any protective function of the Servo Drive operates and an error occurs.	0	---	0 to 3	---
		0	During deceleration: Dynamic brake After stopping: Dynamic brake				
		1	During deceleration: Free run After stopping: Dynamic brake				
		2	During deceleration: Dynamic brake After stopping: Servo free				
		3	During deceleration: Free run After stopping: Servo free				
69	Stop Selection with Servo OFF		Set the operation to be performed after the Servomotor turns OFF (i.e., RUN ON to OFF). The relation between set values, operation, and deviation counter processing for this parameter is the same as for the Stop Selection with Main Power OFF (Pn67).	0	---	0 to 9	---
6A	Brake Timing when Stopped		When the Servomotor is stopped and the RUN Command Input (RUN) is turned OFF, the Brake Interlock Signal (BKIR) will turn OFF, and the Servomotor will turn OFF after waiting for the time period set for this parameter (i.e., setting × 2 ms).	10	2 ms	0 to 100	---
6B	Brake Timing during Operation		When the Servomotor is stopped and the RUN Command Input (RUN) is turned OFF, the Servomotor will decelerate to reduce rotation speed, and the Brake Interlock Signal (BKIR) will turn OFF after the set time for the parameter (i.e., setting × 2 ms) has elapsed. BKIR will also turn OFF if the speed drops to 30 r/min or lower before the set time elapses.	50	2 ms	0 to 100	---
6C	Regeneration Resistor Selection		Set whether to use a built-in resistor or to add an External Regeneration Resistor.	0	---	0 to 3	Yes
		0	Regeneration resistor used: Built-in resistor The regeneration processing circuit will operate and the regeneration overload (alarm code 18) will be enabled according to the internal resistance (with approximately 1% duty).				
		1	Regeneration resistor used: External resistor The regeneration processing circuit will operate, and regeneration overload (alarm code 18) will cause a trip when the operating rate of the regeneration resistor exceeds 10%.				
		2	Regeneration resistor used: External resistor The regeneration processing circuit will operate, but regeneration overload (alarm code 18) will not occur.				
		3	Regeneration resistor used: None The regeneration processing circuit and regeneration overload (alarm code 18) will not operate, and all regenerative energy will be processed by the built-in capacitor.				
6D	Momentary Hold Time		Set the amount of time required until shutoff is detected if the main power supply continues to shut off.	35	2 ms	35 to 1000	Yes

Pn No.	Parameter name	Setting	Explanation	Default setting	Unit	Setting range	Power OFF→ON
6E	Emergency Stop Torque		Set the torque limit for the following cases. ♦Drive prohibit deceleration with the Stop Selection for Drive Prohibition Input (Pn66) set to 2. ♦Deceleration with the Stop Selection with Main Power OFF (Pn67) set to 8 or 9. ♦Deceleration with the Stop Selection with Servo OFF (Pn69) set to 8 or 9.	0	%	0 to 500	---
6F	Reserved	(Do not change setting.)		---	---	---	---
70	Deviation Counter Overflow Level		Set the deviation counter overflow level.	100	× 256 pulses	0 to 32767	---
71	Speed Command/Torque Command Input Overflow Level Setting		Set the overflow level for Speed Command Input (REF) or Torque Command Input (TREF) using voltage after offset adjustment.	0	0.1 V	0 to 100	---
72	Overload Detection Level Setting		Set the overload detection level.	0	%	0 to 115	---
73	Overspeed Detection Level Setting		Set the overspeed detection level.	0	r/min	0 to 20000	---
78	Reserved	(Do not change setting.)		---	---	---	---
79	Reserved	(Do not change setting.)		---	---	---	---
7A	Reserved	(Do not change setting.)		---	---	---	---
7B	Reserved	(Do not change setting.)		---	---	---	---
7C	Reserved	(Do not change setting.)		---	---	---	---
7D	Reserved	(Do not change setting.)		---	---	---	---
7E	Reserved	(Do not change setting.)		---	---	---	---
7F	Reserved	(Do not change setting.)		---	---	---	---

## Parameters Details

- This section provides an explanation for all parameters.  
Be sure to fully understand the meanings of parameters before making changes to the parameter settings.  
Do not change the parameters marked “Reserved”.  
Do not change the settings marked “Reserved”.

### ■ Function Selection Parameters (Pn00 to Pn0F)

<b>Pn00</b>	Unit No. Setting						All modes
Setting range	0 to 15	Unit	---	Default setting	1	Power OFF→ON	Yes

- If communications with a computer or other host controller are used by multiple Units via RS-232 or RS-485, it is necessary to identify which Unit the host is accessing. With this parameter, the unit number can be confirmed using alphanumeric characters.
- The unit number is determined by the unit number switch setting on the front panel when the power supply is turned ON. This number is the unit number when using serial communications.
- The setting of this parameter has no effect on Servomotor operation.
- The setting of this parameter can be changed only by using the unit number switch on the front panel.

<b>Pn01</b>	Default Display						<span style="border: 1px solid black; padding: 2px;">All modes</span>
Setting range	0 to 17	Unit	---	Default setting	1	Power OFF→ON	Yes

### Explanation of Settings

Setting	Explanation
0	Position deviation
1	Servomotor rotation speed
2	Torque output
3	Control mode
4	I/O signal status
5	Alarm code and history
6	Software version
7	Warning display
8	Regeneration load ratio
9	Overload load ratio
10	Inertia ratio
11	Total feedback pulses
12	Total command pulses
13	Reserved
14	Reserved
15	Automatic Servomotor recognition display
16	Analog input value
17	Reason for no rotation

- Select the data to be displayed on the 7-segment display on the front panel after the power supply is turned ON.
- For information on the display, refer to *6-4 Setting the Mode* on page 6-7.

<b>Pn02</b>	Control Mode Selection					All modes	
Setting range	0 to 6	Unit	---	Default setting	0	Power OFF→ON	Yes

**Explanation of Settings**

Setting	Explanation
0	Position Control Mode (pulse-string command)
1	Speed Control Mode (analog command)
2	Torque Control Mode (analog command)
3	Mode 1: Position Control Mode, Mode 2: Speed Control Mode
4	Mode 1: Position Control Mode, Mode 2: Torque Control Mode
5	Mode 1: Speed Control Mode, Mode 2: Torque Control Mode
6	Reserved

- Use this parameter to set the control mode.
- If composite modes are set (settings 3 to 5), Mode 1 or Mode 2 can be selected using the Control Mode Switch Input (TVSEL).
  - Open the Control Mode Switch Input to select Mode 1.
  - Close the Control Mode Switch Input to select Mode 2.
- Do not input a command within 10 ms before or after switching.

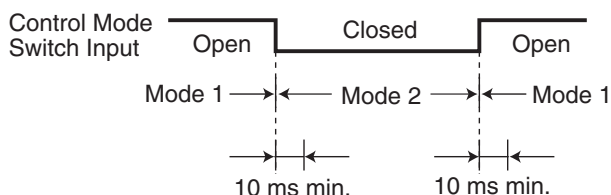

<b>Pn03</b>	Torque Limit Selection					Position Speed	
Setting range	0 to 3	Unit	---	Default setting	1	Power OFF→ON	---

**Explanation of Settings**

Setting	Explanation
0	Use PCL (CN1 pin 16) as the limit value for forward operation and NCL (CN1 pin 18) as the limit value for reverse operation.
1	Use Pn5E as the limit value for forward and reverse operation.
2	Use Pn5E as the limit value for forward operation and Pn5F as the limit value for reverse operation.
3	Use Pn5E as the value when the GSEL/TLSEL input is open and use Pn5F as the value when the GSEL/TLSEL input is closed.

- Use this parameter to set the torque limit method for forward and reverse operation.
- If this parameter is set to 0, the torque limit input for forward and reverse operation will be limited by the No.1 Torque Limit (Pn5E).
- When using torque control, the No.1 Torque Limit (Pn5E) will be the limit value for forward and reverse operation regardless of the setting of this parameter.

<b>Pn04</b>	Drive Prohibit Input Selection						All modes
Setting range	0 to 2	Unit	---	Default setting	1	Power OFF→ON	Yes

### Explanation of Settings

Setting	Explanation
0	Forward Drive Prohibit Input and Reverse Drive Prohibit Input enabled.
1	Forward Drive Prohibit Input and Reverse Drive Prohibit Input disabled.
2	Forward Drive Prohibit Input and Reverse Drive Prohibit Input enabled.

- Install limit switches at both ends of the axis to prohibit the Servomotor from traveling in the direction specified by the switch. This can be used to prevent the workpiece from traveling too far and thus prevent damage to the machine.
- Operation will be as follows if 0 is set.
  - Connection between Forward Drive Prohibit Input (POT: CN1 pin 9) and COM closed: Forward limit switch not operating and status normal.
  - Connection between Forward Drive Prohibit Input (POT: CN1 pin 9) and COM open: Forward drive prohibited and reverse drive permitted.
  - Connection between Reverse Drive Prohibit Input (NOT: CN1 pin 8) and COM closed: Reverse limit switch not operating and status normal.
  - Connection between Reverse Drive Prohibit Input (NOT: CN1 pin 8) and COM open: Reverse drive prohibited and forward drive permitted.
- If this parameter is set to 0, the Servomotor will decelerate and stop according to the sequence set in the Stop Selection for Drive Prohibition Input (Pn66). For details, refer to the explanation for *Stop Selection for Drive Prohibition Input (Pn66)* on page 5-88.
- If this parameter is set to 0 and the forward and reverse prohibit inputs are both open, an error will be detected in the Servo Drive, and a drive prohibit input error (alarm code 38) will occur.
- If this parameter is set to 2, a drive prohibit input error (alarm code 38) will occur when the connection between either the forward or reverse prohibit input and COM is open.
- If a limit switch above the workpiece is turned OFF when using a vertical axis, the upward torque will be eliminated, and there may be repeated vertical movement of the workpiece. If this occurs, set the Stop Selection for Drive Prohibition Input (Pn66) to 2 or limit operation using the host controller rather than using this parameter.

### Alarm Reset

Set the parameter to 0 for executing the alarm reset from the host controller and operating POT and NOT inputs in the opposite direction when either POT or NOT is OPEN.

When the set value is 2, manually change the setting of POT or NOT input to close it and execute the alarm reset to clear the alarm.

<b>Pn05</b>	Command Speed Selection						Speed
Setting range	0 to 3	Unit	---	Default setting	0	Power OFF→ON	---

### Explanation of Settings

Setting	Explanation
0	Speed Command Input (REF: CN1 pin 14)
1	No. 1 Internally Set Speed to No. 4 Internally Set Speed (Pn53 to Pn56)
2	No. 1 Internally Set Speed to No. 3 Internally Set Speed (Pn53 to Pn55) and Speed Command Input (REF)
3	No. 1 Internally Set Speed to No. 8 Internally Set Speed (Pn53 to Pn56 and Pn74 to Pn77)

- Use this parameter to select the speed command when using speed control. The Servo Drive has internally set speeds that can be used to easily achieve speed control by using contact inputs.
- For details on internally set speeds, refer to *5-3 Internally Set Speed Control* on page 5-5.

<b>Pn06</b>	Zero Speed Designation/Speed Command Direction Switch					<input type="checkbox"/> Speed	<input type="checkbox"/> Torque
Setting range	0 to 2	Unit	---	Default setting	0	Power OFF→ON	---

**Explanation of Settings**

Setting	Explanation
0	The zero-speed designation input will be ignored, and a zero-speed designation will not be detected.
1	The zero-speed designation input will be enabled, and the speed command will be assumed to be zero when the connection between the input and common is open.
2	Speed mode: Use as the speed command sign. The rotation direction is forward when the connection between the input and common is open and reverse when the connection between the input and common is closed. Torque mode: The zero-speed designation input will be ignored, and a zero-speed designation will not be detected.

- Use this parameter to set the function of the Zero-speed Designation Input (VZERO: CN1 pin 26).

<b>Pn07</b>	SP Selection					<input type="checkbox"/> All modes	
Setting range	0 to 9	Unit	---	Default setting	3	Power OFF→ON	---

**Explanation of Settings**

Setting	Explanation
0	Actual Servomotor speed: 6 V/47 r/min
1	Actual Servomotor speed: 6 V/188 r/min
2	Actual Servomotor speed: 6 V/750 r/min
3	Actual Servomotor speed: 6 V/3000 r/min
4	Actual Servomotor speed: 1.5 V/3000 r/min
5	Command speed: 6 V/47 r/min
6	Command speed: 6 V/188 r/min
7	Command speed: 6 V/750 r/min
8	Command speed: 6 V/3000 r/min
9	Command speed: 1.5 V/3000 r/min



<b>Pn08</b>	IM Selection						All modes	
Setting range	0 to 12	Unit	---	Default setting	0	Power OFF→ON	---	

### Explanation of Settings

Setting	Explanation
0	Torque command: 3 V/rated (100%) torque
1	Position deviation: 3 V/31 pulses
2	Position deviation: 3 V/125 pulses
3	Position deviation: 3 V/500 pulses
4	Position deviation: 3 V/2000 pulses
5	Position deviation: 3 V/8000 pulses
6	Reserved
7	Reserved
8	Reserved
9	Reserved
10	Reserved
11	Torque command: 3 V/200% torque
12	Torque command: 3 V/400% torque

<b>Pn09</b>	General-purpose Output 2 Selection						All modes	
Setting range	0 to 8	Unit	---	Default setting	0	Power OFF→ON	---	

### Explanation of Settings

Setting	Explanation
0	Output during torque limit
1	Zero speed detection output
2	Warning output for over regeneration, overload, absolute encoder battery, or fan lock
3	Over regeneration warning output
4	Overload warning output
5	Absolute encoder battery warning output
6	Fan lock warning output
7	Reserved
8	Speed conformity output

- Use this parameter to assign the function of General-purpose Output 2 (OUTM2: CN1 pin 40).

<b>Pn0A</b>	General-purpose Output 1 Selection						<b>All modes</b>
Setting range	0 to 8	Unit	---	Default setting	1	Power OFF→ON	---

### Explanation of Settings

Setting	Explanation
0	Output during torque limit
1	Zero speed detection output
2	Warning output for over regeneration, overload, absolute encoder battery, or fan lock
3	Over regeneration warning output
4	Overload warning output
5	Absolute encoder battery warning output
6	Fan lock warning output
7	Reserved
8	Speed conformity output

- Use this parameter to assign the function of General-purpose Output 1 (OUTM1: CN1 pin 12).

<b>Pn0B</b>	Operation Switch When Using Absolute Encoder						<b>All modes</b>
Setting range	0 to 2	Unit	---	Default setting	0	Power OFF→ON	Yes

### Explanation of Settings

Setting	Explanation
0	Use as absolute encoder.
1	Use as incremental encoder.
2	Use as absolute encoder but ignore multi-turn counter overflow.

- Use this parameter to set the operating method for the 17-bit absolute encoder.
- The setting of this parameter is disabled if a 5-core 2,500-pulse/revolution incremental encoder is used.

<b>Pn0C</b>	RS-232 Baud Rate Setting						All modes	
Setting range	0 to 5	Unit	---	Default setting	2	Power OFF→ON	Yes	

### Explanation of Settings

Setting	Explanation
0	2,400 bps
1	4,800 bps
2	9,600 bps
3	19,200 bps
4	38,400 bps
5	57,600 bps

- Use this parameter to select the baud rate for RS-232 communications.
- Baud rate error:  $\pm 0.5\%$ .

<b>Pn0D</b>	RS-485 Baud Rate Setting						All modes	
Setting range	0 to 5	Unit	---	Default setting	2	Power OFF→ON	Yes	

### Explanation of Settings

Setting	Explanation
0	2,400 bps
1	4,800 bps
2	9,600 bps
3	19,200 bps
4	38,400 bps
5	57,600 bps

- Use this parameter to select the baud rate for RS-485 communications.
- Baud rate error:  $\pm 0.5\%$ .

<b>Pn0E</b>	Front Key Protection Setting						All modes	
Setting range	0 to 1	Unit	---	Default setting	0	Power OFF→ON	Yes	

### Explanation of Settings

Setting	Explanation
0	All enabled
1	Limited to Monitor Mode

- Front panel key operations can be limited to Monitor Mode. This function can be used to prevent unintended changes to parameters because of incorrect key operations.
- Even if this parameter is set to 1, parameters can be changed by using communications.
- Use communications to return this parameter to 0.

<b>Pn0F</b>	Reserved						
Setting range	---	Unit	---	Default setting	---	Power OFF→ON	---

■ Gain Parameters (Pn10 to Pn3D)

<b>Pn10</b>	Position Loop Gain						<span style="border: 1px solid black; padding: 2px;">Position</span>
Setting range	0 to 3000	Unit	1/s	Default setting	40	Power OFF→ON	---

- Use this parameter to adjust the position loop response to suit the mechanical rigidity.
  - The responsiveness of the servo system is determined by the position loop gain. Servo systems with a high loop gain have a high responsiveness and fast positioning. To increase the position loop gain, you must improve mechanical rigidity and increase the specific oscillation frequency. This should be 50 to 70 (1/s) for ordinary machine tools, 30 to 50 (1/s) for general-use and assembly machines, and 10 to 30 (1/s) for industrial robots. The default position loop gain is 40 (1/s), so be sure to lower the setting for machines with low rigidity.
  - Increasing the position loop gain in systems with low mechanical rigidity or systems with low specific oscillation frequencies may cause machine resonance, resulting in an overload alarm.
  - If the position loop gain is low, you can shorten the positioning time using feed forward.
  - This parameter is automatically changed by executing realtime autotuning. To set it manually, set the Realtime Autotuning Mode Selection (Pn21) to 0.
- Position loop gain is generally expressed as follows:

$$\text{Position loop gain (Kp)} = \frac{\text{Command pulse frequency (pulses/s)}}{\text{Deviation counter accumulated pulses (pulses)}} \text{ (1/s)}$$

When the position loop gain is changed, the response is as shown in the following diagram.

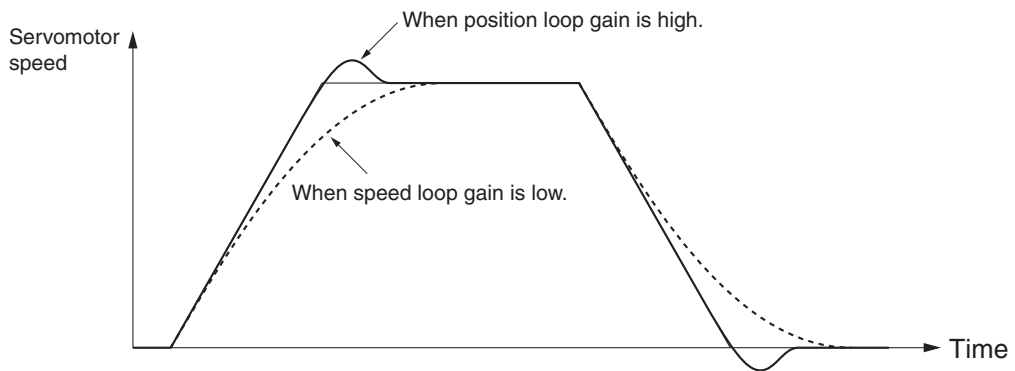

- If the speed loop gain and position loop gain are optimally set, the Servomotor operation for the command will be delayed  $2/Kp$  at acceleration and delayed  $3/Kp$  at deceleration.

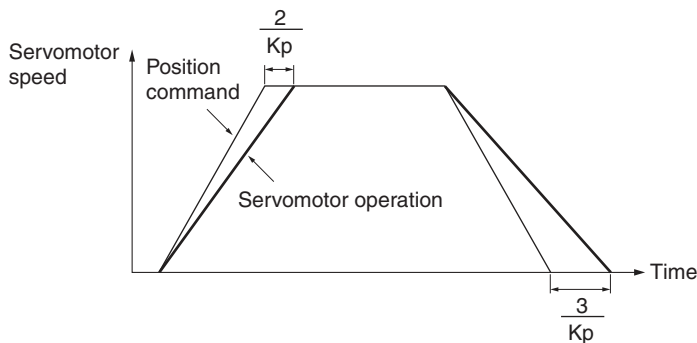

<b>Pn11</b>	Speed Loop Gain						All modes
Setting range	1 to 3500	Unit	Hz	Default setting	50	Power OFF→ON	---

- Use this parameter to determine speed loop responsiveness.
- The setting for the Speed Loop Gain must be increased to increase the Position Loop Gain and improve the responsiveness of the entire servo system. Setting the Speed Loop Gain too high, however, may result in oscillation.
- The setting unit for Pn11 will be Hz if the Inertia Ratio (Pn20) is set correctly.

When the speed loop gain is changed, the response is as shown in the following diagram.

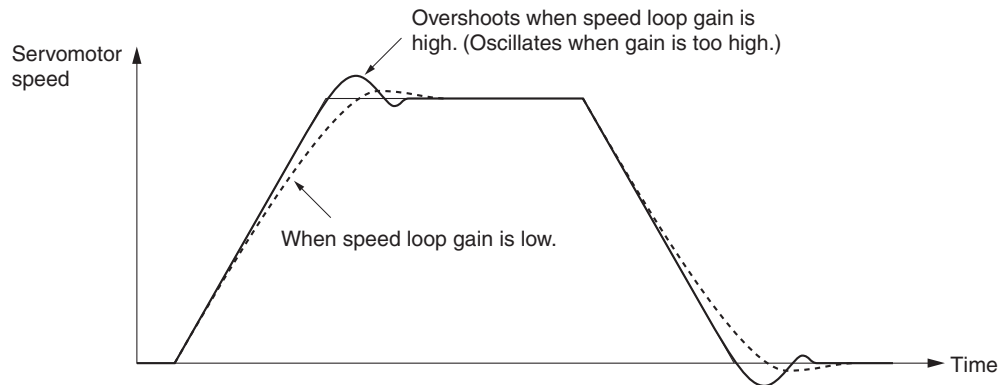

<b>Pn12</b>	Speed Loop Integration Time Constant						All modes
Setting range	1 to 1000	Unit	ms	Default setting	20	Power OFF→ON	---

- Use this parameter to set the speed loop integration time constant.
- The smaller the setting, the faster the deviation will come close to 0 when stopping. If 1000 is set, the integral will be ineffective.

When the speed loop integration time constant is changed, the response is as shown in the following diagram.

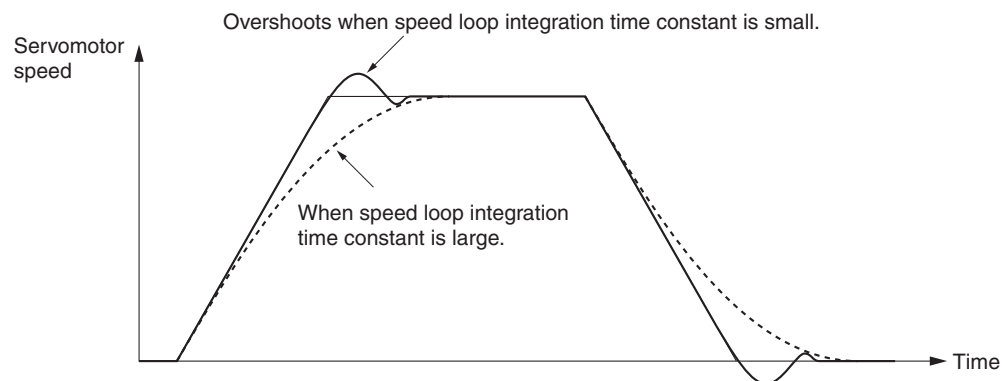

## 5-16 User Parameters

<b>Pn13</b>	Speed Feedback Filter Time Constant						All modes
Setting range	0 to 5	Unit	---	Default setting	0	Power OFF→ON	---

- Use this parameter to set the time constant for the low-pass filter (LPF) after speed detection to one of six value (0 to 5).
- Increasing the setting increases the time constant and decreases the noise generated by the Servomotor. Responsiveness, however, also decreases.
- Normally, use the default setting.

<b>Pn14</b>	Torque Command Filter Time Constant						All modes
Setting range	0 to 2500	Unit	0.01ms	Default setting	80	Power OFF→ON	---

- Use this parameter to set the time constant for the first-order lag filter inserted into the torque command.
- This parameter may be effective in suppressing oscillation due to torsion resonance.

<b>Pn15</b>	Feed-forward Amount						Position
Setting range	-2000 to 2000	Unit	0.10%	Default setting	300	Power OFF→ON	---

- Use this parameter to set the feed-forward amount in Position Control Mode.
- Increasing the setting decreases the position deviation and increases the responsiveness. Overshooting, however, will occur more easily.

<b>Pn16</b>	Feed-forward Command Filter						Position
Setting range	0 to 6400	Unit	0.01ms	Default setting	100	Power OFF→ON	---

- Use this parameter to set the time constant for the first-order lag filter inserted into the feed-forward.
- Setting the Feed-forward Command Filter may improve operation if speed overshooting occurs or the noise during operation is large when the feed forward is set high.

<b>Pn17</b>	Reserved						
Setting range	---	Unit	---	Default setting	---	Power OFF→ON	---

<b>Pn18</b>	Position Loop Gain 2						Position
Setting range	1 to 3000	Unit	1/s	Default setting	20	Power OFF→ON	---

- Use this parameter to set the responsiveness of the position control system for the second position loop.

<b>Pn19</b>	Speed Loop Gain 2						All modes
Setting range	1 to 3500	Unit	Hz	Default setting	80	Power OFF→ON	---

- Use this parameter to set the responsiveness of the second speed loop.

<b>Pn1A</b>	Speed Loop Integration Time Constant 2						All modes	
Setting range	1 to 1000	Unit	ms	Default setting	50	Power OFF→ON	---	

- Use this parameter to set the second speed loop integration time constant.

<b>Pn1B</b>	Speed Feedback Filter Time Constant 2						All modes	
Setting range	0 to 5	Unit	---	Default setting	0	Power OFF→ON	---	

- Use this parameter to set the second speed feedback filter time constant.

<b>Pn1C</b>	Torque Command Filter Time Constant 2						All modes	
Setting range	0 to 2500	Unit	0.01 ms	Default setting	100	Power OFF→ON	---	

- Use this parameter to set the second torque command filter time constant.
- The parameters from Pn18 to Pn1C are the gain and time constants to be selected when gain switching is enabled in the Gain Switching Input Operating Mode Selection (Pn30).
- The gain is switched according to the condition set in the Control Gain Switch 1 Setting (Pn31).
- If the mechanical system inertia changes greatly or if you want to change the responsiveness when the Servomotor is rotating and when it is being stopped, you can achieve the appropriate control by setting the gains and time constants beforehand for each of these conditions, and switch them according to the condition.
- These parameters are automatically changed by executing realtime autotuning. To set them manually, set the Realtime Autotuning Mode Selection (Pn21) to 0.
- Gain switching is enabled only for position control.

<b>Pn1D</b>	Notch Filter 1 Frequency						All modes	
Setting range	100 to 1500	Unit	Hz	Default setting	1500	Power OFF→ON	---	

- Use this parameter to set the frequency of notch filter 1 for resonance suppression.
- The notch filter function will be disabled if this parameter is set to 1500.

<b>Pn1E</b>	Notch Filter 1 Width						All modes	
Setting range	0 to 4	Unit	---	Default setting	2	Power OFF→ON	---	

- Use this parameter to set the width of notch filter 1 for resonance suppression to one of 5 levels.
- Increasing the setting increases the notch width. Normally, use the default setting.

<b>Pn1F</b>	Reserved						
Setting range	---	Unit	---	Default setting	---	Power OFF→ON	---

<b>Pn20</b>	Inertia Ratio						All modes
Setting range	0 to 10000	Unit	%	Default setting	300	Power OFF→ON	---

- Use this parameter to set the load inertia as a percentage of the Servomotor rotor inertia.
- $Pn20 = (\text{Load inertia} \div \text{Rotor inertia}) \times 100\%$
- When normal mode autotuning is executed, the load inertia will be automatically estimated after the specified operation, and this parameter will be updated with the result.
- When realtime autotuning is enabled, the inertia ratio is continuously estimated and saved in EEPROM every 30 min.
- If the inertia ratio is set correctly, the setting unit for the Speed Loop Gain (Pn11) and Speed Loop Gain 2 (Pn19) will be Hz.
- If the Inertia Ratio (Pn20) is set larger than the actual value, the setting for speed loop gain will increase. If the inertia ratio is set smaller than the actual value, the setting for speed loop gain will decrease.

<b>Pn21</b>	Realtime Autotuning Mode Selection						All modes
Setting range	0 to 7	Unit	---	Default setting	0	Power OFF→ON	---

**Explanation of Settings**

Setting	Explanation
0	Realtime autotuning is disabled.
1	Normal mode: There is almost no change.
2	Normal mode: There are gradual changes.
3	Normal mode: There are sudden changes.
4	Vertical axis mode: There is almost no change.
5	Vertical axis mode: There are gradual changes.
6	Vertical axis mode: There are sudden changes.
7	No gain switching: There is almost no change.

- Use this parameter to set the operating mode for realtime autotuning.
- The higher the value that is set (e.g., 3 or 6), the faster the response is for a change in inertia during operation. Operation, however, may be unstable depending on the operating pattern. Normally, set the parameter to 1 or 4.
- Use a setting of 4 to 6 if a vertical axis is used.
- Use setting 7 if vibration is caused by gain switching.

<b>Pn22</b>	Realtime Autotuning Machine Rigidity Selection						All modes
Setting range	0 to F	Unit	---	Default setting	2	Power OFF→ON	---

- Use this parameter to set the machine rigidity to one of 16 levels when realtime autotuning is enabled.

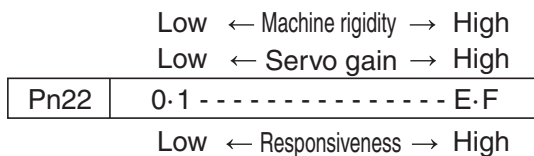

- If the setting is changed suddenly by a large amount, the gain will change rapidly, subjecting the machine to shock. Always start by making small changes in the setting, and gradually increase the setting while monitoring machine operation.



<b>Pn23</b>	Adaptive Filter Selection						Position	Speed
Setting range	0 to 2	Unit	---	Default setting	0	Power OFF→ON	Yes	

**Explanation of Settings**

Setting	Explanation
0	Adaptive filter disabled.
1	Adaptive filter enabled.
2	Hold (The adaptive filter frequency when the setting was changed to 2 will be held.)

- Use this parameter to set the operation of the adaptive filter.
- The Adaptive Filter Table Number Display (Pn2F) will be reset to 0 when the adaptive filter is disabled.
- The adaptive filter is normally disabled in the torque control mode.

<b>Pn24</b>	Vibration Filter Selection						Position
Setting range	0 to 2	Unit	---	Default setting	0	Power OFF→ON	---

**Explanation of Settings**

Setting	Explanation
0	No switching. (Both filter 1 and filter 2 are enabled.)
1	Filter 1 or filter 2 can be selected using vibration filter switching (DFSEL). ♦DFSEL open: Vibration filter 1 (Pn2B and Pn2C) is selected. ♦DFSEL closed: Vibration filter 2 (Pn2D and Pn2E) is selected.
2	Switching with position command direction. ♦Forward: Vibration filter 1 (Pn2B and Pn2C) is selected. ♦Reverse: Vibration filter 2 (Pn2D and Pn2E) is selected.

<b>Pn25</b>	Autotuning Operation Setting						All modes
Setting range	0 to 7	Unit	---	Default setting	0	Power OFF→ON	---

**Explanation of Settings**

Setting	Rotation direction	Number of rotations
0	Forward to reverse	Two rotations
1	Reverse to forward	
2	Forward to forward	
3	Reverse to reverse	
4	Forward to reverse	One rotation
5	Reverse to forward	
6	Forward to forward	
7	Reverse to reverse	

- Set the operating pattern for normal mode autotuning.

<b>Pn26</b>	Overrun Limit Setting						Position
Setting range	0 to 1000	Unit	0.1 revolution	Default setting	10	Power OFF→ON	---

- Use this parameter to set the Servomotor's allowable operating range for the position command input range.
- An overrun limit error (alarm code 34) will occur if the setting is exceeded.
- The function will be disabled if the setting is 0.
- For details, refer to *Overrun Limit* on page 5-19.

<b>Pn27</b>	Instantaneous Speed Observer Setting						Position	Speed
Setting range	0 to 1	Unit	---	Default setting	0	Power OFF→ON	---	

### Explanation of Settings

Setting	Explanation
0	Disabled
1	Enabled

- The instantaneous speed observer can both increase the responsiveness and reduce vibration at stopping by improving the speed detection accuracy for devices with high rigidity.
- The Inertia Ratio (Pn20) must be set correctly.
- The Instantaneous Speed Observer Setting (Pn27) will be 0 (disabled) if the Realtime Autotuning Mode Selection (Pn21) is not set to 0 (enabled).

<b>Pn28</b>	Notch Filter 2 Frequency						All modes
Setting range	100 to 1500	Unit	Hz	Default setting	1500	Power OFF→ON	---

- Use this parameter to set the notch frequency of notch filter 2 for resonance suppression.
- The notch filter will be disabled if the setting is 1500.

<b>Pn29</b>	Notch Filter 2 Width						All modes
Setting range	0 to 4	Unit	---	Default setting	2	Power OFF→ON	---

- Use this parameter to set the notch width of notch filter 2 for resonance suppression.
- Increasing the setting will increase the notch width. Normally, use the default setting.

<b>Pn2A</b>	Notch Filter 2 Depth						All modes
Setting range	0 to 99	Unit	---	Default setting	0	Power OFF→ON	---

- Use this parameter to set the notch depth of notch filter 2 for resonance suppression.
- Increasing the setting will decrease the notch depth and the phase lag.

<b>Pn2B</b>	Vibration Frequency 1						Position
Setting range	0 to 2000	Unit	0.1 Hz	Default setting	0	Power OFF→ON	---

- Use this parameter to set vibration frequency 1 for damping control to suppress vibration at the end of the load.
- Measure the frequency at the end of the load and make the setting in units of 0.1 Hz.
- Setting frequency: 10.0 to 200.0 Hz. The function will be disabled if the setting is 0 to 9.9 Hz.
- Refer to *Damping Control* on page 7-35 for more information.

<b>Pn2C</b>	Vibration Filter 1 Setting						Position
Setting range	-200 to 2000	Unit	0.1 Hz	Default setting	0	Power OFF→ON	---

- First set the Vibration Frequency 1 (Pn2B). Then reduce the setting of Pn2C if torque saturation occurs or increase the setting of Pn2C to increase operation speed. Normally, use a setting of 0.
- Other than the setting range, the following restriction also applies:  $10.0 \text{ Hz} - \text{Pn2B} \leq \text{Pn2C} \leq \text{Pn2B}$ .
- Refer to *Damping Control* on page 7-35 for more information.

<b>Pn2D</b>	Vibration Frequency 2						Position
Setting range	0 to 2000	Unit	0.1 Hz	Default setting	0	Power OFF→ON	---

- Use this parameter to set the vibration frequency 2 for damping control to suppress vibration at the end of the load.
- Measure the frequency at the end of the load and make the setting in units of 0.1 Hz.
- Setting frequency: 10.0 to 200.0 Hz. The function will be disabled if the setting is 0 to 9.9 Hz.
- Refer to *Damping Control* on page 7-35 for more information.

<b>Pn2E</b>	Vibration Filter 2 Setting						Position
Setting range	-200 to 2000	Unit	0.1 Hz	Default setting	0	Power OFF→ON	---

- First set the Vibration Frequency 2 (Pn2D). Then reduce the setting of Pn2E if torque saturation occurs or increase the setting of Pn2E to increase operation speed. Normally, use a setting of 0.
- Other than the setting range, the following restriction also applies:  $10.0 \text{ Hz} - \text{Pn2D} \leq \text{Pn2E} \leq \text{Pn2D}$
- Refer to *Damping Control* on page 7-35 for more information.

<b>Pn2F</b>	Adaptive Filter Table Number Display					<b>Position</b>	<b>Speed</b>
Setting range	0 to 64	Unit	---	Default setting	0	Power OFF→ON	---

**Explanation of Settings**

Displayed value	Notch Filter 1 Frequency (Hz)	Displayed value	Notch Filter 1 Frequency (Hz)	Displayed value	Notch Filter 1 Frequency (Hz)
0	Disabled	22	766	44	326
1	Disabled	23	737	45	314
2	Disabled	24	709	46	302
3	Disabled	25	682	47	290
4	Disabled	26	656	48	279
5	1482	27	631	49	269 (Disabled when Pn22 ≥ F)
6	1426	28	607	50	258 (Disabled when Pn22 ≥ F)
7	1372	29	584	51	248 (Disabled when Pn22 ≥ F)
8	1319	30	562	52	239 (Disabled when Pn22 ≥ F)
9	1269	31	540	53	230 (Disabled when Pn22 ≥ F)
10	1221	32	520	54	221 (Disabled when Pn22 ≥ E)
11	1174	33	500	55	213 (Disabled when Pn22 ≥ E)
12	1130	34	481	56	205 (Disabled when Pn22 ≥ E)
13	1087	35	462	57	197 (Disabled when Pn22 ≥ E)
14	1045	36	445	58	189 (Disabled when Pn22 ≥ E)
15	1005	37	428	59	182 (Disabled when Pn22 ≥ D)
16	967	38	412	60	Disabled
17	930	39	396	61	Disabled
18	895	40	381	62	Disabled
19	861	41	366	63	Disabled
20	828	42	352	64	Disabled
21	796	43	339		

- This parameter displays the table entry number corresponding to the frequency of the adaptive filter.
- This parameter is set automatically and cannot be changed if the adaptive filter is enabled (if the Adaptive Filter Selection (Pn23) is not 0).
- When the adaptive filter is enabled, data will be saved in EEPROM every 30 min. If the adaptive filter is enabled the next time the power supply is turned ON, adaptive operation will start with the data saved in EEPROM as the default value.
- To clear this parameter and reset the adaptive operation, disable the adaptive filter by setting the Adaptive Filter Selection (Pn23) to 0, and then enable it again.

<b>Pn30</b>	Gain Switching Input Operating Mode Selection						All modes
Setting range	0 or 1	Unit	---	Default setting	1	Power OFF→ON	---

### Explanation of Settings

Setting	Explanation
0	Gain 1 (PI/P switching enabled)
1	Gain 1/gain 2 switching enabled

- Use this parameter to select whether to switch between PI and P operation or to switch between gain 1 and gain 2 in Speed Control Mode.
- PI/P operation switching is performed using gain switching (GSEL: CN1 pin 27). PI is not changed, however, if the Torque Limit Selection (Pn03) is set to 3.

Gain input	Speed loop operation
COM open	PI operation
COM connection	P operation

- For information on conditions for switching between gain 1 and gain 2, refer to *Gain Switching Function* on page 7-26.

<b>Pn31</b>	Control Gain Switch 1 Setting						All modes
Setting range	0 to 10	Unit	---	Default setting	0	Power OFF→ON	---

**Explanation of Settings**

Position Control Mode

(○: Enabled, ×: Disabled)

Setting	Explanation			
	Gain switching conditions	Gain Switch 1 Time (Pn32) <sup>*1</sup>	Gain Switch 1 Level Setting (Pn33)	Gain Switch 1 Hysteresis Setting (Pn34) <sup>*2</sup>
0	Always gain 1 (Pn10 to Pn14)	×	×	×
1	Always gain 2 (Pn18 to Pn1C)	×	×	×
2	Switching using Gain Switch Input (GSEL) for CN1 pin 27	×	×	×
3	Amount of change in torque command (Figure A)	○	○ <sup>*3</sup> (× 0.05%)	○ <sup>*3</sup> (× 0.05%)
4	Always gain 1 (Pn10 to Pn14)	×	×	×
5	Command speed (Figure B)	○	○ (r/min)	○ (r/min)
6	Amount of position deviation (Figure C)	○	○ <sup>*4</sup> (Pulse)	○ <sup>*4</sup> (Pulse)
7	Command pulses received (Figure D)	○	×	×
8	Positioning Completed Signal (INP) OFF (Figure E)	○	×	×
9	Actual Servomotor speed (Figure B)	○	○ (r/min)	○ (r/min)
10	Combination of command pulse input and speed (Figure F)	○	○ <sup>*5</sup> (r/min)	○ <sup>*5</sup> (r/min)

Speed Control Mode

Setting	Explanation			
	Gain switching conditions	Gain Switch Time (Pn32, 37) <sup>*1</sup>	Gain Switch Level Setting (Pn33, 38)	Gain Switch Hysteresis Setting (Pn34, 39) <sup>*2</sup>
0	Always gain 1 (Pn10 to Pn14)	×	×	×
1	Always gain 2 (Pn18 to Pn1C)	×	×	×
2	Switching using Gain Switch Input (GSEL) for CN1 pin 27	×	×	×
3	Amount of change in torque command (Figure A)	○	○ <sup>*3</sup> (0.05%/166 μs)	○ <sup>*3</sup> (0.05%/166 μs)
4	Amount of change in speed command (Figure B)	○	○ <sup>*5</sup> (10 r/min/s)	○ <sup>*5</sup> (10 r/min/s)
5	Command speed (Figure C)	○	○ (r/min)	○ (r/min)

Torque Control Mode

Setting	Explanation			
	Gain switching conditions	Gain Switch Time (Pn32, 37) <sup>*1</sup>	Gain Switch Level Setting (Pn33, 38)	Gain Switch Hysteresis Setting (Pn34, 39) <sup>*2</sup>
0	Always gain 1 (Pn10 to Pn14)	×	×	×
1	Always gain 2 (Pn18 to Pn1C)	×	×	×
2	Switching using Gain Switch Input (GSEL) for CN1 pin 27	×	×	×
3	Amount of change in torque command (Figure A)	○	○ <sup>*3</sup> (0.05%/166 μs)	○ <sup>*3</sup> (0.05%/166 μs)

- Use this parameter to select the conditions for switching between gain 1 and gain 2 when the Gain Switching Input Operation Mode Selection (Pn30) is set to 1.
- The gain is always gain 1 regardless of the gain input if the Control Gain Switch 1 Setting (Pn31) is 2 and the Torque Limit Selection (Pn03) is 3.
- If the Control Mode Setting (Pn02) is set to a composite mode (3, 4, or 5), the setting of this parameter is valid when the first control mode is used.

\*1. The Gain Switch 1 Time (Pn32) is used when returning from gain 2 to gain 1.

\*2. The Gain Switch 1 Hysteresis Setting (Pn34) is defined as shown in the following figure.

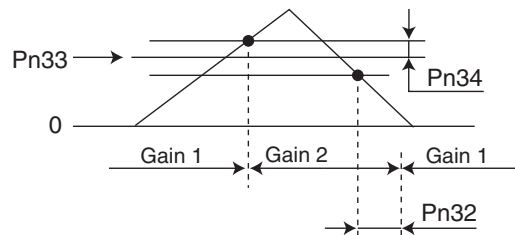

\*3. The amount of change is the value within 166 μs.

Example: When the condition is a 10% change in torque in 166 μs, the set value is 200.

\*4. This is the encoder resolution.

\*5. The meanings of the Gain Switch Time, Gain Switch Level Setting, and Gain Switch Hysteresis Setting are different from normal if this parameter is set to 10. (Refer to Figure F.)

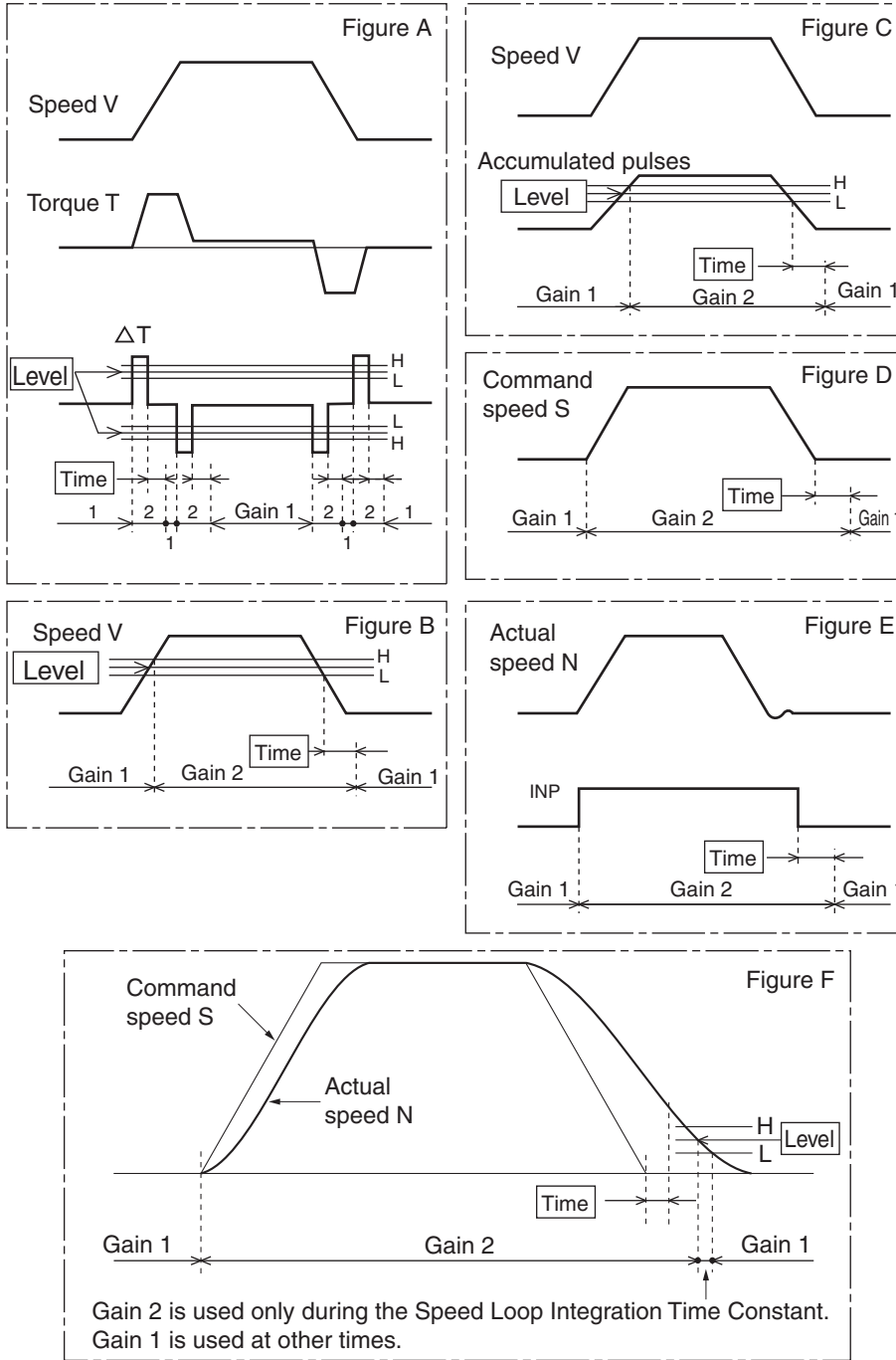

<b>Pn32</b>	Gain Switch 1 Time	<b>All modes</b>					
Setting range	0 to 10000	Unit	× 166 μs	Default setting	30	Power OFF→ON	---

- For Position Control Mode, use this parameter to set the delay time when returning from gain 2 to gain 1 if the Control Gain Switch 1 Setting (Pn31) is 3 or 5 to 10.
- For Speed Control Mode, use this parameter to set the delay time when returning from gain 2 to gain 1 if the Control Gain Switch 1 Setting (Pn31) is 3 to 5.
- For Torque Control Mode, use this parameter to set the delay time when returning from gain 2 to gain 1 if the Control Gain Switch 1 Setting (Pn31) is 3.



<b>Pn33</b>	Gain Switch 1 Level Setting						All modes
Setting range	0 to 20000	Unit	---	Default setting	600	Power OFF→ON	---

- For Position Control Mode, use this parameter to set the judgment level for switching between gain 1 and gain 2. If the Control Gain Switch 1 Setting (Pn31) is set to 3, 5, 6, 9, or 10, Pn33 is enabled. The unit depends on the Control Gain Switch 1 Setting (Pn31).
- For Speed Control Mode, use this parameter to set the judgment level for switching between gain 1 and gain 2. If the Control Gain Switch 1 Setting (Pn31) is set to 3 to 5, Pn33 is enabled. The unit depends on the Control Gain Switch 1 Setting (Pn31).
- For Torque Control Mode, use this parameter to set the judgment level for switching between gain 1 and gain 2. If the Control Gain Switch 1 Setting (Pn31) is set to 3, Pn33 is enabled. The unit depends on the Control Gain Switch 1 Setting (Pn31).

<b>Pn34</b>	Gain Switch 1 Hysteresis Setting						All modes
Setting range	0 to 20000	Unit	---	Default setting	50	Power OFF→ON	---

- Use this parameter to set the hysteresis width for the judgment level set in the Gain Switch 1 Level Setting (Pn33). The unit depends on the Control Gain Switch 1 Setting (Pn31). The following shows the definitions for the Gain Switch 1 Time (Pn32), Gain Switch 1 Level Setting (Pn33), and Gain Switch 1 Hysteresis Setting (Pn34).

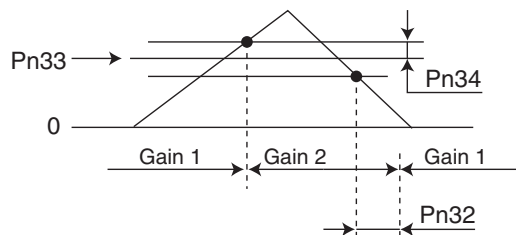

- The settings for the Gain Switch 1 Level Setting (Pn33) and the Gain Switch 1 Hysteresis Setting (Pn34) are effective as absolute values (positive/negative).

<b>Pn35</b>	Position Loop Gain Switching Time						Position
Setting range	0 to 10000	Unit	$\times 166 \mu\text{s}$	Default setting	20	Power OFF→ON	---

- When switching between gain 1 and gain 2 is enabled, set the phased switching time only for position loop gain at gain switching.

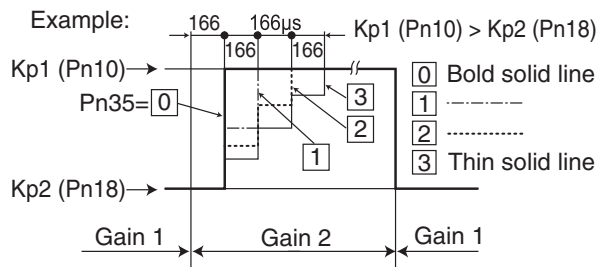

<b>Pn36</b>	Control Gain Switch 2 Setting					Speed	Torque
Setting range	0 to 5	Unit	---	Default setting	0	Power OFF→ON	---

**Explanation of Settings**

Setting	Explanation
0	Always gain 1
1	Always gain 2
2	Gain 2 is selected when the Gain Switching Input (GSEL: CN1 pin 27) is ON. (The Gain Switching Input Operating Mode Selection (Pn30) must be set to 1.)
3	Gain 2 is selected as the amount of change in the torque command increases.
4	Gain 2 is selected as the amount of change in speed command (i.e., acceleration) increases.
5	Gain 2 is selected as the command speed increases.

- If the Control Mode Setting (Pn02) is set to a composite mode (3, 4, or 5), the setting of this parameter is valid when the second control mode is used.
- Use this parameter to select the conditions for switching between gain 1 and gain 2 if the second control mode is used when the Gain Switching Input Operating Mode Selection (Pn30) is set to 1.
- If 2 is selected, the Control Gain Switch 1 Setting (Pn31) is set to 2 and the Torque Limit Selection (Pn03) is set to 3, the gain is always gain 1 regardless of the gain input.
- For information on switching levels and timing, refer to *Gain Switching Function* on page 7-26.

<b>Pn37</b>	Gain Switch 2 Time					Speed	Torque
Setting range	0 to 10000	Unit	× 166 μs	Default setting	30	Power OFF→ON	---

- Use this parameter to set the delay time when returning from gain 2 to gain 1 if the Control Gain Switch 2 Setting (Pn36) is 3 to 5.

<b>Pn38</b>	Gain Switch 2 Level Setting					Speed	Torque
Setting range	0 to 20000	Unit	---	Default setting	0	Power OFF→ON	---

- Use this parameter to set the judgment level for switching between gain 1 and gain 2 when the Control Gain Switch 2 Setting (Pn36) is set to 3 to 5. The unit depends on the setting for the Control Gain Switch 2 Setting (Pn36).

<b>Pn39</b>	Gain Switch 2 Hysteresis Setting					Speed	Torque
Setting range	0 to 20000	Unit	---	Default setting	0	Power OFF→ON	---

- Use this parameter to set the hysteresis width for the judgment level set in the Gain Switch 2 Level setting (Pn38). The unit depends on the Control Gain Switch 2 Setting (Pn36). The following shows the definitions for the Gain Switch 2 Time (Pn37), Gain Switch 2 Level Setting (Pn38), and Gain Switch 2 Hysteresis Setting (Pn39).

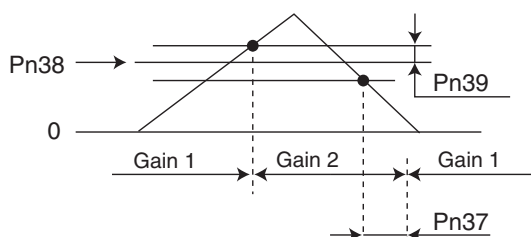

- The settings for the Gain Switch 2 Level Setting (Pn38) and the Gain Switch 2 Hysteresis Setting

(Pn39) are effective as absolute values (positive/negative).

<b>Pn3D</b>	Jog Speed						All modes	
Setting range	0 to 500	Unit	r/min	Default setting	200	Power OFF→ON	---	

- Use this parameter to set the speed for jog operation.
- Before use, refer to *Jog Operation* on page 6-24.

## ■ Position Control Parameters (Pn40 to Pn4E)

<b>Pn40</b>	Command Pulse Input Selection						Position	
Setting range	0 or 1	Unit	---	Default setting	0	Power OFF→ON	Yes	

### Explanation of Settings

Setting	Explanation
0	Photocoupler input (+PULS: CN1 pin 3, -PULS: CN1 pin 4, +SIGN: CN1 pin 5, -SIGN: CN1 pin 6)
1	Line driver input (+CWLD: CN1 pin 44, -CWLD: CN1 pin 45, +CCWLD: CN1 pin 46, -CCWLD: CN1 pin 47)

- Use this parameter to select whether to use photocoupler or line-driver input for the command pulse input.
- When using a Servo Relay Unit cable, set to 0 (photocoupler input).

<b>Pn41</b>	Command Pulse Rotation Direction Switch						Position	
Setting range	0 or 1	Unit	---	Default setting	0	Power OFF→ON	Yes	

### Explanation of Settings

Setting	Explanation
0	The Servomotor rotates in the direction specified by the command pulse.
1	The Servomotor rotates in the opposite direction from the direction specified by the command pulse.

- Use this parameter to set the Servomotor rotation direction used for the command pulse input.

<b>Pn42</b>	Command Pulse Mode						<b>Position</b>
Setting range	0 to 3	Unit	---	Default setting	1	Power OFF→ON	Yes

**Explanation of Settings**

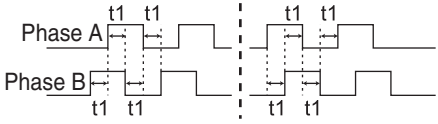
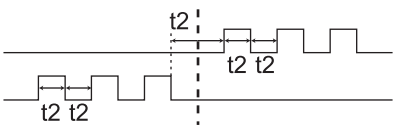
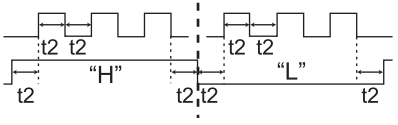
Setting	Command pulse mode	Servomotor forward command	Servomotor reverse command
0 or 2	90° phase difference (phases A and B) signal inputs	 <p>Line driver: <math>t1 \geq 2 \mu s</math> Open collector: <math>t1 \geq 5 \mu s</math></p>	
1	Reverse pulse and forward pulse inputs	 <p>Line driver: <math>t2 \geq 1 \mu s</math> Open collector: <math>t2 \geq 2.5 \mu s</math></p>	
3	Feed pulse input and forward/reverse signal input	 <p>Line driver: <math>t2 \geq 1 \mu s</math> Open collector: <math>t2 \geq 2.5 \mu s</math></p>	

- Use this parameter to set the form of the pulse inputs sent as commands to the Servo Drive from the position controller.

<b>Pn43</b>	Command Pulse Prohibited Input						<b>Position</b>
Setting range	0 or 1	Unit	---	Default setting	1	Power OFF→ON	---

**Explanation of Settings**

Setting	Explanation
0	Enabled
1	Disabled

- Use this parameter to enable or disable the Pulse Prohibit Input (IPG: CN1 pin 33).
- Command pulse inputs will be prohibited when the connection between the IPG input and COM is open.
- Set this parameter to 1 when the IPG input is not used. This will eliminate the necessity to externally connect the IPG input (CN1 pin 33) and COM (CN1 pin 41).

<b>Pn44</b>	Encoder Divider Numerator Setting						All modes
Setting range	0 to 32767	Unit	---	Default setting	2500	Power OFF→ON	Yes

<b>Pn45</b>	Encoder Divider Denominator Setting						All modes
Setting range	0 to 32767	Unit	---	Default setting	0	Power OFF→ON	Yes

- Use this parameter to set the number of encoder pulses output from the pulse outputs (+A: CN1 pin 21, -A: CN1 pin 22, -B: CN1 pin 48, +B: CN1 pin 49)
- If the Encoder Divider Denominator Setting (Pn45) is 0, the number of output pulses for one Servomotor rotation can be set for A and B using the Encoder Divider Numerator Setting (Pn44). The resolution of the pulse output after multiplication by 4 will be as follows:

$$\text{Pulse output resolution per rotation} = \text{Encoder Divider Numerator Setting (Pn44)} \times 4$$

- If the Encoder Divider Denominator Setting (Pn45) is not 0, the pulse output resolution per rotation can be set using the following encoder divider equation.

$$\text{Pulse output resolution per rotation} = \frac{\text{Pn44 (Encoder Divider Numerator Setting)}}{\text{Pn45 (Encoder Divider Denominator Setting)}} \times \text{Encoder resolution}$$

- The encoder resolution for a 17-bit absolute encoder is 131,072 pulses/rotation and a 2,500-pulse/rotation, 5-core incremental encoder is 10,000 pulses/rotation.
- The pulse output resolution per rotation will never exceed the encoder resolution. (If the above settings are used, the pulse output resolution per rotation will be equal to the encoder resolution.)
- One phase-Z signal is output for each rotation of the Servomotor.
- If the value from the above equation is a multiple of 4, phases Z and A are synchronized. In all other cases, the output width of phase Z will coincide with the encoder resolution, so phases A and Z will not be synchronized.

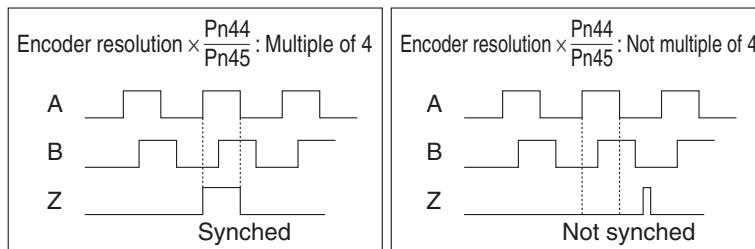

- Refer to 5-7 Encoder Dividing on page 5-15 for more information on the encoder divider.

<b>Pn46</b>	Encoder Output Direction Switch					<b>All modes</b>	
Setting range	0 or 1	Unit	---	Default setting	0	Power OFF→ON	Yes

Setting	Phase	Forward motor operation	Reverse motor operation
---	Phase A		
0	Non-inverted phase B		
1	Inverted phase B		

### Explanation of Settings

Setting	Explanation
0	Phase-B output: Not inverted, Output source: Encoder position
1	Phase-B output: Inverted, Output source: Encoder position

- Use this parameter to set the phase-B logic for pulse output (-B: CN1 pin 48, +B: CN1 pin 49).
- This parameter can be used to invert the output direction of the phase-B pulse to reverse the relation of the phase-B pulse to the phase-A pulse.

<b>Pn48</b>	Electronic Gear Ratio Numerator 1						Position
Setting range	0 to 10000	Unit	---	Default setting	0	Power OFF→ON	---
<b>Pn49</b>	Electronic Gear Ratio Numerator 2						Position
Setting range	0 to 10000	Unit	---	Default setting	0	Power OFF→ON	---
<b>Pn4A</b>	Electronic Gear Ratio Numerator Exponent						Position
Setting range	0 to 17	Unit	---	Default setting	0	Power OFF→ON	---
<b>Pn4B</b>	Electronic Gear Ratio Denominator						Position
Setting range	0 to 10000	Unit	---	Default setting	10000	Power OFF→ON	---

- Use these parameters to set the electronic gear.
- The electronic gear can be used for the following:
  - To set the amount of Servomotor rotation or movement per input command pulse.
  - To increase the nominal command pulse frequency by using a multiplier when the desired Servomotor speed cannot be achieved due to the limited pulse oscillation capability of the host controller.
- Electronic Gear Block Diagram

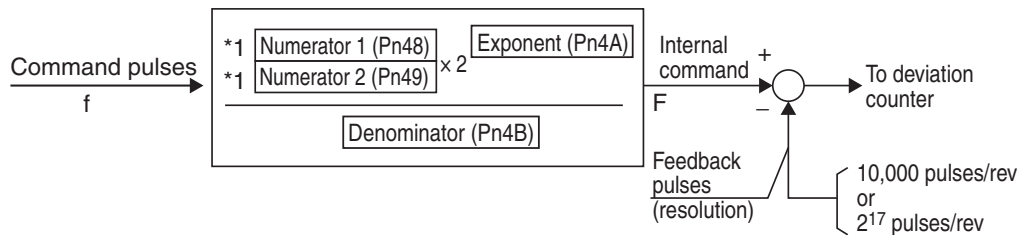

\*1. Numerator 1 or Numerator 2 is selected using the Electronic Gear Switch Input (GESEL: CN1 pin 28).

GESEL input open	Numerator 1 (Pn48) selected.
GESEL input connected to COM	Numerator 2 (Pn49) selected.

- The gear ratio is set using the following equations.  
If the numerator equals 0, the following value is set automatically.

$$\text{Numerator } ((\text{Pn48 or Pn49}) \times 2^{\text{Pn4A}}) = \text{Encoder resolution}$$

In this case, the number of command pulses per revolution can be set in Pn4B.

$$\text{Electronic gear ratio} = \frac{\text{Encoder resolution}}{\text{Number of command pulses per Servomotor rotation (Pn4B)}}$$

If the numerator does not equal 0, the gear ratio is as follows:

$$\text{Electronic gear ratio} = \frac{\text{Electronic gear ratio numerator (Pn48 or Pn49)} \times 2^{\text{Electronic gear ratio numerator exponent (Pn4A)}}}{\text{Electronic gear ratio denominator (Pn4B)}}$$

The upper limit of the calculated numerator  $((\text{Pn48 or Pn49}) \times 2^{\text{Pn4A}})$  is 4,194,304/ (Pn4D setting + 1).

<b>Pn4C</b>	Position Command Filter Time Constant Setting						<b>Position</b>
Setting range	0 to 7	Unit	---	Default setting	0	Power OFF→ON	---

**Explanation of Settings**

Setting	Explanation
0	No filter
1	Time constant: 0.2 ms
2	Time constant: 0.6 ms
3	Time constant: 1.3 ms
4	Time constant: 2.6 ms
5	Time constant: 5.3 ms
6	Time constant: 10.6 ms
7	Time constant: 21.2 ms

- The position command filter is the first-order lag filter for the command pulse input.
- The time constant of the position command filter can be set to one of eight values.
- The position command filter can be used for the following:
  - If the command pulses change abruptly, the filter can be used to reduce the stepping movement of the Servomotor.
  - The following are examples of when the command pulses can change abruptly:  
 The electronic gear setting is high (10 times or higher).  
 The command pulse frequency is low.



<b>Pn4D</b>	Smoothing Filter Setting					<span style="border: 1px solid black; padding: 2px;">Position</span>	
Setting range	0 to 31	Unit	---	Default setting	0	Power OFF→ON	Yes

- Use this parameter to select the FIR filter time constant used for the command pulses (FIR: Finite impulse response).
- The higher the setting, the smoother the command pulses.

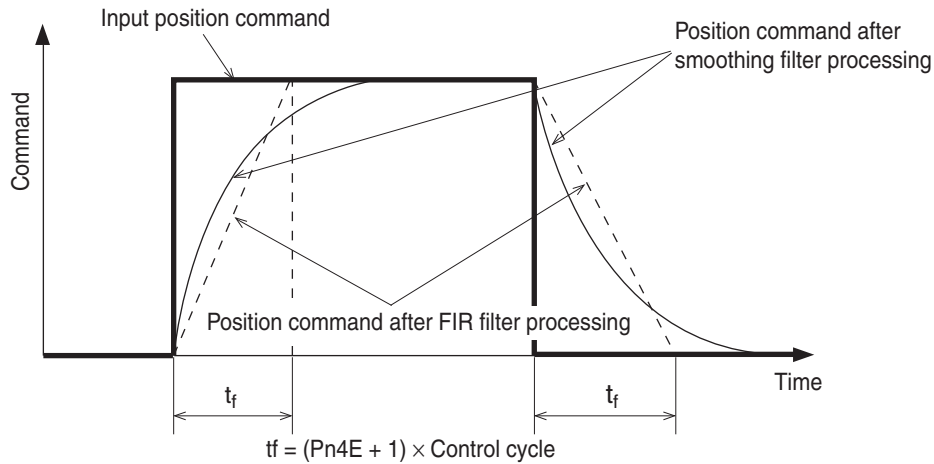

- If the setting is 0, the control cycle will be  $(0 + 1) \times 166 = 166 \mu\text{s}$ .
- If the setting is 1, the control cycle will be  $(1 + 1) \times 166 = 332 \mu\text{s}$ .
- Likewise, if the setting is 31, the control cycle will be  $(31 + 1) \times 166 = 5,312 \mu\text{s}$ .

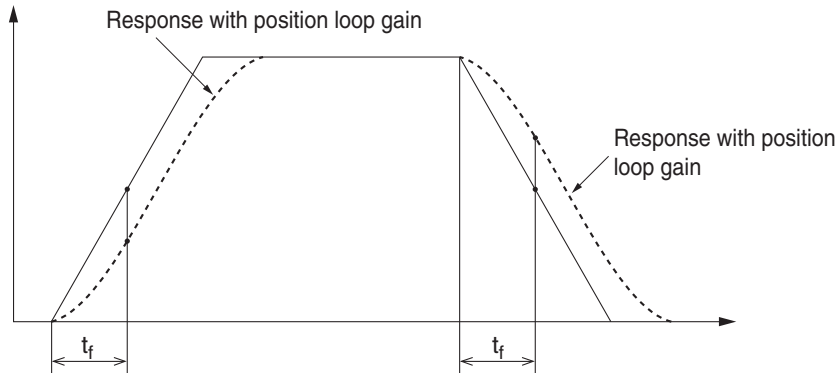

<b>Pn4E</b>	Deviation Counter Reset Condition Setting					<span style="border: 1px solid black; padding: 2px;">Position</span>	
Setting range	0 to 2	Unit	---	Default setting	1	Power OFF→ON	---

**Explanation of Settings**

Setting	Explanation
0	Clears the deviation counter when the signal is closed for 100 μs or longer.
1	Clears the deviation counter on the falling edge of the signal (open and then closed for 100 μs or longer).
2	Disabled

- If Pn4E is set to 0, the minimum time width of the ECRST signal will be as follows:



## ■ Speed and Torque Control Parameters (Pn50 and Higher)

Pn50	Speed Command Scale						Speed	Torque
Setting range	10 to 2000	Unit	(r/min)/V	Default setting	300	Power OFF→ON	---	

- Use this parameter to set the relation between the voltage applied to the Speed Command Input (REF: CN1 pin 14) and the Servomotor speed.
- Refer to *5-2 Speed Control* on page 5-3 for information on speed control.
- Refer to *5-4 Torque Control* on page 5-8 for information on torque control.

Pn51	Command Speed Rotation Direction Switch						Speed
Setting range	0 or 1	Unit	---	Default setting	0	Power OFF→ON	---

### Explanation of Settings

Setting	Explanation
0	Direction of motor rotation: Clockwise (forward) for positive commands when viewing the end of the shaft
1	Direction of motor rotation: Counterclockwise (reverse) for positive commands when viewing the end of the shaft

- Use this parameter to reverse the polarity of the Speed Command Input (REF: CN1 pin 14) to change the Servomotor rotation direction without reversing the polarity of the commands from the host controller.
- This parameter is set to 0 by default (counterclockwise (reverse) for positive commands) for compatibility with all OMNUC W-Series Servo Drives.
- This parameter is disabled if the Zero Speed Designation/Speed Command Direction Switch (Pn06) is set to 2.
- The operation of the Servomotor may be abnormal if the polarity of the speed command signal from the Position Control Unit does not agree with the setting of this parameter when the Servo Drive is in Speed Control Mode and the Servo Drive is used in combination with an external Position Control Unit.

Pn52	Speed Command Offset Adjustment						Speed	Torque
Setting range	-2047 to 2047	Unit	0.3 mV	Default setting	0	Power OFF→ON	---	

- Use this parameter to adjust the offset of the Speed Command Input (REF: CN1 pin 14).
- The offset amount is approximately the set value times 0.3 mV.
- There are two ways to adjust the offset.
  - Manually
  - Automatically
- The manual adjustment is as follows:
  - To adjust the offset for individual Servo Drives, accurately input 0 V to the Speed/Torque Command Input (REF/TREF1) (or connect REF/TREF1 to the signal ground), and then set this parameter so that the Servomotor does not rotate.
  - If you use a position loop in the host controller, set this parameter so that there are no accumulated pulses at servo lock status.
- The automatic adjustment is as follows:
  - This parameter will be automatically set when automatic offset adjustment is executed. Refer to *Automatic Offset Adjustment* on page 6-22 for the procedure.

<b>Pn53</b>	No. 1 Internally Set Speed						Speed	
Setting range	-20000 to 20000	Unit	r/min	Default setting	100	Power OFF→ON	---	

<b>Pn54</b>	No. 2 Internally Set Speed						Speed	
Setting range	-20000 to 20000	Unit	r/min	Default setting	200	Power OFF→ON	---	

<b>Pn55</b>	No. 3 Internally Set Speed						Speed	
Setting range	-20000 to 20000	Unit	r/min	Default setting	300	Power OFF→ON	---	

<b>Pn56</b>	No. 4 Internally Set Speed						Torque Speed	
Setting range	-20000 to 20000	Unit	r/min	Default setting	50	Power OFF→ON	---	

- Pn56 is also the Speed Limit in Torque Control Mode. The Torque Command/Speed Limit Selection (Pn5B) can be used to switch to an external analog limit.

<b>Pn74</b>	No. 5 Internally Set Speed						Speed	
Setting range	-20000 to 20000	Unit	r/min	Default setting	500	Power OFF→ON	---	

<b>Pn75</b>	No. 6 Internally Set Speed						Speed	
Setting range	-20000 to 20000	Unit	r/min	Default setting	600	Power OFF→ON	---	

<b>Pn76</b>	No. 7 Internally Set Speed						Speed	
Setting range	-20000 to 20000	Unit	r/min	Default setting	700	Power OFF→ON	---	

<b>Pn77</b>	No. 8 Internally Set Speed						Speed	
Setting range	-20000 to 20000	Unit	r/min	Default setting	800	Power OFF→ON	---	

- If internally set speed settings are enabled in the Command Speed Selection (Pn05), set the number 1 to 4 internal speeds in Pn53 to Pn56 and the number 5 to 8 internal speeds in Pn74 to Pn77. Set the speed in r/min.
- The polarity of the settings indicates the polarity of the internal command speed.

+	Clockwise (forward) when viewing the end of the shaft
-	Counterclockwise (reverse) when viewing the end of the shaft

- The absolute value of the internally set speed is limited by the Overspeed Detection Level Setting (Pn73).

<b>Pn57</b>	Speed Command Filter Time Constant						Speed Torque	
Setting range	0 to 6400	Unit	0.01 ms	Default setting	0	Power OFF→ON	---	

- Use this parameter to set the first-order lag filter time constant in the Speed Command Input (REF: CN1 pin 14).

## 5-16 User Parameters

<b>Pn58</b>	Soft Start Acceleration Time						Speed
Setting range	0 to 5000	Unit	2 ms/ (1000 r/min)	Default setting	0	Power OFF→ON	---

<b>Pn59</b>	Soft Start Deceleration Time						Speed
Setting range	0 to 5000	Unit	2 ms/ (1000 r/min)	Default setting	0	Power OFF→ON	---

- Use these parameters to set acceleration and deceleration times for the speed command inside the Servo Drive.
- A soft start can be set when inputting speed commands of stepping movement or when using internally set speed.
- Do not set acceleration and deceleration times when using the Servo Drive in combination with an external position loop. (Set both Pn58 and Pn59 to 0.)
- Refer to 5-13 *Soft Start* on page 5-28 for more information on the soft start function.

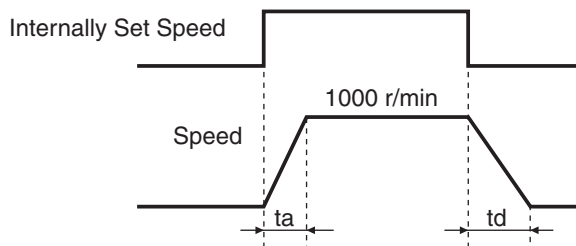

<b>Pn5A</b>	S-curve Acceleration/Deceleration Time Setting						Speed
Setting range	0 to 500	Unit	2 ms	Default setting	0	Power OFF→ON	---

- Use this parameter to set the pseudo-S-curve acceleration/deceleration value to add to the speed command to enable smooth operation. This parameter is useful for applications where impact may occur due to a large change in acceleration or deceleration when starting or stopping with linear acceleration or deceleration.

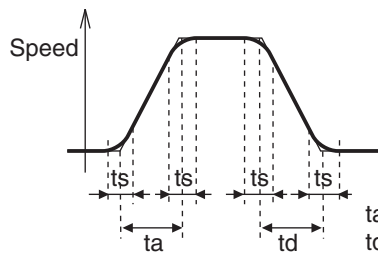

1. Set the linear acceleration and deceleration times in Pn58 and Pn59.
  2. Set the time width for the S-curve portion centered on the inflection points for acceleration and deceleration in Pn5A (unit: 2 ms).
- Set as follows:
- $$\frac{t_a}{2} > t_s \quad \text{and} \quad \frac{t_d}{2} > t_s$$
- $t_a$ : Pn58  
 $t_d$ : Pn59  
 $t_s$ : Pn5A

<b>Pn5B</b>	Torque Command/Speed Limit Selection						Torque
Setting range	0 or 1	Unit	---	Default setting	0	Power OFF→ON	---

### Explanation of Settings

Setting	Control mode	Torque command	Speed limit
0	Torque control	TREF1 (CN1 pin 14)	Pn5b
	Torque control in Position Control/Torque Control Mode		
	Torque control in Speed Control/Torque Control Mode	TREF2 (CN1 pin 16)	
1	Torque control	TREF2 (CN1 pin 16)	VLIM (CN1 pin 14)
	Torque control in Position Control/Torque Control Mode		
	Torque control in Speed Control/Torque Control Mode		

- The use of this parameter depends on the control mode.

<b>Pn5C</b>	Torque Command Scale						Torque
Setting range	10 to 100	Unit	0.1 V/100%	Default setting	30	Power OFF→ON	---

- Use this parameter to set the relation between the voltage applied to the torque command input (TREF1: CN1 pin 14 or TREF2: CN1 pin 16) and the Servomotor's output torque.
- Refer to *5-4 Torque Control* on page 5-8 for information on torque command scaling.

<b>Pn5D</b>	Torque Output Direction Switch						Torque
Setting range	0 or 1	Unit	---	Default setting	0	Power OFF→ON	---

### Explanation of Settings

Setting	Explanation
0	Direction of motor torque: Clockwise (forward) for positive commands when viewing the end of the shaft
1	Direction of motor torque: Counterclockwise (reverse) for positive commands when viewing the end of the shaft

- Use this parameter to reverse the polarity of the Torque Command Input (REF/TREF1: CN1 pin 14 or PCL/TREF2: CN1 pin 16).

## 5-16 User Parameters

Pn5E	No. 1 Torque Limit						All modes
Setting range	0 to 500	Unit	%	Default setting	300	Power OFF→ON	---

Pn5F	No. 2 Torque Limit						Position	Speed
Setting range	0 to 500	Unit	%	Default setting	100	Power OFF→ON	---	

- Use these parameters to set the limit value for the output torque (Pn5E: No. 1 Torque Limit, Pn5F: No. 2 Torque Limit) of the Servomotor.
- Refer to information on the Torque Limit Selection (Pn03) to select the torque limits.
- The maximum torque in the forward and reverse directions is limited in Torque Control Mode, and the settings of the Torque Limit Selection (Pn03) and No. 2 Torque Limit (Pn5F) are ignored.
- Make the settings as a percentage of the rated torque.  
Example: Maximum torque is limited to 150%

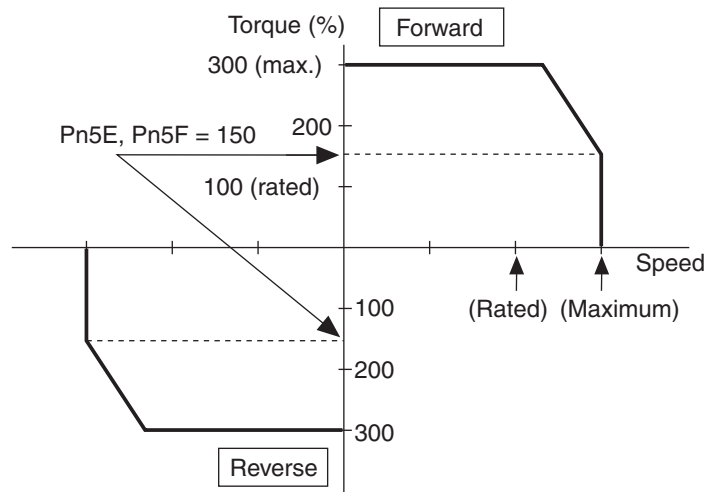

- Refer to 5-12 *Torque Limit* on page 5-26 for information on torque limits and the torque limit selection.

<b>Pn60</b>	Positioning Completion Range						Position
Setting range	0 to 32767	Unit	Pulse	Default setting	25	Power OFF→ON	---

- Use this parameter in combination with the Positioning Completion Condition Setting (Pn63) to set the timing to output the Positioning Completed Output (INP: CN1 pin 39). The Positioning Completed Output (INP) will turn ON when command pulse input is completed, the Servomotor (workpiece) movement stops, and the number of the accumulated pulses in the deviation counter is less than the setting of this parameter.
- For position control, set the number of encoder pulses.
- The basic unit for accumulated pulses is the encoder resolution. The encoder resolutions are as follows:
  - 17-bit encoder:  $2^{17} = 131,072$
  - 2,500-pulse/revolution encoder:  $4 \times 2500 = 10000$
- If this parameter is set to a very small value, the time required for the INP signal to turn ON will increase and the output may chatter. The setting of the Positioning Completion Range does not affect the precision of the final position.

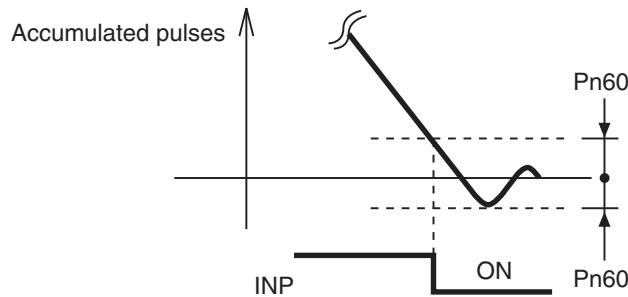

<b>Pn61</b>	Zero Speed Detection						All modes
Setting range	10 to 20000	Unit	r/min	Default setting	20	Power OFF→ON	---

- Use this parameter to set the rotation speed threshold at which to output a zero speed detection output or speed coincidence output from the general-purpose output (OUTM1: CN1 pin 12 or OUTM2: CN1 pin 40).
- If a speed detection output is assigned, an output will be made when the speed of the motor is lower than the value set for this parameter.
- If a speed coincidence output is assigned, an output will be made when difference between the speed command and the speed of the motor is lower than the value set for this parameter.
- The setting of this parameter is valid for both forward and reverse operation regardless of the Servomotor rotation direction. This setting has a hysteresis of 10 r/min.

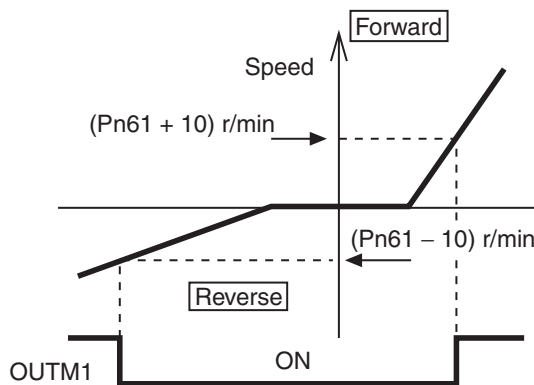

<b>Pn62</b>	Rotation Speed for Motor Rotation Detection					Speed	Torque
Setting range	10 to 20000	Unit	r/min	Default setting	50	Power OFF→ON	---

- Use this parameter to set the rotation speed (r/min) at which to output the Servomotor Rotation Detection Output (TGON: CN1 pin 39, TGONCOM: CN1 pin 38).
- The Servomotor Rotation Detection Output (TGON) will turn ON when the Servomotor speed exceeds the setting of this parameter.
- The setting of this parameter is valid for both forward and reverse operation regardless of the Servomotor direction. This setting has a hysteresis of 10 r/min.

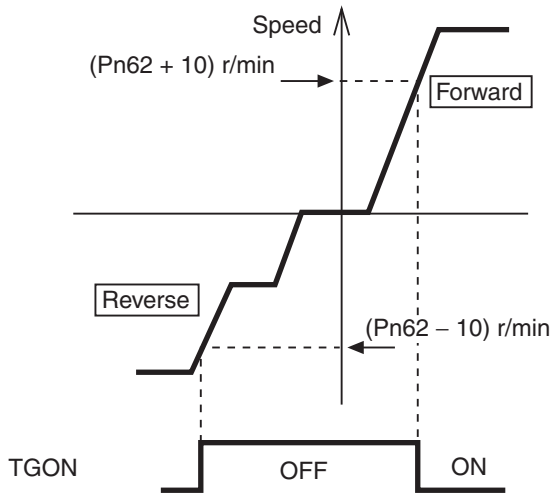

<b>Pn63</b>	Positioning Completion Condition Setting					Position	
Setting range	0 to 3	Unit	---	Default setting	0	Power OFF→ON	---

**Explanation of Settings**

Setting	Explanation
0	Positioning completion output turns ON when the position deviation is within the Positioning Completion Range (Pn60).
1	Positioning completion output turns ON when the position deviation is within the Positioning Completion Range (Pn60) and there is no position command.
2	Positioning completion output turns ON when the zero speed detection signal is ON, the position deviation is within the Positioning Completion Range (Pn60), and there is no position command.
3	Positioning completion output turns ON when the position deviation is within the Positioning Completion Range (Pn60) and there is no position command. The ON status will be maintained until the next position command is received.

- Use this parameter in combination with the Positioning Completion Range (Pn60) to set the operation for Positioning Completed Output (INP: CN1 pin 39).



<b>Pn65</b>	Undervoltage Alarm Selection						All modes
Setting range	0 or 1	Unit	---	Default setting	1	Power OFF→ON	---

### Explanation of Settings

Setting	Explanation
0	When the main power supply is interrupted during Servo ON status, a main power supply undervoltage alarm (alarm code 13) does not occur and the Servo OFF status is entered. When the main power supply turns ON again, the Servo ON status is reset.
1	When the main power supply is interrupted during Servo ON status, an error occurs for a main power supply undervoltage (alarm code 13).

- Use this parameter to select whether to activate the main power supply undervoltage function (alarm code 13) if the main power supply is interrupted for the Momentary Hold Time (Pn6D).
- If the Momentary Hold Time (Pn6D) is set to 1,000, Pn65 is disabled.
- If the setting of Momentary Hold Time (Pn6D) is too long and the voltage between P and N in the main power supply converter drops below the specified value before a main power supply interruption is detected, a main power supply undervoltage (alarm code 13) will occur regardless of the setting of Pn65.

<b>Pn66</b>	Stop Selection for Drive Prohibition Input						All modes
Setting range	0 to 2	Unit	---	Default setting	0	Power OFF→ON	Yes

### Explanation of Settings

Setting	Explanation
0	During deceleration: The dynamic brake is activated. After stopping: The torque command in the drive prohibit direction is set to 0. Deviation counter contents: Held
1	During deceleration: The torque command in the drive prohibit direction is set to 0. After stopping: The torque command in the drive prohibit direction is set to 0. Deviation counter contents: Held
2	During deceleration: An emergency stop is performed. After stopping: The servo is locked. Deviation counter contents: Cleared before and after deceleration.

- Use this parameter to set the drive conditions during deceleration or after stopping after the Forward Drive Prohibit Input (POT: CN1 pin 9) or Reverse Drive Prohibit Input (NOT: CN1 pin 8) is enabled.
- If this parameter is set to 2, the Emergency Stop Torque (Pn6E) will be used to limit the torque during deceleration.
- With a vertical axis, there is a risk that the load may drop when drive is prohibited by the drive prohibit input. To prevent this, it is recommended that the deceleration method be set to use emergency stop torque in the Drive Prohibit Input Stop Selection parameter (Pn066), and that stopping in the servo-lock state be set (set value: 2).
- The dynamic brake is intended for emergency stop.  
If the dynamic brake is activated, provide an interval of 3 minutes or more before the next activation.

<b>Pn67</b>	Stop Selection with Main Power OFF						<b>All modes</b>
Setting range	0 to 9	Unit	---	Default setting	0	Power OFF→ON	---

**Explanation of Settings**

Setting	Explanation		
	During deceleration	After stopping	Deviation counter
0	Dynamic brake	Dynamic brake	Cleared
1	Free run	Dynamic brake	Cleared
2	Dynamic brake	Servo free	Cleared
3	Free run	Servo free	Cleared
4	Dynamic brake	Dynamic brake	Held
5	Free run	Dynamic brake	Held
6	Dynamic brake	Servo free	Held
7	Free run	Servo free	Held
8	Emergency stop	Dynamic brake	Cleared
9	Emergency stop	Servo free	Cleared

- Use this parameter to set the operation to be performed after the main power supply is shut off if the Undervoltage Alarm Selection (Pn65) is set to 0.
  - Operation during deceleration and after stopping
  - Clearing the deviation counter
- If this parameter is set to 8 or 9, the Emergency Stop Torque (Pn6E) will be used to limit the torque during deceleration.
- The dynamic brake is intended for emergency stop.  
If the dynamic brake is activated, provide an interval of 3 minutes or more before the next activation.

<b>Pn68</b>	Stop Selection for Alarm Generation						<b>All modes</b>
Setting range	0 to 3	Unit	---	Default setting	0	Power OFF→ON	---

**Explanation of Settings**

Setting	Explanation		
	During deceleration	After stopping	Deviation counter
0	Dynamic brake	Dynamic brake	Held
1	Free run	Dynamic brake	Held
2	Dynamic brake	Servo free	Held
3	Free run	Servo free	Held

- Use this parameter to set the operation to be performed after stopping or during deceleration when any protective function of the Servo Drive operates and an error occurs.
- The deviation counter is cleared when an alarm is cleared.
- The dynamic brake is intended for emergency stop.  
If the dynamic brake is activated, provide an interval of 3 minutes or more before the next activation.

<b>Pn69</b>	Stop Selection with Servo OFF						All modes
Setting range	0 to 9	Unit	---	Default setting	0	Power OFF→ON	---

- Use this parameter to set the operation to be performed after Servo OFF status is entered (i.e., after RUN (CN1 pin 29) changes from ON to OFF).
  - Operation during deceleration and after stopping
  - Clearing the deviation counter
- The relations between set values, operation, and deviation counter processing for this parameter are the same as for the Stop Selection with Main Power OFF (Pn67).

<b>Pn6A</b>	Brake Timing When Stopped						All modes
Setting range	0 to 100	Unit	2 ms	Default setting	10	Power OFF→ON	---

- Use this parameter to set the brake timing from when the Brake Interlock Output (BKIRCOM: CN1 pin 10, BKIR: CN1 pin 11) turns OFF (i.e., braking held) until the Servomotor is deenergized (servo free) when Servo OFF status is entered while the Servomotor is stopped.
- When the RUN Command Input is turned OFF while the Servomotor is stopped, the Brake Interlock Signal (BKIR) will turn OFF, and the Servo will turn OFF after the time set for this parameter (setting × 2 ms) elapses.

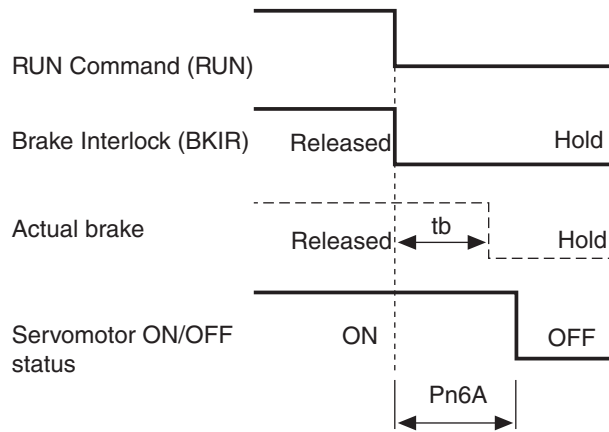

- Make the setting as follows to prevent the machine (workpiece) from moving or falling due to the delay in the brake operation (tb).  
 Brake timing when stopped (setting × 2 ms) ≥ tb
- Refer to 5-10 Brake Interlock on page 5-21 for more information.

## 5-16 User Parameters

Pn6B	Brake Timing during Operation						All modes
Setting range	0 to 100	Unit	2 ms	Default setting	50	Power OFF→ON	---

- Use this parameter to set the brake timing from when the RUN Command Input (RUN: CN1 pin 29) is detected to be OFF until the Brake Interlock Output (BKIRCOM: CN1 pin 10, BKIR: CN1 pin 11) turns OFF when Servo OFF status is entered while the Servomotor is operating. When the RUN Command Input is turned OFF while the Servomotor is operating, the Servomotor will decelerate reducing the number of rotations, and the Brake Interlock Signal (BKIR) will turn OFF after the time set for this parameter has elapsed (setting × 2 ms).

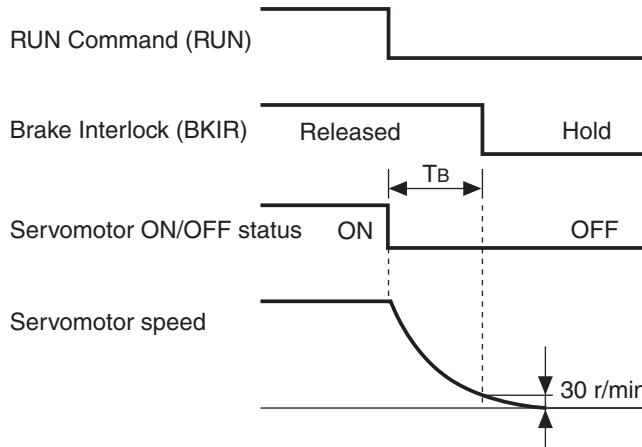

“TB” in the above figure is the brake timing during operation (setting × 2 ms) or the time until the speed of the Servomotor falls to 30 r/min or lower, whichever is shorter.

- Refer to 5-10 *Brake Interlock* on page 5-21 for more information.

<b>Pn6C</b>	Regeneration Resistor Selection						All modes	
Setting range	0 to 3	Unit	---	Default setting	0	Power OFF→ON	Yes	

### Explanation of Settings

Setting	Explanation
0	Regeneration resistor used: Built-in resistor The regeneration processing circuit will operate and the regeneration overload (alarm code 18) will operate according to the internal resistor (with approximately 1% duty).
1	Regeneration resistor used: External resistor The regeneration processing circuit will operate, and regeneration overload (alarm code 18) will cause a trip when the operating rate of the regeneration resistor exceeds 10%.
2	Regeneration resistor used: External resistor The regeneration processing circuit will operate, but regeneration overload (alarm code 18) will not.
3	Regeneration resistor used: None The regeneration processing circuit and regeneration overload (alarm code 18) will not operate, and all regenerative energy will be processed by the built-in capacitor.

- Do not touch the External Regeneration Resistor. It can be very hot and may cause burns.
- Always provide a temperature fuse or other protective measure when using an External Regeneration Resistor. Regardless of whether the regeneration overload is enabled or disabled, the External Regeneration Resistor can become extremely hot and may cause burning.
- Set this parameter depending on whether the built-in regeneration resistor is used, or the built-in regeneration resistor is disconnected and an External Regeneration Resistor is connected. (The External Regeneration Resistor is connected between B1 and B2.)
- To use the built-in regeneration resistor, always set this parameter to 0.

<b>Pn6D</b>	Momentary Hold Time						All modes	
Setting range	35 to 1000	Unit	2 ms	Default setting	35	Power OFF→ON	Yes	

- Use this parameter to set the amount of time required until shutoff is detected if the main power supply remains shut off.
- The main power OFF detection will be disabled if this parameter is set to 1000.

<b>Pn6E</b>	Emergency Stop Torque						All modes	
Setting range	0 to 500	Unit	%	Default setting	0	Power OFF→ON	---	

- Use this parameter to set the torque limit for the following cases.
  - Drive prohibit deceleration with the Stop Selection for Drive Prohibition Input (Pn66) set to 2.
  - Deceleration with the Stop Selection with Main Power OFF (Pn67) set to 8 or 9.
  - Deceleration with the Stop Selection with Servo OFF (Pn69) set to 8 or 9.
- The normal torque limit will be used if this parameter is set to 0.

<b>Pn70</b>	Deviation Counter Overflow Level						
Setting range	0 to 32767	Unit	256 × resolution	Default setting	100	Power OFF→ON	---

- Use this parameter to set the deviation counter overflow level.
- The set value is calculated using the following formula.  
Set value = Deviation counter overflow detection pulses [pulses]/256

## 5-16 User Parameters

- If the positioning loop gain is small and the setting of this parameter is too small, a deviation counter overflow (alarm code 24) may be detected even during normal operation.
- Deviation counter overflow (alarm code 24) will not be detected if this parameter is set to 0.

<b>Pn71</b>	Speed Command/Torque Command Input Overflow Level Setting						<input type="checkbox"/> Speed	<input type="checkbox"/> Torque
Setting range	0 to 100	Unit	0.1 V	Default setting	0	Power OFF→ON	---	

- Use this parameter to set the overflow level for Speed Command Input (REF: CN1 pin 14) or Torque Command Input (TREF1: CN1 pin 14) using voltage after offset adjustment.
- Excessive analog input (alarm code 39) will not be detected if this parameter is set to 0.

<b>Pn72</b>	Overload Detection Level Setting						<input type="checkbox"/> All modes
Setting range	0 to 115	Unit	%	Default setting	0	Power OFF→ON	---

- Use this parameter to set the overload detection level.
- The overload detection level will be 115% if this parameter is set to 0.
- This parameter should normally be set to 0. The setting should be changed only when it is necessary to reduce the overload detection level.
- The setting of this parameter is limited to 115% of the Servomotor rating.

<b>Pn73</b>	Overspeed Detection Level Setting						<input type="checkbox"/> All modes
Setting range	0 to 20000	Unit	r/min	Default setting	0	Power OFF→ON	---

- Use this parameter to set the overspeed detection level.
- The overspeed detection level will be 1.2 times the maximum Servomotor rotation speed if this parameter is set to 0.
- This parameter should normally be set to 0. The setting should be changed only when it is necessary to reduce the overspeed detection level.
- The setting of this parameter is limited to 1.2 times the maximum Servomotor rotation speed.
- The detection margin of error for the setting is  $\pm 3$  r/min for a 7-core absolute encoder and  $\pm 36$  r/min for a 5-core incremental encoder.

# Chapter 6

## Operation

6-1	Operational Procedure .....	6-1
6-2	Preparing for Operation.....	6-2
	Items to Check Before Turning ON the Power.....	6-2
	Turning ON Power .....	6-3
	Checking Displays .....	6-3
	Absolute Encoder Setup .....	6-5
6-3	Using the Parameter Unit.....	6-6
	Names of Parts and Functions.....	6-6
6-4	Setting the Mode .....	6-7
	Changing the Mode.....	6-7
	Monitor Mode .....	6-8
	Parameter Setting Mode .....	6-17
	Parameter Write Mode .....	6-19
	Normal Mode Autotuning .....	6-20
	Auxiliary Function Mode.....	6-21
	Copy Mode.....	6-25
6-5	Trial Operation .....	6-28
	Preparation for Trial Operation .....	6-28
	Trial Operation in Position Control Mode .....	6-28
	Trial Operation in Speed Control Mode .....	6-29
	Trial Operation in Torque Control Mode .....	6-29

# 6-1 Operational Procedure

After mounting, wiring, and connecting a power supply, check the operation of the Servomotor and Servo Drive. Then make the function settings as required according to the use of the Servomotor and Servo Drive. If the parameters are set incorrectly, there is a risk of an unpredictable Servomotor operation. Set the parameters according to the instructions in this manual.

Item	Contents	Reference
Mounting and installation	Install the Servomotor and Servo Drive according to the installation conditions. (Do not connect the Servomotor to the mechanical system before checking the no-load operation.)	4-1 <i>Installation Conditions</i>
Wiring and connections	Connect the Servomotor and Servo Drive to the power supply and peripheral devices. Specified installation and wiring requirements must be satisfied, particularly for models conforming to the EC Directives.	4-2 <i>Wiring</i>
Preparing for operation	Check the necessary items and then turn ON the power supply. Check on the display to see whether there are any internal errors in the Servo Drive. If using a Servomotor with an absolute encoder, first set up the absolute encoder.	6-2 <i>Preparing for Operation</i>
Setting functions	By means of the user parameters, set the functions according to the operating conditions.	5-16 <i>User Parameters</i>
Trial operation	First, test operation without a load connected to the motor. Then turn the power OFF and connect the mechanical system to the motor. If using a Servomotor with an absolute encoder, set up the absolute encoder and set the Motion Control Unit's initial parameters. Turn ON the power, and check to see whether protective functions, such as the emergency stop and operational limits, work properly. Check operation at both low speed and high speed using the system without a workpiece, or with dummy workpieces. Even without a load, the Servomotor may vibrate. If the Inertia Ratio (Pn20) is set low, adjust the gain as required for operation.	6-5 <i>Trial Operation</i>
Adjustments	Manually adjust the gain if necessary. Further adjust the various functions to improve the control performance.	Chapter 7 <i>Adjustment Functions</i>
Operation	Operation can now be started. If any problems should occur, refer to Chapter 8 <i>Troubleshooting</i> .	Chapter 8 <i>Troubleshooting</i>



## 6-2 Preparing for Operation

This section explains the procedure to prepare the mechanical system for operation following installation and wiring of the Servomotor and Servo Drive. It explains what you need to check both before and after turning ON the power.

It also explains the setup procedure required if using a Servomotor with an absolute encoder.

### Items to Check Before Turning ON the Power

#### ■ Checking Power Supply Voltage

- Check to be sure that the power supply voltage is within the ranges shown below.
  - R88D-GT□L (single-phase 100 VAC input)
    - Main-circuit power supply: Single-phase 100 to 115 VAC (85 to 127 V) 50/60 Hz
    - Control-circuit power supply: Single-phase 100 to 115 VAC (85 to 127 V) 50/60 Hz
  - R88D-GT01H/02H/04H/08H/10H/15H (single-phase or single-phase/three-phase 200 VAC input)
    - Main-circuit power supply: Single-phase or single-phase/three-phase 200 to 240 VAC (170 to 264 V), 50/60 Hz
    - Control-circuit power supply: Single-phase or single-phase/three-phase 200 to 240 VAC (170 to 264 V), 50/60 Hz
  - R88D-GT20H/30H/50H/75H (three-phase 200 VAC input)
    - Main-circuit power supply: Three-phase 200 to 230 VAC (170 to 253 V), 50/60 Hz
    - Control-circuit power supply: Single-phase 200 to 230 VAC (170 to 253 V), 50/60 Hz

#### ■ Checking Terminal Block Wiring

- The main-circuit power supply input lines (L1/L3 or L1/L2/L3) must be properly connected to the terminal block.
- The control-circuit power supply inputs (L1C/L2C) must be properly connected to the terminal block.
- The Servomotor's red (U), white (V), and blue (W) power lines and the green/yellow ground wire (⊕) must be properly connected to the terminal block.

#### ■ Checking the Servomotor

- There should be no load on the Servomotor. (Do not connect the mechanical system.)
- The Servomotor's power lines and the power cables must be securely connected.

#### ■ Checking the Encoder Connectors

- The Encoder Cable must be securely connected to the Encoder Connector (CN2) at the Servo Drive.
- The Encoder Cable must be securely connected to the Encoder Connector at the Servomotor.

#### ■ Checking the Control I/O Connectors

- The Control Cable must be securely connected to the Control I/O Connector (CN1).
- The RUN Command Input (RUN) must be OFF.

#### ■ Checking Parameter Unit Connections

- When using the Parameter Unit (R88A-PR02G), the enclosed cable must be securely connected to the CN3B connector.

### Turning ON Power

- First carry out the preliminary checks, and then turn ON the control-circuit power supply. It makes no difference whether or not the main-circuit power supply is turned ON.
- The alarm (/ALM) output will take approximately 2 seconds to turn ON after the power has been turned ON. Do not attempt to detect an alarm using the Host Controller during this time (if power is turned ON while the Host Controller is connected).

### Checking Displays

#### ■ Displays on the Servo Drive

- The following will appear on the display on the Servo Drive when the power supply is turned ON.

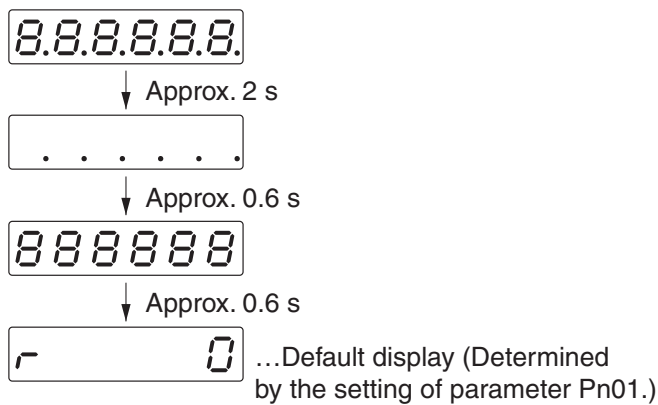

■ Displays on the Parameter Unit

- Connect the Parameter Unit to the Servo Drive and turn ON the power to the Servo Drive, or alternatively, connect the Parameter Unit to the Servo Drive when power to the Servo Drive is already ON. The following displays will appear.

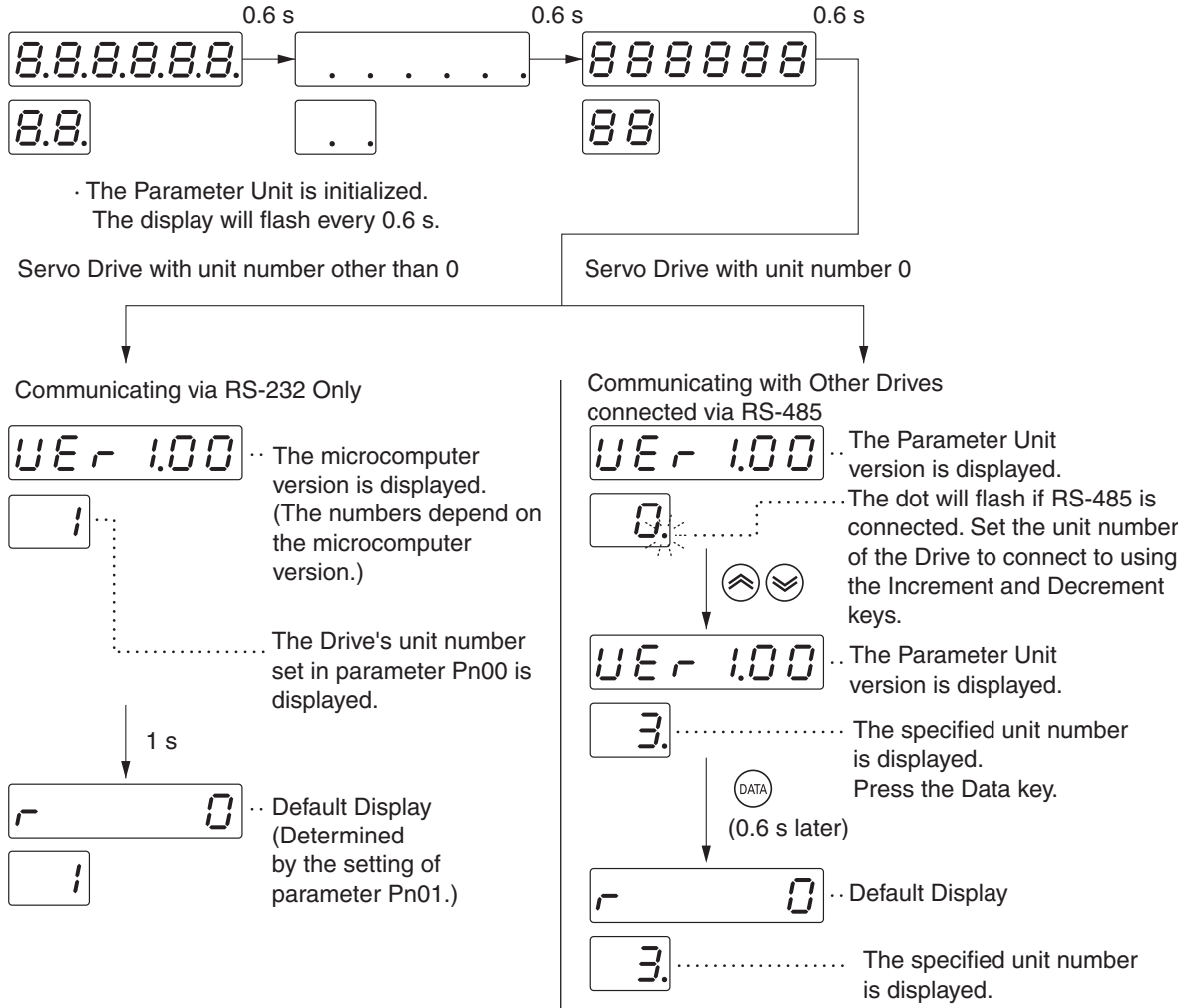

## Absolute Encoder Setup **ABS**

You must set up the absolute encoder if using a Servomotor with an absolute encoder. The setup is also required if an absolute encoder system down error (alarm code 40) occurs when you turn ON the power supply for the first time or if the encoder cable is disconnected and then connected again.

When using an absolute encoder, set Pn0B to 0 or 2 and set Pn45 to 0.

### ■ Absolute Encoder Setup Procedure

**1. Turn ON the power supply and align the origin.**

Turn ON the power supply, perform the origin alignment operation, and move the machine to the origin position.

**2. Go to Auxiliary Function Mode.**

Press the Data key and Mode key on the Servo Drive. Auxiliary Function Mode will be displayed.

**3. Go to Absolute Encoder Clear Mode.**

Press the Data key again. Absolute Encode Clear Mode will be displayed.

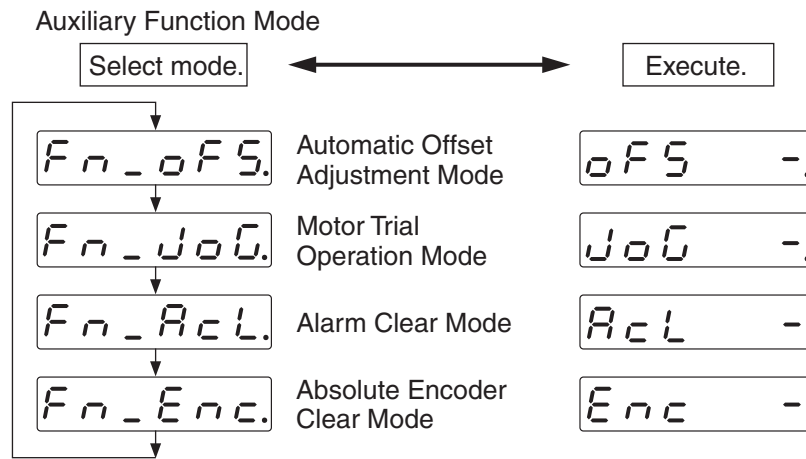

**4. Start clearing the absolute encoder.**

Hold down the Increment key. Clearing the absolute encoder will be started.

Hold down the Increment key for approx. 3 seconds. The number of dashes on the display will increase.

Clearing the absolute encoder will be started.

Clearing will be finished almost immediately.

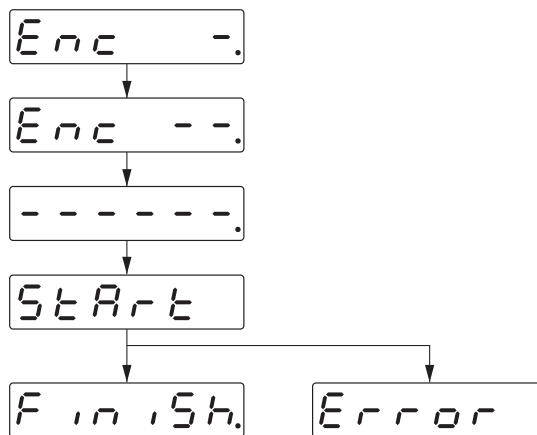

**Note:** If you attempt to clear an incremental encoder, "Error" will be displayed.

**5. Restart the Servo Drive.**

Turn OFF the control power supply to the Servo Drive and then turn it back ON.

## 6-3 Using the Parameter Unit

### Names of Parts and Functions

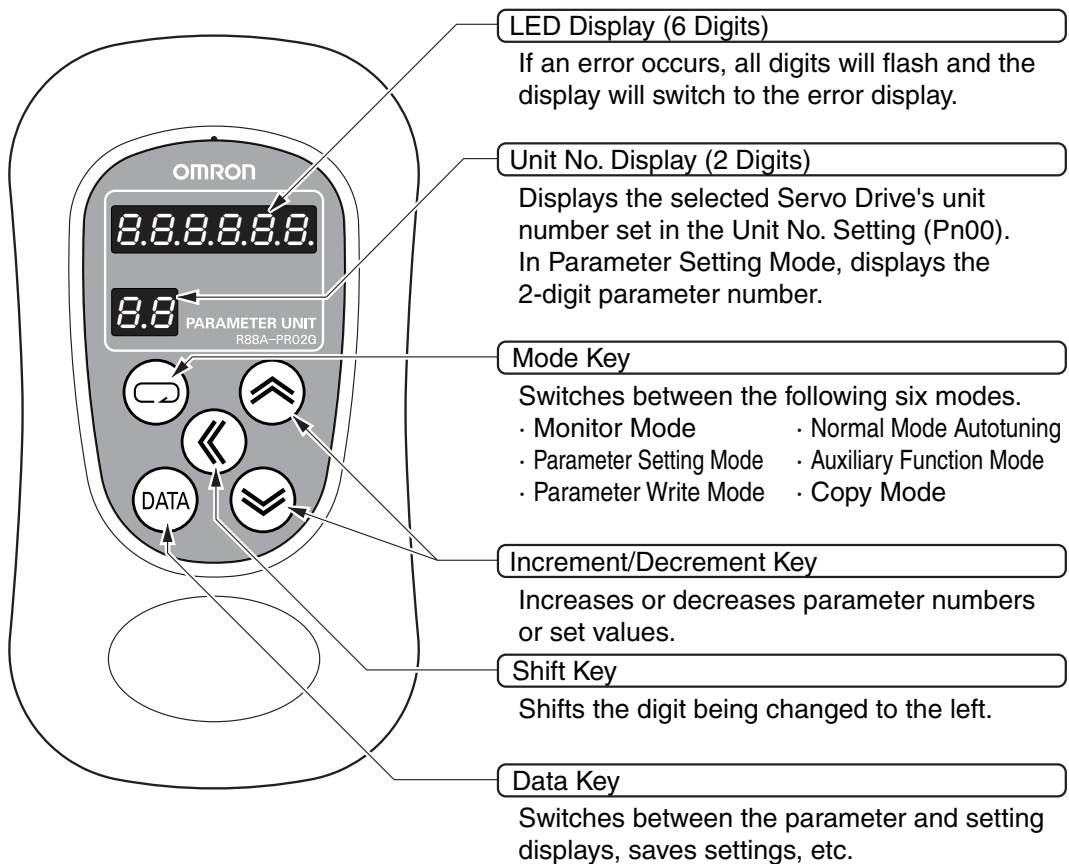
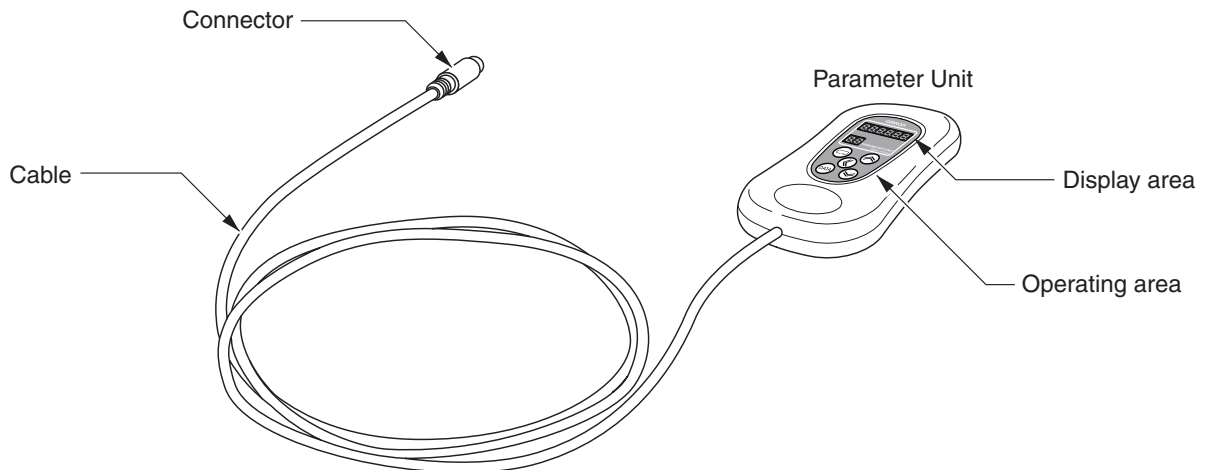

# 6-4 Setting the Mode

## Changing the Mode

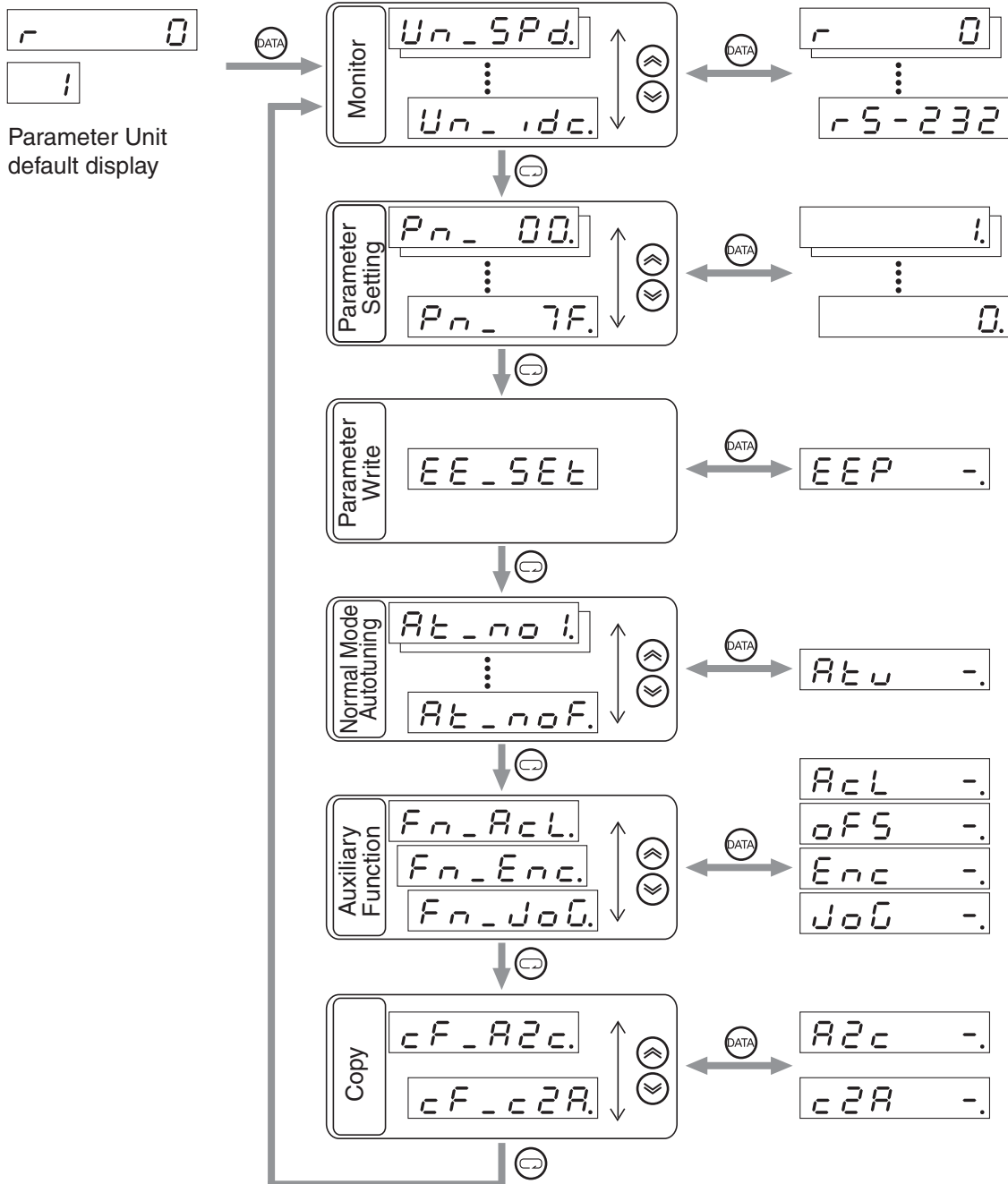

Monitor Mode

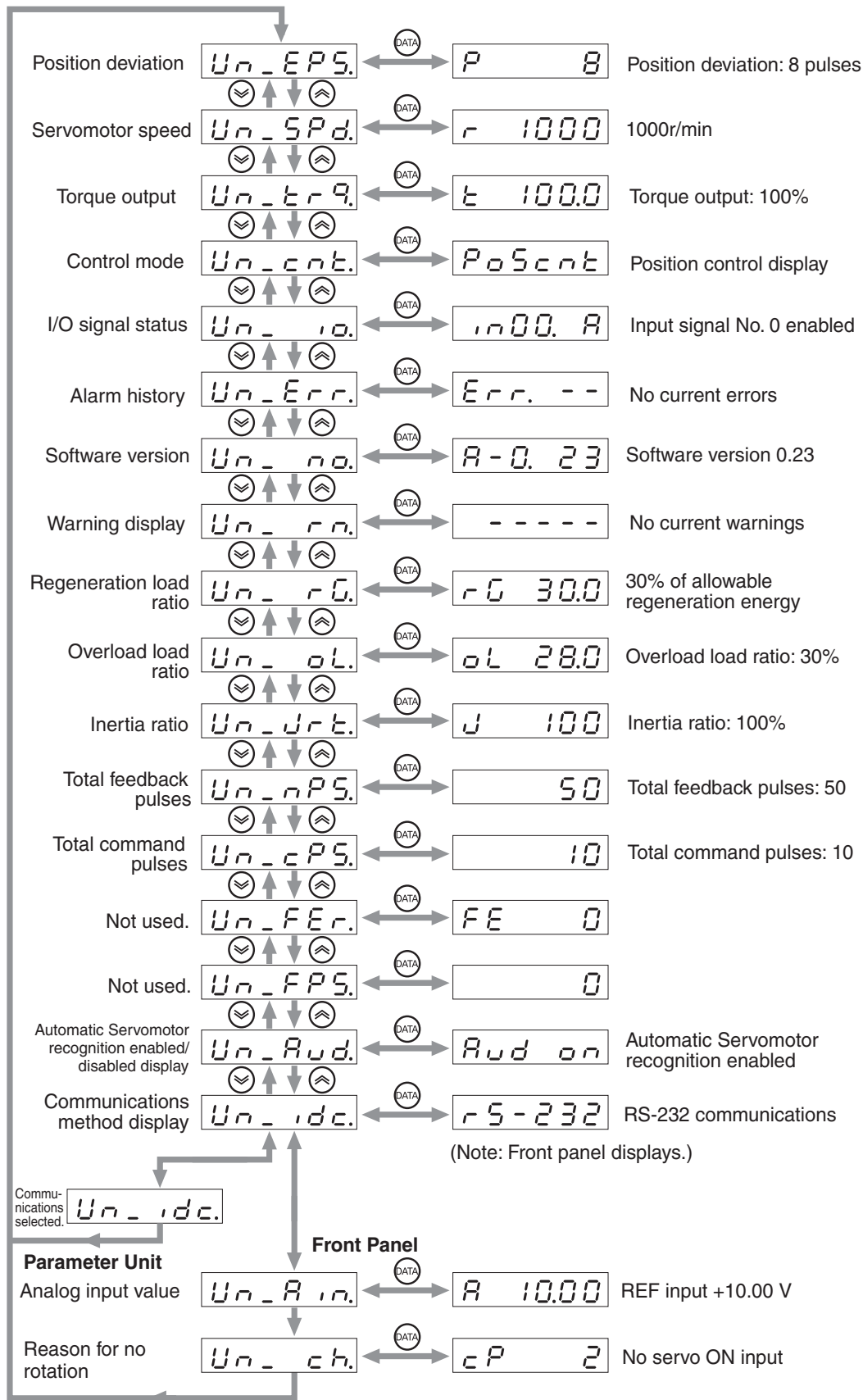

## 6-4 Setting the Mode

- The Servomotor speed will be displayed the first time the power is turned ON after purchase. To change the initial display when the power is turned ON, change the setting for the Default Display (Pn01). For details, refer to *Pn01 Default Display* on page 5-52.

### ■ Position Deviation

P 8

- Displays the number of accumulated pulses in the deviation counter (unit: pulse).
- Accumulated pulses in reverse rotation are displayed with “-”.

### ■ Servomotor Speed

r 1000

- Displays the Servomotor speed (unit: r/min).
- Speeds in reverse rotation are displayed with “-”.

### ■ Torque Output

t 100.0

- Displays the percentage of Servomotor torque output.
- When the rated torque output for the Servomotor is used, “100%” is displayed.
- Torque outputs in reverse rotation are displayed with “-”.

### ■ Control Mode

Poscnt Position Control Mode

SPdcnt Speed Control Mode

tr9cnt Torque Control Mode

- Displays whether position control, speed control, or torque control is being used.



## ■ I/O Signal Status

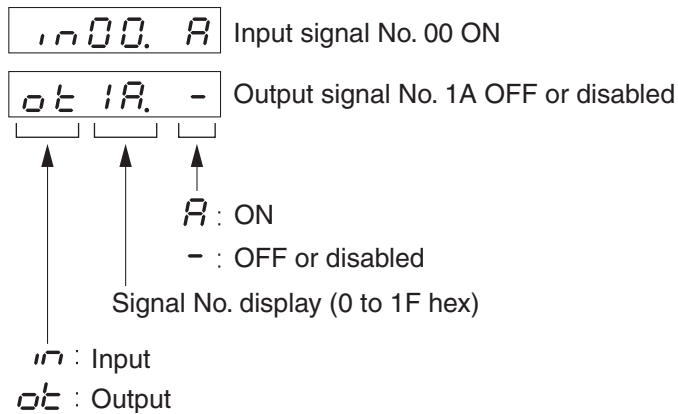

- Displays the status of the control input and output signals connected to CN1.

### Input Signals

CN1			
Signal No.	Abbreviation	Name	Pin No.
00	RUN	RUN command	29
01	RESET	Alarm reset	31
02	NOT	Reverse drive prohibit	8
03	POT	Forward drive prohibit	9
04	TVSEL	Control mode switch	32
05	VZERO	Zero speed designation	26
06	GESEL	Electronic gear switch	28
08	IPG	Pulse disable	33
09	GSEL	Gain switch	27
0A	ECRST	Deviation counter reset	30
0C	VSEL1	Internally set speed selection 1	33
0D	VSEL2	Internally set speed selection 2	30
13	DFSEL	Vibration filter switch	26
14	VSEL3	Internally set speed selection 3	28
15	TLSEL	Torque limit switch	27

Output Signals

CN1			
Signal No.	Abbreviation	Name	Pin No.
00	READY	Servo Ready	35
01	/ALM	Alarm Output	37
02	INP	Positioning Completion Output	39
03	BKIR	Brake Interlock	11
04	OUTM1	Zero Speed Detection	12
05	OUTM2	Torque Limiting	40
06	---	Speed Conformity	12/40
09	TGON	Servomotor Rotation Speed Detection	39

Switching between Input Signals and Output Signals

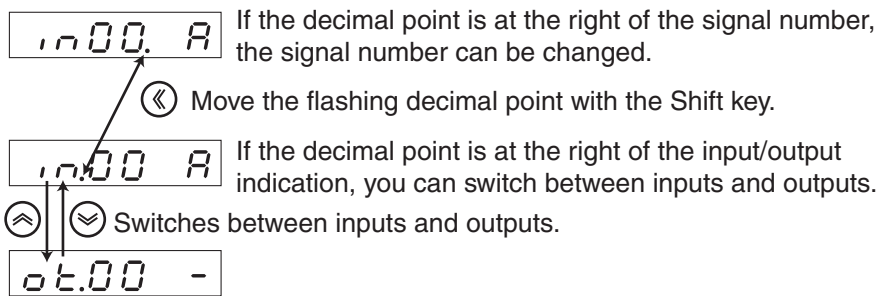

The following procedure can also be used to switch between inputs and outputs.

Press the Increment or Decrement key to select the signal number to be monitored.

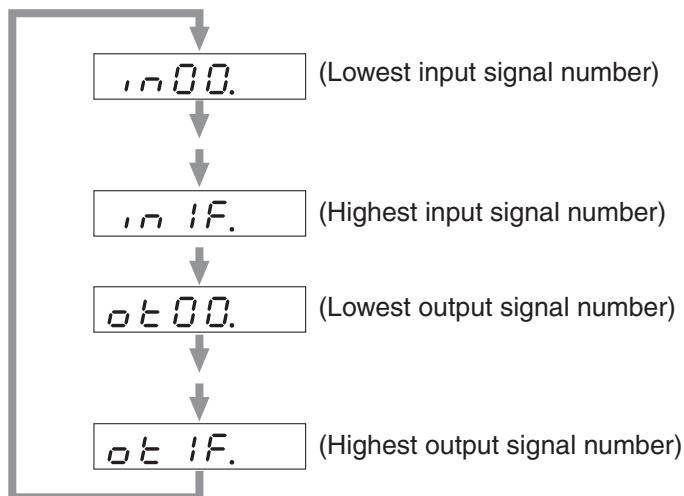

■ Alarm History

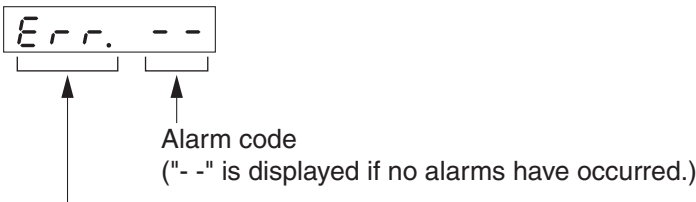

Err. : Current alarm

E - 0 : Alarm 0 (newest alarm)

E 13 : Alarm 13 (oldest alarm)

- Up to the most recent 14 alarms, including the current one, can be viewed in the alarm history.
- The display will flash when an alarm occurs.
- If an alarm that is recorded in the history occurs, the alarm code for the current alarm and for alarm 0 will be the same.

### Alarm Codes and Meanings

Alarm codes	Meaning	Alarm codes	Meaning
11	Control power supply undervoltage	45	Multi-turn counter error
12	Overvoltage	46	Encoder error 1
13	Undervoltage	47	Absolute encoder status error <b>ABS</b>
14	Overcurrent	48	Encoder phase Z error
15	Servo Drive overheat	49	Encoder PS signal error
16	Overload	58	CPU error 1
18	Regeneration overload	60	CPU error 2
21	Encoder disconnection detected	61	CPU error 3
23	Encoder communications error	62	CPU error 4
24	Deviation counter overflow	63	CPU error 5
26	Overspeed	65	Excessive analog input 2
27	Electronic gear setting error	66	Excessive analog input 3
34	Overrun limit error	73	CPU error 6
36	Parameter error	77	CPU error 7
37	Parameter corruption	81	CPU error 8
38	Drive prohibit input error	94	Encoder error 2
39	Excessive analog input 1	95	Servomotor non-conformity
40	Absolute encoder system down error <b>ABS</b>	96	CPU error 9
41	Absolute encoder counter overflow error <b>ABS</b>	97	CPU error 10
42	Absolute encoder overspeed error <b>ABS</b>	99	CPU error 11
44	One-turn counter error		

**Note** The following alarms are not recorded in the history.

- 11: Control power supply undervoltage
- 13: Undervoltage
- 36: Parameter error
- 37: Parameter corruption
- 38: Drive prohibit input error
- 95: Servomotor non-conformity

### ■ Software Version

A-0.23

- Displays the software version of the Servo Drive.

■ Warning Display

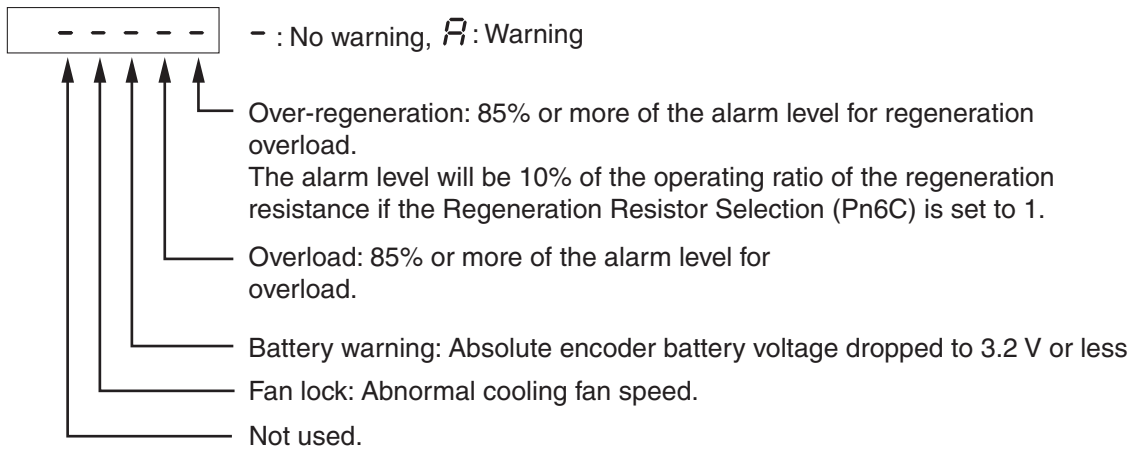

■ Regeneration Load Ratio

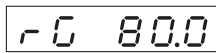

- Displays the regeneration resistance load ratio as a percentage of the detection level for the regeneration load.

■ Overload Load Ratio



- Displays the load ratio as a percentage of the rated load.

■ Inertia Ratio



Displays the inertia ratio as a percentage.

■ Total Feedback Pulses and Total Command Pulses



- Displays the total number of pulses after the power supply is turned ON.
- The display on the front panel will overflow as shown in the following figure.

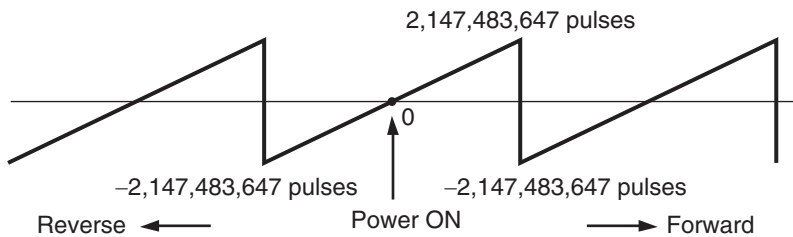

- The display on the Parameter Unit will be as shown in the following figure.
- Use the Shift key to switch the display between the upper and lower digits of the total number of pulses.



- Hold down the Data key for 5 s or longer to reset the total pulses to 0.

## 6-4 Setting the Mode

### ■ Automatic Servomotor Recognition

`Aud on` Automatic recognition enabled (Always this indication is displayed.)

### ■ Analog Input Value Display (Front Panel Operation)

`A 10.00`  
↑            ↑  
Input signal    Input voltage (V)

Press the Increment or Decrement key to select the signal to monitor.

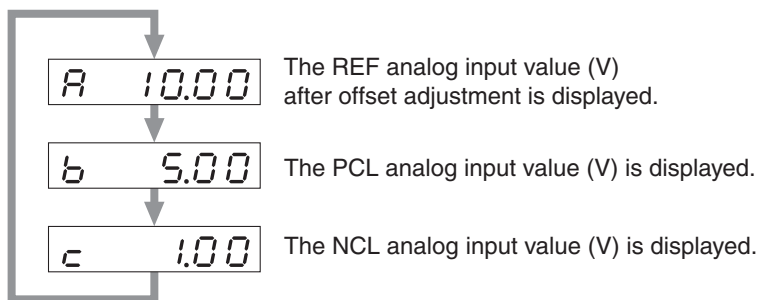

**Note:** The displayed value will not be accurate if the voltage exceeds  $\pm 10$  V.

## Reason for No Rotation Display (Front Panel Operation)

A number is displayed to indicate the reason the Servomotor does not rotate.

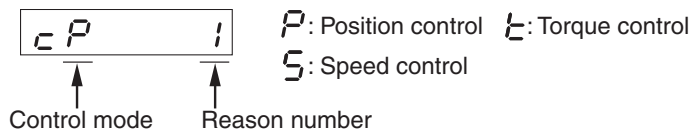





No.	Reason	Relevant control modes	Description
Flashing	Error or warning has occurred	All	An error or warning has occurred.
0	No reason	All	No reason has been detected. The motor operation should be possible.
1	Main power supply interrupted	All	The main power supply to the Servo Drive is not turned ON.
2	No RUN input	All	The RUN command is not connected to COM.
3	Drive prohibit input is enabled	All	When Pn04 = 0 (drive prohibit input enabled): <ul style="list-style-type: none"> <li>• The Forward Drive Prohibit Input (POT) is open and the speed command is in the forward direction.</li> <li>• The Reverse Drive Prohibit Input (NOT) is open and the speed command is in the reverse direction.</li> </ul>
4	Low torque limit	All	The currently effective torque limit, Pn5E (No. 1 Torque Limit) or Pn5F (No. 2 Torque Limit), is less than 5% of the rated torque.
5	Analog torque limit input is enabled	P, S	When Pn03=0 (analog torque limit input): <ul style="list-style-type: none"> <li>• The forward analog torque limit input is negative and the speed command is in the forward direction.</li> <li>• The reverse analog torque limit input is positive and the speed command is in the reverse direction.</li> </ul>
6	IPG input is disabled	P	Pn43 = 0 (Command Pulse Prohibited Input Enabled) and the IPG input is open.
7	Frequency of command pulse input is low	P	The position command per control cycle is 1 pulse or less and the following are some of the possible causes. <ul style="list-style-type: none"> <li>• The command pulse is not input correctly.</li> <li>• The input specified in Pn40 is not connected correctly.</li> <li>• The type of input specified in Pn41 or Pn42 is not correct.</li> </ul>
8	ECRST input is enabled	P	Pn4E = 0 (Clear deviation counter when signal is closed for 100 μs or longer) and the deviation counter reset input (ECRST) is connected to COM.
9	VZERO input is enabled	S, T	Pn06 = 1 (zero-speed designation input enabled) and the Zero-speed Designation Input (VZERO) is open.
10	External speed command is low	S	The analog speed command is 0.06 V or smaller when the analog speed command is selected.
11	Internal speed command is zero	S	The internal speed command is 30 r/min or less when the internal speed command is selected.
12	Torque command is low	T	The analog torque command input (REF or PCL) is 5% or less of the rated torque.
13	Speed limit is low	T	<ul style="list-style-type: none"> <li>• Pn5B = 0 (limit speed with No. 4 Internally Set Speed) and the No. 4 Internally Set Speed (Pn56) is 30 r/min or lower.</li> <li>• Pn5B = 1 (limit speed with REF input) and the analog speed command input (REF) is 0.06 V or lower.</li> </ul>
14	Other	All	Reasons 1 to 13 do not apply, but the motor is rotating at 20 r/min or lower. (Command is low, load is heavy, load is locked, load has hit something, Servo Drive is faulty, Servomotor is faulty, etc.)

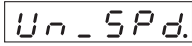

**Note** The Servomotor may rotate even if a reason number other than 0 is displayed.

## Parameter Setting Mode



### 1. Displaying Parameter Setting Mode

Key operation	Display example	Explanation
		The item set for the Default Display (Pn01) is displayed.
		Press the Data key to display Monitor Mode.
		Press the Mode key to display Parameter Setting Mode.





### 2. Setting the Parameter Number

Key operation	Display example	Explanation
		Use the Shift, Increment, and Decrement keys to set the parameter number. If the parameter number is large, the setting can be made more quickly by using the Shift key to change the digit that is being set. The decimal point will flash for the digit that can be set.

### 3. Displaying the Parameter Setting



Key operation	Display example	Explanation
		Press the Data key to display the setting.

### 4. Changing the Parameter Setting

Key operation	Display example	Explanation
		Use the Shift, Increment, and Decrement key to change the setting. The decimal point will flash for the digit that can be set.
		Press the Data key to save the new setting.



5. Returning to Parameter Setting Mode

Key operation	Display example	Explanation
		Press the Data key to return to Parameter Setting Mode.



**Precautions for Correct Use**

- ♦ Some parameters will be displayed with an “r” before the number when the display returns to the Parameter Setting Mode Display. To enable the settings that have been changed for these parameters, you must turn the power supply OFF and ON after saving the parameters to the EEPROM.
- ♦ When the setting for a parameter is saved, the new setting will be used for control. Make gradual rather than large changes when changing values for parameters that greatly affect motor operation. This is particularly true for the speed loop gain and position loop gain.
- ♦ For details on parameters, refer to *Parameters Details* on page 5-51.

## Parameter Write Mode

Settings changed in Parameter Setting Mode must be saved to EEPROM. To do so, the following procedure must be performed.

### 1. Saving Changed Settings

Key operation	Display example	Explanation
	EE SET	Press the Mode key to display Parameter Write Mode.
	EEP -.	Press the Data key to enter Parameter Write Mode.
	EEP --.	Press the Increment key for 5 s or longer.
	-----.	The bar indicator will increase.
	StArT	Writing will start. (This display will appear only momentarily.)
	FinIsh.	This display indicates a normal completion. In addition to the "Finish," either "Reset" or "Error" may be displayed. If "Reset" is displayed, writing has been completed normally, but some of the changed parameters will be enabled only after the power has been turned OFF and ON again. Turn OFF the Servo Drive power supply and then turn it ON again. "Error" is displayed if there is a writing error. Write the data again.

### 2. Returning to Parameter Write Mode

Key operation	Display example	Explanation
	EE SET	Press the Data key to return to Parameter Write Mode.





#### Precautions for Correct Use

- ♦ If a write error occurs, write the data again. If write errors continue to occur, there may be a fault in the Servo Drive.
- ♦ Do not turn OFF the power supply while writing to EEPROM. Incorrect data may be written if the power supply is turned OFF. If the power supply is turned OFF, perform the settings again for all parameters, and write the data again.
- ♦ Do not disconnect the Parameter Unit from the Servo Drive during the time from writing start ("Start") to writing completion ("Finish" or "Reset"). If the Parameter Unit is disconnected, repeat the procedure from the beginning.



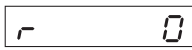

## Normal Mode Autotuning

For details on normal mode autotuning, refer to *Normal Mode Autotuning* on page 7-16. This section describes only the operating procedure.

### 1. Displaying Normal Mode Autotuning

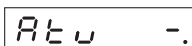
Key operation	Display example	Explanation
		The item set for the Default Display (Pn01) is displayed.
		Press the Data key to display Monitor Mode.
		Press the Mode key three times to display Normal Mode Autotuning.

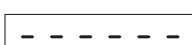
### 2. Executing Normal Mode Autotuning

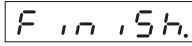
Key operation	Display example	Explanation
		Press the Data key to enter Normal Mode Autotuning.
		Press and hold the Increment key until "Start" is displayed. The bar indicator will increase when the key is pressed for 5 s or longer.
		The bar indicator will increase.
		The Servomotor will start, and normal mode autotuning will begin.
		This display indicates a normal completion. "Error" will be displayed if a tuning error has occurred.

### 3. Returning to Normal Mode Autotuning

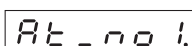
Key operation	Display example	Explanation
		Press the Data key to return to Normal Mode Autotuning.

#### Precautions for Correct Use

- For details on normal mode autotuning, refer to *Normal Mode Autotuning* on page 7-16. This section describes only the operating procedure.
- Always save each gain value changed with normal mode autotuning in the EEPROM so that the data is not lost when the power is turned OFF or for some other reason.
- If a tuning error occurs, the values for each gain will return to the values before executing the tuning.

## 6-4 Setting the Mode

### Auxiliary Function Mode

Auxiliary Function Mode includes the alarm reset, automatic offset adjustment, absolute encoder reset, and jog operation.

#### Displaying Auxiliary Function Mode

Key operation	Display example	Explanation
		The item set for the Default Display (Pn01) is displayed.
		Press the Data key to display Monitor Mode.
		Press the Mode key four times to display Auxiliary Function Mode.

## 6

### ■ Alarm Reset

#### 1. Executing Alarm Reset



Key operation	Display example	Explanation
		Press the Data key to enter Alarm Reset Mode.
		Press and hold the Increment key until "Start" is displayed. The bar indicator will increase when the key is pressed for 5 s or longer.
		The bar indicator will increase.
		Alarm reset will start.
		This display indicates a normal completion. "Error" will be displayed if the alarm could not be reset. Reset the power supply to clear the error.

#### 2. Returning to Auxiliary Function Mode

Key operation	Display example	Explanation
		Press the Data key to return to Auxiliary Function Mode.

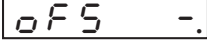

## ■ Automatic Offset Adjustment

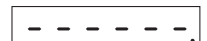
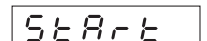
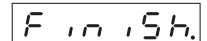
### 1. Executing Automatic Offset Adjustment

Key operation	Display example	Explanation
		Press the Data key to enter Automatic Offset Adjustment Mode.
		Press and hold the Increment key until "Start" is displayed. The bar indicator will increase when the key is pressed for 5 s or longer.
		The bar indicator will increase.
		Automatic offset adjustment will start.
		This display indicates a normal completion. "Error" will be displayed if the automatic offset adjustment could not be performed. Set a valid control mode or make the setting so that the offset value does not exceed the range for the Speed Command Offset Adjustment (Pn52), and then perform the procedure again.

**Note** Do not perform this operation if a position loop has been configured with the host system.

### 2. Returning to Auxiliary Function Mode





Key operation	Display example	Explanation
		Press the Data key to return to Auxiliary Function Mode.

#### Precautions for Correct Use

- ♦ Automatic offset adjustment cannot be performed in Position Control Mode.
- ♦ Data is not written to the EEPROM simply by performing automatic offset adjustment.  
The data must be written to the EEPROM for the results to be saved.

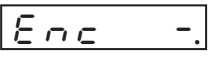
■ Absolute Encoder Reset **ABS**

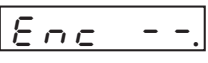
1. Executing Absolute Encoder Reset

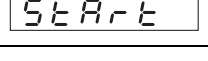
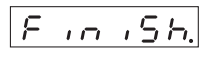
Key operation	Display example	Explanation
		Press the Data key to enter Absolute Encoder Reset Mode.
		Press and hold the Increment key until "Start" is displayed. The bar indicator will increase when the key is pressed for 5 s or longer.
		The bar indicator will increase.
		Absolute encoder reset will start.
		This display indicates a normal completion. "Error" will be displayed if the absolute encoder reset could not be performed. Check whether an unsupported encoder is connected, and then perform the procedure again.

2. Returning to Auxiliary Function Mode

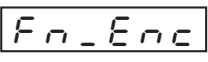





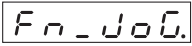

Key operation	Display example	Explanation
		Press the Data key to return to Auxiliary Function Mode.

**Precautions for Correct Use**

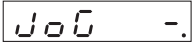
- ♦ The absolute encoder can be reset only with systems that use an absolute encoder.
- ♦ Do not disconnect the Parameter Unit from the Servo Drive until resetting the absolute encoder has completed. If the Parameter Unit is disconnected, reconnect it and make the settings from the beginning.

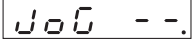
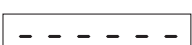
## ■ Jog Operation

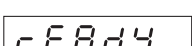
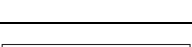
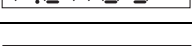
### 1. Executing Jog Operation

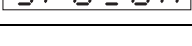
Key operation	Display example	Explanation
		Press the Increment key to display the Jog Operation Mode from the alarm reset display in Auxiliary Function Mode.
		Press the Data key to enter Jog Operation Mode.
		Press and hold the Increment key until "Ready" is displayed. The bar indicator will increase when the key is pressed for 5 s or longer.
		The bar indicator will increase.
		This completes preparations for jog operation.
		Press and hold the Shift key until "Sev_on" is displayed. The decimal point will move to the left when the key is pressed for 3 s or longer.
		
		The Servo will turn ON.
		Forward operation will be performed while the Increment key is pressed, and reverse operation will be performed while the Decrement key is pressed. The Servomotor will stop when the key is released. The speed set for the Jog Speed (Pn3D) will be used for jogging.

### 2. Returning to Auxiliary Function Mode

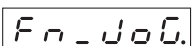
Key operation	Display example	Explanation
		Press the Data key to return to Auxiliary Function Mode. The Servo lock will be released.





## Copy Mode

In Copy Mode, user parameters set in the Servo Drive can be copied to the Parameter Unit, and user parameters stored in the Parameter Unit can be copied to the Servo Drive.



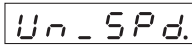

This function can be used to easily set the same user parameters for more than one Servo Drive.

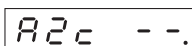
### ■ Copying from the Servo Drive to the Parameter Unit

#### 1. Displaying Copy Mode

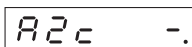
Key operation	Display example	Explanation
		The item set for the Default Display (Pn01) is displayed.
		Press the Data key to display Monitor Mode.
		Press the Mode key five times to display Copy Mode.

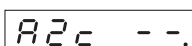
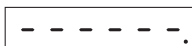
#### 2. Executing Copying

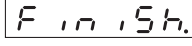
Key operation	Display example	Explanation
		Press the Data key to enter Copy Mode.
		Press and hold the Increment key until "EEPCLR" is displayed. The bar indicator will increase when the key is pressed for 3 s or longer.
		The bar indicator will increase.
	 	Initialization of the EEPROM in the Parameter Unit will start.
		This display indicates a normal completion.

#### 3. Returning to Copy Mode

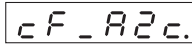
Key operation	Display example	Explanation
		Press the Data key to return to Copy Mode.

#### Precautions for Correct Use

- ♦ If "Error" is displayed before completion, repeat the procedure from the beginning. Press the Data key to clear the error.
- ♦ Do not disconnect the Parameter Unit from the Servo Drive while copying is being performed. If the Parameter Unit is disconnected, connect it and then repeat the procedure from the beginning.
- ♦ If errors are repeatedly displayed, the following may be the cause: cable disconnection, connector contact failure, incorrect operation due to noise, or EEPROM fault in the Parameter Unit.



## ■ Copying from the Parameter Unit to the Servo Drive

### 1. Displaying Copy Mode

Key operation	Display example	Explanation
		The item set for the Default Display (Pn01) is displayed.
		Press the Data key to display Monitor Mode.
		Press the Mode key five times to display Copy Mode.
		Press the Increment key to switch to the copy display for copying from the Parameter Unit to the Servo Drive.



### 2. Checking the Servo Drive Model Code

Key operation	Display example	Explanation
		Press the Data key to enter Copy Mode.
		Press and hold the Increment key until "EEP_CH" is displayed. "DIFFER" will be displayed if a different model code is entered. The bar indicator will increase when the key is pressed for 3 s or longer.
		The bar indicator will increase. The Servo Drive model code is being checked. If a different model code has been entered, refer to 3. <i>Different Model Codes</i> below to perform the procedure. If the model codes match, the display will proceed to the display in 4. <i>Executing Copying</i> .

### 3. Different Model Codes

Key operation	Display example	Explanation
		The decimal point will move to the left when the Shift key is pressed for 3 s or longer.
		The model codes are being matched.
		Press the Data key to cancel copying before completion.

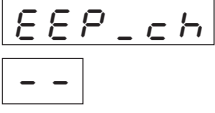
4. Executing Copying

Key operation	Display example	Explanation
		Writing user parameters to the EEPROM of the Servo Drive will start.
		This display indicates a normal completion.

5. Returning to Copy Mode

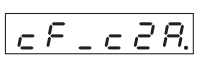
Key operation	Display example	Explanation
		Press the Data key to return to Copy Mode.

**Precautions for Correct Use**

- ◆ If “Error” is displayed before completion, repeat the procedure from the beginning.
- ◆ Press the Data key to clear the error.
- ◆ If errors are repeatedly displayed, the following may be the cause: cable disconnection, connector contact failure, incorrect operation due to noise, or EEPROM fault in the Parameter Unit.
- ◆ Do not disconnect the Parameter Unit from the Servo Drive while copying is being performed. If the Parameter Unit is disconnected, incorrect data may be written and the data may be corrupted. Copy the user parameters again from the source Servo Drive to the Parameter Unit, and then copy the user parameters from the Parameter Unit to the other Servo Drive.

---

## 6-5 Trial Operation

---

When you have finished installation, wiring, and switch settings and have confirmed that status is normal after turning ON the power supply, perform trial operation. The main purpose of trial operation is to confirm that the servo system is electrically correct.

If an error occurs during the trial operation, refer to *Chapter 8 Troubleshooting* to eliminate the cause. Then check for safety, and then retry the trial operation.

### Preparation for Trial Operation

#### ■ Checks before Trial Operation

Check the following items before starting trial operation.

##### Wiring

- Make sure that all wiring is correct, especially the power supply input and motor output.
- Make sure that there are no short-circuits. Check the ground for short-circuits as well.
- Make sure that there are no loose connections.

##### Power Supply Voltage

- Make sure that the voltage corresponds to the rated voltage.

##### Motor Installation

- Make sure that the Servomotor has been securely installed.

##### Disconnection from Mechanical System

- If necessary, make sure that the Servomotor has been disconnected from the mechanical system.

##### Brake

- Make sure that the brake has been released.

### Trial Operation in Position Control Mode

1. Connect connector CN1.
2. Input power (12 to 24 VDC) for the control signals (+24VIN, COM).
3. Turn ON the power supply to the Servo Drive.
4. Confirm that the parameters are set to the standard settings.
5. Set the outputs from the host device to agree with the Command Pulse Mode (Pn42).
6. Write the parameters to EEPROM and then turn OFF the power supply and turn it ON again.
7. Connect the RUN Command Input (RUN: CN1 pin 29) to COM (CN1 pin 41).  
Servo ON status will be entered and the Servomotor will be activated.
8. Input a low-frequency pulse signal from the host device to start low-speed operation.
9. Check the Servomotor rotation speed in Monitor Mode.

Check to see if the Servomotor is rotating at the specified speed and to see if the Servomotor stops when the command pulses are stopped.

## Trial Operation in Speed Control Mode

1. Connect connector CN1.
2. Input power (12 to 24 VDC) for the control signals (+24VIN, COM).
3. Turn ON the power supply to the Servo Drive.
4. Confirm that the parameters are set to the standard settings.
5. Connect the RUN Command Input (RUN: CN1 pin 29) to COM (CN1 pin 41). Servo ON status will be entered and the Servomotor will be activated.
6. Close the Zero-speed Designation Input (VZERO) and gradually increase the DC voltage across the Speed Command Input (REF: CN1 pin 14) and AGND (CN1 pin 15) from 0 V. Check to see if the Servomotor rotates.
7. Check the Servomotor rotation speed in Monitor Mode.

Check to see if the Servomotor is rotating at the specified speed and to see if the Servomotor stops when the command pulses are stopped. Use the following parameters to change the Servomotor rotation speed or direction.

- Pn50: Speed Command Scale
- Pn51: Command Speed Rotation Direction Switch

## Trial Operation in Torque Control Mode

1. Connect connector CN1.
2. Input power (12 to 24 VDC) for the control signals (+24VIN, COM).
3. Turn ON the power supply to the Servo Drive.
4. Confirm that the parameters are set to the standard settings.
5. Set a low speed in the No. 4 Internally Set Speed (Pn56).
6. Connect the RUN Command Input (RUN: CN1 pin 29) to COM (CN1 pin 41). Servo ON status will be entered and the Servomotor will be activated.
7. Apply a positive or negative DC voltage across the Torque Command Input (TREF1: CN1 pin 14) and AGND (CN1 pin 15). Check to see if the Servomotor rotates according to the direction (forward/reverse) set in Pn56.

Use the following parameters to change the amount of the torque, direction of the torque, or speed limit for the command voltage.

- Pn56: No. 4 Internally Set Speed (default value: 50 r/min)
- Pn5C: Torque Command Scale
- Pn5D: Torque Output Direction Switch

# Chapter 7

## Adjustment Functions

7-1	Gain Adjustment.....	7-1
	Purpose of the Gain Adjustment .....	7-1
	Gain Adjustment Methods.....	7-2
	Gain Adjustment Procedure .....	7-3
7-2	Realtime Autotuning .....	7-4
	Realtime Autotuning Setting Method .....	7-5
	Operating Procedure.....	7-6
	Fit Gain Function.....	7-7
	Adaptive Filter .....	7-11
	Automatically Set Parameters.....	7-12
7-3	Normal Mode Autotuning .....	7-14
	Normal Mode Autotuning Setting Method .....	7-15
	Automatically Set Parameters.....	7-16
7-4	Disabling the Automatic Gain Adjustment Function .....	7-19
	Disabling Realtime Autotuning.....	7-19
	Disabling the Adaptive Filter .....	7-20
7-5	Manual Tuning .....	7-21
	Basic Settings .....	7-21
	Gain Switching Function .....	7-26
	Machine Resonance Control.....	7-30
	Automatic Gain Setting .....	7-32
	Instantaneous Speed Observer .....	7-33
	Damping Control .....	7-35

# 7-1 Gain Adjustment

OMNUC G-Series Servo Drives provide realtime autotuning and normal mode autotuning functions. With these functions, gain adjustments can be made easily even by those who use a servo system for the first time. If you cannot obtain desired responsiveness with autotuning, use manual tuning.

## Purpose of the Gain Adjustment

The Servomotor must operate in response to commands from the host system with minimal time delay and maximum reliability. The gain is adjusted to bring the actual operation of the Servomotor as close as possible to the operations specified by the commands, and to maximize the performance of the machine.

Example: Ball screw

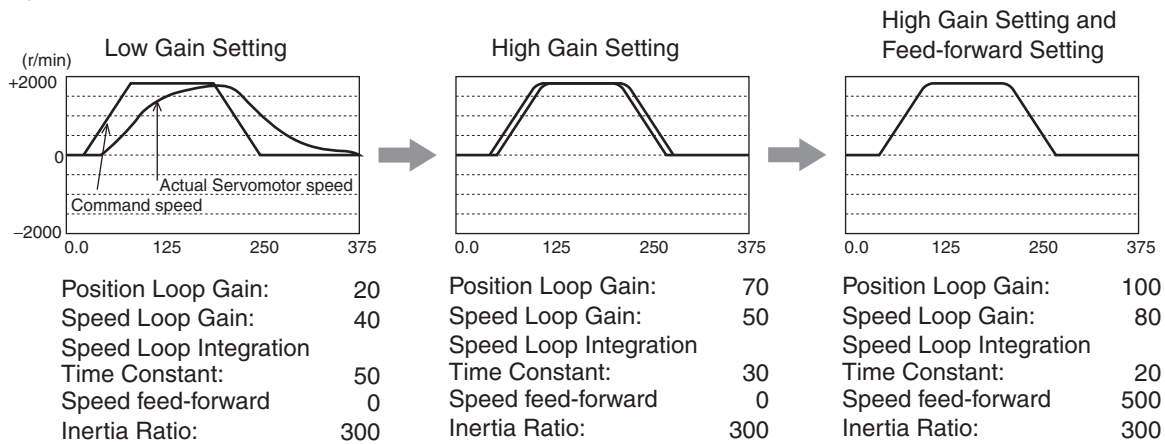

## Gain Adjustment Methods

Function		Explanation	Reference page
Automatic adjustment	Realtime autotuning	Realtime autotuning estimates the load inertia of the mechanical system in realtime and automatically sets the optimal gain according to the estimated load inertia.	7-4
	Fit gain function	The fit gain function automatically searches for the appropriate rigidity setting by repeating input of an operation with a specified pattern to automatically make the rigidity setting for realtime autotuning when position control is performed.	7-7
	Adaptive filter	The adaptive filter reduces resonance point vibration by estimating the resonance frequency from the vibration component that appears in the Servomotor speed during actual operation and automatically sets the coefficient of the notch filter, which removes the resonance component from the torque command.	7-11
	Normal Mode Autotuning	Normal mode autotuning automatically sets the appropriate gain by operating the Servomotor with the command pattern automatically generated by the Servo Drive and estimating the load inertia from the torque required at that time.	7-14
	Automatic gain adjustment reset	This function disables the default settings for realtime autotuning and the adaptive filter.	7-19
Manual adjustment	Manual tuning (basic)	Manual tuning is performed if autotuning cannot be executed due to restrictions on the control mode or load conditions or if ensuring the maximum responsiveness to match each load is required.	
	Basic procedure	Position control mode adjustment	7-22
		Speed control mode adjustment	7-24
		Torque control mode adjustment	7-25
	Gain switching	Gain switching can be used with internal data or external signals to perform such actions as reducing vibration at stopping, shortening stabilization time, and improving command follow-up.	7-26
	Machine resonance suppression	It is sometimes not possible to set the gain high because of vibration or sound due to resonance caused by shaft contortion when the machine rigidity is low. In these cases, two types of filters can be used to suppress resonance.	7-30
	Automatic gain setting	This function initializes control parameters and gain switching parameters to settings that match the normal mode autotuning rigidity parameters before manual tuning is performed.	7-32
	Manual tuning (application)	The following application functions can be used to further improve performance if the specifications cannot be satisfied using basic adjustment.	
	Instantaneous speed observer	The instantaneous speed observer both increases responsiveness and reduces vibration at stopping by estimating the Servomotor speed using a load model and improving the speed detection accuracy.	7-33
Damping control	Damping control reduces vibration by removing the vibration frequency component from the command when the end of mechanisms or devices vibrates.	7-35	

**Note 1.** Take sufficient care for safety.

**Note 2.** If oscillation occurs (e.g., abnormal sound or vibration), immediately turn OFF the power supply or let the servo OFF status occur.

**Gain Adjustment Procedure**

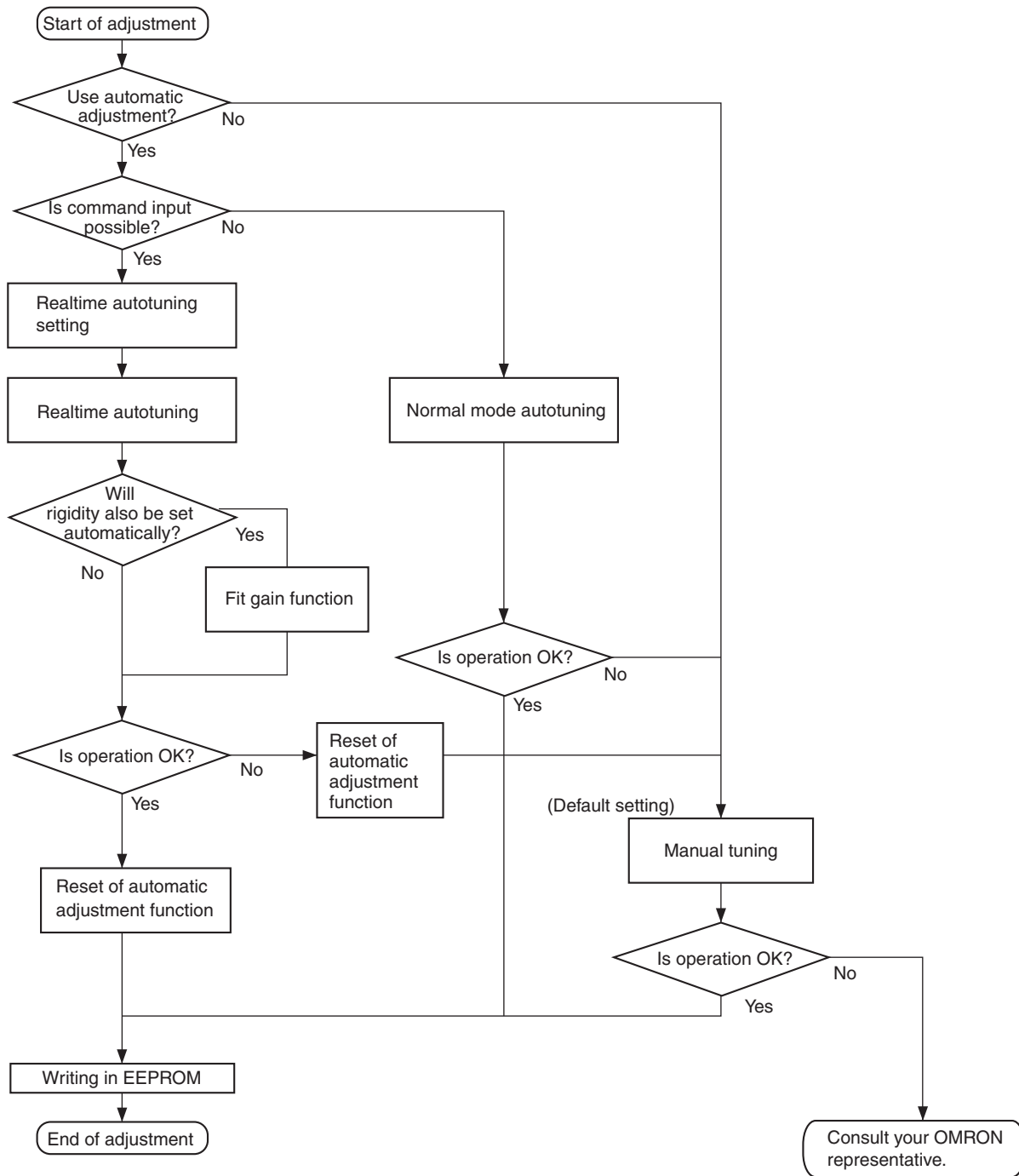

7 Adjustment Functions

**Gain Adjustment and Machine Rigidity**

Do the following to increase the machine rigidity:

- Install the machine on a secure base so that it does not wobble.
- Use couplings that have a high rigidity, and that are designed for servo systems.
- Use a wide timing belt, and use a tension within the allowable axial load for the Servomotor.
- Use gears with small backlash.

The specific vibration (resonance frequency) of the mechanical system has a large impact on the gain adjustment. The servo system responsiveness cannot be set high for machines with a low resonance frequency (low machine rigidity).



## 7-2 Realtime Autotuning

Realtime autotuning estimates the load inertia of the machine in realtime, and automatically sets the optimal gain according to the estimated load inertia.

Realtime autotuning can be applied to all control modes.

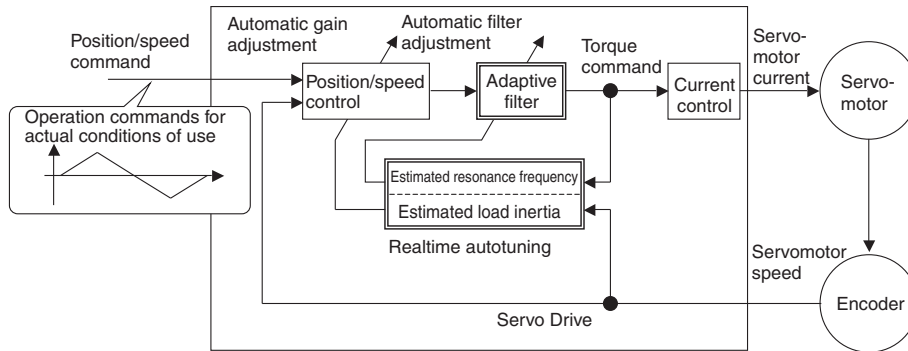

### Precautions for Correct Use

- Realtime autotuning may not function properly under the conditions described in the following table. If realtime autotuning does not function properly, use normal mode autotuning or manual tuning.

	Conditions under which realtime autotuning does not function properly
Load inertia	<ul style="list-style-type: none"> <li>• If the load inertia is too small or too large compared with the rotor inertia (i.e., less than 3 times, more than 20 times, or more than the applicable load inertia ratio).</li> <li>• If the load inertia changes quickly, i.e., in less than 10 seconds.</li> </ul>
Load	<ul style="list-style-type: none"> <li>• If the machine rigidity is extremely low.</li> <li>• If there is backlash or play in the system.</li> </ul>
Operating pattern	<ul style="list-style-type: none"> <li>• If the speed is continuously run at a low speed below 100 r/min.</li> <li>• If the acceleration/deceleration gradually changes at less than 2,000 r/min in 1 s.</li> <li>• If the acceleration/deceleration torque is too small compared with the unbalanced load and the viscous friction torque.</li> <li>• If a speed of 100 r/min or an acceleration/deceleration of 2,000 r/min/s does not continue for at least 50 ms.</li> </ul>

## Realtime Autotuning Setting Method

1. Stop the Servomotor (i.e., turn the servo OFF).
2. Set the Realtime Autotuning Mode Selection (Pn21) to 1 to 7.

The default setting is 1.

Setting	Realtime Autotuning	Degree of change in load inertia during operation
0	Not used	---
1	Normal mode	No change in load inertia
2		Gradual changes in load inertia
3		Sudden changes in load inertia
4	Vertical axis mode	No change in load inertia
5		Gradual changes in load inertia
6		Sudden changes in load inertia
7	No gain switching mode	No change in load inertia

When the degree of load inertia change is high, set the value to 3 or 6.

Use a setting of 4 to 6 when the vertical axis is used.

Use setting 7 if vibration occurs due to gain switching.

3. Set the Realtime Autotuning Machine Rigidity Selection (Pn22) to 0 or a low value.
4. Turn the servo ON, and operate the machine as normally.
5. To increase system responsiveness, gradually increase the setting of the Realtime Autotuning Machine Rigidity Selection (Pn22).  
If the machine produces unusual noise or oscillation, return the Realtime Autotuning Machine Rigidity Selection to a low value (e.g., 0 to 3) immediately.
6. Write data to the EEPROM if the results are to be saved.

## Operating Procedure

Insert the Parameter Unit connector into CN3B of the Servo Drive and turn ON the Servo Drive power supply.

r 0

### Setting Parameter Pn21

Press the  key.

Un\_SpD

Press the  key.

Pn\_ 00.



Select the number of the parameter to be set by using the  and  keys.

Pn\_ 21.

(Pn21 is selected in this example.)

Press the  key.

1.

Change the value by using the  and  keys.

Press the  key.

Pn\_ 21.

### Setting Parameter Pn22

Select Pn22 by using the  key.

Pn\_ 22.

Press the  key.

4

(Default setting)

Increase the value by using the  key.

Decrease the value by using the  key.

Press the  key.

### Writing to EEPROM

Press the  key.

EE\_SEt.

Press the  key.

EEP -.

The bars as shown in the figure on the right will increase when the  key is pressed down for approx. 5 s.

EEP --.

-----.

Writing will start (momentary display).

StArT

End

FinIsh. rESEt. Error.

Writing completed.

Writing error occurred.

## Fit Gain Function

OMNUC G-Series products include a fit gain function that automatically sets the rigidity to match the device when realtime autotuning is used at position control. A fully automatic search is performed for the optimal rigidity setting by repeating a specified reciprocating operation with position control.

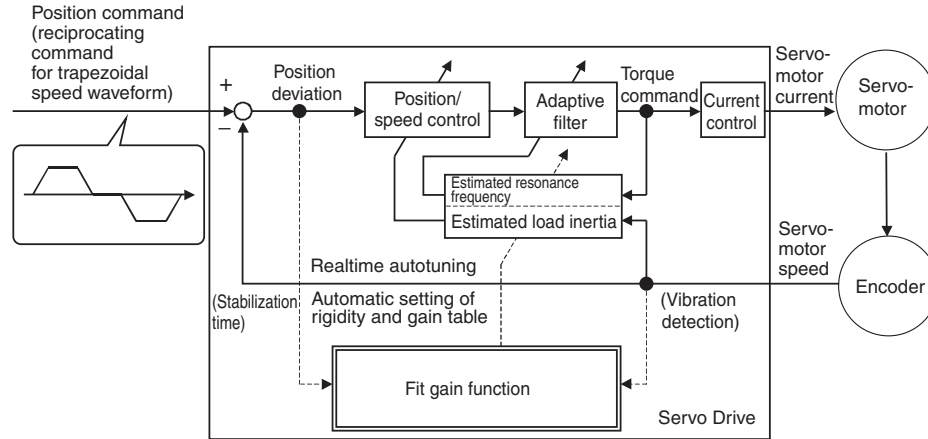

### Precautions for Correct Use

- To be applicable, this function must satisfy the following conditions in addition to the conditions for realtime autotuning.

	Conditions under which the fit gain functions properly
Realtime autotuning operation	<ul style="list-style-type: none"> <li>• The realtime autotuning operates normally.</li> <li>• The Servo is ON.</li> <li>• Pn21= 1 to 6. (Operation is not possible if Pn21 is 0 or 7.)</li> </ul>
Adaptive filter	<ul style="list-style-type: none"> <li>• The adaptive filter is enabled. Pn23 = 1: Enabled</li> </ul>
Control mode	<ul style="list-style-type: none"> <li>• The control mode is position control. Pn02 = 0: Position control Pn02 = 3: First control mode for position/speed control Pn02 = 4: First control mode for position/torque control</li> </ul>
Operating pattern	<ul style="list-style-type: none"> <li>• The position command is for reciprocating operation.</li> <li>• The time per position command is at least 50 ms.</li> <li>• The minimum frequency for the position command is 1 kpps. (Required to determine the start and end of the command.)</li> </ul>

- In addition to the precautions for realtime autotuning, be aware of the following conditions under which operation may not be performed correctly. If that occurs, use normal realtime autotuning.

	Conditions under which the fit gain does not function properly
Operating pattern	<ul style="list-style-type: none"> <li>• One position command is too short, i.e., less than two revolutions.</li> <li>• Positioning is not completed after the position command is completed and before the next position command starts.</li> <li>• The acceleration/deceleration is sudden, i.e., 3,000 r/min/0.1 s.</li> </ul>

Before starting the fit gain function, make the following settings using the fit gain window on the front panel, parameter setting mode, the Parameter Unit, or CX-Drive.

Parameter	Setting	Remarks
Realtime Autotuning Mode Selection (Pn21)	Make one of the following settings. 1: Normal mode (almost no change) 2: Normal mode (gradual change) 3: Normal mode (sudden change) 4: Vertical axis mode (almost no change) 5: Vertical axis mode (gradual change) 6: Vertical axis mode (sudden change)	The parameters at the left can also be set using the execution display in the fit gain window on the front panel.
Realtime Autotuning Machine Rigidity Selection (Pn22)	0: Realtime rigidity No. 0	
Adaptive Filter Selection (Pn23)	1: Enabled	
Positioning Completion Range (Pn60)	17-bit encoder: 20 pulses min. 2,500 P/r encoder: 10 pulses min.	

### ■ Operating Procedure

1. **Set the front panel display to the execution display of the fit gain window.**  
(Refer to the *Front Panel Display Example* on page 7-9 for information on using the front panel.)
2. **With the dot at the far right flashing, decrease the rigidity to 0, and press the Decrement key on the front panel for 3 s min. to start the fit gain function.**
3. **Input a position command that satisfies the operating pattern conditions given in *Precautions for Correct Use under Fit Gain Function* on page 7-7.**

If the fit gain is completed normally, `FINISH` will be displayed, and `ERROR` will be displayed if it is completed with an error. (The `ERROR` display can be cleared using the keys.)

- Time is required for the change to be made for fit gain operation. It may take approximately 2 or 3 min. depending on the equipment configuration, which may require up to approximately 50 reciprocating operations. Normally, the fit gain will be completed when the optimal realtime rigidity number is found.
- `ERROR` will be displayed in the following cases.
  - The INP signal becomes unstable, or a realtime rigidity number without small vibration is not found.
  - The keys on the front panel are used while fit gain is operating or the applicable conditions are not satisfied.

■ Operating Procedure

Front Panel Display Example

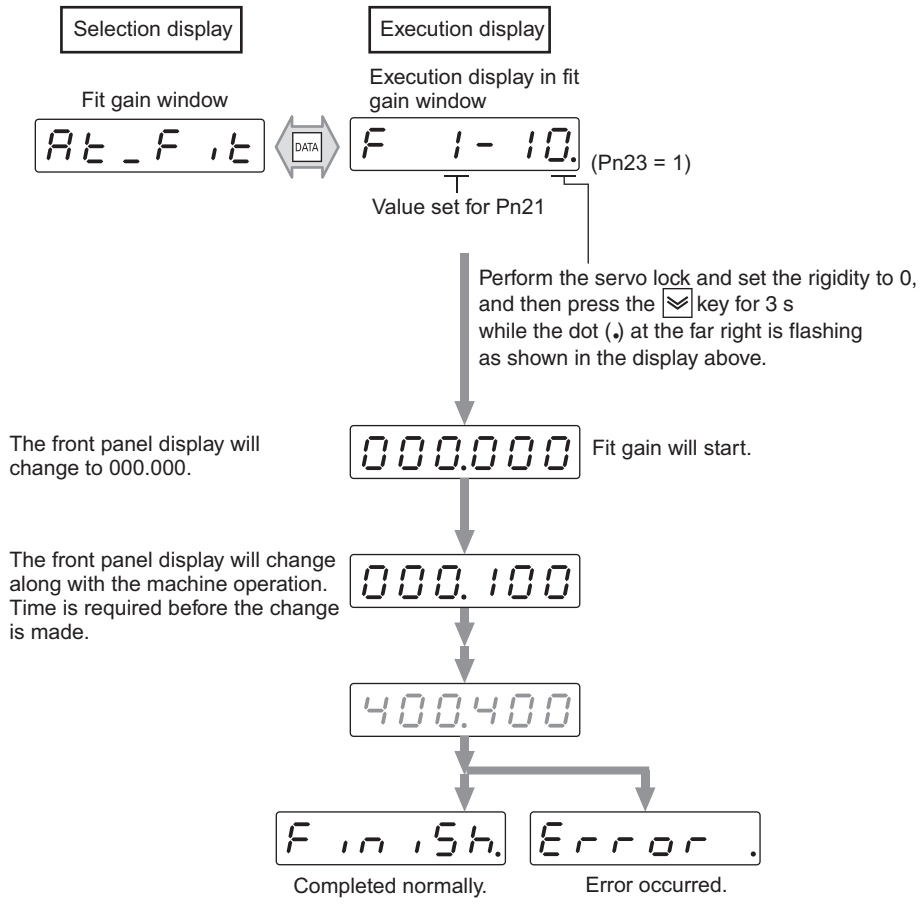

■ Fit Gain Results

If fit gain is completed normally, `Finish` will be displayed, and `Error` will be displayed if it is completed with an error. To apply the results obtained from fit gain after resetting the power supply, write the data to the EEPROM. (Refer to the following description.)

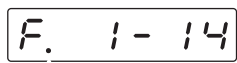

Move the dot (.) to this point using the [Left Arrow] key, and press the [OK] key for 3 s min. to write the present settings to the EEPROM.

## ■ Automatically Set Parameters

The following parameters are set automatically.

Parameter No.	Parameter name
Pn10	Position Loop Gain
Pn11	Speed Loop Gain
Pn12	Speed Loop Integration Time Constant
Pn13	Speed Feedback Filter Time Constant
Pn14	Torque Command Filter Time Constant
Pn18	Position Loop Gain 2
Pn19	Speed Loop Gain 2
Pn1A	Speed Loop Integration Time Constant 2
Pn1B	Speed Feedback Filter Time Constant 2
Pn1C	Torque Command Filter Time Constant 2
Pn20	Inertia Ratio
Pn22	Realtime Autotuning Machine Rigidity Selection

The following parameters are set automatically. (The settings will not change even if realtime autotuning is executed.)

Parameter No.	Parameter name	Set value
Pn15	Feed-forward Amount	300
Pn16	Feed-forward Command Filter	50
Pn27	Instantaneous Speed Observer Setting	0
Pn30	Gain Switching Input Operating Mode Selection	1
Pn31	Control Gain Switch 1 Setting	10
Pn32	Gain Switch 1 Time 1	30
Pn33	Gain Switch 1 Level Setting	50
Pn34	Gain Switch 1 Hysteresis Setting	33
Pn35	Position Loop Gain Switching Time	20
Pn36	Control Gain Switch 2 Setting	0

### Precautions for Correct Use

- Some degree of noise or vibration may occur during fit gain operation, but this is normally not a problem because the gain is lowered automatically. If the noise or vibration continues, however, press any key on the front panel to cancel the fit gain operation.

## Adaptive Filter

The adaptive filter reduces resonance point vibration by estimating the resonance frequency from the vibration component that appears in the Servomotor speed during actual operation, and automatically sets the coefficient of the notch filter. This removes the resonance component from the torque command.

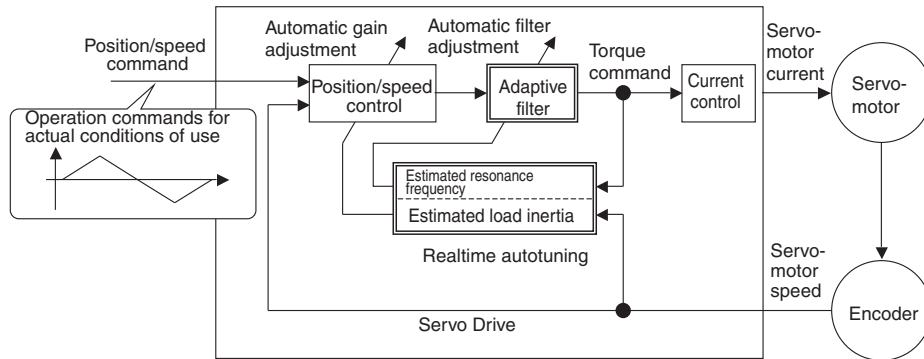

### Precautions for Correct Use

- The adaptive filter operates under the following conditions.

Conditions under which the adaptive filter operates	
Control mode	<ul style="list-style-type: none"> <li>• The control mode is not torque control.</li> </ul>

- The adaptive filter may not operate correctly under the following conditions. If it does not, take measures against resonance by following the manual adjustment procedure using Notch Filter 1 (Pn1D/1E) or Notch Filter 2 (Pn28 to 2A).
- Refer to *Machine Resonance Control* on page 7-30 for details on notch filters.
- Adaptive filter may not operate correctly under the following conditions.

Conditions under which the adaptive filter does not function properly	
Resonance points	<ul style="list-style-type: none"> <li>• If the resonance frequency is 300 Hz or lower.</li> <li>• If the resonance peak or control gain is low, and the Servomotor speed is not affected by it.</li> <li>• If there are multiple points of resonance.</li> </ul>
Load	<ul style="list-style-type: none"> <li>• If the Servomotor speed with high-frequency components changes due to backlash or other non-linear elements.</li> </ul>
Command pattern	<ul style="list-style-type: none"> <li>• If the acceleration/deceleration suddenly changes, i.e. 3,000 r/min or more in 0.1 s.</li> </ul>

### Operating Procedure

#### 1. Set the Adaptive Filter Selection (Pn23) to 1.

The adaptive filter will be enabled.

Setting	Adaptive filter	Adaptive operation
0	Disabled	---
1	Enabled	Yes
2		Yes (hold)

Set the Adaptive Filter Selection to 2 if the resonance point may not have changed when the adaptive operation is completed (i.e., Pn2F does not change).

#### 2. Write the data to the EEPROM if the results are to be saved.



**Precautions  
for Correct Use**

- An unusual noise or vibration may occur until the adaptive filter stabilizes after startup, immediately after the first servo ON, or when the Realtime Autotuning Machine Rigidity Selection (Pn22) is increased, but this is not a problem if it disappears right away. If the unusual noise or vibration, however, continues for three or more reciprocating operations, take one or more of the following measures.
  - Write the parameters used during normal operation to the EEPROM.
  - Lower the Realtime Autotuning Machine Rigidity Selection (Pn22).
  - Disable the adaptive filter by setting the Adaptive Filter Selection (Pn23) to 0 (resetting the inertia estimation and the adaptive operation).
  - Manually set the notch filter.
- Once unusual noise or vibration occurs, the Adaptive Filter Table Number Display (Pn2F) may have changed to an extreme value. In this case, also take the measures described above.
- The Adaptive Filter Table Number Display (Pn2F) is written to the EEPROM every 30 minutes, and when the power supply is turned OFF and turned ON again, this data is used as the initial values for the adaptive operation.
- The adaptive filter is normally disabled when torque control is performed, but the adaptive filter frequency used in the control mode before switching will be held if torque control has been selected by setting the Control Mode Selection (Pn02) to 4 or 5.

**Automatically Set Parameters**

The following parameters are set automatically.

Parameter No.	Parameter name
Pn10	Position Loop Gain
Pn11	Speed Loop Gain
Pn12	Speed Loop Integration Time Constant
Pn13	Speed Feedback Filter Time Constant
Pn14	Torque Command Filter Time Constant
Pn18	Position Loop Gain 2
Pn19	Speed Loop Gain 2
Pn1A	Speed Loop Integration Time Constant 2
Pn1B	Speed Feedback Filter Time Constant 2
Pn1C	Torque Command Filter Time Constant 2
Pn20	Inertia Ratio

## 7-2 Realtime Autotuning

The settings for the following parameters are automatically set and cannot be changed. (The settings will not change even if realtime autotuning is executed.)

Parameter No.	Parameter name	Set value
Pn15	Feed-forward Amount	300
Pn16	Feed-forward Command Filter	50
Pn27	Instantaneous Speed Observer Setting	0
Pn30	Gain Switching Input Operating Mode Selection	1
Pn31	Control Gain Switch 1 Setting	10
Pn32	Gain Switch 1 Time	30
Pn33	Gain Switch 1 Level Setting	50
Pn34	Gain Switch 1 Hysteresis Setting	33
Pn35	Position Loop Gain Switching Time	20
Pn36	Control Gain Switch 2 Setting	0

**Note 1.** Parameters that are automatically set cannot be changed if realtime autotuning is enabled.

**Note 2.** Pn31 is 10 when position control is used and the Realtime Autotuning Mode Selection (Pn21) is set to 1 to 6. Otherwise, it is 0.

### Precautions for Correct Use

- Unusual noise or vibration may occur until the load inertia is estimated or the adaptive filter stabilizes after startup, immediately after the first servo turns ON, or when the Realtime Autotuning Machine Rigidity Selection (Pn22) is increased. This is not a problem if it disappears right away. If the unusual noise or vibration, however, continues for three or more reciprocating operations, take the following measures in any order you can.
  - Write the parameters used during normal operation to the EEPROM.
  - Lower the Realtime Autotuning Machine Rigidity Selection (Pn22).
  - Manually set the notch filter.
- Once unusual noise or vibration occurs, the Inertia Ratio (Pn20) may have changed to an extreme value. In this case, also take the measures described above.
- Out of the results of realtime autotuning, the Inertia Ratio (Pn20) is automatically saved to the EEPROM every 30 minutes. Realtime autotuning will use this saved data as the default value when the power is turned OFF and turned ON again.
- The Instantaneous Speed Observer Setting (Pn27) will automatically be disabled (0) if realtime autotuning is enabled.

# 7-3 Normal Mode Autotuning

Normal mode autotuning operates the Servomotor according to command patterns automatically created in the Servo Drive, then estimates the load inertia based on the torque required at that time and automatically sets the appropriate gain.

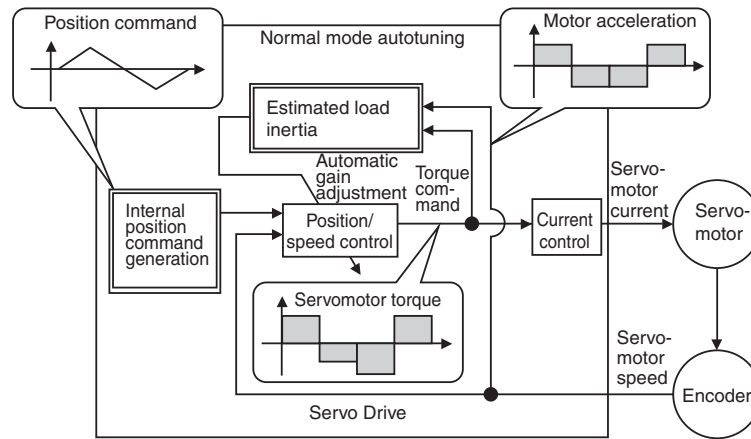

**Precautions for Correct Use**

- Normal mode autotuning operates under the following conditions.

Conditions under which normal mode autotuning operates	
Control mode	All control modes can be used.
Others	<ul style="list-style-type: none"> <li>• The servo is ON.</li> <li>• The deviation counter reset signal is not input.</li> </ul>

**Note** Set the Torque Limit Selection (Pn03) to 1. Operation may be incorrect if the setting is not 1.

- Normal mode autotuning may not function properly under the conditions described in the following table. If normal mode autotuning does not function properly, use manual tuning.

Conditions under which normal mode autotuning does not function properly	
Load inertia	<ul style="list-style-type: none"> <li>• If the load inertia is too small or too large compared with the rotor inertia (i.e., less than 3 times, more than 20 times, or more than the applicable load inertia ratio).</li> <li>• If the load inertia changes.</li> </ul>
Load	<ul style="list-style-type: none"> <li>• If the machine rigidity is extremely low.</li> <li>• If there is backlash or play in the system.</li> </ul>

**Note 1.** A tuning error will occur if an error occurs, the servo turns OFF, the main power supply is turned OFF, drive prohibit is enabled, or a deviation counter reset occurs while normal mode autotuning is in operation.

**Note 2.** If normal mode autotuning is executed, and the load inertia cannot be estimated, the gain will remain the same as it was before normal mode autotuning.

**Note 3.** When normal mode autotuning is being executed, the Servomotor output torque can be output to the maximum set in the No. 1 Torque Limit (Pn5E) parameter.

**Note 4.** Take sufficient care to ensure safety. If vibration occurs, immediately turn OFF the power supply or the servo and return the gain to the default by using the parameter settings.

### ■ Normal Mode Autotuning Operation

- Normal mode autotuning sets the responsiveness with the machine rigidity number.

#### Machine Rigidity Numbers

The degree of rigidity for the machine used is set to a number from 0 to F. The higher the rigidity of the machine, the higher the rigidity number and gain that can be set. Normally, start with a low rigidity number, increase the number in sequence while repeating normal mode autotuning, and stop before oscillation, unusual noise, or vibration occurs.

- The operating pattern set in the Autotuning Operation Setting (Pn25) is repeated for up to five cycles. The operating acceleration doubles each cycle starting with the third cycle. Depending on the load, operation may end before completing five cycles or the operating acceleration may not change. This is not an error.

### Normal Mode Autotuning Setting Method

1. **Set the operating pattern using the Autotuning Operation Setting (Pn25) parameter.**
2. **Move the load to a safe position even if the Servomotor performs the operating pattern set in Pn25.**
3. **Prohibit the command.**
4. **Turn the servo ON.**
5. **Start normal mode autotuning.**  
Start normal mode autotuning from the front panel or by using CX-Drive. Refer to *Front Panel Display Example* on page 7-9 for information on using the front panel.
6. **Adjust the machine rigidity for the desired responsiveness at a level where vibration does not occur.**
7. **If there are no problems with the results, write the data to the EEPROM.**

## Automatically Set Parameters

### Normal Mode Autotuning

Parameter No.	Parameter name	Rigidity No.															
		0	1	2	3	4	5	6	7	8	9	A	B	C	D	E	F
Pn10	Position Loop Gain	12	32	39	48	63	72	90	108	135	162	206	251	305	377	449	557
Pn11	Speed Loop Gain	9	18	22	27	35	40	50	60	75	90	115	140	170	210	250	310
Pn12	Speed Loop Integration Time Constant	62	31	25	21	16	14	12	11	9	8	7	6	5	4	4	3
Pn13	Speed Feedback Filter Time Constant	0	0	0	0	0	0	0	0	0	0	0	0	0	0	0	0
Pn14	Torque Command Filter Time Constant *2	253	126	103	84	65	57	45	38	30	25	20	16	13	11	10	10
Pn15	Feed-forward Amount	300	300	300	300	300	300	300	300	300	300	300	300	300	300	300	300
Pn16	Feed-forward Command Filter	50	50	50	50	50	50	50	50	50	50	50	50	50	50	50	50
Pn18	Position Loop Gain 2	19	38	46	57	73	84	105	126	157	188	241	293	356	440	524	649
Pn19	Speed Loop Gain 2	9	18	22	27	35	40	50	60	75	90	115	140	1170	210	250	310
Pn1A	Speed Loop Integration Time Constant 2	999	999	999	999	999	999	999	999	999	999	999	999	999	999	999	999
Pn1B	Speed Feedback Filter Time Constant 2	0	0	0	0	0	0	0	0	0	0	0	0	0	0	0	0
Pn1C	Torque Command Filter Time Constant 2 *2	253	126	103	84	65	57	45	38	30	25	20	16	13	11	10	10
Pn20	Inertia Ratio	Estimated load inertia ratio															
Pn27	Instantaneous Speed Observer Setting	0	0	0	0	0	0	0	0	0	0	0	0	0	0	0	0
Pn30	Gain Switching Input Operating Mode Selection	1	1	1	1	1	1	1	1	1	1	1	1	1	1	1	1
Pn31	Control Gain Switch 1 Setting *1	10	10	10	10	10	10	10	10	10	10	10	10	10	10	10	10
Pn32	Gain Switch 1 Time	30	30	30	30	30	30	30	30	30	30	30	30	30	30	30	30
Pn33	Gain Switch 1 Level Setting	50	50	50	50	50	50	50	50	50	50	50	50	50	50	50	50
Pn34	Gain Switch 1 Hysteresis Setting	33	33	33	33	33	33	33	33	33	33	33	33	33	33	33	33
Pn35	Position Loop Gain Switching Time	20	20	20	20	20	20	20	20	20	20	20	20	20	20	20	20
Pn36	Control Gain Switch 2 Setting	0	0	0	0	0	0	0	0	0	0	0	0	0	0	0	0

• The parameters Pn15, Pn16, Pn1A, Pn30, and Pn32 to Pn36 are set to fixed values. For normal mode autotuning, the default rigidity is 2.

\*1. The value is 10 for position control and 0 for speed and torque control.

\*2. The lower limit is set to 10 if a 17-bit encoder is used and to 25 if a 2,500-pulse/revolution encoder is used.

## ■ Front Panel Operating Procedure

### 1. Switch to the Normal Mode Autotuning from the Monitor Mode.

Press the Data key and then press the Mode key three times to change the mode.  
For details, refer to *Normal Mode Autotuning* on page 6-20.

Servomotor rotation speed display (default display)

### 2. Input the machine rigidity number using the Increment and Decrement keys.

Cannot be set to 0 when using the Parameter Unit.

Machine rigidity No.

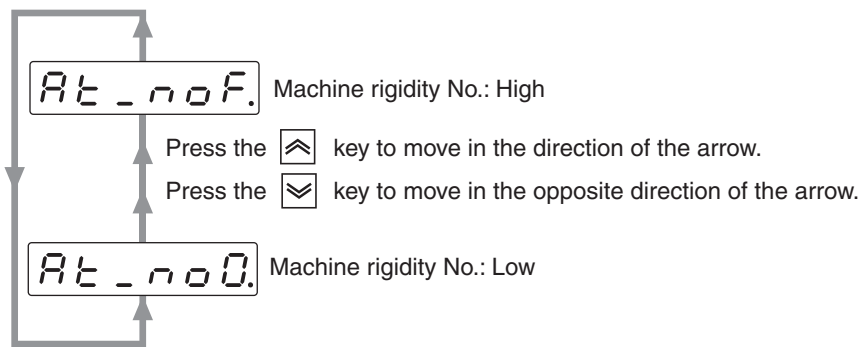

Drive system	Machine rigidity No.
Ball screw direct coupling	6 to C
Ball screw and timing belt	4 to A
Timing belt	2 to 8
Gears, rack and pinion drives	2 to 8
Machines with low rigidity, etc.	0 to 4

### 3. Press the Data key to enter the Monitor/Run Mode.

### 4. Press and hold the Increment key until the display changes to .

The Servo will be ON for pin 29 of connector CN1.

**5. Press the Increment key for approx. 3 s.**

The bar indicator will increase as shown in the following figure.

The Servomotor will start to rotate.

For a period of approximately 15 s, the Servomotor will make two revolutions in the forward/reverse direction, which will comprise one cycle and will be repeated up to five times. There is no problem if operation ends before five cycles have been completed.

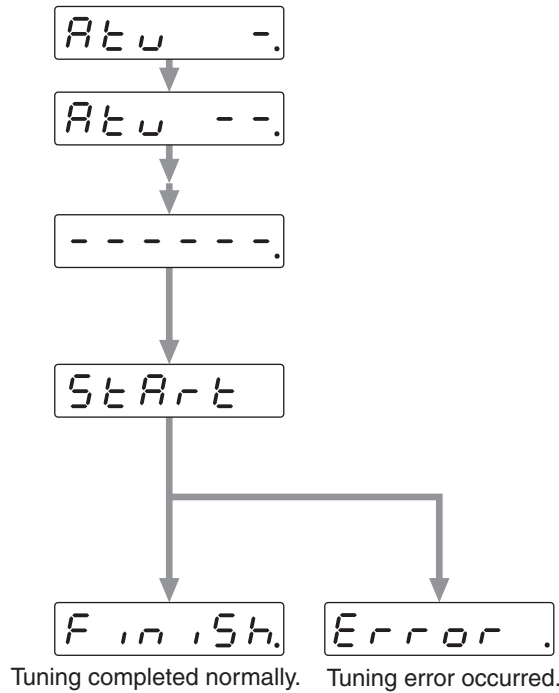

**6. Write the data to the EEPROM so that the gain values are not lost when the power supply is shut off.**

- Do not perform normal mode autotuning with the Servomotor or Servo Drive alone. The Inertia Ratio (Pn20) will become 0.

**Precautions for Correct Use**

Problem	Likely cause	Countermeasures
An error is displayed.	An alarm has occurred, the servo is OFF, or the deviation counter is reset.	<ul style="list-style-type: none"> <li>• Do not operate the Servomotor near the Limit Switches or Origin Proximity Sensor.</li> <li>• Turn the servo ON.</li> <li>• Release the deviation counter reset.</li> </ul>
Values for Pn10 or other parameters related to gain are the same as before execution.	The load inertia cannot be estimated.	<ul style="list-style-type: none"> <li>• Lower Pn10 to 10 and Pn11 to 50, and then execute again.</li> <li>• Make the adjustment manually. (Input the calculated load inertia.)</li> </ul>
The Servomotor does not rotate.	The ECRST (pin 30) of CN1 is input.	<ul style="list-style-type: none"> <li>• Turn OFF the ECRST (pin 30) of CN1.</li> </ul>

---

---

## 7-4 Disabling the Automatic Gain Adjustment Function

---

This section provides precautions for disabling realtime autotuning and the adaptive filter. These functions are enabled by default.

---

**Precautions  
for Correct Use**

- When disabling the automatic adjustment function, the RUN Command Input (RUN) must be turned OFF.
- 

### Disabling Realtime Autotuning

By setting the Realtime Autotuning Mode Selection (Pn21) to 0, the automatic estimation of the Inertia Ratio (Pn20) will stop, and realtime autotuning will be disabled. However, the estimated Inertia Ratio (Pn20) will remain. If the Pn20 value is obviously incorrect, perform normal mode autotuning or calculate and set the appropriate value manually.

---

**Precautions  
for Correct Use**

- To enable the Realtime Autotuning Mode Selection (Pn21), turn OFF the RUN Command Input (RUN), and then turn it back ON.
-



## Disabling the Adaptive Filter

The adaptive filter function, which performs automatic tracking in response to the load resonance, can be disabled by setting the Adaptive Filter Selection (Pn23) to 0. If the adaptive filter is disabled when it is correctly operating, suppressed resonance will become apparent, and noise or vibration may occur. Therefore, before disabling the adaptive filter, perform copying function to the Notch Filter 1 Frequency (Pn1D) of the Adaptive Filter Table Number Display (Pn2F) from the Fit Gain Window on the front panel (refer to *Front Panel Display Example* on page 7-9) or manually set the Notch Filter 1 Frequency (Pn1D) based on the Adaptive Filter Table Number Display (Pn2F) in the following tables.

Pn2F	Notch Filter 1 Frequency (Hz)	Pn2F	Notch Filter 1 Frequency (Hz)	Pn2F	Notch Filter 1 Frequency (Hz)
0	(Disabled)	22	766	44	326
1	(Disabled)	23	737	45	314
2	(Disabled)	24	709	46	302
3	(Disabled)	25	682	47	290
4	(Disabled)	26	656	48	279
5	1482	27	631	49	269 (Disabled when Pn22 ≥ F)
6	1426	28	607	50	258 (Disabled when Pn22 ≥ F)
7	1372	29	584	51	248 (Disabled when Pn22 ≥ F)
8	1319	30	562	52	239 (Disabled when Pn22 ≥ F)
9	1269	31	540	53	230 (Disabled when Pn22 ≥ F)
10	1221	32	520	54	221 (Disabled when Pn22 ≥ E)
11	1174	33	500	55	213 (Disabled when Pn22 ≥ E)
12	1130	34	481	56	205 (Disabled when Pn22 ≥ E)
13	1087	35	462	57	197 (Disabled when Pn22 ≥ E)
14	1045	36	445	58	189 (Disabled when Pn22 ≥ E)
15	1005	37	428	59	182 (Disabled when Pn22 ≥ D)
16	967	38	412	60	(Disabled)
17	930	39	396	61	(Disabled)
18	895	40	381	62	(Disabled)
19	861	41	366	63	(Disabled)
20	828	42	352	64	(Disabled)
21	796	43	339		

- Set the Notch Filter 1 Frequency (Pn1D) to 1,500 when disabling the adaptive filter using the above table.

# 7-5 Manual Tuning

## Basic Settings

As described before, the OMNUC G-Series Servo Drives have an autotuning function. Depending on load conditions or other restrictions, however, readjustment may be required if the gain cannot be properly adjusted when autotuning is performed or the optimum responsiveness or stability is required to match each load. This section describes how to perform manual tuning for each control mode and function.

### ■ Before Manual Setting

The front panel or the Parameter Unit can be used to adjust the Servomotor (machine) while monitoring the operation or noise, but more reliable adjustment can be performed quickly by using waveform monitoring with the data tracing function of CX-Drive or by measuring the analog voltage waveform with the monitor function.

### Analog Monitor Output

The actual Servomotor speed, command speed, torque, and number of accumulated pulses can be measured in the analog voltage level using an oscilloscope or other device. Set the type of signal to be output and the output voltage level by setting the SP Selection (Pn07) and IM Selection (Pn08). For details, refer to *Control I/O Connector Specifications (CN1)* on page 3-9 and *Parameter Tables* on page 5-33.

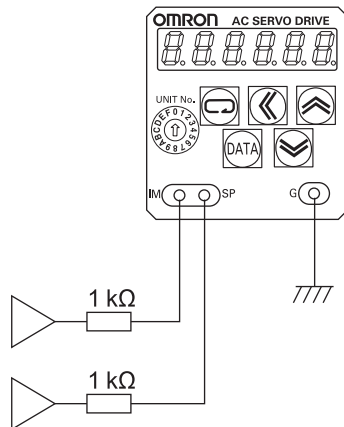

### CX-Drive Data Tracing

Commands to the Servomotor and Servomotor operation (e.g., speed, torque commands, and position deviation) can be displayed on a computer as waveforms. Refer to the *CX-Drive Operation Manual* (Cat. No. W453).

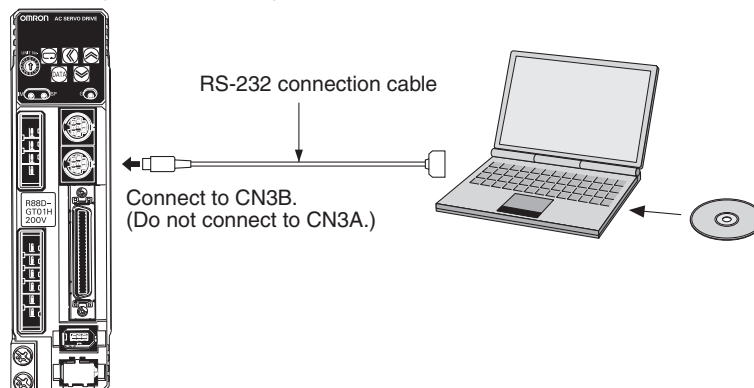

### ■ Position Control Mode Adjustment

Use the following procedure to make adjustments in position control for the OMNUC G Series.

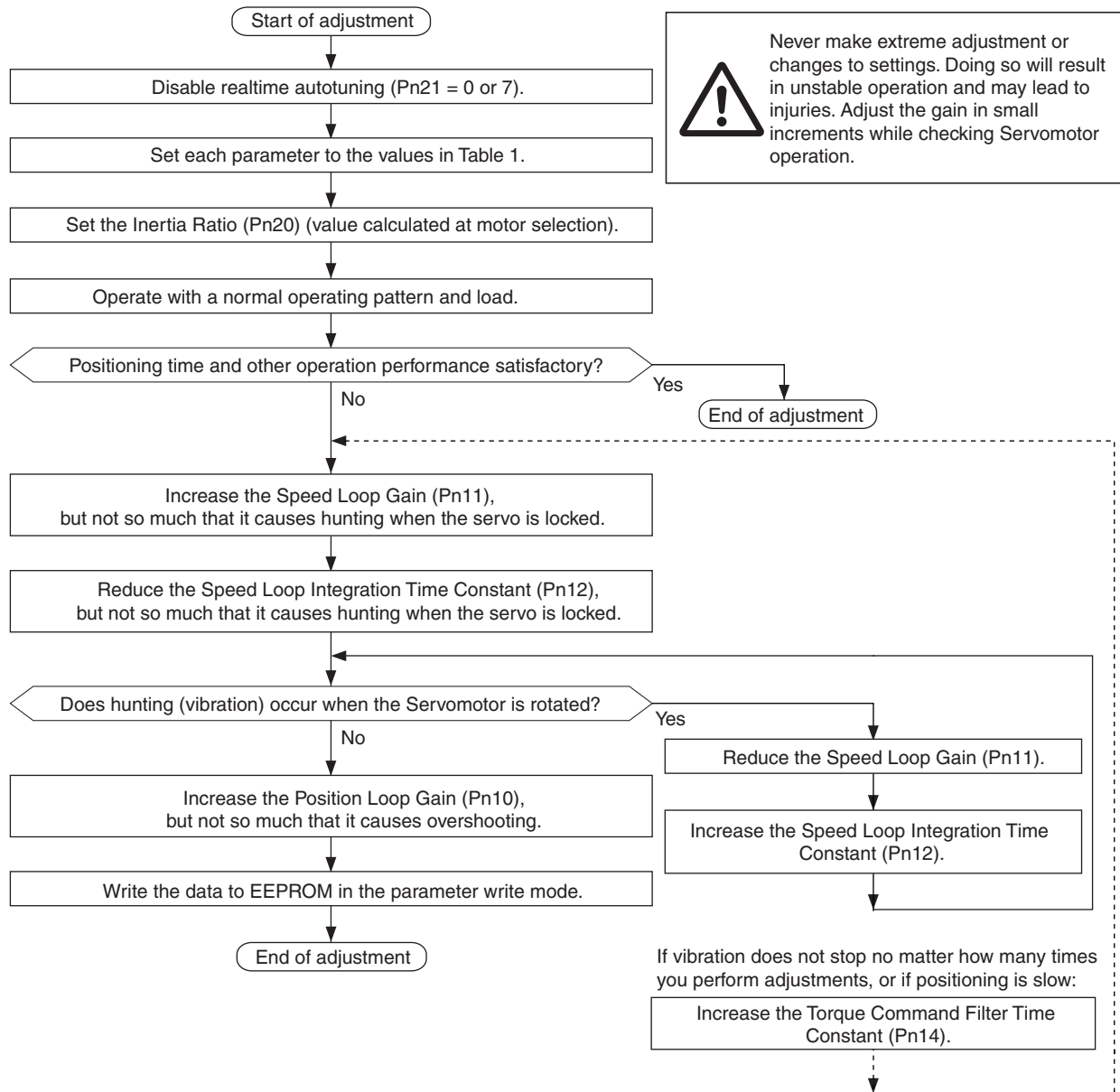

Never make extreme adjustment or changes to settings. Doing so will result in unstable operation and may lead to injuries. Adjust the gain in small increments while checking Servomotor operation.

Set the following parameters.

Table 1: Parameter Adjustment Values

Parameter No.	Parameter name	Guideline
Pn10	Position Loop Gain	30
Pn11	Speed Loop Gain	50
Pn12	Speed Loop Integration Time Constant	40
Pn13	Speed Feedback Filter Time Constant	0
Pn14	Torque Command Filter Time Constant	160
Pn15	Feed-forward Amount	0
Pn16	Feed-forward Command Filter	0
Pn18	Position Loop Gain 2	30
Pn19	Speed Loop Gain 2	50
Pn1A	Speed Loop Integration Time Constant 2	40
Pn1B	Speed Feedback Filter Time Constant 2	0
Pn1C	Torque Command Filter Time Constant 2	160
Pn1D	Notch Filter 1 Frequency	1500
Pn1E	Notch Filter 1 Width	2
Pn20	Inertia Ratio	*1

\*1. Input the Inertia Ratio (Pn20). The inertia ratio can be measured with normal mode autotuning or set to a calculated value. When the inertia ratio is unknown, enter 300 as the inertia ratio.

### ■ Speed Control Mode Adjustment

With the OMNUC G Series, adjustments for speed control are almost the same as adjustments for the position control mode. Use the following procedure to adjust parameters except for setting the Position Loop Gain and Speed Feed-forward.

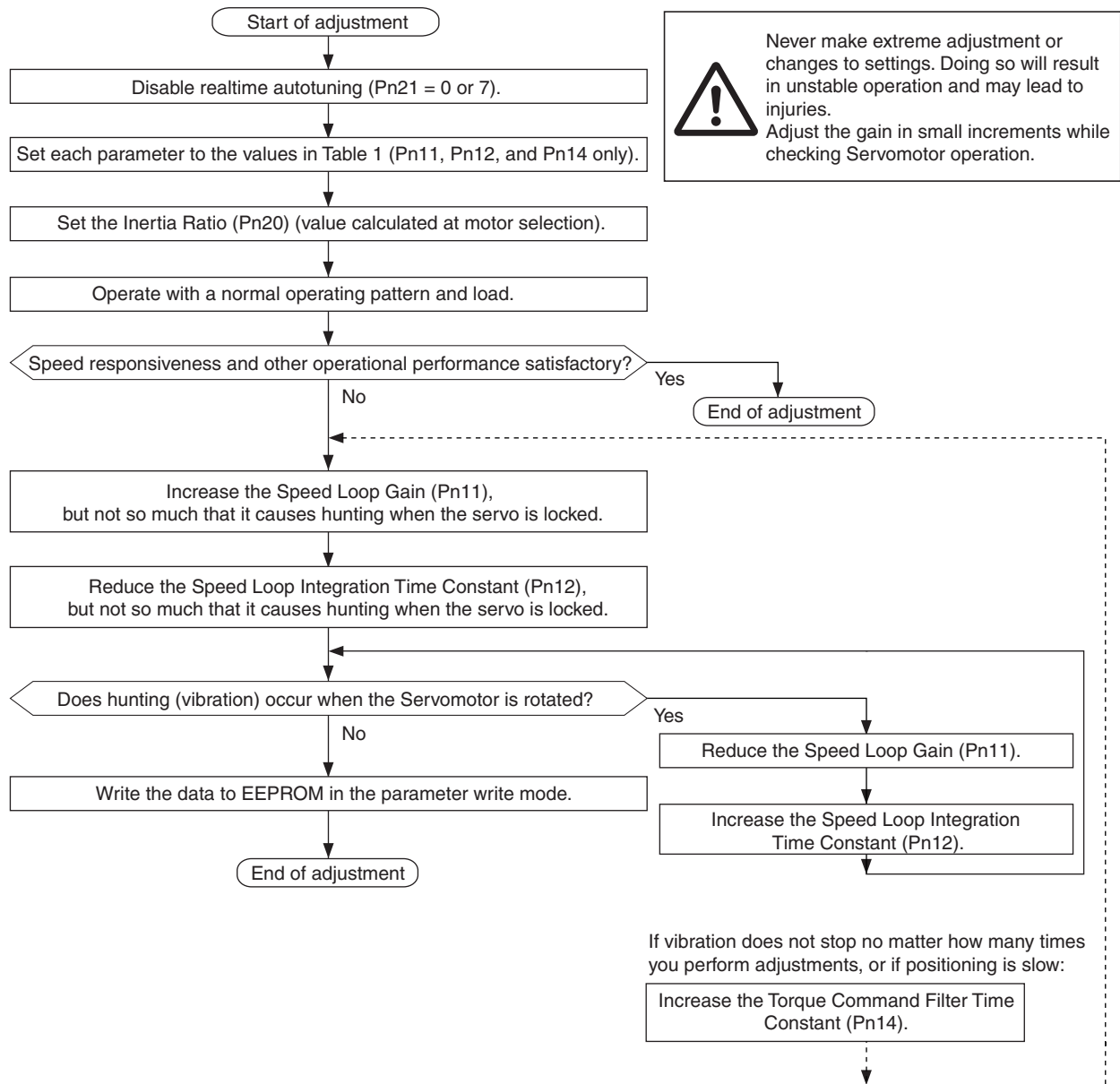

### ■ Torque Control Mode Adjustment

Torque control is based on a speed control loop using the No. 4 Internally Set Speed (Pn56) or the Speed Command Input/Torque Command Input as the speed limit. This section describes the settings for these speed limit values.

#### Setting Speed Limit Values

Set the speed limit value in the No.4 Internally Set Speed (Pn56) (if the Torque Command/Speed Limit Selection (Pn5B) is set to 0) or input the speed limit value to the Speed Command Input/Torque Command Input (REF/TREF1) (if the Torque Command/Speed Limit Selection (Pn5B) is set to 1).

- When the Servomotor nears the speed limit, it will switch from torque control following the analog torque command to speed control commanded with speed limit values determined by the No. 4 Internally Set Speed (Pn56) or the Speed Command Input/Torque Command Input (REF/TREF1).
- Parameters must be set according to the procedure given in *Speed Control Mode Adjustment* to perform stable operation when the speed is limited.
- The input to the torque limit section will be small and the torque may not be produced as specified by the analog torque command if the No.4 Internally Set Speed (Pn56) or the Speed Command Input/Torque Command Input (REF/TREF1) is too small or if the Speed Loop Gain is too low or the Speed Loop Integration Time Constant is 1000 (disabled).

## Gain Switching Function

With manual tuning, Gain 1 and Gain 2 can be set manually. The gain can be switched according to the operation.

Switching from Gain 1 to Gain 2 can be used for the following applications.

- To increase responsiveness by increasing the gain during operation.
- To increase servo lock rigidity by increasing the gain when operation is stopped.
- To switch to an optimal gain according to the operating mode.
- To reduce the gain to suppress vibration when operation is stopped.

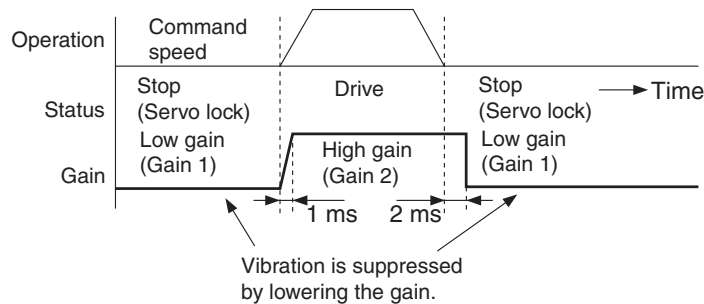

### Application Example

The example is for a case where noise is a problem when the Servomotor is stopped (servo lock), and the noise is reduced by switching to a lower gain setting after the Servomotor has stopped. Refer to *Normal Mode Autotuning* on page 7-16 for information on making adjustments.

Parameter No.	Parameter name	Perform manual tuning without gain switching.	Set Gain 2 (Pn18 to Pn1C) to the same values as Gain 1 (Pn10 to Pn14).	Set gain switching conditions (Pn30 to Pn35).	Adjust Pn11 and Pn14 (for Gain 1) when stopped.
Pn10	Position Loop Gain	60			
Pn11	Speed Loop Gain	50			30
Pn12	Speed Loop Integration Time Constant	16			
Pn13	Speed Feedback Filter Time Constant	0			
Pn14	Torque Command Filter Time Constant	50			85
Pn15	Feed-forward Amount	300			
Pn16	Feed-forward Command Filter	50			
Pn18	Position Loop Gain 2		60		
Pn19	Speed Loop Gain 2		50		
Pn1A	Speed Loop Integration Time Constant 2		16		
Pn1B	Speed Feedback Filter Time Constant 2		0		
Pn1C	Torque Command Filter Time Constant 2		60		

Parameter No.	Name	Perform manual tuning without gain switching.	Set Gain 2 (Pn18 to Pn1C) to the same values as Gain 1 (Pn10 to Pn14).	Set gain switching conditions (Pn30 to Pn35).	Adjust Pn11 and Pn14 (for Gain 1) when stopped.
Pn20	Inertia Ratio	<ul style="list-style-type: none"> <li>Enter the value for load calculation if already known.</li> <li>Perform normal mode auto-tuning and measure the inertia ratio.</li> <li>The default is 300.</li> </ul>			
Pn30	Gain Switching Input Operating Mode Selection	0		1	
Pn31	Control Gain Switch 1 Setting			7	
Pn32	Gain Switch 1 Time			30	
Pn33	Gain Switch 1 Level Setting			0	
Pn34	Gain Switch 1 Hysteresis Setting			0	
Pn35	Position Loop Gain Switching Time			0	

■ Setting Gain Switching Conditions

Position Control Mode (○: Relevant parameter enabled, ---: Disabled)

Gain Switch Setting			Setting parameters for position control mode		
Pn31	Conditions for switching to gain 2	Figure	Gain Switch Time *1	Gain Switch Level Setting	Gain Switch Hysteresis Setting *2
			Pn32	Pn33	Pn34
0	Always gain 1	---	---	---	---
1	Always gain 2	---	---	---	---
2	Switching using Gain Switch Input (GSEL)	---	---	---	---
3	Amount of change in torque command	---	○	○ *3 (0.05%/166 μs)	○ *3 (0.05%/166 μs)
4	Always gain 1	A	---	---	---
5	Command speed	---	○	○ (r/min)	○ (r/min)
6	Amount of position deviation	C	○	○ *4 (pulse)	○ *4 (pulse)
7	Command pulses received	D	○	---	---
8	Positioning Completed Output	F	○	---	---
9	Actual Servomotor speed	C	○	○ (r/min)	○ (r/min)
10	Combination of command pulse input and speed	G	○	○ (r/min) *6	○ (r/min) *6



## Speed Control Mode

Gain Switch Setting			Setting parameters for speed control mode		
Pn31	Conditions for switching to gain 2	Figure	Gain Switch Time <sup>*1</sup>	Gain Switch Level Setting	Gain Switch Hysteresis Setting <sup>*2</sup>
			Pn32, 37	Pn33, 38	Pn34, 39
0	Always gain 1	---	---	---	---
1	Always gain 2	---	---	---	---
2	Switching using Gain Switch Input (GSEL)	---	---	---	---
3	Amount of change in torque command	A	○	○ <sup>*3</sup> (0.05%/166 μs)	○ <sup>*3</sup> (0.05%/166 μs)
4	Amount of change in speed command	B	○	○ <sup>*5</sup> (10 r/min/s)	○ <sup>*5</sup> (10 r/min/s)
5	Command speed	C	○	○ (r/min)	○ (r/min)

## Torque Control Mode

Gain Switch Setting			Setting parameters for torque control mode		
Pn31	Conditions for switching to gain 2	Figure	Gain Switch Time <sup>*1</sup>	Gain Switch Level Setting	Gain Switch Hysteresis Setting <sup>*2</sup>
			Pn32, 37	Pn33, 38	Pn34, 39
0	Always gain 1	---	---	---	---
1	Always gain 2	---	---	---	---
2	Switching using Gain Switch Input (GSEL)	---	---	---	---
3	Amount of change in torque command	---	○	○ <sup>*3</sup> (0.05%/166 μs)	○ <sup>*3</sup> (0.05%/166 μs)

\*1. The Gain Switch Time (Pn32, Pn37) is used when returning from gain 2 to gain 1.

\*2. The Gain Switch Hysteresis Setting (Pn34, Pn39) is defined as shown in the following figure.

\*3. A setting of 200 is used for a 10% change in torque over a period of 166 μs.  
 $10\%/166 \mu\text{s} = \text{setting of } 200 \times (0.05\%/166 \mu\text{s})$ .

\*4. Specify the encoder resolution based on the control mode.

\*5. The setting is 1 given the condition of a change in speed of 10 r/min. over a period of 1 s.

\*6. The delay, level, and hysteresis have different meanings when Pn31 = 10. (Refer to figure F.)

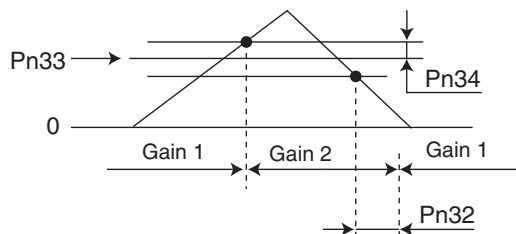

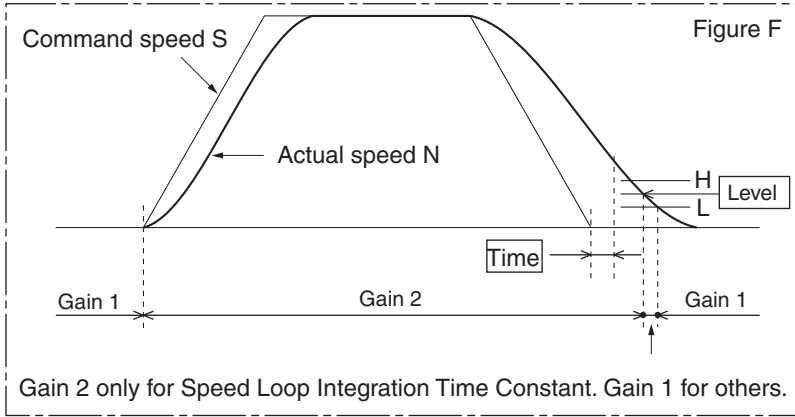
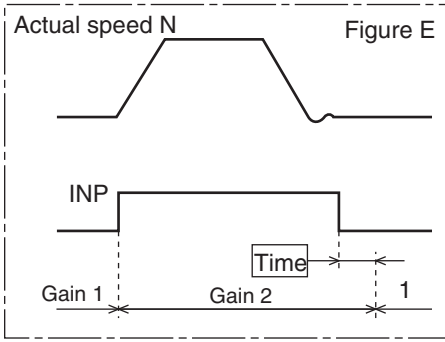
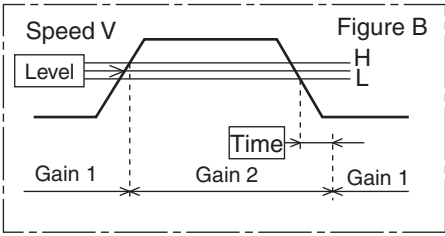
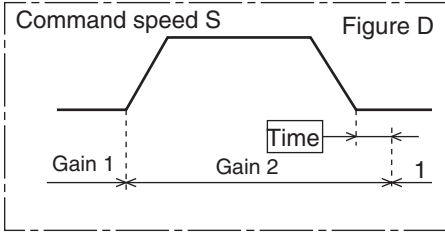
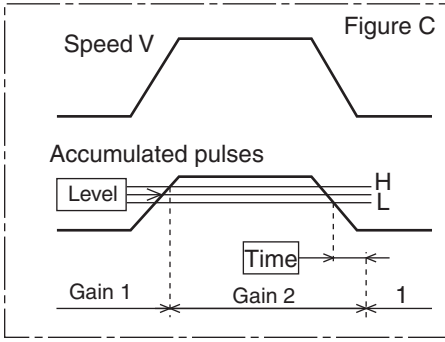
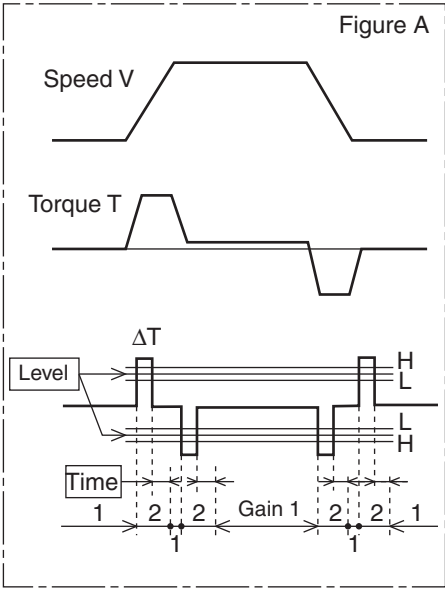

## Machine Resonance Control

When machine rigidity is low, shaft torsion may cause resonance, leading to vibration or noise, thus not allowing the gain to be set to a high value. In this case, the resonance can be suppressed by using the two filter types.

### Torque Command Filter (Pn14, Pn1C)

The filter time constant is set to attenuate the resonance frequency. The cut-off frequency can be calculated using the following equation.

$$\text{Cut-off frequency (Hz) } f_c = \frac{1}{2\pi T} = \frac{1}{2\pi \times \text{parameter setting} \times 10^{-5}}$$

### Notch Filter

- Adaptive Filter (Pn23, Pn2F)

The OMNUC G-Series Servo Drives use an adaptive filter to control vibration for loads that are difficult to handle with the previous notch filters and torque filters, such as when each device has a different resonance point. The adaptive filter is enabled by setting the Adaptive Filter Selection (Pn23) to 1.

Parameter No.	Parameter name	Explanation
Pn23	Adaptive Filter Selection	1: The adaptive filter is enabled.
Pn2F	Adaptive Filter Table Number Display	Displays the table number corresponding to the frequency for the adaptive filter. The setting of this parameter cannot be changed.

- Notch Filters 1 and 2 (Pn1D, Pn1E, Pn28, Pn29, and Pn2A)

The OMNUC G-Series Servo Drives provide two normal notch filters. Notch Filter 1 can be used to adjust the frequency and width, and Notch Filter 2 can be used to adjust frequency, width, and depth with parameters.

Parameter No.	Parameter name	Explanation
Pn1D	Notch Filter 1 Frequency	Set 10% lower.
Pn1E	Notch Filter 1 Width	Set according to the characteristics of the resonance points.
Pn28	Notch Filter 2 Frequency	Set 10% lower.
Pn29	Notch Filter 2 Width	Set according to the characteristics of the resonance points.
Pn2A	Notch Filter 2 Depth	

## Notch Filter Characteristics

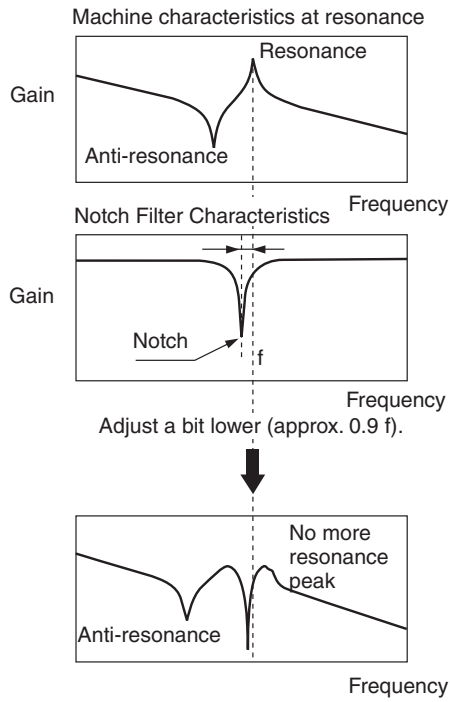

## Torque Command Filter

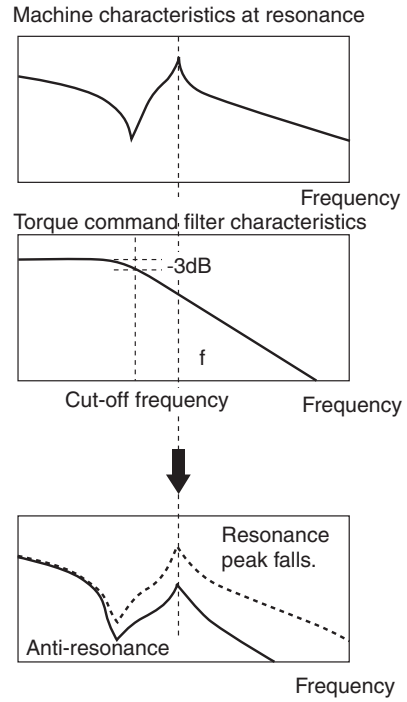

### Examples of applicable devices

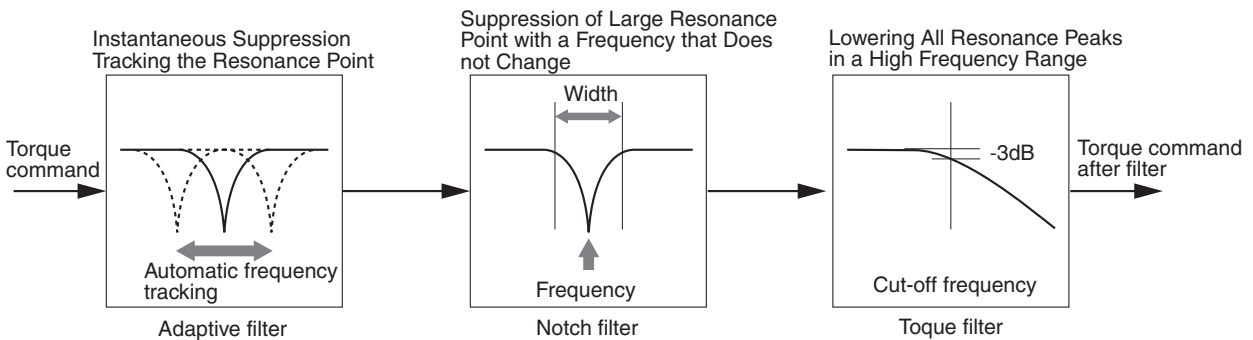
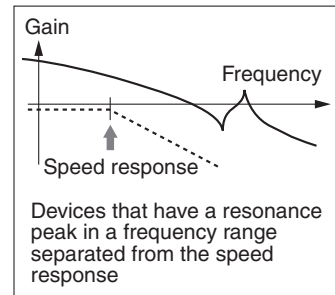
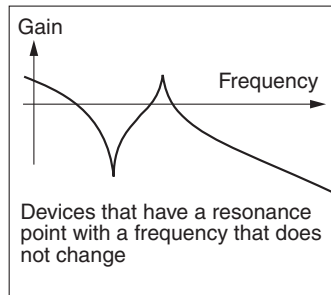
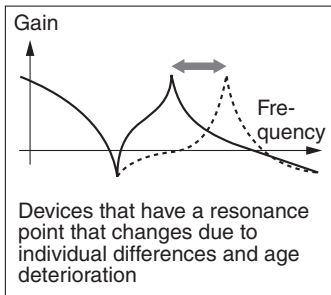

7

Adjustment Functions

## Automatic Gain Setting

Automatic gain setting initializes the control parameters and the gain switching parameters to gain settings for normal mode autotuning to match the rigidity before manual tuning is performed.

### Precautions for Correct Use

- Stop operation before making changes when executing the automatic gain setting function.

### ■ Operating Procedure

Refer to *Front Panel Display Example* on page 7-9.

1. **Stop operation.**
2. **Start the automatic gain setting function in the fit gain window on the front panel.**  
If the fit gain is completed normally, `[Finish]` will be displayed, and `[Error]` will be displayed if it is completed with an error. (The display can be cleared using the keys.)
3. **Write data to the EEPROM if the results are to be saved.**

### ■ Automatically Set Parameters

The following parameters are set automatically.

Parameter No.	Parameter name
Pn10	Position Loop Gain
Pn11	Speed Loop Gain
Pn12	Speed Loop Integration Time Constant
Pn13	Speed Feedback Filter Time Constant
Pn14	Torque Command Filter Time Constant
Pn18	Position Loop Gain 2
Pn19	Speed Loop Gain 2
Pn1A	Speed Loop Integration Time Constant 2
Pn1B	Speed Feedback Filter Time Constant 2
Pn1C	Torque Command Filter Time Constant 2

Settings for the following parameters are set automatically.

Parameter No.	Parameter name	Set value
Pn15	Feed-forward Amount	300
Pn16	Feed-forward Command Filter	50
Pn27	Instantaneous Speed Observer Setting	0
Pn30	Gain Switching Input Operating Mode Selection	1
Pn31	Control Gain Switch 1 Setting	10 <sup>*1</sup>
Pn32	Gain Switch 1 Time	30
Pn33	Gain Switch 1 Level Setting	50
Pn34	Gain Switch 1 Hysteresis Setting	33
Pn35	Position Loop Gain Switching Time	20
Pn36	Control Gain Switch 2 Setting	0

\*1. The setting is 10 for position control and 0 for speed and torque control.

## Instantaneous Speed Observer

The instantaneous speed observer improves speed detection accuracy, increases responsiveness, and reduces vibration at stopping by estimating the Servomotor speed using a load model.

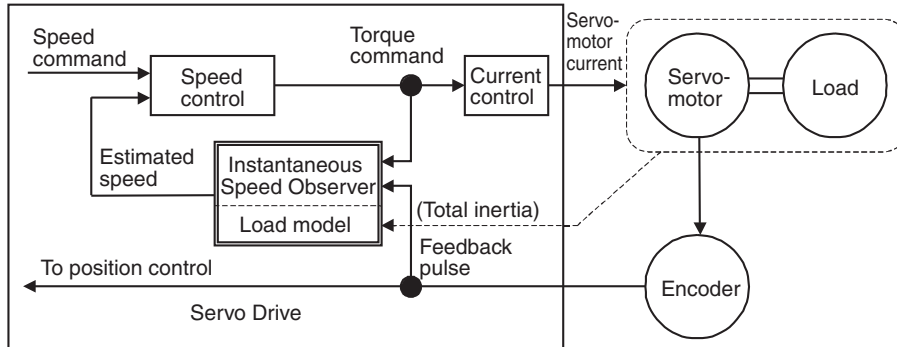

### Precautions for Correct Use

- The instantaneous speed observer cannot be used unless the following conditions are satisfied.

Conditions under which the instantaneous speed observer operates	
Control mode	<ul style="list-style-type: none"> <li>• Position control or speed control is used.                      Pn02 = 0: Position control                      Pn02 = 1: Speed control                      Pn02 = 3: Position/speed control                      Pn02 = 4: Position control only                      Pn02 = 5: Speed control only</li> </ul>
Encoder	<ul style="list-style-type: none"> <li>• A 7-core absolute encoder is used.</li> </ul>

- The instantaneous speed observer may not function properly or the effect may not be apparent under the following conditions.

Conditions under which the instantaneous speed observer does not function properly	
Load	<ul style="list-style-type: none"> <li>• If the margin of error with the actual device is too large for the inertia load of the Servomotor and load combined.                      Example : If there is a large resonance point at the frequency of 300 Hz or lower.                      : There is a non-linear element, such as large backlash.</li> <li>• If the load inertia changes.</li> <li>• If a large disturbance torque with high-frequency elements is applied.</li> </ul>
Others	<ul style="list-style-type: none"> <li>• If the stabilization range for positioning is extremely small.</li> </ul>

---

## ■ Operating Procedure

### 1. Set the Inertia Ratio (Pn20).

Set the inertia ratio as correctly as possible.

- Use the Pn20 setting if the Inertia Ratio (Pn20) is found using realtime autotuning that can be used in normal position control.
- Input the calculated value if it is already known by load calculation.
- If the inertia ratio is not known, perform normal mode autotuning and measure the inertia.

### 2. Perform adjustments for normal position control.

- Refer to *Position Control Mode Adjustment* on page 7-22.

### 3. Set the Instantaneous Speed Observer Setting (Pn27).

- Set the Instantaneous Speed Observer Setting (Pn27) to 1. The speed detection method will switch to Instantaneous Speed Observer.
- If the change in torque waveform or the operation noise is large, return the setting to 0 and check the precautions above as well as the Inertia Ratio (Pn20) again.
- If the change in torque waveform or the operation noise is small, make small adjustments in the Inertia Ratio (Pn20) to find the setting that makes the smallest change while monitoring the position deviation waveform and the actual speed waveform. If the Position Loop Gain or Speed Loop Gain is changed, the optimal setting for the Inertia Ratio (Pn20) may have changed, so set it again by making small adjustments.

## Damping Control

When the machine end vibrates, damping removes the vibration frequency from the commands, reducing vibration.

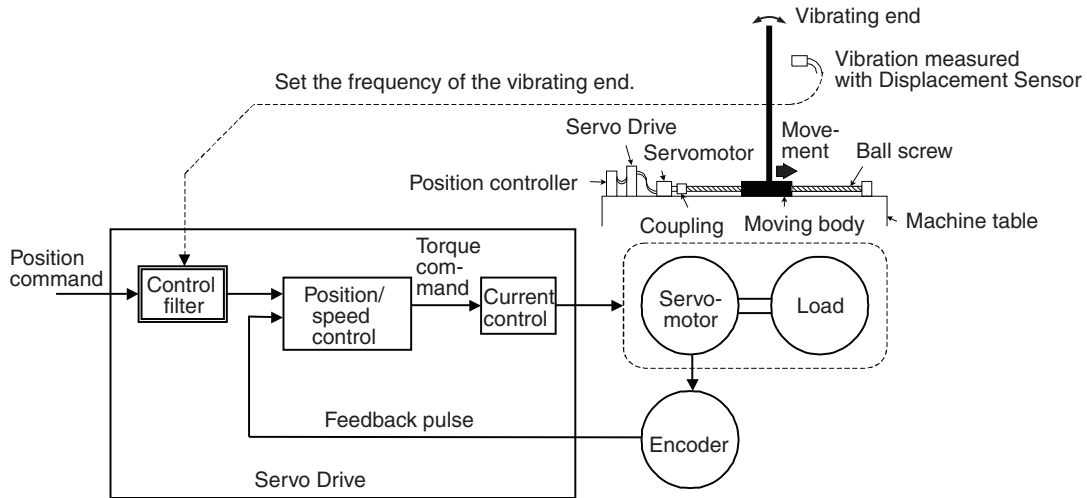

### Precautions for Correct Use

- The following conditions must be met to use damping control.

Conditions under which damping control operates	
Control Mode	<ul style="list-style-type: none"> <li>• The Position Control Mode must be used.</li> <li>Pn02 = 0: Position control</li> <li>Pn02 = 3: Control mode 1 for position/speed control</li> <li>Pn02 = 4: Control mode 1 for position/torque control</li> </ul>

- Stop operation before changing the parameters or switching with DFSEL/PNSEL.
- Under the following conditions, damping control may not operate properly or may have no effect.

Conditions under which the effect of damping control is inhibited	
Load	<ul style="list-style-type: none"> <li>• If forces other than commands, such as external forces, cause vibration.</li> <li>• If the ratio of the resonance frequency to anti-resonance frequency is large.</li> <li>• If the vibration frequency is outside the range of 10.0 to 200.0 Hz.</li> </ul>



■ Operating Procedure

**1. Setting the Vibration Frequency (Frequency 1: Pn2B, Frequency 2: Pn2D)**

Measure the vibration frequency at the end of the machine. When the end vibration can be measured directly using a laser displacement sensor, read the vibration frequency  $f$  (Hz) from the waveform measurement and set it as the Vibration Frequency (Pn2B, Pn2D). If no measurement device is available, use CX-Drive data tracing function, and read the residual vibration frequency (Hz) from the position deviation waveform as shown in the following figure.

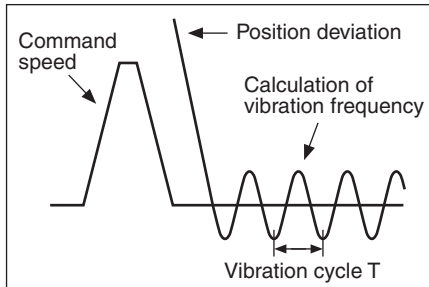

- The following gives the vibration frequency in the figure.

$$f \text{ (Hz)} = \frac{1}{T \text{ (s)}}$$

$$(\text{Pn2B, Pn2D}) = 10 \times f$$

- Example:  
When the vibration cycle is 100 ms and 20 ms, the vibration frequency is 10 Hz and 40 Hz, therefore set Pn2B = 100, Pn2D = 400.

**2. Setting the Vibration Filter (Filter 1: Pn2C, Filter 2: Pn2E)**

First, set the Vibration Filter (Pn2C, Pn2E) to 0. The stabilization time can be reduced by setting a large value; however, torque ripple will increase at the command change point as shown in the following figure. Set a range that will not cause torque saturation under actual operation conditions. The effects of vibration suppression will be lost if torque saturation occurs.

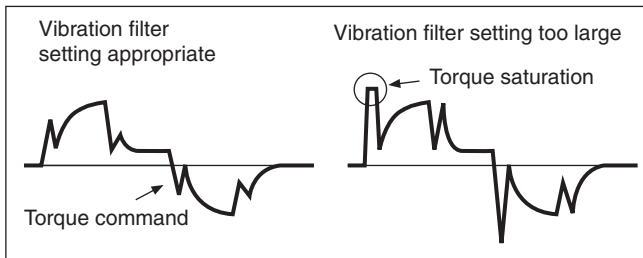

- The vibration filter setting is restricted by the following equation.  
 $10.0 \text{ Hz} - \text{Vibration frequency} \leq \text{Vibration filter setting} \leq \text{Vibration frequency}$

**3. Set the Vibration Filter Selection (Pn24).**

Vibration filters 1 and 2 can be switched according to the conditions of the machine vibration.

Pn24	Switching mode
0	No switching (1 and 2 both enabled)
1	Switching with DFSEL/PNSEL input Open: Vibration filter 1 Closed: Vibration filter 2
2	Switching with command direction Forward operation: Vibration filter 1 Reverse operation: Vibration filter 2



# Chapter 8

## Troubleshooting

8-1	Error Processing .....	8-1
	Preliminary Checks When a Problem Occurs .....	8-1
	Precautions When Troubleshooting .....	8-2
	Replacing the Servomotor and Servo Drive .....	8-2
8-2	Alarm Table .....	8-3
8-3	Troubleshooting .....	8-6
	Error Diagnosis Using the Displayed Alarm Codes .....	8-6
	Error Diagnosis Using the Operating Status .....	8-15
8-4	Overload Characteristics (Electronic Thermal Function) .....	8-20
	Overload Characteristics Graphs .....	8-20
8-5	Periodic Maintenance .....	8-21
	Servomotor Service Life .....	8-21
	Servo Drive Service Life .....	8-22
	Replacing the Absolute Encoder Battery .....	8-23

# 8-1 Error Processing

## Preliminary Checks When a Problem Occurs

This section explains the preliminary checks and analytical tools required to determine the cause of a problem if one occurs.

### ■ Checking the Power Supply Voltage

- Check the voltage at the power supply input terminals.

Main-circuit Power Supply Input Terminals (L1, L2, and L3)

R88D-GT□L (50 W to 400 W) : Single-phase 100 to 115 VAC (85 to 127 V), 50/60 Hz

R88D-GT□H (100 W to 1.5 kW) : Single-phase 200 to 240 VAC (170 to 264 V), 50/60 Hz

(750 W to 1.5 kW) : Three-phase 200 to 240 VAC (170 to 264 V), 50/60 Hz

(2 kW to 7.5 kW) : Three-phase 200 to 230 VAC (170 to 253 V), 50/60 Hz

Control Circuit Power Supply Input Terminals (L1C and L2C)

R88D-GT□L (50 W to 400 W) : Single-phase 100 to 115 VAC (85 to 127 V), 50/60 Hz

R88D-GT□H (100 W to 1.5 kW) : Single-phase 200 to 240 VAC (170 to 264 V), 50/60 Hz

(2 kW to 7.5 kW) : Single-phase 200 to 230 VAC (170 to 253 V), 50/60 Hz

If the voltage is outside of this range, there is a risk of operation failure, so be sure that the power supply is correct.

- Check the voltage of the sequence input power supply. (+24 VIN Terminal (CN1 pin 7))

Within the range of 11 to 25 VDC

If the voltage is outside of this range, there is a risk of operation failure, so be sure that the power supply is correct.

### ■ Checking Whether an Alarm Has Occurred

- Evaluate the problem using the 7-segment LED display on the front panel and using the operation keys. You can also evaluate the problem by using the R88A-PR02G Parameter Unit.
- When an alarm has occurred:
  - Check the alarm code that is displayed (□□) and evaluate the problem based on the alarm that is indicated.
- When an alarm has not occurred:
  - Make an analysis according to the problem.
- In either case, refer to *8-3 Troubleshooting* for details.

## Precautions When Troubleshooting

When checking and verifying I/O after a problem has occurred, the Servo Drive may suddenly start to operate or suddenly stop, so always take the following precautions.

You should assure that anything not described in this manual is not possible with this product.

### ■ Precautions

- Disconnect the cable before checking for wire breakage. Even if you test conduction with the cable connected, test results may not be accurate due to conduction via bypassing circuit.
- If the encoder signal is lost, the Servomotor may run away, or an error may occur. Be sure to disconnect the Servomotor from the mechanical system before checking the encoder signal.
- When measuring the encoder output, perform the measurement based on the SENGND (CN1 pin 13). When an oscilloscope is used for measurement, it will not be affected by noise if measurements are performed using the differential between CH1 and CH2.
- When performing tests, first check that there are no persons in the vicinity of the equipment, and that the equipment will not be damaged even if the Servomotor runs away. Before performing the tests, verify that you can immediately stop the machine using an emergency stop even if the Servomotor runs away.

## Replacing the Servomotor and Servo Drive

Use the following procedure to replace the Servomotor or Servo Drive.

### ■ Replacing the Servomotor

#### 1. Replace the Servomotor.

#### 2. Perform origin position alignment (for position control).

- When the Servomotor is replaced, the Servomotor's origin position (phase Z) may deviate, so origin alignment must be performed.
- Refer to the Position Controller's manual for details on performing origin alignment.

#### 3. Set up the absolute encoder.

- If a Servomotor with an absolute encoder is used, the absolute value data in the absolute encoder will be cleared when the Servomotor is replaced, so setup is again required. The rotation data will be different from before the Servomotor was replaced, so reset the initial Motion Control Unit parameters.
- For details, refer to *Absolute Encoder Setup Procedure* on page 6-5.

### ■ Replacing the Servo Drive

#### 1. Copy the parameters.

Use the Parameter Unit or the operation keys on the Servo Drive to write down all the parameter settings.

#### 2. Replace the Servo Drive.

#### 3. Set the parameters.

Use the Parameter Unit or the operation keys on the Servo Drive to set all the parameters.

#### 4. Set up the absolute encoder.

- If a Servomotor with an absolute encoder is used, the absolute value data in the absolute encoder will be cleared when the Servo Drive is replaced, so setup is again required. The rotation data will be different from before the Servo Drive was replaced, so reset the initial Motion Control Unit parameters.
- For details, refer to *Absolute Encoder Setup Procedure* on page 6-5.

---

---

## 8-2 Alarm Table

---

If the Servo Drive detects an error, the Alarm Output (ALM) will turn ON, the power drive circuit in the Servo Drive will turn OFF, and the alarm code will be displayed.

**Precautions  
for Correct Use**

- Refer to *Error Diagnosis Using the Displayed Alarm Codes* on page 8-6 for appropriate alarm countermeasures.
- Reset the alarm using one of the following methods. Remove the cause of the alarm first.
  - Turn ON the Alarm Reset Input (RESET).
  - Turn OFF the power supply, then turn it ON again.
  - Reset the alarm on the Parameter Unit.

Note, however, that some alarms can only be cleared by recycling the power (turn ON → OFF → ON). Refer to the *Alarms* table on the next page.

- If you clear an alarm while the RUN Command Input (RUN) is turned ON, the Servo Drive will start operation as soon as the alarm is cleared, which is dangerous. Be sure to turn OFF the RUN Command Input (RUN) before clearing the alarm. If the RUN Command Input (RUN) is always ON, first check safety sufficiently before clearing the alarm.
-

## ■ Alarms

Alarm code	Error detection function	Detection details and cause of error	Alarm reset possible
11	Control power supply undervoltage	The DC voltage of the main circuit fell below the specified value.	Yes
12	Overvoltage	The DC voltage in the main circuit is abnormally high.	Yes
13	Main power supply undervoltage	The DC voltage of the main circuit is low.	Yes
14	Overcurrent	Overcurrent flowed to the IGBT. Servomotor power line ground fault or short circuit.	No
15	Servo Drive overheating	The temperature of the Servo Drive radiator exceeded the specified value.	No
16	Overload	Operation was performed with torque significantly exceeding the rating for several seconds to several tens of seconds.	Yes
18	Regeneration overload	The regeneration energy exceeds the processing capacity of the regeneration resistor.	No
21	Encoder communications error	The encoder wiring is disconnected.	No
23	Encoder communications data error	Communications cannot be performed between the Encoder and the Servo Drive.	No
24	Deviation counter overflow	The number of accumulated pulses in the deviation counter exceeded the setting for the Deviation Counter Overflow Level (Pn70).	Yes
26	Overspeed	The Servomotor exceeded the maximum number of rotations.	Yes
27	Electronic gear setting error	The setting for the electronic gear ratio (Pn48 to 4B) is not appropriate.	Yes
34	Overrun limit error	The Servomotor exceeded the allowable operating range set in the Overrun Limit Setting (Pn26) with respect to the position command input.	Yes
36	Parameter error	Data in the parameter save area was corrupted when the power supply was turned ON and data was read from the EEPROM.	No
37	Parameter corruption	The checksum for the data read from the EEPROM when the power supply was turned ON does not match.	No
38	Drive prohibit input error	The forward drive prohibit and reverse drive prohibit inputs are both turned OFF.	Yes
39	Excessive analog input 1	A voltage exceeding the Speed Command/ Torque Command Input Overflow Level Setting (Pn71) was applied to the Speed Command Input (REF: CN1 pin 14).	Yes
40	Absolute encoder system down error	<b>ABS</b> The voltage supplied to the absolute encoder is lower than the specified value.	Yes
41	Absolute encoder counter overflow error	<b>ABS</b> The multi-turn counter of the absolute encoder exceeds the specified value.	No

## 8-2 Alarm Table

Alarm code	Error detection function	Detection details and cause of error	Alarm reset possible
42	Absolute encoder overspeed error <b>ABS</b>	The Servomotor rotation speed exceeds the specified value when only the battery power supply of the absolute encoder is used.	Yes
44	Absolute encoder one-turn counter error	A one-turn counter error was detected.	No
45	Absolute encoder multi-turn counter error	An absolute encoder multi-turn counter or incremental encoder phase-AB signal error was detected.	No
46	Encoder error 1	The Servomotor is faulty.	No
47	Absolute encoder status error <b>ABS</b>	The rotation of the absolute encoder is higher than the specified value.	Yes
48	Encoder phase Z error	A phase-Z pulse was not detected regularly.	No
49	Encoder PS signal error	A logic error was detected in the PS signal.	No
58	CPU error 1	The Servo Drive is faulty.	No
60	CPU error 2	The Servo Drive is faulty.	No
61	CPU error 3	The Servo Drive is faulty.	No
62	CPU error 4	The Servo Drive is faulty.	No
63	CPU error 5	The Servo Drive is faulty.	No
65	Excessive analog input 2	A voltage exceeding the Speed Command/ Torque Command Input Overflow Level Setting (Pn71) was applied to the analog command input (CN1 pin 16).	Yes
66	Excessive analog input 3	A voltage exceeding the Speed Command/ Torque Command Input Overflow Level Setting (Pn71) was applied to the analog command input (CN1 pin 18).	Yes
73	CPU error 6	The Servo Drive is faulty.	No
77	CPU error 7	The Servo Drive is faulty.	No
81	CPU error 8	The Servo Drive is faulty.	No
94	Encoder error 2	The Servomotor is faulty.	No
95	Servomotor non-conformity	The combination of the Servomotor and Servo Drive is not appropriate. The encoder was not connected when the power supply was turned ON.	No
96	CPU error 9	The Servo Drive is faulty.	No
97	CPU error 10	The Servo Drive is faulty.	No
99	CPU error 11	The Servo Drive is faulty.	No



## 8-3 Troubleshooting

If an error occurs in the machine, determine the error conditions from the alarm indicator and operating status, identify the cause of the error, and take appropriate countermeasures.

### Error Diagnosis Using the Displayed Alarm Codes

Alarm code	Error	Status when error occurs	Cause	Countermeasure
11	Power supply undervoltage	Occurs when the power supply is turned ON.	<ul style="list-style-type: none"> <li>• The power supply voltage is low.</li> <li>• Momentary power interruption occurred.</li> <li>• Power supply capacity is insufficient.</li> <li>• The power supply voltage is reduced because the main power supply is OFF.</li> <li>• The main power supply is not input.</li> </ul>	<ul style="list-style-type: none"> <li>• Increase the power supply capacity.</li> <li>• Change the power supply.</li> <li>• Turn ON the power supply.</li> </ul>
			<ul style="list-style-type: none"> <li>• Power supply capacity is insufficient.</li> </ul>	<ul style="list-style-type: none"> <li>• Increase the power supply capacity.</li> </ul>
			<ul style="list-style-type: none"> <li>• Phase loss.</li> </ul>	<ul style="list-style-type: none"> <li>• Connect the phases (L1, L2, L3) of the power supply voltage correctly.</li> <li>• For single-phase, connect to L1 and L3 correctly.</li> </ul>
			<ul style="list-style-type: none"> <li>• The main circuit power supply is damaged.</li> <li>• Control PCB error.</li> </ul>	<ul style="list-style-type: none"> <li>• Replace the Servo Drive.</li> </ul>

## 8-3 Troubleshooting

Alarm code	Error	Status when error occurs	Cause	Countermeasure
12	Overvoltage	Occurs when power supply is turned ON.	<ul style="list-style-type: none"> <li>Main circuit power supply voltage is outside allowable range.</li> </ul>	<ul style="list-style-type: none"> <li>Change the main circuit power supply voltage to within allowable range.</li> </ul>
		Occurs when Servomotor is decelerating.	<ul style="list-style-type: none"> <li>Load inertia is too great.</li> </ul>	<ul style="list-style-type: none"> <li>Calculate the regenerative energy, and connect an External Regeneration Resistor with the required regeneration absorption capacity.</li> <li>Extend the deceleration time.</li> </ul>
			<ul style="list-style-type: none"> <li>Main circuit power supply voltage is outside allowable range.</li> </ul>	<ul style="list-style-type: none"> <li>Change main circuit power supply voltage to within allowable range.</li> </ul>
		Occurs during descent (vertical axis).	<ul style="list-style-type: none"> <li>Gravitational torque is too large.</li> </ul>	<ul style="list-style-type: none"> <li>Add a counterbalance to the machine to lower gravitational torque.</li> <li>Slow the descent speed.</li> <li>Calculate the regenerative energy, and connect an External Regeneration Resistor with the required regeneration absorption capacity.</li> </ul>
13	Main power supply undervoltage	Occurs when the Servo Drive is turned ON.	<ul style="list-style-type: none"> <li>The power supply voltage is low.</li> <li>Momentary power interruption occurred.</li> <li>Power supply capacity is insufficient.</li> <li>The power supply voltage is reduced because the main power supply is OFF.</li> <li>The main power supply is not input.</li> </ul>	<ul style="list-style-type: none"> <li>Check the power supply capacity.</li> <li>Change the power supply.</li> <li>Turn ON the power supply.</li> <li>Extend the Momentary Hold Time (Pn6D).</li> </ul>
			<ul style="list-style-type: none"> <li>Phase loss.</li> </ul>	<ul style="list-style-type: none"> <li>Correctly connect the phases of the power supply voltage.</li> <li>Correctly connect the single phase.</li> </ul>
			<ul style="list-style-type: none"> <li>The main circuit power supply is damaged.</li> <li>Control PCB error.</li> </ul>	<ul style="list-style-type: none"> <li>Replace the Servo Drive.</li> </ul>

Alarm code	Error	Status when error occurs	Cause	Countermeasure
14	Overcurrent	Occurs when the Servo Drive is turned ON.	<ul style="list-style-type: none"> <li>Control PCB error</li> </ul>	<ul style="list-style-type: none"> <li>Replace the Servo Drive.</li> </ul>
			<ul style="list-style-type: none"> <li>Servomotor power line is short-circuited or ground-faulted between phases.</li> </ul>	<ul style="list-style-type: none"> <li>Repair the short-circuited or ground-faulted wire.</li> <li>Measure the insulation resistance at the Servomotor and, if there is a short-circuit, replace the Servomotor.</li> </ul>
			<ul style="list-style-type: none"> <li>Miswiring between phase U, phase V, phase W, and ground.</li> </ul>	<ul style="list-style-type: none"> <li>Correct the wiring.</li> </ul>
			<ul style="list-style-type: none"> <li>Servomotor winding is burned out.</li> </ul>	<ul style="list-style-type: none"> <li>Measure the winding resistance, and if the winding is burned out, replace the Servomotor.</li> </ul>
			<ul style="list-style-type: none"> <li>The relay for the dynamic brake has been consequently welded.</li> </ul>	<ul style="list-style-type: none"> <li>Do not frequently input the RUN Command Input.</li> <li>Do not operate the system by turning the servo ON and OFF.</li> </ul>
			<ul style="list-style-type: none"> <li>Servomotor non-conformity</li> </ul>	<ul style="list-style-type: none"> <li>Use a Servomotor that is appropriate for use with the Servo Drive.</li> </ul>
			<ul style="list-style-type: none"> <li>The pulse input timing is too fast.</li> </ul>	<ul style="list-style-type: none"> <li>Wait 100 ms min. before inputting pulses after turning ON the RUN Command Input (RUN).</li> </ul>
			<ul style="list-style-type: none"> <li>The resistor in the Servo Drive is abnormally overheating.</li> </ul>	<ul style="list-style-type: none"> <li>Reduce the ambient temperature of the Servo Drive to 55°C or lower.</li> <li>If the relay doesn't click when the power supply is turned ON, replace the Servo Drive.</li> </ul>
<ul style="list-style-type: none"> <li>The resistance of the connected External Regeneration Resistor is less than the minimum allowable value. (For the minimum allowable value, refer to page 4-48.)</li> </ul>	<ul style="list-style-type: none"> <li>Connect an External Regeneration Resistor whose resistance is more than the minimum allowable value. For the available combinations of External Regeneration Resistors and resistance values, refer to page 4-51.</li> </ul>			

## 8-3 Troubleshooting

Alarm code	Error	Status when error occurs	Cause	Countermeasure
15	Servo Drive overheating	Occurs during operation.	<ul style="list-style-type: none"> <li>• The ambient temperature is too high.</li> <li>• The load is too large.</li> </ul>	<ul style="list-style-type: none"> <li>• Lower the ambient temperature.</li> <li>• Increase the capacity of the Servo Drive and Servomotor.</li> <li>• Lighten the load.</li> <li>• Extend the acceleration and deceleration times.</li> </ul>
16	Overload	Occurs when the Servo Drive is turned ON.	<ul style="list-style-type: none"> <li>• There is an error in the Servomotor wiring (e.g., the wiring or the contacts are faulty).</li> </ul>	<ul style="list-style-type: none"> <li>• Wire the Servomotor power cable correctly.</li> </ul>
			<ul style="list-style-type: none"> <li>• The electromagnetic brake is ON.</li> </ul>	<ul style="list-style-type: none"> <li>• Turn OFF the brake.</li> </ul>
		Occurs during operation.	<ul style="list-style-type: none"> <li>• The Servo Drive is faulty.</li> </ul>	<ul style="list-style-type: none"> <li>• Replace the Servo Drive.</li> </ul>
			<ul style="list-style-type: none"> <li>• The actual torque exceeds the rated torque.</li> <li>• The starting torque exceeds the maximum torque.</li> </ul>	<ul style="list-style-type: none"> <li>• Review the load conditions and operating conditions.</li> <li>• Review the Servomotor capacity.</li> </ul>
			<ul style="list-style-type: none"> <li>• An unusual noise, oscillation, or vibration is caused by faulty gain adjustment.</li> </ul>	<ul style="list-style-type: none"> <li>• Adjust the gain correctly.</li> </ul>
			<ul style="list-style-type: none"> <li>• The Servo Drive is faulty.</li> </ul>	<ul style="list-style-type: none"> <li>• Replace the Servo Drive.</li> </ul>

Alarm code	Error	Status when error occurs	Cause	Countermeasure
18	Regeneration overload	Occurs when the Servomotor is decelerating.	<ul style="list-style-type: none"> <li>• Load inertia is too great.</li> </ul>	<ul style="list-style-type: none"> <li>• Calculate the regenerative energy, and connect an External Regeneration Resistor with the required regeneration absorption capacity.</li> <li>• Extend the deceleration time.</li> </ul>
			<ul style="list-style-type: none"> <li>• The deceleration time is too short.</li> <li>• The Servomotor rotation speed is too high.</li> </ul>	<ul style="list-style-type: none"> <li>• Reduce the Servomotor rotation speed.</li> <li>• Extend the deceleration time.</li> <li>• Calculate the regenerative energy, and connect an External Regeneration Resistor with the required regeneration absorption capacity.</li> </ul>
			<ul style="list-style-type: none"> <li>• The operating limit of the External Regeneration Resistor is limited to 10%.</li> </ul>	<ul style="list-style-type: none"> <li>• Set Pn6C to 2. For details, refer to <i>Parameters Details</i> on page 5-51.</li> </ul>
		Occurs during descent (vertical axis)	<ul style="list-style-type: none"> <li>• Gravitational torque is too large.</li> </ul>	<ul style="list-style-type: none"> <li>• Add a counterbalance to the machine to lower gravitational torque.</li> <li>• Reduce the descent speed.</li> <li>• Calculate the regenerative energy and connect an External Regeneration Resistor with the required regeneration absorption capacity.</li> </ul>
			<ul style="list-style-type: none"> <li>• The operating limit of the External Regeneration Resistor is limited to 10%.</li> </ul>	<ul style="list-style-type: none"> <li>• Set Pn6C to 2. For details, refer to <i>Parameters Details</i> on page 5-51.</li> </ul>
21	Encoder communications error	Occurs during operation.	<ul style="list-style-type: none"> <li>• The encoder is disconnected.</li> <li>• Connector contacts are faulty.</li> </ul>	<ul style="list-style-type: none"> <li>• Fix the locations that are disconnected.</li> <li>• Correct the wiring.</li> </ul>
			<ul style="list-style-type: none"> <li>• The encoder wiring is incorrect.</li> </ul>	<ul style="list-style-type: none"> <li>• Correct the wiring</li> </ul>
			<ul style="list-style-type: none"> <li>• The encoder is damaged.</li> </ul>	<ul style="list-style-type: none"> <li>• Replace the Servomotor.</li> </ul>
			<ul style="list-style-type: none"> <li>• The Servo Drive is faulty.</li> </ul>	<ul style="list-style-type: none"> <li>• Replace the Servo Drive.</li> </ul>
			<ul style="list-style-type: none"> <li>• The Servomotor is mechanically being held.</li> </ul>	<ul style="list-style-type: none"> <li>• If the Servomotor shaft is held by external force, release it.</li> </ul>

## 8-3 Troubleshooting

Alarm code	Error	Status when error occurs	Cause	Countermeasure
23	Encoder communications data error	Occurs when the power supply is turned ON or during operation.	• The encoder signal wiring is incorrect.	• Correct the wiring.
			• Noise on the encoder wiring causes incorrect operation.	• Take measures against noise on the encoder wiring.
			• The power supply voltage for the encoder has dropped (especially when the cable is long.)	• Provide the required encoder power supply voltage (5 VDC±5%).
24	Deviation counter overflow	Occurs when the Servomotor does not rotate even when command pulses are input.	• The Servomotor power wiring or the encoder wiring is incorrect.	• Correct the wiring.
			• The Servomotor is mechanically being held.	• If the Servomotor shaft is held by external force, release it. • Release the electro-magnetic brake.
			• Control PCB error.	• Replace the Servo Drive.
		Occurs during high-speed rotation.	• The Servomotor power wiring or the encoder wiring is incorrect.	• Correct the wiring.
		Occurs when a long string of command pulses is given.	• Gain adjustment is insufficient.	• Adjust the gain.
			• The acceleration and deceleration rapid.	• Extend the acceleration and deceleration times.
		Occurs during operation.	• The load is too large.	• Reduce the load. • Select a suitable Servomotor.
			• The setting for the Deviation Counter Overflow Level (Pn70) was exceeded.	• Increase the setting of Pn70. • Reduce the rotation speed. • Lighten the load. • Extend the acceleration and deceleration times.

Alarm code	Error	Status when error occurs	Cause	Countermeasure
26	Overspeed	Occurs during high-speed rotation.	• The speed command input is too large.	• Set the command pulse frequency to 500 kpps max.
			• The setting for the Electronic Gear Ratio Numerator (Pn48 or Pn49) is not appropriate.	• Set Pn48 and Pn49 so that the command pulse frequency is 500 kpps max.
			• The maximum number of rotations is exceeded due to overshooting.	• Adjust the gain. • Reduce the maximum command speed.
		• The encoder wiring is incorrect.	• Correct the wiring	
		Occurs when torque limit switching is used.	• The Overspeed Detection Level Setting (Pn73) has been exceeded.	• If torque limit switching is used, correctly set the allowable operating speed for Pn73.
27	Electronic gear setting error	Occurs when command signal is input or command is input.	• The result of multiplying the command pulse by the electronic gear ratio exceeded 80 Mpps. Refer to <i>5-8 Electronic Gear</i> on page 5-16.	• Check and review the command pulse frequency and the settings for the Electronic Gear Ratio parameters (Pn48 to Pn4B).
34	Overrun limit error	Occurs during operation.	• The Overrun Limit Setting (Pn26) is exceeded during operation.	• Adjust the gain. • Increase the setting for Pn26. • Set Pn26 to 0 to disable the function.
36	Overrun limit error	Occurs when the power supply is turned ON.	• There are data errors in the parameters that were read.	• Reset all parameters.
			• The Servo Drive is faulty.	• Replace the Servo Drive.
37	Parameter corruption	Occurs when the power supply is turned ON.	• The parameters that were read are corrupt.	• Replace the Servo Drive.
38	Drive prohibit input error	Occurs when the Servo Drive is turned ON or during operation.	• The Forward Drive Prohibit Input (POT) and Reverse Drive Prohibit Input (NOT) were both OFF at the same time.	• Correct the wiring. • Replace the limit sensor. • Check whether the power supply for control is input correctly. • Check whether the setting for Drive Prohibit Input Selection (Pn04) is correct.
39	Excessive analog input 1	Occurs during operation.	• The voltage input to pin 14 is too high.	• Lower the input voltage. • Change the value for Pn71.

## 8-3 Troubleshooting

Alarm code	Error	Status when error occurs	Cause	Countermeasure
40	Absolute encoder system down error <b>ABS</b>	Occurs when the power supply is turned ON or during operation.	<ul style="list-style-type: none"> <li>The voltage supplied to the absolute encoder is low.</li> </ul>	<ul style="list-style-type: none"> <li>Set up the absolute encoder.</li> <li>Connect the battery power supply.</li> </ul>
41	Absolute encoder counter overflow error <b>ABS</b>	Occurs during operation.	<ul style="list-style-type: none"> <li>The multi-turn counter of the absolute encoder exceeds the specified value.</li> </ul>	<ul style="list-style-type: none"> <li>Properly set the Operation Switch when Using Absolute Encoder (Pn0B).</li> </ul>
42	Absolute encoder overspeed error <b>ABS</b>	Occurs when the power supply is turned ON.	<ul style="list-style-type: none"> <li>The Servomotor rotation speed exceeds the specified value when the battery power supply is turned ON.</li> <li>The wiring is incorrect.</li> </ul>	<ul style="list-style-type: none"> <li>Lower the Servomotor rotation speed and supply power.</li> <li>Check the wiring.</li> </ul>
44	Absolute encoder one-turn counter error	Occurs when the power supply is turned ON.	<ul style="list-style-type: none"> <li>The encoder is faulty.</li> </ul>	<ul style="list-style-type: none"> <li>Replace the Servomotor.</li> </ul>
45	Absolute encoder multi-turn counter error	Occurs when the power supply is turned ON.	<ul style="list-style-type: none"> <li>The absolute encoder detected a counter error.</li> <li>The incremental encoder detected a counter error.</li> </ul>	<ul style="list-style-type: none"> <li>Replace the Servomotor.</li> </ul>
46	Encoder error 1	Occurs when the power supply is turned ON	<ul style="list-style-type: none"> <li>The Servomotor is faulty.</li> </ul>	<ul style="list-style-type: none"> <li>Replace the Servo Drive.</li> <li>Replace the Servomotor.</li> </ul>
47	Absolute encoder status error <b>ABS</b>	Occurs when the power supply is turned ON.	<ul style="list-style-type: none"> <li>The Servomotor was moving when the power supply was turned ON.</li> </ul>	<ul style="list-style-type: none"> <li>Do not let the Servomotor move when the power supply is turned ON.</li> </ul>
48	Encoder phase Z error	Occurs during operation.	<ul style="list-style-type: none"> <li>A phase-Z pulse from the encoder was not detected regularly.</li> </ul>	<ul style="list-style-type: none"> <li>Replace the Servomotor.</li> </ul>
49	Encoder PS signal error	Occurs during operation.	<ul style="list-style-type: none"> <li>A logic error was detected in the PS signal from the encoder.</li> </ul>	<ul style="list-style-type: none"> <li>Replace the Servomotor.</li> </ul>
58	CPU error 1	Occurs when the power supply is turned ON.	<ul style="list-style-type: none"> <li>The Servo Drive is faulty.</li> </ul>	<ul style="list-style-type: none"> <li>Replace the Servo Drive.</li> </ul>
60	CPU error 2	Occurs when the power supply is turned ON.	<ul style="list-style-type: none"> <li>The Servo Drive is faulty.</li> </ul>	<ul style="list-style-type: none"> <li>Replace the Servo Drive.</li> </ul>
61	CPU error 3	Occurs when the power supply is turned ON.	<ul style="list-style-type: none"> <li>The Servo Drive is faulty.</li> </ul>	<ul style="list-style-type: none"> <li>Replace the Servo Drive.</li> </ul>
62	CPU error 4	Occurs when the power supply is turned ON.	<ul style="list-style-type: none"> <li>The Servo Drive is faulty.</li> </ul>	<ul style="list-style-type: none"> <li>Replace the Servo Drive.</li> </ul>
63	CPU error 5	Occurs when the power supply is turned ON.	<ul style="list-style-type: none"> <li>The Servo Drive is faulty.</li> </ul>	<ul style="list-style-type: none"> <li>Replace the Servo Drive.</li> </ul>
65	Excessive analog input 2	Occurs during operation.	<ul style="list-style-type: none"> <li>The voltage input to pin 16 is too high.</li> </ul>	<ul style="list-style-type: none"> <li>Reduce the input voltage.</li> <li>Change the value for Pn71.</li> </ul>



Alarm code	Error	Status when error occurs	Cause	Countermeasure
66	Excessive analog input 3	Occurs during operation.	<ul style="list-style-type: none"> <li>The voltage input to pin 18 is too high.</li> </ul>	<ul style="list-style-type: none"> <li>Reduce the input voltage.</li> <li>Change the value for Pn71.</li> </ul>
73	CPU error 6	Occurs when the power supply is turned ON.	<ul style="list-style-type: none"> <li>The Servo Drive is faulty.</li> </ul>	<ul style="list-style-type: none"> <li>Replace the Servo Drive.</li> </ul>
77	CPU error 7	Occurs when the power supply is turned ON.	<ul style="list-style-type: none"> <li>The Servo Drive is faulty.</li> </ul>	<ul style="list-style-type: none"> <li>Replace the Servo Drive.</li> </ul>
81	CPU error 8	Occurs when the power supply is turned ON.	<ul style="list-style-type: none"> <li>The Servo Drive is faulty.</li> </ul>	<ul style="list-style-type: none"> <li>Replace the Servo Drive.</li> </ul>
94	Encoder error 2	Occurs when the power supply is turned ON.	<ul style="list-style-type: none"> <li>The Servomotor is faulty.</li> </ul>	<ul style="list-style-type: none"> <li>Replace the Servo Drive.</li> <li>Replace the Servomotor.</li> </ul>
95	Servomotor non-conformity	Occurs when the power supply is turned ON.	<ul style="list-style-type: none"> <li>The Servomotor and Servo Drive combination is incorrect.</li> </ul>	<ul style="list-style-type: none"> <li>Use a correct combination.</li> </ul>
			<ul style="list-style-type: none"> <li>The encoder wiring is disconnected.</li> </ul>	<ul style="list-style-type: none"> <li>Wire the encoder.</li> <li>Fix the locations that are disconnected.</li> </ul>
96	CPU error 9	Occurs when the power supply is turned ON.	<ul style="list-style-type: none"> <li>The Servo Drive is faulty.</li> </ul>	<ul style="list-style-type: none"> <li>Replace the Servo Drive.</li> </ul>
97	CPU error 10	Occurs when the power supply is turned ON.	<ul style="list-style-type: none"> <li>The Servo Drive is faulty.</li> </ul>	<ul style="list-style-type: none"> <li>Replace the Servo Drive.</li> </ul>
99	CPU error 11	Occurs when the power supply is turned ON.	<ul style="list-style-type: none"> <li>The Servo Drive is faulty.</li> </ul>	<ul style="list-style-type: none"> <li>Replace the Servo Drive.</li> </ul>

## Error Diagnosis Using the Operating Status

Symptom	Probable cause	Items to check	Countermeasures
The power LED indicator (PWR) does not light when the power supply is turned ON.	The power supply cable is wired incorrectly.	Check whether the power supply input is within the allowed voltage range.	Supply the correct voltage.
		Check whether the power supply input is wired correctly.	Correct the wiring.
The Servomotor does not rotate even if commands are input from the Controller. (Continued on next page.)	The RUN Command Input is OFF.	In monitor mode, check whether the RUN signal is ON or OFF.	<ul style="list-style-type: none"> <li>• Turn ON the RUN Command Input.</li> <li>• Correct the wiring.</li> </ul>
	The Forward Drive Prohibit Input (POT) and Reverse Drive Prohibit Input (NOT) are OFF.	In monitor mode, check whether the POT input and NOT input are ON or OFF.	<ul style="list-style-type: none"> <li>• Turn ON the POT and NOT inputs.</li> <li>• If the POT and NOT inputs are not used, disabled them.</li> </ul>
	The control mode is not correct.	Check the Control Mode Selection (Pn02).	Set the control mode to match the command type.
	The Deviation Counter Reset Input (ECRST) is ON.	In monitor mode, check whether the ECRST Input is ON or OFF.	<ul style="list-style-type: none"> <li>• Turn the ECRST Input OFF.</li> <li>• Correct the wiring.</li> </ul>
	The Command Pulse Mode (Pn42) is incorrect.	Check the Controller's command pulse type and the Servo Drive's command pulse type.	Set the Servo Drive's pulse type to match the Controller's command pulse type.
	The Zero Speed Designation Input (VZERO) is OFF.	In monitor mode, check whether the VZERO Input is ON or OFF.	<ul style="list-style-type: none"> <li>• Turn ON the VZERO Input.</li> <li>• Correct the wiring.</li> </ul>
	The internally set speeds are not set.	Check the settings for Pn53 to Pn56 or Pn74 to Pn77.	Set the desired speeds.
	No. 1 Torque Limit (Pn5E) or No. 2 Torque Limit (Pn5F) is set to 0.	Check the setting for Pn5E or Pn5F.	Return the setting to the default.
	The Servomotor Power Cable is wired incorrectly.	Check the wiring.	Correct the wiring.
	The Encoder Cable is wired incorrectly.		
	The Control I/O Connector (CN1) is wired incorrectly.	Check the command pulse's wiring.	Correct the wiring.
		Check the command pulse type.	Set the Servo Drive's pulse type to match the Controller's command pulse type.
		Check the command pulse's voltage.	Connect a resistor that matches the voltage.
	The power supply is not ON.	Check whether the power supply is ON and check the PWR LED indicator.	Turn ON the power supply.
Check the voltage across the power supply terminals.		Wire the power supply's ON circuit correctly.	
The speed command is disabled.	Check if the speed command procedure is correct.	<ul style="list-style-type: none"> <li>• Correctly set the external analog command.</li> <li>• Correctly set the internal speed.</li> </ul>	

Symptom	Probable cause	Items to check	Countermeasures
The Servomotor does not rotate even if commands are input from the Controller.	The torque command is disabled.	Check if the torque command input procedure is correct.	Correctly set the torque command.
	The CW Input and CCW Input are ON at the same time.	Check the command pulse's wiring.	<ul style="list-style-type: none"> <li>• Input the pulse signal either to the CW Input or CCW Input to the pulse signal.</li> <li>• Always turn OFF the terminal that is not being input to.</li> </ul>
	Servo Drive is faulty.	---	Replace the Servo Drive.
The Servomotor operates momentarily, but then it does not operate after that.	The Servomotor Power Cable is wired incorrectly.	Check the wiring of the Servomotor Power Cable's phases U, V, and W.	Wire correctly.
	The Encoder Cable is wired incorrectly.	Check the Encoder Cable's wiring.	Wire correctly.
The Servomotor rotates without a command.	The command pulse input is incorrect.	Check the command pulse type.	Set the correct command pulse input.
		Check the command pulse's voltage.	Connect a resistor that matches the voltage.
	Servo Drive is faulty.	---	Replace the Servo Drive.
The Servomotor rotates in the opposite direction from the command.	The CW input and CCW input connections are reversed.	Check the Controller's command pulse type and the Servo Drive's command pulse type.	Connect the CW pulse signal to the CW Input and the CCW pulse signal to the CCW Input.

## 8-3 Troubleshooting

Symptom	Probable cause	Items to check	Countermeasures
Servomotor rotation is unstable.	The Servomotor Power Cable or Encoder Cable is wired incorrectly.	Check the wiring of the Servomotor Power Cable's phases U, V, and W and check the Encoder Cable's wiring.	Wire correctly.
	The coupling system between the Servomotor shaft and the mechanical system has eccentricity or loose screws, or the torque is fluctuating due to engagement between pulleys or gears.	Check the mechanical system's coupling section.	Review and adjust the machine.
		Try rotating the Servomotor without a load. (Disconnect it from the mechanical system.)	
	The load's moment of inertia exceeds the Servo Drive's allowed value.	Try rotating the Servomotor without a load. (Disconnect it from the mechanical system.)	<ul style="list-style-type: none"> <li>• Lighten the load.</li> <li>• Replace the Servomotor and Servo Drive with higher capacity models.</li> </ul>
	The pulse signal line's connections are loose.	Check the pulse signal wiring at the Controller and Servo Drive.	Wire correctly.
		Check the Controller's command pulse type and the Servo Drive's command pulse type.	Set the Servo Drive's pulse type to match the Controller's command pulse type.
	The gain is wrong.	---	<ul style="list-style-type: none"> <li>• Use normal mode autotuning.</li> <li>• Adjust the gain manually.</li> </ul>
The CN1 input signal is chattering.	Check the RUN Command Input (RUN), Deviation Counter Reset Input (ECRST), Zero Speed Designation Input (VZERO), Internally set Speed Selection 1 Input (VSEL1) and Internally Set Speed Selection 2 Input (VSEL2).	Correct the wiring so that there is no chattering.	
The Servomotor is overheating.	The ambient temperature is too high.	Check that the ambient temperature around the Servomotor is below 40°C.	Lower the ambient temperature to 40°C or less. (Use a cooler or fan.)
	Ventilation is obstructed.	Check to see whether anything is blocking ventilation.	Improve ventilation.
	The Servomotor is overloaded.	Try rotating the Servomotor without a load. (Disconnect it from the mechanical system.)	<ul style="list-style-type: none"> <li>• Reduce the load.</li> <li>• Replace the Servomotor and Servo Drive with higher capacity models.</li> </ul>
	The Servomotor is vibrating.		
The holding brake is ineffective.	Power is supplied to the holding brake.	Check whether power is supplied to the holding brake.	Configure a circuit that cuts power to the holding brake when the motor stops and the load is held by the holding brake.
The Servomotor does not stop or is hard to stop even if the RUN Command Input (RUN) is turned OFF while the Servomotor is rotating.	The load inertia is too large.	Check the following: <ul style="list-style-type: none"> <li>• Is the load too large?</li> <li>• Is the Servomotor speed too high?</li> </ul>	Re-evaluate the load conditions and replace the Servomotor/Servo Drive with appropriate models if necessary.
	The stop circuit failed.	---	Replace the Servo Drive.

Symptom	Probable cause	Items to check	Countermeasures
The Servomotor is producing unusual noises or the machine is vibrating.	There are problems with the machine's installation.	Check whether the Servomotor's mounting screws are loose.	Tighten the mounting screws.
		Check whether the axes are misaligned in the mechanical coupling system.	Align the mechanical couplings.
		Check whether the coupling is unbalanced.	Adjust the coupling's balance.
	There is a problem with the bearings.	Check for noise or vibration around the bearings.	Contact your OMRON representative.
	The gain is wrong.	---	<ul style="list-style-type: none"> <li>• Use normal mode autotuning.</li> <li>• Adjust the gain manually.</li> </ul>
	The Speed Feedback Filter Time Constant (Pn13) is wrong.	Check the setting of Pn13.	Return the setting to 0 (default) or increase the setting.
	Noise is entering the Control I/O Cable because the cable does not meet specifications.	Check that the cable wire is a twisted-pair wire or shielded twisted-pair cable with wires of at least 0.08 mm <sup>2</sup> .	Use Control I/O Cable that meets specifications.
	Noise is entering the Control I/O Cable because the cable is longer than the specified length.	Check the length of the Control I/O Cable.	Shorten the Control I/O Cable to 3 m or less.
	Noise is entering the cable because the Encoder Cable does not meet specifications.	Check that the cable wires are shielded twisted-pair wires that are at least 0.12 mm <sup>2</sup> .	Use Encoder Cable that meets specifications.
	Noise is entering the Encoder Cable because the cable is longer than the specified length.	Check the length of the Encoder Cable.	Shorten the Encoder Cable to less than 50 m.
	Noise is entering the signal wires because the Encoder Cable is stuck or the sheath is damaged.	Check the Encoder Cable for cuts or other damage.	Correct the Encoder Cable's pathway to prevent damage.
	Too much noise is entering the Encoder Cable.	Separate the Encoder Cables far from high-current lines or check whether the lines are too close.	Install the Encoder Cable where it won't be subjected to surges.
	The FG's potential is fluctuating due to devices near the Servomotor, such as welding machines.	Check for ground problems (loss of ground or incomplete ground) at equipment such as welding machines near the Servomotor.	Ground the equipment properly and prevent currents from flowing to the encoder FG.
	Errors are being caused by excessive vibration or shock on the encoder.	There are problems with mechanical vibration or motor installation (such as the mounting surface, attachment, or axial offset).	Reduce the mechanical vibration or correct the Servomotor's installation.
	The machine and the Servomotor are resonating.	Check whether the machine is resonating.	<ul style="list-style-type: none"> <li>• Readjust the Torque Command Filter Time Constant.</li> <li>• If there is resonance, set the Notch Filter 1 Frequency (Pn1D) and Notch Filter 1 Width (Pn1E).</li> </ul>

## 8-3 Troubleshooting

Symptom	Probable cause	Items to check	Countermeasures
Vibration is occurring at the same frequency as the power supply.	Inductive noise is occurring.	Check whether the Servo Drive control signal lines are too long.	Shorten the control signal lines.
		Check to see whether control signal lines and power supply lines are bundled together.	<ul style="list-style-type: none"> <li>• Separate control signal lines from power supply lines.</li> <li>• Use a low-impedance power supply for control signals.</li> </ul>
The position is misaligned. (Position misalignment occurs without an alarm being output.)	There is an error in the coupling of the mechanical system and the Servomotor.	Check whether the coupling of the mechanical system and the Servomotor is misaligned.	Correct the coupling between the mechanical system and the Servomotor.
	Noise is entering the Deviation Counter Reset Input (ECRST).	Check whether the control signal lines and power supply lines are bundled together.	Separate the control signal lines from the power supply lines or take other measures against noise.
	The gain is wrong.	---	<ul style="list-style-type: none"> <li>• Perform normal mode autotuning.</li> <li>• Perform manual tuning.</li> </ul>
	The load inertia is too large.	Check the following: <ul style="list-style-type: none"> <li>• Check whether the load is too large.</li> <li>• Check whether the rotation speed of the Servomotor is too high.</li> </ul>	<ul style="list-style-type: none"> <li>• Adjust the gain.</li> <li>• Review the load conditions, and replace the Servomotor and Servo Drive with appropriate models.</li> </ul>

# 8-4 Overload Characteristics (Electronic Thermal Function)

An overload protection (electronic thermal) function is built into the Servo Drive to protect the Servo Drive and Servomotor from overloading.

If an overload does occur, first eliminate the cause of the error and then wait at least one minute for the Servomotor temperature to drop before turning ON the power again.

If the power is turned ON again repeatedly at short intervals, the Servomotor windings may burn out.

## Overload Characteristics Graphs

The following graphs show the characteristics of the load rate and electronic thermal function's operation time.

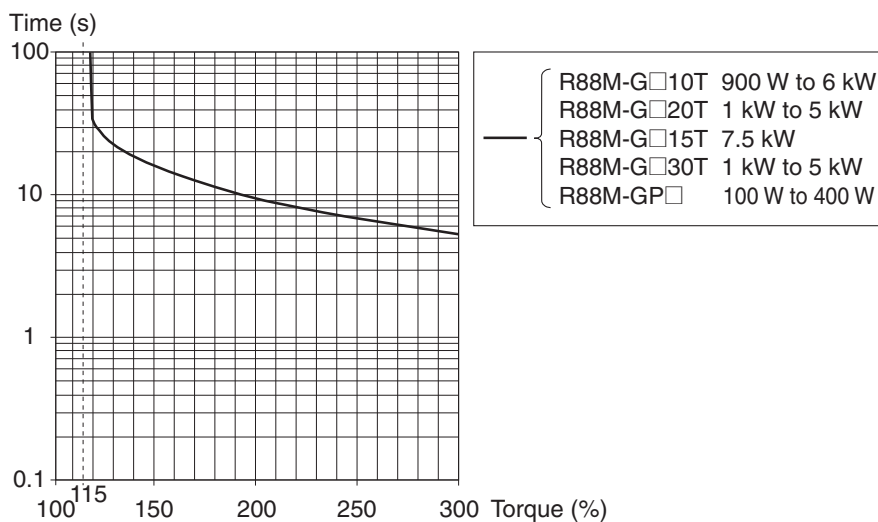
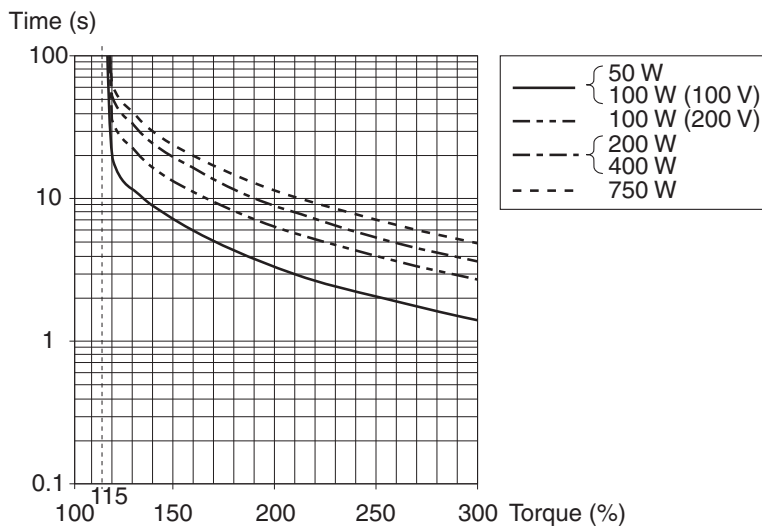

When the torque command = 0, and a constant torque command is continuously applied after three or more times the overload time constant has elapsed, the overload time  $t$  [s] will be:

$$t \text{ [s]} = - \text{Overload time constant [s]} \times \log_e (1 - \text{Overload level [\%]} / \text{Torque command [\%]})^2$$

(The overload time constant [s] depends on the Servomotor. The standard overload level is 115%.)

### Precautions for Correct Use

- Overload (alarm code 16) cannot be reset for approximately 10 seconds after its occurrence.

## 8-5 Periodic Maintenance



### Caution



Resume operation only after transferring to the new Unit the contents of the data required for operation. Not doing so may result in equipment damage.



Do not attempt to disassemble or repair any of the products. Any attempt to do so may result in electric shock or injury.

Servomotors and Servo Drives contain many components and will operate properly only when each of the individual components is operating properly.

Some of the electrical and mechanical components require maintenance depending on application conditions. Periodic inspection and part replacement are necessary to ensure proper long-term operation of Servomotors and Servo Drives. (quotes from "The Recommendation for Periodic Maintenance of a General-purpose Inverter" published by JEMA)

The periodic maintenance cycle depends on the installation environment and application conditions of the Servomotor or Servo Drive.

Recommended maintenance times are listed below for Servomotors and Servo Drives. Use these for reference in determining actual maintenance schedules.

### Servomotor Service Life

- The service life for components is listed below.

Bearings: 20,000 hours

Decelerator: 20,000 hours

Oil seal: 5,000 hours

Encoder: 30,000 hours

These values presume an ambient Servomotor operating temperature of 40°C, shaft loads within the allowable range, rated operation (rated torque and rated r/min), and proper installation as described in this manual.

You can request replacement of the bearings, Decelerator, Oil Seal, or encoder as repair work.

- The radial loads during operation (rotation) on timing pulleys and other components contacting belts is twice the still load. Consult with the belt and pulley manufacturers and adjust designs and system settings so that the allowable shaft load is not exceeded even during operation. If a Servomotor is used under a shaft load exceeding the allowable limit, the Servomotor shaft can break, the bearings can burn out, and other problems can occur.



---

## Servo Drive Service Life

- Details on the service life of the Servo Drive are provided below.
  - Aluminum electrolytic capacitors: 28,000 hours  
(at an ambient Servo Drive operating temperature of 55°C, the rated operation output (rated torque), installed as described in this manual.)
  - Axial fan: 10,000 to 30,000 hours
  - Inrush current prevention relay: Approx. 20,000 operations (The service life depends on the operating conditions.)
- When using the Servo Drive in continuous operation, use fans or air conditioners to maintain an ambient operating temperature below 40°C.
- We recommend that ambient operating temperature and the power ON time be reduced as much as possible to lengthen the service life of the Servo Drive.
- The life of aluminum electrolytic capacitors is greatly affected by the ambient operating temperature. Generally speaking, an increase of 10°C in the ambient operating temperature will reduce capacitor life by 50%.
- The aluminum electrolytic capacitors deteriorate even when the Servo Drive is stored with no power supplied. If the Servo Drive is not used for a long time, we recommend a periodic inspection and part replacement schedule of five years.
- If the Servomotor or Servo Drive is not to be used for a long time, or if they are to be used under conditions worse than those described above, a periodic inspection schedule of five years is recommended.
- Upon request, OMRON will examine the Servo Drive and Servomotor and determine if a replacement is required.

## Replacing the Absolute Encoder Battery **ABS**

Replace the Absolute Encoder Backup Battery if it has been used for more than three years or if an absolute encoder system down error (alarm code 40) has occurred.

### ■ Replacement Battery Model and Specifications

Item	Specifications
Name	Absolute Encoder Backup Battery
Model	R88A-BAT01G
Battery model	ER6V (Toshiba)
Battery voltage	3.6 V
Current capacity	2000 mA·h

### ■ Mounting the Backup Battery

#### Mounting the Battery for the First Time

Connect the absolute encoder battery to the Servomotor, and then set up the absolute encoder.

Refer to *Absolute Encoder Setup Procedure* on page 6-5.

Once the absolute encoder battery is attached, it is recommended that the control power supply be turned ON and OFF once a day to refresh the battery.

If you neglect to refresh the battery, battery errors will occur due to voltage delay in the battery.

#### Replacing the Battery

If a battery alarm occurs, the absolute encoder battery must be replaced.

Replace the battery with the control power supply of the Servo Drive ON. If the battery is replaced with the control power supply of the Servo Drive OFF, data held in the encoder will be lost.

Clear the battery alarm by any of the following methods after you replace the absolute encoder battery.

- ♦ Use the alarm reset of the CN1 control input.
- ♦ Clear the alarm by the alarm reset from the Parameter Unit. For details, refer to *Alarm Reset* on page 6-21.
- ♦ Select the Absolute Encoder tab page on CX-Drive and clear the battery alarm.

**Note** If the absolute encoder is cleared, or the absolute encoder is cleared using communications, all error and rotation data will be lost and the absolute encoder must be set up again. For details, refer to *Absolute Encoder Setup* on page 6-5.

**Battery Mounting Procedure**

1. Prepare the R88A-BAT01G replacement battery.

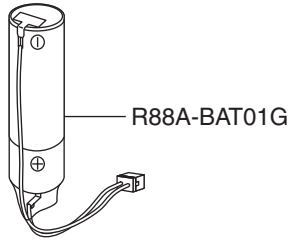

2. Remove the battery box cover.

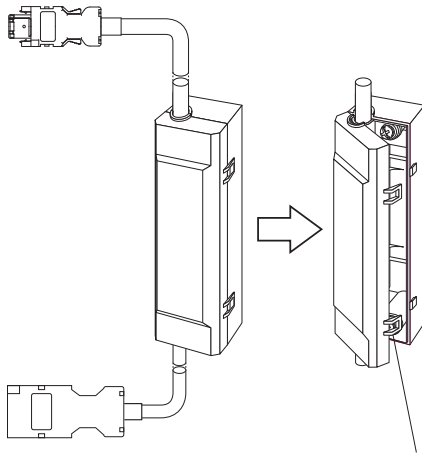

Raise the hooks to remove the cover.

3. Put the battery into the battery box.

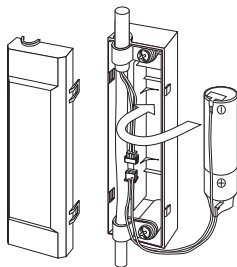

Insert the battery.

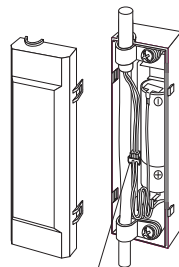

Attach the connector.

4. Close the cover to the battery box.

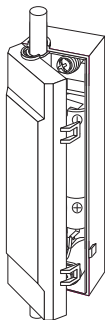

Make sure that the connector wiring does not get caught when closing the cover to the battery box.





# Chapter 9

## Appendix

9-1	Connection Examples .....	9-1
9-2	Parameter Tables.....	9-11

# 9-1 Connection Examples

## ■ Connection Example 1: Connecting to SYSMAC CJ1W-NC133/233/433

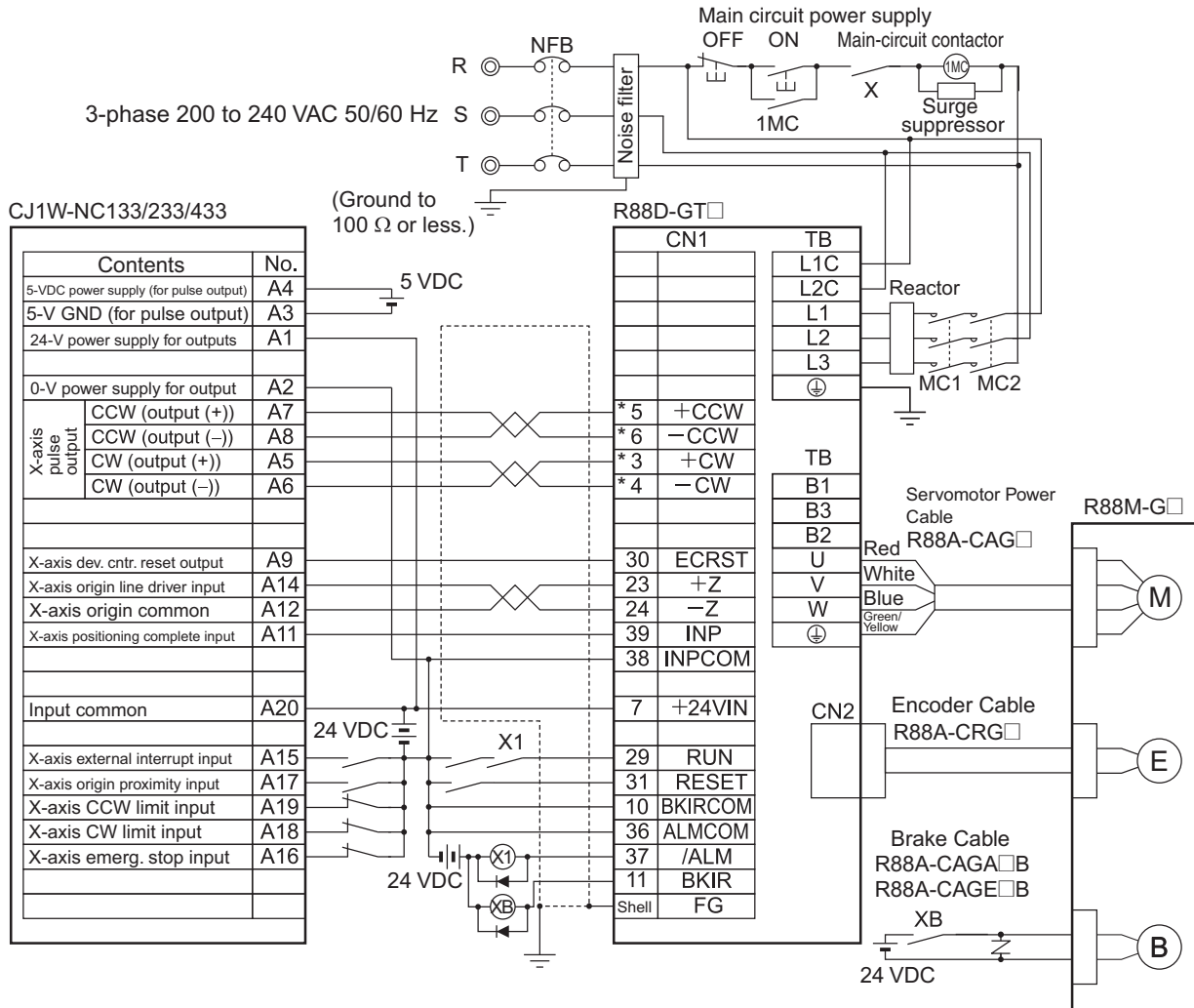

### Precautions for Correct Use

- The wiring for the pins with \* is the same as it is when a Servo Relay Unit Cable is used. Set Pn40 (Command Pulse Input Selection) to 0 (photocoupler input).
- The example shows a three-phase, 200-VAC input to the Servo Drive for the main circuit power supply. Be sure to provide a power supply and wiring conforming to the power supply specifications for the Servo Drive in use.
- Incorrect signal wiring can cause damage to Units and the Servo Drive.
- Leave unused signal lines open and do not wire them.
- Use mode 2 for origin search.
- The diode recommended for surge absorption is the RU 2 manufactured by Sanken Electric or the equivalent.
- Make the setting so that the Servo can be turned ON and OFF with the RUN signal.

Appendix 9

■ Connection Example 2: Connecting to SYSMAC CJ1W-NC113/213/413

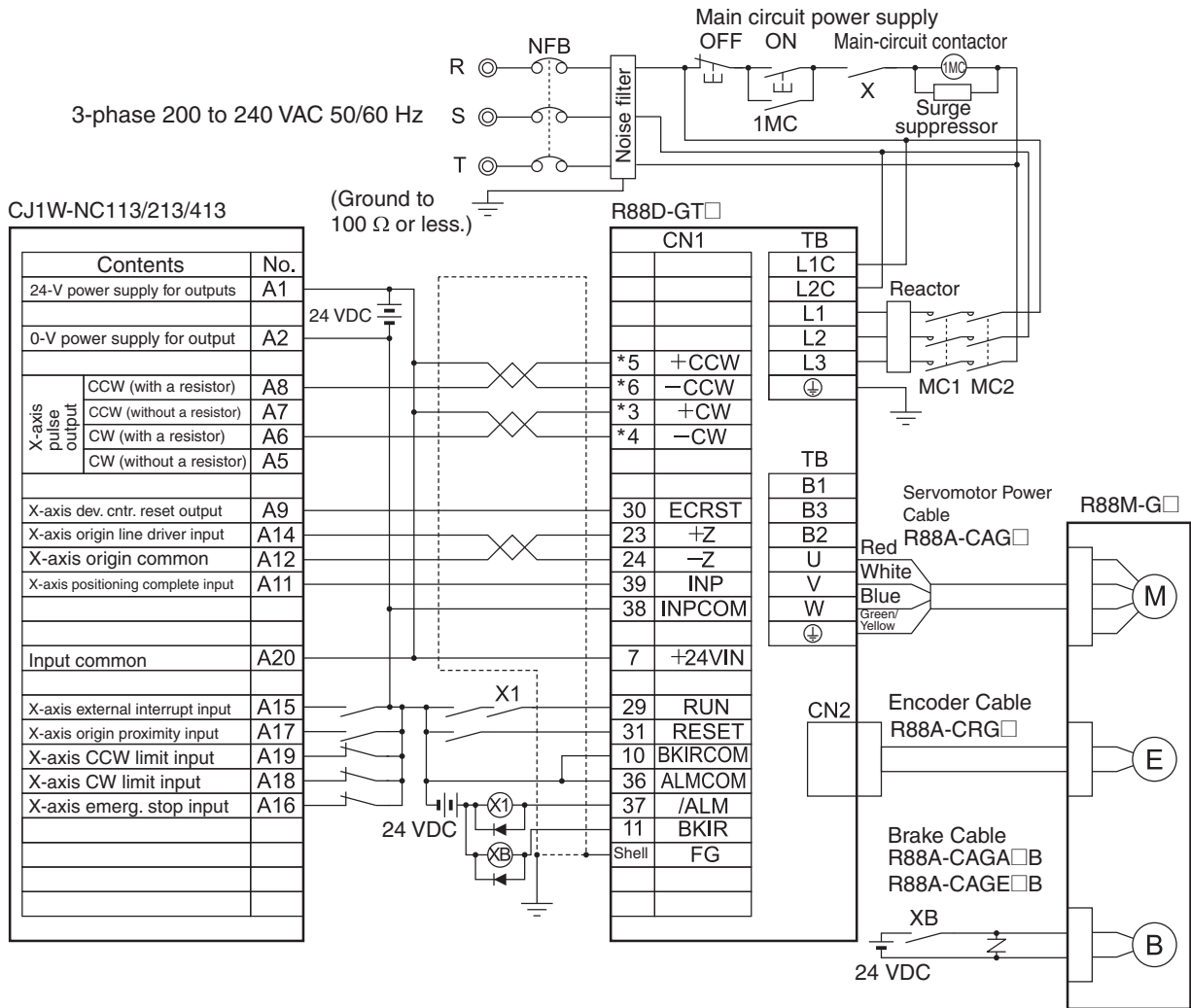

**Precautions for Correct Use**

- The wiring for the pins with \* is the same as it is when a Servo Relay Unit Cable is used. Set Pn40 (Command Pulse Input Selection) to 0 (photocoupler input).
- The example shows a three-phase, 200-VAC input to the Servo Drive for the main circuit power supply. Be sure to provide a power supply and wiring conforming to the power supply specifications for the Servo Drive in use.
- Incorrect signal wiring can cause damage to Units and the Servo Drive.
- Leave unused signal lines open and do not wire them.
- Use mode 2 for origin search.
- The diode recommended for surge absorption is the RU 2 manufactured by Sanken Electric or the equivalent.
- Make the setting so that the Servo can be turned ON and OFF with the RUN signal.

■ Connection Example 3: Connecting to SYSMAC CS1W-NC133/233/433

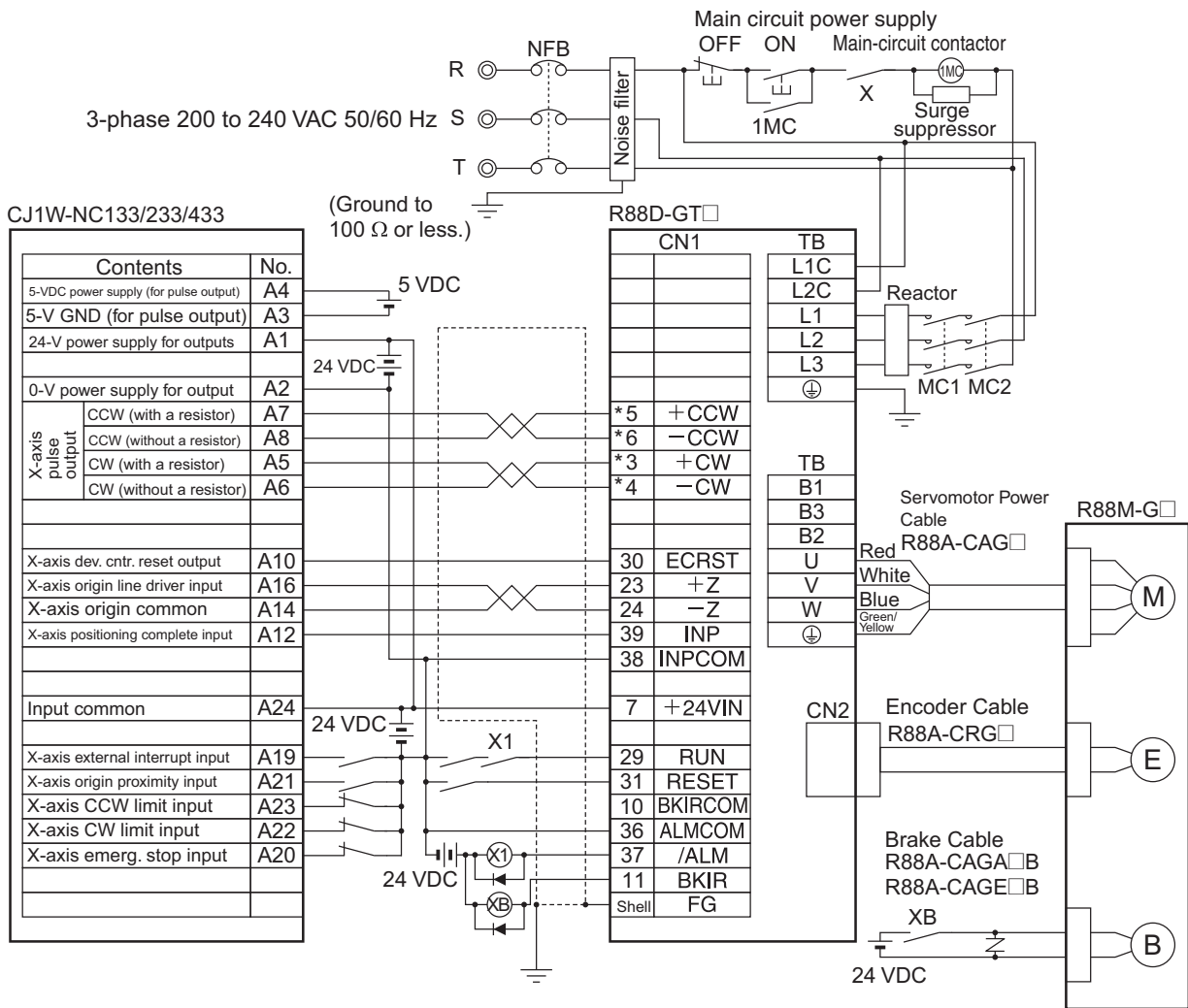

**Precautions for Correct Use**

- The wiring for the pins with \* is the same as it is when a Servo Relay Unit Cable is used. Set Pn40 (Command Pulse Input Selection) to 0 (photocoupler input).
- The example shows a three-phase, 200-VAC input to the Servo Drive for the main circuit power supply. Be sure to provide a power supply and wiring conforming to the power supply specifications for the Servo Drive in use.
- Incorrect signal wiring can cause damage to Units and the Servo Drive.
- Leave unused signal lines open and do not wire them.
- Use mode 2 for origin search.
- The diode recommended for surge absorption is the RU 2 manufactured by Sanken Electric or the equivalent.
- Make the setting so that the Servo can be turned ON and OFF with the RUN signal.



■ Connection Example 4: Connecting to SYSMAC CS1W-NC113/213/413 or C200HW-NC113/213/413

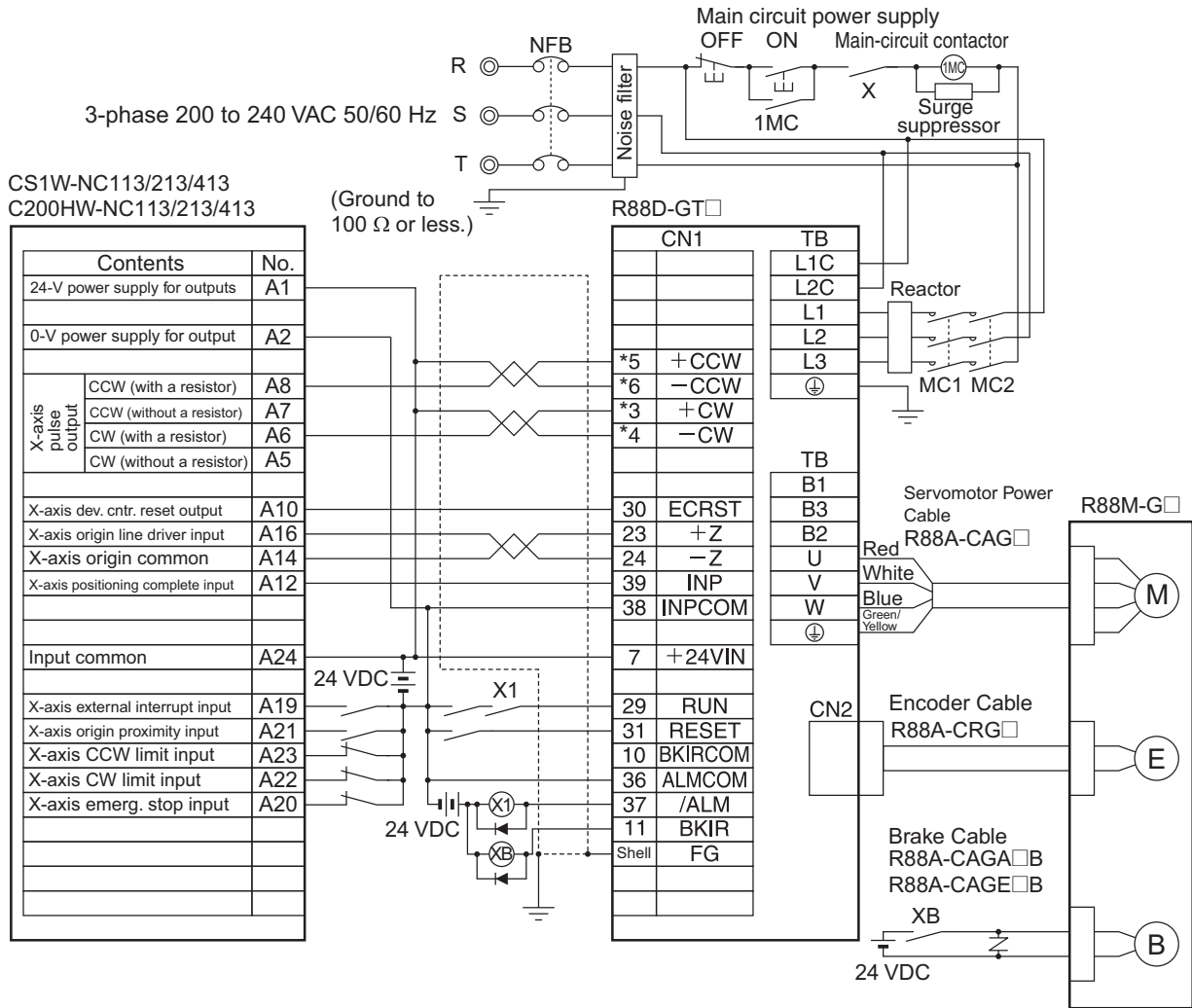

**Precautions for Correct Use**

- The wiring for the pins with \* is the same as it is when a Servo Relay Unit Cable is used. Set Pn40 (Command Pulse Input Selection) to 0 (photocoupler input).
- The example shows a three-phase, 200-VAC input to the Servo Drive for the main circuit power supply. Be sure to provide a power supply and wiring conforming to the power supply specifications for the Servo Drive in use.
- Incorrect signal wiring can cause damage to Units and the Servo Drive.
- Leave unused signal lines open and do not wire them.
- Use mode 2 for origin search.
- The diode recommended for surge absorption is the RU 2 manufactured by Sanken Electric or the equivalent.
- Make the setting so that the Servo can be turned ON and OFF with the RUN signal.

■ Connection Example 5: Connecting to a SYSMAC Motion Control Unit

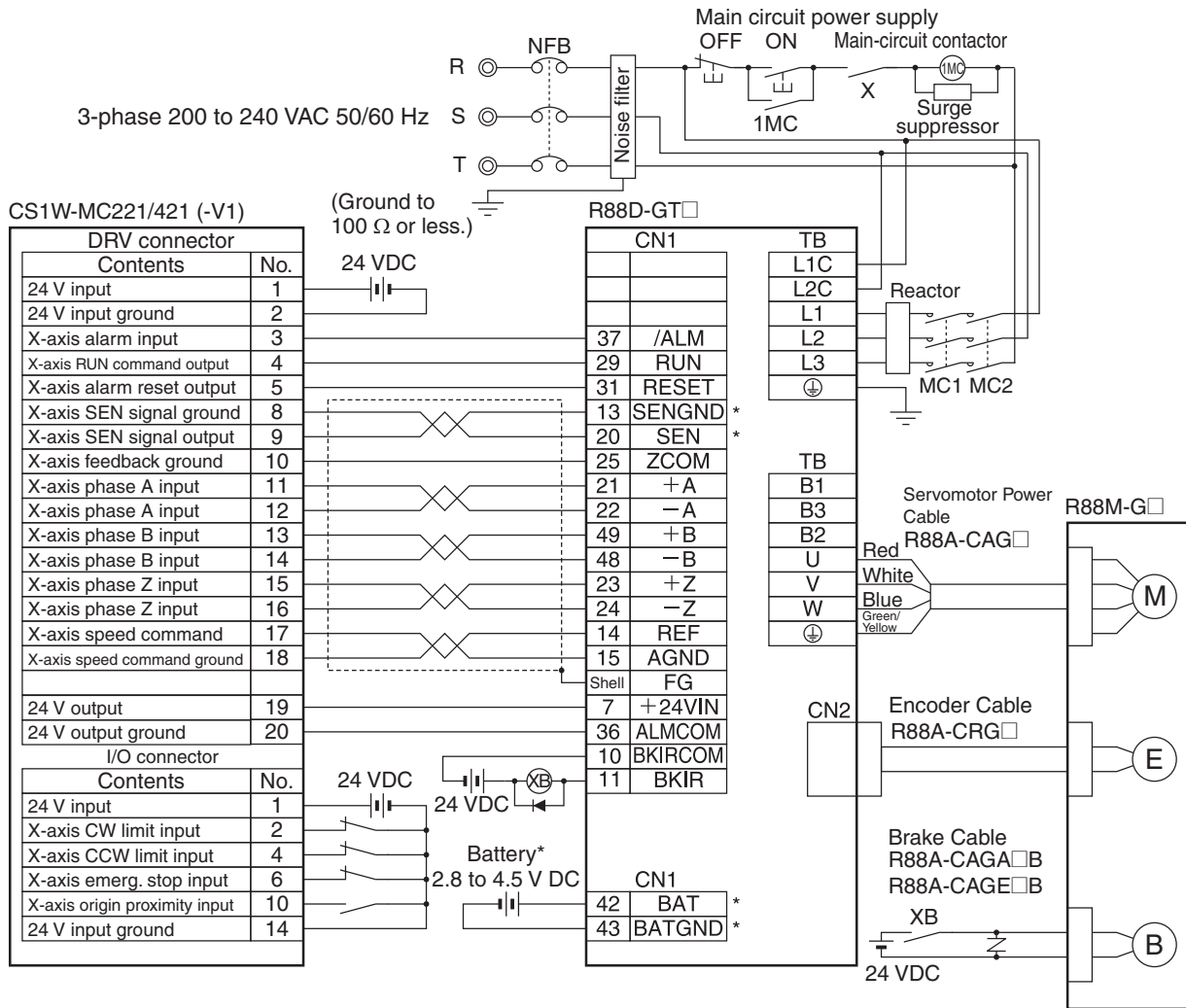

**Precautions for Correct Use**

- The example shows a three-phase, 200-VAC input to the Servo Drive for the main circuit power supply. Be sure to provide a power supply and wiring conforming to the power supply specifications for the Servo Drive in use.
- Incorrect signal wiring can cause damage to Units and the Servo Drive.
- Leave unused signal lines open and do not wire them.
- Connect terminals and wiring marked with an asterisk (\*) when using an Absolute Encoder.
- This wiring diagram is an example of X-axis wiring only. For other axes, connections must be made in the same way with the Servo Drive.
- Always close unused NC input terminals at the Motion Control Unit's I/O connectors.
- Make the setting so that the Servo can be turned ON and OFF with the RUN signal.

■ Connection Example 6: Connecting to SYSMAC CP1H-Y□□DT-D

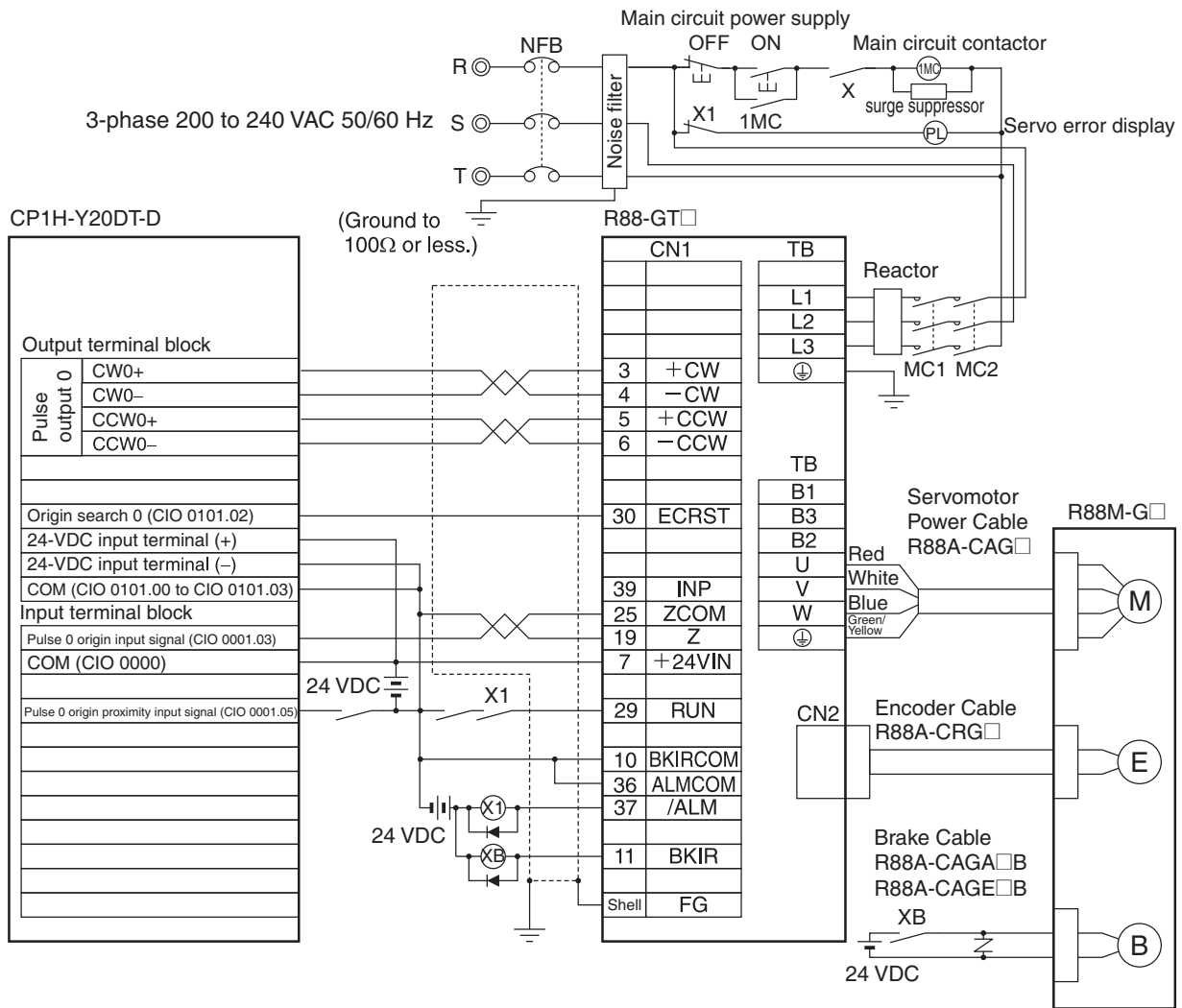

**Precautions for Correct Use**

- Incorrect signal wiring can cause damage to Units and the Servo Drive.
- Leave unused signal lines open and do not wire them.
- Do not share the power supply for brakes (24 VDC) with the 24-VDC power supply for controls.
- The diode recommended for surge absorption is the RU 2 manufactured by Sanken Electric or the equivalent.



■ Connection Example 8: Connecting to SYSMAC CJ1M

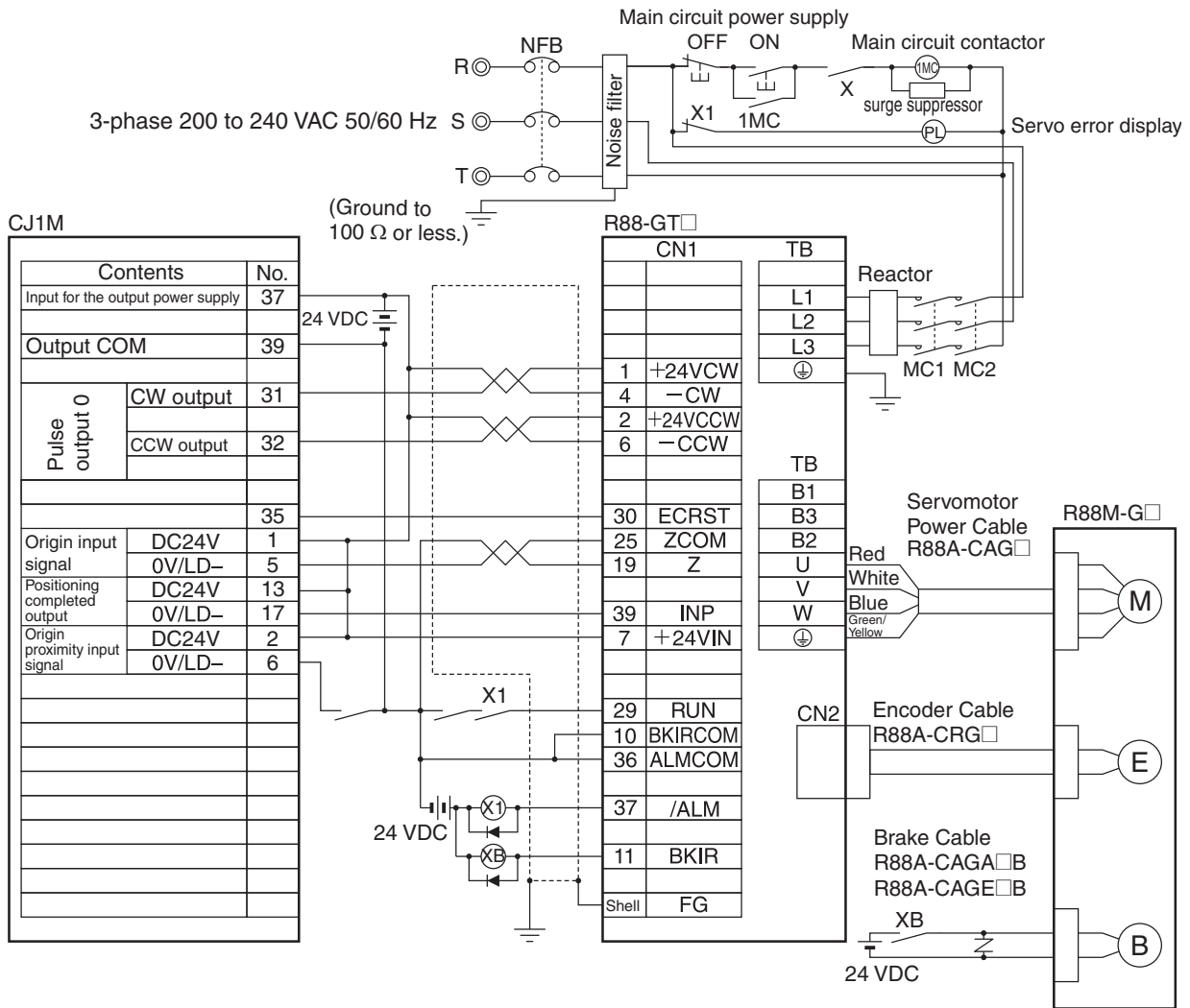

**Precautions for Correct Use**

- Incorrect signal wiring can cause damage to Units and the Servo Drive.
- Leave unused signal lines open and do not wire them.
- Use mode 2 for origin search.
- Use the 24-VDC power supply for command pulse signals as a dedicated power supply.
- Do not share the power supply for brakes (24 VDC) with the 24-VDC power supply for controls.
- The diode recommended for surge absorption is the RU 2 manufactured by Sanken Electric or the equivalent.

## 9-1 Connection Examples

### ■ Connection Example 9: Connecting to a SYSMAC CS1W-HCP22-V1 Customizable Counter Unit

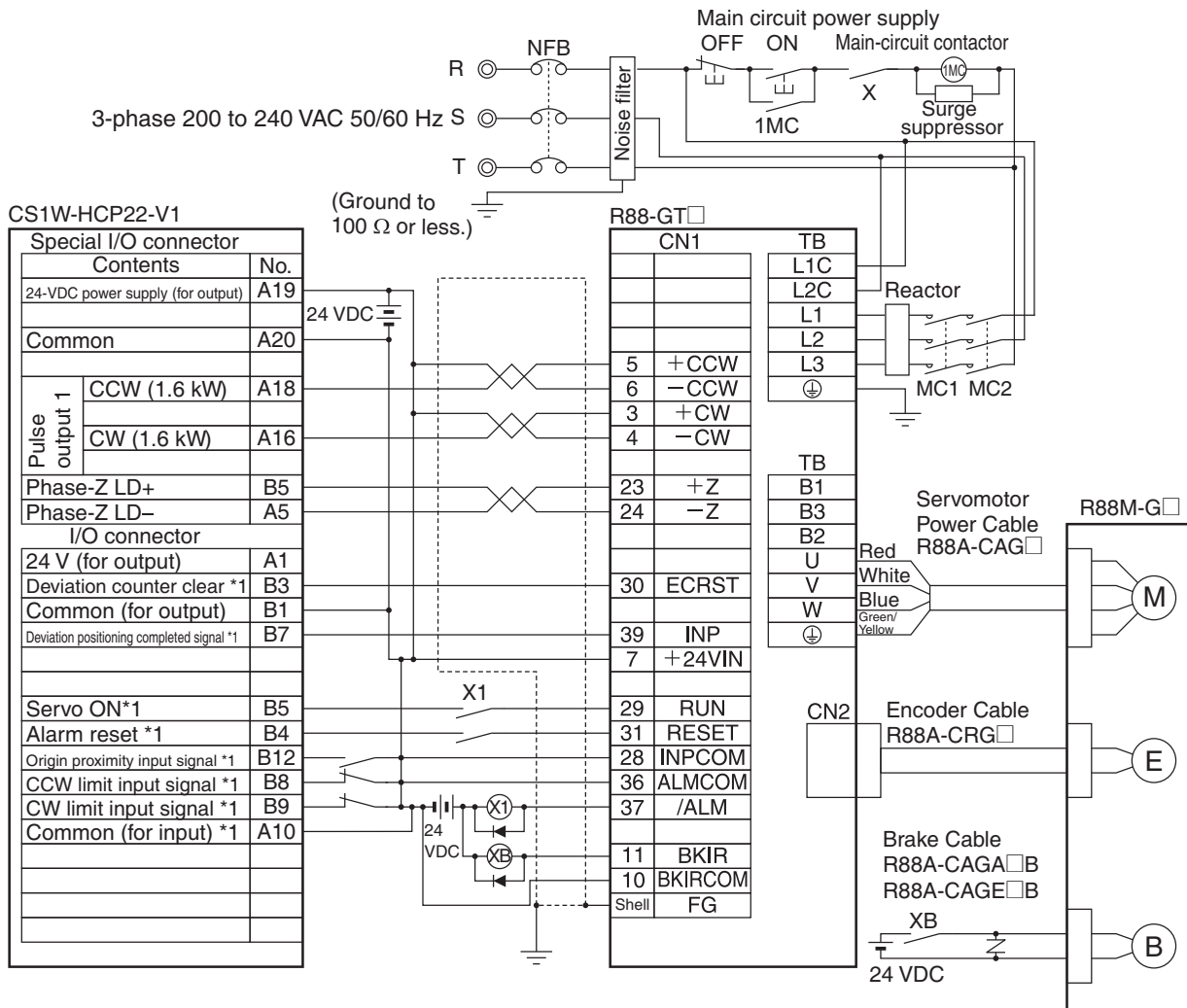

\*1. The I/O bits for the CS1W-HCP22 depend on the memory allocations in the CIO Area. Change the wiring according to the allocations.

#### Precautions for Correct Use

- Incorrect signal wiring can cause damage to Units and the Servo Drive.
- Leave unused signal lines open and do not wire them.
- Use the 24-VDC power supply for command pulse signals as a dedicated power supply.
- The diode recommended for surge absorption is the RU 2 manufactured by Sanken Electric or the equivalent.
- Do not share the power supply for brakes (24 VDC) with the 24-VDC power supply for controls.



# 9-2 Parameter Tables

- Some parameters are enabled by turning the power OFF and then ON again. (Those parameters are indicated in the table.) After changing these parameters, turn OFF the power, confirm that the power indicator has gone OFF, and then turn ON the power again.
- Do not change the parameters or settings marked “Reserved”.

## ■ Function Selection Parameters

Pn No.	Parameter name	Setting	Explanation	Default setting	Unit	Setting range	Power OFF→ON
00	Unit No. Setting	Set the unit number.		1	---	0 to 15	Yes
01	Default Display	Set the data to display on the Parameter Unit when the power supply is turned ON.		1		0 to 17	Yes
		0	Position deviation		Pulses		
		1	Servomotor rotation speed		r/min		
		2	Torque output		%		
		3	Control mode		---		
		4	I/O signal status		---		
		5	Alarm code and history		---		
		6	Software version		---		
		7	Warning display		---		
		8	Regeneration load ratio		%		
		9	Overload load ratio		%		
		10	Inertia ratio		%		
		11	Total feedback pulses		Pulses		
		12	Total command pulses		Pulses		
		13	Reserved		---		
		14	Reserved		---		
		15	Automatic Servomotor recognition display		---		
16	Analog input value	---					
17	Reason for no rotation	---					



Pn No.	Parameter name	Setting	Explanation	Default setting	Unit	Setting range	Power OFF→ON
02	Control Mode Selection	Set the control mode to be used.		0	---	0 to 6	Yes
		0	Position				
		1	Speed				
		2	Torque				
		3	Position/speed				
		4	Position/torque				
		5	Speed/torque				
		6	Reserved				
03	Torque Limit Selection	Set the torque limit method for forward and reverse operation.		1	---	0 to 3	---
		0	Use PCL and NCL as analog torque limit inputs.				
		1	Use Pn5E as the limit value for forward and reverse operation.				
		2	Forward: Use Pn5E, Reverse: Use Pn5F.				
		3	GSEL/TLSEL input is open: Use Pn5E, Input is closed: Use Pn5F.				
04	Drive Prohibit Input Selection	You can stop the Servomotor from rotating beyond the device's travel distance range by setting limit inputs.		1	---	0 to 2	Yes
		0	POT input and NOT input enabled.				
		1	POT input and NOT input disabled.				
		2	POT input and NOT input enabled (alarm code 38 appears).				
05	Command Speed Selection	Select the speed command when using speed control.		0	---	0 to 3	---
		0	Speed command input (REF)				
		1	No. 1 Internally Set Speed to No. 4 Internally Set Speed (Pn53 to Pn56)				
		2	No. 1 Internally Set Speed to No. 3 Internally Set Speed (Pn53 to Pn55) and External Speed Command (REF)				
		3	No. 1 Internally Set Speed to No. 8 Internally Set Speed (Pn53 to Pn56 and Pn74 to Pn77)				
06	Zero Speed Designation/Speed Command Direction Switch	Set the function of the Zero-speed Designation Input (VZERO).		0	---	0 to 2	---
		0	The zero-speed designation input will be ignored, and a zero-speed designation will not be detected.				
		1	The zero-speed designation input will be enabled, and the speed command will be assumed to be zero when the connection between the input and common is open.				
		2	Used as the speed command sign.				

## 9-2 Parameter Tables

Pn No.	Parameter name	Setting	Explanation	Default setting	Unit	Setting range	Power OFF→ ON
07	SP Selection		Select the relation between the output voltage level and the speed.	3	---	0 to 9	---
		0	Actual Servomotor speed: 6 V/47 r/min				
		1	Actual Servomotor speed: 6 V/188 r/min				
		2	Actual Servomotor speed: 6 V/750 r/min				
		3	Actual Servomotor speed: 6 V/3000 r/min				
		4	Actual Servomotor speed: 1.5 V/3000 r/min				
		5	Command speed: 6 V/47 r/min				
		6	Command speed: 6 V/188 r/min				
		7	Command speed: 6 V/750 r/min				
		8	Command speed: 6 V/3000 r/min				
		9	Command speed: 1.5 V/3000 r/min				
08	IM Selection		Select the relation between the output voltage level and the torque or number of pulses.	0	---	0 to 12	---
		0	Torque command: 3 V/rated (100%) torque				
		1	Position deviation: 3 V/31 pulses				
		2	Position deviation: 3 V/125 pulses				
		3	Position deviation: 3 V/500 pulses				
		4	Position deviation: 3 V/2000 pulses				
		5	Position deviation: 3 V/8000 pulses				
		6	Reserved				
		7	Reserved				
		8	Reserved				
		9	Reserved				
		10	Reserved				
		11	Torque command: 3 V/200% torque				
12	Torque command: 3 V/400% torque						

Pn No.	Parameter name	Setting	Explanation	Default setting	Unit	Setting range	Power OFF→ON
09	General-purpose Output 2 Selection	Assign the function of General-purpose Output 2 (OUTM2).		0	---	0 to 8	---
		0	Output during torque limit				
		1	Zero speed detection output				
		2	Warning output for regeneration overload, overload, absolute encoder battery, or fan lock.				
		3	Regeneration overload warning output				
		4	Overload warning				
		5	Absolute encoder battery warning output				
		6	Fan lock warning output				
		7	Reserved				
		8	Speed conformity output				
0A	General-purpose Output 1 Selection	Assign the function of General-purpose Output 1 (OUTM1).		1	---	0 to 8	---
		0	Output during torque limit				
		1	Zero speed detection output				
		2	Warning output for regeneration overload, overload, absolute encoder battery, or fan lock.				
		3	Regeneration overload warning output				
		4	Overload warning				
		5	Absolute encoder battery warning output				
		6	Fan lock warning output				
		7	Reserved				
		8	Speed conformity output				
0B	Operation Switch When Using Absolute Encoder	Set the operating method for the 17-bit absolute encoder.		0	---	0 to 2	Yes
		0	Use as absolute encoder.				
		1	Use as incremental encoder.				
		2	Use as absolute encoder but ignore multi-turn counter overflow.				
0C	RS-232 Baud Rate Setting	Select the baud rate for the RS-232 port.		2	---	0 to 5	Yes
		0	2,400 bps				
		1	4,800 bps				
		2	9,600 bps				
		3	19,200 bps				
		4	38,400 bps				
		5	57,600 bps				

## 9-2 Parameter Tables

Pn No.	Parameter name	Setting	Explanation	Default setting	Unit	Setting range	Power OFF→ON
0D	RS-485 Baud Rate Setting		Select the baud rate for RS-485 communications.	2	---	0 to 5	Yes
		0	2,400 bps				
		1	4,800 bps				
		2	9,600 bps				
		3	19,200 bps				
		4	38,400 bps				
		5	57,600 bps				
0E	Front Key Protection Setting		Front panel key operation can be limited to Monitor Mode.	0	---	0 to 1	Yes
		0	All enabled				
		1	Limited to Monitor Mode				
0F	Reserved		(Do not change setting.)	---	---	---	---

## ■ Gain Parameters

Pn No.	Parameter name	Setting	Explanation	Default setting	Unit	Setting range	Power OFF→ON
10	Position Loop Gain		Set to adjust position control system responsiveness.	40	1/s	0 to 3000	---
11	Speed Loop Gain		Set to adjust speed loop responsiveness.	50	Hz	1 to 3500	---
12	Speed Loop Integration Time Constant		Set to adjust the speed loop integration time constant.	20	ms	1 to 1000	---
13	Speed Feedback Filter Time Constant		The encoder signal is converted to the speed signal via the low pass filter.	0	---	0 to 5	---
14	Torque Command Filter Time Constant		Set to adjust the first-order lag filter time constant for the torque command section.	80	0.01 ms	0 to 2500	---
15	Feed-forward Amount		Set the position control feed-forward compensation value.	300	0.1%	-2000 to 2000	---
16	Feed-forward Command Filter		Set the time constant of the first-order lag filter used in the speed feed-forward section.	100	0.01 ms	0 to 6400	---
17	Reserved		(Do not change setting.)	---	---	---	---
18	Position Loop Gain 2		Set to adjust position control system responsiveness.	20	1/s	0 to 3000	---
19	Speed Loop Gain 2		Set to adjust speed loop responsiveness.	80	Hz	1 to 3500	---
1A	Speed Loop Integration Time Constant 2		Set to adjust the speed loop integration time constant.	50	ms	1 to 1000	---
1B	Speed Feedback Filter Time Constant 2		The encoder signal is converted to the speed signal via the low pass filter.	0	---	0 to 5	---
1C	Torque Command Filter Time Constant 2		Set to adjust the first-order lag filter time constant for the torque command section.	100	0.01 ms	0 to 2500	---
1D	Notch Filter 1 Frequency		Set the notch frequency of the resonance suppression notch filter.	1500	Hz	100 to 1500	---
1E	Notch Filter 1 Width		Set the width to one of five levels for the resonance suppression notch filter. Normally, use the default setting.	2	---	0 to 4	---
1F	Reserved		(Do not change setting.)	---	---	---	---
20	Inertia Ratio		Set the ratio between the mechanical system inertia and the Servomotor rotor inertia.	300	%	0 to 10000	---

## 9-2 Parameter Tables

Pn No.	Parameter name	Setting	Explanation	Default setting	Unit	Setting range	Power OFF→ON
21	Realtime Autotuning Mode Selection		Set the operating mode for realtime autotuning.	0	---	0 to 7	---
		0	Realtime autotuning is not used.				
		1	Realtime autotuning is used in normal mode. Use this setting if there are almost no changes in load inertia during operation.				
		2	Realtime autotuning is used in normal mode. Use this setting if there are gradual changes in load inertia during operation.				
		3	Realtime autotuning is used in normal mode. Use this setting if there are sudden changes in load inertia during operation.				
		4	Realtime autotuning is used in vertical axis mode. Use this setting if there are almost no changes in load inertia during operation.				
		5	Realtime autotuning is used in vertical axis mode. Use this setting if there are gradual changes in load inertia during operation.				
		6	Realtime autotuning is used in vertical axis mode. Use this setting if there are sudden changes in load inertia during operation.				
		7	Set to use realtime autotuning without switching the gain.				
22	Realtime Autotuning Machine Rigidity Selection		Set the machine rigidity to one of 16 levels during realtime autotuning. The higher the machine rigidity, the greater the setting needs to be. The higher the setting, the higher the responsiveness. When the Parameter Unit is used, 0 cannot be set.	2	---	0 to F	---
23	Adaptive Filter Selection		Enable or disable the adaptive filter.	0	---	0 to 2	---
		0	Adaptive filter disabled.				
		1	Adaptive filter enabled. Adaptive operation performed.				
		2	Adaptive filter enabled. Adaptive operation will not be performed (i.e., it will be held).				
24	Vibration Filter Selection		Vibration filters 1 and 2 can be switched.	0	---	0 to 2	---
		0	No switching. (Both filter 1 and filter 2 are enabled.)				
		1	Switching with the DFSEL/PNSEL input. Open: Vibration filter 1 Closed: Vibration filter 2				
		2	Switching with command direction. Forward: Vibration filter 1 Reverse: Vibration filter 2				

Pn No.	Parameter name	Setting	Explanation	Default setting	Unit	Setting range	Power OFF→ON
25	Autotuning Operation Setting	Set the operating pattern for normal mode autotuning.		0	---	0 to 7	---
		0	Rotation direction: Forward to reverse, two rotations				
		1	Rotation direction: Reverse to forward, two rotations				
		2	Rotation direction: Forward to forward, two rotations				
		3	Rotation direction: Reverse to reverse, two rotations				
		4	Rotation direction: Forward to reverse, one rotation				
		5	Rotation direction: Reverse to forward, one rotation				
		6	Rotation direction: Forward to forward, one rotation				
		7	Rotation direction: Reverse to reverse, one rotation				
26	Overrun Limit Setting	Set the allowable operating range for the Servomotor. The overrun limit function is disabled if the parameter is set to 0.		10	0.1 rotation	0 to 1000	---
27	Instantaneous Speed Observer Setting	Set the instantaneous speed observer.		0	---	0 to 1	---
		0	Disabled				
		1	Enabled				
28	Notch Filter 2 Frequency	Set the notch frequency of the resonance suppression notch filter.		1500	Hz	100 to 1500	---
29	Notch Filter 2 Width	Set the notch filter width to one of five levels for the resonance suppression notch filter. Normally, use the default setting.		2	---	0 to 4	---
2A	Notch Filter 2 Depth	Set the depth of the resonance suppression notch filter.		0	---	0 to 99	---
2B	Vibration Frequency 1	Set vibration frequency 1 to suppress vibration at the end of the load in damping control.		0	0.1 Hz	0 to 2000	---
2C	Vibration Filter 1 Setting	Set vibration filter 1 to suppress vibration at the end of the load in damping control.		0	0.1 Hz	-200 to 2000	---
2D	Vibration Frequency 2	Set vibration frequency 2 to suppress vibration at the end of the load in damping control.		0	0.1 Hz	0 to 2000	---
2E	Vibration Filter 2 Setting	Set vibration filter 2 to suppress vibration at the end of the load in damping control.		0	0.1 Hz	-200 to 2000	---
2F	Adaptive Filter Table Number Display	Displays the table entry number corresponding to the frequency for the adaptive filter. This parameter is set automatically and cannot be changed if the adaptive filter is enabled (i.e., if Real-time Autotuning Mode Selection (Pn21) is 1 to 3 or 7).		0	---	0 to 64	---

## 9-2 Parameter Tables

Pn No.	Parameter name	Setting	Explanation	Default setting	Unit	Setting range	Power OFF→ON
30	Gain Switching Input Operating Mode Selection		Enable or disable gain switching. If gain switching is enabled, the setting of the Control Gain Switch Setting (Pn31) is used as the condition for switching between gain 1 and gain 2.	1	---	0 to 1	---
		0	Disabled. The gain set in Pn10 to Pn14 is used, and the Gain Switching Input (GSEL) will be used to switch between PI operation and P operation.				
		1	Enabled. The gain will be switched between gain 1 (Pn10 to Pn14) and gain 2 (Pn18 to Pn1C).				
31	Control Gain Switch 1 Setting		Select the condition for switching between gain 1 and gain 2. The details depend on the control mode. If a composite mode is set, the setting of this parameter is valid when the first control mode is used. The Gain Switching Input Operating Mode Selection (Pn30) must be set to 1 (enabled).	0	---	0 to 10	---
		0	Always gain 1				
		1	Always gain 2				
		2	Switching using Gain Switching Input (GSEL)				
		3	Amount of change in torque command				
		4	Always gain 1				
		5	Command speed				
		6	Amount of position deviation				
		7	Command pulses received				
		8	Positioning Completed Signal (INP) OFF				
		9	Actual Servomotor speed				
10	Combination of command pulse input and speed						
32	Gain Switch 1 Time		This parameter is enabled when the Control Gain Switch 1 Setting (Pn31) is 3 to 10. Set the delay time from the moment the condition set in the Control Gain Switch 1 Setting (Pn31) is not met until returning to gain 1.	30	166 μs	0 to 10000	---
33	Gain Switch 1 Level Setting		This parameter is enabled when the Control Gain Switch 1 Setting (Pn31) is 3 to 6, 9, or 10. Set the judgment level for switching between gain 1 and gain 2. The unit for the setting depends on the condition set in the Control Gain Switch 1 Setting (Pn31).	600	---	0 to 20000	---
34	Gain Switch 1 Hysteresis Setting		Set the hysteresis width above and below the judgment level set in the Gain Switch 1 Level Setting (Pn33).	50	---	0 to 20000	---
35	Position Loop Gain Switching Time		When switching between gain 1 and gain 2 is enabled, set the phased switching time only for the position loop gain at gain switching.	20	166 μs	0 to 10000	---



Pn No.	Parameter name	Setting	Explanation	Default setting	Unit	Setting range	Power OFF→ON
36	Control Gain Switch 2 Setting	Select the condition for switching between gain 1 and gain 2 in the second control mode. The Gain Switching Input Operating Mode Selection (Pn30) must be set to 1 (enabled).		0	---	0 to 5	---
		0	Always gain 1				
		1	Always gain 2				
		2	Switching using gain switching input (GSEL)				
		3	Amount of change in torque command				
		4	Amount of change in speed command				
		5	Command speed				
37	Gain Switch 2 Time	This parameter is enabled when Control Gain Switch 2 Setting (Pn36) is 3 to 5. Set the delay time for returning from gain 2 to gain 1.		30	166 μs	0 to 10000	---
38	Gain Switch 2 Level Setting	This parameter is enabled when Control Gain Switch 2 Setting (Pn36) is 3 to 5. Set the judgment level for switching between gain 1 and gain 2. The unit depends on the setting of Control Gain Switch 2 Setting (Pn36).		0	---	0 to 20000	---
39	Gain Switch 2 Hysteresis Setting	Set the hysteresis width above and below the judgment level set in the Gain Switch 2 Level Setting (Pn38). The unit depends on the setting of the Control Gain Switch 2 Setting (Pn36).		0	---	0 to 20000	---
3A	Reserved	(Do not change setting.)		---	---	---	---
3B	Reserved	(Do not change setting.)		---	---	---	---
3C	Reserved	(Do not change setting.)		---	---	---	---
3D	Jog Speed	Set the speed for jogging.		200	r/min	0 to 500	---
3E	Reserved	(Do not change setting.)		---	---	---	---
3F	Reserved	(Do not change setting.)		---	---	---	---

■ Position Control Parameters

Pn No.	Parameter name	Setting	Explanation	Default setting	Unit	Setting range	Power OFF→ON
40	Command Pulse Input Selection	Selects whether to use photocoupler or line-driver-only input for the command pulse input. When using a Servo Relay Unit cable, set to 0 (photocoupler input).		0	---	0 to 1	Yes
		0	Photocoupler				
		1	Input for line driver only				
41	Command Pulse Rotation Direction Switch	Set the Servomotor rotation direction for the command pulse input.		0	---	0 to 1	Yes
		0	The Servomotor rotates in the direction specified by the command pulse.				
		1	The Servomotor rotates in the opposite direction from the direction specified by the command pulse.				
42	Command Pulse Mode	Set the form of the pulse inputs sent as command to the Servo Drive from a position controller.		1	---	0 to 3	Yes
		0	90° phase difference (phase A/B) signal inputs				
		1	Forward pulse and reverse pulse inputs				
		2	90° phase difference (phase A/B) signal inputs				
		3	Feed pulses and forward/reverse signal input				
43	Command Pulse Prohibited Input Setting	Enable or disable the pulse disable input (IPG).		1	---	0 to 1	---
		0	Enabled				
		1	Disabled				
44	Encoder Divider Numerator Setting	Set the number of encoder pulses (+A, -A, -B, +B) output from the Servo Drive for each Servomotor rotation.		2500	---	1 to 32767	Yes
45	Encoder Divider Denominator Setting			0	---	0 to 32767	Yes
46	Encoder Output Direction Switch	Set the phase-B logic for pulse output (-B, +B).		0	---	0 to 1	Yes
		0	Phase-B output: Not reversed.				
		1	Phase-B output: Reversed.				
47	Reserved	(Do not change setting.)		---	---	---	---

Pn No.	Parameter name	Setting	Explanation	Default setting	Unit	Setting range	Power OFF→ON
48	Electronic Gear Ratio Numerator 1	Set the pulse rate for command pulses and Servomotor travel distance. If Pn48 or Pn49 is 0, the encoder resolution is set to a numerator.  $\frac{\text{Electronic Gear Ratio Numerator 1 (Pn48) \quad \text{Electronic Gear Ratio Numerator Exponent (Pn4A)} \times 2}{\text{Electronic Gear Ratio Numerator 2 (Pn49)}}$ Electronic Gear Ratio Denominator (Pn4B)		0	---	0 to 10000	---
49	Electronic Gear Ratio Numerator 2			0	---	0 to 10000	---
4A	Electronic Gear Ratio Numerator Exponent			0	---	0 to 17	---
4B	Electronic Gear Ratio Denominator			10000	---	1 to 10000	---
4C	Position Command Filter Time Constant Setting		Set the time constant for the first-order lag filter for the command pulse input. If the parameter is set to 0, the filter will not function. The larger the setting, the larger the time constant.	0	---	0 to 7	---
4D	Smoothing Filter Setting		Select the FIR filter time constant used for the command pulse input. The higher the setting, the smoother the command pulses.	0	---	0 to 31	Yes
4E	Deviation Counter Reset Condition Setting		Set the deviation counter reset conditions.	1	---	0 to 2	---
		0	Clears the deviation counter when the signal is closed for 100 μs or longer.				
		1	Clears the deviation counter on the falling edge of the signal (open and then closed for 100 μs or longer).				
	2	Disabled					
4F	Reserved		(Do not change setting.)	---	---	---	---

■ Speed and Torque Control Parameters

Pn No.	Parameter name	Setting	Explanation	Default setting	Unit	Setting range	Power OFF→ON
50	Speed Command Scale		Set the relation between the voltage applied to the Speed Command Input (REF) and the Servomotor speed.	300	(r/min) /V	10 to 2000	---
51	Command Speed Rotation Direction Switch		Set to reverse the polarity of the speed command input (REF).	0	---	0 to 1	---
		0	Forward				
		1	Reverse				
52	Speed Command Offset Adjustment		Set to adjust the offset of the Speed Command Input (REF).	0	0.3 mV	-2047 to 2047	---
53	No. 1 Internally Set Speed		Set the No. 1 internally set rotation speed.	100	r/min	-20000 to 20000	---
54	No. 2 Internally Set Speed		Set the No. 2 internally set rotation speed.	200	r/min	-20000 to 20000	---
55	No. 3 Internally Set Speed		Set the No. 3 internally set rotation speed.	300	r/min	-20000 to 20000	---
56	No. 4 Internally Set Speed		Set the No. 4 internally set rotation speed. For torque control (when Pn5B = 0), set the speed limit.	50	r/min	-20000 to 20000	---
74	No. 5 Internally Set Speed		Set the No. 5 internally set rotation speed.	500	r/min	-20000 to 20000	---
75	No. 6 Internally Set Speed		Set the No. 6 internally set rotation speed.	600	r/min	-20000 to 20000	---
76	No. 7 Internally Set Speed		Set the No. 7 internally set rotation speed.	700	r/min	-20000 to 20000	---
77	No. 8 Internally Set Speed		Set the No. 8 internally set rotation speed.	800	r/min	-20000 to 20000	---
57	Speed Command Filter Time Constant		Set the first-order lag filter time constant in the Speed Command Input (REF: CN1 pin 14).	0	0.01 ms	0 to 6400	---
58	Soft Start Acceleration Time		Set the acceleration time for the speed command.	0	2 ms (1000 r/min)	0 to 5000	---
59	Soft Start Deceleration Time		Set the deceleration time for the speed command.	0	2 ms (1000 r/min)	0 to 5000	---

Pn No.	Parameter name	Setting	Explanation	Default setting	Unit	Setting range	Power OFF→ON
5A	S-curve Acceleration/Deceleration Time Setting		Set the pseudo-S-curve acceleration/deceleration value to add to the speed command to enable smooth operation.	0	2 ms	0 to 500	---
5B	Torque Command/Speed Limit Selection		Select the input for the torque command and speed limit. For the settings and control mode, refer to the description of the <i>Torque Command/Speed Limit Selection</i> on page 5-84.	0	---	0 to 1	---
5C	Torque Command Scale		Set the relation between the voltage applied to the Speed Limit Input (VLIM) and the Servomotor speed.	30	0.1 V/100%	10 to 100	---
5D	Torque Output Direction Switch	Set to reverse the polarity of the Torque Command Input (REF/TREF1 or PCL/TREF2).		0	---	0 to 1	---
		0	Forward				
		1	Reverse				
5E	No. 1 Torque Limit		Set the limit to the Servomotor's maximum torque.	300	%	0 to 500	---
5F	No. 2 Torque Limit		Set the limit to the Servomotor's maximum torque.	100	%	0 to 500	---

■ Sequence Parameters

Pn No.	Parameter name	Setting	Explanation	Default setting	Unit	Setting range	Power OFF→ON
60	Positioning Completion Range		Set the range for the Positioning Completed Output (INP).	25	Pulse	0 to 32767	---
61	Zero Speed Detection		Set the rotation speed to output for the general-purpose output (zero speed detection output or speed coincidence output).	20	r/min	10 to 20000	---
62	Rotation Speed for Motor Rotation Detection		Set the rotation speed for the Servomotor Rotation Detection Output (TGON) for Internally Set Speed Control.	50	r/min	10 to 20000	---
63	Positioning Completion Condition Setting		Set the operation for positioning completion output (INP).	0	---	0 to 3	---
		0	Positioning completion output turns ON when the position deviation is within the Positioning Completion Range (Pn60).				
		1	Positioning completion output turns ON when the position deviation is within the Positioning Completion Range (Pn60) and there is no position command.				
		2	Positioning completion output turns ON when the zero speed detection signal is ON and the position deviation is within the Positioning Completion Range (Pn60) and there is no position command.				
		3	Positioning completion output turns ON when the position deviation is within the Positioning Completion Range (Pn60) and there is no position command. The ON status will then be held until the next position command is received.				
64	Reserved		(Do not change setting.)	---	---	---	---
65	Undervoltage Alarm Selection		Select whether to activate the main power supply undervoltage function (alarm code 13) if the main power supply is interrupted for the Momentary Hold Time (Pn6D) during Servo ON.	1	---	0 to 1	---
		0	A main power supply undervoltage alarm (alarm code 13) is not generated and the Servomotor turns OFF. When the main power supply turns ON again, the Servo ON status returns.				
		1	An error is generated for a main power supply undervoltage alarm (alarm code 13).				

Pn No.	Parameter name	Setting	Explanation	Default setting	Unit	Setting range	Power OFF→ON
66	Stop Selection for Drive Prohibition Input		Set the operation used to decelerate to a stop after the Forward Drive Prohibit Input (POT) or Reverse Drive Prohibit Input (NOT) has been received.	0	---	0 to 2	Yes
		0	The torque in the drive prohibit direction is disabled, and the dynamic brake is activated.				
		1	The torque in the drive prohibit direction is disabled, and free-run deceleration is performed.				
		2	The torque in the drive prohibit direction is disabled, and an emergency stop is performed.				
67	Stop Selection with Main Power OFF		Set one of the following operations to be performed after the main power supply is cut off if the Undervoltage Alarm Selection (Pn65) is set to 0. ♦ Operation during deceleration and after stopping ♦ Clearing the deviation counter	0	---	0 to 9	---
		0	During deceleration: Dynamic brake After stopping: Dynamic brake Deviation counter: Clear				
		1	During deceleration: Free run After stopping: Dynamic brake Deviation counter: Clear				
		2	During deceleration: Dynamic brake After stopping: Servo free Deviation counter: Clear				
		3	During deceleration: Free run After stopping: Servo free Deviation counter: Clear				
		4	During deceleration: Dynamic brake After stopping: Dynamic brake Deviation counter: Hold				
		5	During deceleration: Free run After stopping: Dynamic brake Deviation counter: Hold				
		6	During deceleration: Dynamic brake After stopping: Servo free Deviation counter: Hold				
		7	During deceleration: Free run After stopping: Servo free Deviation counter: Hold				
		8	During deceleration: Emergency stop After stopping: Dynamic brake Deviation counter: Clear				
		9	During deceleration: Emergency stop After stopping: Servo free Deviation counter: Clear				

## 9-2 Parameter Tables

Pn No.	Parameter name	Setting	Explanation	Default setting	Unit	Setting range	Power OFF→ON
68	Stop Selection for Alarm Generation		Set the operation to be performed after stopping or during deceleration when any protective function of the Servo Drive operates and an error occurs.	0	---	0 to 3	---
		0	During deceleration: Dynamic brake After stopping: Dynamic brake				
		1	During deceleration: Free run After stopping: Dynamic brake				
		2	During deceleration: Dynamic brake After stopping: Servo free				
		3	During deceleration: Free run After stopping: Servo free				
69	Stop Selection with Servo OFF		Set the operation to be performed after the Servomotor turns OFF (i.e., RUN ON to OFF). The relation between set values, operation, and deviation counter processing for this parameter is the same as for the Stop Selection with Main Power OFF (Pn67).	0	---	0 to 9	---
6A	Brake Timing when Stopped		When the Servomotor is stopped and the RUN Command Input (RUN) is turned OFF, the Brake Interlock Signal (BKIR) will turn OFF, and the Servomotor will turn OFF after waiting for the time period set for this parameter (i.e., setting × 2 ms).	10	2 ms	0 to 100	---
6B	Brake Timing during Operation		When the Servomotor is stopped and the RUN Command Input (RUN) is turned OFF, the Servomotor will decelerate to reduce rotation speed, and the Brake Interlock Signal (BKIR) will turn OFF after the set time for the parameter (i.e., setting × 2 ms) has elapsed. BKIR will also turn OFF if the speed drops to 30 r/min or lower before the set time elapses.	50	2 ms	0 to 100	---
6C	Regeneration Resistor Selection		Set whether to use a built-in resistor or to add an External Regeneration Resistor.	0	---	0 to 3	Yes
		0	Regeneration resistor used: Built-in resistor The regeneration processing circuit will operate and the regeneration overload (alarm code 18) will be enabled according to the internal resistance (with approximately 1% duty).				
		1	Regeneration resistor used: External resistor The regeneration processing circuit will operate, and regeneration overload (alarm code 18) will cause a trip when the operating rate of the regeneration resistor exceeds 10%.				
		2	Regeneration resistor used: External resistor The regeneration processing circuit will operate, but regeneration overload (alarm code 18) will not occur.				
		3	Regeneration resistor used: None The regeneration processing circuit and regeneration overload (alarm code 18) will not operate, and all regenerative energy will be processed by the built-in capacitor.				
6D	Momentary Hold Time		Set the amount of time required until shutoff is detected if the main power supply continues to shut off.	35	2 ms	35 to 1000	Yes



Pn No.	Parameter name	Setting	Explanation	Default setting	Unit	Setting range	Power OFF→ON
6E	Emergency Stop Torque		Set the torque limit for the following cases. ♦Drive prohibit deceleration with the Stop Selection for Drive Prohibition Input (Pn66) set to 2. ♦Deceleration with the Stop Selection with Main Power OFF (Pn67) set to 8 or 9. ♦Deceleration with the Stop Selection with Servo OFF (Pn69) set to 8 or 9.	0	%	0 to 500	---
6F	Reserved	(Do not change setting.)		---	---	---	---
70	Deviation Counter Overflow Level		Set the deviation counter overflow level.	100	× 256 pulses	0 to 32767	---
71	Speed Command/Torque Command Input Overflow Level Setting		Set the overflow level for Speed Command Input (REF) or Torque Command Input (TREF) using voltage after offset adjustment.	0	0.1 V	0 to 100	---
72	Overload Detection Level Setting		Set the overload detection level.	0	%	0 to 115	---
73	Overspeed Detection Level Setting		Set the overspeed detection level.	0	r/min	0 to 20000	---
78	Reserved	(Do not change setting.)		---	---	---	---
79	Reserved	(Do not change setting.)		---	---	---	---
7A	Reserved	(Do not change setting.)		---	---	---	---
7B	Reserved	(Do not change setting.)		---	---	---	---
7C	Reserved	(Do not change setting.)		---	---	---	---
7D	Reserved	(Do not change setting.)		---	---	---	---
7E	Reserved	(Do not change setting.)		---	---	---	---
7F	Reserved	(Do not change setting.)		---	---	---	---

# Index

## Numerics

1,000-r/min Servomotors .....	2-4, 3-43
12 to 24-VDC Power Supply Input (24VIN) .....	3-12
2,000-r/min Servomotors .....	2-3, 3-41
24-V Open-collector Input for Command Pulse (+24VCW) .....	3-12
3,000-r/min Flat Servomotors .....	2-3, 3-39
3,000-r/min Servomotors .....	2-2, 3-33
90-degree Phase Difference Pulse Input (Phase A) (FA) .....	3-12
90-degree Phase Difference Pulse Input (Phase B) (FB) .....	3-12

## A

Absolute Encoder Battery Cable .....	3-63, 2-20
Absolute Encoder Reset Mode .....	6-23
absolute encoder setup .....	6-5
absolute encoders .....	3-46
adaptive filter .....	7-11
Adaptive Filter Selection (Pn23) .....	5-64
Adaptive Filter Table Number Display (Pn2F) .....	5-67
Alarm Output (/ALM) .....	3-15, 3-29
Alarm Reset Input (RESET) .....	3-13, 3-25
Alarm Reset Mode .....	6-21
alarm table .....	8-4
allowable current .....	4-25
Analog Input Ground (AGND) .....	3-12
applicable standards .....	1-10
Automatic Offset Adjustment Mode .....	6-22
Autotuning Operation Setting (Pn25) .....	5-64
autotuning table .....	7-16

## B

Backup Battery Input (BAT) .....	3-14
Brake Cables .....	3-79
Brake Cables (Robot Cables) .....	2-20, 3-81
Brake Cables (Standard Cables) .....	2-17
brake interlock .....	5-21
Brake Interlock Output (BKIR) .....	3-15
Brake Timing during Operation (Pn6B) .....	5-91
Brake Timing When Stopped (Pn6A) .....	5-90

## C

cable specifications .....	3-57
changing the mode .....	6-7
check pins .....	1-4
clamp cores .....	4-37
Command Pulse Input Selection (Pn40) .....	5-74
Command Pulse Mode (Pn42) .....	5-75
Command Pulse Prohibited Input (Pn43) .....	5-75
Command Speed Rotation Direction Switch (Pn51) .....	5-81
Command Speed Selection (Pn05) .....	5-54
Communications Cables .....	2-20, 3-84, 3-85
communications connector specifications (CN3A) .....	3-31
Computer Monitor Cables .....	3-84, 4-14
connecting cables .....	4-11
connection examples .....	9-1
connector specifications .....	3-57
Connector Terminal Block Cables .....	2-23, 3-94
Connector Terminal Blocks .....	2-23

Connectors .....	2-20
Connector-Terminal Block Conversion Unit .....	3-96
Connector-Terminal Blocks and Cables .....	4-16
contactors .....	4-39
control cable specifications .....	3-57
Control Cables .....	2-23
Control Gain Switch 1 Setting (Pn31) .....	5-69
Control Gain Switch 2 Setting (Pn36) .....	5-73
control I/O connector specifications .....	3-9
control I/O connectors .....	3-86
control input circuits .....	3-17
control input signals .....	3-12
Control Mode Selection (Pn02) .....	5-53
Control Mode Switch Input (TVSEL) .....	3-13, 3-25
control mode switching .....	5-11
control output circuits .....	3-26
control output sequence .....	3-27
Copy Mode .....	6-24

## D

damping control .....	7-35
Decelerator dimensions .....	2-49
Decelerator installation conditions .....	4-7
Decelerator specifications .....	3-47
Decelerators .....	2-7
Decelerators for 1,000-r/min Servomotors (Backlash = 3' Max.) .....	2-55, 3-52
Decelerators for 2,000-r/min Servomotors (Backlash = 3' Max.) .....	2-53, 3-50
Decelerators for 3,000-r/min Flat Servomotors (Backlash = 15' Max.) .....	2-61, 3-56
Decelerators for 3,000-r/min Flat Servomotors (Backlash = 3' Max.) .....	2-57, 3-53
Decelerators for 3,000-r/min Servomotors (Backlash = 15' Max.) .....	2-59, 3-54
Decelerators for 3,000-r/min Servomotors (Backlash = 3' Max.) .....	2-49, 3-47
Default Display (Pn01) .....	5-52
Deviation Counter Overflow Level (Pn70) .....	5-92
Deviation Counter Reset Condition Setting (Pn4E) .....	5-80
Deviation Counter Reset Input (ECRST) .....	3-13, 3-24
Direction Signal (SIGN) .....	3-12, 3-20, 3-22
disabling adaptive filter .....	7-20
disabling realtime autotuning .....	7-19
disabling the automatic gain adjustment function .....	7-19
Drive Prohibit Input Selection (Pn04) .....	5-54

## E

EC Directives .....	1-10
electronic gear .....	5-16
Electronic Gear Ratio Denominator (Pn4B) .....	5-78
Electronic Gear Ratio Numerator 1 (Pn48) .....	5-78
Electronic Gear Ratio Numerator 2 (Pn49) .....	5-78
Electronic Gear Ratio Numerator Exponent (Pn4A) .....	5-78
Electronic Gear Switch (GESEL) .....	3-13
electronic thermal function .....	8-20
Emergency Stop Torque (Pn6E) .....	5-92
encoder cable noise resistance .....	4-40
Encoder Cables .....	3-57
Encoder Cables (Robot Cables) .....	2-18, 3-60, 4-13
Encoder Cables (Standard Cables) .....	2-14, 3-57, 4-12
encoder connector specifications (CN2) .....	3-30

encoder connectors	3-86
Encoder Divider Denominator Setting (Pn45)	5-76
Encoder Divider Numerator Setting (Pn44)	5-76
encoder dividing	5-15
Encoder Output Direction Switch (Pn46)	5-77
encoder outputs (phases A, B, and Z)	3-28
Encoder Phase-A - Output (-A)	3-15
Encoder Phase-A + Output (+A)	3-15
Encoder Phase-B - Output (-B)	3-15
Encoder Phase-B + Output (+B)	3-15
Encoder Phase-Z - Output (-Z)	3-15
Encoder Phase-Z + Output (+Z)	3-15
encoder specifications	3-46
error diagnosis using the displayed alarm codes	8-6
error diagnosis using the operating status	8-15
error processing	8-1
external dimensions	2-25
External Regeneration Resistor Dimensions	2-63
External Regeneration Resistor specifications	3-130
External Regeneration Resistors	2-23

---

**F**

Feed Pulse (PULS)	3-12, 3-20, 3-22
Feed-forward Amount (Pn15)	5-61
Feed-forward Command Filter (Pn16)	5-61
fit gain function	7-7
Forward Drive Prohibit	5-14
Forward Drive Prohibit Input (POT)	3-12, 3-24
Forward Pulse (CCW)	3-12, 3-20, 3-22
Forward Pulse (CCWLD)	3-14
Forward Torque Limit Input (PCL)	3-12
Frame Ground (FG)	3-15
Front Key Protection Setting (Pn0E)	5-58

---

**G**

gain adjustment	7-1
Gain Switch (GSEL)	3-13
Gain Switch 1 Hysteresis Setting (Pn34)	5-72
Gain Switch 1 Level Setting (Pn33)	5-72
Gain Switch 1 Time (Pn32)	5-71
Gain Switch 2 Hysteresis Setting (Pn39)	5-73
Gain Switch 2 Level Setting (Pn38)	5-73
Gain Switch 2 Time (Pn37)	5-73
gain switching	5-25
gain switching function	7-26
Gain Switching Input Operating Mode Selection (Pn30)	5-68
General-purpose Control Cables	2-23, 3-92, 4-16
General-purpose Output 1 (OUTM1)	3-15
General-purpose Output 1 Selection (Pn0A)	5-57
General-purpose Output 2 (OUTM2)	3-15
General-purpose Output 2 Selection (Pn09)	5-56
General-purpose Output Common (COM)	3-15

---

**H**

harmonic current countermeasures	4-41
----------------------------------	------

---

**I**

IM Selection (Pn08)	5-56
incremental encoders	3-46
Inertia Ratio (Pn20)	5-63

instantaneous speed observer	7-33
Instantaneous Speed Observer Setting (Pn27)	5-65
internally set speed control	5-5
Internally Set Speed Selection 1 (VSEL1)	3-13
Internally Set Speed Selection 2 (VSEL2)	3-13
Internally Set Speed Selection 3 (VSEL3)	3-13

---

**J**

Jog Operation Mode	6-24
Jog Speed (Pn3D)	5-74

---

**L**

leakage breakers	4-33
------------------	------

---

**M**

machine resonance control	7-30
machine rigidity numbers	7-15
main circuit connector	3-6
Main Circuit Connector Specifications (CNA)	3-6, 4-21
Main Circuit Terminal Block Specifications	3-7, 3-8, 4-22, 4-23
manual tuning	7-21
Momentary Hold Time (Pn6D)	5-92
Monitor Mode	6-8
Motion Control Unit Cables	3-89, 4-16
Mounting Brackets (L brackets for rack mounting)	2-24
mounting hole dimensions	2-25

---

**N**

No. 1 Internally Set Speed (Pn53)	5-82
No. 1 Torque Limit (Pn5E)	5-85
No. 2 Internally Set Speed (Pn54)	5-82
No. 2 Torque Limit (Pn5F)	5-85
No. 3 Internally Set Speed (Pn55)	5-82
No. 4 Internally Set Speed (Pn56)	5-82
No. 5 Internally Set Speed (Pn74)	5-82
No. 6 Internally Set Speed (Pn75)	5-82
No. 7 Internally Set Speed (Pn76)	5-82
No. 8 Internally Set Speed (Pn77)	5-82
no-fuse breakers	4-32
noise filters	4-35, 4-36, 4-37, 4-43
noise filters for brake power supply	4-36
noise filters for power supply input	4-35
noise filters for Servomotor output	4-43
Normal mode autotuning	6-20, 7-14
Notch Filter 1 Frequency (Pn1D)	5-62
Notch Filter 1 Width (Pn1E)	5-62
Notch Filter 2 Depth (Pn2A)	5-65
Notch Filter 2 Frequency (Pn28)	5-65
Notch Filter 2 Width (Pn29)	5-65

---

**O**

oil seal	4-5
Operation Switch When Using Absolute Encoder (Pn0B)	5-57
operational procedure	6-1
overload characteristics	8-20
Overload Detection Level Setting (Pn72)	5-93
overrun limit	5-19
Overrun Limit Setting (Pn26)	5-65
Overspeed Detection Level Setting (Pn73)	5-93

# Index

## P

parameter details.....	5-51
Parameter Setting Mode.....	6-17
parameter tables.....	5-33, 9-11
Parameter Unit Connector specifications (CN3B) .....	3-31
Parameter Unit dimensions .....	2-45
Parameter Unit specifications.....	3-129
Parameter Write Mode .....	6-19
periodic maintenance .....	8-21
phase-Z output (open-collector output) .....	3-26
Phase-Z Output (Z).....	3-15
Phase-Z Output Common (ZCOM).....	3-15
pin arrangement .....	3-16
position command filter.....	5-29
Position Command Filter Time Constant Setting (Pn4C) .....	5-79
Position Command Pulse .....	3-17, 3-18
position control .....	5-1
Position Control Mode .....	7-22
Position Control Unit-Servo Relay Unit Cable specifications .....	3-116
position feedback output.....	3-26
Position Loop Gain (Pn10) .....	5-59
Position Loop Gain 2 (Pn18) .....	5-61
Position Loop Gain Switching Time (Pn35) .....	5-72
Positioning Completed Output (INP) .....	3-15, 3-29
Positioning Completion Condition Setting (Pn63).....	5-87
Positioning Completion Range (Pn60) .....	5-86
Power Cables (Robot Cables).....	4-14
Power Cables (Standard Cables).....	4-13
Power cables for Servomotors with brakes (Robot Cables) .....	3-76
power cables for Servomotors with brakes (Standard Cables) .....	3-73
Power cables for Servomotors without brakes (Robot Cables) .....	3-69
power cables for Servomotors without brakes (Standard Cables) .....	3-64
preparing for operation .....	6-2
protective functions.....	3-5
Pulse Prohibit Input (IPG).....	3-13, 3-25

## R

radio noise filters .....	4-37
Reactor dimensions.....	2-64
Reactors .....	2-23, 3-132, 4-41
Realtime Autotuning Machine Rigidity Selection (Pn22).....	5-63
Realtime Autotuning Mode Selection (Pn21).....	5-63
Regeneration Resistor Selection (Pn6C).....	5-92
regenerative energy.....	4-45
regenerative energy (External Regeneration Resistors) .....	4-49
regenerative energy absorption.....	4-48
replacement procedure.....	8-2, 8-23
replacing the Absolute Encoder Battery .....	8-23
replacing the Servo Drive .....	8-2
replacing the Servomotor .....	8-2
Reverse Drive Prohibit.....	5-14
Reverse Drive Prohibit Input (NOT).....	3-12, 3-24
Reverse Pulse (CW).....	3-12

Reverse Pulse (CWLD) .....	3-14
Reverse Torque Limit Input (NCL).....	3-12
Rotation Speed for Motor Rotation Detection (Pn62) .....	5-87
rotational speed characteristics for 1,000-r/min Servomotors .....	3-44
rotational speed characteristics for 2,000-r/min Servomotors .....	3-42
rotational speed characteristics for 3,000-r/min Flat Servomotors .....	3-40
rotational speed characteristics for 3,000-r/min Servomotors .....	3-36
RS-232 Baud Rate Setting (Pn0C).....	5-58
RS-485 Baud Rate Setting (Pn0D).....	5-58
RS-485 communications cables .....	4-15
RUN Command (RUN) .....	3-13, 3-24

## S

S-curve Acceleration/Deceleration Time Settings (Pn5A) .....	5-83
sensor input.....	3-19
Sensor ON Input (SEN) .....	3-12
Sequence Input .....	3-19
Sequence Output.....	3-26
Servo Drive characteristics.....	3-2
Servo Drive dimensions.....	2-25
Servo Drive functions .....	1-4
Servo Drive general specifications .....	3-1
Servo Drive installation conditions.....	4-1
Servo Drive models .....	2-1
Servo Drive part names.....	1-3
Servo Drive service life.....	8-22
Servo Drive-Servo Relay Unit Cables .....	3-112
Servo Drive-Servomotor combinations.....	2-5
Servo Ready Output (READY) .....	3-15, 3-29
Servo Relay Unit Cables for Position Control Units..	2-22
Servo Relay Unit Cables for Servo Drives.....	2-21
Servo Relay Units.....	2-21
Servomotor and Decelerator Combinations .....	2-46
Servomotor characteristics .....	3-33
Servomotor connector specifications (CNB).....	3-6, 4-21
Servomotor general specifications .....	3-32
Servomotor installation conditions.....	4-3
Servomotor models .....	2-2
Servomotor Power Cables (Robot Cables) .....	2-19
Servomotor Power Cables (Standard Cables) .....	2-15
Servomotor Rotation Speed Detection Output (TGON).....	3-15, 3-29
Servomotor service life .....	8-21
setting the mode .....	6-7
Smoothing Filter Setting (Pn4D).....	5-80
soft start.....	5-28
Soft Start Acceleration Time (Pn58) .....	5-83
Soft Start Deceleration Time (Pn59).....	5-83
SP Selection (Pn07) .....	5-55
Speed Command Filter Time Constant (Pn57) .....	5-82
Speed Command Input (REF) .....	3-12, 3-17, 3-24
Speed Command Offset Adjustment (Pn52) .....	5-81
Speed Command Rotation Direction Switch (PNSEL).....	3-13
Speed Command Scale (Pn50).....	5-81
Speed Command/Torque Command Input Overflow Level Setting (Pn71).....	5-93
speed control .....	5-3

---

speed control mode adjustment .....	7-24
Speed Feedback Filter Time Constant (Pn13) .....	5-61
Speed Feedback Filter Time Constant 2 (Pn1B).....	5-62
speed limit .....	5-30
Speed Limit Input (VLIM).....	3-12
speed limit values .....	7-25
Speed Loop Gain (Pn11).....	5-60
Speed Loop Gain 2 (Pn19).....	5-61
Speed Loop Integration Time Constant (Pn12) .....	5-60
Speed Loop Integration Time Constant 2 (Pn1A).....	5-62
Stop Selection for Alarm Generation (Pn68) .....	5-89
Stop Selection for Drive Prohibition Input (Pn66) .....	5-88
Stop Selection with Main Power OFF (Pn67) .....	5-89
Stop Selection with Servo OFF (Pn69).....	5-90
surge absorbers.....	4-34
surge suppressors .....	4-39
Switching the Control Mode.....	5-11
system block diagrams .....	1-5
system configuration.....	1-2

**T**

---

terminal block wire sizes.....	4-24
terminal block wiring .....	4-26
Torque Command Filter Time Constant (Pn14) .....	5-61
Torque Command Filter Time Constant 2 (Pn1C)....	5-62
Torque Command Input (TREF1).....	3-12
Torque Command Input (TREF2).....	3-12
Torque Command Scale (Pn5C) .....	5-84
Torque Command/Speed Limit Selection (Pn5B).....	5-84
torque control.....	5-8
torque control mode adjustment.....	7-25
torque limit .....	5-26
Torque Limit Selection (Pn03) .....	5-53
Torque Limit Switch (TLSEL).....	3-13
Torque Output Direction Switch (Pn5D) .....	5-84
trial operation.....	6-28
troubleshooting .....	8-6

**U**

---

UL and CSA standards.....	1-10
Undervoltage Alarm Selection (Pn65) .....	5-88
Unit No. Setting (Pn00).....	5-51
unit No. switch .....	1-4
user parameters .....	5-31
using the Parameter Unit.....	6-6

**V**

---

Vibration Filter 1 Setting (Pn2C).....	5-66
Vibration Filter 2 Setting (Pn2E) .....	5-66
Vibration Filter Selection (Pn24) .....	5-64
Vibration Filter Switch (DFSEL).....	3-13
Vibration Frequency 1 (Pn2B) .....	5-65
Vibration Frequency 2 (Pn2D) .....	5-66

**W**

---

wire sizes.....	4-25
wiring conforming to EMC Directives.....	4-27

**Z**

---

Zero Speed Designation Input (VZERO) .....	3-13
--	------

Zero Speed Designation/Speed Command Direction Switch (Pn06) .....	5-55
Zero Speed Detection (Pn61).....	5-86

---

## Revision History

A manual revision code appears as a suffix to the catalog number on the front and back covers of the manual.

Cat. No. I562-E1-04

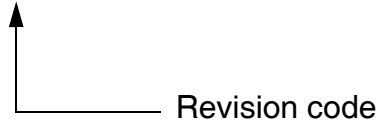

The following table outlines the changes made to the manual during each revision. Page numbers refer to the previous version.

Revision code	Date	Revised content and pages
01	February 2008	Original production
02	July 2008	Changes were made throughout the manual to add information, and make minor corrections.
03	October 2009	Changes were made throughout the manual to add information, and make minor corrections.
04	January 2017	Changes were made throughout the manual to add information, and make minor corrections.



**OMRON Corporation Industrial Automation Company**  
Kyoto, JAPAN

Contact: [www.ia.omron.com](http://www.ia.omron.com)

**Regional Headquarters**

**OMRON EUROPE B.V.**

Wegalaan 67-69, 2132 JD Hoofddorp  
The Netherlands  
Tel: (31)2356-81-300/Fax: (31)2356-81-388

**OMRON ELECTRONICS LLC**

2895 Greenspoint Parkway, Suite 200  
Hoffman Estates, IL 60169 U.S.A.  
Tel: (1) 847-843-7900/Fax: (1) 847-843-7787

**OMRON ASIA PACIFIC PTE. LTD.**

No. 438A Alexandra Road # 05-05/08 (Lobby 2),  
Alexandra Technopark,  
Singapore 119967  
Tel: (65) 6835-3011/Fax: (65) 6835-2711

**OMRON (CHINA) CO., LTD.**

Room 2211, Bank of China Tower,  
200 Yin Cheng Zhong Road,  
PuDong New Area, Shanghai, 200120, China  
Tel: (86) 21-5037-2222/Fax: (86) 21-5037-2200

**Authorized Distributor:**

© OMRON Corporation 2008-2017 All Rights Reserved.  
In the interest of product improvement,  
specifications are subject to change without notice.

**Cat. No. I562-E1-04**

0117