



Elevator Commissioning Guide

- 1 Power Check
- 2 Elevator Commissioning Process Guide
- 3 Single Elevator Commissioning
- 4 Summary of Parameters
- 5 Product Dimensions
- 6 Error Codes

This chapter provides the operation instructions for the elevator industry. Refer to the content of this chapter, you can quickly complete the installation and commissioning of elevators, including related wiring and parameter setting.

Please pay special attention to the following precautions while operating this product.

 <p>DANGER</p>	<ul style="list-style-type: none"> ☑ Be sure to turn off the power before wiring. ☑ When the product is energized, do not remove the cover so as to avoid the risk of electric shock. ☑ Terminal E[⊕] must be properly grounded. The 230V series shall be grounded with Type 3 grounding; the 460V series shall be grounded with the special grounding.
 <p>CAUTION</p>	<ul style="list-style-type: none"> ☑ Before starting the operation, please make sure the compatibility between Delta's Integrated Elevator Drive (IED) and the motor of the elevator; please refer to Appendix A Specifications. ☑ When a Delta IED is in operation, do not touch the heat sink (socket) and the braking resistor to avoid the risk of burns. ☑ During the installation, the installation precautions must be observed; unauthorized operating environment may result in fire, gas explosion, electrical induction and other events. ☑ If the wiring between the Delta IED and a motor is too long, the interlayer insulation of the motor may be damaged. In this case, please replace the motor with an AC motor dedicated for Delta IED or install a reactor (Please refer to Appendix B) between Delta IED and the AC motor so as to prevent the damaged insulation from burning the AC motor. ☑ The rated voltage of the power system for installing the Delta IED shall not exceed 240 V for the 230 series (480V for the 460 series); and the current shall not exceed 5000A RMS (10000A RMS for the models with capacities higher than 40HP (30kW))

1 Power Check

Checks before Power is Supplied

After the control system's wiring is complete, it is necessary to check the wiring:

1. Check if the electrical parts and mechanical parts are connected properly so as to ensure safety.
2. Please refer to the Operation Manual and Wiring Instructions to check if all the connections are correct. While executing the commissioning, it is recommended to execute the operation by two or more operators; if any error occurs, shut off the power immediately.
3. Check if the part numbers of devices match the requirements. The safety circuit is connected properly and the signal is normal. The door lock circuit is connected properly and the signal is normal.
4. The hoistway is clear and there is no person in the elevator car; the condition is ready for safe operation of the elevator.
5. Be sure to check if the power to be supplied and the electrical wiring are correct. Be sure to avoid damaging Delta IED due to supplying incorrect power.
6. Please check if the control cabinet, motor chassis, elevator car's ground wire, and hall door's ground wire are grounded safely so as to ensure personal safety. (Note: The control box and the motor chassis shall be one-point grounded.)
7. Short-circuit checks for the control cabinet to the ground: if any short circuit is found for the following items (a) ~ (e), please solve the problem before supplying power to the device.
 - (a) Three phase wires of the input power cord to the ground;
 - (b) Three phase wires of the motor to the ground;
 - (c) Communication lines to the ground;
 - (d) The encoder wire to the ground.
8. Please make sure that the following items are grounded reliably:
 - (a) The control cabinet should be grounded;
 - (b) The motor should be grounded;
 - (c) The elevator car's ground wire should be grounded;
 - (d) The door motor should be grounded;
 - (e) The pipelines should be grounded;
 - (f) The encoder's shield at the control cabinet should be grounded;
 - (g) The encoder's shield at the motor end should be grounded.(Note: For asynchronous motor: the encoder's shield should be grounded at one end. For synchronous motor: the encoder's shield should be grounded at both ends.)
9. Wiring checks for the communication wires, encoder wires and power cord:
 - (a) The communication cable for the hoistway should be twisted pair with a twist pitch < 35 mm;
 - (b) The communication cable for the elevator car should be twisted pair with a twist pitch < 35 mm;
 - (c) The communication cable for parallel/group control should be twisted pair with a twist pitch < 35 mm; (for group control only)
 - (d) The encoder cable and power cord should be wired in separate pipelines;

(e) The communication cable and the power cord should be wired in separate pipelines;

(f) The communication cable for parallel/group control and the power cord should be wired in separate pipeline (for group controlled elevators only).

List of Wiring Products

Car-Top Signal Terminal Board

EA-CT01

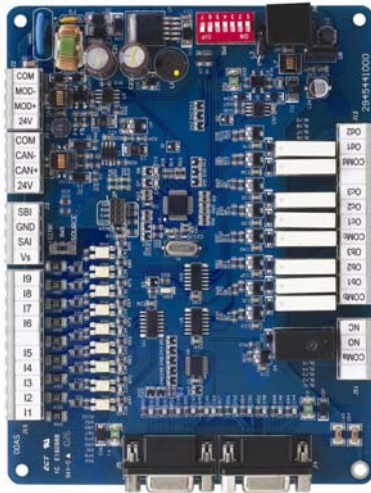

Dimensions

Unit: mm [inch.]

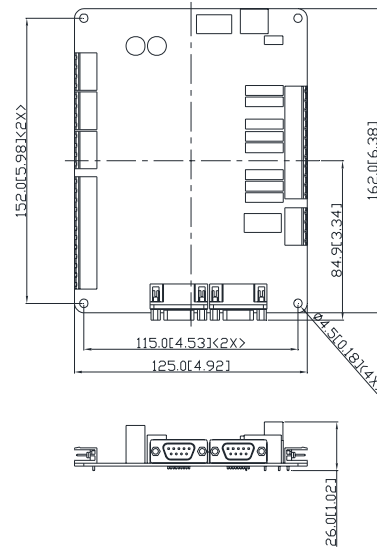

Terminals	Description
I1~I9	Multi-function input terminals ; front/rear door open-/close limit signals; front/rear door open-/close-position attained signals; front/rear door light curtain signal
SAI/SBI/GND/Vs	Analog input terminals for the connection of weighing signal input
CAN+ / CAN-	CAN communication
MOD+ / MOD-	Modbus communication
J4, J5	Connect car command board
Ob1~Ob3-COMb Oc1~Oc3-COMc Od1~Od2-COMd NO-COMa/ NC-COMa	Multi-function relay outputs; door open/close signals; up-/down- position attained signal; elevator car fan/lighting control;

Elevator Car Command Board

EA-CP16



Dimensions

Unit: mm [inch.]

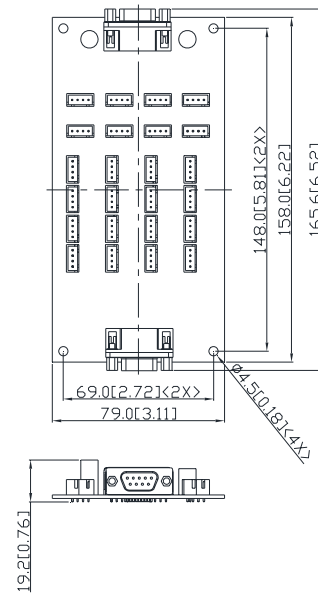

Terminals	Description
CN1	Connection to the car-top board, integrated car-top board, car display board
CN2	Extension slot for connection to another EA-CP16 (More than 16 floors applications)
JP1 ~ JP16	Elevator car's floor button plug-in
JP17 - JP24	Door open/close outputs; door open delay output; non-stop output; operator control output; independent operation output; fireman output, etc.

Integrated Elevator Car Command Board

EA-CTP01



Dimensions

Unit: mm [inch.]

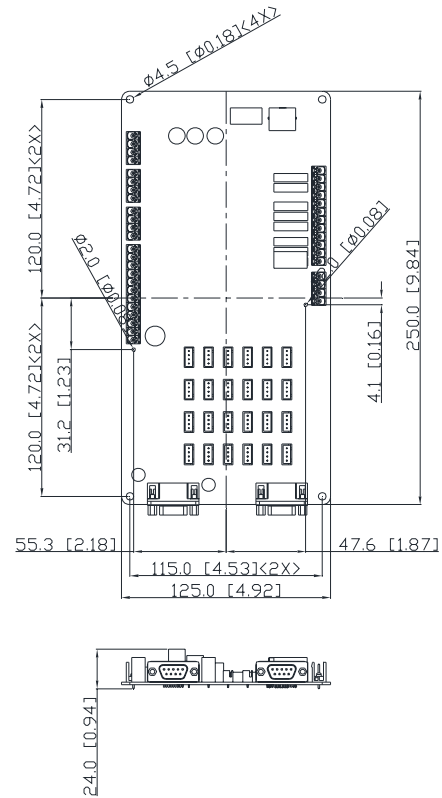

Terminals	Description
I1 ~ I9	Multi-function input terminals Front/rear door open-/close- position attained signals; front/rear door light curtain signal;
SAI/SBI GND/Vs	Analog input terminals for the connection of weighing signal input
CAN+ / CAN- MOD+ / MOD-	CAN communication Modbus communication
CN1	Extension slot for connection to the car command board (primary) (More than 16 floors applications)
CN2	Extension slot for connection to the car command board (secondary) (More than 16 floors applications)
JP1 ~ JP16	Elevator car's floor button plug-in
JP17 ~ JP24	Door open/close outputs; door open delay output; non-stop output; attendant operation output; independent operation output; fireman output, etc.
Ob1~Ob3-COMb Oc1~Oc3-COMc Od1~Od2-COMd NO-COMa/ NC-COMa	Multi-function relay outputs Door open/close signals; Up-/down-to-position signals; Elevator car fan/light control;

Vertical/Horizontal Matrix Display Board

EA-FM02MH

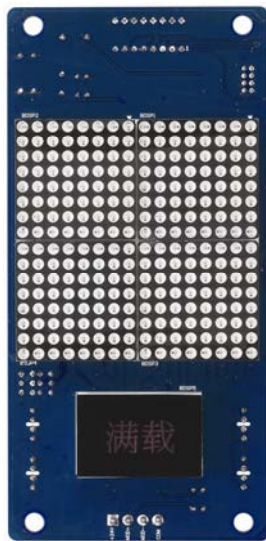

Dimensions

Unit: mm [inch.]

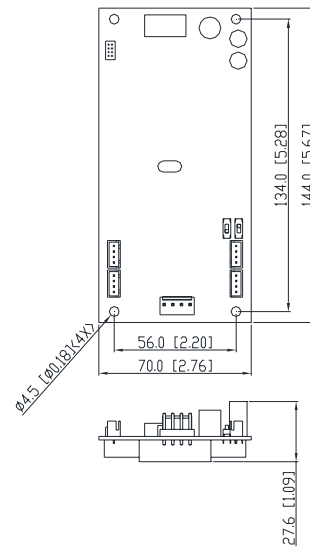

Terminals	Description
J1	Modbus communication and power cord terminals, 4-pin interface: Pin 2 and Pin 3 are Modbus communication cable wires; Pin 1 and Pin 4 are for power wiring.
J2, J3	Up/Down call button interface: Pin 2 and Pin 3 are wires for digital input wiring; Pin 1 and Pin 4 are used for button indicator output signal control
J4	For up-/down-position attained indicator output signal control
J5	Fire/Lock button interface: Pin 1 and Pin 4 are used for Fire button input; Pin 2 and Pin 3 are used for Lock button input

Vertical Display Board

EA-FM02MV

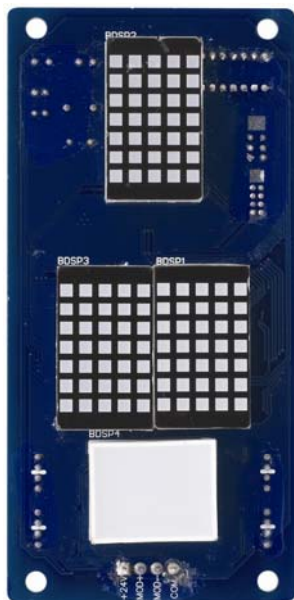

Dimensions

Unit: mm [inch.]

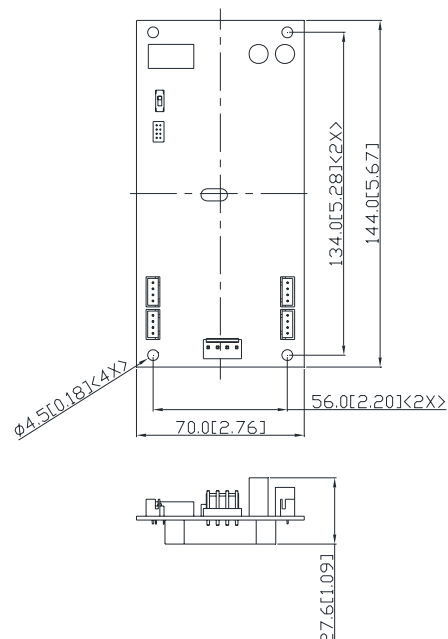

Terminals	Description
J1	Modbus communication and power cord terminals, 4-pin interface: Pin 2 and Pin 3 are Modbus communication cable wires; Pin 1 and Pin 4 are for power wiring.
J2, J3	Up/Down call button interface: Pin 2 and Pin 3 are wires for digital input wiring; Pin 1 and Pin 4 are used for button indicator output signal control
J4	Fire button interface: Pin 2 and Pin 3 are wires for number of input switches; Pin 1 and Pin 4 are used for button indicator output signal control
J5	Lock button interface: Pin 2 and Pin 3 are wires for number of input switches; Pin 1 and Pin 4 are used for button indicator output signal control

Digital Input Card
EMED-D411A110V

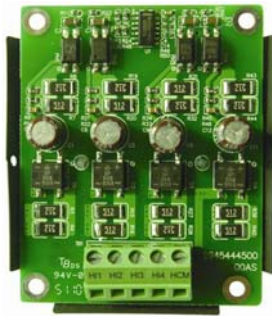

※ This digital input card is supplied with 110Vac.

Terminals	Description
HCM	AC power common node for digital Multi-function input terminals
HI1 ~ HI4	Input Voltage: 100VAC ~ 130VAC Input frequency: 47 ~ 63 Hz

PG Feedback Card
EMED-PGAB

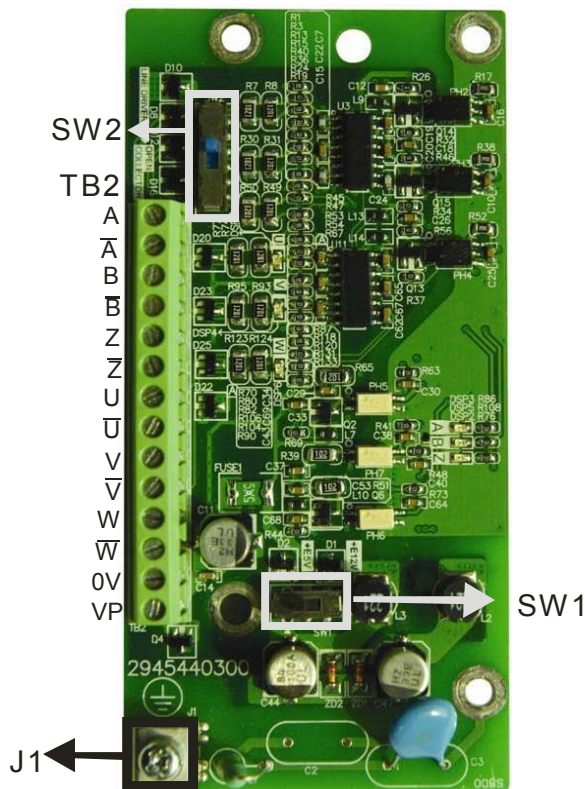

Dimensions

Unit: mm [inch.]

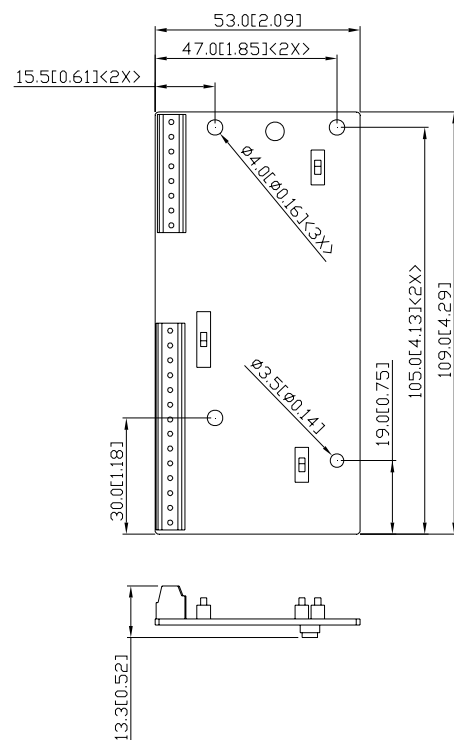





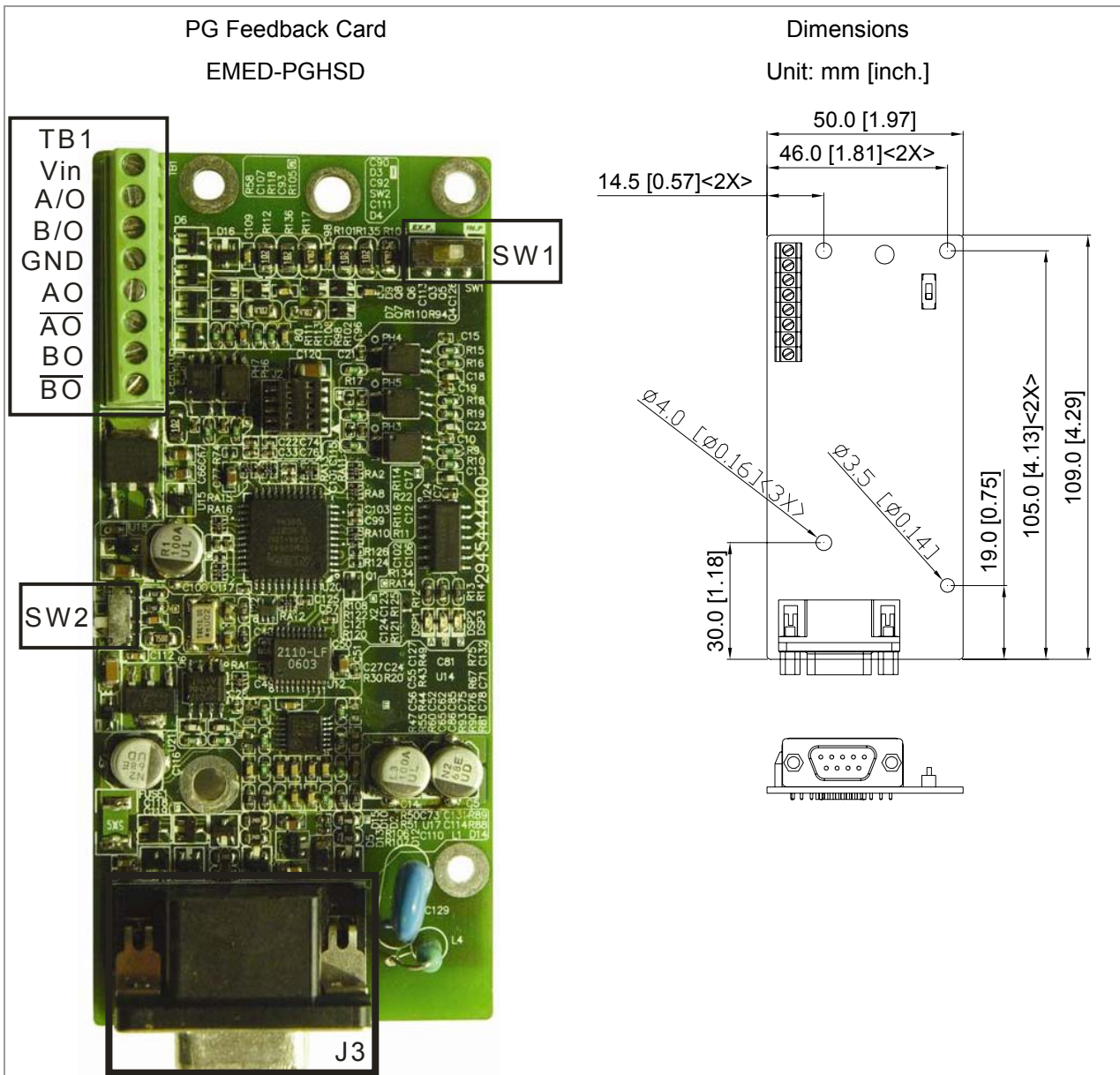



※ The open-collector, Line Driver, and U V W encoder signal are supported.

Terminals	Description
TB1	VP Encoder power output Output voltage: +5V/+12V (+5V/+12V is determined by SW1), Maximum output current: 200mA
	0V Common node for encoder power
A, /A, B, /B, Z, /Z	Encoder signal input Line Driver input complies with RS422 standard Single-ended input specifications: to receive a +12 V open collector signal (which is determined by SW2) Maximum input frequency: 100kHz
U, /U, V, /V, W, /W	Encoder differential absolute signal input Maximum input frequency: 50kHz
SW1	Encoder 5V/12V switch
SW2	Input open collector/Line Driver switch



※ Heidenhain ERN1387, EnDat2.1, and HIPERFACE are supported.

Terminals		Description
TB1	Vin	Input voltage (the voltage amplitude for adjusting the push-pull pulse output) Maximum input voltage: 24VDC
	GND	Common node for input power/output signals
	A/O, B/O	Push-pull pulse output signal Maximum output current: 20mA Maximum output frequency: 100kHz
	AO, /AO, BO, /BO	Differential pulse output signal Maximum output current: 50mA Maximum output frequency: 100kHz
D-SUB 9 Connector (J3)		Encoder signal input Heidenhain ERN1387 Encoder is supported Heidenhain EnDat2.1 SICK HIPERFACE
SW1		To switch between IN.P and EX.P
SW2		Encoder 5V/12V switch

Digital Operation Panel <i>KPED-CE01</i>	
	
Buttons	Description
	Status Display UP: Upward movement DN: Downward movement D1: Safety signal D2: Upper leveling signal D3: Door lock signal D4: Lower leveling signal
	Horizontal movement buttons: For moving the cursor position for value adjustment
	Reset button for recovery from errors
 	Value adjustment button: For modifying the settings and parameters
	Screen selection button: For successively change the displayed items for choice
	Parameter data setting button: For reading or modifying various parameter settings

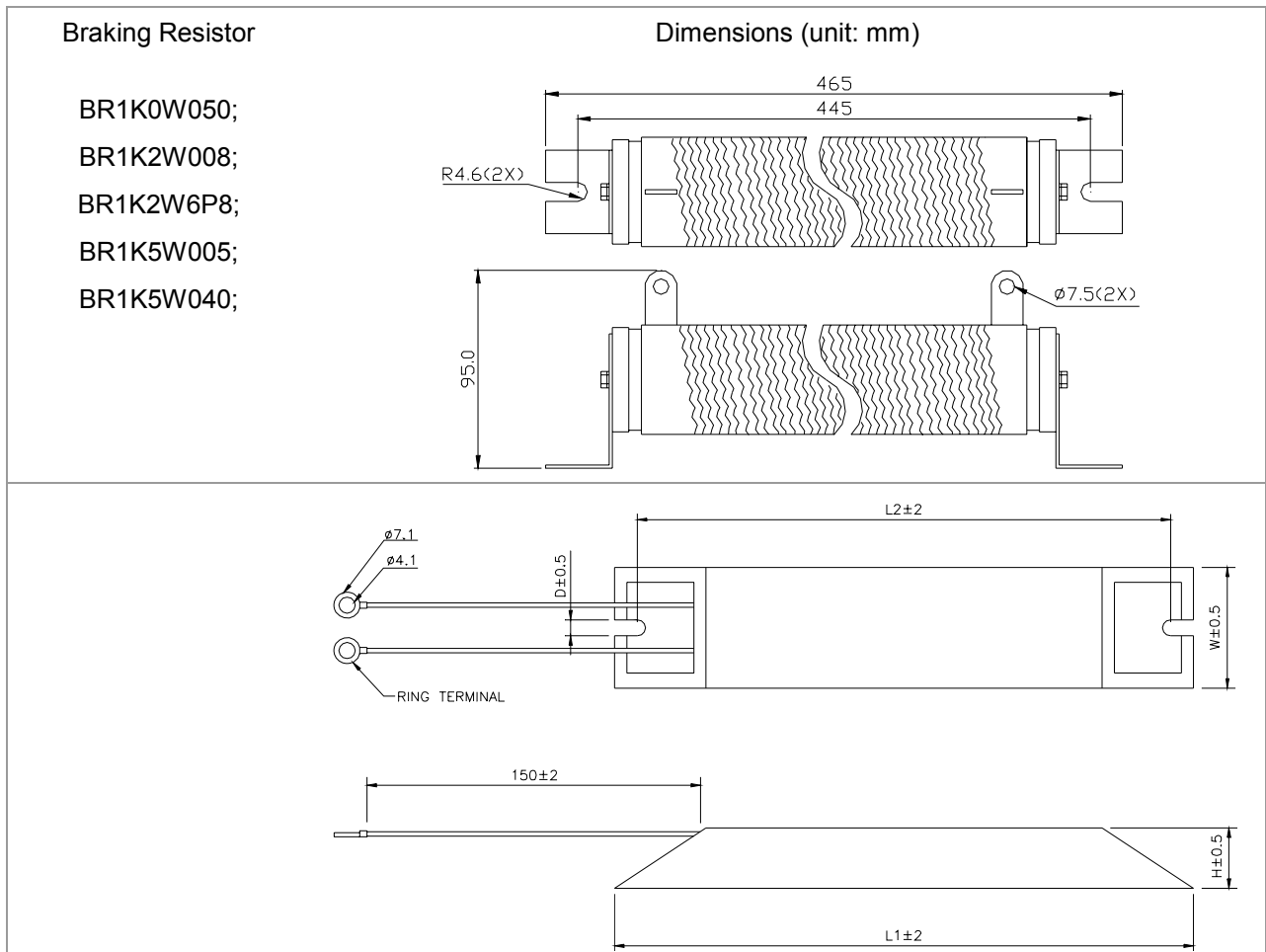

TYPE	L1	L2	H	D	W	MAX. WEIGHT (g)
BR080W200	140	125	20	5.3	60	160
BR080W750	140	125	20	5.3	60	160
BR300W070	215	200	30	5.3	60	750
BR300W100	215	200	30	5.3	60	750
BR300W250	215	200	30	5.3	60	750
BR300W400	215	200	30	5.3	60	750
BR400W150	265	250	30	5.3	60	930
BR400W040	265	250	30	5.3	60	930

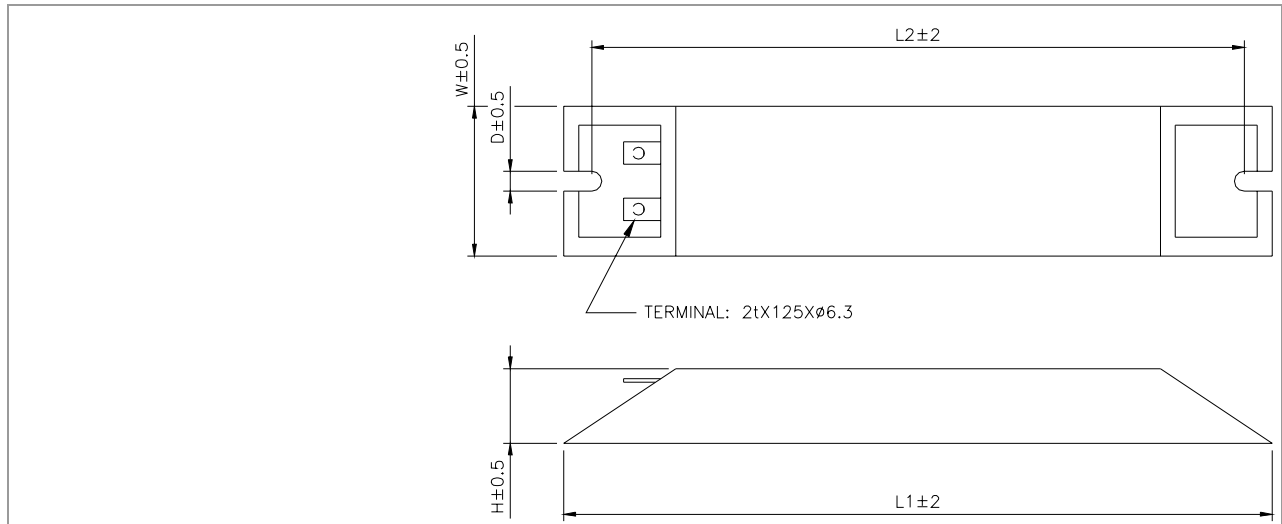

TYPE	L1	L2	H	D	W	MAX. WEIGHT (g)
BR500W030	335	320	30	5.3	60	1100
BR500W100	335	320	30	5.3	60	1100
BR1K0W020	400	385	50	5.3	100	2800
BR1K0W075	400	385	50	5.3	100	2800

2 Elevator Commissioning Process Guide

Elevator Commissioning Process

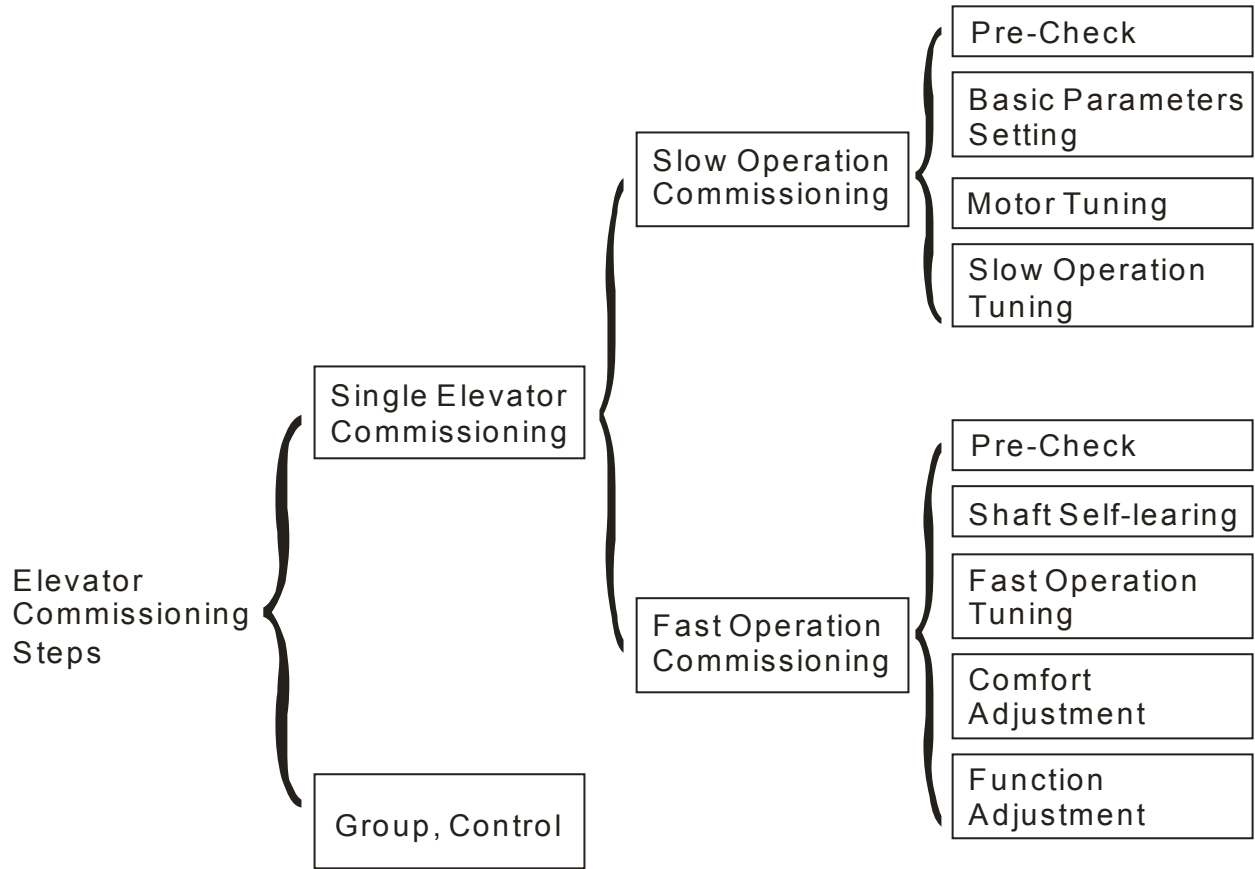

Figure D1-1

Flow chart of basic parameter commissioning for slow car movement

Elevator Basic/ Others Parameter Settings

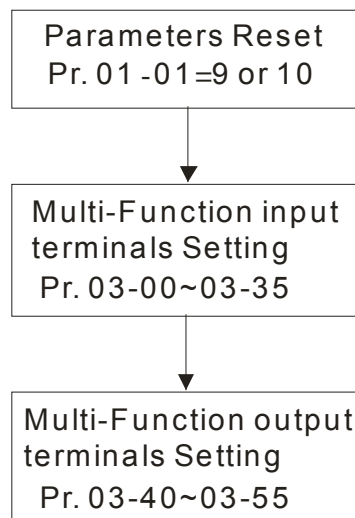

Figure D1-2

Flow chart for motor tuning

Induction motor tuning

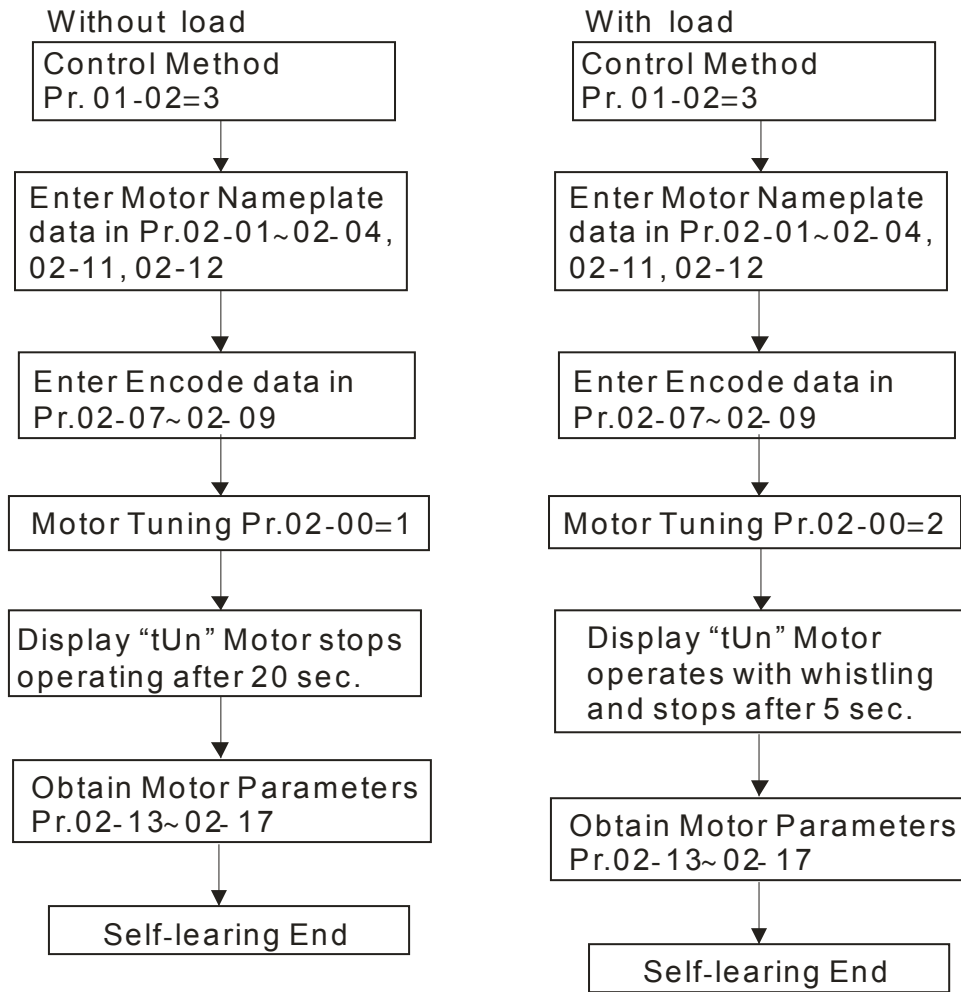

Figure D1-3

Synchronous motor tuning

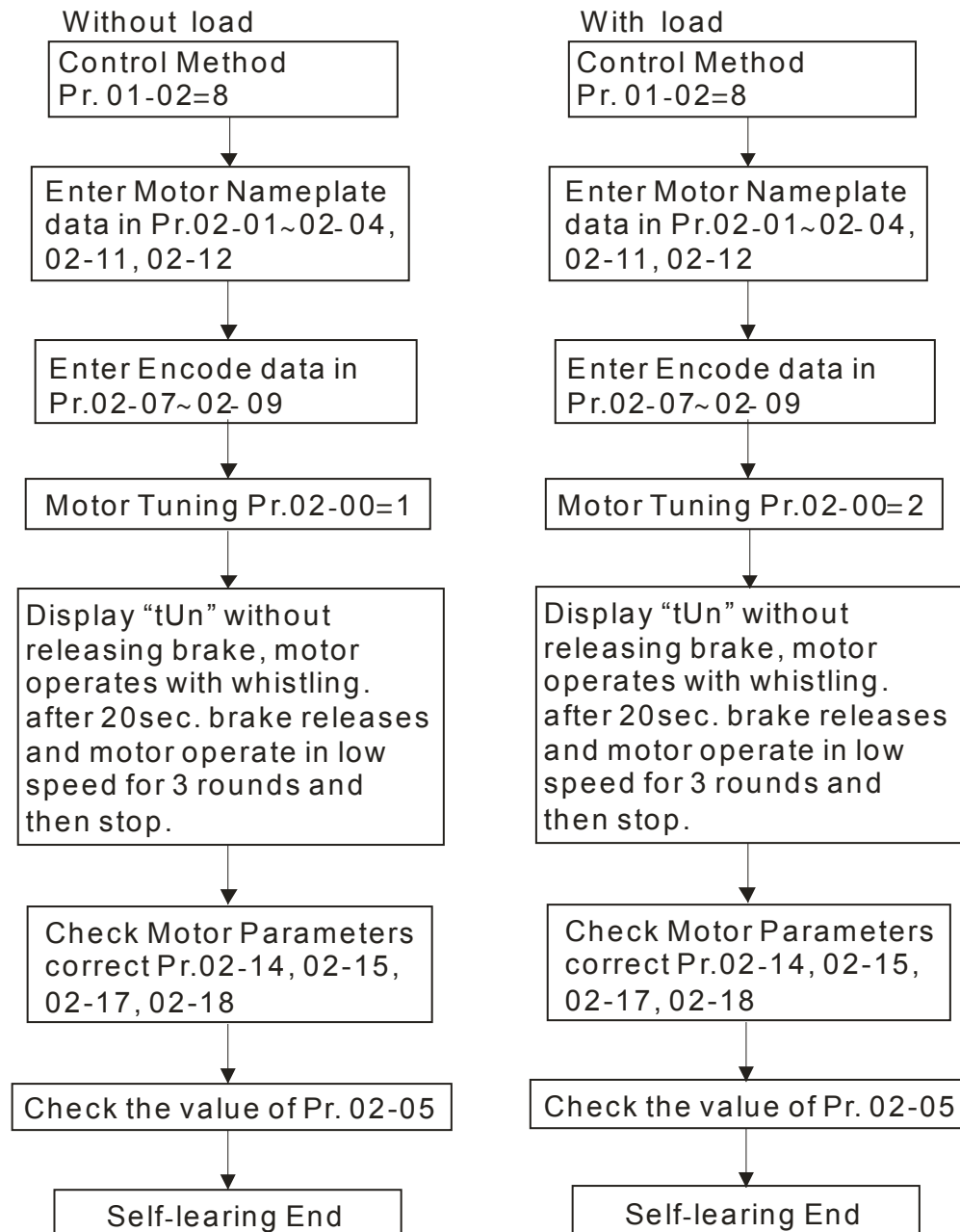

Figure D1-4

Commissioning flow chart for fast car movement

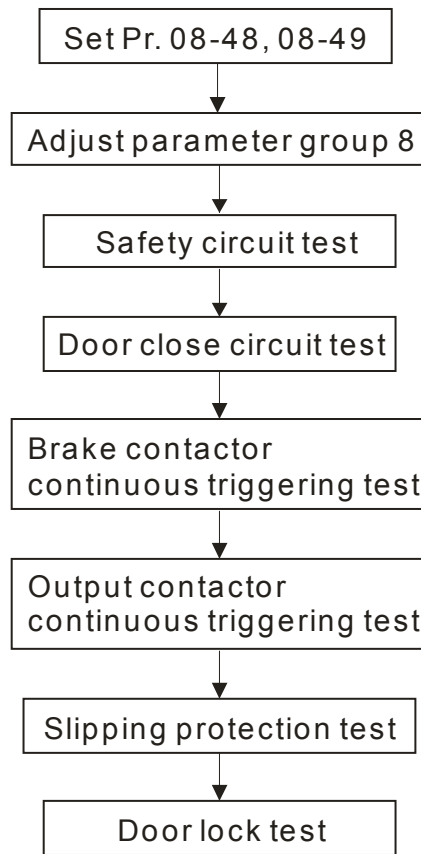

Figure D1-5

Wiring diagram

Overall wiring

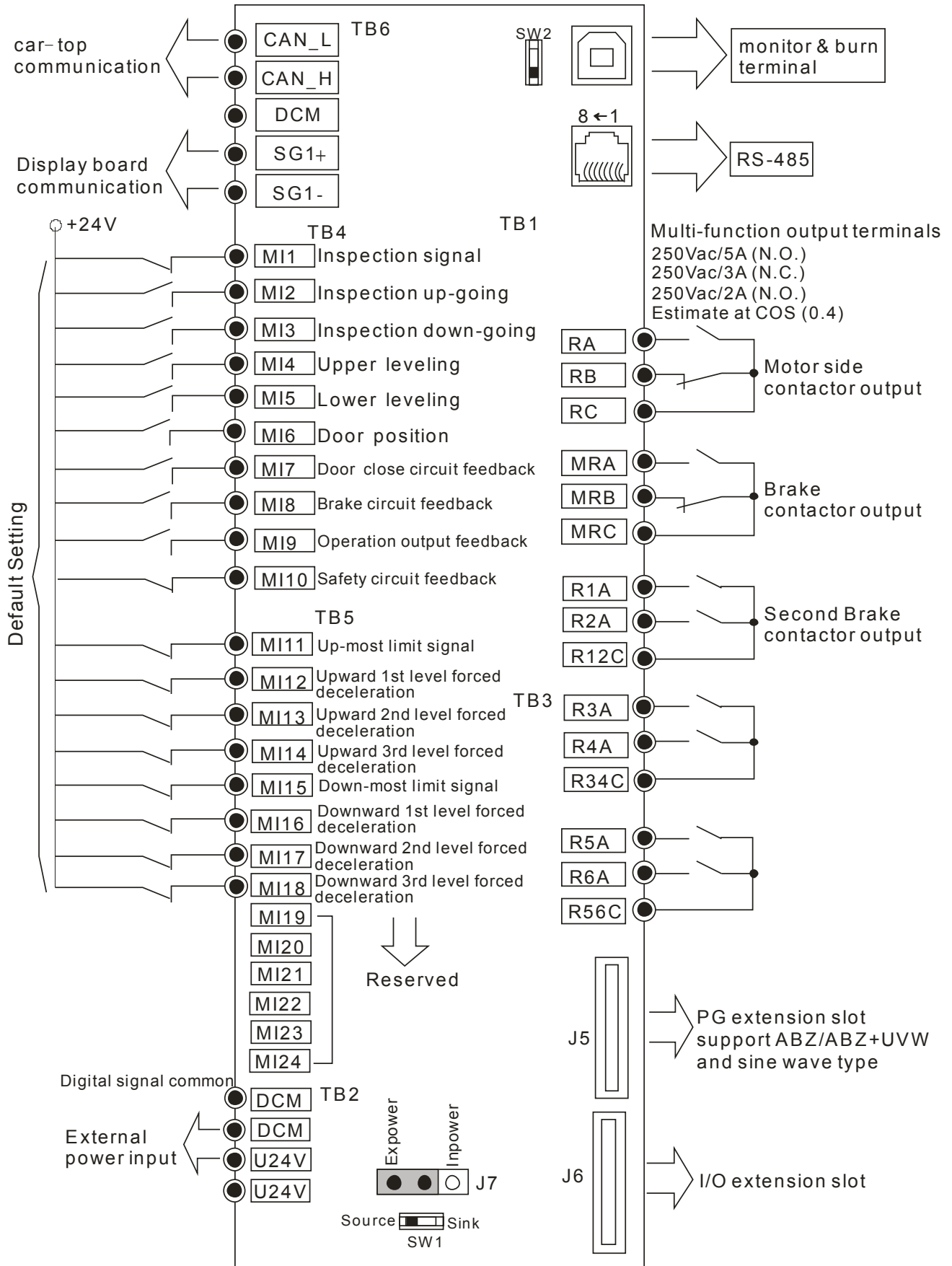
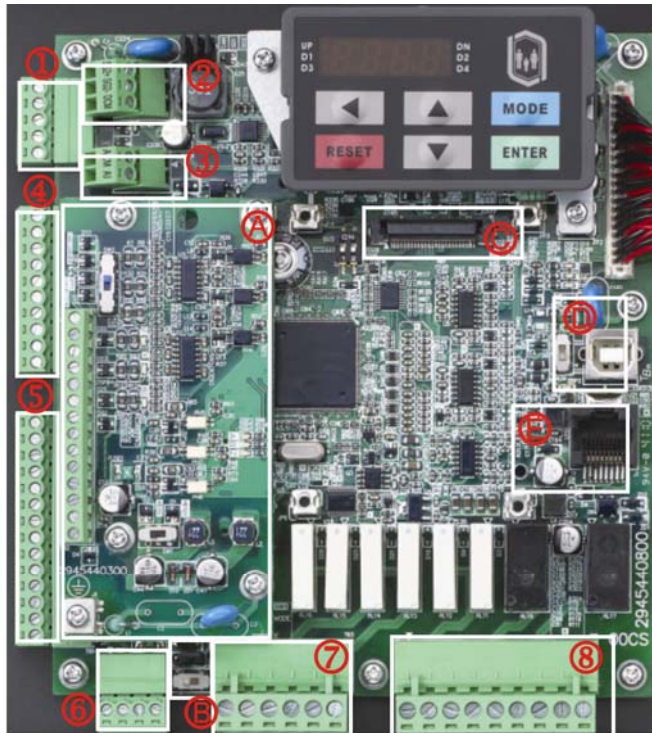

Figure D1-6

Control board layout 1



A PG feedback (J6)
EMED-PGAB EMED-PGHSD



B MI power source Jumper (J7)
Switch (SW1) Sink/Source

C I/O extension slot (J5)
EMED-D411A



- 1** Serial communication (TB6)
Connect to CANBUS of car-top board /MODBUS of display board. Please refer to figure D1-8.
- 2** MODBUS communication (for group control) (TB7)
- 3** Analog input (TB8)
- 4** MI1~MI10 input terminal (functions can be set) (TB4)
- 5** MI11~MI24 input terminal (functions can be set)(TB5)
- 6** 24V power supply input (TB2)
- 7** Relay output terminal (functions can be set)(R3A/R4A/ R34C/R5A/R6A/R56C) (TB3)
- 8** Relay output terminal (functions can be set)(RA/RB/ RC/MRA/MRB/MRC/R1A/R2A/R12C) (TB1)
- D** Programming port / Hoist controller monitoring port
- E** keypad port (RJ45)

Figure D1-7

① Serial Communication (TB6)
 Connect to CANBUS of car-top board/MODBUS of display board

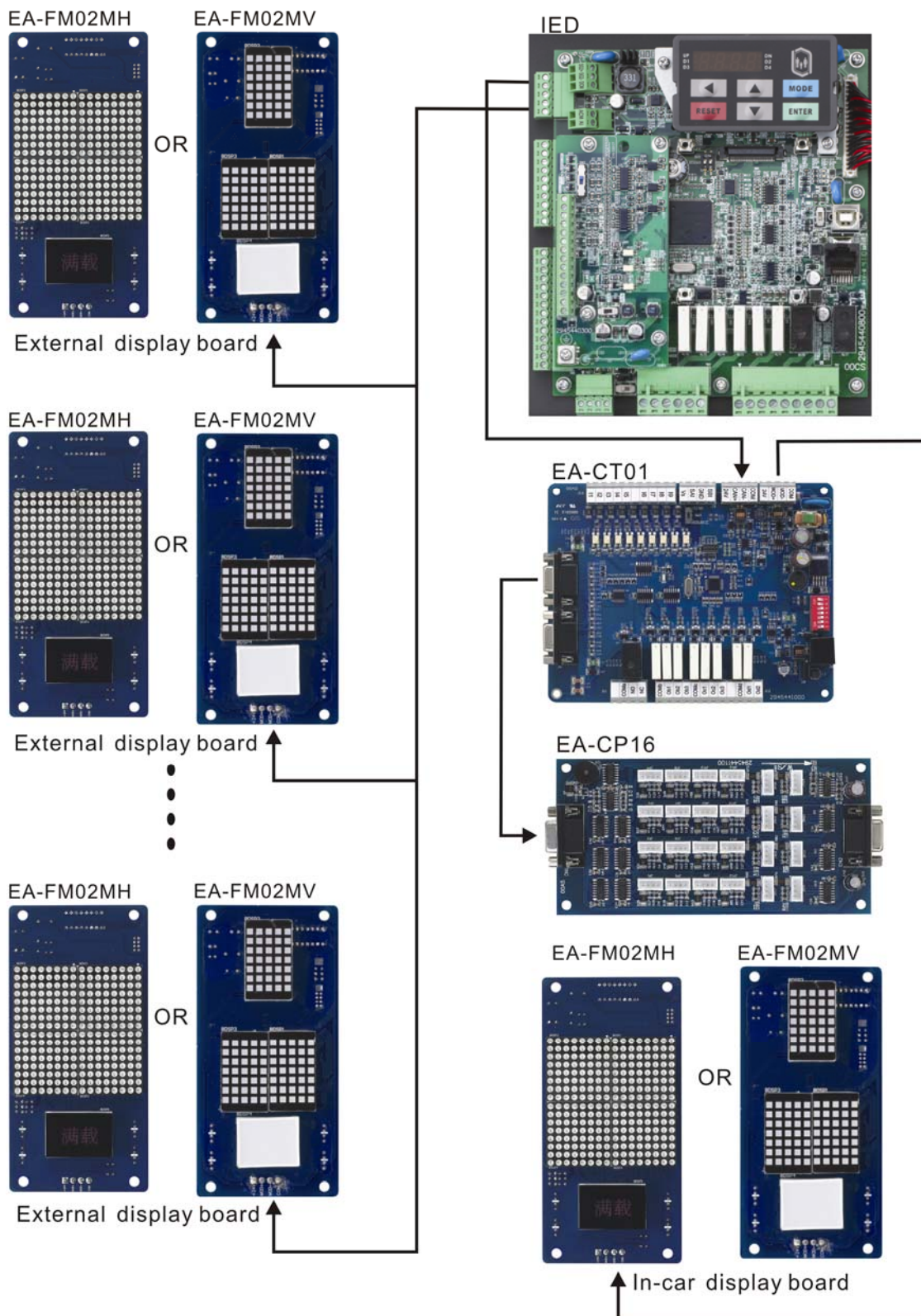

Figure D1-8-1

① Serial Communication (TB6)
Connect to CANBUS of car-top board/MODBUS of display board

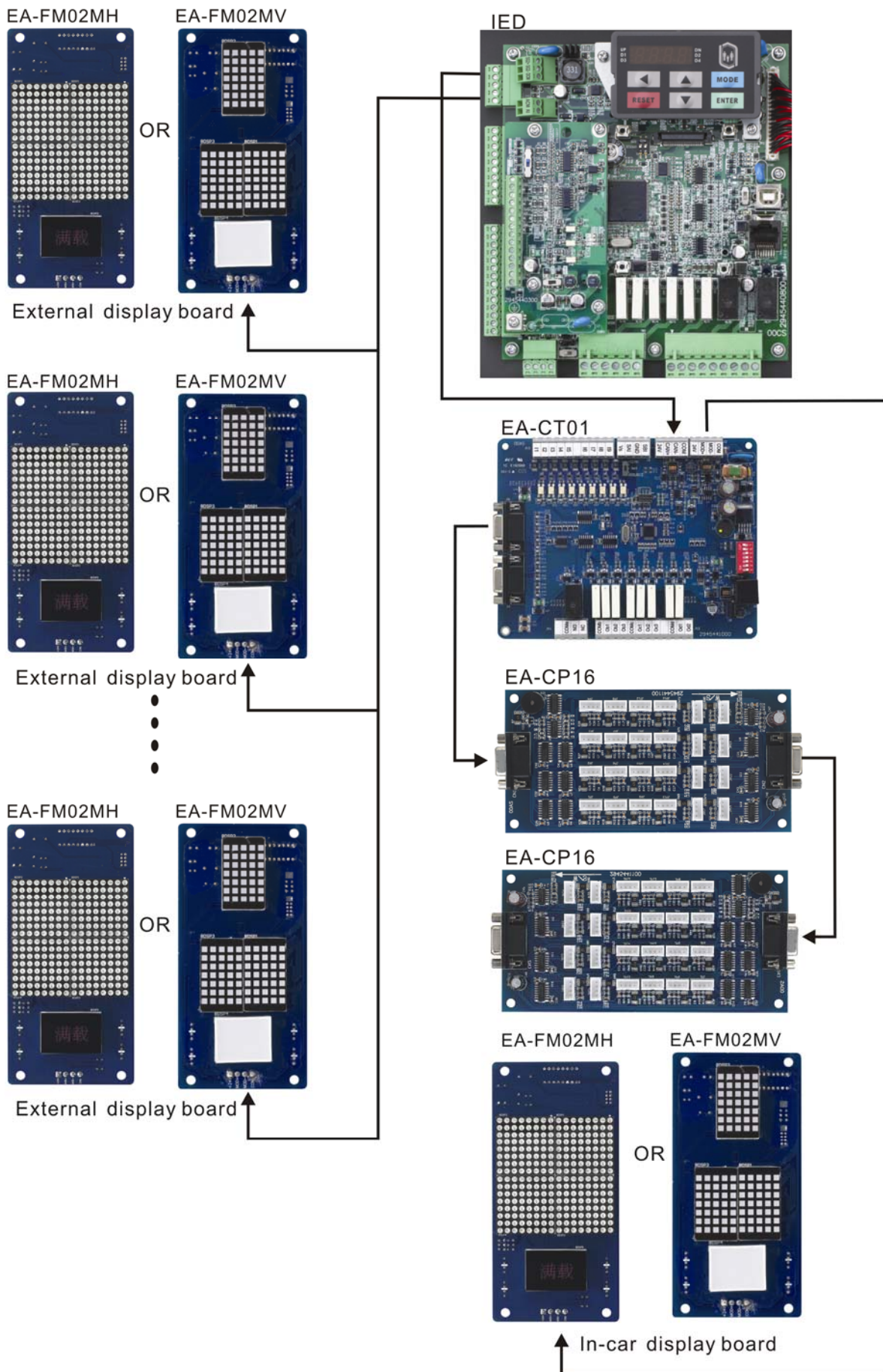

Figure D1-8-2

① Serial Communication (TB6)
Connect to CANBUS of car-top board/MODBUS of display board

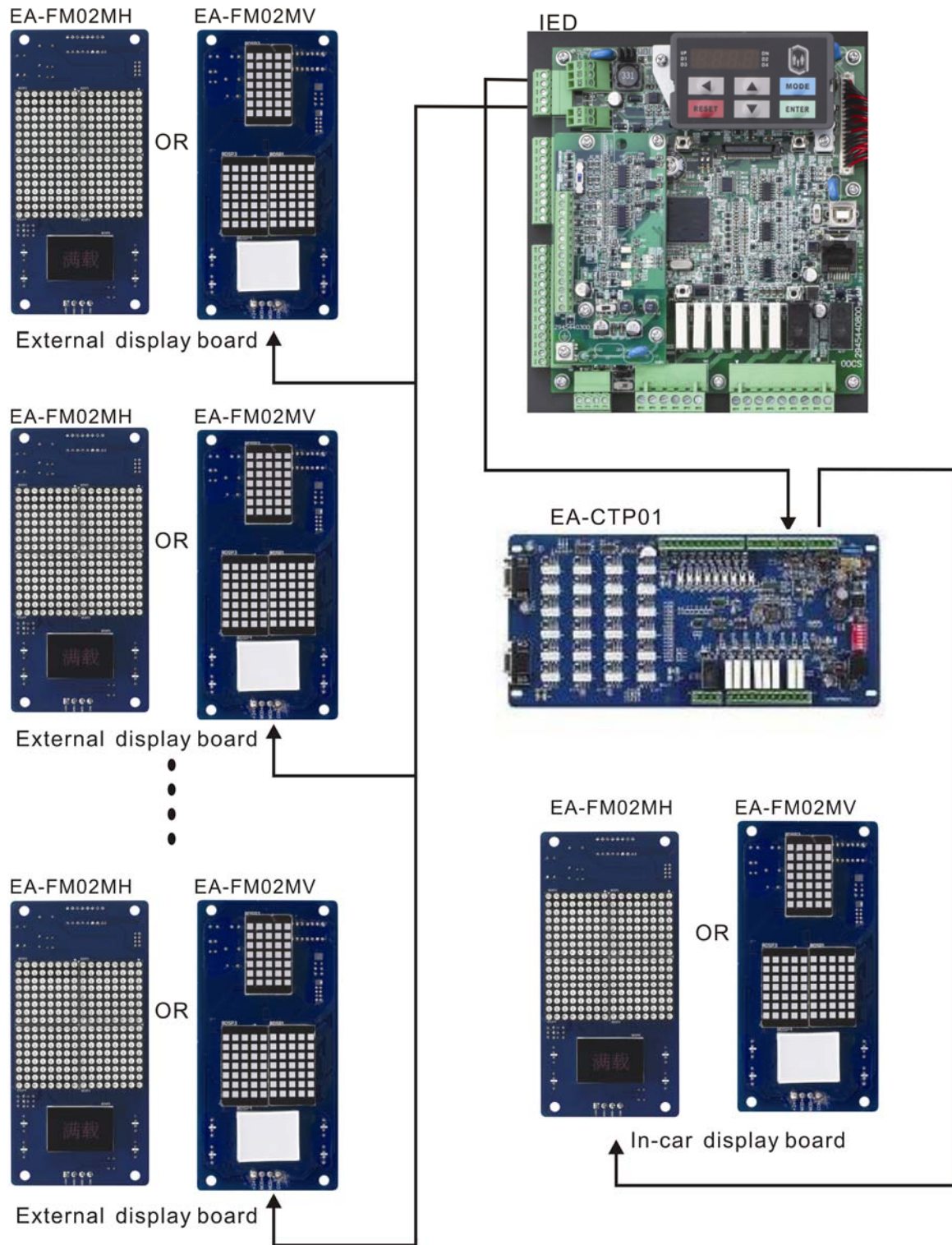

Figure D1-8-3

Control board layout 2

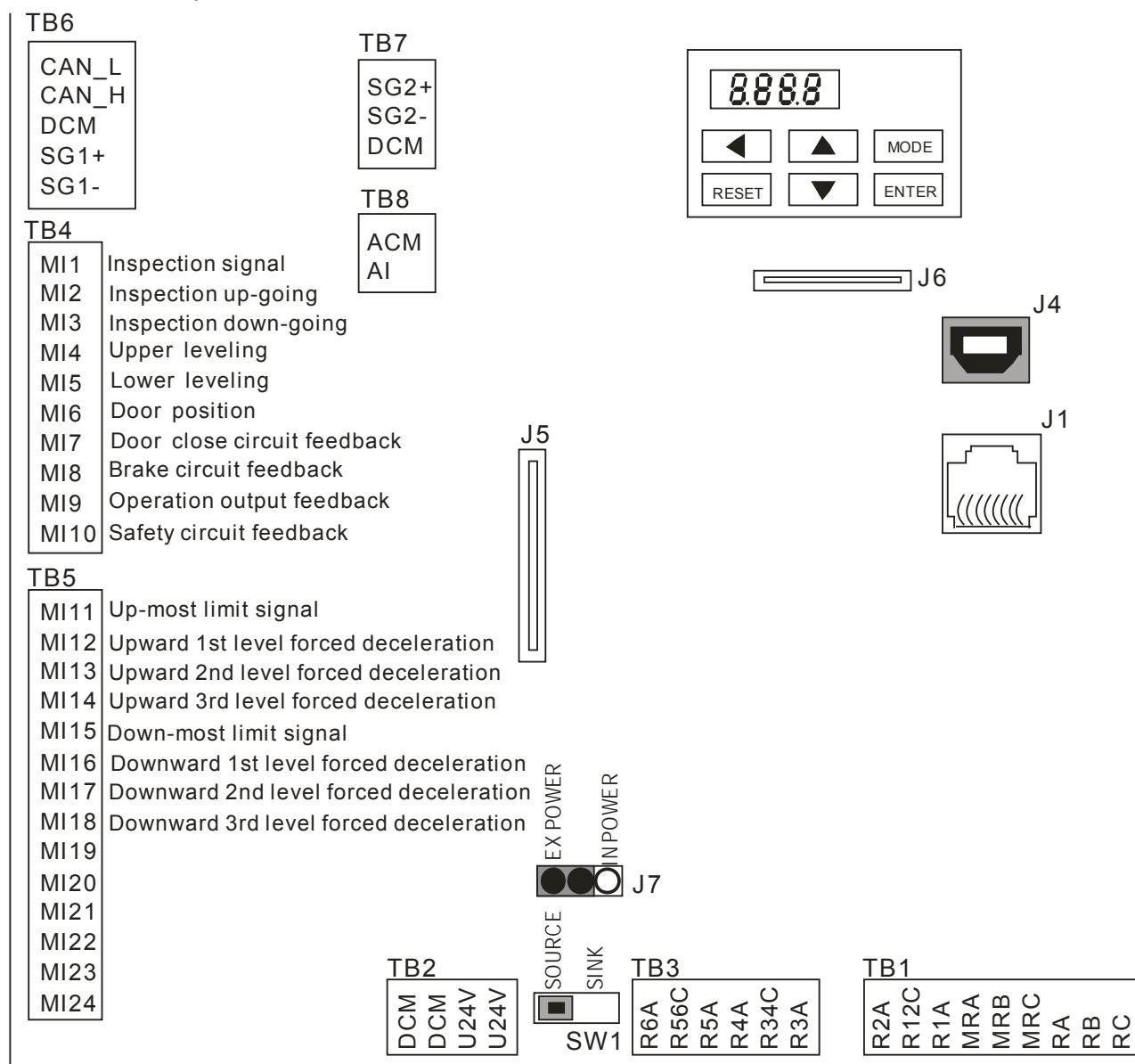

Figure D1-9

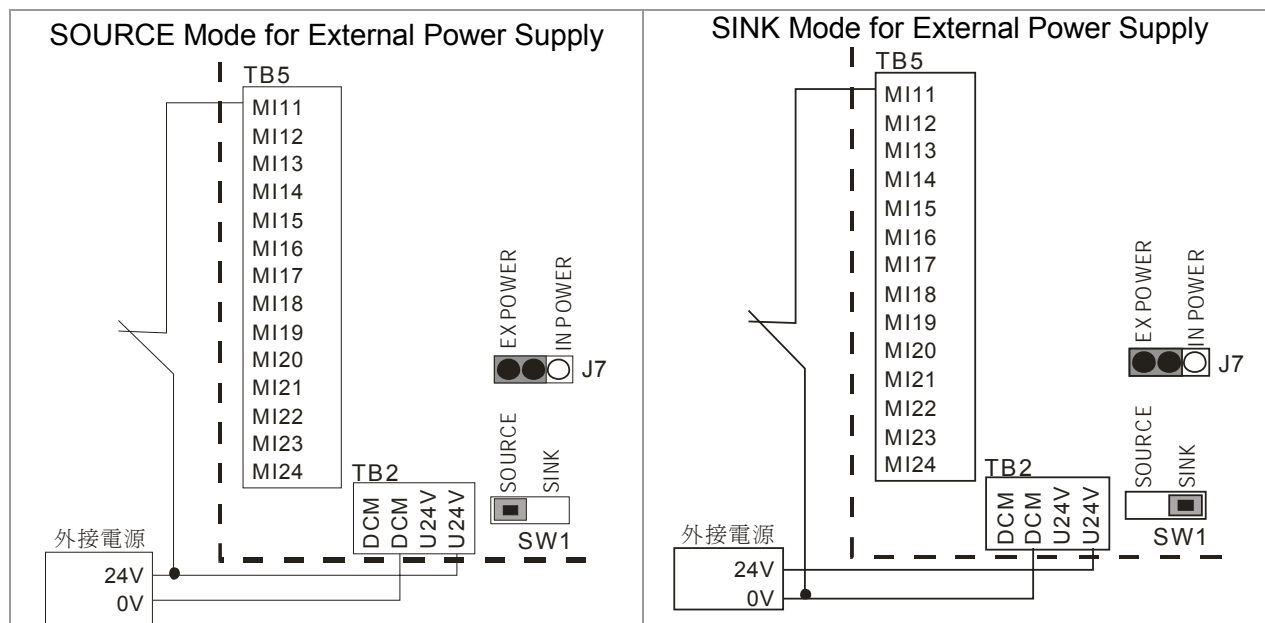
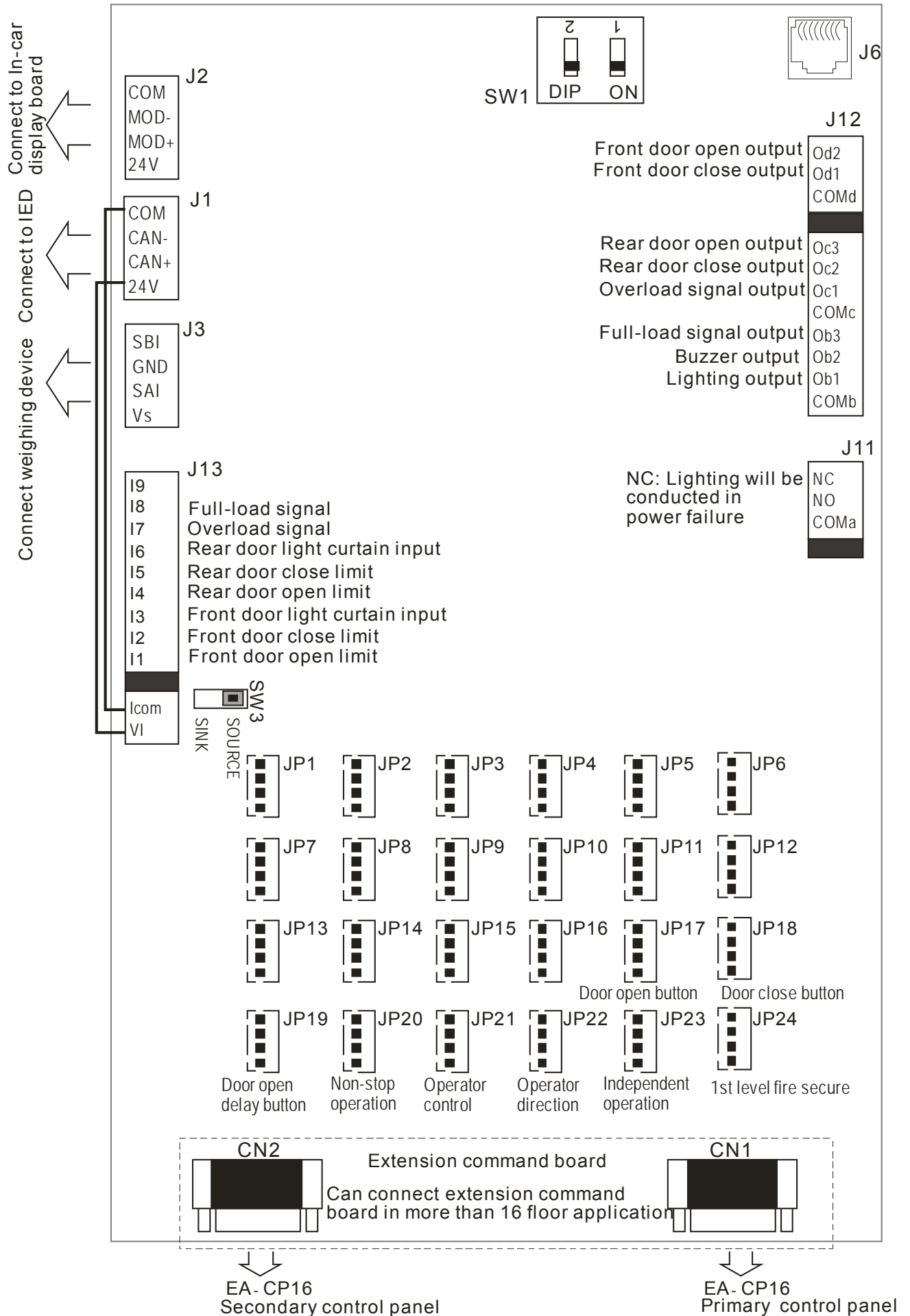

Figure D1-10

Integrated Elevator car command board (EA-CTP01) layout



Car-top board layout EA-CT01

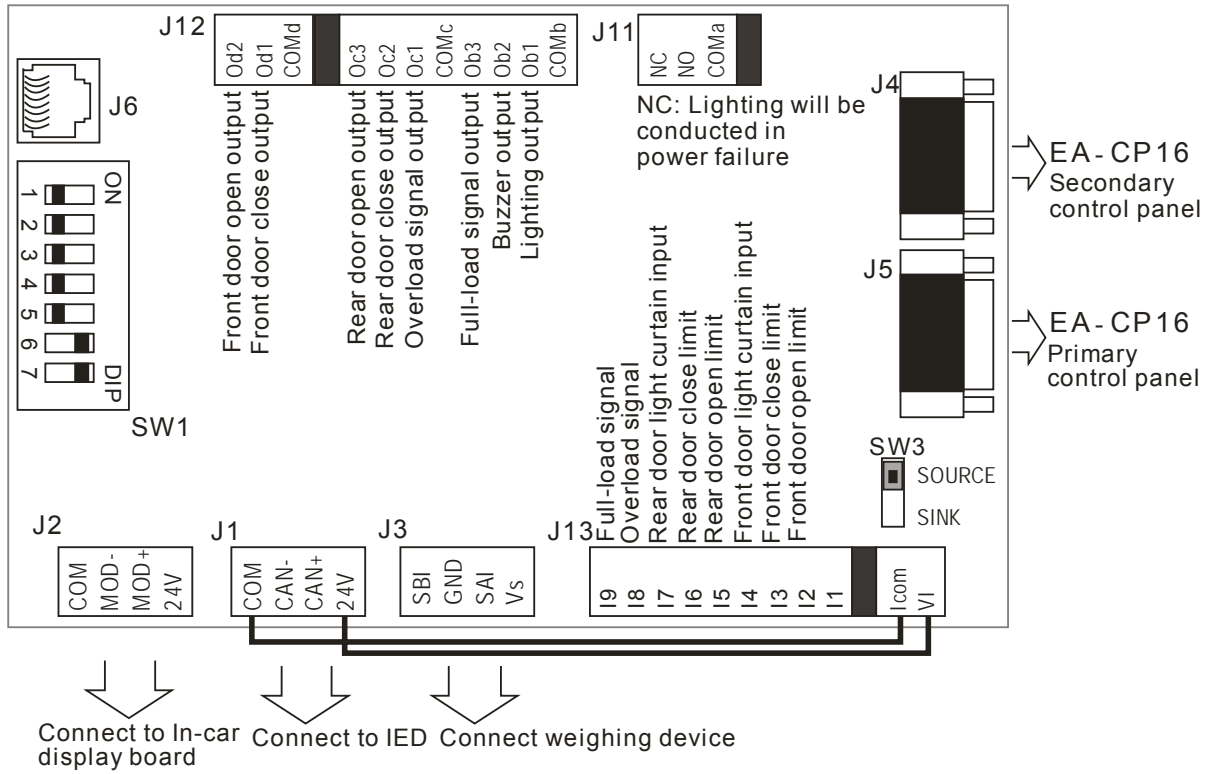

Figure D1-11

Car-top board EA-CT01 SOURCE Mode

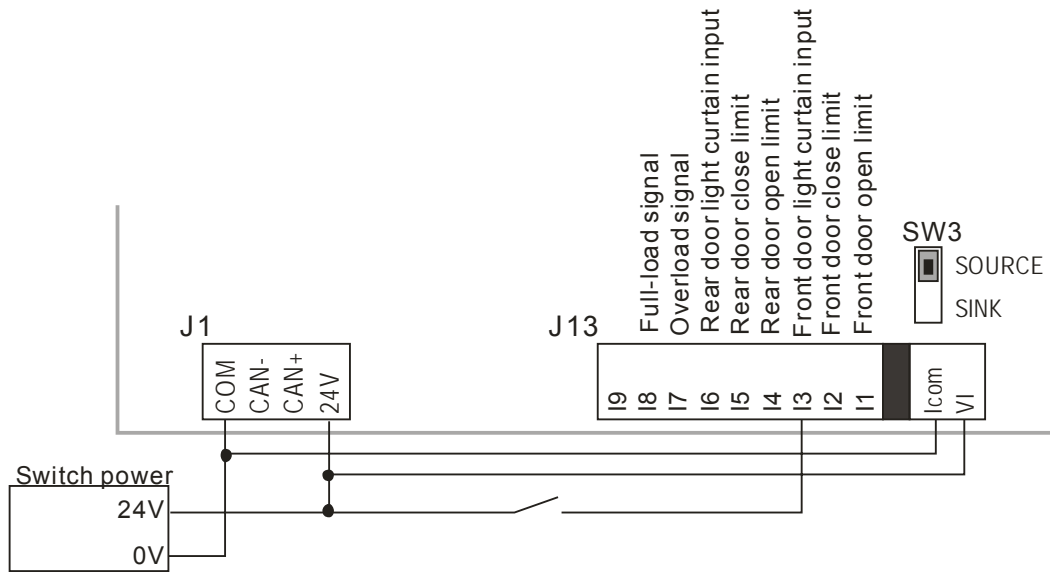

Figure D1-12

Car-top board EA-CT01 SINK Mode



圖 D1-13

Elevator car Command board EA-CP16

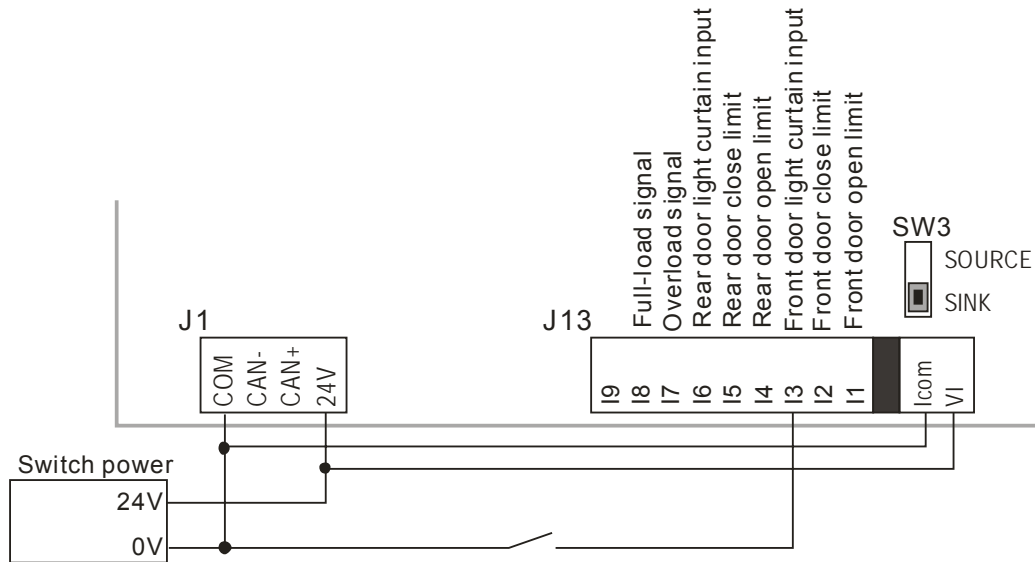
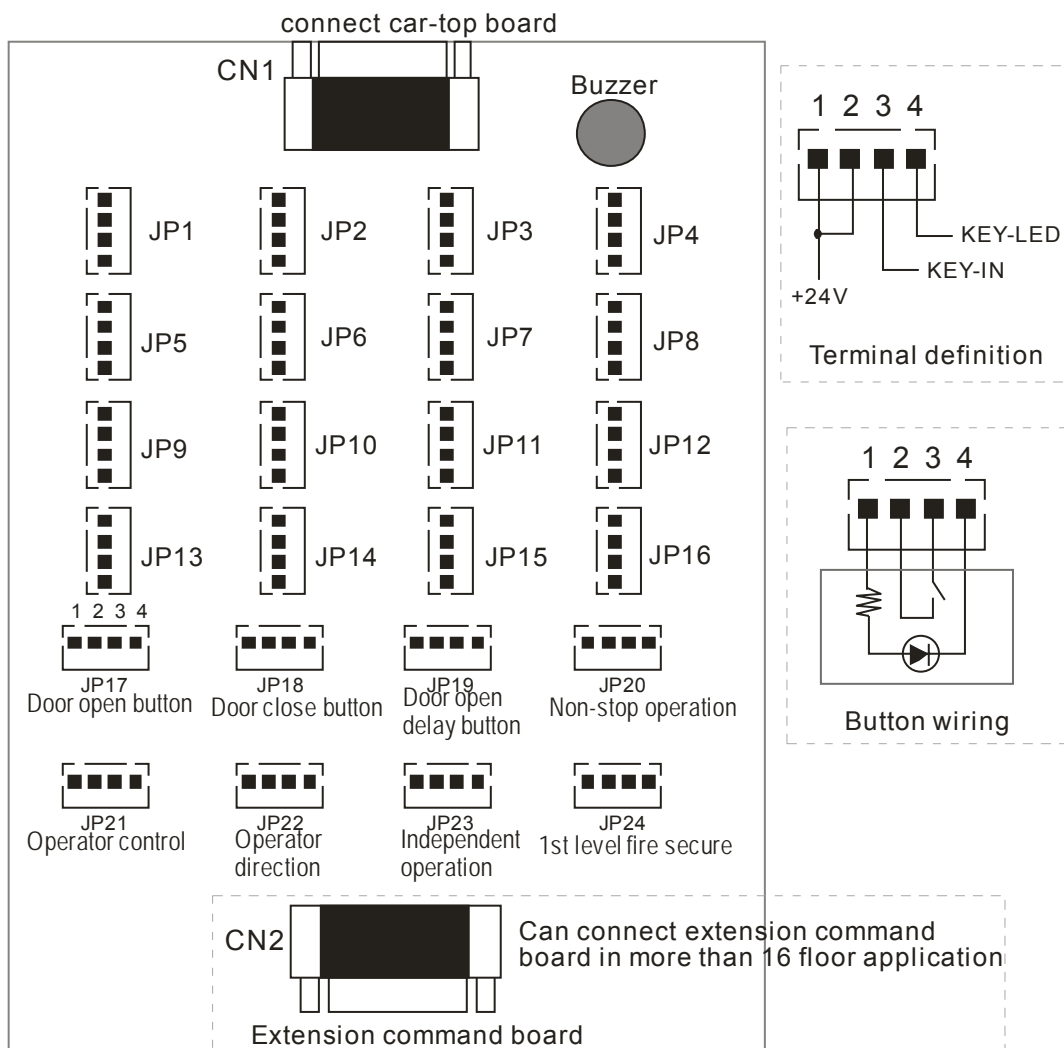

Figure D1-14

Vertical display board EA-FM02MV & Vertical/Horizontal display board EA-FM02MH

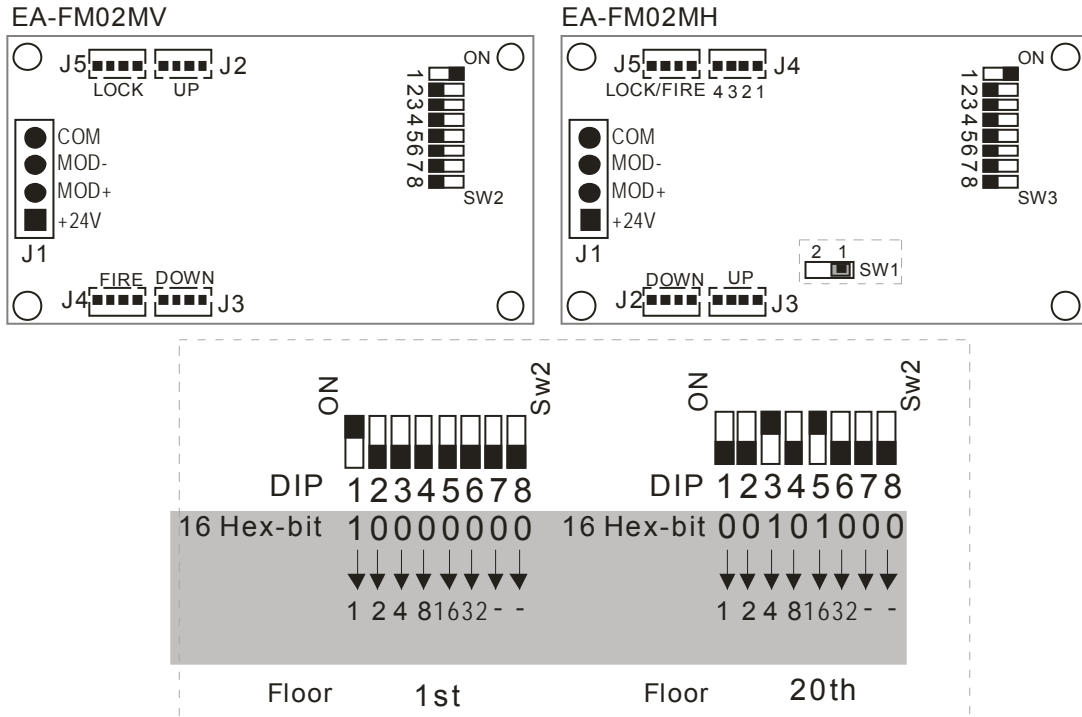
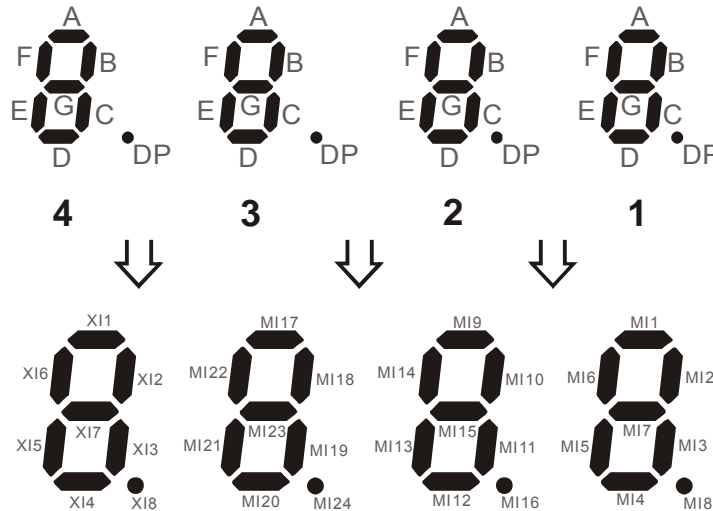
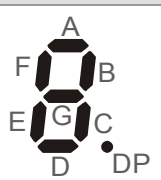

Figure D1-15

Digital Operation Panel



LED	LED Segment	LED Segment "ON" indicates	LED Segment "OFF" indicates
 <p>1</p>	A	MI1 Input function is valid	MI1 Input function is invalid
	B	MI2 Input function is valid	MI2 Input function is invalid
	C	MI3 Input function is valid	MI3 Input function is invalid
	D	MI4 Input function is valid	MI4 Input function is invalid
	E	MI5 Input function is valid	MI5 Input function is invalid
	F	MI6 Input function is valid	MI6 Input function is invalid
	G	MI7 Input function is valid	MI7 Input function is invalid
	DP	MI8 Input function is valid	MI8 Input function is invalid

 <p>2</p>	A	MI9 Input function is valid	MI9 Input function is invalid
	B	MI10 Input function is valid	MI10 Input function is invalid
	C	MI11 Input function is valid	MI11 Input function is invalid
	D	MI12 Input function is valid	MI12 Input function is invalid
	E	MI13 Input function is valid	MI13 Input function is invalid
	F	MI14 Input function is valid	MI14 Input function is invalid
	G	MI15 Input function is valid	MI15 Input function is invalid
	DP	MI16 Input function is valid	MI16 Input function is invalid
 <p>3</p>	A	MI17 Input function is valid	MI17 Input function is invalid
	B	MI18 Input function is valid	MI18 Input function is invalid
	C	MI19 Input function is valid	MI19 Input function is invalid
	D	MI20 Input function is valid	MI20 Input function is invalid
	E	MI21 Input function is valid	MI21 Input function is invalid
	F	MI22 Input function is valid	MI22 Input function is invalid
	G	MI23 Input function is valid	MI23 Input function is invalid
	DP	MI24 Input function is valid	MI24 Input function is invalid
 <p>4</p>	A	XI1 Input function is valid	XI1 Input function is invalid
	B	XI2 Input function is valid	XI2 Input function is invalid
	C	XI3 Input function is valid	XI3 Input function is invalid
	D	XI4 Input function is valid	XI4 Input function is invalid
	E	XI5 Input function is valid	XI5 Input function is invalid
	F	XI6 Input function is valid	XI6 Input function is invalid
	G	XI7 Input function is valid	XI7 Input function is invalid
	DP	XI8 Input function is valid	XI8 Input function is invalid

Figure D1-16

3 Single Elevator Commissioning

■ Basic system settings

Basic parameters

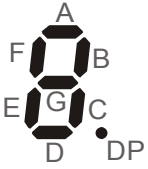
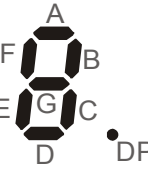
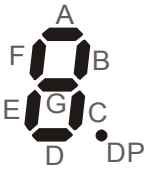
※ Before commissioning, it is necessary to configure the following basic parameters. Basic motor parameter settings can be configured according to the motor's nameplate.

Parameter	Name of the parameter	Default value	Parameter range
01-01	Parameter management setting	0	0: No function 1: Parameter write proof 3: Show the hidden parameter(☑) 8: Panel operation is disable 9: Parameter reset (Base frequency is 50Hz) 10: Parameter reset (Base frequency is 60Hz)
01-02	Control method	0	0: V/F control 1: V/F control + Encoder (VFPG) 2: Sensorless vector control (SVC) 3: FOC vector control + Encoder (FOCPG) 4: Torque control + Encoder (TQCPG) 8: FOC PM control (FOCPM)
01-03	System control	0480Hex	bit 0=0: No function bit 0=1: ASR automatic adjustment, PDFF enable bit 7=0: No function bit 7=1: Startup position control is enabled bit 10=0: No function bit 10 = 1: Direct parking is enabled bit 15=0: No function bit 15=1: Magnetic pole detection is disabled when power on
01-04	Elevator speed	1.00 m/s	0.10 ~ 4.00 m/s
01-05	Maximum Output Frequency	60.00 Hz /50.00Hz	10.00 ~ 400.00Hz
01-08	Carrier Frequency	12 kHz	2 ~ 15kHz
02-00	Motor Auto Tuning	0	0: No function 1: Rolling test 2: Static test
02-01	Full-load Current of Motor	90% of the model's rated current	(30 ~ 120%) * the model's rated current (Amps)
02-02	Rated power of Motor	#.##	0.00 ~ 655.35kW
02-03	Rated speed of Motor (rpm)	1710	0~65535
02-04	Number of Motor Poles	4	2~96
02-05	Angle between Magnetic Pole and PG Origin	360.0°	0.0~360.0°
02-06	Output Direction Selection	0	0: Same as the configured direction 1: Opposite to the configured direction
02-07	Encoder type selection	0	0: No function 1: ABZ 2: ABZ + Hall 3: SIN/COS + Sinusoidal 4: SIN/COS + Endat 5: SIN/COS 6: SIN/COS + Hiperface
02-08	Encoder Pulse	600	1~25000
02-09	Encoder's input type setting	0	0: No function 1: Phases A/B are pulse inputs: Phase A is 90 degree leading Phase B with forward rotation 2: Phases A/B are pulse inputs: Phase B is 90 degree leading Phase A with forward rotation 3: Phase A is a pulse input; Phase B is the direction input:

			L is reverse direction and H is forward direction 4 : Phase A is a pulse input; Phase B is the direction input: L is forward direction and H is reverse direction 5: Single phase input
02-11	Rated frequency of Motor	60.00 Hz /50.00 Hz	0.00 ~ 400.00Hz
02-12	Rated voltage of Motor	230V Series: 220.0 460V Series: 440.0	230V Series: 0.0V ~ 255.0V 460V Series: 0.0V ~ 510.0V
02-13	No-load current of Motor	40% of the model's rated current	0 ~ Motor's full-load current (Parameter 02-01) setting
02-14	Stator Resistance (Rs) of Motor	Automatic verification after motor tuning	0.000~65.535Ω
02-15	Rotor Resistance (Rr) of Motor	Automatic verification after motor tuning	0.000~65.535Ω
02-16	Magnetizing Inductance (Lm) of Motor	Automatic verification after motor tuning	0.0~6553.5mH
02-17	Stator Inductance (Lx) of Motor	Automatic verification after motor tuning	0.0~6553.5mH
02-18	Back Electromotive Force	Automatic verification after motor tuning	0.0~6553.5Vrms
06-10	Floor search speed	0.08 m/s	0.10 ~ 4.00m/s
06-11	Inspection speed	0.08 m/s	0.10 ~ 4.00m/s
06-12	Leveling speed	0.15 m/s	0.10 ~ 4.00m/s
06-13	Fast operating speed	0.25 m/s	0.10 ~ 4.00m/s
08-00	Elevator's topmost floor	5	Floor 1 ~ 47
08-02	Elevator base station	1	Floor 1 ~ 47
08-05	Service floor 1	FFFF	0~FFFF
08-06	Service floor 2	FFFF	0~FFFF
08-07	Service floor 3	FFFF	0~FFFF
08-51	Automatic fault resets time	0	0: Disable 0 ~ 30000 times
08-52	Interval of automatic reset	0	0 ~ 60 seconds
08-48	Factory function 1	0080h	0~65535
08-49	Factory function 2	0	0~65535
09-02	Door motor 1 Service Floor 1	FFFF	0~FFFF
09-03	Door motor 1 Service Floor 2	FFFF	0~FFFF
09-04	Door motor 1 Service Floor 3	FFFF	0~FFFF

Multi-function input terminals: Determine whether the external terminal signal is normally open (N.O.) or normally closed (N.C.); configure the following parameters after the device is supplied with power:

※ Parameters 03-00=1 is used for inspection (N.O.); configure it as 101 for inspection (N.C.) (Please refer to Figure D1-5)

Parameter	Name of the parameter	NO	NC	Parameter range
03-00	Multi-function input command 1 (MI1)	1	101	0: No function 1: Inspection signal
03-01	Multi-function input command 2 (MI2)	2	102	2: Inspection up-going 3: Inspection down-going
03-02	Multi-function input command 3 (MI3)	3	103	4: Upper leveling signal 5: Lower leveling signal
03-03	Multi-function input command 4 (MI4)	4	104	6: Door position input 7: Door inter-lock circuit feedback
03-04	Multi-function input command 5 (MI5)	5	105	8: Brake circuit feedback 9: Operation output feedback
03-05	Multi-function input command 6 (MI6)	6	106	10: Safety circuit feedback 11: Up-most limit signal
03-06	Multi-function input command 7 (MI7)	7	107	12: Upward 1 st level forced deceleration 13: Upward 2 nd level forced deceleration
03-07	Multi-function input command 8 (MI8)	8	108	14: Upward 3 rd level forced deceleration 15: Down-most limit signal
03-08	Multi-function input command 9 (MI9)	9	109	16: Downward 1 st level forced deceleration 17: Downward 2 nd level forced deceleration
03-09	Multi-function input command 10 (MI10)	10	110	18: Downward 3 rd level forced deceleration 19: Door pre-opening output feedback
03-10	Multi-function input command 11 (MI11)	11	111	20: Safety circuit feedback 2 21: Brake close feedback 2
03-11	Multi-function input command 12 (MI12)	12	112	22: Door close circuit feedback 2 23: Overload input
03-12	Multi-function input command 13 (MI13)	13	113	24: Full-load input 25: Fire signal
03-13	Multi-function input command 14 (MI14)	14	114	26: Fire mode 27: Light curtain signal 1
03-14	Multi-function input command 15 (MI15)	15	115	28: Light curtain signal 2 29: Elevator lock signal
03-15	Multi-function input command 16 (MI16)	16	116	30: Emergency power supply feedback
03-16	Multi-function input command 17 (MI17)	17	117	
03-17	Multi-function input command 18 (MI18)	18	118	
03-18	Multi-function input command 19 (MI19)	0	0	
03-19	Multi-function input command 20 (MI20)	0	0	
03-20	Multi-function input command 21 (MI21)	0	0	
03-21	Multi-function input command 22 (MI22)	0	0	
03-22	Multi-function input command 23 (MI23)	0	0	
03-23	Multi-function input command 24 (MI24)	0	0	

Multi-function input terminals: Determine whether the external terminal signal is normally open (N.O.) or normally closed (N.C.); configure the following parameters after the device is supplied with power:

※ Please refer to Figure D1-5

Parameter	Name of the parameter	NO	NC	Parameter range
03-40	Multi-function output RA	1	101	0: No function
03-41	Multi-function output MRA	2	102	1: Motor's solenoid valve control output
03-42	Multi-function output R1A	3	103	2: Mechanical brake release
03-43	Multi-function output R2A	0	0	3: Mechanical brake enhanced release
03-44	Multi-function output R3A	0	0	4: Mechanical brake, electromagnetic contactor normal
03-45	Multi-function output R4A	0	0	5: Fault output
03-46	Multi-function output R5A	0	0	6: Operation monitoring
03-47	Multi-function output R6A	0	0	7: Group control ready
				8: Door pre-opening contactor output
				9: Door motor 1 open
				10: Door motor 1 close
				11: Door motor 2 open
				12: Door motor 2 close
				13: Door inter-lock circuit output
				14: Emergency power output
				15: PM motor three-phase short circuit output

Settings for various accessory cards

Car-top board EA-CT01 input terminals & Command board EA-CP16 Input Terminals

※ Please refer to Figures D1-6 ~ D1-12

Parameter	Name of the parameter	NO	NC	Parameter range
10-00	Car-top board input command I1	1	101	0: No function
10-01	Car-top board input command I2	2	102	1: Front door open limit
10-02	Car-top board input command I3	3	103	2: Front door close limit
10-03	Car-top board input command I4	5	105	3: Front door light curtain input
10-04	Car-top board input command I5	6	106	4: Front door open request
10-05	Car-top board input command I6	7	107	5: Rear door open limit
10-06	Car-top board input command I7	9	109	6: Rear door close limit
10-07	Car-top board input command I8	10	110	7: Rear door light curtain input
10-16	Command board 1 JP17	11	111	8: Rear door open request
10-17	Command board 1 JP18	12	112	9: Overload input
10-18	Command board 1 JP19	13	113	10: Full-load input
10-19	Command board 1 JP20	14	114	11: Front door open button
10-20	Command board 1 JP21	15	115	12: Front door close button
10-21	Command board 1 JP22	16	116	13: Front door open delay button
10-22	Command board 1 JP23	17	117	14: VIP mode switch
				15: Operator control switch
				16: Operator non-stop control switch
				17: Independent operation switch
				18: 1 st level fire rescue switch
				19: Car-top inspection switch
				20: Car-top inspection up-going
				21: Car-top inspection down-going
				22: Emergency stop input
				23: Light control input
				24: Fan control input
				25: Rear door open button
				26: Rear door close button
				27: Rear door open delay button
				28: Operator direction up-going switch
				29: Operator direction down-going switch

10-23	Command board 1 JP24	18	118	30: Jog up-going 31: Jog down-going 32: Light load switch input 33: Front door safety panel 34: Rear door safety panel
-------	----------------------	----	-----	--

Car-top board EA-CT01 output terminals & Command board EA-CP16 Output Terminals

※ Please refer to Figures D1-6 ~ D1-12

Parameter	Name of the parameter	NO	NC	Parameter range
10-24	Car-top board output command Od2	1	101	0: No function 1: Front door open output 2: Front door close output 3: Rear door open output 4: Rear door close output 5: Overload signal output 6: Full-load signal output 7: Buzzer output 8: Light output 9: Fan output 10: Front door is opening 11: Front door is closing 12: Front door open delay display 13: Non-stop operation display 14: Operator control output 15: Operator direction change display 16: Independent operation display 17: 1 st level fire rescue display 18: Elevator landing 19: Elevator stop 20: Elevator up-going output 21: Elevator down-going output 22: Error display output 23: Front door reset output 24: Front door slow closing output 25: Rear door reset output 26: Rear door slow closing output 27: Rear door is opening 28: Rear door is closing 29: Rear door open delay display
10-25	Car-top board output command Od1	2	102	
10-26	Car-top board output command Oc3	3	103	
10-27	Car-top board output command Oc2	5	105	
10-28	Car-top board output command Oc1	6	106	
10-29	Car-top board output command Ob3	7	107	
10-30	Car-top board output command Ob2	9	109	
10-31	Car-top board output command Ob1	10	110	
10-48	Car-top board output command Oa	0	0	
10-40	Command board 1 JP17	10	110	
10-41	Command board 1 JP18	11	111	
10-42	Command board 1 JP19	12	112	
10-43	Command board 1 JP20	13	113	
10-44	Command board 1 JP21	14	114	
10-45	Command board 1 JP22	15	115	
10-46	Command board 1 JP23	16	116	
10-47	Command board 1 JP24	17	117	
10-49	Car-top input direction 1	0000H	0~66535	
10-50	Car-top input direction 2	0000H	0~66535	
10-51	Car-top output direction 1	0000H	0~66535	
10-52	Car-top output direction 2	0000H	0~66535	

Door control parameter settings

Parameter	Name of the parameter	Default value	Parameter range
09-00	Number of door motors	0	0: 1 unit 1: 2 units
09-01	Car-top board software version	0	0~99
09-02	Door motor 1 Service Floor 1	FFFF	0~FFFF
09-03	Door motor 1 Service Floor 2	FFFF	0~FFFF
09-04	Door motor 1 Service Floor 3	FFFF	0~FFFF
09-05	Door motor 2 Service Floor 1	FFFF	0~FFFF
09-06	Door motor 2 Service Floor 2	FFFF	0~FFFF
09-07	Door motor 2 Service Floor 3	FFFF	0~FFFF
09-08	Door open time protection	10	5 ~ 99 seconds
09-09	Door close time protection	15	5 ~ 99 seconds
09-10	Door open/close times	0	0 ~ 20 times
09-11	Door status at movement base station	0	0: Normal door closing 1: Open door and wait
09-12	Door open holding time by external display board	5	1 ~ 30 seconds
09-13	Door open holding time by in-car display board	3	1 ~ 30 seconds
09-14	Door open holding time at base station	10	1 ~ 30 seconds
09-15	Delay time for arrival alarm output	0	0 ~ 1000ms

Service Floor Parameters

Parameter	Name of the parameter	Default value	Parameter range
08-05	Service floor 1	FFFF	0~FFFF
08-06	Service floor 2	FFFF	0~FFFF
08-07	Service floor 3	FFFF	0~FFFF

External display board/ In-car display board**External display board/ In-car display board: Installation**

Plug the connector of Modbus communication cable into J1; plug the connectors of the Upward and Downward buttons into J2 and J3, respectively; plug the connectors for the Fireman and Elevator Lock switches into J4 and J5, respectively.(Please refer to the following figure)

External display board: Floor setting

With the SW2(EA-FM02MV) & SW3 (EA-FM02MH) DIP address setting, up to 64 floors can be configured currently; the 8th bit is the termination resistor for communication; dial it to the ON position for the lowest floor. (Please refer to the following figure:)

SW1 in EA-FM02MH is to switch vertical / horizontal display. When SW1 is in 1, EA-FM02MH will be vertical display; when SW1 is in 2, EA-FM02MH will be horizontal display

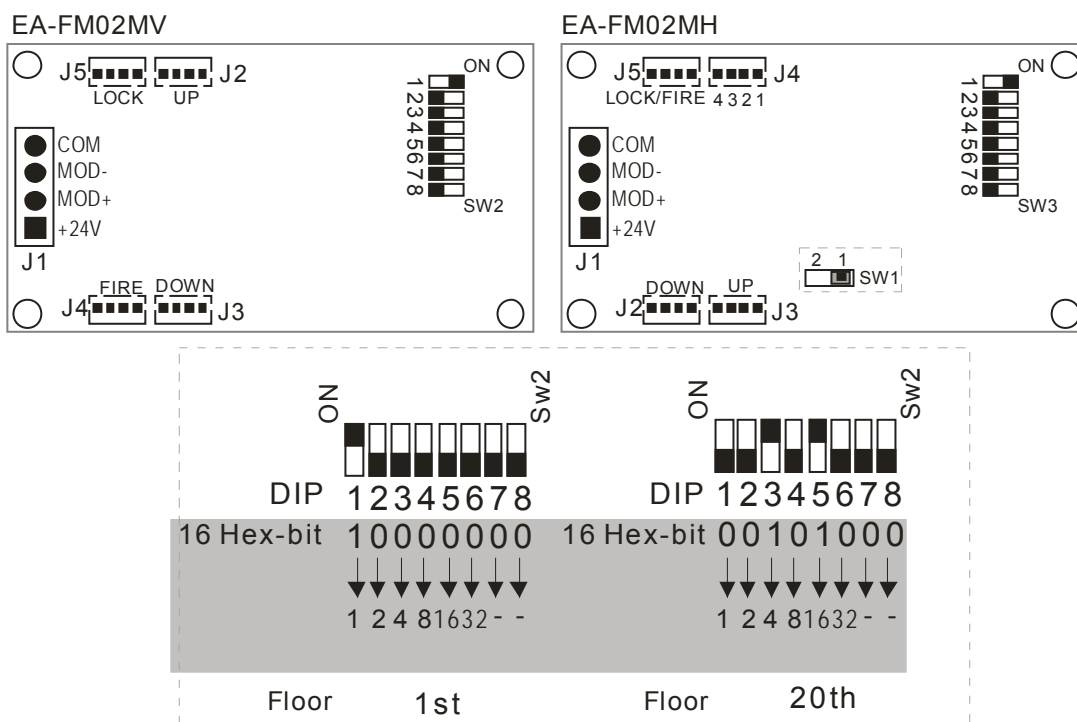

Input/Output Pin Assignments

Name of the terminal	Definition of function	Description of the terminal
J1	Modbus communication and power cord terminals MOD+/MOD- are the communication lead wires for Modbus +24V/COM are the 24V power and the common ground wires, respectively	Communication port and the car-top communication Power requirements: +24V±5% Load capability ≥ 400mA
J2	Upward call button interface: Pin 2 and Pin 3 are wires for number of input switches; Pin 1 and Pin 4 are used for button indicator output signal control	1、The button is a normally open button 2、The maximum load capability of the button indicator output is 30mA.
J3	Downward call button interface: Pin 2 and Pin 3 are wires for number of input switches; Pin 1 and Pin 4 are used for button indicator output signal control	
J4	EA-FM02MV : Fire button interface: Pin 2 and Pin 3 are wires for number of input switches; Pin 1 and Pin 4 are used for button indicator output signal control EA-FM02MH: For the indicator of up-going and down-going position attained	
J5	EA-FM02MV: Elevator lock button interface: Pin 2 and Pin 3 are wires for number of input switches; Pin 1 and Pin 4 are used for button indicator output signal control EA-FM02MH: Door lock and fire indication are Pin 4 and Pin 3, respectively.	

The specific assignments of the 4 pins in the 4-pin interface of the EA-FM02MV are as shown below; the definitions of the labels in the figure are: +24 V (24V power), KEY-IN (button input signal), and KEY-LED (button indicator output)

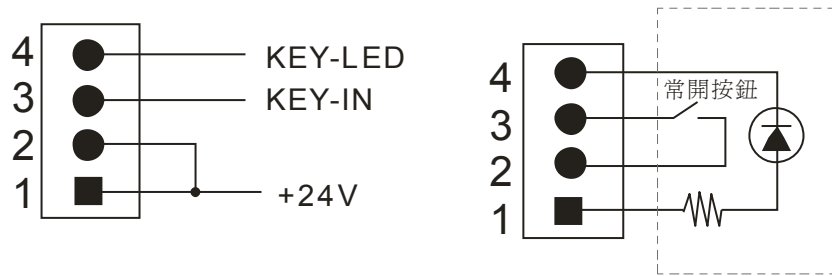

Pin assignments of the terminal interface and its external connection

The specific assignments of the 4 pins in the 4-pin interface of the EA-FM02MH are as shown below; the definitions of the labels in the figure are: +24 V (24V power), KEY-IN (button input signal), KEY-LED (button indicator output), LED-FIRE (fire indicator output), LED-LOCK (door lock indicator output), KEY-FIRE (fire input signal), and KEY-LOCK (door lock input signal).

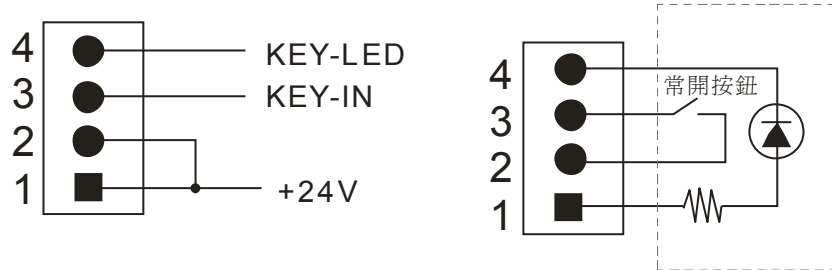

Pin assignments of the J2 and J3 terminal interfaces and their external connection

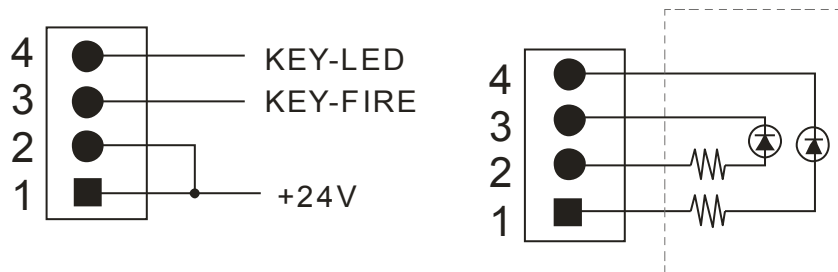

Pin assignments of the J4 terminal interface and the external connection

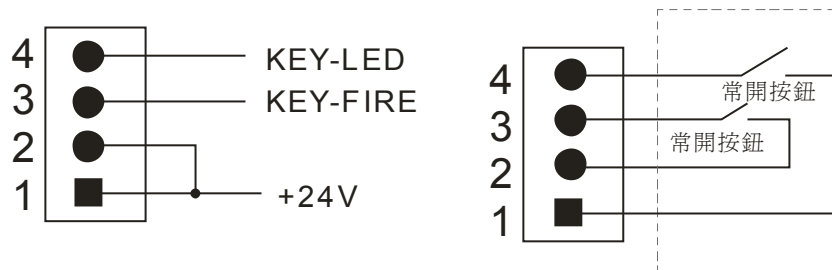

Pin assignments of the J5 terminal interface and its external connection

In-car display board:

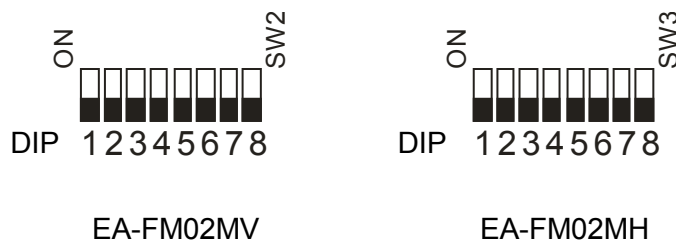

1、Floor address setting and installation

- 1) Toggle NO.1~8 DIP of SW2(EA-FM02MV) & SW3 (EA-FM02MH) to off, the in-car display mode is activated.
- 2) SW1 in EA-FM02MH is to switch vertical / horizontal display. When SW1 is in 1, EA-FM02MH will be vertical display; when SW1 is in 2, EA-FM02MH will be horizontal display.
- 3) Plug Modbus cable terminal into J1, up-going and down-going button into J2, J3 respectively, and door inter-lock and fire mode into J4, J5.



2、EA-FM02MV display instructions

Chart	Explanation
Upward arrow	Elevator is stopping, and about to going up
Upward arrow moving	Elevator is going up
Downward arrow	Elevator is stopping, and about to going down
Downward arrow moving	Elevator is going down
No display	Elevator is in stop mode or disconnect with IED/ Elevator lock mode
Display "X" 	Elevator failure or communication abnormality



3、EA-FM02MH display instructions

A. Horizontal display

Chart	Explanation
Upward arrow	Elevator is stopping, and about to going up
Upward arrow moving	Elevator is going up
Downward arrow	Elevator is stopping, and about to going down
Downward arrow moving	Elevator is going down
No display	Elevator is in stop mode or disconnect with IED/ Elevator lock mode

Display "X" 	Elevator failure or communication abnormality
Display wrench 	Elevator is under inspection

B. Vertical display

Chart	Explanation
Upward arrow	Elevator is stopping, and about to going up
Upward arrow moving	Elevator is going up
Downward arrow	Elevator is stopping, and about to going down
Downward arrow moving	Elevator is going down
No display	Elevator is in stop mode or disconnect with IED/ Elevator lock mode
Display "X" 	Elevator failure or communication abnormality
Display wrench 	Elevator is under inspection

External display board parameters

Parameter	Name of the parameter	Default value	Parameter range
08-38	Disable external display board	0	0: Car-top board is valid, external display board is valid 1: Car-top board is valid, external display board is invalid 2: Car-top board is invalid, external display board is valid 3: Car-top board is invalid, external display board is invalid
08-39	Disable door open	0	0: Door open is enabled 1: Door open is disabled

The communication interface is configured by the parameter 08-38.

When the parameter 08-38 is set as 0,

external display board communication and car-top board communication are valid.

When the parameter 08-38 is set as 1,

car-top board communication is valid but the external display board communication is invalid.

When the parameter 08-38 is set as 2,

car-top board communication is invalid but external display board communication is valid.

When the parameter 08-38 is set as 3,

both external display board communication and car-top board communication are valid.

Return to the base station, fire, elevator lock

Parameter	Name of the parameter	Default value	Parameter range
08-02	Elevator base station	1	Floor 1 ~ 47
08-03	Fire base station	1	Floor 1 ~ 47
08-04	Elevator lock base station	1	Floor 1 ~ 47

Floor indication

※ Please refer to the description of terminals of Encode EMED-PGHSD

Parameter	Name of the parameter	Default value	Parameter range
05-00	Physical floor 1 indication	1	0~9999 Settings: XX YY XX: Tens digit YY: Units digit 00='0' 01='1' 02='2' 03='3' 04='4' 05='5' 06='6' 07='7'
05-01	Physical floor 2 indication	2	
05-02	Physical floor 3 indication	3	
05-03	Physical floor 4 indication	4	
05-04	Physical floor 5 indication	5	
05-05	Physical floor 6 indication	6	
05-06	Physical floor 7 indication	7	
05-07	Physical floor 8 indication	8	
05-08	Physical floor 9 indication	9	
05-09	Physical floor 10 indication	100	
05-10	Physical floor 11 indication	101	
05-11	Physical floor 12 indication	102	
05-12	Physical floor 13 indication	103	
05-13	Physical floor 14 indication	104	
05-14	Physical floor 15 indication	105	
05-15	Physical floor 16 indication	106	
05-16	Physical floor 17 indication	107	
05-17	Physical floor 18 indication	108	
05-18	Physical floor 19 indication	109	

05-19	Physical floor 20 indication	200	08='8'
05-20	Physical floor 21 indication	201	09='9'
05-21	Physical floor 22 indication	202	10='A'
05-22	Physical floor 23 indication	203	11='B'
05-23	Physical floor 24 indication	204	12='G'
05-24	Physical floor 25 indication	205	13='H'
05-25	Physical floor 26 indication	206	14='L'
05-26	Physical floor 27 indication	207	15='M'
05-27	Physical floor 28 indication	208	16='P'
05-28	Physical floor 29 indication	209	17='R'
05-29	Physical floor 30 indication	300	18='-'
05-30	Physical floor 31 indication	301	19=""
05-31	Physical floor 32 indication	302	20='X'
05-32	Physical floor 33 indication	303	21=up_icon
05-33	Physical floor 34 indication	304	22=down_icon
05-34	Physical floor 35 indication	305	
05-35	Physical floor 36 indication	306	
05-36	Physical floor 37 indication	307	
05-37	Physical floor 38 indication	308	
05-38	Physical floor 39 indication	309	
05-39	Physical floor 40 indication	400	
05-40	Physical floor 41 indication	401	
05-41	Physical floor 42 indication	402	
05-42	Physical floor 43 indication	403	
05-43	Physical floor 44 indication	404	
05-44	Physical floor 45 indication	405	
05-45	Physical floor 46 indication	406	
05-46	Physical floor 47 indication	407	

Encode EMED-PGHSD

※ Please refer to Figure D1-15

Parameter	Name of the parameter	Default value	Parameter range
02-07	Encoder type selection	0	0: No function 1: ABZ 2: ABZ + Hall 3: SIN/COS + Sinusoidal 4: SIN/COS + Endat 5: SIN/COS 6: SIN/COS + Hiperface
02-08	Number of pulses for each turn of the encoder	600	1~25000
02-09	Encoder's input type setting	0	0: No function 1: Phases A/B are pulse inputs: Phase A is 90 degree leading Phase B with forward rotation 2: Phases A/B are pulse inputs: Phase B is 90 degree leading Phase A with forward rotation 3: Phase A is a pulse input; Phase B is the direction input: L is reverse direction and H is forward direction 4 : Phase A is a pulse input; Phase B is the direction input: L is forward direction and H is reverse direction 5: Single phase input

Function of sinusoidal type ENCODER

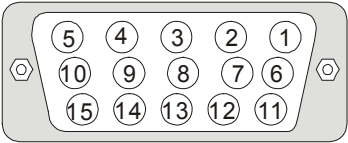
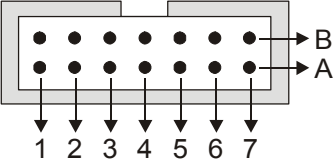
J3 (refer to Figure D1-10)		Heidenhain ERN1387		Heidenhain ECN1313 (EnDat)
				
Terminal No.	Name of the terminal	Terminal No.	Name of the terminal	Name of the terminal
1	B-	5a	B-	B-
2	NC	NC	NC	0V
3	Z+	4b	R+	0V
4	Z-	4a	R-	0V
5	A+	6b	A+	A+
6	A-	2a	A-	A-
7	0V	5b	0V	0V
8	B+	3b	B+	B+
9	+5V	1b	UP	VP
*10	SIN	7b	C+	Data-
*11	SIN'	1a	C-	Data+
12	COS	2b	D+	CLOCK+
13	COS'	6a	D-	CLOCK-
14	NC	-	-	VP
15	NC	-	-	0V

※ For more information about the encoder, please refer to Appendix B B-5-2

※ EMED-PGHSD J3 supports two connection configurations; in the Table shown above, the assignments of Terminals 10 and 11 are different; when the parameter 02-12 is set as 0000h, the information shown in the table shown above are valid; when the parameter 02-12 is set as 0004h, Terminal No. 10=C- and Terminal No. 11=C+.

■ Motor Tuning

Enter the data shown on the motor nameplate

Parameter	Name of the parameter	Default value	Parameter range
01-02	Control method	0	0: V/F control 1: V/F control + Encoder (VFPG) 2: Sensorless vector control (SVC) 3: FOC vector control + Encoder (FOCPG) 4: Torque control + Encoder (TQCPG) 8: FOC PM control (FOCPM)
01-04	Elevator speed	1.00	0.10 ~ 4.00 m/s
01-05	Maximum Output Frequency	60.00/ 50.00	10.00 ~ 400.00Hz
02-00	Motor Auto Tuning	0	0: No function 1: Rolling test 2: Static test
02-01	Full-load Current OF Motor	###	(30 ~ 120%) * the model's rated current (Amps)
02-02	Rated power of Motor	###	0.00 ~ 655.35kW
02-03	Rated speed of Motor (rpm)	1710	0~65535
02-04	Numbers of Motor poles	4	2~96
02-05	Angle between Magnetic Pole and PG Origin	360.0	0.0~360.0°
02-06	Output Direction Selection	0	0: Same as the configured direction 1: Opposite to the configured direction
02-07	Encoder type selection	0	0: No function 1: ABZ 2: ABZ + Hall 3: SIN/COS + Sinusoidal 4: SIN/COS + Endat 5: SIN/COS 6: SIN/COS + Hiperface
02-08	Encoder pulses	0	1~25000
02-09	Encoder Input type setting	600	0: No function 1: Phases A/B are pulse trains: Phase A is 90 degree leading Phase B with forward rotation 2: Phases A/B are pulse trains: Phase B is 90 degree leading Phase A with forward rotation 3: Phase A is a pulse train; Phase B is the direction sign: L is reverse and H is forward 4: Phase A is a pulse train; Phase B is the direction sign: L is forward and H is reverse 5: Single phase input
02-10	U, V, W input mode selection	0	0: Z signal is at the falling edge of Phase U 1: Z signal is at the leading edge of Phase U
02-11	Rated frequency of Motor	60.00/ 50.00	0.00 ~ 400.00Hz
02-12	Rated voltage of Motor	220.0 440.0	230V Series: 0.0V ~ 255.0V 460V Series: 0.0V ~ 510.0V
02-14	Stator Resistance (Rs) of Motor	0.000	0.000~65.535Ω
02-17	Stator Inductance (Lx) of Motor	0.0	0.0~6553.5mH
02-18	Back Electromotive Force	0.0	0.0~6553.5Vrms
06-11	Inspection speed	0.08	0.10 ~ 4.00m/s

Synchronous Motor (PM)

It is recommended to allow the motor self-learn before engaging the steel wire rope. When the U V W phase sequence of a synchronous motor is changed, the encoder is replaced, or the encoder wiring is changed, it is necessary to recognize the encoder position angle again.

Tuning process of a synchronous motor without load:

The first set parameters are usually used for test in the factory before delivery, so it is necessary to execute the tuning process for both the control cabinet and the motor at the same time. Before the test is executed, please make sure the wiring of the contracting brake, the wiring of the output relay, and the settings of the control parameters are correct.

- ※ Enter the following parameters
01-05, 02-01~02-04, 02-11, 02-12
- ※ Parameters for the encoder
02-07~02-10
Control method: 01-02=8
- ※ Please make sure that the traction wheel is not hanging with any elevator car or load.
- ※ Set 02-00=1 for self-tuning without load. Use the inspection terminals to execute the self-learning control. Press the inspection Up or Down buttons on the control panel. When the message "TUNE" is shown on the panel, execute the following two consecutive operations:
 - (1) At the same time, the contracting brake is not activated, the output relay is switched on for motor self-learning. The motor's parameters are automatically written in 02-14, 02-17, and 02-18.
 - (2) After a few seconds, the contracting brake opens, the motor is rotating, and the encoder self-learning starts. The parameter values obtained from the tuning process will be automatically written in 02-05 for the encoder's origin offset angle.
- ※ After the tuning process is complete, please set 6-11= inspection speed, open the contracting brake, and run the motor without load to check if the operating current is extraordinarily large and if the motor is running normally. For any error, execute the self-tuning process again or modify 02-09 before executing the self-tuning again.
- ※ After the self-tuning process is complete, please recover the terminal status.

Caution:

- 1) During the self-learning process of the encoder, if "PGF2" failure message occurs, please modify the parameter 02-09 (for example: if it is originally 1, you can change it to 2) before executing the motor self-tuning process again.
- 2) During the learning process of the encoder, set the inspection direction be opposite to the actual operation direction, you can set parameters 02-06 to 1 to correct this problem without exchange the output wires for the motor.

Tuning process of a synchronous motor with load:

Usually, the load is the elevator car that is hanging in the hoistway, so the motor is not able to be separated from the load. Therefore, the motor tuning process is usually executed by the **inspection control** mode. Before the test is executed, please make sure the wiring of the contracting brake, the wiring of the output relay, and the settings of the control parameters are correct.

- ※ Make sure that the elevator is in the inspection mode.
- ※ Enter the following parameters
01-05, 02-01~02-04, 02-11, 02-12
- ※ Parameters for the encoder
02-07~02-10
Control method: 01-02=8
- ※ Please make sure the directions of the upward and downward movement when the traction wheel is hanging with the elevator car for operation.
- ※ Set 02-00=2 for self-tuning with load. Use the inspection terminals to execute the self-learning control. Press the inspection Up or Down buttons on the control panel. When the message "TUNE" is shown on the panel, execute the following two consecutive operations:
 - (1) In the beginning, the contracting brake is not activated, the output relay is switched on for motor self-learning. The obtained motor's parameters are automatically written in 02-14, 02-17, and 02-18.
 - (2) After a few seconds, the contracting brake opens and the motor is rotating for 3 turns to execute the encoder self-learning process. The parameter values obtained from the tuning process will be automatically written in Parameter 02-05 for the offset angle of the encoder's origin.
- ※ After the tuning process is complete, please set 6-11= inspection speed, open the contracting brake, and run the motor with empty car to check if the operating current is extraordinarily large and if the motor is running normally. For any error, execute the self-tuning process again or modify 02-09 before executing the self-tuning again.
- ※ After the self-tuning is complete, the elevator is still in the inspection mode waiting for inspection run to inspect the activation timing of the hoistway signals.

Caution:

- ※ If the tuning is not successful, the risk of elevator sudden fall may occur. It is recommended to execute the operation by two persons together: One presses the inspection button, the other handles the emergency stop button so as to shut off the power in time in case the elevator sudden fall occurs.
- ※ During the self-learning process of the encoder, if "PGF2" failure message occurs, please modify the parameter 02-09 (for example: if it is originally 1, you can change it to 2) before executing the motor self-tuning process again.
- ※ During the learning process of the encoder, set the inspection direction be opposite to the actual operation direction, you can set parameters 02-06 to 1 to correct this problem without exchange the output wires for the motor.
- ※ The deviation angle obtained from the encoder self-learning process with load may have some bias. It is recommended to execute the learning process twice both for the upward and downward movements and then take their average value.

Asynchronous Induction Motor (IM)

- Select the control mode: When the IM motor is used by the customer, please set the parameter 01-02=3

Parameter	0: V/F control
01-02	1: V/F control + Encoder (VFPG)
Contents	2: Sensorless vector control (SVC)
	3: FOC vector control + Encoder (FOCPG)
	4: Torque control + Encoder (TQCPG)
	8: FOC PM control (FOCPM)

NOTE: Configure the parameter settings according to the motor type (PM or IM) used by the customer

- Motor parameter automatic measurement

Motor Auto Tuning

Parameter	0: No function
02-00	1: Rolling test
Contents	2: Static testing

NOTE: The automatic measurement process does not need to release the brake. If a solenoid valve is installed between the driver and the motor, it is necessary to energize the solenoid valve. For the static measurement with a setting range of 2, it is necessary to enter the motor 02-13. During the automatic measurement, the digital operating panel may show the warning message "Auto tuning" till the measurement is complete. Then the panel may stop displaying the warning message and store the measurement result into parameters 02-14~02-17 .

NOTE: The automatic measurement for IM motor can also provide dynamic measurement.

Full-load current of Motor

Parameter	(30 ~ 120%) * the model's rated current (Amps)
02-01	
Contents	

Rated power of Motor

Parameter	Contents
02-02	0.00 ~ 655.35kW

Rated speed of Motor (rpm)

Parameter	Contents
02-03	0~65535

Numbers of Motor Poles

Parameter	Contents
02-04	2~96

"IM motor does not need the origin deviation measurement because the magnetic pole positioning is not required for an IM motor."

Hoistway self-learning

Please confirm the following conditions before executing the hoistway self-learning:

- (1) Make sure that the elevator satisfies the inspection running condition
 - ※ IED and the Car-top board: The IED and the car-top board communicate with each other through the CAN communication. If the communication is not normal, the IED may exert error messages.
 - ※ IED and External display board: The IED and the External display board communicate with each other through the MODBUS communication based on the address configured by parameters 08-00 and 08-01. If the communication is not normal, the parameters 00-54~00-56 may show the addresses with communication time-outs. If the communication is normal, the contents of 00-54~00-56 will be 0.
- (2) Make sure that the settings for the lowest and highest elevator floors (08-00~08-01) are configured and the corresponding values are correct. In addition, the settings for the lowest and highest floors must match the physical floors.
- (3) Make sure that the elevator can move to any target floor correctly. If the settings are incorrect, the hoistway self-learning process may have errors.
- (4) Check the hoistway signals 00-15~00-17.

In the inspection mode, execute the inspection operation can check the time sequence of the hoistway signals (upper/lower limits, upward/ downward forced deceleration, upper/lower leveling or the door area signal) are correct so as to ensure that the hoistway self-learning process can be completed normally.
- (5) Configure the movement speed and the system control method 06-10~06-13

When the hoistway self-learning starts, the elevator moves downwards at the inspection speed (06-11) to search for the position of the lower limit. After triggering downward 1st level forced deceleration switch, it keeps moving downwards at the leveling speed (06-12) to continue searching for the position of the lower limit. When the lower limit signal is triggered, it will move upwards at the floor search speed (06-10) to start the hoistway self-learning process; once it triggers upper 1st level forced deceleration switch, it will move upward at the leveling speed (06-12) to continue to search for the upper limit. After the upper limit is triggered, it moves at the operation speed (06-13) back to the 1st floor to execute the hoistway position confirmation again. After the movement stops, the hoistway self-learning is complete. It is recommended that the running speed 06-13 shall be set as half of the maximum speed of the elevator for the hoistway self-learning.

- (6) The hoistway self-learning process is executed as follows:
 - A Make sure that the elevator is in the inspection mode
 - B Set the parameter 08-50 as 1
 - C Switch back to the normal mode, i.e., the automatic hoistway self-learning command
- (7) When the system executes the hoistway self-learning command automatically, it will move downward at the inspection speed to search for the position of the lower limit, and then move upward to start the self-learning

process. After the self-learning process is complete, it will move fast back and level with the lowest floor. (The elevator will execute the hoistway signal self-learning according to the aforementioned sequence, and automatically set 08-50 as 0 after the learning process is complete. During the hoistway self-learning, if it is required to stop the process, manually set 08-50 as 0 so as to stop the elevator and enter the inspection state.)

Methods for interrupting self-learning:

A Switch back to the inspection mode

B Abnormal error message is generated

C While the hoistway self-learning command is executed, the parameter is set as 08-50=1 again.

- (8) Check the hoistway parameters 04-00~04-95 and parameters 06-23~06-38.

After the hoistway self-learning is complete, check if the absolute position of the floors corresponding to the hoistway parameter 04-00~04-95 are reasonable. It is allowed to use the inspection movement to move the elevator to each floor to check if the absolute positions match the hoistway parameters.

- (9) Set the floor indications 05-00~05-46

Set the floor indications 05-00~05-46 properly according to the elevator's operation environment. Refer to the description of 05-00~05-46 for the configuration detail.

- (10) Definition of upper/lower leveling: When the elevator is moving downward, the lower leveling signal is triggered first. When the elevator is moving upward, the upper leveling signal is triggered first.

- (11) When the elevator moves downward and level with the lowest floor and continues moving down, the lower leveling signal must be released before the lower limit signal is triggered. In this case, the upper leveling signal must always be valid.

- (12) When the elevator moves upward and level with the highest floor and continues moving up, the upper leveling signal must be released before the upper limit signal is triggered. In this case, the lower leveling signal must always be valid.

- (13) Make sure that the coercion deceleration distance and the upper/lower limits are correctly installed.

- (14) If the position of the leveling plate is re-adjusted, it is necessary to execute the hoistway self-learning process again.

※ The parameters 04-02 ~ 04-95 correspond to the upper/lower leveling for the floors 1 ~ 47. For a more detailed list of these parameters, please refer to Summary of Parameters.

※

Parameter	Name of the parameter	Default value	Parameter range
01-04	Elevator speed	1.00	0.10 ~ 4.00 m/s
08-00	Elevator's topmost floor	5	Floor 1 ~ 47
08-01	Elevator's down-most floor	1	Floor 1 ~ 47
08-02	Elevator base station	1	Floor 1 ~ 47
08-50	Hoistway self-learning	0	0: Stop hoistway self-learning 1: Start hoistway self-learning
06-11	Inspection speed	0.08	0.10 ~ 4.00m/s
06-12	Leveling speed	0.15	0.10 ~ 4.00m/s
06-23	Position of lower limit - high	0	0 ~ 9999m
06-24	Position of lower limit - low	0.0	0.0 ~ 999.9mm
06-25	Downward 1 st level forced deceleration position - high	0	0 ~ 9999m
06-26	Downward 1 st level forced deceleration position - low	0.0	0.0 ~ 999.9mm

06-27	Downward 2 nd level forced deceleration position - high	0	0 ~ 9999m
06-28	Downward 2 nd level forced deceleration position - low	0.0	0.0 ~ 999.9mm
04-00	Landing board length	0.0	0.0 ~ 999.9mm
04-01	Distance between upper and lower leveling signals	0.0	0.0 ~ 999.9mm
04-02	Floor 1 position - high	0	0 ~ 9999m
04-03	Floor 1 position - low	0.0	0.0 ~ 999.9mm
04-04	Floor 2 position - high	0	0 ~ 9999m
04-05	Floor 2 position - low	0.0	0.0 ~ 999.9mm
~	~	~	~
04-94	Floor 47 position - high	0	0 ~ 9999m
04-95	Floor 47 position - low	0.0	0.0 ~ 999.9mm

Fast car test run

※ Car's internal command test

Set the elevator in the automatic mode. Configure the parameter 08-34 by using the small keypad function menu to enter the single-floor command to check if the elevator is running according to the command.

※ Hall call command test

Set the elevator in the automatic mode. Configure the parameter 08-35 and 08-36 by using the small keypad function menu to enter the hall call up/down movement or execute the hall call command for each floor to check if the elevator is running according to the commands.

※ Door open/close function test

When the elevator reach the station at the leveling position, check if the door opens normally and the door open hold time meets the requirement: When the elevator responds to the call and starts to move, check if the door closes normally.

Parameter	Name of the parameter	Default value	Parameter range
08-34	Test floor 1	0	Floor 1 ~ 47
08-35	Test floor 2	0	Floor 1 ~ 47
08-36	Test floor 3	0	Floor 1 ~ 47

Fast car movement

After the fast car test run is complete correctly, set the elevator in the inspection state, configure or add the required functions, and then starts the commissioning of fast car movement.

※ Configure 08-48 and 08-49 according to the customer's actual on-site demands.

※ According to the actual on-site conditions, adjust the parameter group 08, configure the base station, fire, elevator lock base station (08-02 ~ 08-04) and service floor (08-05 ~ 08-07), group selection method, time-sharing services, and parallel peak control.

※ Safety circuit test

If any safety switch is activated, the safety circuit relay will release.

※ Door lock circuit test

If any hall door lock or car door lock is unlocked, the door lock relay is released.

※ Contracting brake contactor sticking test

While parking, the top-pressure contracting brake contactor should be protected by the system

※ Output contactor sticking test

While parking, the top-pressure output contactor should be protected by the system

※ Slipping protection function test

Move the elevator to the middle floor in the inspection mode. Remove the system leveling signal wires (to set the signal normally open) and then switch to the automatic mode, the elevator will find leveling at a low speed. Within 45 seconds, the system automatic protection is activated.

※ Elevator lock function test

- (1) If the elevator parks at a certain floor other than the base station, the elevator lock base station's elevator lock signal is triggered and the elevator door shall immediately close and not respond to any hall call. It will move fast back to the elevator lock base station. After the car stops, the door opens for a delay time and then the door closes and the light goes out. All the commands and hall calls are shut off, and the hall external displays go off.
- (2) If the elevator is running and the elevator lock base station's elevator lock signal is triggered, all the hall call commands will disappear. After the elevator responds to all the command one by one, it will not respond to any hall call but move fast back to the elevator lock base station. As the car stops and the door opens, the door closes after a time delay, the indicator goes off, all the commands and hall calls are shut off, and the hall external displays go off.
- (3) If the elevator parks at the elevator lock base station, after the base station's elevator lock signal is triggered, the elevator shall open the door and then close the door, turn off the light, shut off all the commands and hall calls, and turn off the hall displays. But the car's internal Door Open indicator is constantly lit.

Parameter	Name of the parameter	Default value (NO)	Parameter range
08-02	Elevator base station	1	Floor 1 ~ 47
08-03	Fire base station	1	Floor 1 ~ 47
08-04	Elevator lock base station	1	Floor 1 ~ 47
08-05	Service floor 1	FFFF	0~FFFF
08-06	Service floor 2	FFFF	0~FFFF
08-07	Service floor 3	FFFF	0~FFFF
08-48	Factory function 1	0	0~65535
08-49	Factory function 2	0	0~65535

Comfort adjustment

The comfort during the elevator's movement can be adjusted through the parameter group 06 so as to allow the elevator to provide a comfortable and smooth movement; however, the comfort of an elevator is influenced by various factors, for example, improper mechanical adjustments or parameter settings may lead to bad comfort during the elevator movement.

The mechanical factors that affect the comfort can be categorized in to several conditions listed below:

- (1) The surface smoothness of the elevator's guide rails, verticality of the installed guide rails, and the treatment of the joints between rails.
 - The verticality of the guide rails can affect not only the elevator's horizontal vibration but also its vertical vibration during movement.
 - If the joints between guide rails are not properly handled, the step-like motion at certain position may occur during the elevator's movement.

(2) Tightness of guide shoes

If the guide shoes are too tight, the step-like motion may occur as the elevator starts to move; meanwhile, the sudden braking motion may occur as the elevator is going to stop; if the guide shoes are too loose, the vibration may occur during the elevator's movement.

(3) The gap between the mechanical contracting brakes of the motor has great effect on the movement during starting and braking.

(4) The imbalance between the tensions of the elevator's steel wire ropes is usually the origin of the vibration of the elevator.

(5) Whether the mechanical vibrations-reduction rubber pads are employed in the elevator car or the traction motor is important as well.

The electrical related parameters also have effects on the comfort. Improper settings may cause vibration in the vertical direction.

(1) The motor related parameters 02-00 ~ 02-17 are the parameters mainly used by the system for controlling the motor. Incorrect motor type selection, incorrect parameter settings, or inaccurate self-learning results may cause motor's vibration or noise which in turn may affect the comfort.

Parameter	Name of the parameter	Default value	Parameter range
02-00	Motor Auto Tuning	0	0: No function 1: Rolling test 2: Static test
02-01	Full-load Current of Motor	###	(30 ~ 120%) * the model's rated current (Amps)
02-02	Rated power of Motor	###	0.00 ~ 655.35kW
02-03	Rated speed of Motor (rpm)	1710	0~65535
02-04	Number of Motor Poles	4	2~96
02-05	Angle between Magnetic Pole and PG Origin	360.0	0.0~360.0°
02-06	Output Direction Selection	0	0: Same as the configured direction 1: Opposite to the configured direction
02-07	Encoder type selection	0	0: No function 1: ABZ 2: ABZ + Hall 3: SIN/COS + Sinusoidal 4: SIN/COS + Endat 5: SIN/COS 6: SIN/COS + Hiperface
02-08	Encoder Pulse	600	1~25000
02-09	Encoder's input type setting	0	0: No function 1: Phases A/B are pulse inputs: Phase A is 90 degree leading Phase B with forward rotation 2: Phases A/B are pulse inputs: Phase B is 90 degree leading Phase A with forward rotation 3: Phase A is a pulse input; Phase B is the direction input: L is reverse direction and H is forward direction 4 : Phase A is a pulse input; Phase B is the direction input: L is forward direction and H is reverse direction 5: Single phase input

02-10	U, V, W input mode selection	0	0: Z signal is at the falling edge of Phase U 1: Z signal is at the leading edge of Phase U
02-11	Rated frequency of Motor	60.00/ 50.00	0.00 ~ 400.00Hz
02-12	Rated voltage of Motor	220.0 440.0	230V Series: 0.0V ~ 255.0V 460V Series: 0.0V ~ 510.0V
02-13	No-load current of Motor	###	0 ~ Motor's full load current (Parameter 02-01) setting
02-14	Stator Resistance (Rs) of Motor	0.000	0.000~65.535Ω
02-15	Rotor Resistance (Rr) of Motor	0.000	0.000~65.535Ω
02-16	Magnetizing Inductance (Lm) of Motor	0.0	0.0~6553.5mH
02-17	Stator Inductance (Lx) of Motor	0.0	0.0~6553.5mH

- (2) The parameters 06-03 and 06-04 are the acceleration times for the rapid acceleration at starting section S1 and the rapid acceleration at the ending section S2 of the S curve movement. If the times are too short, vibrations may occur at the corresponding sections. The acceleration time for S2 may be increased properly.

Parameter	Name of the parameter	Default value	Parameter range
06-03	S-curve for Acceleration Departure Time S1	1.00	0.00 ~ 25.00 seconds
06-04	S-curve for Acceleration Arrival Time S2	1.00	0.00 ~ 25.00 seconds

- (3) The parameters 06-05 and 06-06 are the deceleration times for the rapid deceleration at starting section S3 and the rapid deceleration at the ending section S4 of the S curve movement. If the times are too short, vibrations may occur at the corresponding sections. The deceleration time for S4 may be increased properly.

Parameter	Name of the parameter	Default value	Parameter range
06-05	S-curve for Deceleration Departure Time S3	2.50	0.30 ~ 4.00 seconds
06-06	S-curve for Deceleration Arrival Time S4	2.50	0.30 ~ 4.00 seconds

- (4) Adjustment at startup

Parameter	Name of the parameter	Default value	Parameter range
06-15	Brake Release Delay Time when Elevator Starts	0.250	0.000 ~ 65.000 seconds
06-17	Turn On Delay of Magnetic Contactor between Drive and Motor	0.200	0.000 ~ 65.000 seconds
06-18	Turn Off Delay of Magnetic Contactor between Drive and Motor	0.200	0.000 ~ 65.000 seconds
06-20	DC brake time at startup	0.0	0.0 ~ 60.0 seconds
07-01	Zero-speed bandwidth	10	0 ~ 40Hz
07-05	Zero-speed ASR P gain	100.0	0.0~500.0%
07-23	Operation Time of Zero Speed	0.250	0.000 ~ 65.535 seconds
07-24	Zero Speed Gain (P)	80.00	0~655.00%
07-25	Low-pass filtering time at the starting position	0.004	0.000 ~ 65.535 seconds

- ※ At startup, the elevator may exhibit distinct vibrations. Adjust the mechanical brake release delay time 06-15 and the opening time for the contracting brake. Meanwhile, it is necessary to adjust the DC actuation time at startup and the PI value at startup so as to prevent the elevator from sudden falling.

(5) Adjustment for ordinary movement

Parameter	Name of the parameter	Default value	Parameter range
06-01	Deceleration	0.50	0.00 ~ 2.00m/s ²
06-02	Forced deceleration	0.50	0.00 ~ 2.00m/s ²
06-04	S-curve for Acceleration Arrival Time S2	1.00	0.00 ~ 25.00 seconds
06-05	S-curve for Deceleration Departure Time S3	2.50	0.30 ~ 4.00 seconds
06-06	S-curve for Deceleration Arrival Time S4	2.50	0.30 ~ 4.00 seconds
06-07	Landing deceleration	10.00	0.00 ~ 20.00m/s ²
07-00	Inertia Ratio	40	1~300%
07-01	Zero-speed bandwidth	10	0 ~ 40Hz
07-02	Low-speed bandwidth	10	0 ~ 40Hz
07-03	High-speed bandwidth	10	0 ~ 40Hz
07-04	Zero-speed bandwidth at parking	10	0 ~ 40Hz
07-05	Zero-speed ASR P gain	100.0	0.0~500.0%
07-06	Zero-speed ASR integration time I	0.100	0.000 ~ 10.000 seconds
07-07	ASR P1 gain	100.0	0.0~500.0%
07-08	ASR integration time I1	0.100	0.000 ~ 10.000 seconds
07-09	ASR P2 gain	100.0	0.0~500.0%
07-10	ASR integration time I2	0.100	0.000 ~ 10.000 seconds

- ※ If a weightlessness feeling occurs during the elevator's movement, the acceleration/deceleration time can be increased properly; if the transition from low speed to high speed or from high speed to low speed seems too rush, the corresponding times in the S curve can be modified; if vibrations always occur during normal movement, the low-speed bandwidth, high-speed bandwidth, mechanical inertia percentage and corresponding PI can be adjusted.

(6) Adjustment at stop

Parameter	Name of the parameter	Default value	Parameter range
06-07	Landing deceleration	10.00	0.00 ~ 20.00m/s ²
06-21	DC brake time at stop	0.0	0.0 ~ 60.0 seconds
06-39	Distance margin for landing deceleration	100.0	0.0 ~ 6000.0mm
07-11	Zero-speed ASR P gain at landing	100.0	0.0~500.0%
07-12	Zero-speed ASR integration time I at landing	0.100	0.000 ~ 10.000 seconds
07-26	Direct landing position control P gain	10.00	0.0~655.00 %
07-27	Low pass filter time for direct landing position control	0.018	0 ~ 1.000 seconds

- ※ If vibrations occur at stop, in addition to the parameters listed above, the crawling speed and crawling distance can be adjusted as well (it is recommended that the leveling time shall not exceed 4 seconds).

(7) Leveling position correction

Parameter	Name of the parameter	Default value	Parameter range
04-00	Landing board length	0.0	0.0 ~ 999.9mm
04-01	Distance between upper and lower leveling signals	0.0	0.0 ~ 999.9mm

Landing board length 04-00: (mm) the value obtained from the self-learning process

Spacing between the upper and lower leveling signals 04-01: (mm) the value obtained from the self-learning process

- ※ Fine-tuning of these two parameters can correct the distance between the elevator's car and the leveling height.

4 Group Control

Basic Parameter

- ※ Related parameters setting for group control:

Parameter	Function of parameter	Default value	Range
08-08	Number of elevators for group control	1	1~8
08-09	Elevator No. in group control	1	1~8
08-10	Group control selection	0	b0=1 : Group control enable

- (1) The number of elevators for group control can be set in 08-08 ; 08-09 is to give serial number for the elevators in the group. The elevator is Master when 08-09 is set 1.

- ※ The numbers given to group controlled elevators must be continuous series. For example, four elevators are for group control, and their number must be 1, 2, 3, 4. If they are given 1, 3, 5, 7, then the group control can not be used.

- (2) Group control function will be enabled when 08-10 bit set as 1.

5 Summary of Parameters

00 Parameters for display

✈ The parameter can be set during operation

☑ represents that the parameter can be configured as show/hidden

Parameter code	Function of the parameter	Parameter range	level	Default value	VF	VFP	SVC	FOCPG	TQCPG	FOCPM
00-00	Speed command	Read only			○	○	○	○	○	○
00-01	Output speed	Read only			○	○	○	○	○	○
00-02	VBUS voltage	Read only			○	○	○	○	○	○
00-03	Output current	Read only			○	○	○	○	○	○
00-04	Output voltage	Read only			○	○	○	○	○	○
00-05	Power factor angle	Read only			○	○	○	○	○	○
00-06	Output power	Read only			○	○	○	○	○	○
00-07	Reserved									
00-08	Motor speed	Read only			○	○	○	○	○	○
00-09	Output torque	Read only			○	○	○	○	○	○
00-10	PG feedback	Read only			○	○	○	○	○	○
00-11	Display the IED output electrical angle	Read only			○	○	○	○	○	○
00-12	AVI(%)	Read only			○	○	○	○	○	○
00-13	Rectifier/power capacitor temperature	Read only			○	○	○	○	○	○
00-14	Power module IGBT temperature	Read only			○	○	○	○	○	○
00-15	Status of IED input terminals MI1~MI16	Read only			○	○	○	○	○	○
00-16	Status of IED input terminals MI17~MI24	Read only			○	○	○	○	○	○
00-17	Status of IED input terminals MI26~MI36	Read only			○	○	○	○	○	○
00-18	Status of IED output terminals RY1~RY16	Read only			○	○	○	○	○	○
00-19	Multi-stage speed status	0 : Zero speed 1 : Reserved 2 : Hoistway self-learned speed 3 : Inspection speed 4 : Reverse leveling speed 5 : Fast car speed 6 : Rescue speed			○	○	○	○	○	○
00-20	IED driving status	b5: Hidden the parameter display b10: Command source b11: Parameter lock display Others: Reserved			○	○	○	○	○	○
00-21	IED internal error code	Read only			○	○	○	○	○	○
00-22	IED warning code	Read only			○	○	○	○	○	○
00-23	Car status 1	b0: Up-going b1: Down-going b2: Landing b3: Stop b4: Front door open b5: Front door close b6: Overload b7: Error occurs			○	○	○	○	○	○

Parameter code	Function of the parameter	Parameter range	level	Default value	VF	VFPG	SVC	FOCPG	TQCPCG	FOCPM
		b8: Reserved b9: Reserved b10: Reserved b11: Front door opening delay b12: Light output display b13: Fan output display b14: Buzzer output display b15: Reserved								
00-24	Car status 2	b0: Inspection up-going b1: Inspection down-going b2: Front door close display b3: Reserved b4: Reserved b5: Reserved b6: Full load b7: Door lock bypass feedback b8: Reserved b9: Reserved b10: Reserved b11: Reserved b12: Rear door open b13: Rear door close b14: Rear door opening delay b15: Reserved			○	○	○	○	○	○
00-25	Operation mode	b0: Normal mode b1: Inspection mode b2: Elevator lock mode b3: Error occurs b4: Operator mode b5: VIP mode b6: Fire emergency landing mode b7: (1 st level) Fire rescue mode b8: Twins control mode b9: Group control mode b10: Hoistway self-learning mode b11: Re-positioning b12: Leveling finding b13: Independent mode b14: Elevator jogging b15: Emergency power mode			○	○	○	○	○	○
00-26	Elevator door status	b0: Front door open output display b1: Front door close output display b2: Front door motor reset display b3: Front door slow operation output display b4: Rear door open output display b5: Rear door close output display b6: Rear door motor reset display b7: Rear door slow operation output display b8: Front door open limit b9: Front door close limit b10: Front door light curtain b11: Reserved b12: Rear door open limit b13: Rear door close limit b14: Rear door light curtain b15: Reserved			○	○	○	○	○	○
00-27	In-car display board floor command 1 (Floor 1 ~ 16)	Read only			○	○	○	○	○	○

Elevator Commissioning Guide

Parameter code	Function of the parameter	Parameter range	level	Default value	VF	VFP	SVC	FOCP	TQCP	FOCPM
00-28	In-car display board floor command 2 (Floor 17 ~ 32)	Read only			○	○	○	○	○	○
00-29	In-car display board floor command 3 (Floor 33 ~ 48)	Read only			○	○	○	○	○	○
00-30	In-car display board floor display 1 (Floor 1 ~ 16)	Read only			○	○	○	○	○	○
00-31	In-car display board floor display 2 (Floor 17 ~ 32)	Read only			○	○	○	○	○	○
00-32	In-car display board floor display 3 (Floor 33 ~ 48)	Read only			○	○	○	○	○	○
00-33	In-car display board up-going command 1 (Floor 1 ~ 16)	Read only			○	○	○	○	○	○
00-34	In-car display board up-going command 2 (Floor 17 ~ 32)	Read only			○	○	○	○	○	○
00-35	In-car display board up-going command 3 (Floor 33 ~ 48)	Read only			○	○	○	○	○	○
00-36	External display board up-going display 1 (Floor 1 ~ 16)	Read only			○	○	○	○	○	○
00-37	External display board up-going display 2 (Floor 17 ~ 32)	Read only			○	○	○	○	○	○
00-38	External display board up-going display 3 (Floor 33 ~ 48)	Read only			○	○	○	○	○	○
00-39	In-car display board down-going command 1 (Floor 1 ~ 16)	Read only			○	○	○	○	○	○
00-40	In-car display board down-going command 2 (Floor 17 ~ 32)	Read only			○	○	○	○	○	○
00-41	In-car display board down-going command 3 (Floor 33 ~ 48)	Read only			○	○	○	○	○	○
00-42	External display board down-going display 1 (Floor 1 ~ 16)	Read only			○	○	○	○	○	○
00-43	External display board down-going display 2 (Floor 17 ~ 32)	Read only			○	○	○	○	○	○
00-44	External display board down-going display 3 (Floor 33 ~ 48)	Read only			○	○	○	○	○	○
00-45	Current floor	Read only			○	○	○	○	○	○
00-46	Current position (0.1mm)	Read only			○	○	○	○	○	○
00-47	Current position (1m)	Read only			○	○	○	○	○	○
00-48	Elevator error code	Read only			○	○	○	○	○	○
00-49	Weighting compensation input value	Read only			○	○	○	○	○	○
00-50	Car-top board input terminal MI1~MI8 status	Read only			○	○	○	○	○	○
00-51	Car-top board input terminal RY1~RY8 status	Read only			○	○	○	○	○	○
00-52	Number of operations (in ten thousands)	Read only			○	○	○	○	○	○
00-53	Number of operations (times)	Read only			○	○	○	○	○	○
00-54	External display board communication status 1 (Floor 1 ~ 16)	Read only			○	○	○	○	○	○
00-55	External display board communication status 2 (Floor 17 ~ 32)	Read only			○	○	○	○	○	○
00-56	External display board	Read only			○	○	○	○	○	○

Parameter code	Function of the parameter	Parameter range	level	Default value	VF	VFP	SVC	FOCPG	TQCPG	FOCPM
	communication status 3 (Floor 33 ~ 48)									
00-57	PGHS card error code	Read only			o	o	o	o	o	o
00-58	Direction + the most distant floor	Read only			o	o	o	o	o	o
00-59	Target floor	Read only			o	o	o	o	o	o
00-60	First error record	Read only			o	o	o	o	o	o
00-61	First error time (minute)	Read only			o	o	o	o	o	o
00-62	First error time (days)	Read only			o	o	o	o	o	o
00-63	Display the speed command on error	Read only			o	o	o	o	o	o
00-64	Display the output voltage on error	Read only			o	o	o	o	o	o
00-65	Display the VBUS voltage on error	Read only			o	o	o	o	o	o
00-66	Display output speed on error	Read only			o	o	o	o	o	o
00-67	Display the output current on error	Read only			o	o	o	o	o	o
00-68	Display the motor speed on error	Read only			o	o	o	o	o	o
00-69	Display the output power on error	Read only			o	o	o	o	o	o
00-70	Display output torque on error	Read only			o	o	o	o	o	o
00-71	Display the multi-function input terminal MI1~MI8 status on error	Read only			o	o	o	o	o	o
00-72	Display the multi-function input terminal MI9~MI22 status on error	Read only			o	o	o	o	o	o
00-73	Reserved									
00-74	Display the multi-function terminal RY1 ~ RY16 status on error	Read only			o	o	o	o	o	o
00-75	Display the driving status of IED operation fault	Read only			o	o	o	o	o	o
00-76	Second error record	Read only			o	o	o	o	o	o
00-77	Second error time (minute)	Read only			o	o	o	o	o	o
00-78	Second error time (days)	Read only			o	o	o	o	o	o
00-79	Third error record	Read only			o	o	o	o	o	o
00-80	Third error time (minute)	Read only			o	o	o	o	o	o
00-81	Third error time (days)	Read only			o	o	o	o	o	o
00-82	Fourth error record	Read only			o	o	o	o	o	o
00-83	Fourth error time (minute)	Read only			o	o	o	o	o	o
00-84	Fourth error time (days)	Read only			o	o	o	o	o	o
00-85	Fifth error record	Read only			o	o	o	o	o	o
00-86	Fifth error time (minute)	Read only			o	o	o	o	o	o
00-87	Fifth error time (days)	Read only			o	o	o	o	o	o
00-88	Sixth error record	Read only			o	o	o	o	o	o
00-89	Sixth error time (minute)	Read only			o	o	o	o	o	o
00-90	Sixth error time (days)	Read only			o	o	o	o	o	o
00-91	Data display	Read only			o	o	o	o	o	o
00-92	Display motor continuous running time (minutes)	Read only			o	o	o	o	o	o
00-93	Display motor continuous running time (days)	Read only			o	o	o	o	o	o
00-94	Rated current	Read only			o	o	o	o	o	o
00-95	Firmware version	Read only			o	o	o	o	o	o

01 System Parameters

✎ The parameter can be set during operation

☑ represents that the parameter can be configured as show/hidden

Parameter code	Function of the parameter	Parameter range	level	Default value	VF	VFPG	SVC	FOCPG	TQCPG	FOCPM
01-00	Identity code of IED	8: 230V, 3HP 10 : 230V, 5HP 11 : 460 V, 5HP (4.0kW) 12 : 230V, 7.5HP 13 : 460 V, 7.5HP 14 : 230V, 10HP 15 : 460V, 10HP 16 : 230V, 15HP 17 : 460V, 15HP 18 : 230V, 20HP 19 : 460V, 20HP 20 : 230V, 25HP 21 : 460V, 25HP 22 : 230V, 30HP 23 : 460V, 30HP 24 : 230V, 40HP 25 : 460V, 40HP 26 : 230V, 50HP 27 : 460V, 50HP 29 : 460V, 60HP 31 : 460V, 75HP 33 : 460V, 100HP		Read only	○	○	○	○	○	○
01-01	Parameter management setting	0: No function 1: Parameter write proof 3: Show the hidden parameter(☑) 8: Panel operation is disabled 9: Parameter reset (Base frequency is 50Hz) 10: Parameter reset (Base frequency is 60Hz)		0	○	○	○	○	○	○
01-02	Control method	0: V/F control 1: V/F control + Encoder (VFPG) 2: Sensorless vector control (SVC) 3: FOC vector control + Encoder (FOCPG) 4: Torque control + Encoder (TQCPG) 8: FOC PM control (FOCPM)		0	○	○	○	○	○	○
01-03	System control	bit 0=0: No function bit 0=1: ASR automatic adjustment, PDFF enable bit 7=0: No function bit 7=1: Startup position control is enabled bit 10=0: No function bit 10 = 1: Direct parking is enabled bit 15=0: No function bit 15=1: Magnetic pole detection is disabled when power on		0x0481h				○		○
✎ 01-04	Elevator speed	0.10 ~ 4.00 m/s		1.00				○		○
01-05	Maximum Operation Frequency	10.00 ~ 400.00Hz		60.00/ 50.00	○	○	○	○	○	○
✎ 01-06	Parameter protection unlock password input	1~9998 , 10000~65535 0~2: Record the times of error passwords input		0	○	○	○	○	○	○
✎ 01-07	Parameter protection password setting	1~9998 , 10000~65535 0: Password is not set or input correct password (01-06)	☑	0	○	○	○	○	○	○

Parameter code	Function of the parameter	Parameter range	level	Default value	VF	VFPF	SVC	FOCPG	TQCPG	FOCPM
		1: Parameters have been locked								
↗ 01-08	Carrier Frequency	2 ~ 15KHz	<input checked="" type="checkbox"/>	12	<input type="radio"/>	<input type="radio"/>	<input type="radio"/>	<input type="radio"/>	<input type="radio"/>	<input type="radio"/>
↗ 01-09	Automatic Voltage Rectifying (AVR) function	0: Enable AVR 1: Disable AVR 2: Disable AVR during parking deceleration	<input checked="" type="checkbox"/>	0	<input type="radio"/>	<input type="radio"/>	<input type="radio"/>	<input type="radio"/>	<input type="radio"/>	<input type="radio"/>
↗ 01-10	Fan control	0: Fan always ON 1: 1 minute after AC motor drive stops, fan will be OFF 2: AC motor drive runs and fan ON, AC motor drive stops and fan OFF 3: Fan ON to run when preliminary heat sink temperature attained 4: Fan always OFF	<input checked="" type="checkbox"/>	2	<input type="radio"/>	<input type="radio"/>	<input type="radio"/>	<input type="radio"/>	<input type="radio"/>	<input type="radio"/>
↗ 01-11	Elevator acceleration	0.20 ~ 2.00m/s ²	<input checked="" type="checkbox"/>	0.75	<input type="radio"/>	<input type="radio"/>	<input type="radio"/>	<input type="radio"/>	<input type="radio"/>	<input type="radio"/>
↗ 01-12	Motor current at Accel.	50~200%	<input checked="" type="checkbox"/>	150	<input type="radio"/>	<input type="radio"/>	<input type="radio"/>	<input type="radio"/>	<input type="radio"/>	<input type="radio"/>
↗ 01-13	Monitoring data address	0~FFFF	<input checked="" type="checkbox"/>	0	<input type="radio"/>	<input type="radio"/>	<input type="radio"/>	<input type="radio"/>	<input type="radio"/>	<input type="radio"/>
↗ 01-14	Real time clock (RTM_HOURMIN)	00~2359	<input checked="" type="checkbox"/>	0	<input type="radio"/>	<input type="radio"/>	<input type="radio"/>	<input type="radio"/>	<input type="radio"/>	<input type="radio"/>
↗ 01-15	Real time clock (RTM_WEEK)	0~6	<input checked="" type="checkbox"/>	0	<input type="radio"/>	<input type="radio"/>	<input type="radio"/>	<input type="radio"/>	<input type="radio"/>	<input type="radio"/>
↗ 01-16	Real time clock (RTM_MONDAY)	101~1231	<input checked="" type="checkbox"/>	101	<input type="radio"/>	<input type="radio"/>	<input type="radio"/>	<input type="radio"/>	<input type="radio"/>	<input type="radio"/>
↗ 01-17	Real time clock (RTM_YEAR)	0~99	<input checked="" type="checkbox"/>	0	<input type="radio"/>	<input type="radio"/>	<input type="radio"/>	<input type="radio"/>	<input type="radio"/>	<input type="radio"/>

02 Motor Parameters

✎ : The parameter can be set during operation

☑ represents that the parameter can be configured as show/hidden

Parameter code	Function of the parameter	Parameter range	level	Default value	VF	VFPF	SVC	FOCPG	TQCPG	FOCPM
02-00	Motor Auto Tuning	0: No function 1: Rolling test 2: Static test		0			○	○	○	○
02-01	Full-load Current of Motor	(30 ~ 120%) * the model's rated current (Amps)		###	○	○	○	○	○	○
02-02	Rated power of Motor	0.00 ~ 655.35kW		###			○	○	○	○
02-03	Rated speed of Motor (rpm)	0~65535		1710		○	○	○	○	○
02-04	Number of Motor Poles	2~96		4	○	○	○	○	○	○
02-05	Angle between Magnetic Pole and PG Origin	0.0~360.0°		360.0						○
02-06	Output Direction Selection	0: Same as the configured direction 1: Opposite to the configured direction		0	○	○	○	○	○	○
02-07	Encoder type selection	0: No function 1: ABZ 2: ABZ + Hall 3: SIN/COS + Sinusoidal 4: SIN/COS + Endat 5: SIN/COS 6: SIN/COS + Hiperface		0		○		○	○	○
02-08	Encoder Pulse	1~25000		600		○		○	○	○
02-09	Encoder's input type setting	0: No function 1: Phases A/B are pulse inputs: Phase A is 90 degree leading Phase B with forward rotation 2: Phases A/B are pulse inputs: Phase B is 90 degree leading Phase A with forward rotation 3: Phase A is a pulse input; Phase B is the direction input: L is reverse direction and H is forward direction 4 : Phase A is a pulse input; Phase B is the direction input: L is forward direction and H is reverse direction 5: Single phase input		0		○		○	○	○
02-10	U, V, W input mode selection	0: Z signal is at the falling edge of Phase U 1: Z signal is at the leading edge of Phase U		0		○		○	○	○
02-11	Rated frequency of Motor	0.00 ~ 400.00Hz		60.00/ 50.00	○	○	○	○	○	○
02-12	Rated voltage of Motor	230V Series: 0.0V ~ 255.0V 460V Series: 0.0V ~ 510.0V		220.0 440.0	○	○	○	○	○	○
02-13	No-load current of Motor	0 ~ Motor's full load current (Parameter 02-01) setting	☑	###		○	○	○	○	
02-14	Stator Resistance (Rs) of Motor	0.000~65.535Ω	☑	0.000			○	○	○	

Parameter code	Function of the parameter	Parameter range	level	Default value	VF	VFPF	SVC	FOCPG	TQCPG	FOCPM
02-15	Rotor Resistance (Rr) of Motor	0.000~65.535Ω	<input checked="" type="checkbox"/>	0.000			○	○	○	
02-16	Magnetizing Inductance (Lm) of Motor	0.0~6553.5mH	<input checked="" type="checkbox"/>	0.0			○	○	○	
02-17	Stator Inductance (Lx) of Motor	0.0~6553.5mH	<input checked="" type="checkbox"/>	0.0			○	○	○	
02-18	Back Electromotive Force	0.0~6553.5Vrms	<input checked="" type="checkbox"/>	0.0						○
02-19	Magnetic Pole Re-positioning	0: Reserved 1: Reconfigure the magnetic positioning 2: Reserved	<input checked="" type="checkbox"/>	0						○
↗ 02-20	Torque Compensation Time Constant	0.001 ~ 10.000 seconds	<input checked="" type="checkbox"/>	0.020			○			
↗ 02-21	Slip Compensation Time Constant	0.001 ~ 10.000 seconds	<input checked="" type="checkbox"/>	0.100			○			
↗ 02-22	Torque Compensation Gain	0~10	<input checked="" type="checkbox"/>	0	○	○				
↗ 02-23	Slip Compensation Gain	0.00~10.00	<input checked="" type="checkbox"/>	0.00	○	○	○			
↗ 02-24	Slip Deviation Level	0~1000% (0: not detecting)	<input checked="" type="checkbox"/>	0		○	○	○		
↗ 02-25	Detection Time of Slip Deviation	0.0 ~ 10.0 seconds	<input checked="" type="checkbox"/>	1.0		○	○	○		
↗ 02-26	Over Slip Treatment	0: Warn and keep operation 1: Warn and ramp to stop 2: Warn and coast to stop	<input checked="" type="checkbox"/>	0		○	○	○		
↗ 02-27	Hunting Gain	0~10000 (0: not activated)	<input checked="" type="checkbox"/>	2000	○	○	○			
02-28	Accumulative Motor Operation Time (Min.)	00~1439	<input checked="" type="checkbox"/>	00	○	○	○	○	○	○
02-29	Accumulative Drive Power on Time (day)	00~65535	<input checked="" type="checkbox"/>	00	○	○	○	○	○	○
02-30	2 nd Output Frequency Setting 1	0.00 ~ 400.00Hz	<input checked="" type="checkbox"/>	0.50	○	○				
↗ 02-31	2 nd Output Voltage Setting 1	230V Series: 0.0V ~ 255.0V 460V Series: 0.0V ~ 510.0V	<input checked="" type="checkbox"/>	5.0 10.0	○	○				
02-32	3 rd Output Frequency Setting 1	0.00 ~ 400.00Hz	<input checked="" type="checkbox"/>	0.50	○	○				
↗ 02-33	3 rd Output Voltage Setting 1	230V Series: 0.0V ~ 255.0V 460V Series: 0.0V ~ 510.0V	<input checked="" type="checkbox"/>	5.0 10.0	○	○				
02-34	4 th Output Frequency Setting 1	0.00 ~ 400.00Hz	<input checked="" type="checkbox"/>	0.00	○	○	○	○	○	
↗ 02-35	4 th Output Voltage Setting 1	230V Series: 0.0V ~ 255.0V 460V Series: 0.0V ~ 510.0V	<input checked="" type="checkbox"/>	0.0 0.0	○	○				
02-36	Start Frequency	0.00 ~ 400.00Hz	<input checked="" type="checkbox"/>	0.00	○	○	○	○		

03 Multi-function Output/Input Function Parameters

✎ The parameter can be set during operation

☑ represents that the parameter can be configured as show/hidden

Parameter code	Function of the parameter	Parameter range	level	Default value	VF	VFPG	SVC	FOCPG	TQCPG	FOCPM
03-00	Multi-function input command 1 (MI1)	0: No function (Normal Open)		101	○	○	○	○	○	○
03-01	Multi-function input command 2 (MI2)	1: Inspection signal (Normal Open)		2	○	○	○	○	○	○
03-02	Multi-function input command 3 (MI3)	2: Inspection up-going (Normal Open)		3					○	
03-03	Multi-function input command 4 (MI4)	3: Inspection down-going (Normal Open)		4	○	○	○	○	○	○
03-04	Multi-function input command 5 (MI5)	4: Upper leveling signal (Normal Open)		5	○	○	○	○	○	○
03-05	Multi-function input command 6 (MI6)	5: Lower leveling signal (Normal Open)		6	○	○	○	○	○	○
03-06	Multi-function input command 7 (MI7)	6: Door position input (Normal Open)		7	○	○	○	○	○	○
03-07	Multi-function input command 8 (MI8)	7: Door inter-lock circuit feedback (Normal Open)		8	○	○	○	○	○	○
03-08	Multi-function input command 9 (MI9)	8: Brake circuit feedback (Normal Open)		9	○	○	○	○	○	○
03-09	Multi-function input command 10 (MI10)	9: Operation output feedback (Normal Open)		101	○	○	○	○	○	○
03-10	Multi-function input command 11 (MI11)	10: Safety circuit feedback (Normal Open)		111	○	○	○	○	○	○
03-11	Multi-function input command 12 (MI12)	11: Up-most limit signal (Normal Open)		112	○	○	○	○	○	○
03-12	Multi-function input command 13 (MI13)	12: Upward 1 st level forced deceleration (Normal Open)		113	○	○	○	○	○	○
03-13	Multi-function input command 14 (MI14)	13: Upward 2 nd level forced deceleration (Normal Open)		114	○	○	○	○	○	○
03-14	Multi-function input command 15 (MI15)	14: Upward 3 rd level forced deceleration (Normal Open)		115	○	○	○	○	○	○
03-15	Multi-function input command 16 (MI16)	15: Down-most limit signal (Normal Open)		116	○	○	○	○	○	○
03-16	Multi-function input command 17 (MI17)	16: Downward 1 st level forced deceleration (Normal Open)		117	○	○	○	○	○	○
03-17	Multi-function input command 18 (MI18)	17: Downward 2 nd level forced deceleration (Normal Open)		118	○	○	○	○	○	○
03-18	Multi-function input command 19 (MI19)	18: Downward 3rd level forced deceleration (Normal Open)		0	○	○	○	○	○	○
03-19	Multi-function input command 20 (MI20)	19: Door pre-opening output feedback (Normal Open)		0	○	○	○	○	○	○
03-20	Multi-function input command 21 (MI21)	20: Safety circuit feedback 2 (Normal Open)		0	○	○	○	○	○	○
03-21	Multi-function input command 22 (MI22)	21: Brake close feedback 2 (Normal Open)		0	○	○	○	○	○	○
03-22	Multi-function input command 23 (MI23)	22: Door close circuit feedback 2 (Normal Open)		0	○	○	○	○	○	○
03-23	Multi-function input command 24 (MI24)	23: Overload input (Normal Open)		0	○	○	○	○	○	○
03-24	Extension Multi-function input command 1 (XI1)	24: Full-load input (Normal Open)		0	○	○	○	○	○	○

Parameter code	Function of the parameter	Parameter range	level	Default value	VF	VFPG	SVC	FOCPG	TQCPG	FOCPM
03-25	Extension Multi-function input command 2 (XI2)	25: Fire signal (Normal Open)		0	○	○	○	○	○	○
03-26	Extension Multi-function input command 3 (XI3)	26: Fire mode (Normal Open)		0	○	○	○	○	○	○
03-27	Extension Multi-function input command 4 (XI4)	27: Light curtain signal 1 (Normal Open)		0	○	○	○	○	○	○
03-28	Extension Multi-function input command 5 (XI5)	28: Light curtain signal 2 (Normal Open)		0	○	○	○	○	○	○
03-29	Extension Multi-function input command 6 (XI6)	29: Elevator lock signal (Normal Open)		0	○	○	○	○	○	○
03-30	Extension Multi-function input command 7 (XI7)	30: Emergency power supply feedback (Normal Open)		0	○	○	○	○	○	○
03-31	Extension Multi-function input command 8 (XI8)	101: Inspection signal (Normal Close)		0	○	○	○	○	○	○
03-32	Extension Multi-function input command 9 (XI9)	102: Inspection up-going (Normal Close)		0	○	○	○	○	○	○
03-33	Extension Multi-function input command 10 (XI10)	103: Inspection down-going (Normal Close)		0	○	○	○	○	○	○
03-34	Extension Multi-function input command 11 (XI11)	104: Upper leveling signal (Normal Close)		0	○	○	○	○	○	○
03-35	Extension Multi-function input command 12 (XI12)	105: Lower leveling signal (Normal Close)		0	○	○	○	○	○	○
		106: Door position input (Normal Close)								
		107: Door inter-lock circuit feedback (Normal Close)								
		108: Brake circuit feedback (Normal Close)								
		109: Operation output feedback (Normal Close)								
		110: Safety circuit feedback (Normal Close)								
		111: Up-most limit signal (Normal Close)								
		112: Upward 1 st level forced deceleration (Normal Close)								
		113: Upward 2 nd level forced deceleration (Normal Close)								
		114: Upward 3 rd level forced deceleration (Normal Close)								
		115: Down-most limit signal (Normal Close)								
		116: Downward 1 st level forced deceleration (Normal Close)								
		117: Downward 2 nd level forced deceleration (Normal Close)								
		118: Downward 3rd level forced deceleration (Normal Close)								
		119: Door pre-opening output feedback (Normal Close)								
		120: Safety circuit feedback 2 (Normal Close)								
		121: Brake close feedback 2 (Normal Close)								
		122: Door close circuit feedback 2 (Normal Close)								
		123: Overload input (Normal Close)								
		124: Full-load input (Normal Close)								
125: Fire signal (Normal Close)										
126: Fire mode (Normal Close)										
127: Light curtain signal 1 (Normal Close)										
128: Light curtain signal 2 (Normal Close)										
129: Elevator lock signal (Normal Close)										

Elevator Commissioning Guide

Parameter code	Function of the parameter	Parameter range	level	Default value	VF	VFP	SVC	FOCPG	TQCPG	FOCPM
		130: Emergency power supply feedback (Normal Close)								
03-36	Digital input direction 1	0~65535		0	o	o	o	o	o	o
03-37	Digital input direction 2	0~65535		0	o	o	o	o	o	o
03-38	Digital input direction 3	0~65535		0	o	o	o	o	o	o
03-39	Digital input response time	0.001 ~ 30.000 seconds		0.005	o	o	o	o	o	o
03-40	Multi-function output Relay 1 (RA)	0: No function		1	o	o	o	o	o	o
03-41	Multi-function output Relay 2 (MRA)	1: Motor's solenoid valve control output		2	o	o	o	o	o	o
03-42	Multi-function output Relay 3 (R1A)	2: Mechanical brake release		3	o	o	o	o	o	o
03-43	Multi-function output Relay 4 (R2A)	3: Mechanical brake enhanced release		0	o	o	o	o	o	o
03-44	Multi-function output Relay 5 (R3A)	4: Mechanical brake, electromagnetic contactor normal		0	o	o	o	o	o	o
03-45	Multi-function output Relay 6 (R4A)	5: Fault output		0	o	o	o	o	o	o
03-46	Multi-function output Relay 7 (R5A)	6: Operation monitoring		0	o	o	o	o	o	o
03-47	Multi-function output Relay 8 (R6A)	7: Group control ready		0	o	o	o	o	o	o
03-48	Multi-function output Relay 9	8: Door pre-opening contactor output		0	o	o	o	o	o	o
03-49	Multi-function output Relay 10	9: Door motor 1 open		0	o	o	o	o	o	o
03-50	Multi-function output Relay 11	10: Door motor 1 close		0	o	o	o	o	o	o
03-51	Multi-function output Relay 12	11: Door motor 2 open		0	o	o	o	o	o	o
03-52	Multi-function output Relay 13	12: Door motor 2 close		0	o	o	o	o	o	o
03-53	Multi-function output Relay 14	13: Door inter-lock circuit output		0	o	o	o	o	o	o
03-54	Multi-function output Relay 15	14: Emergency power output		0	o	o	o	o	o	o
03-55	Multi-function output Relay 16	15: PM motor three-phase short circuit output		0	o	o	o	o	o	o
03-56	Digital output direction	0~65535		0	o	o	o	o	o	o
03-57	AUI1 analog input function selection	0: No function 1: Preload input 2: PTC thermistor input 3~10: reserved		1	o	o	o	o	o	o
03-58	AUI1 analog input bias	-100.0~100.0%		0.0	o	o	o	o	o	o
03-59	AUI1 analog input gain	-500.0~500.0%		100.0	o	o	o	o	o	o
03-60	Torque Offset Selection (TOROFSE)	0: No weighting signal 1: Signal from Analog input 2: Signal from Car-top board input 3: Reserved		0			o	o	o	o

04 Floor Position Parameters

✎ The parameter can be set during operation

☑ represents that the parameter can be configured as show/hidden

Parameter code	Function of the parameter	Parameter range	level	Default value	VF	VFP	SVC	FOCPG	TQCPG	FOCPM
04-00	Landing board length	0.0 ~ 999.9mm		0.0	☐	☐	☐	☐		☐
04-01	Distance between upper and lower leveling signals	0.0 ~ 999.9mm		0.0	☐	☐	☐	☐		☐
04-02	Floor 1 position - high	0 ~ 9999m		0	☐	☐	☐	☐		☐
04-03	Floor 1 position - low	0.0 ~ 999.9mm		0.0	☐	☐	☐	☐		☐
04-04	Floor 2 position - high	0 ~ 9999m		0	☐	☐	☐	☐		☐
04-05	Floor 2 position - low	0.0 ~ 999.9mm		0.0	☐	☐	☐	☐		☐
04-06	Floor 3 position - high	0 ~ 9999m		0	☐	☐	☐	☐		☐
04-07	Floor 3 position - low	0.0 ~ 999.9mm		0.0	☐	☐	☐	☐		☐
04-08	Floor 4 position - high	0 ~ 9999m		0	☐	☐	☐	☐		☐
04-09	Floor 4 position - low	0.0 ~ 999.9mm		0.0	☐	☐	☐	☐		☐
04-10	Floor 5 position - high	0 ~ 9999m		0	☐	☐	☐	☐		☐
04-11	Floor 5 position - low	0.0 ~ 999.9mm		0.0	☐	☐	☐	☐		☐
04-12	Floor 6 position - high	0 ~ 9999m		0	☐	☐	☐	☐		☐
04-13	Floor 6 position - low	0.0 ~ 999.9mm		0.0	☐	☐	☐	☐		☐
04-14	Floor 7 position - high	0 ~ 9999m		0	☐	☐	☐	☐		☐
04-15	Floor 7 position - low	0.0 ~ 999.9mm		0.0	☐	☐	☐	☐		☐
04-16	Floor 8 position - high	0 ~ 9999m		0	☐	☐	☐	☐		☐
04-17	Floor 8 position - low	0.0 ~ 999.9mm		0.0	☐	☐	☐	☐		☐
04-18	Floor 9 position - high	0 ~ 9999m		0	☐	☐	☐	☐		☐
04-19	Floor 9 position - low	0.0 ~ 999.9mm		0.0	☐	☐	☐	☐		☐
04-20	Floor 10 position - high	0 ~ 9999m		0	☐	☐	☐	☐		☐
04-21	Floor 10 position - low	0.0 ~ 999.9mm		0.0	☐	☐	☐	☐		☐
04-22	Floor 11 position - high	0 ~ 9999m		0	☐	☐	☐	☐		☐
04-23	Floor 11 position - low	0.0 ~ 999.9mm		0.0	☐	☐	☐	☐		☐
04-24	Floor 12 position - high	0 ~ 9999m		0	☐	☐	☐	☐		☐
04-25	Floor 12 position - low	0.0 ~ 999.9mm		0.0	☐	☐	☐	☐		☐
04-26	Floor 13 position - high	0 ~ 9999m		0	☐	☐	☐	☐		☐
04-27	Floor 13 position - low	0.0 ~ 999.9mm		0.0	☐	☐	☐	☐		☐
04-28	Floor 14 position - high	0 ~ 9999m		0	☐	☐	☐	☐		☐
04-29	Floor 14 position - low	0.0 ~ 999.9mm		0.0	☐	☐	☐	☐		☐
04-30	Floor 15 position - high	0 ~ 9999m		0	☐	☐	☐	☐		☐
04-31	Floor 15 position - low	0.0 ~ 999.9mm		0.0	☐	☐	☐	☐		☐
04-32	Floor 16 position - high	0 ~ 9999m		0	☐	☐	☐	☐		☐
04-33	Floor 16 position - low	0.0 ~ 999.9mm		0.0	☐	☐	☐	☐		☐
04-34	Floor 17 position - high	0 ~ 9999m		0	☐	☐	☐	☐		☐
04-35	Floor 17 position - low	0.0 ~ 999.9mm		0.0	☐	☐	☐	☐		☐
04-36	Floor 18 position - high	0 ~ 9999m		0	☐	☐	☐	☐		☐
04-37	Floor 18 position - low	0.0 ~ 999.9mm		0.0	☐	☐	☐	☐		☐
04-38	Floor 19 position - high	0 ~ 9999m		0	☐	☐	☐	☐		☐
04-39	Floor 19 position - low	0.0 ~ 999.9mm		0.0	☐	☐	☐	☐		☐
04-40	Floor 20 position - high	0 ~ 9999m		0	☐	☐	☐	☐		☐
04-41	Floor 20 position - low	0.0 ~ 999.9mm		0.0	☐	☐	☐	☐		☐
04-42	Floor 21 position - high	0 ~ 9999m		0	☐	☐	☐	☐		☐
04-43	Floor 21 position - low	0.0 ~ 999.9mm		0.0	☐	☐	☐	☐		☐
04-44	Floor 22 position - high	0 ~ 9999m		0	☐	☐	☐	☐		☐
04-45	Floor 22 position - low	0.0 ~ 999.9mm		0.0	☐	☐	☐	☐		☐
04-46	Floor 23 position - high	0 ~ 9999m		0	☐	☐	☐	☐		☐
04-47	Floor 23 position - low	0.0 ~ 999.9mm		0.0	☐	☐	☐	☐		☐

Elevator Commissioning Guide

Parameter code	Function of the parameter	Parameter range	level	Default value	VF	VFPG	SVC	FOCPG	TQCPG	FOCPM
04-48	Floor 24 position - high	0 ~ 9999m		0	o	o	o	o		o
04-49	Floor 24 position - low	0.0 ~ 999.9mm		0.0	o	o	o	o		o
04-50	Floor 25 position - high	0 ~ 9999m		0	o	o	o	o		o
04-51	Floor 25 position - low	0.0 ~ 999.9mm		0.0	o	o	o	o		o
04-52	Floor 26 position - high	0 ~ 9999m		0	o	o	o	o		o
04-53	Floor 26 position - low	0.0 ~ 999.9mm		0.0	o	o	o	o		o
04-54	Floor 27 position - high	0 ~ 9999m		0	o	o	o	o		o
04-55	Floor 27 position - low	0.0 ~ 999.9mm		0.0	o	o	o	o		o
04-56	Floor 28 position - high	0 ~ 9999m		0	o	o	o	o		o
04-57	Floor 28 position - low	0.0 ~ 999.9mm		0.0	o	o	o	o		o
04-58	Floor 29 position - high	0 ~ 9999m		0	o	o	o	o		o
04-59	Floor 29 position - low	0.0 ~ 999.9mm		0.0	o	o	o	o		o
04-60	Floor 30 position - high	0 ~ 9999m		0	o	o	o	o		o
04-61	Floor 30 position - low	0.0 ~ 999.9mm		0.0	o	o	o	o		o
04-62	Floor 31 position - high	0 ~ 9999m		0	o	o	o	o		o
04-63	Floor 31 position - low	0.0 ~ 999.9mm		0.0	o	o	o	o		o
04-64	Floor 32 position - high	0 ~ 9999m		0	o	o	o	o		o
04-65	Floor 32 position - low	0.0 ~ 999.9mm		0.0	o	o	o	o		o
04-66	Floor 33 position - high	0 ~ 9999m		0	o	o	o	o		o
04-67	Floor 33 position - low	0.0 ~ 999.9mm		0.0	o	o	o	o		o
04-68	Floor 34 position - high	0 ~ 9999m		0	o	o	o	o		o
04-69	Floor 34 position - low	0.0 ~ 999.9mm		0.0	o	o	o	o		o
04-70	Floor 35 position - high	0 ~ 9999m		0	o	o	o	o		o
04-71	Floor 35 position - low	0.0 ~ 999.9mm		0.0	o	o	o	o		o
04-72	Floor 36 position - high	0 ~ 9999m		0	o	o	o	o		o
04-73	Floor 36 position - low	0.0 ~ 999.9mm		0.0	o	o	o	o		o
04-74	Floor 37 position - high	0 ~ 9999m		0	o	o	o	o		o
04-75	Floor 37 position - low	0.0 ~ 999.9mm		0.0	o	o	o	o		o
04-76	Floor 38 position - high	0 ~ 9999m		0	o	o	o	o		o
04-77	Floor 38 position - low	0.0 ~ 999.9mm		0.0	o	o	o	o		o
04-78	Floor 39 position - high	0 ~ 9999m		0	o	o	o	o		o
04-79	Floor 39 position - low	0.0 ~ 999.9mm		0.0	o	o	o	o		o
04-80	Floor 40 position - high	0 ~ 9999m		0	o	o	o	o		o
04-81	Floor 40 position - low	0.0 ~ 999.9mm		0.0	o	o	o	o		o
04-82	Floor 41 position - high	0 ~ 9999m		0	o	o	o	o		o
04-83	Floor 41 position - low	0.0 ~ 999.9mm		0.0	o	o	o	o		o
04-84	Floor 42 position - high	0 ~ 9999m		0	o	o	o	o		o
04-85	Floor 42 position - low	0.0 ~ 999.9mm		0.0	o	o	o	o		o
04-86	Floor 43 position - high	0 ~ 9999m		0	o	o	o	o		o
04-87	Floor 43 position - low	0.0 ~ 999.9mm		0.0	o	o	o	o		o
04-88	Floor 44 position - high	0 ~ 9999m		0	o	o	o	o		o
04-89	Floor 44 position - low	0.0 ~ 999.9mm		0.0	o	o	o	o		o
04-90	Floor 45 position - high	0 ~ 9999m		0	o	o	o	o		o
04-91	Floor 45 position - low	0.0 ~ 999.9mm		0.0	o	o	o	o		o
04-92	Floor 46 position - high	0 ~ 9999m		0	o	o	o	o		o
04-93	Floor 46 position - low	0.0 ~ 999.9mm		0.0	o	o	o	o		o
04-94	Floor 47 position - high	0 ~ 9999m		0	o	o	o	o		o
04-95	Floor 47 position - low	0.0 ~ 999.9mm		0.0	o	o	o	o		o

05 Parameters for Floor Display

↗: The parameter can be set during operation

☑ represents that the parameter can be configured as shown/hidden

Parameter code	Function of the parameter	Parameter range	level	Default value	VF	VFPG	SVC	FOCPG	TQCPG	FOCPM
05-00	Physical floor 1 indication	0~9999		1	○	○	○	○		○
05-01	Physical floor 2 indication			2	○	○	○	○		○
05-02	Physical floor 3 indication	Settings: XX YY		3	○	○	○	○		○
05-03	Physical floor 4 indication	XX: Tens digit		4	○	○	○	○		○
05-04	Physical floor 5 indication	YY: Units digit		5	○	○	○	○		○
05-05	Physical floor 6 indication			6	○	○	○	○		○
05-06	Physical floor 7 indication	00='0'		7	○	○	○	○		○
05-07	Physical floor 8 indication	01='1'		8	○	○	○	○		○
05-08	Physical floor 9 indication	02='2'		9	○	○	○	○		○
05-09	Physical floor 10 indication	03='3'		100	○	○	○	○		○
05-10	Physical floor 11 indication	04='4'		101	○	○	○	○		○
05-11	Physical floor 12 indication	05='5'		102	○	○	○	○		○
05-12	Physical floor 13 indication	06='6'		103	○	○	○	○		○
05-13	Physical floor 14 indication	07='7'		104	○	○	○	○		○
05-14	Physical floor 15 indication	08='8'		105	○	○	○	○		○
05-15	Physical floor 16 indication	09='9'		106	○	○	○	○		○
05-16	Physical floor 17 indication	10='A'		107	○	○	○	○		○
05-17	Physical floor 18 indication	11='B'		108	○	○	○	○		○
05-18	Physical floor 19 indication	12='G'		109	○	○	○	○		○
05-19	Physical floor 20 indication	13='H'		200	○	○	○	○		○
05-20	Physical floor 21 indication	14='L'		201	○	○	○	○		○
05-21	Physical floor 22 indication	15='M'		202	○	○	○	○		○
05-22	Physical floor 23 indication	16='P'		203	○	○	○	○		○
05-23	Physical floor 24 indication	17='R'		204	○	○	○	○		○
05-24	Physical floor 25 indication	18='-'		205	○	○	○	○		○
05-25	Physical floor 26 indication	19='"		206	○	○	○	○		○
05-26	Physical floor 27 indication	20='X'		207	○	○	○	○		○
05-27	Physical floor 28 indication	21=Up icon		208	○	○	○	○		○
05-28	Physical floor 29 indication	22=Down icon		209	○	○	○	○		○
05-29	Physical floor 30 indication			300	○	○	○	○		○
05-30	Physical floor 31 indication			301	○	○	○	○		○
05-31	Physical floor 32 indication			302	○	○	○	○		○
05-32	Physical floor 33 indication			303	○	○	○	○		○
05-33	Physical floor 34 indication			304	○	○	○	○		○
05-34	Physical floor 35 indication			305	○	○	○	○		○
05-35	Physical floor 36 indication			306	○	○	○	○		○
05-36	Physical floor 37 indication			307	○	○	○	○		○
05-37	Physical floor 38 indication			308	○	○	○	○		○
05-38	Physical floor 39 indication			309	○	○	○	○		○
05-39	Physical floor 40 indication			400	○	○	○	○		○
05-40	Physical floor 41 indication			401	○	○	○	○		○
05-41	Physical floor 42 indication			402	○	○	○	○		○
05-42	Physical floor 43 indication			403	○	○	○	○		○
05-43	Physical floor 44 indication			404	○	○	○	○		○
05-44	Physical floor 45 indication			405	○	○	○	○		○
05-45	Physical floor 46 indication			406	○	○	○	○		○
05-46	Physical floor 47 indication			407	○	○	○	○		○

06 Parameters for Speed Control

↗: The parameter can be set during operation

☑ represents that the parameter can be configured as shown/hidden

Parameter code	Function of the parameter	Parameter range	level	Default value	VF	VFP	SVC	FOCPG	TQCPG	FOCPM
↗ 06-00	Acceleration	0.00 ~ 2.00m/s ²		0.50	○	○	○	○		○
↗ 06-01	Deceleration	0.00 ~ 2.00m/s ²		0.50	○	○	○	○		○
↗ 06-02	Forced deceleration	0.00~2.00 m/s ²		0.75	○	○	○	○		○
↗ 06-03	S-curve for Acceleration Departure Time S1	0.00 ~ 25.00 seconds		2.00	○	○	○	○		○
↗ 06-04	S-curve for Acceleration Arrival Time S2	0.00 ~ 25.00 seconds		2.00	○	○	○	○		○
↗ 06-05	S-curve for Deceleration Departure Time S3	0.30 ~ 4.00 seconds		2.00	○	○	○	○		○
↗ 06-06	S-curve for Deceleration Arrival Time S4	0.30 ~ 4.00 seconds		2.00	○	○	○	○		○
↗ 06-07	Landing deceleration	0.00~20.00 m/s ²		20.00	○	○	○	○		○
↗ 06-08	Reserved speed (zero speed)	0.10 ~ 4.00 m/s		0.00	○	○	○	○		○
↗ 06-09	Reserved speed (stepless)	0.10 ~ 4.00 m/s		0.02	○	○	○	○		○
↗ 06-10	Floor searching speed	0.10 ~ 4.00 m/s		0.10	○	○	○	○		○
↗ 06-11	Inspection speed	0.10 ~ 4.00 m/s		0.10	○	○	○	○		○
↗ 06-12	Leveling speed	0.10 ~ 4.00 m/s		0.05	○	○	○	○		○
↗ 06-13	Fast operation speed	0.10 ~ 4.00 m/s		1.00	○	○	○	○		○
↗ 06-14	Rescue speed	0.10 ~ 4.00 m/s		0.10	○	○	○	○		○
↗ 06-15	Brake Release Delay Time when Elevator Starts	0.000 ~ 65.000 seconds		0.250	○	○	○	○	○	○
↗ 06-16	Brake Engage Delay Time when Elevator Stops	0.000 ~ 65.000 seconds		0.250	○	○	○	○	○	○
↗ 06-17	Turn On Delay of Magnetic Contactor between Drive and Motor	0.000 ~ 65.000 seconds		0.200	○	○	○	○	○	○
↗ 06-18	Turn Off Delay of Magnetic Contactor between Drive and Motor	0.000 ~ 65.000 seconds		0.200	○	○	○	○	○	○
↗ 06-19	DC brake current level	0~100%		0	○	○	○			
↗ 06-20	DC brake time at startup	0.0 ~ 60.0 seconds		1.0	○	○	○	○		○
↗ 06-21	DC brake time at stop	0.0 ~ 60.0 seconds		0.0	○	○	○	○		○
↗ 06-22	Time for Decreasing Torque at Stop	0.000 ~ 5.000 seconds		0.000				○	○	○
06-23	Position of lower limit - high	0 ~ 9999m		0	○	○	○	○		○
06-24	Position of lower limit - low	0.0 ~ 999.9mm		0.0	○	○	○	○		○
06-25	Downward 1 st level forced deceleration position - high	0 ~ 9999m		0	○	○	○	○		○
06-26	Downward 1 st level forced deceleration position - low	0.0 ~ 999.9mm		0.0	○	○	○	○		○
06-27	Downward 2 nd level forced deceleration position - high	0 ~ 9999m		0	○	○	○	○		○
06-28	Downward 2 nd level forced deceleration position - low	0.0 ~ 999.9mm		0.0	○	○	○	○		○

06-29	Downward 3rd level forced deceleration position - high	0 ~ 9999m		0	○	○	○	○	○	○
06-30	Downward 3rd level forced deceleration position - low	0.0 ~ 999.9mm		0.0	○	○	○	○	○	○
06-31	Position of upper limit - high	0 ~ 9999m		0	○	○	○	○	○	○
06-32	Position of upper limit - low	0.0 ~ 999.9mm		0.0	○	○	○	○	○	○
06-33	Upward 1 st level forced deceleration position - high	0 ~ 9999m		0	○	○	○	○	○	○
06-34	Upward 1 st level forced deceleration position - low	0.0 ~ 999.9mm		0.0	○	○	○	○	○	○
06-35	Upward 2 nd level forced deceleration - high	0 ~ 9999m		0	○	○	○	○	○	○
06-36	Upward 2 nd level forced deceleration - low	0.0 ~ 999.9mm		0.0	○	○	○	○	○	○
06-37	Upward 3 rd level forced deceleration - high	0 ~ 9999m		0	○	○	○	○	○	○
06-38	Upward 3 rd level forced deceleration - low	0.0 ~ 999.9mm		0.0	○	○	○	○	○	○
↗ 06-39	Distance margin for landing deceleration	0.0 ~ 6000.0mm		100.0	○	○	○	○	○	○

07 Parameters for Advanced Speed Control

↗: The parameter can be set during operation

☑ represents that the parameter can be configured as shown/hidden

Parameter code	Function of the parameter	Parameter range	level	Default value	VF	VFP	SVC	FOCPG	TQCPG	FOCPM
↗ 07-00	Inertia Ratio	1~300%		60				○		○
↗ 07-01	Zero-speed bandwidth	0 ~ 40Hz		10				○		○
↗ 07-02	Low-speed bandwidth	0 ~ 40Hz		10				○		○
↗ 07-03	High-speed bandwidth	0 ~ 40Hz		10				○		○
↗ 07-04	Zero-speed bandwidth at landing	0 ~ 40Hz		10				○		○
↗ 07-05	Zero-speed ASR P gain	0.0~500.0%		100.0	○	○	○	○		○
↗ 07-06	Zero-speed ASR integration time I	0.000 ~ 10.000 seconds		0.100	○	○	○	○		○
↗ 07-07	ASR P1 gain	0.0~500.0%		100.0	○	○	○	○		○
↗ 07-08	ASR integration time I1	0.000 ~ 10.000 seconds		0.100	○	○	○	○		○
↗ 07-09	ASR P2 gain	0.0~500.0%		100.0	○	○	○	○		○
↗ 07-10	ASR integration time I2	0.000 ~ 10.000 seconds		0.100	○	○	○	○		○
↗ 07-11	Zero-speed ASR P gain at landing	0.0~500.0%		100.0	○	○	○	○		○
↗ 07-12	Zero-speed ASR integration time I at landing	0.000 ~ 10.000 seconds		0.100	○	○	○	○		○
↗ 07-13	Low/high speed switching frequency	0.00 ~ 6.67m/s (0: no effect)		0.12	○	○	○	○		○
↗ 07-14	ASR Primary Low Pass Filter Gain	0.000 ~ 0.350 seconds		0.008	○	○	○	○		○
↗ 07-15	Zero-speed/Low-speed bandwidth adjustment	0.00 ~ 6.67m/s		0.08						○
↗ 07-16	Low-speed/High-speed bandwidth adjustment	0.00 ~ 6.67m/s		0.08		○		○		○
↗ 07-17	Forward Motor Torque limit	0~300%		200				○	○	○
↗ 07-18	Forward Regenerative Torque Limit	0~300%		200				○	○	○
↗ 07-19	Reverse Motor Torque Limit	0~300%		200				○	○	○
↗ 07-20	Reverse Regenerative Torque Limit	0~300%		200				○	○	○
↗ 07-21	PDF gain	0~200%		30				○		○
↗ 07-22	Gain for Speed Feed Forward	0~500%		0				○		○
↗ 07-23	Operation Time of Zero Speed	0.000 ~ 65.535 seconds		0.450						○
↗ 07-24	Zero Speed Gain (P)	0~655.00%		100.00						○
↗ 07-25	Low pass filter time at the starting position	0.000 ~ 65.535 seconds		0.800						○
↗ 07-26	Direct landing position control P gain	0.0~655.00 %		2.00				○		○
↗ 07-27	Low pass filter time for direct landing position control	0 ~ 1.000 seconds		0.018				○		○
↗ 07-28	Position control ASR P gain	0.0~1000.0		100.0						
↗ 07-29	Position control ASR integration time I	0.000 ~ 10.000 seconds		0.100						

08 Parameters for Elevator Functions

↗: The parameter can be set during operation

☑ represents that the parameter can be configured as shown/hidden

Parameter code	Function of the parameter	Parameter range	level	Default value	VF	VFP	SVC	FOCPG	TQCPG	FOCPM
08-00	Elevator's topmost floor	Floor 1 ~ 47		5	○	○	○	○		○
08-01	Elevator's down-most floor	Floor 1 ~ 47		1	○	○	○	○		○
08-02	Elevator base station	Floor 1 ~ 47		1	○	○	○	○		○
08-03	Fire base station	Floor 1 ~ 47		1	○	○	○	○		○
08-04	Elevator lock base station	Floor 1 ~ 47		1	○	○	○	○		○
08-05	Service floor 1	0 ~ FFFFh		FFFFh	○	○	○	○		○
08-06	Service floor 2	0 ~ FFFFh		FFFFh	○	○	○	○		○
08-07	Service floor 3	0 ~ FFFFh		FFFFh	○	○	○	○		○
08-08	Number of elevators for group control	1~8		1	○	○	○	○		○
08-09	Elevator No. in group control	1~8		1	○	○	○	○		○
08-10	Group control selection	b0: 1: Group control		0	○	○	○	○		○
08-11	Leveling sensor delay time	10 ~ 50ms		14	○	○	○	○		○
08-12	Security floor	Floor 1 ~ 47		1	○	○	○	○		○
↗ 08-13	Collective selection method	0: Collectively select all 1: Lower collective selection 2: Upper collective selection			○	○	○	○		○
08-14	Lower collective selection 1 start time (hr/min)	00.00~23.59		00.00	○	○	○	○		○
08-15	Lower collective selection 1 end time (hr/min)	00.00~23.59		00.00	○	○	○	○		○
08-16	Lower collective selection 2 start time (hr/min)	00.00~23.59		00.00	○	○	○	○		○
08-17	Lower collective selection 2 end time (hr/min)	00.00~23.59		00.00	○	○	○	○		○
08-18	Time Period service 1 start (hr/min)	00.00~23.59		00.00	○	○	○	○		○
08-19	Time Period service 1 end (hr/min)	00.00~23.59		00.00	○	○	○	○		○
08-20	Time Period service 1 service floor 1	Hexadecimal: 01~16 floors. Set 1 for enable answering command		FFFFh	○	○	○	○		○
08-21	Time Period service 1 service floor 2	Hexadecimal: 17~32 floors. Set 1 for enable answering command		FFFFh	○	○	○	○		○
08-22	Time Period service 1 service floor 3	Hexadecimal: 33~48 floors. Set 1 for enable answering command		FFFFh	○	○	○	○		○
08-23	Time Period service 2 start (hr/min)	00.00~23.59		00.00	○	○	○	○		○
08-24	Time Period service 2 end (hr/min)	00.00~23.59		00.00	○	○	○	○		○
08-25	Time Period service 2 service floor 1	Hexadecimal: 01~16 floors. Set 1 for enable answering command		FFFFh	○	○	○	○		○
08-26	Time Period service 2 service floor 2	Hexadecimal: 17~32 floors. Set 1 for enable answering command		FFFFh	○	○	○	○		○
08-27	Time Period service 2 service floor 3	Hexadecimal: 33~48 floors. Set 1 for enable answering command		FFFFh	○	○	○	○		○

Elevator Commissioning Guide

Parameter code	Function of the parameter	Parameter range	level	Default value	VF	VFP	SVC	FOCPG	TQCPG	FOCPM
08-28	Peak 1 start time (hr/min)	00.00~23.59		00.00	○	○	○	○		○
08-29	Peak 1 end time (hr/min)	00.00~23.59		00.00	○	○	○	○		○
08-30	Peak 1 floor	Floor 1 ~ 47		1	○	○	○	○		○
08-31	Peak 2 start time (hr/min)	00.00~23.59		00.00	○	○	○	○		○
08-32	Peak 2 end time (hr/min)	00.00~23.59		00.00	○	○	○	○		○
08-33	Peak 2 floor	Floor 1 ~ 47		1	○	○	○	○		○
08-34	Test floor 1	Floor 1 ~ 47		0	○	○	○	○		○
08-35	Test floor 2	Floor 1 ~ 47		0	○	○	○	○		○
08-36	Test floor 3	Floor 1 ~ 47		0	○	○	○	○		○
08-37	Times of test	0~60000 : Times of test >60000: Infinite number of tests		0	○	○	○	○		○
08-38	Disable external display board	0: Car-top board is valid, external display board is valid 1: Car-top board is valid, external display board is invalid 2: Car-top board is invalid, external display board is valid 3: Car-top board is invalid, external display board is invalid		0	○	○	○	○		○
08-39	Disable door open	0: Door open is enabled 1: Door open is disabled 2: Door motor jog test (under inspection mode)		0	○	○	○	○		○
08-40	Overload function selection	0: Disable overload operation 1: Enable overload operation		0	○	○	○	○		○
08-41	Disable limit switches	0: Limit switches are enabled 1: Limit switches are disabled		0	○	○	○	○		○
08-42	Anti-nuisance function	0: This function is disabled 1: This function is enabled		0	○	○	○	○		○
08-43	Operation speed under emergency power supply	0.00 ~ 6.67m/s		0.00	○	○	○	○		○
08-44	Options at power shut off	0: Motor does not run 1: Motor runs under UPS power supply		0	○	○	○	○		○
08-45	Time for returning to base station when being idle	1 ~ 240min		10	○	○	○	○		○
08-46	Time for turning off fans and lights	0 ~ 60000 seconds		300	○	○	○	○		○
08-47	Allowed Time interval for floor movement	0 ~ 45 seconds		45	○	○	○	○		○
08-48	Factory function 1	b9: disabled people mode setting 1 : Enabled b10:Emergency power supply PM motor self-sliding mode setting 1: Enabled b11: Emergency power supply post-stop action. Setting 1: Door open till hold time, and then door closed to position, then shut off the power 0: Door open to position and does not shut off the power b12: Door leveling after open b13: External display board continuing triggering mode		0080h	○	○	○	○		○

Parameter code	Function of the parameter	Parameter range	level	Default value	VF	VFPG	SVC	FOCPG	TQCPG	FOCPM
08-49	Factory function 2	b0: Automatic fire operation mode enable b3: Stop output after the door motor attains to the limit b5: Operator control mode with non-stop switch setting: 1 built-in b12: Ignore returning base station after power recovery b13: For home elevator only: (no inner door) door motor handling mode b15: Output/Input display (0: terminal function status 1: terminal external status)		0000h	○	○	○	○		○
08-50	Hoistway self-learning	0: Stop hoistway self-learning 1: Start hoistway self-learning		0	○	○	○	○		○
08-51	Automatic fault resets time	0: No automatic reset function 0 ~ 30000 times		0	○	○	○	○		○
08-52	Interval of automatic reset	0 ~ 60 seconds		3	○	○	○	○		○

09 Parameters for Door Control

↗: The parameter can be set during operation

☑ represents that the parameter can be configured as shown/hidden

Parameter code	Function of the parameter	Parameter range	level	Default value	VF	VFP	SVC	FOCPG	TQCPG	FOCPM
09-00	Number of door motors	0: 1 units 1: 2 units		0	○	○	○	○		○
09-01	Car-top board software version	0~99		FFFFh	○	○	○	○		○
09-02	Door motor 1 Service Floor 1	0 ~ FFFFh		FFFFh	○	○	○	○		○
09-03	Door motor 1 Service Floor 2	0 ~ FFFFh		FFFFh	○	○	○	○		○
09-04	Door motor 1 Service Floor 3	0 ~ FFFFh		FFFFh	○	○	○	○		○
09-05	Door motor 2 Service Floor 1	0 ~ FFFFh		FFFFh	○	○	○	○		○
09-06	Door motor 2 Service Floor 2	0 ~ FFFFh		FFFFh	○	○	○	○		○
09-07	Door motor 2 Service Floor 3	0 ~ FFFFh		FFFFh	○	○	○	○		○
09-08	Door open time protection	5 ~ 99 seconds		10	○	○	○	○		○
09-09	Door close time protection	5 ~ 99 seconds		15	○	○	○	○		○
09-10	Door open/close times	0 ~ 20 times		0	○	○	○	○		○
09-11	Door status at movement base station	0: Normal door closing 1: Open door and wait		0	○	○	○	○		○
09-12	Door open holding time by external display board	1 ~ 30 seconds		5	○	○	○	○		○
09-13	Door open holding time by in-car display board	1 ~ 30 seconds		3	○	○	○	○		○
09-14	Door open holding time at base station	1 ~ 30 seconds		10	○	○	○	○		○
09-15	Delay time for arrival alarm output	0 ~ 1000ms		0	○	○	○	○		○

10 Parameters for Car-top Board Multi-function Output/Input

↗: The parameter can be set during operation

☑ represents that the parameter can be configured as shown/hidden

Parameter code	Function of the parameter	Parameter range	level	Default value	VF	VFP	SVC	FOCPG	TQCPG	FOCPM
10-00	Car-top board input command 1	0: No function		101	○	○	○	○	○	○
10-01	Car-top board input command 2	1: Front door open limit (Normal Open)		102	○	○	○	○	○	○
10-02	Car-top board input command 3	2: Front door close limit (Normal Open)		103	○	○	○	○	○	○
10-03	Car-top board input command 4	3: Front door light curtain input (Normal Open)		105	○	○	○	○	○	○
10-04	Car-top board input command 5	4: Front door open request (Normal Open)		106	○	○	○	○	○	○
10-05	Car-top board input command 6	5: Rear door open limit (Normal Open)		107	○	○	○	○	○	○
10-06	Car-top board input command 7	6: Rear door close limit (Normal Open)		9	○	○	○	○	○	○
10-07	Car-top board input command 8	7: Rear door light curtain input (Normal Open)		10	○	○	○	○	○	○
10-08	Command board 2 input command 1	8: Rear door open request (Normal Open)		0	○	○	○	○	○	○
10-09	Command board 2 input command 2	9: Overload input (Normal Open)		0	○	○	○	○	○	○
10-10	Command board 2 input command 3	10: Full load input (Normal Open)		0	○	○	○	○	○	○
10-11	Command board 2 input command 4	11: Front door open button (Normal Open)		0	○	○	○	○	○	○
10-12	Command board 2 input command 5	12: Front door close button (Normal Open)		0	○	○	○	○	○	○
10-13	Command board 2 input command 6	13: Front door open delay button (Normal Open)		0	○	○	○	○	○	○
10-14	Command board 2 input command 7	14: VIP mode switch (Normal Open)		0	○	○	○	○	○	○
10-15	Command board 2 input command 8	15: Operator control switch (Normal Open)		0	○	○	○	○	○	○
10-16	Command board 1 input command 1	16: Operator non-stop control switch (Normal Open)		11	○	○	○	○	○	○
10-17	Command board 1 input command 2	17: Independent operation switch (Normal Open)		12	○	○	○	○	○	○
10-18	Command board 1 input command 3	18: 1 st level fire rescue switch (Normal Open)		13	○	○	○	○	○	○
10-19	Command board 1 input command 4	19: Car-top inspection switch (Normal Open)		14	○	○	○	○	○	○
10-20	Command board 1 input command 5	20: Car-top inspection up-going (Normal Open)		15	○	○	○	○	○	○
10-21	Command board 1 input command 6	21: Car-top inspection down-going (Normal Open)		16	○	○	○	○	○	○
10-22	Command board 1 input command 7	22: Emergency stop input (Normal Open)		17	○	○	○	○	○	○
10-23	Command board 1 input command 8	23: Light control input (Normal Open)		18	○	○	○	○	○	○
		24: Fan control input (Normal Open)								
		25: Rear door open button (Normal Open)								
		26: Rear door close button (Normal Open)								
		27: Rear door open delay button (Normal Open)								

Parameter code	Function of the parameter	Parameter range	level	Default value	VF	VFP	SVC	FOCPG	TQCPG	FOCPM
		28: Operator direction up-going switch (Normal Open)								
		29: Operator direction down-going switch (Normal Open)								
		30: Jog up-going (Normal Open)								
		31: Jog down-going (Normal Open)								
		32: Light load switch input (Normal Open)								
		33: Front door safety panel (Normal Open)								
		34: Rear door safety panel (Normal Open)								
		101: Front door open limit (Normal Close)								
		102: Front door close limit (Normal Close)								
		103: Front door light curtain input (Normal Close)								
		104: Front door open request (Normal Close)								
		105: Rear door open limit (Normal Close)								
		106: Rear door close limit (Normal Close)								
		107: Rear door light curtain input (Normal Close)								
		108: Rear door open request (Normal Close)								
		109: Overload input (Normal Close)								
		110: Full load input (Normal Close)								
		111: Front door open button (Normal Close)								
		112: Front door close button (Normal Close)								
		113: Front door open delay button (Normal Close)								
		114: VIP mode switch (Normal Close)								
		115: Operator control switch (Normal Close)								
		116: Operator non-stop control switch (Normal Close)								
		117: Independent operation switch (Normal Close)								
		118: 1 st level fire rescue switch (Normal Close)								
		119: Car-top inspection switch (Normal Close)								
		120: Car-top inspection up-going (Normal Close)								
		121: Car-top inspection down-going (Normal Close)								
		122: Emergency stop input (Normal Close)								
		123: Light control input (Normal Close)								
		124: Fan control input (Normal Close)								
		125: Rear door open button (Normal Close)								
		126: Rear door close button (Normal Close)								
		127: Rear door open delay button (Normal Close)								
		128: Operator direction up-going switch (Normal Close)								
		129: Operator direction down-going switch (Normal Close)								
		130: Jog up-going (Normal Close)								
		131: Jog down-going (Normal Close)								
		132: Light load switch input (Normal Close)								
		133: Front door safety panel (Normal Close)								
		134: Rear door safety panel (Normal Close)								
10-24	Car-top board output command 1	0: No function		1	○	○	○	○	○	○
10-25	Car-top board output command 2	1: Front door open output (Normal Open)		2	○	○	○	○	○	○

Parameter code	Function of the parameter	Parameter range	level	Default value	VF	VFP	SVC	FOCPG	TQCPG	FOCPM
10-26	Car-top board output command 3	2: Front door close output (Normal Open)		3	○	○	○	○	○	○
10-27	Car-top board output command 4	3: Rear door open output (Normal Open)		4	○	○	○	○	○	○
10-28	Car-top board output command 5	4: Rear door close output (Normal Open)		5	○	○	○	○	○	○
10-29	Car-top board output command 6	5: Overload signal output (communication)(Normal Open)		6	○	○	○	○	○	○
10-30	Car-top board output command 7	6: Full-load signal output (Normal Open)		7	○	○	○	○	○	○
10-31	Car-top board output command 8	7: Buzzer output (Normal Open)		8	○	○	○	○	○	○
10-32	Command board 2 output command 1	8: Light output (Normal Open)		0	○	○	○	○	○	○
10-33	Command board 2 output command 2	9: Fan output (Normal Open)		0	○	○	○	○	○	○
10-34	Command board 2 output command 3	10: Front door is opening (Normal Open)		0	○	○	○	○	○	○
10-35	Command board 2 output command 4	11: Front door is closing (Normal Open)		0	○	○	○	○	○	○
10-36	Command board 2 output command 5	12: Front door open delay display (Normal Open)		0	○	○	○	○	○	○
10-37	Command board 2 output command 6	13: Non-stop operation display (Normal Open)		0	○	○	○	○	○	○
10-38	Command board 2 output command 7	14: Operation control display (Normal Open)		0	○	○	○	○	○	○
10-39	Command board 2 output command 8	15: Operation direction change display (Normal Open)		0	○	○	○	○	○	○
10-40	Command board 1 output command 1	16: Independent operation display (Normal Open)		10	○	○	○	○	○	○
10-41	Command board 1 output command 2	17: 1 st level fire rescue display (Normal Open)		11	○	○	○	○	○	○
10-42	Command board 1 output command 3	18: Elevator landing (Normal Open)		12	○	○	○	○	○	○
10-43	Command board 1 output command 4	19: Elevator stops (Normal Open)		13	○	○	○	○	○	○
10-44	Command board 1 output command 5	20: Elevator up-going output (Normal Open)		14	○	○	○	○	○	○
10-45	Command board 1 output command 6	21: Elevator down-going output (Normal Open)		15	○	○	○	○	○	○
10-46	Command board 1 output command 7	22: Error display output (Normal Open)		16	○	○	○	○	○	○
10-47	Command board 1 output command 8	23: Front door reset output (Normal Open)		17	○	○	○	○	○	○
10-48	Car-top board output command 9	24: Front door slow close output (Normal Open)		0	○	○	○	○	○	○
		25: Rear door reset output (Normal Open)								
		26: Rear door slow close output (Normal Open)								
		27: Rear door is opening (Normal Open)								
		28: Rear door is closing (Normal Open)								
		29: Rear door open delay display (Normal Open)								
		101: Front door open output (Normal Close)								
		102: Front door close output (Normal Close)								
103: Rear door open output (Normal Close)										
104: Rear door close output (Normal Close)										

Parameter code	Function of the parameter	Parameter range	level	Default value	VF	VFP	SVC	FOCPG	TQCPG	FOCPM
		105: Overload signal output (communication)(Normal Close)								
		106: Full-load signal output (Normal Close)								
		107: Buzzer output (Normal Close)								
		108: Light output (Normal Close)								
		109: Fan output (Normal Close)								
		110: Front door is opening (Normal Close)								
		111: Front door is closing (Normal Close)								
		112: Front door open delay display (Normal Close)								
		113: Non-stop operation display (Normal Close)								
		114: Operation control display (Normal Close)								
		115: Operation direction change display (Normal Close)								
		116: Independent operation display (Normal Close)								
		117: 1 st level fire rescue display (Normal Close)								
		118: Elevator landing (Normal Close)								
		119: Elevator stops (Normal Close)								
		120: Elevator up-going output (Normal Close)								
		121: Elevator down-going output (Normal Close)								
		122: Error display output (Normal Close)								
		123: Front door reset output (Normal Close)								
		124: Front door slow close output (Normal Close)								
		125: Rear door reset output (Normal Close)								
		126: Rear door slow close output (Normal Close)								
		127: Rear door is opening (Normal Close)								
		128: Rear door is closing (Normal Close)								
		129: Rear door open delay display (Normal Close)								
10-49	Digital input Operation direction 1	0 ~ FFFFh		0	○	○	○	○	○	○
10-50	Digital input Operation direction 2	0 ~ FFFFh		0	○	○	○	○	○	○
10-51	Digital output direction 1	0 ~ FFFFh		0	○	○	○	○	○	○
10-52	Digital output direction 2	0 ~ FFFFh		0	○	○	○	○	○	○

11 Parameters for Protection

↗: The parameter can be set during operation

☑ represents that the parameter can be configured as shown/hidden

Parameter code	Function of the parameter	Parameter range	level	Default value	VF	VFP	SVC	FOCPG	TQCPG	FOCPM
↗ 11-00	Detection Time of Mechanical Brake	0.00 ~ 10.00 seconds		0.00	○	○	○	○	○	○
↗ 11-01	Detection Time of contactor	0.00 ~ 10.00 seconds		0.00	○	○	○	○	○	○
↗ 11-02	Brake Chopper Level	230Vseries: 350.0 ~ 450.0Vdc 460Vseries: 700.0 ~ 900.0Vdc		380.0 760.0	○	○	○	○	○	○
↗ 11-03	Low voltage level	230Vseries: 160.0 ~ 220.0Vdc 460Vseries: 320.0 ~ 440.0Vdc	☑	180.0 360.0	○	○	○	○	○	○
↗ 11-04	Phase-loss protection	0: Warn and keep operation 1: Warn and ramp to stop 2: Warn and coast to stop	☑	2	○	○	○	○	○	○
↗ 11-05	Current limit	0~200%	☑	150				○	○	○
↗ 11-06	Heat Sink Over-heat (OH) Warning	0.0~110.0℃	☑	90.0	○	○	○	○	○	○
↗ 11-07	PTC (Positive Temperature Coefficient) Detection Treatment	0: Warn and keep operation 1: Warn and ramp to stop	☑	0	○	○	○	○	○	○
↗ 11-08	PTC level	0.0~100.0%	☑	50.0	○	○	○	○	○	○
↗ 11-09	Filter Time for PTC Detection	0.00 ~ 10.00 seconds	☑	0.20	○	○	○	○	○	○
	11-10	Power supply voltage under emergency operation	☑	48.0 96.0	○	○	○	○	○	○
	11-11	Power supply capacity under emergency operation	☑	0.0	○	○	○	○	○	○
	11-12	Phase loss detection of motor output	☑	0	○	○	○	○	○	○
↗ 11-13	Error action treatment	bit0 = 0: Low-voltage error and coast to stop bit0 = 1: Low-voltage warning and coast to stop bit1 = 0: Fan error and coast to stop bit1 = 1: Fan warning and coast to stop	☑	2	○	○	○	○	○	○
	11-14	Check Torque Output Function	☑	0	○	○	○	○	○	○
↗ 11-15	Encoder feedback signal error treatment	0: Warn and keep operation 1: Warn and ramp to stop 2: Warn and stop operation	☑	2		○		○	○	
↗ 11-16	Detection time for encoder feedback fault	0.0 ~ 10.0 seconds	☑	1.0		○		○	○	
↗ 11-17	Encoder stall level	0 ~ 120%/s (0: no effect)	☑	115		○	○	○		○
↗ 11-18	Encoder stall detection time	0.0 ~ 2.0 seconds	☑	0.1		○	○	○		○
↗ 11-19	Encoder slip range	0 ~ 50%/s (0: no effect)	☑	50		○	○	○		○
↗ 11-20	Encoder slip detection time	0.0 ~ 10.0 seconds	☑	0.5		○	○	○		○
↗ 11-21	Encoder stall and slip treatment	0: Warn and keep operation 1: Warn and ramp to stop 2: Warn and coast to stop	☑	2		○	○	○		

12 Parameters for Communication

↗: The parameter can be set during operation

☑ represents that the parameter can be configured as shown/hidden

Parameter code	Function of the parameter	Parameter range	level	Default value	VF	VFP	SVC	LD	LD	LD	LD	LD	LD
↗ 12-00	Communication address	1~254		1	○	○	○	○	○	○	○	○	○
↗ 12-01	Communication transmission rate (Keypad)	4.8 ~ 115.2Kbps		19.2	○	○	○	○	○	○	○	○	○
↗ 12-02	Transmission fault treatment (Keypad)	0: Warn and continue operation 1: Warn and ramp to stop 2: Reserved 3: Bypass without treatment		13	○	○	○	○	○	○	○	○	○
↗ 12-03	Communication transmission rate (Remote)	4.8 ~ 115.2Kbps		19.2	○	○	○	○	○	○	○	○	○
↗ 12-04	Communication format (Remote)	0: 7N1 (ASCII) 1: 7N2 (ASCII) 2: 7E1 (ASCII) 3: 7O1 (ASCII) 4: 7E2 (ASCII) 5: 7O2 (ASCII) 6: 8N1 (ASCII) 7: 8N2 (ASCII) 8: 8E1 (ASCII) 9: 8O1 (ASCII) 10: 8E2 (ASCII) 11: 8O2 (ASCII) 12: 8N1 (RTU) 13: 8N2 (RTU) 14: 8E1 (RTU) 15: 8O1 (RTU) 16: 8E2 (RTU) 17: 8O2 (RTU)		13	○	○	○	○	○	○	○	○	○
↗ 12-05	Transmission fault treatment (Keypad)	0: Warn and continue operation 1: Warn and ramp to stop 2: Reserved 3: Bypass without treatment	☑	3	○	○	○	○	○	○	○	○	○
↗ 12-06	Time-out detection (Keypad)	0.0 ~ 100.0 seconds	☑	0.0	○	○	○	○	○	○	○	○	○
↗ 12-07	Transmission fault treatment (Remote)	0: Warn and continue operation 1: Warn and ramp to stop 2: Reserved 3: Bypass without treatment	☑	3	○	○	○	○	○	○	○	○	○
↗ 12-08	Time-out detection (Remote)	0.0 ~ 100.0 seconds	☑	0.0	○	○	○	○	○	○	○	○	○
↗ 12-09	Communication response delay time	0.0 ~ 200ms	☑	2.0	○	○	○	○	○	○	○	○	○

5 Product Dimensions

Frame No. B

IED022A21A, IED037A21A, IED040A23A, IED040A43A

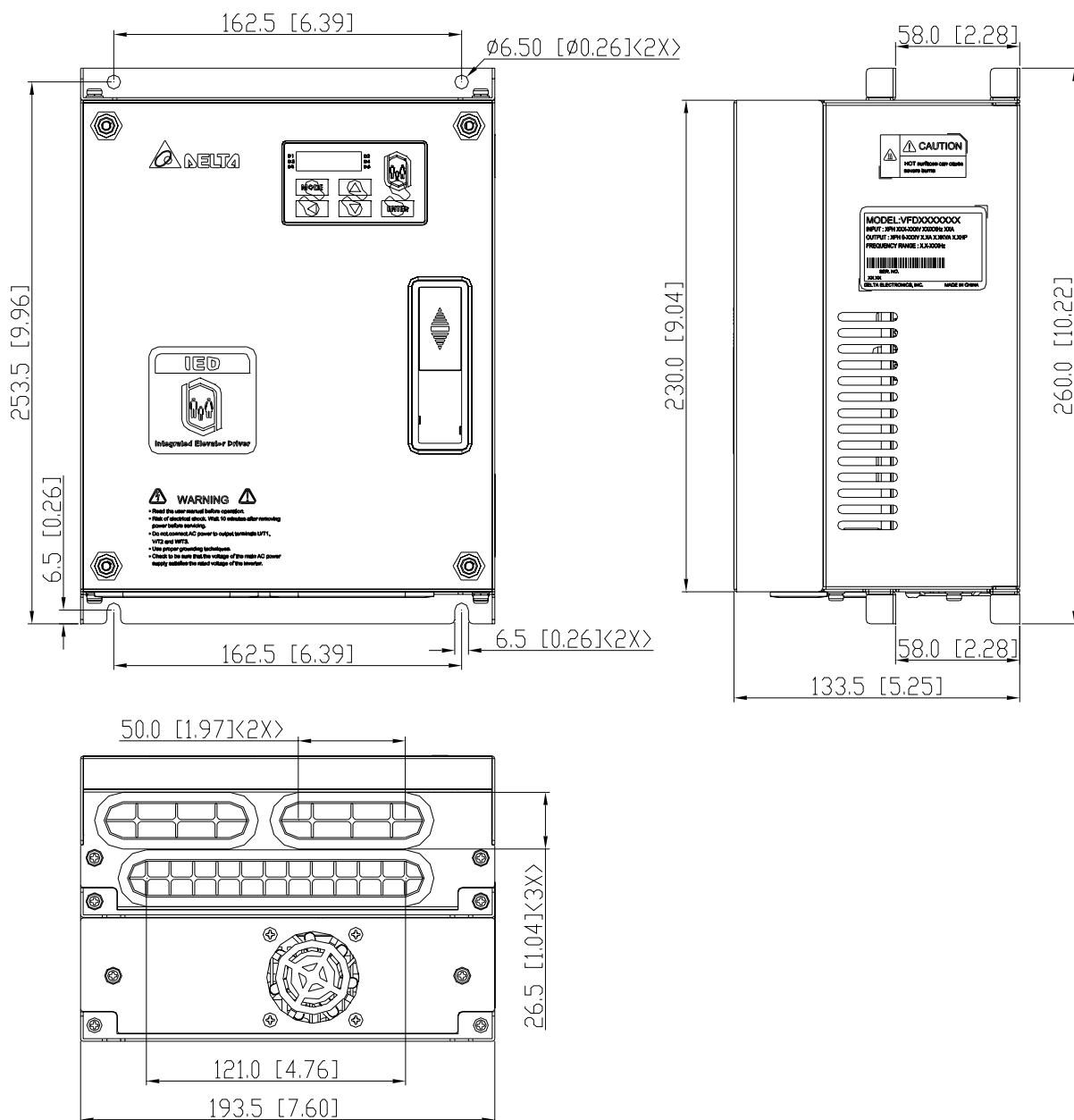

Frame No. C

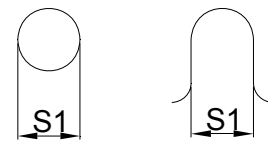
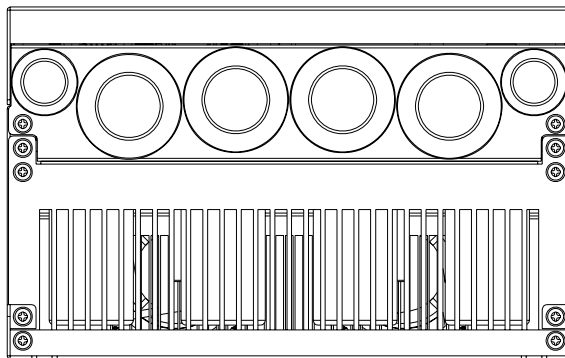
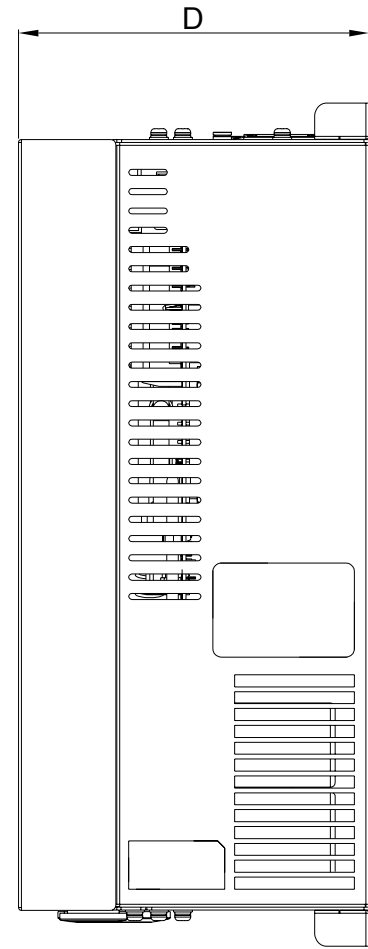
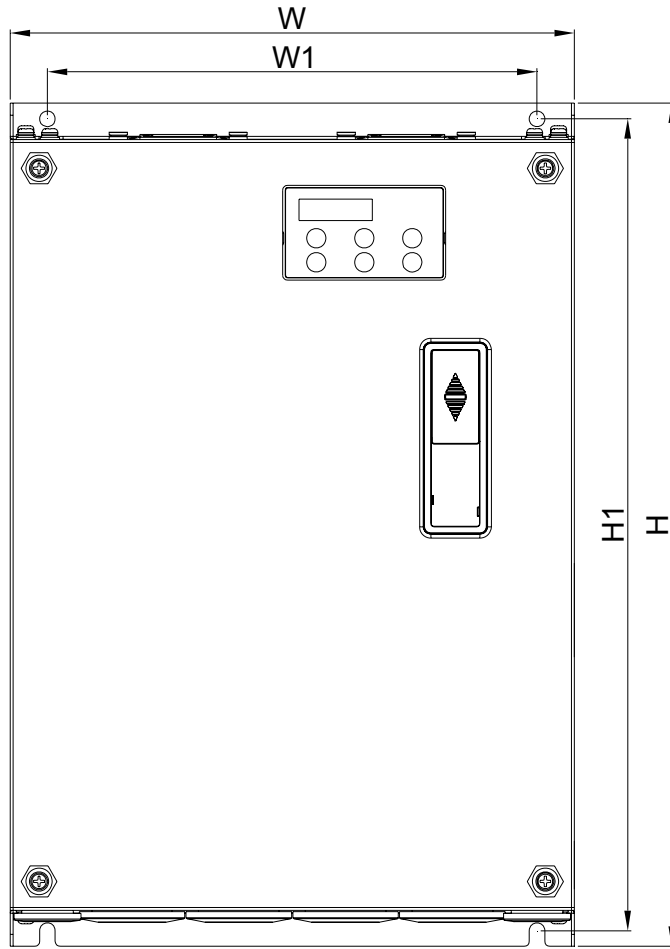

Unit: mm [inch]

Frame No.	W	W1	H	H1	H2	H3	D	Ø	Ø1	Ø2	Ø3
C	235 [9.25]	204 [8.03]	350 [13.78]	337 [13.27]	320 [12.60]	-	136 [5.35]	6.5 [0.26]	-	34 [1.34]	22 [0.87]

NOTE

Frame No. C: IED055A23A/43A, IED075A23A/43A, IED110A23A/43A,

Frame No. D

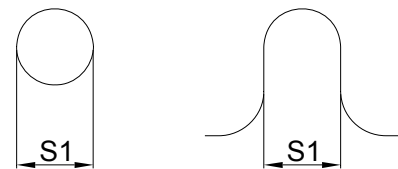
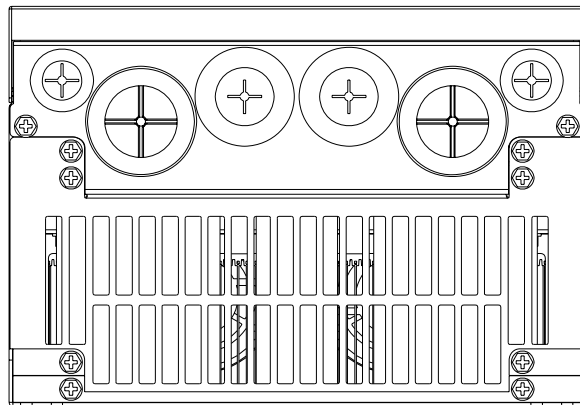
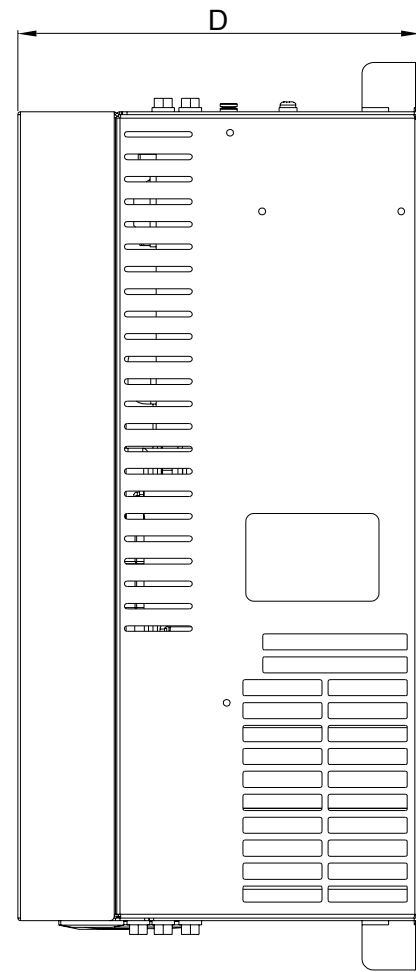
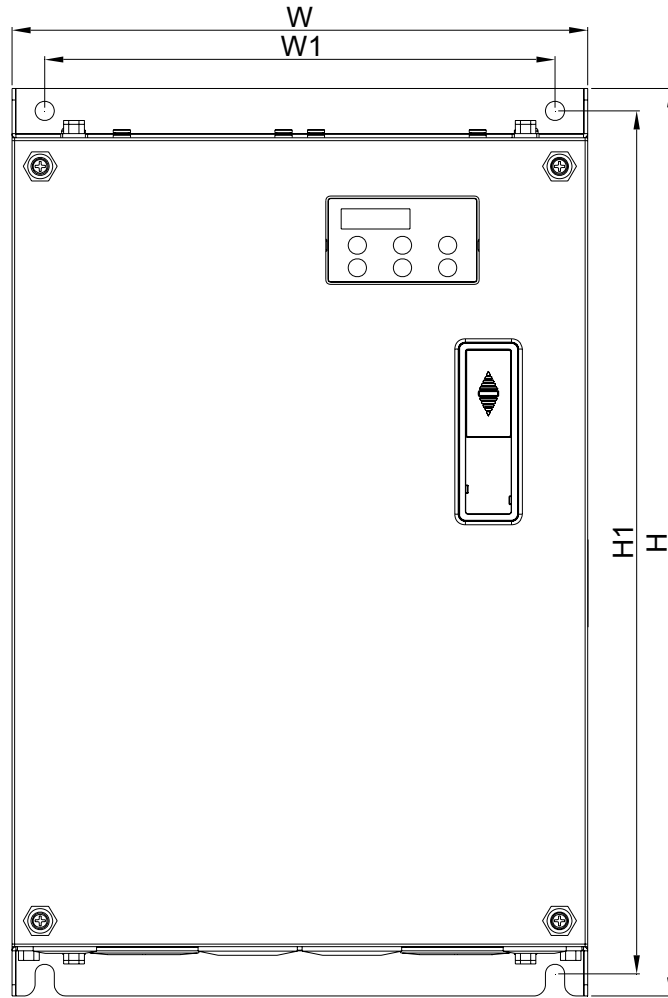

Unit: mm [inch]

Frame No.	W	W1	H	H1	H2	H3	D	Ø	Ø1	Ø2	Ø3
D	255.0 [10.04]	226.0 [8.90]	403.8 [15.90]	384.0 [15.12]	360.0 [14.17]	21.9 [0.86]	168.0 [6.61]	8.5 [0.33]	44 [1.73]	34 [1.34]	22 [0.87]

NOTE

Frame No. D: IED150A23A/43A, IED185A23A/43A, IED220A23A/43A,

Frame No. E

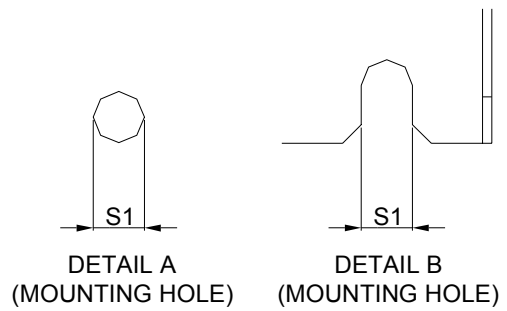
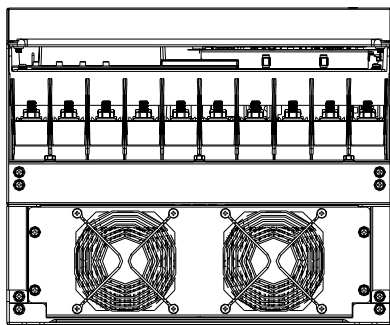
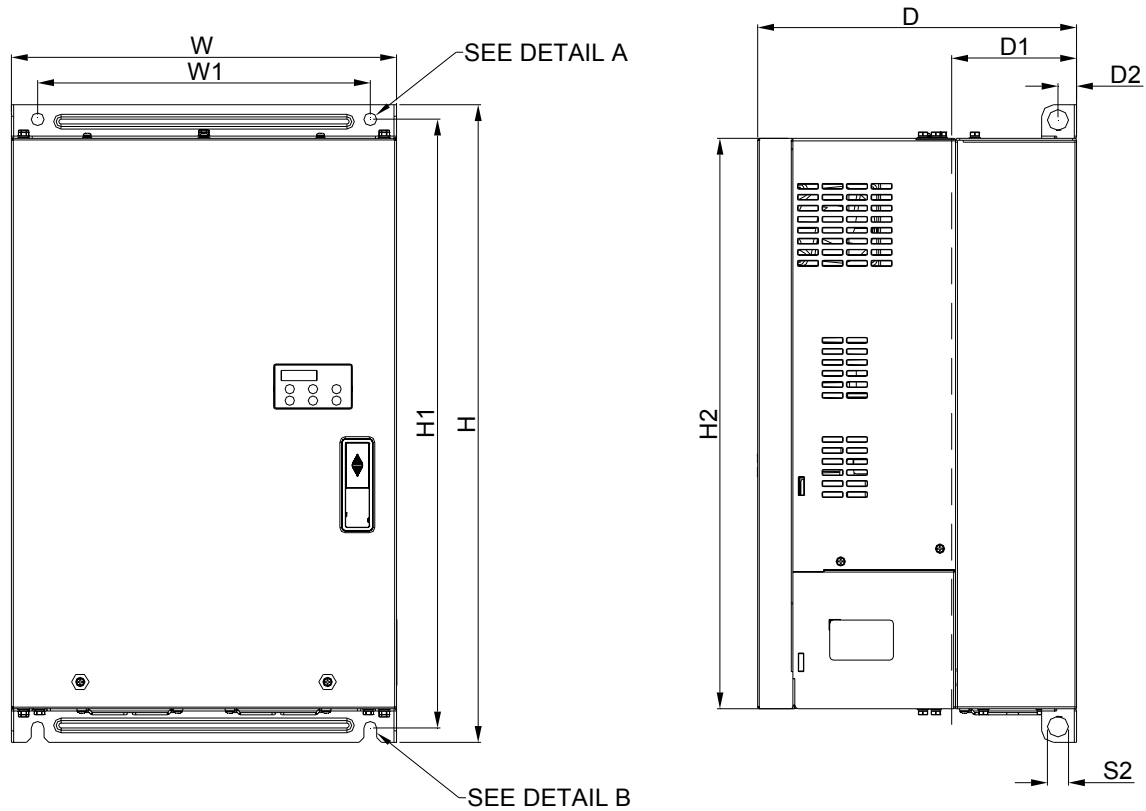



Unit: mm [inch]

Frame No.	W	W1	H	H1	H2	D	D1:	D2:	S1	S2	S3
E1	370.0 [14.57]	335.0 [13.19]	550.0 [21.65]	589.0 [23.19]	560.0 [22.05]	260.0 [10.24]	132.5 [5.22]	18.0 [0.71]	13.0 [0.51]	13.0 [0.51]	18.0 [0.71]

NOTE

Frame No. E1: IED300A43A, IED370A43A, IED450A43A,

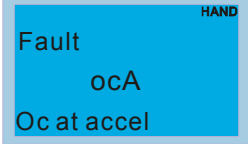
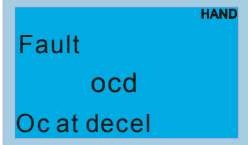
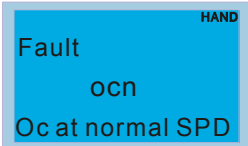
6 Error Codes

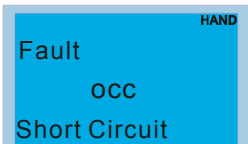
KPED-CE01 Displayed Code	KPED-CE01 Displayed Code	Description of Failure	Solutions
<i>ocA</i>	 Fault ocA Oc at accel	Over current during acceleration	Check if the bolts on the AC motor driver and the motor are loose. Check the connection from U-V-W to the motor for any improper insulation. Increase the acceleration time. Replace with an AC motor driver with a larger output capacity.
<i>ocd</i>	 Fault ocd Oc at decel	Over current during deceleration	Check the connection from U-V-W to the motor for any improper insulation. Increase the deceleration time. Replace with an AC motor driver with a larger output capacity.
<i>ocn</i>	 Fault ocn Oc at normal SPD	Over current during movement	Check the connection from U-V-W to the motor for any improper insulation. Check if the motor is jammed. Replace with an AC motor driver with a larger output capacity.
<i>GFF</i>	 Fault GFF Ground fault	Ground protection is activated. When the AC motor driver detects the output end is grounded and the grounding current is larger than 50% of the AC motor driver's rated current. Note: Such a protection is used for protecting the AC motor driver not for human body.	Check the connection to the motor for short circuit or ground. Make sure if the IGBT power module is damaged. Check the connection at the output side is improperly insulated.
<i>occ</i>	 Fault occ Short Circuit	AC motor driver detects short circuit between the IGBT module's upper and lower bridges.	Return to factory for repair.

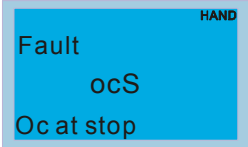
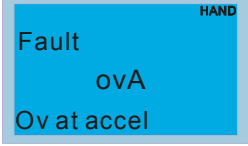
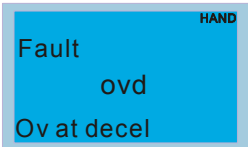
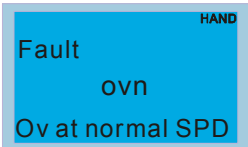
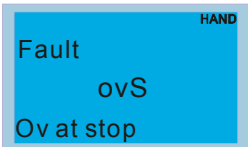
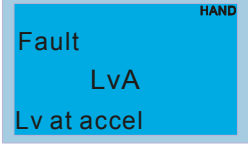
KPED-CE01 Displayed Code	KPED-CE01 Displayed Code	Description of Failure	Solutions
ocS		Over current when the elevator stops. Malfunction of the voltage detection circuit.	Return to factory for repair.
ovA		During acceleration, the AC motor driver detects over current at the internal DC high-voltage side. 230V: 450Vdc ; 460V: 900Vdc.	Check if the input voltage is within the AC motor driver's rated voltage range; and monitor if there is any voltage surge. If the voltage surge due to the motor's inertia causes over-voltage at the AC motor driver's internal DC high-voltage side, please increase the deceleration time or install a brake resistor (optional).
ovd		During deceleration, the AC motor driver detects over current at the internal DC high-voltage side. 230V: 450Vdc; 460V: 900Vdc.	Check if the input voltage is within the AC motor driver's rated voltage range; and monitor if there is any voltage surge. If the voltage surge due to the motor's inertia causes over-voltage at the AC motor driver's internal DC high-voltage side, please increase the deceleration time or install a brake resistor (optional).
ovn		During constant-speed movement, the AC motor driver detects over current at the internal DC high-voltage side. 230V: 450Vdc ; 460V: 900Vdc.	Check if the input voltage is within the AC motor driver's rated voltage range; and monitor if there is any voltage surge. If the voltage surge due to the motor's inertia causes over-voltage at the AC motor driver's internal DC high-voltage side, please increase the deceleration time or install a brake resistor (optional).
ovS		Over-voltage when the elevator stops. Malfunction of the voltage detection circuit	Check if the input voltage is within the AC motor driver's rated voltage range; and monitor if there is any voltage surge.
LvA		During acceleration, the AC motor driver detects that the voltage at the internal DC high-voltage side is lower than the setting of Parameter 11-03.	Check if the voltage of the input power supply is normal. Check if there is any sudden heavy load.

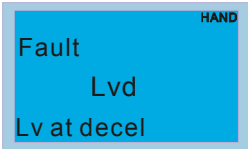
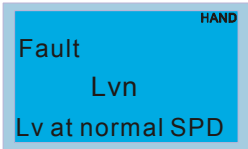
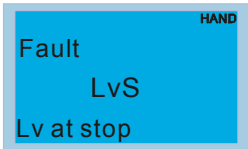
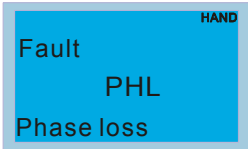
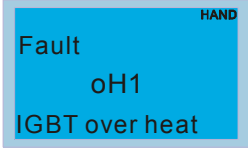
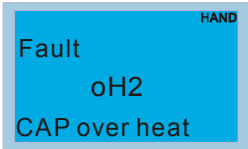
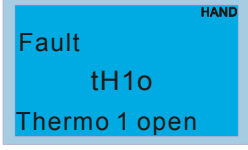
KPED-CE01 Displayed Code	KPED-CE01 Displayed Code	Description of Failure	Solutions
Lvd		During deceleration, the AC motor driver detects that the voltage at the internal DC high-voltage side is lower than the setting of Parameter 11-03.	Check if the voltage of the input power supply is normal. Check if there is any sudden heavy load.
Lvn		During constant-speed movement, the AC motor driver detects that the voltage at the internal DC high-voltage side is lower than the setting of Parameter 11-03.	Check if the voltage of the input power supply is normal. Check if there is any sudden heavy load.
Lvs		When the elevator stops, the AC motor driver detects that the voltage at the internal DC high-voltage side is lower than the setting of Parameter 11-03.	Check if the voltage of the input power supply is normal. Check if there is any sudden heavy load.
PHL		Phase loss protection	Check if the single-phase input is used for the three-phase model or there is any phase loss.
oH1		AC motor driver detects overheat of the IGBT with a temperature higher than the protection level 1 ~ 15HP: 90°C 20 ~ 100HP: 100°C	Check if the ambient temperature is too high. Check if the heat dissipation plate for any external objects. Check if the fan is running. Check if the AC motor driver has sufficient space.
oH2		AC motor driver detects overheat of the IGBT with a temperature higher than the protection level (90°C)	Check if the ambient temperature is too high. Check if the heat dissipation plate for any external objects. Check if the fan is running. Check if the AC motor driver has sufficient space.
tH1o		IGBT temperature sensing circuit has malfunction	Return to factory for repair.

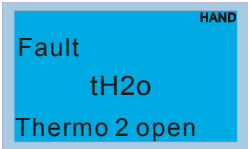
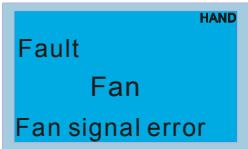
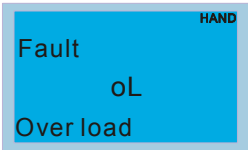
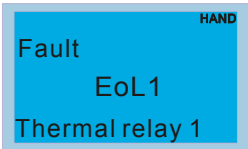
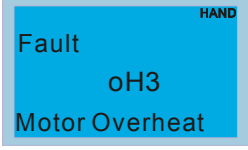
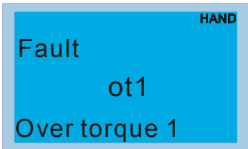
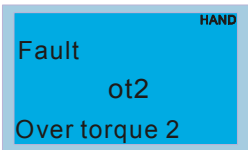
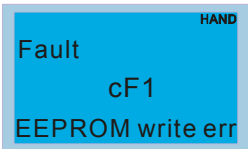
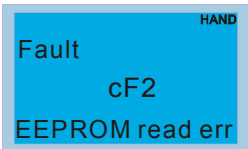
KPED-CE01 Displayed Code	KPED-CE01 Displayed Code	Description of Failure	Solutions
tH2o		Capacitor module temperature sensing circuit has malfunction	Return to factory for repair.
FAn		Fan has a malfunction.	Check if the fan is blocked. Return to factory for repair.
oL		The output current is higher than the withstand current of the AC motor driver.	Check if the motor is overloaded. Increase the output capacity of the AC motor driver.
EoL1		Electronic thermally actuated relay 1 protection is activated	Check if Motor 1 is overloaded. Check if the (02-01) motor's rated current setting is proper.
oH3		AC motor driver detects internal overheat which is higher than the protection level (11-08 PTC level)	Check if the motor is jammed. Check if the ambient temperature is too high. Increase the motor's capacity.
ot1		Electronic thermally actuated relay 1 protection is activated	Check if the motor is overloaded. Check if the (02-01) motor's rated current setting is proper. Increase the motor's capacity.
ot2		Electronic thermally actuated relay 2 protection is activated.	Check if the motor is overloaded. Check if the (02-01) motor's rated current setting is proper. Increase the motor's capacity.
cF1		Memory write error.	Press the RESET button to reset the parameters to factory defaults. If this method is not working, return to factory for repair.
cF2		Memory read error.	Press the RESET button to reset the parameters to factory defaults. If this method neither is nor working, return to factory for repair.

KPED-CE01 Displayed Code	KPED-CE01 Displayed Code	Description of Failure	Solutions
<i>cd0</i>	Fault cd0 las sensor err	Current detection circuit error.	After re-connecting the power supply, if the error still exists, return to factory for repair.
<i>cd1</i>	Fault cd1 las sensor err	U-phase current detection error.	After re-connecting the power supply, if the error still exists, return to factory for repair.
<i>cd2</i>	Fault cd2 lbs sensor err	V-phase current detection error.	After re-connecting the power supply, if the error still exists, return to factory for repair.
<i>cd3</i>	Fault cd3 lcs sensor err	W-phase current detection error.	After re-connecting the power supply, if the error still exists, return to factory for repair.
<i>Hd0</i>	Fault Hd0 cc HW error	cc protection hardware circuit error .	After re-connecting the power supply, if the error still exists, return to factory for repair.
<i>Hd1</i>	Fault Hd1 Oc HW error	oc protection hardware circuit error.	After re-connecting the power supply, if the error still exists, return to factory for repair.
<i>Hd2</i>	Fault Hd2 Ov HW error	ov protection hardware circuit error.	After re-connecting the power supply, if the error still exists, return to factory for repair.
<i>Hd3</i>	Fault Hd3 occ HW error	occ protection hardware circuit error.	After re-connecting the power supply, if the error still exists, return to factory for repair.
<i>AUE</i>	Fault AUE Auto tuning err	Motor parameter auto-tuning error.	Check if the motor's connection is correct. Check if the motor's capacity and the parameter settings are correct. Re-test

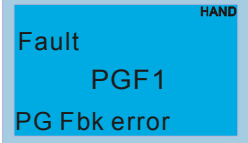
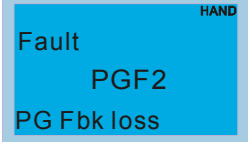
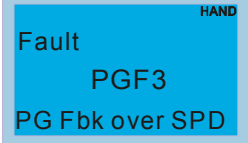
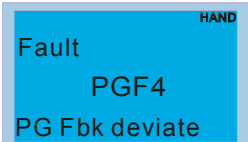
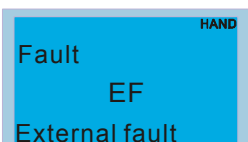
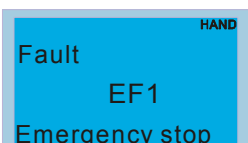
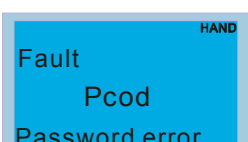
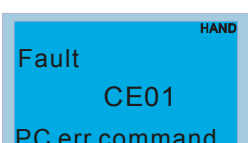
KPED-CE01 Displayed Code	KPED-CE01 Displayed Code	Description of Failure	Solutions
PGF1		PG feedback error	If PG feedback control is enabled, check if the Encoder's parameter setting is correct (02-07≠0).
PGF2		PG feedback is disconnected.	Check the PG feedback connection.
PGF3		PG feedback over speed	Check the PG feedback connection. Check if the PI gain and the acceleration/deceleration settings are proper. Adjust the stall detection parameters (Parameters 11-17 ~ 11-18). Return to factory for repair.
PGF4		PG feedback deviation error.	Check the PG feedback connection. Check if the PI gain and the acceleration/deceleration settings are proper. Adjust the stall detection parameters (Parameters 11-17 ~ 11-18). Return to factory for repair.
EF		When the external EF terminals close, the AC motor driver stops output.	After clearing the cause of the error, press the "RESET" button.
EF1		When the external multi-function input terminals are setting emergency stop, the AC motor driver stops output.	After clearing the cause of the error, press the "RESET" button.
Pcod		Password error for three times.	Refer to the settings of parameters 01-6 ~ 01-07. Please turn off the power, re-start, and then enter the correct password.
CE01		Invalid communication command.	Check if the communication command is correct (the communication command must be 03, 06, 10, and 63).

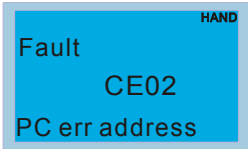
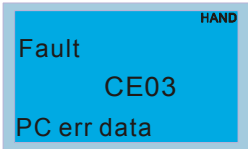
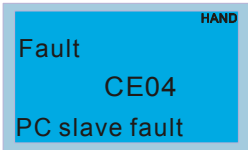
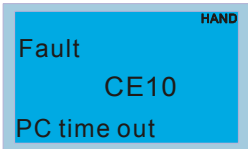
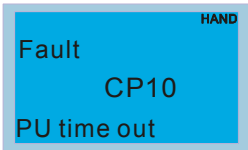
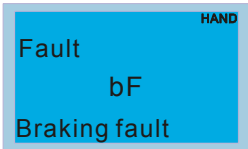
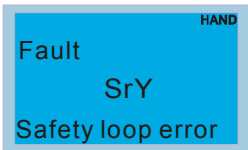
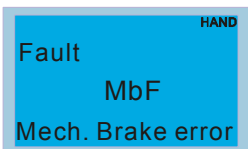
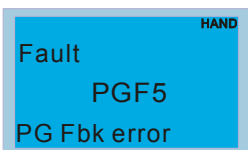
KPED-CE01 Displayed Code	KPED-CE01 Displayed Code	Description of Failure	Solutions
CE02		Invalid communication data address (00H ~ 254H).	Check if communication data length is correct.
CE03		Invalid communication data values.	Check if the communication data values exceed the maximum/minimum values.
CE04		Write data to the read-only address.	Check if the communication address is correct.
CE 10		Communication time-out.	Check if the communication connection is normal.
CP 10		Digital control panel KPVL-CC01 communication time-out.	Check if the communication connection is normal. Check if the digital control unit is working normally.
bF		Driver detects errors from the braking transistor.	After press the RESET button, if the message bF still exists, please return to factory for repair.
SrY		IED safety loop detection error.	Check if the safety loop detection is selected correctly (SW3). Check if the IED safety loop is installed correctly (J8). Check if the output operation is normal.
MbF		Mechanical brake feedback signal does not match the release signal.	Make sure if the mechanical brake signal is correct. Make sure if the mechanical brake operation detection time (11-00) is configured correctly.
PGF5		PG hardware detection error.	Check the PG feedback connection. After the PG feedback is corrected, if this error message still exists, please return to factory for repair.

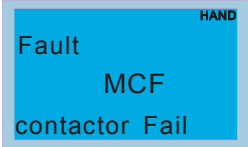
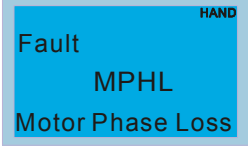
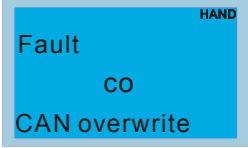
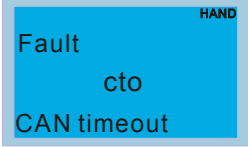
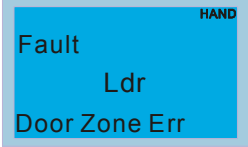
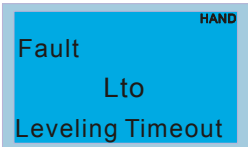
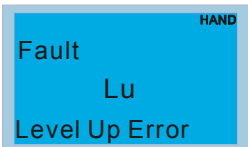
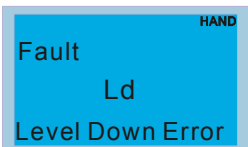
KPED-CE01 Displayed Code	KPED-CE01 Displayed Code	Description of Failure	Solutions
<i>nCF</i>		Solenoid valve actuation signal does not match the release signal.	Make sure if the solenoid valve actuation signal is correct. Make sure if the solenoid valve operation detection time (11-01) is configured correctly.
<i>nPHL</i>		Output phase loss.	Make sure if the connection from the IED to the motor is normal. Return to factory for repair.
<i>CO</i>		CAN communication packet error.	Check if the connection for CAN communication is correct without any noise.
<i>cto</i>		CAN communication time-out.	Check if the connection for CAN communication is correct without any noise.
<i>Ldr</i>		No leveling signal is received at stop. The stop position does not match the value from the hoistway self-learning process.	Check if the leveling signal is normal. Check if the leveling time-out parameter is configured correctly. Check the elevator for possible slip.
<i>Lto</i>		No leveling signal is received for a time longer than the leveling signal time-out setting.	Check if the leveling signal is normal. Check if the leveling time-out parameter is configured correctly. Check the elevator for possible slip.
<i>Lu</i>		Upper leveling signal is not received at stop.	Check if the upper leveling signal is normal. Check if the leveling plate has sufficient length. Check the parking deceleration parameter setting; decrease the deceleration; increase the parking time.
<i>Ld</i>		Down leveling signal is not received at stop.	Check if the lower leveling signal is normal. Check if the leveling plate has sufficient length. Check the parking deceleration parameter setting; decrease the deceleration; increase the parking time.

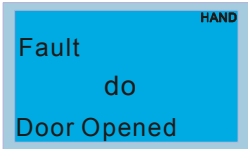
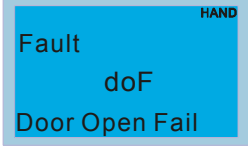
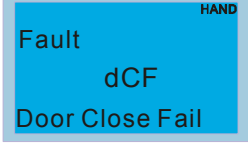
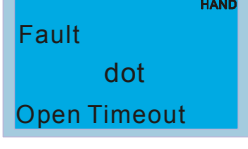
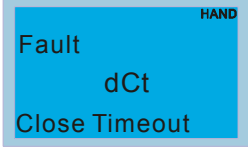
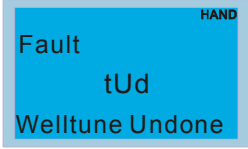
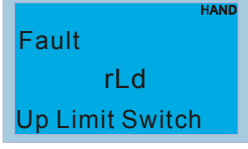
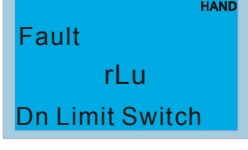
KPED-CE01 Displayed Code	KPED-CE01 Displayed Code	Description of Failure	Solutions
<i>do</i>	 A blue rectangular box with a light blue border. Inside, the text reads "Fault" at the top, "do" in the middle, and "Door Opened" at the bottom. A small "HAND" label is in the top right corner.	Door close limit has malfunction during movement.	Check if the door close limit signal is normal. Check if the communication between the IED and the car-top board is normal.
<i>dof</i>	 A blue rectangular box with a light blue border. Inside, the text reads "Fault" at the top, "doF" in the middle, and "Door Open Fail" at the bottom. A small "HAND" label is in the top right corner.	The automatic re-tries for door open exceed the parameter setting.	
<i>dCF</i>	 A blue rectangular box with a light blue border. Inside, the text reads "Fault" at the top, "dCF" in the middle, and "Door Close Fail" at the bottom. A small "HAND" label is in the top right corner.	The automatic re-tries for door close exceed the parameter setting.	
<i>dot</i>	 A blue rectangular box with a light blue border. Inside, the text reads "Fault" at the top, "dot" in the middle, and "Open Timeout" at the bottom. A small "HAND" label is in the top right corner.	When the door is opening, the door open signal is not received for a time longer than the setting of the parameter 09-08.	Check if the door close limit signal is normal. Check if the door motor is working normally. Check if the communication between the IED and the car-top board is normal.
<i>dCt</i>	 A blue rectangular box with a light blue border. Inside, the text reads "Fault" at the top, "dCt" in the middle, and "Close Timeout" at the bottom. A small "HAND" label is in the top right corner.	When the door is closing, the door close to position signal is not received for a time longer than the setting of the parameter 09-09.	Check if the door close limit signal is normal. Check if the door motor is working normally. Check if the communication between the IED and the car-top board is normal.
<i>tUd</i>	 A blue rectangular box with a light blue border. Inside, the text reads "Fault" at the top, "tUd" in the middle, and "Welltune Undone" at the bottom. A small "HAND" label is in the top right corner.	Hoistway self-learning error.	Re-execute the hoistway self-learning process. Make sure if the hoistway signal is normal.
<i>rLd</i>	 A blue rectangular box with a light blue border. Inside, the text reads "Fault" at the top, "rLd" in the middle, and "Up Limit Switch" at the bottom. A small "HAND" label is in the top right corner.	Upper limit signal is triggered during movement.	Check the elevator for possible slip. Check the corresponding terminals on the IED. Check if the limit switch signal is normal.
<i>rLu</i>	 A blue rectangular box with a light blue border. Inside, the text reads "Fault" at the top, "rLu" in the middle, and "Dn Limit Switch" at the bottom. A small "HAND" label is in the top right corner.	Move down to the lower limit.	Check the elevator for possible slip. Check the corresponding terminals on the IED. Check if the limit switch signal is normal.

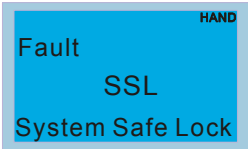
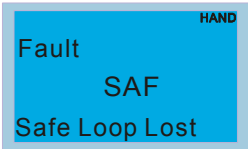
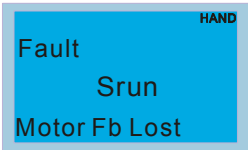
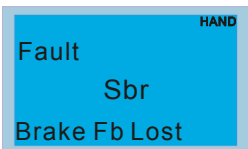
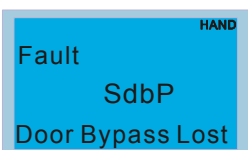
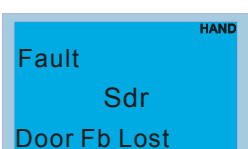
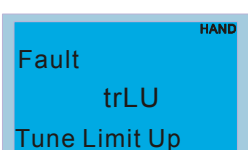
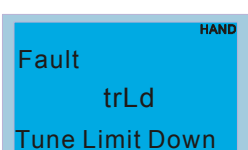
KPED-CE01 Displayed Code	KPED-CE01 Displayed Code	Description of Failure	Solutions
SSL	 Fault SSL System Safe Lock	IED hardware error.	Check if the IED can still work. Return to factory for repair.
SAF	 Fault SAF Safe Loop Lost	Safety loop signal error.	Check if all the switches in the external safety loop are normal.
Srun	 Fault Srun Motor Fb Lost	Output contact feedback signal error	Make sure if the input terminal from the output feedback signal to the IED is normal without any sticking. Make sure if the corresponding relay output is normal.
Sbr	 Fault Sbr Brake Fb Lost	Contracting brake contact feedback signal error.	Make sure if the input terminal from the contracting brake feedback signal to the IED is normal without any sticking. Make sure if the contracting brake relay output is normal.
SdbP	 Fault SdbP Door Bypass Lost	Door open bypass contact feedback signal error.	Make sure if the input terminal from the door open bypass feedback signal to the IED is normal without any sticking. Make sure if the door open bypass relay has normal output.
Sdr	 Fault Sdr Door Fb Lost	Door lock feedback signal error.	Make sure if all the switches in the door lock circuit are normal.
trLU	 Fault trLU Tune Limit Up	Upper limit function is not configured. When the upper limit is valid, both the two leveling signals are valid. The upper limit switch is installed at a too low position.	Make sure if the input function is configured correctly: upper limit switch. Adjust the position of the upper limit switch.
trLd	 Fault trLd Tune Limit Down	Lower limit function is not configured. When the lower limit is valid, both the two leveling signals	Make sure if the input function is configured correctly: lower limit switch. Adjust the position of the lower limit switch.

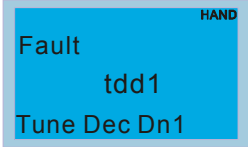
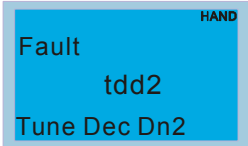
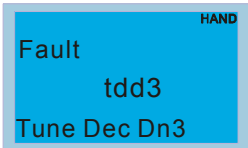
KPED-CE01 Displayed Code	KPED-CE01 Displayed Code	Description of Failure	Solutions
		are valid. The lower limit switch is installed at too high a position.	
tdd1		Coercionary deceleration position is determined from self-learning, but the signal is not received. The signal is triggered several times. The signal is not stable. The sequence of the hoistway signals are not correct; this input function is configured but there is no such switch in the hoistway.	Make sure the switch is installed correctly, and the signal is stably transmitted. Make sure the signal wire is connected to the correct input terminal; check the parameter setting of the multi-function input.
tdd2		Coercionary deceleration position is determined from self-learning, but the signal is not received. The signal is triggered several times. The signal is not stable. The sequence of the hoistway signals are not correct; this input function is configured but there is no such switch in the hoistway.	Make sure the switch is installed correctly, and the signal is stably transmitted. Make sure the signal wire is connected to the correct input terminal; check the parameter setting of the multi-function input.
tdd3		Coercionary deceleration position is determined from self-learning, but the signal is not received. The signal is triggered several times. The signal is not stable. The sequence of the hoistway signals are not correct; this input function is configured but there is no such switch in the hoistway.	Make sure the switch is installed correctly, and the signal is stably transmitted. Make sure the signal wire is connected to the correct input terminal; check the parameter setting of the multi-function input.

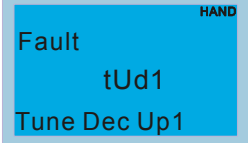
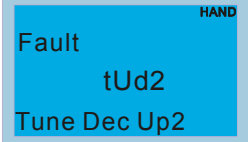
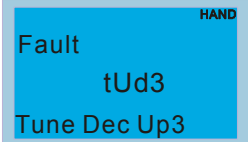
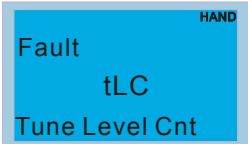
KPED-CE01 Displayed Code	KPED-CE01 Displayed Code	Description of Failure	Solutions
tUd1	 Fault tUd1 Tune Dec Up1	Coercionary deceleration position is determined from self-learning, but the signal is not received. The signal is triggered several times. The signal is not stable. The sequence of the hoistway signals are not correct; this input function is configured but there is no such switch in the hoistway.	Make sure the switch is installed correctly, and the signal is stably transmitted. Make sure the signal wire is connected to the correct input terminal; check the parameter setting of the multi-function input.
tUd2	 Fault tUd2 Tune Dec Up2	Coercionary deceleration position is determined from self-learning, but the signal is not received. The signal is triggered several times. The signal is not stable. The sequence of the hoistway signals are not correct; this input function is configured but there is no such switch in the hoistway.	Make sure the switch is installed correctly, and the signal is stably transmitted. Make sure the signal wire is connected to the correct input terminal; check the parameter setting of the multi-function input.
tUd3	 Fault tUd3 Tune Dec Up3	Coercionary deceleration position is determined from self-learning, but the signal is not received. The signal is triggered several times. The signal is not stable. The sequence of the hoistway signals are not correct; this input function is configured but there is no such switch in the hoistway.	Make sure the switch is installed correctly, and the signal is stably transmitted. Make sure the signal wire is connected to the correct input terminal; check the parameter setting of the multi-function input.
tLC	 Fault tLC Tune Level Cnt	Number of floors does not match the parameter setting.	Make sure the parameter settings, and make sure that the leveling switches/plates are installed correctly.

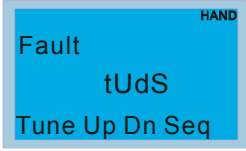
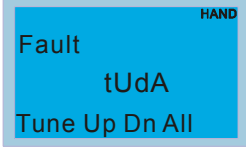
KPED-CE01 Displayed Code	KPED-CE01 Displayed Code	Description of Failure	Solutions
tUdS		Triggering sequence of the leveling switches is not correct.	Make sure that the upper/lower signals are installed to the correct input terminals.
tUdA		Two leveling switches are triggered at the same time.	Make sure that the upper/lower leveling signals are installed to the correct input terminals. Make sure that the two signal wires are not short-circuiting.