

50mm Small Hybrid Recorder

KRN50 Series

USER MANUAL

CE



Thank you for choosing our Autonics products.

Please read the following safety considerations before use.

Preface

Thank you for purchasing Autonics product.





Please familiarize yourself with the information contained in the **Safety Considerations** section before using this product.

This user manual contains information about the product and its proper use, and should be kept in a place where it will be easy to access.

User Manual Guide



- Please familiarize yourself with the information in this manual before using the product.
- This manual provides detailed information on the product's features. It does not offer any guarantee concerning matters beyond the scope of this manual.
- This manual may not be edited or reproduced in either part or whole without permission.
- A user manual is not provided as part of the product package. Visit our web site (www.autonics.com) to download a copy.
- The manual's content may vary depending on changes to the product's software and other unforeseen developments within Autonics, and is subject to change without prior notice. Upgrade notice is provided through out homepage.
- We contrived to describe this manual more easily and correctly. However, if there are any corrections or questions, please notify us these on our homepage.

User Manual Symbols

Symbol	Description
 Note	Supplementary information for a particular feature.
 Warning	Failure to follow instructions can result in serious injury or death.
 Caution	Failure to follow instructions can lead to a minor injury or product damage.
 Ex.	An example of the concerned feature's use.
※1	Annotation mark.

Safety Considerations

- Following these safety considerations will ensure the safe and proper use of the product and help prevent accidents, as well as minimizing possible hazards.
- Safety considerations are categorized as Warnings and Cautions, as defined below:

 Warning	Warning	Failure to follow the instructions may lead to a serious injury or accident.
 Caution	Caution	Failure to follow the instructions may lead to a minor injury or accident.



Warning

- Fail-safe device must be installed when using the unit with machinery that may cause serious injury or substantial economic loss. (e.g. nuclear power control, medical equipment, ships, vehicles, railways, aircraft, combustion apparatus, safety equipment, crime/disaster prevention devices, etc.)
Failure to follow this instruction may result in personal injury, fire, or economic loss.
- The unit must be installed on a device panel before use.
Failure to follow this instruction may result in electric shock.
- Do not connect, repair, or inspect the unit while connected to a power source.
Failure to follow this instruction may result in electric shock.
- Check the terminal numbers before connecting the power source.
Failure to follow this instruction may result in fire or burning the unit.
- Lithium battery is used in the unit. Do not disassemble or burn the unit.
Failure to follow this instruction may result in explosion.
- Do not touch the unit and terminals after cut off the power within 30 sec.
Failure to follow this instruction may result in electric shock.
- Ground F.G. terminal individually and ground cable should be over AWG16 (1.25mm²).
Failure to follow this instruction may result in electric shock.

- Do not insert any objects at the openings of the unit.
Failure to follow this instruction may result in electric shock or personal injury.
- Do not disassemble or modify the unit. Please contact us if necessary.
Failure to follow this instruction may result in personal injury, fire, or economic loss.



Caution

- Do not use the unit outdoors.
Failure to follow this instruction may result in shortening the life cycle of the unit, or electric shock.
- When connecting the power input and relay output cables, use AWG20 (0.05mm²) cables and make sure to tighten the terminal screw bolt above 0.74N·m to 0.90N·m.
Failure to follow this instruction may result in fire due to contact failure.
- Use the unit within the rated specifications.
Failure to follow this instruction may result in shortening the life cycle of the unit, or fire.
- Do not use loads beyond the rated switching capacity of the relay contact.
Failure to follow this instruction may result in insulation failure, contact melt, contact failure, relay broken, or fire.
- When connecting magnet contact as relay contact output load, attach a surge absorber at contact coil.
Failure to follow this instruction may result in product malfunction.
- Do not use water or oil-based detergent when cleaning the unit. Use dry cloth to clean the unit.
Failure to follow this instruction may result in electric shock, or fire.
- Do not use the unit where flammable or explosive gas, humidity, direct sunlight, radiant heat, vibration, or impact may be present.
Failure to follow this instruction may result in fire or explosion.
- Keep dust and wire residue from flowing into the unit.
Failure to follow this instruction may result in fire or product damage.
- Check the polarity before connecting cables.
Failure to follow this instruction may result in fire or explosion.
- Check the polarity of the measurement input contact before wiring the temperature sensor.
Failure to follow this instruction may result in fire or explosion.

- Check the connection diagram of this manual before supplying power. Failure to follow this instruction may result in fire.
- Do not touch terminal during dielectric or insulation resistance test. Failure to follow this instruction may result in electric shock.
- Use insulation transformer and noise filter power for too much noise from the power. Attach noise filter on the grounded panel, etc. Use short cables for noise filter output part and power terminal of the unit. Failure to follow this instruction may result in product damage, malfunction by surge.

Table of Contents	
Preface	iii
User Manual Guide	iv
User Manual Symbols	v
Safety Considerations	vi
Table of Contents	ix
1. Overview	11
1.1 Features	11
1.2 Component and sold separately	12
1.2.1 Components	12
1.2.2 Sold separately.....	13
1.3 Ordering information	14
1.4 Part descriptions	15
2. Specifications	17
2.1 Input type and range	19
3. Dimensions	21
4. Connections	23
5. Installations	25
5.1 Environment	25
5.2 Installation method	26
5.2.1 Panel mounting	26
6. Functions	27
7. General operation and parameter setting menu	29
7.1 Operation mode	29
7.2 Operation procedure	29
7.3 Setting keys	30
7.4 Parameter	33

Table of contents

8. Recording	35
8.1 Recording preparation	35
8.2 Explanation for input function and setup	36
8.2.1 Input type setup	36
8.2.2 Alarm function setup	47
8.2.3 Recording setup	59
8.2.4 Display information function	78
9. Communication	83
9.1 Modbus address map	85
10. Comprehensive device management program (DAQMaster)	91
10.1 Overview	91
10.2 Features	92
10.3 Dedicated function for KRN50	93

1. Overview

1.1 Features

- 50mm thermal transfer method of paper recorder
- Data logger function for recording without paper
- Supports RS485 communication and dedicated communication port to set or monitor parameters in real-time by PC/PLC
- Multi-input with high accuracy 0.2% level (RTD, TC, Voltage, Current (shunt))
- 2-channel simultaneous recording in graphic mode and digital mode
- High visibility and easy setting by LCD dot matrix
- Supports various option I/O function
- Small size (W96×H96×L100 mm), light weight

1.2 Component and sold separately

1.2.1 Components



KRN50

Mounting Bracket
: 2







User manual

Chart paper
: 2Resistance (50Ω)
: 2

Note

Before using KRN50, check the component.
If any component is left out or damaged, contact our company or seller.
Autonics service center: +82-32-820-2356 to 7

1.2.2 Sold separately

SCM-38I (RS232C to RS485 converter)	SCM-US48I (USB to RS485 converter)
 CE 	 CE 
SCM-US (USB to Serial converter)	
 CE 	

**Note**

SCM-38I (RS232C/RS485 converter) and SCM-US48I (USB/RS485 converter) are same appearance.

1.3 Ordering information

KRN50	2	0	0	4	4	0		
							Power supply	
							0	100-240 VAC 50/60 Hz
							1	24VDC
							Option output	
							0	None
							4	RS485 communication output
							Alarm output	
							0	None
							2	Alarm output: 2 ^{※1}
							4	Alarm output: 4 ^{※2}
							CH2 control output	
							0	None
							CH1 control output	
							0	None
							Number of input channels	
							1	1-channel
							2	2-channel
							Item	
							KRN50	Thermal Line Recorder (50 mm)



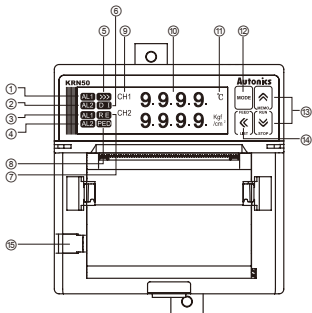

※1. When selecting this for 2 CH model, two alarm outputs for CH1 are available. In other words, you cannot set one for CH1 and one for CH2.

※2. It is selectable only for 2 CH model.

1.4 Part descriptions



- ① CH 1 alarm(AL1) output indicator
: Turns ON when AL1 of input channel 1 operates.
- ② CH 1 alarm(AL2) output indicator
: Turns ON when AL2 of input channel 1 operates.
- ③ CH 2 alarm(AL1) output indicator
: Turns ON when AL1 of input channel 2 operates.
- ④ CH 2 alarm(AL2) output indicator
: Turns ON when AL2 of input channel 2 operates.
- ⑤ Recording run(▶▶▶)/Recording stop(■) indicator
: ▶▶▶ turns ON when start recording (RUN). ■ turns ON when stopping recording (STOP).
- ⑥ Digital input indicator
: Turns ON when setting digital input.
- ⑦ Recording reservation(RE) indicator
: RE turns ON when recording reservation operates.
- ⑧ Recording paper status(PAPER)indicator
: PAPER turns ON if running out of recording paper during recording (RUN).
- ⑨ Channel(CH) display part
: Displays input channel of currently displayed PV on the PV display part.
- ⑩ PV display part
: In RUN mode, displays PV of the current channel.
In setting mode, displays parameters and mode setting values.
- ⑪ Unit display part: Unit of relevant channel is indicated.

- ⑫ **MODE** key: Used to enter setting mode and changing SV mode.
- ⑬   key: Used to move parameters or increase/decrease digits.
 key: Digital memo key,  key: Recording Run/Stop key
- ⑭  key: Used to move parameters to upper group or move digits
Paper feeding key (STOP), printing parameter setting information key (RUN)
- ⑮ PC loader port
: It is a PC loader port for serial communication to set or monitor parameters by PC.
Used to connect SCM-US (USB to Serial converter, sold separately).

2. Specifications

Series		KRN50
Power supply	AC voltage	100-240VAC 50/60Hz
	DC voltage	24VDC
Allowable voltage range	AC voltage	85 to 110% of rated voltage
	DC voltage	90 to 110% of rated voltage
Power consumption	AC voltage	Max. 34VA
	DC voltage	Max. 79W
Display method		LCD dot matrix display (resolution 128×32 Dot)
Input type	RTD	JPt100Ω, DPt100Ω, DPt50Ω, Cu100Ω, Cu50Ω (5 types)
	TC	K, J, E, T, B, R, S, N, C, G, L, U, PLII (13 types)
	Analog	· Voltage: -50.0-50.0mV, -199.0-200.0mV, -1.000-1.000V, -1.00-10.00V (4 types) · Current: 0.00-20.00mA, 4.00-20.00mA (2 types) ※For current input, connect external 50Ω B class (0.1%) high-accuracy resistor.
Event input	Contact	Input ON: Max. 1kΩ, OFF: Min. 100kΩ
	Non-contact	Input ON: Residual voltage max. 1V, OFF: Leakage current max. 0.05mA
	Outflow current	Approx. 0.3mA
Display accuracy ^{※1}	RTD	At room temperature (25°C±5°C): ±0.2% F.S. ±1-digit
	TC	Out of room temperature: ±0.3% F.S. ±1-digit
	Analog	(TC-K2 has same accuracy within -200 to 1350°C of TC-K1.)
Record accuracy		±0.5% F.S.
Alarm output		CH1 (AL1, AL2), CH2 (AL1, AL2) Relay output (250VAC/30VDC 3A 1a)
Alarm output hysteresis		ON/OFF interval setting for alarm output : 1 to 999-digit variable
Communication output		RS485 communication output (Modbus RTU protocol)
Set method		Setting by front keys
Sampling cycle		500ms/channel×2 channels = 1000 ms
Dielectric strength		2300VAC 50/60Hz for 1 min (charging terminal of the other polarity)
Vibration		0.75mm amplitude at frequency of 10 to 55 Hz (for 1 min) in each X, Y, Z direction for 1 hour
Relay life cycle		Mechanical: Over 5,000,000 operations, Electrical: Over 100,000 operations

Insulation resistance		Over 100MΩ (at 500VDC megger)
Noise immunity		Square shaped noise by noise simulator (pulse width 1 μs) ±2kV
Print	Method	Direct thermal line print
	Resolution	8-dot/mm
	Dots	384-dot/Line
	Life cycle	50km
Record	Graphic mode	· Record speed (recording paper speed) : 10, 30, 60, 120, 240, 480, 960mm/hour · Memo cycle : 30s, 1m, 5m, 10m, 15m, 30m, 1h, 2h, 3h, 4h, 8h, 16h, 24h
	Digital mode	TEXT mode record cycle: 00m 05s to 99m 59s
	Paper	Thermal Direct Receipt Paper (57mm×16m)
	Paper supply method	Clamshell Type
	Language	Korean, English
Environment	Ambient temperature	0 to 50°C, storage: -20 to 60°C
	Ambient humidity	35 to 85%RH, storage: 35 to 85%RH
Approval		CE
Weight ^{※2}		Approx. 700g (approx. 470g)

※1. ○ At room temperature (25°C±5°C)

- Thermocouple J (-200≤T≤100):
(±0.2% F.S. or ±2.7°C, select the higher one) ±1-digit
- Thermocouple R, S, C, G (0≤T≤100):
(±0.2% F.S. or ±5.2°C, select the higher one) ±1-digit
- Thermocouple U, T (-200≤T≤100):
(±0.2% F.S. or ±3.5°C, select the higher one) ±1-digit
- Thermocouple U, T (-100≤T≤400):
(±0.2% F.S. or ±2.5°C, select the higher one) ±1-digit
- Thermocouple B type, below 400°C:
There is no accuracy standards.
- All thermocouples, below -100°C: (±0.4% F.S.) ±1-digit

※2. The weight includes packaging. The weight in parenthesis is for unit only.

※Environment resistance is rated at no freezing or condensation.

2.1 Input type and range

Input type		Dot	Display	Input range(°C)	Input range(°F)
Thermocouple	K(CA)	1	TC-K1	-200 to 1350	-328 to 2462
		0.1	TC-K2	-199.9 to 999.9	-199.9 to 999.9
	J(IC)	1	TC-J1	-200 to 800	-328 to 1472
		0.1	TC-J2	-199.9 to 800.0	-199.9 to 999.9
	E(CR)	1	TC-E1	-200 to 800	-328 to 1472
		0.1	TC-E2	-199.9 to 800.0	-199.9 to 999.9
	T(CC)	1	TC-T1	-200 to 400	-328 to 752
		0.1	TC-T2	-199.9 to 400.0	-199.9 to 752.0
	B(PR)	1	TC-B	100 to 1800	212 to 3272
	R(PR)	1	TC-R	0 to 1750	32 to 3182
	S(PR)	1	TC-S	0 to 1750	32 to 3182
	N(NN)	1	TC-N	-200 to 1300	-328 to 2372
	C(TT) ^{※1}	1	TC-C	0 to 2300	32 to 4172
	G(TT) ^{※2}	1	TC-G	0 to 2300	32 to 4172
	L(IC)	1	TC-L1	-200 to 900	-328 to 1652
		0.1	TC-L2	-199.9 to 900.0	-199.9 to 999.9
	U(CC)	1	TC-U1	-200 to 400	-328 to 752
		0.1	TC-U2	-199.9 to 400.0	-199.9 to 752.0
Platinel II	1	TC-P	0 to 1390	32 to 2534	
RTD	Cu50Ω	0.1	CU50	-199.9 to 200.0	-199.9 to 392.0
	Cu100Ω	0.1	CU100	-199.9 to 200.0	-199.9 to 392.0
	JPt100Ω	1	JPT1	-200 to 600	-328 to 1112
		0.1	JPT2	-199.9 to 600.0	-199.9 to 999.9
	DPT50Ω	0.1	DPT50	-199.9 to 600.0	-199.9 to 999.9
	DPT100Ω	1	DPT1	-200 to 600	-328 to 1112
0.1		DPT2	-199.9 to 600.0	-199.9 to 999.9	
Analog	Voltage	-50.0 - 50.0mV		50mV	-1999 to 9999 (display range depends on the decimal point position)
		-199.9 - 200.0mV		200mV	
		-1.000 - 1.000V		1V	
		-1.00 - 10.00V		10V	
	Current (shunt)	0 - 20mA		0-20	
		4 - 20mA		4-20	

※1. C(TT): Same as existing W5(TT).

※2. G(TT): Same as existing W(TT).

3. Dimensions

(unit: mm)

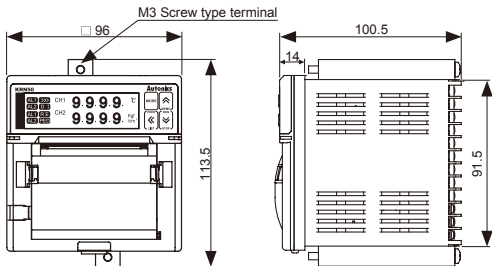

- Panel cut-out

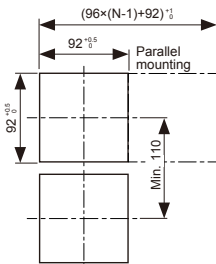

- N = Quantity

- Panel thickness: 1 to 4 mm

4. Connections

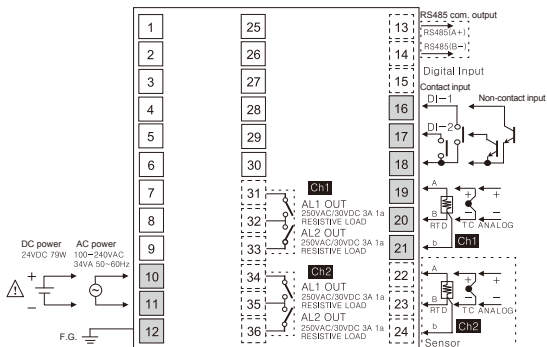

- ※ Shaded terminals are for the standard model. (power terminal, CH1 input terminal, DI input terminal)
- ※ Dot line terminals are for the option model. (CH2 input terminal, alarm output terminal, communication output terminal)
- ※ The DC power model does not have F.G.
- ※ When using 2-wire RTD, short B and b terminals.
- ※ For current input, external 50Ω B class (0.1%) high-accuracy resistor.

5. Installations

5.1 Environment

Install this unit in place where the below conditions are satisfied.

- Panel mounting
This recorder is panel mounting type.
- Place where ventilation is well
To prevent from malfunction and damage by overheating (use temperature range: 0 to 50°C), install this unit where ventilation is well.
In case installing several KRN50, space each other by panel cut-out.
- Place where vibration is not severe
If there is too much vibration, it may cause malfunction such as print error.
- In case of temperature measurement with thermocouple temperature sensor at the place where temperature is fluctuated, data error may occur. You should warm-up this unit over 30 min to acquire accurate data before using it.
- At the place where temperature and humidity is fluctuated excessively, recording paper color may be changed.

5.2 Installation method

5.2.1 Panel mounting

- i. Install KRN50 on the processed panel as panel cut-out diagram. Mount fixing brackets on upper/lower parts.

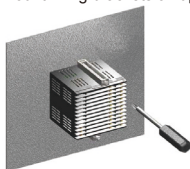

- ii. Tighten fixing brackets on upper/lower parts to fix on the panel with screwdriver (+). (Torque: 0.3N•m)
- iii. Wire cables to the rear terminal block.



Note

If using only 1 channel in case of 2 channel model, please short-circuit the input channel (+, - input) not used in order to prevent from noise influence.

If cable connected with recorder has strong power, it may cause damage to recorder or terminal block.

Input must be installed as far as possible from power line.

Terminal wiring must be divided from high-voltage and high-current power line in order to prevent from electricity failure and self-induction noise. Also please avoid parallel wiring or same wiring with power line.

It may be effective if dividing by means of pipe or duct or using shield cable or twisted-pair cable.

Same compensating wire must be used for precise measurement when thermocouple lead wire need to extend. If not, it may cause an accidental error.

When RTD lead wire need to extend, please use it with small resistance value and be equal for resistive value to 3 lead wires.



Warning

Connect wiring after power off in order to prevent from electric shock.

Check input specifications in order to prevent from any damages.

6. Functions

KRN50 recorder is able to measure Thermocouple, RTD, voltage (1VDC, 10VDC, 50mVDC, 200mVDC), current(DC 0 to 20mA, DC 4 to 20mA) signal by total 2 input channels. Measured signal records by digital and graph type through setting a variety of recording speed.

- Alarm

Input 1 channel can have 2 alarm outputs. Alarm output is operating by a kinds of modes (None, Latch, Stand-by, Latch+Stand-by) through High-limit, Low-limit, Sensor break, Paper end function. Alarm outputs by relay contact.

- Recording

Measured signal records by digital and graph type. Recording speed is able to set by 5sec to 99min 59sec in case of digital mode (Numerical record) and by 10 to 960mm/h in case of graph mode. It has memo function recording data at the necessary time and is able to output time, date, alarm information, error message, parameter list and so on.

- Display

Measured value is indicated by number on LCD display and time, alarm, error information, etc. are displayed.

- Communication function

It is able to use RS-485 communication and communication protocol uses Modbus RTU and communicates with the upper devices, PC or PLC.

- Data backup function (Record Back-up)

It is similar to data logger function. In case of graph mode and 10mm/h recording speed, approx. 10-day-data is able to be saved in EEPROM memory. Therefore user can output the saved data from the memory by graph or digital type. Also even though chart paper is exhausted all, data is able to be saved to the saving space according to recording speed.

- Other functions

Feeding function and recording run/stop function are able to be used by front key or communication at the status of recording stop. Also recording reservation function is able to start or stop recording at the suitable time period user wants.

7. General operation and parameter setting menu

7.1 Operation mode

Recorder has 3 kinds of operation modes.

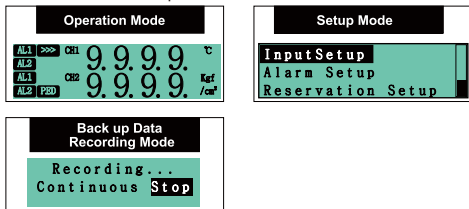

- Common operation mode
This mode operates when normal operation. This mode operates when power on.
- Setting mode
This mode is to set the parameters as like input range, alarm, recording speed, etc. This mode is able to set even if operation does not stop on common operation mode.
- Backup data recording mode (Record backup data recording mode)
This mode is to record the saved data by means of data logger function. It is also unnecessary for operation stop.









7.2 Operation procedure

It is the introduction when this recorder operates initially.

- Ready to record
Put chart paper in paper holder after cutting the glued part (chart paper is installed in recorder as factory default). If necessary, change time and date (they are set as factory default).
- Set input and relevant parameter
Set relevant parameter (input type, alarm, record speed) according to input sensor.
- Record and display measuring value
If necessary, press key for recording Run / Stop. Also mode is able to be changed by measuring value display mode relevant key.

7.3 Setting keys

(1) Enter into the setting mode

- If pressing **MODE** key for 3 sec, it enters into setting mode. After then the upper setting menu refer to as the figure of 7.2 is indicating and the cursor is placed on relevant the upper setting menu. Scroll bar at the right side shows the rest of the setting menu.
- If moving from the upper setting menu to the next step menu, please use ,  key.
- If pressing **MODE** key, it is able to move from the current menu to the lower setting menu. (For moving from the lower setting menu to the upper setting menu, please use  key.)
- If moving from the lower setting menu to the next step menu, please use ,  key.
- If entering into the setting category at the lower setting menu, the cursor flashes on the setting category. Then, user is able to change the setting category by means of  or ,  key.

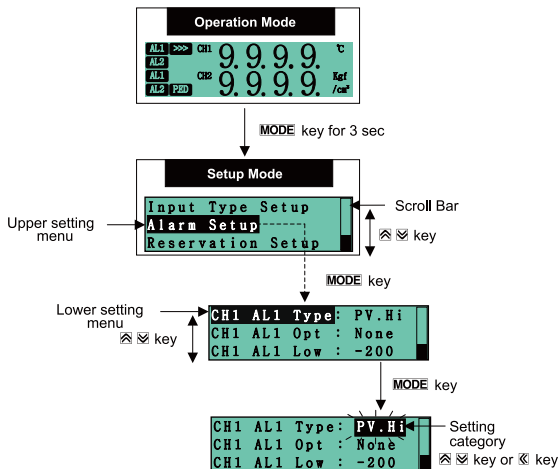

(2) Get out of the setting mode

- If pressing **MODE** key after changing the setting category, setting value is saved and moving to the next lower setting menu.
- The lower setting menu is able to be selected by **⏏**, **⏏** key and if pressing **⏏** key, moving to the upper setting menu.
- If pressing **MODE** key for 3 sec when the cursor is placed at the lower setting menu, it is able to move to the setting mode from general operation mode and operate according to setting value.

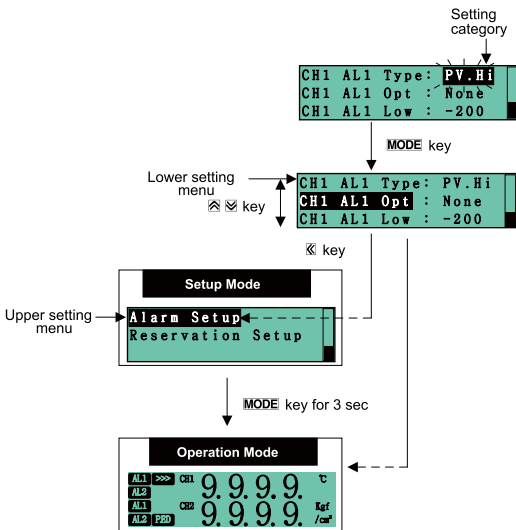

(3) Change the setting category

If pressing **MODE** key after changing the setting category by \leftarrow , \rightarrow key, it is saved and moved to the setting menu.

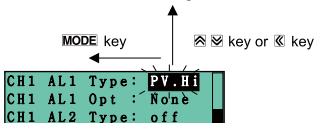
**(4) Insert setting value**

After moving the cursor to the position user wants to the left by \leftarrow key, it is able to change the value by \leftarrow , \rightarrow key. Especially the fourth position of number is able to change to either number or sign.

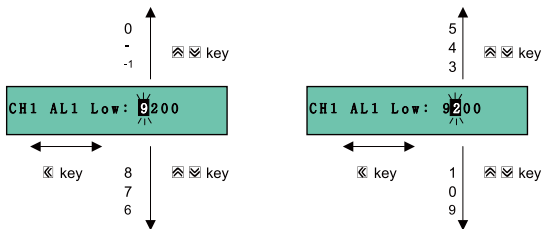

```

CH1 Lo Graph : -200
CH1          : Hi < Lo !!
CH1 In Bias  : 0000
  
```

If pressing **MODE** key at the status of wrong value and save it when changing setting value, it indicates Error code as above.

8. Recording

8.1 Recording preparation

(1) Setting and checking date/time

This function is to set date(Year, Month, Day) and time(Hour, Min, Sec) of recorder. When using recorder at the first time, user must check setting time because recording time follows setting time. When entering into parameter mode according to previous setting time, the entry time is indicated.

(2) Current date [Date]



- Setting range: 00y01m01d to 99y12m31d (unit: -)

Day is set automatically.



(3) Current time [Time]





- Setting range: 00:00:00 to 23:59:59

- Setting date and time

- If pressing **MODE** key for 3 sec, it enters into the upper setting menu.
- If pressing **MODE** key after selecting Date/Time Setup by ,  key, it enters into the lower setting menu from the upper setting menu.

```
Date/Time Setup
Record Backup_data
Environment Setup
```

  key or **MODE** key



- If pressing **MODE** key after moving the cursor to Date by ,  key, it enters into the date setting category. Then if the cursor flashes at the position for change, moving the cursor by  key and setting the value by ,  key. After then if pressing **MODE** key, setting value is saved.

  key

```
Date : 00y01m01d WED
Time : 00h00m00s
```

MODE key



  key or  key

```
Date : 00y01m01d WED
Time : 00h00m00s
```



- Time setting method is same as 3rd.

  key

```
Date : 00y01m01d WED
Time : 00h00m00s
```

MODE key



  key or  key

```
Date : 00y01m01d WED
Time : 00h00m00s
```

8.2 Explanation for input function and setup

8.2.1 Input type setup

(1) CH Using/Recording [CH□ Record]

For Ch1 and Ch2, this function is that user is able to select the channel to use for indicating PV on display and recording to chart paper.

If using/recording the relevant channel, the mode of the relevant channel must be 'On' however if not, it must be 'Off'.

If the mode of any channel is 'Off', this channel is not able to indicate channel indication and PV on display and to record anything.

If the mode of any channel is 'Off', relevant input setting parameter of this channel is not indicated automatically.

- Setting range: On (using/recording) / Off(not using/recording)
- Factory default: Off (unit: -)

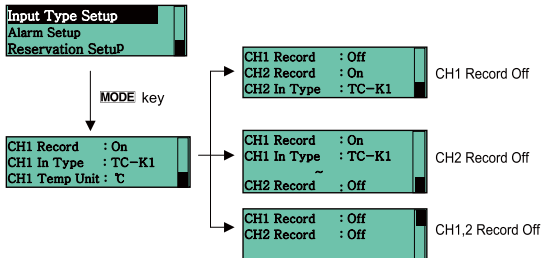

Note

Regarding saved data by record backup, if CH1,2 Record: ON, OFF function is changed, previous record backup data is removed and start saving the data from the current modified time. Therefore please be careful for setup.

(2) Input specifications and range [CH□ In Type]

This recorder has multi input type and user voluntarily is able to select each input type for CH1 and CH2 separately.

(E.g.: set as CH1: DPT1, CH2: TC-K1)

- Setting range: temperature range of each input type and sensor
- Factory default: TC-K1 (unit: -)

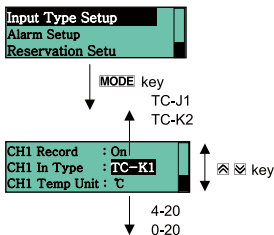
**Note**

If changing input type, saved data by record backup is removed and it starts saving the data from the modified current time. Therefore please be careful for setup.

(3) Temperature unit setting by input type [CH□ Temp Unit]

For temp. sensor input, using temp./indicating temp. unit is able to select to Celsius(°C) or Fahrenheit(°F) voluntarily.

When temp. unit conversion (°C ↔ °F), PV value is changed according to unit conversion table.

In case of analog input type, this parameter [CH□ Temp Unit] is not indicated.

When temp. unit conversion, relevant bias value is initialized and parameter setting value excluding bias value holds previous setting value.

- Setting range: °C / °F
- Factory default: °C (unit: -)

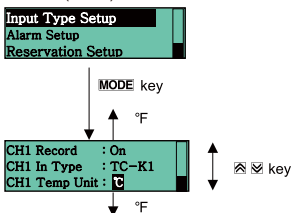
**(4) Graph low-limit scale value [CH□ Lo Graph]**

This function is to set low-limit scale value of graph within input range of each input type.

- Setting range: Min. range by each sensor input type to Graph high limit scale value[CH Hi Graph]- F.S. 5%
- Factory default: -200(unit: Digit)

(5) Graph high-limit scale value [CH□ Hi Graph]

This function is to set high limit scale value of graph within input range of each input type. For analog input type, this parameter is not displayed.

- Setting range: Graph low-limit scale value[CH Lo Graph] + F.S. 5% to Max. range by each sensor input type
- Factory default: 1350(unit: Digit)

Input Type Setup
Alarm Setup
Reservation Setup

↓ MODE key

Lo Graph setup

CH1 Lo Graph	: -200
CH1 Hi Graph	: 1350
CH1 In Bias	: 0000

↑ In case of TC K-1
Setting range : -200 to 1272
⊗ ⊗ key
(Increasing/Decreasing value)

← ⊞ key(Moving the position of number)

Hi Graph setup

CH1 Lo Graph	: -200
CH1 Hi Graph	: 1350
CH1 In Bias	: 0000

↑ In case of TC K-1
Setting range : 1350 to -122
⊗ ⊗ key
(Increasing/Decreasing value)

← ⊞ key(Moving the position of number)

CH1 Lo Graph	: -200
CH1	Hi < Lo !!
CH1 In Bias	: 0000

CH1 Lo Graph	: -200
CH1	Over range !!
CH1 In Bias	: 0000

When High / Low graph setup with wrong value and pressing **MODE** key for save, error message is indicated as above.(Refer to Over Range, Hi < Lo of 8.2.4 Display information function (1) Error) Then if pressing **MODE** key again, it returns to previous value.

Graph high/low scale value setting

**Note**

In case of temp. sensor input (TC, RTD), this function is to set graph scale value for record to chart paper and user voluntarily is able to assign the recording range.

If specified indicating section is recording in detail by graph curve, it is used.

If the recording value exceeds graph high/low-limit scale, it records on empty space of chart paper at the left/right side of graph (approx. 1mm point) as following figure.

In case of the recording start position of digital memo, even though graph high/low-limit scale range is exceeded, actual value is recorded within high/low-limit input range.

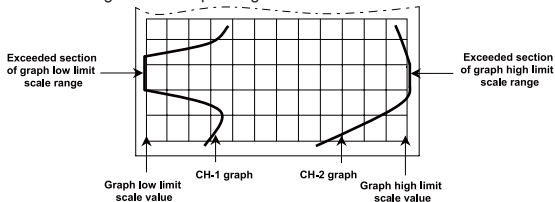

(6) Low-limit input range [CH□ Lo Range]

This function is to assign and limit the actual using low-limit input value within input range.

- Setting range: Min. input range to high-limit input value[CH□ Hi Range]- F.S 5%
- Factory default: Min. input range (unit: -)

(7) High-limit input range [CH□ Hi Range]

This function is to assign and limit the actual using high limit input value within input range.

- Setting range: Low-limit input value[CH□ Lo Range]+ F.S 10% to max. input range
- Factory default: Max. input range (unit: -)

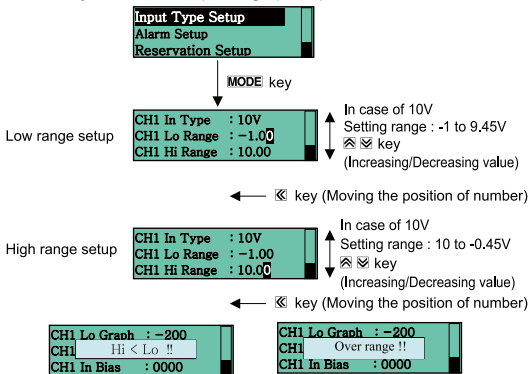

When High / Low graph setup with wrong value and pressing **MODE** key for save, error message is indicated as above.

**Note**

Analog input/scale setting

In case of analog input type (Voltage, Current input), user is able to assign input range (High/Low-limit input value) and this function is to support proper indication for user environment through scale value for assigned input range (High/Low-limit input value) setup.

Graph scale of chart paper is applied one-to-one according to setting scale value (High/Low-limit scale value). (E.g.: in case of -1 to 10V input type, to process from 0 to 5V input, set low-limit input value:0, high-limit input value:5.)

(8) Low-limit scale display value [CH□ Lo Scale]

In case of analog input type, this function is to set low-limit scale value for assigned low-limit input value.

- Setting range: Within F.S. range (-1999 to 9999/-199.9 to 999.9/-19.99 to 99.99/-1.999 to 9.999)
- Factory default: 0.0 (unit: Digit)

(9) High-limit scale display value CH□ Hi Scale]

In case of analog input type, this function is to set high-limit scale value for assigned high limit input value.

If assigned high/low-limit input value is 0V to 5V and user needs -100 to 100 value, user must set low-limit scale value: -100, high limit scale value: 100. When input value is 0V, PV displays -100. If input value is 5V, PV displays 100.)

- Setting range: Within F.S. range(-1999 to 9999/-199.9 to 999.9/-19.99 to 99.99/-1.999 to 9.999)
- Factory default: 100.0 (unit: Digit)

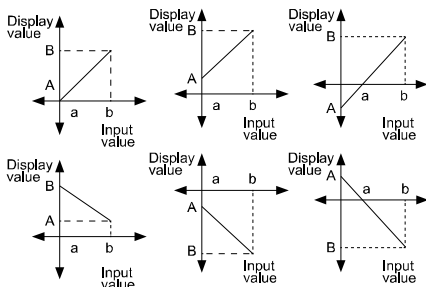
**Note**

Display scale function is able to change display value for max./min. measured input by setting high-limit scale [Hi Scale] and low-limit scale [Lo Scale].

High-limit scale value and Low-limit scale value setting (in case of input range 0-10V)

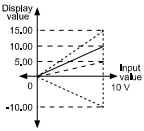
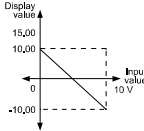
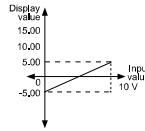
Lo Scale = 0.00 Hi Scale = 5.00, 10.00, 15.00, -10.00	Lo Scale = 10.00 Hi Scale = -10.00	Lo Scale = -5.00 Hi Scale = 5.00
		

When changing input type, high/low scale is changed as factory default.

(10) Scale dot position [CH□ Sc Point]

It is able to change decimal point position for high/low-limit scale value. It changes decimal point position of display value (PV and SV, etc).

- Setting range: 0 / 0.0 / 0.00 / 0.000
- Factory default: 0.0(unit: -)



Note

In case of analog input and changing input type [CH□ In Type], scale value will be initialized to factory default.

If scale value for analog input is changed when input type [CH□ In Type] setup, previous record backup data is removed (Backup data time initialization) and start saving the data from the current modified time. Therefore please be careful for setup.

(11) Record display unit [CH□ Dp Unit]

This function is to set the unit for record and display.

If only input type parameter [CH□ In Type] is analog input, it is indicated.

In case of analog input unit setup, it is different with temp. sensor therefore PV conversion according to unit conversion is not operated.

In case of temp. sensor input model, it is related with temp. unit setup function therefore this parameter [CH□ DP Unit] is not indicated.

us0 to us9 is used to apply user font unit with 16×16 size (32byte) font.

User font unit is written through RS485 communication.

(Communication program, DAQMaster, has user unit setup and download function.)

- Setting range:

Display unit	°C	°F	%	ppm	V	mV	mA	Pa	kPa	pH
Parameter	°C	°F	%	ppm	V	mV	mA	Pa	kPa	pH

Display unit	psi	kgf/cm ²	m ³ /h	mmHg	mmH ₂ O	us0 to us9	Not indicated
Parameter	psi	kgf	m/h	mmHg	mmH ₂ O	using with adding user unit	OFF

- Factory default: % (unit: -)

Input Type Setup
Alarm Setup
Reservation Setup

↓ MODE key

Low scale setup

CH1 Hi Range	:10.00
CH1 Lo Scale	:000.0
CH1 Hi Scale	:100.0

Setting range : -1999 to 9999
 ⏏ ⏏ key
 (Increasing/Decreasing value)

← ⏏ key (Moving the position of number)

High scale setup

CH1 Hi Range	:10.00
CH1 Lo Scale	:000.0
CH1 Hi Scale	:100.0

Setting range : -1999 to 9999
 ⏏ ⏏ key
 (Increasing/Decreasing value)

← ⏏ key (Moving the position of number)

Scale point setup

CH1 Sc Point	:0.0
CH1 Dp Unit	:000.0
CH1 In Bias	:100.0

Setting range : 0↔0.0↔0.00
 ↔0.000
 ⏏ ⏏ key
 (Increasing/Decreasing value)

Display unit setup

CH1 Sc Point	:0.0
CH1 Dp Unit	: °C
CH1 In Bias	:000.0

°C↔°F↔%↔ppm↔V↔mV
 ↔mA↔Pa↔kPa↔pH↔ ...
 ⏏ ⏏ key
 (Unit conversion)



Note

When record backup if using total 10 user font units (us0 to us9), recent user font unit is dicated. For example, if previous us0 was # and changed to \$ recently, when data output by record backup, previous data with # unit also records with recent unit \$. Therefore one user font unit (us0 to us9) should be used for several units.

(12) Input correction [CH□ In Bias]

This function is to compensate an accidental error occurring by TC, RTD or analog input excluding product allowable error.

If sensor is not able to connect with the position of additional measuring object, this function is to be compensated through calculation of the temperature deviation value between the temperature of sensor connected position and the measuring object temp.

If applying input correction after measuring accidental error value for each sensor, it is able to measure temperature more precisely.

When using input bias function, accidental error value should be measured and if measured accidental error value is not precise, it will be larger.

Each channel is able to set for input bias. (CH1 In Bias, CH2 In Bias)
In case of TC or RTD, if temp. unit conversion °C ↔ °F or input type change, correction value will be initialized to 0. If actual temperature is 80°C, but display indicates 78°C, input correction value [CH□ Input Bias] should be set '2' for indicating 80°C.



↓ MODE key

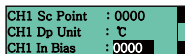

↑ Setting range : -999 to 999
⊞ ⊞ key
↓ (Increasing/Decreasing value)

⊞ key (Moving the position of number)

- Setting range: -999 to 999
In case of TC or RTD input, correction value range is as follows
Temperature sensor range: (-200 to 1350), In Bias: -999 to 999
Temperature sensor range: (-199.9 to 999.9),
In Bias: -99.9 to 99.9
In case of analog input, bias value according to the decimal point of scale point is as following:
Sc Point: 0 In Bias: -999 to 999
Sc Point: 0.0 In Bias: -99.9 to 99.9
Sc Point: 0.00 In Bias: -9.99 to 9.99
Sc Point: 0.000 In Bias: -0.999 to 0.999
- Factory default: 0000 (unit: Digit)

(13) Channel name [CH□ Tag Name]

This function is to set tag name for each channel when recording. However LCD display channel name is fixed to CH1, CH2.

It is to set for each digit (4-digit) in setting range and selected English is always capital letters.



↓ MODE key

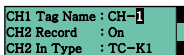

↑ =↔(Blank)↔ . ↔-1↔ -
 ⊞ ⊞ key
 ▼ (Increasing/Decreasing value)

⏏ key (Moving the position of character)

- Setting range: = ↔ (Blank) ↔ . ↔ -1 ↔ - ↔ 0 ↔ 1 ↔ 2 ↔ 3 ↔ 4 ↔ 5 ↔ 6 ↔ 7 ↔ 8 ↔ 9 ↔ A ↔ B ↔ C ↔ D ↔ E ↔ F ↔ G ↔ H ↔ I ↔ J ↔ K ↔ L ↔ M ↔ N ↔ O ↔ P ↔ Q ↔ R ↔ S ↔ T ↔ U ↔ V ↔ W ↔ X ↔ Y ↔ Z ↔ =
- Factory default: CH-□ (unit: -)

8.2.2 Alarm function setup

(1) Alarm output [Alarm Setup]

Alarm output operates when temp. or scale value of object for control is much higher or lower.



When each channel alarm output operation, relevant alarm indicating lamp(CH1=AL1, AL2 CH2=AL1, AL2) on display is lighting.

During recording, when alarm operation, current time, PV, alarm information (AL HI = \uparrow , AL LO = \downarrow , SBA = B, P.End = P) print to chart paper.

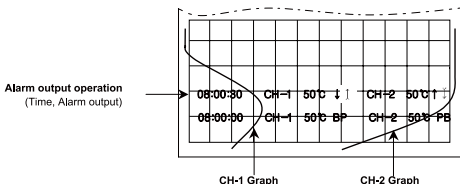
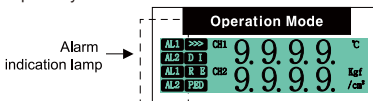
HI, LO of AL1, AL2 in printed AL1($\uparrow\downarrow$)AL2($\uparrow\downarrow$) for classify AL1 and AL2 separately.

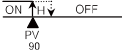
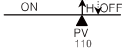

(2) Alarm output operation mode [CH□AL□Type]

Mode	Operation	Descriptions
Off	—	<ul style="list-style-type: none"> None
PV.Hi	 <p>High-limit alarm temp (AL1.H): 90</p>  <p>High-limit alarm temp (AL1.H): 110</p>	<ul style="list-style-type: none"> High-limit alarm PV \geq high limit alarm temperature(AL1.H) , alarm output is ON. Recording mark: AL1=\uparrow AL2=\downarrow
PV.Lo	 <p>Low-limit alarm temp (AL1.L): 90</p>  <p>Low-limit alarm temp (AL1.L): 110</p>	<ul style="list-style-type: none"> Low-limit alarm PV \leq low-limit alarm temperature (AL1.L) , alarm is ON. Recording mark: AL1=\downarrow AL2=\uparrow
SBA	—	<ul style="list-style-type: none"> Sensor Break Alarm When input is not connected or disconnected during recording, alarm output is ON. You can check the input break using external alarm output contact by buzzer or others. Recording mark: AL1= B AL2= B
P.End	—	<ul style="list-style-type: none"> Paper end alarm If running out of recording paper during recording, alarm output is ON. (measured value is saved at system memory) When recording paper is replaced, alarm is cleared automatically (standard alarm) and P is printed on recording paper when printing back up data. Recording mark: AL1= P AL2= P



- Factory default: CH□AL1 Type(PV.Hi), CH□AL2 Type(PV.Lo)

(3) Alarm output option [CH□AL□Opt]

When CH□AL□ Type changes to OFF mode, occurring alarms turns OFF.

Mode	Name	Operation description
None	Standard alarm	If it is an alarm condition, alarm output is ON. Unless an alarm condition, alarm output is OFF.
Latch	Alarm latch ^{※1}	If it is an alarm condition, alarm output is ON. An ON condition is latched. (Holding the alarm output)
StBy ^{※3}	Standby sequence ^{※2}	First alarm condition is ignored. From the second alarm condition, standard alarm operates. When power is ON and it is not an alarm condition, standard alarm operates.
La+St ^{※3}	Alarm latch and standby sequence	If it is an alarm condition, it operates both alarm latch and standby sequence. When power is ON and it is an alarm condition, it is ignored. From the second alarm condition, alarm latch operates.

● Factory default: None (unit: -)

- ※1. If user needs to cancel alarm latch function when current PV is out of the alarm range and when returning from sensor break alarm (SBA) or paper end alarm (P.End), please press + keys for over 3 sec. When PV is higher than alarm value after alarm operation on the status of alarm latch, if alarm mode changes to Standby sequence function or Latch + Standby sequence function, alarm will be OFF.
- ※2. Standby sequence function is applied again if power on or alarm value change.
- ※3. If alarm output operation mode [CH□AL□ Type] is SBA or P.End, it will be not applied and not indicated.

(4) Sensor break alarm [SBA]

If temp. sensor(TC, RTD) is not connected or it is disconnected during temp. control, alarm output will be ON.

Sensor break is able to be checked through buzzer or other devices by means of external alarm contact.

If alarm output operation mode sets to SBA, sensor break alarm will be operated.

※10V input is not applied for SBA.

(5) Paper end alarm [P.End]

During recording, if chart paper is exhausted, recording operation will be stopped and alarm output will be ON.

When chart paper is replaced, alarm will be off automatically. (In case of standard alarm)

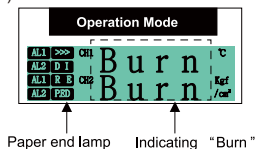
**(6) Alarm temperature [CH□ AL□ Lo], [CH□ AL□ Hi]**

When alarm setting value setup according to relevant alarm output operation mode, alarm output will be operated. According to selection of alarm output operation mode [CH□ AL□ Type], relevant channel parameter [CH□ AL□ Lo], [CH□ AL□ Hi] is interlocked and displayed. When selecting high-limit alarm mode [PV.Hi], only [CH□ AL□ High] is displayed.

When selecting low-limit alarm mode [PV.Lo], only [CH□ AL□ Low] is displayed.

If input type setup [CH□ In Type] is changed, [CH□ AL□ High] or [CH□ AL□ Low] value is changed to input range of input type setup [CH□ In Type] automatically.

If input type is TC or RTD and alarm temp. setup is selected to [CH□ AL□ Low], when burn operate by sensor open, alarm operation will be on.

- Setting range: Within using/display range by input type
- Factory default: [CH□ AL□ Lo]: Low-limit scale value
[CH□ AL□ Hi]: High-limit scale value (unit: °C/°F)

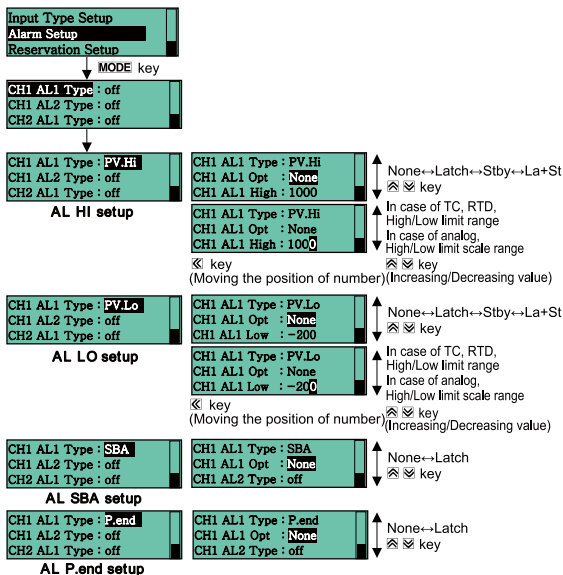

(7) Alarm output hysteresis [CH□ Alarm Hys]

As alarm output hysteresis, 'hysteresis' sets the interval between ON and OFF of alarm output.

- Setting range: 001 to 999 (decimal point is placed same as input decimal point)
- Factory default: 001 (unit: Digit)

(8) High-limit alarm [PV.Hi]

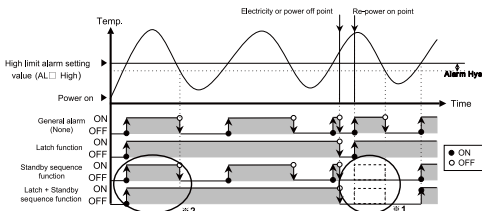

(9) Low-limit alarm [PV.Lo]

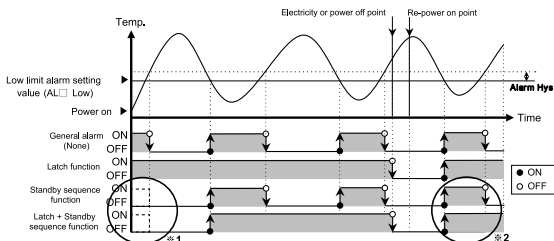

※Standby sequence function

If only alarm output starts within relevant alarm condition range setting PV of the point of time of power on, the first alarm output does not operate and the second alarm output starts operating. (Refer to ※1)

However if alarm output starts out of relevant alarm condition range setting PV of the point of time of power on, the first alarm output starts operating same as general alarm. (Refer to ※2)

Application condition: When power on or changing alarm value, alarm output operation mode, alarm option.

※Alarm latch function

Once alarm output is on, it will hold on even out of alarm output range. (Alarm output hold)

Cancellation condition: If need to cancel alarm latch function, please press $\text{[F]} + \text{[M]}$ key for over 3 sec after current PV is lower than alarm value.

If need to cancel alarm latch function by sensor break alarm(SBA) and paper end(P.End), please press $\text{[F]}+\text{[V]}$ key for over 3 sec after returning from SBA and P.End.

- ※When changing alarm output operation mode. If alarm setting mode [CH□ AL□Type] is changed, alarm setting value [CH□ AL□High, Low] automatically is initialized to maximum value and minimum value.
- ※When changing alarm output option, alarm setting value holds as previously.



Ex.

- Thermocouple Input

For setting mode of channel 1, Input type: TC-K1(-200 to 1350°C), Hi/Lo graph range: 0 to 1000°C. and channel 2: 'Record off'. For alarm function of channel 1, AL1 low-limit: 100°C, Alarm option: None / AL2 high-limit: 600°C, Alarm option: None. For record mode, Record mode: graph mode, Recording speed: 960mm/h, Memo period: 1min. If setup is as above, recording will be as follows.

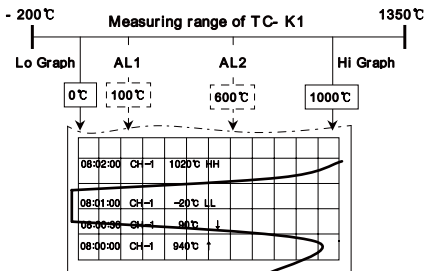

- i. Enter into setting mode
If pressing **MODE** key for 3 sec, it enters into setting mode from operating mode.
- ii. Input type setup
Enter into the lower menu from input type setup, the upper menu, by pressing **MODE** key. If pressing **MODE** key after moving to the lower menu of CH2 record, it enters into the setting category then set to 'Off' and press **MODE** key to get out of this menu. Also after moving to the lower menu of CH1 input type and entering into the setting category, set to 'TC-K1' and press **MODE** key to get out of this menu.

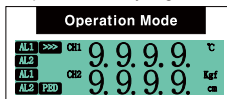

MODE key for 3 sec



- iii. Input High/Low graph range setup
Set CH1 Lo Graph:0, CH1 Hi Graph:1000 at the lower menu of input type setup.

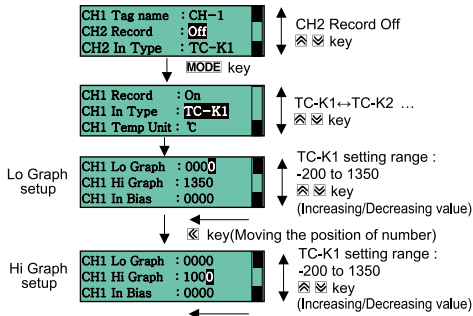

iv. Alarm setup

After moving to the upper menu from the lower menu of input type setup and selecting alarm setup, press **MODE** key to entering into the lower menu.

- v. After setting AL1 type: PV.Hi and saving it by pressing **MODE** key, set AL1 Opt: None, AL1 High: 600.
- vi. After setting AL2 type: PV.Lo and saving it by pressing **MODE** key, set AL2 Opt: None, AL2 Low: 100.

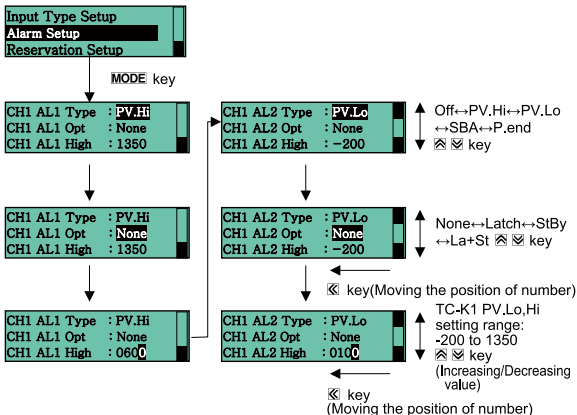

- vii. After moving to the upper menu from the lower menu of alarm setup and selecting record setup, press **MODE** key to entering into the lower menu.
- viii. Set Record mode: Graph, Rec speed: 960mm/h, Memo period: 1min
- ix. After completing all setup, if pressing **MODE** key for 3 sec, it moves to operating mode and processes as above setting value.

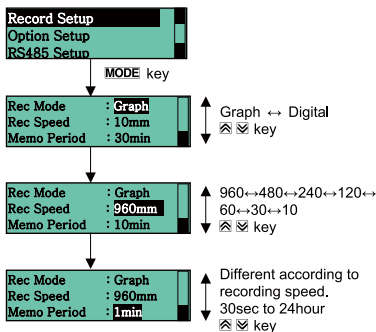

- 4 to 20mA input and unit

For setting mode of channel 2, Input type: 4 to 20mA type, Lo, Hi scale: 0.0 to 100.0, Dp unit: ppm. and channel 1: 'Record off'.

For alarm function of channel 2, AL1 High-limit: 70.0ppm, Alarm option: None / AL2 Low-limit: 20.0ppm, Alarm option: None. For record mode, Record mode: graph mode, Recording speed: 960mm/h, Memo period: 1min (Record mode setup is same as Example 1) If setup is as above, recording will be as follows.

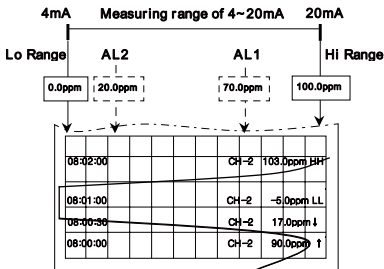

- i. Enter into setting mode
If pressing **MODE** key for 3 sec, it enters into setting mode from operating mode.

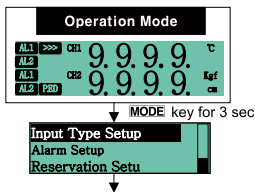

- ii. Input type setup
Enter into the lower menu from input type setup, the upper menu, by pressing **MODE** key. If pressing **MODE** key after moving to the lower menu of CH1 record, it enters into the setting category then set to 'Off' and press **MODE** key to get out of this menu. Also after moving to the lower menu of CH2 input type and entering into the setting category, set to '4 to 20mA' and set CH2 Dp unit to 'ppm' and press **MODE** key to get out of this menu.
- iii. Input High/Low scale setup
Set CH2 Lo Scale:000.0, CH2 Hi Scale:100.0 at the lower menu of input type setup.

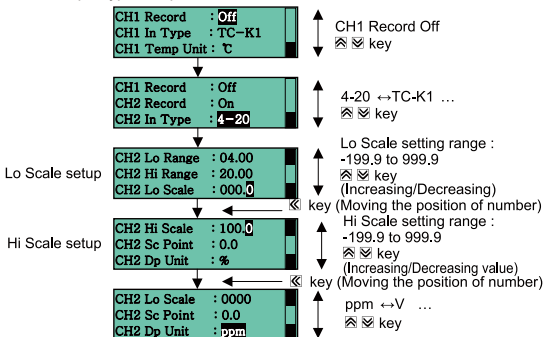

iv. Alarm setup

After moving to the upper menu from the lower menu of input type setup and selecting alarm setup, press **MODE** key to entering into the lower menu.

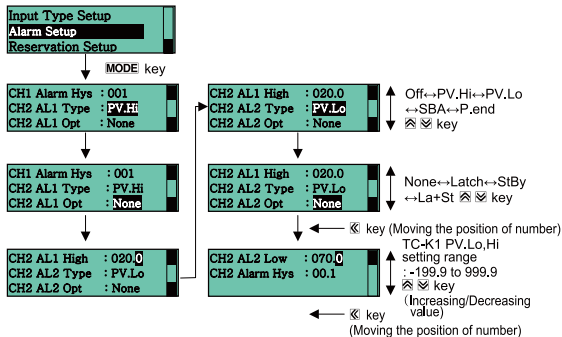
v. After setting CH2 AL1 type: PV.Hi and saving it by pressing **MODE** key, set AL1 Opt: None, AL1 High: 20.0.vi. After setting CH2 AL2 type: PV.Lo and saving it by pressing **MODE** key, set AL2 Opt: None, AL2 Low: 70.0.

8.2.3 Recording setup

(1) Recording run/stop

Once record starts, current PV is printing to chart paper according to setting list print, record mode, speed, language parameter setup.

If pressing  key for over 3 sec, it operates 'Recording Run or Stop' at the basis of current recording state.

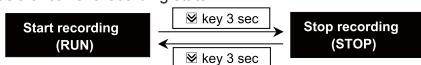

If DI-1 [Digital input 1] parameter sets "Run", it operates "Recording Short / Open" by means of external DI-1 terminals (No.16, 18).

※If using DI-1, front key for recording run/stop does not operate.

When RUN, ">>>" lamp is lightening. When STOP, "■" lamp is

lightening. Once power ON, recording is able to Run or Stop

automatically when re-power ON after electricity failure or by user according to recording run/stop parameter (PWR On State).

(2) Manual paper feeding

If pressing \llcorner key for over 3 sec at STOP state, chart paper is manually able to feed as fixed length (Approx. 10mm). If pressing \llcorner key continuously, chart paper is able to feed as fixed length every 3 sec.

The latest record is placed behind of paper cutter at STOP state therefore cut the chart paper after manual paper feeding in order to check the latest record.

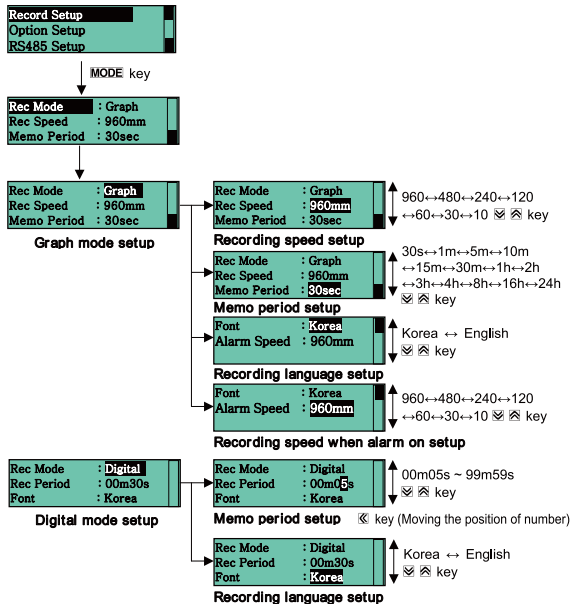

(3) Recording mode

This is to select the recording type to chart paper (Graph mode / Digital mode).

- Setting range: Graph / Digital
- Factory default: Graph (unit: -)

(4) Graph mode

This mode is to record PV on chart paper by curved line graph.

Current date(Year-Month-Day) and high/low-limit scale value for relevant channels are recording every 1 hour.

Current time(hh:mm:ss) and PV for relevant channels are recording according to digital memo period [Memo Period] setup.

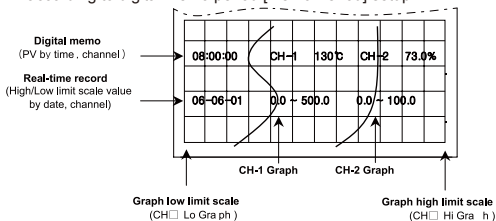

(5) Recording speed (Rec Speed)

This function is to set recording speed and it is able to set by feeding length per hour. If only record mode [Record Mode] is graph mode[Graph], it is indicated.

- Setting range: 10 / 30 / 60 / 120 / 240 / 480 / 960
- Factory default: 10 (unit: mm/h)

(6) Digital memo period (Memo Period)

Recording period for recording current time(hh:mm:ss) and PV for channel to chart paper is set by digital numeric on graph mode as above figure.

Digital memo period is printing at the basis of regular time.

- Setting range: Digital memo period setting range is limited according to recording speed as following table.
- Factory default: 30 (unit: min)(O: enable to set, X: disable to set)

Record speed (mm/h)	Digital memo period						
	None	30 sec	1 min	5 min	10 min	15 min	30 min
10	OFF	X	X	X	X	X	O
30	OFF	X	X	X	O	O	O
60	OFF	X	X	O	O	O	O
120	OFF	X	X	O	O	O	O
240	OFF	X	O	O	O	O	O
480	OFF	X	O	O	O	O	O
960	OFF	O	O	O	O	O	O

Record speed (mm/h)	Digital memo period						
	1 hour	2 hour	3 hour	4 hour	8 hour	16 hour	24 hour
10	O	O	O	O	O	O	O
30	O	O	O	O	O	O	O
60	O	O	O	O	O	O	O
120	O	O	O	O	O	O	O
240	O	O	O	O	O	O	O
480	O	O	O	O	O	O	O
960	O	O	O	O	O	O	O

**Ex.**

If digital memo period is 60 min and recording start time is '09:20', the first digital memo time recording is not '10:20' but '10:00' at the basis of regular time.

Recording time- 10:00 → 11:00 → 12:00 → 13:00 → Until recording end

If digital memo period is 10 min and recording start time is '09:23', the first digital memo time recording is not '09:33' but '09:30' at the basis of regular time.

Recording time- 09:30 → 09:40 → 09:50 → 10:00 → Until recording end

If digital memo period is 15 min and recording start time is '09:34', the first digital memo time recording is not '09:49' but '09:45' at the basis of regular time.

Recording time - 09:45 → 10:00 → 10:15 → 10:30 → 10:45 → Until recording end)

(7) Recording speed for alarm

When alarm on or during alarm latch function, this function is to set recording speed and it is able to check the cause and details of alarm operation.

It is able to check the change rate of PV before and behind alarm in detail because standard recording speed is able to be set faster than before.

If changing recording speed, this parameter is automatically changed same as recording speed.

However digital memo period is same as setting memo period.

- Setting range: 10 / 30 / 60 / 120 / 240 / 480 / 960
- Factory default: 10 (unit: mm)



Note

After recording speed is set differently when alarm on, when user does not realize the change of this parameter setting value, user is able to misunderstand therefore please be aware of this function when using it. Regarding saved data by record backup, if record mode setup function (Rec mode, Rec period, Alarm speed) is changed, previous record backup data is removed(Backup data time initialization) and start saving the data from the current modified time. Therefore please be careful for setup.



Ex.

Recording speed: 240mm/h, Memo period: 5 min, Alarm Speed:960mm/h
In case that alarm does not operate, when recording during per 240mm/h, 5 min, alarm occurs, it records per 960mm/h, 5 min. When alarm occurs and memo period is faster than settable memo period, it changes to the fastest memo period of the enable-to-set among the record speed.

Recording speed: 960mm/h, Memo period: 30 sec, Alarm Speed: 120mm/h

In case that alarm does not operate, when recording during per 960mm/h, 30 sec alarm occurs, it records per 120mm/h, 5 min.

(8) Digital mode

This mode is to record PV on chart paper by numeric and current time, PV for relevant channel are periodically recorded by printing/recording period setup [Rec period].

Current time(Year-Month-Day) and high/low-limit scale value are recorded every 24 hour period on digital mode.

Current PV is recorded through digital memo function by means of front key(☞ key+3sec), DI input terminal(DI-2+1sec) or communication.

00:02:00	CH-1	110℃	CH-2	75.0%
00:03:00	CH-1	110℃	CH-2	75.0%
00:01:00	CH-1	150℃	CH-2	75.0%
09-03-20	0 ~	1000	0 ~	500
23:59:00	CH-1	150℃	CH-2	72.0%
23:58:00	CH-1	120℃	CH-2	70.0%
23:57:00	CH-1	80℃	CH-2	58.0%

(9) Recording/Printing period (Rec Period)

It is to set period(min, sec) recording current date(hh:mm:ss) and PV for relevant channel by digital numeric.

- Setting range: 00m05s to 99m59s
- Factory default: 01m00s (unit: min sec)

(10) Recording language (Font)

This recorder is able to record in Korean and English and current date, high/low-limit scale value and parameter list are recorded by setting language.

- Setting range: Korea / English
- Factory default: Korea (unit: -)



Ex.

Korea: 현재시간 2009년03월19일 12시30분00초

English: DATE 03-19-2009 12:30:00

(11) Reservation recording

After user sets reservation time in advance, recording RUN and STOP automatically according to reservation time setting.

If reservation record parameter is 'On', recording start time and stop time setup parameter is indicated and recording operates according to setting time.

If returning to operating mode after setting reservation function on the setting mode, recording is stopped and the reservation record lamp (RE) is lighting on display.

During reservation record, if re-power on due to electricity failure and the time of re-power on is within reserved time, recording continuously operates but if out of reserved time, recording is stopped.

If parameter sets to 'Off', record start time and stop time are not displayed.

- Setting range: Off(not using reservation recording), On(using reservation recording)
- Factory default: Off



Note

While recording by reservation record setup, recording RUN/STOP function by key+3sec, DI-1 input terminal, communication does not operate however if not, recording RUN/STOP function by key+3sec, DI-1 input terminal, communication is able to operate.

Start time must not be same as stop time and if setting it, "Time Set!!" message will be indicated on display.



Ex.

Record Setup Record Mode: Digital

Record Speed: 5sec

Reservation Setup Start Time: 12:00

Stop Time: 12:02

(Record Start)12:00:00→12:00:05...12:01:55→12:02:00(Record Stop)

(12) Recording start time (Start Time)

Set the recording start time.

- Setting range: 00:00 to 23:59

(13) Recording stop time (Stop Time)

Set the recording stop time.

- Setting range: 00:00 to 23:59

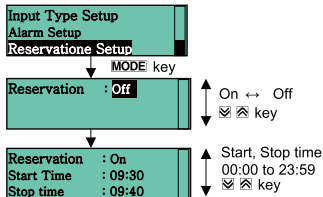

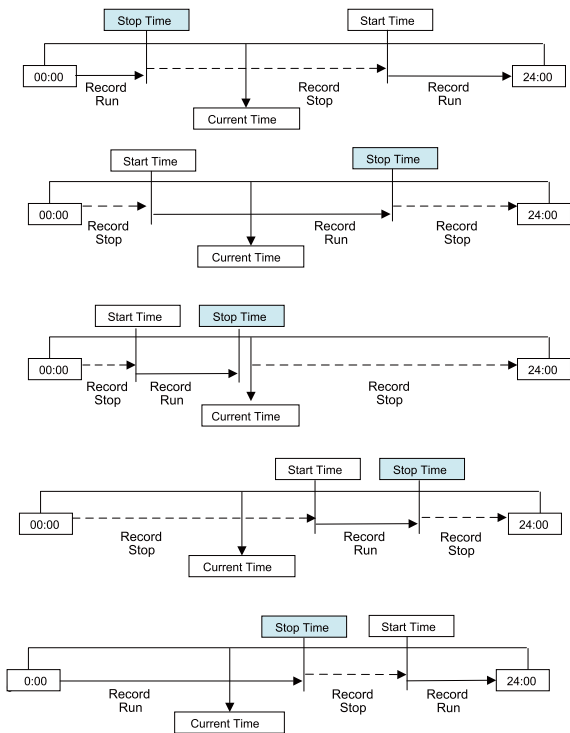

(14) DI-1 function [Digital Input 1]

This function is able to operate recording start by means of external digital input terminals (No.16, 18).

If this mode sets 'Run', recording operates by recording period setup while external digital input terminal is short.

When DI-1 function operates at the first time, recording after current time print as follows.

Korean: 현재시간 2009년03월19일 12시30분00초

English: DATE 03-19-2009 12:30:00

If this mode sets 'Off', no function operation.

- Setting range: Off / Run
- Factory default: Off (unit: -)

**Note**

If using DI-1, front key for recording run/stop does not operate.

While recording by reservation record, DI-1 function is not able to operate and after reservation record stop, this function is able to operate.

(15) DI-2 function [Digital Input 2]

This function is able to operate recording start by means of external digital input terminals (No.17, 18). If this mode sets 'Memo', current time(hh:mm:ss) and PV for relevant channel are recorded at the time of inputting one signal to external digital input terminal.

It is able to operate with Memo function by means of  key+3sec together. If this mode sets 'Off', no function operates.

- Setting range: Off / Memo
- Factory default: Off (unit: -)

**Note**

If applying voltage to terminal no.16 and 17, it may cause damage to input circuit or malfunction.

In case of no relay contact, it needs to use NPN open collector output type contact and in case of relay contact, it needs to use contact small current(0.2mA) is able to be flowed enough.

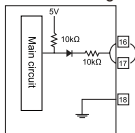

(16) Recording start/stop when power on [PWR On State]

This function is to set operating record when power on simultaneously. It is divided into Run and Stop.

If setting reservation record, the time of power on is reservation record start time but if not, record stop will hold.

- Setting range: Run / Stop
- Factory default: Run (unit: -)

(17) Printing the setting list when record start [RUN On State]

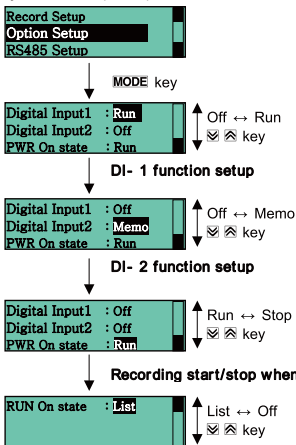

This function is to set printing the setting list when record start simultaneously. It is divided into List and Off.

- Setting range: List / Off
- Factory default: Off(unit: -)



Printing the setting list when record start

(18) Digital memo

If pressing  key for 3 sec during record, current time(hh:mm:ss) and PV for relevant channel are recording by digital numeric to chart paper. (Digital input 2 function is also as memo function, if digital input 2 function is setting on, memo function is able to be used by front key.) - As memo function is only for one input, after pressing  key for 3 sec, memo function operates. In order to operate memo function again, this function must be off and on by  key again.

Digital memo function is able to operate by means of external DI-2 input terminal (No.17, 18).

If input has error 'HHHH', 'LLLL', 'BURN' at the time of operating digital memo, each relevant channel records 'HHHH', 'LLLL', 'BURN'.

(19) Paper end

If chart paper is exhausted during record, recording operation will be stopped and paper end lamp (P.ED) will lighten.



If alarm mode sets to paper end function, P.ED lamp will lighten and alarm output will be on simultaneously.

When changing chart paper, if sensing chart paper, the unrecorded data of since the time of exhausting chart paper is able to be recorded and printed.

(20) Data save, re-recording when chart is exhausted

This function is to record the data of after the time of exhausting chart paper if paper end function operates during run or stop.

It is similar with data logger and recording data is able to be saved in the internal memory of the recorder.

When changing chart paper, the following message is automatically indicated. Then user is able to select by ,  key whether recording the unrecorded data or not.

Record previous data in memory ? All Part Cancel

It records by current setting record mode (Digital mode or Graph mode). Therefore user is not able to change record setup of setting mode on P.End state.

All	Recording/Printing all data saved in memory of from the time of paper end to current time.
Part	Recording/Printing some parts of data saved in memory of from the time of paper end after user sets recording/printing time range (Start time/Stop time).
Cancel	Not recording/printing data in memory and return to operating mode.

- Setting range: All / Part / Cancel (unit: -)
- Factory default: Cancel

If chart paper is exhausted during RUN state, it will be changed to STOP state automatically.

When user changes chart paper, message for re-recording function about unrecorded data is indicated on display and user is able to select the recording range.

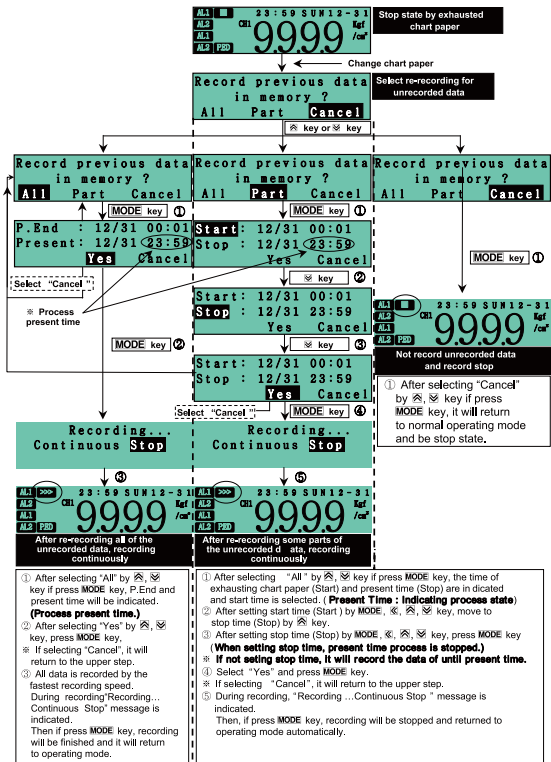

(21) Backup data recording [Rec Backup]

This function is similar to data logger and data is able to be saved in internal memory of recorder.

It is able to print selected all or part of data saved in fixed memory capacity at once. When entering into the setting mode, saving time as start time and stop time is indicated as following figure. Start time means backup start time and stop time means saving time of until present time.

```
Start: 03/09 12:01
Stop : 03/09 12:10
Gra h Di ital Cancel
```

Start time and stop time are fixed to be indicated for selecting favorable time period by user within saved time period on display for backup data saving time as above.

Stop time is fixed to be indicated but saving time continuously updates in recorder.

Therefore if user would like to print backup data after long time standby, printing it after setting to present time for stop time or printing with indicating it on display after cancel and entering into the setting mode again as following figure.

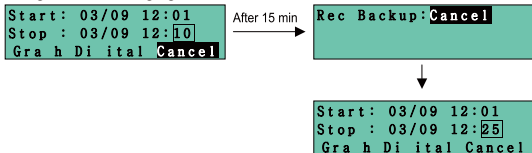

As data saving capacity of this recorder is 18138 ea, saving period is mentioned as next page according to recording mode.

Backup data record applies graph and digital mode. However if backup data is printed by different recording mode from saved recording mode (for example, data is saved by digital mode but printing data by graph mode), print by voluntary recording time (in case of digital mode) or period (in case of graph mode).

If backup data is saved by digital mode, the interval of saving backup data is different according to recording time. (for example, recording time of digital mode is set to 5 min, the interval of saving backup data is every 5 min and stop time is changed every 5 min as well.)

If total record saving time is not passed as figure on the next page, start time is fixed but stop time is updated. However if total record saving time is passed, both start time and stop time are updated since then.

If graph mode, 960mm/h, total saving period is approx. 1 hour 30 min.

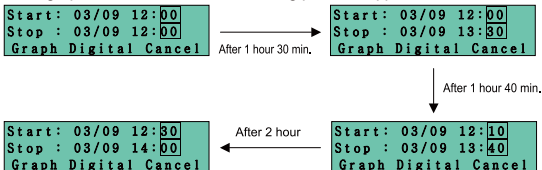

When data print by record backup, reading PV function is only able to be used among communication functions.

When changing setup as following, previous backup data is removed and it starts saving since this time.

Therefore please be careful when setup influenced to record backup data.

Record mode setup: When changing Rec mode, Rec period or Time, Alarm speed setting.

Input type setup: CH1 or 2 Record, CH1 or 2 In type,

When analog input, CH1 or when changing 2 Lo,Hi scale setting

Date/ Time setup: When changing date or time setting

- Setting range: Cancel / Yes (unit: -)
- Factory default: Cancel

Graph Mod Rec Speed	Interval of saving time for 1 data	Total record backup time	
		2 CH mode	1 CH mode
960mm/h	0.5 sec	$11542 \times 0.5 \text{ sec} =$ Approx. 1 hours 30 min	$18138 \times 0.5 \text{ sec} =$ Approx. 2 hours 30 min
480mm/h	1 sec	Approx. 3 hours	Approx. 5 hours
240mm/h	2 sec	Approx. 6 hours	Approx. 10 hours
120mm/h	4 sec	Approx. 12 hours	Approx. 20 hours
60mm/h	8 sec	Approx. 24 hours	Approx. 40 hours
30mm/h	16 sec	Approx. 48 hours	Approx. 80 hours
10mm/h	48 sec	Approx. 6 days (153 hour)	Approx. 10 days (241 hours)
5 sec	5 sec	$11542 \times 5 \text{ sec} =$ Approx. 16 hours	$18138 \times 5 \text{ sec} =$ Approx. 25 hours
1 min	60 sec	Approx. 8 days	Approx. 12 days
to	to	to	to
60 min	3600 sec	Approx. 480 days	Approx. 755 days
to	to	to	to
99 min 59 sec	6000 sec	Approx. 800 days	Approx. 1259 days

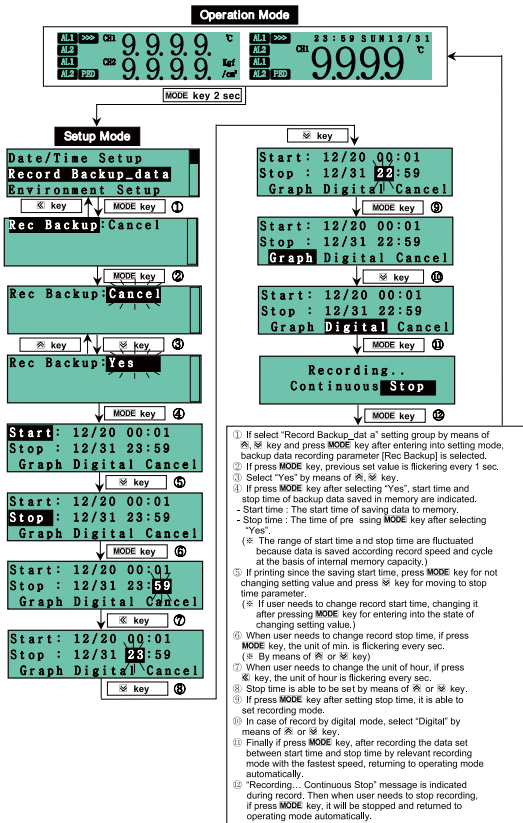

(22) Parameter setting list print

This function is to record setting information of main parameter.
During record, if pressing  key for 3 sec, after recording setting information of each menu, recording PV again.

Record parameter: Tag name, Input, Unit, Range, Scale, Alarm mode, Alarm setting value, Communication function

When starting record, parameter setting information is able to be recorded according to printing the setting list parameter.

현재시간 09년03월10일 12시10분10초	DATE 03-10-2009 12:10:10
※ 파라미터 설정 ※	※ SETUP PARAMETER ※
채널 1	채널 2
채널명칭 TEMP	HUMI
입력사양 TC-K1	mA
표시단위 ℃	%
입력범위 -200~1350	4~20
기록범위 0~400	0~1000
경보1모드 HIGH	HIGH
경보선정값 300	900
경보2모드 LOW	LOW
경보선정값 150	700
통신기능 RS485	Modbus RTU
소형기록계 KRN50 www.autonics.com A/S : 032-820-2356-7	Recorder KRN50 www.autonics.com A/S : 032-820-2356-7

<Korean>

<English>

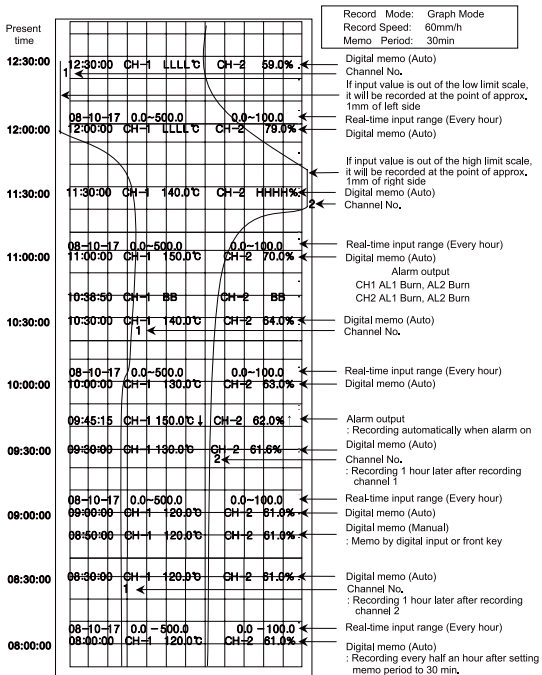

8.2.4 Display information function

(1) Error

This function is to indicate the message for error state.

Message	Descriptions
HHHH	<p>If input value is higher than the input range, it will flash every 0.5 sec. → When input value is within the input range, it will be automatically cancelled.</p> <p>In case of analog input: If full scale(F.S) of input range is within $\pm 10\%$, it will indicate PV only on LCD display and it will record PV with either HH or LL simultaneously as the (a) of following figure. If full scale(F.S) of input range is out of $\pm 10\%$, it will indicate and record HHHH, HH or LLLL, LL as the (b) of following figure. But in case of $H_i < L_o$ setting, it will be indicated oppositely. Therefore in case of 0 to 20mA input and H_i scale=0, L_o scale=100, then if input is out of 20mA, it will indicate LLLL, not HHHH. (In case of 1V analog input, HHHH, LLLL do not operate.) In case of TC, RTD input: After setting H_i, L_o Graph value within sensor temperature range, if PV is out of H_i, L_o Graph value, it will indicate PV only on LCD display and it will record PV with either HH or LL simultaneously as the (c) of following figure. After setting H_i, L_o Graph value same as sensor temperature range, if PV is out of temperature range, it will indicate and record HHHH or LLLL as the (d) of following figure.</p>
LLLL	<p>If input value is lower than the input range, it will flash every 0.5 sec. When input value is within the input range, it will be automatically cancelled.</p> <p>In case of analog or TC, RTD input, indicating will be same as above. (In case of 1V analog input, HHHH, LLLL do not operate.)</p>
BURN	<p>If input except for 10V input is disconnected, it will flash every 0.5 sec. → When input is connected normally, it will be automatically cancelled.</p>
Time Set!!	<p>If time setup is fault for re-recording function by record backup or P.End, it will be indicated. If start time and stop time are same on reservation record function, it will be indicated. If pressing MODE key, it will be cancelled and returned to previous setting state.</p>

Message	Descriptions
Over range!!	When setting HI,LO Graph or range on input type setup, if setting value is out of limit value, it will be indicated. If pressing MODE key, it will be cancelled and returned to previous setting state.
Hi < Lo!!	When setting HI,LO Graph or range on input type setup, if setting value is Hi < Lo or it is not accurate with setting range introducing in this user manual, it will be indicated.(E.g., In case of TC-K1 and -200 to 1350°C, high limit scale value setting range is low-limit scale value + F.S 10% to Max. input range for each sensor, -1350°C to -122.5°C. Then if setting -123°C, "Hi < Lo !!"error message will be indicated.) If pressing MODE key, it will be cancelled and returned to previous setting state.

Relevant channel occurs error operation as above, above message will be indicated by relevant channel turn.

HH or LL message will be indicated when alarm does not operate.

Figure a	→	08:15:00	CH-1	5V	HH	CH-2	5V	HH
Figure b	→	08:25:00	CH-1	HHHH	℃	HH	CH-2	HHHH
Figure c	→	08:15:00	CH-1	170℃	LL	CH-2	170℃	LL
Figure d	→	08:30:00	CH-1	LLLL	℃	LL	CH-2	LLLL

(2) Display indicating mode

In case of 2 channel model, display mode is divided by normal mode (2 channel mode or 1 channel autorotation) and manual mode.

(3) Display normal mode [Display Mode]

2 Channel mode [2CH]: As indicating input value (PV) of 2 channel (CH1 and CH2) simultaneously, if setting display mode to 2 CH on environment setup, PV of CH1 is indicated at the top and PV of CH2 is indicated at the bottom simultaneously.

1 Channel autorotation mode [1CH]: As indicating and rotating 1 channel by periods if setting display mode to 1 CH on environment setup, PV for each channel is automatically rotating and indicating by 2 sec cycle. (Indicating CH1 for 2 sec ↔ CH2 for 2 sec)

If setting one channel record only [Input type setup group >> CH1 or CH2 Record 'Off'], 1 channel display mode is fixed and indicated.

- Setting range: 2CH / 1CH (unit: -)
- Factory default: 2CH

(4) Display manual mode

User is able to select one channel manually by means of $\left[\text{CH1} \right]$ or $\left[\text{CH2} \right]$ key. Display mode conversion method is as follows.

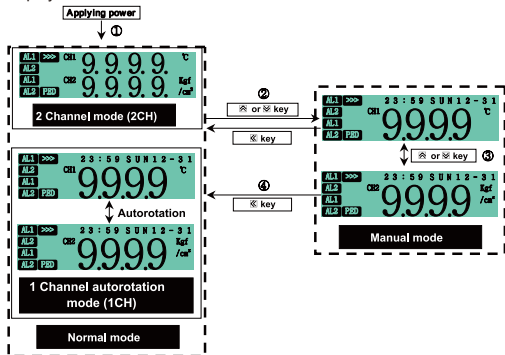

If applying power, it will be indicated by mode setup (2CH or 1CH) on display mode parameter.

When user needs to indicate 1 channel by manual mode, if pressing $\left[\text{CH1} \right]$ or $\left[\text{CH2} \right]$ key, PV of CH1 will be indicated.

Each channel is able to be converted/selected by $\left[\text{CH1} \right]$ or $\left[\text{CH2} \right]$ key. (CH1 ↔ CH2)

If pressing $\left[\text{CLR} \right]$ key on manual mode, it will be converted to normal mode. When applying power or when returning after an electricity failure, it will be indicated by mode setup (2CH or 1CH) on display mode parameter automatically.

(5) LCD backlight

This function is to set LCD backlight type and there are always lightening type and temporary lighting type.

Always lightening type [Always]: It will lighten up during power on.

Temporary lightening type [Temp]: It will lighten up for 30 sec after power on and then automatically light down if no key input.

During light down state, if operating front key, it will lighten automatically.

If no key input for 30 sec after final front key operation, it will light down automatically.

(6) Parameter lock

This function is to restrict checking and changing parameter setting value.

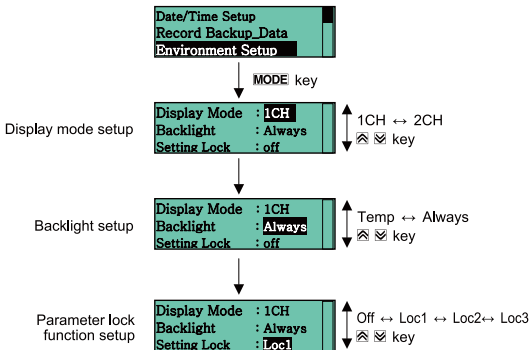

Parameter	OFF	Loc1	Loc2	Loc3
Alarm Setup	●	●	●	◐
Reservation Setup	●	●	◐	○
Input Setup				
Record Setup	●	●	◐	○
Option Setup				
RS485 Setup				
Date/Time Setup				
Record Backup_Data	●	◐	○	○
Environment Setup				

- : Enable to check/set, ◐: Enable to check / disable to set,
- : Disable to check

Even though selecting [Loc1],[Loc2],[Loc3], [Setting Lock] parameters will be always indicated and it will be changed.

- Factory default: Off (unit: -)

**Note**

Even though setting parameter lock function up, parameter will be initialized by parameter initializing function.

(7) Parameter initialization [Parameter Initialize]

This function is to initialize all parameters in memory to factory default value.



If select setting value to “Yes” by \triangle or \square key and press **MODE** key, all parameters will be initialized to factory default value and returned to operating mode. If pressing **MODE** + \square key for 5 sec simultaneously, it will operate.

- Setting range: Yes / No
- Factory default: No (unit: -)

9. Communication



Phone Jack

This function is to set or monitor parameter by external upper system (PC, PLC, etc.) or transmit data to external equipment by communication.

KRN50 recorder is able to communicate through back terminal or front phone jack. In case of back terminal connection.

Front and back communication functions are not used simultaneously. (use autonics SCM-US (sold separately) for communicating by front communication port.)



Note

In case of phone jack communication, there may be reorganization error due to external noise or environment during connecting PC. If error occurs, re-connect the device. Use the phone jack only for setting. Interface

Comm. protocol	Modbus RTU
Connection type	RS485
Application standard	Compliance with EIA RS485
Max. connections	31units (address: 01 to 99)
Comm. synchronous method	Asynchronous
Comm. method	Two-wire half duplex
Comm. distance	Within max. 1 Km
Comm. speed	1200, 2400, 4800, 9600, 19200, 38400, 57600 bps
Comm. respond wait time	0.05 to 0.99sec
Start bit	1-bit (fixed)
Data bit	8-bit (fixed)
Parity bit	None, Odd, Even
Stop bit	1 or 2-bit

Communication setting of KRN50 should be same as upper system. Double setup of communication address at the same line is not allowed. When extending cables and using 1:N multi-drop, it may cause transmission error. Terminal resistor must be used to both end parts of network. (Terminal resistive value: 100 to 120Ω, 1/4W)

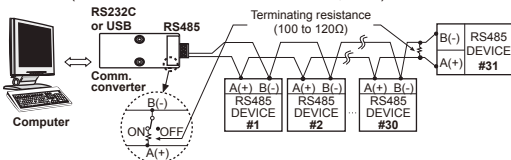

It is recommended to use SCM-US48I (USB to RS485 converter), SCM-38I (RS232C to RS485 converter), SCM-US (USB to Serial converter) of Autonics.



Note

If using the converter not insulated FG and SG for long-distance communication, it may cause KRN50 damage or communication error. It is recommended to use DAQMaster program for monitoring. You can download DAQMaster program and communication manual at our website (www.autonics.com).



Note

For non-communication function models (KRN50-1000-00, KRN50-1002-00, KRN50-2000-00, KRN50-2002-00, KRN50-2004-00), communication is available by front phone jack but there are no communication setup function. Communication setting is fixed as communication speed: 9600bps, communication respond waiting time: 0.05sec, Start bit: 1-bit, Stop bit: 2-bit, Parity bit: None.

9.1 Modbus address map

(1) Alarm output setup group [Alarm Setup]

Parameter	Addr	Description	Setting range	Unit	Default
CH1 AL1 Type	40101	CH1 alarm output1 operation	0: Off, 1: PV.Hi 2: PV.Lo, 3: SBA 4: P.End	—	PV.Hi
CH1 AL1 Opt	40102	CH1 alarm output1 option	0: None, 1: Latch, 2: StBy, 3: La+St	—	None
CH1 AL1 Low ^{※1}	40103	CH1 alarm output1 low-limit SV	Display range by input type	Digit	-200
CH1 AL1 High ^{※1}	40104	CH1 alarm output1 high-limit SV			1350
CH1 AL2 Type	40105	CH1 alarm output2 operation	0: Off, 1: PV.Hi, 2: PV.Lo, 3: SBA, 4: P.End	—	PV.Lo
CH1 AL2 Opt	40106	CH1 alarm output2 option	0: None, 1: Latch, 2: StBy, 3: La+St	—	None
CH1 AL2 Low ^{※1}	40107	CH1 alarm output2 low-limit SV	Display range by input type	Digit	-200
CH1 AL2 High ^{※1}	40108	CH1 alarm output2 high-limit SV			1350
CH1 Alarm Hys	40109	CH1 alarm output hysteresis	001 to 999	Digit	001
CH2 AL1 Type ^{※2}	40110	CH2 alarm output1 operation	0: Off, 1: PV.Hi, 2: PV.Lo, 3: SBA, 4: P.End	—	PV.Hi
CH2 AL1 Opt ^{※2}	40111	CH2 alarm output1 option	0: None 1: Latch 2: StBy 3: La+St	—	None
CH2 AL1 Low ^{※1 ※2}	40112	CH2 alarm output1 low-limit SV	Display range by input type	Digit	-200
CH2 AL1 High ^{※1 ※2}	40113	CH2 alarm output1 high-limit SV			1350
CH2 AL2 Type ^{※2}	40114	CH2 alarm output2 operation	0: Off, 1: PV.Hi, 2: PV.Lo, 3: SBA4: P.End	—	PV.Lo
CH2 AL2 Opt ^{※2}	40115	CH2 alarm output2 option	0: None, 1: Latch, 2: StBy, 3: La+St	—	None
CH2 AL2 Low ^{※1 ※2}	40116	CH2 alarm output2 low-limit SV	Display range by input type	Digit	-200
CH2 AL2 High ^{※1 ※2}	40117	CH2 alarm output2 high-limit SV			1350
CH2 Alarm Hys ^{※2}	40118	CH2 alarm output hysteresis	001 to 999	Digit	001

※It displays only for alarm output models.

※1. It is related with alarm output operation(AL□ Type) parameter setting.

CH□AL□ Type(Off, SBA or P.End): CH□AL□ Low, CH□AL□ High parameters are not displayed.

CH□AL□ Type(PV.Hi): CH□AL□ High parameter is not displayed.

CH□AL□ Type(PV.Lo): CH□AL□ Low parameter is not displayed.

※2. It displays only for 2 channels alarm output model.

(2) Reservation record setup group [Reservation Setup]

Parameter	Addr	Description	Setting range	Unit	Default
Reservation	40070	Reservation ON/OFF	0: OFF, 1: ON	—	Off
Start Time ^{※1}	40071	Start record Hour	00:00 to 23:59	hh:mm	00:00
	40072	Start record Minute			
Stop Time ^{※1}	40073	End record Hour	00:00 to 23:59		00:01
	40074	End record Minute			

※1. This parameters are displayed only when reservation ON/OFF is 'On'.

(3) Input type setup group [Input Type Setup]

Parameter	Addr	Description	Setting range	Unit	Default
CH1 Record	40301	CH1 using/recording	0: USE, 1: NO USE	—	On
CH1 In Type	40302	CH 1 input type	0: TC-K1, 1: TC-K2, 2: TC-J1, 3: TC-J2, 4: TC-E1, 5: TC-E2, 6: TC-T1, 7: TC-T2, 8: TC-B, 9: TC-R, 10: TC-S, 11: TC-N, 12: TC-C, 13: TC-G, 14: TC-L1, 15: TC-L2, 16: TC-U1, 17: TC-U2, 18: TC-P, 19: CU50, 20: CU100, 21: JPT1, 22: JPT2, 23: DPT50, 24: DPT1, 25: DPT2, 26: A.mV1, 27: A.mV2, 28: A-V1, 29: A-V2, 30: A.mA1, 31: A.mA2	—	TC.K1
CH1 Temp Unit ^{※1}	40303	CH 1 temp. unit	0: °C, 1: °F	—	°C
CH1 Lo Graph ^{※1}	40304	CH 1 graph low-limit scale value	※Refer to the 8.2.1 (4), (5)	Digit	-200
CH1 Hi Graph ^{※1}	40305	CH 1 graph high-limit scale value			1350
CH1 Lo Range ^{※2}	40306	CH 1 low-limit input value	※Refer to the 8.2.1 (6), (7)	—	—
CH1 Hi Range ^{※2}	40307	CH 1 high-limit input value			—
—	40308	—	—	—	—
CH1 Lo Scale ^{※2}	40309	CH 1 low-limit scale display value	-1999 to 9999	Digit	000.0
CH1 Hi Scale ^{※2}	40310	CH 1 high-limit scale display value			100.0
CH1 Hi Scale Decimal Point ^{※2}	40311	CH 1 scale dot position	0: 0, 1: 0.0, 2: 0.00, 3: 0.000	—	0.0
CH1 DP Unit ^{※2}	40312	CH 1 record display unit	0: °C, 1: °F, 2: %, 3: ppm, 4: V, 5: mV, 6: mA, 7: Pa, 8: kPa, 9: pH, 10: psi, 11: kgf/cm ² , 12: m ³ /H, 13: mmHg, 14: mmH ₂ O, 15: User1, 16: User2, 17: User3, 18: User4, 19: User5, 20: User6, 21: User7, 22: User8, 23: User9, 24: User0, 25: OFF	—	%

Parameter	Addr	Description	Setting range	Unit	Default
CH1 In Bias	40313	CH 1 input correction	-999 to 999	Digit	000
CH1 Tag Name	40314	CH 1 channel name□□□□	Front two characters, E.g.) C H - 1	—	CH
	40315		Rear two characters, E.g.) C H - 1	—	-1
CH2 Record ^{※3}	40319	CH 2 using/recording	0: USE, 1: NO USE	—	On
CH2 In Type ^{※3}	40320	CH 2 input type	Same as addr. 40301 setting	—	TC.K1
CH2 Temp Unit ^{※3}	40321	CH 2 temp. unit	0: °C, 1: °F	—	°C
CH2 Lo Graph ^{※3}	40322	CH 2 graph low-limit scale value	※Refer to the 8.2.1 (4), (5)	Digit	-200
CH2 Hi Graph ^{※3}	40323	CH 2 graph high-limit scale value			1350
CH2 Lo Range ^{※3}	40324	CH 2 low-limit input value	※Refer to the 8.2.1 (6), (7)	—	—
CH2 Hi Range ^{※3}	40325	CH 2 high-limit input value		—	—
—	40326	—	—	—	—
CH2 Lo Scale ^{※3}	40327	CH2 low-limit scale display value	-1999 to 9999	Digit	000.0
CH2 Hi Scale ^{※3}	40328	CH 2 high-limit scale display value			100.0
CH1 Hi Scale Decimal Point ^{※2}	40329	CH 1 scale dot position	0:0, 1:0.0, 2:0.00, 3:0.000	—	0.0
CH2 DP Unit ^{※3}	40330	CH 2 record display unit	Same as addr. 40311	—	%
CH2 In Bias ^{※3}	40331	CH 2 input correction	-999 to 999	Digit	000
CH2 Tag Name ^{※3}	40332 to 40333	CH 2 channel name	Same as addr. 40313 to 40314	—	CH-2

※1: Displays only when input type(In Type) is temperature sensor.

※2: Displays only when input type(In Type) is analog (voltage/current).

※3: Displays only for 2 channels model.

(4) Record mode setup group [Record Setup]

Parameter	Addr	Description	Setting range	Unit	Default
Rec Mode	40080	Record mode	0: Graph 1: Digital	—	Graph
Rec Speed ^{※1}	40081	Record speed	0: 10, 1: 30, 2: 60, 3: 120, 4: 240 5: 480, 6: 960	mm/hour	10mm
Memo Period ^{※1}	40082	Digital memo period	※Refer to the 8.2.3 (6)	min	30min
Rec Period ^{※2}	40083	Record cycle	※Refer to the 8.2.3 (9)	m.s	01m00s
Rec Font	40084	Record font	0: Korea, 1: English	—	Korea
Alarm Speed	40085	Record speed for alarm	0: 10, 1: 30, 2: 60, 3: 120, 4: 240, 5: 480, 6: 960	mm/hour	10mm

※1. Displays only when record mode (Rec Mode) is set as 'Graph'.

※2. Displays only when record mode (Rec Mode) is set as 'Digital'.

(5) Option setup group [Option Setup]

Parameter	Addr	Description	Setting range	Unit	Default
Digital Input 1	11	DI-1 input terminal function	0: Stop, 1: Run	—	Off
Digital Input 2	12	DI-2 input terminal function	0: Off, 1: Memo	—	Off
PWR On State	2	Record run/stop when power is supplied	0: Run, 1: Stop	—	Run
Run On State	3	Setting list printing during recording	0: Off, 1: List	—	List

**(6) RS485 communication setup group [RS485 Setup]
(Read Only)**

Parameter	Addr	Description	Setting range	Unit	Default
Address	40001	Communication address	01 to 99	—	01
Baud Rate	40002	Communication speed	0: 1200, 1: 2400, 2: 4800, 3: 9600, 4: 19200, 5: 38400, 6: 57600	bps	9600bps
Parity bit	40003	Parity bit	0: None, 1: Odd, 2: Even	—	None
Stop Bit	40004	Stop bit	0: 1, 1: 2	Bit	2
Response Time	40005	Response time	50 to 990	msec	50
Com Write	40006	Communication write enable/disable	0: Enable, 1: Disable	—	Enable

(7) Date/Time setup group [Date/Time Setup]

Parameter	Addr	Description	Setting range/Unit	Default
Date	40052	Year	00 to 99	
	40053	Month	00 to 12	
	40054	Day	00 to 31	
Time	40055	Hour	00 to 23	
	40056	Minute	00 to 59	
	40057	Second	00 to 59	

(8) Environment setup group [Environment Setup]

Parameter	Addr	Description	Setting range	Unit	Default
Display Mode	101	CH 1 display mode	0: Off, 1: On	—	2CH
	102	CH 2 display mode	0: Off, 1: On	—	—
	103	Display standard mode ^{*1}	0: Displays 2 channels, 1: Display per 1 channel in turn automatically	—	—
Setting Lock	40066	Lock	0: Off, 1: Loc1, 2: Loc2, 3: Loc3	—	Off
Backlight	40067	Backlight	0: Temp, 1: Always	—	Temp

(9) Others

Address	Description		Setting range			Default
1	Record run/stop (Recording RUN/STOP)		0: STOP, 1: RUN			0
4	SV initialization (Parameter initialization) *1		0: OFF, 1: ON			0
5	Memo (Memo)		0: OFF, 1: ON			0
41	Feed (Paper Feed)		0: STOP, 1: FEED			0
52	List printing (Paper List Print)		0: STOP, 1: PRINT			0
10001	Printing paper status(Paper Status)		0: Paper, 1: Paper End			0
10101	CH1 AL1 Status		0: CH1-AL1 off, 1: CH1-AL1 on			0
10102	CH1 AL2 Status		0: CH1-AL2 off, 1: CH1-AL2 on			0
10103	CH2 AL1 Status		0: CH2-AL1 off, 1: CH2-AL1 on			0
10104	CH2 AL2 Status		0: CH2-AL2 off, 1: CH2-AL2 on			0
10301	Digital input 1 status(DI1-Status)		0: OFF, 1: ON, operates only for ON			0
10302	Digital input 2 status (DI2-Status)		0: OFF, 1: ON, operates only for ON			0
30001	CH1-display value(PV)		—			—
30002	CH1	BIT position	Unit	Unit group	Status	Display value dot position
	Unit	15 to 10	※2	※2	00: NONE	00: 0
	Unit group	9 to 4			01: HHHH	01: 0.0
	Status	3 to 2			10: LLLL	10: 0.00
	Display value dot	1 to 0			11: BURN	11: 0.000
30003	CH2-display value(PV)		—			—
30004	CH1	BIT position	Unit	Unit group	Status	Display value dot position
	Unit	15 to 10	※2	※2	00: NONE	00: 0
	Unit group	9 to 4			01: HHHH	01: 0.0
	Status	3 to 2			10: LLLL	10: 0.00
	Display value dot	1 to 0			11: BURN	11: 0.000
30101	Serial No H					
30102	Serial No L					
30103	Software Version					
30104	Hardware Version					
30105	Model Name 1		"KR"			
30106	Model Name 2		"N5"			
30107	Model Name 3		"0- "			
30108	Model Name 4		"X0 " X: marked by the model			

Address	Description	Setting range	Default
30109	Model Name 5	"0X " X: marked by the model	
30110	Model Name 6	" -X " X: marked by the model	
30111	Model Name 7	"0 "	
30112	Model Name 8	" "	
30113	Model Name 9	" "	
30114	Model Name 10	" "	
30118	Coil Start Address	1	
30119	Coil Quantity	12	
30120	Input Start Address	10001	
30121	Input Quantity	15	
30122	Holding REG Start Address	30001	
30123	Holding REG Quantity	26	
30124	Input REG Start Address	40001	
30125	Input REG Quantity	154	
42001 to 16	User unit font 0 ^{※3}	User 0 (16×16 size)	
42017 to 32	User unit font 1 ^{※3}	User 1 (16×16 size)	
42033 to 48	User unit font 2 ^{※3}	User 2 (16×16 size)	
42049 to 64	User unit font 3 ^{※3}	User 3 (16×16 size)	
42065 to 80	User unit font 4 ^{※3}	User 4 (16×16 size)	
42081 to 96	User unit font 5 ^{※3}	User 5 (16×16 size)	
42097 to 112	User unit font 6 ^{※3}	User 6 (16×16 size)	
420113 to 128	User unit font 7 ^{※3}	User 7 (16×16 size)	
420129 to 144	User unit font 8 ^{※3}	User 8 (16×16 size)	
420145 to 160	User unit font 9 ^{※3}	User 9 (16×16 size)	
50001 to 52048	User Logo ^{※3}	384×80 size	

- ※1. When initializing SV, SVs related communication are also initialized.
- ※2. Unit and Unit group values are used at user unit download function of the comprehensive device management program (DAQMaster).
- ※3. Download user images such as unit, and logo, etc. (Refer to 10.3 Dedicated function for KRN50 (2) Downloading User Images.)

10. Comprehensive device management program (DAQMaster)

10.1 Overview

DAQMaster is a comprehensive device management program that can be used with Autonics thermometers, panel meters, pulse meters, counters, recorders, and indicators, etc.

DAQMaster provides GUI control for easy and convenient management of parameters and multiple device data monitoring.

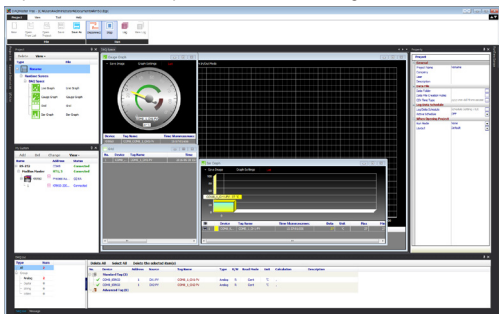

Note

You can download DAQMaster and the user manual of DAQMaster at Autonics homepage (www.autonics.com).

This user manual describes only KRN50 functions of DAQMaster. For more information about DAQMaster program, refer to the user manual of DAQMaster.

10.2 Features

DAQMaster has the following features:

- **Multiple Device Support**
Simultaneously monitor multiple devices and set parameters.
Simultaneously connect units with different addresses in a single device.
Multiple RS-233 ports are available for communications using Modbus remote terminal unit.
- **Device Scan**
In cases of multiple units (with different addresses) connected together, the unit scan function automatically searches for units.
- **Convenient User Interface**
Freely arrange windows for data monitoring, properties, and projects.
Saving a project also saves the screen layout.
- **Project Management**
You can save added device information, data monitoring screen layouts, and I/O source selection as project files. Opens project files to load the saved settings.
Provides a project list for simple and easy project file management.
- **Monitoring Data Log**
When monitoring, data log files can be saved as either DAQMaster data files (.ddf) or CSV (.csv) files. Open files saved in .csv format directly from Microsoft Excel.
Define log data file naming/saving rules and destination folders to make file management convenient.
- **Data Analysis**
Performs grid and graph analyses of .ddf data files using DAQMaster's data analysis feature. Saves grid data as .rtf, .txt, .html, or .csv files in Data Grid.
- **Print Modbus Map Table Report**
Print address map reports of registered Modbus devices. Modbus map table reports can be saved as .html and .pdf formats.
- **Multilingual Support**
Supports Korean, English, Japanese, Simplified Chinese. To add a different language, modify the files in the Lang folder, rename, and save.
- **Script Support**
Uses the Lua Script language and deals with different I/O processes for individual devices.

10.3 Dedicated function for KRN50

The following are special features for KRN50 while in communication with DAQMaster.

(1) Accessing Record Backup Data

To get the recorded data, click '...' button located on the right of Record Backup in the Property window.

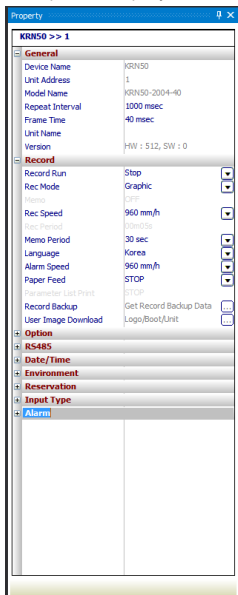

To read memory information, the device status must be Connected and not Run.

There are also cases in which you cannot read from memory depending on KRN50 parameter setting.

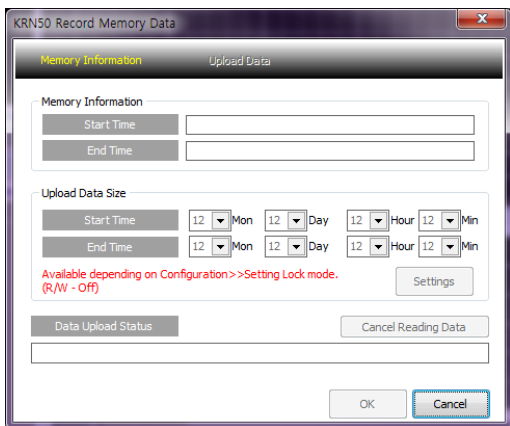

Once all conditions are met and ready to get memory data, follow the steps below:

- i. Run [Memory Information] in KRN50 Record Memory Data window. It gets the information from currently saved memory.
- ii. Set [Uploaded Data Size].
- iii. Run [Upload Data].
- iv. You can cancel the operation while data is being uploaded. When data reading is complete, OK button is enabled.
- v. If you click OK, recorded data will be shown in two screens - the Grid and the Graph.

(2) Downloading User Images

User Image allows you to download images to KRN50 and change logo, unit and boot images.

You can also reset images back to the original status. This is also a self protocol, so cannot download images during Run.

1) Download logo

You can change the company logo image on contents that are printed on recording paper.

Logo image should be 384×80 pixel of bitmap file.

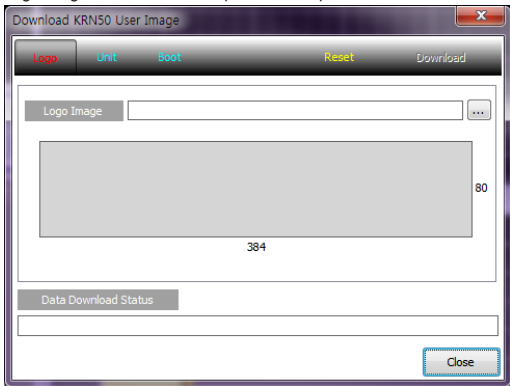

2) Download Units

There are 0 to 9 user units.

The download procedure is: select a unit list → select a destination to save → double-click a unit image to add the image → download.

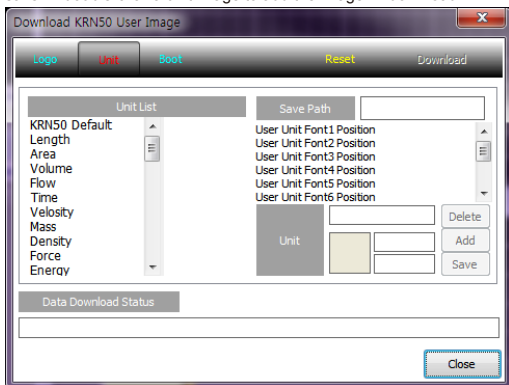

3) Download boot images

The boot image (logo image) appears on LCD upon initial power supply to KRN50.

You can change booting logo image which displays when KRN50 is power ON.

The image should be 128×32 pixel of bitmap file.

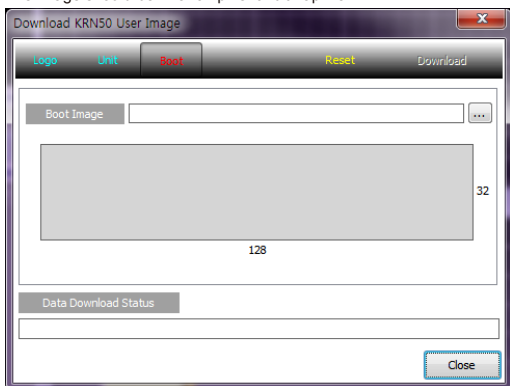

Distributor

Autonics

Sensors & Controllers

www.autonics.com

■ Corporate Headquarters

18 Bansong-ro, 513 Beon-gil, Haeundae-gu, Busan, South Korea 48002

■ Overseas Business Headquarters

#402-303, Bucheon Techno Park, 655, Pyeongcheon-ro, Wonmi-gu, Bucheon, Gyeonggi-do, South Korea 14502

Tel: 82-32-610-2730 / Fax: 82-32-329-0728 / E-mail: sales@autonics.com

■ Brazil – Autonics do Brasil Comercial Importadora Exportadora Ltda

Tel: 55-11-2307-8480 / Fax: 55-11-2309-7784 / E-mail: comercial@autonics.com.br

■ China – Autonics electronic(Jiaxing) Corporation

Tel: 86-21-5422-5969 / Fax: 86-21-5422-5961 / E-mail: china@autonics.com

■ India – Autonics Automation India Private Limited

Tel: 91-22-2781-4305 / Fax: 91-22-2781-4518 / E-mail: india@autonics.com

■ Indonesia – PT. Autonics Indonesia

Tel: 62-21-8088-8814/5 / Fax: 62-21-8088-4442(4440) / E-mail: indonesia@autonics.com

■ Japan – Autonics Japan Corporation

Tel: 81-3-3950-3111 / Fax: 81-3-3950-3191 / E-mail: ja@autonics.com

■ Malaysia – Mal-Autonics Sensor Sdn. Bhd.

Tel: 60-3-7805-7190 / Fax: 60-3-7805-7193 / E-mail: malaysia@autonics.com

■ Mexico – Autonics Mexico S.A. DE C.V.

Tel: 52-55-5207-0019 / Fax: 52-55-1663-0712 / E-mail: ventas@autonics.com

■ Russia – Autonics Corp. Russia Representative Office

Tel/Fax: 7-495-660-10-88 / E-mail: russia@autonics.com

■ Turkey – Autonics Otomasyon Ticaret Ltd. Sti.

Tel: 90-216-365-9117/3/4 / Fax: 90-216-365-9112 / E-mail: infotr@autonics.com

■ USA – Autonics USA, Inc.

Tel: 1-847-680-8160 / Fax: 1-847-680-8155 / E-mail: sales@autonicsusa.net

■ Vietnam – Cong Ty TNHH Autonics Vina

Tel: 84-8-3771-2662 / Fax: 84-8-3771-2663 / E-mail: vietnam@autonics.com

Major Products

· Photoelectric Sensors · Fiber Optic Sensors · Door Sensors · Door Side Sensors · Area Sensors · Proximity Sensors · Pressure Sensors
· Connectors/Socket · Rotary Encoders · Panel Meters · Counters · Timers · Temperature Controllers · SSRs/Power Controllers
· Sensor Controllers · Graphic/Logic Panels · Temperature/Humidity Transducers · Switching Mode Power Supplies
· Stepper Motors/Drivers/Motion Controllers · I/O Terminal Blocks & Cables · Display Units · Control Switches/Lamps/Buzzers
· Field Network Devices · Tachometer/Pulse (Rate) Meters · Laser Marking System (Fiber, CO₂, Nd:YAG) · Laser Welding/Cutting System
· Recorders · Indicators · Converters · Controllers · Thyristor power controllers · Temperature Sensors · Pressure Transmitters
· Temperature Transmitters · Thermometers · Pressure Gauges

■ Any proposal for product improvement and development : product@autonics.com

Dimensions or specifications on this manual are subject to change and some models may be discontinued without notice.

AEP-E-0104C_20161220