

CO₂ Laser Marker
LP-300 SERIES
Operation Manual



Preface

Thank you for purchasing Laser Marker .

For full use of this laser marker safely and properly, please read this manual carefully.











This system has been strictly checked and tested prior to its delivery, however, please make sure that this system operates properly before using it.

In case that the system becomes damaged or does not operate as specified in this manual, contact the shop you bought it or our sales office.

■ Symbol Indications

This manual uses a variety of symbols to explain safety precautions, instructions, and references for operating personnel.

Before reading this manual, fully understand the contents of these indications.

 DANGER	“DANGER” denotes hazards that could result in serious personnel injury or death when handling error occurs, and emergency precautions (urgency level) when any dangerous situation causes.
 WARNING	“WARNING” denotes hazards that could result in serious personnel injury or death when handling error occurs.
 CAUTION	“CAUTION” denotes that any damages on personnels or objects could result in when handling error occurs.
	This symbol denotes the possibility of fire.
	This symbol denotes a general prohibition notice.
	This symbol denotes the prohibition of disassembling the product.
	This symbol denotes the prohibition of touching the specified place.
	This symbol denotes a general action which operators must take.
 CHECK	“CHECK” denotes any instructions or precautions for using this product.
 REFERENCE	“REFERENCE” denotes any hints for operation, detail explanations, or references.

■ Note

1. Contents of this manual will be changed without notice.
2. This manual and software must not be partially or totally copied or revised.
3. If there are any questions, mistakes, or comments in this manual, please notify us.
4. Please remind that we do not have responsibility of any results of operations in regardless of the above 3 clauses.

■ Order Placement Recommendations and Considerations

The Products and Specifications listed in this document are subject to change (including specifications, manufacturing facility and discontinuing the Products) as occasioned by the improvements of Products. Consequently, when you place orders for these Products, Panasonic Industrial Devices SUNX asks you to contact one of our customer service representatives and check that the details listed in the document are commensurate with the most up-to-date information.

SAFETY PRECAUTIONS

Panasonic Industrial Devices SUNX is consistently striving to improve quality and reliability. However, the fact remains that electrical components and devices generally cause failures at a given statistical probability. Furthermore, their durability varies with use environments or use conditions. In this respect, check for actual electrical components and devices under actual conditions before use. Continued usage in a state of degraded condition may cause the deteriorated insulation. Thus, it may result in abnormal heat, smoke or fire. Carry out safety design and periodic maintenance including redundancy design, design for fire spread prevention, and design for malfunction prevention so that no accidents resulting in injury or death, fire accidents, or social damage will be caused as a result of failure of the Products or ending life of the Products.

The Products are designed and manufactured for the industrial indoor environment use. Make sure standards, laws and regulations in case the Products are incorporated to machinery, system, apparatus, and so forth. With regard to the mentioned above, confirm the conformity of the Products by yourself.

Do not use the Products for the application which breakdown or malfunction of Products may cause damage to the body or property.

- i) usage intended to protect the body and ensure security of life
- ii) application which the performance degradation or quality problems, such as breakdown, of the Products may directly result in damage to the body or property

It is not allowed the use of Products by incorporating into machinery and systems indicated below because the conformity, performance, and quality of Products are not guaranteed under such usage.

- i) transport machinery (cars, trains, boats and ships, etc.)
- ii) control equipment for transportation
- iii) disaster-prevention equipment / security equipment
- iv) control equipment for electric power generation
- v) nuclear control system
- vi) aircraft equipment, aerospace equipment, and submarine repeater
- vii) burning appliances
- viii) military devices
- ix) medical devices (except for general controls)
- x) machinery and systems which especially require the high level of reliability and safety

ACCEPTANCE INSPECTION

In connection with the Products you have purchased from us or with the Products delivered to your premises, please perform an acceptance inspection with all due speed and, in connection with the handling of our Products both before and during the acceptance inspection, please give full consideration to the control and preservation of our Products.

WARRANTY PERIOD

Unless otherwise stipulated by both parties, the warranty period of our Products is one year after the purchase by you or after their delivery to the location specified by you.

The consumable items such as battery, relay, filter and other supplemental materials are excluded from the warranty.

SCOPE OF WARRANTY

In the event that Panasonic Industrial Devices SUNX confirms any failures or defects of the Products by reasons solely attributable to Panasonic Industrial Devices SUNX during the warranty period, Panasonic Industrial Devices SUNX shall supply the replacements of the Products, parts or replace and/or repair the defective portion by free of charge at the location where the Products were purchased or delivered to your premises as soon as possible.

However, the following failures and defects are not covered by warranty and we are not responsible for such failures and defects.

- (1) When the failure or defect was caused by a specification, standard, handling method, etc. which was specified by you.
- (2) When the failure or defect was caused after purchase or delivery to your premises by an alteration in construction, performance, specification, etc. which did not involve us.

-
- (3) When the failure or defect was caused by a phenomenon that could not be predicted by the technology at purchasing or contracted time.
 - (4) When the use of our Products deviated from the scope of the conditions and environment set forth in the instruction manual and specifications.
 - (5) When, after our Products were incorporated into your products or equipment for use, damage resulted which could have been avoided if your products or equipment had been equipped with the functions, construction, etc. the provision of which is accepted practice in the industry.
 - (6) When the failure or defect was caused by a natural disaster or other force majeure.
 - (7) When the equipment is damaged due to corrosion caused by corrosive gases etc. in the surroundings.

The above terms and conditions shall not cover any induced damages by the failure or defects of the Products, and not cover your production items which are produced or fabricated by using the Products. In any case, our responsibility for compensation is limited to the amount paid for the Products.

SCOPE OF SERVICE

The cost of delivered Products does not include the cost of dispatching an engineer, etc. In case any such service is needed, contact our sales representative.

■ Trademarks

- Window is a registered trademark or trademark of U.S.A. Microsoft Corporation in U.S.A and other countries.
All other product names and companies provided in this manual are trademarks or registered trademarks of their respective companies.

■ Warranty of Product

1. Warranty Period

- The warranty period is one year after delivery of the system to the ordered place by a purchaser.

2. Warranty Limitation

- When a failure is produced by a supplier, exchange of the failure parts of the system, or repair of it is performed in the responsibility of the supplier.

However, if failure of the system has resulted from the following reasons, the warranty is void.

- 1) Any fault or defect caused by inadequate handling or abnormal use.
- 2) Any fault or defect caused by the other reasons than the supplier's fault.
- 3) Any fault or defect caused by modification or repair of the system by any others than the suppliers.
- 4) Any fault or defect caused by force majeure.

Note that the warranties set forth herein cover faults or defects of delivered products alone and do not cover any damage induced by faults or defects of delivered products.

■ Network Security

As you will use this product connected to a network, your attention is called to the following security risks.

- (1) Leakage or theft of information through this product
- (2) Use of this product for illegal operations by persons with malicious intent
- (3) Interference with or stoppage of this unit by persons with malicious intent

It is your responsibility to take precautions such as those described below to protect yourself against the above network security risks.

- Use this product in a secure network by using protection tools such as a firewall.
- If this product is connected to a network that includes PCs, make sure that the system is not infected by computer viruses or other malicious entities (using a regularly updated antivirus program, anti-spyware program, etc.).
- Use this product in an environment that has LAN, VPN (Virtual Private Network) or leased line network.
- Use this product in an environment where only limited people concerned can enter.
- Use this product and connected devices such as a PC and tablet securing safety.
- Do not install this product in locations where the product or the cables can be destroyed or damaged by persons with malicious intent.

Note that incorrect setting of the connection to the existing LAN might cause malfunction in the devices on the network.

Consult your network administrator before connecting.

MEMO

Cautions in Handling Laser Beam

This product falls into Class 4 laser (marking laser) and Class 2 laser (guide laser) based on the classifications of IEC60825-1 "Safety of laser products".

Class 4 laser refers to "Laser products for which intrabeam viewing and skin exposure is hazardous and for which the viewing of diffuse reflections may be hazardous. These lasers also often represent a fire hazard."

Perform the safety protection measure before using the system. Refer to "Safety Protection Measures" (P.8) for details.

Item	Specification	Remarks
Wave Length	10.6 μ m	Invisible beam
Laser Medium	CO ₂	—
Max. Output *1	30W	—
Laser frequency	10kHz	—
Class	4	—
NOHD *2	3.3m	Normal ocular hazard distance
MPE*3	1000W/m ²	Maximum permissible exposure
NHZ	NHZ represents the area where the amount of beam irradiance or radiant exposure exceeds the maximum permissible exposure to eyes. It is equal to the value of NOHD at a maximum. NHZ varies depending on the reflectance or surface condition of works. Please calculate it based on the actual working environment.	Nominal hazard zone

*1: The maximum output is the maximum value that the laser oscillator outputs laser beam.

This product is set to 10W as the average output of laser oscillator. Moreover, the optical power emitted from the laser marker is decreased further.

*2: NOHD represents the distance from the light source of laser beam, where the amount of beam irradiance or radiant exposure is equal to the maximum permissible exposure to eyes.

*3: MPE means the assumed exposure duration for determination of the value. The value calculated on 10 seconds.

■ Laser Radiation Range

Unit: mm

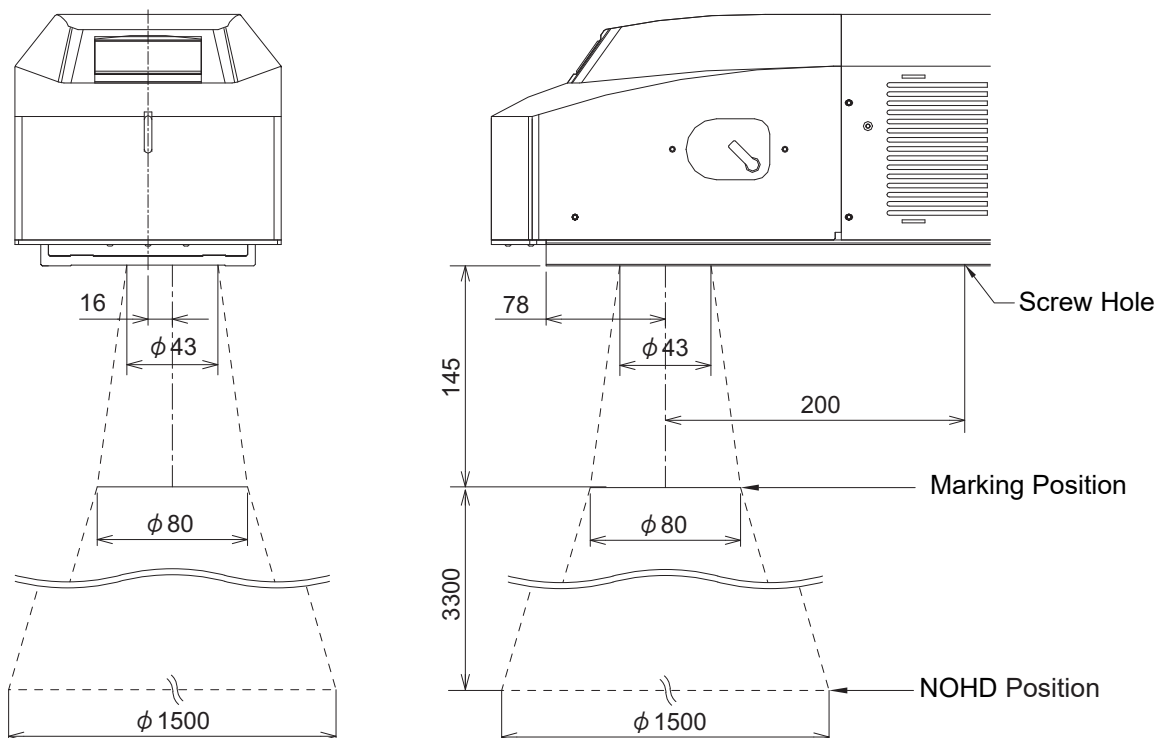



DANGER

Never look at laser beam directly or through lens.

Diffused reflected beam is also harmful. CO₂ laser does not enter into eye's retina, however, if it exposed to the eyes, it can inflict severe corneal injuries.

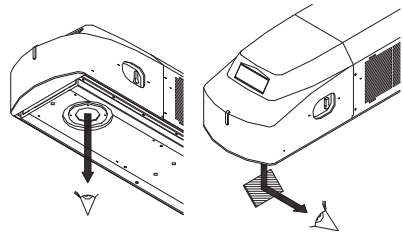

Never touch laser beam. Be careful not to touch laser beam with clothing as well. Burning into deep skin might result.

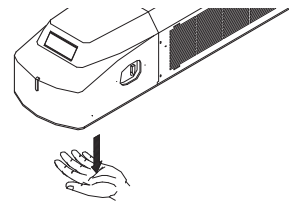

WARNING

Wear laser protective goggles for operator's eyes. The goggles should be used against scattered beam, so avoid to direct beam or reflection beam.

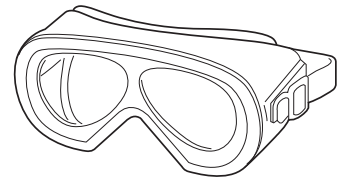

In order to prevent unexpected exposures from object to be marked or its peripherals, set protective enclosure which is made of acrylic resin, glass, or metal to enclose the laser radiation area.

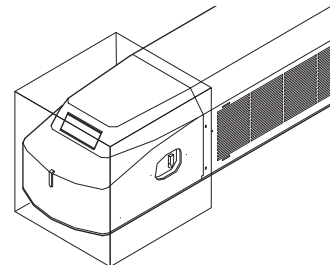

Never disassemble the product.

Exposure of laser beam or electric shock by high-voltage area might occur.

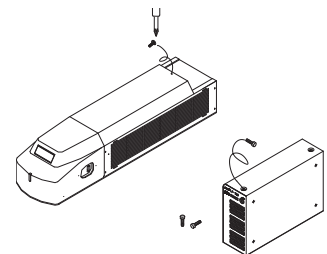

Read this manual thoroughly, and do not operate any other methods except the instructions provided in this manual.

Exposure of laser beam might occur.



Safety Protection Measures

This product falls into Class 4 laser (marking laser) and Class 2 laser (guide laser) based on the classifications of the Safety of laser products IEC60825-1.

Perform the safety protection measure shown below before using the system.

For more detail instruction, refer to each of the standard.

1. Construction of interlock system

In order to prevent exposure to laser beam accidentally reflected from the laser marking object or from its circumferential areas, place a protective enclosure so that it can enclose the area in the range of laser radiation, and construct the interlock mechanism in the system.

Additionally, install the control part that is not to exposure to the laser beam. Refer to "Construction Sample of Interlock System" (P.14).



- For laser pumping is shut-off by interlock system, construct a laser re-pumping system by manual operation for safety.

2. Wearing protective goggles

For protection eyes of an operator, make it mandatory to wear goggles against laser beam in the laser controlled area.

For this product, use the laser protective goggles or glasses which meet the following requirements.

- The goggles or glasses that have Optical Density (OD) of more than 6 at wavelength 10600nm (10.6 μ m).
- Through the goggles or glasses, the laser radiation indicator should be recognized.
- ANSI Z136 and CE certified laser safety goggles or glasses

The protective goggles can momentarily protect the eyes against the scattered beam. Never look at the direct beam or reflected beam even when the goggles are used.

3. Protective enclosure

In order to prevent exposure to laser beam accidentally reflected from the laser marking object or from its circumferential areas, place a protective enclosure so that it can enclose the area in the range of laser radiation.

Construct the enclosure with proper reflectance, durability and thermal resistance materials that does not transmit a wavelength of 10600 nm (10.6 μ m).

Recommended materials for the enclosure: metals such as iron, aluminum, stainless steel, or acrylic resins.

For acrylic plate, its thickness should be more than 3 mm and it is recommended to use the plate that has a color to reduce the secondary radiation beam such as spark during the lasing.

Design the enclosure not to leak the laser beam from the joint parts.

Example of the joint parts:

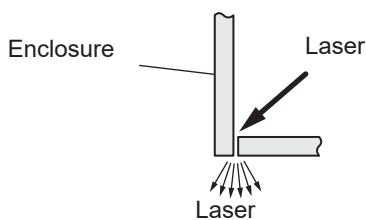

Danger of laser exposures

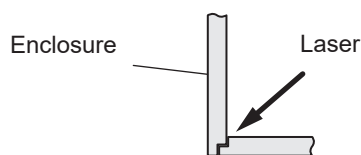

Example of recommended joint design

4. Key control

In order to avoid the operation of the system by the person without authorization and allowance, the laser safety manager must remove key and keep it when not in use.



- It is obligated by IEC/FDA/JIS that laser products shall incorporate a key-actuated master control. Actuation of Our laser marker is basically controlled by the key switch located on the front of the power supply box. However, in considering situations when the laser marker is operating as a part of a larger system, the laser marker turns on if the key switch is already in ON position, and power is supplied.
- In this case, be sure that the external system controls the operation of the laser marker with a key-actuated master control.

5. Power failure recovery

For power failure occurs on the laser marker, construct a laser re-pumping system by manual operation for safety.

6. Radiation direction of laser beam

To assure safety, be sure to place the protective enclosure. Measures should be taken so that the direction of laser radiation can be seen and checked by others as well as an operator. (The warning labels are adhered to this product with shipment. Do not peel them off.)

7. Termination of laser beam

Terminate a laser beam path within the laser radiation range by using a flame-resistant object. Do not use the specular object for the termination.

8. Path of laser beam

The laser beam path should be set avoiding the eye level of workers at both sitting and standing time.

9. Illumination

Make the area surrounding the laser marker well-lighted as much as possible. Because the pupils are contracted in the well-lit place, it reduces the risk to the eyes.

10. Protective clothing

Exposure of the skin to the laser beam may cause a skin burn. Exposure of the clothing to the laser beam may cause burning as well. Wear the clothing which can minimize the exposure of the skin to the laser and which is flame-resistant.

11. Appointment of laser safety manager

By appointing a laser safety manager, ensure that the laser product is handled safely.

Items that the laser safety manager has to manage and execute are as follows:

1. Implementation of countermeasure against the prevention of disability from laser beam
2. Setting and management of laser management area
3. Management of laser device and system and key
4. Inspection and maintenance of laser device, and storage of records
5. Inspection, maintenance, and check the status of use of protective equipment
6. Execution of safety education and training for users for the laser



REFERENCE

- There is a case where related regulations are set for using the laser product depending on a country and a region. When use the laser marker, follow these regulations.

Functions for Safety Measures

This laser marker has the functions shown below for safety measures.

■ Head Section

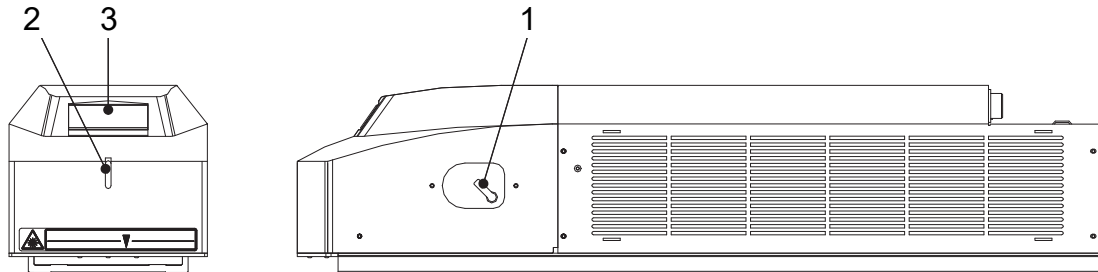

1. Shutter Lever

- The laser can be radiated with the shutter opened, or it cannot be radiated with the shutter closed. However, the guide laser is available.

2. Laser Radiation Indicator

- The indicator lights in red for 0.5 seconds just after the power supply is turned ON. Then, it lights in blue during trigger standby.
The color of the indicator is changed into red during marking.



REFERENCE

- During excitation of the laser (approx. 15 seconds), the product is not ready for radiating laser.

3. File No./Error Code Display: FILE No./ERROR CODE

- The selected file No. is displayed. When an error occurs, the corresponding error code is displayed as well. Refer to “5 Troubleshooting” (P.186) for details of error code.

■ Labels

A variety of labels shown below are affixed to the head part of the laser marker.

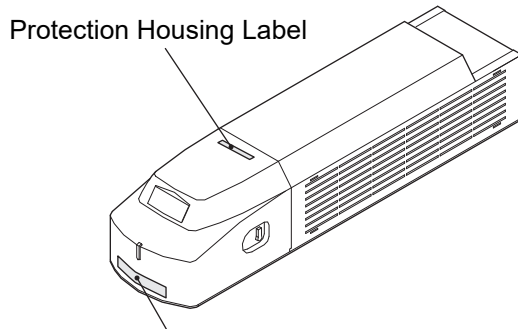

Warning, explanatory, aperture label

Head rear side

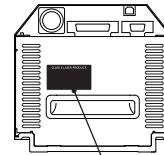

Certification and identification label *1

• LP-310

Warning, explanatory, aperture label

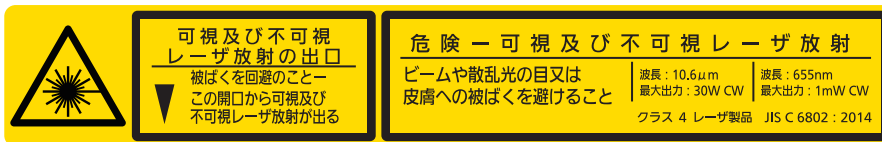

Protection Housing Label

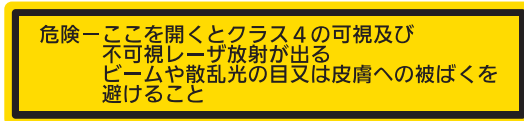

• LP-310-A

• LP-310-C

Warning, explanatory, aperture label



Protection Housing Label



Certification and identification label *1



*1: Attached to LP-310-A only.

■ Power Supply BOX

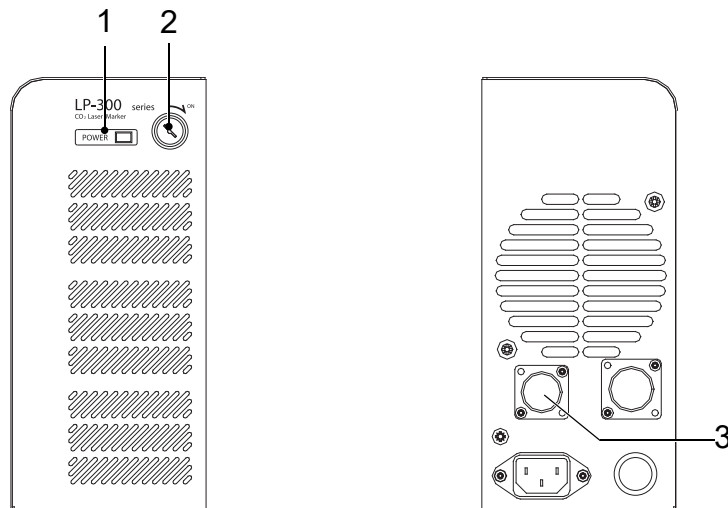

1. Power Supply Display

- When turning ON the key switch, this indicator flashes in green.
When the system starts up and runs completely, the indicator switches into lighting status.

2. Key Switch

- This key switch is used to start the laser marker system. While the switch is ON, the key cannot be removed, however, while it is OFF, the key can be removed. Remove the key while not using the laser marker, and maintain and control the key by the safety controller without fail.
- Since the ON/OFF operation of the key switch makes a load to the laser marker, do not turn OFF the power until completing the start of the system. Besides, leave an interval for at least 5 seconds from turning OFF the power to turning ON the power again.

3. Interlock Connector

- This interlock connector controls the deactivating/activating status of the laser. It enables to construct the interlock system.

■ Interlock Connector

- This product is equipped with the interlock connector to the power supply box. Use this interlock connector.

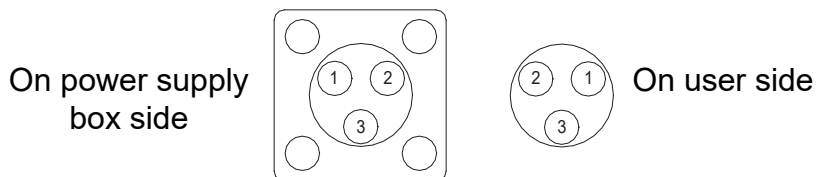

Interlock Connector: SRCN6A13-3P Japan Aviation Electronics Industry,Ltd.

Connector on the body side: SRCN2A13-3S Japan Aviation Electronics Industry,Ltd.

No.	Signal Name	Name	Content
1	INTERLOCK COM.	Interlock Common	Common for interlock
2	N.C.	-	Do not connect anything.
3	INTERLOCK	Interlock Input	When connected to INTERLOCK COM., the product is ready for laser radiation. When the product is in open status, the laser radiation is stopped.

* Keep the OPEN state between INTERLOCK (Pin 3) and INTERLOCK COM. (Pin 1) for 1 sec. or more when they are opened. If the OPEN state is too short, the laser tube error (E23) may occurs.

■ I/O Connector

- This product is equipped with the laser radiation stop input in the I/O connector.

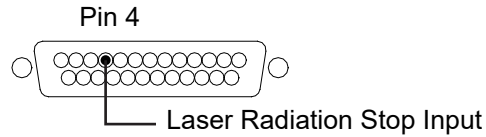

Laser Marker Side Connector Type : Female D-sub 25 pin
 User Side Connector Type : Male D-sub 25 pin *

- * As a user side connector, following items are attached to this product.
 [Attached item] User Side Connector : HDBB-25P (Hirose Electric Co., Ltd.)
 [Attached item] User Side Connector Cover : HDB-CTF (Hirose Electric Co., Ltd.)

Laser Radiation Stop Input

- When changing the status of both laser radiation stop input (Pin 4) and output common (Pin 15) into open status, the laser radiation is stopped and the marking is invalid.
 When performing marking, connect both laser radiation stop input (Pin 4) and output common (Pin 15).



• This product is not activated by connecting **IN COM.** (Pin 14), **OUT COM.** (Pin 15), and **LASER STOP** (Pin 4) terminals of the I/O connector.

■ Connecting Sample (In case of operating only laser marker)

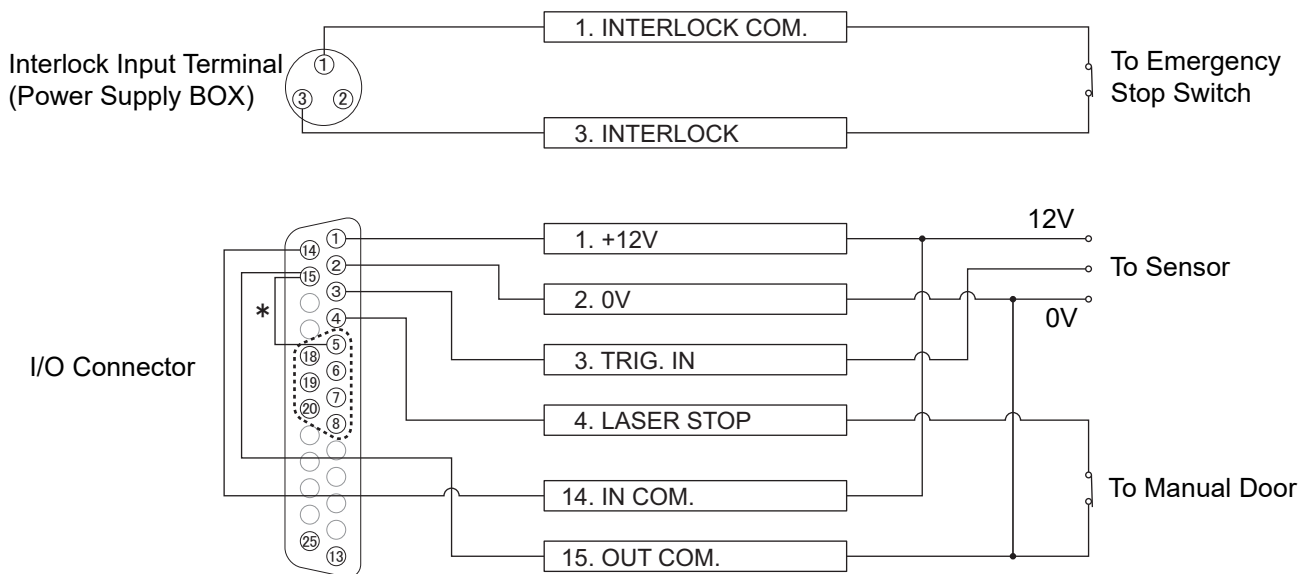

- * Example when only the file No. 1 is used. To change the files, connect the pin No. 5 to 8 and 18 to 20 (D0 to D6) to the external control device.

■ Construction Sample of Interlock System

- For operating this product, construct the protective enclosure enclosing the range of the laser radiation for protecting the exposure caused by the reflection of the laser radiation from the object being marked or the surrounding objects, and also construct the interlock system at the same time. The following figure shows the construction sample of the interlock system.

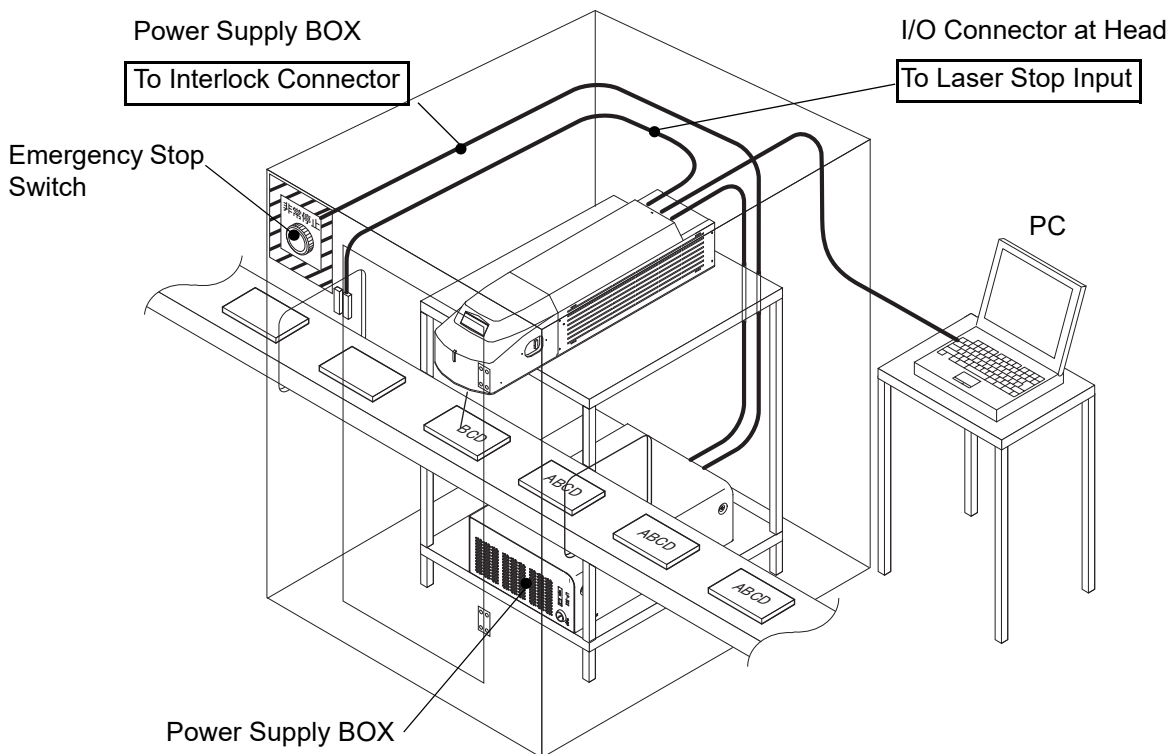

■ Operation at Interlock Input

As shown in the table below, this product outputs error state by canceling the interlock input and also stops the laser oscillation aiming for safety use of this product.

Status of Interlock Input	Shutter	Laser Oscillation (Marking Operation)	Laser Radiation Indicator	Laser Marker	
				Status	Head display panel
Short-circuit	OPEN	ON	Red	Normal Operation	File No.
		OFF	Blue		
Release	CLOSE	OFF	Blue	Alarm Status	Error Code
	OPEN	OFF	Blue		
Release ↓ Short-circuit	OPEN	OFF	Blue	Ready OFF	Error Code ↓ after 15 sec. File No.
	CLOSE			Ready ON	
Short-circuit ↓ Release (Releasing during marking operation)	OPEN	ON ↓ OFF	Red ↓ Blue	Normal ↓ Alarm Status	File No. ↓ Error Code

· When primary AC power supply of the system is performed as a safety measure, process AC power cable to set the switch as follows.

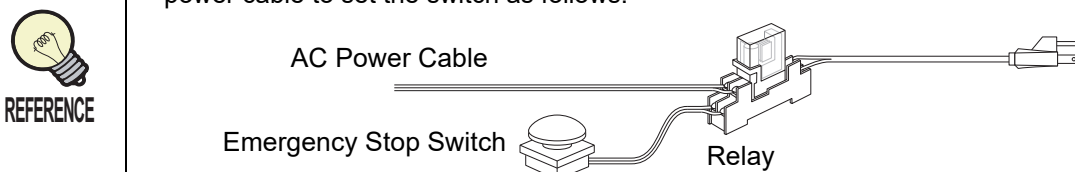

Cautions in Handling

■ Handling the System



WARNING

This product has been developed/produced for industrial use only.

When using the system, do not touch laser beam with any part of body, papers, or clothing, etc.

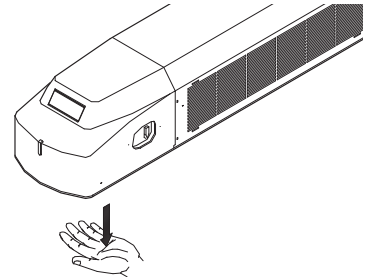

This product contains ZnSe (zinc selenide) in the lens mounted on the laser radiation window. If the lens is damaged, care should be taken of the following.

- In order to prevent from swallowing of flakes or particles, inhaling them, or adhering them to skin, be sure to wear glove, mask and protective goggles.
- When disposing the lens, be sure to obey the disposing method prescribed in the regulations of user's region/countryfully. Do not dispose the lens with general industrial waste.
- Do not throw the lens into the fire.
- Do not soak the lens in acid and alkali.

Never disassemble the product. It can result in exposure to laser radiation or an electric shock due to high voltage.

In the event a failure occurs in the system, contact us.

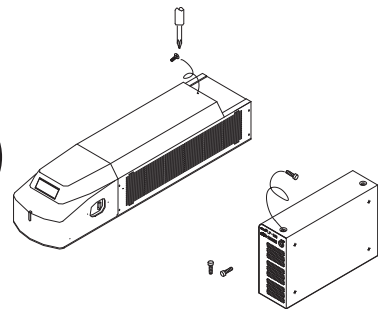

After the power supply of laser marker is turned off, laser safety manager must remove the system key and keep it.



Perform regular maintenance (cleaning, parts replacement) on this product. Using the product with dust or dirt may cause a fire or electric shock.

WARNING

Use this product neither in inflammable gas, a dusty place nor the place of fire strict prohibition. It might cause a fire.

Never put the object which is easy to burn on near. It might causes a fire.

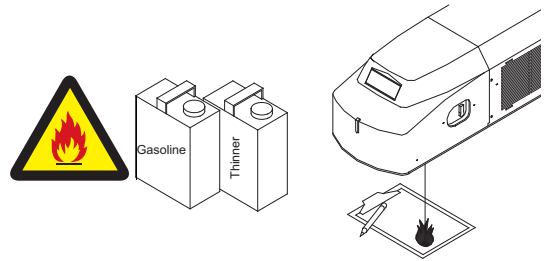

Construct an interlock systems such as a function to stop laser radiation for the maintenance door of the protective enclosure.

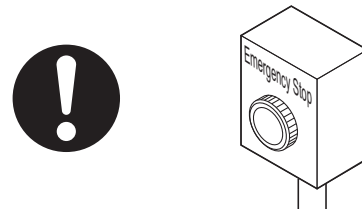

The air cooling system is used for this product as a laser cooling system. Please install not to bar the flow of air cooling. Moreover, please do not install a heat source in near, either.

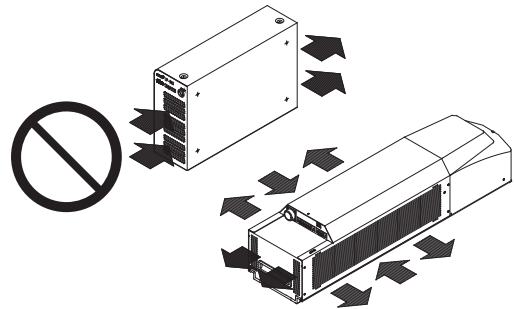

Since this product includes precision parts, please avoid vibration and use in a place with any shocks. Printing quality may deteriorate or the optical system may be affected. Moreover, please do not drop this product.

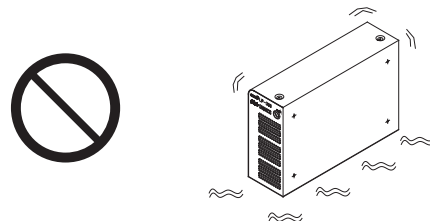

Be sure to connect the head to the exclusive controller. It will cause a failure if it connects with any equipment other than the exclusive controller. Moreover, it may be exposed to dangerous laser radiation.



While marking is carried out, dust and/or gas may be produced from the place to be marked. Always ventilate and remove them using a dust collector, etc.

Not collecting dust may affect the marking quality badly.

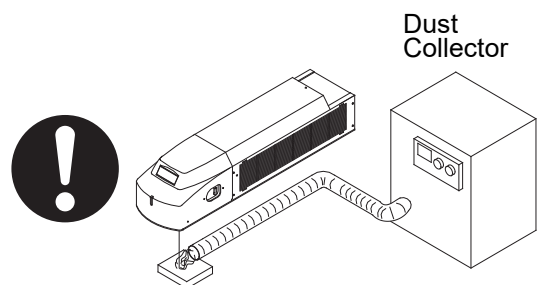

Be sure to observe the following matters to prevent a failure or a malfunction of this product and to maintain the product performance properly.

For the Proper Use of Product

When re-switching on the power supply, after turning OFF key switch of the power supply BOX supply and 5 seconds or more pass, turn ON key switch of the power supply BOX again.

When carrying the head part, carry the head part as shown in the right figure.

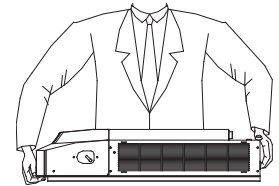

Clean air filter when it is dirty with dust etc. If the air filter is dirty, the air-flow might become bad and might stop marking operation. Exchange air filter periodically.

When the laser marker is not used for a significant period of time, be sure to save the back-up data of the laser marker files. During the unelectrified period, the battery for the back up will be out of charge and the data in the laser marker may be deleted.

Use the product with the below environmental condition:
Ambient temperature : 0 to +40 degrees C (no condensation)
Ambient humidity : 35 to 85% (no condensation)

Never let water, oil, fingerprints, dust garbage, etc. adhere to the lens part of the head. It might result in deterioration of marking quality, and failure. When cleaning, wipe with the dry soft cloth etc. lightly.

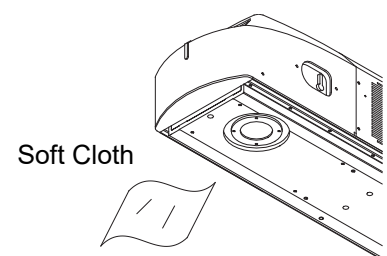

■ Applicable regulations and standards

This product meets the requirements mandated by the following regulations and standards according to the model. Note that our products do not conform to the regulations and standards of the countries and regions not mentioned in this section. When exporting the product by itself or integrated into machine or device, confirm the regulations and standards of the exporting country or region.

Model	Applicable regulations and standards
LP-310	JIS (Japanese Industrial Standards) • JIS C 6802
LP-310-A	FDA (Food and Drug Administration) Regulations • 21 CFR 1040.10 and 1040.11 (except for conformance with IEC 60825-1 Ed. 3, as described in Laser Notice No. 56 dated May 8, 2019)
LP-310-C	EN Standard (CE Marking) *1 • 2014/30/EU "EMC Directive" • EN 55011 • EN 61000-6-2 • 2014/35/EU "Low Voltage Directive" • EN 60204-1 • (partially applied *2) EN 61010-1 • EN 60825-1 • 2011/65/EU as amended by (EU)2015/863 "RoHS Directive" • EN IEC 63000 • EN 62321-1, EN 62321-2, EN 62321-3-1, EN 62321-3-2, EN 62321-4, EN 62321-5, EN 62321-6, EN 62321-7-1, EN 62321-7-2, EN 62321-8
	KC mark (Korea Certification) Class A Equipment (Industrial Broadcasting & Communication Equipment) This equipment is Industrial (Class A) electromagnetic wave suitability equipment and seller or user should take notice of it, and this equipment is to be used in the places except for home. A 급 기기 (업무용 방송통신기자재) 이 기기는 업무용 (A 급) 전자파적합기기로서 판매자 또는 사용자는 이 점을 주의하시기 바라며 , 가정외의 지역에서 사용하는 것을 목적으로 합니다 .

*1: Contact for CE:

Panasonic Marketing Europe GmbH, Panasonic Testing Center
Winsbergring 15, 22525 Hamburg, Germany

*2: Although EN 60204-1 is applied as a harmonized standard of LVD, EN 61010-1 is partially applied to enhance the conformity with electrical safety and requirement of LVD.

■ Other Cautions

1. Prior to wiring and/or cable connecting work, ensure that all the power has been turned off.
2. Use the accessory cables attached to the system for connecting cables without fail.
3. Be sure that the supplied power does not exceed the rating. Prior to turning the power on, check any change in voltage.
4. If a surge occurs in the power supplied, connect a surge absorber to a source of the surge to absorb it.
5. Make sure to ground a terminal of a frame ground (F.G.) of the system when using the device caused the noise around this product.
6. Install such that the housing of the power supply box and that of the head are at the same electric potential.
7. Since the ON/OFF operation of the key switch makes a load to the laser marker, do not turn OFF the power until completing the start of the system. Besides, leave an interval for at least 5 seconds from turning OFF the power to turning ON the power.
8. Note that the marked characters may be blurred if a CD cleaner or other liquid gets on the marked surface of the attached CD-ROM "LP-310 Setting Software".

■ Equipment Harnesses High Frequency Wave

Our CO₂ laser marker harnesses high frequency wave internally. Because the product has the mechanism generating laser, it is classified into “various equipment” in the equipment harnesses high frequency wave in Japan. Before using the product, please check whether the product is required to apply the similar law and regulation described above or not in user’s region/country, and if required, go through the required procedure(s) by the user.

■ Disposal of old equipment and batteries

Only for European Union and countries with recycling systems



These symbols on the products, packaging, and/or accompanying documents mean that used electrical and electronic products and batteries must not be mixed with general household waste.

For proper treatment, recovery and recycling of old products and batteries, please take them to applicable collection points in accordance with your national legislation.

By disposing of them correctly, you will help to save valuable resources and prevent any potential negative effects on human health and the environment.

For more information about collection and recycling, please contact your local municipality.

Penalties may be applicable for incorrect disposal of this waste, in accordance with national legislation.



Note for the battery symbol (bottom symbol)

This symbol might be used in combination with a chemical symbol. In this case it complies with the requirement set by the Directive for the chemical involved.

Refer to “Detaching Method of Battery” (P.20) for details.

◆ Detaching Method of Battery

The method for detaching the used battery installed in the laser marker to be disposed is described below in accordance with the EU Battery Directive (2006/66/EC).



- When detaching the used battery, be sure to disconnect the power cable so that the power shall not be supplied to the device.



- This method is never described with the replacing method of the battery. The battery is replaced by our service section. Please contact our sales office.
Note that the indication of the life duration of the battery might be 10 years.

1

Remove the rear cover of the head.

Remove 10 screws of the rear cover as shown in the figure below, and then slide the cover backward.

After removing the cover, the battery is installed in the position as shown in the figure below (surrounded with circle).

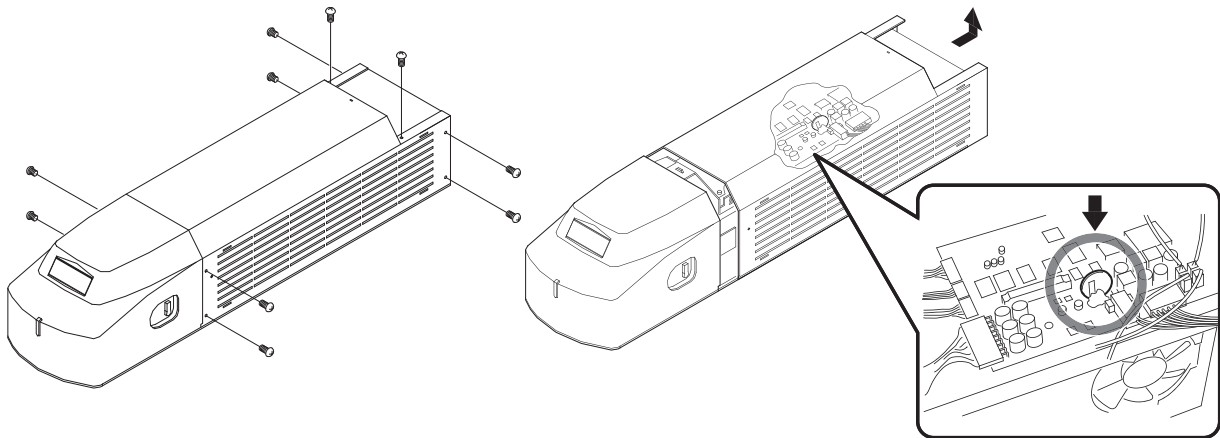

2

Remove the used battery.

Remove the adhesive used for enhancing the installation of the battery to the board using the nipper.

Then, cut the terminal of the battery one by one, and remove the battery from the board.

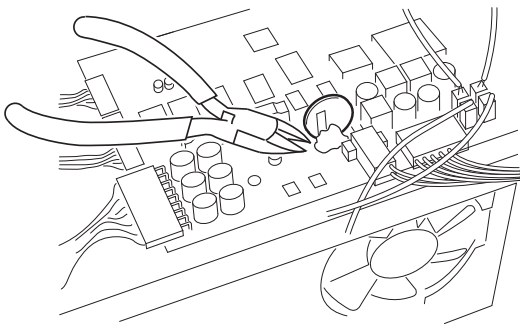

- Be sure to cut the terminal of the battery one by one. Cutting two terminals of the battery at the same time might cause the electrical shock.

MEMO

Contents

Preface.....	2
Cautions in Handling Laser Beam.....	6
Safety Protection Measures	8
Functions for Safety Measures	10
Cautions in Handling	15
Contents.....	22
Construction of Manual	27
1 Preparation	31
1-1 Package Check.....	32
1-2 Name of Each Part.....	34
1-2-1 Head.....	34
1-2-2 Power Supply BOX.....	35
1-3 Installation.....	36
1-3-1 Installation Method	36
1-3-2 Center of Marking.....	38
1-3-3 Useful Function for Installation	39
1-4 Connecting Laser Marker.....	40
1-4-1 Connecting Head and Power Supply BOX.....	40
1-4-2 Connecting Laser Marker and Personal Computer	41
1-5 Connecting with External Device	42
1-5-1 Operation Sample Using External Control Device	42
1-5-2 Operation Procedure Using External Control	43
1-5-3 Shift to Remote Mode.....	44
2 Basic Operation Procedure	45
2-1 When Using Laser Marker for the First Time	46
2-1-1 Preparation of Laser Marker Operation.....	47
2-1-2 Startup of Laser Marker.....	48
2-1-3 Procedure from Laser Marker Setting to Test Marking	49
2-1-4 Turn OFF Power of Laser Marker	57
2-2 Setting Procedure for Basic Function	58
2-2-1 Mark Counter.....	58
2-2-2 Mark Lot No.....	62
2-2-3 Mark Expiry Date.....	66
2-2-4 Mark Current Date.....	71
3 Description of Operation Screen	75
3-1 Description of Main Screen	76
3-1-1 Main Screen	76
3-1-2 Construction of Main Screen	78
3-1-3 Menu Function.....	79

3-1-4 Tool Button Function	81
3-2 File Selection	82
3-2-1 Marking File.....	82
3-2-2 Registration File	83
3-2-3 Registration File and Marking File.....	86
3-3 Character Setting.....	88
3-3-1 Character Setting Screen.....	88
3-3-2 Input of Marking Character.....	89
3-3-3 Input of Function Character.....	90
3-4 Function Setting.....	104
3-4-1 Function Setting Screen.....	104
3-4-2 Setting of Expiry Date Function.....	105
3-4-3 Setting of Counter Function	106
3-4-4 Setting of Lot Function	107
3-5 Marking Condition.....	110
3-5-1 Setting Screen of Marking Condition.....	110
3-5-2 General Conditions	111
3-5-3 Character Condition	115
3-5-4 CAD Condition	120
3-5-5 Laser Check.....	124
3-6 Laser Setting.....	126
3-6-1 Screen for Laser Setting	126
3-6-2 Line Width	127
3-6-3 Marking Pitch	127
3-6-4 Adjustment of Laser Start/End Points	128
3-6-5 Adjustment of Marking Quality	129
3-7 Image Display	130
3-7-1 Image Display Screen	130
3-7-2 Magnification Method.....	131
3-7-3 Adjustment of Marking Position.....	132
3-7-4 Adjustment of Display Position.....	133
3-8 Guide Indication.....	134
3-8-1 Center Position Indication	134
3-8-2 Guide Indication	134
3-8-3 Cautions	136
3-9 Test Marking	138
3-9-1 Test Marking	138
3-10 Send/Read.....	140
3-10-1 File Transmit	140
3-10-2 File List.....	142
3-10-3 Backup	142
3-10-4 Restore.....	143
3-11 PC Control/Remote Mode.....	144

3-11-1 Remote Mode.....	144
3-11-2 PC Control Mode.....	146
3-12 Switching Language between Japanese and English.....	147
3-13 Error History.....	148
3-14 Environmental Setting.....	150
3-14-1 Environmental Setting Related to Laser Marker.....	150
3-14-2 Environmental Setting Related to PC.....	152
4 External Control.....	155
4-1 Control Through I/O Connector.....	156
4-1-1 Before External Controlling Laser Marker Using I/O Connector.....	156
4-1-2 I/O Connector.....	157
4-1-3 Signal Name and Content of I/O Connector.....	159
4-1-4 Input Rating and Input Circuit.....	160
4-1-5 Output Rating and Output Circuit.....	161
4-1-6 Input/Output Operation.....	162
4-1-7 Timing Chart.....	164
4-2 Control with RS-232C.....	166
4-2-1 Before External Controlling Laser Marker Using RS-232C.....	166
4-2-2 RS-232C Connector.....	167
4-2-3 Specification for RS-232C.....	167
4-2-4 Setting of Communication Condition.....	168
4-2-5 Connecting Sample of External Control Device.....	168
4-2-6 Check Connection.....	169
4-2-7 Sample of Control.....	170
4-2-8 Communication Data Format.....	173
4-2-9 Communication Sequence.....	177
4-2-10 Communication Command and Function.....	180
5 Troubleshooting.....	186
5-1 Troubleshooting.....	187
5-2 Measures for Indicated Error.....	188
6 Maintenance.....	190
6-1 Maintenance.....	191
6-1-1 Contamination of f-theta Lens.....	191
6-1-2 Air Filter.....	191
6-1-3 Replacement of fuse.....	192
7 Specification.....	193
7-1 Specification.....	194
7-2 Outer Dimensional Drawing.....	195

7-2-1 Head.....	195
7-2-2 Power Supply BOX	196
Appendix	197
<hr/>	
Character Code Table.....	198
Readable DXF File.....	207
Glossary	209
Index	212
<hr/>	
Index	213

MEMO

Construction of Manual

Before Use	The important items for safety laser marker operation are described in this section. Be sure to read this section before using the laser marker.	P.2
Chapter 1 Preparation	This chapter describes the items required for using the laser marker. Be sure to read this chapter at preparation.	P.31
Chapter 2 Basic Operation Procedure	This chapter describes the basic operation targeting for the first user briefly. Since the control sample is also involved, refer to them together.	P.45
Chapter 3 Description of Operation Screen	Read this chapter for operating the laser marker such as the setting character to be marked and the function for marking.	P.75
Chapter 4 Control by External Device	This chapter describes the connecting method to the external control devices (such as PLC, device using external power supply). Read this chapter when connecting this product to the external device.	P.155
Chapter 5 Troubleshooting	This chapter describes the error messages and measures. Read this chapter when error message is appeared or marking is not performed properly.	P.186
Chapter 6 Maintenance	This chapter describes the maintenance, replacement of filter and cleaning of lens, etc. Please read this chapter when performing maintenance.	P.190
Chapter 7 Specification	This chapter describes the specification and outer dimension of laser marker.	P.193
Appendix	This appendix describes the character code table. With this table, the code of character and symbols to be marked can be checked.	P.197
Index	With this index, the corresponding page describing details for desired contents using the terms.	P.212

“Let’s Try” Contents

The user can refer to the corresponding pages in which the contents of what user “tries to do” are described using this “Let’s Try” Contents.

Setup Laser Marker

Install Setting Software

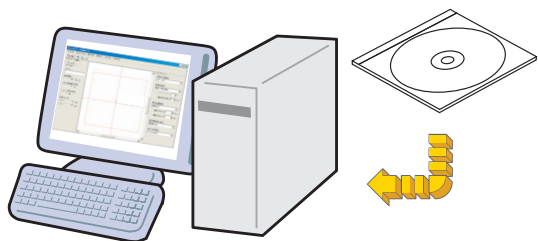

Install

Install and Connect

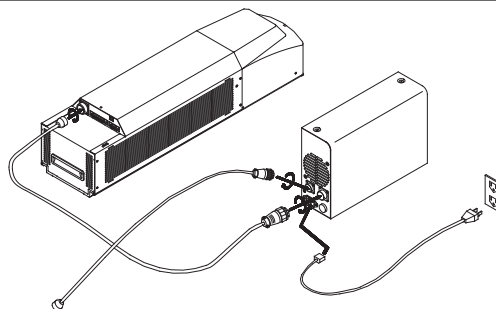

“Installation”

“Connecting Laser Marker”

Marking

Mark Date



“Input current date”

Mark Expiry Date

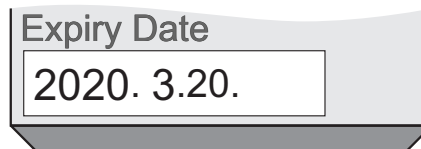

“Input expiry date”

“Setting of Expiry Date Function”

Mark Counter

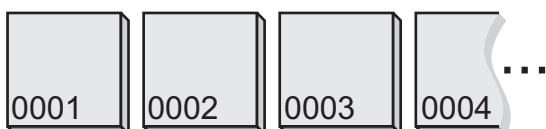

“Input counter”

“Setting of Counter Function”

Mark Lot

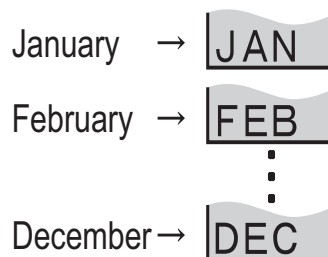

“Input lot”

“Setting of Lot Function”

Marking

Mark Logo

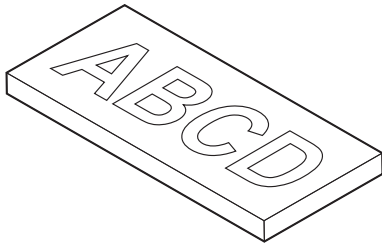

"CAD Condition" [P.120](#)

Set Character Condition

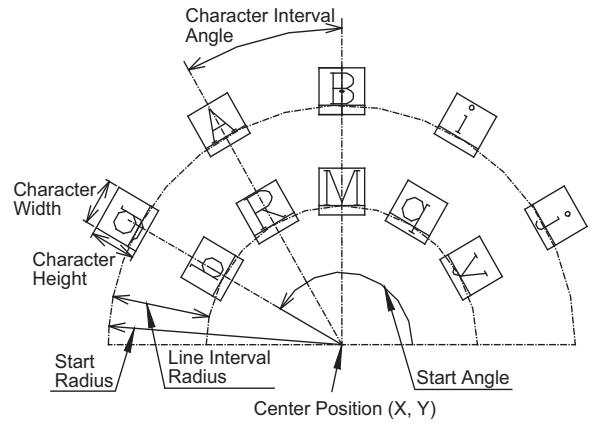

"Character Condition" [P.115](#)

Control Laser Marker From External Device

Control by I/O

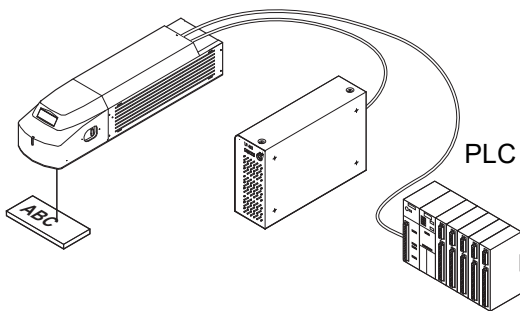

"Control Through I/O Connector" [P.156](#)

Control by RS-232C

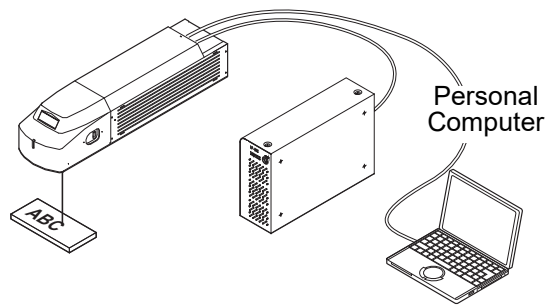

"Control with RS-232C" [P.166](#)

"Communication Command and Function" [P.180](#)

"Details of Commands" [P.180](#)

When in Trouble...



"Troubleshooting" [P.187](#)

"Measures for Indicated Error" [P.188](#)

MEMO

1 Preparation

1-1 Package Check	32
1-2 Name of Each Part	34
1-3 Installation	36
1-4 Connecting Laser Marker	40
1-5 Connecting with External Device.....	42

1-1 Package Check

Before using this product, be sure to check the packed objects shown below.



Be sure to store the packing material.
 Since this product is delicate one, apply the packing material that is used for this product for preventing from the failure caused by transferring.

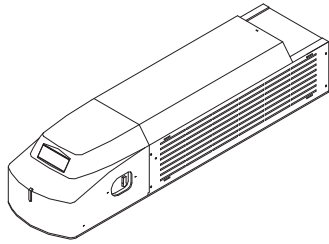

Head

1

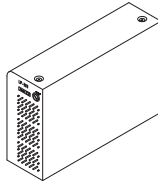

Power Supply BOX

1

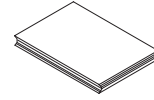

Installation Manual
for Setting Software
1

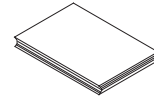

Operation Manual
(this manual)
1



Power Cable
for Head
1

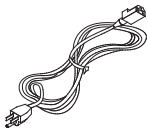

AC Power Cable *1
1

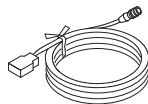

USB Cable
1



I/O Connector
1



I/O Connector Cover
1



System Key
2



Interlock Connector
1

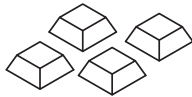

Rubber Foot for
Controller
4

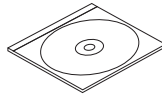

CD-ROM *2
1

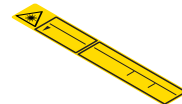

Warning, explana-
tory, aperture label
1

- *1
- LP-310/LP-310-A : Rated 125V, 3m
 - LP-310-C : Rated 250V, 3m

- *2 The following data is stored in CD-ROM.
- LP-310 PC Setting Software
 - PDF data of LP-300 series Operation Manual (Japanese / English / Chinese)
 - PDF data of PC Setting Software Installation Manual (Japanese / English / Chinese)

MEMO

1-2 Name of Each Part

1-2-1 Head

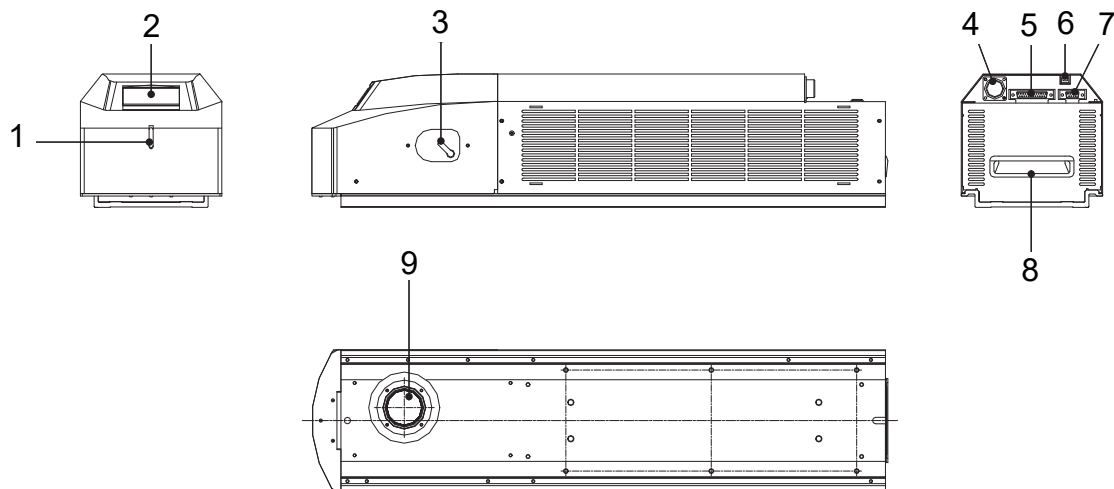

1. Laser Radiation Indicator

This indicator indicates the laser radiation state. (Refer to “Functions for Safety Measures” (P.10) for details.)

- Lights up in blue: Indicates while the power supply is ON.
- Lights up in red: Indicates the marking laser is radiated. Also this indicator flashes for 0.5 seconds just after turning on the power supply.

2. File No./Error Code Display (Head display panel)

The error code is displayed while there exists the file No. under marking and while an error is occurred.

- Rotation Display: Indicates the marking laser is under excitation.
- Normal : Indicates the file No. under marking.
- Under Error : Indicates the error code starting from the character “E”. (Refer to “5-2 Measures for Indicated Error” (P.188) for details.)

3. Shutter Lever (Guide Indication Switching Lever)

This shutter lever is used as the external shutter, and also is activated as the switching lever switching between guide indication laser and marking laser.

- OPEN : Set when radiating marking laser. Invalid for using guide laser.
- CLOSE : Blocks radiation of the marking laser. Indicates that the laser marker is in guide laser radiation state.

4. Power Connector

This is the connector for supplying power to the head. Connect the attached head power cable.

5. I/O Connector

This connector is used for controlling the head from external device. Connect the attached I/O connector.

To operate this laser marker, connect the following signals on I/O connector. For the details, refer to “4-1-2 I/O Connector” (P.157).

- Connect the power supply to [IN COM.] (pin No.14) and to [OUT COM.] (pin No.15) respectively.
- Connect [LASER STOP] (pin No.4) and [OUT COM.] (pin No.15) to release the laser stop function.

6. USB Connector

This connector is used when the data set on the PC is required transferring to the laser marker itself.

7. RS-232C Connector

This RS-232C connector is used for controlling the laser marker using the communication from the external device.

8. Handle

This part can be used for carrying the head of the laser marker. This product can be carried with both hands using this handle and the uneven part on the front side.

9. Radiation Nozzle of Laser and Guide Laser

This is the part from which the marking laser and guide laser are radiated. Do not block off the radiation nozzle when installing this product.

Also, this part is manufactured with $f\theta$ lens.

1-2-2 Power Supply BOX

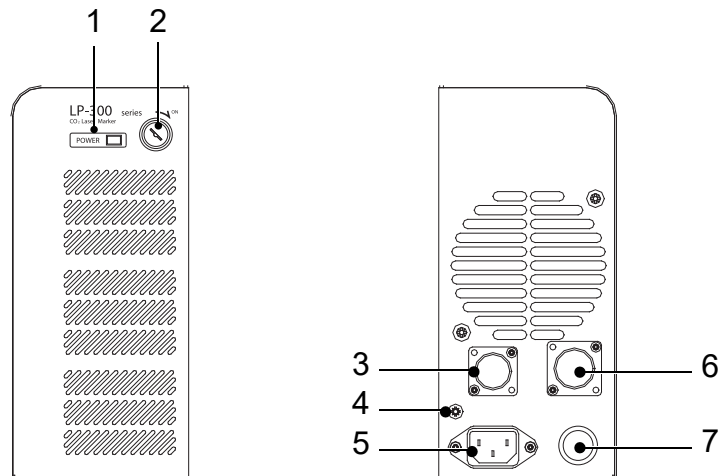

1. Main Power Indicator

This indicator lights up in green when turning ON the key switch, indicating the power is supplied.

2. Key Switch

This is the key switch for starting up the laser marker.

ON : Impossible to remove key switch

OFF : Possible to remove key switch

When turning OFF the power supply (not activating laser marker), remove the key switch, and the removed key switch shall be kept by the laser safety manager.

3. Interlock Connector

Use this part as the interlock connector to build up the interlock system. Removing this connector stops supplying the power to the laser of the head.

(Opening both Pin 1 and Pin 3 stops the power, and connecting these pins supplies power.)

4. Frame Ground: F.G.

This is the terminal for grounding.

Be sure to ground this product either by this terminal or earth terminal of the inlet.

5. Inlet

With this inlet, the AC power supply is connected. Use the attached AC power cable.

90V to 132V AC or 180V to 264V AC (including +/-10% voltage fluctuations), 50/60Hz (Voltage and frequency are switched automatically.)

The voltage of the attached AC power cable is 125V rating for LP-310/310-A, 250V rating for LP-310-C.

Be sure to connect the ground pin of the AC power cable to earth permanently.

6. Power Connector

This is the connector for supplying power to the head. Connect the attached head power cable.

7. Fuse

This is the fuse for protecting this product from overcurrent.

1-3 Installation

1-3-1 Installation Method

(1) Installation Method

Head

This head can be fixed from the bottom with M6 screw at six locations.



- The inserting length of the screw shall be 10mm or less.
- The tightening torque shall be 2.0N•m or less.

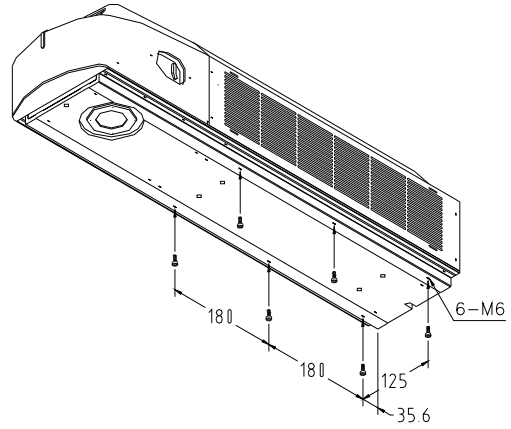

Power Supply BOX

This power supply BOX can be fixed from the bottom with M4 screw at four locations.



- The inserting length of the screw shall be 10mm or less. Note that the inserting length of the screw on side surface of LP-310-C shall be 5mm or less.
- The tightening torque shall be 2.0N•m or less.

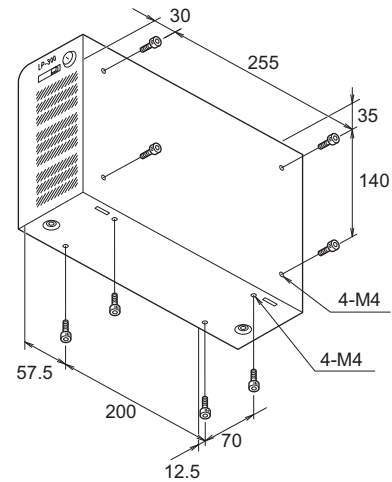

(2) Installation Direction

For making use of the laser marker safely and fully, install the laser marker in either direction shown below:

Head

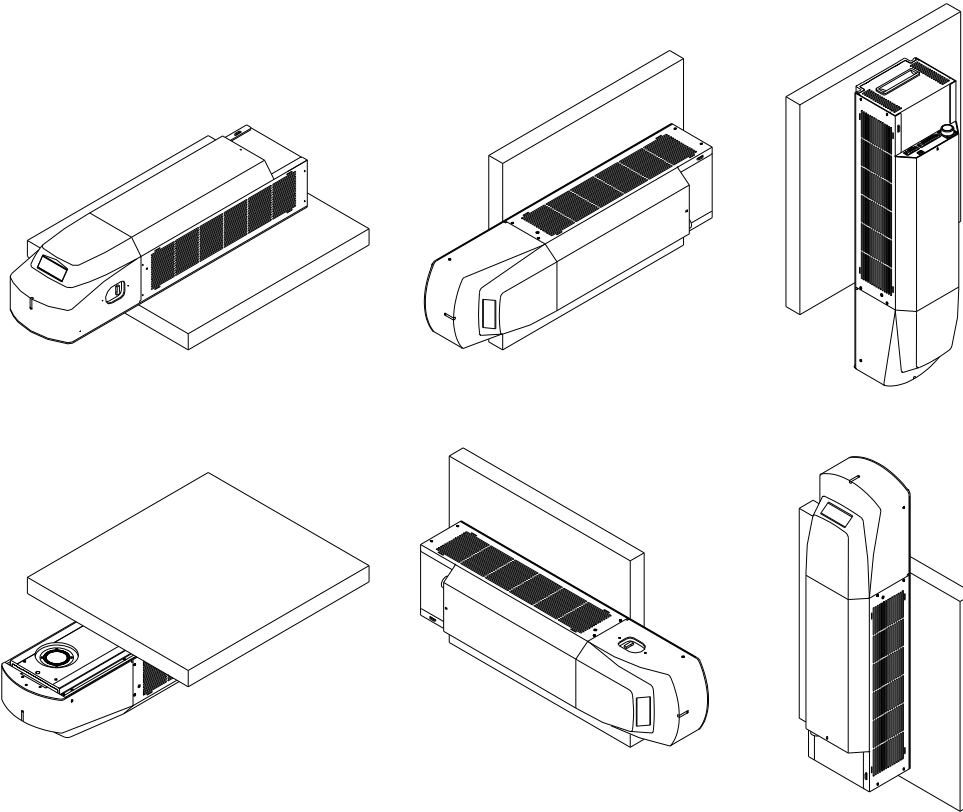

Do not incorporate the laser marker in a unit where the laser head will be moved. It may cause failure.

Power Supply BOX

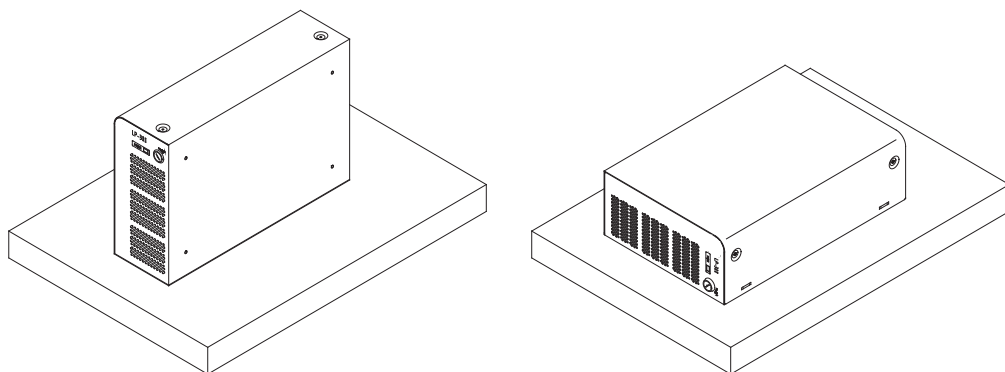

(3) Installation Space

Since this product is operated by the forced air-cooling, both fan and slit for cooling are equipped. Make space around the product as shown in the following figure.

Head

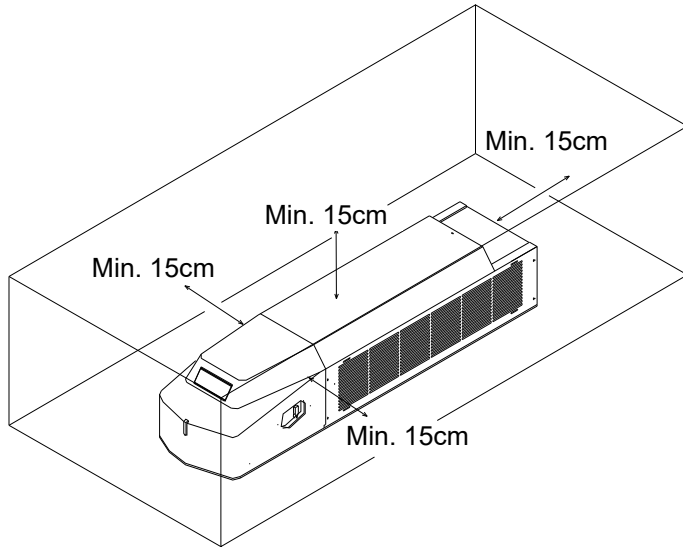

Power Supply BOX

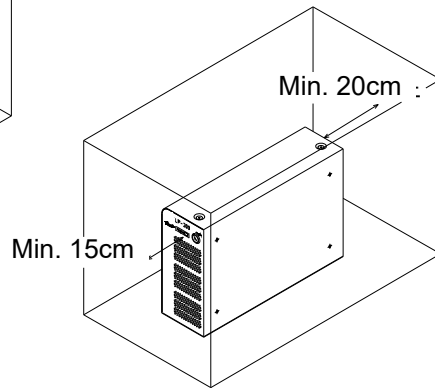

1-3-2 Center of Marking

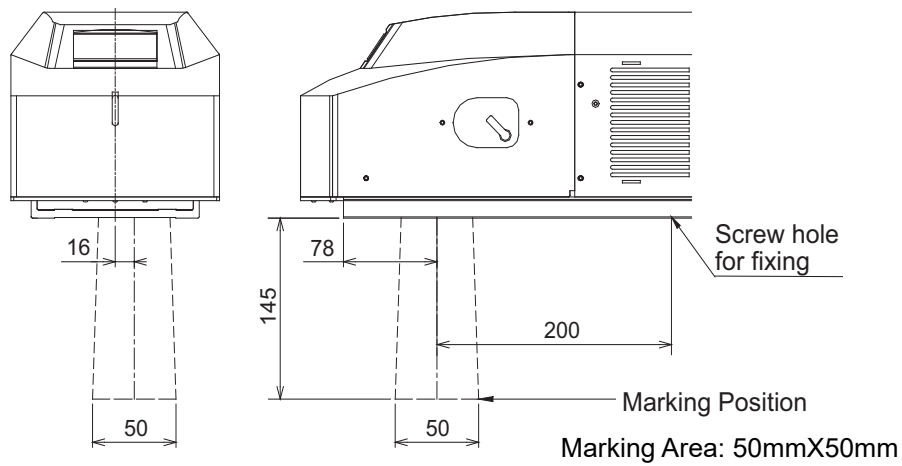

1-3-3 Useful Function for Installation

■ Guide Laser Function

The marking contents and marking area can be traced with the red guide laser. By using the guide laser function, the position adjustment of the marking is available easily.

Refer to “3-8 Guide Indication” (P.134) for details of the operating method.

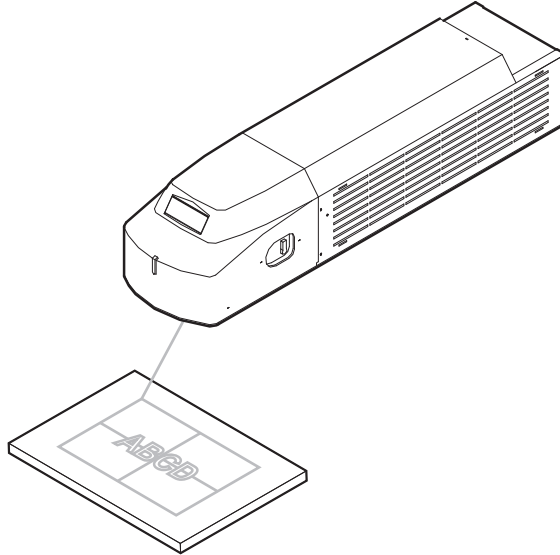

1-4-1 Connecting Head and Power Supply BOX

Connect the following items using the attached specific cables.

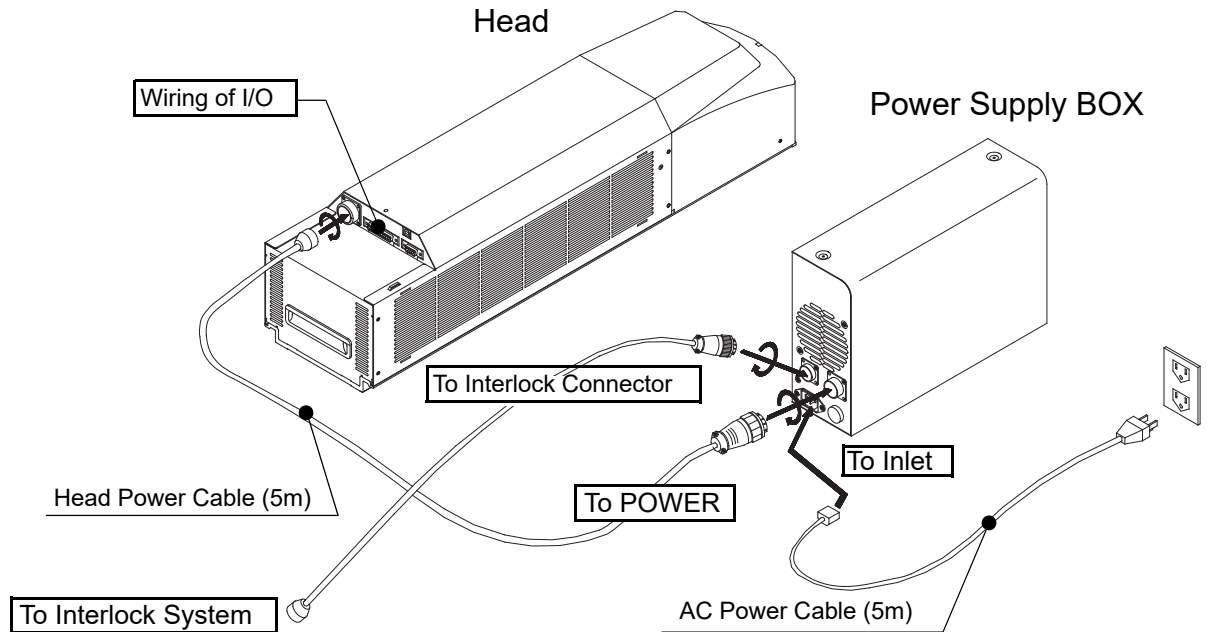

- Connect the items above using the attached specific cables.
 - For the connectors location, refer to “1-2-1 Head” (P.34) and “1-2-2 Power Supply BOX” (P.35).
 - Attached AC power cable varies depending on each model. Please select a cable suitable for the standards in the country or region where it is used.
1. Perform the connection of the AC power at the end. Do not insert or pull cable with the power in supplied state.
 2. Pay attention to the power source so as not to occur noise with enough.
 3. Set each connecting cable away from the device that generates high voltage, power line, and large switching surge as far as possible.
 4. If any noise is occurred on the power source, use the noise cut-off transducer.
 5. Be sure to ground the F.G. (frame ground) terminal. Refer to “1-2-2 Power Supply BOX” (P.35) for the terminal position.
 6. Fix the connector with screws securely so as not to drop it.
 7. To operate this laser marker, connect the following signals on I/O connector. For the details, refer to “4-1-2 I/O Connector” (P.157).
 - Connect the power supply to [IN COM.] (pin No.14) and to [OUT COM.] (pin No.15) respectively.
 - Connect [LASER STOP] (pin No.4) and [OUT COM.] (pin No.15) to release the erroneous irradiation prevention function for the laser.



1-4-2 Connecting Laser Marker and Personal Computer

Connect the following items using the attached specific cables.

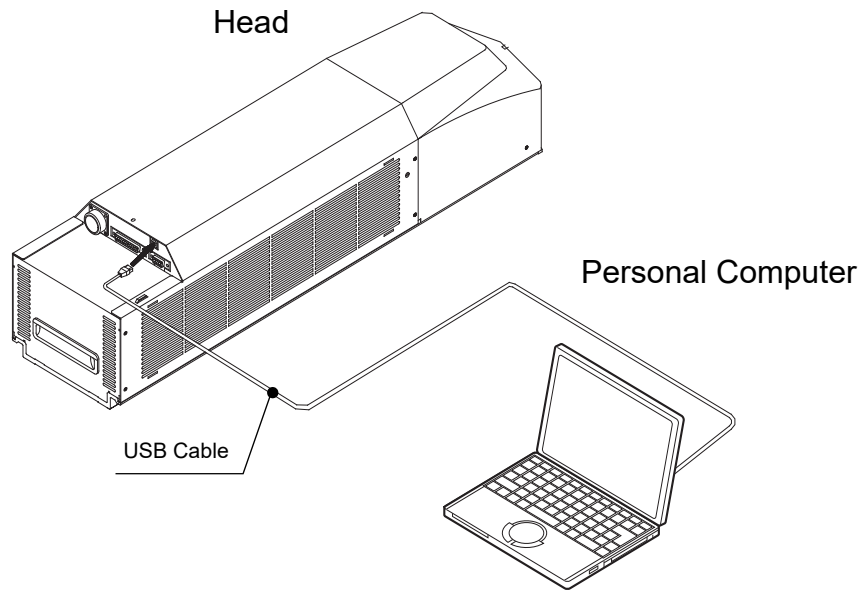

The function that several LP-310s are operated with only one personal computer is not incorporated.

1-5-1 Operation Sample Using External Control Device

In case of controlling the laser marker with the external control device, the following two connecting methods are applicable.

1. External Control Using I/O Connector (Remote mode)

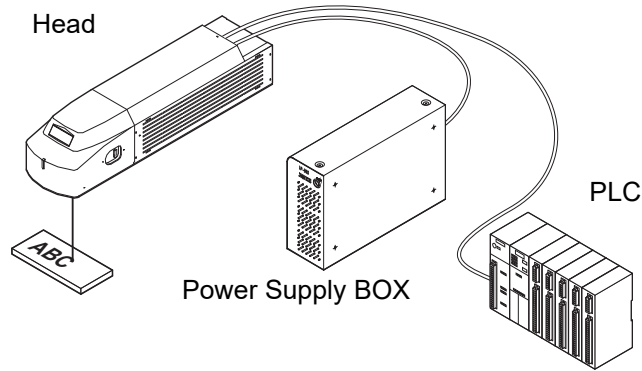

2. External Control Using RS-232C (Remote mode)

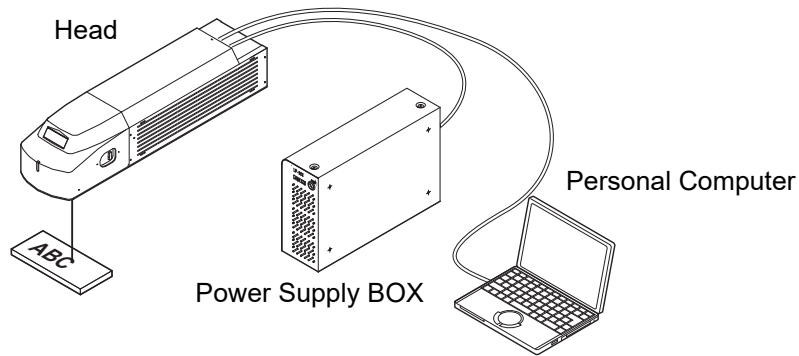

<Reference> Test Marking (PC control mode)

Other than external control, the test marking can be performed using the personal computer.

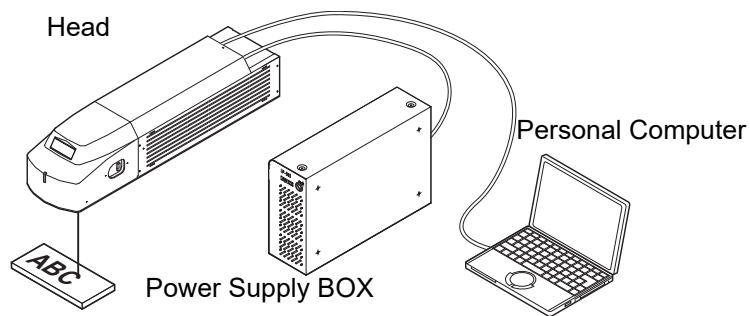

1-5-2 Operation Procedure Using External Control

This section describes the basic operation procedures using the external control.

■ Flow Chart

* The procedure marked with  is performed by manual.

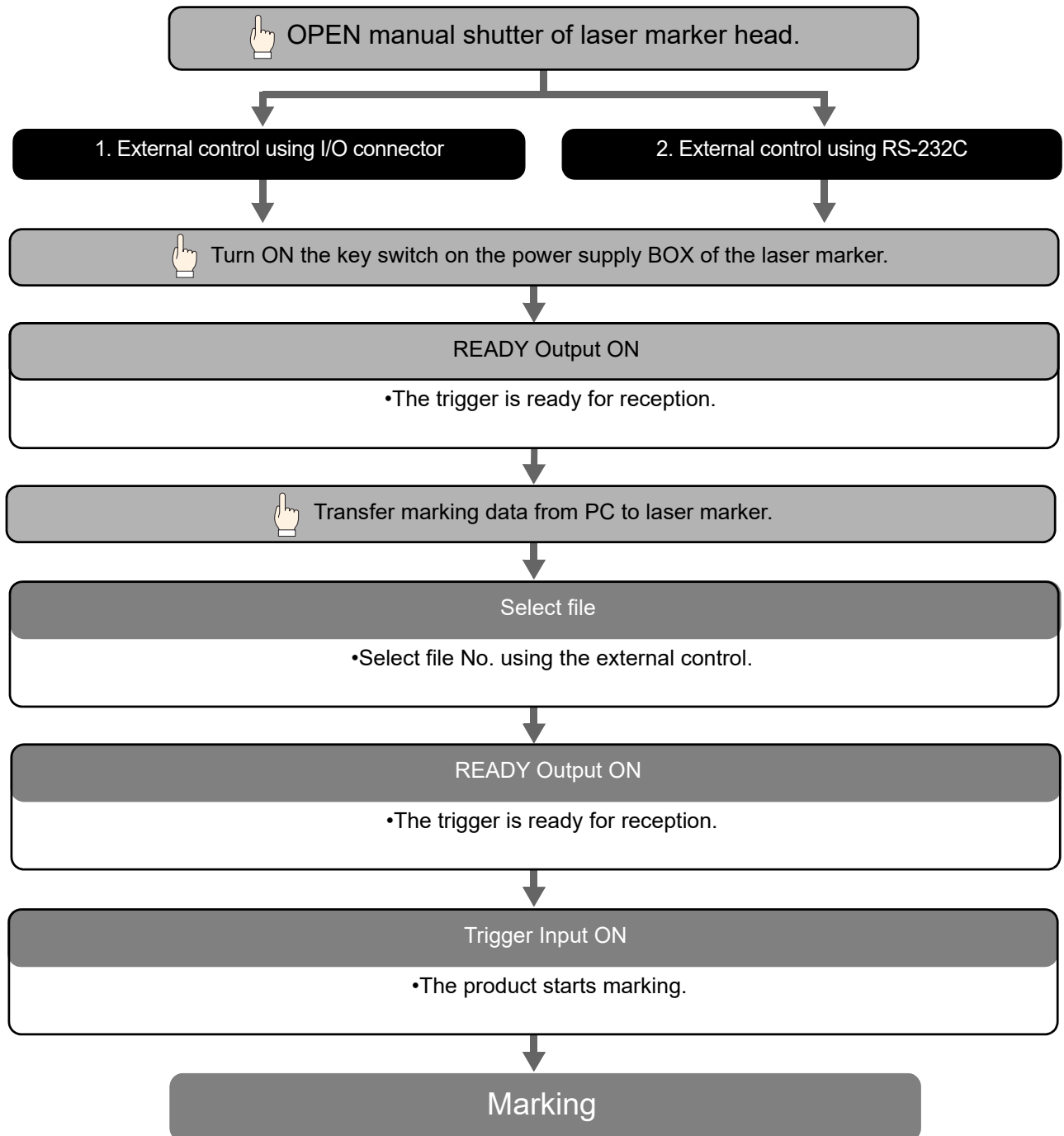

- There are two modes, personal control mode and remote mode for this product. The switching of the mode between personal control mode and remote mode is set with the personal computer. When turning on the power supply of this product, the remote mode is activated.

1-5-3 Shift to Remote Mode

In case of controlling the terminal block using the external device such as I/O connector and RS-232C, it needs to shift the laser marker to "Remote Mode". Before performing the external control by either method show below, shift the laser marker to remote mode.

1. Turn ON the key switch of the power supply BOX.

When turning ON the key switch, the product is in remote mode automatically.

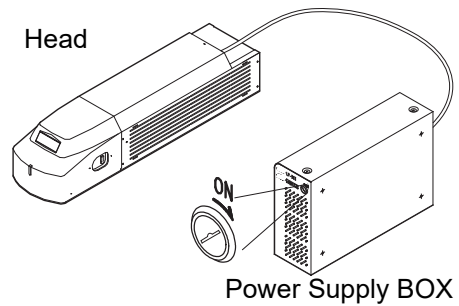

2. Switch the mode of the product from the PC control mode to remote mode using the personal computer.

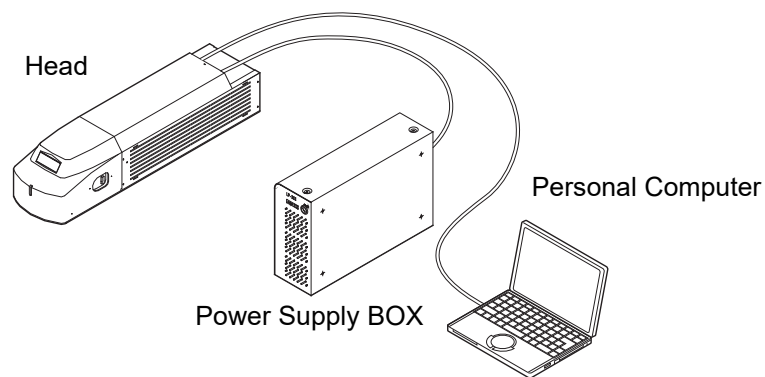

2 Basic Operation Procedure

2-1 When Using Laser Marker for the First Time	46
2-2 Setting Procedure for Basic Function.....	58

The procedure for using the laser marker for the first time after purchasing from performing test marking the character (sample show below) until turning off the power supply is described below.

■ Sample

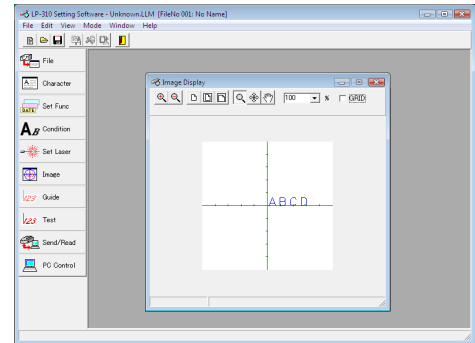
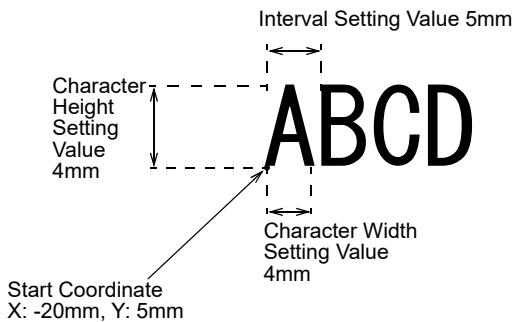

The position and size of the character to be marked are set as follows:

Start Coordinate X	: -20mm, Y: 5mm	Laser Power	: 30
Character Height	: 4mm	Scanning Speed	: 300
Character Width	: 4mm		
Character Interval	: 5mm		

* The actual marked character size is differed from the setting character height and character width. Refer to “3-5-3 Character Condition” (P.115) for details.

■ Flow Chart

1. Preparation of laser marker operation.

- (1) Package Check
- (2) Installation of Laser Marker
- (3) Installation of “LP-300 series PC Setting Software” to PC
- (4) Connecting Laser Marker

The details of these procedures are described in “2-1-1 Preparation of Laser Marker Operation” (P.47).

2. Startup of laser marker operation1.

The detail of this procedure is described in “2-1-2 Startup of Laser Marker” (P.48).

3. Procedure from Laser Marker Setting to Test Marking

- (1) Set the file to be marked.
- (2) Input the character to be marked.
- (3) Set the marking condition.
- (4) Set the laser.
- (5) Perform test marking in personal control mode from the personal computer.
- (6) Save setting contents.

The detail of these procedures are described in “2-1-3 Procedure from Laser Marker Setting to Test Marking” (P.49).

Turn off the power of the laser marker.

The detail is described in “2-1-4 Turn OFF Power of Laser Marker” (P.57).

2-1-1 Preparation of Laser Marker Operation

1

Check the package.

Check the package referring to "1-1 Package Check" (P.32).

If something is lack, as for the nearest sales office.

2

Install the laser marker.

Install the laser marker referring to "1-3 Installation" (P.36).

3

Install "LP-300 series PC Setting Software" stored in the attached CD-ROM to the PC.

Refer to the "Installation Manual" for the procedures.

4

Connect the laser marker.

Connect the laser marker referring to "1-4 Connecting Laser Marker" (P.40).

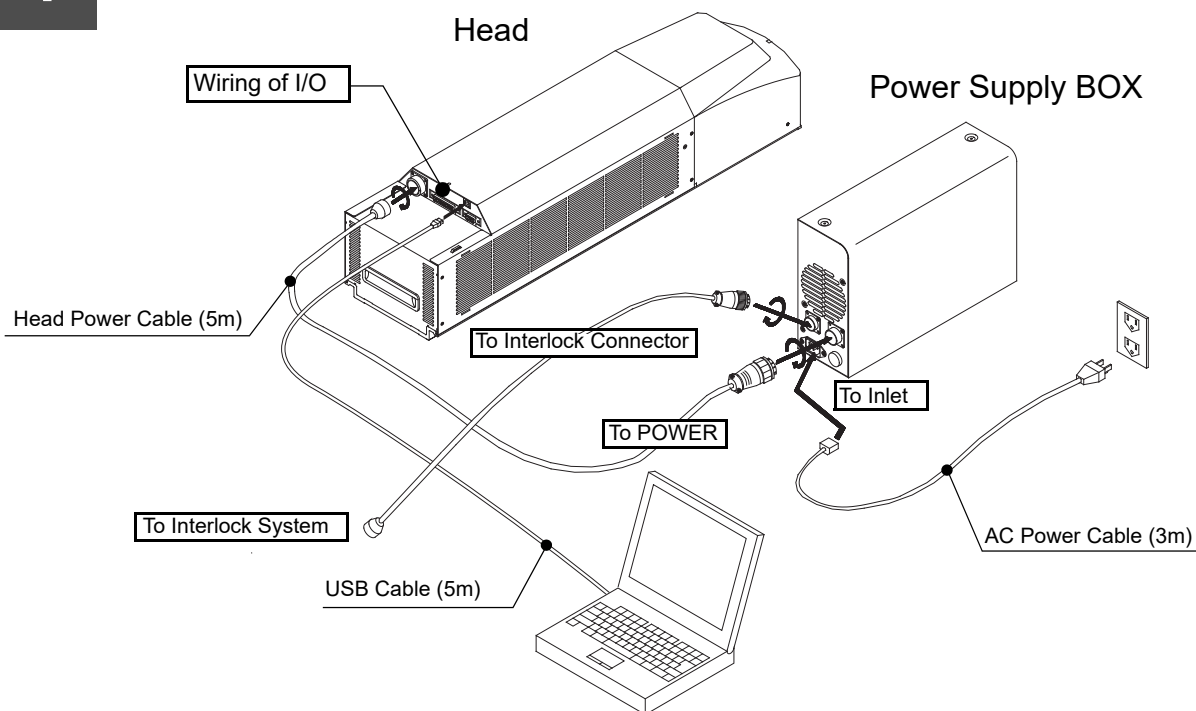

To operate this laser marker, connect the following signals on I/O connector. For the details, refer to "4-1-2 I/O Connector" (P.157).

- Connect the power supply to [IN COM.] (pin No.14) and to [OUT COM.] (pin No.15) respectively.
- Connect [LASER STOP] (pin No.4) and [OUT COM.] (pin No.15) to release the erroneous irradiation prevention function for the laser.

2-1-2 Startup of Laser Marker

1

Turn ON the key switch of the power supply BOX.

(Insert the key and turn it toward ON side.)

The laser radiation indicator lights up in red for approx. 0.5 seconds, and then it changes the lit color into blue.

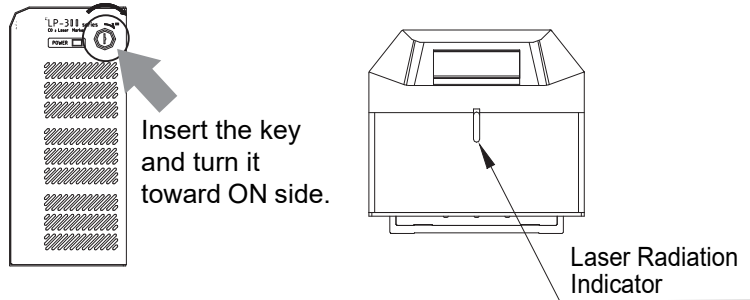

CHECK

Turn ON the key switch of the power supply BOX after connecting the laser marker to the personal computer using USB.



REFERENCE

Since the ON/OFF operation of the key switch puts load to the laser marker, do not turn off the power supply until completing the system start.
Besides, in case of turning ON the power supply after turning OFF, leave the interval at least 5 seconds between ON and OFF.

2-1-3 Procedure from Laser Marker Setting to Test Marking

1. Set the file No. to be marked.

The "File Selection" screen is displayed when starting the PC setting software.

1

Select the File No. "003" on the file selection screen.

Pressing File No. 003 highlights the comments column, and "003" is selected.

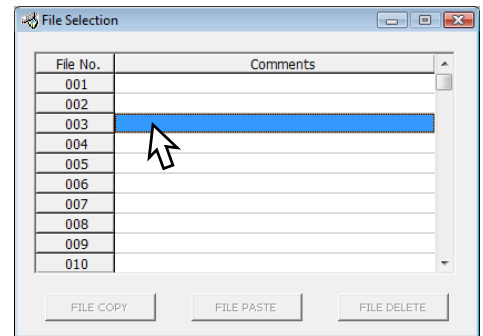

2

Input the file name into the [Comments].

Here inputs the "Product A" into the comment. (Input the character using the keyboard of the PC.)

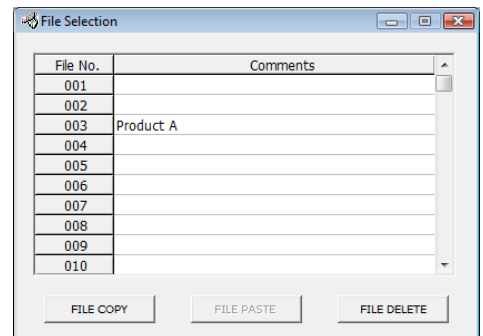

2. Input the character to be marked.

1

Press **A_B** Condition .

The screen is changed into "Character Setting" one.

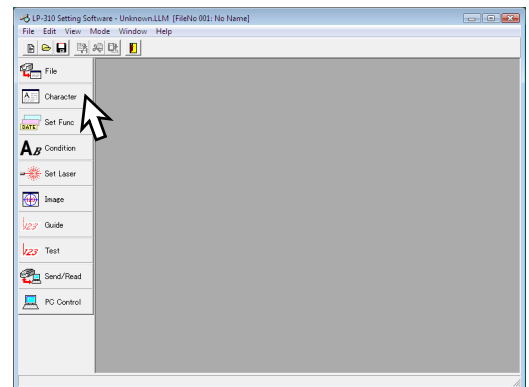

2

Adjust the cursor to the first line "01" of the screen, and press **EDIT** .

* Re-adjusting the cursor to the first line (01) and then pressing (double-clicking) the same cursor performs the same operation.

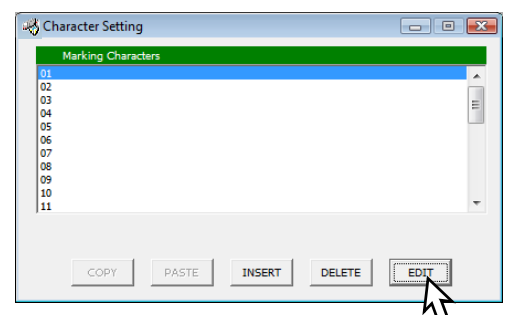

3

The screen is changed into "Inputting Of Characters".

Here inputs "ABCD".
(Input the character using the keyboard of the PC.)

*In case of operating under Japanese OS, input the double-byte character.

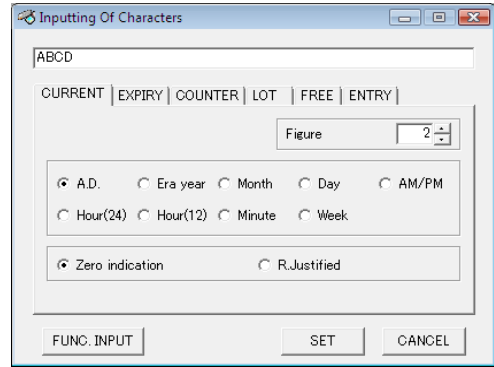

4

Press **SET**.
Here inputs "ABCD".
(Input the character using the keyboard of the PC.)

The character "ABCD" is input.

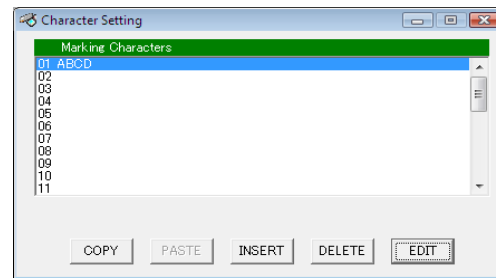
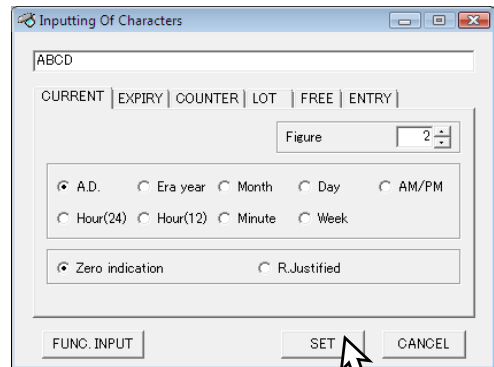

3. Set the marking condition.

Here describes the procedure for setting marking conditions using the following sample, character height: 4mm, character width: 4mm, X position: -20mm, Y position: 5mm, and character interval: 5mm.

1

Press **A_B Condition**.

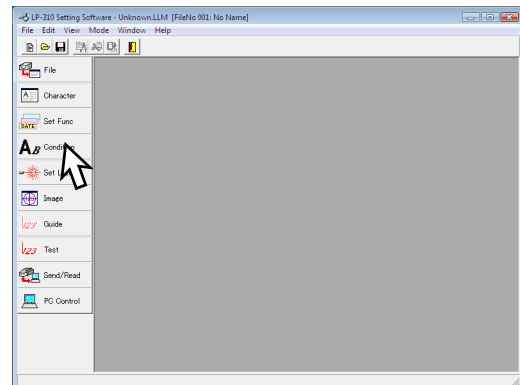

2

Press **CHARACTER**.

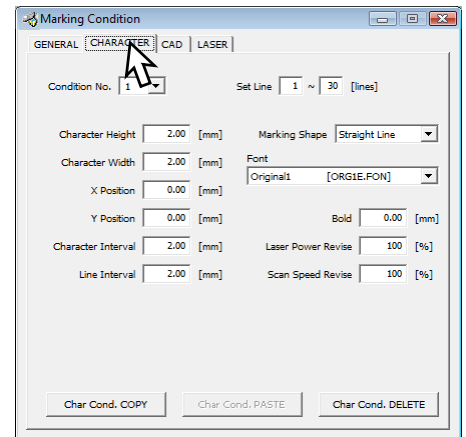

3

Press the setting value of the [Character Height].

Input "4".

(Input the value using the keyboard of the PC.)

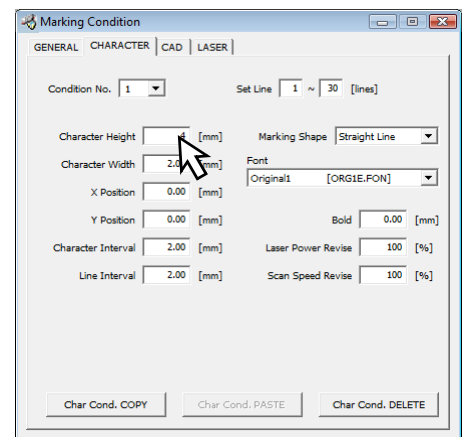

4

Press the setting value of the [Character Width].

Input "4".

(Input the value using the keyboard of the PC.)

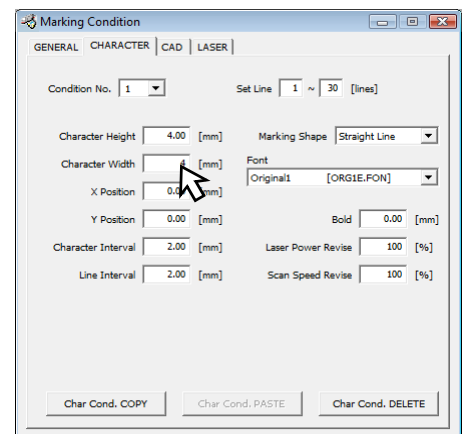

5

Press the setting value of the [X Position].

Input "-20".

(Input the value using the keyboard of the PC.)

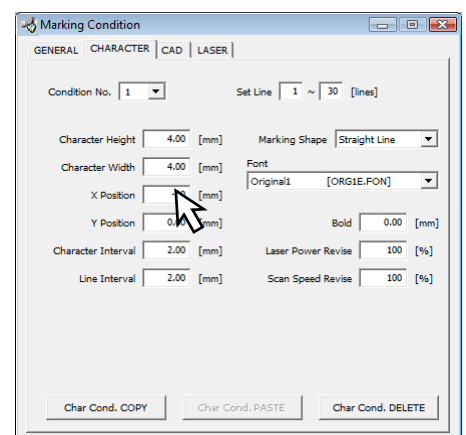

6

Press the setting value of the [Y Position].
Input "5".
(Input the value using the keyboard of the PC.)

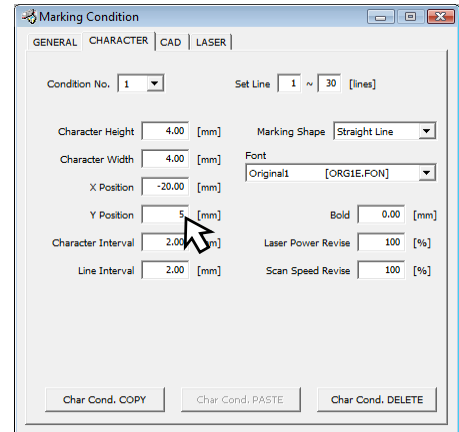

7

Press the setting value of the [Character Interval].
Input "5".
(Input the value using the keyboard of the PC.)

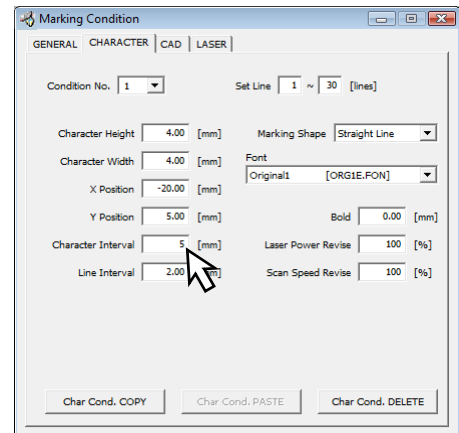

8

Press [Image], and check the image screen.

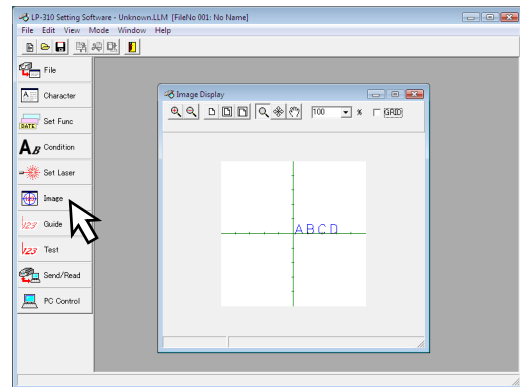

4. Set the laser.

Here describes the procedure for setting laser power at 30 and scan speed at 300mm/s.

1

Press  Set Laser .

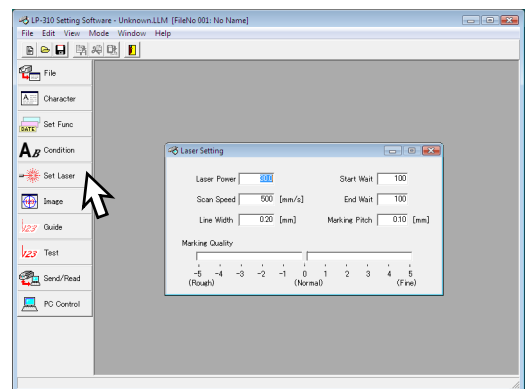

2

Press setting value of the [Laser Power].
Input "30".
(Input the value using the keyboard of the PC.)

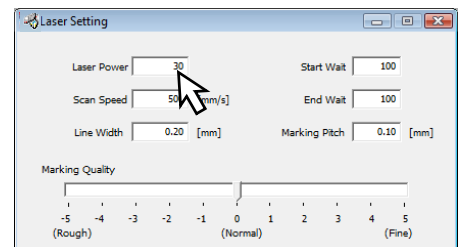

3

Press setting value of the [Scan Speed].
Input "300".
(Input the value using the keyboard of the PC.)

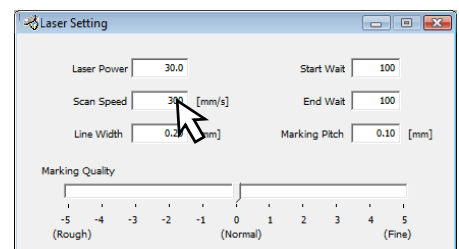

5. Perform test marking from PC in PC control mode.

1

Set the work to be marked and adjust the distance between the laser marker and the work.

Set the distance from the lower surface of the scanning unit of the head to the surface of the work to be marked at 145mm.

2

Set the shutter lever to "CLOSE".

3

Press either  Guide (Fig. A) or pull down "File" - "GUIDE" (Fig. B).

A

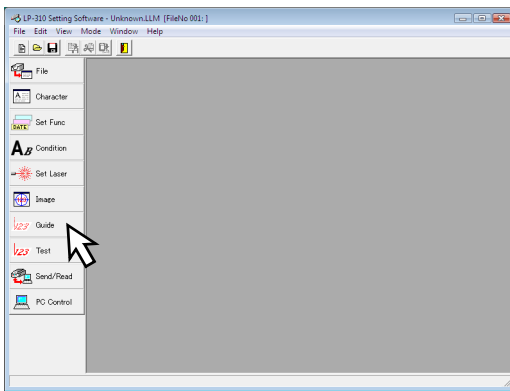

B

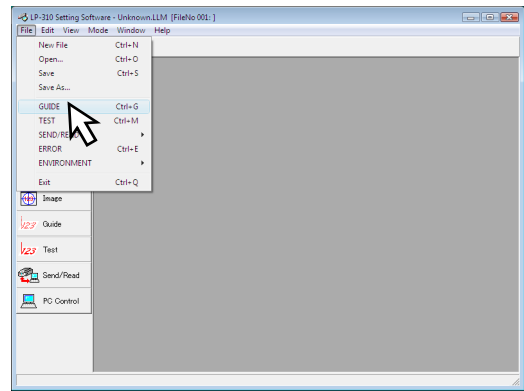

If the shutter is in OPEN state, the dialog notifying that the shutter is already in OPEN state is appeared. Click "OK", set the shutter into "CLOSE", and then select either procedure A or procedure B.

4

Press "Series" on the [Start of guide indication] dialog box.

Here the guide indication is activated in "Series" with the laser marker.

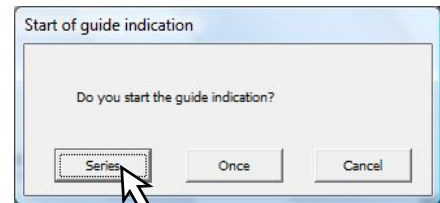

If the file No. under editing on PC is also existed on the head, the overwriting confirmation dialog box shown in the right figure is displayed. (If the same file No. is not existed in the head, the overwriting confirmation dialog box is not displayed.)

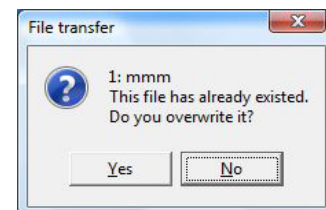

5

When selecting “Yes”, the file is transferred to the laser marker, and the guide indication with red laser is started.

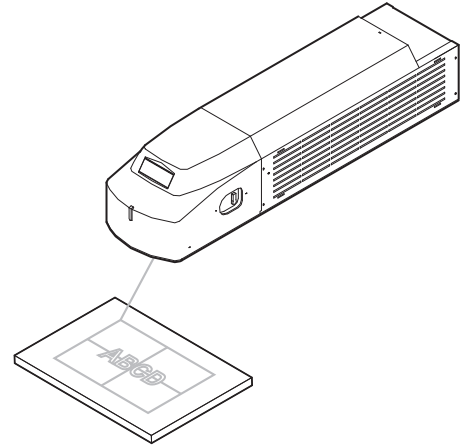
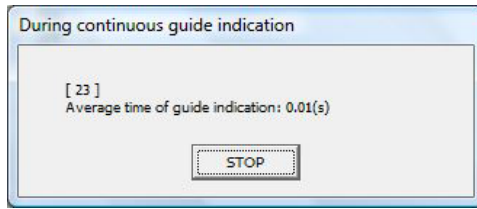

Adjust the marking position by moving the work to be marked or other method.

6

When clicking the “STOP” button, the dialog box shown in the right figure is displayed.

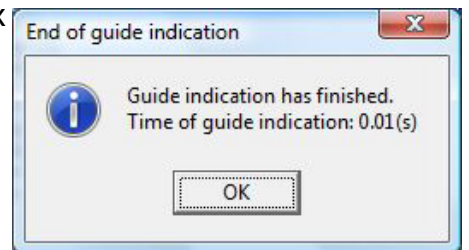

After completing the guide indication, the dialog box “During continuous guide indication” is closed, and the “End of guide indication” dialog box is displayed. Besides, the time of guide indication is displayed.

7

Set the shutter lever to “OPEN”.



The laser is radiated. Be sure to use the protection goggle and enclosure while working.

8

Press either  Test (Fig. A) or pull down “File” - ”TEST” (Fig. B).

A

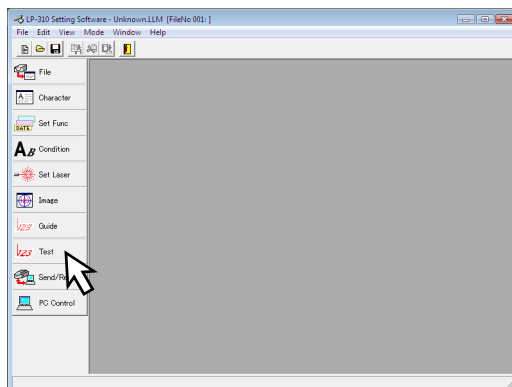

B

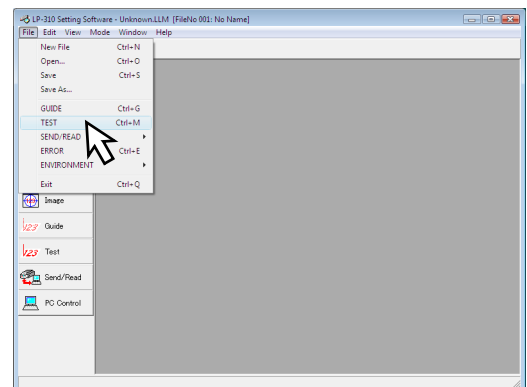

If the shutter is in CLOSE state, the dialog that notifies the shutter is already in CLOSE state is appeared. Click “OK”, set the shutter into “OPEN”, and then select either procedure A or procedure B.

9

When selecting “Yes” on [Start of printing] dialog box, the file is transferred to the laser marker, and the marking is started.

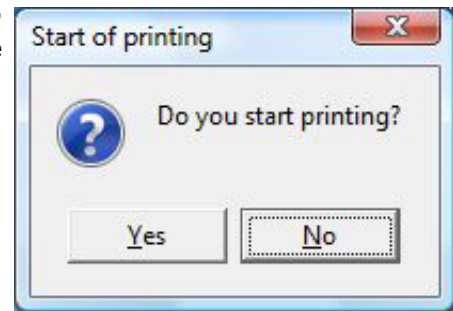

If the file No. under editing on PC is also existed on the head, the overwriting confirmation dialog box shown in the right figure is displayed. (If the same file No. is not existed in the head, the overwriting confirmation dialog box is not displayed.)

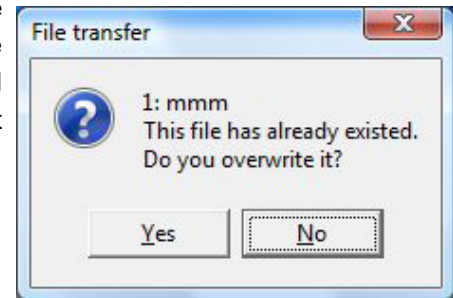

After completing the marking, the “End of printing” dialog box is displayed. Besides, the marking time is displayed.

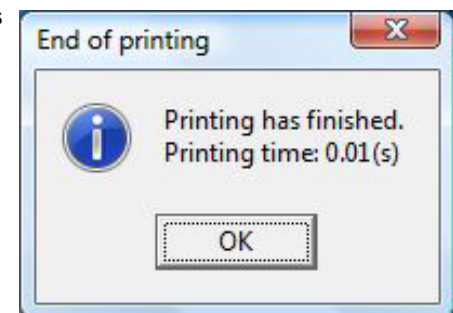

6. Save the setting contents.

Here describes the procedure for saving the setting file conditions to PC.

1

When selecting "File" - "Save As", the dialog for setting file name is appeared.

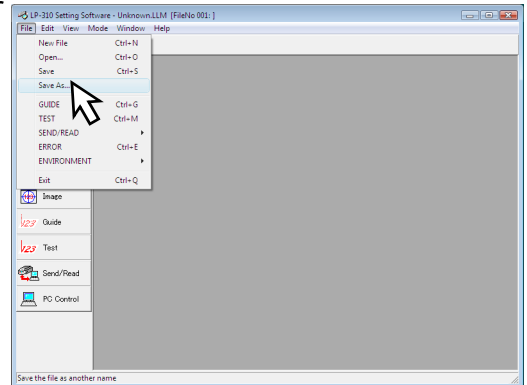

2

Set the file name and saving place, and press "Save".

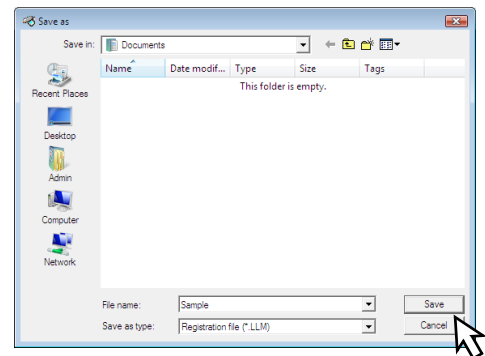

2-1-4 Turn OFF Power of Laser Marker

1

Turn OFF the key switch of the power supply BOX.
(Turn the key toward OFF, and pull it out.)
The laser radiation indicator is lit off.

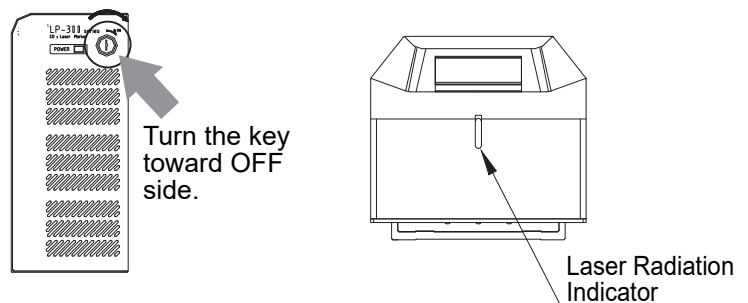

- When not using the laser marker, pull out the key switch and store it under the control of the laser safety manager in charge of controlling the laser marker.
- When the laser marker is not used for a significant period of time, be sure to save the back-up data of the laser marker files. During the unelectrified period, the battery for the back up will be out of charge and the data in the laser marker may be deleted.

The setting method for function to be applied to the actual marking is described in this section using sample.

2-2-1 Mark Counter

■ Sample

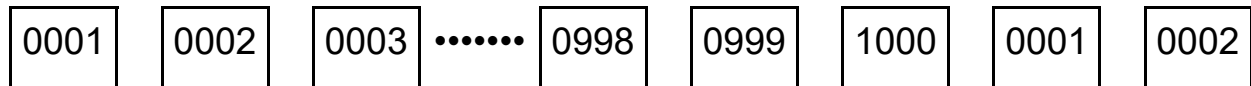

Set the counter shown above.

■ Flow Chart

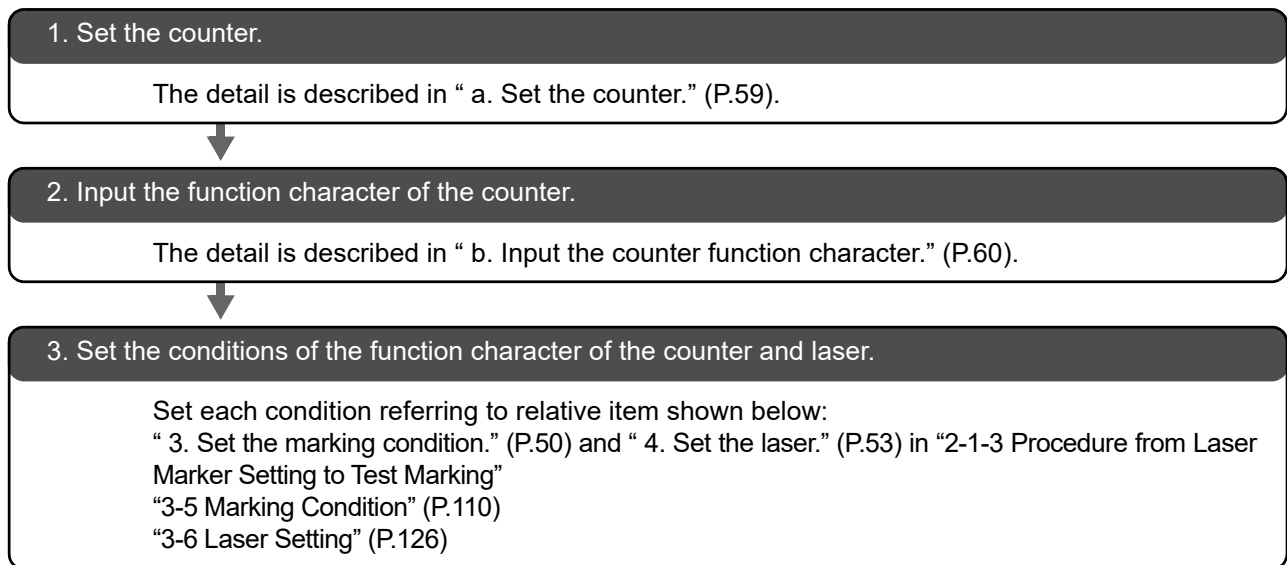

a. Set the counter.

Refer to “3-4-3 Setting of Counter Function” (P.106) for detail setting.

1

Press , and press “COUNTER”.

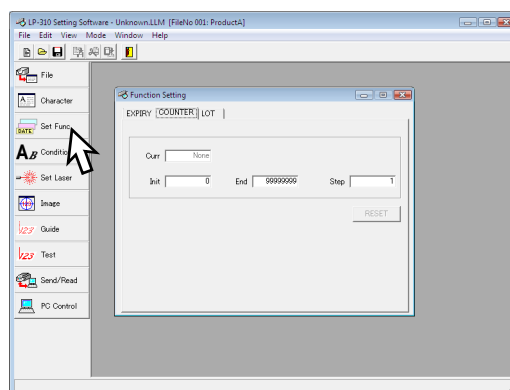

2

Set “1” to [Init (Initial value)].
Input the numeric using the keyboard of the PC.

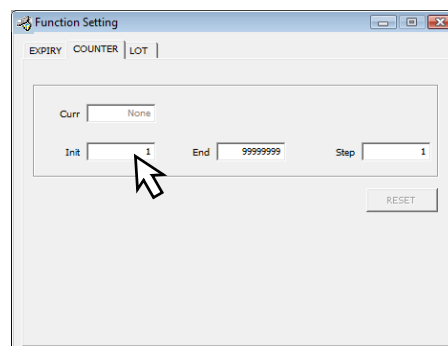

3

Set “1000” to [End (End value)].
Input the numeric using the keyboard of the PC.

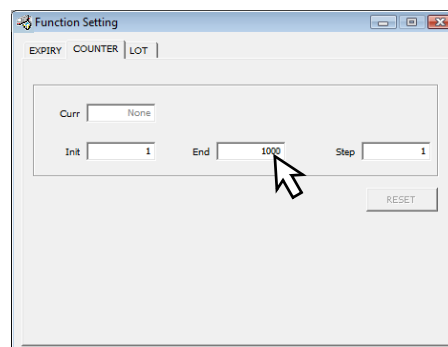

4

Set “1” to [Step].
Input the numeric using the keyboard of the PC.

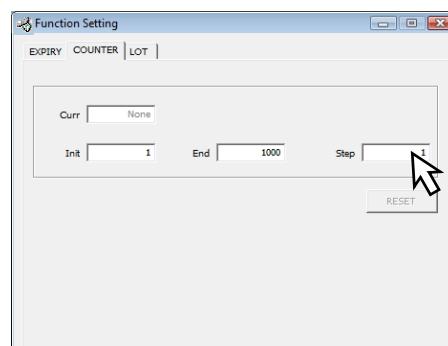

b. Input the counter function character.

Refer to “3-3-3 Input of Function Character” (P.90) for details.

1

Press  Character .

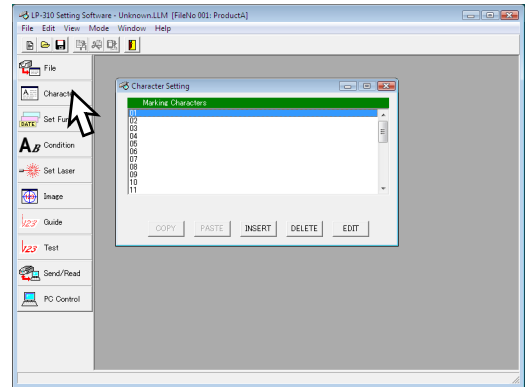

2

Adjust the cursor to the first line (01), and press **EDIT** .

* Re-adjusting the cursor to the first line (01) and then pressing (double-clicking) the same cursor performs the same operation.

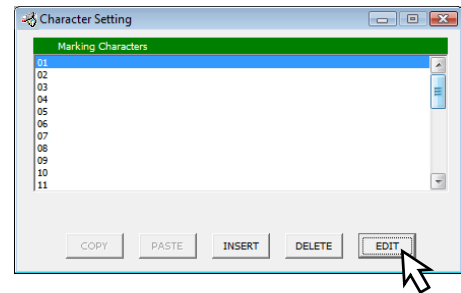

3

Press [COUNTER].

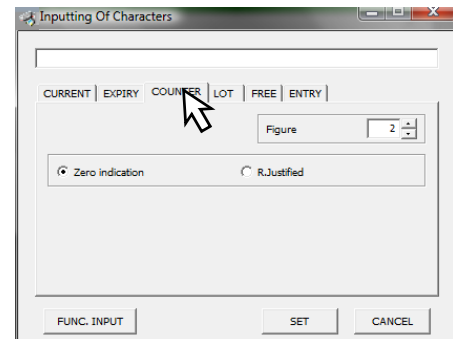

4

Set “4” to the [Figure].
Set the display digit using  button.

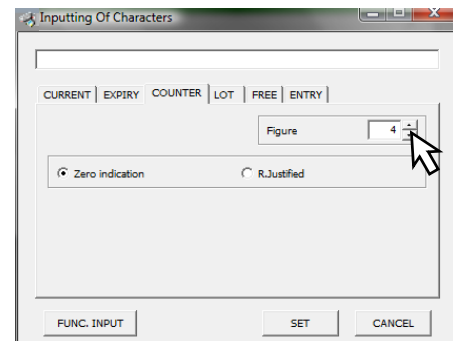

The display digit can be set among 1 to 8.

5

Check [Zero indication].

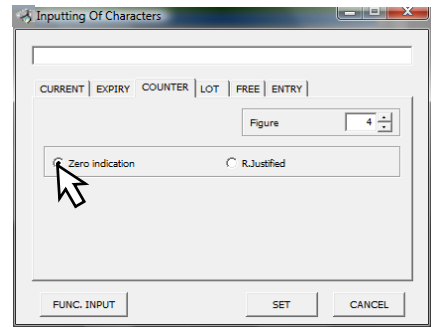

6

Press [FUNC. INPUT], and then press [SET].

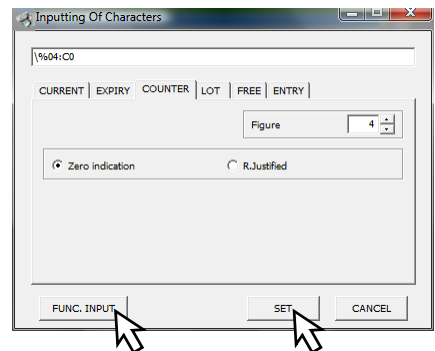

The “\%04:C0” is input in the 01 line of the marking character.

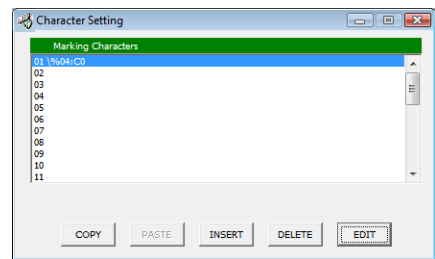

7

Press  Image and check the image.

The “0000” is displayed.

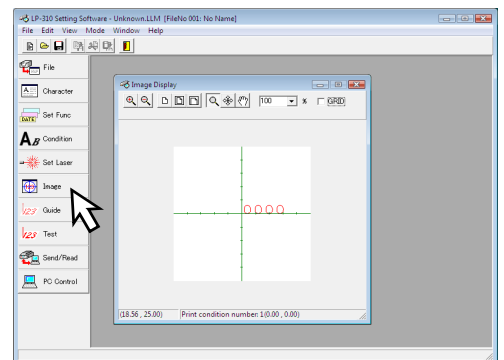

The counter becomes “0000” because the current value of the counter is not impossible to be specified in remote mode. In PC control mode, the current value is displayed in image style.

2-2-2 Mark Lot No.

■ Sample

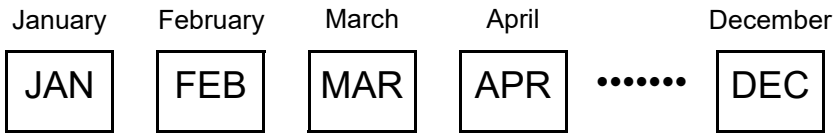

Set the lot No. above.

■ Flow Chart

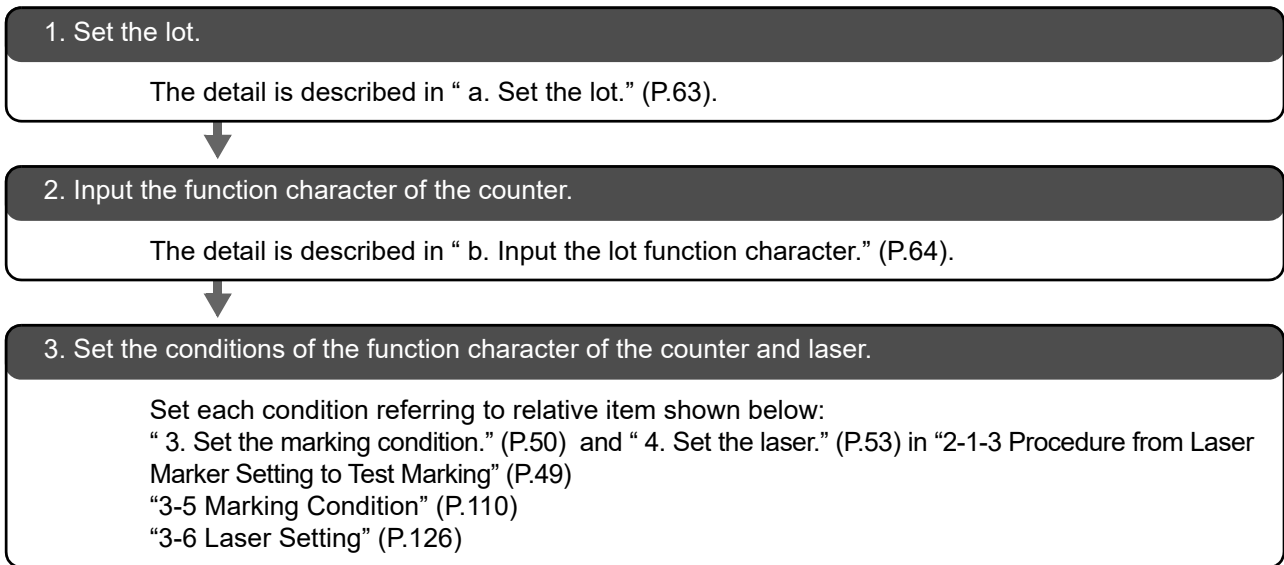

a. Set the lot.

Refer to “3-4-4 Setting of Lot Function” (P.107) for detail setting.

1

Press , and press “LOT”.

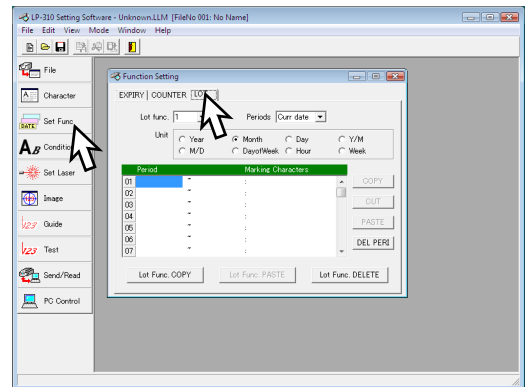

2

Set “1” to [Lot func.]



The lot function is available for setting up to 4 (1 to 4) per file.

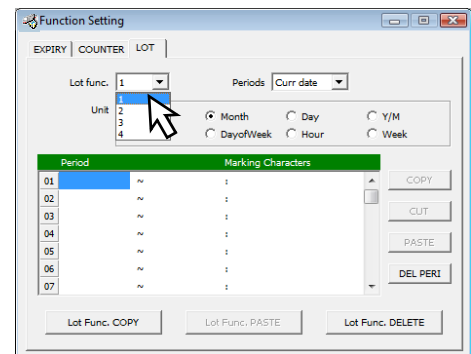

3

Set “Curr date” to [Periods].



Other than [Curr date], it is possible to select [Periods] among [Expiry 1] to [Expiry 4]. Refer to “3-4-4 Setting of Lot Function” (P.107) for details.

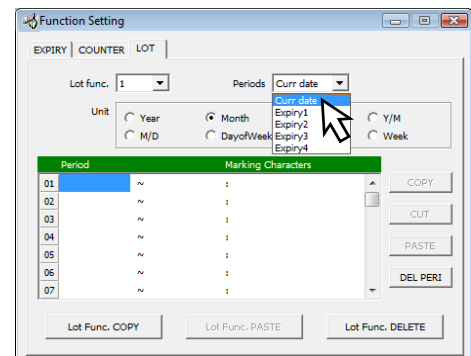

4

Check “Month” to [Unit].

Check “Month” for setting.
The unit is set to “Month” with “Month” state.

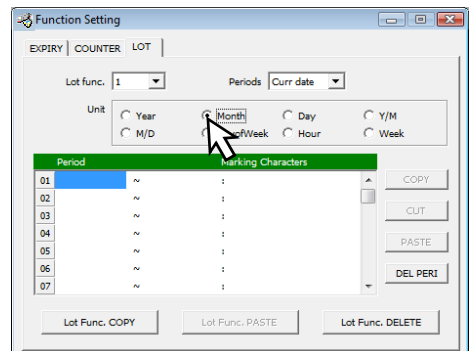

5

Set both [Period] and [Marking Characters].

*In case of operating under Japanese OS, input the double-byte character.

(Set both period and marking character using the keyboard of PC as follows:)

Period	Marking Character String
1 to 1	JAN
2 to 2	FEB
.	.
.	.
.	.
12 to 12	DEC

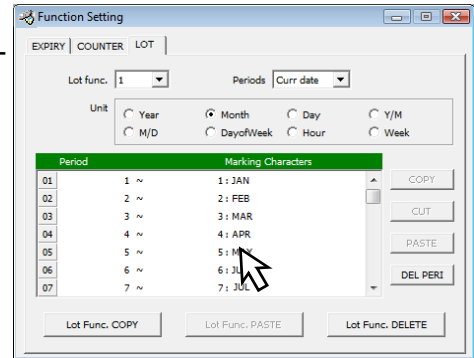

Set the start and end of the duration using “min.” and “max.”. The number of division, setting range, and setting method are differed depending on the selected period condition.

b. Input the lot function character.

Refer to “3-3-3 Input of Function Character” (P.90) for details.

1

Press  Character .

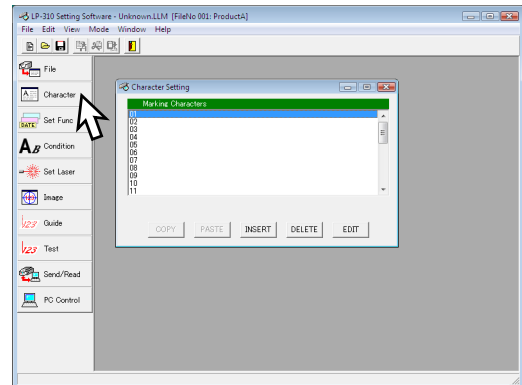

2

Adjust the cursor to the first line “01” of the screen, and press **EDIT** .

* Re-adjusting the cursor to the first line (01) and then pressing (double-clicking) the same cursor performs the same operation.

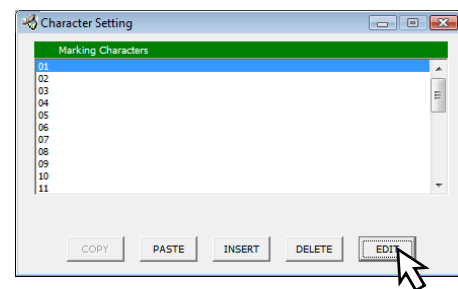

3

Press [LOT].

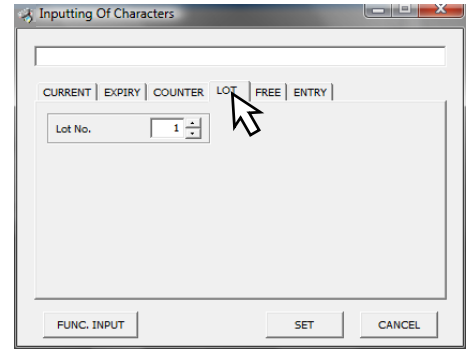

4

Set "1" to [Lot No.].
Set the lot function No. using  button.

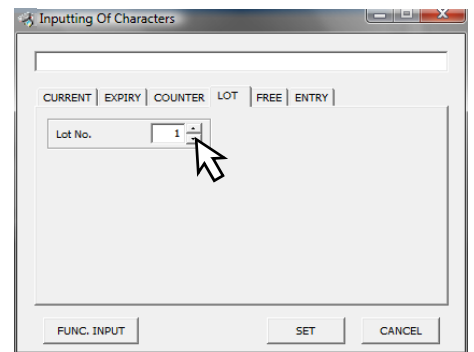

5

Press **FUNC. INPUT**, and then press **SET**.

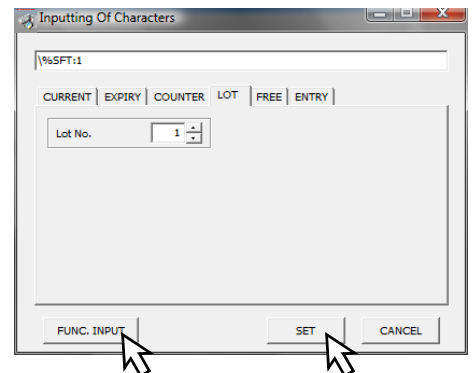

The "%SFT:1" is input in the "01" line of the marking string.

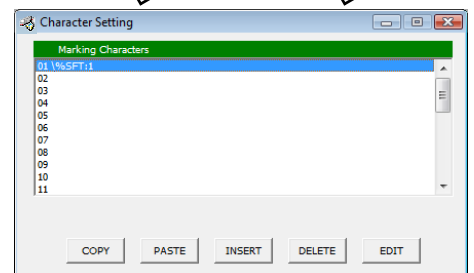

6

Press  Image and check the image.
The image of the target marking character is displayed.

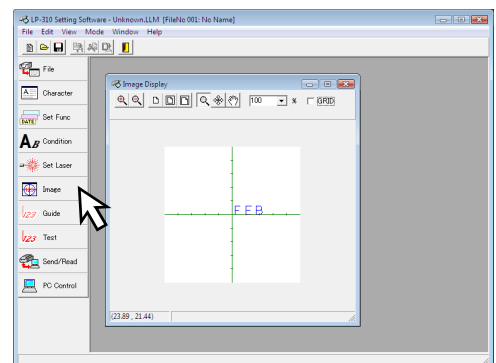

2-2-3 Mark Expiry Date

■ Sample

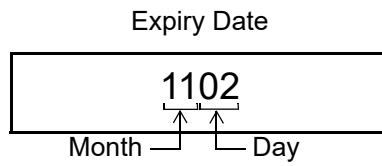

Here the expiry date 30 days after the current date is marked.

■ Flow Chart

1. Set the expiry date.

The detail is described in “ a. Set the expiry date.” (P.67).

2. Input the function character of the expiry date.

The detail is described in “ b. Input the expiry date function character.” (P.68).

3. Set the conditions of the function character of the expiry date and laser.

Set each condition referring to relative item shown below:

“ 3. Set the marking condition.” (P.50) and “ 4. Set the laser.” (P.53) in “2-1-3 Procedure from Laser Marker Setting to Test Marking” (P.49)

“3-5 Marking Condition” (P.110)

“3-6 Laser Setting” (P.126)

a. Set the expiry date.

Refer to “3-4-2 Setting of Expiry Date Function” (P.105) for detail setting.

1

Press  , and press “EXPIRY”.

Here the condition is set to the Expiry 1.



REFERENCE

The expiry is available for setting up to 4 (1 to 4) per file.

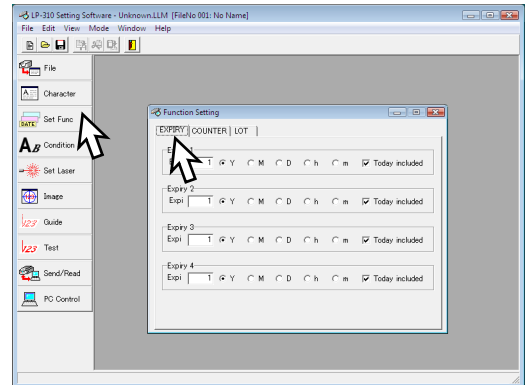

2

Input “30” to the numeric value column of [Expi].
(Input the character using the keyboard of the PC.)

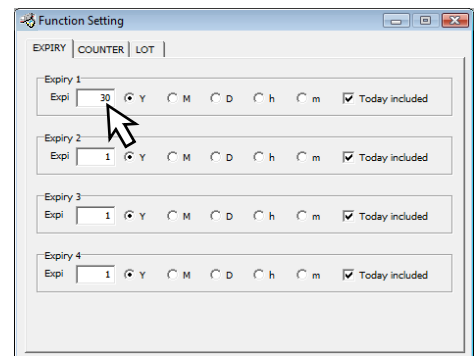

3

Check “D (Day)” to [Expiry 1 (Expiry Condition)].

Check “ D” for setting.

The unit is set to “Day” with “ D”.

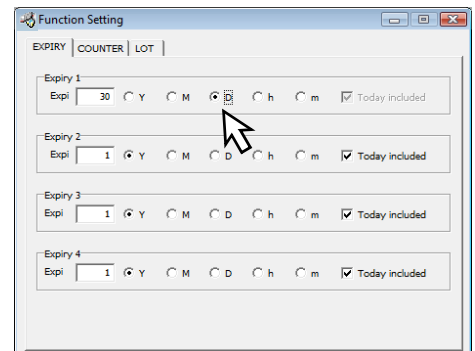

b. Input the expiry date function character.

Refer to “3-4-2 Setting of Expiry Date Function” (P.105) for detail setting.

1

Press  Character .

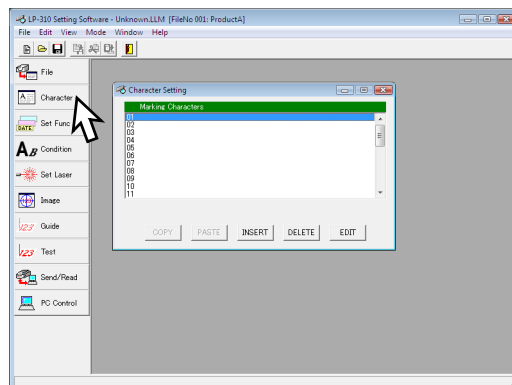

2

Adjust the cursor to the first line “01” on the screen, and press .

* Re-adjusting the cursor to the first line (01) and then pressing (double-clicking) the same cursor performs the same operation.

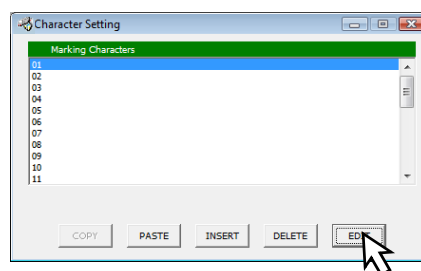

3

Press [EXPIRY].

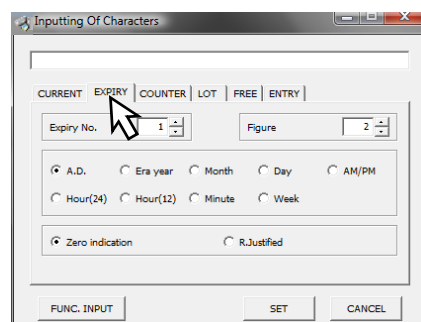

4

Set “1” to [Expiry No.].
Set the expiry No. using  button.

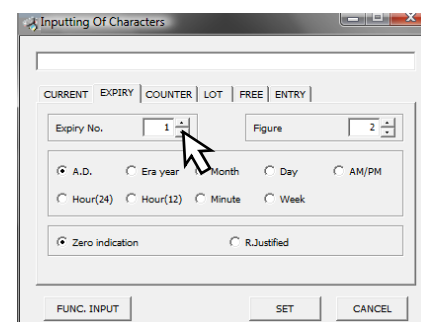

5

Set “2” to [Figure].
Set the display digit using  button.

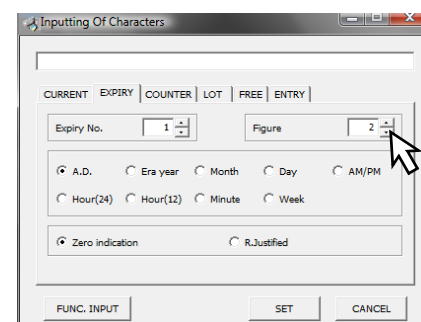

6

Check "Month".

Check "Month" for setting.
The unit is set to "Month" with "Month".

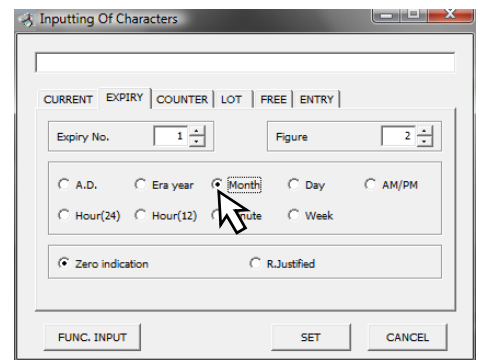

7

Check [Zero indication].

Check "Zero indication" for setting.
The display state is set with "Zero indication".

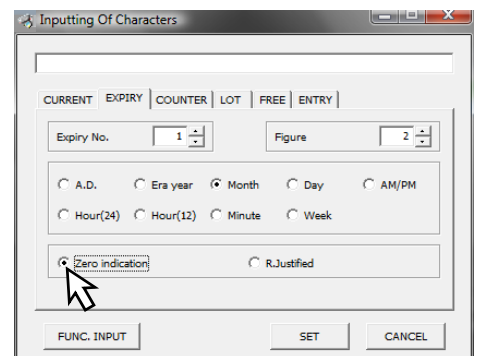

8

Press **FUNC. INPUT**.

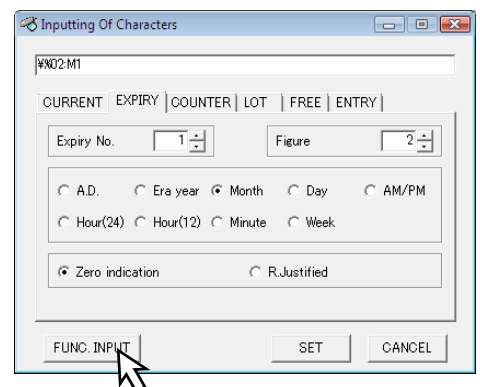

9

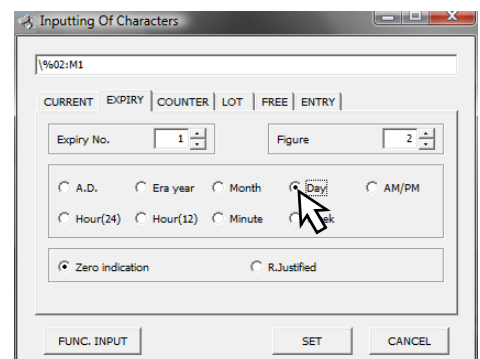

Continuously, check "Day".

Check "Day" for setting.
The unit is set to "Day" with "Day".



10

Check [Zero indication].

Check “ Zero indication” for setting.
The display state is set with “ Zero indication”.

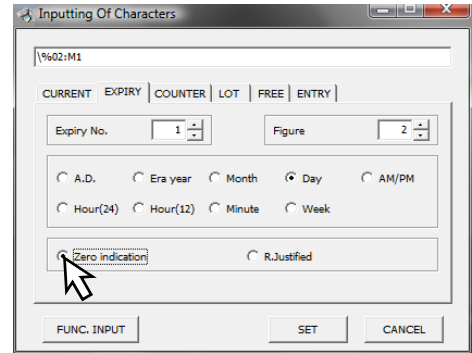

11

Press [FUNC. INPUT], and then press [SET].

The “\%02:M1\%02:D1” is input in the 01 line of the marking string.

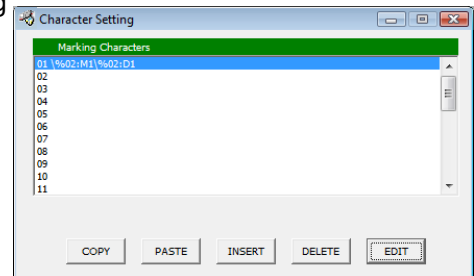
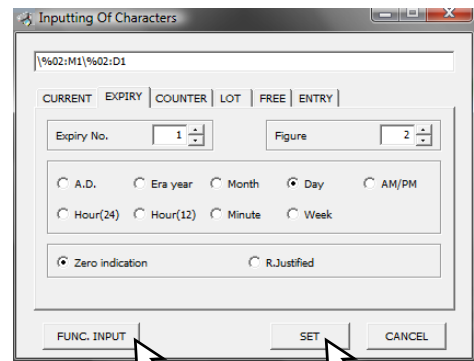

12

Press  Image and check the image.

The image of the target marking character is displayed.

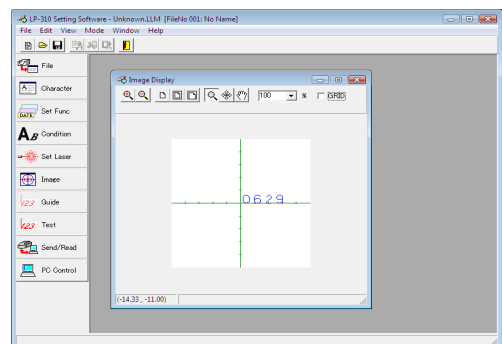

The day after 30days from the current date is displayed.

2-2-4 Mark Current Date

■ Sample

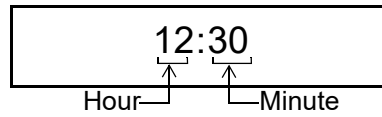

This section describes the procedure for setting the current time.

■ Flow of Procedure

1. Input the function character of the date.

The detail is described in " a. Input date function character." (P.72)



2. Set the conditions of the function character of the date and laser.

Set each condition referring to relative item shown below:
" 3. Set the marking condition." (P.50) and " 4. Set the laser." (P.53) in "2-1-3 Procedure from Laser Marker Setting to Test Marking"
"3-5 Marking Condition" (P.110)
"3-6 Laser Setting" (P.126)

a. Input date function character.

Refer to “3-4-2 Setting of Expiry Date Function” (P.105) for detail setting.

1

Press  Character .

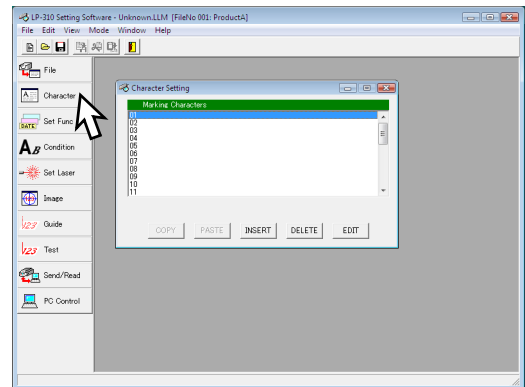

2

Adjust the cursor to the first line “01” of the screen, and press .

* Re-adjusting the cursor to the first line (01) and then pressing (double-clicking) the same cursor performs the same operation.

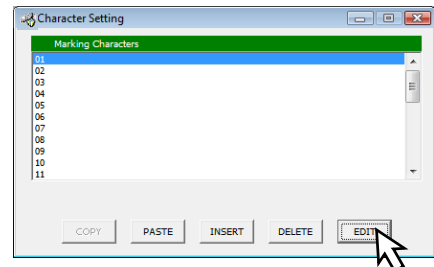

3

Press [CURRENT].

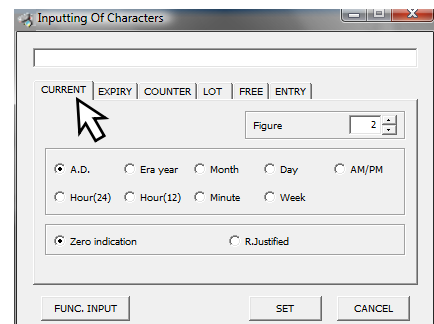

4

Set “2” to [Figure].

Set the display digit using  button.



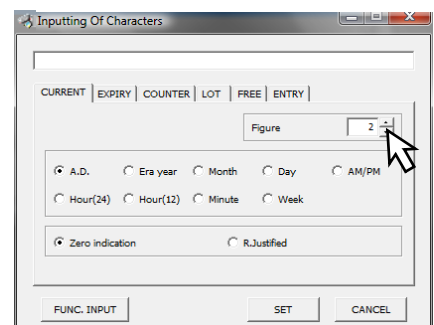

The display digit can be set among 1 to 6.



5

Check [Hour (24)].

Check  Hour (24) for setting.

The unit is set to “Hour” with .

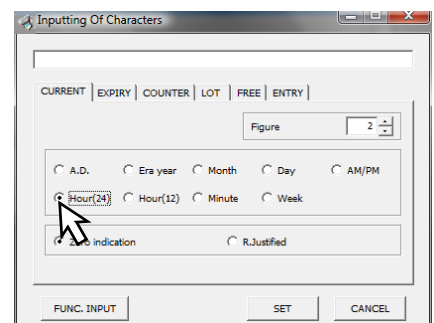

6

Check [Zero indication].

Check “ Zero indication” for setting.
The display state is set with “ Zero indication”.

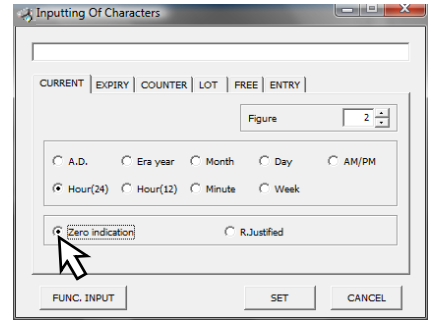

7

Press [FUNC. INPUT].

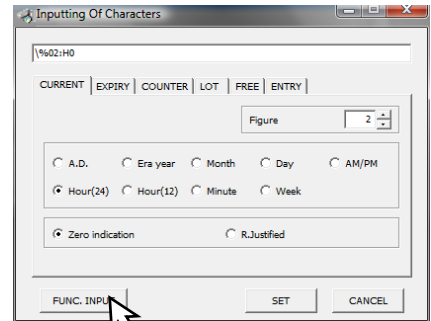

8

Continuously, set “2” to [Figure].
Set the display digit using button.



The display digit can be set among 1 to 6.

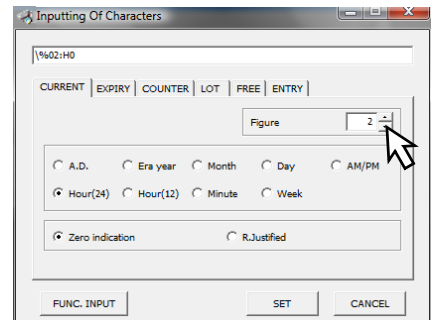

9

Check [Minute].

Check “ Minute” for setting.
The unit is set to “Minute” with “ Minute”.

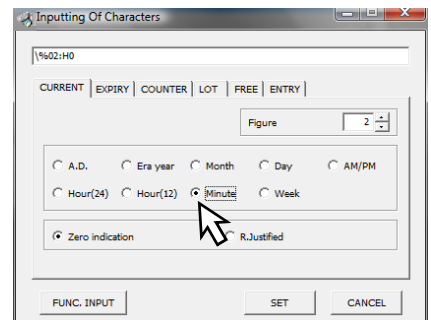

10

Check [Zero indication].

Check “ Zero indication” for setting.
The display state is set with “ Zero indication”.

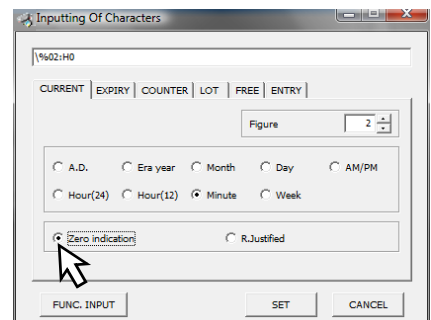

11

Press **FUNC. INPUT**, and then press **SET** .

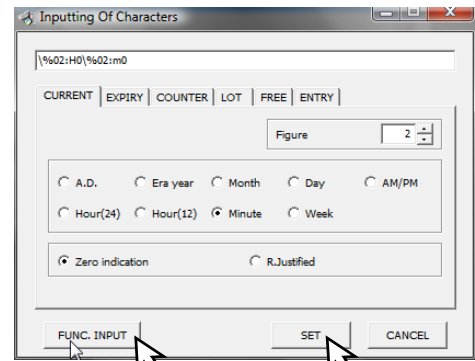

The “\%02:H0\%02:m0” is input in the 01 line of the marking string.

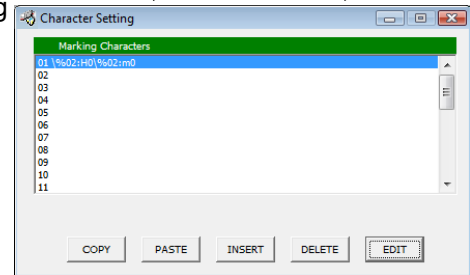

12

Press **Image** and check the image.

The image of the target marking character is displayed.

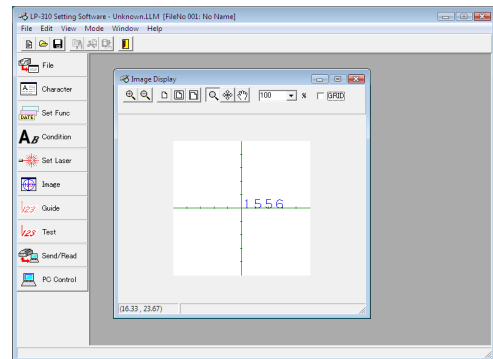

The current time (Hour/Minute) is set.

3 Description of Operation Screen

3-1 Description of Main Screen	76
3-2 File Selection	82
3-3 Character Setting	88
3-4 Function Setting	104
3-5 Marking Condition	110
3-6 Laser Setting	126
3-7 Image Display.....	130
3-8 Guide Indication	134
3-9 Test Marking.....	138
3-10 Send/Read	140
3-11 PC Control/Remote Mode	144
3-12 Switching Language between Japanese and English	147
3-13 Error History	148
3-14 Environmental Setting	150



3-1 Description of Main Screen

3-1-1 Main Screen

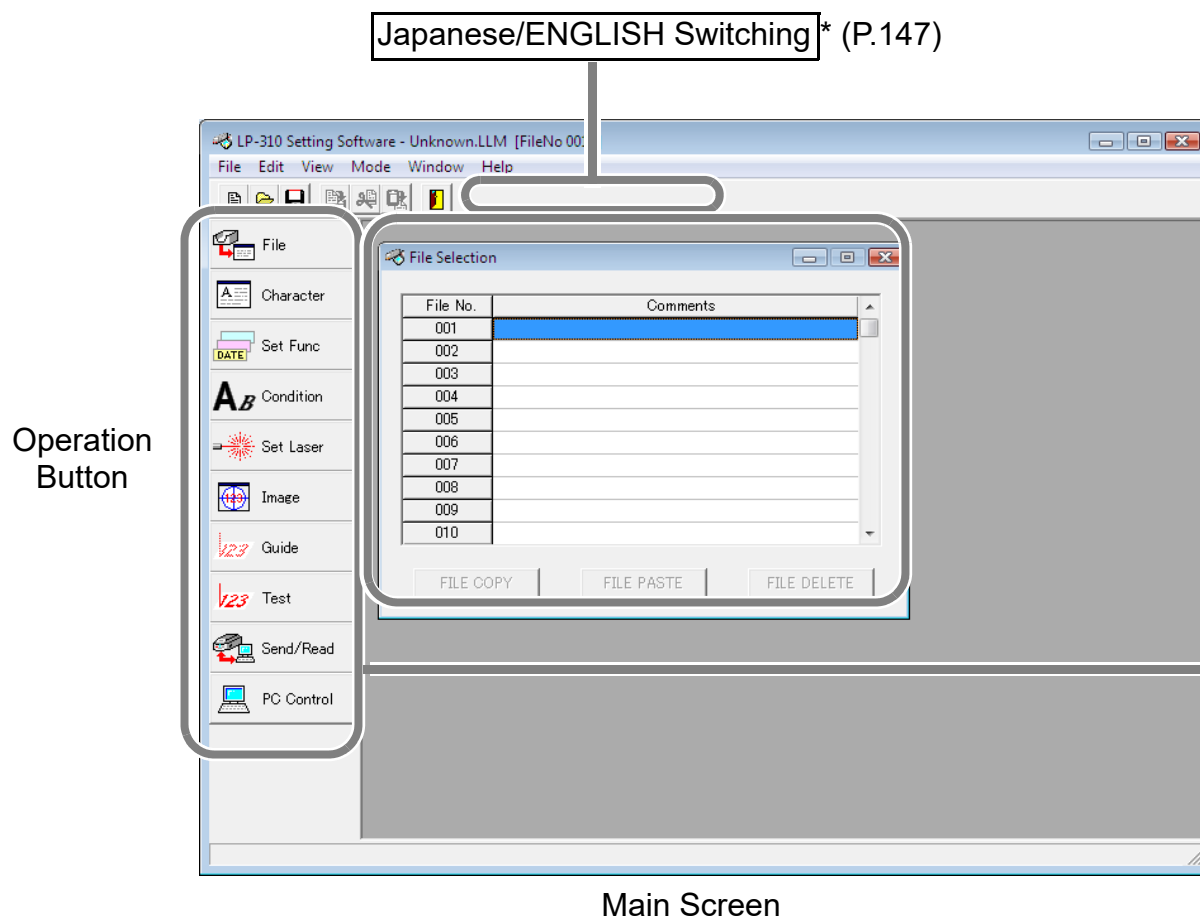
When this setting software is started up, the following screen is displayed.
This screen is called "Main Screen".

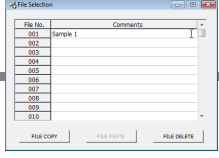
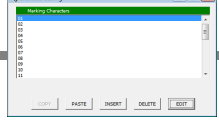
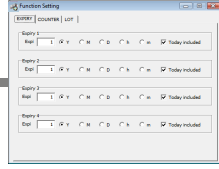
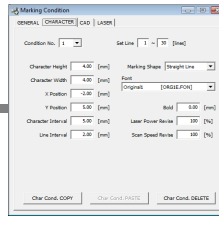

- * The "Language" is displayed when the LP-310 setting software is installed into the PC installed Windows Japanese OS.
(When the LP-310 setting software is installed into the PC installed Windows English OS, the "Language" is not displayed.)

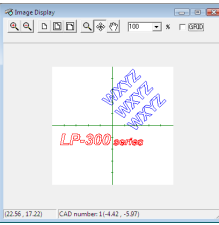
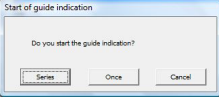
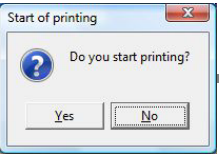
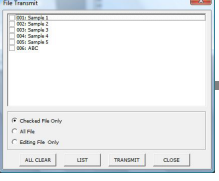
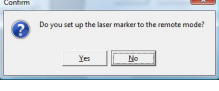
File Selection (P.82)		<ul style="list-style-type: none"> • Marking File P.82 • New Creation P.83 • Open P.84 • Save P.85 • Save As P.85 • Registration File and Marking File P.86
Character Setting (P.88)		<ul style="list-style-type: none"> • Character Setting Screen P.88 • Input of Marking Character P.89 • Input of Function Character P.90
Function Setting (P.104)		<ul style="list-style-type: none"> • Function Setting Screen P.104 • Setting of Expiry Date Function P.105 • Setting of Counter Function P.106 • Setting of Lot Function P.107
Marking Condition (P.110)		<ul style="list-style-type: none"> • Setting Screen of Marking Condition P.110 • General Conditions P.111 • Character Condition P.115 • CAD Condition P.120 • Laser Check P.124
Laser Setting (P.126)		<ul style="list-style-type: none"> • Screen for Laser Setting P.126 • Line Width P.127 • Marking Pitch P.127 • Adjustment of Laser Start/End Points P.128 • Adjustment of Marking Quality P.129
Image Display (P.130)		<ul style="list-style-type: none"> • Image Display Screen P.130 • Magnification Method P.131 • Adjustment of Marking Position P.132 • Adjustment of Display Position P.133
Guide Indication (P.134)		<ul style="list-style-type: none"> • Center Position Indication P.134 • Guide Indication P.134 • Cautions P.136
Test Marking (P.138)		<ul style="list-style-type: none"> • Test Marking P.138
Send/Read (P.140)		<ul style="list-style-type: none"> • File Transmit P.140 • File List P.142 • Backup P.142 • Restore P.143
PC Control/Remote Mode (P.144)		<ul style="list-style-type: none"> • Remote Mode P.144 • PC Control Mode P.146



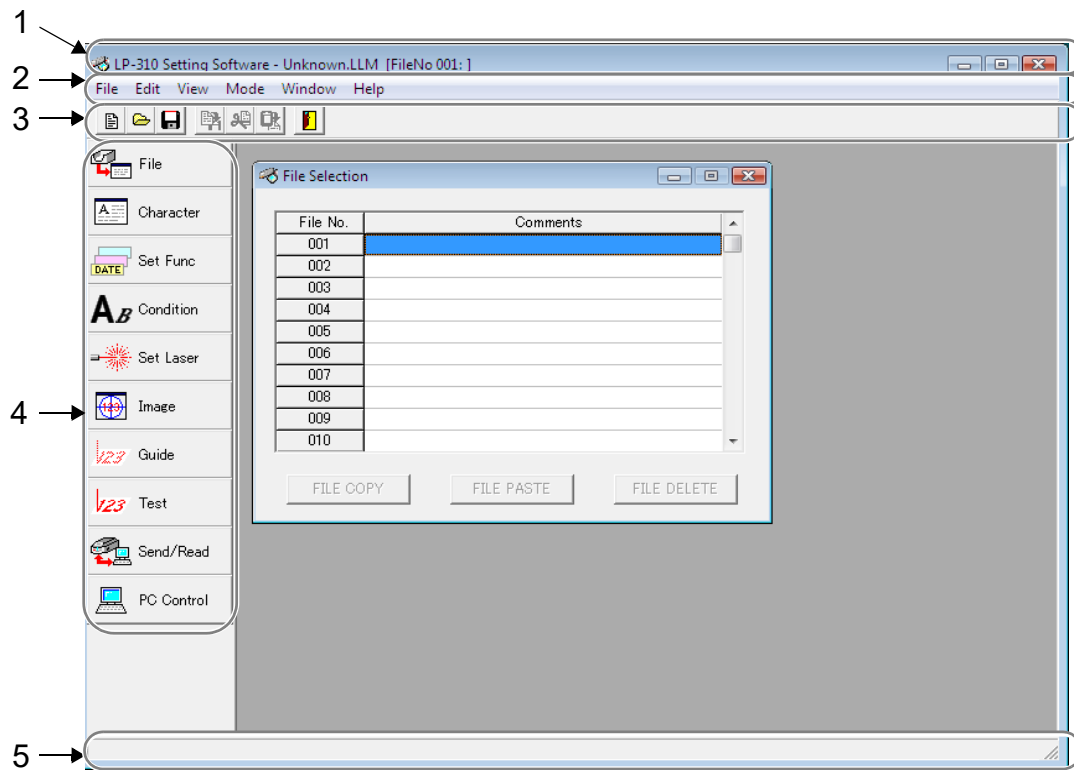



3-1-2 Construction of Main Screen



- 1 Title Bar : Displays the application name, registration name, and file No. of marking file.
- 2 Menu Bar : Displays basic menu.
Refer to “3-1-3 Menu Function” (P.79) for details.
- 3 Tool Bar : The edit functions of the file are minimized.
Refer to “3-1-4 Tool Button Function” (P.81) for details.
- 4 Operation Button : Displays the function buttons used very often.
- 5 Display Area : Displays the selected operation content and setting range.

3-1-3 Menu Function







■ File

Item	Description
New File	Creates a new registration file. Clicking  button performs the same function. (P.83)
Open	Reads the existing registration file. Clicking  button performs the same function. (P.84)
Save	Saves the registration file under editing. Clicking  button performs the same function. (P.85)
Save As	Saves the registration file under editing as a name. (P.85)
GUIDE	Traces (guides) the center position of the current processing work and current marking character string with a red laser. The guide indication is performed in PC control mode. Clicking  performs the same function. (P.134)
TEST	Performs the test marking from PC in PC control mode. Clicking  performs the same function. (P.138)
SEND/READ	Performs the processing related to the send/read of the marking file. Clicking  performs the same function. (P.140)
ERROR	Displays the date and content of the error occurred in the past. (P.148)
ENVIRONMENT	Sets the environment of the laser marker and PC. (P.150)
Exit	Selects this function when finishing this software.

■ Edit

Item	Description
Cut	Cuts the selected line.
Copy	Copies the selected line.
Paste	Pastes the selected line just after copied

■ View

Item	Description
File	Displays the file setting form. Clicking  performs the same function. (P.82)
Character	Displays the character setting form. Clicking  performs the same function. (P.88)
Set Func	Displays the function setting form. Clicking  performs the same function. (P.104)
Condition	Displays the marking condition setting form. Clicking  performs the same function. (P.110)
Set Laser	Displays the laser setting function. Clicking  performs the same function. (P.126)
Image	Displays the marking image. Clicking  performs the same function. (P.130)

■ Mode

Item	Description
PC Control/Remote	Switches mode between “Remote Mode” and “PC Control Mode”. Clicking  and  performs the same function. (P.144)

■ Window

Item	Description
Cascade	Displays the opening windows in cascade status.
Tile	Displays the opening windows in tile status.
Arrange	Arranges the shifted icons at lower side.
Minimize	Minimizes all the displaying windows.

■ Help

Item	Description
Manual	Displays the operation manual.
About... (Version Information)	Selects this item when checking the version information of this software. Clicking [OK] button closes this window.

3-1-4 Tool Button Function



“New creation” button

Click this button for creating a new registration file.

If the existing file is under editing without saved, the check dialog box “LP-310 Setting Software” whether the current file requires saving or not is appeared.



“Open the file” button

Click this button for reading the existing registration file.

“Open the file” dialog box is appeared.

The selectable files of type are as follows:

- File with its extension “.LLM” (Registration file)
- File with its extension “.LLB” (Backup file)



“Save” button

Click this button for saving (overwriting) the registration file under editing.

When saving (overwriting) the new-created registration file (with its file name is not registered) after editing, the dialog box for setting file name is appeared.



“Copy” button

Click this button for copying the selected line.



“Cut” button

Click this button for cutting the selected line.



“Paste” button

Click this button for pasting the selected line just after copied.



“Exit” button

Click this button for exiting this software.

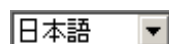

“Language Selection” button

This software can select the display language from either “Japanese” or “English” by pulling down this button.

* The “Language” is displayed when the LP-310 setting software is installed into the PC installed Windows Japanese OS. (When the LP-310 setting software is installed into the PC installed Windows English OS, the “Language” is not displayed.)

3-2 File Selection

3-2-1 Marking File

This function selects the marking file to be edited/set.

1 View - "File"

2 Click  File .

The "File Selection" screen for selecting marking file is appeared by clicking either selecting "1" method or clicking "2" button described above.

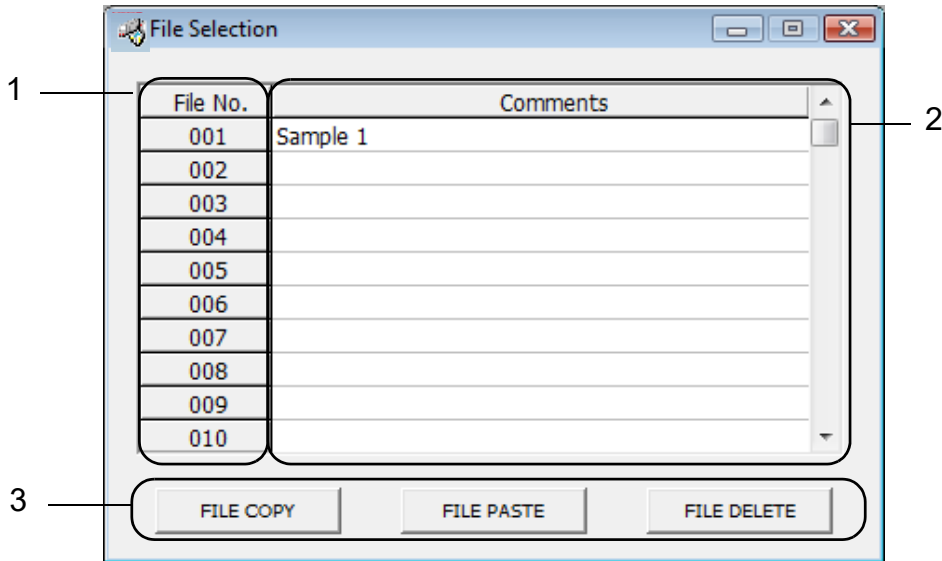

Item	Description
1. File No.	Total 120 marking files are available for setting.
2. Comments	The marking file name can be added to each file No. (This file name differs from the registration file name.)
3. FILE COPY/ FILE PASTE/ FILE DELETE	All the contents of the marking file are available for copy/paste/delete. This function is useful for setting the similar operation.



REFERENCE

The image can be displayed by double-clicking the selected marking file.

3-2-2 Registration File

The registration file displays the parent file to be saved into PC. This parent file has 120 data files (see “3-2-1 Marking File” (P.82), and each data file can be managed respectively.

■ New Creation

With this operation, a new registration file is created.

1 “File” - “New File”

2 Click  .

A new registration file can be created by either selecting “1” or clicking “2” icon described above.

If the existing file is under editing without saved, the check dialog box “LP-310 Setting Software” whether the current file requires saving or not is appeared.

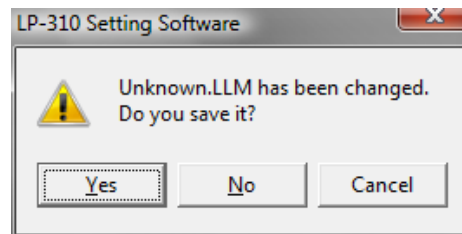

Item	Description
Yes	Saves (overwrites) the registration file under editing, and then creates a new registration file.
No	Deletes all registration files under editing, and then creates a new registration file.
Cancel	Closes the dialog box, and returns to the previous screen.

■ Open

With this operation, the existing registration file is read.

1 “File” - “Open”

2 Click  .

The dialog box for opening the registration file is appeared by either selecting “1” method or clicking “2” icon described above.

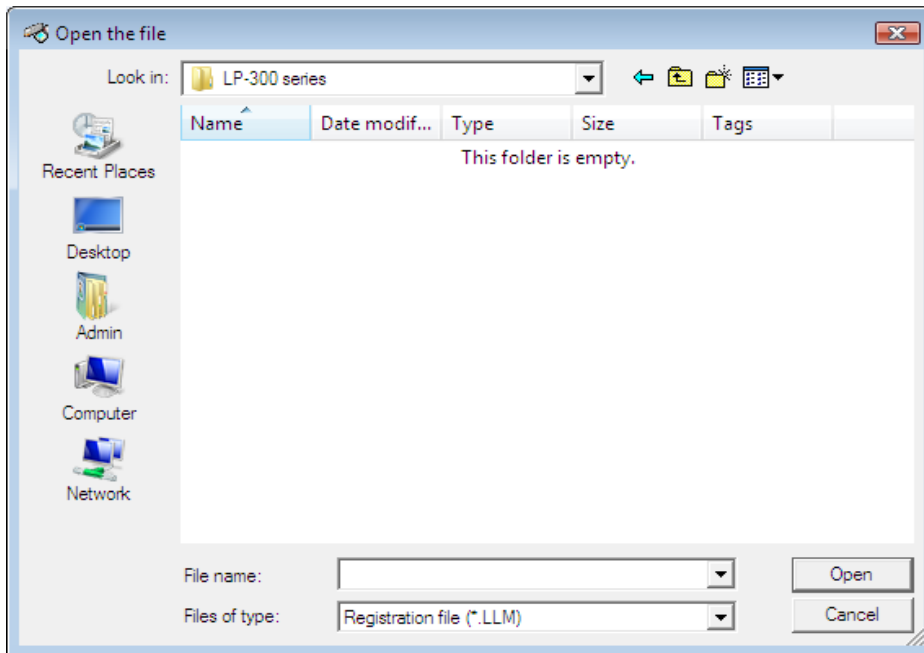

File name : Sets the file name of the registration file to be read.

Files of type : Enables to read either the registration file with “.LLM” extension or backup file with “.LLB” extension.

Select the registration file to be read, and click “Open” icon for reading the registration file.

Clicking “Cancel” closes the dialog box and returns to the previous screen.



The warning might be appeared depending on the content of the read file, and also might be required to read that file after correcting.

In this case, since the content of the read file has not been changed unless overwriting that file, do not execute the saving (overwriting) of the file.

The warning is appeared when the non-specified font file is used for the marking file read.

■ Save

With this operation, the registration under editing is saved (overwritten).

1 “File” - “Save”

2 Click  icon.

The registration file under editing is saved (overwritten) by either selecting “1” method or clicking “2” icon described above.

When saving a new created registration file (with its name not registered) after editing, the dialog box for setting file name is appeared.



REFERENCE

Refer to the next procedure “Save As” for details.

■ Save As

With this operation, the registration file under editing is saved as the registration file with other file name user named.

Selecting “File” - “Save As” appears the dialog box for setting file name.

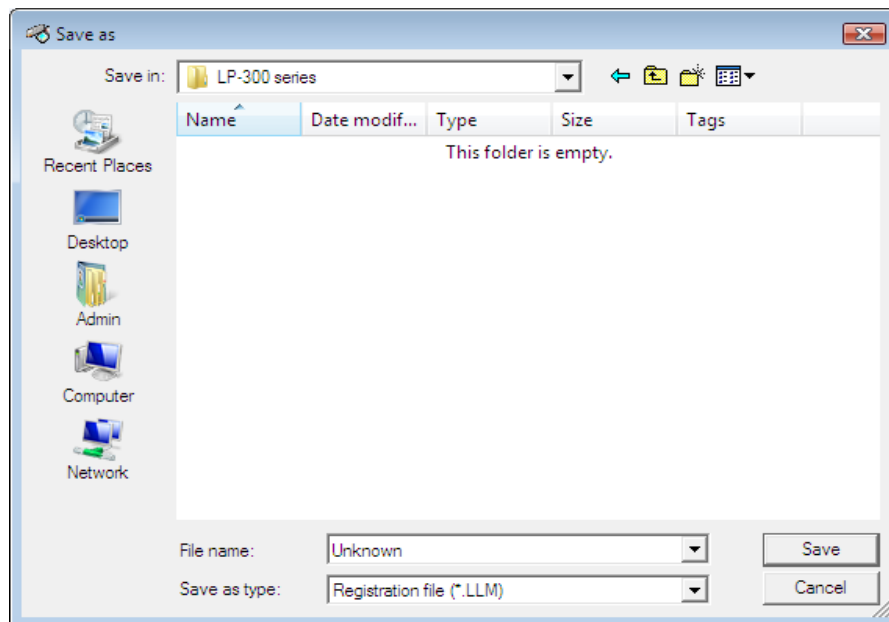

File name : Sets the registration file name for saving.

Save as type : Enables to save only the registration with “.LLM” extension.

The registration file under editing is saved by setting the file name and then clicking “Save”. Clicking “Cancel” closes the dialog box and returns to the previous screen.

3-2-3 Registration File and Marking File

- Registration file : Parent file to be saved in PC. This file can set 120 sub files (marking files) into it (extension: ".LLM")
- Marking file : Independent sub file to be used for marking.

Create one registration file for each laser marker.
Sample of registration file name: "Product Line A.LLM"

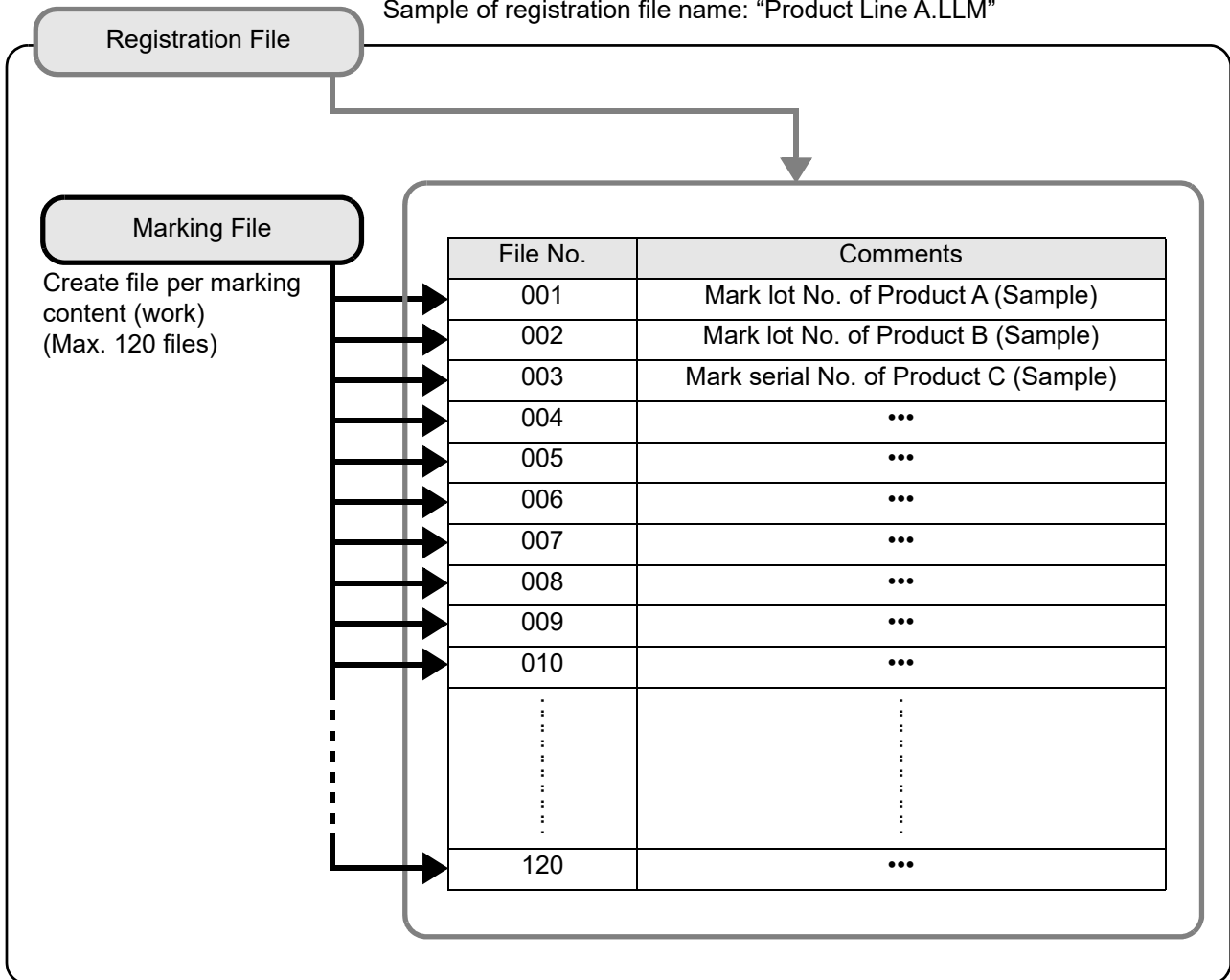

MEMO

3-3 Character Setting

3-3-1 Character Setting Screen

The character to be marked is set by inputting from “Character Setting” screen.

1 “View” - “Character”

2 Click  Character .

The “Character Setting” dialog box is appeared by either selecting “1” method or clicking “2” button described above.

The marking character has 30 lines, and max. 30 letters per line are available for input.

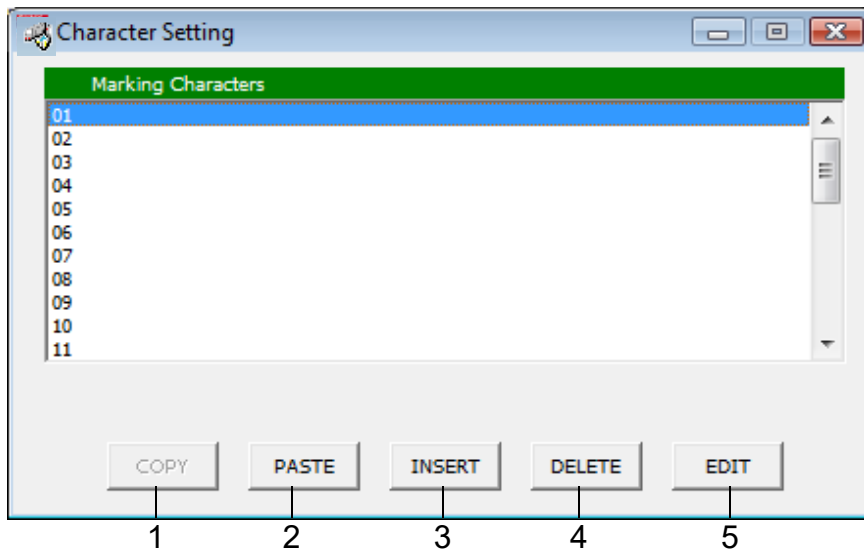

The buttons in the “Character Setting” dialog box are used for editing character string by line.

Item	Description
1. COPY	Copies the selected line.
2. PASTE	Pastes the selected line just copied.
3. INSERT	Inserts one line just before selected line. Note that if inserting one line just on the 30th line, the character string in the existing 30th line is deleted.
4. DELETE	Deletes the selected line.
5. EDIT	Edits the selected line. The dialog box for inputting the marking character string is appeared.



REFERENCE

It is useful for setting the character checking the image on the image display. Refer to “3-7 Image Display” (P.130) for details.

The following warning is appeared after copying the line including the optional character string. If this warning is appeared, the paste is invalid. Refer to “3-3-3 Input of Function Character” - “(5) Input optional character string” (P.100) for details.

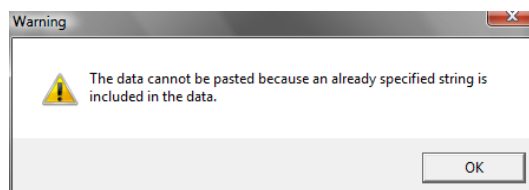

3-3-2 Input of Marking Character

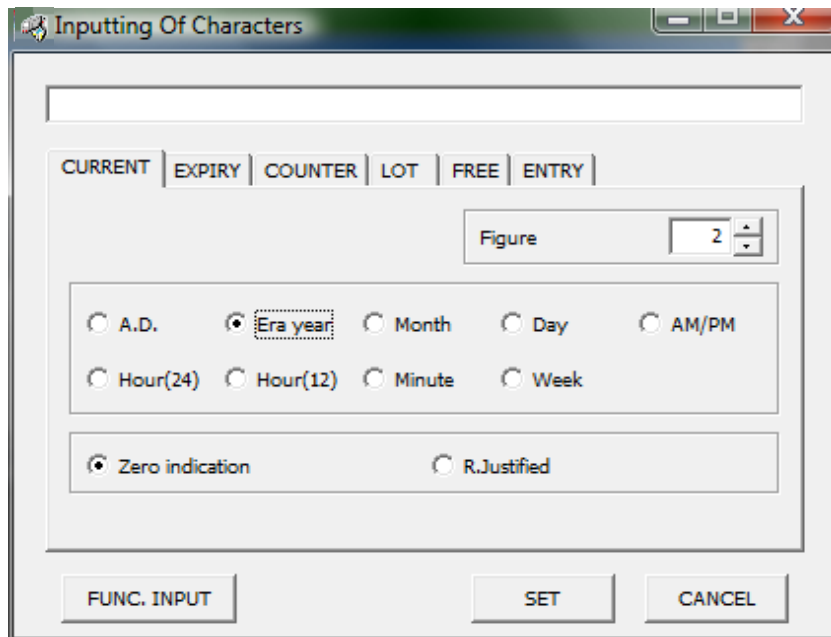

■ Setting Flow

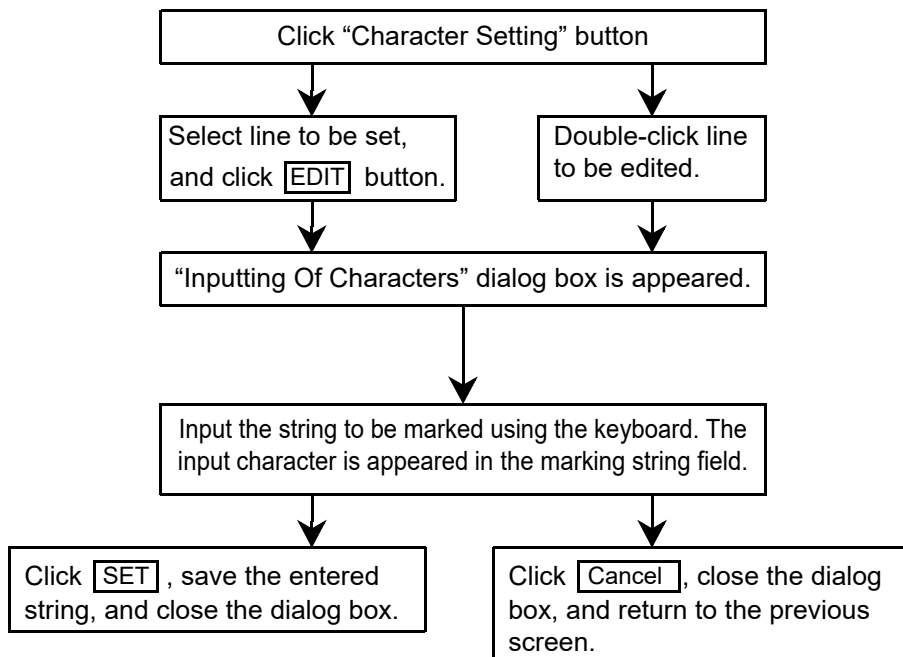

REFERENCE

Input the character in double-byte character for Japanese OS and in single-byte character for English OS. Refer to "Character Code Table" (P.198) for details of the available characters for input.

3-3-3 Input of Function Character

The "Inputting Of Character" screen can also be input the function character other than normal character.

(1) Input current date

Outline : Function for marking date and time of the internal clock in the main body of the laser marker.

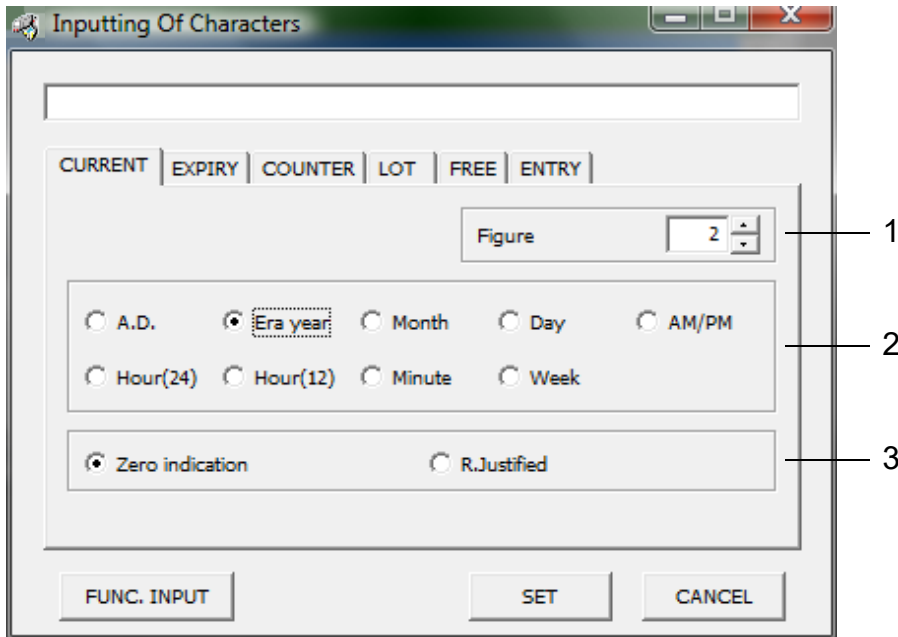

1 Figure : Sets the figure with button. The setting range for the figure is selectable among 1 to 6.

2 Display Content : Enables to select either item by checking the corresponding radio button.

Radio Button	Description
A.D.	Sets the dominical year.
Era year	Sets the era year.
Month	Sets the month.
Day	Sets the day.
AM/PM	Sets either morning or afternoon.
Hour (24)	Sets the 24-hour time.
Hour (12)	Sets the 12-hour time.
Minute	Sets the minute.
Week	Sets the week.

3 Zero indication : Enables to select either item by checking the corresponding radio button.

Radio Button	Description
Zero indication	Marks value in right-justified, and mark "0" to the left.
R.Justified	Marks value in right-justified, and blanks left column.



REFERENCE

- The setting date is displayed as setting on PC on the image display.

■ Setting Flow

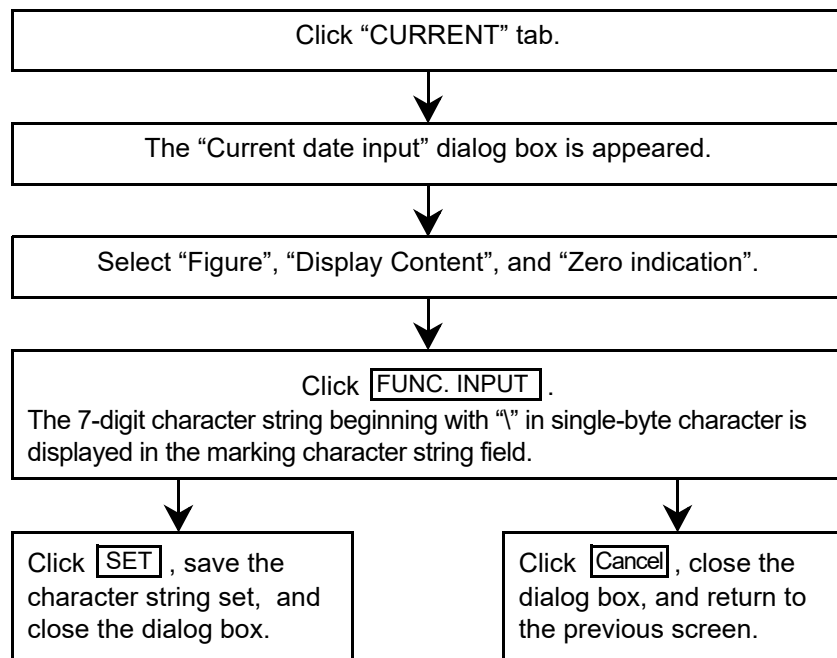

(Display Sample)

\ % 0 1 : Y 0
 ↓ ↓ ↓ ↓ ↓
 1 2 3 4 5

	Display	Description
1	%	Indicates the functional character string.
2	0	Sets zero indication.
	␣	Set the R.justified. (single-byte space)
3	*	The display digit from 1 to 6 is displayed in the “*”.
4	Y	Sets the dominical year.
	y	Sets the era year.
	M	Sets the month.
	D	Sets the day.
	H	Sets the 24-hour time.
	h	Sets the 12-hour time.
	m	Sets the minute.
	w	Sets the week.
5	0	Sets the current date with zero fixed.

In case of selecting “AM/PM”, the figure and zero indication are ignored, and the display is shown as follows.

\ % A P M : 0

(2) Input expiry date

Outline : Function for marking expiry date adding the value input at function setting to the date and time of the internal clock in the main body of the laser marker.

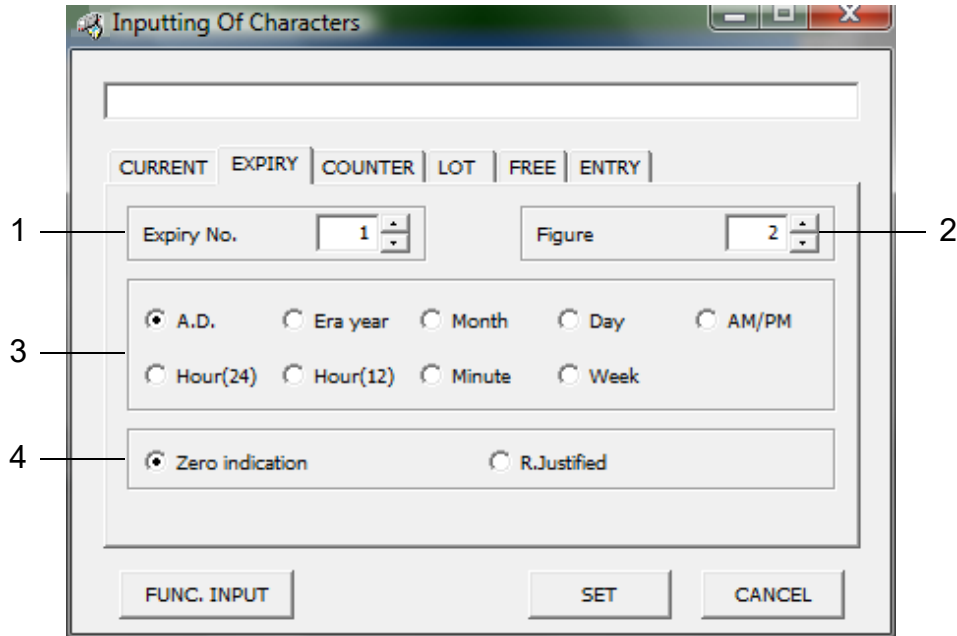

- 1 Expiry No. : Sets the expiry No. with button. The setting range is selectable among 1 to 4.
- 2 Figure : Sets the figure with button. The setting range is selectable among 1 to 6.
- 3 Display Content : Enables to select either item by checking the corresponding radio button.

Radio Button	Description
A.D.	Sets the dominical year
Era year	Sets the era year
Month	Sets the month
Day	Sets the day
AM/PM	Sets AM/PM
Hour (24)	Sets the 24-hour time.
Hour (12)	Sets the 12-hour time.
Minute	Sets the minute
Week	Sets the week

- 4 Zero indication : Enables to select either item by checking the corresponding radio button.

Radio Button	Description
Zero indication	Marks value in right-justified, and mark "0" to the left.
R.Justified	Marks value in right-justified, and blanks left column.



- The setting date is displayed on the image display as setting on PC.
- The expiry date is referred to the date adding the expiry to the current date. The expiry is available to memorize 4 patterns with the expiry No. 1 to 4. Refer to "Setting of Expiry Date Function" (P.105) for details.

■ Setting Flow

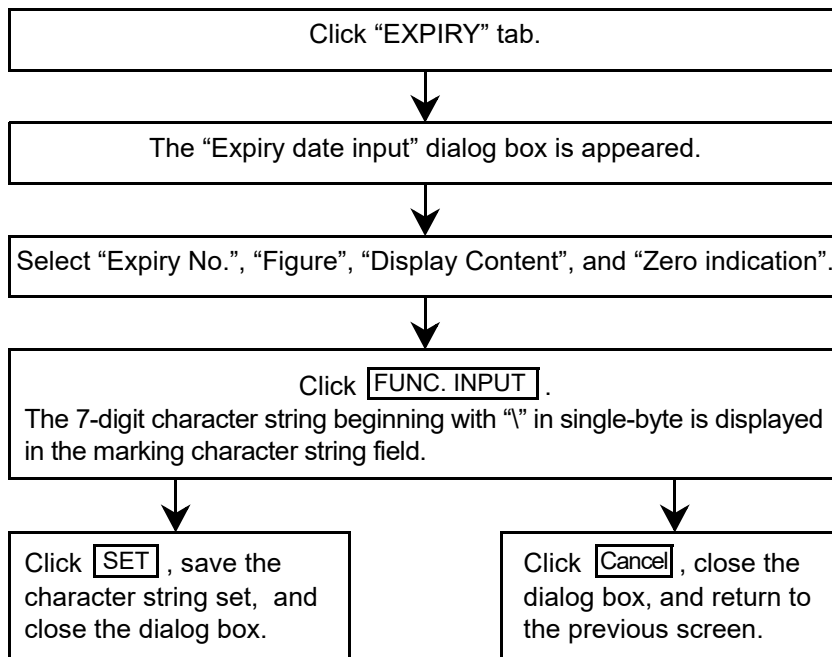

(Display Sample)

\ % 0 1 : Y 1
 ↓ ↓ ↓ ↓ ↓
 1 2 3 4 5

	Display	Description
1	%	Indicates the functional character string.
2	0	Sets zero indication.
	┘	Set the R.justified. (single-byte space)
3	*	The display digit from 1 to 6 is displayed in the “**”.
4	Y	Sets the dominical year.
	y	Sets the era year.
	M	Sets the month.
	D	Sets the day.
	H	Sets the timer in 24 hours.
	h	Sets the timer in 12 hours.
	m	Sets the minute.
5	w	Sets the week.
	*	“**” is varied in accordance with the lot function No. (1 to 4).

In case of selecting “AM/PM”, the figure and zero indication are ignored, and the display is shown as follows.

\ % A P M : 1

(3) Input counter

Outline : Function for increasing the value every marking

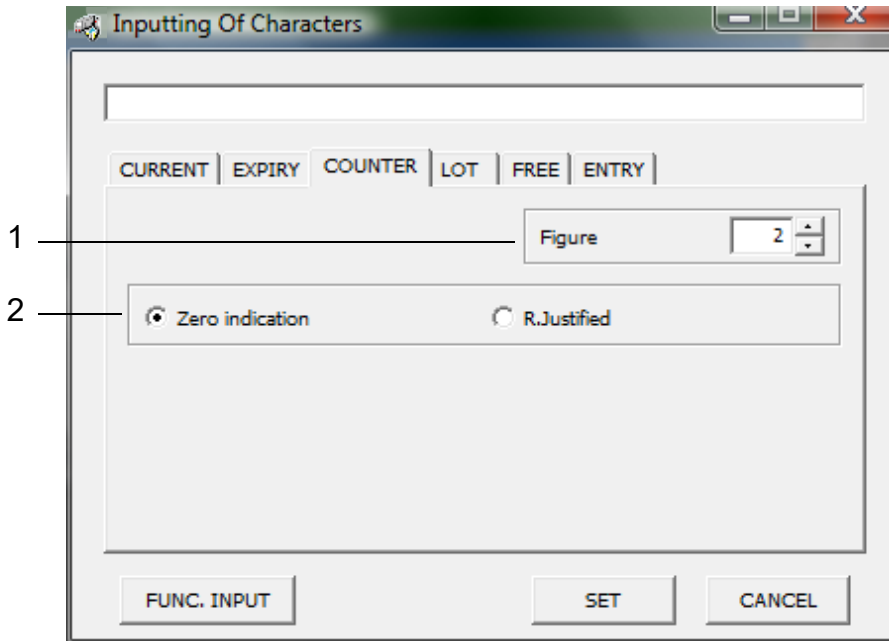

- 1 Figure : Sets the figure with button. The setting range is selectable among 1 to 8.
- 2 Zero indication : Either item can be selected by checking the corresponding radio button.

Radio Button	Description
Zero indication	Marks value in right-justified, and mark "0" to the left.
R.Justified	Marks value in right-justified, and blanks left column.

■ Setting Flow

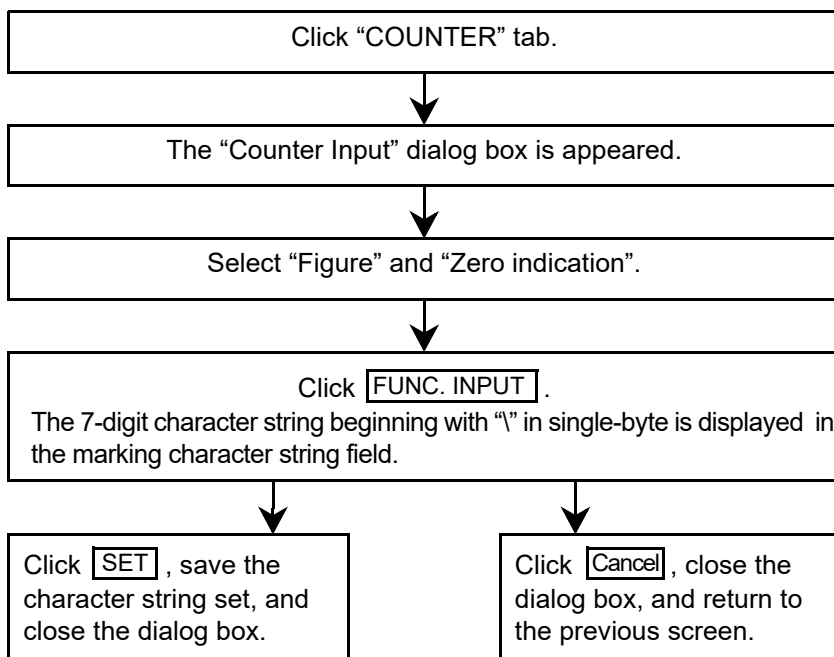

(Display Sample)

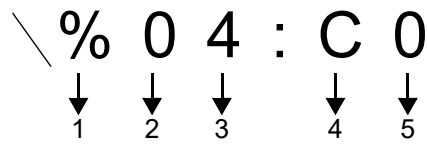

	Display	Description
1	%	Indicates the functional character string.
2	0	Sets zero indication.
	┐	Set the R.justified. (single-byte space)
3	*	The display digit from 1 to 8 is displayed in the “*”.
4	C	Indicates the function character of the counter.
5	0	Sets the counter with zero fixed.



REFERENCE

The counter function is the function increasing the value from the initial value to final value every step.
 Refer to “3-4-3 Setting of Counter Function” (P.106) for details.



CHECK

- The processing of the final value is repeated. The counter ending is output at final value, and the value is cleared at the next trigger, and the marking is started from the initial value.
- In case of marking from the initial value again, set the current value at “0” or perform the marking after transferring. In case of performing marking in remote mode, reset the counter for marking from the initial value.



CHECK

- The value is not counted-up at test marking and guide indication.

(4) Input lot

Outline : Function for marking duration and character string input at function setting in accordance with the internal clock in the main body of the laser marker.

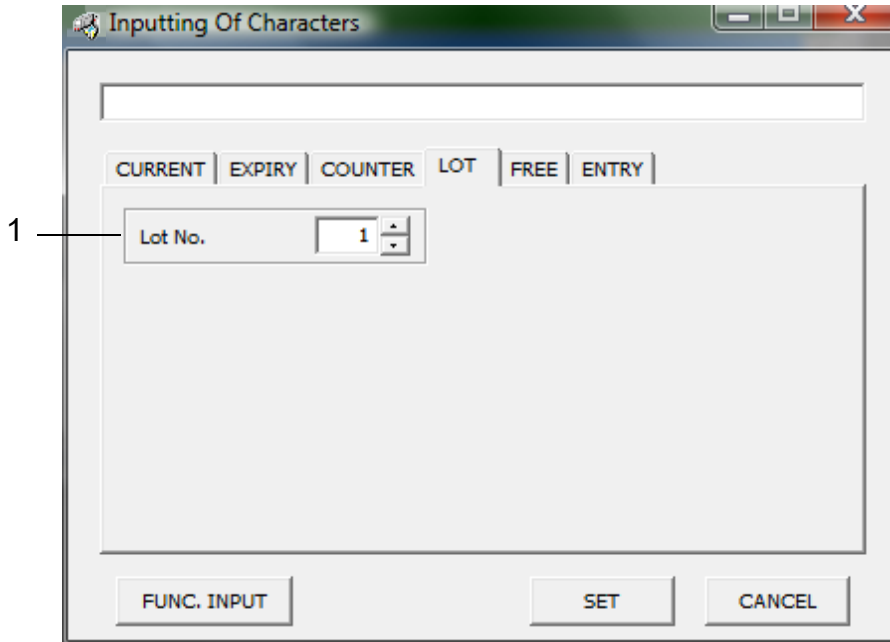

1 Lot No. : Sets the lot No. with  button. The setting range is selectable among 1 to 4.

■ Setting Flow

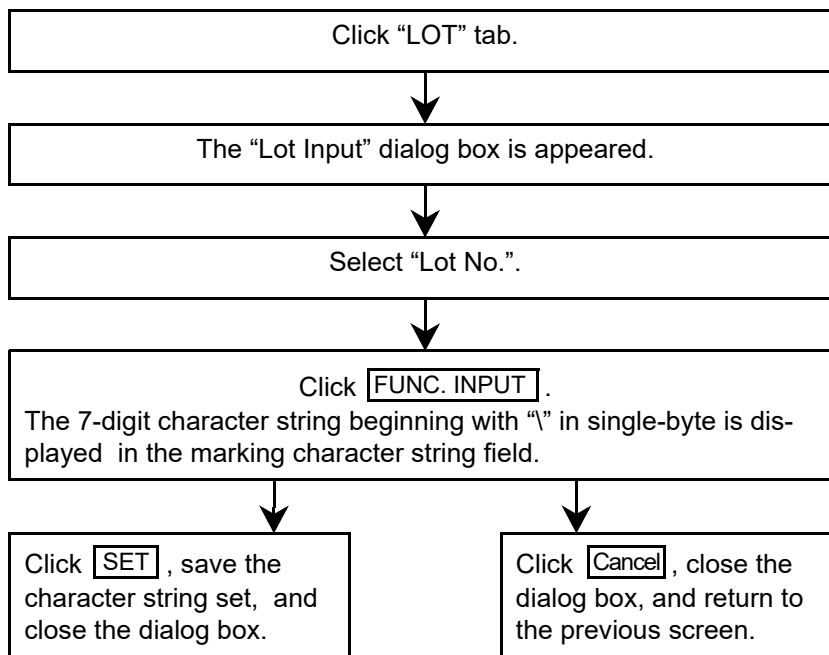

(Display Sample)

\ % S F T : 1
↓ ↓ ↓
1 2 3

	Display	Description
1	%	Indicates the functional character string.
2	SFT	Indicates the function character for lot.
3	*	“*” is varied in accordance with the lot function No. (1 to 4).





The lot function is referred to the marking function that marks the character string set with a certain duration. Refer to “3-4-4 Setting of Lot Function” (P.107) for details.

(5) Input optional character string

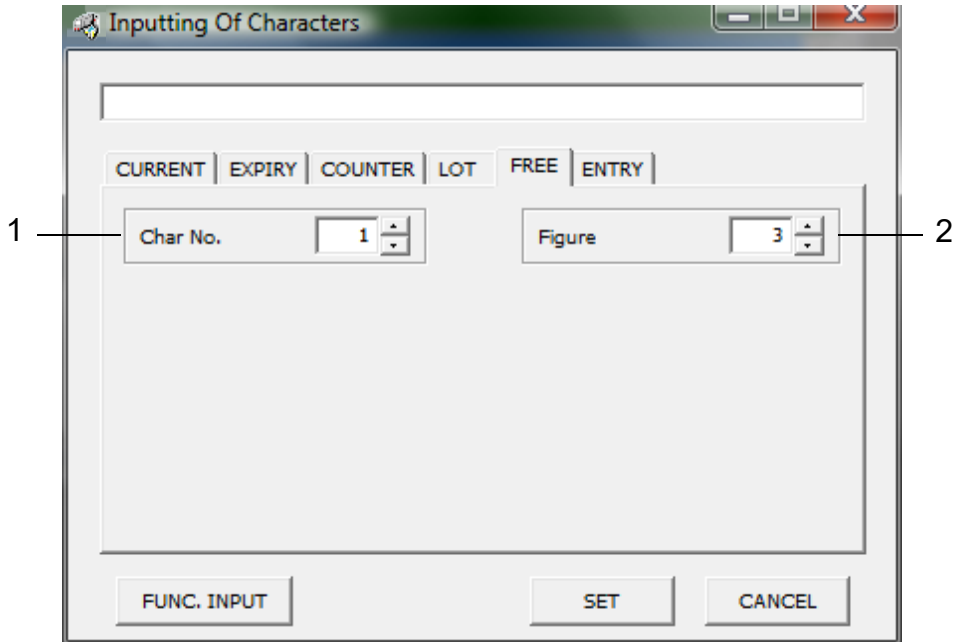
Outline : Function for marking the optional character string in the ASCII code using the communications from the external device such as PLC.



- 1 Char No. : Sets the character No. with  button. The setting range is selectable among 1 to 4.
- 2 Figure : Sets the figure with  button. The setting range is selectable among 1 to 30.

If the user tries to set the character string No. that has already been set in a file, the warning shown below is appeared.

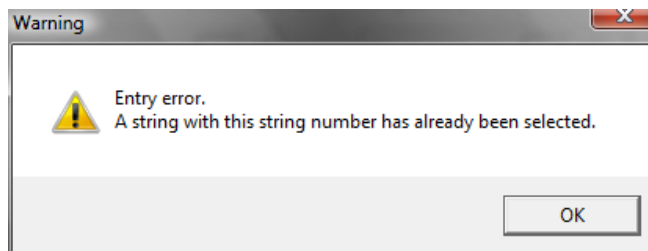

Click "OK" button to change the character string No. not set yet.



The optional character string (character string Nos. 1 to 4) can be applied to the registration file (1 to 120 marking files) in common.

■ Setting Flow

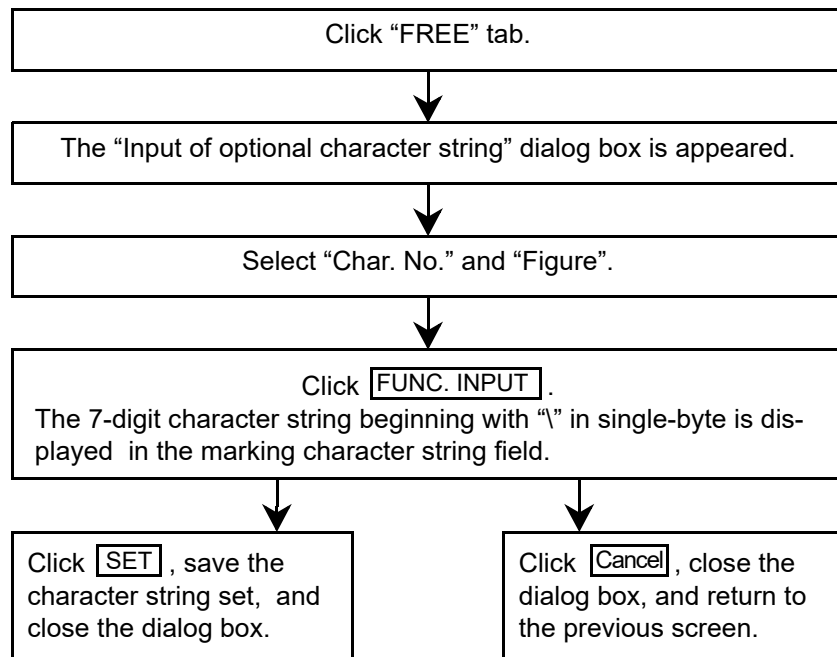

(Display Sample)

\ % 0 3 : A 1
 ↓ └──┬──┘ ↓ ↓
 1 2 3 4

	Display	Description
1	%	Indicates the functional character string.
2	**	Indicates the figure (01 to 30) in "***".
3	A	Indicates the function character for optional character string.
4	*	"*" is varied in accordance with the character string No. (1 to 4).



REFERENCE

The optional character string function is the function for marking the optional character string in the ASCII code using the RS-232C communication from the external device such as PLC. Refer to "4 External Control" (P.155) for details. Also, the image is displayed with "@" in the image display screen.

(6) Input registration character

Outline : Function for using the registration character registered in the user font.
(In case the registration character is not registered in the user font, nothing is displayed in the list.
In case of using the registration character, it needs to register the character beforehand.)

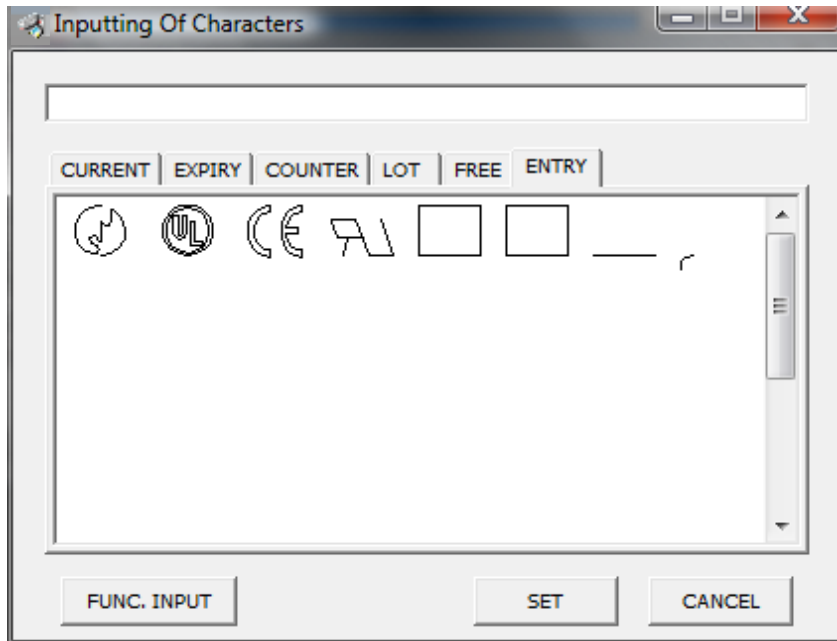

■ Setting Flow

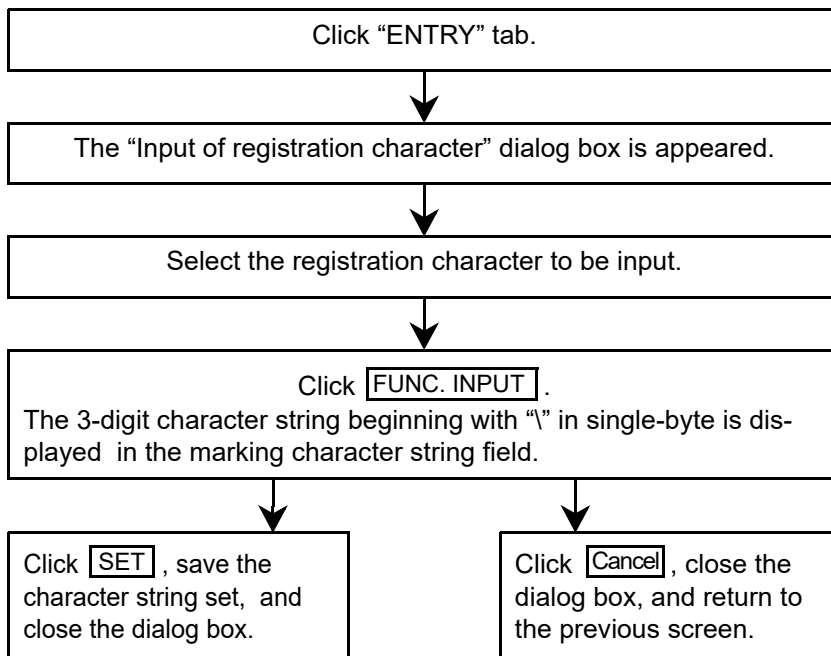

(Display Sample)

U 0
↓ ↓
1 2

	Display	Description
1	U	Indicates the registration character.
2	*	Indicates the registration character No. (0 to 9, A to Z, a to z) in the “*”.



- The registration character function is the function for using the registration character registered in the user font. Refer to “Character Code Table” (P.198) for detail content of the registration character at initial condition.
- Refer to “3-14-2 Environmental Setting Related to PC” (P.152) for details of the user font setting.
- It also is possible to input function by double-clicking the image of the registration character.



- In case of not registered the registration character in the selected user font, nothing is displayed.
- To create the new font as a “user registered character”, contact our sales office.

3-4 Function Setting

Here describes the function condition of the character string to be marked.

3-4-1 Function Setting Screen

The marking character is set and input on the “Function Setting” screen.

1 “View - “Set Func”

2 Click  .

The “Function Setting” dialog box is appeared by either selecting “1” method or clicking “2” button described above.

In this dialog box, there are three tabs, “EXPIRY”, “COUNTER”, and “LOT” as shown in the following figure and each function is set in this dialog box.

The content set in this dialog box is reflected to the character setting.

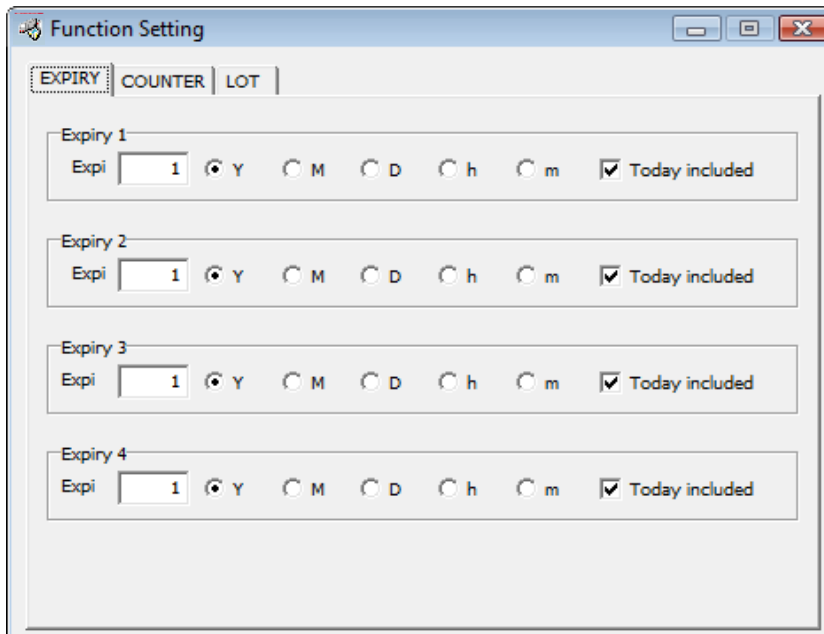

The image shows a screenshot of the "Function Setting" dialog box. It has a title bar with "Function Setting" and standard window controls. Below the title bar are three tabs: "EXPIRY" (selected), "COUNTER", and "LOT". The main area contains four sections, each labeled "Expiry 1" through "Expiry 4". Each section has an "Expi" input field with the value "1", followed by radio buttons for "Y", "M", "D", "h", and "m". The "Y" radio button is selected in all sections. To the right of each section is a checked checkbox labeled "Today included".

3-4-2 Setting of Expiry Date Function

The expiry date function is the function for adding the days to the expiry date to the current date/time set in the environmental setting.

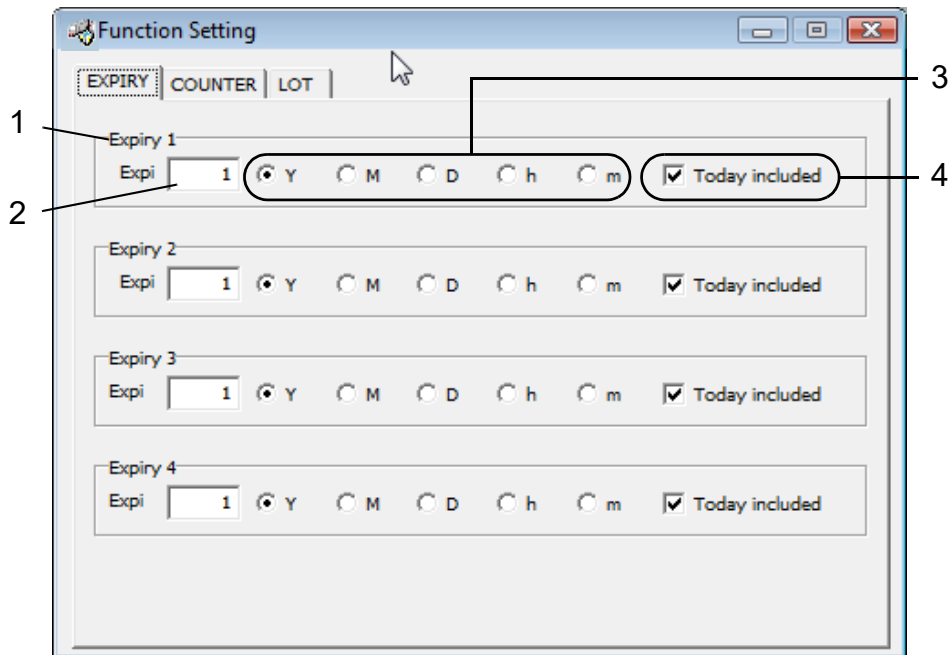

Item	Description
1. Expiry No.	Four expiry Nos. from 1 to 4 are available to be set.
2. Expi (Expiry)	The setting is available for the range from 1 to 999.
3. Unit	Selects one unit from “Y (Year)”, “M (Month)”, “D (Day)”, “h (hour)”, and “m (minute)” by checking the radio button.
4. Today included	Checking the “Today included” check box calculates the expiry including today. Note that when checking the unit among “D (Day)”, “h (hour)”, or “m (minute)”, this calculation including today is invalid.

3-4-3 Setting of Counter Function

The counter function is the function for increasing the value from the initial to the end value stepwise.

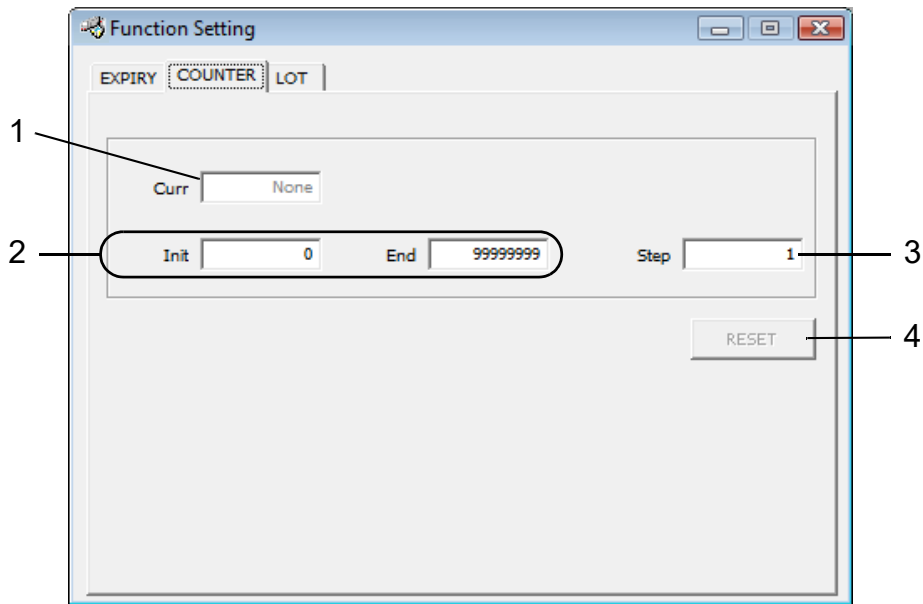

Item	Description
1. Curr (Current value)	Value of the current counter Setting range: 0 to 99999999
2. Init (Initial value)/ End (End value)	Initial value and end value of the counter. When determining each value, the counting is performed as follows. <ul style="list-style-type: none"> Initial value < end value : Count up Initial value > end value: The counter end is output and the counter does not count up. Setting range: 0 to 99999999
3. Step (Step value)	Input a value of increment. Setting range: 0 to 99999999
4. RESET	Sets the current value as the initial value. (The current value in the head is not updated.)

- When the current value is set out of the range defined by the initial and end values, the counter value is not marked, and the counter end signal is output.
- If the current value is reached to the end value, the external output counter end signal is output, the counter end output is reset with the next trigger, and the laser marker is performed marking from the initial value.
- When the PC itself is in operation and remote mode is selected as the control mode, the current value of the counter is impossible to be input.
- When changing the control mode from remote mode to PC control one, the PC gains all current values from the head. In this mode, the current counter value is possible to be input.
- The current counter value is transferred to the file transfer with the files.
- In test marking, the displayed current counter values are transferred, and they are gained again and displayed after completing the test marking.



- The value is not counted-up at test marking and guide display.

3-4-4 Setting of Lot Function

The lot function is the function for marking the character string set for each period in accordance with the internal clock in the laser marker.

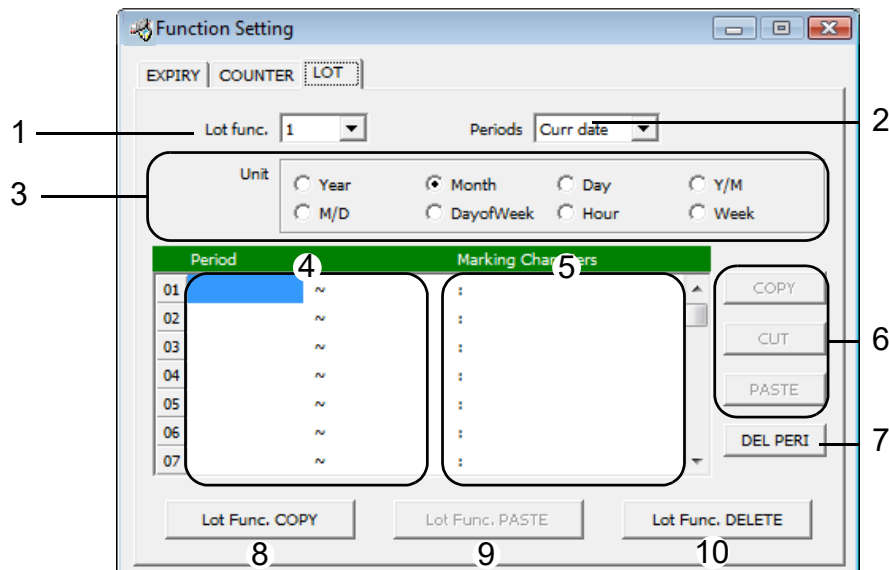

Item	Description
1. Lot Func. (Log Function)	Four types from 1 to 4 can be set.
2. Periods	Selects a target date from the list box. Current : Current Date Expiry 1 to 4 : Each expiry date set by Expiry No. 1 to 4
3. Unit	Selects the unit of the period set for the target lot by checking the radio button.
4. Period	Sets the start and end of the range including both ends (using min. and max.). The number of the segments, setting range, and setting method are varied depending on the selected "Unit".
5. Marking Characters	Sets the character string to be marked during the setting "Period".
6. COPY/CUT/PASTE	Copies, cuts, or pastes the selected character string.
7. DEL PERI (DELETE PERIOD)	Deletes the period and character string of the selected line.
8. Lot Func. COPY	Copies whole lot function.
9. Lot Func. PASTE	Pastes the copied whole lot function to the other lot function No.
10. Lot Func. DELETE	Deletes whole lot function.

<Number of segments and setting range>

Period condition	Max. number of segments	Setting range of period
Year	50	2000 to 2099
Month	12	1 to 12
Day	31	1 to 31
Y/M (Year-month)	50	Jan. 2000 to Dec. 2099
M/D (Month-day)	50	Jan. 1 to Dec. 31
Day of Week	7	Sunday to Saturday
Hour	24	0 to 23
Week	54	1 to 54

<Setting Method and Sample of Period>

The sample of the period setting method is shown as follows.

1. In case of selecting year, month, day, hour, or week for the period condition:

Function Setting

EXPIRY | COUNTER | LOT

Lot func. 1 Periods Curr date

Unit

Year Month Day Y/M

M/D DayofWeek Hour Week

Period	Marking Characters
01	1 ~ 1 : A
02	2 ~ 2 : B
03	3 ~ 3 : C
04	4 ~ 4 : D
05	5 ~ 5 : E
06	6 ~ 6 : F
07	7 ~ 7 : G

Lot Func. COPY Lot Func. PASTE Lot Func. DELETE

<Sample with the period condition "M (month)">

Input the period into the input field within the setting range of each period condition in single-byte character. Input the character string to be marked into the input field of "Marking Characters" within 10 letters. (Input the character in double-byte for Japanese OS and in single-byte for English OS.)

2. In case of selecting Y/M (year-month) or M/D (month-day) for the period condition:

Function Setting

EXPIRY | COUNTER | LOT

Lot func. 1 Periods Curr date

Unit

Year Month Day Y/M

M/D DayofWeek Hour Week

Period	Marking Characters
01	2009 / 1 ~ 2009 / 3 : A1
02	2009 / 4 ~ 2009 / 6 : A2
03	2009 / 7 ~ 2009 / 9 : A3
04	2009 / 10 ~ 2009 / 12 : A4
05	2010 / 1 ~ 2010 / 3 : B5
06	2010 / 4 ~ 2010 / 6 : B6
07	2010 / 7 ~ 2010 / 9 : B7

Lot Func. COPY Lot Func. PASTE Lot Func. DELETE

<Sample with the period condition "Y/M (year-month)">

Input the period into the input field within the setting range of each period condition in single-byte character. Input the character string to be marked into the input field of the marking character string within 10 letters. (Input the character in double-byte for Japanese OS and in single-byte for English OS.)

3. In case of selecting Day of Week for the period condition:

Period	Marking Characters
01 Sunday ~	Sunday : SUN
02 Monday ~	Friday : W.D
03 Saturday ~	Saturday : SAT
04 ~	: A4
05 ~	: B5
06 Sunday ~	: B6
07 Monday ~	: B7

<Sample with the period condition "Day of Week">

Click the input field of the period. The list box is displayed and a day of the week can be selected from it. Input the character string to be marked into the input field of the marking character string within 10 letters. (Input the character in double-byte for Japanese OS and in single-byte for English OS.)



- If the period condition is changed, all the preset periods are deleted.
- In case of setting 15 to 17 with the period condition set on "Hour", it means that the period is "between 15:00 to 17:59".
- If the period is required to set from 22 (o'clock) to 3 (o'clock, the next day), the user needs to divide the period condition into two periods such as 22 to 23 and 0 to 3.

3-5 Marking Condition

3-5-1 Setting Screen of Marking Condition

Here describes the conditions for marking character string and CAD file.

1 “View” - “Condition”

2 Click  .

The “Marking Condition” dialog box is appeared by clicking either selecting “1” method or clicking “2” button described above.

In this dialog box, there are 4 tabs, “GENERAL”, “CHARACTER”, “CAD”, and “LASER”, and each condition is set in each tab.

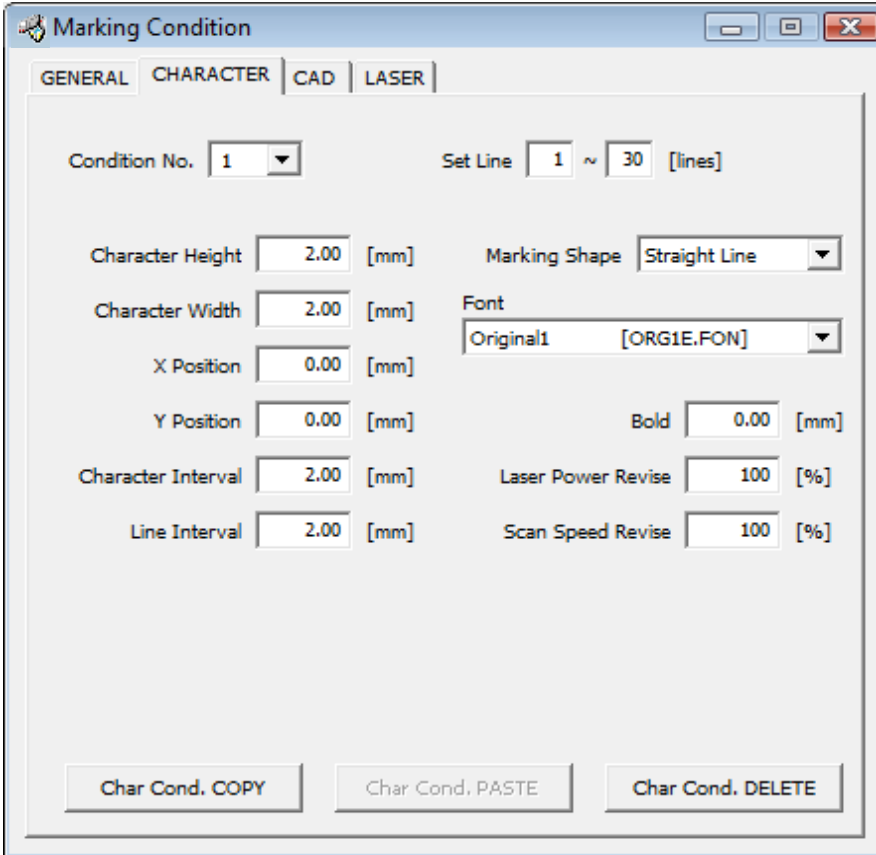

The image shows a screenshot of the "Marking Condition" dialog box. The dialog has a title bar with a close button and a maximize button. It contains four tabs: "GENERAL", "CHARACTER", "CAD", and "LASER". The "GENERAL" tab is selected. The dialog contains the following fields and controls:

- Condition No.
- Set Line ~ [lines]
- Character Height [mm]
- Character Width [mm]
- X Position [mm]
- Y Position [mm]
- Character Interval [mm]
- Line Interval [mm]
- Marking Shape
- Font [ORG1E.FON]
- Bold [mm]
- Laser Power Revise [%]
- Scan Speed Revise [%]

At the bottom of the dialog, there are three buttons: "Char Cond. COPY", "Char Cond. PASTE", and "Char Cond. DELETE".

3-5-2 General Conditions

On the GENERAL screen, set the offset of the marking position and inversion of the marking for all character strings including in the file or CAD file.

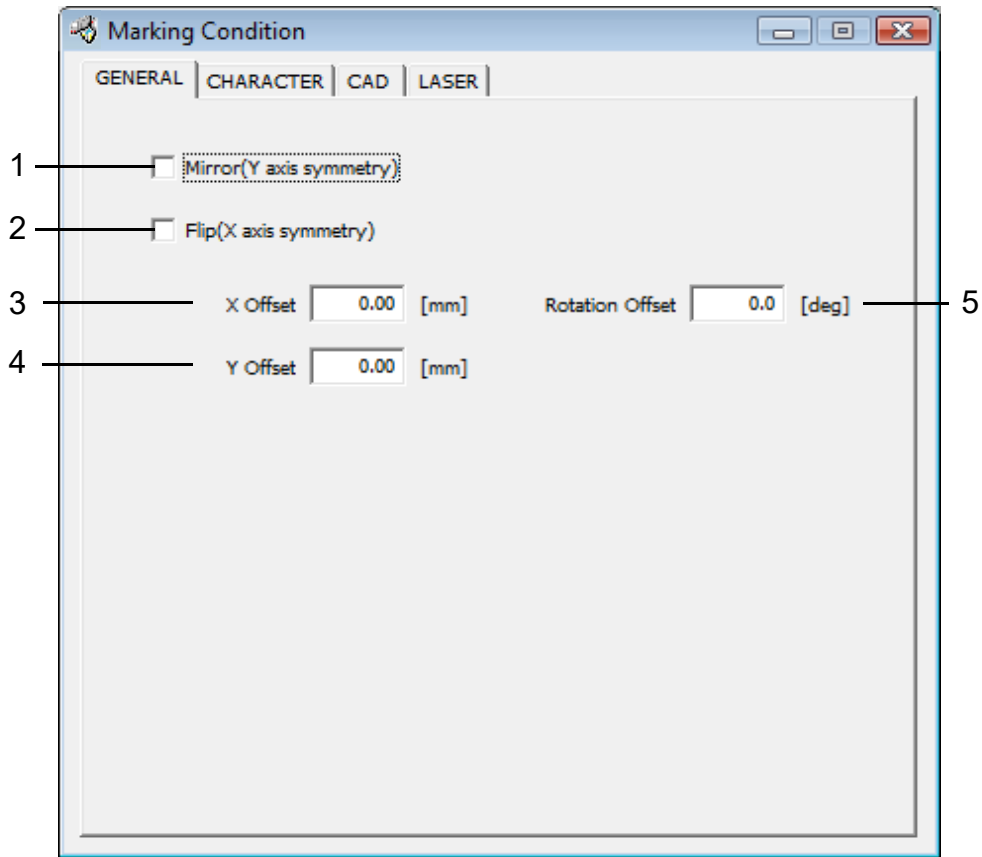

Item	Description	Setting range
1. Mirror (Y axis symmetry)	Marks the character string or CAD file at a position symmetric to the Y axis.	Check box
2. Flip (X axis symmetry)	Marks the character string or CAD file at a position symmetric to the X axis.	Check box
3. X Offset	Moves the origin in X direction.	+/-25.00mm (Step: 0.01mm)
4. Y Offset	Moves the origin in Y direction.	+/-25.00mm (Step: 0.01mm)
5. Rotation Offset	Rotates the character around the origin with the counterclockwise direction is defined as forward rotation direction.	+/-180.0° (Step: 0.1°)

(1) Mirror inversion

The mirror inversion has two types, horizontal inversion (Mirror) and vertical inversion (Flip).

- “Mirror” Horizontal mirror inversion (Y axis symmetric)
All character strings and CAD files are marked at the position symmetric to Y axis.
- “Flip” Vertical mirror inversion (X axis symmetric)
All character strings and CAD files are marked at the position symmetric to X axis.

Both horizontal and vertical inversions are available to be set simultaneously.
The relation between the respective check box set ON/OFF and image indication is as follows.

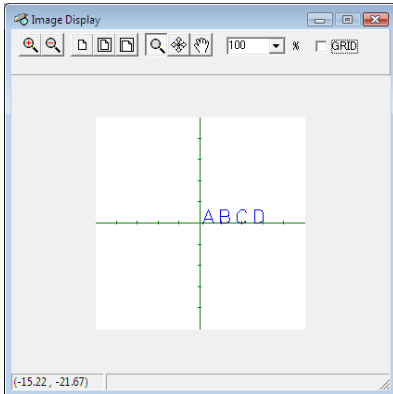

Mirror (Y axis symmetric): OFF
Flip (X axis symmetric) : OFF

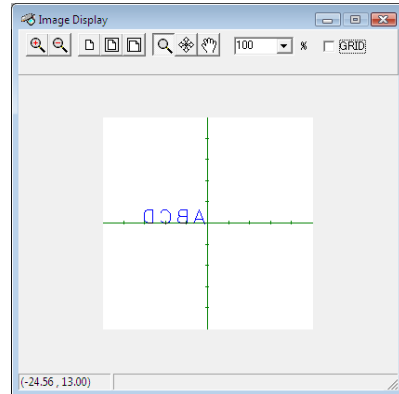

Mirror (Y axis symmetric): ON
Flip (X axis symmetric) : OFF

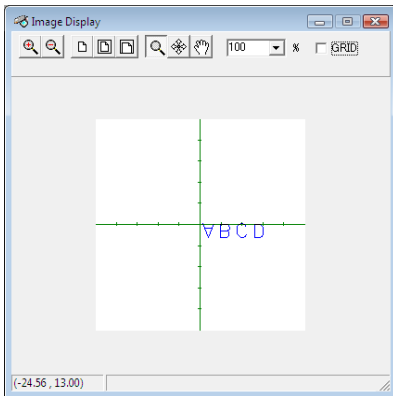

Mirror (Y axis symmetric): OFF
Flip (X axis symmetric) : ON

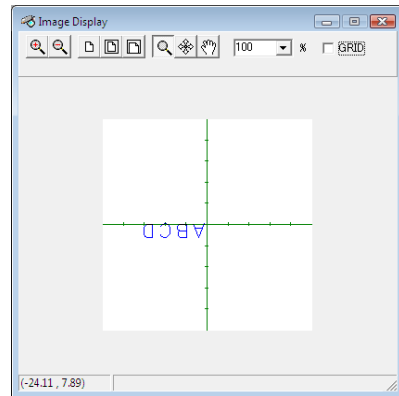

Mirror (Y axis symmetric): ON
Flip (X axis symmetric) : ON

(2) Offset

The offset has three types, X offset, Y offset, and Rotation offset.

- X/Y offset

X offset moves the origin in X direction, and Y offset moves the origin in Y direction.

Setting range: -25.00 to +25.00mm

Step : 0.01mm

- Rotation offset

The rotation offset rotates the character around the origin in the counterclockwise direction is defined as the forward rotation direction.

Setting range: -180.0 to +180.0°

Step : 0.1°



Even if X/Y offset or rotation offset is applied, the X and Y axes in the image display screen are not moved.

The X/Y offset and rotation offset can be set simultaneously.
The setting sample of each offset is shown as follows.

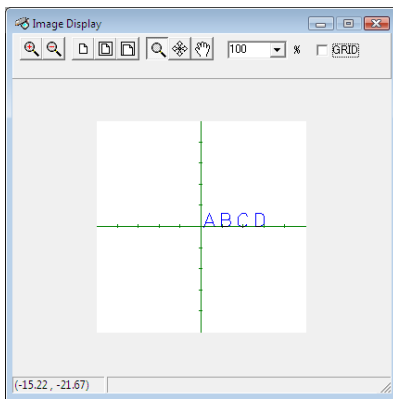

Rotation Offset : 0.0°
X Offset : 0.00mm
Y Offset : 0.00mm

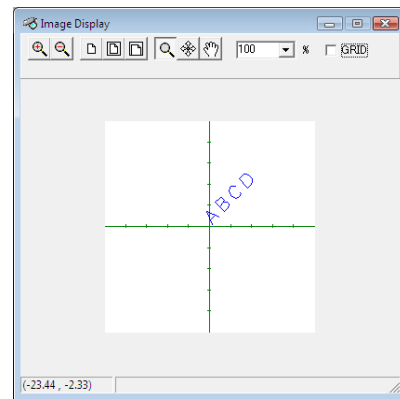

Rotation Offset : 45.0°
X Offset : 0.00mm
Y Offset : 0.00mm

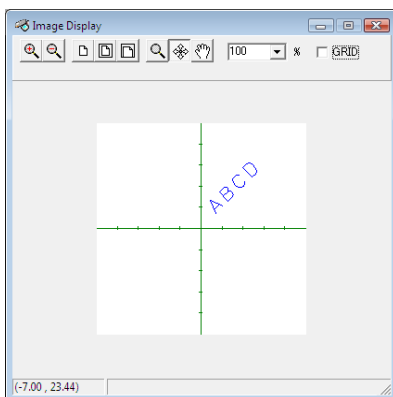

Rotation Offset : 45.0°
X Offset : 3.00mm
Y Offset : 3.00mm



REFERENCE

Both the mirror inversion and the offset can be set simultaneously.



CHECK

General conditions are set for correcting misalignment to the line axis caused when the laser marker is installed. Set this function to check the actual marking results and apply fine adjustment. If overall conditions are set before other conditions are set, it becomes difficult to set the character conditions and CAD conditions.

3-5-3 Character Condition

On the character setting screen, set the shape of marking, size and position of character for the marking character string in the respective lines of the character setting.

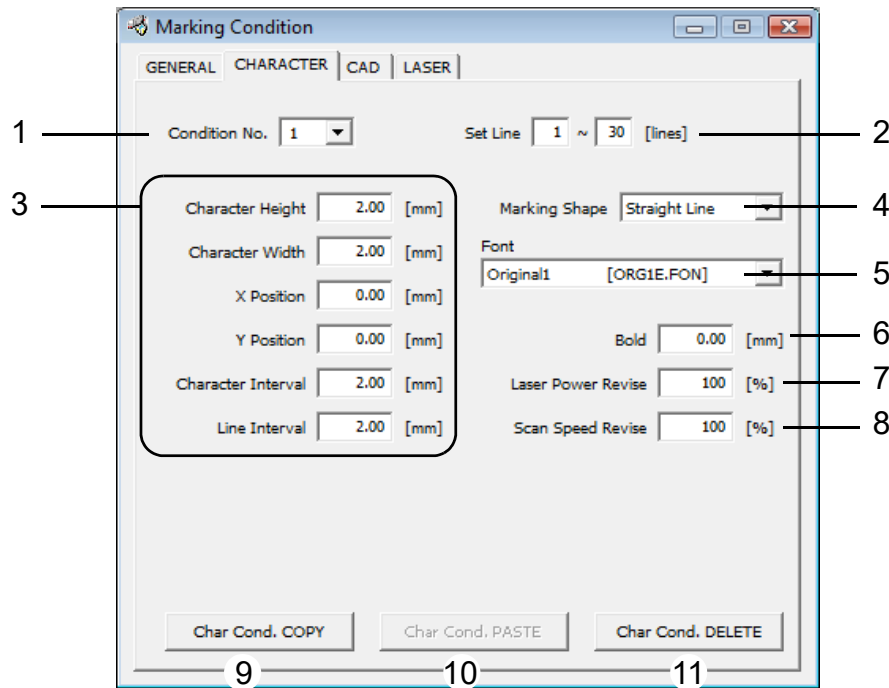

Item	Description	Setting Range
1. Condition No.	Enables to set the character condition for each condition No. Select the condition No. using the list box.	1 to 30
2. Set Line	Specifies the lines which are set for the marking character strings of the character setting screen. When inputting the start line and ending line, the character conditions between these two lines become effective.	1 to 30 for both start/end lines
3. Character Setting Part	Enables to set the size and position of the character. This part changes the items to be set depending on the selected marking shape.	Refer to 3-5-3 (1).
4. Marking Shape	Selects the design of the character string among "Straight Line", "Tilt Angle" and "Fan Line Form".	Select the shape using the list box.
5. Font	Selects the font file to be used for displaying the marking character string of each line by setting software and marking the character string by the laser marker.	Select the font using the list box.
6. Bold	Enables to set the thickness of the character stroke.	0.00mm to 6.00mm (Step: 0.01mm)
7. Laser Power Revise	Enables to set the correction against the laser power set on the laser setting screen.	0 to 200%
8. Scan Speed Revise	Enables to set the correction against the scan speed set on the laser setting screen.	50 to 200%
9. Char Cond. COPY	Copies whole character condition.	-
10. Char Cond. PASTE	Pastes the whole character condition copied to the condition with other condition No. Note that the set lie is not copied.	-
11. Char Cond DELETE	Deletes whole character condition.	-



If the setting lines are duplicated with those with the different condition No., the setting with the smaller condition No. is effective.

(1) Marking shape and character setting

The character setting items are varied depending on the selected marking shape. Here describes the character conditions to be set for each marking shape.

1. Straight Line

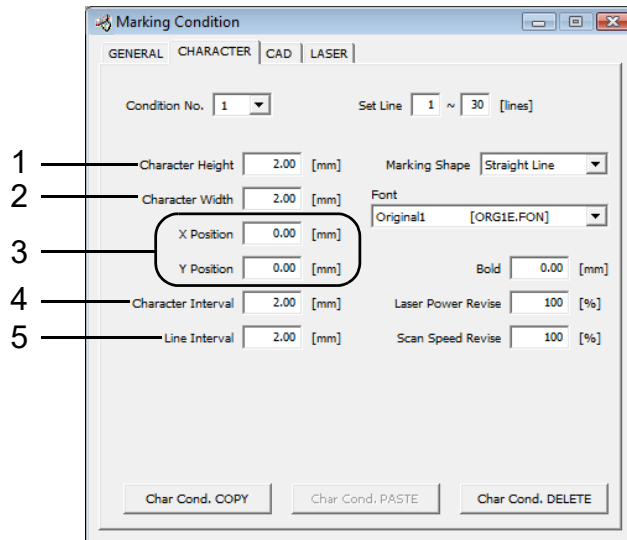
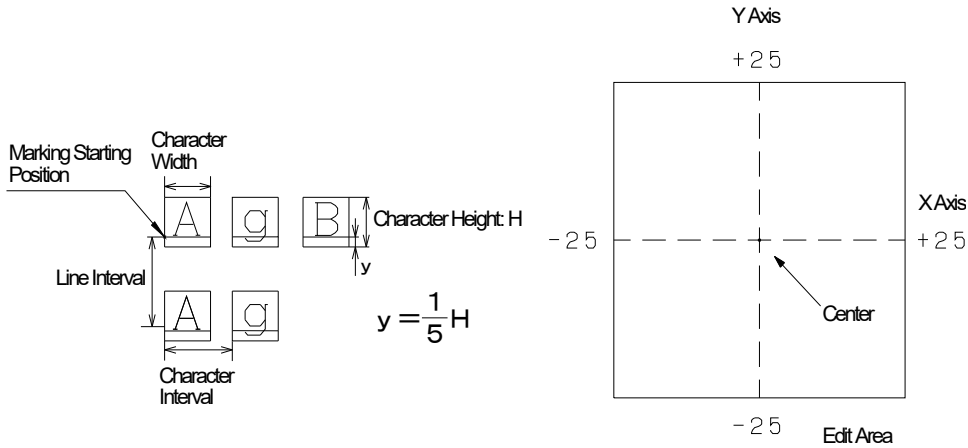

Item	Description	Setting Range
1. Character Height	Sets the character height.	0.20 to 50.00mm (Step: 0.01mm)
2. Character Width	Sets the character width.	0.20 to 50.00mm (Step: 0.01mm)
3. X/Y Position	Moves the marking start position of the character string in the X direction for the X position setting and in the Y direction for the Y position setting.	+/-25.00mm (Step: 0.01mm)
4. Character Interval	Sets the pitch between one character and another character.	0.00 to 25.00mm (Step: 0.01mm)
5. Line Interval	Sets the interval between one line and another line.	0.00 to 25.00mm (Step: 0.01mm)

2. Tilt

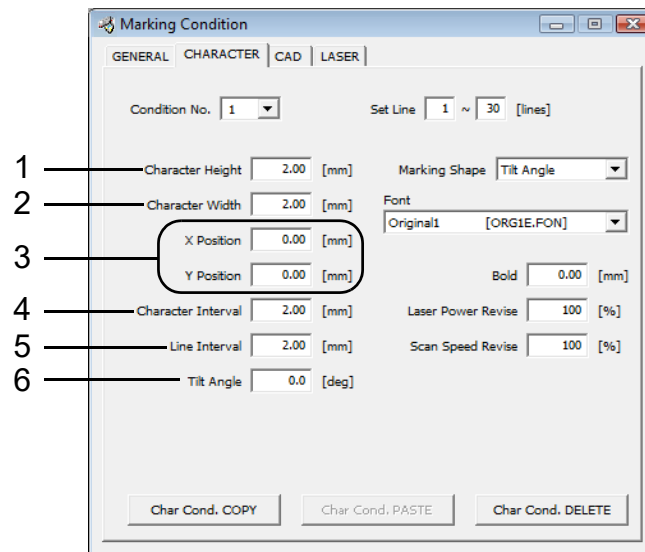
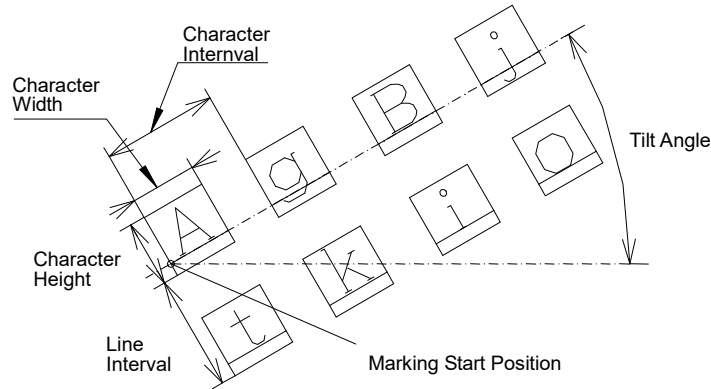

Item	Description	Setting Range
1. Character Height	Sets the character height.	0.20 to 50.00mm (Step: 0.01mm)
2. Character Width	Sets the character width.	0.20 to 50.00mm (Step: 0.01mm)
3. X/Y Position	Moves the marking start position of the character string in the X direction for the X position setting and in the Y direction for the Y position setting.	+/-25.00mm (Step: 0.01mm)
4. Character Interval	Sets the pitch between one character and another character.	0.00 to 25.00mm (Step: 0.01mm)
5. Line Interval	Sets the interval between one line and another line.	0.00 to 25.00mm (Step: 0.01mm)
6. Tilt Angle	Rotates the characters around the marking start position. The counterclockwise direction is the forward direction.	+/-180.0° (Step: 0.1°)

3. Fan Like Form (Clockwise circle outside, counterclockwise circle inside)

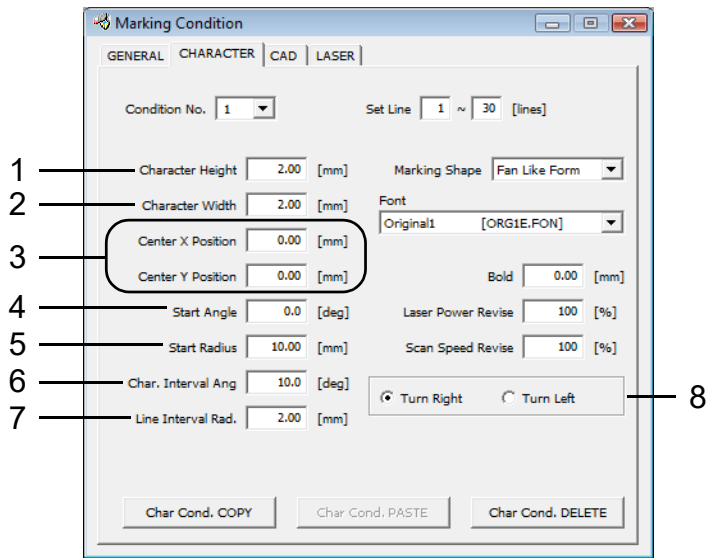
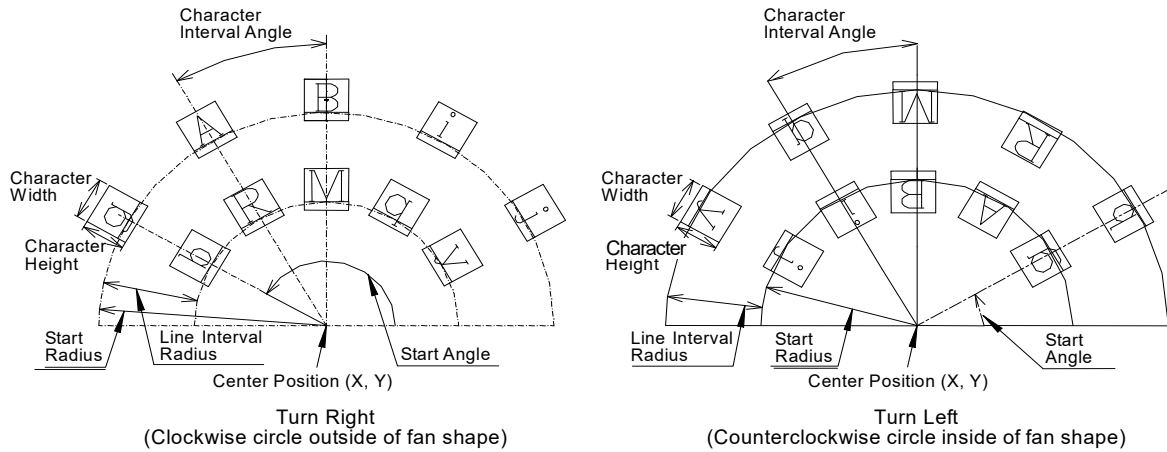

Item	Description	Setting Range
1. Character Height	Sets the character height.	0.20 to 50.00mm (Step: 0.01mm)
2. Character Width	Sets the character width.	0.20 to 50.00mm (Step: 0.01mm)
3. Center Position X/Y	Sets the center position of the arc.	+/-300.00mm (Step: 0.01mm)
4. Start Angle	Sets the angle from the center position X/Y with the reference position be set on the top character of the first line of the setting line.	+/-180.0° (Step: 0.1)
5. Start Radius	Sets the radius of the arc around the center position (X/Y)	0.00 to 300.00mm (Step: 0.01mm)
6. Character Interval Angle	Angle between one character and another character.	+/-180.0° (Step: 0.1°)
7. Line Interval Radius	Sets the pitch between one line and another line.	0.00 to 25.00mm (Step: 0.01mm)
8. Turn Right (Clockwise circle outside of fan shape)/Turn Left (Counterclockwise circle inside of fan shape)	Sets the items of clockwise circle outside of fan shape and counterclockwise circle inside of fan shape.	Check box

(2) Bold

Set the bold width of the character stroke.

Setting range: 0.00 to 6.00mm

(Note that this item max. available bold width of the character stroke must be one-fourth of whichever smaller one of character height and character width. In case of inputting larger value than this limit, the error message "Specify bold character line width in the range of 0.00 to ** [mm]." is appeared on the "Warning".)



In case of using the bold character marking function, it may influence the marking quality. Therefore, be sure to confirm the marking quality with the test marking, and then apply to the actual marking. In case of marking the bold character, set the value with the ratio of the character height against the character width be one-fourth to four.

(3) Laser power revise and scan speed revise

- Laser Power Revise : Setting of the correction for the laser power set on the laser setting screen in the range of the setting line.
Setting range: 0 to 200%
- Scan Speed Revise : Setting of the correction for the scan speed set on the laser setting screen in the range of the setting line.
Setting range: 50 to 200%



- If the value multiplied laser power correction by laser power is 100 or more, 100 is applied for the correction.
- If the value multiplied scan speed correction by scan speed is 2000mm/s or more, 2000mm/s is applied for the correction.

3-5-4 CAD Condition

On the CAD condition screen, the conditions for setting the marking of the data created by AutoCAD and so on (DXF file) are set.

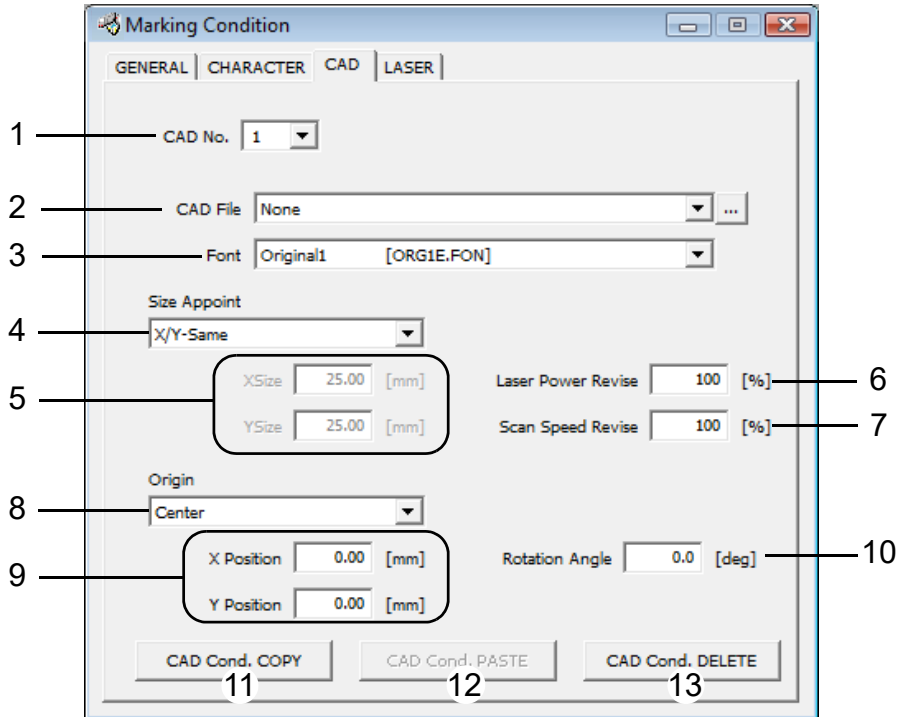

Item	Description	Setting Range
1. CAD No.	Selects the registration No. of the CAD data to be marked using the list box.	1 to 15
2. CAD File	Selects CAD file to be marked.	Select file using the list box.
3. Font	Selects the font to be used for displaying the character by the setting software and for marking by the laser marker in case that the character is used for each CAD file.	Select font using the list box.
4. Size Appoint	Specifies the method of either converting read image data with leaving the ratio between the height and width, or converting the data with specifying both the height and width (regardless of the ratio between the height and width).	<ul style="list-style-type: none"> • X/Y-Same • X/Y-Appoint • X-Appoint • Y-Appoint
5. Size	Specifies the size of X/Y directions of the rectangle to which a converted CAD data are circumscribed.	0.03 to 50.00mm (Step: 0.01mm)
6. Laser Power Revise	Enables to set the correction for the laser power set on the laser setting screen.	0 to 200%
7. Scan Speed Revise	Enables to set the correction for the scan speed set on the laser setting screen.	50 to 200%
8. Origin	Specifies which part of the graphic is aligned to the origin (0, 0) of the coordinate system.	Select 6 locations on a graphic.
9. X/Y Position	Moves the origin of the CAD file data in the X direction for the X position and in the Y direction for the Y position respectively.	+/-25.00mm (Step: 0.01mm)
10. Rotation Angle	Rotates CAD file data around the position of the origin. The counterclockwise direction is the forward direction.	+/-180.0 ° (Step: 0.1°)
11. CAD Cond. COPY	Copies the whole CAD condition.	-
12. CAD Cond. PASTE	Pastes the whole CAD condition copied to the condition with other CAD No.	-
13. CAD Cond. DELETE	Deletes whole CAD condition.	-

(1) CAD file

This item displays the list of the registered CAD file by clicking the list box. Click the file to be marked (DXF file) and specify the file. Note that when selecting “None (no CAD setting)”, no CAD file is set.



REFERENCE

Refer to “Character Code Table” (P.198) for details of the available CAD file.

1. Add the CAD file

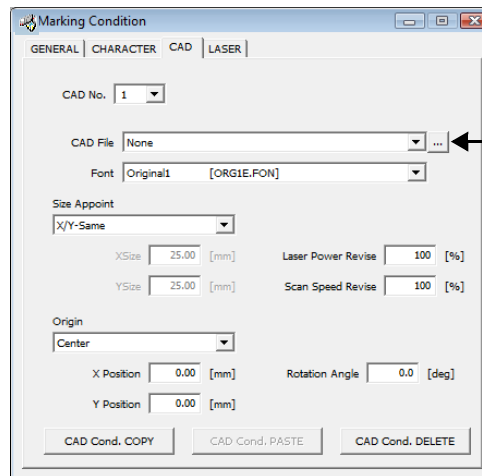

Add CAD file
button

The following dialog box is appeared by clicking  button on the right of the list box for CAD file. When selecting the location of the CAD file, the DXF file can be selected.

The selected file is copied to the folder named “Cad” under the folder installed the “PC setting software”.

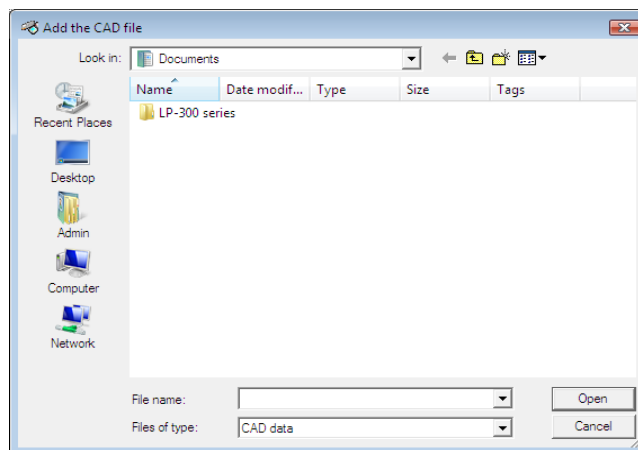

(2) Font

When the character is used for each CAD file, select the font for displaying a character by the setting software and marking by the laser marker from the registered font file.



A user font is used for the font file other than alphanumeric characters.



Refer to “3-14-2 Environmental Setting Related to PC” (P.152) for details of the setting method of the system font.

(3) Size Appoint

This item specifies the method of either converting the read image data with leaving the ratio between the height and width, or converting the data with specifying both the height and width (regardless of the ratio between the height and width). The following four types in the list box are available

“X/Y-Same”
“X-Appoint”

“X/Y-Appoint”
“Y-Appoint”



The “X/Y-Same” means that the size of the graphic of the read-in original CAD data is not changed.

- Length in X axis direction
Specify the size of the horizontal direction of the rectangle to which a converted CAD data are circumscribed.
If “Y-Appoint” or “X/Y-Same” is set in the size specification field, this item is invalid.
Setting range: 0.03 to 50.00mm
- Length in Y axis direction
Specify the size of the vertical direction of the rectangle to which a converted CAD data are circumscribed.
If “X-Appoint” or “X/Y-Same” is set in the size specification field, this item is invalid.
Setting range: 0.03 to 50.00mm

Conceptual Diagram of the Respective Length of Y and X Axes

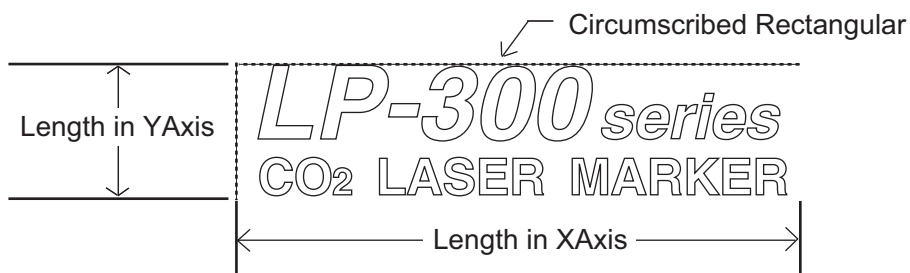

- Origin position specification

This item specifies which part of a graphic is aligned to the origin (0, 0) of the coordinate system. The whole graphic is shifted so that the specified part is aligned to the position of the origin. The following 6 types origin can be specified.

“Center”	“Left Down”	“Right Down”
“Left Up”	“Right Up”	“Same”

Conceptual Diagram Showing each Origin Position

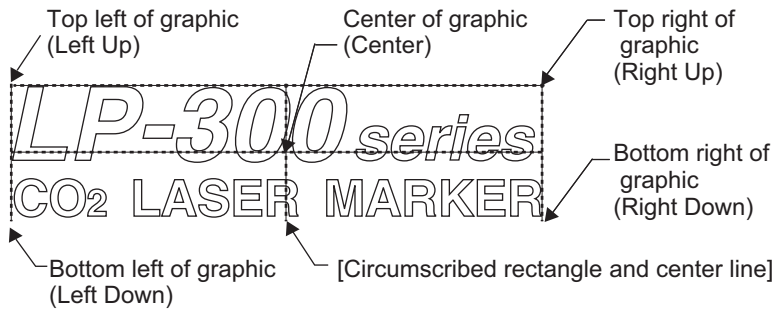

“Remain the original graphic” means that the position of the read-in original CAD data is not changed.

- X/Y Position

Move the original position of the CAD file data in the X and Y directions for the X and Y positions respectively.

Setting Range: -25.00 to +25.00mm

- Rotation Angle

Rotate the CAD file data around the original position. The counterclockwise direction is the forward direction.

Setting Range: -180.0 to +180.0 °



Some graphics cannot be marked as displayed in the image display if a DXF file created by AutoCAD is read in by the setting software. Refer to “Readable DXF File” (P.207) for details of the correspondence table between the LP-310 setting software and the drawing function of AutoCad.

(4) Laser Power Revise and Scan Speed Revise

- Laser Power Revise : Adds the correction to the laser power of the setting line.
Setting Range: 0 to 200%
- Scan Speed Revise : Adds the correction to the scan speed of the setting line.
Setting Range: 50 to 200%



- If the value of the laser power correction multiplied by the laser power is 100 or more, the “100” is applied as the correction value.
- If the value of the scan speed correction multiplied by the scan speed is 2000mm/s or more, the “2000mm/s” is applied as the correction value.

3-5-5 Laser Check

The laser beam for the laser check is continuously emitted to a desired spot in the marking area.

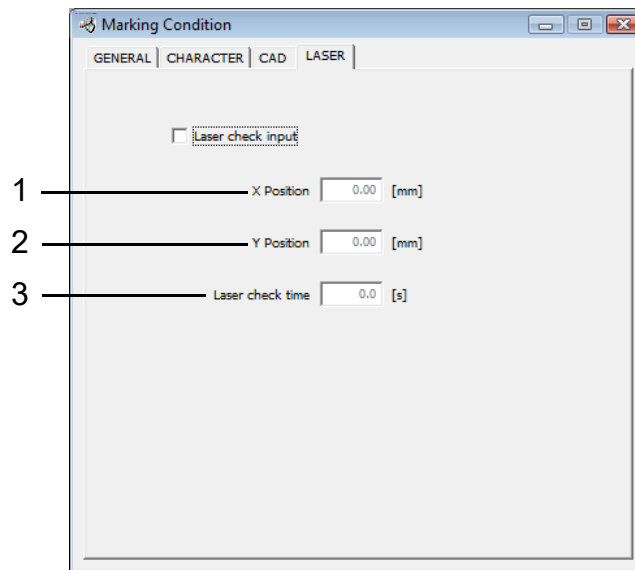

Item	Description	Setting Range
1. Laser check input	Specifies the laser check.	Check box
2. X/Y Position	Specifies the position of the laser check.	+/-25.00mm (Step: 0.01mm)
3. Laser check time	Sets the time of the laser check.	0.0 to 60.0s (Step: 0.1s)

The laser check is regarded as one of the marking file.

Refer to the following items.

1. When the laser check is ON, the other marking object (marking character character string, CAD file) cannot be set.
2. When the laser check is ON with the following windows, "Character Setting", "Function Setting", and "Image Display" be opened, these windows are closed forcibly. However, since the data is remained, open these windows again after the laser check is OFF.
3. When marking with the laser check, perform TRIG.IN or test marking after transferring the file, just the same as the marking characters and CAD file.
4. The laser power for the laser check is reflected by the power set at "Laser Setting".



REFERENCE

When the laser check is ON under the following condition of "1" or "2". the warning dialog box "This operation is invalid because laser check is set." is displayed.

1. When "Character Setting", "Function Setting" or "Image Display" is selected.
2. When changing to the sheet of "Marking condition" - "GENERAL", "CHARACTER", or "CAD" (When the window of "Character Setting", "Function Setting" or "Image Display" is already opened, it is to be closed forcibly.)



CHECK

MEMO

3-6 Laser Setting

3-6-1 Screen for Laser Setting

The condition of the marking laser for marking a character string or CAD file is set on this screen.

1 “View” - “Set Laser”

2 Click  .

The “Laser Setting” dialog box is appeared by clicking either selecting “1” method or clicking “2” button described above.

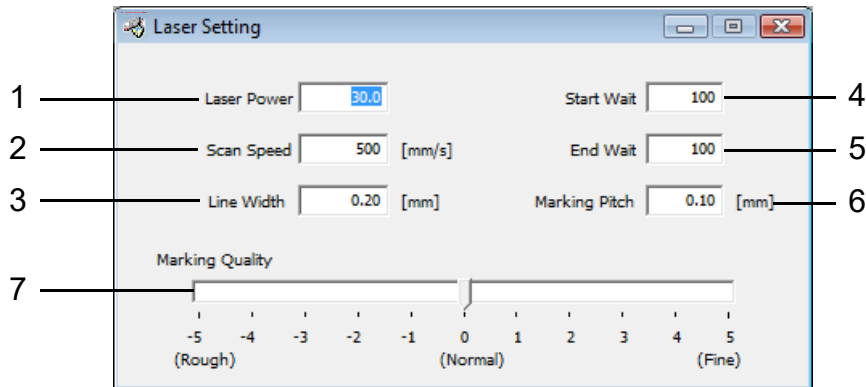

Item	Description	Setting Range
1. Laser Power	Sets the average output of the marking laser.	0.5 to 100.0 (Step: 0.5)
2. Scan Speed	Sets max. transfer speed of the laser spot.	1 to 2000mm/s (Step: 1mm)
3. Line Width	Sets the with of the stroke of the marked character.	0.01 to 2.00mm (Step: 0.01mm)
4. Start Wait	Adjusts the timing for turning ON the laser at the start point.	50 to 150 (Step: 1)
5. End Wait	Adjusts the timing for turning OFF the laser at the ending point.	50 to 150 (Step: 1)
6. Marking Pitch	Sets the density for marking a bold character.	0.00 to 2.00mm (Step: 0.01mm)
7. Marking Quality	Sets the number of segments of the stroke at a curve part stepwise.	Rough to fine 11 steps



- Even if the scan speed is doubled, the marking time is not reduced to a half.
- If the scan speed is too high, the characters may be distorted. Check the symptom at the test marking beforehand.

3-6-2 Line Width

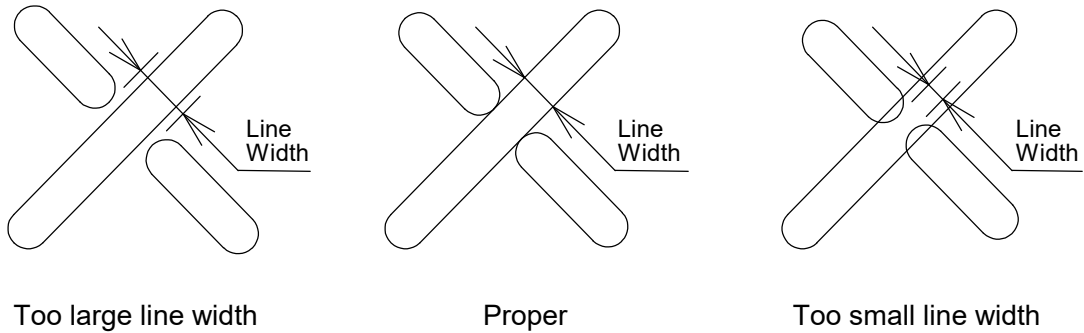

The line width is the setting value for creating the clearance at the intersection of the character strokes. The initial value of the line width is set so that the character strokes are not overlapped at the intersection in the case of general marking. However, if the initial value is applied to the actual character marking, the character strokes may be overlapped each other so that the character is engraved too deeply or characters strokes are so apart that clearance is created. In such cases, overlay at the intersection can be adjusted finely by changing the setting of the line width.

Setting Range: 0.01 to 2.00mm
Initial Value : 0.20mm



Even if the setting for the line width is adjusted, the width of the character stroke being marked is not changed.

3-6-3 Marking Pitch

This item sets the density of the marking of the bold character.

- Marking bold characters

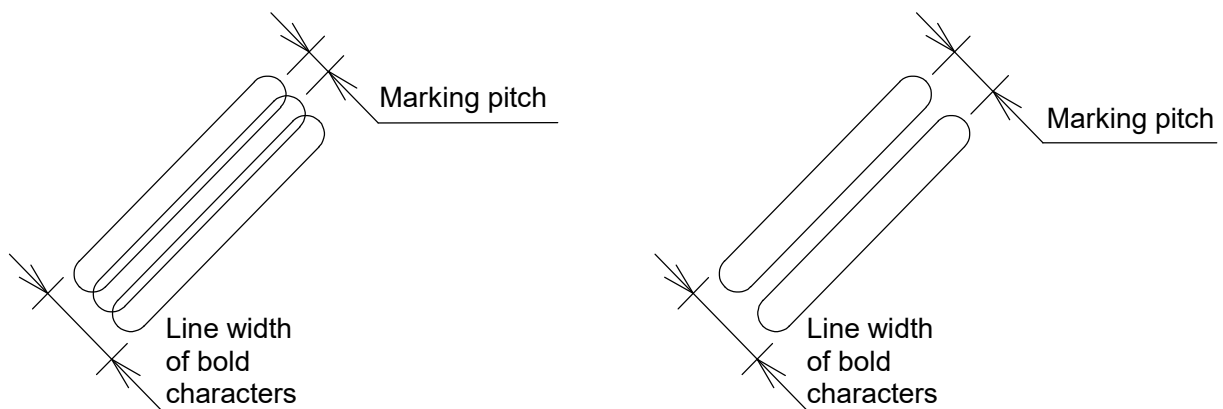

- The setting value of the “line width” is differed from the width of the actual marked strokes depending on the material of the work being marked. For marking with proper “line width” and “line width of bold character”, it is recommended to measure the line width of the marked one stroke, and then input the proper setting value of the “line width”.
- This correction is not effective for the CAD data.

3-6-4 Adjustment of Laser Start/End Points

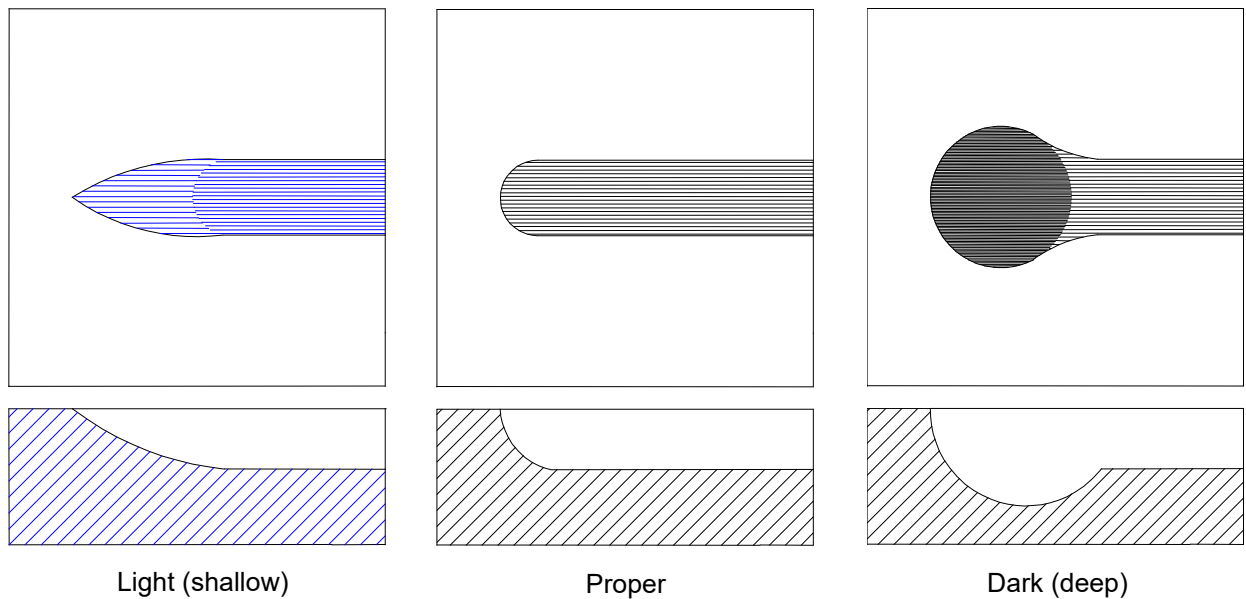

The depth, shape, visibility, etc. of the marking are changed depending on the type of the target object, scan speed, laser power, etc.

By using this function, the depth at the start/end points can be reduced and the marking shape can be adjusted.

- Laser start point adjustment

Adjusts the timing for turning on the laser at the start point.

The smaller the value is, the darker (deeper) the marked character at the start point is.

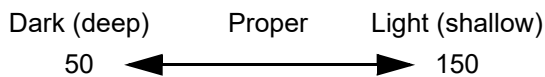

Setting Range: 50 to 150
Initial Value : 100

- Laser end point adjustment

Adjusts the timing for turning off the laser at the end point.

The larger the value is, the darker (deeper) the marked character at the end point is.

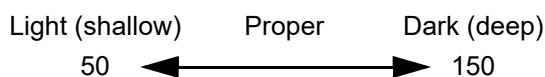

Setting Range: 50 to 150
Initial Value : 100

3-6-5 Adjustment of Marking Quality

This product marks the curved portion by dividing them into straight lines.
The roughness of the division can be set in eleven steps.



REFERENCE

When a small character is marked, the character looks a curve even if this parameter is set relatively rough. When a large character is marked, the character looks a distorted curve unless this parameter is set fine.



CHECK

The larger the value of the marking quality is, the longer the marking time becomes.

3-7 Image Display

3-7-1 Image Display Screen

This screen displays the marking image of the data that has been set.

1 “View” - “Image”

2 Click  Image

The “Image Display” dialog box is appeared by clicking either selecting “1” method or clicking “2” button described above.

(Here displays the created file.)

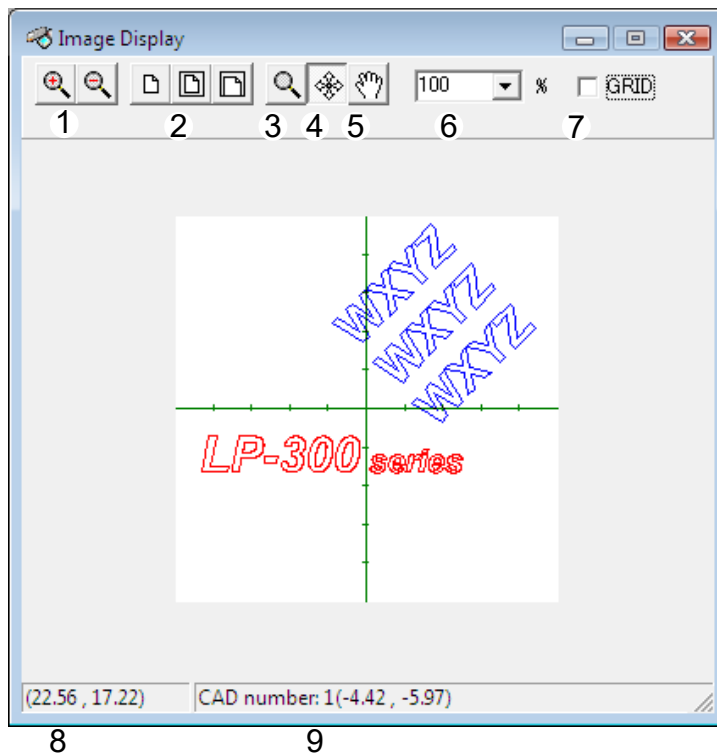

No.	Item	Description
1	Zoom-in/Zoom-out buttons	Zooms-in and zooms-out the image display by clicking the corresponding button.
2	Display Size	Displays the edit area in accordance with the window size of the image display (height or width).
3	Specify a range to zoom-in	Magnifies the scope specified with the selection window to the maximum size of image display.
4	Adjust the marking position	Moves the character string by dragging the image.
5	Adjust the display position	Adjusts the display position by dragging the edit area to a new position.
6	Magnification list box	Selects the desired magnification using the list box. Selectable magnification: 100 to 100000%
7	GRID	Sets the display/non-display of the grid with an interval of 5mm on an image display screen.
8	Mouse cursor coordinate	Displays the coordinate of the cursor with its center set as the origin.
9	Marking conditions	Displays both condition No. of the selected character string and the coordinate of the marking start position.

3-7-2 Magnification Method

(1) Zoom-in/out buttons and magnification list box

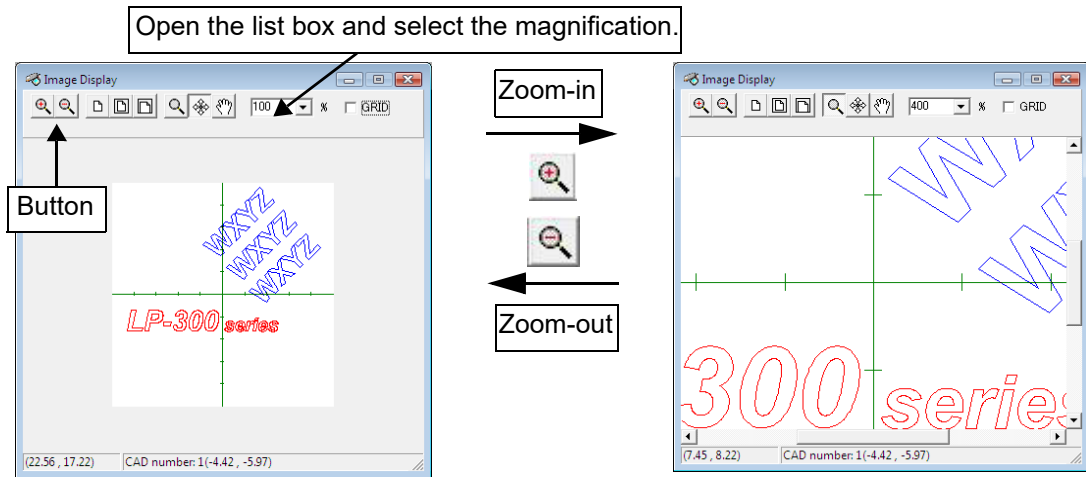

- Zoom-in/out buttons: Zooms in and out the image by clicking the corresponding button.
- Magnification list box: Selects a desired magnification for display from the list box.



The reference position of the zoom-in/out is set on the center of the image display screen.

(2) Magnification by the magnification function

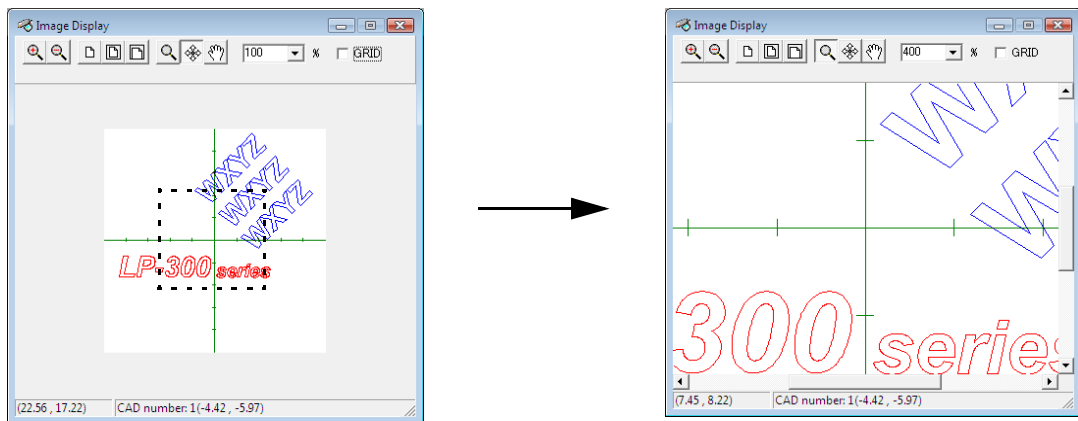

When clicking  button, the mouse cursor is changed into  icon.

With this state, click the left mouse button to specify the scope using the selection window (portion enclosed with dotted lines). Then, the selected scope is magnified to the full size of the image display dialog box by releasing the button.

3-7-3 Adjustment of Marking Position

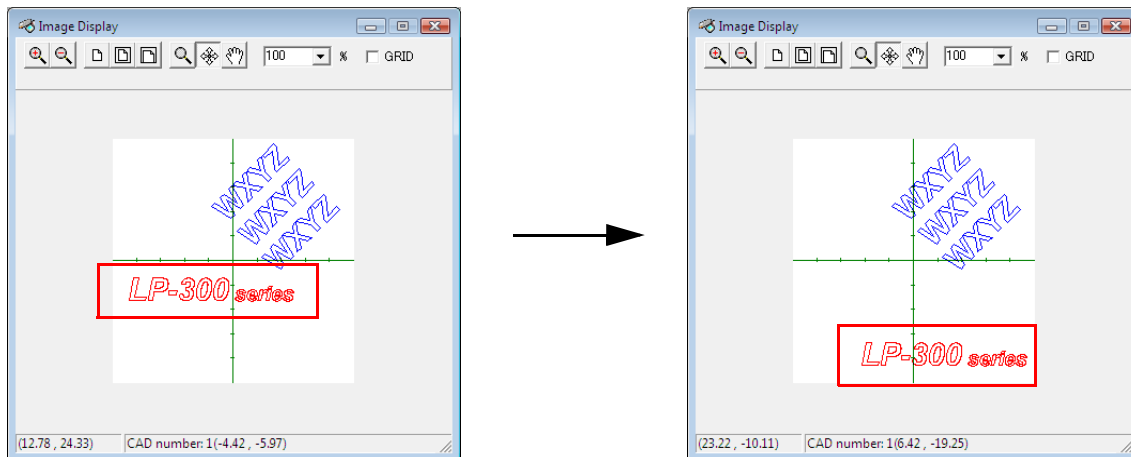

When clicking  button, the mouse cursor is changed.

With pressing the left button on the desired character string for moving, move the mouse to the desired position and release the button.

(The color of the selected character string is changed into red.)

- The selected character string can also be moved with the arrow keys.
 - Arrow key : The character string is moved per 0.01mm.
 - Shift + Arrow key : The character string is moved per 0.1mm.
- When clicking the right mouse button on the selected character string, the character setting screen and marking condition screen can be opened.



REFERENCE

- If the marking position is moved and the character string is moved out of the scope of the marking area, "Marking data has exceeded marking area" is displayed. Shift the character string into the scope of the marking area.
- The contents set in the character setting, function setting, and marking conditions screens are reflected onto the image display immediately. It is useful to keep displaying the image.

3-7-4 Adjustment of Display Position

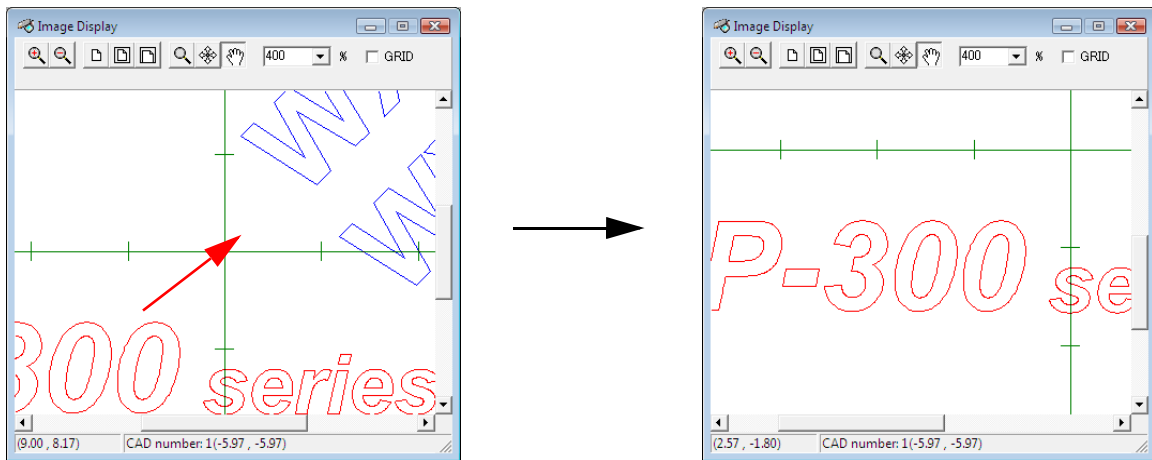

When clicking  button, the mouse cursor is changed.

With this state, press and hold the left mouse button on the image display and drag the image with the mouse to the desired position for display and release the mouse. The display position of the image is moved.

The indication of the center position and actual marking character string can be traced (guide indication) on the actual work using the red laser.

The operation of the guide indication is performed in PC control mode.



- When activating the guide indication, perform the guide indication with the shutter (guide indication switching lever) closed.
- Since the power of the guide laser is 1mW or less (red), work is not processed in almost all cases. However, the color change may be caused on an object sensitive to red. Do not use the laser for guide indication for such object.
- When performing the guide indication, the file under editing is transferred to the head, and overwritten to the file with the same file No. in the head. Therefore, pay attention to the activation of the guide indication.

3-8-1 Center Position Indication

When the shutter (guide indication switching lever) is set to “CLOSE”, the marking center position is indicated with the red laser.



The guide laser is irradiated to the center of the marking area without using the guide indicating function by setting the shutter lever to “CLOSE”.

3-8-2 Guide Indication

1 “File” - “GUIDE”

2 Click  .

Select operation from either “1” or “2” described above.

When the shutter is set to “OPEN”, the dialog box that indicates the shutter is in open state is appeared. Click “OK”, set the shutter to “CLOSE”, and select the operation from either “1” or “2” described above.

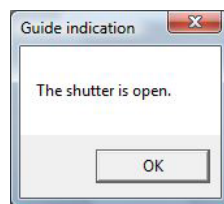

When the shutter is set to “CLOSE”, the dialog box indicating “Start of guide indication” is appeared.

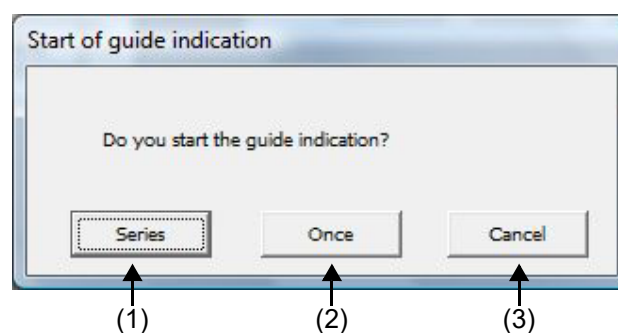

(1) Series

The guide indication is continuously performed with the laser marker.

When the file No. under editing on the PC is also existed in the head, the following dialog box for checking whether the file is allowed overwriting or not is displayed (if there exists no file with the same file No. in the head, this dialog box is not displayed).

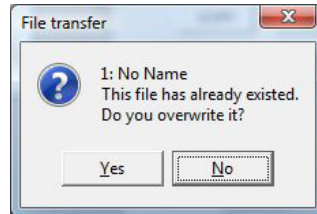

When selecting “Yes”, the file is transferred and the guide indication with red laser is started.

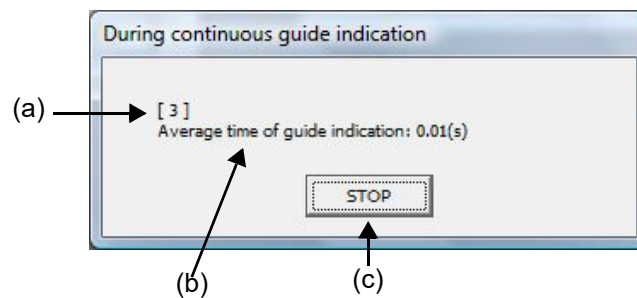

No.	Item	Description
(a)	[*]	Indicates the frequency (*) of the guide indication.
(b)	Average time of guide indication	Indicates the average time of the guide indication.
(c)	STOP	Ends the series guide indication.



If the accumulated time from the beginning of the series guide indication has been exceeded 1 minute, the guide indication is not executed again, and the series guide indication is finished. It is impossible to stop the guide indication halfway.

When clicking “STOP” button, the following dialog box is appeared.

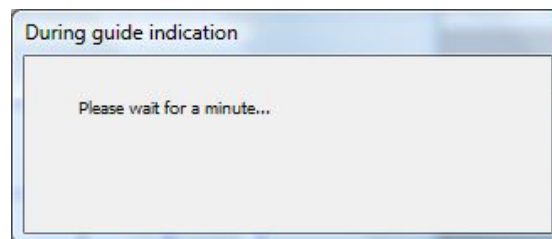

When finishing the guide indication, the dialog box indicating “During guide indication” is closed and then the dialog box indicating the finish of the guide indication “End of guide indication” is appeared. Besides, the guide indication time is also appeared.

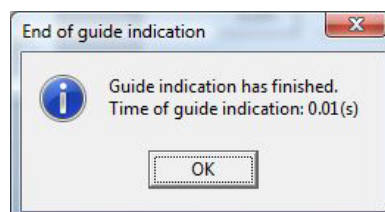

(2) Once

Perform the guide indication with the laser marker at one time.

When the file No. under editing on the PC is also existed in the head, the following dialog box for checking whether the file is allowed overwriting or not is displayed (if there exists no file with the same file No. in the head, this dialog box is not displayed).

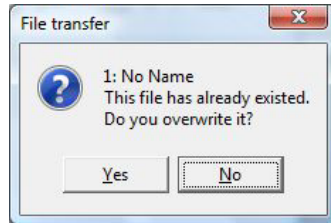

When selecting "Yes", the file is transferred and the guide indication with red laser is started. When finishing the guide indication, the dialog box indicating "During guide indication" is closed and then the dialog box indicating the finish of the guide indication "End of guide indication" is appeared. Besides, the guide display time is also appeared.

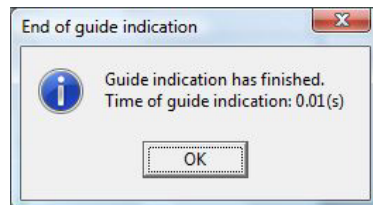

(3) Cancel

By clicking this button, the guide indication is canceled.

3-8-3 Cautions

It is impossible to perform the guide indication for an empty file (including no setting).

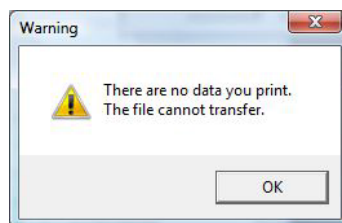

Click "OK" button, re-select the file, and select the operation from either "1" or "2".



The guide indication time is the guide of the actual marking time. In case of requiring the precise marking time, perform the marking using the external control (refer to Chapter 4), and measure the time using the marking start (trigger) signal and marking ending signal.

MEMO

3-9 Test Marking

3-9-1 Test Marking

The test marking is performed in PC control mode from the PC.



- When performing the test marking, set the shutter (guide indication switching lever) to “OPEN”.
- For some PC models, the dialog box below may be hidden behind the main screen of this software. Do not perform any key operation (Enter, Space, etc.) in this state. Display the dialog box in the front of the PC screen by clicking the software name (LP-310 setting software) displayed on the Windows task bar or via keyboard operations (“Alt” + “F6”, “Alt” + “Tab”), and click “Yes” to perform the test marking.
- Note that in test marking, the file under editing is transferred to the head and overwritten to the file with the same No. existing in the head.

1 “File” - “TEST”

2 Click 

Select the operation from either “1” or “2” for performing the test marking.

When the shutter is set to “CLOSE”, the dialog box indicating the shutter is in CLOSE state is appeared. Click “OK” button, set the shutter to “OPEN”, and perform either “1” or “2” operation again.

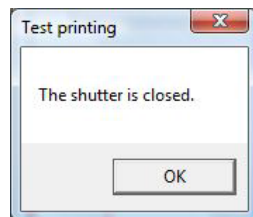

When the shutter is set to “OPEN”, the dialog box “Start of printing” is appeared.

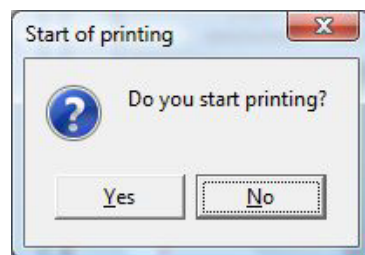

If the file No. under editing in PC is existed in the head, the following dialog box for checking whether the overwriting is allowed or not is appeared. (If there exists no file with the same fine No. in the head, this dialog box is not apperaed.)

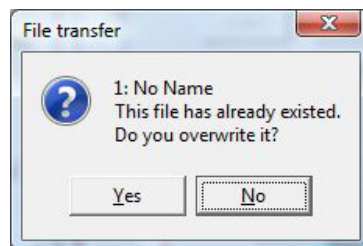

When selecting “Yes” in the dialog box “Start of printing”, the file is transferred and the test marking is started. After ending the test marking, the “End of printing” dialog box is appeared. Besides, the marking time is also displayed.

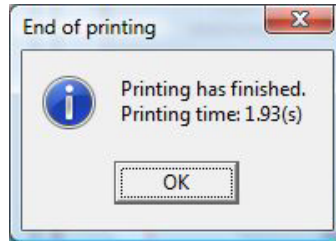

It is impossible to perform the test marking for an empty file (including no setting).

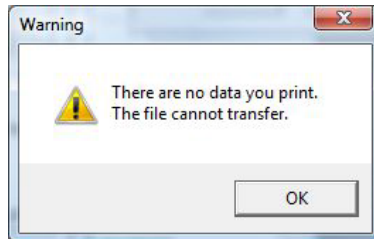

Click "OK" button, re-select the file, and select the operation from either "1" or "2".



- In PC control mode, the RS-232C command and input from the external I/O connector become invalid.
- When the mode is switched to PC control mode during the marking, the mode is switched after completing the marking.
- The test marking time displayed in the test marking may be slightly differed from the actual marking time.
In case of requiring the precise marking time, perform the marking using the external control (refer to Chapter 4), and measure the time using the marking start (trigger) signal and marking ending signal.
- When the counter is set, the test marking does not activate the count-up function.

3-10 Send/Read

This section describes the relative processing to the transfer and reading of the file.

1 "File" - "SEND/READ"

2 Click  .

The following screen is appeared by clicking either "1" or "2". (The following screen is the sample by clicking the operation "2".)

From the "Send/Read" button, the following four orations, "FILE TRANSMIT", "FILE LIST", "BACKUP", and "RESTORE" are selectable. Select the desired operation among four items (FILE TRANSMIT, FILE LIST, BACKUP, RESTORE).

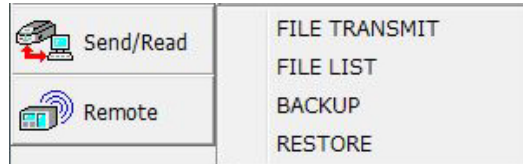

3-10-1 File Transmit

This item transfers the marking file to the head (laser marker body) for marking data in remote mode.



In case of marking in remote mode, it needs to transfer marking file to the head beforehand.

When selecting "FILE TRANSMIT", the "File Transmit" dialog box is appeared. In this dialog box, only the files that have already been set are displayed. They are displayed with their file Nos. (3 digits) and comments.

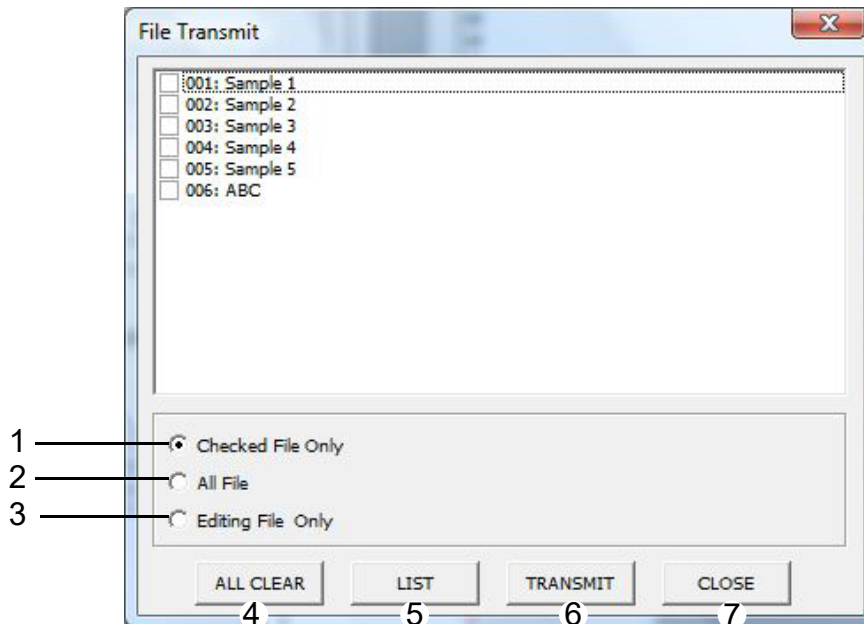

Item	Description
1. Checked File Only	Selects the marking file that is desired transferring from the files already set, and transfer only the checked file to the head.
2. All File	Transfers all the marking files already set to the head together.
3. Editing File Only	Transfers only the marking file displayed on the current screen to the head.
4. ALL CLEAR	Deletes all the files already transferred to the head.
5. LIST	Displays the list of the marking file in the head.
6. TRANSMIT	Starts transfer of the marking file.
7. CLOSE	Closes the dialog box.

If the file with the same file No. that is to be transferred is already existed in the head, the following dialog is appeared.

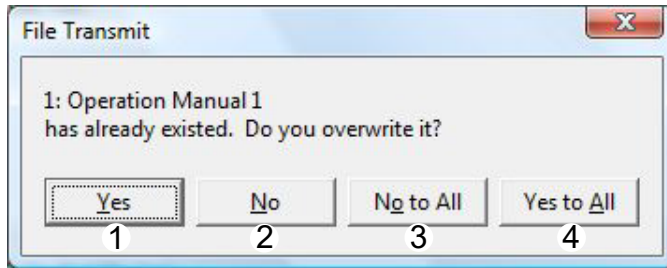

Item	Description
1. Yes	Overwrite the file
2. No	Not overwrite the file
3. No to All	Not overwrite all files
4. Yes to All	Overwrite all files

Click the "LIST" button to display the list of the files already transferred to the head, and check that the files have already been transferred.

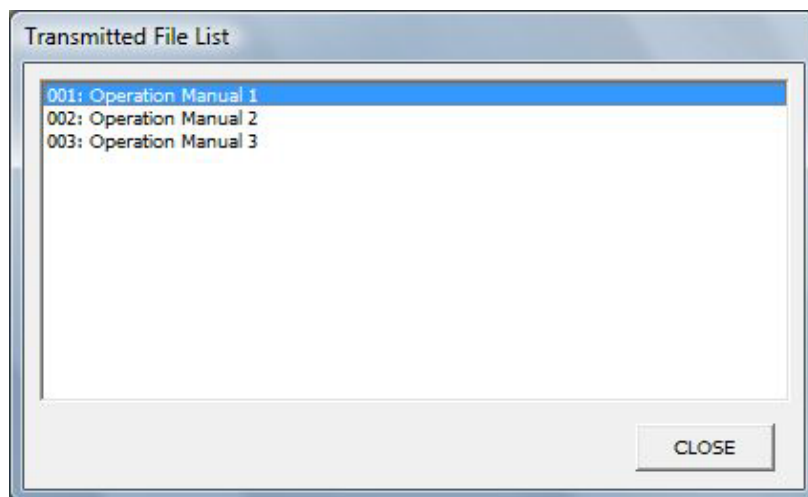

<File Size>

The size of the transferable marking file is limited.

If the total capacity of the marking file is large, it may be that all files cannot be transferred.

When trying to transfer the marking file with large data size, the warning message is displayed.



If the marking file cannot be transferred, reduce the file capacity by deleting the unnecessary marking files and retry transferring the file.



If total capacity of the marking file is large, it may be that all files cannot be transferred.

3-10-2 File List

The list of the marking files that have already been transferred to the head (laser marker body) can be confirmed.

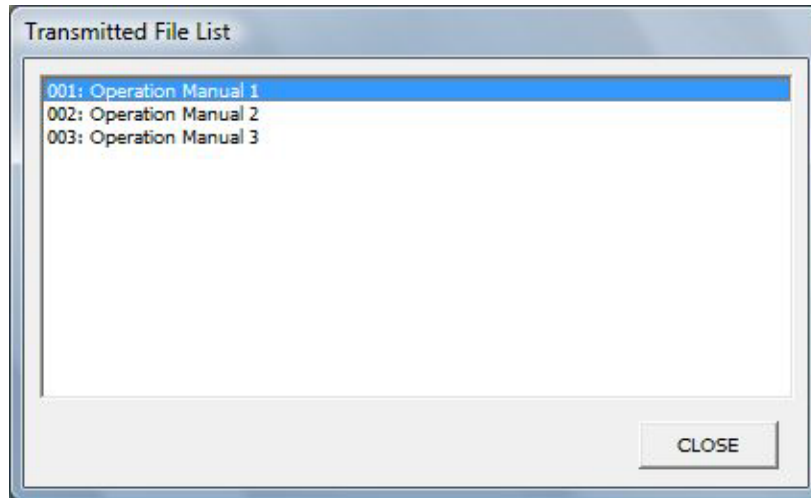

3-10-3 Backup

The marking files that have already been transferred to the laser marker is created the backup and stored in the PC. The extension for the backup file is “.LLB”.



CHECK

- The backup files of all files are read at a time.
- When the laser marker is not used for a significant period of time, be sure to save the back-up data of the laser marker files. During the unelectrified period, the battery for the back up will be out of charge and the data in the laser marker may be deleted.



REFERENCE

Though the “.LLB” file can be opened with the setting software of PC, it cannot be overwritten and registered. The LLB file can be stored as “.LLM” file by saving with other file name.

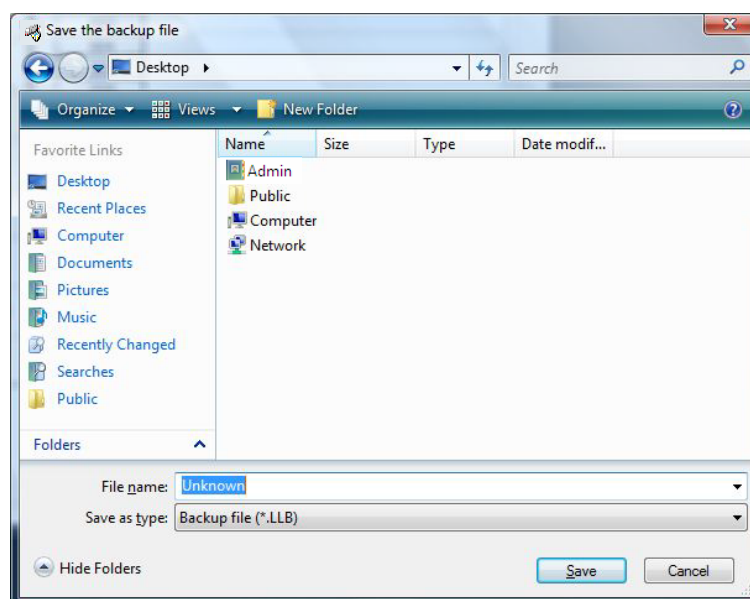

CHECK

Files are merely stored as “.LLB” files and do not affect the file under editing.

3-10-4 Restore

The “.LLB” file will be written back to the laser marker.



Since all the marking files in the laser marker are deleted by performing “RESTORE”, perform the backup as required.

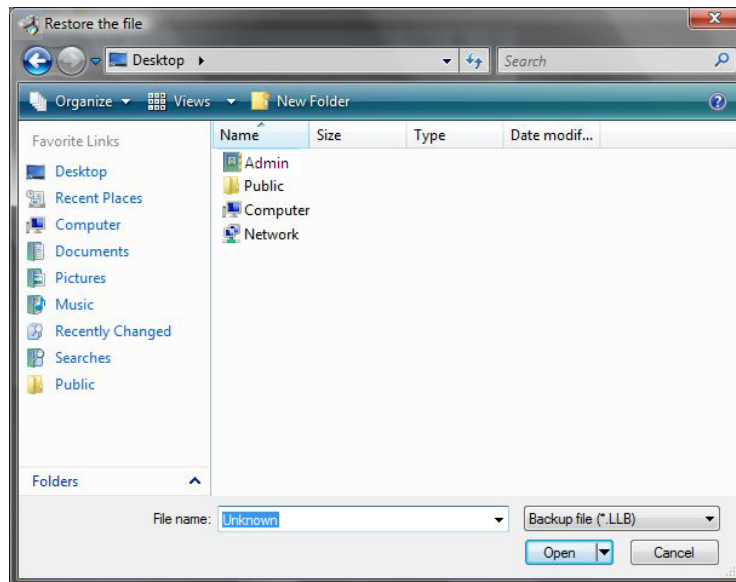

3-11 PC Control/Remote Mode

3-11-1 Remote Mode



This product has two types of the control mode, PC control mode and remote (external control). When turning on the power supply of this product, the remote mode is activated.

The remote mode refers to the marking mode controlling the marking from the external, similar to the control for the external I/O and control from RS-232C.

(1) Setting method of remote mode

The laser marker starts up in the remote mode for the following cases.

- 1 When turning ON the power
- 2 When shifting mode from PC control mode

(2) Shift from the PC control mode

Even if the product is started up with connecting the PC, it can be changed into the remote mode by the LP-310 setting software.

- 1 “Mode” - “REMOTE”

- 2 Click  .

By clicking either “1” or “2”, the dialog box for confirming whether to set the laser marker into remote mode or not is appeared.

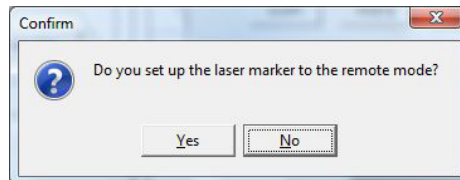

When selecting “Yes”, “Remote” button is changed to “PC Control” button.

When returning the mode of the laser marker to the PC control mode, click  PC Control button.

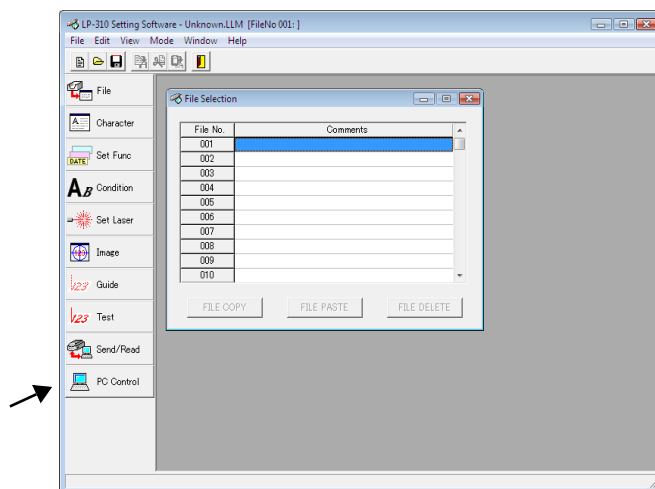

REFERENCE

When performing the marking in remote mode (external control), refer to “4 External Control” (P.155) for details.

3-11-2 PC Control Mode



This product has two types of the control mode, PC control mode and remote (external control). When turning on the power supply of this product, the remote mode is activated.

The PC control mode is the mode that the laser marker is controlled under PC control with the laser marker connected to the PC. The test marking, guide display, sending and reading of each setting, etc. are performed in PC control mode.

(1) Shift from the remote mode

Even if the laser marker is started with the PC connected, it can be changed into PC control mode by the LP-310 setting software.

1 “Mode” - “PC CONTROL”

2 Click  PC Control

By clicking either “1” or “2”, the dialog box for confirming whether to set the laser marker into PC control mode or not is appeared.

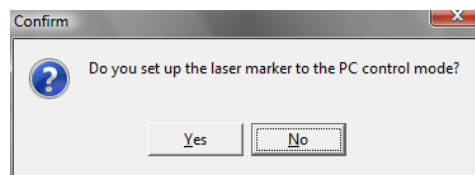

When selecting “Yes”, “PC Control” button is changed to “Remote” button.

When returning the mode of the laser marker to the PC control mode, click “Remote” button.

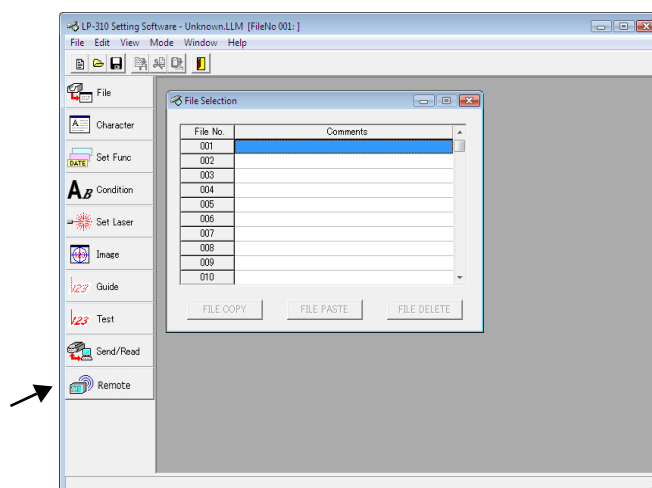

3-12 Switching Language between Japanese and English

The language display of the LP-310 setting software can be switched between Japanese and English easily. (This function is available only when this LP-310 setting software is installed into Japanese OS.)

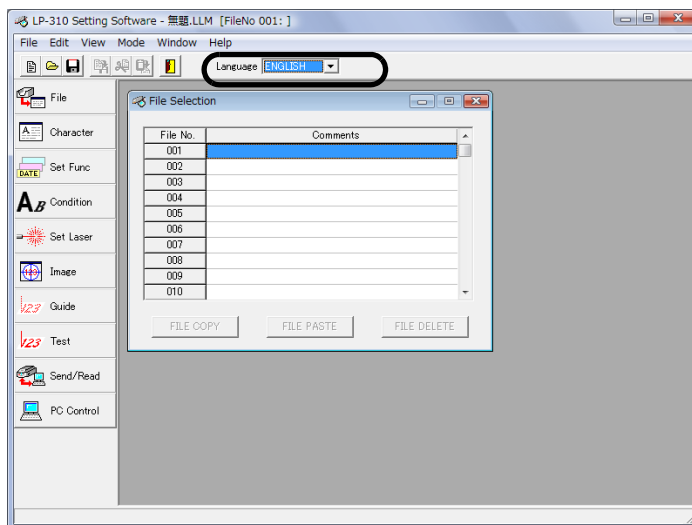
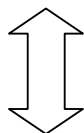
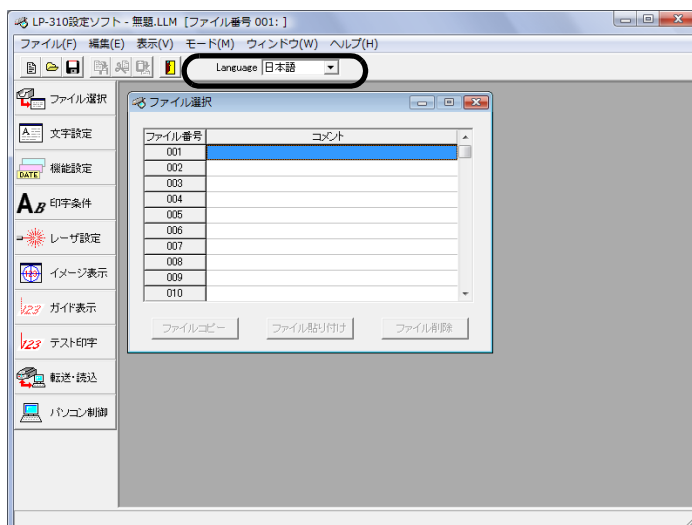

CHECK

The Japanese/English display switching function is the display switching of the LP-310 setting software.

The language can be switched between Japanese and English for Japanese Windows. However, this function is not available for English Windows.



CHECK

The errors related to Windows are displayed in Japanese (available only for Japanese OS).

3-13 Error History

The error history displays the dates, time, and details of the errors occurred in the past.

“File” - “ERROR”

The “Error History” dialog box is displayed.

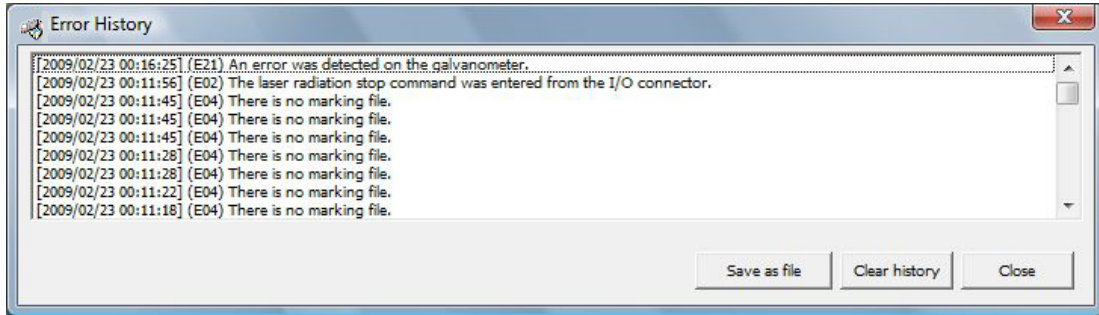

The dates, times, types, details, and error code of the error occurrence for the latest 255 times are displayed.

Item	Description
Save as file	The error history can be saved as file in the test format.
Clear history	Erases whole error history memorized in the head.
Close	Closes the “Error History” dialog box.

Details of Error History

Details of Error History	Code
Released interlock of the power supply box.	E01
Entered the laser radiation stop of the I/O connector.	E02
No marking file is existed.	E04
Released the interlock during marking.	E10
Entered laser radiation stop during marking.	E11
Occurred shutter operation during marking.	E12
Opened head cover.	E20
Occurred error on the galvanometer.	E21, 22
Occurred error on laser tube.	E23
Occurred error in marking file.	E25
Existed data out of the marking area.	E26
System error	E30 to E39



If the key switch is turned off during either excitation or laser radiation stop, the error related to the galvano may be recorded.

MEMO

3-14 Environmental Setting

Set the environments of the laser marker and PC.

3-14-1 Environmental Setting Related to Laser Marker

“File” - “ENVIRONMENT” - “Laser Marker”

When selecting the “Laser Marker” in “File”, the “Set Up Laser Marker” dialog box is appeared. On this screen, the following items, Date, Time, Era year, System Offset, and Port are set.

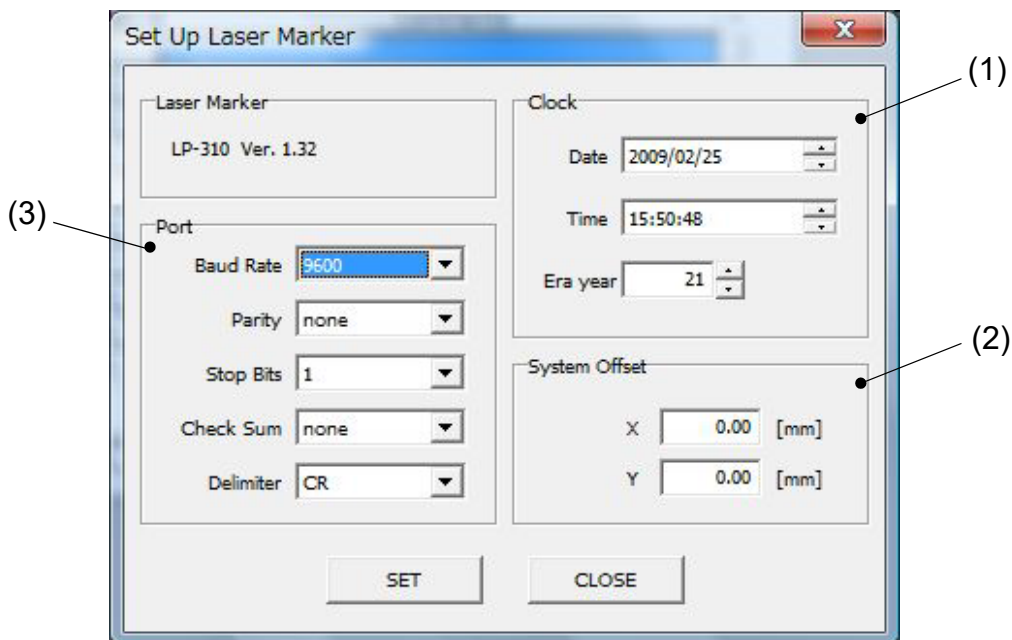

Click “SET” : The setting contents are reflected to this setting software and laser marker.

Click “CLOSE” : The change is ignored and the settings are returned to the original condition, and then the dialog box is closed.

(1) Clock

Set the date, time, and era year of the internal memory of the head are set.

Setting of date and time: Click the item to be changed, and change the value using up-down button.

Setting of era year : Click the era year and change the value using the keyboard. The settable era year is from 1 to 99. It is changeable using up-down button.



Adjust the clock setting of the laser marker to that of the PC.

The date and time set on the PC are applied only when displaying the image of the current date and time, etc. The date and time set on the PC are also applied to display the current date and so on as an image, and perform the test marking. Besides, the date and time set in the laser marker are applied to marking characters in the remote mode.

For the setting method of the date and time of PC, refer to the operation manual of the user's PC.



The following items, Date, Lot, and Expiration, are marked based on the internal clock integrated in the laser marker.

The internal clock might be deviated caused by the error of the internal parts or degree of the battery drain.

Therefore, be sure to check the time of the internal clock before the operation without fail.

(2) System Offset

Move the position of the whole file to the X or Y direction.

Setting Range : -2.00 to +2.00mm



Use this parameter to correct the error specific to the laser marker or the error at setting.

(3) Communication Port

Set the communication port for controlling the laser marker using the communication.

Item	Outline	Setting Range
Baud rate	Specifies the communication speed of the transmission/reception. This value indicates the information capacity sent/received in one second.	1200/2400/4800/9600/19200/38400 Select in the list box.
Parity	Specifies an error detection bit to each information delimited by a stop bit.	NA/Odd/Even Select in the list box.
Stop bit	Specifies the length of the delimiter signal of the information sent/received.	1 bit/2 bit Select in the list box.
Checksum	Specifies an error detection code to each information delimited by a delimiter.	NA/Available Select in the list box.
Delimiter	Specifies a symbol of rough separation on the information sent/received.	CR/CR+LF Select in the list box.



Refer to "4 External Control" (P.155) for details of the control of the laser marker using the communication.

3-14-2 Environmental Setting Related to PC

“File” - “ENVIRONMENT” - “PC...”

When selecting the “PC...” in “File”, the “Set Up PC” dialog box is appeared.
On this screen, the “Display” and “Font File” are set.

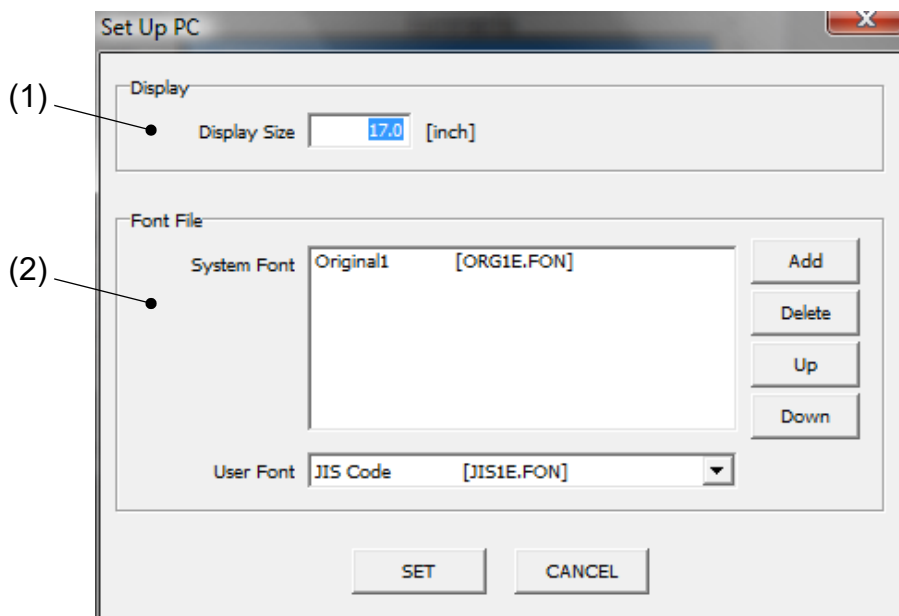

Click “SET”. : Reflects the setting contents.

Click “CANCEL”. : The change is ignored and the settings are returned to the original condition, and then the dialog box is closed.

(1) Display

Set the screen size of the user's PC. By inputting the screen size (unit: inch), the image display (edit area) is set to almost the same size of the marking area of the laser marker (when the magnification is set as “100”).



REFERENCE

Refer to “3-7 Image Display” (P.130) for details of the image display.

(2) Font File

Select the font file to be used for the character display by the LP-310 setting software and marking by the laser marker.

System Font : Font to be selected when setting the character condition and CAD condition.



Refer to “Character Code Table” (P.198) for details of the type of the system fonts.

The environmental setting cannot be finished if no font file is registered in the list of the system fonts. The following error is displayed.

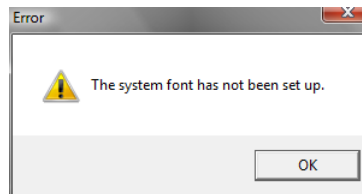

Click “OK” and register at least one system font.

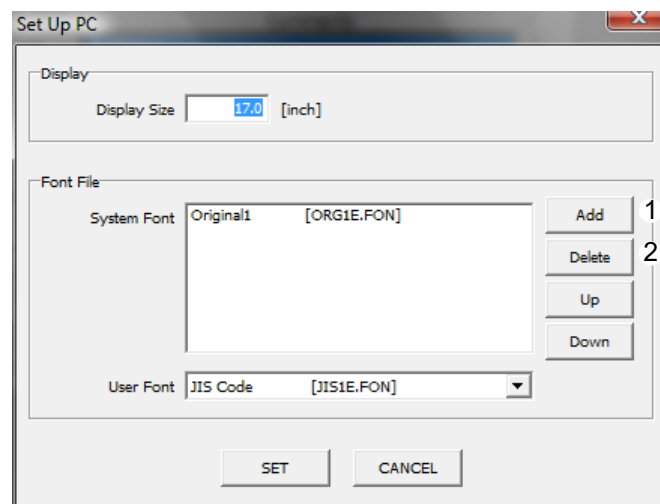

1 “Add” button : Adds the font file to the list of the system font.
Since the following dialog box is appeared, select the desired font file to be added.

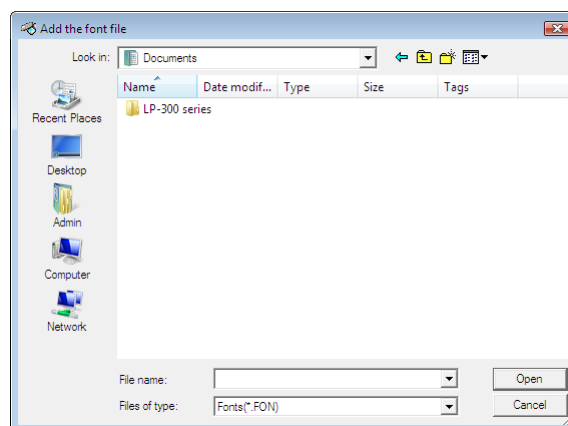

2 “Delete” button : Deletes the font file registered in the list of the system font from the list.
Select the desired font file to be deleted in the list, and click “Delete” button.

In case of deleting the font used for the file under editing from the list, the following dialog box is appeared.

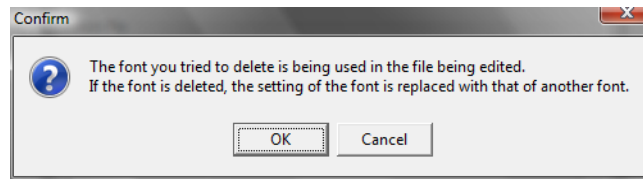

When deleting the font, click "OK", and when not deleting the font, click "Cancel".

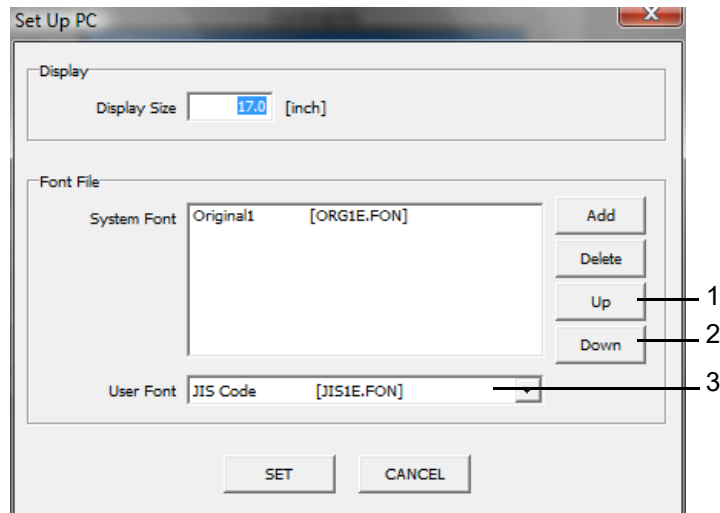

1 "Up" button : Raises the display order of the font in the list by one.

2 "Down" button : Lower the display order of the font in the list by one.



REFERENCE

The order displayed in the list is the order displayed when the font is set in the character condition and CAD condition.

3 User Font : Font files including the JIS level-1 Kanji and registration character except for symbols and alphanumeric characters.



REFERENCE

- Refer to "Character Code Table" (P.198) for details of the character type of the user fonts. Refer to "3-3-3 Input of Function Character" - "(6) Input registration character" (P.102) for details of the using method of the registration character.

4 External Control

4-1 Control Through I/O Connector	156
4-2 Control with RS-232C.....	166

4-1 Control Through I/O Connector

4-1-1 Before External Controlling Laser Marker Using I/O Connector

■ Flow

1. Turn ON the power supply of the laser marker.

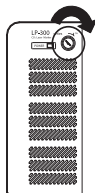

Turn the key switch of the power supply BOX clockwise.

2. Control the laser marker from the external.

Perform the external control following the contents of this chapter.



REFERENCE

When turning ON the key switch of the laser marker, the system is started. When the laser marker is ready for marking after the laser is excited, the READY output signal is output.



REFERENCE

When turning ON the key switch of the laser marker, the product becomes remote mode (external control mode).
When performing the guide display and test marking from the PC, release the remote mode following the indication displayed on the PC screen, and set the mode of the laser marker into PC control mode.

4-1-2 I/O Connector

■ Appearance of Connector

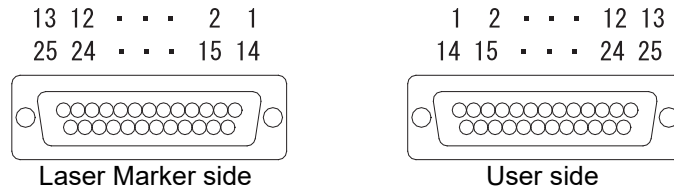

Laser Marker Side Connector Type : Female D-sub 25 pin

User Side Connector Type : Male D-sub 25 pin *

*As a user side connector, following items are attached to this product.

[Attached item] User Side Connector : HDBB-25P (Hirose Electric Co., Ltd.)

[Attached item] User Side Connector Cover : HDB-CTF (Hirose Electric Co., Ltd.)

■ Connecting Sample (In case of operating laser marker standalone)

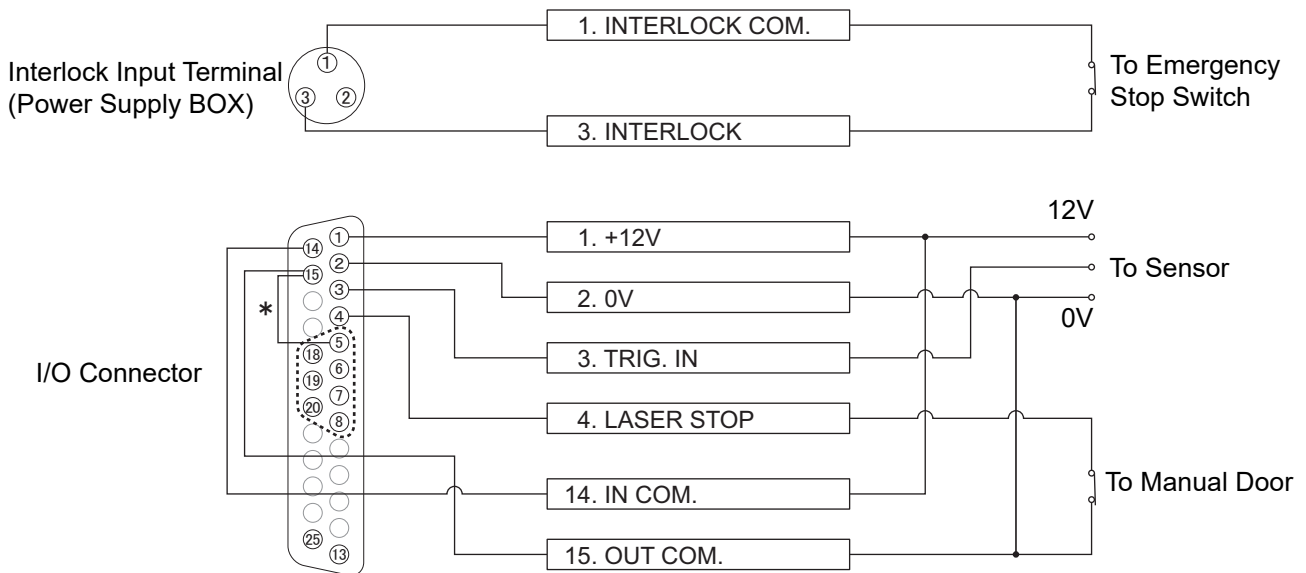

* Example when only the file No. 1 is used. To change the files, connect the pin No. 5 to 8 and 18 to 20 (D0 to D6) to the external control device.



- If not connecting the power supply (either internal power supply or external power supply) to the I/O connectors No. 14 **IN COM.** and No. 15 **OUT COM.**, the laser marker is not activated. For activating the laser marker, connect the power supply (either internal power supply or external power supply).
- When performing marking, connect the I/O connector No. 1 **INTERLOCK COM.** and No. 3 **INTERLOCK**. When setting the state between No. 1 and No. 3 into OPEN, the emergency stop is activated and the marking becomes invalid. Be sure to connect the interlock terminals on the connecting point. (24V 500mA)
- When performing marking, connect the I/O connectors No. 4 **LASER STOP** and No. 15 **OUT COM.**. When setting the state between No. 4 and No. 15 into OPEN, the laser radiation is activated, and the marking becomes invalid.
- When the interlock is short-circuited from OPEN, the head panel is displayed rotationally. While the head panel is displayed rotationally, the marking ready READY becomes OFF, and the laser marker does not perform marking.

■ Connecting Sample with External Devices

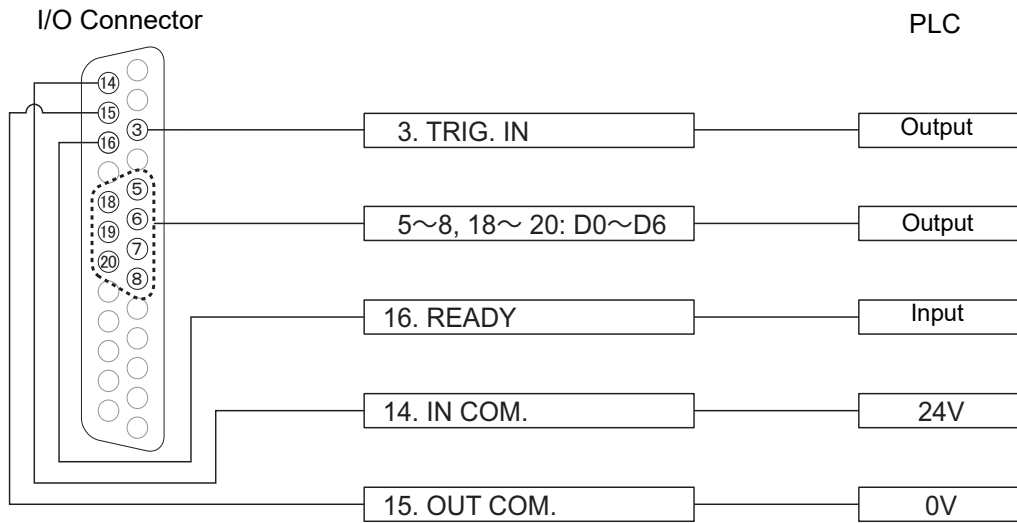

- When connecting to the external devices, the laser marker is not activated unless connecting the + (positive) side of the external power supply to the I/O connectors No. 14 **IN COM.** and connecting the ON of the external power supply to the I/O connector No. 15 **OUT COM.**. For operating the laser marker, connect the external power supply.
- When performing marking, connect the I/O connectors No. 4 **LASER STOP** and No. 15 **OUT COM.**.
When setting the state between No. 4 and No. 15 into OPEN, the laser radiation is activated, and the marking becomes invalid.
- When performing marking, connect the I/O connectors No. 1 **INTERLOCK COM.** and No. 3 **INTERLOCK**. When setting the state between No. 1 and No. 3 into OPEN, the emergency stop is activated and the marking becomes invalid.



4-1-3 Signal Name and Content of I/O Connector

Terminal No.	Display	Name	Description	
Input	14	IN COM.	Input common	Common for input
	3	TRIG. IN	Trigger input	Starts marking on the edge of the input ON. Input TRIG. IN with holding the input status of the file selection (D0 to D6).
	4	LASER STOP	Laser radiation stop input	When setting the states of both I/O connectors No. 4 LASER STOP and No. 15 OUT COM. to OPEN, the laser radiation is stopped. For marking, short-circuit the terminals No. 4 and No. 15.
	17	COUNTER RESET	Counter reset input	Sets this terminal ON for resetting the counter. Input COUNTER RESET with holding the input status of the file selection (D0 to D6).
	5	D0	File select input	These terminals are used for switching the file No. 1 to No. 120 saved in the head. Keep the input status of D0 to D6 while using the selected file.
	18	D1		
	6	D2		
	19	D3		
	7	D4		
20	D5			
8	D6			
Output	15	OUT COM.		
	16	READY	Marking ready output	When the marking is ready for starting (in TRIG.IN input receivable state), the output becomes ON.
	25	COUNTER END	Counter reset output	When the counter reaches to the ending value, the output comes ON.
	13	ALARM	Alarm output	When an alarm is occurred, the output becomes OFF. The content of the alarm is displayed with error code in the head display panel.
Power	1	+12V	Power supply for external device +12V	+12V DC power supply for external device. (100mA Max.)
	2	0V	Power supply for external device 0V	Ground for the power supply for external device (common to the inside)
RESERVE	9	Reserved	System reserve	Do not connect anything to the external devices.
	10			
	11			
	12			
	21			
	22			
	23			
24				

4-1-4 Input Rating and Input Circuit

The input rating and input circuit for I/O connector input are described in this section.

■ Input Rating

Item		I/O Connector Input
Input Form		Bidirectional photo coupler input (insulating input)
Input Operation	ON Voltage	Difference of voltages between input and input common: 8V or more
	OFF Voltage	Difference of voltages between input and input common: 4V or less
Rating Input Voltage		+12V DC to +24V DC +/-10%

■ Input Circuit

The following figure shows each input circuit. The input circuit is insulated by the bidirectional photo coupler. The input rating voltage is +12V DC to +24V DC.

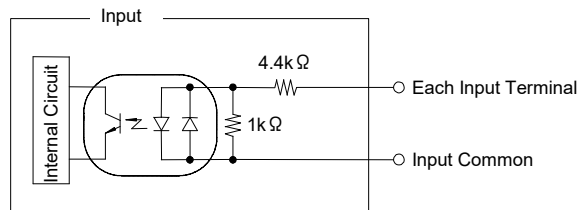

■ Input Connecting Sample

In case of inputting a signal by the current outflow method (Equivalent to NPN open collector output)	In case of inputting a signal by the current inflow method (Equivalent to PNP open collector output)
<p>Input common (14) - external power supply + Output common (15) - external power supply GND</p>	<p>Input common (14) - external power supply GND Output common (15) - external power supply +</p>



- The input and output circuits of this product are compatible with both NPN/PNP open collector output. However, mixing NPN and PNP is not allowed.
- If the open collector to be connected is NPN, use NPN to all the input and output circuits. If the open collector to be connected is PNP, use PNP to all the input and output circuits. Refer to the connecting sample shown above for wiring.
- Be sure to use the interlock function for this product for safety, and refer to the connecting samples of both input common and output common for wiring.

4-1-5 Output Rating and Output Circuit

The output rating and output circuit for I/O connector input are described in this section.

■ Output Rating

Item	I/O Connector Output
Output State	Photo MOS Relay (Insulating Output)
Short-circuit Protection Function	NA
Max. Output Current	50mA
Max. Impressed Voltage	+30V DC
Residual Voltage	+2.0V DC or less (at 50mA)

■ Output Circuit

The following figure shows each output circuit. The input circuit is insulated by the photo MOS relay. The max. impressed voltage is +30V DC, and max. sink/source current is 50mA.

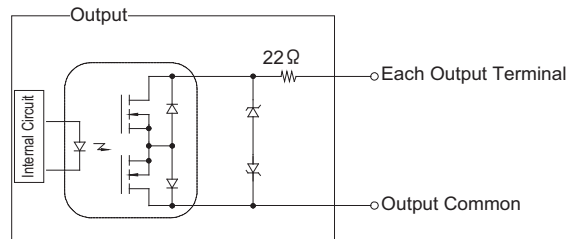

■ Output Connecting Sample

In case of outputting a signal by the current inflow method (Equivalent to NPN open collector output)	In case of outputting a signal by the current outflow method (Equivalent to PNP open collector output)
Input common (14) - external power supply + Output common (15) - external power supply GND	Input common (14) - external power supply GND Output common (15) - external power supply +



- The input and output circuits of this product are compatible with both NPN/PNP open collector output. However, mixing NPN and PNP is not allowed.
- If the open collector to be connected is NPN, use NPN to all the input and output circuits. If the open collector to be connected is PNP, use PNP to all the input and output circuits. Refer to the connecting sample shown above for wiring.
- Be sure to use the interlock function for this product for safety, and refer to the connecting samples of both input common and output common for wiring.

4-1-6 Input/Output Operation

■ I/O Connector Input Signal

Terminal No. 14: Input Common (IN COM.)

- This is the terminal for input common. Connect this terminal to the “+” (plus) side of the control power supply for NPN connection, and connect this terminal to the “-” (minus) side of the control power supply for PNP connection.

Terminal No. 3: Trigger Input (TRIG.IN)

- This is the terminal of marking start signal. When the marking ready output is ON, the marking is started on the edge of the trigger input ON signal.
Input TRIG. IN with holding the input status of the file selection (D0 to D6). (When the file No. changing command (FNO) is set by RS-232C, input of D0 to D6 is not required.)

Terminal No. 4: Laser Radiation Stop Input (LASER STOP)

- This is the input terminal for stopping laser radiation. It is connected to the switch of the manual door of the device.
When setting the state between the laser radiation stop input and terminal No. 15 OUT COM. into OPEN, the laser radiation is stopped.
(When setting this state into OPEN during marking, the laser pumping is stopped. When setting this state into OPEN during non-marking, the marking ready output becomes OFF.)

Terminal No. 17: Counter Reset Input (COUNTER RESET)

- This terminal sets the input to ON when resetting the counter.
Input COUNTER RESET with holding the input status of the file selection (D0 to D6).
(When the file No. changing command (FNO) is set by RS-232C, input of D0 to D6 is not required.)

Terminal No. 5, 6, 7, 8, 18, 19, 20: File Select Input (D0 to D6)

- These terminals select the file No. to be transferred into the head.
Specify the file No. (1 to 120) with D0 to D6. The file No. is specified with binary digit, and is selected by ON/OFF.
Keep the input status of D0 to D6 while using the selected file.

The “File No.” correspondence table is as follows.

File No.	File No. in binary form						
	D6	D5	D4	D3	D2	D1	D0
001	0	0	0	0	0	0	1
002	0	0	0	0	0	1	0
003	0	0	0	0	0	1	1
004	0	0	0	0	1	0	0
005	0	0	0	0	1	0	1
006	0	0	0	0	1	1	0
007	0	0	0	0	1	1	1
008	0	0	0	1	0	0	0
⋮	⋮						
118	1	1	1	0	1	1	0
119	1	1	1	0	1	1	1
120	1	1	1	1	0	0	0

* The selectable file Nos. are from 1 to 120.

(E.g.) In case of specifying the marking file No. 50 transferred into the head:

- Since the “50” is represented as “0110010” with binary digit, set the value of the lowest digit as “D0”, and select ON/OFF as follows.

Terminal (Terminal No.)	Binary Digit	Input
D0 (No. 5)	0	OFF
D1 (No. 18)	1	ON
D2 (No. 6)	0	OFF
D3 (No. 19)	0	OFF
D4 (No. 7)	1	ON
D5 (No. 20)	1	ON
D6 (No. 8)	0	OFF



- Keep the input status of D0 to D6 while using the selected file. TRIG. IN and COUNTER RESET are executed to the selecting file number by D0 to D6 input.
- Once the file No. changing command (FNO) is set by RS-232C, changing files by D0 to D6 input of I/O connector is not available.

■ I/O Connector Output Signal

Terminal No. 15: Output Common (OUT COM.)

- This is the terminal for output common. Connect this terminal to the “+” (plus) side of the control power supply for NPN connection, and connect this terminal to the “-” (minus) side of the control power supply for PNP connection.

Terminal No. 16: Marking Ready Output (READY)

- This is the terminal for marking ready output. When the marking is ready for starting (with TRIG.IN input receivable state), the output becomes ON.

Terminal No. 25: Counter Ending Output (COUNTER END)

- When the counter reaches to the ending value, the output comes ON. The counter ending output continues until the next marking start input is entered.



- The counter is not activated for the test marking.
- The counter ending output continues until the next marking start input is entered.

Terminal No. 13: Alarm Output (ALARM)

- When an alarm is occurred, the output becomes OFF. The laser radiation stops when this alarm output becomes ON.
The content of the alarm is displayed with error code in the head display panel.

■ I/O Connector Power Supply

Terminal No. 1: Power Supply for External Device +12V (+12V)

- This is the power supply for external device. The max. output current is 100mA.

Terminal No. 2: Power Supply for External Device 0V (0V)

- This is the 0V power supply for external device.

4-1-7 Timing Chart

Basic I/O

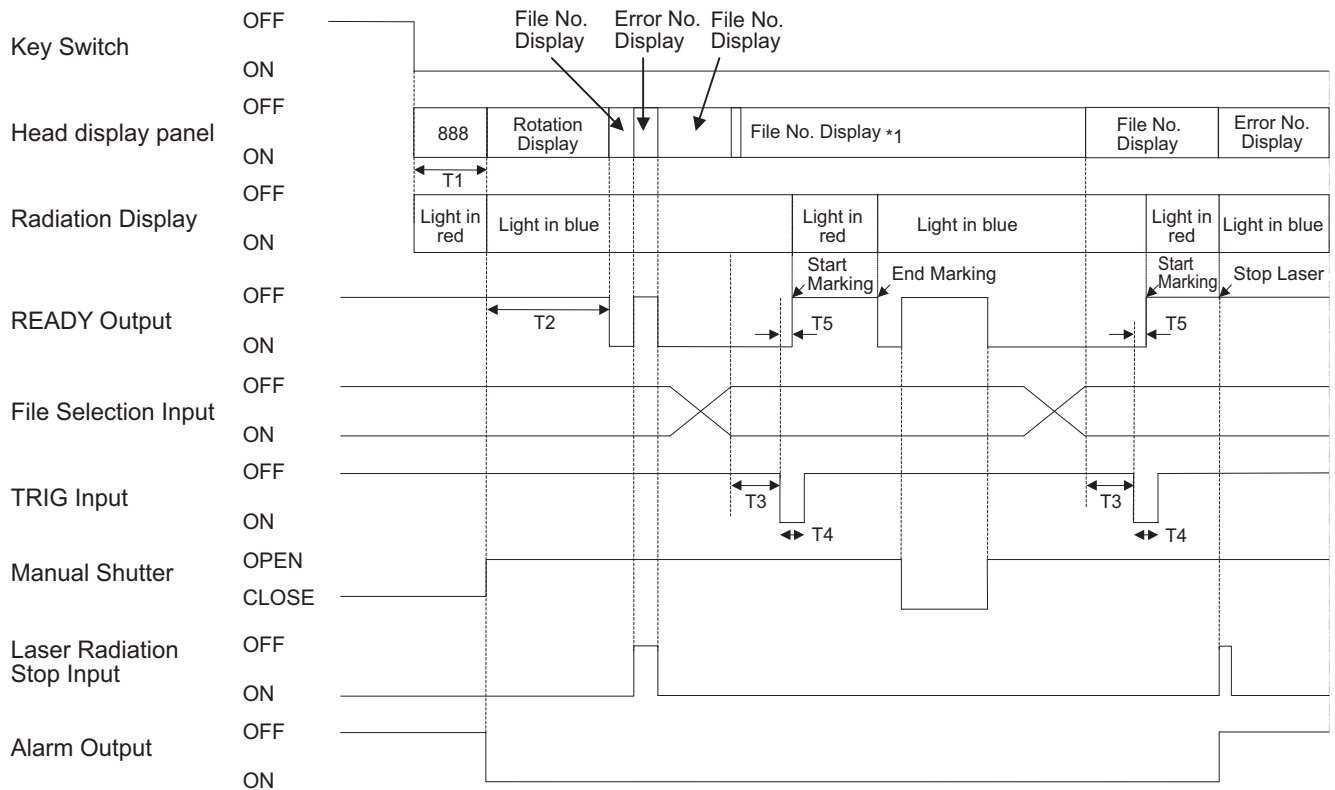

*1: For the file selection input in I/O, if a value of 1 to 120 is selected, the selected file No. is displayed.
If a value other than 1 to 120 is selected, '---' is displayed.



- Input TRIG. IN with holding the input status of the file selection (D0 to D6). (When the file No. changing command (FNO) is set by RS-232C, input of D0 to D6 is not required.)
- To reset the alarm status, reboot the laser marker by turning the key switch.

Item	Time	Remarks
T1	Approx. 0.5 sec.	System check time
T2	Approx. 15 sec.	Disables to perform marking after approx. 15 seconds from the start of the laser pump.
T3	1ms or more	Set the marking trigger to ON when passing 1ms or more after switching the file.
T4	10ms or more	Keep ON state for 10ms or more.
T5	within 5ms	Time from inputting the trigger to the start of the actual marking.

■ Operation Related to Counter

In case of the counter initial value of the counter is 1 with counter step 1:

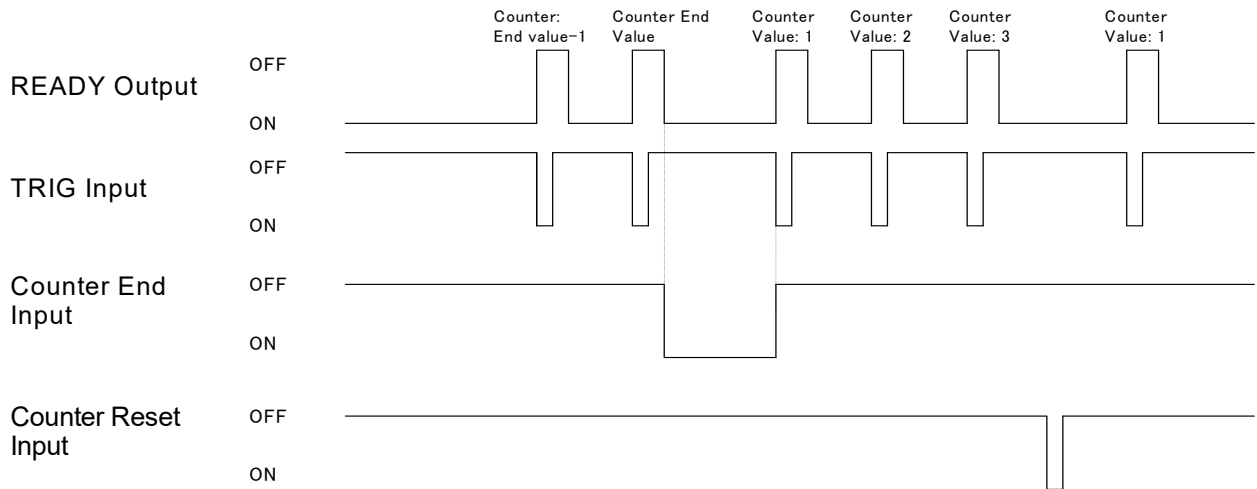

- Input COUNTER RESET with holding the input status of the file selection (D0 to D6).
(When the file No. changing command (FNO) is set by RS-232C, input of D0 to D6 is not required.)

4-2-1 Before External Controlling Laser Marker Using RS-232C

■ Flow

1. Accommodate the setting of the laser marker and that of the communication condition of the connected external device.

Refer to "4-2-4 Setting of Communication Condition" (P.168) for details.

2. Turn ON the power supply of the external device.

3. Turn the key switch of the power supply BOX of the laser marker.

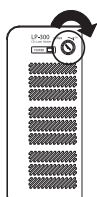

Turn the key switch of the power supply BOX clockwise.

4. Control the laser marker by external device.

Control the laser marker by the external device following the content of this chapter.



REFERENCE

When turning the key switch of the laser marker, the system is started. When the laser marker is ready for marking after the laser is excited, the READY output signal is output.



REFERENCE

When turning the key switch of the laser marker, the product becomes remote mode (external control mode). When performing the guide display and test marking from the PC, release the remote mode following the indication displayed on the PC screen, and set the mode of the laser marker into PC control mode.

4-2-2 RS-232C Connector

In case of controlling the laser marker with the serial communication using the RS-232C, the “RS-232C connector” is used.

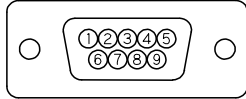

Laser Marker side

No	Signal Name	Function
1	Reserved	System reserved
2	RXD(RD)	Received data
3	TXD(SD)	Sent data
4	Reserved	System reserved
5	GND(SG)	Signal ground
6	Reserved	System reserved
7	Reserved	System reserved
8	Reserved	System reserved
9	Reserved	System reserved

Laser Marker Side Connector Type : Male D-sub 9 pin (No. 4-40UNC-inch screw, female)
 User Side Connector Type : Female D-sub 9 pin (No. 4-40UNC-inch screw, male)

4-2-3 Specification for RS-232C

Connector	D-SUB 9 pin, male
Synchronization Method	Asynchronous
Communication Method	Full duplex communication method
Stop Bit	1 bit/2 bits
Data Bits	8 bits fixed
Baud Rate	1200/2400/4800/9600/19200/38400
Parity	None/even/odd
Check Sum	NA/available
Delimiter	CR + LF/CR
Flow Control	None (three-wire method)
Reception Timer	Reception timeout monitoring available (10 seconds for reception)



REFERENCE

Refer to “3-14-1 Environmental Setting Related to Laser Marker” (P.150) for details of the setting of the communication condition.

4-2-4 Setting of Communication Condition

When selecting “File” - “ENVIRONMENT” - “Laser Marker”, the dialog box “Set Up Laser Marker” is appeared. On this dialog box, accommodate the condition of the “communication port” for laser marker setting with the external device and the communication condition.

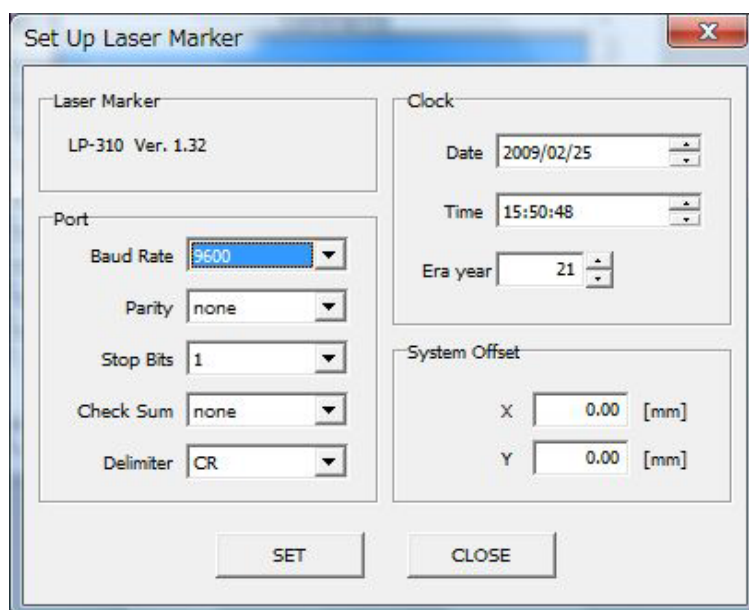

Item	Outline	Setting Range
Baud Rate	Specifies the communication speed of the transmission/reception. This value indicates the information capacity sent/received in one second.	1200/2400/4800/9600/19200/38400 Select in the list box.
Parity	Specifies an error detection bit to each information delimited by a stop bit.	NA/Odd/Even Select in the list box.
Stop Bits	Specifies the length of the delimiter signal of the information sent/received.	1 bit/2 bit Select in the list box.
Check Sum	Specifies an error detection code to each information delimited by a delimiter.	NA/Available Select in the list box.
Delimiter	Specifies a symbol of rough separation on the information sent/received.	CR/CR+LF Select in the list box.

4-2-5 Connecting Sample of External Control Device

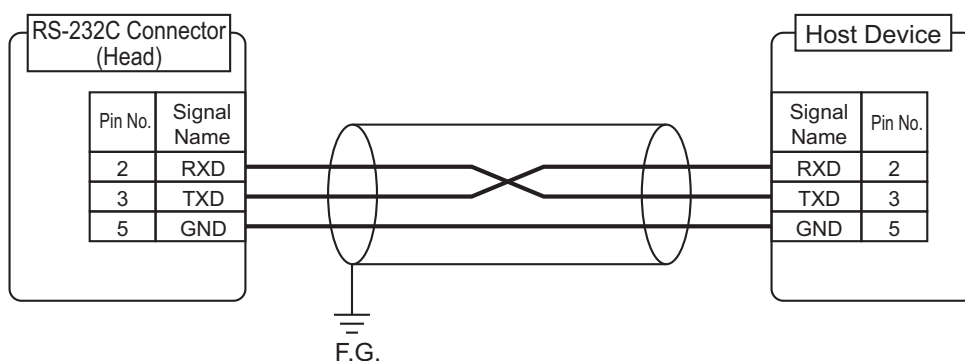

- This product is operated using the three wires of RD (RXD), SD (TXD), and SG (GND). However, since loop back may be necessary on the external device side, refer to the operation manual of the external device to connect this product.
- If connecting the PC for control and laser marker, use the commercial cross cable.

4-2-6 Check Connection

Check whether the laser marker is connected to the external control device properly or not in accordance with the following procedures.

■ Flow

1. Accommodate the setting of the laser marker and that of the communication condition of the connected external device.

Refer to "4-2-4 Setting of Communication Condition" (P.168) for details.

2. Turn ON the power supply of the external device.

3. Turn ON the power supply of the laser marker.

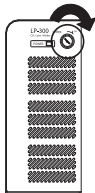

Turn the key switch of the power supply BOX clockwise.
The laser marker starts-up in the remote mode.

*Open the manual shutter.

4. Transfer "File No. Change (Code: FNO)" command.

Start Code (Fixed) STX	Command Code File No. Change FNO	Subcommand Data Setting or Operation S	Data File No. 001	Check sum (Refer to "*" below)	Delimiter Data End Recognition Code CR + LF
02	46 4E 4F	53	30 30 31	43 39	0D 0A (HEX)

5. Check the response from the laser marker.

If the connection is performed properly, the laser marker sends back the response data of either ACK or NAK.

ACK	00	Check sum	Delimiter	
06	30 30	36 36	0D 0A	(HEX) "Response Data" (P.174)
NAK	Response code	Check sum	Delimiter	
15			0D 0A	(HEX)

*Check sum

With this check sum, add the character from the start code to the end of the data by converting the data into hexadecimal (representing into binary value) using the ASCII code table.

$$02_{(\text{HEX})} + 46_{(\text{HEX})} + 4E_{(\text{HEX})} + 4F_{(\text{HEX})} + 53_{(\text{HEX})} + 30_{(\text{HEX})} + 30_{(\text{HEX})} + 31_{(\text{HEX})} = 1C9_{(\text{HEX})}$$

↓
Character at lower 2 digits (lower 1 byte) is C9_(HEX)

↓
When converting this data into 2 characters, it becomes 43 39_(HEX).

4-2-7 Sample of Control

The following chart shows the sample of the control flow chart for controlling the laser marker using the RS-232C.

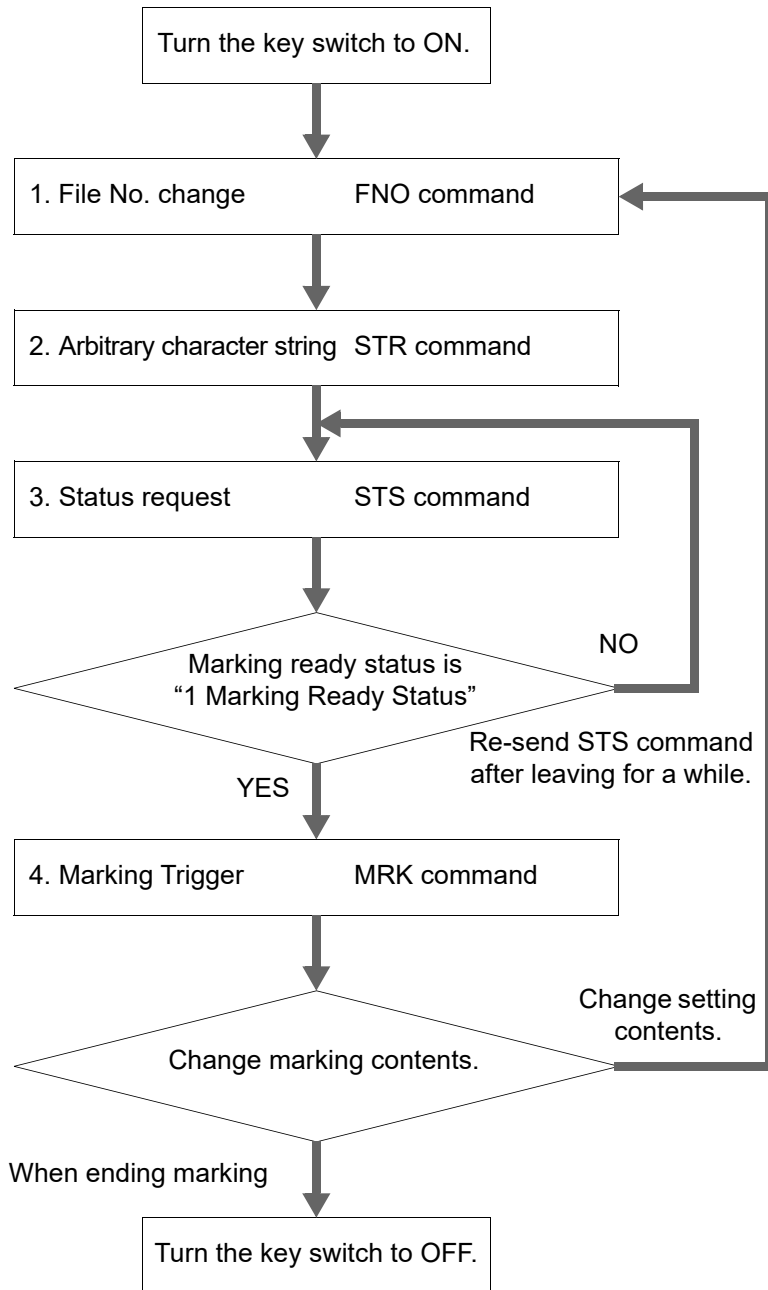

■ Control Sample 1: In case of marking data changing the character content

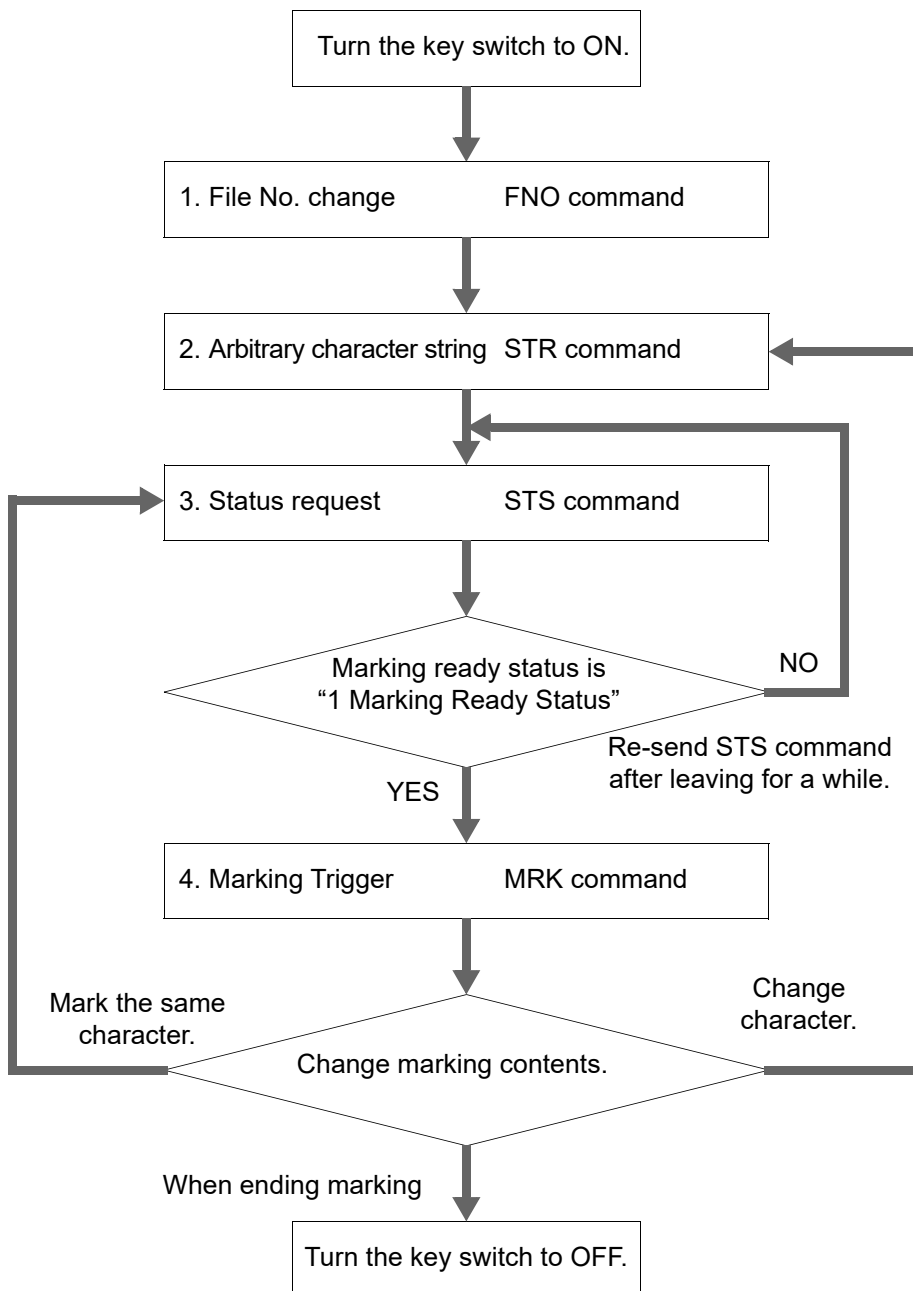

■ Control Sample 2: In case of marking data switching file

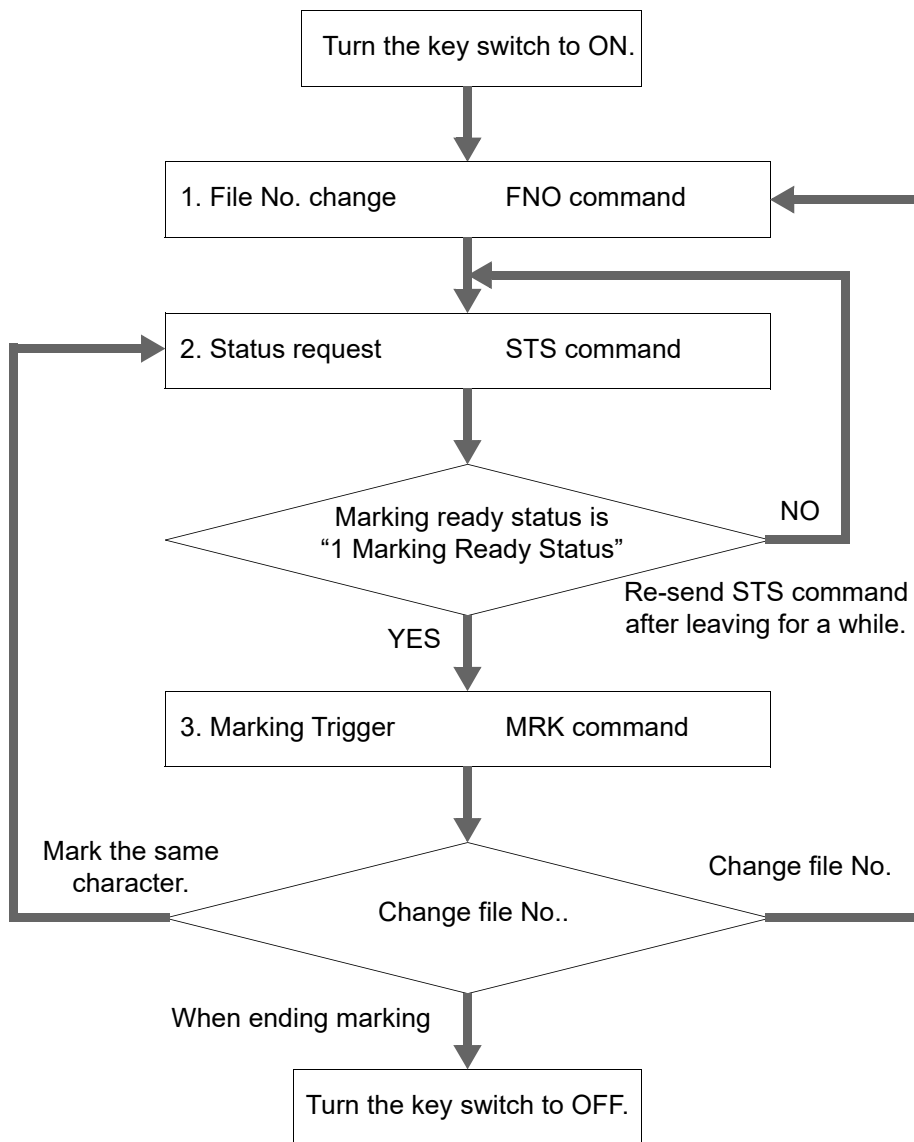

4-2-8 Communication Data Format

In case of controlling the laser marker from the external device, basically the characters to be used for the communication use the ASCII code, and part of the characters are shift JIS code.

The character enclosed with the quotation “(’)” expresses the ASCII code.

In case of using the shift JIS code, refer to explanation for details and follow it.

■ Command Data

The command refers to the command to be sent to the laser marker from the external device. With the command data, it is possible to create command data using the specified format, to operate the laser marker by remote control, and to perform the specified marking procedures.

● Command Data Format

Start Code	Command	Subcommand	Data	Check sum	Delimiter
1 Character	3 characters	1 character	Variable length	2 characters	2 char./1 char.

Top ←

→ End

Description of Each Code

Name	Description
Start Code	Code for recognizing the head of the data. Fixed with STX (code: 02 _(HEX))
Command	Specifies command with 3 characters. (“4-2-10 Communication Command and Function” (P.180))
Subcommand	Specification of the “Set/Read” to be added to the command subsidiary. Specify operation with either character below: ‘S’ ... Setting or operation of data (Set) ‘R’ ... Reading of setting data (Read) (Note) There are some commands that disables to be specified with either ‘S’ or ‘R’.
Data	Data to be specified for each command. The content of the specification is differed depending on the command. (“4-2-10 Communication Command and Function” (P.180))
Check Sum	Data that the lowest 1 byte is expressed with 2 characters of ASCII code by adding the codes from start code until data in binary E.g.: Command•••‘ABC’, Subcommand•••‘S’, Data•••‘000’ $02_{(HEX)}+41_{(HEX)}+42_{(HEX)}+43_{(HEX)}+53_{(HEX)}+30_{(HEX)}+30_{(HEX)}+30_{(HEX)}=1AB_{(HEX)}$ When converting the lowest 1 byte AB _(HEX) of the 1AB _(HEX) into 2 characters, it becomes “41 _(HEX) +42 _(HEX) ”. The valid/invalid of the checksum is available to be set in the environmental setting related to the laser marker of the LP-310 setting software.
Delimiter	Code for recognizing the end of the data CR+LF ••• 0D _(HEX) and 0A _(HEX) CR •••••• 0D _(HEX)



- The laser marker deals the data from the start code (STX) to the delimiter (CR or CR+LF) as the command data. In case of existing the unnecessary data before start code or after delimiter, that character is ignored (it just is ignored, not sent back the abnormal response data).

■ Response Data

There are three types of the response data the laser marker sends back against the command data sent from the external device as follows.

1. Normal reception response data

The start code of this response data is started with "ACK". If the command is normal, or if the command processing is ended normally, this response data is sent back.

2. Abnormal reception response data

The start code of this response data is started with "NAK". If the command is abnormal, or if the command processing is ended abnormally, this response data is sent back.

3. Readout data

The start code of this data is started with "STX". If the command is normal and the subcommand is expressed with 'R', this response data is sent back.

Normal Reception Response Data Format

Start Code 1 Character	Response Code 2 characters	Check sum 2 characters	Delimiter 2 char./1 char.
---------------------------	-------------------------------	---------------------------	------------------------------

Top ←

→End

Description of Each Code

Name	Description
Start Code	Fixed with "ACK" (code: 06(HEX)). This is the code for identifying the head of the data and recognizing the data is normal receiving response data.
Response Code	Sends back 2 characters '00' for ACK.
Check Sum	Data that the lowest 1 byte is expressed with 2 characters of ASCII code by adding the codes from start code until data in binary E.g.: 06(HEX)+30(HEX)+30(HEX)=66(HEX) When converting '66(HEX)' into 2 characters, it becomes "36(HEX)+36(HEX)". The valid/invalid of the checksum is available to be set in the environmental setting related to the laser marker of the LP-310 setting software.
Delimiter	Code for recognizing the end of the data CR+LF ••• 0D(HEX) and 0A(HEX) CR •••••••• 0D(HEX)

Abnormal Reception Response Data Format

Start Code 1 Character	Response Code 2 characters	Check sum 2 characters	Delimiter 2 char./1 char.
---------------------------	-------------------------------	---------------------------	------------------------------

Top ←

→End

Description of Each Code

Name	Description
Start Code	Fixed with "NAK" (code: 15 _(HEX)). This is the code for identifying the head of the data and recognizing the data is normal receiving response data.
Response Code	Sends back the content of the abnormality with 2 digits 01...Received improper STX 02...Received improper delimiter, or occurred timeout 03...Command that is impossible to be received because the laser marker is under marking. 04...No corresponding command is existed. 05...Improper check sum 06...Improper length of the receiving data 07...System reserved 08...Improper subcommand 09...Improper receiving data 10...Occurred alarm 11...No specified file is existed. 99...Others
Check Sum	Data that the lowest 1 byte is expressed with 2 characters of ASCII code by adding the codes from start code until data in binary E.g.: Response Code... '20' $15_{(HEX)} + 32_{(HEX)} + 30_{(HEX)} = 77_{(HEX)}$ When converting '77 _(HEX) ' into 2 characters, it becomes "37 _(HEX) +37 _(HEX) ". The valid/invalid of the checksum is available to be set in the environmental setting related to the laser marker of the LP-310 setting software.
Delimiter	Code for recognizing the end of the data CR+LF ... 0D _(HEX) and 0A _(HEX) CR 0D _(HEX)

Readout Response Data Format

Start Code 1 Character	Command 3 characters	Subcommand 1 character	Data Variable length	Check sum 2 characters	Delimiter 2 char./1 char.
---------------------------	-------------------------	---------------------------	-------------------------	---------------------------	------------------------------

Top ←

→End

Description of Each Command

Name	Description
Start Code	Fixed with "STX" (code: 02(HEX)). This is the code for identifying the head of the data and recognizing the data is normal receiving response data.
Command	Specifies readout with 3 characters.
Subcommand	Fixed with 'A'. Expresses "Answer" for the readout specification.
Data	Data that has been readout. The data length and the format are differed for each command. ("4-2-10 Communication Command and Function" (P.180))
Check Sum	Data that the lowest 1 byte is expressed with 2 characters of ASCII code by adding the codes from start code until data in binary E.g.: Command•••'ABC', Subcommand••• 'A', Data••• '000' $02(\text{HEX})+41(\text{HEX})+42(\text{HEX})+43(\text{HEX})+41(\text{HEX})+30(\text{HEX})+30(\text{HEX})+30(\text{HEX})=199(\text{HEX})$ When converting the lowest 1 byte AB(HEX) of the 199(HEX) into 2 characters, it becomes "39(HEX)+39(HEX)". The valid/invalid of the checksum is available to be set in the environmental setting related to the laser marker of the LP-310 setting software.
Delimiter	Code for recognizing the end of the data CR+LF ••• 0D(HEX) and 0A(HEX) CR •••••• 0D(HEX)

4-2-9 Communication Sequence

This section describes sequence of the transmission and reception for either command or response data between the external device and laser marker

Note that the sequence of the transmission and reception is activated differently for interruption prohibited state and interruption allowed state.

■ Normal Transmission/Reception Sequence for Data Setting and Operation Direction

The following figure shows the sequence when the command and setting transmitted from the external device to the laser marker is correct.

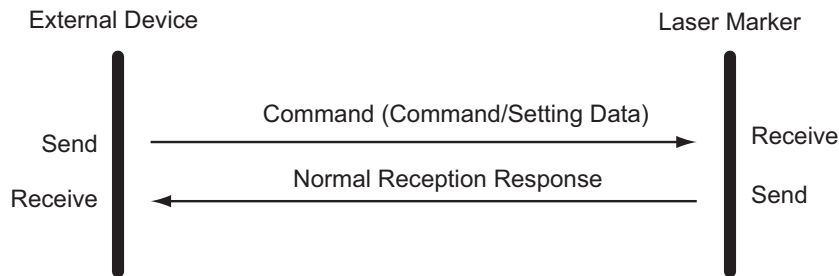

■ Normal Sequence of Setting Data Readout

The following figure shows the sequence when the readout of the setting data (subcommand: 'R') transmitted from the external device to the laser marker is correct.

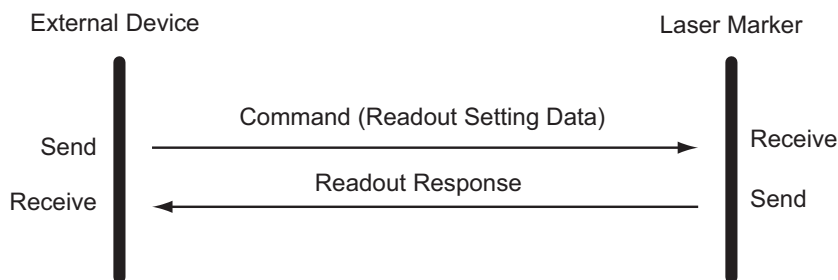

- In case of sending command from the external device continuously, be sure to check the reception of the response from the laser marker, and send the command.

■ Transmission/Reception Sequence for Abnormal Command

The following figure shows the sequence when the command sent to laser marker from the external device is abnormal.

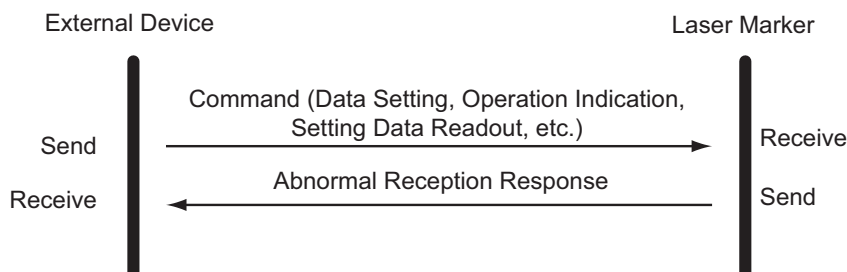

■ Reception Timeout

The laser marker performs the reception timeout check (monitoring the time for completely receiving data ranging from the top to the bottom of the command while a command is received) when receiving the command sent from the external device.

The time of the reception timeout is 10 seconds. If the command is not received completely from the top to the bottom of the data within this time, it is judged that some trouble has occurred either on the external device or on the transmission route, and all transmission/reception processing is stopped completely.

When the reception timeout occurs, the data being received is discarded.

■ Transmission/Reception Sequence with Transmission Prohibition and Permission of Marking State

The communication sequence with the laser marker is the basis “to send a response to the command from the external device”.

However, by sending a marking state transmission permission command (for detail of the command, refer to “4-2-10 Communication Command and Function” (P.180)) to set the permission of the transmission, the timing of the marking operation of the laser marker (end of marking, or a warning occurs during marking operation according to the setting of the marking conditions) can be known from the laser marker.

- Communication sequence when “transmission prohibition” is set by the marking state transmission permission command

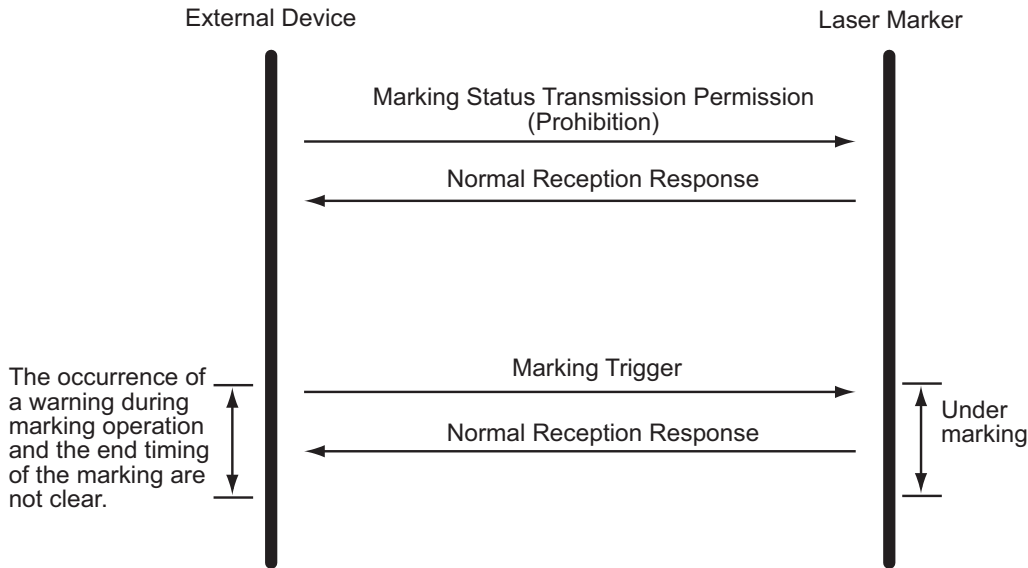

- Communication sequence when “transmission permission” is set by the marking state transmission permission command

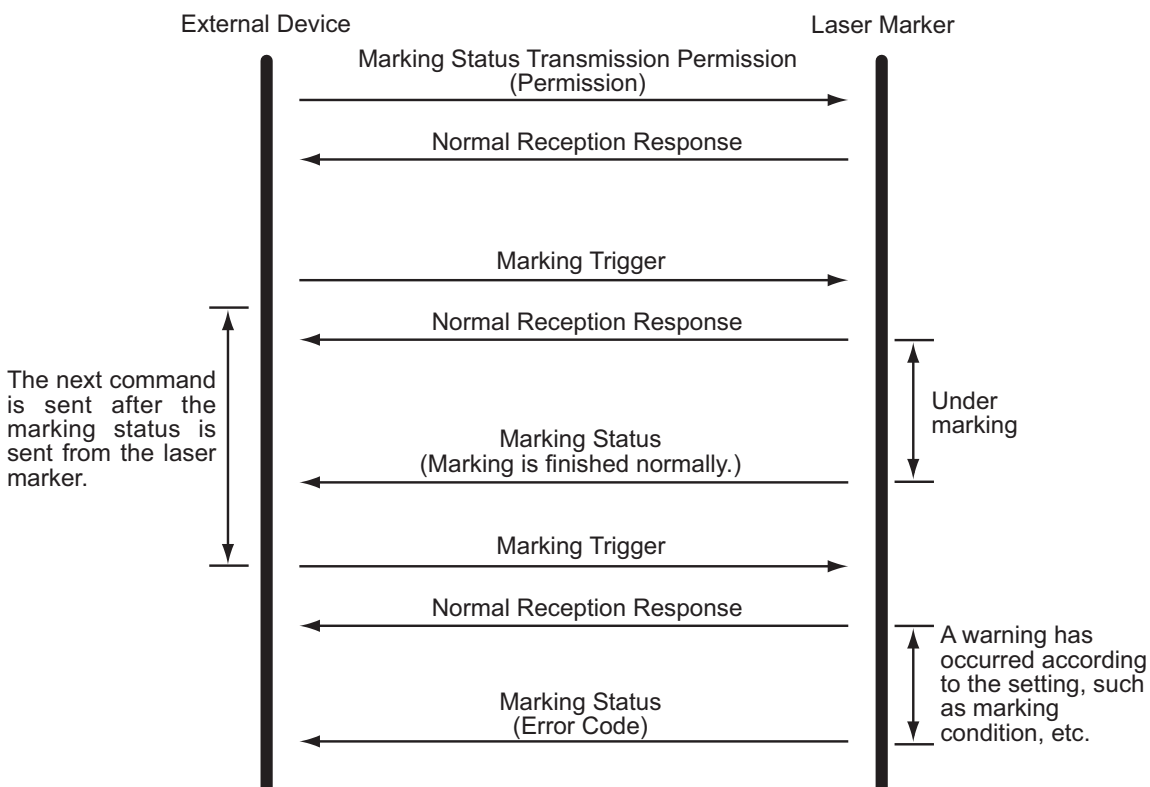

■ Marking Operation and Command Transfer

(1) When transferring command to laser marker during marking:

Only the state request command is acceptable during marking.

If a command other than the state request is transferred, the abnormal response telegram (error code "03") is returned.

(2) When transferring command to laser marker while an alarm is occurred:

Only the state request command is acceptable while an alarm is occurred.

If a command other than the state request is transferred, the abnormal response telegram (error code "10") is returned.

No alarm can be released by communication control. Refer to "5-1 Troubleshooting" (P.187) and "5-2 Measures for Indicated Error" (P.188) for detail of measures for alarm.

If the marking status transmission is permitted, a marking state is returned when a marking operation is finished or an error is occurred.

■ Using Communication Control and I/O Connector (25-pin Connector) Together

When the "file number change" command (FNO) is not accepted, the control using I/O connector is available. Only the following items, "marking trigger" (MRK), "status request" (STS), "optional character string" (STR), and "marking status transmission permission" (MST) are available for controlling through RS-232C.

In case of receiving "file number change" command (FNO):

The "file selection input (D0 to D6)" of I/O connector is ignored.

All commands can be controlled through RS-232C.

After turning OFF the power supply, the control is returned to the control from the I/O connector.

For using both communication control and I/O connector (25-pin connector), pay attention to the input timing.

In addition, as for the output signal, perform the same output using the communication control as the output using the external control.

4-2-10 Communication Command and Function

■ List of Commands

Name	Code	Function Outline	Page
1. File number change	FNO	Switches the file number to the specified file number.	P. 180
2. Arbitrary character string	STR	Sets the arbitrary character string in ASCII code.	P. 182
3. Counter current value	CNT	Sets the current value of the counter.	P. 183
4. Counter reset	CTR	Resets the counter.	P. 183
5. Status request	STS	Calls out the operation status of the laser marker.	P. 184
6. Marking trigger	MRK	Controls the marking.	P. 184
7. Marking status transmission permission	MST	Sets the permission/prohibition of the sending response when marking is finished.	P. 185



After receiving the "File number change" (FNO), each command is to be executed for the file number selected with "File number change" (FNO) command.



After sending the "File number change" (FNO), "Counter current value" (CNT) and "Counter reset" (CTR) are acceptable.

■ Details of Commands

1. File number change (code: FNO)

(1) File number change

This command changes the file number to the specified file number.

When receiving the file number change command from the RS-232C, only RS-232C is effective for the following file number switching. Besides, after turning OFF the power supply, the control is returned to the control from the I/O connector.

STX	FNO	S	[File number] (3 Bytes)	(Check sum)	Delimiter
-----	-----	---	-------------------------	-------------	-----------

As for the response data, either normal reception response data or abnormal reception response data is returned.

Refer to "Response Data" (P.174) for details of both normal reception response data and abnormal reception response data.



When changing the file number through RS-232C, only RS-232C is effective for the following file number switching.

(2) File number readout

This command reads out the file number under editing.

STX	FNO	R	(Check sum)	Delimiter
-----	-----	---	-------------	-----------

As for the response data, either normal reception response data or abnormal reception response data is returned.

Refer to "Response Data" (P.174) for details of the abnormal reception response data.

● Readout response data

STX	FNO	A	[File number] (3 Bytes)	(Check sum)	Delimiter
-----	-----	---	-------------------------	-------------	-----------

● Description of data

Name	Data length	Outline	Content
File number	3	The file number change indicates the file number to be used, and the file number readout indicates the currently using file number.	"001" to "120"



If the specified file does not exist, the abnormal reception response telegram "NAK11" is returned. If perform of marking trigger is sent in this state, the contents of the previous file number are marked.

2. Arbitrary character string (code: STR)

(1) Arbitrary character string setting

This command sets the arbitrary character string of the file selected by file number change (FNO) using ASCII code. The character string set is kept until the next setting is performed or until the file is changed. After changing file and turning OFF the power supply of the laser marker, the character string is cleared.

STX	STR	S	Data (Max. 31 Bytes)	(Check sum)	Delimiter
		Character string No.	Marking character string		

As for the response data, either normal reception response data or abnormal reception response data is returned.

Refer to "Response Data" (P.174) for details of both normal reception response data and abnormal reception response data.

(2) Arbitrary character string readout

This command reads out the specified marking character string.

STX	STR	R	Data (1 Byte)	(Check sum)	Delimiter
		Character string No.			

As for the response data, either normal reception response data or abnormal reception response data is returned.

Refer to "Response Data" (P.174) for details of the abnormal reception response data.

● Readout response data

The marking character string with specified line number is readout in the following format.

STX	STR	A	Data (Max. 31 Bytes)	(Check sum)	Delimiter
		Character string No.	Marking character string		

● Description

Name	Data length	Outline	Content
Character string No.	1	Indicates the character string number to be set in the file.	[Character string No.] ("1" to "4")
Marking character string	Max. 30	Indicates the arbitrary character string to be marked. The character string is set using ASCII code.	Refer to "ASCII Code" (P.198) for details of ASCII code.



REFERENCE

Set the marking character string using the ASCII code (applicable codes: 0x20 to 0x7E except for control codes 0x00 to 0x1F and 0x7F).

E.g.) In case of marking character string "#ABC12345" :

23, 41, 42, 43, 31, 32, 33, 34, 35••• "#ABC12345"

(The values are indicated with hexadecimal numbers.)



CHECK

The arbitrary character string (character string Nos. 1 to 4) is required the preset on the character string setting screen. Refer to "(5) Input optional character string" (P.100) in "3-3-3 Input of Function Character" for details.

3. Counter current value (code: CNT)

(1) Counter current value setting

This command sets the counter current value of the file selected by the file number command (FNO). Note that the counter value set is saved even turning OFF the power supply of the laser marker.

STX	CNT	N	[Counter current value] (8 Bytes)	(Check sum)	Delimiter
-----	-----	---	-----------------------------------	-------------	-----------

As for the response data, either normal reception response data or abnormal reception response data is returned.

Refer to "Response Data" (P.174) for details of both normal reception response data and abnormal reception response data.

(2) Counter current value readout

This command reads out the selected counter current value.

STX	CNT	R	(Check sum)	Delimiter
-----	-----	---	-------------	-----------

As for the response data, either normal reception response data or abnormal reception response data is returned.

Refer to "Response Data" (P.174) for details of the abnormal reception response data.

● Readout response data

STX	CNT	N	[Counter current value] (8 Bytes)	(Check sum)	Delimiter
-----	-----	---	-----------------------------------	-------------	-----------

● Description of data

Name	Data length	Outline	Content
Current value	8	Current value of the counter. No negative value is existed.	"00000000" to "99999999"



- CNT command is available after the file No. changing command (FNO) is set by RS-232C.

4. Counter reset (code: CTR)

(1) Counter reset

This command sets the counter of the file selected by the file number change command (FNO) to the initial value.

STX	CTR	S	(Check sum)	Delimiter
-----	-----	---	-------------	-----------

As for the response data, either normal reception response data or abnormal reception response data is returned.

Refer to "Response Data" (P.174) for details of both normal reception the abnormal reception response data.



- CTR command is available after the file No. changing command (FNO) is set by RS-232C.

5. Status request (code: STS)

(1) Status request

This command reads out the operation status of the laser marker.

STX	STS	R	(Check sum)	Delimiter
-----	-----	---	-------------	-----------

As for the response data, either normal reception response data or abnormal reception response data is returned.

Refer to "Response Data" (P.174) for details of the abnormal reception response data.

● Status request response

STX	STS	A	Data (6 Bytes)	(Check sum)	Delimiter			
			Ready	Shutter	Interlock connector	Laser radiation stop	Counter end	Error occurred status

● Description of data

Name	Data length	Outline	Content
Ready	1	Indicates the marking ready status.	"0"...Marking busy "1"...Marking ready
Shutter	1	Indicates the shutter lever status.	"0"...Shutter closed "1"...Shutter opened
Interlock connector	1	Indicates the interlock connector status.	"0"...Interlock occurred "1"... No interlock occurred
Laser radiation stop	1	Indicates the laser radiation stop input of the I/O connector.	"0"...Laser radiation stop: OFF "1"...Laser radiation stop: ON
Counter end	1	Indicates the counter current value is reached to the counter end value.	"0"...Current value < end value "1"...Current value = end value
Error occurred status	1	Indicates the error is occurred.	"0"...Error occurred "1"...No error occurred

6. Marking trigger (code: MRK)

(1) Marking trigger

This command marks the file under selected by file number change command (FNO) once.

STX	MRK	S	(Check sum)	Delimiter
-----	-----	---	-------------	-----------

As for the response data, either normal reception response data or abnormal reception response data is returned.

Refer to "Response Data" (P.174) for details of both normal reception response data and abnormal reception response data.

7. Marking status transmission permission (code: MST)

(1) Marking status transmission permission setting

This command sets the transmission permission/prohibition of the response indicating the laser marker status at the end of the marking. Note that the transmission permission/prohibition data is initialized into "transmission prohibition" after turning OFF the power supply of the laser marker.

STX	MST	S	[Transmission perm. / proh.] (1 Byte)	(Check sum)	Delimiter
-----	-----	---	---------------------------------------	-------------	-----------

As for the response data, either normal reception response data or abnormal reception response data is returned.

Refer to "Response Data" (P.174) for details of both normal reception response data and abnormal reception response data.

(2) Marking status transmission permission setting readout

This command reads out the response transmission permission/prohibition.

STX	MST	R	(Check sum)	Delimiter
-----	-----	---	-------------	-----------

As for the response data, either normal reception response data or abnormal reception response data is returned.

Refer to "Response Data" (P.174) for details of the abnormal reception response data.

● Readout response data

STX	MST	A	[Transmission perm. / proh.] (1 Byte)	(Check sum)	Delimiter
-----	-----	---	---------------------------------------	-------------	-----------

● Description of data

Name	Data length	Outline	Content
Transmission permission/prohibition	1	Indicates the permission/prohibition of the response transmission.	"0"...Transmission prohibited "1"...Transmission permitted

Data transmission after setting marking status transmission permission

If the marking trigger signal from the external I/O and the marking trigger command through the communication control are accepted after the marking status transmission permission is set, the status is set after the marking operation is finished.

● Readout data

STX	MST	A	[Status] (2 Bytes)	Check sum	Delimiter
-----	-----	---	--------------------	-----------	-----------

● Description of data

Name	Data length	Outline	Content
Status	2	Indicates the status during marking operation.	"00"...Finished marking normally Others...Occurred error code during marking operation

Error code during marking operation

Indication	Status	Description
-	00	Normal marking operation
E04	04	No setting file
E10	10	Under marking Remote interlock connector OPEN
E11	11	Under marking Laser radiation stop input
E12	12	Under marking Shutter operated
E20	20	Cover OPEN
E21 E22	21 22	X/Y galvanometers error
E23	23	Laser error
E25	25	Marking file error
E26	26	Area over

5 Troubleshooting

5-1 Troubleshooting.....	187
5-2 Measures for Indicated Error.....	188

If any operation errors occur, check items below first.

When the problems cannot be resolved by following the below measures, please contact us.

Troubles	Possible Causes	Measures	Ref. Page
Power supply is not turned on.	Power cable is not connected.	Connect the power cable.	40
	Power cable is not plugged in outlet	Insert the plug in the socket.	40
The guide laser does not light.	The shutter lever is not set to the guide laser side.	Set the shutter lever to the guide laser side.	134
Data cannot be marked.	The marking start command is not input.	Input the marking start command.	-
	The distance to the work has not been calibrated.	Calibrate the distance to the work.	54
	Laser power and scan speed are not appropriate to the marking target object.	Raise the laser power or lower the scan speed. Or perform both of them.	126
	The trigger signal is kept ON.	Since the trigger signal sensitive to the edge, input the edge.	164
	The manual shutter is closed (in remote mode).	Open the manual shutter.	43
	The laser radiation stop input of the I/O connector is OFF.	Turn ON the laser radiation stop input from the I/O connector.	13
	The interlock of the power supply BOX is removed.	Attach the optional interlock connector.	12

The following operations occur when any error occurs on the laser marker.

1. "E**" is displayed on the "File No./Error Code" display part in the front panel of the head.
2. The error output of the I/O connector is ON.

This section describes the details and measures of the error code indications in the front panel of the head.

Error Code	Error Indication	Cause	Measure	Ref. Page
E01	Remote interlock connector OPEN	The remote interlock connector for the power supply BOX is opened.	Short-circuit the remote interlock connector for the power supply BOX.	12
E02	Laser radiation stop input OPEN	The laser radiation stop input signal is transmitted from the I/O connector.	Turn ON the laser radiation stop input from the I/O connector.	13
E04	No marking file	No marking file is existed.	Confirm the marking file.	142
			Confirm the file selection input of the I/O connector.	162
E10	Remote interlock connector OPEN during marking	The remote interlock connector of the power supply BOX is opened during marking.	Short-circuit the remote interlock connector of the power supply BOX, and then turn on the key switch again.	12
E11	Laser radiation stop input during marking	The laser radiation stop input signal was transmitted from the I/O connector during marking.	Turn ON the laser radiation stop input from the I/O connector, and then turn on the key switch again.	13
E12	Shutter operation during marking	The shutter operation is occurred during marking.	Turn on the key switch again.	35
E20	Cover OPEN	The cover of the head is opened.	Contact our sales office.	-
E21 E22	X/Y galvanometer error	An error is detected on the galvanometer.	Contact our sales office.	-
		The data is located out of the marking area.	Confirm the position of the setting data, and if required, move the data into the marking area.	132
E23	Laser tube error	An error is detected on the laser mechanism.	Contact our sales office.	-
E25	Marking file error	An error is detected on the marking file.	Contact our sales office.	-
E26	Area over	The data is located out of the marking area.	Confirm the position of the setting data, and if required, move the data into the marking area.	132
E30	System error	Detected a decrease in power supply voltage for the back up battery.	Leave the laser marker with "E30" error status in a few minutes to charge the back up battery. Then, restart the laser marker twice. (Keep 5 seconds or more in the each OFF status.) After the recovery of the error, set the following parameters with PC setting software. 1. Set the date and time of the laser marker on the environment setting screen. 2. Transfer the file data again. * In case using LP-ADP30, set the offset value again.	-
E31 to E39	System error	An error is detected on the laser marker.	Contact our sales office.	-
E90 to E99	Internal communication error	An error is detected in the communication in the product.	Contact our sales office.	-

■ Error Display and I/O Connector Output

When an error is displayed, the ready output and alarm output are as follows.

Error Code	Contents	I/O Connector Output	
		Ready	Alarm
E01	Remote interlock connector "OPEN"	OFF	ON
E02	Laser radiation stop input "OPEN"	OFF	ON
E04	No marking file	ON	OFF
E10	Remote interlock connector "OPEN" during marking	OFF	OFF
E11	Laser radiation stop input during marking	OFF	OFF
E12	Shutter operation during marking	OFF	OFF
E20	Cover OPEN	OFF	OFF
E21	X/Y galvanometer error	OFF	OFF
E22			
E23	Laser tube error	OFF	OFF
E25	Marking file error	OFF	OFF
E26	Area over	OFF	OFF
E30	Backup battery voltage lowered	OFF	OFF
E31 to E39	System error	OFF	OFF
E90 to E99	Internal communication error	-	-

6 Maintenance

6-1 Maintenance.....	191
----------------------	-----

6-1 Maintenance

6-1-1 Contamination of f-theta Lens

In case any contamination or dust adheres to the $f\theta$ lens, the marking performance might be deteriorated or could cause breakage of the $f\theta$ lens. Therefore, be sure to wear the gloves and mask for dealing with the laser marker, and protect the $f\theta$ lens from the attachment of sebum or saliva. When cleaning the $f\theta$ lens, wipe off the lens lightly using the soft cloth or blow off a contamination on the $f\theta$ lens by an air duster for optics.



- Prior to this work, be sure to turn off the system power.
- Do not wipe the $f\theta$ lens strongly or with a sharp-pointed object. Otherwise, it may cause a deterioration in the marking performance.

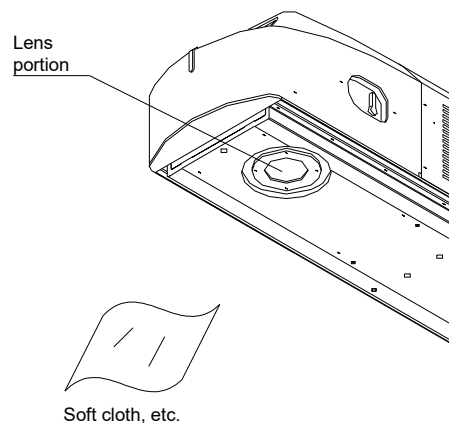

This product contains ZnSe (zinc selenide) in the lens mounted on the laser radiation window. If the lens is damaged, care should be taken of the following.

- In order to prevent from swallowing of flakes or particles, inhaling them, or adhering them to skin, be sure to wear glove, mask and protective goggles.
- When disposing the lens, be sure to obey the disposing method prescribed in the regulations of user's region/country fully. Do not dispose the lens with general industrial waste.
- Do not throw the lens into the fire.
- Do not soak the lens in acid and alkali.

6-1-2 Air Filter

The fan on the side of the head section is activated with the blowing from the external.

In case of using this product in the place where included much dust, take proper measures against dust, such as installing a air filter (optional).

For procurement of the air filter, contact to our sales office.

Parts Names (Model)	Details
Air Filter (LP - AFT30)	Air filter of head section

6-1-3 Replacement of fuse

Replace the fuse of the power supply box when blowing.
The power of the laser marker cannot be turned on if the fuse is blown.

■ Models of replacement parts

Depending on the manufactured period of the laser marker, the available parts model of the fuse is vary. Check the fuse holder type of the power supply box rear side and select the appropriate model form this table. If the user applies any other fuses than the specified one, failure might result.

Laser marker	Fuse holder	Type of the fuse	Model number of the fuse
LP-310 LP-310-A	Circular form	Time lag fuse (Rating 250V, 10A)	0215010.MXP manufactured by Littelfuse, Inc.
	Square form (Lot No. 0FHT or earlier)	Glass fuse (Rating 250V, 10A)	FGBO-A 250V 10A (PbF) manufactured by FUJI TERMINAL INDUSTRIES Co., LTD
LP-310-B LP-310-C	Circular form	Time lag fuse (Rating 250V, 6.3A)	021506.3MXP manufactured by Littelfuse, Inc.

■ Procedures for replacement

1. Remove causes for fuse blowing.
2. Turn OFF the key switch of the power supply box, and disconnect the AC power cable.
3. If the fuse holder on the back of the power supply box is the circular type, turn the fuse holder to remove the fuse.
If the fuse holder on the back of the power supply box is the square type, insert the flathead screwdriver to the hole of the fuse holder to remove the fuse.
4. Replace the fuse with new one.
5. For the circular fuse holder, turn it to fix the fuse.
For the square fuse holder, push it to fix the fuse.

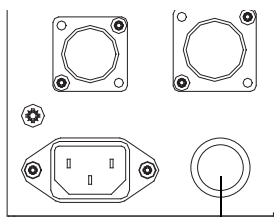

Fuse holder
(Circular type)

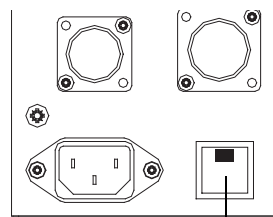

Fuse holder
(Square type)

7 Specification

7-1 Specification	194
7-2 Outer Dimensional Drawing	195

Item		Specification
Model		LP-310 / LP-310-A / LP-310-C / LP-310-B
Scanning method		Galvano-scanning method
Marking laser	Laser type	CO ₂ laser $\lambda=10.6\mu\text{m}$ Class 4 laser product
	Oscillator average output	12W
	Output stability	+/-10% (TYP)*1
Guide laser		Semiconductor laser, $\lambda=655\text{nm}$ Class 2 laser product, Max. output 1mW
Work distance*2		145mm
Marking area		50mmX50mm
Character type	Japanese OS	English capital & small characters • Figures • Hiragana • Katakana • Symbols • Kanji (JIS level-1) • User registered characters (up to 50 types)
	English OS	English capital & small characters • Figures • Symbols • User registered characters (up to 50 types)
Character size (height, width)		0.2mm to 50mm (0.01 mm interval can be set)
Marking interval (interval between characters line pitch)		0mm to 25mm (0.01 mm interval can be set) Fan-like: +/-180° (0.1° interval can be set)
Character array		Straight line • Tilt Angle • Fan-like Form
Scan speed		Max. 2000mm/s
Numbers of Registered Files		Max. 120 files *3
Function		Current date/time marking • Expiry date/time marking • Counter marking Lot marking • RS-232C control Capital • CAD marking • registered character
Input		Trigger, Laser radiation stop, Counter reset, File selection
Output		Power source (+12V), Marking ready, Counter end, Alarm
Cooling method		Forced-air cooling
Power voltage		90V to 132V AC or 180V to 264V AC (including +/-10% voltage fluctuations), 50/60Hz
Power consumption		700VA or less
Environmental temperature		0 °C to 40 °C
Storage temperature		-10 °C to 50 °C (Free from condensatoin and freeze)
Environmental humidity		35 to 85%RH (Free from condensation)
Weight		Head: Approx. 13kg Power supply BOX: Approx. 5kg
Outer dimension	Head	175mmX165mmX710mm
	Power supply box	95mmX210mmX315mm
Battery (Embedded in product)	Type	Vanadium pentoxide lithium rechargeable battery
	Model	VL2330/1VC
	Qty.	1 piece
	Weight	Approx. 4g

*1: Value of output 20% or larger, and at 10min passed after start-up

*2: The work distance has an individual error of +/-2.0mm from product to product.

*3: The number of the registered files differs depending on the file size.

7-2-1 Head

■ LP-310 / LP-310-A / LP-310-C

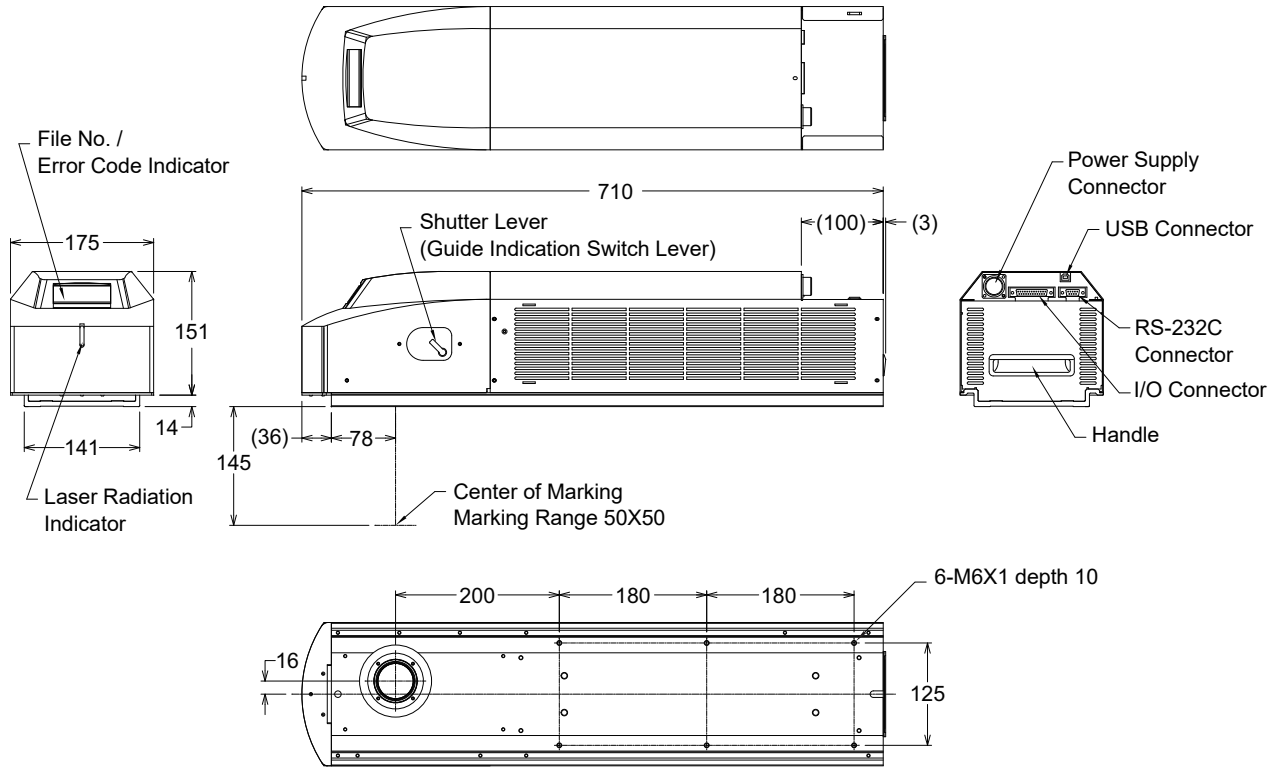

7-2-2 Power Supply BOX

■ LP-310/ LP-310-A

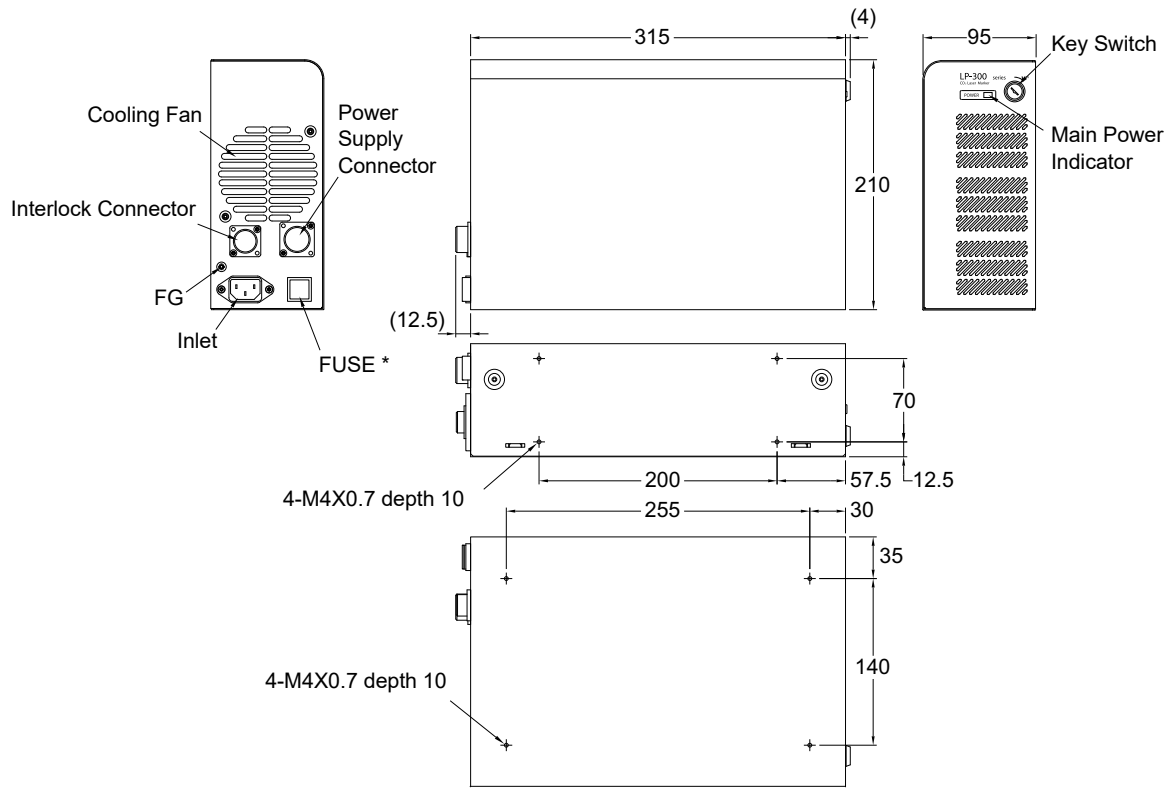

* The type of the fuse holder (square or circular form) varies depending on the manufactured date of the laser marker.

■ LP-310-C

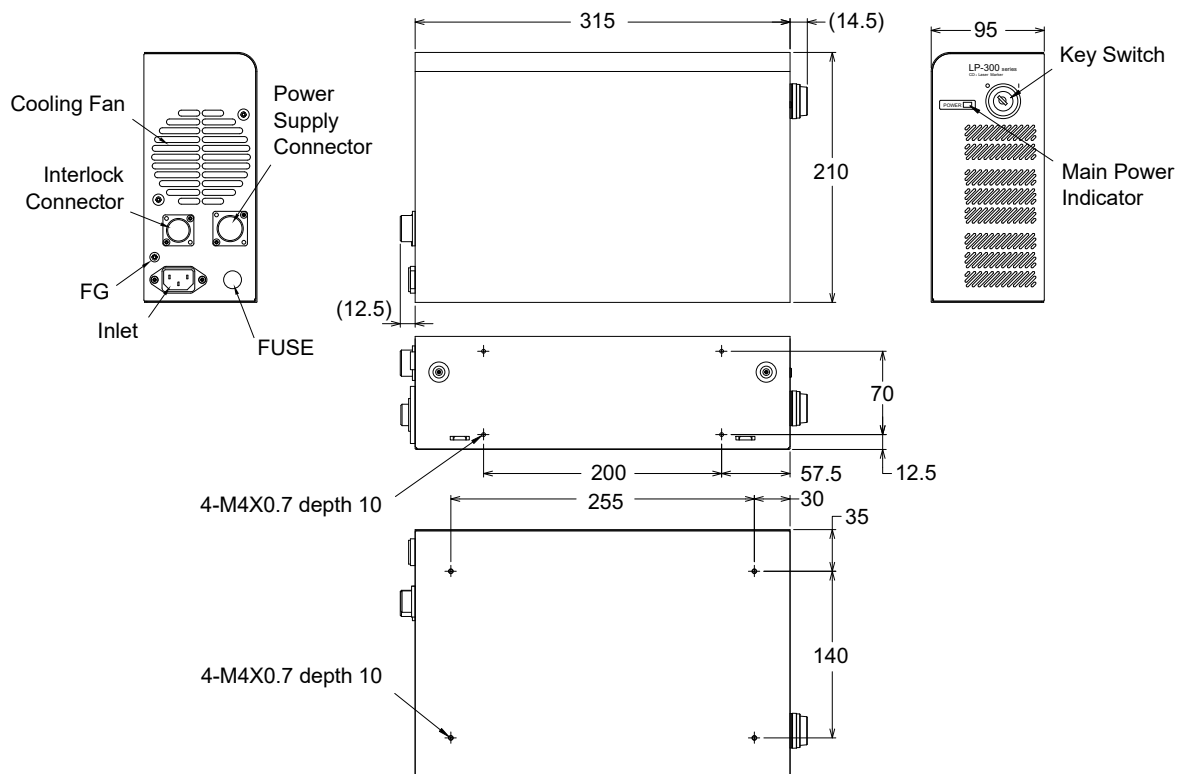

Appendix

Character Code Table	198
Readable DXF File	207
Glossary	209

Character Code Table

■ ASCII Code

Use the ASCII Code shown below for the communication data.
The characters described with [] denote control characters.

Top Bottom	00	10	20	30	40	50	60	70
0	[NUL]		(SP)	0	@	P	'	p
1			!	1	A	Q	a	q
2	[STX]		”	2	B	R	b	r
3			#	3	C	S	c	s
4			\$	4	D	T	d	t
5		[NAK]	%	5	E	U	e	u
6	[ACK]		&	6	F	V	f	v
7			'	7	G	W	g	w
8			(8	H	X	h	x
9)	9	I	Y	i	y
A	[LF]		*	:	J	Z	j	z
B			+	;	K	[k	{
C			,	<	L	¥	l	
D	[CR]		-	=	M]	m	}
E			.	>	N	^	n	~
F			/	?	O	_	o	

- The ASCII code 20 (HEX) represents the space character.
- The control characters supposed to be in the blanks cannot be used with this product.
- When using the external device set by 2byte, NUL00 (HEX) can be used. Please add NUL00 (HEX) before the start code or after delimiter (end code).
- This ASCII Code differs from the ANSI Standard ASCII Code in the symbols denoted by the following codes.
 - 5C (HEX)
 - 60 (HEX)
 - 7E (HEX)

■ Original Font

	Shift JIS	JIS	0	1	2	3	4	5	6	7	8	9	A	B	C	D	E	F		
Symbols	813F	2120			、	。		,	.	・	:	;	?	!	ˆ	°	´	`	¨	
	814F	2130	^	—	—	、	々	々	々	〃	全	々	々	〇	—	—	-	/		
	815F	2140	、	~	//		'	'	“	”	()	[]	[]		
	816F	2150	{	}	<	>	《	》	「	」	『	』	【	】	+	-	±	×		
	8180	2160	÷	=	≠	<	>	≤	≥	∞	∴	♂	♀	°	'	”	°C	¥		
	8190	2170	\$	¢	£	%	#	&	*	@	§	☆	★	○	●	◎	◇			
	819E	2220		◆	□	■	△	▲	▽	▼	※	〒	→	←	↑	↓	=			
	81AE	2230												ε	≡	≡	≡	≡	≡	
	81BE	2240	U	∩										∧	∨	↖	⇒	⇔	∇	
	81CE	2250	∃													∠	⊥	∩	∂	
	81DE	2260	∇	≡	≡	≡	≡	≡	√	∞	∞	∴	∴	∴						
	81EE	2270			Å	%	#	b	♪	†	‡	‡	‡							
Alpha-numeric	824F	2330	0	1	2	3	4	5	6	7	8	9								
	825F	2340		A	B	C	D	E	F	G	H	I	J	K	L	M	N	O		
	826F	2350	P	Q	R	S	T	U	V	W	X	Y	Z							
	8280	2360		a	b	c	d	e	f	g	h	i	j	k	l	m	n	o		
	8290	2370		p	q	r	s	t	u	v	w	x	y	z						

- * According to JIS code “2121”, no character is registered in a blank character (space) or other blank columns.
- * The original fonts 1 to 3 (small size version) is the fonts adjusted the character size of the alphanumeric of the original fonts 1 to 3 to the Kana and Kanji of the JIS level-1 font.
- * The following symbols in the original fonts 1 to 3 and original fonts 1 to 3 (small size version) are represented with the outline characters.

Shift JIS	JIS	Symbols
8179	215A	【
817A	215B	】
819A	217A	★
819C	217C	●
819F	2221	◆
81A1	2223	■
81A3	2225	▲
81A5	2227	▼
81AC	222E	=

■ JIS Level-1 (correspond only to Japanese OS)

JIS X 0208:1997

	Shift JIS	JIS	0	1	2	3	4	5	6	7	8	9	A	B	C	D	E	F
Hiragana	829E	2420		あ	い	う	え	お	か	が	き	ぎ	く					
	82AE	2430	ぐ	け	げ	こ	ご	さ	ざ	し	じ	す	ず	せ	ぜ	そ	ぞ	た
	82BE	2440	だ	ち	ち	っ	つ	づ	て	で	と	ど	な	に	ぬ	ね	の	は
	82CE	2450	ば	ぱ	ひ	び	ぴ	ふ	ぶ	ぷ	へ	べ	ぺ	ほ	ぼ	ぼ	ま	み
	82DE	2460	む	め	も	ゃ	や	ゆ	ゆ	よ	よ	ら	り	る	れ	ろ	わ	わ
	82EE	2470	ゐ	ゑ	を	ん												
Katakana	833F	2520		ァ	ィ	ヱ	ヰ	カ	ガ	キ	グ	ク						
	834F	2530	グ	ケ	ゲ	コ	ゴ	サ	ザ	シ	ジ	ス	ズ	セ	ゼ	ソ	ゾ	タ
	835F	2540	ダ	チ	チ	ッ	ツ	ヅ	テ	デ	ト	ド	ナ	ニ	ヌ	ネ	ノ	ハ
	836F	2550	バ	パ	ヒ	ビ	ピ	フ	ブ	プ	ヘ	ベ	ペ	ホ	ボ	ポ	マ	ミ
	8380	2560	ム	メ	モ	ャ	ヤ	ユ	ヨ	ョ	ラ	リ	ル	レ	ロ	ワ	ワ	
	8390	2570	ヰ	ヱ	ヲ	ン	ヴ	カ	ケ									
Greek character	839E	2620		Α	Β	Γ	Δ	Ε	Ζ	Η	Θ	Ι	Κ	Λ	Μ	Ν	Ξ	Ο
	83AE	2630	Π	Ρ	Σ	Τ	Υ	Φ	Χ	Ψ	Ω							
	83BE	2640		α	β	γ	δ	ε	ζ	η	θ	ι	κ	λ	μ	ν	ξ	ο
	83CE	2650	π	ρ	σ	τ	υ	φ	χ	ψ	ω							
Russian character	843F	2720		А	Б	В	Г	Д	Е	Ё	Ж	З	И	Й	К	Л	М	Н
	844F	2730	О	П	Р	С	Т	У	Ф	Х	Ц	Ч	Ш	Щ	Ъ	Ы	Ь	Э
	845F	2740	Ю	Я														
	846F	2750		а	б	в	г	д	е	ё	ж	з	и	й	к	л	м	н
	8480	2760	о	п	р	с	т	у	ф	х	ц	ч	ш	щ	ъ	ы	ь	э
	8490	2770	ю	я														
あ	889E	3020		亜	唾	娃	阿	哀	愛	挨	始	逢	葵	茜	穉	惡	握	渥
	88AE	3030	旭	葦	芦	鯨	梓	庄	幹	扱	宛	姐	虻	飴	絢	綾	鮎	或
い	88BE	3040	粟	裕	安	庵	按	暗	案	闇	鞍	杏						
	88CE	3050	夷	委	威	尉	惟	意	慰	易	椅	為	畏	異	移	維	緯	胃
	88DE	3060	菱	衣	謂	違	遺	医	井	亥	域	育	郁	磯	一	壺	溢	逸
	88EE	3070	稻	茨	芋	鰯	允	印	咽	員	因	姻	引	飲	淫	胤	蔭	
	893F	3120		院	陰	隱	韻	吋										
	895F	3140	雲															
う	893F	3120						右	宇	烏	羽	迂	雨	卯	鶉	窺	丑	
	894F	3130	碓	臼	渦	嘘	唄	鬱	蔚	鰻	姥	厩	浦	瓜	閨	噂	云	運
	896F	3150	穎	英	衛	詠	銳	液	疫	益	馱	悦	謁	越	閱	榎	厭	円
	8980	3160	園	堰	奄	宴	延	怨	掩	援	沿	演	炎	焰	煙	燕	猿	縁
え	8990	3170	艶	苑	園	遠	鉛	鴛	塩									
	8990	3170								於	汚	甥	凹	央	奧	往	応	
お																		

	Shift JIS	JIS	0	1	2	3	4	5	6	7	8	9	A	B	C	D	E	F	
お	899E	3220		押	旺	横	欧	殴	王	翁	襖	鶯	鷗	黄	岡	冲	荻	億	
	89AE	3230	屋	憶	臆	桶	牡	乙	俺	卸	恩	温	穩	音					
か	89BE	3240	伽	伽	佳	加	可	嘉	夏	嫁	家	寡	科	暇	果	架	歌	河	
	89CE	3250	火	珂	禍	禾	稼	箇	花	苛	茄	荷	華	菓	蝦	課	嘩	貨	
	89DE	3260	迦	過	霞	蚊	俄	峨	我	牙	画	臥	芽	蛾	賀	雅	餓	駕	
	89EE	3270	介	会	解	回	塊	壞	迴	快	怪	悔	恢	懷	戒	拐	改		
	8A3F	3320		魁	晦	械	海	灰	界	皆	繪	芥	蟹	開	階	貝	凱	効	
	8A4F	3330	外	咳	害	崖	慨	概	涯	碍	蓋	街	該	鎧	骸	湮	馨	蛙	
	8A5F	3340	垣	柿	蛎	鈎	劃	嚇	各	廓	扞	攪	格	核	殼	獲	確	穫	
	8A6F	3350	覚	角	赫	較	郭	閣	隔	革	学	岳	樂	額	顎	掛	笠	檉	
	8A80	3360	櫃	梶	鯽	渦	割	喝	恰	括	活	渴	滑	葛	褐	轄	且	鯉	
	8A90	3370	叶	柁	樺	鞆	株	兜	竈	蒲	釜	鎌	嚙	鴨	栢	茅	萱		
	8A9E	3420		粥	刈	苜	瓦	乾	侃	冠	寒	刊	勘	勸	卷	喚	堪	姦	
	8AAE	3430	完	官	寬	干	幹	患	感	慣	憾	換	敢	柑	桓	棺	款	飲	
	8ABE	3440	汗	漢	澗	漣	環	甘	監	看	竿	管	簡	緩	缶	翰	肝	艦	
	8ACE	3450	莞	覲	諫	貫	還	鑑	間	閑	閑	陷	韓	館	館	丸	含	岸	
	8ADE	3460	巖	玩	癌	眼	岩	翫	贗	雁	頑	顏	願						
	き	8AEE	3470	基	奇	嬉	寄	岐	希	幾	忌	揮	机	旗	既	期	棋	棄	
8B3F		3520		機	帰	毅	氣	汽	畿	祈	季	稀	紀	徽	規	記	貴	起	
8B4F		3530	軌	輝	飢	騎	鬼	龜	偽	儀	妓	宜	戲	技	擬	欺	犧	疑	
8B5F		3540	祇	義	蟻	誼	議	掬	菊	鞠	吉	吃	喫	桔	橘	詰	砧	杵	
8B6F		3550	黍	却	客	脚	虐	逆	丘	久	仇	休	及	吸	宮	弓	急	救	
8B80		3560	朽	求	汲	泣	灸	球	究	窮	笈	級	糾	給	旧	牛	去	居	
8B90		3570	巨	拒	扠	拳	渠	虚	許	距	鋸	漁	禦	魚	亨	享	京		
8B9E		3620		供	俠	僑	兇	競	共	凶	協	匡	卿	叫	喬	境	峽	強	
8BAE		3630	彊	怯	恐	恭	挾	教	橋	況	狂	狹	矯	胸	脅	興	蕎	郷	
8BBE		3640	鏡	響	饗	驚	仰	凝	堯	曉	業	局	曲	極	玉	桐	籽	僅	
8BCE		3650	勤	均	巾	錦	斤	欣	欽	琴	禁	禽	筋	緊	芹	菌	衿	襟	
8BDE		3660	謹	近	金	吟	銀												
<		8BEE	3670	駒	具	愚	虞	喰	空	偶	寓	遇	隅	串	櫛	釧	屑	屈	
		8C3F	3720		掘	窟	沓	靴	轡	窪	熊	隈	糸	栗	繰	桑	鋤	勲	君
		8C4F	3730	薰	訓	群	軍	郡											
け		8C5F	3740	契	形	徑	恵	慶	慧	憩	掲	携	敬	景	桂	溪	畦	稽	系
	8C6F	3750	経	繼	繫	罨	莖	荊	蚩	計	詣	警	輕	頸	鷄	芸	迎	鯨	
	8C80	3760	劇	戟	擊	激	隙	析	傑	欠	決	潔	穴	結	血	訣	月	件	

	Shift JIS	JIS	0	1	2	3	4	5	6	7	8	9	A	B	C	D	E	F
け	8C90	3770	儉	倦	健	兼	券	劍	喧	圈	堅	嫌	建	憲	懸	拳	捲	
	8C9E	3820		檢	権	牽	犬	献	研	硯	絹	梟	肩	見	謙	賢	軒	遣
	8CAE	3830	鍵	陰	頭	験	鯨	元	原	巖	幻	弦	減	源	玄	現	絃	舷
こ	8CBE	3840	言	諺	限		個	古	呼	固	姑	孤	己	庫	弧	戸	故	枯
	8CCE	3850	湖	狐	糊	袴	股	胡	菰	虎	誇	跨	鈷	雇	顧	鼓	五	互
	8CDE	3860	伍	午	呉	吾	娛	後	御	悟	梧	檣	瑚	碁	語	誤	護	醐
	8CEE	3870	乞	鯉	交	佼	侯	候	倖	光	公	功	効	勾	厚	口	向	
	8D3F	3920		后	喉	坑	垢	好	孔	孝	宏	工	巧	巷	幸	広	庚	康
	8D4F	3930	弘	恒	慌	抗	拘	控	攻	昂	晃	更	杭	校	梗	構	江	洪
	8D5E	3940	浩	港	溝	甲	皇	硬	稿	糠	紅	紘	絞	綱	耕	考	肯	肱
	8D6F	3950	腔	膏	航	荒	行	衡	講	貢	購	郊	醉	鉞	砧	鋼	閤	降
	8D80	3960	項	香	高	鴻	剛	劫	号	合	壕	拷	濠	豪	轟	趨	克	刻
	8D90	3970	告	国	穀	酷	鵠	黒	獄	漉	腰	甌	忽	惚	骨	狛	込	
	8D9E	3A20		此	頃	今	困	坤	墾	婚	恨	懇	昏	昆	根	梱	混	痕
	8DAE	3A30	紺	良	魂													
さ					些		佐	又	峻	嵯	左	差	查	沙	磋	砂	詐	鎖
	8DBE	3A40	娑	坐	座	挫	債	催	再	最	哉	塞	妻	宰	彩	才	採	栽
	8DCE	3A50	歳	濟	災	采	犀	碎	砦	祭	斎	細	菜	裁	載	際	劑	在
	8DDE	3A60	材	罪	財	冴	坂	阪	堺	榊	肴	咲	崎	埼	碕	鷺	作	削
	8DEE	3A70	咋	搾	昨	朔	柵	窄	策	索	錯	桜	鮭	笹	匙	冊	刷	
	8E3F	3B20		察	拶	撮	擦	札	殺	薩	雜	阜	鯖	捌	鑄	絞	皿	晒
	8E4F	3B30	三	傘	参	山	慘	撒	散	棧	燦	珊	産	算	纂	蚕	讚	賛
し	8E5F	3B40	酸	餐	斬	暫	残											
							仕	仔	伺		使	刺	司	史	嗣	四	士	始
	8E6F	3B50	姉	姿	子	屍	市	師	志	思	指	支	孜	斯	施	旨	枝	止
	8E80	3B60	死	氏	獅	祉	私	糸	紙	紫	肢	脂	至	視	詞	詩	試	誌
	8E90	3B70	諮	資	賜	雌	飼	齒	事	似	侍	児	字	寺	慈	持	時	
	8E9E	3C20		次	滋	治	爾	璽	痔	磁	示	而	耳	自	蒔	辞	汐	鹿
	8EAE	3C30	式	識	鳴	竺	軸	穴	雫	七	叱	執	失	嫉	室	悉	湿	漆
	8EBE	3C40	疾	質	実	蔀	篠	悞	柴	芝	屢	蕊	縞	舎	写	射	捨	赦
	8ECE	3C50	斜	煮	社	紗	者	謝	車	遮	蛇	邪	借	勺	尺	杓	灼	爵
	8EDE	3C60	酌	积	錫	若	寂	弱	惹	主	取	守	手	朱	殊	狩	珠	種
	8EEE	3C70	腫	趣	酒	首	儒	受	呪	寿	授	樹	綬	需	囚	収	周	
	8F3F	3D20		宗	就	州	修	愁	拾	洲	秀	秋	終	繡	習	臭	舟	蒐
	8F4F	3D30	衆	襲	讐	蹴	輯	週	曾	酬	集	醜	什	住	充	十	従	戎
	8F5F	3D40	柔	汁	洪	獸	縦	重	銃	叔	夙	宿	淑	祝	縮	肅	塾	熟
8F6F	3D50	出	術	述	俊	峻	春	瞬	竣	舜	駿	准	循	旬	楯	殉	淳	
8F80	3D60	準	潤	盾	純	巡	遵	醇	順	処	初	所	暑	曙	渚	庶	緒	

	Shift JIS	JIS	0	1	2	3	4	5	6	7	8	9	A	B	C	D	E	F		
し	8F90	3D70	署	書	薯	諸	諸	助	叙	女	序	徐	恕	鋤	除	傷	償			
	8F9E	3E20		勝	匠	升	召	哨	商	唱	嘗	獎	妾	娼	宵	將	小	少		
	8FAE	3E30	尚	庄	床	廠	彰	承	抄	招	掌	捷	昇	昌	昭	晶	松	梢		
	8FBE	3E40	樟	樵	沼	消	涉	湘	燒	焦	照	症	省	硝	礁	祥	称	章		
	8FCE	3E50	笑	粧	紹	肖	菖	蔣	蕉	衝	裳	訟	証	詔	詳	象	賞	醬		
	8FDE	3E60	鉦	鍾	鐘	障	鞞	上	丈	丞	乘	冗	剩	城	場	壤	嬢	常		
	8FEE	3E70	情	擾	条	杖	淨	状	畳	穰	蒸	讓	釀	錠	囑	埴	飾			
	903F	3F20		拭	植	殖	燭	織	職	色	触	食	蝕	辱	尻	伸	信	侵		
	904F	3F30	唇	娠	寢	審	心	慎	振	新	晋	森	榛	浸	深	申	疹	真		
	905F	3F40	神	秦	紳	臣	芯	薪	親	診	身	辛	進	針	震	人	仁	刃		
	906F	3F50	塵	壬	尋	甚	尽	腎	訊	迅	陣	韌								
す													筭	誨	須	酢	囟	厨		
	9080	3F60	逗	吹	垂	帥	推	水	炊	睡	粹	翠	衰	遂	醉	錐	錘	随		
	9090	3F70	瑞	髓	崇	嵩	数	枢	趨	雛	据	杉	相	菅	頗	雀	裾			
	909E	4020		澄	摺	寸														
せ	909E	4020					世	瀬	畝	是	凄	制	勢	姓	征	性	成	政		
	90AE	4030	整	星	晴	棲	栖	正	清	牲	生	盛	精	聖	声	製	西	誠		
	90BE	4040	誓	請	逝	醒	青	静	齐	税	脆	隻	席	惜	戚	斥	昔	析		
	90CE	4050	石	積	籍	績	脊	責	赤	跡	蹟	碩	切	拙	接	撰	折	設		
	90DE	4060	窃	節	説	雪	絶	舌	蟬	仙	先	千	占	宣	専	尖	川	戰		
	90EE	4070	扇	撰	栓	柅	泉	浅	洗	染	潜	煎	煽	旋	穿	箭	線			
	913F	4120		織	羨	腺	舛	船	薦	詮	賤	踐	選	遷	錢	銑	閃	鮮		
	914F	4130	前	善	漸	然	全	禪	繕	膳	糲									
そ													噌	塑	岨	措	曾	曾	楚	
	915F	4140	狙	疏	疎	礎	祖	租	粗	素	組	蘇	訴	阻	邈	鼠	僧	創		
	916F	4150	双	叢	倉	喪	壯	奏	爽	宋	層	匝	惣	想	搜	掃	挿	搔		
	9180	4160	操	早	曹	巢	槍	槽	漕	燥	争	瘦	相	窓	糟	総	綜	聡		
	9190	4170	草	莊	葬	蒼	藻	装	走	送	遭	鎗	霜	騷	像	増	憎			
	919E	4220		臟	蔵	贈	造	促	側	則	即	息	捉	束	測	足	速	俗		
	91AE	4230	属	賊	族	続	卒	袖	其	揃	存	孫	尊	損	村	遜				
																			他	多
た	91BE	4240	太	汰	訖	唾	墮	妥	惰	打	柁	舵	檣	陀	馱	驛	体	堆		
	91CE	4250	対	耐	岱	帯	待	怠	態	戴	替	泰	滞	胎	腿	苔	袋	貸		
	91DE	4260	退	逮	隊	黛	鯛	代	台	大	第	醜	題	鷹	滝	瀧	卓	啄		
	91EE	4270	宅	托	挾	拓	沢	濯	琢	託	鐸	濁	諾	茸	凧	蛸	只			
	923F	4320		叩	但	達	辰	奪	脱	翼	豎	辿	棚	谷	狸	鱈	樽	誰		
	924F	4330	丹	単	嘆	坦	担	探	旦	歎	淡	湛	炭	短	端	筆	綻	耽		
	925F	4340	胆	蛋	誕	鍛	団	壇	彈	断	暖	檀	段	男	談					
ち																		値	知	地

	Shift JIS	JIS	0	1	2	3	4	5	6	7	8	9	A	B	C	D	E	F	
ち	926F	4350	弛	恥	智	池	痴	稚	置	致	蚰	遲	馳	築	畜	竹	筑	蓄	
	9280	4360	逐	秩	窒	茶	嫡	着	中	仲	宙	忠	抽	昼	柱	注	虫	衷	
	9290	4370	註	耐	鑄	駐	檣	瀟	猪	苧	著	貯	丁	兆	凋	喋	寵		
	929E	4420		帖	帳	庁	弔	張	彫	徵	懲	挑	暢	朝	潮	牒	町	眺	
	92AE	4430	聽	脹	腸	蝶	調	諜	超	跳	鈹	長	頂	鳥	勅	抄	直	朕	
	92BE	4440	沈	珍	賃	鎮	陳												
つ	92CE	4450	槻	佃	漬	柘	辻	蔦	綴	鏑	椿	潰	坪	壺	孀	紬	爪	吊	
	92DE	4460	釣	鶴															
	92EE	4470	悌	抵	挺	提	梯	汀	碇	禎	程	締	艇	訂	諦	蹄	逋		
て	933F	4520		邸	鄭	釘	鼎	泥	摘	擢	敵	滴	的	笛	適	鎬	溺	哲	
	934F	4530	徹	撤	轍	迭	鉄	典	填	天	展	店	添	纏	甜	貼	転	顛	
	935F	4540	点	伝	殿	澱	田	電											
	936F	4550	登	菟	賭	途	都	鍍	砥	砺	努	度	土	奴	怒	倒	党	冬	
	9380	4560	凍	刀	唐	塔	塘	套	宕	島	嶋	悼	投	搭	東	桃	禱	棟	
	9390	4570	盜	淘	湯	涛	灯	燈	当	痘	禱	等	答	筒	糖	統	到		
と	939E	4620		董	蕩	藤	討	騰	豆	踏	逃	透	鐙	陶	頭	騰	鬪	働	
	93AE	4630	動	同	堂	導	懂	撞	洞	瞳	童	胴	苟	道	銅	峠	鴉	匿	
	93BE	4640	得	徳	流	特	督	禿	篤	毒	独	読	析	椽	凸	突	椽	届	
	93CE	4650	鳶	苦	寅	酉	瀨	噸	屯	惇	敦	沌	豚	遁	頓	吞	曇	鈍	
	93DE	4660	奈	那	内	乍	凧	薙	謎	灘	捺	鍋	檜	馴	縄	啜	南	楠	
	93EE	4670	軟	難	汝														
						二	尼	忒	迓	句		賑	肉	虹	廿	日	乳	入	
				如	尿	菲	任	妊	忍	認									
ぬ	943F	4720									濡								
ね												禰	祢	寧	葱	猫	熱	年	
	944F	4730	念	捻	撚	燃	粘												
の								乃	迺	之	埜	囊	惱	濃	納	能	腦	膿	
	945F	4740	農	覗	蚤														
は						巴	把	播	霸	杷	波	派	琶	破	婆	罵	芭	馬	
	946F	4750	俳	廢	拝	排	敗	杯	盃	牌	背	肺	輩	配	倍	培	媒	梅	
	9480	4760	煤	煤	狙	買	売	賠	陪	這	蠅	秤	矧	菽	伯	剥	博	拍	
	9490	4770	柏	泊	白	箔	粕	舶	薄	迫	曝	漠	爆	縛	莫	駁	麥		
	949E	4820		函	箱	碓	箸	肇	筈	櫨	幡	肌	畑	畠	八	鉢	澆	発	
	94AE	4830	醜	髮	伐	罰	拔	筏	闕	鳩	嘶	塙	蛤	隼	伴	判	半	反	
	94BE	4840	叛	帆	搬	斑	板	汜	汎	版	犯	班	畔	繁	般	藩	販	範	

	Shift JIS	JIS	0	1	2	3	4	5	6	7	8	9	A	B	C	D	E	F		
は	94CE	4850	采	煩	頒	飯	挽	晚	番	盤	磬	蕃	蚤							
ひ			匪	卑	否	妃	庇													
			94DE	4860	彼	悲	扉	批	披	斐	比	泌	疲	皮	碑	秘	緋	罷	肥	被
			94EE	4870	誹	費	避	非	飛	樋	簸	備	尾	微	枇	毘	琵琶	眉	美	
			953F	4920		鼻	柎	稗	匹	疋	髭	彦	膝	菱	肘	弼	必	畢	筆	逼
			954F	4930	桧	姫	媛	紐	百	謬	俵	彪	標	氷	漂	瓢	票	表	評	豹
			955F	4940	廟	描	病	秒	苗	錨	鋌	蒜	蛭	鱮	品	彬	斌	浜	瀕	貧
956F	4950	賓	頻	敏	瓶															
ふ							不	付	埠	夫	婦	富	富	布	府	怖	扶	敷		
	9580	4960	斧	普	浮	父	符	腐	膚	芙	譜	負	賦	赴	阜	附	侮	撫		
	9590	4970	武	舞	葡	蕪	部	封	楓	風	葺	蒨	伏	副	復	幅	服			
	959E	4A20		福	腹	複	覆	淵	弗	弘	沸	仏	物	鮒	分	吻	噴	墳		
	95AE	4A30	憤	扮	焚	奮	粉	糞	紛	雰	文	聞								
へ														丙	併	兵	塀	幣	平	
	95BE	4A40	弊	柄	並	蔽	閉	陛	米	頁	僻	壁	癖	碧	別	警	蔑	篋		
	95CE	4A50	偏	變	片	篇	編	辺	返	遍	便	勉	婉	弁	鞭					
ほ																保	舗	舗		
	95DE	4A60	圃	捕	步	甫	補	輔	穗	募	墓	慕	戊	暮	母	簿	菩	倣		
	95EE	4A70	俸	包	呆	報	奉	宝	峰	峯	崩	庖	抱	捧	放	方	朋			
	963F	4B20		法	泡	烹	砲	縫	胞	芳	萌	蓬	蜂	褒	訪	豊	邦	鋒		
	964F	4B30	飽	鳳	鵬	乏	亡	傍	剖	坊	妨	帽	忘	忙	房	暴	望	某		
	965F	4B40	棒	冒	紡	肪	膨	謀	貌	貿	鉾	防	吠	頰	北	僕	卜	墨		
	966F	4B50	撲	朴	牧	睦	穆	卸	勃	沒	殆	堀	幌	奔	本	翻	凡	盆		
ま	9680	4B60	摩	磨	魔	麻	埋	妹	昧	枚	每	哩	禎	幕	膜	枕	鮪	枉		
	9690	4B70	鱒	榭	亦	俣	又	抹	末	沫	迄	俛	繭	磨	万	慢	滿			
み	969E	4C20		漫	蔓															
						味	未	魅	巳	箕	岬	密	蜜	湊	蓑	稔	脈	妙		
	96AE	4C30	耗	民	眠															
む	96AE	4C30				務	夢	無	牟	矛	霧	鷓	棕	婿	娘					
め	96AE	4C30														冥	名	命		
	96BE	4C40	明	盟	迷	銘	鳴	姪	牝	滅	免	棉	綿	緬	面	麵				
も	96BE	4C40															摸	模		
	96CE	4C50	茂	妄	孟	毛	猛	盲	網	耗	蒙	儲	木	默	目	柰	勿	餅		
	96DE	4C60	尤	戾	勑	貰	問	悶	紋	門	匆									
や												也	冶	夜	爺	耶	野	弥		
ゆ	96EE	4C70	矢	厄	役	約	薬	訳	躍	靖	柳	藪	鍵							
														愉	愈	油	癒			
	973F	4D20		諭	輸	唯	佑	優	勇	友	宥	幽	悠	憂	揖	有	柚	湧		

	Shift JIS	JIS	0	1	2	3	4	5	6	7	8	9	A	B	C	D	E	F
ゆ よ	974F	4D30	涌	猶	猷	由	祐	裕	誘	遊	邑	郵	雄	融	夕			
															予	余	与	
	975F	4D40	誉	輿	預	傭	幼	妖	容	庸	揚	搖	擁	曜	楊	樣	洋	溶
ら	976F	4D50	熔	用	窯	羊	耀	葉	蓉	要	謠	踊	遙	陽	養	慾	抑	欲
			9780	4D60	沃	浴	翌	翼	淀									
	9790	4D70	乱	卵	嵐	欄	濫	藍	蘭	覽								
り	979E	4E20	痢	裏	裡		里	離	陸	律	率	立	莅	掠	略	劉	流	溜
			97AE	4E30	琉	留	硫	粒	隆	竜	龍	侶	慮	旅	虜	了	亮	僚
	97BE	4E40	寮	料	梁	涼	獵	療	瞭	稜	糧	良	諒	遼	量	陵	領	力
る	97CE	4E50	緑	倫	厘	林	淋	熒	琳	臨	輪	隣	鱗	麟				
			97DE	4E60	類												瑠	墨
	97EE	4E70	齡	曆	歷	列	劣	烈	裂	廉	恋	憐	漣	煉	簾	練	聯	
ろ	983F	4F20	蓮	連	鍊		呂	魯	櫓	炉	賂	路	露	勞	婁	廊	弄	朗
			984F	4F30	樓	榔	浪	漏	牢	狼	籠	老	龔	蠟	郎	六	麓	祿
	985F	4F40	論															
わ	986F	4F50	倭	和	話		歪	賄	脇	惑	梓	鷲	互	亘	鰐	詫	藁	蕨
			椀	湾	碗	腕												
User registered character	F13F	8120																

*The registrable characters are up to 50 types designated in JIS codes 8121 to 8152.



- To create the new font as a “user registered character”, contact our sales office.
- In the initial status, the registration character is not involved in the font file “JIS level-1”.



- In case of using the English OS, the JIS CODE is registered into the user font. This JIS code is used for marking the registration character.

Readable DXF File

LP-310 setting software is laser marker can read the DXF format file described below.

- DXF-R12, R13, R14 format
The data created either by AutoCAD (“AutoCAD” is produced by Autodesk, Inc.) is recommended to apply as the DXF format file data to be read. Followings are how to create DXF format file using AutoCAD.
- DXF-R12, R13, R14 format file
The DXF-R12, R13, R14 format file to be created by Autocad can be prepared using the “Writing” function in “File” menu.
At this time, select “AutoCAD LT R2/R12/R13/R14 DXF” from “File Format” in “Data Writing” dialog, and then click [Save] button.
Refer to “Operation Method” that is appeared on the screen by searching the reference pages on the online help of AutoCAD using the keyword such as “Writing”.

■ Graphic Applied on AutoCAD and Corresponding Table for Marking Object using Laser Marker

Both correspondable graphic function on AutoCAD for LP-310 setting software and corresponding marking object using laser marker are listed in the following table.

For reading DXF file with LP-310 setting software using the CAD software, review the graphic type, function referring to the following table.

DXF Version	DXF Element		Correspondable	Remarks	
	Entity Name	Graphic Name			
R12J R13J R14	3DFACE	3D face	N		
	3DLINE	3D line	N		
	ARC	Arc	Y		
	ATTDEF	Attribute definition	N		
	ATTRIB	Attribute	N		
	CIRCLE	Circle	Y		
	DIMENSION	Dimension	N		
	INSERT	Insert graphic	Y		
	LINE	Segment	Y		
	POINT	Point	N		
	POLYLINE	2D Polyline		Y	Bold line is not supported.
		3D Polyline		N	
	SEQEND	Sequence end	Y	SEQEND in combination with POLYLINE is available.	
	SHAPE	Shape	N		
	SOLID	2D paint	Y	The SOLID element is converted into outline and filling lines. The filling lines are arranged either horizontally or vertically.	
	TEXT	Character	Y	The font of the TEXT element is replaced with the laser marker font. In the marking data, the TEXT element is disassembled and converted into lines. You cannot treat it as a character.	
TRACE	Bold line	N			
VERTEX	Vertex	Y	VERTEX in combination with POLYLINE is available.		
VIEWPORT	View port	N			

DXF Version	DXF Element		Correspondable	Remarks
	Entity Name	Graphic Name		
R13J R14	3DSOLID	3D paint	N	
	ACAD_PROXY_ENTITY	Proxy graphic	N	
	BODY	Body	N	
	ELLIPSE	Ellipse	Y	
	IMAGE	Image	N	
	LEADER	Lead line	N	
	LWPOLYLINE	Light weight polyline	Y	Bold line is not supported.
	MLINE	Multi-line	N	
	MTEXT	Multi-text	Y	The font of the MTEXT element is replaced with the laser marker font. In the marking data, the MTEXT element is disassembled and converted into lines. You cannot treat it as a character.
	OLEFRAME	OLE frame	N	
	OLE2FRAME	OLE2 frame	N	
	RAY	Radiation (half line)	Y	
	REGION	Region	N	
	SPLINE	Free curve	Y	
	TOLERANCE	Geometric tolerance	N	
XLINE	Line (straight line)	Y		
R14	HATCH	Hatching	Y	Graphics which contain POLYLINE or SPLINE are not supported. The HATCH element is converted into outline and filling lines. The filling lines are arranged either horizontally or vertically.
	ARCALIGNEDTEXT	Character string on arc	N	
	RTEXT	Reference character string	N	
	WIPEOUT	Masking graphic	N	

Y: Markable
N: Non-markable



The DXF file including entity not applicable to the laser marker cannot read.



- In the case of setting CAD marking magnification for laser marker to “under 1X”, the graphic including curve is not marked as just the preset marking image.

Glossary

Some terms of the laser marker are specific to the laser marker and are difficult to understand. There is a summary of the outlines of such terms and the pages in which the terms are mentioned in this operation manual.

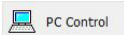
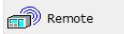
	Term	Outline	
Outline	LP-310 Setting Software	This is the software needed for setting the characters and conditions to be marked by the laser marker LP-310.	
	Radiation safety standard for laser products Performance standards for light emitting products	These are the standards established for using the laser safely. Products are classified in accordance with the degree of danger, and LP-310 is classified into Class 4, the highest class.	
Initial setting	Language Type	The language displayed by the setting software can be switched between Japanese and English. Caution: Though the language is switchable between Japanese and English on Japanese Windows, this language switching function is not compatible with English Windows, that is, only English is available for displaying.	
	Environment Setting	The operational environment of the laser marker is set. Laser marker : The internal clock, system offset, RS-232C conditions of the laser marker can be set. PC : The size of the screen for displaying the setting software and the font of the character to be marked can be set.	
Operation button	File Selection	The marking file to be edited/set is selected.	
	Character Setting	The character string and function character to be marked are set.	
	Function Setting	The condition for function set at the character setting is set.	
	Marking Condition	The condition for character string or CAD files to be marked in relation to the size and position are set.	
	Laser Setting	The output and speed of the laser for marking are set.	
	Image Display	The character string and size and position of the CAD file can be confirmed before marking.	
	Guide Indication	The actual character string and condition are traced by the guide laser before marking. This function is available for rough alignment, etc. (Guide indication is available only when the shutter lever is closed or set to the guide laser side.)	
	Test Marking	The test marking is performed with the characters and condition the user set. This function is useful for fine-adjusting the marking data on the actual marked work.	
	Send/Read	File Transfer	The data created by the setting software is transferred to the laser marker. This operation enables to mark in remote mode.
		File List	The files already transferred to the laser marker can be confirmed, and displayed in the form of the list.
		Backup	The backup file of the marking data transferred to the laser marker can be created, and saved into the personal computer. The backup file is saved with the extension ".LLB".
		Restore	The backup file can be written back to the laser marker.
	PC Control/Remote	The button to be displayed on the screen is differed depending on the status of the laser marker. When the laser marker is in remote mode :  When the laser marker is in PC control mode:  PC Control : Indicates that the laser marker is in the controlled status from the personal computer. The test marking, transfer•read of the guide display data are performed in this PC control mode. Remote : Indicates that the laser marker is in the automatic control mode for marking start with the input signal sending from the external device.	

		Term	Outline
Setting	Registration File		This is the file to be saved in the PC. Max. 120 marking files (sub files) that have been set are included in the file.
	Marking File		This is a set of max. 120 files (sub files) in which the conditions for marking data by the laser marker are set. This set becomes the registration file (parent file).
	Arbitrary String		This is the string set through the communications from external device indicating with ASCII code.
	Bold Character Line Width		The thickness of the character stroke is almost determined according to the laser power, scan speed, spot diameter, and material of the object to be marked. If the user needs to perform marking with a line width larger than the determined width, input the desired line width of the character with this function. In case of marking large character, it is better for the visibility to set the thicker line width.
	Laser Power Revise		The laser power set in the laser setting screen can be corrected. Since correction can be applied for each condition number, for example, if large characters and small characters are mixed in the data, data may be marked finely on the whole by adjusting laser power to larger characters and reducing the laser power to smaller characters by correction.
	Scan Speed Revise		The scan speed set in the laser setting screen can be corrected. By using this scan speed revise with the scan speed revise together, the data may be marked finely on the whole.
	Mirror Inversion		The set data is automatically converted into a position symmetrical with respect to the X- or Y-axis. There are two types for the mirror inversion, vertical mirror inversion and horizontal mirror inversion.
	Offset	Offset	The whole setting screen of each file can be shifted in the X, Y, and θ directions. When the marking condition of one file is used in wide-range, this function is available for shifting the marking position in accordance with each condition.
		System Offset	Data of all the files transferred to the laser marker can be shifted in the X and Y directions. In case of operating several laser marker with one setting file, this function is available for correcting the errors specific to the laser marker and errors related to the installation.
	Laser Power		The average power of the marking laser beam is indicated as a rank ranging from 0.5 to 100. For the CO ₂ laser, the laser power varies the pulse duty cycle. If the scan speed is set with constant speed, the marked character gets lighter as the laser power is lowered, and it gets darker as the laser power is raised.
Scan Speed		This indicates the max. scan speed of the marking laser beam. This is equivalent to the maximum transfer speed of a spot on the work for marking. If the laser power is set with constant power, the marked character gets lighter as the scan speed is raised, and it gets darker as the scan speed is lowered.	

	Term	Outline
Setting	Line Width	This is the setting value for creating clearance at the intersection of the character strokes. This is the function for controlling deep engraving due to the overlap at the intersection of the character strokes. Since the line width varies depending on the object to be marked and laser conditions, it is desirable to confirm the line width by actual marking data.
	Laser Start Wait	This is the function for adjusting the waiting time of turning ON the laser at the start point of the marked line segment. The marked character gets darker as this value decreases.
	Laser End Wait	This is the function for adjusting the waiting time of turning OFF the laser at the end point of the marked line segment. The marked character gets darker as this value increases.
	Marking Pitch	The bold character marking function draws bold strokes using several line segments. This is the setting of the pitch of the several line segments. This setting differs depending on the material of the object to be marked, however, if the pitch is too small, the character may be engraved deeply.
	Marking Quality	For LP-310, the curves are displayed by dividing them into straight lines. This function is used for setting the extent to which they will be divided into straight lines.
	Laser Check	For the laser check, laser beam is continuously emitted to a desired spot in the marking area.
Specification	Work Distance	This is the reference distance from the bottom reference plane of the laser marker to the minimum spot of the marking laser. This distance depends on individual product, and there is a variation of around +/-2.0mm.
	Marking Range	This is the max. range the laser marker can perform the marking.
	Minimum Spot Diameter (theoretical value)	The spot diameter of 1/e2 to the peak at the minimum spot position of the marking laser is calculated. The actual spot diameter is slightly larger.
	Marking Shape	The arrangement of the character strings set at the time of character setting can be set. Straight Line: The string is arranged along the X axis. Tilt : The string is placed at the set angle to the X axis. Fan Like : The string is arranged light a fan around the center the user set.
	Current Date/Time Marking	The items (year, month, date, and time) set in accordance with the internal clock of the laser marker head is marked by updating them automatically.
	Expiry Date/Time Marking	The items (year, month, date, and time) set in accordance with the internal clock of the laser marker head is marked by updating them automatically.
	Counter Marking	The marking is executed with the trigger input after an increment by the set value.
	Lot Marking	The character string that is marked automatically according to the internal clock of the laser marker head.

Index

Index.....	213
------------	-----

Index

A

Abnormal Reception Response Data Format	175
Adjustment of Display Position	133
Adjustment of Laser Start/End Points	128
Adjustment of Marking Position	132
Adjustment of Marking Quality	129
Air Filter	191
Alarm Output	163
Ambient humidity	17
Ambient temperature	17
Appearance of Connector	157
Appendix	197
Appointment of laser safety manager	9
Arbitrary character string (code STR)	182

B

BACKUP	142
Basic I/O	164
battery	19
Before External Controlling Laser Marker Using I/O Connector	156
Before External Controlling Laser Marker Using RS-232C	166
Bold	119

C

CAD Condition	120
CAD file	121
Cautions in Handling	15
Cautions in Handling Laser Beam	6
Center of Marking	38
Center Position Indication	134
Character array	194
Character Code Table	198
Character Condition	115
Character Setting Screen	88
Character type	194
Check Connection	169
Clock	150
Command Data	173
Command Data Format	173
Communication Command and Function	180
Communication Data Format	173
Communication Port	151
Communication Sequence	177
Connecting Head and Power Supply BOX	40
Connecting Laser Marker	40
Connecting Laser Marker and Personal Computer	41
Connecting Sample	13
Connecting Sample (In case of operating laser marker standalone) 157	157
Construction of Main Screen	78
Construction of Manual	27
Construction Sample of Interlock System	14
Contamination of f-theta Lens	191
Control Through I/O Connector	156
Control with RS-232C	166
Counter current value (code CNT)	183
Counter Ending Output	163
Counter reset (code CTR)	183
Counter Reset Input	162

D

Delimiter	180
Description of Main Screen	76
Details of Commands	180

E

Edit	79
Environmental humidity	194
Environmental Setting	150
Environmental Setting Related to Laser Marker	150
Environmental Setting Related to PC	152
Environmental temperature	194

F

File	79
FILE LIST	142
File No./Error Code Display	10
File No./Error Code Display (Head display panel)	34
File number change (code FNO)	180
File Select Input (D0 to D6)	162
FILE TRANSMIT	140
Font	122
Font File	153
Frame Ground F.G.	35
Function Setting Screen	104
Functions for Safety Measures	10
Fuse	35

G

Guide Indication	134
Guide Laser Function	39

H

Handle	34
Head	34
Help	80

I

I/O Connector	13, 34, 157
I/O Connector Input Signal	162
I/O Connector Output Signal	163
Image Display Screen	130
Inlet	35
Input Circuit	160
Input Common	162
Input Connecting Sample	160
Input counter	96
Input current date	90
Input date function character	72
Input expiry date	93
Input lot	98
Input of Marking Character	89
Input optional character string	100
Input Rating	160
Input registration character	102
Input the character to be marked	49
Input the counter function character	60
Input the lot function character	64
Input/Output Operation	162
Installation Direction	37
Installation Method	36
Installation Space	38
Interlock Connector	12, 35

K

Key Switch	12, 35
------------------	--------

L		
Labels	11	
Laser Power Revise and Scan Speed Revise	123	
Laser power revise and scan speed revise	119	
Laser Radiation Indicator	10, 34	
Laser Radiation Stop Input	13, 162	
List of Commands	180	
M		
Magnification	131	
Magnification Method	131	
Main Power Indicator	35	
Maintenance	191	
Mark Current Date	71	
Mark Lot No.	62	
Marking Condition	110	
Marking File	82	
Marking Operation and Command Transfer	179	
Marking Pitch	127	
Menu Function	79	
Mirror inversion	112	
Mode	80	
N		
New Creation	83	
O		
Offset	113	
onnecting Sample of External Control Device	168	
Operation at Interlock Input	14	
Operation Procedure Using External Control	43	
Operation Related to Counter	165	
Operation Sample Using External Control Device	42	
Outer Dimensional Drawing	195	
Output Circuit	161	
Output Common	163	
Output Connecting Sample	161	
Output Rating	161	
Output Rating and Output Circuit	161	
P		
Path of laser beam	9	
PC Control Mode	146	
Perform test marking from PC in PC control mode	54	
Power Connector	34, 35	
Power Supply BOX	12	
Power Supply Display	12	
Power Supply for External Device +12V (+12V)	163	
Preface	2	
Preparation	31	
Preparation of Laser Marker Operation	47	
Procedure from Laser Marker Setting to Test Marking	49	
Protective clothing	9	
Protective enclosure	8	
R		
Radiation direction of laser beam	9	
Radiation Nozzle of Laser and Guide Laser	34	
Readable DXF File	207	
Readout Response Data Forma	176	
Reception Timeout	177	
Registration File	83	
Registration File and Marking File	86	
Remote Mode	144	
Response Data	174	
RESTORE	143	
rror Display and I/O Connector Output	189	
RS-232C Connector	34, 167	
S		
Safety Protection Measures	8	
Sample of Control	170	
T		
Termination of laser beam	9	
Test Marking	138	
Tilt	117	
Timing Chart	164	
Tool Button Function	81	
Trademarks	4	
Trigger Input	162	
Troubleshooting	187	
U		
USB Connector	34	
Useful Function for Installation	39	
Using Communication Control and I/O Connector (25-pin Connector) Together	179	
V		
View	79	
W		
Warranty of Product	4	
Wearing protective goggles	8	
Weight	194	
Window	80	
Work distance	194	
Z		
Zoom-in/out buttons and magnification list box	131	

Panasonic Industrial Devices SUNX Co., Ltd.

■ Overseas Sales Division (Head Office): 2431-1 Ushiyama-cho, Kasugai-shi, Aichi, 486-0901, Japan

■ Telephone: +81-568-33-7861 ■ Facsimile: +81-568-33-8591

panasonic.net/id/pidsx/global

About our sales network, please visit our website.

© Panasonic Industrial Devices SUNX Co., Ltd. 2003 - 2021

March, 2021

9000-0066-37V