

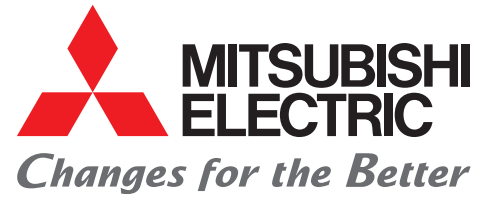

for a greener tomorrow



# Mitsubishi SCADA Software

*e-Factory*

MC Works64



# MC Works<sup>64</sup>

The Next Generation in Automation Software

# GLOBAL IMPACT OF MITSUBISHI ELECTRIC



Through Mitsubishi Electric's vision, "Changes for the Better" are possible for a brighter future.

## ***Changes for the Better***

We bring together the best minds to create the best technologies. At Mitsubishi Electric, we understand that technology is the driving force of change in our lives. By bringing greater comfort to daily life, maximising the efficiency of businesses and keeping things running across society, we integrate technology and innovation to bring changes for the better.

Mitsubishi Electric is involved in many areas including the following

### **Energy and Electric Systems**

A wide range of power and electrical products from generators to large-scale displays.

### **Electronic Devices**

A wide portfolio of cutting-edge semiconductor devices for systems and products.

### **Home Appliance**

Dependable consumer products like air conditioners and home entertainment systems.

### **Information and Communication Systems**

Commercial and consumer-centric equipment, products and systems.

### **Industrial Automation Systems**

Maximising productivity and efficiency with cutting-edge automation technology.

Mitsubishi Electric PA integrated solution

# iQ MELViz PlantSuite

iQ PlantSuite integrates the high-performance SCADA into the factory automation products Mitsubishi Electric proudly presents to the world. Mitsubishi Electric proposes iQ PlantSuite, the process automation (PA) integration solution for monitoring and control.

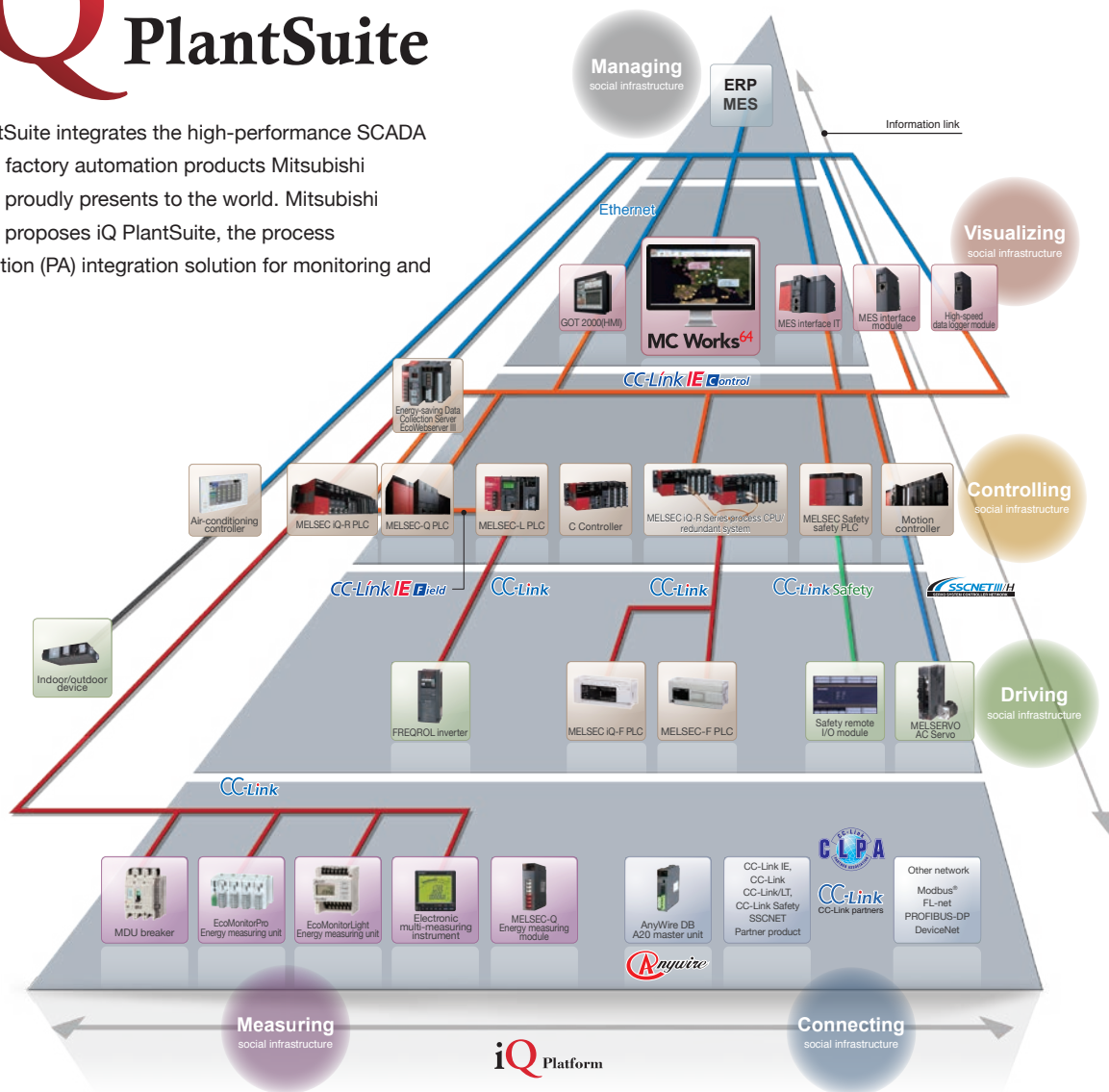

## OVERVIEW

|                        |    |
|------------------------|----|
| What is MC Works64?    | 4  |
| Constructing a display | 8  |
| Constructing a system  | 14 |
| Advanced functions     | 19 |
| Options                | 24 |
| Solutions              | 26 |
| Product List           | 34 |
| Support                | 40 |

The Next Generation in Automation Software

# MC Works<sup>64</sup>

e-F@ctory's SCADA software

Create an advanced, integrated monitoring system for FA equipment.

## MC Works<sup>64</sup> Server

### - Basic function

|                         |                                    |
|-------------------------|------------------------------------|
| 2D and 3D graphics      | GraphWorX64                        |
| Table format display    | GridWorX64                         |
| Script                  | ScriptWorX64                       |
| Alarm & event           | AlarmWorX64                        |
| Trend                   | TrendWorX64                        |
| Project management tool | Workbench<br>(Classic/-SL/Desktop) |

### Optional

|                 |                 |
|-----------------|-----------------|
| Form            | ReportWorX Lite |
| Data conversion | BridgeWorX Lite |

### - Advanced function

|                                  |                      |
|----------------------------------|----------------------|
| Design support tool              | MC AppBuilder        |
| Schedule management              | ScheduleWorX64       |
| Map information                  | EarthWorX64          |
| High-speed data collection       | MC Historian Express |
| Message notification             | AlertWorX            |
| Recipe management                | RecipeWorX           |
| Personalised monitoring displays | KPIWorX              |

### Optional

|                                      |                |
|--------------------------------------|----------------|
| High-speed, reliable data collection | MC Historian   |
| Energy monitoring                    | AX Energy      |
| Preventive maintenance               | AX Facility    |
| Quality control                      | AX Quality     |
| Message notification                 | MC Alarm64 MMX |

Compatible database  
Microsoft® SQL, Oracle®,  
MYSQL®, SAP,  
x64 OLE DB, x64 ODBC

## OPC server

### - Compatible model

DeviceXPLorer  
OPC server  
(Partner product)  
MX OPC Server  
Modbus® OPC server

### - Compatible communications

OPC UA,  
OPC DA, HDA, A&E  
BACnet™  
SNMP

Ethernet

Modbus®-compatible  
equipment

**e-F@ctory**

MELSEC

MELSEC



iQ-R Series



Q Series



L Series



iQ-F Series



F Series

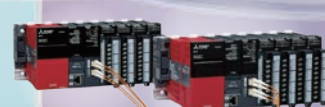

iQ-R Series

CC-Link IE Field

CC-Link IE Control

CC-Link

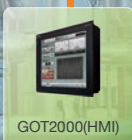

GOT2000(HMI)



FR-F800  
inverter



MR-J4  
AC servo

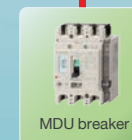

MDU breaker



EcoMonitorPro  
Energy measuring  
unit

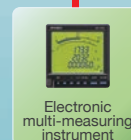

Electronic  
multi-measuring  
instrument



**MC Works<sup>64</sup> Client**  
 - Web monitoring  
 Optional  
 WebHMI Client\*  
 AX Portal\*

**MC Works<sup>64</sup> Client**  
 - Mobile monitoring  
 Optional  
 MC Mobile\*



Internet/  
intranet

3G/4G

\* : This function is installed on a server.

BACnet™-compatible equipment

redundant system

Q Series



The Next Generation in Automation Software

# MC Works<sup>64</sup>

Mitsubishi SCADA MC Works64 provides a highly-functional monitoring control system together with rich factory automation products.

MC Works64 provides the solutions for a variety of the needs in monitoring control.

## Enhancement of visibility and operability

### Improve the aesthetics and usability of your monitoring control

It may be difficult to effectively represent equipment monitoring using only 2D graphics. On the other hand, 3D graphics can enhance the visibility with its stereoscopic displays. 3D graphics allow you to have monitor views from various angles. This enables you to know the condition of equipment quickly and accurately, have instinctive monitoring views and make intuitive control.



## Enhancement of reliability

### Construct a highly reliable system that continues operation even during problematic times

MC Works64 enables you to construct redundant server systems and server-and-client systems. It is possible to utilize two servers, a control server and a standby server, to enhance the reliability of the system and to reduce the communication load on the network. It is possible to embody a configuration suitable for the system size, from a stand-alone system to a large-scale system.

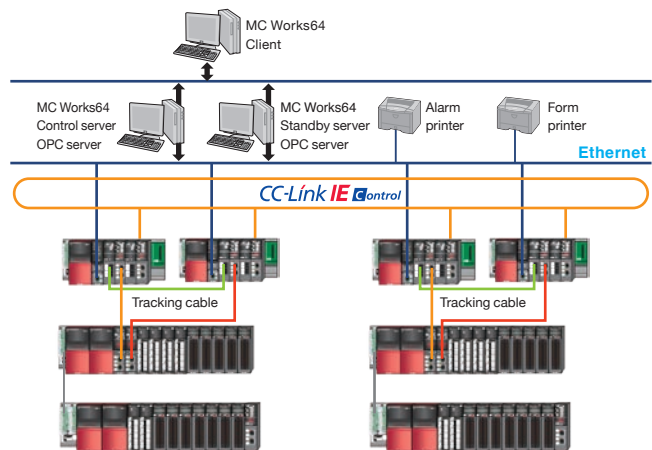

## Reducing engineering labor

### Make efficient use of preset equipment lists to construct graphics or programs

Various equipment lists are available to automatically generate graphics, programs, and OPC tag settings. The design support tool prevents incorrect tag settings, thus enhancing the design quality. Standard templates facilitate system configuration.

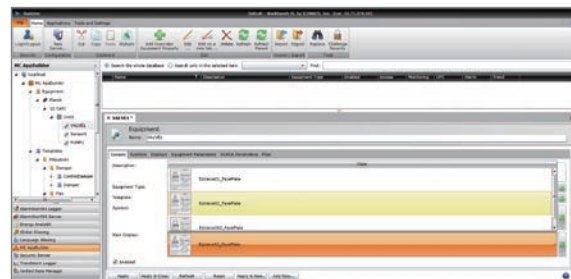



## Visualizing energy

### Save energy and reduce costs across the entire plant and improve production efficiency

By monitoring energy consumption, energy use can be reduced over time.

Energy consumption can be visualized through the integration of Mitsubishi Electric's energy measurement equipment and AX Energy; an energy analysis and visualization tool.

The lineup of Mitsubishi Electric's energy-saving equipment, that includes the inverter with enhanced motor control, will reduce energy consumption at your plant.



## Preventive maintenance

### Use the collected equipment data to provide preventative maintenance

Mitsubishi Electric's MES interface module can be used to collect information on production control. AX Facility can then display and analyze the diagnosis and equipment failure information.

These products automatically collect the information on the condition of equipment from a large amount of data, using it for the improvement of: the availability factor, preventive maintenance, fault prediction etc.

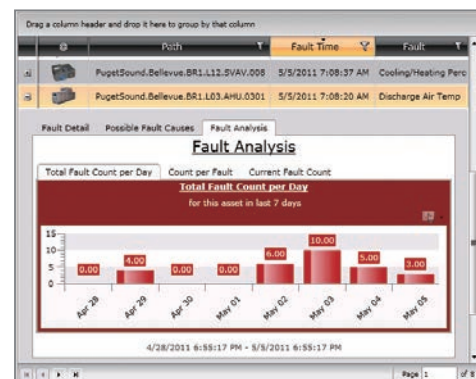

# Constructing a display

(Compatible with 3D graphics)

MC Works<sup>64</sup>

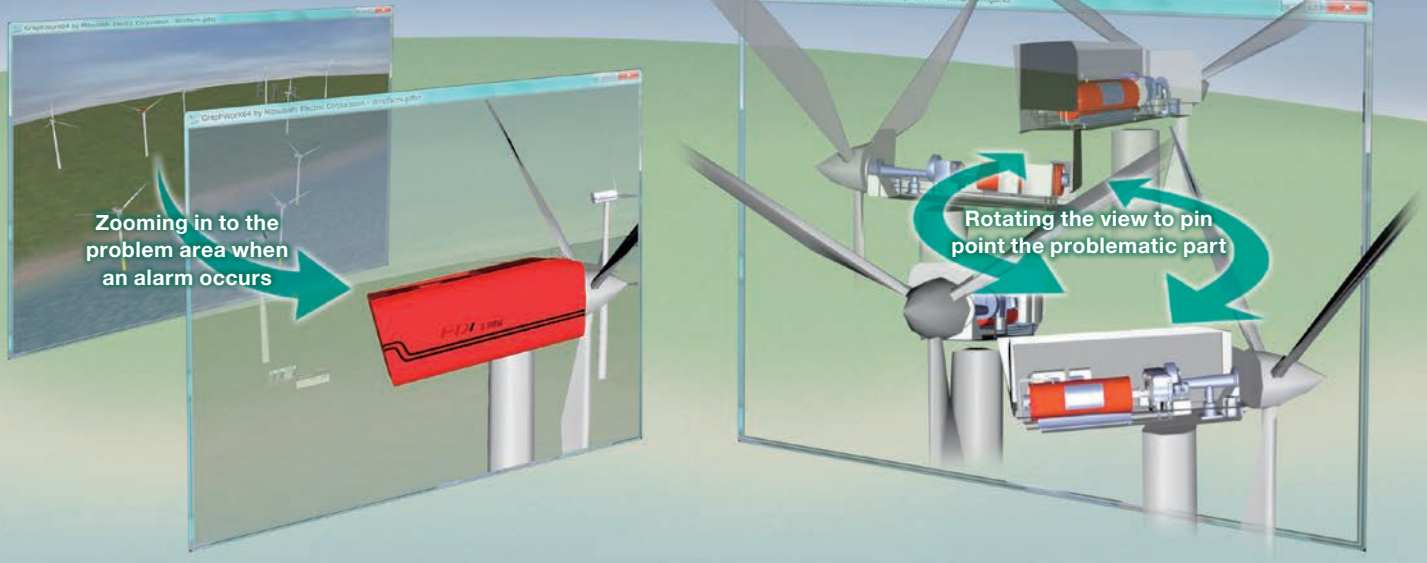

Multi-monitor screen display



Multi-view screen display

## Enhancing the visibility

### Multi-monitoring and multi-view screen display

This view satisfies the needs for simultaneous monitoring of multiple types of data and pictures brought by a highly functional system.

This multi-monitor display shows graphics, alarms, trends, camera views, and more over several monitors, enabling simultaneous monitoring. (You can use six monitors at the maximum.)

In the multi-view screen display, you can use one monitor to view two or more windows further improved monitoring. (You can view four windows at the maximum.)

## Enhancing the monitoring function

### Video monitoring | GraphWorX64

You can monitor the video images from CCTV on a screen. As you monitor graphics at the same time, the system operation will be secure and safe.





### Enhancing visibility

#### 2D and 3D graphics | GraphWorX64

You can create high definition 2D and 3D graphics. It may be difficult to effectively represent equipment monitoring using only 2D graphics. On the other hand, 3D graphics can enhance the visibility with their stereoscopic displays. You can control enlargement, reduction, rotation, and parallel movement of 3D graphics to monitor anything; from the facility as a whole to individual device details. When an alarm occurs, you can zoom in to the problematic part of the device. Thus, you do not need to move around from a screen display to another screen display, monitoring the facility without any interruption thanks to the parallel movement. You can use 2D graphics for a real-time screen display to view the condition of a device, operation and measurement data. You can import 2D and 3D CAD data etc. to create graphics.

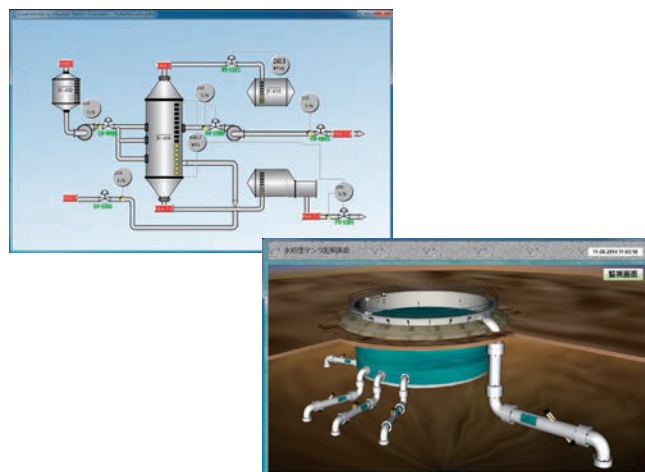

### Enhancing visibility/reducing symbol design time

#### Symbol Library | GraphWorX64

A set of pre-made symbols are available, known as the Symbol Library, which can reduce time spent on creating graphics. Custom symbols can be created and registered to the Symbol Library. The Symbol Library has more than one thousand types of high definition 2D and 3D symbols which cover a variety of industries including water treatment, building management, food, chemicals, and more.

An animation function is also included. You can register a tag to a symbol to change colors and display numbers, reducing the labor for creating a script.

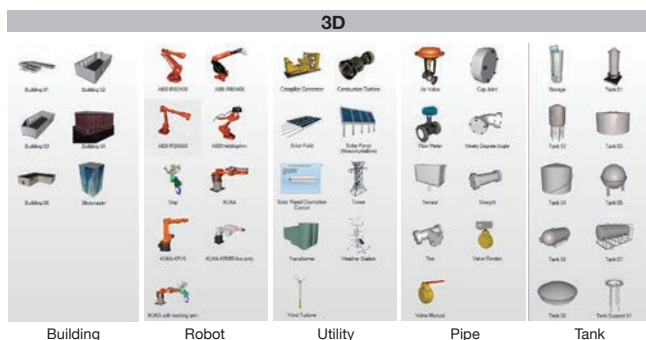
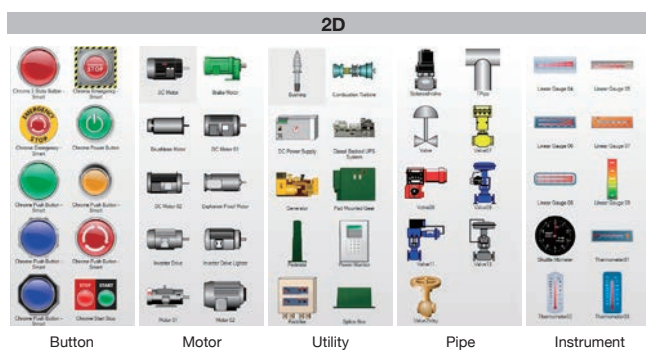

#### ■ Specifications of GraphWorX64

|                      |   |
|----------------------|---|
| <b>Screen</b>        |   |
| Size/resolution      | Unlimited   |
| Support              | Layer<br>Zoom<br>Declutter with zooming<br>Window [Menu on/off, scroll bar, option, move, resize]   |
| <b>2D shapes</b>     |   |
| 2D drawing           | Straight line, curve, arc, multiple straight lines, rectangle, ellipse, polygon, text, label  |
| 2D image             |   |
| Expansion            | JPG, JPE, JPEG, PNG, GIF, TIF, TIFF, JFX, BMP, ICO, WMF, EMF, SVG, SVGZ, DWG, DXF   |
| Reference            | JPG, JPE, JPEG, PNG, GIF, TIF, TIFF, JFX, BMP, ICO, WMF, EMF, SVG, SVGZ, DWG, DXF   |
| 2D advancement       | Shared keyword for updating symbols on multiple screens   |
| 2D symbol            | 1,500 or more   |
| <b>3D shapes</b>     |   |
| 3D drawing           | Cube, sphere, surface, polygon, torus, cone, column, terrain, pipe, comment   |
| 3D import            | AutoCAD® Binary (.dwg), XAML (.xaml), 3D Studio (.3ds), COLLADA (.dae), OBJ (.obj)  |
| 3D advancement       | Polygonal reduce - 3D symbol mesh size reduce   |
| 3D symbol            | 300 or more   |
| <b>Color</b>         |   |
| Fill                 | RGB, Gradients, image tile  |
| Line                 | RGB, Gradients, image tile  |
| <b>Effect/format</b> |   |
| General              | Opacity, inclination, drop shadow, brilliance, blur   |
| Object               | Line format, linewidth, line vertex, line joint   |
| Rectangle            | Roundness (X, Y)  |
| Ellipse              | Radius (X, Y)   |
| Polygon              | Vertex control  |
| <b>Dynamics</b>      |   |
| Text                 | Process point, data input, time/date  |
| Button               | Button, check box, radio button, display button   |
| Dimension            | Size, position, rotation  |
| Color                | Object fill color, object line color, disable, hide, text background color, text foreground color, text border color  |
| Selection            | State, range  |
| Selection control    | Window [Close a window.]<br>Navigation [Show in rear, show in front]<br>Screen [Refresh display, popup menu, object display setting, view setting]<br>Aliasing [Global alias setting, language setting, local alias setting]<br>Value [Write value, toggle value]<br>Application [Start application]<br>Script [Start script]<br>Database upload, start form (ReportWorX), start transaction (BridgeWorX) |
| Other                |   |
| Security             | Login/logout dialog   |
| <b>.NET Controls</b> |   |
| Module               | GraphWorX64, GridWorX64, AlarmWorX64, TrendWorX64, EarthWorX64, AX Energy   |
| Design               | Pipe, scale, smart tile   |
| Video                | Static protocol (WMV, AVI, MPEG, MOV, MP4)<br>Streaming protocol (HTTP, HTTPS, MS-WMSP (MMS and RTSP))  |
| GEO-SCADA            | Smart pin, push pin (EarthWorX64)   |

### Enhancing visibility/reducing the labor for illustration

**CAD compatible** | **GridWorX64**

You can use 2D and 3D preset objects to quickly create displays and reduce engineering time. You can import AutoCAD® data and other existing data to construct a screen display.

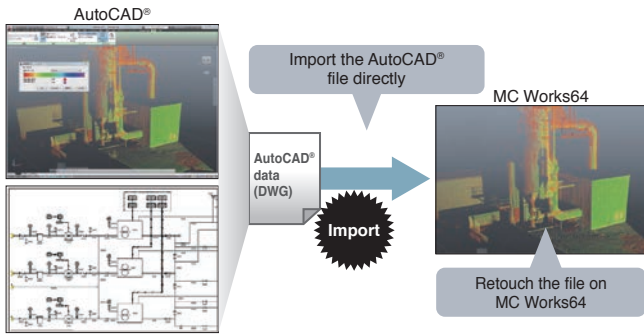

### Enhancing visibility/reducing the labor for illustration

**Table format displays** | **GridWorX64**

When you monitor a large amount of data, it may be effective to organize the values on a grid in the spreadsheet format. You can use GridWorX64 to realize the visualization of data by customizing data sets and using a large-size grid. During design, you can easily set data sources in a grid, reducing the scripting for illustration. During runtime, an operator can sort, group, and filter data in real time for monitoring. As a result of sorting, an operator may find some critical data. By grouping data, an operator can quickly organize the data for improved visualization.

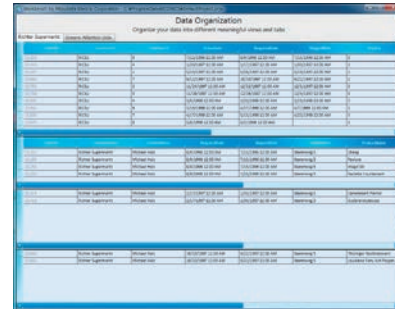

#### ■ Specifications of GridWorX64

|                 |  |
|-----------------|--|
| Refresh         | Manual<br>Automatic  |
| Maximum value   | Row [Unlimited (One million rows or less recommended)]<br>Column [Unlimited (One hundred columns or less recommended)]   |
| Variable format | Background, Foreground, Font Size, Font Weight, Font Family, Font Style  |
| Data format     | Boolean value, character string, time and date, 16-bit integer, 32-bit integer, 64-bit integer, double unsigned 16-bit integer, unsigned 32-bit integer, unsigned 64-bit integer, OPC UA status code |
| Support         | Filter<br>Grouping<br>Sort<br>Read out [Readable point only]<br>Write in [Writable point only]   |

### Reducing the labor for illustration

**Script** | **ScriptWorX64**

This is a server application to execute VBA (Visual Basic® for Applications) scripts. You can set time triggers, data triggers, and other various conditions to execute scripts. Watchdog monitoring, an automatic recovery function and an execution queue function are available. These enable easy implementation of complicated periodical processes and event-dependent processes.

#### An example of the process to store production achievement data

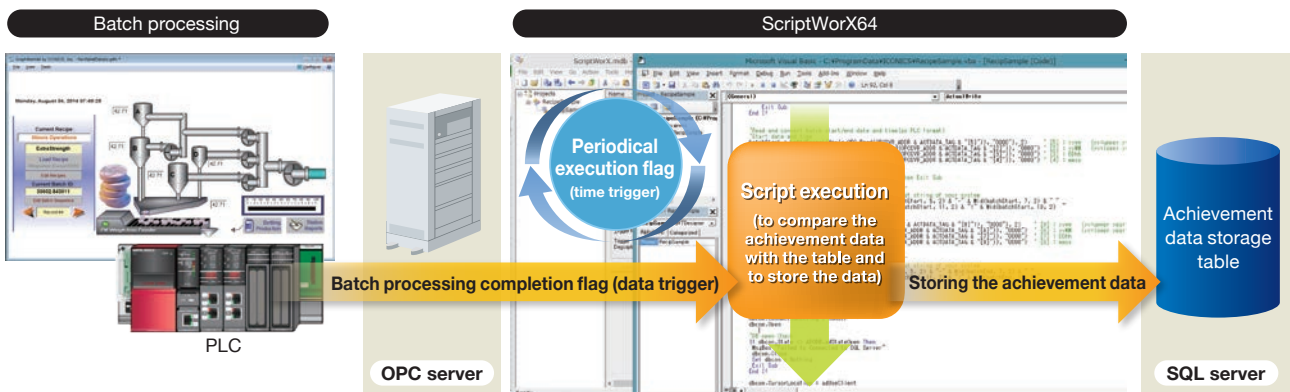

Enhancing visibility/a variety of screen display formats

Alarm & event AlarmWorX64

Quickly attend to any situation by monitoring alarm tag data and issuing alarm notices.

In addition, the software collects alarm information from the alarm server and stores it in a database; logging it in the alarm history. Alarm controls can be used to display data real-time and historical alarm information on the graphics. An operator can filter alarm information during operation to view only necessary data. By altering the conditions to match the user's needs (e.g. sort and combine alarm charts) alarms can be analyzed efficiently.

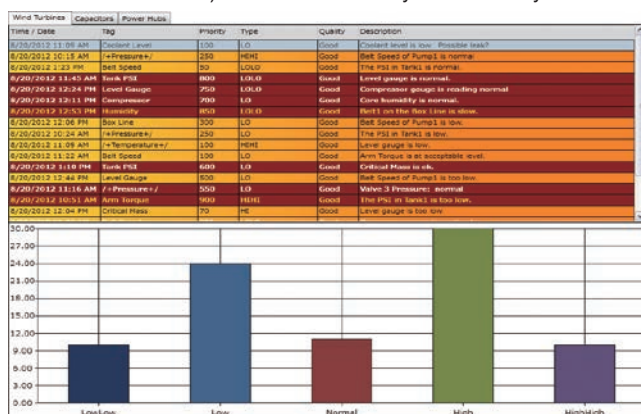

■ Specifications of AlarmWorX64

|                                   |  |
|-----------------------------------|--|
| <b>OPC connection</b>             |  |
| OPC UA                            | Client [A/E]   |
| OPC Classic                       | Server [A/E], Client [A/E]                           |
| <b>AlarmWorX64 Server</b>         |  |
| Basic alarm type                  | Limit, digital, deviation, rate of change            |
| Advanced alarm type               | Rate limit/trigger limit                             |
| Support                           |  |
|                                   | Alarm area   |
|                                   | Alarm template                                       |
|                                   | Relevant value                                       |
|                                   | Online change  |
| <b>AlarmWorX64 Logger</b>         |  |
| Logger type                       | Database   |
| Logger setting                    | Reservation type                                     |
| Support                           |  |
|                                   | Multi-setting  |
|                                   | Redundancy   |
|                                   | Database table management                            |
|                                   | Printer logging                                      |
|                                   | Conversion logging                                   |
| <b>AlarmWorX64 Viewer</b>         |  |
| Data type                         | Real-time, history, event (A/E, log alarm and event) |
| Integration                       | GraphWorX64  |
| Support                           |  |
|                                   | Multi-grid   |
|                                   | Multi-tab  |
|                                   | Custom format  |
|                                   | Filter   |
|                                   | Grouping   |
|                                   | Sort   |
| MC Alarm64 MMX (Optional Package) | E-mail Notifications for alarms                      |

Enhancing visibility/a variety of screen display formats

Trend TrendWorX64

It is also possible to view real-time and historical trend data.

Real-time data is collected directly from the OPC server and is shown as a real-time trend. On the other hand, historical data is stored in the database and logged as a trend history. The logged data will be shown as a historical trend. You can add trend graphs to graphic displays to supply trend data to operators alongside other important data.

You can view multiple data items in one trend display and can split or overlap a view/s. In addition, you can pause a trend display, add display data, and change a display scale.

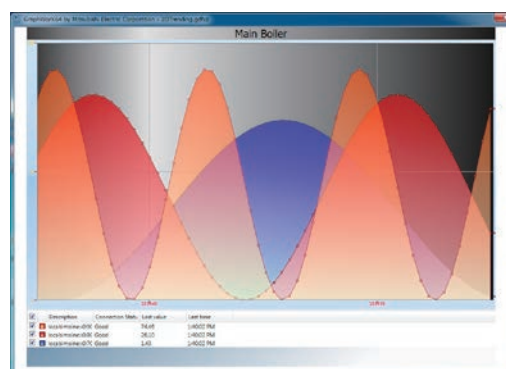

■ Specifications of TrendWorX64

|                           |  |
|---------------------------|--|
| <b>OPC connection</b>     |  |
| OPC UA                    | Client [DA, HDA]   |
| OPC Classic               | Client [DA, HDA]   |
| <b>TrendWorX64 Logger</b> |  |
| Logger type               | Database   |
| Logger setting            | Tag  |
| Max. capacity             | 5,000 tags (recommended)   |
| Support                   |  |
|                           | Multi-logging group  |
|                           | Multi-database group   |
|                           | Save and transfer  |
|                           | Start/stop status  |
|                           | Database table management  |
| <b>TrendWorX64 Viewer</b> |  |
| Data type                 | Real-time, history (DA, HDA)   |
| Integration               | GraphWorX64  |
| Trend count               | 250 or more (25 or less recommended for reliability)   |
| Time and rate             | Trend time, summary period, data collection rate, display refreshing rate, history refreshing rate |
| Time and date             |  |
|                           | UTC, Local   |
|                           | Time format [None, Long, Short, Custom (h, H, m, s, t)]  |
|                           | Date format [None, Long, Short, Custom (M, d, y)]  |
| Plot type                 |  |
|                           | Line [Time, Time spline, Step time, XY]  |
|                           | Area [Time area, Time spline area, Time step area]   |
|                           | Other [Bar, Histogram, Circle, Pie, SPC management chart]  |
| Pen type                  |  |
|                           | Line [Solid line, Broken line, Dotted line, Dotted-broken line, Custom]                            |
|                           | Marker [None, Circle, Square, Triangle]  |
|                           | Value format [Currency, Decimal, Exponent, Fixed decimal, General, Number, Percent, Hexadecimal]   |
|                           | Range [Automatic, Automatic scale, Fixed (Min., Max.)]   |
| Support                   |  |
|                           | Bad Quality marker   |
|                           | Multi-grid   |
|                           | Multi-tab  |
|                           | Multi-chart  |
|                           | Custom format  |
|                           | Trend stop   |
|                           | Alarm line   |
|                           | Ideal pen  |

## Enhancing maintenance performance

### Project management tool | Workbench (Classic/-SL/Desktop)

Workbench (Classic/-SL/Desktop) is a project management tool that allows a user to organize all of MC Works64's related products from a single location. These include a variety of applications including GraphWorX64, AlarmWorX64 and MC Historian.

Workbench-SL is a management tool based upon Microsoft® Silverlight®. As this environment utilizes a web browser, it is possible to create displays and organize a project on machines that do not have MC Works64 installed.

\* A separate development license for the client is required.

Workbench Desktop is the latest addition to the MC Works64 project management family. It boasts ease of use through an easy to navigate project tree and drag-and-drop functionality. This allows for the intuitive, visual construction of an MC Works64 project.

By supporting both local and remote access, the Workbench series of applications provide a high amount of freedom for developing systems and displays.

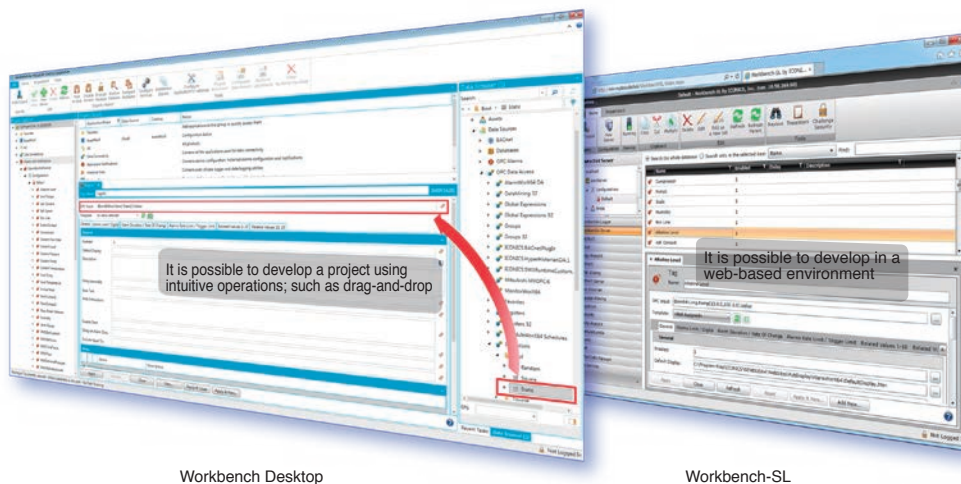

Workbench Desktop

Workbench-SL

## Enhancing visibility/global application

### Multi-language display | Workbench (Classic/-SL/Desktop)

#### ● Switching display language

During runtime it is possible to change the current display language.

This global function supports a wide variety of languages including: English, Japanese, Chinese, Spanish etc.

#### ● Language Pack

The default language for the Workbench (Classic / -SL/Desktop) environment is English.

However, after installing an additional language pack it is possible to view the configuration environment in Japanese or Chinese.



Function linkage

Form ReportWorX Lite (optional package)

Data from databases can be extracted and used to create various types of reports including: daily, weekly, monthly and yearly reports. This software can create a form in the Microsoft® Excel® format and can also save files in HTML and PDF formats. In addition, you can register multiple form format templates. MC Works64 includes a simplified version of this software called ReportWorX Express that supports OPC, TrendWorX64 Logger Database, MC Historian, AlarmWorX64 Logger Database, Energy Star and AX Quality. Among them, ReportWorX Lite (optional package) is recommended. ReportWorX Lite can create forms in Japanese, but its menu environment supports English only.

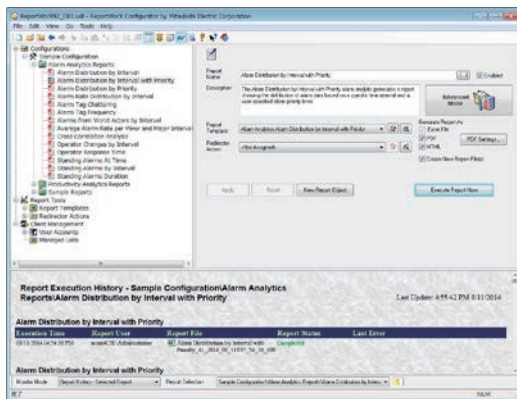

Setting screen

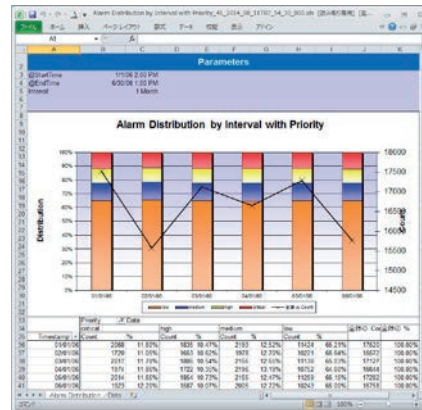

An example of forms

Recipe management RecipeWorX

RecipeWorX is a tool that allows for the easy management of ingredients and recipe lists. You can specify multiple parameters at once in a recipe list including; defining the ingredients, mixing time, processing time etc. New parameter values can be downloaded to the device to update a working recipe or current values can be uploaded from the device and displayed on screen. By combining this with ScheduleWorX64 (see P21), it is also possible to create schedules that change the current recipe automatically.

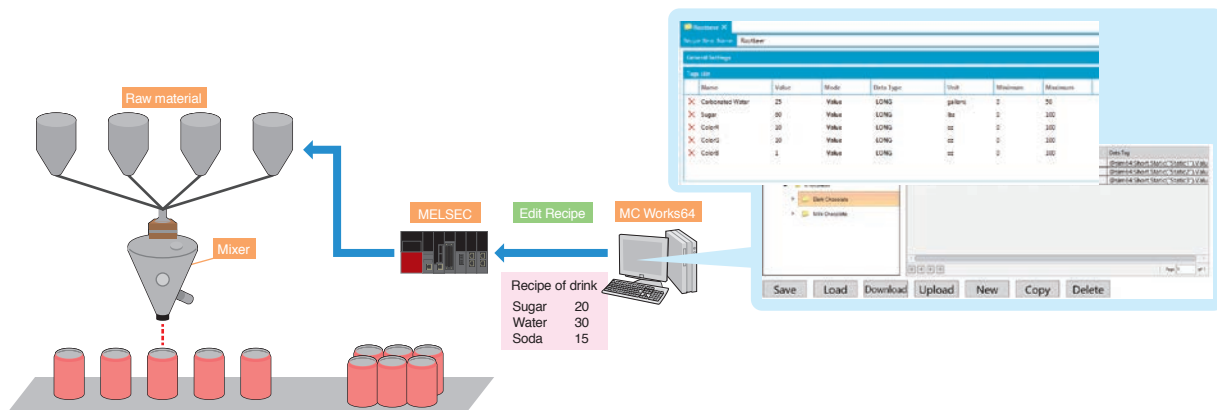

# Constructing a system

MC Works<sup>64</sup>



## Enhancement of reliability

### Server & client

MC Works64 supports server and client systems and redundancy. You can use two servers to configure a control server and a standby server, enhancing the reliability of a system and reducing the communication load on a network. MC Works64 can be configured to suitably match the needs of the system; be it a standalone or large scale system.

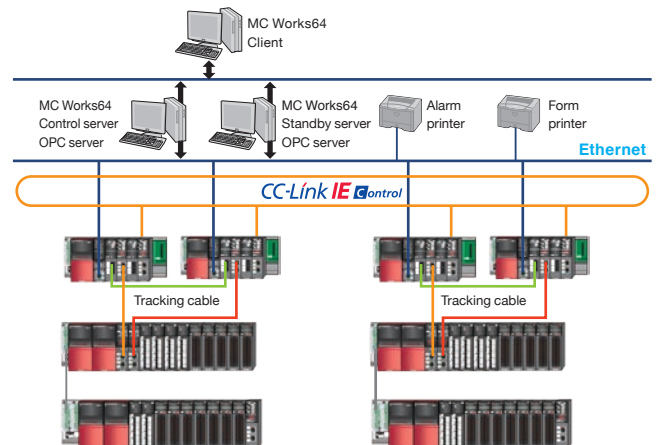

## Compatibility with Internet environments

### Web monitoring | WebHMI (optional package)

WebHMI uses your MC Works64 server as a web server. This allows operators to monitor and manipulate data over the Internet or Intranets. Almost all of the functions available in MC Works64 can be used in any client type.

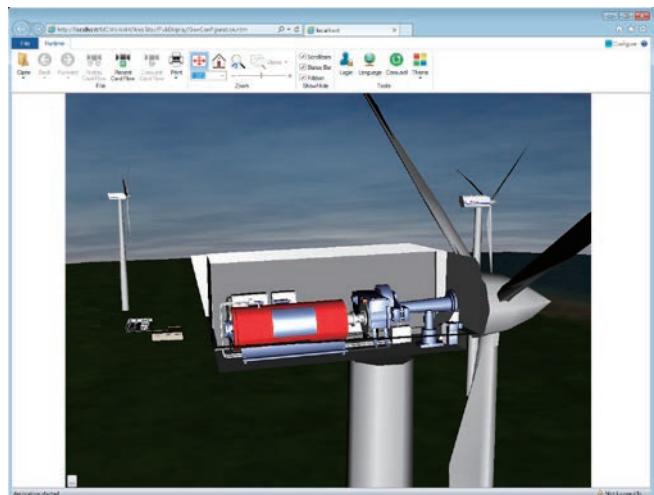

**Compatibility with Internet environments**

**Mobile monitoring** | MC Mobile (optional package)

MC Mobile is the mobile software that monitors important applications of a building or a plant. It is easy to set up and use MC Mobile efficiently. The user can have access to, and monitor, important data anytime, anywhere and from any terminal. The manager, the engineer, the maintenance worker and the operator can: access and monitor data in real-time, view data on alarms, trends, energy, quality, production information etc. MC Works64 supports server and client systems and redundancy. MC Mobile is compatible with mobile terminals using the following technologies; Microsoft® Windows Phone® and Surface®, Apple® iPhone® and iPad®, Android® phones and tablets, or HTML5.



**MELSOFT MC Mobile (application)**

MC Mobile is a client application for use with mobile devices. This dedicated application optimizes the displays to match the device that is being used. Available for compatible OS versions of iOS®, Android®, Windows® and can be downloaded and installed from the App Store®, Google Play® or the Windows Store.

Supported versions : Android® 4.0 or higher, iOS® 7.0 or later, iPhone®, iPad®, iPod Touch®, Windows Phone® 8.1, Windows® 8.1, 10 and 10Mobile.

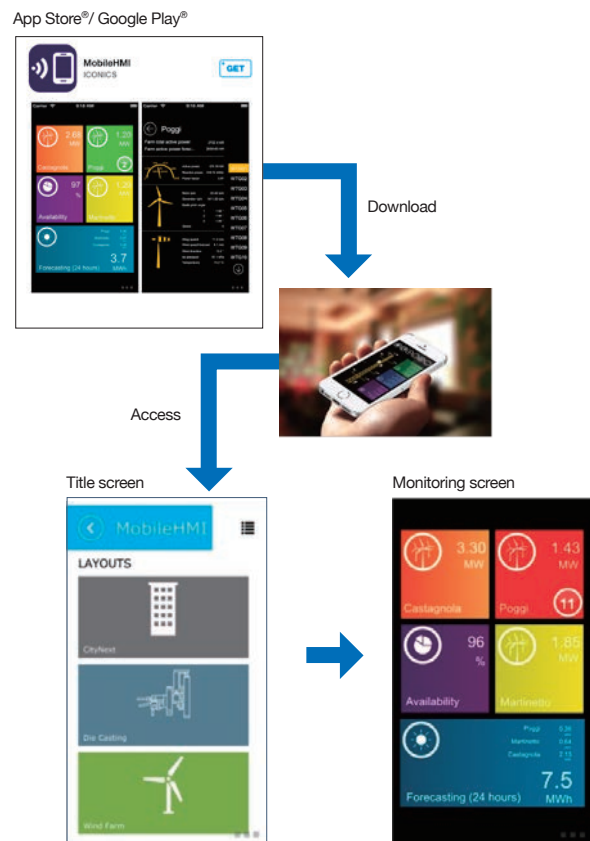

**Inter-functional linkage**

**Database**

MC Works64 is compatible with SQL, SAP, MySQL®, OLE DB, ODBC and other databases. MC Works64 is bundled with SQL Server® 2014 Express (English version).

## Inter-functional linkage

Data conversion | BridgeWorx Lite (optional)

BridgeWorX integrates information from different data sources and can transfer data to different target systems. BridgeWorX realizes the data transfer between the programmable controller on a production site and the SQL server in an MES system and the data transfer among ERP applications. BridgeWorX has a transaction diagram that enables you to set up data transfer. You do not need any knowledge about programming to set up the transaction diagram, simply drag-and-drop and use the help of a wizard to supply the necessary information.

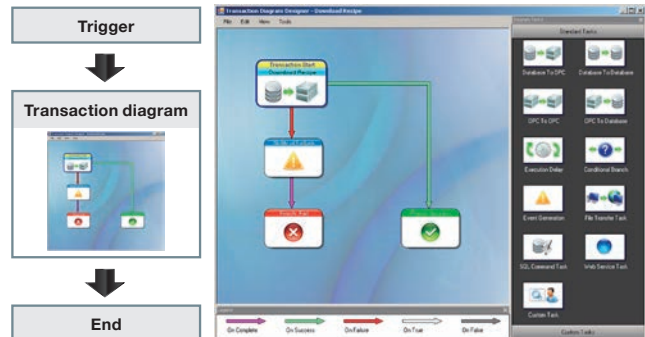

## Inter-functional linkage

Anti-virus software | Partner product

### McAfee® Application Control

McAfee® Application Control provides means for efficiently blocking malicious applications on servers, desktops, and integrated equipment. Different from simple white listing, Application Control uses a dynamic trust model, which saves you the troublesome labor usually required to update the list of trusted applications.

#### Perfect protection from unfavorable applications

Application Control expands the applicable scope to Java®, ActiveX® Controls, scripts, batch files and dedicated codes, enhancing the controllability of application components.

#### A sure protection of integrated systems and legacy systems

Application Control has such compact designing that it is applied to kiosk terminals, POS terminals, and other dedicated devices, operating with a RAM less than 10 MB and a minimum CPU. Its unique protection layer is expanded to Microsoft® Windows NT®, Windows® 2000 system and other legacy systems.

#### Simplifying patch application processes that can be troublesome

McAfee® Application Control enables you to temporarily delay a patch application until a regular patch application cycle. Even in a case where you worry about some vulnerabilities that do not have correction patches released, white listing can block such programs that make use of those vulnerabilities, thus allowing you can cope with them.

#### Centralized integration management

You can use McAfee® ePolicy Orchestrator (ePO) to optimize and simplify management processes. ePO enables you to use a sole centralized management console to monitor and control all security functions.

#### Inquiry

McAfee Embedded Solution Sales Division  
E-mail: MFE\_JPN\_BD@McAfee.com





## Enhancing connectivity

### Connection to a PLC and other equipment

MC Works64 supports the connection for equipment including programmable controllers via OPC servers and other networks. MC Works64 can connect to the OPC servers that are compatible with OPC UA and OPC Classic (DA, HDA, A/E). An OPC server connects to a programmable controller by way of several types of network. It is recommended that a DeviceXPlorer OPC server (partner product) is applied.

In addition, when a programmable controller is connected by way of an MES interface, it is possible to directly connect to an SQL server with MC Works64 to read or write data.

### OPC server connection

#### MX OPC Server

Software that is able to communicate with the MELSEC PLC.

#### MX OPC UA Server

Supports OPC UA functionality.

Add MX OPC UA Server

- Monitor and operate the equipment with OPC UA
- Support the auto-generation for the Setting of OPC UA Server in MC AppBuilder

#### DNP3.0 Support

Support for the DNP3.0 protocol in MX OPC Server

- Monitor and operate the equipment for DNP3.0
- [DNP3.0/Open communication protocol that is used in power and water supply facilities]

#### MELSEC iQ-R Series Process CPU, MELSEC iQ-F Series

Enhancement of Support H/W in MX OPC Server

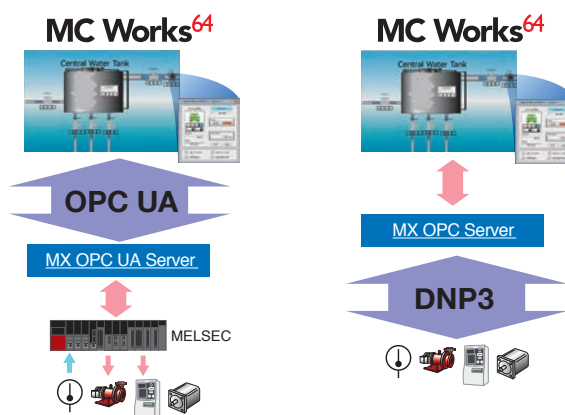

## Partner product

### DeviceXPlorer OPC Server

DeviceXPlorer OPC Server is the communication software that is compatible with MELSEC-Q Series, C Controller, Motion Controller, and GOT (HMI).

This software can use Ethernet, CC-Link and a variety of types of network to access production information.

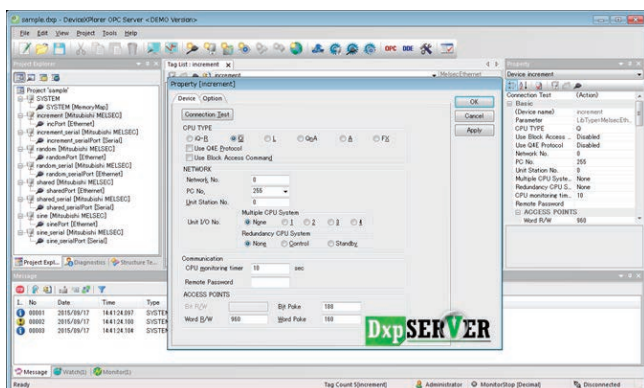

#### Compatible models

MELSEC iQ-R Series, iQ-F Series, Q Series, L Series, QnA Series, A Series, FX Series, GOT, Mitsubishi CNC, EcoWebServer III, E-Energy, EcoMonitor, M5CM

#### Compatible networks

Ethernet, serial, CC-Link, CC-Link IE, MELSECNET/H

#### Supported regions

Japan, China, Asia (other than Japan and China), Europe, North America, South and Central America, Africa

## Takebishi Corporation

### Inquiry

29, Mameda-cho, Nishi-kyogoku, Ukyo-ku, Kyoto 615-8501, Japan  
 TEL: +81-75-325-2171  
 E-mail: fa-support@takebishi.co.jp  
 URL: http://www.faweb.net/

Connection to the MES interface module

MELSEC iQ-R/MELSEC-Q MES interface



You do not need a gateway or a communication program for a direct connection between a programmable controller and MES.

- To store and control a variety of information in a plant involving production plans, quality, energy, and more on a seamless network
- To use a field network to collect detailed information up to end terminals
- To use an open network to simply gather information on the facility using a third-party's programmable controller for a machine tool

Connection to other networks

BACnet™ and SNMP are both supported.

You can use BACnet™ to connect a BACnet™-compatible device and utilize it in an MC Works64 server.

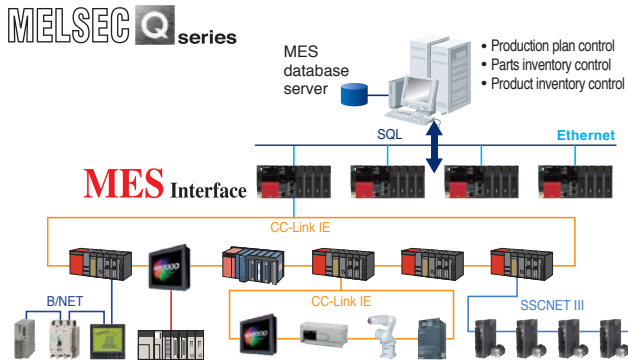
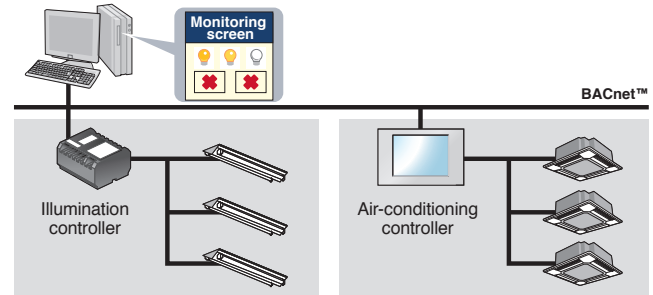

# Advanced functions

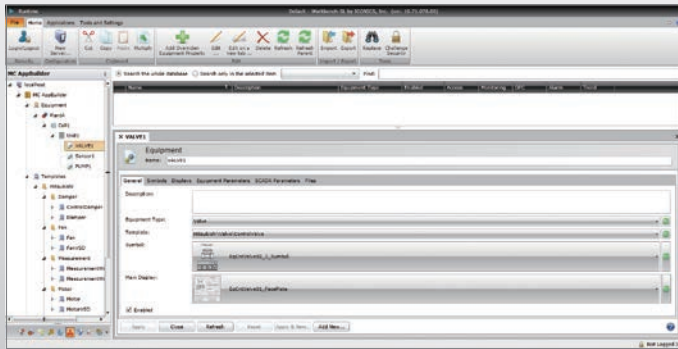

## MC AppBuilder

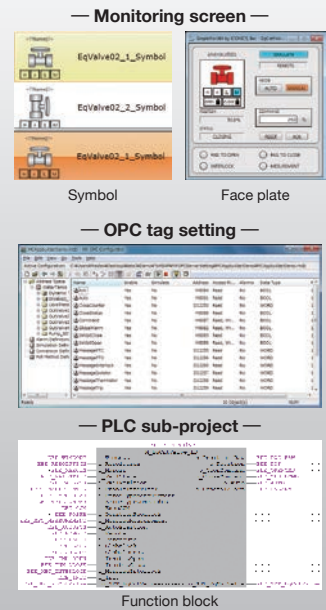

Constructing a display  
Constructing a system  
Advanced functions

Options

Solutions

Product list

**Design support / GX Works2 / GX Works3 linkage**  
×  
**MC AppBuilder**

### What is MC AppBuilder?

MC AppBuilder is an engineering support tool that enables you to easily construct a plant system where MC Works64 and a Mitsubishi programmable controllers are used. MC AppBuilder is bundled with MC Works64 as standard.

### Automatically generating a monitoring screen, a PLC project and setting tags

MC AppBuilder automatically generates a monitoring screen (including symbol parts and face plate parts), OPC tag settings (including alarms and trend settings) and a PLC project (including PLC programs and label definitions). This automatic generation makes your designing easy, reducing the labor for the registration of tag settings. In addition, this function enhances the affinity with Mitsubishi Electric's automation equipment.

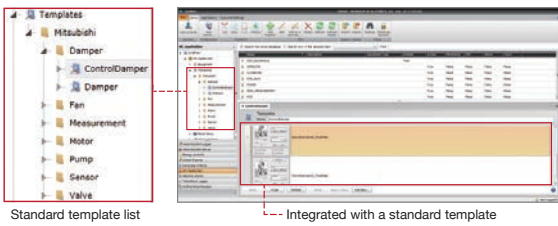

### Using templates\* to reduce the labor for designing

You can gather the common design details for each type of equipment into a template that can be saved into the Symbol Library. You can assign an applicable template to a piece of equipment in the system tree, thus reducing design labor time.

Templates are not only provided by the manufacturer but also registered, and reused, by the customers from their own know-how.

\* Templates include symbols, face plates, and other graphic parts information as well as function blocks and other program information and each type of interface information (alarms and trend settings).

### Easy renewal of a system

It is easy to add and remove equipment from a system. When renewing a system, this reduces design labor.

### Simplifying the monitoring of energy measurement equipment

In MC AppBuilder you can import measurement point information created by the EcoWebServer III setting tool, Mitsubishi Electric's energy-saving data collection server, thus automatically generating a monitoring screen and OPC tag settings. This link with the EcoWebServer III setting tool reduces the labor required to create these settings.

### A tree format for the managing the system configuration

You can import an equipment list (in CSV format) that is created with CAD or Microsoft® Visio® to construct a system tree showing the equipment configuration of a plant. This intuitive tree format enables you to take management of the equipment configuration of a plant.

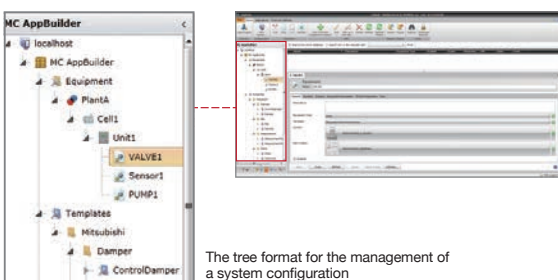

### Easy creation of GOT(HMI) screen displays

Symbols and face plates are integrated for creating GOT, contributing to the reduction of the labor for creating GOT screen displays. See the list of template libraries (see P20) for the GOT screen displays integrated with MC Works64.

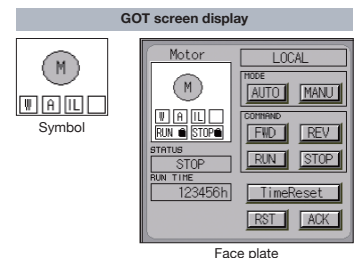

## List of template libraries

| Name                              | Description  | Component |            |                | Compatibility with GOT screen display <sup>*1</sup> |
|-----------------------------------|--|-----------|------------|----------------|---|
|                                   |  | Symbol    | Face plate | Function block |   |
| Sensor                            | Displays the input status from a connected sensor. Specify any of Status, Warning, and Alarm as a type of notification of an input status.   | ●         | ●          | ●              | ●   |
| Fan                               | Controls ON/OFF switching of a fan. <sup>*2</sup>  | ●         | ●          | ●              | ●   |
| Motor                             | Controls ON/OFF switching of a motor. <sup>*2</sup>  | ●         | ●          | ●              | ●   |
| Pump                              | Controls ON/OFF switching of a pump. <sup>*2</sup>   | ●         | ●          | ●              | ●   |
| Valve                             | Controls Open/Close switching of a valve. <sup>*3</sup>  | ●         | ●          | ●              | ●   |
| Damper                            | Controls Open/Close switching of a damper. <sup>*3</sup>   | ●         | ●          | ●              | ●   |
| FanVSD                            | Specifies a fan speed to control ON/OFF switching.   | ●         | ●          | ●              | ●   |
| MotorVSD                          | Specifies a motor speed to control ON/OFF switching.   | ●         | ●          | ●              | ●   |
| PumpVSD                           | Specifies a pump speed to control ON/OFF switching.  | ●         | ●          | ●              | ●   |
| FanVSD WithCCLink                 | Uses CC-Link to specify a fan speed to control ON/OFF switching. Shows the power consumption of an inverter.   | ●         | ●          | ●              | ●   |
| MotorVSD WithCCLink               | Uses CC-Link to specify a motor speed to control ON/OFF switching. Shows the power consumption of an inverter.   | ●         | ●          | ●              | ●   |
| PumpVSD WithCCLink                | Uses CC-Link to specify a pump speed to control ON/OFF switching. Shows the power consumption of an inverter.  | ●         | ●          | ●              | ●   |
| ControlValve                      | Controls OPEN/CLOSE switching of a valve that can have the open/close status specified in the range from 0 to 100%.  | ●         | ●          | ●              | ●   |
| ControlDamper                     | Controls OPEN/CLOSE switching of a damper that can have the open/close status specified in the range from 0 to 100%.   | ●         | ●          | ●              | ●   |
| Measurement With4threshold        | Shows the status of a measured value depending on the predefined range from HH/H/LL. An alarm is issued with HH or higher or LL or lower. A warning is issued with H or higher or L or lower.  | ●         | ●          | ●              | ●   |
| Measurement With8threshold        | Shows the status of a measured value depending on the predefined range from HH/H/H2/H1/L1/L2/L/LL. An alarm is issued with HH or higher or LL or lower. A warning is issued with H or higher or L or lower. A status is issued with H1 or higher or L1 or lower. | ●         | ●          | ●              | ●   |
| Light Controller                  | Control ON/OFF switching of lights with a light controller.  | ●         | ●          | —              | —   |
| Air Conditioning Controller       | Control ON/OFF switching of air conditioners with a conditioning controller.   | ●         | ●          | —              | —   |
| Energy Measuring Module           | Shows measurement values from an energy measuring module (QE81WH, QE81WH4W, QE84WH, QE83WH4W).   | ●         | ●          | ●              | ●   |
| Insulation Monitor Module         | Shows measurement values from an insulation monitor module (QE82LG).   | ●         | ●          | ●              | ●   |
| PID                               | Controls PID. <sup>*4</sup>  | ●         | ●          | ●              | ●   |
| Converter ToEngineeringValue      | Executes a scale conversion of a value input from an analog module to output an engineering value.   | ●         | ●          | ●              | ●   |
| Converter FromEVForHighResolution | Executes a scale conversion of an input engineering value to output a value to an analog module.   | ●         | ●          | ●              | ●   |

| Name  | Description  | Component |            |                | Compatibility with GOT screen display <sup>*1</sup> |
|---|--|-----------|------------|----------------|---|
|   |  | Symbol    | Face plate | Function block |   |
| Converter FromEngineeringValue                    | Executes a scale conversion of an input engineering value to output a value to an analog module.                 | ●         | ●          | ●              | ●   |
| Converter FromEVForHighResolution                 | Executes a scale conversion of an input engineering value to output a value to an analog module.                 | ●         | ●          | ●              | ●   |
| HARTMonitor                                       | Collects, and shows, an analog value from equipment supporting the HART communication.                           | ●         | ●          | ●              | ●   |
| EnergyMeasurement WithCCLink                      | Shows a measurement value of a measurement module supporting CC-Link (an electronic multi-measuring instrument). | ●         | ●          | ●              | ●   |
| Q68ADV  | MELSEC-Q Series Analog input module (voltage input)  | —         | —          | ●              | —   |
| Q62AD_DGH<br>Q66AD_DG<br>Q68ADI                   | MELSEC-Q Series Analog input module (current input)  | —         | —          | ●              | —   |
| Q64AD<br>Q64ADH<br>Q64AD_GH<br>Q68AD_G            | MELSEC-Q Series Analog input module (voltage/current input)  | —         | —          | ●              | —   |
| Q68DAVN   | MELSEC-Q Series Analog output module (voltage output)  | —         | —          | ●              | —   |
| Q68DAIN   | MELSEC-Q Series Analog output module (current output)  | —         | —          | ●              | —   |
| Q62DAN<br>Q62DA_FG<br>Q64DAN<br>Q64DAH<br>Q66DA_G | MELSEC-Q Series Analog output module (voltage/current output)  | —         | —          | ●              | —   |
| Q64AD2DA  | MELSEC-Q Series Analog input/output module (voltage/current input/output)  | —         | —          | ●              | —   |
| Q68CT   | MELSEC-Q Series CT input module  | —         | —          | ●              | —   |
| Q64RD<br>Q64RD_G<br>Q68RD3_G                      | MELSEC-Q Series Temperature input module (resistance temperature detector)                                       | —         | —          | ●              | —   |
| Q64TD<br>Q64TDV_GH<br>Q68TD_G_H01<br>Q68TD_G_H02  | MELSEC-Q Series Temperature input module (thermocouple)  | —         | —          | ●              | —   |
| L60AD4<br>L60AD4_2GH                              | MELSEC-L Series Analog input module (voltage/current input)  | —         | —          | ●              | —   |
| L60DA4  | MELSEC-L Series Analog output module (voltage/current output)  | —         | —          | ●              | —   |
| L60AD2DA2   | MELSEC-L Series Analog input/output module (voltage/current output)  | —         | —          | ●              | —   |
| Measuring PointMonitor                            | Collects, and shows, the current value of a measurement point of EcoWebServer III via an OPC server.             | ●         | —          | —              | —   |

\*1: A GOT screen provides symbols and face plates and does not support automatic generation.  
 \*2: Speed is not controlled.  
 \*3: There is no function to specify the open/close status.  
 \*4: The PIDCONT instruction is supported.

### Example: Control Valve

1. Face plate      2. Symbol      3. Function block

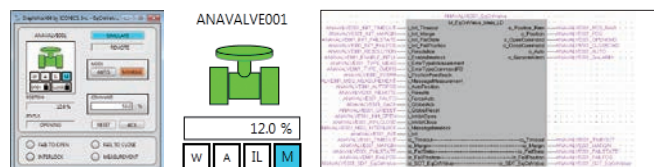

## Supported Equipment List

- MELSEC iQ-R Series CPU (including the CC-Link IE built-in model)
- MELSEC iQ-R Series Process CPU (including redundant configuration)
- MELSEC Q Series CPU (Basic model, high-performance model, universal model and universal model high-speed type)
- MELSEC Q Series Process CPU (Excluding universal model)
- MELSEC Q Series Redundant CPU
- MELSEC L Series CPU

## Schedule management

### ScheduleWorX64

You can follow a schedule to automatically change building lighting, air-conditioning, plant facility and so forth. By referring to a schedule you can set up tag values for daily, weekly, and monthly schedule management.

#### ■ Specification of ScheduleWorX64

| Schedule type |                                     |
|---------------|-------------------------------------|
| Periodical    | General, weekly, holidays, seasonal |
| One time      | Override, exceptional               |
| View          | Day, week, month, timeline          |
| Support       |                                     |
|               | Outlook® format                     |
|               | Remote setting                      |
|               | Live monitor mode                   |
|               | Security                            |
|               | Manual override                     |

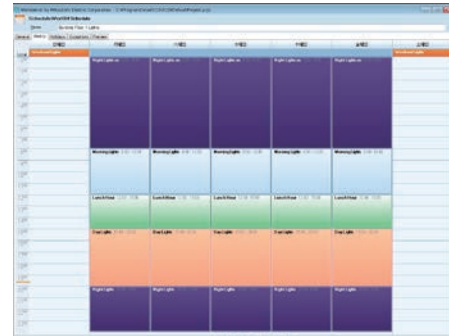

## Wide area monitoring

### EarthWorX64

You can use Bing Maps and other map systems via the Internet to display geographical information for wide area monitoring. You can monitor business bases and plants distributed around the world on a single map. In addition, when you use a pin, you can view detailed information and alarm statuses. You can also use GPS data for monitoring.

#### ■ Specifications of EarthWorX64

| Map                  |  |
|----------------------|--|
| Bing®                | Road (Shade, No Shade), Hybrid, Aerial   |
| Esri®                | Imagery, World Boundaries, Streets, Topographic, Canvas, National Geographic, Oceans |
| Google®              | Roadmap, Satellite, Terrain, Hybrid  |
| OGC WMS              | Custom   |
| EarthWorX64 Viewer   |  |
| Zoom                 |  |
| Level                | 1-16   |
| Region               | A scope is specifiable.  |
| Layer                |  |
| Opacity              | Available  |
| Visibility           | Available—dynamics allocation available (initial value: show)                        |
| Capacity information |  |
| Bing®                | Bing Maps Key  |
| Esri®                | Username, Password, Root URL   |
| OGC WMS              | Provider Address, Additional Parameters  |

| Smart pin  |   |
|------------|---|
| Allocation | GraphWorX64 object, latitude/longitude  |
| Setting    | Dialog  |
|            | Size [Add/delete row/column]  |
|            | Color [In smart icon]   |
|            | Data collection [OPC, OPC UA, Global Aliasing, Language Aliasing, simulation, expression, Local Aliasing] |
|            | Tool tip [Settable, data accepted]  |
| Pushpin    |   |
| Allocation | GraphWorX64 object, latitude/longitude  |
| Setting    | Fill, zoom, shadow  |

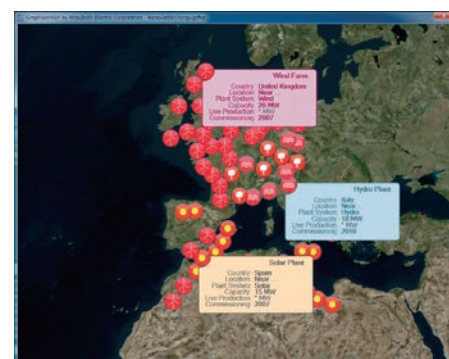



Microsoft Azure®, the Cloud service by Microsoft®, is supported. You can store data and server applications on the Cloud to construct a flexible system.

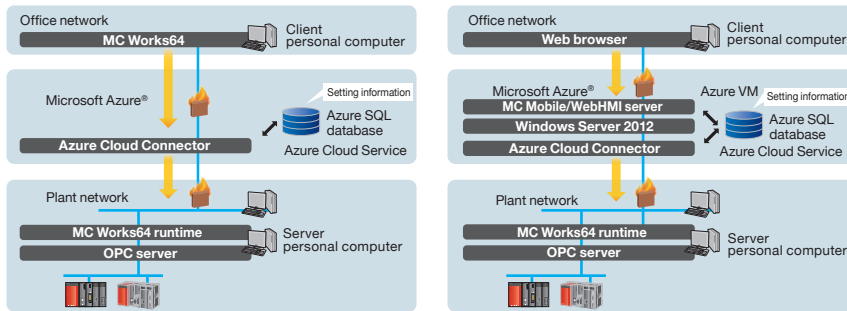

1. How to use Microsoft Azure® as a communication route  
**Merit:** You can monitor a subject easily and safely.

2. How to have a server application on Microsoft Azure®  
**Merit:** You can save the labor for the management of a server personal computer.

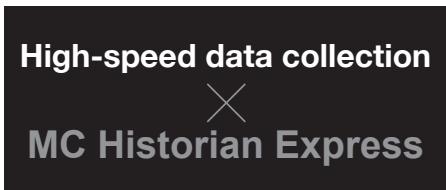

MC Historian Express is a simplified version of the optional data collection tool MC Historian (see P24). Using its own data storage format means that a commercial database engine is not required and it provides fast data collection. This Express version is available as part of the standard MC Works64 license.

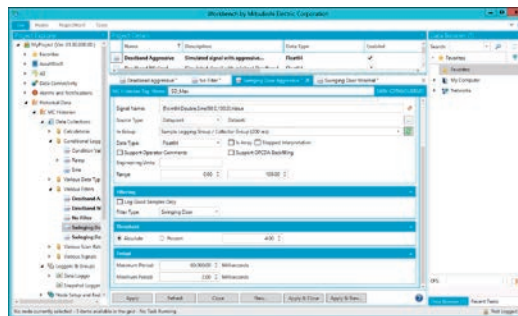
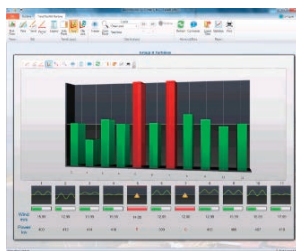

Configuration screen

- \* : MC Historian Express will use MC Works64 license tags for logging.
- \* : The maximum number of possible logging tags are 5000.

**Message notification**  
 ✕  
**AlertWorX & MC Alarm64 MMX** (optional)

These applications link alarms with email and SMS notifications. Users can receive messages containing information such as: the date and time that the alarm occurred, the type of alarm and the alarm name. Using AlertWorX, a standard feature of MC Works64, it is possible to notify a single user via a simple configuration. Additionally, the optional package MC Alarm64 MMX allows for much more advanced settings. For example, depending on the type of alarm that occurs a different group of users can be notified; such as the operators or the engineers. Within that, the operators that are notified can be changed depending on the current work shift. It is possible to automatically change the notifications destination at the time the alarm occurs.

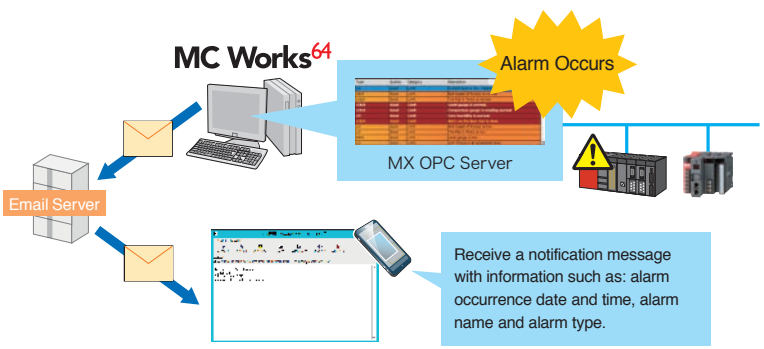

**Personalized monitoring displays**  
 ✕  
**KPIWorX**

During runtime mode, it is possible to create a personalized monitoring display. There are a variety of widgets available (device symbols, alarms, trends etc.) that can be arranged on the screen as desired in order to display the necessary data. After creating these displays it is possible to save them and reload them at a later time; either for viewing or further customization.

This block contains three screenshots illustrating the KPIWorX interface. The first screenshot shows a 'Symbol library' window with a circular gauge widget on the main display. Two callouts are present: '1. Select an object from the symbol library and place it into the display.' and '2. Assign a tag to the symbol'. The second screenshot shows a 'Symbol library' window with various control symbols like gauges and indicators. A callout states: 'It is possible to customize various settings, such as the symbol's colour.' The third screenshot shows a tablet displaying a monitoring display with multiple gauges and indicators. A callout below it says: 'Also supported in MC Mobile'.

# Options

High-speed,  
reliable data collection  
×  
MC Historian

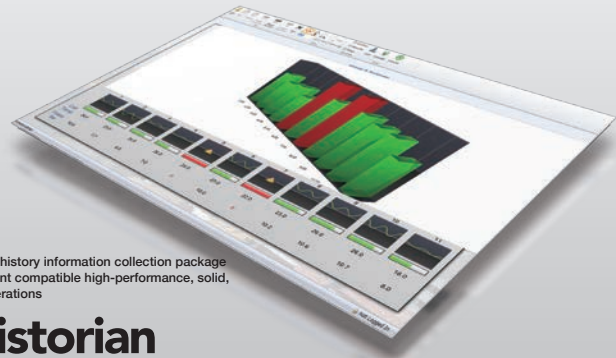

Real-time production history information collection package with 64-bit environment compatible high-performance, solid, scalable and safe operations

## MC Historian

A high performance and high reliability data logger that can collect 100,000 points per second\* (by comparison, the collection performance of the TrendWorX64 is 20,000 points per second\*). It is also possible to log the result of a calculation based upon a user-defined formula. Long term logging is possible thanks to a high-compression logging feature. High reliability can be ensured through redundancy and distributed processing. Depending on the target application there are 3 available versions; standard (SD), enterprise (ET) and redundant (RT).

A simplified version of MC Historian is freely available in both MC Works64 and MC Mobile packages called MC Historian Express.

\*: Depends on the system configuration.

| Features/Specifications   | MC Historian SD/ET/R (Optional packages) | MC Historian Express (MC Works64 Standard Package) |
|---|--|--|
| High-speed Logging  | ●  | ●  |
| Performance Calculations  | ●  | —  |
| Powerful Compression Filtering  | ●  | —  |
| Save data into an HDD file (TrendWorX data is saved into an SQL database) | ●  | ●  |
| Redundant   | ●*                                       | —  |
| Distributed Architecture  | ●*                                       | —  |
| Maximum Tag Count   | No Limit                                 | 5000   |
| Tag Counting Method   | Counted as MC Historian Tags             | Counted as MC Works64 Tags                         |

\*: Supported in MC Historian ET and R only

Energy monitoring  
×  
AX Energy



Energy consumption rate visualization and analysis tool for system and device levels

## AX Energy

It is possible to visualize and analyze CO<sub>2</sub> emissions and the consumption of energy, including electricity and gas, based on plant, facility and device leading to energy savings and cutting costs. You can express daily and monthly energy consumption in the form of a graph, and you can easily switch their views. You can also use Microsoft® Excel® to create a form in the format of your choice.



## Preventive maintenance X AX Facility



Device fault detection and analysis tool

## AX Facility

It is possible to use prior knowledge on equipment faults to create a resource that improves recovery times. It is possible to analyze the causes of facility troubles together with their frequency to know their trends, providing aid for preventive maintenance. You can use Microsoft® Excel® to create a form in the format of your choice from the result of analysis.

## Quality control X AX Quality



A complete quality analysis solution providing SQC/ SPC data analysis

## AX Quality

AX Quality creates management charts for the analysis of quality control and process capacity, reducing the labor of onsite operators and managers. AX Quality provides SQC/SPC data analysis, SQC charts, reports, and SPC rule-based alarms.

## Web monitoring X AX Portal



Web analysis screen programming support tool

## AX Portal

You can use a web browser to monitor screens created in MC Works64, AX Energy, AX Facility and AX Quality.

You can divide a screen for the integral view of these functions.

Mitsubishi Electric FA integrated solution



e-F@ctory is the Mitsubishi Electric solution for improving the performance of any manufacturing enterprise by enhancing productivity, and reducing the maintenance and operations costs together with seamless information flow throughout the plant.

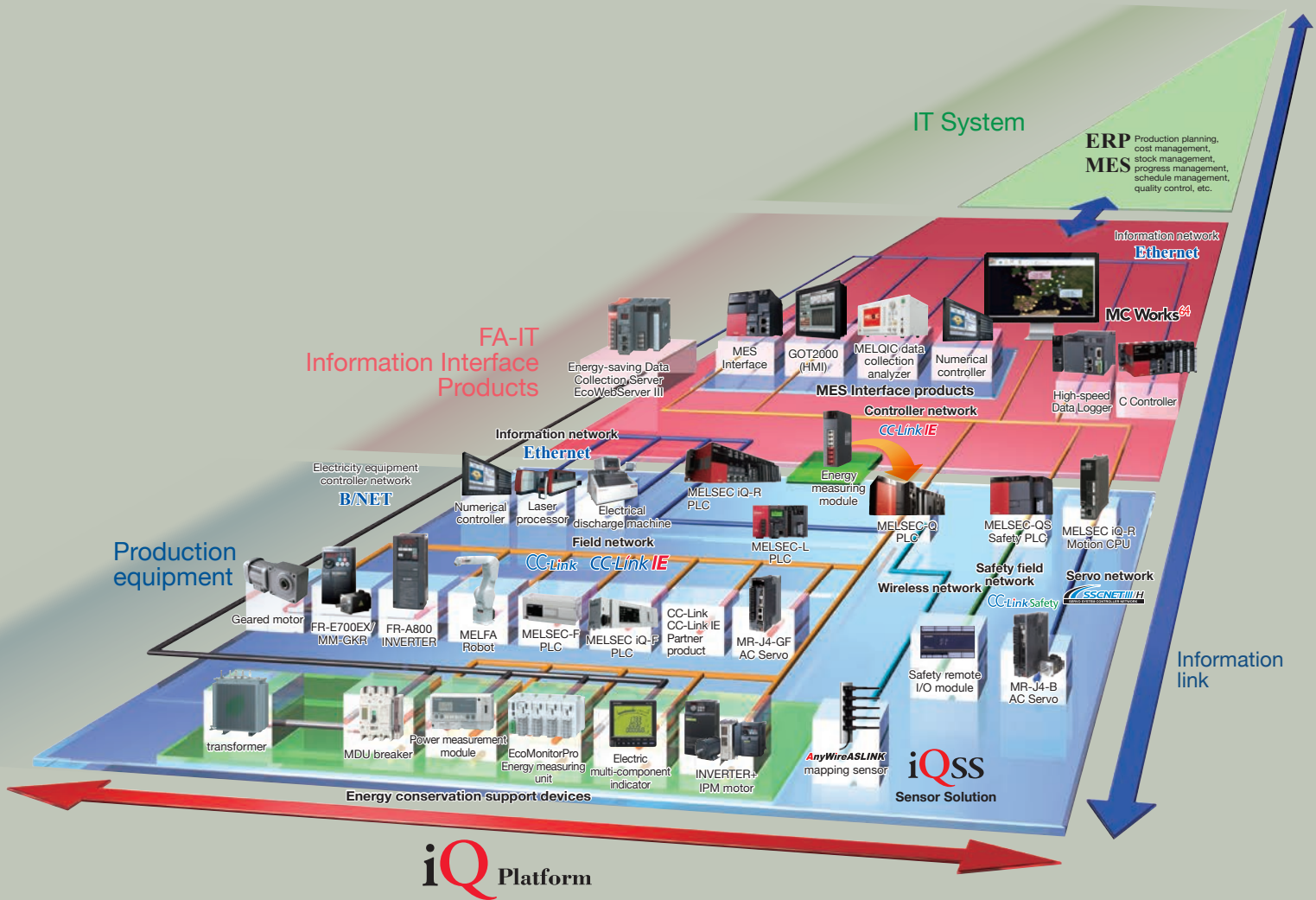

# Automotive Industry



MC Works64 can be applied at every process in an automotive plant to create a complete monitoring control system. For production control, the yield and facility information based on each process is stored on a database server in MC Works64 via the integrated programmable controller and the MES interface.

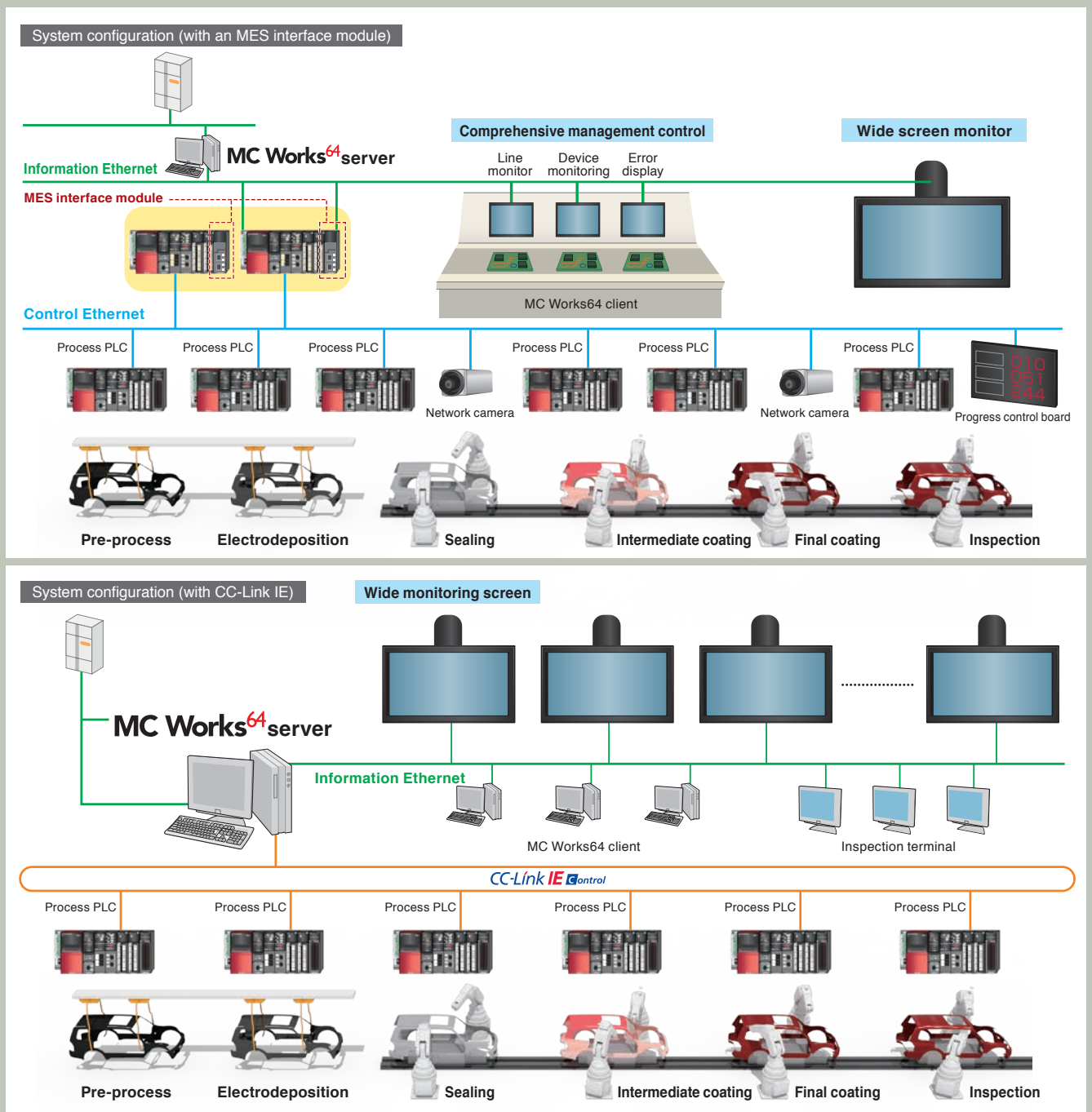

# Electrical / Electronics Industry

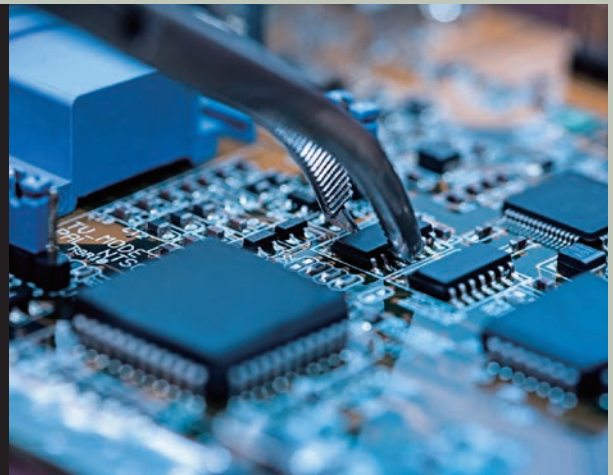

MC Works64 can be applied for the monitoring control of an assembly plant of electrical machinery and electronics. The programmable controller of each process uses the 2D codes inscribed on work to collect the product ID. Each process' yield is stored in the MC Works64 database using the MES interface which manages each unit of work. Based upon recipe data, production information and quality information in the database, it is possible to create various forms (such as assembly yields and quality records) to secure traceability.

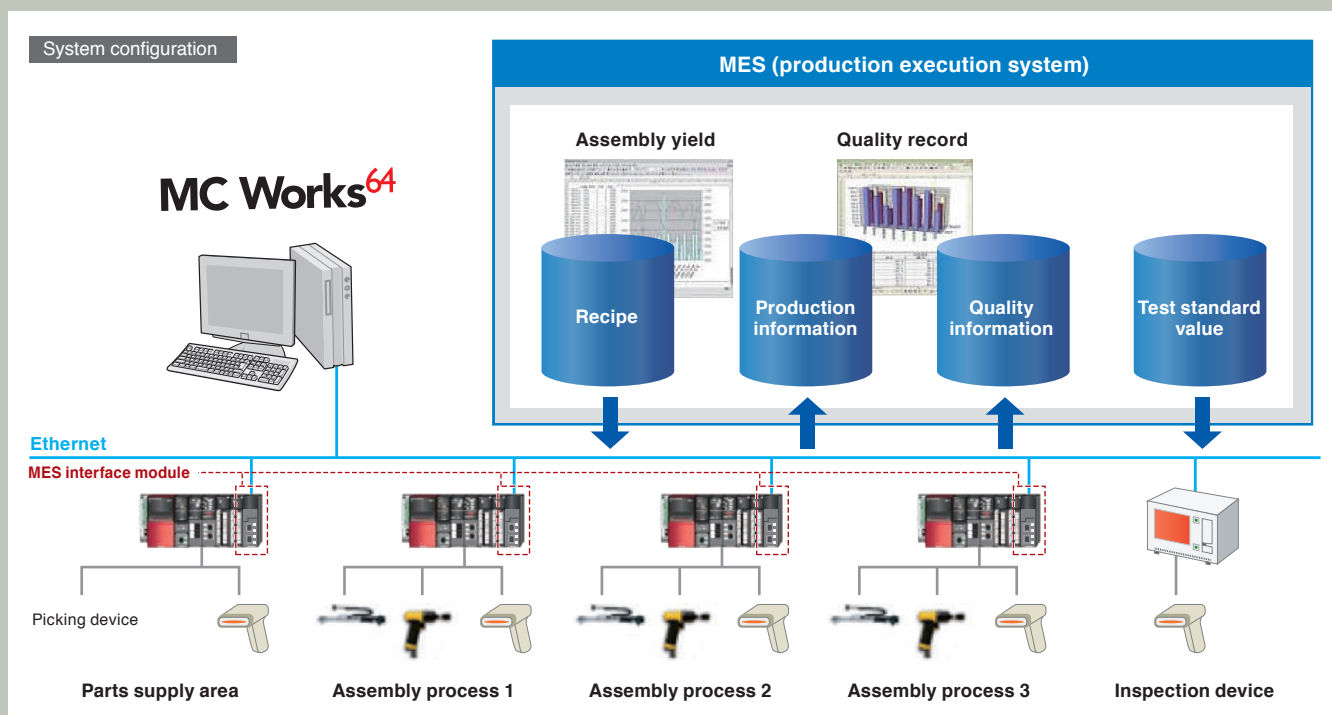
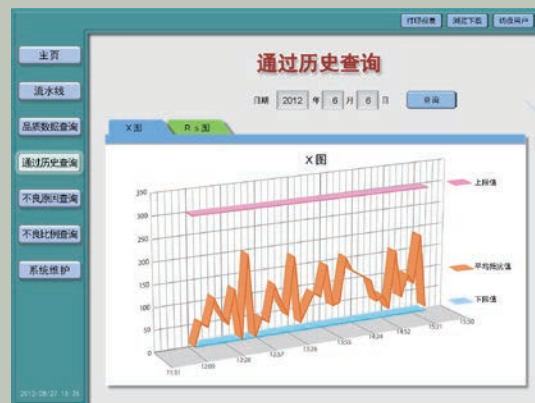

# Air-conditioning / Facility



We recommend MC Works64 for the monitoring control of building and plant air-conditioning and facilities. This provides a variety of solutions: monitoring control linked to an air-conditioning controller, the visualization of energy with EcoWebServer III and energy measurement equipment. It also provides an energy-saving solution linked to a high-efficiency inverter and a building's wire-saving network.

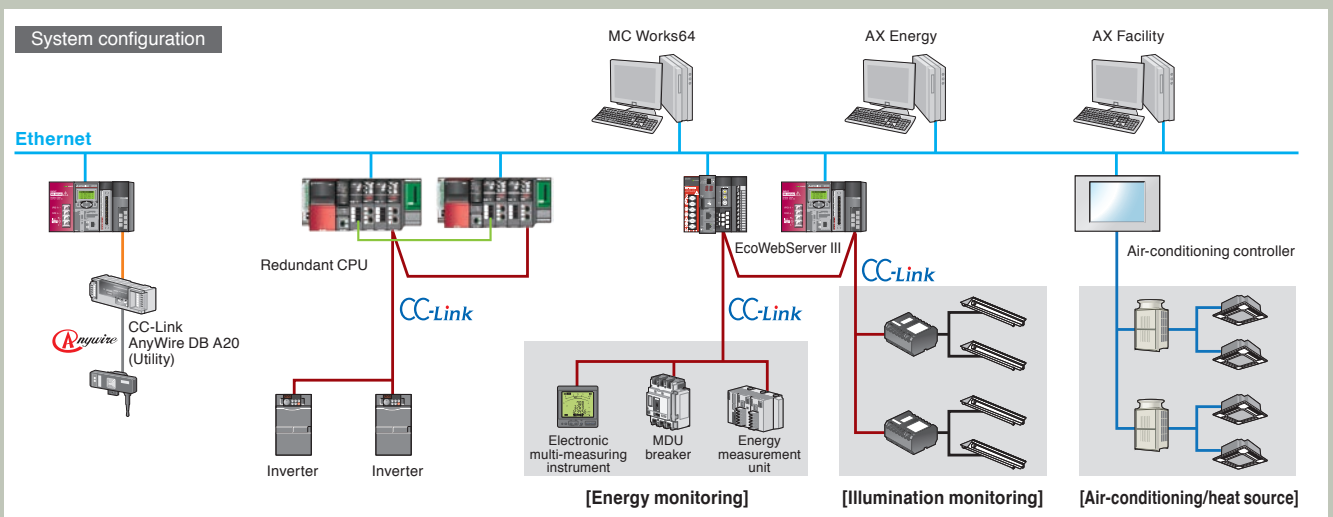
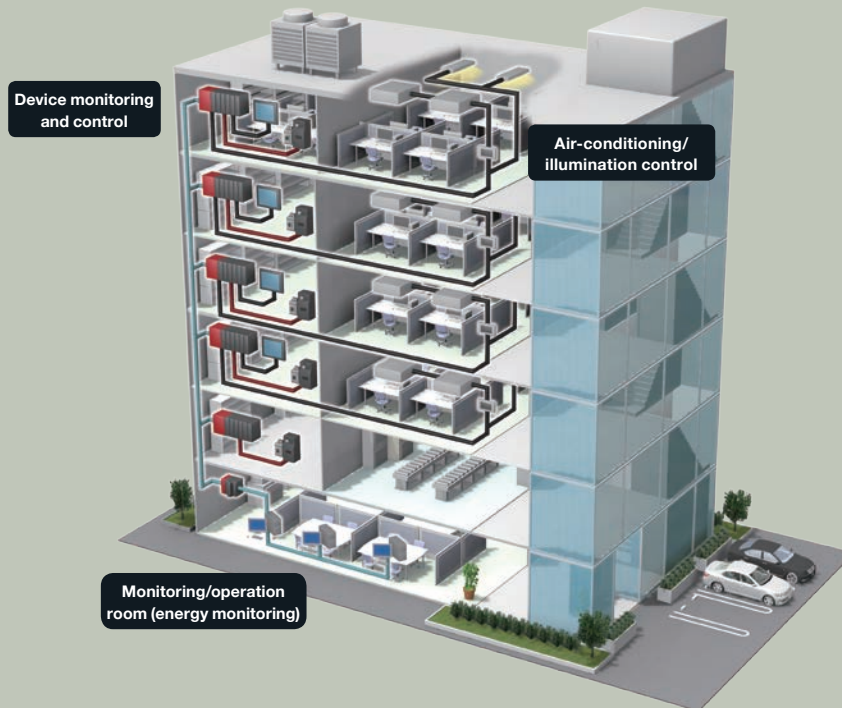

# Food and Beverage



We propose MC Works64 for the monitoring control of production processes of a food/beverage plant ranging from the upstream processes (the PA control of compound processes etc.) to the downstream processes (the factory automation control of packing, transport, etc.) as well as for the monitoring control of utilities.

The monitoring control by MC Works64 involves server redundant and server and client configuration to construct a system where the load distribution is enabled in a highly reliable network. In addition, you can use a CC-Link IE Control network to connect a programmable controller for integration and, furthermore, you can use a MELSECNET/H remote I/O network to distribute and connect I/Os, thus realizing the configuration of a hierarchical network system.

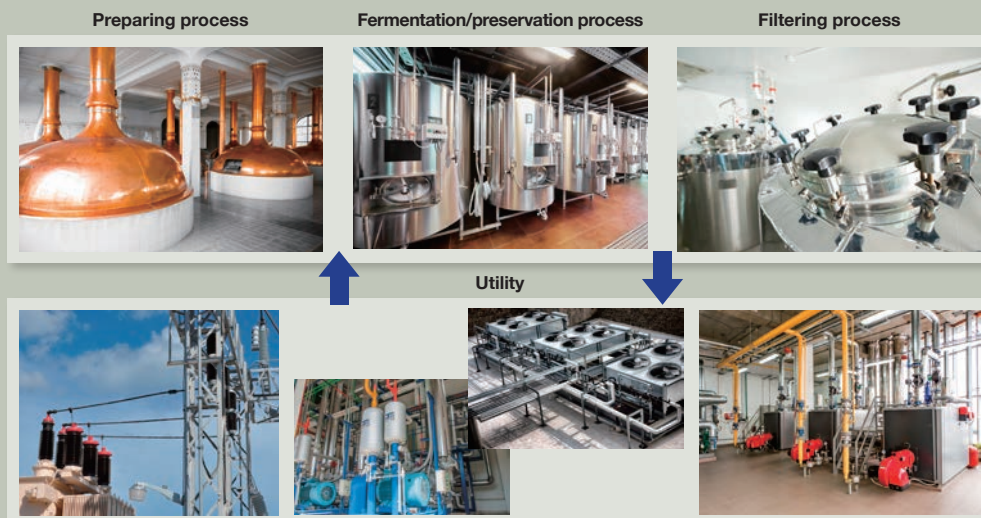

Power reception, boiler, freezing machine, compressor, water reception, drainage, etc.

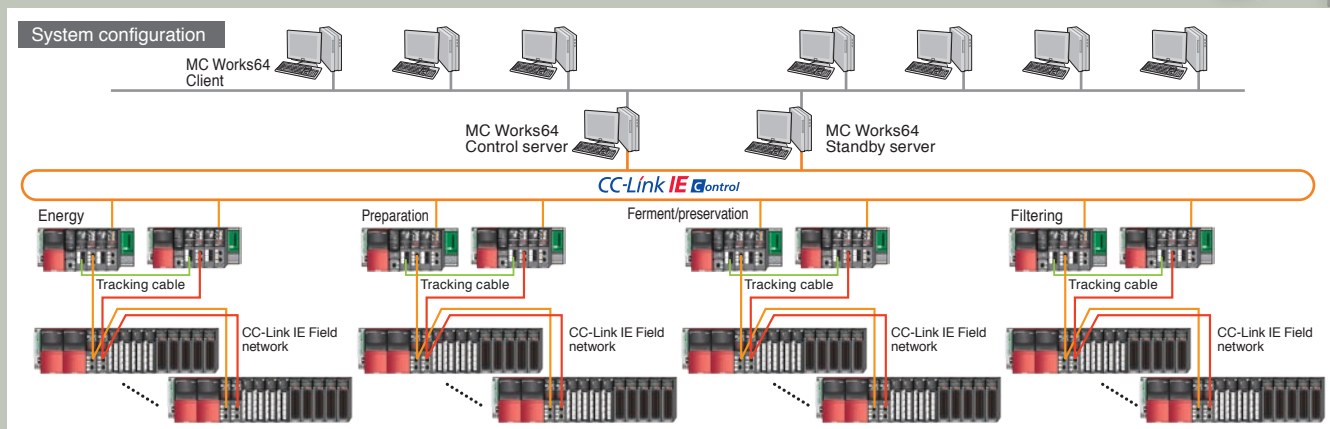

# Steel Industry



We propose MC Works64 for the monitoring control of each process and utility at a steel plant. Redundant CPUs enables you to construct a highly reliable system. A CC-Link IE Control network connects a programmable controller for integration. Moreover, you can use a MELSECNET/H remote I/O network to connect distributed I/Os for the construction of a hierarchical network system.

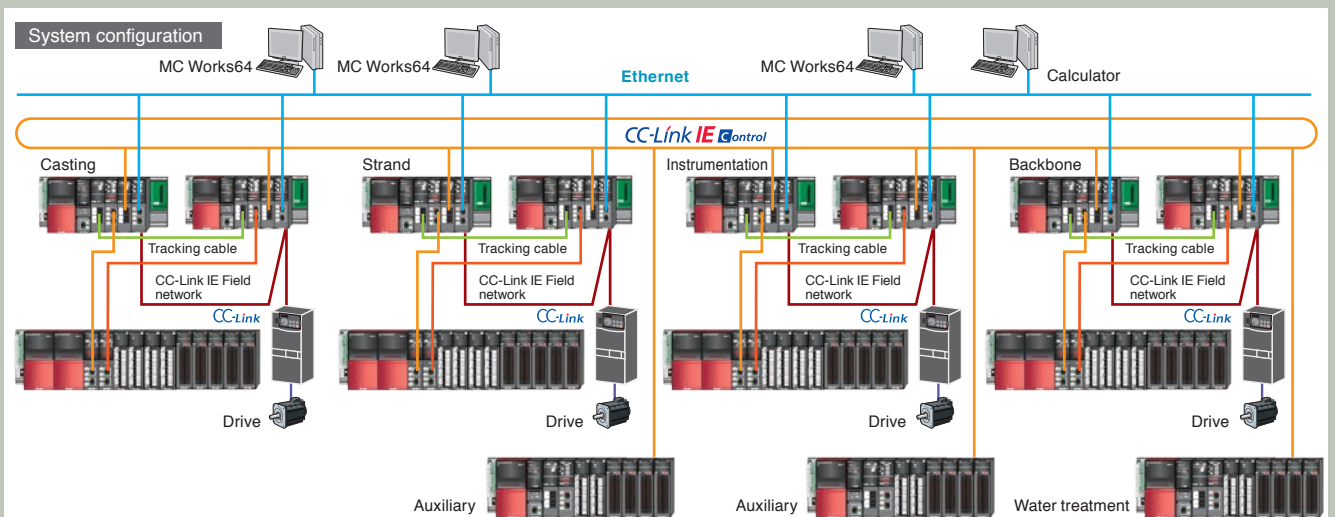
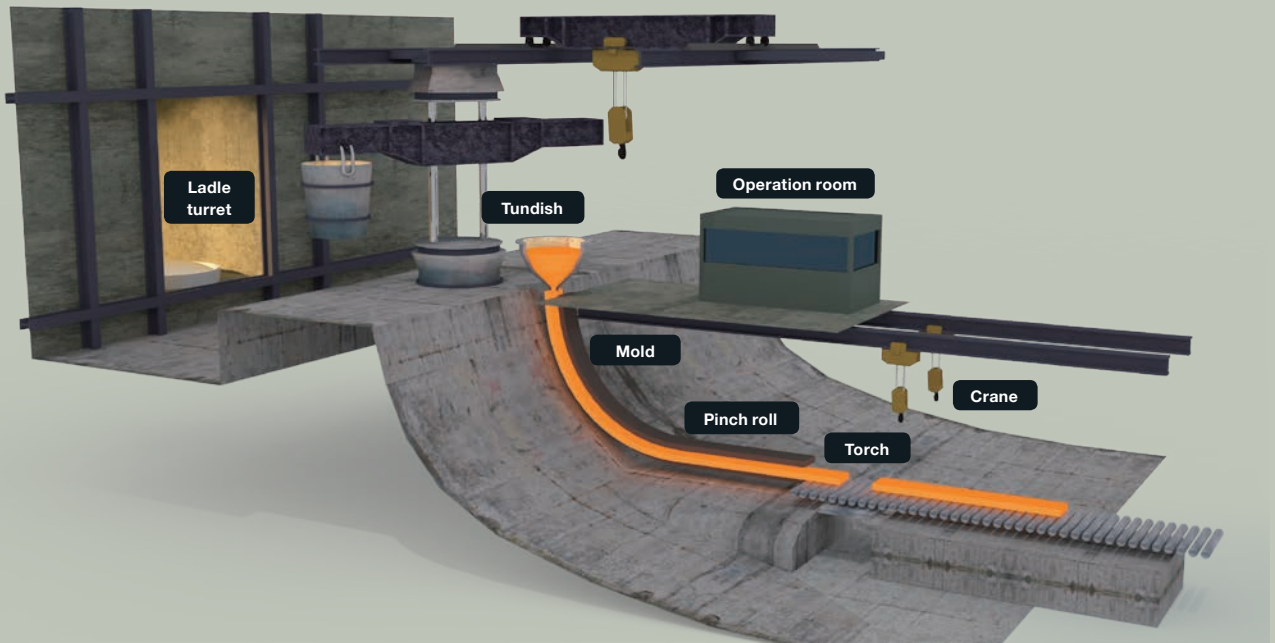

# Chemical Industry



The use of MC Works64 can provide a total solution. This includes process and utility monitoring control and production control for a plant producing industrial chemicals, high-functional materials and medical products.

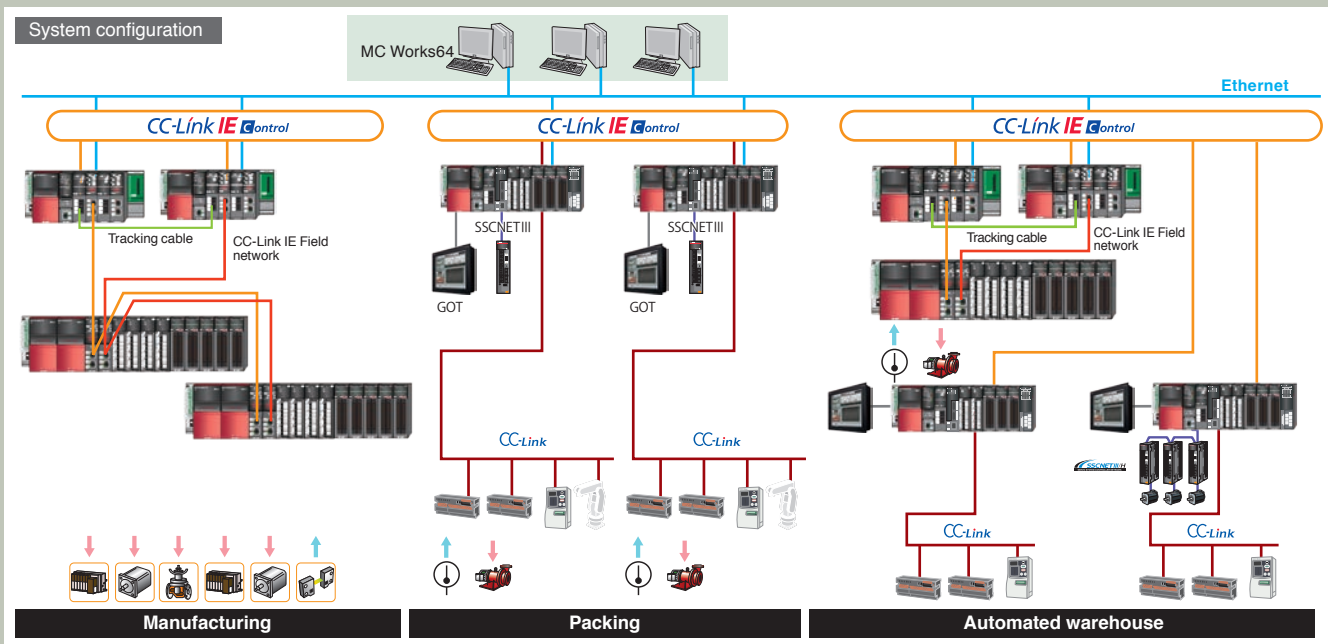
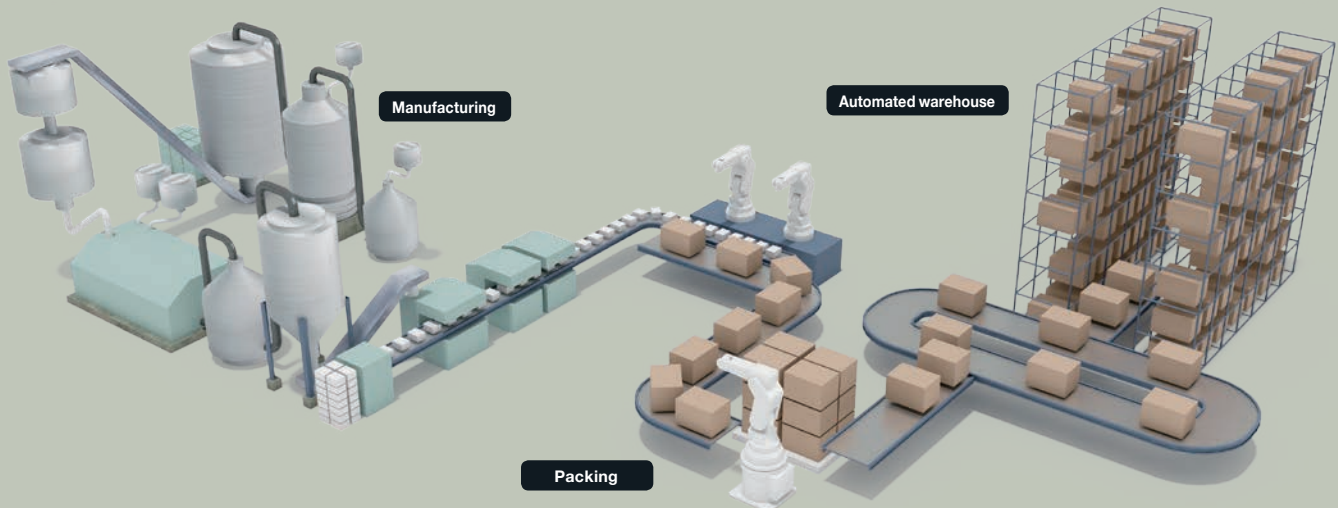



# Incineration Power Plant



MC Works64 can be applied to an incineration power plant for monitoring and controlling: the incinerator, the boiler, utilities, gas treatment, and power generation processes.

Redundant CPUs, a CC-Link IE Control network and redundant MC Works64 servers can construct a high reliability system. Mitsubishi Electric proposes a total solution ranging from the process monitoring control with redundant CPUs to the visualization of generated energy with MC Works64.

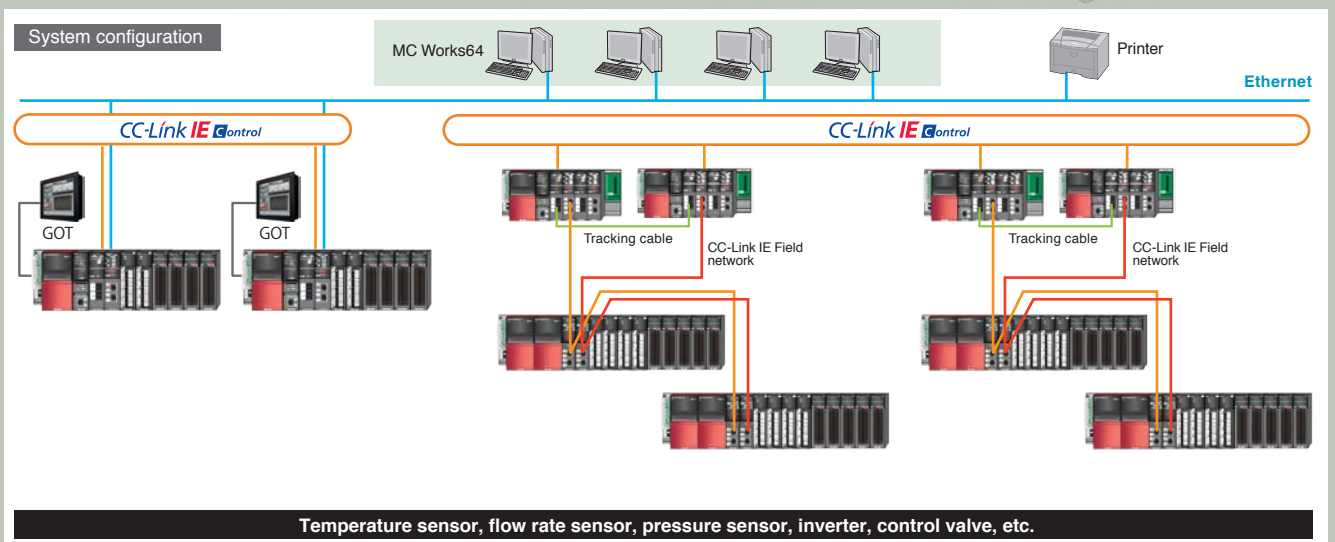
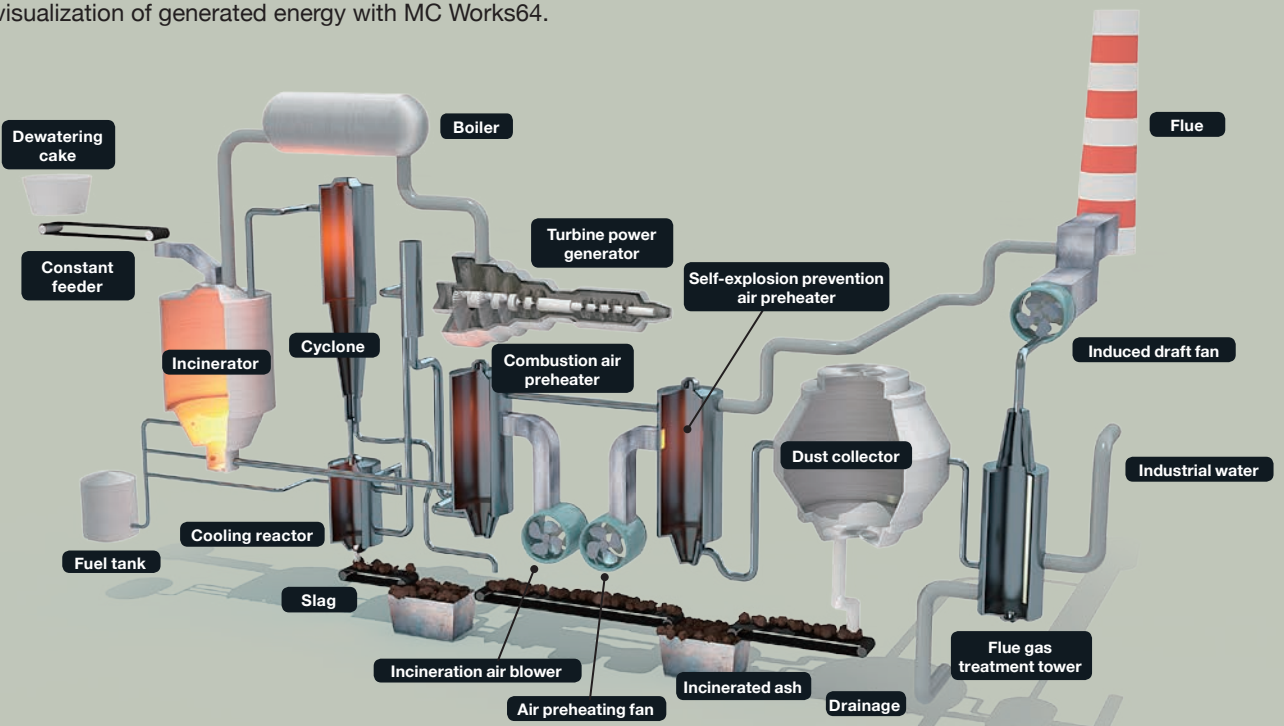

# Product List

## Basic products

| Product name             | Model              | Tag  | Description   |                    |
|--------------------------|--------------------|--|---|--------------------|
|                          |                    |  | Basic package   | Additional package |
| MC Works64 DV            | SW3DND-MCWDV-ET    | 75, 150, 500, 1500, 5k, 15k, 50k, 100k, 250k           | Graphic/alarm/trend (development version)   |                    |
| MC Works64 RT            | SW3DND-MCWRT-ET    | 75, 150, 500, 1500, 5k, 15k, 50k, 100k, 250k           | Graphic/alarm/trend (runtime/dynamic tag count version (see p. 35)).  |                    |
| MC Works64 LT            | SW3DND-MCWL-ET     | 75, 150, 500, 1500, 5k                                 | Graphic/alarm/trend (runtime/static tag count version (see p. 35)).   |                    |
| MC Graph64 DV            | SW3DND-MCGDV-ET    | 75, 150, 500, 1500, 5k, 15k, 50k, 100k, 250k           | Graphic (development version)   |                    |
| MC Graph64 RT            | SW3DND-MCGRT-ET    | 75, 150, 500, 1500, 5k, 15k, 50k, 100k, 250k           | Graphic (runtime version)   |                    |
| MC Alarm64 DV            | SW3DND-MCADV-ET    | 75, 150, 500, 1500, 5k, 15k, 50k, 100k, 250k           | Alarm (development version)   |                    |
| MC Alarm64 RT            | SW3DND-MCART-ET    | 75, 150, 500, 1500, 5k, 15k, 50k, 100k, 250k           | Alarm (runtime version)   |                    |
| MC Historian SD          | SW3DND-MCHSD-ET    | 75, 150, 500, 1500, 5k, 15k, 50k, 100k, 250k, 500k, 1M | High-speed data collection  |                    |
| MC Historian ET          | SW3DND-MCHET-ET    | 75, 150, 500, 1500, 5k, 15k, 50k, 100k, 250k, 500k, 1M | High-speed data collection (redundant collection function version)  |                    |
| MC Historian R           | SW3DND-MCHR-ET     | 75, 150, 500, 1500, 5k, 15k, 50k, 100k, 250k, 500k, 1M | Redundant configuration MC Historian (2 licenses of MC Historian ET)  |                    |
| MC Historian C           | SW3DND-MCHC-E      | —  | MC Historian R remote collector license<br>(to add a distributed collection server to MC Historian ET)<br>(The remote collector is compatible only with the expansion version.) |                    |
| MC Historian CR          | SW3DND-MCHCR-E     | —  | MC Historian R remote collector license<br>(to add a distributed collection server to redundant MC Historian ET)  |                    |
| MC Works64 CL RT         | SW3DND-MCWCLRT-EK  | —  | Additional 1, 5, 25, 100, 500 client licenses   |                    |
| MC Works64 CL DV         | SW3DND-MCWCLDV-EK  | —  | Additional 1, 5, 25 development version client licenses   |                    |
| MC Works64 CL R          | SW3DND-MCWCLR-EK   | —  | 1, 5, 25 Additional client licenses for a redundant configuration   |                    |
| MC Works64 CL LT         | SW3DND-MCWCLLT-EK  | —  | 1, 5, 25, 100, 500 Additional Web browser client licenses   |                    |
| MC Works64 RO RT         | SW3DND-MCWRORT-EK  | —  | 1, 5, 25, 100, 500 Additional read-only client licenses   |                    |
| MC Works64 RO R          | SW3DND-MCWROREK-EK | —  | 1, 5, 25 Additional read-only client licenses for a redundant configuration   |                    |
| MC Works64 RO LT         | SW3DND-MCWROLT-EK  | —  | 1, 5, 25, 100, 500 Additional read-only client licenses for a Web browser   |                    |
| MC Mobile SV             | SW3DND-MCMSV-E     | —  | Remote monitoring/operation from a mobile/tablet terminal<br>+2MC Mobile CL (including 2 client licenses)<br>(MC Works64 license needs to be purchased separately.)             |                    |
| MC Mobile LT             | SW3DND-MCMLT-E     | —  | Remote monitoring/operation from a mobile/tablet terminal<br>+MC Works64 DV (including 75 tags)<br>+MC Mobile CL (including 2 client licenses)                                  |                    |
| MC Mobile SD             | SW3DND-MCMSD-E     | —  | Remote monitoring/operation from mobile/tablet terminal<br>+MC Works64 DV (including 5k tags)<br>+MC Mobile CL (including 25 client licenses)                                   |                    |
| MC Mobile ET             | SW3DND-MCMEET-E    | —  | Remote monitoring/operation from mobile/tablet terminal<br>+MC Works64 DV (including 100k tags)<br>+MC Mobile CL (including 500 client licenses)                                |                    |
| MC Mobile CL             | SW3DND-MCMCL-EK    | —  | Additional 1, 5, 25, 100, 500 client licenses   |                    |
| MC Mobile RO             | SW3DND-MCMRO-EK    | —  | Additional read-only client license (MC Mobile license needs to be purchased separately.)   |                    |
| MC Works USB Key         | NZ2HK-IPS          | —  | USB license key   |                    |
| MC Works64 Language Pack | SW3DND-MCWLG-M     | —  | MC Works64 Japanese-language and Chinese-language version package products  |                    |
| MC Alarm64 MMX LT        | SW3DND-MCAMMLT-E   | —  | E-Mail Notifications for Alarms   |                    |
| BridgeWorX Lite          | SW2DND-BWLT-E      | —  | 5 transactions  |                    |
| ReportWorX Lite          | SW2DND-RWLT-E      | —  | 5 reports   |                    |

\*: MX OPC Server does not support Japanese.  
Purchase DeviceXplorer OPC Server for Japanese-language support.

## Function list

| Product name    | Configuration                          |  |  |  |   |   |   |  |                                    |                           |  |
|-----------------|--|--|--|--|---|---|---|--|------------------------------------|---------------------------|--|
|                 | MC AppBuilder<br>[Design support tool] | GraphWorX64<br>View Client<br>[Graphics (runtime)] | AlarmWorX64<br>View Client<br>[Alarm monitoring] | TrendWorX64<br>View Client<br>[Trend monitoring] | GraphWorX64<br>Development<br>Option<br>[Graphics generation] | AlarmWorX64<br>Development<br>Option<br>[Alarm collection/<br>logger setting] | TrendWorX64<br>Development<br>Option<br>[Trend monitoring/<br>logger setting] | ReportWorX<br>Express<br>[Simplified-version<br>form tool] | BACnet™<br>[BACnet™<br>connection] | SNMP<br>[SNMP connection] | GridWorX64<br>[Table-format<br>data display] |
| MC Works64 DV   | ●                                      | ●  | ●  | ●  | ●   | ●   | ●   | ●  | ●                                  | ●                         | ●  |
| MC Works64 RT   | ●                                      | ●  | ●  | ●  | —   | —   | —   | ●  | ●                                  | ●                         | ●  |
| MC Works64 LT   | ●                                      | ●  | ●  | ●  | —   | —   | —   | ●  | —                                  | —                         | —  |
| MC Graph64 DV   | ●                                      | ●  | —  | —  | ●   | —   | —   | ●  | —                                  | —                         | ●  |
| MC Graph64 RT   | ●                                      | ●  | —  | —  | —   | —   | —   | ●  | —                                  | —                         | ●  |
| MC Alarm64 DV   | ●                                      | —  | ●  | —  | —   | ●   | —   | ●  | —                                  | —                         | —  |
| MC Alarm64 RT   | ●                                      | —  | ●  | —  | —   | —   | —   | ●  | —                                  | —                         | —  |
| MC Historian SD | —                                      | —  | —  | ●  | —   | —   | ●   | ●  | ●                                  | ●                         | —  |
| MC Historian ET | —                                      | —  | —  | ●  | —   | —   | ●   | ●  | ●                                  | ●                         | —  |

\*: ReportWorX Express is an on-demand form tool that runs with 32/64 bit Microsoft® Excel®.  
Purchase ReportWorX Lite for the outputs in HTML, PDF, or other formats and for automatic daily/monthly form outputs.

| Product name    | Configuration                  |   |  |  |                               |   |  |   |  |
|-----------------|--------------------------------|---|--|--|-------------------------------|---|--|---|--|
|                 | ScheduleWorX64<br>[Scheduling] | ScriptWorX64<br>[Script generation/<br>runtime] | UDM Tag<br>Restricted<br>[Tag restriction] | MC Historian Server<br>[High-speed data<br>collection] | MX OPC Server<br>[OPC server] | EarthWorX64<br>[Wide area monitoring<br>screen] | Workbench64<br>[Development tool<br>environment] | Modbus® OPC<br>Server<br>[Modbus® OPC server] | WebHMI64 Server<br>[Web publication<br>function] |
| MC Works64 DV   | ●                              | ●   | —  | —  | ●                             | ●   | ●  | ●   | ●  |
| MC Works64 RT   | ●                              | ●   | —  | —  | ●                             | —   | ●  | ●   | ●  |
| MC Works64 LT   | —                              | ●   | ●  | —  | ●                             | —   | ●  | ●   | ●  |
| MC Graph64 DV   | —                              | ●   | —  | —  | ●                             | ●   | ●  | ●   | ●  |
| MC Graph64 RT   | —                              | ●   | —  | —  | ●                             | —   | ●  | ●   | ●  |
| MC Alarm64 DV   | —                              | ●   | —  | —  | ●                             | —   | ●  | ●   | ●  |
| MC Alarm64 RT   | —                              | ●   | —  | —  | ●                             | —   | ●  | ●   | ●  |
| MC Historian SD | —                              | ●   | —  | —  | ●                             | —   | ●  | ●   | ●  |
| MC Historian ET | —                              | ●   | —  | ●<br>[Redundant collection<br>function version]        | ●                             | —   | ●  | ●   | ●  |

| Product name    | Configuration                                    |                                     |   |  |  |
|-----------------|--|-------------------------------------|---|--|--|
|                 | WebHMI64 CAL<br>[WebHMI64 client in client type] | FrameWorX<br>[Application platform] | Unified Data Manager<br>[Data source control] | OPC-UA Data Bridging<br>[OPC UA data conversion] | Distribute Collector<br>[Distribution type collection server<br>of MC Historian] |
| MC Works64 DV   | 1Client (MC Works64 CL DV)                       | ●                                   | ●   | ●  | —  |
| MC Works64 RT   | 1Client (MC Works64 CL RT)                       | ●                                   | ●   | ●  | —  |
| MC Works64 LT   | 1Client (MC Works64 CL LT)                       | ●                                   | ●   | ●  | —  |
| MC Graph64 DV   | 1Client (MC Works64 CL DV)                       | ●                                   | ●   | ●  | —  |
| MC Graph64 RT   | 1Client (MC Works64 CL RT)                       | ●                                   | ●   | ●  | —  |
| MC Alarm64 DV   | 1Client (MC Works64 CL DV)                       | ●                                   | ●   | ●  | —  |
| MC Alarm64 RT   | 1Client (MC Works64 CL RT)                       | ●                                   | ●   | ●  | —  |
| MC Historian SD | 1Client (MC Works64 CL DV)                       | ●                                   | ●   | ●  | —  |
| MC Historian ET | 1Client (MC Works64 CL DV)                       | ●                                   | ●   | ●  | 2 licenses   |

## ■ Selecting basic products

### Selecting an MC Works64 server (If you not require MC Works64 but want the data collection function, got to 2 and select MC Historian)

**1 Example:** MC Works64 DV OL  
Consider (1) (2) and (3) as shown below.

#### (1) Selecting server functions

1. If you will use graphics, alarms, and trend functions, select MC Works64.  
2. If you will use only graphic functions, select MC Graph64.  
3. If you will use only alarm functions, select MC Alarm64.  
Example. Select MC Works64 when you need graphics, alarms, and trend functions.

#### (2) Selecting server development versions/runtime versions

1. If you will use a development version on a server (the tag count depends on dynamic tags), select DV.  
2. If you will use a runtime version (display function) on a server (the tag count depends on dynamic tags), select RT.  
3. If you will use a runtime version (display function) on a server (the tag count depends on static tags), select LT.  
Example. Select MC Works64 [DV] when you need a development version (the tag count depends on dynamic tags).  
Note: Dynamic (on demand) tags refers to unique tags that are currently in use. If a tag is no longer being used it will be made available for use by another tag.  
Static (configuration) tags refers to the number of unique tags that exist in the project as a whole. With this kind of license, if there are more unique tags than available ones, only the first X tags will be used (X being equal to the amount of available tags).

#### (3) Selecting OPC servers

1. If you will use an MX OPC server, select "-" (an MX OPC server is bundled).  
2. If you will not use a MX OPC server, select OL (MX OPC Server is not bundled).  
Example. Select MC Works64 DV [OL] when you need a DeviceExplorer OPC server.

#### Selecting redundant servers

1. If redundant servers are required, select two licenses or a redundant version of the product.  
2. If redundant servers are not required, only select single license products.  
Example. Select MC Works64 DV OL [two licenses] when you need redundant servers.

### Selecting MC Historian servers (If you do not need data collection or if the collection speed is 50k points per minute or less, use the trend functions of MC Works64. Go to 3.)

**2 Example:** MC Historian ET OL  
Consider (1) and (2) as shown below.

#### (1) Selecting redundant servers

1. If redundant servers are required, select the two-license ET or the one-license R.  
2. If redundant servers are not required, only select single license SD.  
Example. Select MC Historian [ET] [two licenses] or MC Historian [R] [one license] when you require redundant servers.

#### (2) Selecting OPC servers

1. If you will use an MX OPC server, select "-" (an MX OPC server is bundled).  
2. If you will not use a MX OPC server, select OL (MX OPC Server is not bundled).  
Example. Select MC Historian ET [OL] [two licenses] or MC Historian R [OL] when you need a DeviceExplorer OPC server.

### Selecting MC Works64/MC Historian client (If you do not need a client, go to 4.)

**3 Example:** MC Works64 CL RT  
Consider (1) and (2) as shown here.

#### (1) Selecting writeable and read-only clients

1. If a client is required for development or writing values from a display is necessary, select CL.  
2. If you do not need to write values from a display (read-only), select RO

#### (2) Selecting development and runtime versions

1. If a development version is necessary (even if the server is redundant), select DV (Even if the server itself is using the development version, it is possible to combine it with runtime clients)  
2. If a runtime version is necessary (not limited to only Web browsers, server is not redundant), select RT  
3. If a runtime version is necessary (limited to only Web browsers, server is not redundant), select LT  
4. If a runtime version is necessary (server is redundant), select R  
Example. Example. Select MC Works64 CL [DV] when you need a development version.

### Selecting MC Historian remote collector (If you do not need a remote collector, go to 5.)

**4 Example:** MC Historian C  
Consider (1) as shown here.

A remote collector refers to a function that uses a personal computer other than the server to collect data and sends data to the server.

#### (1) Selecting remote collectors

1. If your MC Historian server does not have a redundant configuration, select C.  
2. If your MC Historian server has a redundant configuration, select CR.  
Example. Select MC Historian [C] when your MC Historian server does not have a redundant configuration.

### Selecting MC Mobile (If you do not need mobile device monitoring, go to 7.)

**5 Example:** MC Mobile ET OL  
Consider (1) and (2) as shown below.

#### (1) Selecting MC Mobile depending on whether you have an MC Works64 license

1. If you have MC Works64 DV license and if you need MC Mobile CL (2 licenses), select SV.  
2. If you want to select MC Works64 DV (75 tags) and MC Mobile CL (2 licenses) as a set, select LT.  
3. If you want to select MC Works64 DV (5k tags) and MC Mobile CL (25 licenses) as a set, select SD.  
4. If you want to select MC Works64 DV (100k tags) and MC Mobile CL (500 licenses) as a set, select ET.  
Example. Select MC Mobile [LT] when you purchase MC Works64 DV (75 tags) and MC Mobile CL (2 licenses) as a set.

#### (2) Selecting OPC servers

1. If you will use an MX OPC server, select "-" (an MX OPC server is bundled).  
2. If you will not use a MX OPC server, select OL (MX OPC Server is not bundled).  
Example. Select MC Mobile LT [OL] when you need a DeviceExplorer OPC server.

### Additional purchase of MC Mobile licenses (If you do not need these licenses, go to 7.)

**6 Example:** MC Mobile CL  
Consider (1) as shown here.

#### (1) Purchasing additional licenses depending on functions

1. If you purchase and specify additional MC Mobile licenses for operation and display functions (1, 5, 25, 100, or 500 licenses), select CL.  
2. If you purchase and specify additional MC Mobile licenses for a display function only (1 license), select RO.  
Example. Select MC Mobile [CL] when you purchase additional MC Mobile licenses for operation and display functions (1, 5, 25, 100, or 500 licenses).

### 7 Selecting an MC Works64 license authentication type (Select one of the two.)

1. If you will use different personal computers for development and runtime (display function) and you want to use one license, select MC Works USB Key (a USB key is used for H/W license authentication).  
2. If you will use the same personal computer for development and runtime (display function), use the Internet for the S/W license authentication.

### 8 Addition Japanese-language and Chinese-language package products (If you do not need a Japanese-language or Chinese-language package, go to 9.)

1. If you need a Japanese-language or Chinese-language package, select MC Works64 Language Pack.  
2. If you do not need a Japanese-language or Chinese-language package, select "-".

### 9 Adding MC Alarm MMX (If you do not need MC Alarm MMX, go to 10.)

1. E-mail notification with advanced features are necessary (utilising a schedule, alarm acknowledgement, etc.), select MC Alarm MMX LT  
2. Only basic e-mail notification features are necessary, select - (Note: E-mail features are included in the standard features of MC Works64)

### 10 Selecting BridgeWorX Lite (If you do not need BridgeWorX Lite [data conversion function] go to 11.)

1. If you need BridgeWorX, select BridgeWorX Lite.  
2. If you do not need BridgeWorX, select "-".

### 11 Selecting ReportWorX Lite (If you do not need any full-fledged form handling processes, end here.)

1. If you need ReportWorX, select ReportWorX Lite.  
2. If you do not need ReportWorX, select "-".

## AnalytiX® products

Basic package Additional package

| Product name    | Model           | Asset                      | Description   |
|-----------------|-----------------|----------------------------|---|
| AX Energy SV    | SW3DND-AXESV-E  | 5                          | Energy monitoring<br>+MC Historian SD (including 5 tags)<br>+ReportWorX (1 report)<br>(MC Works64 license needs to be purchased separately.)  |
| AX Energy *2    | SW3DND-AXE-E    | 5                          | Energy monitoring<br>+MC Works64 DV (including 75 tags)<br>+MC Historian SD (including 5 tags)<br>+1 MC Works64 CL RT<br>+ReportWorX (1 report)   |
| AX Energy AS    | SW3DND-AXEAS-ET | 1, 100, 500                | 10, 1,000, 5,000 tags added to MC Works64<br>1, 100, 500 tags added to +MC Historian<br>(MC Works64 license needs to be purchased separately.)  |
| AX Facility SV  | SW3DND-AXFSV-E  | 5                          | Preventive maintenance<br>+MC Historian SD (including 5 tags)<br>+ReportWorX (1 report)<br>(MC Works64 license needs to be purchased separately.)   |
| AX Facility *2  | SW3DND-AXF-E    | 5                          | Preventive maintenance<br>+MC Works64 DV (including 75 tags)<br>+MC Historian SD (including 5 tags)<br>+1 MC Works64 CL RT<br>+ReportWorX (1 report)  |
| AX Facility AS  | SW3DND-AXFAS-ET | 1, 100, 500, 1500, 5k, 10k | 10, 1,000, 5,000, 15,000, 50,000, 100,000 tags added to MC Works64<br>1, 100, 500, 1,500, 5,000, 10,000 tags added to +MC Historian<br>(MC Works64 license and AX Facility license needs to be purchased separately.) |
| AX Quality SV   | SW3DND-AXQSV-E  | —                          | Quality control (MC Works64 license and MC Historian need to be purchased separately.) <sup>*3</sup>  |
| AX Quality *2   | SW3DND-AXQ-E    | —                          | Quality control<br>+MC Works64 (including 150 tags)<br>+MC Historian (including 150 tags) <sup>*3</sup>   |
| AX Portal SV    | SW3DND-AXPSV-E  | —                          | Web monitoring<br>+MC Works64 CL LT (1 client)<br>(MC Works64 license needs to be purchased separately.)  |
| AX Portal ET *2 | SW3DND-AXPET-E  | —                          | Web monitoring<br>+MC Works64 DV (including 15k tags)<br>+MC Works64 CL RT (25 clients)   |

\*1: AX Energy/AX Facility is licensed depending on the analysis (asset) count not on the tag count.

\*2: MX OPC Server does not support Japanese.

If you want to use Japanese, purchase DeviceXplorer OPC server.

\*3: You can assign AX Quality's functions to all the tags of MC Historian.

## ■ Selecting AnalytiX® products

### Energy monitoring - Selecting AX Energy (If you do not need AX Energy, go to 3.)

**1** Example: **A X E n e r g y S V**  
Consider (1) as shown below.

#### (1) Selecting the availability of MC Works64 licenses and OPC servers

1. If you have MC Works64 licenses and want MC Historian SD (5 tags), ReportWorX (1 report), and AX Energy (5 assets), select SV.
  2. If you select MC Works64 licenses (75 tags), MC Historian SD (5 tags), 1 MC Works64 CL RT, ReportWorX (1 report), and AX Energy (5 assets) and use MX OPC server, select "-".
  3. If you select MC Works64 licenses (75 tags), MC Historian SD (5 tags), 1 MC Works64 CL RT, ReportWorX (1 report), and AX Energy (5 assets) and do not use a MX OPC server, select OL.
- Example. Select AX Energy [OL] when you select MC Works64 licenses and AX Energy and use a DeviceXPlorer OPC server.

### 2 Adding AX Energy tag/asset (If you do not need to add this, go to 3.)

1. If you want to add MC Works64 (10, 1,000 or 5,000 tags), MC Historian (1, 100 or 500 tags), and AX Energy (1, 100 or 500 assets), select AX Energy AS.
2. If you do not want to add tags/assets, select "-".

### Preventive maintenance - Selecting AX Facility (If you do not need AX Facility, go to 5.)

**3** Example: **A X F a c i l i t y S V**  
Consider (1) as shown below.

#### (1) Selecting the availability of MC Works64 licenses and OPC servers

1. If you have MC Works64 licenses and want MC Historian SD (5 tags), ReportWorX (1 report), and AX Facility (5 assets), select SV.
  2. If you will use an MX OPC server, select "-" (an MX OPC server is bundled).
  3. If you will not use a MX OPC server, select OL (MX OPC Server is not bundled).
- Example. Select AX Facility [OL] when you use a DeviceXPlorer OPC server.

### 4 Adding AX Facility tags and assets (If you do not need to add these, go to 5.)

1. If you want to add MC Works64 (10 or 1,000 tags) and AX Facility (1 or 100 assets), select AX Facility AS.
2. If you do not add tags or assets, select "-".

### Quality control - Selecting AX Quality (If you do not need AX Quality, go to 6.)

**5** Example: **A X Q u a l i t y S V**  
Consider (1) as shown below.

#### (1) Selecting the availability of MC Works64/MC Historian licenses and OPC servers

1. If you have MC Works64/MC Historian licenses and want AX Quality, select SV.
  2. If you select MC Works64 licenses (150 tags), MC Historian licenses (150 tags), and AX Quality and use an MX OPC server, select "-".
  3. If you select MC Works64 licenses (150 tags), MC Historian licenses (150 tags), and AX Quality and do not use a MX OPC server, select OL.
- Example. Select AX Quality [OL] when you select MC Works64 licenses, MC Historian licenses and AX Quality and use a DeviceXPlorer OPC server.

### Web monitoring - Selecting AX Portal (If you do not need AX Portal, go to 7.)

**6** Example: **A X P o r t a l E T O L**  
Consider (1) and (2) as shown below.

#### (1) Selecting AX Portal depending on the availability of MC Works64 licenses

1. If you have MC Works64 licenses and want to select MC Works64 CL LT (1 license), select SV.
  2. If you want to select MC Works64 DV licenses (15k tags) and MC Works64 CL LT (25 licenses), select ET.
- Example. Select AX Portal [ET] when you purchase MC Works64 DV licenses and AX Portal as a set.

#### (2) Selecting OPC servers

1. If you will use an MX OPC server, select "-" (an MX OPC server is bundled).
  2. If you will not use a MX OPC server, select OL (MX OPC Server is not bundled).
- Example. Select AX Portal ET [OL] when you select MC Works64 DV licenses and AX Portal and use a DeviceXPlorer OPC server.

### 7 Additional client license (If you do not need to add these, end here.)

1. If an additional client license is needed for AX Energy, AX Facility, AX Quality (not limited to only display in a Web browser), select MC Works64 CL RT
2. If an additional client license is needed for AX Energy, AX Facility, AX Quality (limited to display only in a Web browser), select MC Works64 CL RT
3. If an additional client is needed for AX Portal, select MC Works64 CL LT
4. If no additional clients are necessary, select "-".

## ■ Operation environment

### System requirements

| Item                                   | MC Works64<br>MC Graph64<br>MC Alarm64                       | MC Historian                   | MC Mobile                    | AX Energy<br>AX Facility<br>AX Quality<br>AX Portal  |
|--|--|--------------------------------|------------------------------|--|
| Series                                 | PC/AT-compatible personal computer                           |                                |                              |  |
| CPU                                    | Dual/Multi Core 64-bit processor 2 GHz or higher recommended |                                |                              |  |
| Memory                                 | 4 GB (8 GB or larger recommended)                            |                                |                              | 4 GB (10 GB or larger recommended)   |
| Hard disk drive (for installation)     | Free space of 4 GB or larger                                 | Free space of 160 GB or larger | Free space of 4 GB or larger | Free space of 20 GB or larger (50 GB or larger recommended)  |
| Virtual memory (for operation)         | 512 MB or larger   |                                |                              |  |
| Disk drive                             | DVD-ROM drive  |                                |                              |  |
| OS <sup>*1</sup>                       | 64-bit Windows® OS   |                                |                              |  |
| Display                                | Resolution : 1024 x 768 pixels or more                       |                                |                              |  |
| Database <sup>*1</sup>                 | Microsoft® SQL Server®                                       |                                |                              |  |
| .NET Framework                         | 4.5  |                                |                              |  |
| Web server <sup>*2</sup>               | Microsoft® Internet Information Services (IIS) 7.0 or later  |                                |                              |  |
| Web browser <sup>*1 *2</sup>           | Silverlight®-compatible browser (Internet Explorer® etc.)    |                                |                              |  |
| Other requirements                     | —  | —                              | —                            | Microsoft® SharePoint® Server 2012 <sup>*4</sup><br>Microsoft® SharePoint® Server 2010<br>and SharePoint® Foundation 2010 <sup>*4</sup><br>Microsoft® Office Excel®<br>(2003 or later) <sup>*3</sup> |
| PLC Engineering Software <sup>*5</sup> | GX Works2 (1.545T or later)<br>GX Works3 (1.025B or later)   | —                              | —                            | —  |

\*1: For the details of the compatibility with specific versions, see the table below.

\*2: Necessary to view browser screens

\*3: Necessary to use forms

\*4: Compatible with AX Portal

\*5: Necessary for automatically generating sequencer projects with MC AppBuilder

### OS compatibility

| OS                            | MC Works64<br>MC Graph64<br>MC Alarm64 | MC Historian | MC Mobile   | AX Energy<br>AX Facility<br>AX Quality<br>AX Portal |
|-------------------------------|--|--------------|---|---|
| Windows® 10 <sup>*1</sup>     | ●                                      | ●            | Server functionality required.<br>Can only be installed on Windows Server® system OS. |   |
| Windows® 8, 8.1 <sup>*1</sup> | ●                                      | ●            |   |   |
| Windows® 7 SP1 <sup>*2</sup>  | ●                                      | ●            |   |   |
| Windows Server® 2012R2        | ● <sup>*3</sup>                        | ●            | ●   | ●   |
| Windows Server® 2012          | ● <sup>*3</sup>                        | ●            | ●   | ●   |
| Windows Server® 2008R2 SP1    | ● <sup>*3</sup>                        | ●            | —   | ●   |
| Windows Server® 2008          | ● <sup>*3</sup>                        | ●            | —   | ●   |

\*1: Compatible with Pro and Enterprise editions

\*2: Compatible with Professional, Enterprise and Ultimate editions

\*3: MC AppBuilder will be operating out of warranty on a Windows Server® system OS.

### Database compatibility (data storage)

| Database                          | MC Works64<br>MC Graph64<br>MC Alarm64 | MC Historian | MC Mobile | AX Energy       | AX Facility<br>AX Quality<br>AX Portal |
|-----------------------------------|--|--------------|-----------|-----------------|--|
| SQL Server® 2014 <sup>*2</sup>    | ●                                      | ●            | ●         | ● <sup>*1</sup> | ●                                      |
| SQL Server® 2012 <sup>*2</sup>    | ●                                      | ●            | ●         | ● <sup>*1</sup> | ●                                      |
| SQL Server® 2008 R2 <sup>*2</sup> | ●                                      | ●            | ●         | ● <sup>*1</sup> | ●                                      |

\*1: When using AX Energy with SQL Server® Express, it will operate for 180 days in demo mode.

\*2: It is possible to use the Express (free) version of the software. However, please note that there are some restrictions in SQL Server® Express. (Database size: maximum 10GB. Please check Microsoft®'s home page for more information)

### Web browser compatibility (screen display)

| Web browser  | MC Works64<br>MC Graph64<br>MC Alarm64 | MC Historian    | MC Mobile | AX Energy<br>AX Facility<br>AX Quality<br>AX Portal |
|--|--|-----------------|-----------|---|
| Internet Explorer® 8-11                              | ●                                      | ●               | ●         | ●   |
| Firefox® 3 or later                                  | ● <sup>*1</sup>                        | ● <sup>*1</sup> | ●         | ●   |
| Safari®  | ● <sup>*1</sup>                        | ● <sup>*1</sup> | ●         | ●   |
| Google Chrome®                                       | —                                      | —               | ●         | ●   |
| Other web browsers<br>(compatible with Silverlight®) | ● <sup>*1</sup>                        | ● <sup>*1</sup> | —         | ●   |

\*1: Only the Silverlight®-version HMI screen is displayed.

■ Steps for starting up MC Works64

Registration of license (Software key)

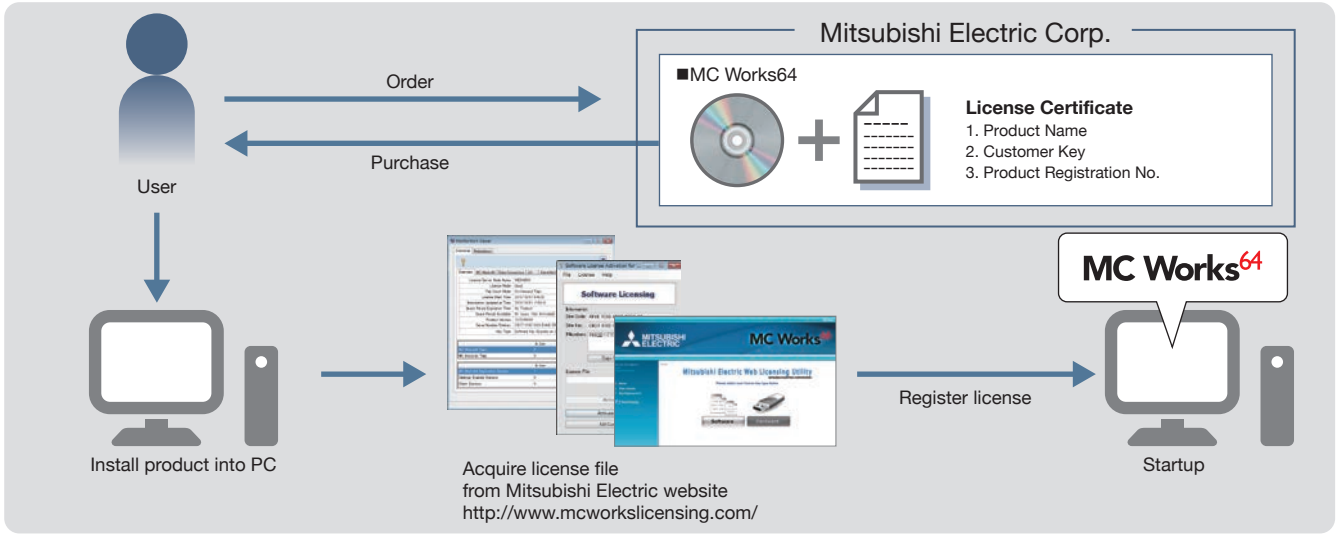

\* Refer to the manual enclosed with the product for details.

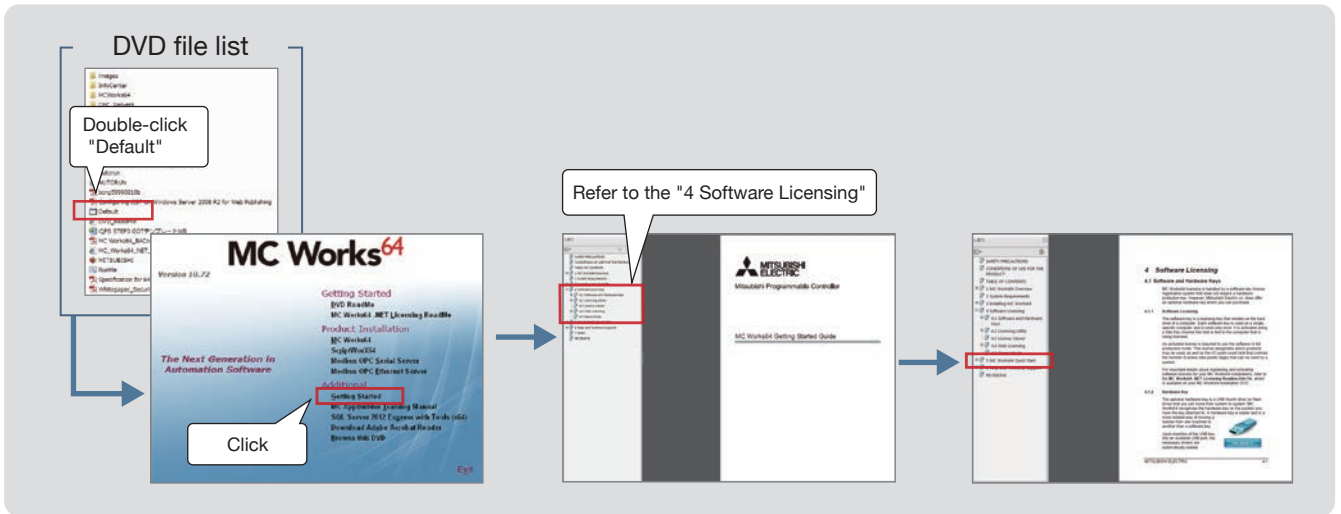

Registration of license (Hardware key)

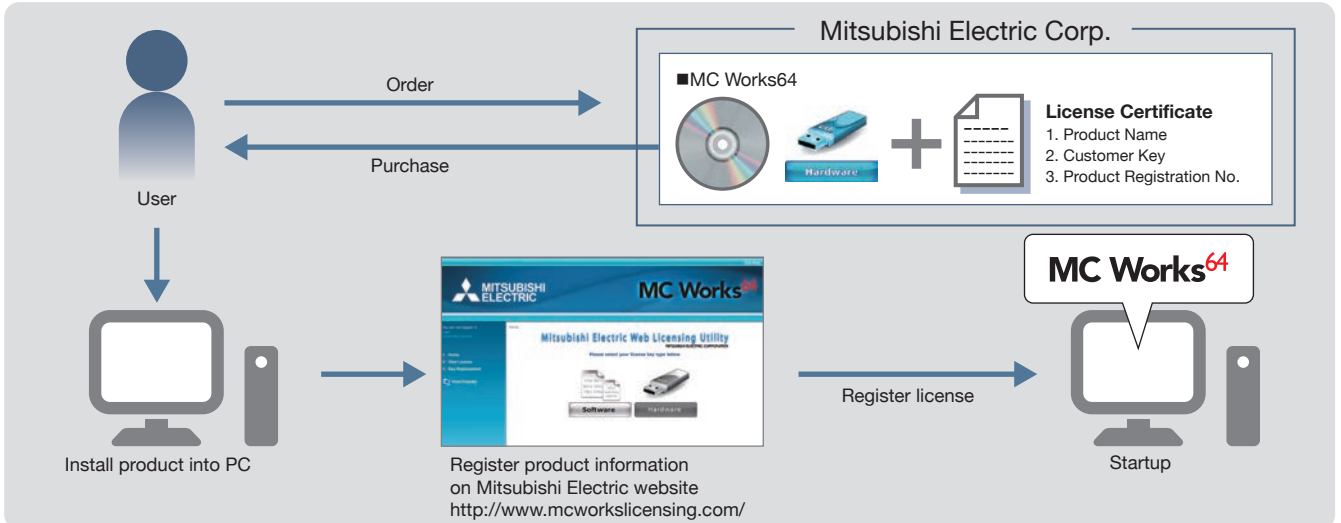

\* Refer to the manual enclosed with the product for details.

# Extensive global support coverage providing expert help whenever needed

## Global FA centers

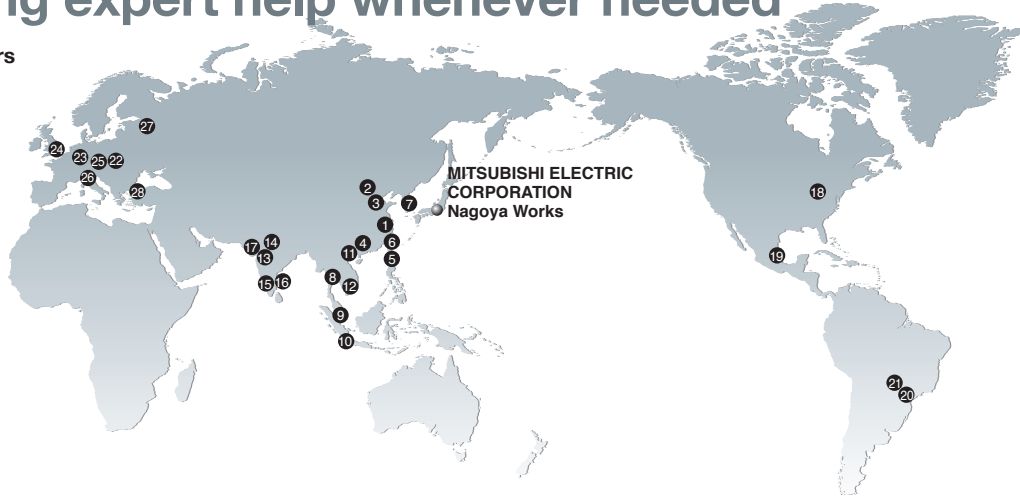

### China

#### 1 Shanghai FA Center

**MITSUBISHI ELECTRIC AUTOMATION (CHINA) LTD.**  
Mitsubishi Electric Automation Center, No. 1386 Hongqiao Road, Shanghai, China  
Tel: +86-21-2322-3030 / Fax: +86-21-2322-3000

#### 2 Beijing FA Center

**MITSUBISHI ELECTRIC AUTOMATION (CHINA) LTD. Beijing Branch**  
Unit 901, 9F, Office Tower 1, Henderson Centre, 18 Jianguomennei Avenue, Dongcheng District, Beijing, China  
Tel: +86-10-6518-8830 / Fax: +86-10-6518-2938

#### 3 Tianjin FA Center

**MITSUBISHI ELECTRIC AUTOMATION (CHINA) LTD. Tianjin Branch**  
Room 2003 City Tower, No.35, Youyi Road, Hexi District, Tianjin, China  
Tel: +86-22-2813-1015 / Fax: +86-22-2813-1017

#### 4 Guangzhou FA Center

**MITSUBISHI ELECTRIC AUTOMATION (CHINA) LTD. Guangzhou Branch**  
Room 1609, North Tower, The Hub Center, No.1068, Xingang East Road, Haizhu District, Guangzhou, China  
Tel: +86-20-8923-6730 / Fax: +86-20-8923-6715

### Taiwan

#### 5 Taichung FA Center

**MITSUBISHI ELECTRIC TAIWAN CO., LTD.**  
No.8-1, Industrial 16th Road, Taichung Industrial Park, Taichung City 40768, Taiwan  
Tel: +886-4-2359-0688 / Fax: +886-4-2359-0689

#### 6 Taipei FA Center

**SETSUYO ENTERPRISE CO., LTD.**  
3F, No.105, Wugong 3rd Road, Wugu District, New Taipei City 24889, Taiwan  
Tel: +886-2-2299-9917 / Fax: +886-2-2299-9963

### Korea

#### 7 Korea FA Center

**MITSUBISHI ELECTRIC AUTOMATION KOREA CO., LTD.**  
8F, Gangseo Hangang Xi-tower A, 401, Yangcheon-ro, Gangseo-Gu, Seoul 157-801, Korea  
Tel: +82-2-3660-9605 / Fax: +82-2-3663-0475

### Thailand

#### 8 Thailand FA Center

**MITSUBISHI ELECTRIC FACTORY AUTOMATION (THAILAND) CO., LTD.**  
12th Floor, SV.City Building, Office Tower 1, No. 896/19 and 20 Rama 3 Road, Kwaeng Bangpongpan, Khet Yannawa, Bangkok 10120, Thailand  
Tel: +66-2682-6522 / Fax: +66-2682-6020

### ASEAN

#### 9 ASEAN FA Center

**MITSUBISHI ELECTRIC ASIA PTE. LTD.**  
307, Alexandra Road, Mitsubishi Electric Building, Singapore 159943  
Tel: +65-6473-2308 / Fax: +65-6476-7439

### Indonesia

#### 10 Indonesia FA Center

**PT. MITSUBISHI ELECTRIC INDONESIA Cikarang Office**  
Jl. Kenari Raya Blok G2-07A Delta Silicon 5, Lippo Cikarang-Bekasi 17550, Indonesia  
Tel: +62-21-2961-7797 / Fax: +62-21-2961-7794

### Vietnam

#### 11 Hanoi FA Center

**MITSUBISHI ELECTRIC VIETNAM COMPANY LIMITED Hanoi Branch**  
6-Floor, Detech Tower, 8 Ton That Thuyet Street, My Dinh 2 Ward, Nam Tu Liem District, Hanoi, Vietnam  
Tel: +84-4-3937-8075 / Fax: +84-4-3937-8076

#### 12 Ho Chi Minh FA Center

**MITSUBISHI ELECTRIC VIETNAM COMPANY LIMITED**  
Unit 01-04, 10th Floor, Vincom Center, 72 Le Thanh Ton Street, District 1, Ho Chi Minh City, Vietnam  
Tel: +84-8-3910-5945 / Fax: +84-8-3910-5947

### India

#### 13 India Pune FA Center

**MITSUBISHI ELECTRIC INDIA PVT. LTD. Pune Branch**  
Emerald House, EL-3, J Block, M.I.D.C Bhosari, Pune-411026, Maharashtra, India  
Tel: +91-20-2710-2000 / Fax: +91-20-2710-2100

#### 14 India Gurgaon FA Center

**MITSUBISHI ELECTRIC INDIA PVT. LTD. Gurgaon Head Office**  
2nd Floor, Tower A & B, Cyber Greens, DLF Cyber City, DLF Phase-III, Gurgaon-122002 Haryana, India  
Tel: +91-124-463-0300 / Fax: +91-124-463-0399

#### 15 India Bangalore FA Center

**MITSUBISHI ELECTRIC INDIA PVT. LTD. Bangalore Branch**  
Prestige Emerald, 6th Floor, Municipal No. 2, Madras Bank Road (Lavelle Road), Bangalore-560001, Karnataka, India  
Tel: +91-80-4020-1600 / Fax: +91-80-4020-1699

#### 16 India Chennai FA Center

**MITSUBISHI ELECTRIC INDIA PVT. LTD. Chennai Branch**  
"Citilights Corporate Centre" No.1, Vivekananda Road, Srinivasa Nagar, Chetpet, Chennai-600031, Tamil Nadu, India  
Tel: +91-44-4554-8772 / Fax: +91-44-4554-8773

#### 17 India Ahmedabad FA Center

**MITSUBISHI ELECTRIC INDIA PVT. LTD. Ahmedabad Branch**  
B/4, 3rd Floor, Safal Profitaire, Corporate Road, Prahaladnagar, Satellite, Ahmedabad, Gujarat-380015, India  
Tel: +91-79-6512-0063

### America

#### 18 North America FA Center

**MITSUBISHI ELECTRIC AUTOMATION, INC.**  
500 Corporate Woods Parkway, Vernon Hills, IL 60061, U.S.A.  
Tel: +1-847-478-2100 / Fax: +1-847-478-2253

### Mexico

#### 19 Mexico FA Center

**MITSUBISHI ELECTRIC AUTOMATION, INC. Mexico Branch**  
Mariano Escobedo #69, Col. Zona Industrial, Tlalhepantla Edo, Mexico, C.P.54030  
Tel: +52-55-3067-7500

### Brazil

#### 20 Brazil FA Center

**MITSUBISHI ELECTRIC DO BRASIL COMÉRCIO E SERVIÇOS LTDA.**  
Avenida Adelino Cardana, 293 21 andar Bethaville, Barueri SP, Brasil  
Tel: +55-11-4689-3000 / Fax: +55-11-4689-3016

#### 21 Brazil Votorantim FA Center

**MELCO CNC DO BRASIL COMÉRCIO E SERVIÇOS S.A.**  
Av. Gisele Constantino, 1578, Parque Bela Vista, Votorantim-SP, Brasil CEP:18.110-650  
Tel: +55-15-3023-9000

### Europe

#### 22 Europe FA Center

**MITSUBISHI ELECTRIC EUROPE B.V. Polish Branch**  
ul. Krakowska 50, 32-083 Balice, Poland  
Tel: +48-12-347-65-00 / Fax: +48-12-630-47-01

#### 23 Germany FA Center

**MITSUBISHI ELECTRIC EUROPE B.V. German Branch**  
Mitsubishi-Electric-Platz 1, 40882 Ratingen, Germany  
Tel: +49-2102-486-0 / Fax: +49-2102-486-1120

#### 24 UK FA Center

**MITSUBISHI ELECTRIC EUROPE B.V. UK Branch**  
Travellers Lane, Hatfield, Hertfordshire, AL10 8XB, U.K.  
Tel: +44-1707-28-8780 / Fax: +44-1707-27-8695

#### 25 Czech Republic FA Center

**MITSUBISHI ELECTRIC EUROPE B.V. Czech Branch**  
Avenir Business Park, Radlicka 751/113e, 158 00 Praha5, Czech Republic  
Tel: +420-255-719-200

#### 26 Italy FA Center

**MITSUBISHI ELECTRIC EUROPE B.V. Italian Branch**  
Centro Direzionale Colleoni - Palazzo Sirio, Viale Colleoni 7, 20864 Agrate Brianza (Milano), Italy  
Tel: +39-039-605311 / Fax: +39-039-6053312

#### 27 Russia FA Center

**MITSUBISHI ELECTRIC EUROPE B.V. Russian Branch St. Petersburg office**  
Piskarevsky pr. 2, bld 2, lit "Sch", BC "Benua", office 720; 195027, St. Petersburg, Russia  
Tel: +7-812-633-3497 / Fax: +7-812-633-3499

#### 28 Turkey FA Center

**MITSUBISHI ELECTRIC TURKEY ELEKTRİK ÜRÜNLERİ A.Ş. Ümraniye Branch**  
Serifali Mahallesi Nutuk Sokak No:5, 34775 Ümraniye, Istanbul, Turkey  
Tel: +90-216-969-2500 / Fax: +90-216-526-3995



# CC-Link Partner Association (CLPA) - Actively promoting worldwide adoption of CC-Link networks

## Proactively supporting CC-Link, from promotion to specification development

The CC-Link Partner Association (CLPA) was established to promote the worldwide adoption of the CC-Link open-field network. By conducting promotional activities such as organizing trade shows and seminars, conducting conformance tests, and providing catalogs, brochures and website information, CLPA activities are successfully increasing the number of CC-Link partner manufacturers and CC-Link-compatible products. As such, CLPA is playing a major role in the globalization of CC-Link.



Seminar

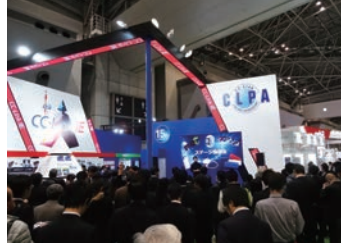

Trade show



Conformance testing lab

Visit the CLPA website for the latest CC-Link information.

URL: [www.cc-link.org](http://www.cc-link.org)



6F Ozone Front Bldg. 3-15-58 Ozone  
Kita-ku, Nagoya 462-0825, JAPAN  
TEL: +81-52-919-1588 FAX: +81-52-916-8655  
E-mail: [info@cc-link.org](mailto:info@cc-link.org)



## Global influence of CC-Link continues to spread

CC-Link is supported globally by CLPA. With offices throughout the world, support for partner companies can be found locally. Each regional CLPA office undertakes various support and promotional activities to further the influence of CC-Link/CC-Link IE in that part of the world. For companies looking to increase their presence in their local area, CLPA is well placed to assist these efforts through offices in all major regions.

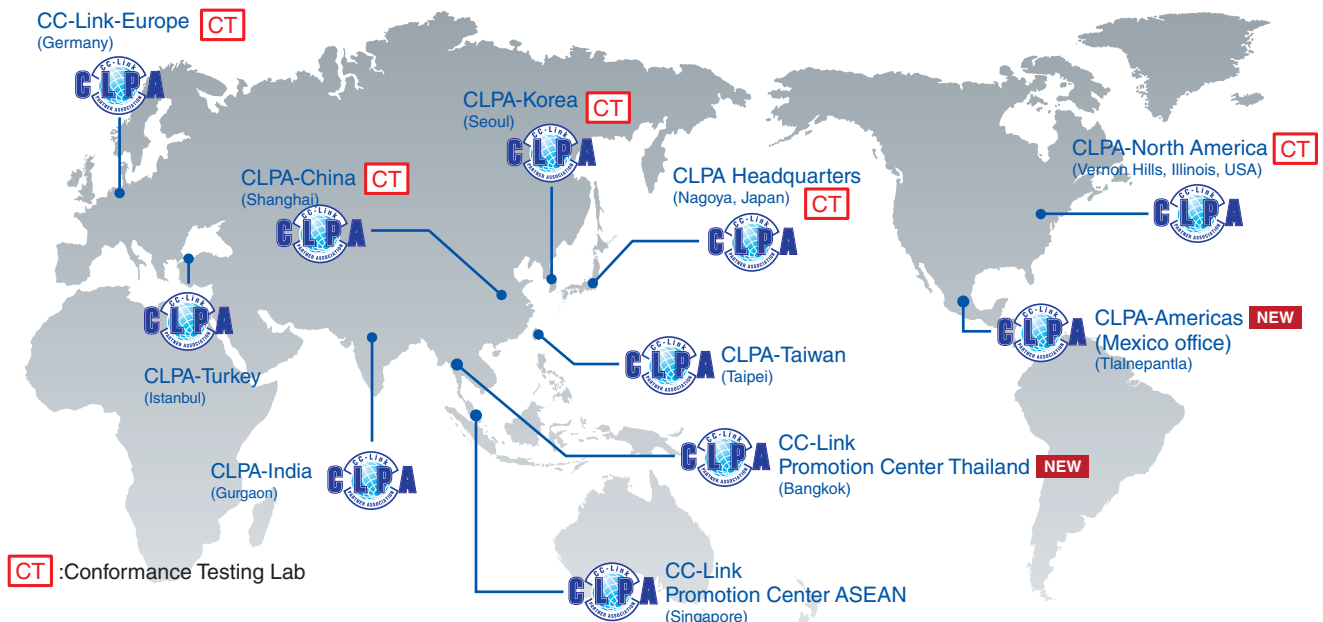

## Trademarks and Registered Trademarks

- Microsoft, Windows, Windows NT, Windows Server, Windows 2000, Windows 10, Windows 7, Windows 8, Windows 8.1, SQL Server, Microsoft Azure, Internet Explorer, Silverlight, SharePoint, ActiveX, Outlook, Excel, Visual Basic, Visio, Surface, Windows phone, and Bing are the registered trademarks or the trademarks of Microsoft Corporation in the US and in each country.
- Oracle and Java are the registered trademarks of Oracle Corporation, its subsidiaries, or its associates in the US and in other countries.
- Google, Android, Google Chrome and Google Play are the registered trademarks or the trademarks of Google Inc.
- Apple, Safari, iPhone, iPad, iPod touch, App Store and iOS are the registered trademarks or the trademarks of Apple Inc. in the US.
- IOS is a trademark or registered trademark of Cisco in the U.S. and other countries and is used under license.
- MySQL is either a registered trademark or a trademark of MySQL AB.
- Firefox is the trademark or the registered trademark of Mozilla Foundation in the US and in other countries.
- Esri is the registered trademark or the trademark of Esri in the US and in other countries.
- AutoCAD is the trademark or the registered trademark of Autodesk, Inc. in the US and in other countries.
- McAfee is the registered trademark or the trademark of McAfee, Inc., a corporation in the US, or its associates in the US or in other countries.
- Ethernet is the trademark of Xerox Corporation in the US.
- MODBUS is the registered trademark of Schneider Electric SA.
- Anywire is the registered trademark of Anywire Corporation.
- AnalytIX is the registered trademark of ICONICS, Inc.
- The other company names and product names described in this document are the trademarks or the registered trademarks of each of the companies.

# YOUR SOLUTION PARTNER

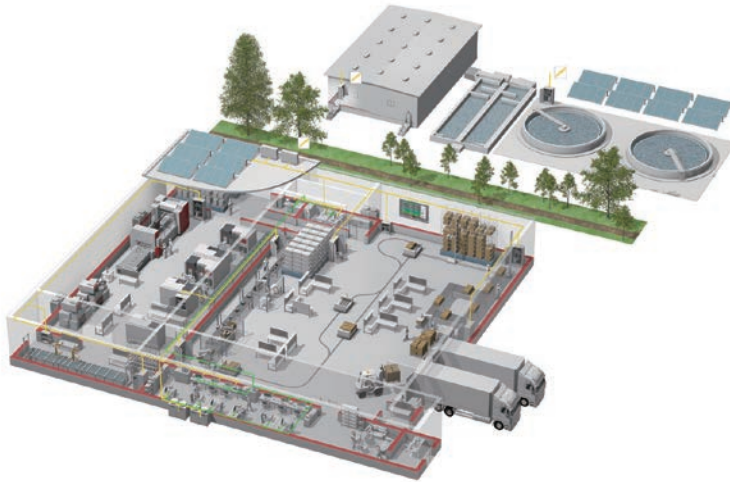

Mitsubishi Electric offers a wide range of automation equipment from PLCs and HMIs to CNC and EDM machines.

## A NAME TO TRUST

Since its beginnings in 1870, some 45 companies use the Mitsubishi name, covering a spectrum of finance, commerce and industry.

The Mitsubishi brand name is recognized around the world as a symbol of premium quality.

Mitsubishi Electric Corporation is active in space development, transportation, semi-conductors, energy systems, communications and information processing, audio visual equipment and home electronics, building and energy management and automation systems, and has 237 factories and laboratories worldwide in over 121 countries.

This is why you can rely on Mitsubishi Electric automation solution - because we know first hand about the need for reliable, efficient, easy-to-use automation and control in our own factories.

As one of the world's leading companies with a global turnover of over 4 trillion Yen (over \$40 billion), employing over 100,000 people, Mitsubishi Electric has the resource and the commitment to deliver the ultimate in service and support as well as the best products.

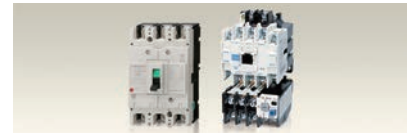

Low voltage: MCCB, MCB, ACB



Medium voltage: VCB, VCC



Power monitoring, energy management



Compact and Modular Controllers



Inverters, Servos and Motors



Visualisation: HMIs



Numerical Control (NC)



Robots: SCARA, Articulated arm



Processing machines: EDM, Lasers, IDS



Transformers, Air conditioning, Photovoltaic systems

\* Not all products are available in all countries.

| Country/Region | Sales office  | Tel/Fax  |
|----------------|---|--|
| USA            | MITSUBISHI ELECTRIC AUTOMATION, INC.<br>500 Corporate Woods Parkway, Vernon Hills, IL 60061, U.S.A.   | Tel : +1-847-478-2100<br>Fax : +1-847-478-2253     |
| Mexico         | MITSUBISHI ELECTRIC AUTOMATION, INC. Mexico Branch<br>Mariano Escobedo #69, Col. Zona Industrial, Tlalnepantla Edo. Mexico, C.P.54030   | Tel : +52-55-3067-7500                             |
| Brazil         | MITSUBISHI ELECTRIC DO BRASIL COMÉRCIO E SERVIÇOS LTDA.<br>Avenida Adelino Cardana, 293, 21 andar, Bethaville, Barueri SP, Brazil   | Tel : +55-11-4689-3000<br>Fax : +55-11-4689-3016   |
| Germany        | MITSUBISHI ELECTRIC EUROPE B.V. German Branch<br>Mitsubishi-Electric-Platz 1, 40882 Ratingen, Germany   | Tel : +49-2102-486-0<br>Fax : +49-2102-486-1120    |
| UK             | MITSUBISHI ELECTRIC EUROPE B.V. UK Branch<br>Travellers Lane, Hatfield, Hertfordshire, AL10 8XB, U.K.   | Tel : +44-1707-28-8780<br>Fax : +44-1707-27-8695   |
| Ireland        | MITSUBISHI ELECTRIC EUROPE B.V. Irish Branch<br>Westgate Business Park, Ballymount, Dublin 24, Ireland  | Tel : +353-1-4198800<br>Fax : +353-1-4198890       |
| Italy          | MITSUBISHI ELECTRIC EUROPE B.V. Italian Branch<br>Centro Direzionale Colleoni-Palazzo Sirio Viale Colleoni 7, 20864 Agrate Brianza(Milano) Italy  | Tel : +39-039-60531<br>Fax : +39-039-6053-312      |
| Spain          | MITSUBISHI ELECTRIC EUROPE, B.V. Spanish Branch<br>Carretera de Rubí, 76-80-Apdo. 420, 08190 Sant Cugat del Vallés (Barcelona), Spain   | Tel : +34-935-65-3131<br>Fax : +34-935-89-1579     |
| France         | MITSUBISHI ELECTRIC EUROPE B.V. French Branch<br>25, Boulevard des Bouvets, 92741 Nanterre Cedex, France  | Tel : +33-1-55-68-55-68<br>Fax : +33-1-55-68-57-57 |
| Czech Republic | MITSUBISHI ELECTRIC EUROPE B.V. Czech Branch<br>Avenir Business Park, Radlicka 751/113e, 158 00 Praha5, Czech Republic  | Tel : +420-251-551-470<br>Fax : +420-251-551-471   |
| Poland         | MITSUBISHI ELECTRIC EUROPE B.V. Polish Branch<br>ul. Krakowska 50, 32-083 Balice, Poland  | Tel : +48-12-347-65-00<br>Fax : +48-12-630-47-01   |
| Sweden         | MITSUBISHI ELECTRIC EUROPE B.V. (Scandinavia)<br>Fjellievägen 8, SE-22736 Lund, Sweden  | Tel : +46-8-625-10-00<br>Fax : +46-46-39-70-18     |
| Russia         | MITSUBISHI ELECTRIC (RUSSIA) LLC St. Petersburg Branch<br>Piskarevsky pr. 2, bld 2, lit "Sch", BC "Benua", office 720; 195027 St. Petersburg, Russia  | Tel : +7-812-633-3497<br>Fax : +7-812-633-3499     |
| Turkey         | MITSUBISHI ELECTRIC TURKEY A.Ş Ümraniye Branch<br>Serifali Mahallesi Nutuk Sokak No:5, TR-34775 Umraniye/Istanbul, Turkey   | Tel : +90-216-526-3990<br>Fax : +90-216-526-3995   |
| UAE            | MITSUBISHI ELECTRIC EUROPE B.V. Dubai Branch<br>Dubai Silicon Oasis, P.O.BOX 341241, Dubai, U.A.E.  | Tel : +971-4-3724716<br>Fax : +971-4-3724721       |
| South Africa   | ADROIT TECHNOLOGIES<br>20 Waterford Office Park, 189 Witkoppen Road, Fourways, South Africa   | Tel : +27-11-658-8100<br>Fax : +27-11-658-8101     |
| China          | MITSUBISHI ELECTRIC AUTOMATION (CHINA) LTD.<br>No.1386 Hongqiao Road, Mitsubishi Electric Automation Center, Shanghai, China  | Tel : +86-21-2322-3030<br>Fax : +86-21-2322-3000   |
| Taiwan         | SETSUYO ENTERPRISE CO., LTD.<br>6F, No.105, Wugong 3rd Road, Wugu District, New Taipei City 24889, Taiwan   | Tel : +886-2-2299-2499<br>Fax : +886-2-2299-2509   |
| Korea          | MITSUBISHI ELECTRIC AUTOMATION KOREA CO., LTD.<br>7F-9F, Gangseo Hangang Xi-tower A, 401, Yangcheon-ro, Gangseo-Gu, Seoul 07528, Korea  | Tel : +82-2-3660-9530<br>Fax : +82-2-3664-8372     |
| Singapore      | MITSUBISHI ELECTRIC ASIA PTE. LTD.<br>307, Alexandra Road, Mitsubishi Electric Building, Singapore 159943   | Tel : +65-6473-2308<br>Fax : +65-6476-7439         |
| Thailand       | MITSUBISHI ELECTRIC FACTORY AUTOMATION (THAILAND) CO., LTD.<br>12th Floor, SV.City Building, Office Tower 1, No. 896/19 and 20 Rama 3 Road, Kwaeng Bangpongpan, Khet Yannawa, Bangkok 10120, Thailand | Tel : +66-2682-6522<br>Fax : +66-2682-6020         |
| Vietnam        | MITSUBISHI ELECTRIC VIETNAM COMPANY LIMITED Hanoi Branch<br>6th Floor, Detch Tower, 8 Ton That Thuyet Street, My Dinh 2 Ward, Nam Tu Liem District, Hanoi, Vietnam                                    | Tel : +84-4-3937-8075<br>Fax : +84-4-3937-8076     |
| Indonesia      | PT. MITSUBISHI ELECTRIC INDONESIA<br>Gedung Jaya 11th Floor, JL. MH. Thamrin No.12, Jakarta Pusat 10340, Indonesia  | Tel : +62-21-3192-6461<br>Fax : +62-21-3192-3942   |
| India          | MITSUBISHI ELECTRIC INDIA PVT. LTD. Pune Branch<br>Emerald House, EL-3, J Block, M.I.D.C., Bhosari, Pune-411026, Maharashtra, India   | Tel : +91-20-2710-2000<br>Fax : +91-20-2710-2100   |
| Australia      | MITSUBISHI ELECTRIC AUSTRALIA PTY. LTD.<br>348 Victoria Road, P.O. Box 11, Rydalmere, N.S.W 2116, Australia   | Tel : +61-2-9684-7777<br>Fax : +61-2-9684-7245     |

Mitsubishi Electric Corporation Nagoya Works is a factory certified for ISO 14001 (standards for environmental management systems) and ISO 9001 (standards for quality assurance management systems).

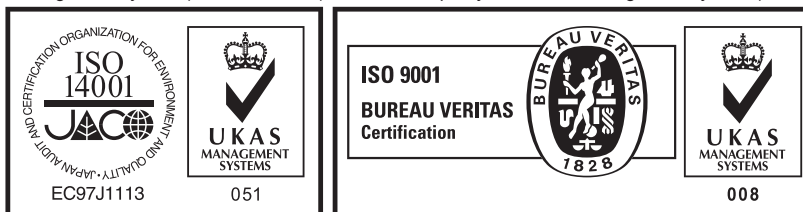

## MITSUBISHI ELECTRIC CORPORATION

HEAD OFFICE: TOKYO BLDG., 2-7-3, MARUNOUCHI, CHIYODA-KU, TOKYO 100-8310, JAPAN  
[www.MitsubishiElectric.com](http://www.MitsubishiElectric.com)