

Machine Automation Controller NJ/NX-series

Instructions Reference Manual

NX701-17□□

NX701-16□□

NX1P2-11□□□□

NX1P2-10□□□□

NX1P2-90□□□□

NJ501-□5□□

NJ501-□4□□

NJ501-□3□□

NJ301-12□□

NJ301-11□□

NJ101-10□□

NJ101-90□□

NOTE

All rights reserved. No part of this publication may be reproduced, stored in a retrieval system, or transmitted, in any form, or by any means, mechanical, electronic, photocopying, recording, or otherwise, without the prior written permission of OMRON.

No patent liability is assumed with respect to the use of the information contained herein. Moreover, because OMRON is constantly striving to improve its high-quality products, the information contained in this manual is subject to change without notice. Every precaution has been taken in the preparation of this manual. Nevertheless, OMRON assumes no responsibility for errors or omissions. Neither is any liability assumed for damages resulting from the use of the information contained in this publication.

Trademarks

- Sysmac and SYSMAC are trademarks or registered trademarks of OMRON Corporation in Japan and other countries for OMRON factory automation products.
- Microsoft, Windows, Windows Vista, Excel, and Visual Basic are either registered trademarks or trademarks of Microsoft Corporation in the United States and other countries.
- EtherCAT® is registered trademark and patented technology, licensed by Beckhoff Automation GmbH, Germany.
- ODVA, CIP, CompoNet, DeviceNet, and EtherNet/IP are trademarks of ODVA.
- The SD and SDHC logos are trademarks of SD-3C, LLC. 

Other company names and product names in this document are the trademarks or registered trademarks of their respective companies.

Copyrights

Microsoft product screen shots reprinted with permission from Microsoft Corporation.

Introduction

Thank you for purchasing an NJ/NX-series CPU Unit.

This manual contains information that is necessary to use the NJ/NX-series CPU Unit. Please read this manual and make sure you understand the functionality and performance of the NJ/NX-series CPU Unit before you attempt to use it in a control system.

Keep this manual in a safe place where it will be available for reference during operation.

Intended Audience

This manual is intended for the following personnel, who must also have knowledge of electrical systems (an electrical engineer or the equivalent).

- Personnel in charge of introducing FA systems.
- Personnel in charge of designing FA systems.
- Personnel in charge of installing and maintaining FA systems.
- Personnel in charge of managing FA systems and facilities.

For programming, this manual is intended for personnel who understand the programming language specifications in international standard IEC 61131-3 or Japanese standard JIS B 3503.

Applicable Products

This manual covers the following products.

- NX-series CPU Units
 - NX701-17□□
 - NX701-16□□
 - NX1P2-11□□□□
 - NX1P2-11□□□□1
 - NX1P2-10□□□□
 - NX1P2-10□□□□1
 - NX1P2-90□□□□
 - NX1P2-90□□□□1
- NJ-series CPU Units
 - NJ501-□5□□
 - NJ501-□4□□
 - NJ501-□3□□
 - NJ301-12□□
 - NJ301-11□□
 - NJ101-10□□
 - NJ101-90□□

Part of the specifications and restrictions for the CPU Units are given in other manuals. Refer to *Relevant Manuals* on page 2 and *Related Manuals* on page 28.

Relevant Manuals

The following table provides the relevant manuals for the NJ/NX-series CPU Units. Read all of the manuals that are relevant to your system configuration and application before you use the NJ/NX-series CPU Unit.

Most operations are performed from the Sysmac Studio Automation Software. Refer to the *Sysmac Studio Version 1 Operation Manual* (Cat. No. W504) for information on the Sysmac Studio.

Purpose of use	Manual													
	Basic information				NJ/NX-series Instructions Reference Manual	NJ/NX-series CPU Unit Motion Control User's Manual	Motion Control Instructions Reference Manual	NJ/NX-series CPU Unit Built-in EtherCAT Port User's Manual	NJ/NX-series CPU Unit Built-in EtherNet/IP Port User's Manual	NJ-series Database Connection CPU Units User's Manual	NJ-series SECS/GEM CPU Units User's Manual	NJ-series NJ Robotics CPU Unit User's Manual	NC Integrated Controller User's Manual	NJ/NY-series Troubleshooting Manual
	NJ-series CPU Unit Hardware User's Manual	NX-series NX1P2 CPU Unit Hardware User's Manual	NX-series CPU Unit Hardware User's Manual	NJ/NX-series CPU Unit Software User's Manual										
Introduction to NX701 CPU Units	●													
Introduction to NX1P2 CPU Units		●												
Introduction to NJ-series Controllers			●											
Setting devices and hardware	●	●	●											
Using motion control					●									
Using EtherCAT							●							
Using EtherNet/IP								●						
Software settings				●										
Using motion control					●									
Using EtherCAT							●							
Using EtherNet/IP								●						
Using the database connection service									●					
Using the GEM Services										●				
Using robot control											●			
Using numerical control												●		
Using the NX1P2 CPU Unit functions					●								●	
Writing the user program				●		●								
Using motion control						●	●							
Using EtherCAT								●						
Using EtherNet/IP									●					
Using the database connection service										●				
Using the GEM Services											●			
Using robot control												●		
Using numerical control													●	
Programming error processing														●
Using the NX1P2 CPU Unit functions					●									

Purpose of use	Manual														
	Basic Information														
	NX-series CPU Unit Hardware User's Manual	NX-series NX1P2 CPU Unit Hardware User's Manual	NJ-series CPU Unit Hardware User's Manual	NJ/NX-series CPU Unit Software User's Manual	NX-series NX1P2 CPU Unit Built-in I/O and Option Board User's Manual	NJ/NX-series Instructions Reference Manual	NJ/NX-series Motion Control User's Manual	NJ/NX-series Motion Control Instructions Reference Manual	NJ/NX-series CPU Unit Built-in EtherCAT Port User's Manual	NJ/NX-series CPU Unit Built-in EtherNet/IP Port User's Manual	NJ-series Database Connection CPU Units User's Manual	NJ-series SECS/GEM CPU Units User's Manual	NJ-series NJ Robotics CPU Unit User's Manual	NJ/NY-series NC Integrated Controller User's Manual	NJ/NX-series Troubleshooting Manual
Testing operation and debugging				●											
Using motion control							●								
Using EtherCAT									●						
Using EtherNet/IP									●						
Using the database connection service										●					
Using the GEM Services											●				
Using robot control												●			
Using numerical control													●		
Using the NX1P2 CPU Unit functions					●										
Learning about error management and corrections *1	▲	▲	▲	▲	▲		▲		▲	▲	▲	▲	▲	▲	●
Maintenance															
Using motion control	●	●	●				●								
Using EtherCAT									●						
Using EtherNet/IP									●						

*1 Refer to the *NJ/NX-series Troubleshooting Manual* (Cat. No. W503) for the error management concepts and an overview of the error items. Refer to the manuals that are indicated with triangles for details on errors for the corresponding Units.

Manual Structure

Page Structure

The following page structure is used in this manual.

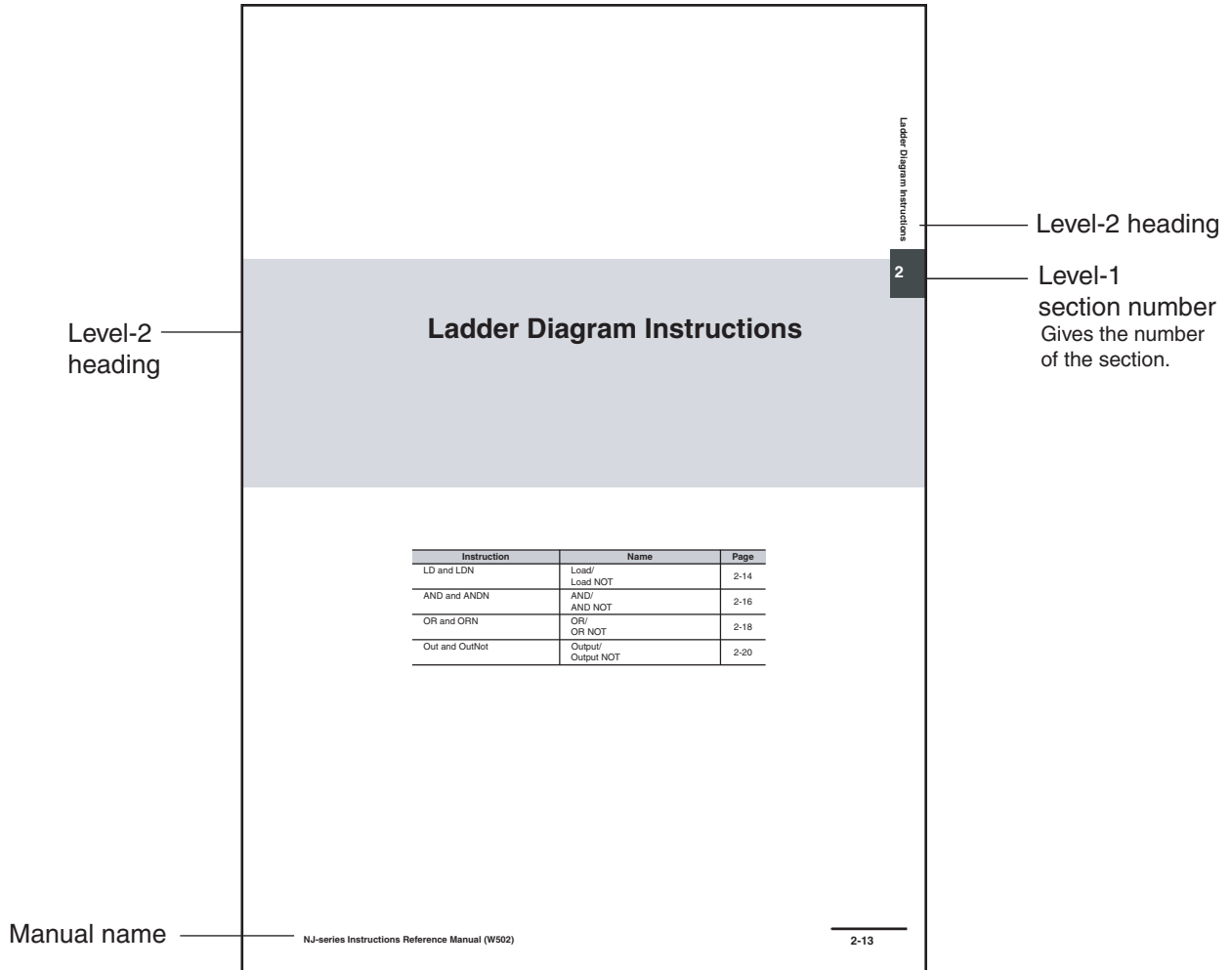

This page is for illustration only. It may not literally appear in this manual.

Level-3 heading

2 Instruction Descriptions

OR and ORN

OR: Takes the logical OR of the value of a BOOL variable and the execution condition.
 ORN: Takes the logical OR of the inverse of the value of a BOOL variable and the execution condition.

Instruction	Name	FB/FUN	Graphic expression	ST expression
OR	OR	---		result=vBool1 OR vBool2;
ORN	OR NOT	---		result=vBool1 OR NOT vBool2;

Variables
None

Function

- OR**
 The OR instruction takes the logical OR of the value of a specified BOOL variable and the execution condition and outputs it to the next instruction. Use the OR instruction for a NO bit connected in parallel with the previous instruction. Use the OR instruction to configure a logical OR between an NO bit and one of the following: a LD or LDN instruction connected directly to the bus bar, or the logic block starting with a LD or LDN instruction and ending with the instruction immediately before the OR instruction.
- ORN**
 The ORN instruction takes the logical OR of the inverse of the value of a specified BOOL variable and the execution condition and outputs it to the next instruction. Use the ORN instruction for a NC bit connected in parallel with the previous instruction. Use the ORN instruction to configure a logical OR between an NC bit and one of the following: a LD or LDN instruction connected directly to the bus bar, or the logic block starting with a LD or LDN instruction and ending with the instruction immediately before the ORN instruction.

The following figure shows a programming example of the OR instruction. It takes the logical OR of variable A and variable B and outputs it to variable C.

Ladder Diagram Instructions
2
OR and ORN

NJ-series Instructions Reference Manual (W502) 2-17

Level-1 heading

Level-2 heading

Level-3 heading

Give the current headings.

Level-1 section number

2 Gives the number of the section.

Manual name

This page is for illustration only. It may not literally appear in this manual.

Special Information

Special information in this manual is classified as follows:



Precautions for Correct Use

Precautions on what to do and what not to do to ensure proper operation and performance.



Additional Information

Additional information to read as required.

This information is provided to increase understanding or make operation easier.

Note References are provided to more detailed or related information.



Version Information

Information on differences in specifications and functionality for CPU Units with different unit versions and for different versions of the Sysmac Studio are given.

Sections in this Manual

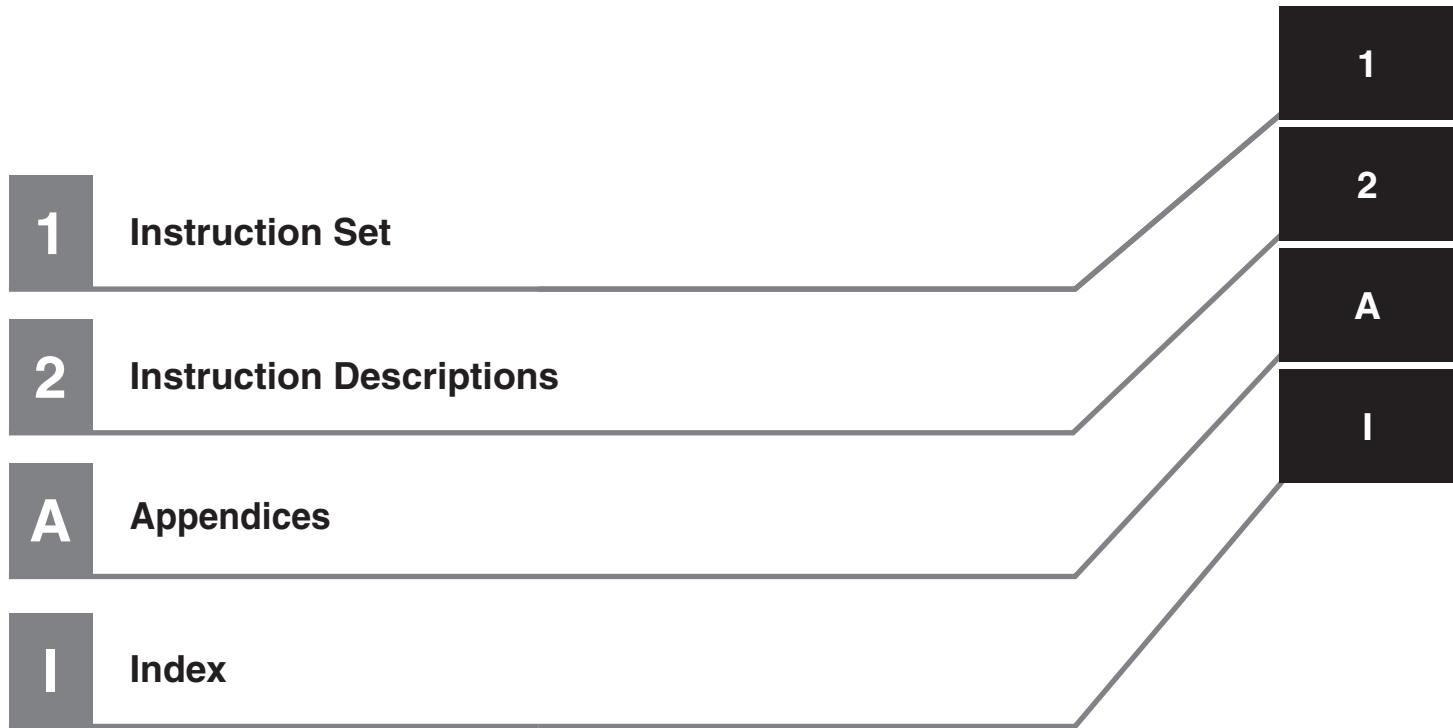

CONTENTS

Introduction	1
Relevant Manuals.....	2
Manual Structure	4
Sections in this Manual.....	7
Terms and Conditions Agreement	17
Safety Precautions	19
Precautions for Safe Use	20
Precautions for Correct Use	21
Regulations and Standards	22
Versions.....	24
Related Manuals	28
Revision History	31

Section 1 Instruction Set

Instruction Set	1-2
-----------------------	-----

Section 2 Instruction Descriptions

Using this Section	2-3
Ladder Diagram Instructions	2-15
LD and LDN	2-16
AND and ANDN	2-18
OR and ORN	2-20
Out and OutNot	2-22
ST Statement Instructions	2-25
IF	2-26
CASE	2-30
WHILE	2-34
REPEAT	2-36
EXIT	2-38
RETURN	2-41
FOR	2-42
Sequence Input Instructions	2-43
R_TRIG (Up) and F_TRIG (Down)	2-44
TestABit and TestABitN	2-47
Sequence Output Instructions	2-49
RS	2-50
SR	2-53
Set and Reset	2-56
SetBits and ResetBits	2-59
SetABit and ResetABit	2-61

OutABit	2-63
Sequence Control Instructions	2-65
End	2-66
RETURN	2-67
MC and MCR	2-68
JMP	2-80
FOR and NEXT	2-82
BREAK	2-89
Comparison Instructions	2-91
EQ (=)	2-92
NE (<>)	2-94
LT (<), LE (<=), GT (>), and GE (>=)	2-97
EQascii	2-100
NEascii	2-102
LTascii, LEascii, GTascii, and GEascii	2-104
Cmp	2-107
ZoneCmp	2-109
TableCmp	2-111
AryCmpEQ and AryCmpNE	2-114
AryCmpLT, AryCmpLE, AryCmpGT, and AryCmpGE	2-116
AryCmpEQV and AryCmpNEV	2-119
AryCmpLTV, AryCmpLEV, AryCmpGTV, and AryCmpGEV	2-121
Timer Instructions	2-125
TON	2-126
TOF	2-132
TP	2-135
AccumulationTimer	2-138
Timer	2-141
Counter Instructions	2-145
CTD	2-146
CTD_**	2-148
CTU	2-150
CTU_**	2-152
CTUD	2-155
CTUD_**	2-159
Math Instructions	2-165
ADD (+)	2-166
AddOU (+OU)	2-170
SUB (-)	2-174
SubOU (-OU)	2-177
MUL (*)	2-181
MulOU (*OU)	2-185
DIV (/)	2-189
MOD	2-192
ABS	2-194
RadToDeg and DegToRad	2-196
SIN, COS, and TAN	2-198
ASIN, ACOS, and ATAN	2-201
SQRT	2-204
LN and LOG	2-206
EXP	2-209
EXPT (**)	2-211
Inc and Dec	2-217
Rand	2-219
AryAdd	2-221
AryAddV	2-223
ArySub	2-225
ArySubV	2-227

AryMean	2-229
ArySD	2-231
ModReal	2-233
Fraction	2-235
CheckReal	2-237
BCD Conversion Instructions	2-241
_BCD_TO_	2-242
_TO_BCD_	2-245
BCD_TO_**	2-247
BCDsToBin	2-250
BinToBCDs_**	2-253
AryToBCD	2-256
AryToBin	2-258
Data Type Conversion Instructions	2-261
TO (Integer-to-Integer Conversion Group)	2-262
TO (Integer-to-Bit String Conversion Group)	2-265
TO (Integer-to-Real Number Conversion Group)	2-268
TO (Bit String-to-Integer Conversion Group)	2-270
TO (Bit String-to-Bit String Conversion Group)	2-272
TO (Bit String-to-Real Number Conversion Group)	2-274
TO (Real Number-to-Integer Conversion Group)	2-276
TO (Real Number-to-Bit String Conversion Group)	2-279
TO (Real Number-to-Real Number Conversion Group)	2-281
**_TO_STRING (Integer-to-Text String Conversion Group)	2-283
**_TO_STRING (Bit String-to-Text String Conversion Group)	2-285
**_TO_STRING (Real Number-to-Text String Conversion Group)	2-287
RealToFormatString	2-289
LrealToFormatString	2-294
STRING_TO_** (Text String-to-Integer Conversion Group)	2-299
STRING_TO_** (Text String-to-Bit String Conversion Group)	2-301
STRING_TO_** (Text String-to-Real Number Conversion Group)	2-303
TO_** (Integer Conversion Group)	2-306
TO_** (Bit String Conversion Group)	2-308
TO_** (Real Number Conversion Group)	2-310
EnumToNum	2-312
NumToEnum	2-314
TRUNC, Round, and RoundUp	2-316
Bit String Processing Instructions	2-319
AND (&), OR, and XOR	2-320
XORN	2-323
NOT	2-325
AryAnd, AryOr, AryXor, and AryXorN	2-327
Selection Instructions	2-331
SEL	2-332
MUX	2-334
LIMIT	2-337
Band	2-339
Zone	2-342
MAX and MIN	2-345
AryMax and AryMin	2-347
ArySearch	2-350
Data Movement Instructions	2-353
MOVE	2-354
MoveBit	2-357
MoveDigit	2-359
TransBits	2-361
MemCopy	2-363
SetBlock	2-365

Exchange	2-367
AryExchange	2-369
AryMove	2-371
Clear	2-373
Copy**ToNum (Bit String to Signed Integer)	2-375
Copy**To*** (Bit String to Real Number)	2-377
CopyNumTo** (Signed Integer to Bit String)	2-379
CopyNumTo** (Signed Integer to Real Number)	2-381
Copy**To*** (Real Number to Bit String)	2-383
Copy**ToNum (Real Number to Signed Integer)	2-385
Shift Instructions	2-387
AryShiftReg	2-388
AryShiftRegLR	2-390
ArySHL and ArySHR	2-393
SHL and SHR	2-396
NSHLC and NSHRC	2-398
ROL and ROR	2-400
Conversion Instructions	2-403
Swap	2-404
Neg	2-405
Decoder	2-407
Encoder	2-410
BitCnt	2-412
ColmToLine_**	2-413
LineToColm	2-415
Gray	2-417
UTF8ToSJIS	2-422
SJISToUTF8	2-424
PWLAprox and PWLAproxNoLineChk	2-426
PWLLineChk	2-432
MovingAverage	2-435
DispartReal	2-441
UniteReal	2-444
NumToDecString and NumToHexString	2-446
HexStringToNum_**	2-449
FixNumToString	2-451
StringToFixNum	2-453
DtToString	2-456
DateToString	2-458
TodToString	2-459
GrayToBin_** and BinToGray_**	2-461
StringToAry	2-463
AryToString	2-465
DispartDigit	2-467
UniteDigit_**	2-469
Dispart8Bit	2-471
Unite8Bit_**	2-473
ToAryByte	2-475
AryByteTo	2-480
SizeOfAry	2-485
PackWord	2-487
PackDword	2-489
Stack and Table Instructions	2-491
StackPush	2-492
StackFIFO and StackLIFO	2-501
StackIns	2-504
StackDel	2-506
RecSearch	2-508
RecRangeSearch	2-513

RecSort	2-518
RecNum	2-524
RecMax and RecMin	2-526
FCS Instructions	2-531
StringSum	2-532
StringLRC	2-534
StringCRCCCITT	2-536
StringCRC16	2-538
AryLRC_**	2-540
AryCRCCCITT	2-542
AryCRC16	2-544
Text String Instructions	2-547
CONCAT	2-548
LEFT and RIGHT	2-550
MID	2-552
FIND	2-554
LEN	2-556
REPLACE	2-557
DELETE	2-559
INSERT	2-561
GetByteLen	2-563
ClearString	2-565
ToUCase and ToLCase	2-567
TrimL and TrimR	2-569
AddDelimiter	2-571
SubDelimiter	2-582
Time and Time of Day Instructions	2-593
ADD_TIME	2-594
ADD_TOD_TIME	2-596
ADD_DT_TIME	2-598
SUB_TIME	2-600
SUB_TOD_TIME	2-602
SUB_TOD_TOD	2-604
SUB_DATE_DATE	2-605
SUB_DT_DT	2-606
SUB_DT_TIME	2-608
MULTIME	2-610
DIVTIME	2-612
CONCAT_DATE_TOD	2-614
DT_TO_TOD	2-616
DT_TO_DATE	2-618
SetTime	2-620
GetTime	2-622
DtToSec	2-624
DateToSec	2-626
TodToSec	2-627
SecToDt	2-628
SecToDate	2-630
SecToTod	2-632
TimeToNanoSec	2-634
TimeToSec	2-635
NanoSecToTime	2-636
SecToTime	2-637
ChkLeapYear	2-639
GetDaysOfMonth	2-640
DaysToMonth	2-642
GetDayOfWeek	2-644
GetWeekOfYear	2-646
DtToDateStruct	2-648

DateStructToDt	2-650
TruncTime	2-652
TruncDt	2-656
TruncTod	2-660
Analog Control Instructions	2-665
PIDAT	2-666
PIDAT_HeatCool	2-691
TimeProportionalOut	2-729
LimitAlarm_**	2-745
LimitAlarmDv_**	2-749
LimitAlarmDvStbySeq_**	2-754
ScaleTrans	2-769
AC_StepProgram	2-772
System Control Instructions	2-797
TraceSamp	2-798
TraceTrig	2-801
GetTraceStatus	2-804
SetAlarm	2-808
ResetAlarm	2-813
GetAlarm	2-815
ResetPLCError	2-817
GetPLCError	2-820
ResetCJBError	2-822
GetCJBError	2-824
GetEIPErr	2-826
ResetMCErr	2-828
GetMCErr	2-833
ResetECErr	2-835
GetECErr	2-837
ResetNXBError	2-840
GetNXBError	2-842
GetNXUnitError	2-844
SetInfo	2-852
ResetUnit	2-854
GetNTPStatus	2-858
RestartNXUnit	2-860
NX_ChangeWriteMode	2-866
NX_SaveParam	2-871
NX_ReadTotalPowerOnTime	2-877
PLC_ReadTotalPowerOnTime	2-885
Program Control Instructions	2-889
PrgStart	2-890
PrgStop	2-899
PrgStatus	2-919
EtherCAT Communications Instructions	2-925
EC_CoESDOWrite	2-926
EC_CoESDORead	2-929
EC_StartMon	2-934
EC_StopMon	2-940
EC_SaveMon	2-942
EC_CopyMon	2-944
EC_DisconnectSlave	2-946
EC_ConnectSlave	2-953
EC_ChangeEnableSetting	2-955
NX_WriteObj	2-972
NX_ReadObj	2-987
IO-Link Communications Instruction	2-997
IOL_ReadObj	2-998

IOL_WriteObj	2-1007
EtherNet/IP Communications Instructions	2-1017
CIPOpen	2-1018
CIPOpenWithDataSize	2-1027
CIPRead	2-1031
CIPWrite	2-1037
CIPSend	2-1043
CIPCclose	2-1048
CIPUCMMRead	2-1051
CIPUCMMWrite	2-1056
CIPUCMMSend	2-1063
SkUDPCreate	2-1073
SkUDPRcv	2-1081
SkUDPSend	2-1084
SkTCPAccept	2-1087
SkTCPConnect	2-1090
SkTCPRcv	2-1099
SkTCPSend	2-1102
SkGetTCPStatus	2-1105
SkClose	2-1108
SkClearBuf	2-1111
SkSetOption	2-1114
ChangeIPAdr	2-1119
ChangeFTPAccount	2-1127
ChangeNTPServerAdr	2-1131
FTPGetFileList	2-1135
FTPGetFile	2-1152
FTPPutFile	2-1161
FTPRemoveFile	2-1172
FTPRemoveDir	2-1182
Serial Communications Instructions	2-1187
ExecPMCR	2-1188
SerialSend	2-1201
SerialRcv and SerialRcvNoClear	2-1212
SendCmd	2-1227
NX_SerialSend	2-1240
NX_SerialRcv	2-1253
NX_ModbusRtuCmd	2-1267
NX_ModbusRtuRead	2-1277
NX_ModbusRtuWrite	2-1288
NX_SerialSigCtl	2-1299
NX_SerialSigRead	2-1308
NX_SerialStatusRead	2-1313
NX_SerialBufClear	2-1318
NX_SerialStartMon	2-1328
NX_SerialStopMon	2-1333
SD Memory Card Instructions	2-1337
FileWriteVar	2-1338
FileReadVar	2-1343
FileOpen	2-1348
FileClose	2-1352
FileSeek	2-1355
FileRead	2-1359
FileWrite	2-1367
FileGets	2-1375
FilePuts	2-1383
FileCopy	2-1392
FileRemove	2-1401
FileRename	2-1406

DirCreate	2-1411
DirRemove	2-1414
BackupToMemoryCard	2-1417
Time Stamp Instructions	2-1433
NX_DOutTimeStamp	2-1434
NX_AryDOutTimeStamp	2-1440
Other Instructions	2-1449
ReadNbit_**	2-1450
WriteNbit_**	2-1452
ChkRange	2-1454
GetMyTaskStatus	2-1456
GetMyTaskInterval	2-1459
Task_IsActive	2-1462
Lock and Unlock	2-1464
ActEventTask	2-1471
Get**Clk	2-1477
Get**Cnt	2-1478

Appendices

A-1 Error Codes That You Can Check with ErrorID	A-2
A-2 Error Code Descriptions	A-21
A-3 Error Code Details	A-55
A-4 Instructions You Cannot Use in Event Tasks	A-212
A-5 Instructions Related to NX Message Communications Errors	A-214
A-6 SDO Abort Codes	A-215
A-7 Version Information	A-216

Index

Terms and Conditions Agreement

Warranty, Limitations of Liability

Warranties

● Exclusive Warranty

Omron's exclusive warranty is that the Products will be free from defects in materials and workmanship for a period of twelve months from the date of sale by Omron (or such other period expressed in writing by Omron). Omron disclaims all other warranties, express or implied.

● Limitations

OMRON MAKES NO WARRANTY OR REPRESENTATION, EXPRESS OR IMPLIED, ABOUT NON-INFRINGEMENT, MERCHANTABILITY OR FITNESS FOR A PARTICULAR PURPOSE OF THE PRODUCTS. BUYER ACKNOWLEDGES THAT IT ALONE HAS DETERMINED THAT THE PRODUCTS WILL SUITABLY MEET THE REQUIREMENTS OF THEIR INTENDED USE.

Omron further disclaims all warranties and responsibility of any type for claims or expenses based on infringement by the Products or otherwise of any intellectual property right.

● Buyer Remedy

Omron's sole obligation hereunder shall be, at Omron's election, to (i) replace (in the form originally shipped with Buyer responsible for labor charges for removal or replacement thereof) the non-complying Product, (ii) repair the non-complying Product, or (iii) repay or credit Buyer an amount equal to the purchase price of the non-complying Product; provided that in no event shall Omron be responsible for warranty, repair, indemnity or any other claims or expenses regarding the Products unless Omron's analysis confirms that the Products were properly handled, stored, installed and maintained and not subject to contamination, abuse, misuse or inappropriate modification. Return of any Products by Buyer must be approved in writing by Omron before shipment. Omron Companies shall not be liable for the suitability or unsuitability or the results from the use of Products in combination with any electrical or electronic components, circuits, system assemblies or any other materials or substances or environments. Any advice, recommendations or information given orally or in writing, are not to be construed as an amendment or addition to the above warranty.

See <http://www.omron.com/global/> or contact your Omron representative for published information.

Limitation on Liability; Etc

OMRON COMPANIES SHALL NOT BE LIABLE FOR SPECIAL, INDIRECT, INCIDENTAL, OR CONSEQUENTIAL DAMAGES, LOSS OF PROFITS OR PRODUCTION OR COMMERCIAL LOSS IN ANY WAY CONNECTED WITH THE PRODUCTS, WHETHER SUCH CLAIM IS BASED IN CONTRACT, WARRANTY, NEGLIGENCE OR STRICT LIABILITY.

Further, in no event shall liability of Omron Companies exceed the individual price of the Product on which liability is asserted.

Application Considerations

Suitability of Use

Omron Companies shall not be responsible for conformity with any standards, codes or regulations which apply to the combination of the Product in the Buyer's application or use of the Product. At Buyer's request, Omron will provide applicable third party certification documents identifying ratings and limitations of use which apply to the Product. This information by itself is not sufficient for a complete determination of the suitability of the Product in combination with the end product, machine, system, or other application or use. Buyer shall be solely responsible for determining appropriateness of the particular Product with respect to Buyer's application, product or system. Buyer shall take application responsibility in all cases.

NEVER USE THE PRODUCT FOR AN APPLICATION INVOLVING SERIOUS RISK TO LIFE OR PROPERTY WITHOUT ENSURING THAT THE SYSTEM AS A WHOLE HAS BEEN DESIGNED TO ADDRESS THE RISKS, AND THAT THE OMRON PRODUCT(S) IS PROPERLY RATED AND INSTALLED FOR THE INTENDED USE WITHIN THE OVERALL EQUIPMENT OR SYSTEM.

Programmable Products

Omron Companies shall not be responsible for the user's programming of a programmable Product, or any consequence thereof.

Disclaimers

Performance Data

Data presented in Omron Company websites, catalogs and other materials is provided as a guide for the user in determining suitability and does not constitute a warranty. It may represent the result of Omron's test conditions, and the user must correlate it to actual application requirements. Actual performance is subject to the Omron's Warranty and Limitations of Liability.

Change in Specifications

Product specifications and accessories may be changed at any time based on improvements and other reasons. It is our practice to change part numbers when published ratings or features are changed, or when significant construction changes are made. However, some specifications of the Product may be changed without any notice. When in doubt, special part numbers may be assigned to fix or establish key specifications for your application. Please consult with your Omron's representative at any time to confirm actual specifications of purchased Product.

Errors and Omissions

Information presented by Omron Companies has been checked and is believed to be accurate; however, no responsibility is assumed for clerical, typographical or proofreading errors or omissions.

Safety Precautions

Refer to the following manuals for safety precautions.

- NX-series CPU Unit Hardware User's Manual (Cat. No. W535)
- NX-series NX1P2 CPU Unit Hardware User's Manual (Cat. No. W578)
- NJ-series CPU Unit Hardware User's Manual (Cat No. W500)

Precautions for Safe Use

Refer to the following manuals for precautions for safe use.

- NX-series CPU Unit Hardware User's Manual (Cat. No. W535)
- NX-series NX1P2 CPU Unit Hardware User's Manual (Cat. No. W578)
- NJ-series CPU Unit Hardware User's Manual (Cat No. W500)

Precautions for Correct Use

Refer to the following manuals for precautions for correct use.

- NX-series CPU Unit Hardware User's Manual (Cat. No. W535)
- NX-series NX1P2 CPU Unit Hardware User's Manual (Cat. No. W578)
- NJ-series CPU Unit Hardware User's Manual (Cat No. W500)

Regulations and Standards

Conformance to EU Directives

Applicable Directives

- EMC Directives
- Low Voltage Directive

Concepts

● EMC Directive

OMRON devices that comply with EU Directives also conform to the related EMC standards so that they can be more easily built into other devices or the overall machine. The actual products have been checked for conformity to EMC standards.*

Whether the products conform to the standards in the system used by the customer, however, must be checked by the customer. EMC-related performance of the OMRON devices that comply with EU Directives will vary depending on the configuration, wiring, and other conditions of the equipment or control panel on which the OMRON devices are installed. The customer must, therefore, perform the final check to confirm that devices and the overall machine conform to EMC standards.

* Applicable EMC (Electromagnetic Compatibility) standards are as follows:

EMS (Electromagnetic Susceptibility): EN 61131-2

EMI (Electromagnetic Interference): EN 61131-2 (Radiated emission: 10-m regulations)

● Low Voltage Directive

Always ensure that devices operating at voltages of 50 to 1,000 VAC and 75 to 1,500 VDC meet the required safety standards. The applicable directive is EN61010-2-201.

● Conformance to EU Directives

The NJ/NX-series Controllers comply with EU Directives. To ensure that the machine or device in which the NJ/NX-series Controller is used complies with EU Directives, the Controller must be installed as follows:

- The NJ/NX-series Controller must be installed within a control panel.
- You must use the power supply in SELV specifications for the DC power supplies connected to DC Power Supply Units and I/O Units.
- NJ/NX-series Controllers that comply with EU Directives also conform to the Common Emission Standard (EN 61000-6-4). Radiated emission characteristics (10-m regulations) may vary depending on the configuration of the control panel used, other devices connected to the control panel, wiring, and other conditions.

You must therefore confirm that the overall machine or equipment complies with EU Directives.

Conformance to KC Standards

Observe the following precaution if you use NX-series Units in Korea.

A 급 기기 (업무용방송통신기자재)
이 기기는 업무용(A 급) 전자파작합기기로서 판매자
또는 사용자는 이 점을 주의하시기 바라며, 가정외의
지역에서 사용하는 것을 목적으로 합니다.

Class A Device (Broadcasting Communications Device for Office Use)

This device obtained EMC registration for office use (Class A), and it is intended to be used in places other than homes.

Sellers and/or users need to take note of this.

Conformance to Shipbuilding Standards

The NJ/NX-series Controllers comply with the following shipbuilding standards. Applicability to the shipbuilding standards is based on certain usage conditions. It may not be possible to use the product in some locations. Contact your OMRON representative before attempting to use a Controller on a ship.

Usage Conditions for NK and LR Shipbuilding Standards

- The NJ/NX-series Controller must be installed within a control panel.
- Gaps in the door to the control panel must be completely filled or covered with gaskets or other material.
- The following noise filter must be connected to the power supply line.

Noise Filter

Manufacturer	Model
Cosel Co., Ltd.	TAH-06-683

Software Licenses and Copyrights

This product incorporates certain third party software. The license and copyright information associated with this software is available at http://www.fa.omron.co.jp/nj_info_e/.

Versions

Hardware revisions and unit versions are used to manage the hardware and software in NJ/NX-series Units and EtherCAT slaves. The hardware revision or unit version is updated each time there is a change in hardware or software specifications. Even when two Units or EtherCAT slaves have the same model number, they will have functional or performance differences if they have different hardware revision or unit versions.

Checking Versions

You can check versions in the ID information indications or with the Sysmac Studio.

Checking Unit Versions on ID Information Indications

The unit version is given on the ID information indication on the side of the product.

The ID information on an NX-series NX701-□□□□ CPU Unit is shown below.

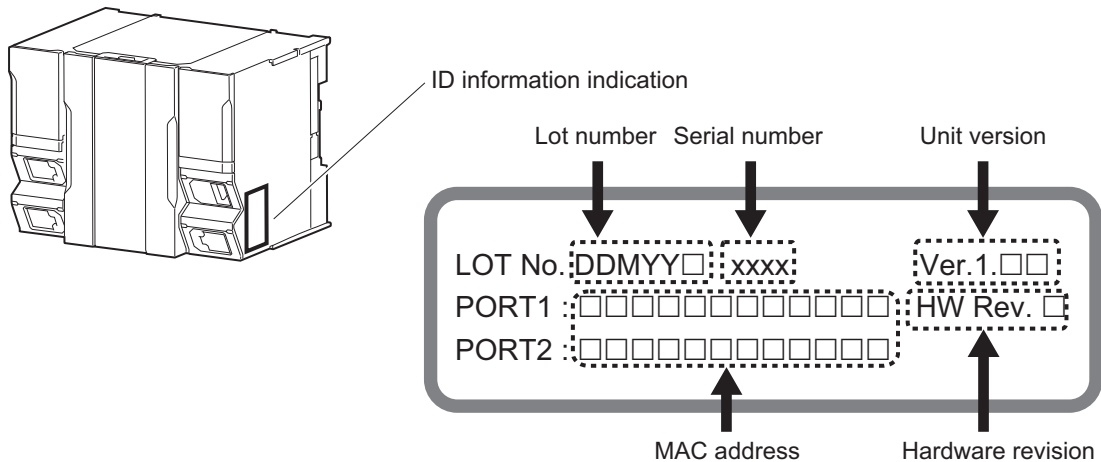

Note The hardware revision is not displayed for the Unit that the hardware revision is in blank.

The ID information on an NX-series NX1P2-□□□□□□□□ CPU Unit is shown below.

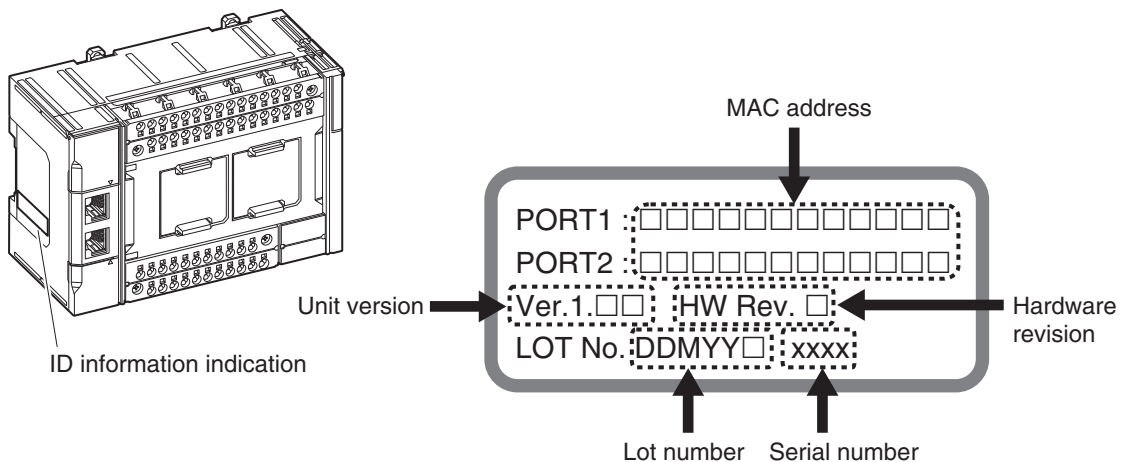

Note The hardware revision is not displayed for the Unit that the hardware revision is in blank.

The ID information on the NJ-series NJ501-□□□□ CPU Unit is shown below.

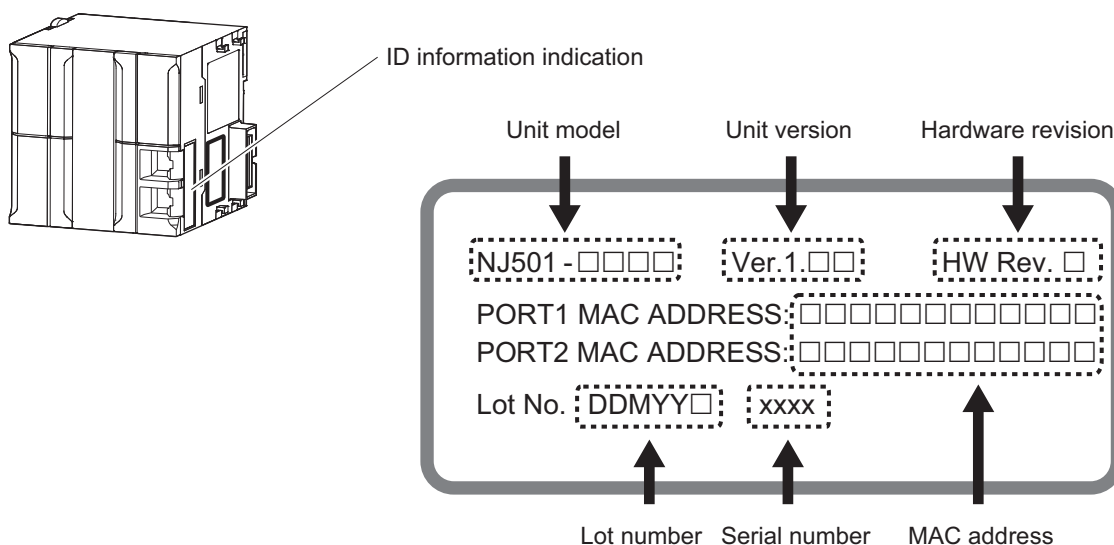

Note The hardware revision is not displayed for the Unit that the hardware revision is in blank.

Checking Unit Versions with the Sysmac Studio

You can use the Sysmac Studio to check unit versions. The procedure is different for Units and for EtherCAT slaves.

● Checking the Unit Version of an NX-series CPU Unit

You can use the Production Information while the Sysmac Studio is online to check the unit version of a Unit. You can do this for the CPU Unit. For an NX1P2 CPU Unit, you can also check the unit versions of the NX Units on the CPU Rack and Option Boards.

- 1 Right-click **CPU Rack** under **Configurations and Setup – CPU/Expansion Racks** in the Multiview Explorer and select **Production Information**.

The Production Information Dialog Box is displayed.

● Checking the Unit Version of an NJ-series CPU Unit

You can use the Production Information while the Sysmac Studio is online to check the unit version of a Unit. You can do this for the CPU Unit, CJ-series Special I/O Units, and CJ-series CPU Bus Units. You cannot check the unit versions of CJ-series Basic I/O Units with the Sysmac Studio.

Use the following procedure to check the unit version.

- 1 Double-click **CPU/Expansion Racks** under **Configurations and Setup** in the Multiview Explorer. Or, right-click **CPU/Expansion Racks** under **Configurations and Setup** and select **Edit** from the menu.

The Unit Editor is displayed.

- 2 Right-click any open space in the Unit Editor and select **Production Information**.

The Production Information Dialog Box is displayed.

● **Changing Information Displayed in Production Information Dialog Box**

- 1 Click the **Show Detail** or **Show Outline** Button at the lower right of the Production Information Dialog Box.

The view will change between the production information details and outline.

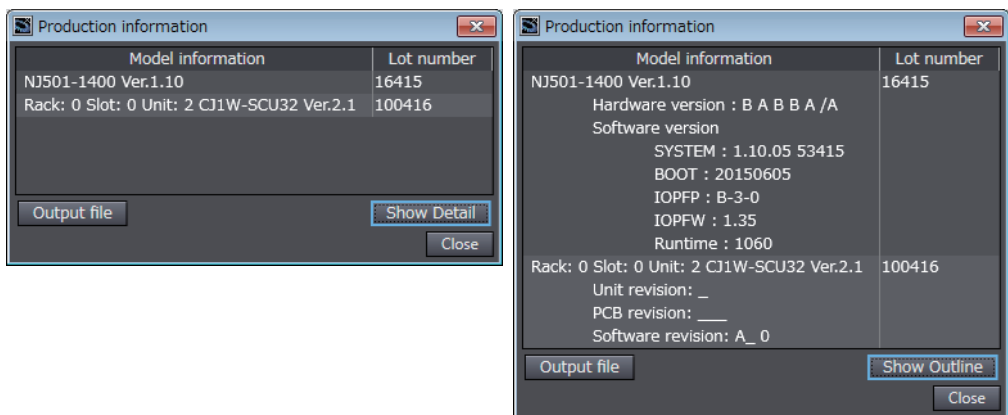

Outline View

Detail View

The information that is displayed is different for the Outline View and Detail View. The Detail View displays the unit version, hardware version, and software versions. The Outline View displays only the unit version.

Note The hardware revision is separated by "/" and displayed on the right of the hardware version. The hardware revision is not displayed for the Unit that the hardware revision is in blank.

● **Checking the Unit Version of an EtherCAT Slave**

You can use the Production Information while the Sysmac Studio is online to check the unit version of an EtherCAT slave. Use the following procedure to check the unit version.

- 1 Double-click **EtherCAT** under **Configurations and Setup** in the Multiview Explorer. Or, right-click **EtherCAT** under **Configurations and Setup** and select **Edit** from the menu.

The EtherCAT Tab Page is displayed.

- 2 Right-click the master on the EtherCAT Tab Page and select **Display Production Information**.

The Production Information Dialog Box is displayed.

The unit version is displayed after "Rev."

● **Changing Information Displayed in Production Information Dialog Box**

- 1 Click the **Show Detail** or **Show Outline** Button at the lower right of the Production Information Dialog Box.

The view will change between the production information details and outline.

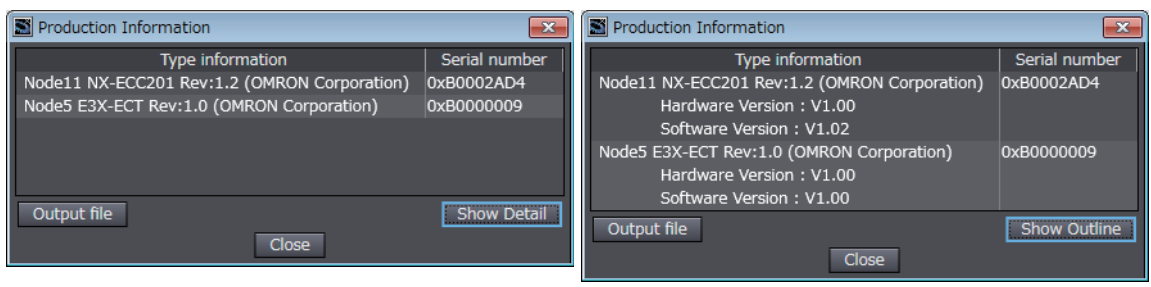

Outline View

Detail View

Unit Versions of CPU Units and Sysmac Studio Versions

The functions that are supported depend on the unit version of the NJ/NX-series CPU Unit. The version of Sysmac Studio that supports the functions that were added for an upgrade is also required to use those functions.

Refer to the *NJ/NX-series CPU Unit Software User's Manual* (Cat. No. W501) for the relationship between the unit versions of the CPU Units and the Sysmac Studio versions, and for the functions that are supported by each unit version.

Related Manuals

The followings are the manuals related to this manual. Use these manuals for reference.

Manual name	Cat. No.	Model numbers	Application	Description
NX-series CPU Unit Hardware User's Manual	W535	NX701-□□□□	Learning the basic specifications of the NX701 CPU Units, including introductory information, designing, installation, and maintenance. Mainly hardware information is provided.	An introduction to the entire NX701 system is provided along with the following information on the CPU Unit. <ul style="list-style-type: none"> • Features and system configuration • Introduction • Part names and functions • General specifications • Installation and wiring • Maintenance and inspection
NX-series NX1P2 CPU Unit Hardware User's Manual	W578	NX1P2-□□□□	Learning the basic specifications of the NX1P2 CPU Units, including introductory information, designing, installation, and maintenance. Mainly hardware information is provided.	An introduction to the entire NX1P2 system is provided along with the following information on the CPU Unit. <ul style="list-style-type: none"> • Features and system configuration • Introduction • Part names and functions • General specifications • Installation and wiring • Maintenance and inspection
NJ-series CPU Unit Hardware User's Manual	W500	NJ501-□□□□ NJ301-□□□□ NJ101-□□□□	Learning the basic specifications of the NJ-series CPU Units, including introductory information, designing, installation, and maintenance. Mainly hardware information is provided.	An introduction to the entire NJ-series system is provided along with the following information on the CPU Unit. <ul style="list-style-type: none"> • Features and system configuration • Introduction • Part names and functions • General specifications • Installation and wiring • Maintenance and inspection
NJ/NX-series CPU Unit Software User's Manual	W501	NX701-□□□□ NX1P2-□□□□ NJ501-□□□□ NJ301-□□□□ NJ101-□□□□	Learning how to program and set up an NJ/NX-series CPU Unit. Mainly software information is provided.	The following information is provided on an NJ/NX-series CPU Unit. <ul style="list-style-type: none"> • CPU Unit operation • CPU Unit features • Initial settings • Programming based on IEC 61131-3 language specifications
NX-series NX1P2 CPU Unit Built-in I/O and Option Board User's Manual	W579	NX1P2-□□□□	Learning about the details of functions only for an NX-series NX1P2 CPU Unit and an introduction of functions for an NJ/NX-series CPU Unit.	Of the functions for an NX1P2 CPU Unit, the following information is provided. <ul style="list-style-type: none"> • Built-in I/O • Serial Communications Option Boards • Analog I/O Option Boards An introduction of following functions for an NJ/NX-series CPU Unit is also provided. <ul style="list-style-type: none"> • Motion control functions • EtherNet/IP communications functions • EtherCAT communications functions
NJ/NX-series Instructions Reference Manual	W502	NX701-□□□□ NX1P2-□□□□ NJ501-□□□□ NJ301-□□□□ NJ101-□□□□	Learning detailed specifications on the basic instructions of an NJ/NX-series CPU Unit.	The instructions in the instruction set (IEC 61131-3 specifications) are described.
NJ/NX-series CPU Unit Motion Control User's Manual	W507	NX701-□□□□ NX1P2-□□□□ NJ501-□□□□ NJ301-□□□□ NJ101-□□□□	Learning about motion control settings and programming concepts.	The settings and operation of the CPU Unit and programming concepts for motion control are described.

Manual name	Cat. No.	Model numbers	Application	Description
NJ/NX-series Motion Control Instructions Reference Manual	W508	NX701-□□□□ NX1P2-□□□□ NJ501-□□□□ NJ301-□□□□ NJ101-□□□□	Learning about the specifications of the motion control instructions that are provided by OMRON.	The motion control instructions are described.
NJ/NX-series CPU Unit Built-in EtherCAT® Port User's Manual	W505	NX701-□□□□ NX1P2-□□□□ NJ501-□□□□ NJ301-□□□□ NJ101-□□□□	Using the built-in EtherCAT port on an NJ/NX-series CPU Unit.	Information on the built-in EtherCAT port is provided. This manual provides an introduction and provides information on the configuration, features, and setup.
NJ/NX-series CPU Unit Built-in EtherNet/IP™ Port User's Manual	W506	NX701-□□□□ NX1P2-□□□□ NJ501-□□□□ NJ301-□□□□ NJ101-□□□□	Using the built-in EtherNet/IP port on an NJ/NX-series CPU Unit.	Information on the built-in EtherNet/IP port is provided. Information is provided on the basic setup, tag data links, and other features.
NJ-series Database Connection CPU Units User's Manual	W527	NJ501-1□20 NJ101-□□20	Using the database connection service with NJ-series Controllers	Describes the database connection service.
NJ-series SECS/GEM CPU Unit User's Manual	W528	NJ501-1340	Using the GEM Services with NJ-series Controllers	Information is provided on the GEM Services.
NJ-series NJ Robotics CPU Unit User's Manual	W539	NJ501-4□□□	Controlling robots with NJ-series CPU Units.	Describes the functionality to control robots.
NJ/NY-series NC Integrated Controller User's Manual	O030	NJ501-5300 NY532-5400	Performing numerical control with NJ/NY-series Controllers.	Describes the functionality to perform the numerical control.
NJ/NY-series G code Instructions Reference Manual	O031	NJ501-5300 NY532-5400	Learning about the specifications of the G code/M code instructions.	The G code/M code instructions are described.
NJ/NX-series Troubleshooting Manual	W503	NX701-□□□□ NX1P2-□□□□ NJ501-□□□□ NJ301-□□□□ NJ101-□□□□	Learning about the errors that may be detected in an NJ/NX-series Controller.	Concepts on managing errors that may be detected in an NJ/NX-series Controller and information on individual errors are described.
Sysmac Studio Version 1 Operation Manual	W504	SYSMAC-SE2□□□	Learning about the operating procedures and functions of the Sysmac Studio.	Describes the operating procedures of the Sysmac Studio.
CNC Operator Operation Manual	O032	SYSMAC-RTNC0□□□D	Learning an introduction of the CNC Operator and how to use it.	An introduction of the CNC Operator, installation procedures, basic operations, connection operations, and operating procedures for main functions are described.
NX-series EtherCAT® Coupler Unit User's Manual	W519	NX-ECC□□□	Learning how to use an NX-series EtherCAT Coupler Unit and EtherCAT Slave Terminals	The system and configuration of EtherCAT Slave Terminals, which consist of an NX-series EtherCAT Coupler Unit and NX Units, are described along with the hardware, setup, and functions of the EtherCAT Coupler Unit that are required to configure, control, and monitor NX Units through EtherCAT.
NX-series Data Reference Manual	W525	NX-□□□□	Referencing lists of the data that is required to configure systems with NX-series Units.	Lists of the power consumptions, weights, and other NX Unit data that is required to configure systems with NX-series Units are provided.

Manual name	Cat. No.	Model numbers	Application	Description
NX-series NX Units User's Manuals	W521	NX-ID□□□□ NX-IA□□□□ NX-OC□□□□ NX-OD□□□□ NX-MD□□□□	Learning how to use NX Units	Describes the hardware, setup methods, and functions of the NX Units. Manuals are available for the following Units. Digital I/O Units, Analog I/O Units, System Units, Position Interface Units, Communications Interface Units, Load Cell Input Units, and IO-Link Master Units.
	W522	NX-AD□□□□ NX-DA□□□□		
	W566	NX-TS□□□□ NX-HB□□□□		
	W523	NX-PD1□□□ NX-PF0□□□ NX-PC0□□□ NX-TBX01		
	W524	NX-EC0□□□ NX-ECS□□□ NX-PG0□□□		
	W540	NX-CIF□□□		
	W565	NX-RS□□□□		
	W567	NX-ILM□□□		
CJ-series Special Unit Manuals for NJ-series CPU Unit	W490	CJ1W-AD□□□ CJ1W-DA□□□ CJ1W-MAD42	Learning how to use CJ- series Units with an NJ- series CPU Unit.	The methods and precautions for using CJ-series Units with an NJ501 CPU Unit are described, including access methods and programming interfaces. Manuals are available for the following Units. Analog I/O Units, Insulated-type Analog I/O Units, Temperature Control Units, ID Sensor Units, High-speed Counter Units, Serial Communications Units, DeviceNet Units, EtherNet/IP Units, and CompoNet Master Units.
	W491	CJ1W-TC□□□		
	W492	CJ1W-CT021		
	W498	CJ1W-PDC15 CJ1W-PH41U CJ1W-AD04U		
	W493	CJ1W-CRM21		
	W494	CJ1W-SCU□□		
	W495	CJ1W-EIP21		
	W497	CJ1W-DRM21		
Z317	CJ1W-V680□□□			
CX-Protocol Operation Manual	W344	—	Creating data transfer protocols for general-purpose devices connected to CJ-series Serial Communications Units.	Describes operating procedures for the CX-Protocol.

Revision History

A manual revision code appears as a suffix to the catalog number on the front and back covers of the manual.

Cat. No. W502-E1-21

↑
Revision code

Revision code	Date	Revised content
01	July 2011	Original production
02	September 2011	Corrected mistakes.
03	March 2012	Made changes accompanying release of unit version 1.01 of the CPU Unit and version 1.02 of the Sysmac Studio.
04	May 2012	Made changes accompanying release of unit version 1.02 of the CPU Unit and version 1.03 of the Sysmac Studio.
05	August 2012	Made changes accompanying release of unit version 1.03 of the CPU Unit and version 1.04 of the Sysmac Studio.
06	February 2013	Made changes accompanying release of unit version 1.04 of the CPU Unit and version 1.05 of the Sysmac Studio.
07	April 2013	Made changes accompanying release of unit version 1.05 of the CPU Unit and version 1.06 of the Sysmac Studio.
08	June 2013	Made changes accompanying release of unit version 1.06 of the CPU Unit and version 1.07 of the Sysmac Studio.
09	September 2013	Made changes accompanying release of unit version 1.07 of the CPU Unit and version 1.08 of the Sysmac Studio.
10	December 2013	Made changes accompanying release of unit version 1.08 of the CPU Unit and version 1.09 of the Sysmac Studio.
11	July 2014	Made changes accompanying release of unit version 1.09 of the CPU Unit and version 1.10 of the Sysmac Studio.
12	January 2015	Made changes accompanying release of unit version 1.10 of the CPU Unit and version 1.12 of the Sysmac Studio.
13	April 2015	<ul style="list-style-type: none"> • Made changes accompanying the addition of NX-series NX701-□□□□ CPU Units and the release of version 1.13 of the Sysmac Studio. • Added information on the NJ101-□□□□ NJ-series CPU Units. • Corrected mistakes.
14	October 2015	<ul style="list-style-type: none"> • Made changes accompanying the addition of hardware revision. • Corrected mistakes.
15	April 2016	Made changes accompanying release of unit version 1.11 of the CPU Unit and version 1.15 of the Sysmac Studio.
16	July 2016	<ul style="list-style-type: none"> • Made changes accompanying release of unit version 1.12 of the CPU Unit and version 1.16 of the Sysmac Studio. • Corrected mistakes.
17	October 2016	<ul style="list-style-type: none"> • Made changes accompanying release of unit version 1.13 of the CPU Unit and version 1.17 of the Sysmac Studio. • Corrected mistakes.
18	November 2016	Corrected mistakes.
19	January 2017	Corrected mistakes.
20	April 2017	Corrected mistakes.
21	October 2017	<ul style="list-style-type: none"> • Made changes accompanying release of unit version 1.16 of the CPU Unit and version 1.20 of the Sysmac Studio. • Corrected mistakes.

1

Instruction Set

This section provides a table of the instructions that you can use with NJ/NX-series Controllers.

Instruction Set	1-2
------------------------------	------------

Instruction Set

Type	Instruction	Name	Function	Page
Ladder Diagram Instructions	LD	Load	Reads the value of a BOOL variable.	2-16
	LDN	Load NOT	Reads the inverse of the value of a BOOL variable.	2-16
	AND	AND	Takes the logical AND of the value of a BOOL variable and the input value.	2-18
	ANDN	AND NOT	Takes the logical AND of the inverse of the value of a BOOL variable and the input value.	2-18
	OR	OR	Takes the logical OR of the value of a BOOL variable and the execution condition.	2-20
	ORN	OR NOT	Takes the logical OR of the inverse of the value of a BOOL variable and the execution condition.	2-20
	Out	Output	Takes the logical result from the previous instruction and outputs it to a BOOL variable.	2-22
	OutNot	Output NOT	Takes the inverse of the logical result from the previous instruction and outputs it to a BOOL variable.	2-22
ST Statement Instructions	IF	If	Uses the evaluation result of a specified condition expression to select one of two statements to execute.	2-26
	CASE	Case	Selects the statement to execute based on the value of a specified integer expression.	2-30
	WHILE	While	Repeatedly executes a statement as long as the evaluation result of a specified condition expression is TRUE.	2-34
	REPEAT	Repeat	Executes a statement once and then executes it repeatedly until a specified condition expression is TRUE.	2-36
	EXIT	Break Loop	Used to end repeat processing from the lowest level FOR, WHILE, or REPEAT instruction.	2-38
	RETURN	Return	Ends a function or function block and returns processing to the calling instruction.	2-41
	FOR	Repeat Start	Marks the starting position for repeat processing of statements between the FOR and END_FOR statements and specifies the repeat condition.	2-42
Sequence Input Instructions	R_TRIG (Up)	Up Trigger	Outputs TRUE for one task period only when the input signal changes to TRUE.	2-44
	F_TRIG (Down)	Down Trigger	Outputs TRUE for one task period only when the input signal changes to FALSE.	2-44
	TestABit	Test A Bit	Outputs the value of the specified bit in a bit string.	2-47
	TestABitN	Test A Bit NOT	Outputs the inverse of the value of the specified bit in a bit string.	2-47
Sequence Output Instructions	RS	Reset-Priority Keep	Retains the value of a BOOL variable. It gives priority to the <i>Reset</i> input if both the <i>Set</i> input and <i>Reset</i> input are TRUE.	2-50

Type	Instruction	Name	Function	Page
Sequence Output Instructions	SR	Set-Priority Keep	Retains the value of a BOOL variable. It gives priority to the <i>Set</i> input if both the <i>Set</i> input and <i>Reset</i> input are TRUE.	2-53
	Set	Set	Changes a BOOL variable to TRUE.	2-56
	Reset	Reset	Changes a BOOL variable to FALSE.	2-56
	SetBits	Set Bits	Changes consecutive bits in bit string data to TRUE.	2-59
	ResetBits	Reset Bits	Changes consecutive bits in bit string data to FALSE.	2-59
	SetABit	Set A Bit	Changes the specified bit in bit string data to TRUE.	2-61
	ResetABit	Reset A Bit	Changes the specified bit in bit string data to FALSE.	2-61
	OutABit	Output A Bit	Changes the specified bit in bit string data to TRUE or FALSE.	2-63
Sequence Control Instructions	End	End	Ends execution of a program in the current task period.	2-66
	RETURN	Return	Ends a function or function block and returns processing to the calling instruction.	2-67
	MC	Master Control Start	Marks the starting point of a master control region and resets the master control region.	2-68
	MCR	Master Control End	Marks the end point of a master control region.	2-68
	JMP	Jump	Moves processing to the specified jump destination.	2-80
	FOR	Repeat Start	Marks the starting position for repeat processing and specifies the repeat condition.	2-82
	NEXT	Repeat End	Marks the ending position for repeat processing.	2-82
	BREAK	Break Loop	Cancels repeat processing from the lowest level FOR instruction to the NEXT instruction.	2-89
Comparison Instructions	EQ (=)	Equal	Determines if two or more values or text strings are all equivalent.	2-92
	NE (<>)	Not Equal	Determines if two values or text strings are not equivalent.	2-94
	LT (<)	Less Than	Performs a less than comparison between values.	2-97
	LE (<=)	Less Than Or Equal	Performs a less than or equal comparison between values.	2-97
	GT (>)	Greater Than	Performs a greater than comparison between values.	2-97
	GE (>=)	Greater Than Or Equal	Performs a greater than or equal comparison between values.	2-97
	EQascii	Text String Comparison Equal	Determines if two or more text strings are all equivalent.	2-100
	NEascii	Text String Comparison Not Equal	Determines if two text strings are not equivalent.	2-102
	LTascii	Text String Comparison Less Than	Performs a less than comparison between text strings.	2-104
	LEascii	Text String Comparison Less Than or Equal	Performs a less than or equal comparison between text strings.	2-104

Type	Instruction	Name	Function	Page
Comparison Instructions	GTascii	Text String Comparison Greater Than	Performs a greater than comparison between text strings.	2-104
	GEascii	Text String Comparison Greater Than or Equal	Performs a greater than or equal comparison between text strings.	2-104
	Cmp	Compare	Compares two values.	2-107
	ZoneCmp	Zone Comparison	Determines if the comparison data is within the specified maximum and minimum values.	2-109
	TableCmp	Table Comparison	Compares the comparison data with multiple defined ranges in a comparison table.	2-111
	AryCmpEQ	Array Comparison Equal	Determines if the corresponding elements of two arrays are equal.	2-114
	AryCmpNE	Array Comparison Not Equal	Determines if the corresponding elements of two arrays are not equal.	2-114
	AryCmpLT	Array Comparison Less Than	Performs a less than comparison between the corresponding elements of two arrays.	2-116
	AryCmpLE	Array Comparison Less Than Or Equal	Performs a less than or equal comparison between the corresponding elements of two arrays.	2-116
	AryCmpGT	Array Comparison Greater Than	Performs a greater than comparison between the corresponding elements of two arrays.	2-116
	AryCmpGE	Array Comparison Greater Than Or Equal	Performs a greater than or equal comparison between the corresponding elements of two arrays.	2-116
	AryCmpEQV	Array Value Comparison Equal	Determines if the elements of an array are equal to a value.	2-119
	AryCmpNEV	Array Value Comparison Not Equal	Determines if the elements of an array are not equal to a value.	2-119
	AryCmpLTV	Array Value Comparison Less Than	Performs a less than comparison between a value and the elements of an array.	2-121
	AryCmpLEV	Array Value Comparison Less Than Or Equal	Performs a less than or equal comparison between a value and the elements of an array.	2-121
	AryCmpGTV	Array Value Comparison Greater Than	Performs a greater than comparison between a value and the elements of an array.	2-121
	AryCmpGEV	Array Value Comparison Greater Than Or Equal	Performs a greater than or equal comparison between a value and the elements of an array.	2-121
Timer Instructions	TON	On-Delay Timer	Outputs TRUE when the set time elapses after the timer starts.	2-126
	TOF	Off-Delay Timer	Outputs FALSE when the set time elapses after the timer starts.	2-132
	TP	Timer Pulse	Outputs TRUE while the set time elapses after the timer starts.	2-135
	AccumulationTimer	Accumulation Timer	Totals the time that the timer input is TRUE.	2-138
	Timer	Hundred-ms Timer	Outputs TRUE when the set time elapses after the timer starts. The time is set in increments of 100 ms.	2-141

Type	Instruction	Name	Function	Page
Counter Instructions	CTD	Down-counter	Decrements the counter value when the counter input signal is received. The preset value and counter value must have an INT data type.	2-146
	CTD_**	Down-counter Group	Decrements the counter value when the counter input signal is received. The preset value and counter value must be one of the following data types: DINT, LINT, UDINT, or ULINT.	2-148
	CTU	Up-counter	Increments the counter value when the counter input signal is received. The preset value and counter value must have an INT data type.	2-150
	CTU_**	Up-counter Group	Increments the counter value when the counter input signal is received. The preset value and counter value must be one of the following data types: DINT, LINT, UDINT, or ULINT.	2-152
	CTUD	Up-down Counter	Creates an up-down counter that operates according to an up-counter input and a down-counter input. The preset value and counter value must have an INT data type.	2-155
	CTUD_**	Up-down Counter Group	Creates an up-down counter that operates according to an up-counter input and a down-counter input. The preset value and counter value must be one of the following data types: DINT, LINT, UDINT, or ULINT.	2-159
Math Instructions	ADD (+)	Addition	Adds integers and real numbers. Also joins text strings.	2-166
	AddOU (+OU)	Addition with Overflow Check	Adds integers and real numbers. Also performs an overflow check for the integer addition result.	2-170
	SUB (-)	Subtraction	Subtracts integers and real numbers.	2-174
	SubOU (-OU)	Subtraction with Overflow Check	Subtracts integers or real numbers. Also performs an overflow check for the integer subtraction result.	2-177
	MUL (*)	Multiplication	Multiplies integers and real numbers.	2-181
	MulOU (*OU)	Multiplication with Overflow Check	Multiplies integers and real numbers and outputs the result. Also performs an overflow check for the integer multiplication result.	2-185
	DIV (/)	Division	Divides integers or real numbers.	2-189
	MOD	Modulo-division	Finds the remainder for division of integers.	2-192
	ABS	Absolute Value	Finds the absolute value of an integer or real number.	2-194
	RadToDeg	Radians to Degrees	Converts a real number from radians (rad) to degrees (°).	2-196
	DegToRad	Degrees to Radians	Converts a real number from degrees (°) to radians (rad).	2-196
	SIN	Sine in Radians	Calculates the sine of a real number.	2-198
	COS	Cosine in Radians	Calculates the cosine of a real number.	2-198
	TAN	Tangent in Radians	Calculates the tangent of a real number.	2-198
	ASIN	Principal Arc Sine	Calculates the arcsine of a real number.	2-201
	ACOS	Principal Arc Cosine	Calculates the arccosine of a real number.	2-201
ATAN	Principal Arc Tangent	Calculates the arctangent of a real number.	2-201	

Type	Instruction	Name	Function	Page
Math Instructions	SQRT	Square Root	Finds the square root of a number.	2-204
	LN	Natural Logarithm	Finds the natural logarithm of a real number.	2-206
	LOG	Logarithm Base 10	Finds the base-10 logarithm of a real number.	2-206
	EXP	Natural Exponential Operation	Performs calculations for the natural exponential function.	2-209
	EXPT (**)	Exponentiation	Raises one real number to the power of another real number.	2-211
	Inc	Increment	Increments an integer value.	2-217
	Dec	Decrement	Decrements an integer value.	2-217
	Rand	Random Number	Generates pseudorandom numbers.	2-219
	AryAdd	Array Addition	Adds corresponding elements of two arrays.	2-221
	AryAddV	Array Value Addition	Adds the same value to specified elements of an array.	2-223
	ArySub	Array Subtraction	Subtracts corresponding elements of two arrays.	2-225
	ArySubV	Array Value Subtraction	Subtracts the same value from specified elements of an array.	2-227
	AryMean	Array Mean	Calculates the average of the elements of an array.	2-229
	ArySD	Array Element Standard Deviation	Calculates standard deviation of the elements of an array.	2-231
	BCD Conversion Instructions	**_BCD_TO_***	BCD-to-Uncoded Integer Conversion Group	Converts BCD bit strings into unsigned integers.
_TO_BCD_*		Unsigned Integer-to-BCD Conversion Group	Converts unsigned integers to BCD bit strings.	2-245
BCD_TO_**		BCD Data Type-to-Uncoded Integer Conversion Group	Converts BCD bit strings into unsigned integers.	2-247
BCDsToBin		Signed BCD-to-Signed Integer Conversion	Converts signed BCD bit strings to signed integers.	2-250
BinToBCDs_**		Signed Integer-to-BCD Conversion Group	Converts signed integers to signed BCD bit strings.	2-253
AryToBCD		Array BCD Conversion	Converts the elements of an unsigned integer array to BCD bit strings.	2-256
AryToBin		Array Unsigned Integer Conversion	Converts the elements of an array of BCD bit strings into unsigned integers.	2-258
Data Type Conversion Instructions		**_TO_*** (Integer-to-Integer Conversion Group)	Integer-to-Integer Conversion Group	Converts integers to integers with different data types.
	TO* (Integer-to-Bit String Conversion Group)	Integer-to-Bit String Conversion Group	Converts integers to bit strings.	2-265

Type	Instruction	Name	Function	Page
Data Type Conversion Instructions	**_TO_*** (Integer-to-Real Number Conversion Group)	Integer-to-Real Number Conversion Group	Converts integers to real numbers.	2-268
	TO* (Bit String-to-Integer Conversion Group)	Bit String-to-Integer Conversion Group	Converts bit strings to integers.	2-270
	TO* (Bit String-to-Bit String Conversion Group)	Bit String-to-Bit String Conversion Group	Converts bit strings to bit strings with different data types.	2-272
	TO* (Bit String-to-Real Number Conversion Group)	Bit String-to-Real Number Conversion Group	Converts bit strings to real numbers.	2-274
	TO* (Real Number-to-Integer Conversion Group)	Real Number-to-Integer Conversion Group	Converts real numbers to integers.	2-276
	TO* (Real Number-to-Bit String Conversion Group)	Real Number-to-Bit String Conversion Group	Converts real numbers to bit strings.	2-279
	TO* (Real Number-to-Real Number Conversion Group)	Real Number-to-Real Number Conversion Group	Converts real numbers to real numbers with different data types.	2-281
	**_TO_STRING (Integer-to-Text String Conversion Group)	Integer-to-Text String Conversion Group	Converts integers to text strings.	2-283
	**_TO_STRING (Bit String-to-Text String Conversion Group)	Bit String-to-Text String Conversion Group	Converts bit strings to text strings.	2-285
	**_TO_STRING (Real Number-to-Text String Conversion Group)	Real Number-to-Text String Conversion Group	Converts real numbers to text strings.	2-287
	RealToFormatString	REAL-to-Formatted Text String	Converts a REAL variable to a text string with the specified format.	2-289
	LrealToFormatString	LREAL-to-Formatted Text String	Converts a LREAL variable to a text string with the specified format.	2-294
	STRING_TO_** (Text String-to-Integer Conversion Group)	Text String-to-Integer Conversion Group	Converts text strings to integers.	2-299
	STRING_TO_** (Text String-to-Bit String Conversion Group)	Text String-to-Bit String Conversion Group	Converts text strings to bit strings.	2-301
	STRING_TO_** (Text String-to-Real Number Conversion Group)	Text String-to-Real Number Conversion Group	Converts text strings to real numbers.	2-303
	TO_** (Integer Conversion Group)	Integer Conversion Group	Converts integers, bit strings, real numbers, and text strings to integers.	2-306
	TO_** (Bit String Conversion Group)	Bit String Conversion Group	Converts integers, bit strings, real numbers, and text strings to bit strings.	2-308
	TO_** (Real Number Conversion Group)	Real Number Conversion Group	Converts integers, bit strings, real numbers, and text strings to real numbers.	2-310
	EnumToNum	Enumeration-to-Integer	The EnumToNum instruction converts enumeration data to DINT data.	2-312
	NumToEnum	Integer-to-Enumeration	The NumToEnum instruction converts DINT data to enumeration data.	2-314

Type	Instruction	Name	Function	Page
Data Type Conversion Instructions	TRUNC	Truncate	Truncates a real number at the first decimal digit to make an integer.	2-316
	Round	Round Off Real Number	Rounds a real number at the first decimal digit to make an integer.	2-316
	RoundUp	Round Up Real Number	Rounds up a real number at the first decimal digit to make an integer.	2-316
Bit String Processing Instructions	AND (&)	Logical AND	Performs a logical AND operation on Boolean variables or individual bits in bit stings.	2-320
	OR	Logical OR	Performs a logical OR operation on Boolean variables or individual bits in bit stings.	2-320
	XOR	Logical Exclusive OR	Performs a logical exclusive OR operation on Boolean variables or individual bits in bit stings.	2-320
	XORN	Logical Exclusive NOR	Performs a logical exclusive NOR operation on Boolean variables or individual bits in bit stings.	2-323
	NOT	Bit Reversal	Reverses the value of a Boolean variable or individual bits in a bit string.	2-325
	AryAnd	Array Logical AND	Performs a logical AND operation on Boolean variables or individual bits in bit stings between arrays.	2-327
	AryOr	Array Logical OR	Performs a logical OR operation on Boolean variables or individual bits in bit stings between arrays.	2-327
	AryXor	Array Logical Exclusive OR	Performs a logical exclusive OR operation on Boolean variables or individual bits in bit stings between arrays.	2-327
	AryXorN	Array Logical Exclusive NOR	Performs a logical exclusive NOR operation on Boolean variables or individual bits in bit stings between arrays.	2-327
Selection Instructions	SEL	Binary Selection	Selects one of two selections.	2-332
	MUX	Multiplexer	Selects one of two to five selections.	2-334
	LIMIT	Limiter	Limits the value of the input variable to the specified minimum and maximum values.	2-337
	Band	Deadband Control	Performs deadband control.	2-339
	Zone	Dead Zone Control	Adds a bias value to the input value.	2-342
	MAX	Maximum	Finds the largest of two to five values.	2-345
	MIN	Minimum	Finds the smallest of two to five values.	2-345
	AryMax	Array Maximum	Finds the elements with the largest value in a one-dimensional array.	2-347
	AryMin	Array Minimum	Finds the elements with the smallest value in a one-dimensional array.	2-347
	ArySearch	Array Search	Searches for the specified value in a one-dimensional array.	2-350
Data Movement Instructions	MOVE	Move	Moves the value of a constant or variable to another variable.	2-354
	MoveBit	Move Bit	Moves one bit in a bit string.	2-357
	MoveDigit	Move Digit	Moves digits (4 bits per digit) in a bit string.	2-359
	TransBits	Move Bits	Moves one or more bits in a bit string.	2-361
	MemCopy	Memory Copy	Moves one or more array elements. The move source and move destination must have the same data type.	2-363

Type	Instruction	Name	Function	Page
Data Movement Instructions	SetBlock	Block Set	Moves the value of a variable or constant to one or more array elements.	2-365
	Exchange	Data Exchange	Exchanges the values of two variables.	2-367
	AryExchange	Array Data Exchange	Exchanges the elements of two arrays.	2-369
	AryMove	Array Move	Moves one or more array elements. The data types of the move source and move destination can be different.	2-371
	Clear	Initialize	Initializes a variable.	2-373
	Copy**ToNum (Bit String to Signed Integer)	Bit Pattern Copy (Bit String to Signed Integer) Group	Copies the content of a bit string directly to a signed integer.	2-375
	Copy**To*** (Bit String to Real Number)	Bit Pattern Copy (Bit String to Real Number) Group	Copies the content of a bit string directly to a real number.	2-377
	CopyNumTo** (Signed Integer to Bit String)	Bit Pattern Copy (Signed Integer to Bit String) Group	Copies the content of a signed integer directly to a bit string.	2-379
	CopyNumTo** (Signed Integer to Real Number)	Bit Pattern Copy (Signed Integer to Real Number) Group	Copies the content of a signed integer directly to a real number.	2-381
	Copy**To*** (Real Number to Bit String)	Bit Pattern Copy (Real Number to Bit String) Group	Copies the content of a real number directly to a bit string.	2-383
Copy**ToNum (Real Number to Signed Integer)	Bit Pattern Copy (Real Number to Signed Integer) Group	Copies the content of a real number directly to a signed integer.	2-385	
Shift Instructions	AryShiftReg	Shift Register	Shifts a bit string one bit to the left and inserts the input value to the least-significant bit. The bit string consists of array elements.	2-388
	AryShiftRegLR	Reversible Shift Register	Shifts a bit string one bit to the left or right and inserts the input value to the least-significant or most-significant bit. The bit string consists of array elements.	2-390
	ArySHL	Array N-element Left Shift	Shifts array elements by one or more elements to the left (toward the higher elements).	2-393
	ArySHR	Array N-element Right Shift	Shifts array elements by one or more elements to the right (toward the lower elements).	2-393
	SHL	N-bit Left Shift	Shifts a bit string by one or more bits to the left (toward the higher bits).	2-396
	SHR	N-bit Right Shift	Shifts a bit string by one or more bits to the right (toward the lower bits).	2-396
	NSHLC	Shift N-bits Left with Carry	Shifts an array of bit strings that includes the Carry (CY) Flag by one or more bits to the left (toward the higher elements).	2-398
	NSHRC	Shift N-bits Right with Carry	Shifts an array of bit strings that includes the Carry (CY) Flag by one or more bits to the right (toward the lower elements).	2-398
	ROL	Rotate N-bits Left	Rotates a bit string by one or more bits to the left (toward the higher bits).	2-400
	ROR	Rotate N-bits Right	Rotates a bit string by one or more bits to the right (toward the lower bits).	2-400

Type	Instruction	Name	Function	Page
Conversion Instructions	Swap	Swap Bytes	Swaps the upper byte and lower byte of a 16-bit value.	2-404
	Neg	Reverse Sign	Reverses the sign of a number.	2-405
	Decoder	Bit Decoder	Sets the specified bit to TRUE and the other bits to FALSE in array elements that consist of a maximum of 256 bits.	2-407
	Encoder	Bit Encoder	Finds the position of the highest TRUE bit in array elements that consist of a maximum of 256 bits.	2-410
	BitCnt	Bit Counter	Counts the number of TRUE bits in a bit string.	2-412
	ColmToLine_**	Column to Line Conversion Group	Extracts bit values from the specified position of array elements and outputs them as a bit string.	2-413
	LineToColm	Line to Column Conversion	Takes the bits from a bit string and outputs them to the specified bit position in array elements.	2-415
	Gray	Gray Code Conversion	Converts a gray code into an angle.	2-417
	UTF8ToSJIS	UTF-8 to SJIS Character Code Conversion	Converts a UTF-8 text string to a SJIS BYTE array.	2-422
	SJISToUTF8	SJIS to UTF-8 Character Code Conversion	Converts a SJIS BYTE array to a UTF-8 text string.	2-424
	PWLApprox	Broken Line Approximation with Broken Line Data Check	Performs broken line approximations for integers or real numbers along with a check of the validity of the broken line data.	2-426
	PWLApproxNoLineChk	Broken Line Approximation without Broken Line Data Check	Performs broken line approximations for integers or real numbers along without a check of the validity of the broken line data.	2-426
	PWLLineChk	Broken Line Data Check	Checks whether the X coordinates in the broken line data that is used for a Broken Line Approximation without Broken Line Data Check instruction are in ascending order.	2-432
	MovingAverage	Moving Average	Calculates a moving average.	2-435
	DispartReal	Separate Mantissa and Exponent	Separates a real number into the signed mantissa and the exponent.	2-441
	UniteReal	Combine Real Number Mantissa and Exponent	Combines a signed mantissa and exponent to make a real number.	2-444
	NumToDecString	Fixed-length Decimal Text String Conversion	Converts an integer to a fixed-length decimal text string.	2-446
NumToHexString	Fixed-length Hexadecimal Text String Conversion	Converts an integer to a fixed-length hexadecimal text string.	2-446	
HexStringToNum_**	Hexadecimal Text String-to-Number Conversion Group	Converts a hexadecimal text string to an integer.	2-449	
FixNumToString	Fixed-decimal Number-to-Text String Conversion	Converts a signed fixed-decimal number to a decimal text string.	2-451	

Type	Instruction	Name	Function	Page
Conversion Instructions	StringToFixNum	Text String-to-Fixed-decimal Conversion	Converts a decimal text string to a signed fixed-decimal number.	2-453
	DtToString	Date and Time-to-Text String Conversion	Converts a date and time to a text string.	2-456
	DateToString	Date-to-Text String Conversion	Converts a date to a text string.	2-458
	TodToString	Time of Day-to-Text String Conversion	Converts a time of day to a text string.	2-459
	GrayToBin_**	Gray Code-to-Binary Code Conversion Group	Converts a gray code to a bit string.	2-461
	BinToGray_**	Binary Code-to-Gray Code Conversion	Converts a bit string to a gray code.	2-461
	StringToAry	Text String-to-Array Conversion	Converts a text string to a BYTE array.	2-463
	AryToString	Array-to-Text String Conversion	Converts a BYTE array to a text string.	2-465
	DispartDigit	Four-bit Separation	Separates a bit string into 4-bit units.	2-467
	UniteDigit_**	Four-bit Join Group	Joins 4-bit units of data into a bit string.	2-469
	Dispart8Bit	Byte Data Separation	Separates a bit string into individual bytes.	2-471
	Unite8Bit_**	Byte Data Join Group	Joins bytes of data into a bit string.	2-473
	ToAryByte	Conversion to Byte Array	Separates the value of a variable into bytes and stores them in a BYTE array.	2-475
	AryByteTo	Conversion from Byte Array	Joins BYTE array elements and stores the result in a variable.	2-480
	SizeOfAry	Get Number of Array Elements	Gets the number of elements in an array.	2-485
	PackWord	2-byte Join	Joins two 1-byte data into a 2-byte data.	2-487
PackDword	4-byte Join	Joins four 1-byte data into a 4-byte data.	2-489	

Type	Instruction	Name	Function	Page
Stack and Table Instructions	StackPush	Push onto Stack	Stores a value in a stack.	2-492
	StackFIFO	First In First Out	Removes the bottom value from a stack.	2-501
	StackLIFO	Last In First Out	Removes the top value from a stack.	2-501
	StackIns	Insert into Stack	Inserts a value at a specified position in a stack.	2-504
	StackDel	Delete from Stack	Deletes a value from a specified position in a stack.	2-506
	RecSearch	Record Search	Searches an array of structures for elements that match the search key with the specified method.	2-508
	RecRangeSearch	Range Record Search	Searches an array of structures for elements that match the search condition range with the specified method.	2-513
	RecSort	Record Sort	Sorts the elements of an array of structures.	2-518
	RecNum	Get Number of Records	Finds the number of records in an array of structures to the end data.	2-524
	RecMax	Maximum Record Search	Searches the specified member in the structures of an array of structures for the maximum value.	2-526
	RecMin	Minimum Record Search	Searches the specified member in the structures of an array of structures for the minimum value.	2-526
FCS Instructions	StringSum	Checksum Calculation	Calculates the checksum for a text string.	2-532
	StringLRC	Calculate Text String LRC	Calculates the LRC value (horizontal parity).	2-534
	StringCRCCCITT	Calculate Text String CRC-CCITT	Calculates the CRC-CCITT value using the XMODEM method.	2-536
	StringCRC16	Calculate Text String CRC-16	Calculates the CRC-16 value using the MOD-BUS method.	2-538
	AryLRC_**	Calculate Array LRC Group	Calculates the LRC value for an array	2-540
	AryCRCCCITT	Calculate Array CRC-CCITT	Calculates the CRC-CCITT value using the XMODEM method.	2-542
	AryCRC16	Calculate Array CRC-16	Calculates the CRC-16 value using the MOD-BUS method.	2-544

Type	Instruction	Name	Function	Page
Text String Instructions	CONCAT	Concatenate String	Joins two to five text strings.	2-548
	LEFT	Get String Left	Extracts a text string with the specified number of characters from the start (left) of a text string.	2-550
	RIGHT	Get String Right	Extracts a text string with the specified number of characters from the end (right) of a text string.	2-550
	MID	Get String Any	Extracts a text string with the specified number of characters from the specified character position.	2-552
	FIND	Find String	Searches a specified text string for the position of a specified text string.	2-554
	LEN	String Length	Finds the number of characters in a text string.	2-556
	REPLACE	Replace String	Replaces part of a text string with another text string	2-557
	DELETE	Delete String	Deletes all or part of a text string.	2-559
	INSERT	Insert String	Inserts a text string into another text string.	2-561
	GetByteLen	Get Byte Length	Counts the number of bytes in a text string.	2-563
	ClearString	Clear String	Clears a text string.	2-565
	ToUCase	Convert to Uppercase	Converts all single-byte letters in a text string to uppercase.	2-567
	ToLCase	Convert to Lowercase	Converts all single-byte letters in a text string to lowercase.	2-567
	TrimL	Trim String Left	Removes blank space from the beginning of a text string.	2-569
	TrimR	Trim String Right	Removes blank space from the end of a text string.	2-569
AddDelimiter	Put Text Strings with Delimiters	Converts the values in a structure to text strings and adds delimiters.	2-571	
SubDelimiter	Get Text Strings Minus Delimiters	Reads delimited data from a text string and stores the results as the values of the members of a structure.	2-582	

Type	Instruction	Name	Function	Page
Time and Time of Day Instructions	ADD_TIME	Add Time	Adds two times.	2-594
	ADD_TOD_TIME	Add Time to Time of Day	Adds a time to a time of day.	2-596
	ADD_DT_TIME	Add Time to Date and Time	Adds a time to a date and time.	2-598
	SUB_TIME	Subtract Time	Subtracts one time from another.	2-600
	SUB_TOD_TIME	Subtract Time from Time of Day	Subtracts a time from a time of day.	2-602
	SUB_TOD_TOD	Subtract Time of Day	Subtracts a time of day from another time of day.	2-604
	SUB_DATE_DATE	Subtract Date	Subtracts another date from another date.	2-605
	SUB_DT_DT	Subtract Date and Time	Subtracts another date and time from another date and time.	2-606
	SUB_DT_TIME	Subtract Time from Date and Time	Subtracts a time from a date and time.	2-608
	MULTIME	Multiply Time	Multiplies a time by a specified number.	2-610
	DIVTIME	Divide Time	Divides a time by a specified number.	2-612
	CONCAT_DATE_TOD	Concatenate Date and Time of Day	Combines a date and a time of day.	2-614
	DT_TO_TOD	Extract Time of Day from Date and Time	Extracts the time of day from a date and time.	2-616
	DT_TO_DATE	Extract Date from Date and Time	Extracts the date from a date and time.	2-618
	SetTime	Set Time	Sets the system time.	2-620
	GetTime	Get Time of Day	Reads the current time.	2-622
	DtToSec	Convert Date and Time to Seconds	Converts a date and time to the number of seconds from 00:00:00 on January 1, 1970.	2-624
	DateToSec	Convert Date to Seconds	Converts a date to the number of seconds from 00:00:00 on January 1, 1970.	2-626
	TodToSec	Convert Time of Day to Seconds	Converts a time of day to the number of seconds from 00:00:00.	2-627
	SecToDt	Convert Seconds to Date and Time	Converts the number of seconds from 00:00:00 on January 1, 1970 to a date and time.	2-628
	SecToDate	Convert Seconds to Date	Converts the number of seconds from 00:00:00 on January 1, 1970 to a date.	2-630
	SecToTod	Convert Seconds to Time of Day	Converts the number of seconds from 00:00:00 to a time of day.	2-632
	TimeToNanoSec	Convert Time to Nanoseconds	Converts a time to nanoseconds.	2-634
	TimeToSec	Convert Time to Seconds	Converts a time to seconds.	2-635
	NanoSecToTime	Convert Nanoseconds to Time	Converts nanoseconds to a time.	2-636
	SecToTime	Convert Seconds to Time	Converts seconds to a time.	2-637
	ChkLeapYear	Check for Leap Year	Checks for a leap year.	2-639
GetDaysOfMonth	Get Days in Month	Gets the number of days in the specified month.	2-640	

Type	Instruction	Name	Function	Page
Time and Time of Day Instructions	DaysToMonth	Convert Days to Month	Calculates the month based on the number of days from January 1.	2-642
	GetDayOfWeek	Get Day of Week	Gets the day of the week for the specified year, month, and day of month.	2-644
	GetWeekOfYear	Get Week Number	Gets the week number for the specified year, month, and day of month.	2-646
	DtToDateStruct	Break Down Date and Time	Converts a date and time to the year, month, day, hour, minutes, seconds, and nanoseconds.	2-648
	DateStructToDt	Join Time	Joins a year, month, day, hour, minutes, seconds, and nanoseconds into a date and time.	2-650
	TruncTime	Truncate Time	Truncates a TIME variable below the specified time unit.	2-652
	TruncDt	Truncate Date and Time	Truncates a DT variable below the specified time unit.	2-656
	TruncTod	Truncate Time of Day	Truncates a TOD variable below the specified time unit.	2-660
Analog Control Instructions	PIDAT	PID Control with Autotuning	Performs PID control with autotuning (2-PID control with set point filter).	2-666
	PIDAT_HeatCool	Heating/Cooling PID with Autotuning	Performs heating/cooling PID control with autotuning (2-PID control with set point filter).	2-691
	TimeProportionalOut	Time-proportional Output	Converts a manipulated variable to a time-proportional output.	2-729
	LimitAlarm_**	Upper/Lower Limit Alarm Group	Outputs an alarm if the input value is below the lower limit set value or above the upper limit set value.	2-745
	LimitAlarmDv_**	Upper/Lower Deviation Alarm Group	Outputs an alarm if the deviation in the input value from the reference value exceeds the lower deviation set value or the upper deviation set value.	2-749
	LimitAlarmDvStbySeq_**	Upper/Lower Deviation Alarm with Standby Sequence Group	Outputs upper and lower deviation alarms with a standby sequence.	2-754
	ScaleTrans	Scale Transformation	Converts input values from an input range to an output range.	2-769
	AC_StepProgram	Step Program	Calculates the present set point and the predicted set point every task period according to the specified program pattern.	2-772
System Control Instructions	TraceSamp	Data Trace Sampling	Performs sampling for a data trace.	2-798
	TraceTrig	Data Trace Trigger	Generates a trigger for data tracing.	2-801
	GetTraceStatus	Read Data Trace Status	Reads the execution status of a data trace.	2-804
	SetAlarm	Create User-defined Error	Creates a user-defined error.	2-808
	ResetAlarm	Reset User-defined Error	Resets a user-defined error.	2-813
	GetAlarm	Get User-defined Error Status	Gets the highest event level (of user-defined error levels 1 to 8) and the highest level event code of the current user-defined errors.	2-815
	ResetPLCError	Reset PLC Controller Error	Resets errors in the PLC Function Module.	2-817

Type	Instruction	Name	Function	Page
System Control Instructions	GetPLCError	Get PLC Controller Error Status	Gets the highest level status (partial fault or minor fault) and highest level event code of the current Controller errors in the PLC Function Module.	2-820
	ResetCJBError	Reset CJ Bus Controller Error	Resets a Controller Error in the I/O bus.	2-822
	GetCJBError	Get I/O Bus Error Status	Gets the highest level status and highest level event code of the current Controller errors in the I/O bus of the NJ-series CPU Unit.	2-824
	GetEIPErr	Get EtherNet/IP Error Status	Gets the highest level status (partial fault or minor fault) and highest level event code of the current Controller errors in the EtherNet/IP Function Module.	2-826
	ResetMCErr	Reset Motion Control Error	Resets a Controller Error in the Motion Control Function Module.	2-828
	GetMCErr	Get Motion Control Error Status	Gets the highest level status (partial fault or minor fault) and highest level event code of the current Controller errors in the Motion Control Function Module.	2-833
	ResetECErr	Reset EtherCAT Error	Resets a Controller Error in the EtherCAT Master Function Module.	2-835
	GetECErr	Get EtherCAT Error Status	Detects errors in the EtherCAT Master Function Module.	2-837
	ResetNXBErr	Reset NX Bus Error	Resets the current Controller errors in the NX Bus Function Module.	2-840
	GetNXBErr	Get NX Bus Error Status	Gets the highest level status of all current Controller errors in the NX Bus Function Module of the NX-series CPU Unit.	2-842
	GetNXUnitErr	Get NX Unit Error Status	Gets the highest level status and highest level event code of the current Controller errors in the NX Bus Function Module of the NX-series CPU Unit or NX Units.	2-844
	SetInfo	Create User-defined Information	Creates user-defined information.	2-852
	ResetUnit	Restart Unit	Restarts a CPU Bus Unit or Special I/O Unit.	2-854
	GetNTPStatus	Read NTP Status	Reads the NTP status.	2-858
	RestartNXUnit	Restart NX Unit	Restarts an EtherCAT Coupler Unit or NX Unit.	2-860
	NX_ChangeWriteMode	Change to NX Unit Write Mode	Changes an EtherCAT Coupler Unit or NX Unit to a mode that allows writing data.	2-866
	NX_SaveParam	Save NX Unit Parameters	Saves the data that was written to an EtherCAT Coupler Unit or NX Unit.	2-871
	NX_ReadTotalPowerOnTime	Read NX Unit Total Power ON Time	Reads the total power ON time from a Communications Coupler Unit or NX Unit.	2-877
PLC_ReadTotalPowerOnTime	Read PLC Total Power ON Time	Reads the total power ON time from a specified CPU Unit.	2-885	
Program Control Instructions	PrgStart	Enable Program	Enables the execution of the specified program.	2-890
	PrgStop	Disable Program	Disables execution of the specified program.	2-899
	PrgStatus	Read Program Status	Reads the status of the specified program.	2-919

Type	Instruction	Name	Function	Page
EtherCAT Communications Instructions	EC_CoESDOWrite	Write EtherCAT CoE SDO	Writes a value to a CoE object of a specified slave on the EtherCAT network.	2-926
	EC_CoESDORead	Read EtherCAT CoE SDO	Reads a value from a CoE object of a specified slave on the EtherCAT network.	2-929
	EC_StartMon	Start EtherCAT Packet Monitor	Starts packet monitoring for EtherCAT communications.	2-934
	EC_StopMon	Stop EtherCAT Packet Monitor	Stops execution of packet monitoring for EtherCAT communications.	2-940
	EC_SaveMon	Save EtherCAT Packets	Saves EtherCAT communications packet data to an internal file in the main memory of the CPU Unit.	2-942
	EC_CopyMon	Transfer EtherCAT Packets	Transfers packet data in an internal file in the main memory of the CPU Unit to a SD Memory Card.	2-944
	EC_DisconnectSlave	Disconnect EtherCAT Slave	Disconnects the specified slave from the EtherCAT network.	2-946
	EC_ConnectSlave	Connect EtherCAT Slave	Connects the specified slave to the EtherCAT network.	2-953
	EC_ChangeEnableSetting	Enable/Disable EtherCAT Slave	Enables or disables an EtherCAT slave.	2-955
	NX_WriteObj	Write NX Unit Object	Writes data to an NX object in an EtherCAT Coupler Unit or NX Unit.	2-972
	NX_ReadObj	Read NX Unit Object	Reads data from an NX object in an EtherCAT Coupler Unit or NX Unit.	2-987
IO-Link Communications Instruction	IOL_ReadObj	Read IO-Link Device Object	Reads data from IO-Link device objects.	2-998
	IOL_WriteObj	Write IO-Link Device Object	Writes data to IO-Link device objects.	2-1007
EtherNet/IP Communications Instructions	CIPOpen	Open CIP Class 3 Connection (Large_Forward_Open)	Opens a CIP class 3 connection (Large_Forward_Open) with the specified remote node. The data length is set to 1,994 bytes.	2-1018
	CIPOpenWithDataSize	Open CIP Class 3 Connection with Specified Data Size	Opens a CIP class 3 connection with the specified remote node that allows class 3 explicit messages of the specified data length or shorter to be sent and received.	2-1027
	CIPRead	Read Variable Class 3 Explicit	Uses a class 3 explicit message to read the value of a variable in another Controller on a CIP network.	2-1031
	CIPWrite	Write Variable Class 3 Explicit	Uses a class 3 explicit message to write the value of a variable in another Controller on a CIP network.	2-1037
	CIPSend	Send Explicit Message Class 3	Sends a class 3 CIP message to a specified device on a CIP network.	2-1043
	CIPClose	Close CIP Class 3 Connection	Closes the CIP class 3 connection to the specified handle.	2-1048
	CIPUCMMRead	Read Variable UCMM Explicit	Uses a UCMM explicit message to read the value of a variable in another Controller on the specified CIP network.	2-1051
	CIPUCMMWrite	Write Variable UCMM Explicit	Uses a UCMM explicit message to write the value of a variable in another Controller on a CIP network.	2-1056
	CIPUCMMSend	Send Explicit Message UCMM	Sends a UCMM CIP message to a specified device on a CIP network.	2-1063

Type	Instruction	Name	Function	Page
EtherNet/IP Communica- tions Instruc- tions	SktUDPCreate	Create UDP Socket	Creates a UDP socket request to open a servo port for the built-in EtherNet/IP.	2-1073
	SktUDPRcv	UDP Socket Receive	Reads the data from the receive buffer for a UDP socket for the built-in EtherNet/IP.	2-1081
	SktUDPSend	UDP Socket Send	Sends data from a UDP port for the built-in EtherNet/IP.	2-1084
	SktTCPAccept	Accept TCP Socket	Requests accepting a TCP socket for the built- in EtherNet/IP.	2-1087
	SktTCPConnect	Connect TCP Socket	Connects to a remote TCP port from the built- in EtherNet/IP.	2-1090
	SktTCPRcv	TCP Socket Receive	Reads the data from the receive buffer for a TCP socket for the built-in EtherNet/IP.	2-1099
	SktTCPSend	TCP Socket Send	Sends data from a TCP port for the built-in Eth- erNet/IP.	2-1102
	SktGetTCPStatus	Read TCP Socket Status	Reads the status of a TCP socket.	2-1105
	SktClose	Close TCP/UDP Socket	Closes the specified TCP or UDP socket for the built-in EtherNet/IP.	2-1108
	SktClearBuf	Clear TCP/UDP Socket Receive Buffer	Clears the receive buffer for the specified TCP or UDP socket for the built-in EtherNet/IP.	2-1111
	SktSetOption	Set TCP Socket Option	Sets the option for TCP socket specified for the built-in EtherNet/IP.	2-1114
	ChangeIPAdr	Change IP Address	Changes the IP address of the built-in Ether- Net/IP port or the IP address of an EtherNet/IP Unit.	2-1119
	ChangeFTPAccount	Change FTP Account	Changes the FTP login name and password of the built-in EtherNet/IP port or those of an Eth- erNet/IP Unit.	2-1127
	ChangeNTPServerAdr	Change NTP Server Address	Changes the address of the NTP server of the built-in EtherNet/IP port or the address of an EtherNet/IP Unit.	2-1131
	FTPGetFileList	Get FTP Server File List	Gets a list of the files in the FTP server.	2-1135
	FTPGetFile	Get File from FTP Server	Downloads a file from the FTP server.	2-1152
	FTPPutFile	Put File onto FTP Server	Uploads a file to the FTP server.	2-1161
	FTPRemoveFile	Delete FTP Server File	Deletes a file from the FTP server.	2-1172
FTPRemoveDir	Delete FTP Server Directory	Deletes a directory from the FTP server.	2-1182	

Type	Instruction	Name	Function	Page
Serial Communications Instructions	ExecPMCR	Protocol Macro	Requests execution of a communications sequence (protocol data) registered in a Serial Communications Unit.	2-1188
	SerialSend	SCU Send Serial	Sends data in No-protocol Mode from a serial port on a Serial Communications Unit.	2-1201
	SerialRcv	SCU Receive Serial	Receives data in No-protocol Mode from a serial port on a Serial Communications Unit. It then clears the receive buffer after reading the data.	2-1212
	SerialRcvNoClear	SCU Receive Serial without Receive Buffer Clear	Receives data in No-protocol Mode from a serial port on a Serial Communications Unit. It does not clear the receive buffer after reading the data.	2-1212
	SendCmd	Send Command	Uses a serial gateway and sends a command to a Serial Communications Unit. Or, sends an explicit command to a DeviceNet Unit or CompoNet Master Unit.	2-1227
	NX_SerialSend	Send No-protocol Data	Sends data in No-protocol Mode from a serial port on an NX-series Communications Interface Unit or Option Board.	2-1240
	NX_SerialRcv	Receive No-protocol Data	Reads data in No-protocol Mode from a serial port on an NX-series Communications Interface Unit or Option Board.	2-1253
	NX_ModbusRtuCmd	Send Modbus RTU General Command	Sends general commands from a serial port on an NX-series Communications Interface Unit or Option Board to Modbus-RTU slaves using Modbus-RTU protocol.	2-1267
	NX_ModbusRtuRead	Send Modbus RTU Read Command	Sends read commands from a serial port on an NX-series Communications Interface Unit or Option Board to Modbus-RTU slaves using Modbus-RTU protocol.	2-1277
	NX_ModbusRtuWrite	Send Modbus RTU Write Command	Sends write commands from a serial port on an NX-series Communications Interface Unit or Option Board to Modbus-RTU slaves using Modbus-RTU protocol.	2-1288
	NX_SerialSigCtl	Serial Control Signal ON/OFF Switching	Turns ON or OFF the ER or RS signal of a serial port on an NX-series Communications Interface Unit or Option Board.	2-1299
	NX_SerialSigRead	Read Serial Control Signal	Reads the CS or DR signal of a serial port on an Option Board.	2-1308
	NX_SerialStatusRead	Read Serial Port Status	Reads the status of a serial port on an Option Board.	2-1313
	NX_SerialBufClear	Clear Buffer	Clears the send or receive buffer.	2-1318
	NX_SerialStartMon	Start Serial Line Monitoring	Starts serial line monitoring of an NX-series Communications Interface Unit.	2-1328
NX_SerialStopMon	Stop Serial Line Monitoring	Stops serial line monitoring of an NX-series Communications Interface Unit.	2-1333	

Type	Instruction	Name	Function	Page
SD Memory Card Instructions	FileWriteVar	Write Variable to File	Writes the value of a variable to the specified file in the SD Memory Card. The value is written in binary format.	2-1338
	FileReadVar	Read Variable from File	Reads the contents of the specified file on the SD Memory Card as binary data and writes it to a variable.	2-1343
	FileOpen	Open File	Opens the specified file in the SD Memory Card.	2-1348
	FileClose	Close File	Closes the specified file in the SD Memory Card.	2-1352
	FileSeek	Seek File	Sets a file position indicator in the specified file in the SD Memory Card.	2-1355
	FileRead	Read File	Reads the data from the specified file in the SD Memory Card.	2-1359
	FileWrite	Write File	Writes data to the specified file in the SD Memory Card.	2-1367
	FileGets	Get Text String	Reads a text string of one line from the specified file in the SD Memory Card.	2-1375
	FilePuts	Put Text String	Writes a text string to the specified file in the SD Memory Card.	2-1383
	FileCopy	Copy File	Copies the specified file in the SD Memory Card.	2-1392
	FileRemove	Delete File	Deletes the specified file from the SD Memory Card.	2-1401
	FileRename	Change File Name	Changes the name of the specified file or directory in the SD Memory Card.	2-1406
	DirCreate	Create Directory	Creates a directory with the specified name in the SD Memory Card.	2-1411
	DirRemove	Delete Directory	Deletes the specified directory from the SD Memory Card.	2-1414
BackupToMemoryCard	SD Memory Card Backup	Backs up data to an SD Memory Card.	2-1417	
Time Stamp Instructions	NX_DOutTimeStamp	Write Digital Output with Specified Time Stamp	Writes a value to the output bit of a Digital Output Unit that supports time stamp refreshing.	2-1434
	NX_AryDOutTimeStamp	Write Digital Output Array with Specified Time Stamp	Outputs pulses from a Digital Output Unit that supports time stamp refreshing.	2-1440

Type	Instruction	Name	Function	Page
Other Instructions	ReadNbit_**	N-bit Read Group	Reads zero or more bits from a bit string.	2-1450
	WriteNbit_**	N-bit Write Group	Writes zero or more bits to a bit string.	2-1452
	ChkRange	Check Subrange Variable	Determines if the value of a variable is within the valid range of the range type specification.	2-1454
	GetMyTaskStatus	Read Current Task Status	Reads the status of the current task.	2-1456
	GetMyTaskInterval	Read Current Task Period	Reads the task period of the current task.	2-1459
	Task_IsActive	Determine Task Status	Determines if the specified task is currently in execution.	2-1462
	Lock	Lock Tasks	Starts an exclusive lock between tasks. Execution of any other task with a lock region with the same lock number is disabled.	2-1464
	Unlock	Unlock Tasks	Stops an exclusive lock between tasks.	2-1464
	ActEventTask	Activate Event Task	Activates an event task.	2-1471
	Get**Clk	Get Clock Pulse Group	Outputs a clock pulse at the specified cycle.	2-1477
	Get**Cnt	Get Incrementing Free-running Counter Group	Gets the values of free-running counters of the specified cycle.	2-1478

- Refer to the *NJ/NX-series Motion Control Instructions Reference Manual* (Cat. No. W508) for the specifications of the motion control instructions.
- Refer to the *Sysmac Studio Version 1 Operation Manual* (Cat. No. W504) for the specifications of the simulation instructions.

2

Instruction Descriptions

This section describes the specifications of the instructions that you can use with NJ/NX-series Controllers.

Using this Section	2-3
Ladder Diagram Instructions	2-15
ST Statement Instructions	2-25
Sequence Input Instructions	2-43
Sequence Output Instructions	2-49
Sequence Control Instructions	2-65
Comparison Instructions	2-91
Timer Instructions	2-125
Counter Instructions	2-145
Math Instructions	2-165
BCD Conversion Instructions	2-241
Data Type Conversion Instructions	2-261
Bit String Processing Instructions	2-319
Selection Instructions	2-331
Data Movement Instructions	2-353
Shift Instructions	2-387
Conversion Instructions	2-403
Stack and Table Instructions	2-491
FCS Instructions	2-531
Text String Instructions	2-547
Time and Time of Day Instructions	2-593
Analog Control Instructions	2-665
System Control Instructions	2-797
Program Control Instructions	2-889
EtherCAT Communications Instructions	2-925
IO-Link Communications Instruction	2-997

EtherNet/IP Communications Instructions2-1017
Serial Communications Instructions2-1187
SD Memory Card Instructions2-1337
Time Stamp Instructions2-1433
Other Instructions2-1449

Using this Section

The notation used to describe instructions in this section is explained below.

Items

The following items are provided.

Item	Description
Instruction	The instruction word is given. Example: MoveBit
Name	The name of the instruction is given. Example: Move Bit
FB/FUN	Whether the instruction is a function block (FB) instruction or a function (FUN) instruction is given. You can call FB instructions only from programs and function blocks. You can call FUN instructions from programs, function blocks, and functions.
Graphic expression	<p>The figure that represents the instruction in a ladder diagram is given.</p> <div style="display: flex; justify-content: space-around;"> <div style="text-align: center;"> <p>Example for a FUN Instruction</p> </div> <div style="text-align: center;"> <p>Example for a FB Instruction</p> </div> </div> <p>The instruction option, upward differentiation specification, and instance specification are described below.</p> <p>Instruction option: Support for the instruction option is indicated by “()” before the FUN instruction. If support for the instruction option is indicated, you can place “@” before the instruction word to specify upward differentiation. An instruction for which upward differentiation is specified is executed when the value of the EN input variable was FALSE in the previous task period and is TRUE in the current task period.</p> <p>Upward differentiation specification: This is indicated by the arrow pointing into the instruction at the entry point of the input variable. Instructions with this specification operate as upwardly differentiated instructions.</p> <p>Instance specification: An instance of an instruction is indicated by “XX_instance” above an FB instruction. You must assign an instance name to any instance of an instruction that you specify.</p>
ST expression	<p>The notation that represents the instruction in ST is given.</p> <p>There are two ways that you can use to code an instruction in ST. These are described below.</p> <ol style="list-style-type: none"> 1. Directly Specifying the Correspondence between the Parameters and the Input, Output, and In-Out Variables Example: MoveBit(In:=abc, InPos:=def, InOut:=ghi, InOutPos:=jkl); 2. Specifying Only the Parameters and Omitting the Input, Output, and In-Out Variables Example: MoveBit(In, InPos, InOut, InOutPos); <p>Method 2 is used in this section.</p> <p>You must assign an instance name to any instruction that is given as “XX_instance(variable_name).” Example: TON_instance (In, PT, Q, ET);</p>

Item	Description
Variables	<ul style="list-style-type: none"> • Name The input variables, output variables, and in-out variables are given. Example: <i>In1</i> However, variables that are used by many instructions are not given on the pages that describe individual instructions. The following eight variables are commonly used. The specifications of these variables are given later. (<i>EN</i>, <i>ENO</i>, <i>Execute</i>, <i>Done</i>, <i>Busy</i>, <i>Error</i>, <i>ErrorID</i>, and <i>ErrorIDEx</i>) • Meaning The name of the variable is given. Example: Up-counter • I/O Whether the variable is an input variable, output variable, or in-out variable is given. • Description The meaning of the variable and any restrictions are given. • Valid range The range that the variable can take is given. "Depends on data type" indicates that the valid range of the variable depends on the data type that you use. The valid ranges of the data types are given later in this section. • Unit The unit of the value that is specified with the variable is given. "---" indicates that there is no unit. Example: Bytes • Default The specified default value is automatically used for the variable if you do not assign a parameter to the instruction before it is executed. "---" indicates the following: <ul style="list-style-type: none"> Input variables: The default value of the data type of the input variable is assigned. The default values of the data types are given later in this section. If the input variable is a structure, the default value is given in the specifications of the structure in the description of the function of the instruction. Output variables: Default values are not set. In-out variables: Default values are not set. • Data type The data type of the variable is given. The use of enumerations, arrays, structures, and unions is also given.
Function	<p>The function of the instruction is described. Variable names are given in italic text. Example: <i>In1</i> Array names are followed by "[]". Example: <i>InOut[]</i></p>
Related System-defined Variables	<p>The system-defined variables that are related to the instruction are given. Refer to the <i>NJ/NX-series CPU Unit Software User's Manual</i> (Cat. No. W501) or <i>NY-series Industrial Panel PC / Industrial Box PC Software User's Manual</i> (Cat. No. W558) for details on system-defined variables.</p>
Related Semi-user-defined Variables	<p>The semi-user-defined variables and variable names that are related to the instruction are given. Refer to the specified manuals for details on semi-user-defined variables.</p>
Additional Information	<p>Additional information on the function of the instruction is provided. This includes related instructions and helpful information for application of the instruction.</p>
Precautions for Correct Use	<p>Precautions for application of the instruction are given. The conditions under which errors occur for the instruction are also given here.</p>
Sample Programming	<p>Short samples of how to use the instruction in an application program are provided. The ladder diagram and ST for the same process are shown.</p>

Common Variables

The specifications of variables that are used for many instructions (*EN*, *ENO*, *Execute*, *Done*, *Busy*, *Error*, *ErrorID*, and *ErrorIDEx*) are described below. These variables are not described in the tables of variables for individual instructions. Check the graphic or ST expression for the instruction to see if an instruction uses these variables.

EN

EN is an input variable that gives the execution condition for a FUN instruction.

When you use a FUN instruction in a ladder diagram, connect the execution condition to *EN*.

Name	Meaning	I/O	Description	Data type	Valid range	Default
EN	Enable (Execution Condition)	Input	TRUE: Instruction is executed.* FALSE: Instruction is not executed.	BOOL	TRUE or FALSE	TRUE

* If upward differentiation (@) is specified as an instruction option, the execution condition is when the value of *EN* changes from FALSE to TRUE. If downward differentiation (%) is specified as an instruction option, the execution condition is when the value of *EN* changes from TRUE to FALSE.

- FB instructions do not have an *EN* input variable.
- When you call a FUN instruction from structured text, omit the *EN* input variable. The *EN* input variable is not required in structured text because the execution condition for the instruction is determined by the operation sequence.

ENO

The *ENO* output variable passes the execution to the next instruction in a ladder diagram. Normally, when instruction execution is completed, the value of *ENO* changes to TRUE. Execution of the next instruction is then started.

Name	Meaning	I/O	Description	Data type	Valid range	Default
ENO	Enable Output	Output	TRUE: Normal end.* FALSE: Error end, execution in progress, or execution condition not met.	BOOL	TRUE or FALSE	---

* *ENO* is TRUE only while the execution condition is met. The value of *ENO* changes to FALSE when the execution condition is no longer met after a normal end.

- Most FUN instructions and FB instructions have *ENO* output variables. There are, however, some instructions that do not have an *ENO* output variable.
- Omit the *ENO* output variable in structured text. The *ENO* output variable is not required in structured text because the execution condition for the next instruction is determined by the operation sequence.

Execute, Done, and Busy

Execute is an input variable that gives the execution condition for some FB instructions.

Instruction execution starts when *Execute* changes to TRUE. After *Execute* changes to TRUE, execution of this instruction is continued until processing is completed even if the value of *Execute* changes to FALSE or the instruction execution time exceeds the task period.

Done is an output variable that shows the completion of execution for some FB instructions.

Busy is an output variable that shows that instruction execution is in progress for some FB instructions.

Name	Meaning	I/O	Description	Data type	Valid range	Initial value
Execute	Execute	Input	TRUE: Instruction is executed.*1 FALSE: Instruction is not executed.*2	BOOL	TRUE or FALSE	FALSE
Done	Done	Output	TRUE: Normal end.*3*4 FALSE: Error end, execution in progress, or execution condition not met.	BOOL	TRUE or FALSE	---
Busy	Busy		TRUE: Execution processing is in progress. FALSE: Execution processing is not in progress.			

*1 If the value of *Execute* is already TRUE when Controller operation starts, the instruction is not executed. To execute the instruction in that case, first change the value of *Execute* to FALSE.

*2 Processing is completed to the end even if *Execute* changes to FALSE during execution.

*3 The value of *Done* changes to FALSE when the execution condition is no longer met after a normal end.

*4 If the execution condition is no longer met when a normal end occurs, the value of *Done* is TRUE for one task period and it then changes to FALSE.

Timing charts are given below for instructions that have *EN* and *ENO* variables (i.e., instructions that are completed in one task period) and for instructions that have *Execute* and *Busy* variables (i.e., instructions that are processed over more than one task period).

● Instructions Completed in One Task Period

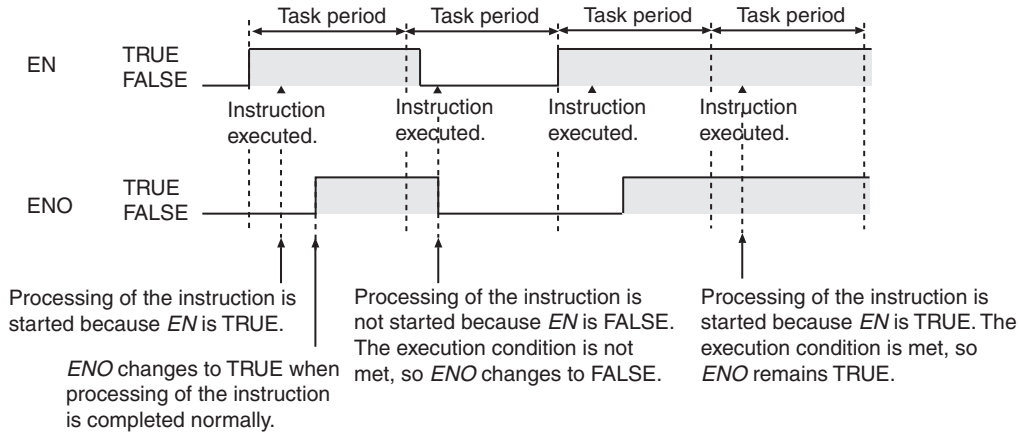

● Instructions Processed Over More Than One Task Period

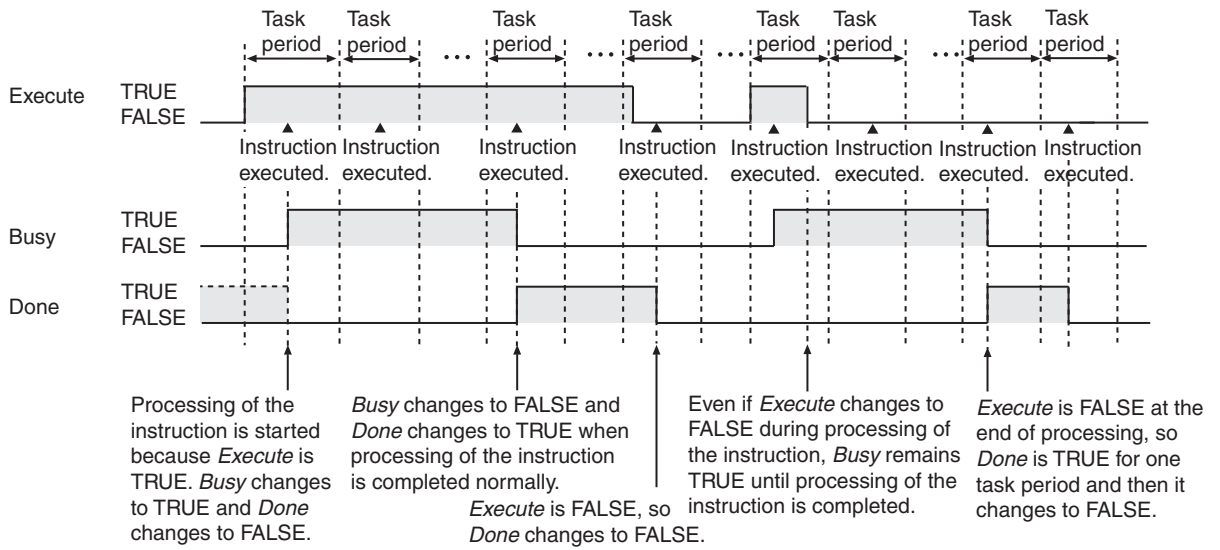

Using this Section

2

Common Variables

Error, ErrorID, and ErrorIDEx

Error, *ErrorID*, and *ErrorIDEx* are output variables that show that an error occurred in the execution of some FB instructions.

Name	Meaning	I/O	Description	Data type	Valid range	Initial value
Error	Error	Output	TRUE: Error end.*1*2 FALSE: Normal end, execution in progress, or execution condition not met.	BOOL	TRUE or FALSE	---
ErrorID	Error code		This is the error ID for an error end. The value is WORD#16#0 for a normal end.	WORD	Depends on the instruction.	
ErrorIDEx	Expansion error code		This is the error ID for an Expansion Unit Hardware Error. The value is DWORD#16#0 for a normal end.	DWORD		

*1 The value of *Error* changes to FALSE when the execution condition is no longer met after an error end.

*2 If the execution condition is no longer met when an error end occurs, the value of *Error* is TRUE for one task period and it then changes to FALSE.

Timing charts are provided below for *Execute*, *Done*, *Busy*, *Error*, *ErrorID*, and *ErrorIDEx*.

● **Normal End**

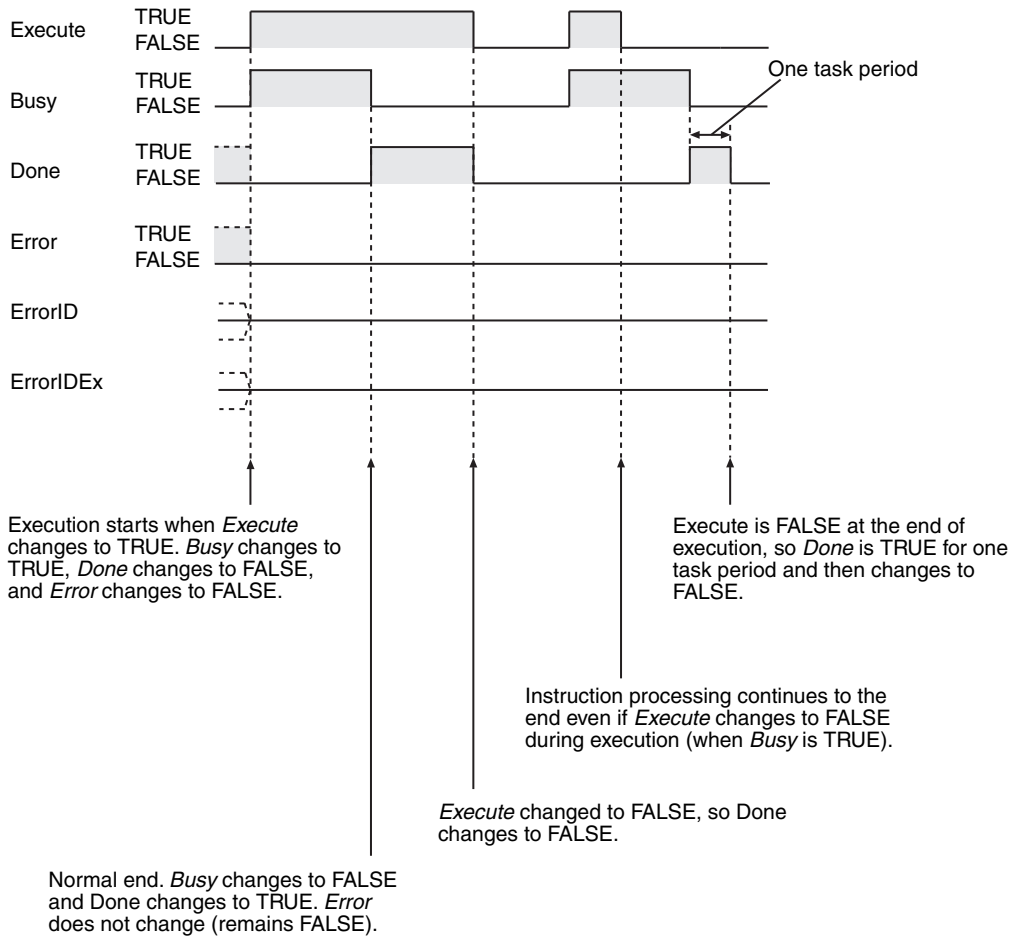

● Error End

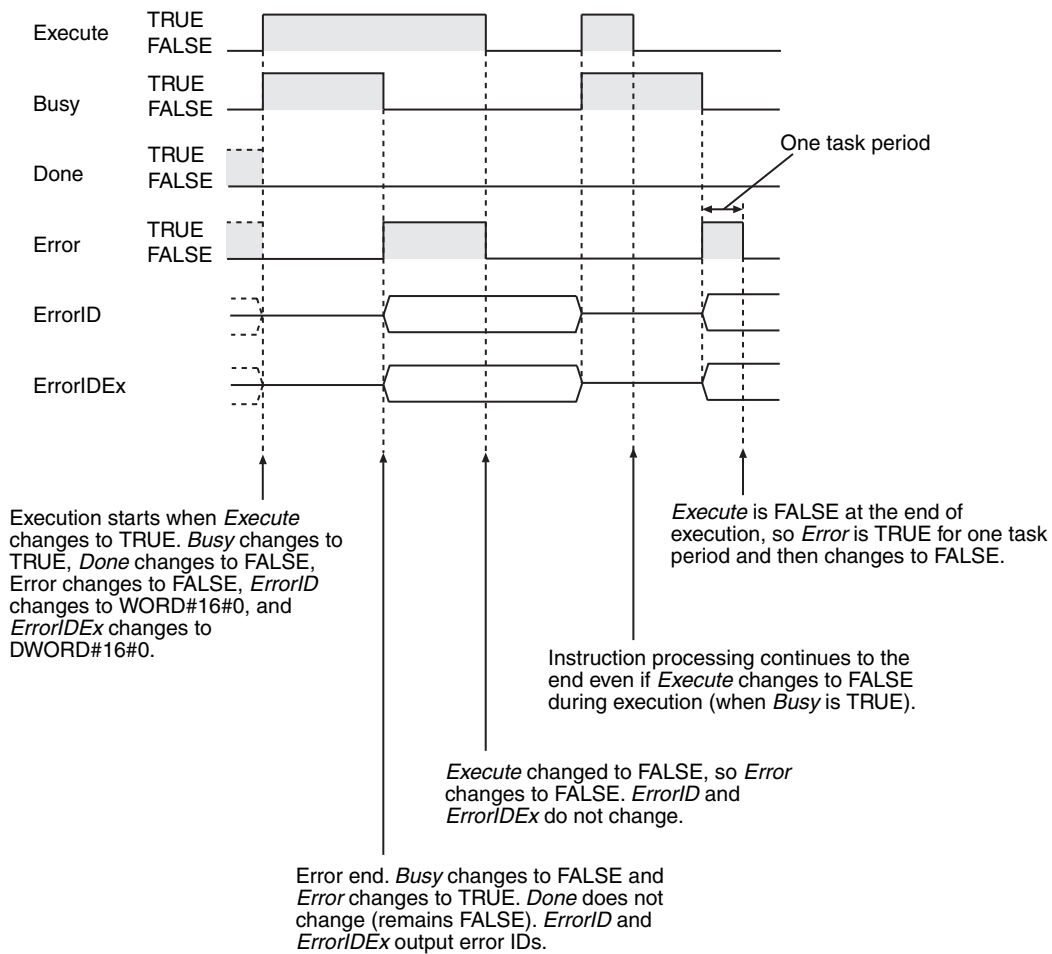

Valid Ranges and Default Values of Variables

The valid range of a variable indicates the range of values that variable can take. The default value of a variable indicates the value that is assigned to an input variable when the instruction is executed without a parameter assigned to the input variable. These values are defined for each data type. If specific values are not given for an instruction, then the valid ranges and default values of the data types are applied. These variables are indicated by “depends on data type” in the valid range column and by “---” in the input variable default column. The valid ranges and default values of the data types are given in the following tables.

Classification	Data type	Valid range	Default
Boolean	BOOL	TRUE or FALSE	FALSE
Bit string	BYTE	BYTE#16#00 to FF	BYTE#16#00
	WORD	WORD#16#0000 to FFFF	WORD#16#0000
	DWORD	DWORD#16#00000000 to FFFFFFFF	DWORD#16#0000_0000
	LWORD	LWORD#16#0000000000000000 to FFFFFFFFFFFFFFFF	LWORD#16#0000_0000_0000_0000

Classification	Data type	Valid range	Default
Integers	USINT	USINT#0 to +255	USINT#0
	UINT	UINT#0 to +65535	UINT#0
	UDINT	UDINT#0 to +4294967295	UDINT#0
	ULINT	ULINT#0 to +18446744073709551615	ULINT#0
	SINT	SINT#-128 to +127	SINT#0
	INT	INT#-32768 to +32767	INT#0
	DINT	DINT#-2147483648 to +2147483647	DINT#0
	LINT	LINT#-9223372036854775808 to +9223372036854775807	LINT#0
Real numbers	REAL	REAL#-3.402823e+38 to -1.175495e-38, 0, +1.175495e-38 to +3.402823e+38, +∞/-∞	REAL#0
	LREAL	LREAL#-1.79769313486231e+308 to -2.22507385850721e-308, 0, +2.22507385850721e-308 to +1.79769313486231e+308, +∞/-∞	LREAL#0
Times, durations, dates, and text strings	TIME	T#-9223372036854.775808ms (T#-106751d_23h_47m_16s_854.775808ms) to T#9223372036854.775807ms (T#+106751d_23h_47m_16s_854.775807ms)	T#0s
	DATE	D#1970-01-01 to D#2106-02-06 (January 1, 1970 to February 6, 2106)	D#1970-01-01
	TOD	TOD#00:00:00.000000000 to TOD#23:59:59.999999999 (0:00 and 0.000000000 to 23:59 and 59.999999999 seconds)	TOD#00:00:00.000000000
	DT	DT#1970-01-01-00:00:00.000000000 to DT#2106-02-06-23:59:59.999999999 (0:00 and 0.000000000 on January 1, 1970 to 23:59 and 59.999999999 seconds on February 6, 2106)	DT#1970-01-01-00:00:00.000000000
	STRING	Character code: UTF-8 0 to 1,986 bytes (1,985 single-byte alphanumeric characters plus the final NULL character)	"

Derivative Data Types (Enumerations, Structures, and Unions)

Variables that use derivative data types (enumerations, structures, and unions) are specified as such in the tables of variable data types. The notation is described below.

Enumerations

The data type for an enumerated variable is given within the table. The following is an example. Here, the data type of the *Out* variable is enumerated type `_eDAYOFWEEK`. The enumerators are described in the description of the function of the instruction.

	Boolean	Bit strings				Integers							Real numbers		Times, durations, dates, and text strings					
	BOOL	BYTE	WORD	DWORD	LWORD	USINT	UINT	UDINT	ULINT	SINT	INT	DINT	LINT	REAL	LREAL	TIME	DATE	TOD	DT	STRING
In																	OK		OK	
Out	Refer to <i>Function</i> for the enumerators of the enumerated type <code>_eDAYOFWEEK</code> .																			

Structures and Unions

The data type for a structure or union variable is given within the table. The following is an example. Here, the data type of the *In1* variable is structure `_sPORT`. Details on the members of a structure or union are given in the description of the function of the instruction.

	Boolean	Bit strings				Integers							Real numbers		Times, durations, dates, and text strings					
	BOOL	BYTE	WORD	DWORD	LWORD	USINT	UINT	UDINT	ULINT	SINT	INT	DINT	LINT	REAL	LREAL	TIME	DATE	TOD	DT	STRING
In1	Refer to <i>Function</i> for details on the structure <code>_sPORT</code> .																			

The tables also indicate any variables for which you can specify a structure, a structure member, a union, or a union member as the parameter.

In the following example, you can specify a parameter with a basic data type, or you can specify a structure, a structure member, a union, or a union member for the *In1* variable. To specify a structure or union, specify only the structure or the union as the parameter. To specify a structure member or a union member, specify the member as the parameter.

	Boolean	Bit strings				Integers							Real numbers		Times, durations, dates, and text strings					
	BOOL	BYTE	WORD	DWORD	LWORD	USINT	UINT	UDINT	ULINT	SINT	INT	DINT	LINT	REAL	LREAL	TIME	DATE	TOD	DT	STRING
In1	OK	OK	OK	OK	OK	OK	OK	OK	OK	OK	OK	OK	OK	OK	OK	OK	OK	OK	OK	OK
A structure, structure member, union, or union member can also be specified.																				

Array Specifications

Array variable names are followed by “[]” and “(array)” is specified. For these variables, specify an element of the array (i.e., specify the subscript) as the parameter.

An example is shown below. Here, the table shows that *In1[]* is a BYTE array.

	Boolean	Bit strings				Integers							Real numbers		Times, durations, dates, and text strings					
	BOOL	BYTE	WORD	DWORD	LWORD	USINT	UINT	UDINT	ULINT	SINT	INT	DINT	LINT	REAL	LREAL	TIME	DATE	TOD	DT	STRING
In1[] (array)		OK																		

The data type table indicates the arrays for which structures and unions can be used as elements, as shown in the following example. For these variables, specify an element of the array (i.e., specify the subscript) as the parameter.

	Boolean	Bit strings				Integers							Real numbers		Times, durations, dates, and text strings					
	BOOL	BYTE	WORD	DWORD	LWORD	USINT	UINT	UDINT	ULINT	SINT	INT	DINT	LINT	REAL	LREAL	TIME	DATE	TOD	DT	STRING
In1[] (array)		Arrays of structures or unions can also be specified.																		

The table indicates any variables for which you can specify either an array or an array element as the parameter.

In the following example, you can specify a parameter with a basic data type, or you can specify an array or an array element. To specify an array, specify only the array as the parameter. To specify an array element, specify an element of the array (i.e., specify the subscript) as the parameter.

	Boolean	Bit strings				Integers							Real numbers		Times, durations, dates, and text strings					
	BOOL	BYTE	WORD	DWORD	LWORD	USINT	UINT	UDINT	ULINT	SINT	INT	DINT	LINT	REAL	LREAL	TIME	DATE	TOD	DT	STRING
In1		An array or array element can also be specified.																		

Others

Errors Detected for All Instructions

The errors that can occur for an instruction are given in the *Precautions for Correct Use* section. The following three errors, however, can be detected for any instruction. They are not listed in the *Precautions for Correct Use* sections.

- Reading or writing elements that exceed the range of an array variable.
Example: Setting `a[4]` for an input variable for the array variable `a[0..3]`.
- Passing parameters that are not variables to instructions for which array variables are defined for input, output, or in-out variables.
- Assigning a text string that is longer than the defined number of bytes to a STRING variable.
- Assigning a text string that does not end in a NULL character to a STRING variable.
- Dividing an integer variable by 0.

Precautions for All Instructions

The amount of processing that is required for some instructions depends on the parameters that you connect. If there is too much processing, the instruction execution time increases and the task period may be exceeded. This will result in a Task Period Exceeded error. Adjust the amount of processing to a suitable amount.

Ladder Diagram Instructions

Instruction	Name	Page
LD and LDN	Load/ Load NOT	2-16
AND and ANDN	AND/ AND NOT	2-18
OR and ORN	OR/ OR NOT	2-20
Out and OutNot	Output/ Output NOT	2-22

LD and LDN

LD: Reads the value of a BOOL variable.

LDN: Reads the inverse of the value of a BOOL variable.

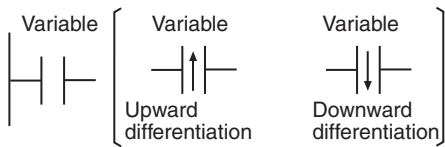
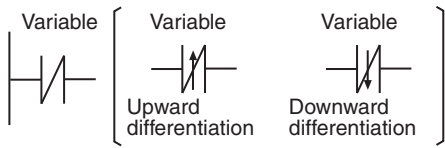
Instruction	Name	FB/FUN	Graphic expression	ST expression
LD	Load	---		None
LDN	Load NOT	---		None

Variables

None

Function

● LD

The LD instruction reads the value of the specified BOOL variable and outputs it to the next instruction. If the value of the specified variable is TRUE, then TRUE is output. If the value is FALSE, then FALSE is output. Use the LD instruction for the first NO bit from the bus bar or for the first NO bit of a logic block.

● LDN

The LD instruction reads the inverse of the value of the specified BOOL variable and outputs it to the next instruction. If the value of the specified variable is TRUE, then FALSE is output. If the value is FALSE, then TRUE is output. Use the LDN instruction for the first NC bit from the bus bar or for the first NC bit of a logic block.

The operation is as shown below if you do not specify upward or downward differentiation.

Instruction	Value of variable	Output value
LD	TRUE	TRUE
	FALSE	FALSE
LDN	TRUE	FALSE
	FALSE	TRUE

If you specify upward or downward differentiation, the operation depends on the following: the value of the variable the last time the instruction was executed and the current value of the variable. This is shown below.

Instruction	Differentiation specification	Value of variable at last execution and current value of variable	Output value
LD	Upward differentiation	FALSE at the last execution → Currently TRUE	TRUE
		Other than the above.	FALSE
	Downward differentiation	TRUE at the last execution → Currently FALSE	TRUE
		Other than the above.	FALSE
LDN	Upward differentiation	FALSE at the last execution → Currently TRUE	FALSE
		Other than the above.	TRUE
	Downward differentiation	TRUE at the last execution → Currently FALSE	FALSE
		Other than the above.	TRUE

The following figure shows a programming example and timing chart.

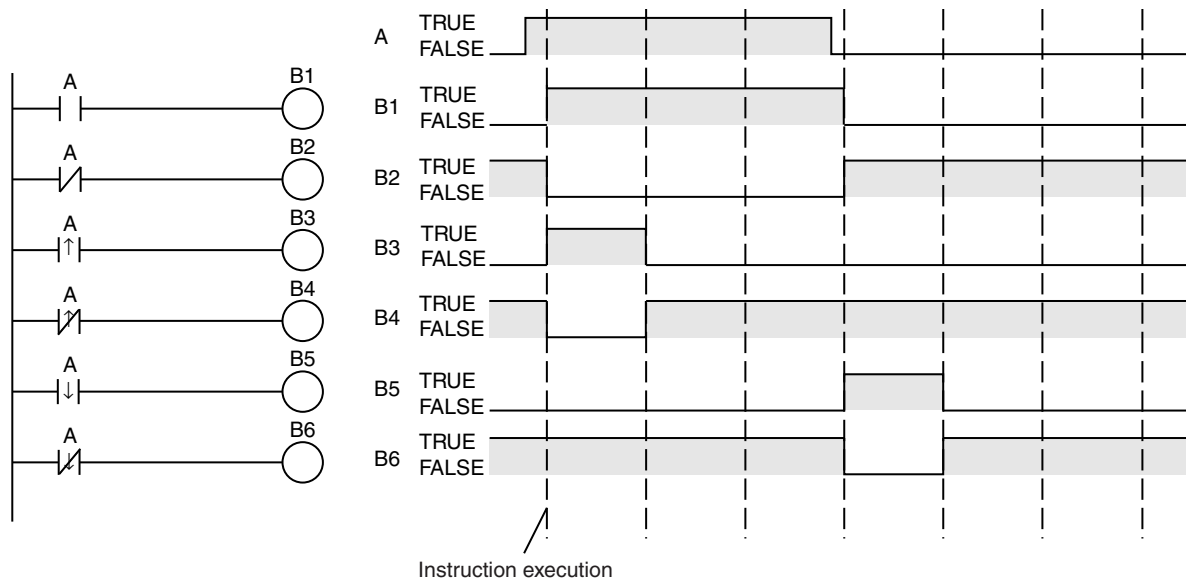

Precautions for Correct Use

- An error occurs in the following case and the output value from the last execution is retained.
 - You specify an array element for the variable value and the element does not exist.

Example: A BOOL array a[0..5] is defined, but the instruction is executed using a[10] as the variable.
- Do not use these instructions as the rightmost instruction on a rung. If you do, an error occurs on the Sysmac Studio and you cannot transfer the user program to the Controller.

AND and ANDN

AND: Takes the logical AND of the value of a BOOL variable and the execution condition.

ANDN: Takes the logical AND of the inverse of the value of a BOOL variable and the execution condition.

Instruction	Name	FB/FUN	Graphic expression	ST expression
AND	AND	---		$\text{result} := \text{vBool1 AND vBool2};$ $\text{result} := \text{vBool1 \& vBool2};$
ANDN	AND NOT	---		$\text{result} := \text{vBool1 AND NOT vBool2};$

Variables

None

Function

● AND

The AND instruction takes the logical AND of the value of a specified BOOL variable and the execution condition and outputs it to the next instruction. Use the AND instruction for a NO bit connected in series with the previous instruction.

● ANDN

The ANDN instruction takes the logical AND of the inverse of the value of a specified BOOL variable and the execution condition and outputs it to the next instruction. Use the ANDN instruction for a NC bit connected in series with the previous instruction.

The following figure shows a programming example of the AND instruction. It takes the logical AND of variable *A* and variable *B* and outputs it to variable *C*.

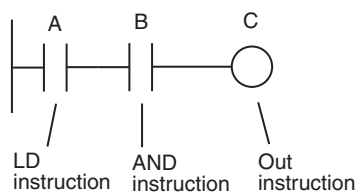

It takes the logical AND of variable *A* and variable *B* and outputs the result to variable *C*.

The operation is as shown below if you do not specify upward or downward differentiation.

Instruction	Combination of variable value and execution condition	Output value
AND	Variable value: TRUE Execution condition: TRUE	TRUE
	Other than the above.	FALSE
ANDN	Variable value: FALSE Execution condition: TRUE	TRUE
	Other than the above.	FALSE

If you specify upward or downward differentiation, the operation depends on the following: the value of the variable the last time the instruction was executed, the current value of the variable, and the execution condition. This is shown below.

Instruction	Differentiation specification	Combination of value of variable at last execution, current value of variable, and execution condition	Output value
AND	Upward differentiation	Variable value: FALSE at the last execution → Currently TRUE Execution condition: TRUE	TRUE
		Other than the above.	FALSE
	Downward differentiation	Variable value: TRUE at the last execution → Currently FALSE Execution condition: TRUE	TRUE
		Other than the above.	FALSE
ANDN	Upward differentiation	Variable value: FALSE at the last execution → Currently TRUE Execution condition: TRUE	FALSE
		Variable value: Ignored Execution condition: FALSE	
		Other than the above.	TRUE
	Downward differentiation	Variable value: TRUE at the last execution → Currently FALSE Execution condition: TRUE	FALSE
		Variable value: Ignored Execution condition: FALSE	
		Other than the above.	TRUE

Precautions for Correct Use

- An error occurs in the following case and the output value from the last execution is retained.
 - You specify an array element for the variable value and the element does not exist.

Example: A BOOL array a[0..5] is defined, but the instruction is executed using a[10] as the variable.
- Do not use these instructions as the rightmost instruction on a rung. If you do, an error occurs on the Sysmac Studio and you cannot transfer the user program to the Controller.
- You cannot connect these instructions directly to the bus bar.

OR and ORN

OR: Takes the logical OR of the value of a BOOL variable and the execution condition.

ORN: Takes the logical OR of the inverse of the value of a BOOL variable and the execution condition.

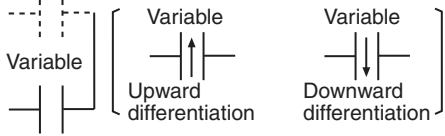
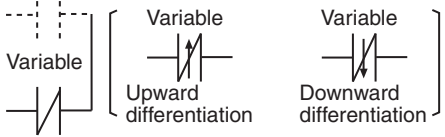
Instruction	Name	FB/FUN	Graphic expression	ST expression
OR	OR	---		result:=vBool1 OR vBool2;
ORN	OR NOT	---		result:=vBool1 OR NOT vBool2;

Variables

None

Function

● OR

The OR instruction takes the logical OR of the value of a specified BOOL variable and the execution condition and outputs it to the next instruction. Use the OR instruction for a NO bit connected in parallel with the previous instruction. Use the OR instruction to configure a logical OR between an NO bit and one of the following: a LD or LDN instruction connected directly to the bus bar, or the logic block starting with a LD or LDN instruction and ending with the instruction immediately before the OR instruction.

● ORN

The ORN instruction takes the logical OR of the inverse of the value of a specified BOOL variable and the execution condition and outputs it to the next instruction. Use the ORN instruction for a NC bit connected in parallel with the previous instruction. Use the ORN instruction to configure a logical OR between an NC bit and one of the following: a LD or LDN instruction connected directly to the bus bar, or the logic block starting with a LD or LDN instruction and ending with the instruction immediately before the ORN instruction.

The following figure shows a programming example of the OR instruction. It takes the logical OR of variable *A* and variable *B* and outputs it to variable *C*.

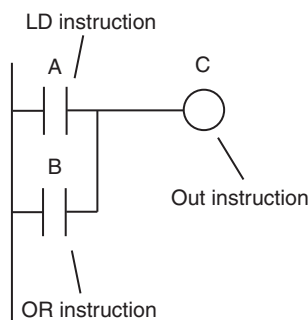



It takes the logical OR of variable *A* and variable *B* and outputs the result to variable *C*.

The operation is as shown below if you do not specify upward or downward differentiation.

Instruction	Combination of variable value and execution condition	Output value
OR	Variable value: FALSE Execution condition: FALSE	FALSE
	Other than the above.	TRUE
ORN	Variable value: TRUE Execution condition: FALSE	FALSE
	Other than the above.	TRUE

If you specify upward or downward differentiation, the operation depends on the following: the value of the variable the last time the instruction was executed, the current value of the variable, and the execution condition. This is shown below.

Instruction	Differentiation specification	Combination of value of variable at last execution, current value of variable, and execution condition	Output value
OR	Upward differentiation	Variable value: FALSE at the last execution → Currently TRUE Execution condition: Ignored.	TRUE
		Variable value: Ignored Execution condition: TRUE	TRUE
		Other than the above.	FALSE
	Downward differentiation	Variable value: TRUE at the last execution → Currently FALSE Execution condition: Ignored.	TRUE
		Variable value: Ignored Execution condition: TRUE	TRUE
		Other than the above.	FALSE
ORN	Upward differentiation	Variable value: FALSE at the last execution → Currently TRUE Execution condition: FALSE	FALSE
		Other than the above.	TRUE
	Downward differentiation	Variable value: TRUE at the last execution → Currently FALSE Execution condition: FALSE	FALSE
		Other than the above.	TRUE

Precautions for Correct Use

- An error occurs in the following case and the output value from the last execution is retained.
 - You specify an array element for the variable value and the element does not exist.

Example: A BOOL array `a[0..5]` is defined, but the instruction is executed using `a[10]` as the variable.
- Do not use these instructions as the rightmost instruction on a rung. If you do, an error occurs on the Sysmac Studio and you cannot transfer the user program to the Controller.

Out and OutNot

Out: Takes the logical result from the previous instruction and outputs it to a BOOL variable.

OutNot: Takes the inverse of the logical result from the previous instruction and outputs it to a BOOL variable.

Instruction	Name	FB/FUN	Graphic expression	ST expression
Out	Output	---	<p>Variable</p> <p>Variable</p> <p>Upward differentiation</p> <p>Downward differentiation</p>	Variable:=(Logic expression up to previous instruction);
OutNot	Output NOT	---	<p>Variable</p>	Variable:=NOT(Logic expression up to previous instruction);

Variables

None

Function

● Out

The Out instruction takes the logical result from the previous instruction and outputs it to a specified BOOL variable.

The operation is as shown below if you do not specify upward or downward differentiation.

Logic processing result from previous instruction	Output
TRUE	TRUE
FALSE	FALSE

You can specify upward or downward differentiation for the Out instruction. If upward or downward differentiation is specified, the output value is determined by changes in the result of logic processing from the previous instruction between the last execution of the instruction and the current execution. The operation is according to the current logical result from the previous instruction, as shown in the following table.

Differentiation specification	Results of logic processing from the previous execution and current execution	Output
Upward differentiation	FALSE at the last execution → Currently TRUE	TRUE
	Other than the above.	FALSE
Downward differentiation	TRUE at the last execution → Currently FALSE	TRUE
	Other than the above.	FALSE

● OutNot

The OutNot instruction takes the inverse of the logical result from the previous instruction and outputs it to a specified BOOL variable.

Logic processing result from previous instruction	Output
TRUE	FALSE
FALSE	TRUE

The following figure shows a programming example and timing chart.

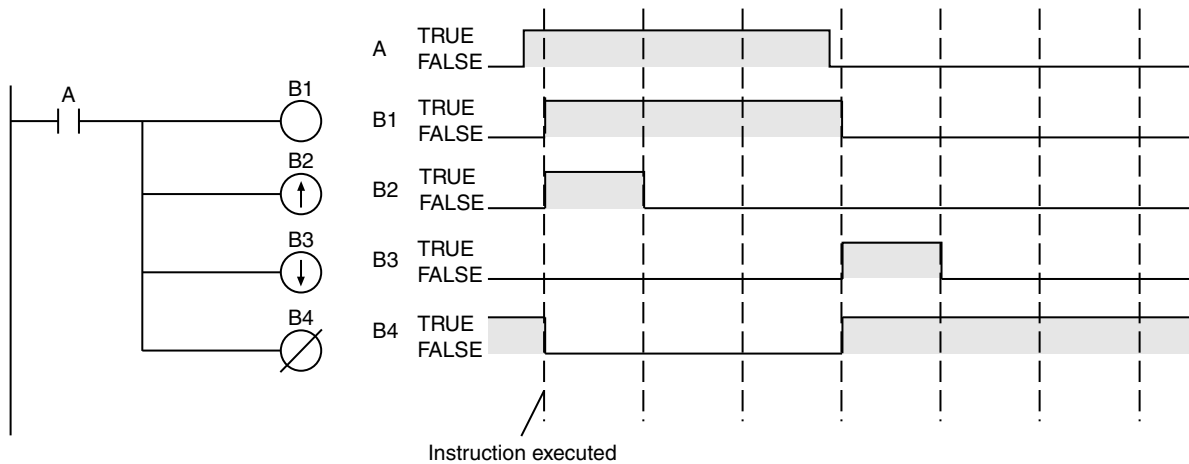

Additional Information

Differences between the Set and Reset Instructions and the Out and OutNot Instructions

- The Set and Reset instructions operate only when the input value changes to TRUE. They do not operate when the input value is FALSE. When the input value is FALSE, the output does not change.
- The Out and OutNot instructions affect the output whether the logical result of the previous instruction is TRUE or FALSE.

Precautions for Correct Use

- In the following case, an error occurs and nothing is output.
 - You specify an array element for the variable value and the element does not exist.

Example: A BOOL array a[0..5] is defined, but the instruction is executed using a[10] as the variable.

- The following connections are possible.
 - You can connect another Out instruction after an Out instruction.

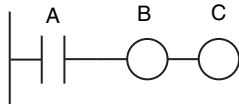

- You can connect an LD instruction and Out instruction after an Out instruction.

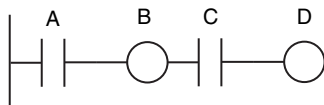

- The following connections are not possible.
 - You cannot connect only an LD instruction after an Out instruction.

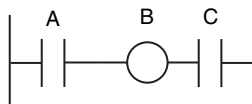

- Functions and function blocks cannot be connected after an Out instruction.

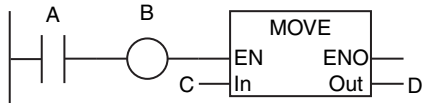

- Branches and joins cannot be used after Out instructions.

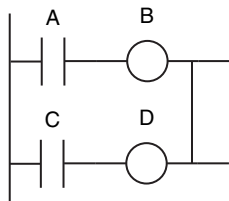
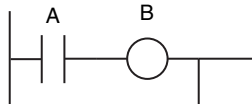

ST Statement Instructions

Instruction	Name	Page
IF	If	2-26
CASE	Case	2-30
WHILE	While	2-34
REPEAT	Repeat	2-36
EXIT	Break Loop	2-38
RETURN	Return	2-41
FOR	Repeat Start	2-42

IF

The IF construct uses the evaluation result of a specified condition expression to select one of two statements to execute.

Instruction	Name	FB/FUN	Graphic expression	ST expression
IF	If	---	None	IF <i>condition expression</i> THEN <i>statement</i> ; ELSIF <i>condition expression</i> THEN <i>statement</i> ; ELSE <i>statement</i> ; END_IF;

Variables

None

Function

The IF construct uses the evaluation result of a specified condition expression to select one of two statements to execute. Use a condition expression that evaluates to TRUE or FALSE.

Item used for condition expression	Example	Evaluation result
Logic expression	a>3	If the value of variable <i>a</i> is greater than 3, the result is TRUE. Otherwise, the result is FALSE.
	a=b	If the values of variables <i>a</i> and <i>b</i> are equal, the result is TRUE. Otherwise, the result is FALSE.
BOOL variable	abc	If the value of variable <i>abc</i> is TRUE, the result is TRUE. If it is FALSE, the result is FALSE.
BOOL constant	TRUE	TRUE
Function with a BOOL return value	FUN name	If the function returns TRUE, the result is TRUE. If it returns FALSE, the result is FALSE.

You can use the following operators in the logic expression.

Operator	Meaning	Example	Evaluation result
=	Equals	a=b	If the values of variables <i>a</i> and <i>b</i> are equal, the result is TRUE. Otherwise, the result is FALSE.
<>	Not equals	a<>b	If the values of variables <i>a</i> and <i>b</i> are not equal, the result is TRUE. Otherwise, the result is FALSE.
<	Comparison	a<b	If the value of variable <i>a</i> is less than the value of variable <i>b</i> , the result is TRUE. Otherwise, the result is FALSE.
<=		a<=b	If the value of variable <i>a</i> is less than or equal to the value of variable <i>b</i> , the result is TRUE. Otherwise, the result is FALSE.
>		a>b	If the value of variable <i>a</i> is greater than the value of variable <i>b</i> , the result is TRUE. Otherwise, the result is FALSE.
>=		a>=b	If the value of variable <i>a</i> is greater than or equal to the value of variable <i>b</i> , the result is TRUE. Otherwise, the result is FALSE.
AND (&)	Logical AND	a AND b a & b	The result is the logical AND of BOOL variables <i>a</i> and <i>b</i> .

Operator	Meaning	Example	Evaluation result
OR	Logical OR	a OR b	The result is the logical OR of BOOL variables <i>a</i> and <i>b</i> .
XOR	Exclusive OR	a XOR b	The result is the logical exclusive OR of BOOL variables <i>a</i> and <i>b</i> .
NOT	NOT	NOT a	The result is the NOT of BOOL variable <i>a</i> .

The flowchart in the following example shows the evaluation results for condition expressions 1 and 2. You can use more than one statement for each of statements 1 to 3.

```

IF condition expression 1 THEN
  statement 1;
ELSIF condition expression 2 THEN
  statement 2;
ELSE
  statement 3;
END_IF;

```

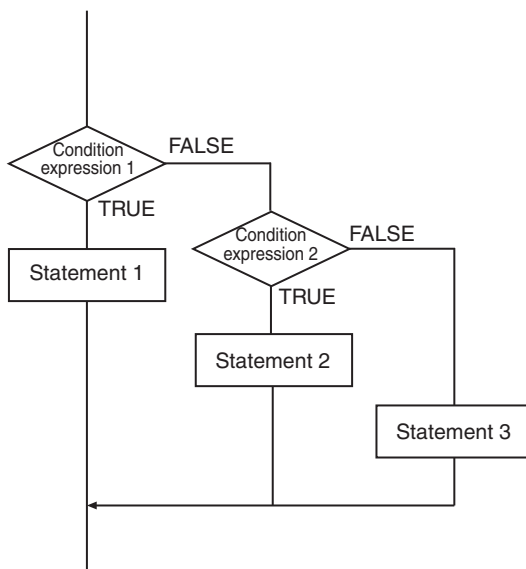

Additional Information

- You can use the IF construct to build a hierarchy. The following example executes statement 11 if the evaluation results of both condition expression 1 and condition expression 11 are TRUE.

```

IF condition expression 1 THEN
  IF condition expression 11 THEN
    statement 11;
  ELSIF condition expression 12 THEN
    statement 12;
  ELSE
    statement 13;
  END_IF;
ELSIF condition expression 2 THEN
  statement 2;
ELSE
  statement 3;
END_IF;

```

You can use ELSIF more than once. The following processing flow is for this example.

```

IF condition expression 1 THEN
  statement 1;
ELSIF condition expression 2 THEN
  statement 2;
ELSIF condition expression 3 THEN
  statement 3;
ELSE
  statement 4;
END_IF;
  
```

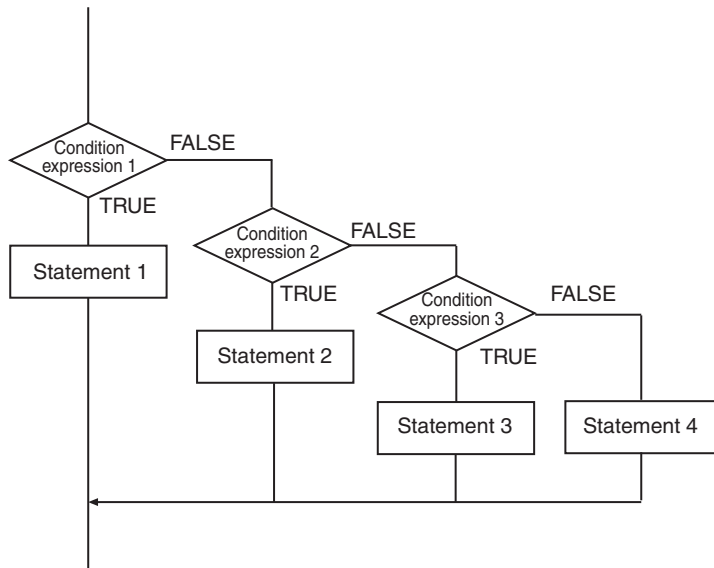

- You do not use ELSIF if there is only one condition expression. You do not use ELSE if no processing is performed when none of the condition expressions are TRUE. The following processing flow is for this example.

```

IF condition expression THEN
  statement;
END_IF;
  
```

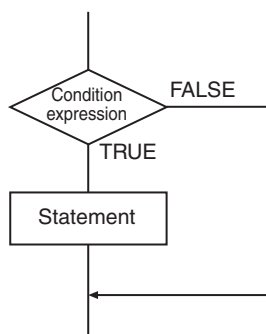

- There are no restrictions on the statements that you can use. You can use the same types of statements for the statements in the IF construct as you do for the statements outside the IF construct. For example, you can use function block calls and FOR constructs.

Precautions for Correct Use

- You must always use IF and END_IF. They must be paired.
- You can use a hierarchy that is 15 levels deep, but count all levels of IF, CASE, FOR, WHILE, and REPEAT constructs.

Sample Programming

This example assigns INT#0 to variable *def* if the value of variable *abc* is less than INT#0. It assigns INT#1 to variable *def* and INT#2 to variable *ghi* if the value of variable *abc* is INT#0. It assigns INT#3 to variable *def* if the value of variable *abc* is none of the above.

Variable	Data type	Initial value
abc	INT	0
def	INT	0
ghi	INT	0

```

IF (abc<INT#0) THEN
  def:=INT#0;
ELSIF (abc=INT#0) THEN
  def:=INT#1;
  ghi:=INT#2;
ELSE
  def:=INT#3;
END_IF;

```

CASE

You use the CASE construct to select the statement to execute based on the value of a specified integer expression.

Instruction	Name	FB/FUN	Graphic expression	ST expression
CASE	Case	---	None	CASE <i>integer expression</i> OF <i>value:</i> <i>statement</i> ; <i>value:</i> <i>statement</i> ; : : ELSE <i>statement</i> ; END_CASE;

Variables

None

Function

You use the CASE construct to select the statement to execute based on the value of a specified integer expression.

You can use any of the following as the integer expression and values.

	Allowed notation
Integer expression	Integer variable, integer constant, integer expression, or a function that returns an integer return value, enumeration variable, enumeration expression, or enumerator
Values	Integer constants

The flowchart in the following example shows the processing flow for an integer expression. You can use more than one statement for each of the statements.

CASE *integer expression* OF

```

1 :
    statement 1;
2 :
    statement 2;
:
:
n :
    statement n;
ELSE
    statement m;
END_CASE;
```

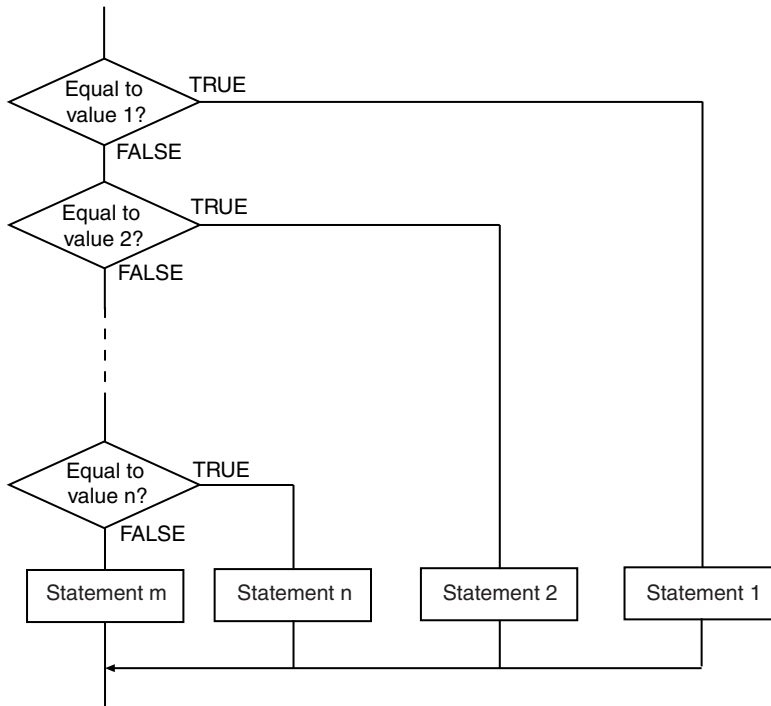

Additional Information

- You can use the CASE construct to build a hierarchy. The following example executes statement 12 if the value of integer expression 1 is 1 and the value of integer expression 11 is 2.

```

CASE integer expression 1 OF
  1 :
    CASE integer expression 1 OF
      1 :
        statement 11;
      2 :
        statement 12;
    ELSE
      statement 1m;
    END_CASE;
  2 :
    statement 2;
  3 :
    statement 3;
  ELSE
    statement m;
END_CASE;

```

- You can use more than one value at the same time. Separate values with commas. The following example executes statement 1 if the value of the integer expression is either 1 or 2.

```

CASE integer expression 1 OF
  1,2 :
    statement 1;
  3 :
    statement 2;
  4 :
    statement 3;
  ELSE
    statement m;
END_CASE;

```

- You can use a range of consecutive values. Place two periods between the numbers to indicate consecutive values. The following example executes statement 1 if the value of the integer expression is between 10 and 15, inclusive.

```

CASE integer expression 1 OF
  10..15:
    statement 1;
  16:
    statement 2;
  17:
    statement 3;
  ELSE
    statement m;
END_CASE;

```

- You can omit ELSE. If you do, none of the statements is executed if none of the values is equal to the value of the integer expression.
- There are no restrictions on the statements that you can use. You can use the same types of statements for the statements in the CASE construct as you do for the statements outside the CASE construct. For example, you can use function block calls and FOR constructs.
- The following is different in comparison to a C language *switch* statement. With a C language *switch* statement, all statements after a value that equals the integer expression are executed unless a *break* statement is used. With the CASE statement, only the statements that correspond directly to the value that equals the integer expression are executed. For example, in the following example, statements 1 to 3 are executed for the C language *switch* statement. Here, only statement 1 is executed for the CASE instruction.

C Language switch Statement	CASE Instruction
val=1;	val:=1;
switch val	CASE val OF
{	1:
case 1:	<i>statement 1</i> ;
<i>statement 1</i> ;	2:
case 2:	<i>statement 2</i> ;
<i>statement 2</i> ;	3:
case 3:	<i>statement 3</i> ;
<i>statement 3</i> ;	END_CASE;
}	

Precautions for Correct Use

- You must always use CASE and END_CASE. They must be paired.
- The data types of the integer expression and values can be different.
- Each value can be given only once.
- You can use a hierarchy that is 15 levels deep, but count all levels of IF, CASE, FOR, WHILE, and REPEAT constructs.

Sample Programming

This example assigns INT#10 to variable *def* if the value of variable *abc* is INT#1, INT#20 if the value of variable *abc* is INT#2, and INT#30 if the value of variable *abc* is INT#3. Otherwise, it assigns the value of variable *ghi* to variable *def*.

Variable	Data type	Initial value
abc	INT	0
def	INT	0
ghi	INT	0

```

CASE abc OF
  INT#1 :
    def:=INT#10;
  INT#2 :
    def:=INT#20;
  INT#3 :
    def:=INT#30;
  ELSE
    def:=ghi;
END_CASE;

```

This example assigns INT#10 to variable *def* if the value of variable *abc* is INT#1, INT#20 if the value of variable *abc* is INT#2 or INT#5, and INT#30 if the value of variable *abc* is between INT#6 and INT#10, inclusive. Otherwise, it does nothing.

Variable	Data type	Initial value
abc	INT	0
def	INT	0

```

CASE abc OF
  INT#1 :
    def:=INT#10;
  INT#2, INT#5 :
    def:=INT#20;
  INT#6..INT#10 :
    def:=INT#30;
END_CASE;

```

WHILE

The WHILE construct repeatedly executes a statement as long as the evaluation result of a specified condition expression is TRUE.

Instruction	Name	FB/FUN	Graphic expression	ST expression
WHILE	While	---	None	WHILE <i>condition expression</i> DO <i>statement</i> ; END_WHILE;

Variables

None

Function

The WHILE construct repeatedly executes a statement as long as the evaluation result of a specified condition expression is TRUE. Use a condition expression that evaluates to TRUE or FALSE.

Item used for condition expression	Example	Evaluation result
Logic expression	$a > 3$	If the value of variable <i>a</i> is greater than 3, the result is TRUE. Otherwise, the result is FALSE.
	$a = b$	If the values of variables <i>a</i> and <i>b</i> are equal, the result is TRUE. Otherwise, the result is FALSE.
BOOL variable	<i>abc</i>	If the value of variable <i>abc</i> is TRUE, the result is TRUE. If it is FALSE, the result is FALSE.
BOOL constant	TRUE	TRUE
Function with a BOOL return value	FUN name	If the function returns TRUE, the result is TRUE. If it returns FALSE, the result is FALSE.

You can use the following operators in the logic expression.

Operator	Meaning	Example	Evaluation result
=	Equals	$a = b$	If the values of variables <i>a</i> and <i>b</i> are equal, the result is TRUE. Otherwise, the result is FALSE.
<>	Not equals	$a <> b$	If the values of variables <i>a</i> and <i>b</i> are not equal, the result is TRUE. Otherwise, the result is FALSE.
<	Comparison	$a < b$	If the value of variable <i>a</i> is less than the value of variable <i>b</i> , the result is TRUE. Otherwise, the result is FALSE.
<=		$a <= b$	If the value of variable <i>a</i> is less than or equal to the value of variable <i>b</i> , the result is TRUE. Otherwise, the result is FALSE.
>		$a > b$	If the value of variable <i>a</i> is greater than the value of variable <i>b</i> , the result is TRUE. Otherwise, the result is FALSE.
>=		$a >= b$	If the value of variable <i>a</i> is greater than or equal to the value of variable <i>b</i> , the result is TRUE. Otherwise, the result is FALSE.
AND (&)	Logical AND	$a \text{ AND } b$ $a \ \& \ b$	The result is the logical AND of BOOL variables <i>a</i> and <i>b</i> .
OR	Logical OR	$a \text{ OR } b$	The result is the logical OR of BOOL variables <i>a</i> and <i>b</i> .
XOR	Exclusive OR	$a \text{ XOR } b$	The result is the logical exclusive OR of BOOL variables <i>a</i> and <i>b</i> .
NOT	NOT	NOT <i>a</i>	The result is the NOT of BOOL variable <i>a</i> .

The following processing flow is for this example. You can use more than one statement.

```
WHILE condition expression DO
  statement;
END_WHILE;
```

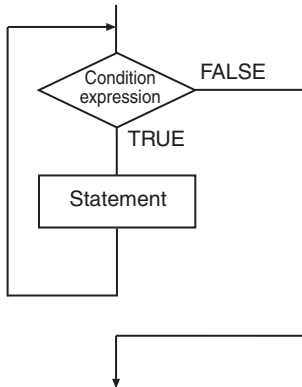

Additional Information

- The statement is not executed even once if the condition expression is FALSE the first time it is evaluated.
- There are no restrictions on the statements that you can use. You can use the same types of statements for the statements in the WHILE construct as you do for the statements outside the WHILE construct. For example, you can use function block calls and FOR constructs.

Precautions for Correct Use

- You must always use WHILE and END_WHILE. They must be paired.
- You can use a hierarchy that is 15 levels deep, but count all levels of IF, CASE, FOR, WHILE, and REPEAT constructs.

Sample Programming

This example adds INT#7 to variable *abc* as long as the value of variable *abc* is less than or equal to INT#1000.

Variable	Data type	Initial value
abc	INT	0

```
abc := INT#0;
WHILE abc <= INT#1000 DO
  abc := abc + INT#7;
END_WHILE;
```

REPEAT

The REPEAT construct executes a statement once and then executes it repeatedly until a specified condition expression is TRUE.

Instruction	Name	FB/FUN	Graphic expression	ST expression
REPEAT	Repeat	---	None	REPEAT <i>statement</i> ; UNTIL condition expression END_REPEAT;

Variables

None

Function

The REPEAT construct executes a statement once and then executes it repeatedly until a specified condition expression is TRUE. Use a condition expression that evaluates to TRUE or FALSE.

Item used for condition expression	Example	Evaluation result
Logic expression	$a > 3$	If the value of variable a is greater than 3, the result is TRUE. Otherwise, the result is FALSE.
	$a = b$	If the values of variables a and b are equal, the result is TRUE. Otherwise, the result is FALSE.
BOOL variable	abc	If the value of variable abc is TRUE, the result is TRUE. If it is FALSE, the result is FALSE.
BOOL constant	TRUE	TRUE
Function with a BOOL return value	FUN name	If the function returns TRUE, the result is TRUE. If it returns FALSE, the result is FALSE.

You can use the following operators in the logic expression.

Operator	Meaning	Example	Evaluation result
=	Equals	$a = b$	If the values of variables a and b are equal, the result is TRUE. Otherwise, the result is FALSE.
<>	Not equals	$a <> b$	If the values of variables a and b are not equal, the result is TRUE. Otherwise, the result is FALSE.
<	Comparison	$a < b$	If the value of variable a is less than the value of variable b , the result is TRUE. Otherwise, the result is FALSE.
<=		$a <= b$	If the value of variable a is less than or equal to the value of variable b , the result is TRUE. Otherwise, the result is FALSE.
>		$a > b$	If the value of variable a is greater than the value of variable b , the result is TRUE. Otherwise, the result is FALSE.
>=		$a >= b$	If the value of variable a is greater than or equal to the value of variable b , the result is TRUE. Otherwise, the result is FALSE.
AND (&)	Logical AND	a AND b a & b	The result is the logical AND of BOOL variables a and b .
OR	Logical OR	a OR b	The result is the logical OR of BOOL variables a and b .
XOR	Exclusive OR	a XOR b	The result is the logical exclusive OR of BOOL variables a and b .
NOT	NOT	NOT a	The result is the NOT of BOOL variable a .

The following processing flow is for this example. You can use more than one statement.

```
REPEAT
  statement;
UNTIL condition expression
END_REPEAT;
```

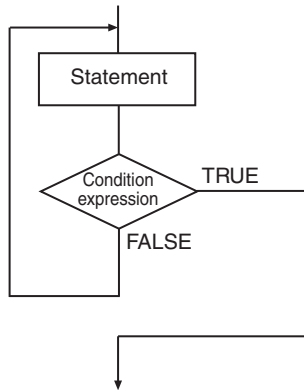

Additional Information

- The statement is executed once before the condition expression is evaluated. Therefore, the statement is always executed at least once.
- There are no restrictions on the statements that you can use. You can use the same types of statements for the statements in the REPEAT construct as you do for the statements outside the REPEAT construct. For example, you can use function block calls and FOR constructs.

Precautions for Correct Use

- You must always use REPEAT, UNTIL, and END_REPEAT. They must be used as a set.
- You can use a hierarchy that is 15 levels deep, but count all levels of IF, CASE, FOR, WHILE, and REPEAT constructs.

Sample Programming

This example adds INT#1 to variable *abc* until the value of variable *abc* exceeds INT#10.

Variable	Data type	Initial value
abc	INT	0

```
abc := INT#0;
REPEAT
  abc := abc + INT#1;
UNTIL abc > INT#10
END_REPEAT;
```

EXIT

The EXIT instruction is used to end repeat processing from the lowest level FOR, WHILE, or REPEAT instruction.

Instruction	Name	FB/FUN	Graphic expression	ST expression
EXIT	Break Loop	---	None	FOR Index:=0 TO 9 BY 1 DO IF Error[Index] THEN EXIT; END_IF; END_FOR;

Variables

None

Function

The EXIT instruction is used to end repeat processing from the lowest level FOR, WHILE, or REPEAT instruction. Processing moves to the next instruction after the repeat processing.

In the following programming, the value of variable *A* is checked every repetition during repeat processing for the FOR instruction. If the value of variable *A* is TRUE, the EXIT instruction is executed and the repeat processing is ended. If that occurs, *C:=B*; following END_IF is not executed and the value of variable *C* is retained.

```
FOR position:=INT#0 TO INT#10 BY INT#1 DO
  IF (A=TRUE) THEN
    EXIT;
  END_IF;
  C:=B;
END_FOR;
```

The flowchart for this programming is given below.

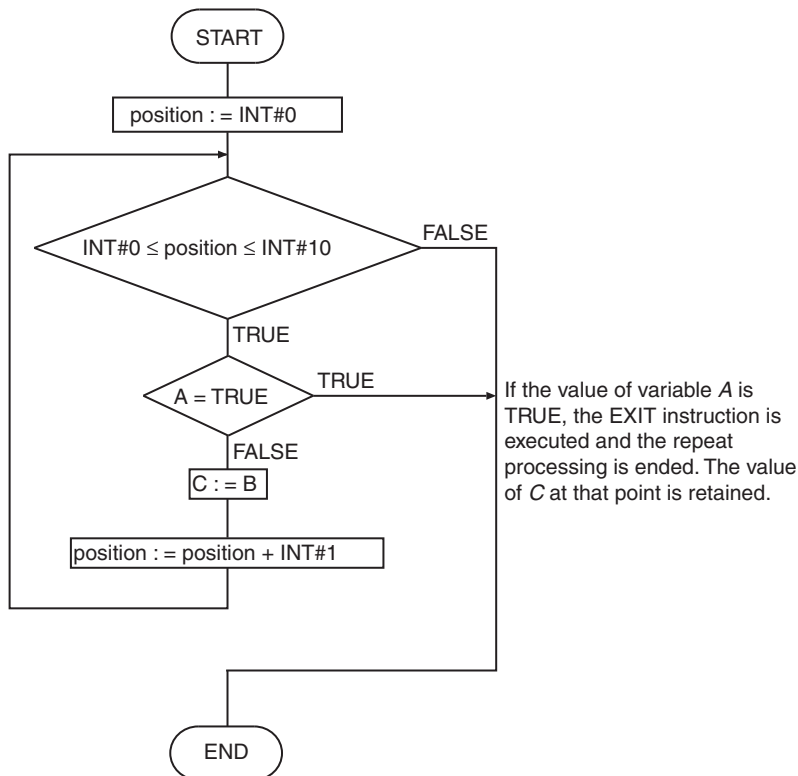

When the EXIT instruction is executed, only the lowest level of repeat processing is ended. Therefore, in the following programming, when the value of variable *B* is TRUE, EXIT instruction 2 is executed and the repeat processing for WHILE instruction 2 is ended. As the result, processing moves to $x:=x+1$;. In this case, repeat processing for WHILE instruction 1 (one level higher) is continued.

If the value of variable *A* is TRUE, EXIT instruction 1 is executed and the repeat processing for WHILE instruction 1 is ended. As the result, processing moves to $C:=D$;

```

x:=INT#0;
y:=INT#0;
WHILE x<=INT#10 DO           // WHILE instruction 1
  IF (A=TRUE) THEN           // EXIT instruction 1
    EXIT;
  END_IF;
  WHILE y<=INT#20 DO         // WHILE instruction 2
    IF (B=TRUE) THEN         // EXIT instruction 2
      EXIT;
    END_IF;
    y := y+1;
  END_WHILE;
  x = x+1;
END_WHILE
C:=D;
  
```

The flowchart for this programming is given below.

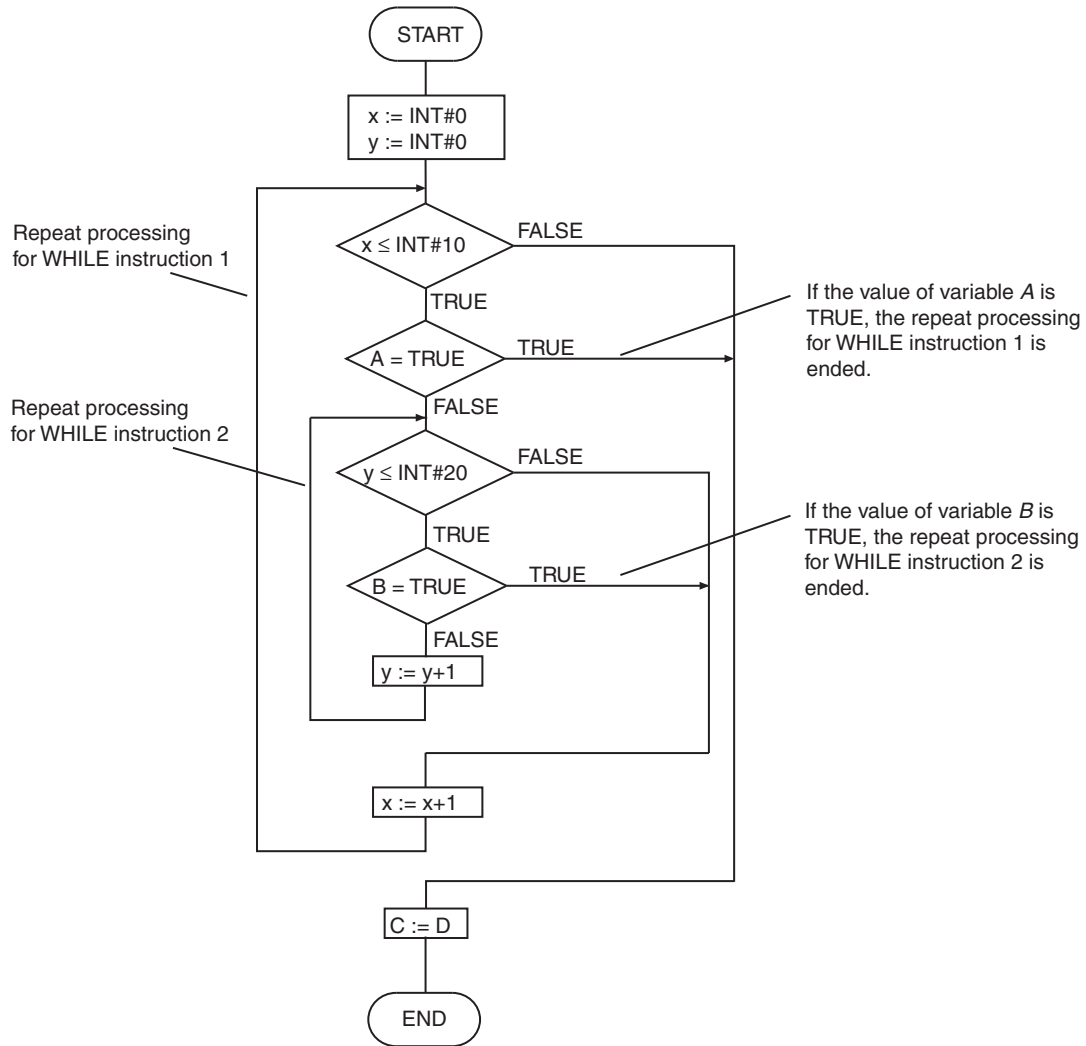

Precautions for Correct Use

- Always place this instruction between the FOR and END_FOR, WHILE and END_WHILE, or REPEAT and END_REPEAT instructions.
- If you nest repeat processing, one EXIT instruction is required for each nesting level to end all of the repeat processing.

RETURN

Refer to *RETURN* on page 2-67 in the Sequence Control Instructions for a description of this instruction.

FOR

Refer to *FOR* and *NEXT* on page 2-82 in the Sequence Control Instructions for a description of this instruction.

Sequence Input Instructions

Instruction	Name	Page
R_TRIG (Up) and F_TRIG (Down)	Up Trigger/ Down Trigger	2-44
TestABit and TestABitN	Test A Bit/ Test A Bit NOT	2-47

R_TRIG (Up) and F_TRIG (Down)

R_TRIG (Up): Outputs TRUE for one task period only when the input signal changes to TRUE.

F_TRIG (Down): Outputs TRUE for one task period only when the input signal changes to FALSE.

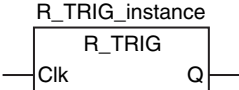
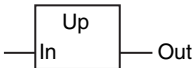
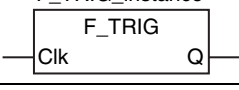
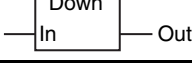
Instruction	Name	FB/FUN	Graphic expression	ST expression
R_TRIG	Up Trigger	FB		R_TRIG_instance(Clk, Q);
Up		FUN		None
F_TRIG	Down Trigger	FB		F_TRIG_instance(Clk, Q);
Down		FUN		None

Variables

Name	Meaning	I/O	Description	Valid range	Unit	Default
Clk, In	Input signal	Input	Input signal	Depends on data type.	---	---
Q, Out	Output signal	Output	Output signal	Depends on data type.	---	---

	Boolean	Bit strings					Integers							Real numbers		Times, durations, dates, and text strings				
	BOOL	BYTE	WORD	DWORD	LWORD	USINT	UINT	UDINT	ULINT	SINT	INT	DINT	LINT	REAL	LREAL	TIME	DATE	TOD	DT	STRING
Clk, In	OK																			
Q, Out	OK																			

Function

● R_TRIG

R_TRIG assigns TRUE to output signal *Q* for one task period only when input signal *Clk* changes to TRUE. Otherwise, the value of *Q* is FALSE.

● Up

The functions of the R_TRIG instruction and the Up instruction are the same. The *Clk* variable of the F_TRIG instruction corresponds to the *In* variable of the Down instruction. The *Q* variable corresponds to the *Out* variable. However, the operation of the Up instruction is different from the operation of the R_TRIG instruction in the first task period in which it is executed. Refer to the *Precautions for Correct Use* for the operation of the Up instruction in the first task period in which it is executed.

Precautions for Correct Use

- Detection of upward or downward differentiation depends on differences between the current value of *Clk* or *In* and the value the last time the instruction was executed. Caution is required when using the JMP instruction or other times that the instruction is not executed every task period.
- If power is interrupted, the value of *Clk* or *In* is not detected as FALSE. The value of *Clk* or *In* is detected as FALSE only if the instruction evaluates the value of *Clk* or *In* while *Clk* or *In* is FALSE.
- In the first task period in which the Up instruction is executed, the value of *Out* is FALSE regardless of the value of *In*.
- If the value of *In* in the Up instruction is TRUE when the power supply is turned ON, the value of *Out* remains FALSE until the value of *In* changes to FALSE and then to TRUE.
- In the first task period in which the F_TRIG instruction is executed, the value of *Q* is FALSE regardless of the value of *Clk*.
- If the value of *Clk* in the F_TRIG instruction is FALSE when the power supply is turned ON, the value of *Q* remains FALSE until the value of *Clk* changes to TRUE and then to FALSE.
- In the first task period in which the Down instruction is executed, the value of *Out* is FALSE regardless of the value of *In*.
- If the value of *In* in the Down instruction is FALSE when the power supply is turned ON, the value of *Out* remains FALSE until the value of *In* changes to TRUE and then to FALSE.



Version Information

The value of *Q* when the R_TRIG instruction is executed and the value of *Clk* is TRUE depends on the unit version of the CPU Unit and the timing of execution of the instruction, as described in the following table.

Timing of execution of R_TRIG when <i>Clk</i> is TRUE	Value of <i>Q</i>	
	CPU Unit with unit version 1.02 or later	CPU Unit with unit version 1.01 or earlier
Task period in which R_TRIG is first executed	The value of <i>Q</i> is TRUE.	The value of <i>Q</i> is always FALSE.
When the power supply is turned ON	The value of <i>Q</i> is TRUE.	The value of <i>Q</i> remains FALSE until the value of <i>Clk</i> changes to FALSE and then to TRUE.

TestABit and TestABitN

TestABit: Outputs the value of the specified bit in a bit string.

TestABitN: Outputs the inverse of the value of the specified bit in a bit string.

Instruction	Name	FB/FUN	Graphic expression	ST expression
TestABit	Test A Bit	FUN		Out:=TestABit (In, Pos);
TestABitN	Test A Bit NOT	FUN		Out:=TestABitN (In, Pos);

Variables

Name	Meaning	I/O	Description	Valid range	Unit	Default
In	Bit string	Input	Bit string	Depends on data type.	---	*
Pos	Bit position		Specified bit position	0 to No. of bits in <i>In</i> - 1		0
Out	Bit value	Output	TestABit Value of specified bit TestABitN Inverse of value of specified bit	Depends on data type.	---	---

* If you omit the input parameter, the default value is not applied. A building error will occur.

	Boolean	Bit strings				Integers							Real numbers		Times, durations, dates, and text strings					
	BOOL	BYTE	WORD	DWORD	LWORD	USINT	UINT	UDINT	ULINT	SINT	INT	DINT	LINT	REAL	LREAL	TIME	DATE	TOD	DT	STRING
In		OK	OK	OK	OK															
Pos						OK														
Out	OK																			

Function

● TestABit

The TestABit instruction assigns the value of the bit at bit position *Pos* in the bit string *In* to the bit value *Out* when *EN* is TRUE.

When *EN* is FALSE, the value of *Out* is FALSE.

● TestABitN

The TestABitN instruction assigns the inverse of the value of the bit at bit position *Pos* in the bit string *In* to the bit value *Out* when *EN* is TRUE.

When *EN* is FALSE, the value of *Out* is FALSE.

The following example shows the TestABit instruction when *Pos* is USINT#3.

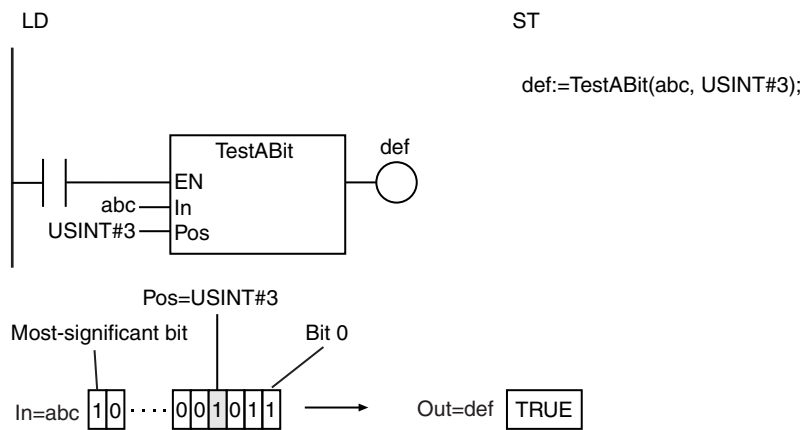

Precautions for Correct Use

- If this instruction is used in a ladder diagram, the value of *Out* changes to FALSE if an error occurs in the previous instruction on the rung.
- An error occurs in the following case. *Out* will be FALSE.
 - The value of *Pos* is greater than No. of bits in *In* - 1.

Sequence Output Instructions

Instruction	Name	Page
RS	Reset-Priority Keep	2-50
SR	Set-Priority Keep	2-53
Set and Reset	Set/Reset	2-56
SetBits and ResetBits	Set Bits/Reset Bits	2-59
SetABit and ResetABit	Set A Bit/Reset A Bit	2-61
OutABit	Output A Bit	2-63

RS

The RS instruction retains the value of a BOOL variable. It gives priority to the *Reset* input if both the *Set* input and *Reset* input are TRUE.

Instruction	Name	FB/FUN	Graphic expression	ST expression
RS	Reset-Priority Keep	FB		RS_instance(Set, Reset1, Q1);

Variables

Name	Meaning	I/O	Description	Valid range	Unit	Default
Set*	Set	Input	Set input	Depends on data type.	---	0
Reset1*	Reset		Reset input			
Q1	Keep	Output	Keep output	Depends on data type.	---	---

* On Sysmac Studio version 1.03, you can use “S” instead of “Set” and “R1” instead of “Reset1” to more clearly show the correspondence between the variables and the parameter names in ST expressions. For example, you can use the following notation: *RS_instance(S:=A, R1:=B, Q1=>abc);*.

	Boolean	Bit strings					Integers							Real numbers	Times, durations, dates, and text strings					
	BOOL	BYTE	WORD	DWORD	LWORD	USINT	UINT	UDINT	ULINT	SINT	INT	DINT	LINT	REAL	LREAL	TIME	DATE	TOD	DT	STRING
Set	OK																			
Reset1	OK																			
Q1	OK																			

Function

The RS instruction forms a self-holding output that gives priority to resetting. The following table shows the relationship between the inputs and outputs.

Value of <i>Set</i>	Value of <i>Reset1</i>	Value of <i>Q1</i>
TRUE	TRUE	FALSE
TRUE	FALSE	TRUE
FALSE	TRUE	FALSE
FALSE	FALSE	Not changed.

The following figure shows a programming example and timing chart.

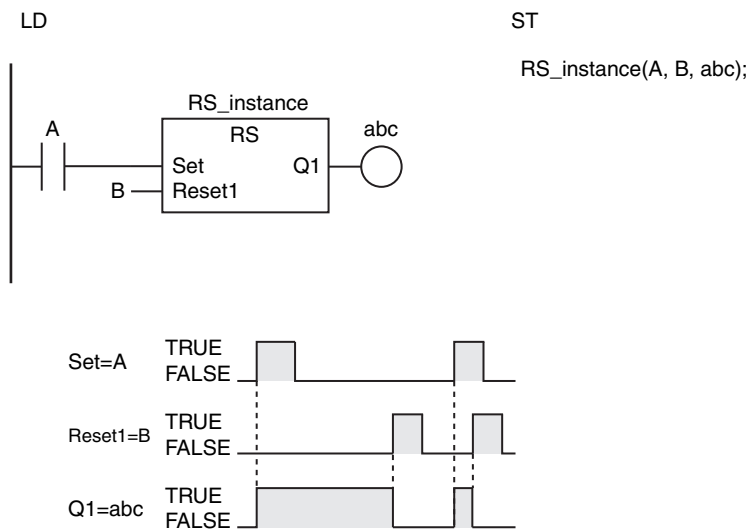

Additional Information

- The RS instruction behaves like the following self-holding rung.

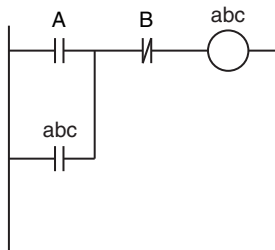

- However, if the RS instruction is in a master control region and the master control region is reset, the behavior will not be the same as the above self-holding rung.

Instruction/rung	Value of <i>B</i>	Value of <i>abc</i>
RS instruction	TRUE	Not changed.
	FALSE	FALSE
Self-holding rung	TRUE	FALSE
	FALSE	FALSE

Precautions for Correct Use

- Never use an NC bit directly from an external device for the *Reset1* input. The internal power supply in the Controller will not turn OFF immediately when the AC power is interrupted (even for momentary interruptions), and the input from the Input Unit may change to ON first. This could cause the *Reset1* input to change to TRUE.
- If this instruction is used in a ladder diagram, the value of *Q1* is retained if an error occurs in the previous instruction on the rung.
- If this instruction is not executed due to the execution of a jump instruction (e.g., the JMP instruction), *Q1* retains the value from the last execution.
- If this instruction is in a master control region and the master control region is reset, the operation is as follows:
 - If the value of *Reset1* is TRUE, the value of *Q1* is retained. If the value of *Reset1* is FALSE, the value of *Q1* changes to FALSE.
 - FALSE is input to the instruction that is connected to *Q1* even if the value of *Q1* is TRUE.

- Even if you connect a parameter with a Retain attribute to *Q1*, the value will not be retained when the power is interrupted. After the power supply is restored, the value of *Q1* will be FALSE when the operating mode is changed to RUN mode and the instruction is executed. If the self-holding rung given in *Additional Information* is used, the value is retained even after the power supply is restored.

SR

The SR instruction retains the value of a BOOL variable. It gives priority to the *Set* input if both the *Set* input and *Reset* input are TRUE.

Instruction	Name	FB/FUN	Graphic expression	ST expression
SR	Set-Priority Keep	FB		SR_instance(Set1, Reset, Q1);

Variables

Name	Meaning	I/O	Description	Valid range	Unit	Default
Set1*	Set	Input	Set input	Depends on data type.	---	0
Reset	Reset		Reset input			
Q1	Keep	Output	Keep output	Depends on data type.	---	---

* On Sysmac Studio version 1.03, you can use "S1" instead of "Set1" and "R" instead of "Reset" to more clearly show the correspondence between the variables and the parameter names in ST expressions. For example, you can use the following notation: *SR_instance(S1:=A, R:=B, Q1=>abc);*.

	Boolean	Bit strings				Integers							Real numbers		Times, durations, dates, and text strings					
	BOOL	BYTE	WORD	DWORD	LWORD	USINT	UINT	UDINT	ULINT	SINT	INT	DINT	LINT	REAL	LREAL	TIME	DATE	TOD	DT	STRING
Set1	OK																			
Reset	OK																			
Q1	OK																			

Function

The SR instruction forms a self-holding output that gives priority to setting. The following table shows the relationship between the inputs and outputs.

Value of <i>Set1</i>	Value of <i>Reset</i>	Value of <i>Q1</i>
TRUE	TRUE	TRUE
TRUE	FALSE	TRUE
FALSE	TRUE	FALSE
FALSE	FALSE	Not changed.

The following figure shows a programming example and timing chart.

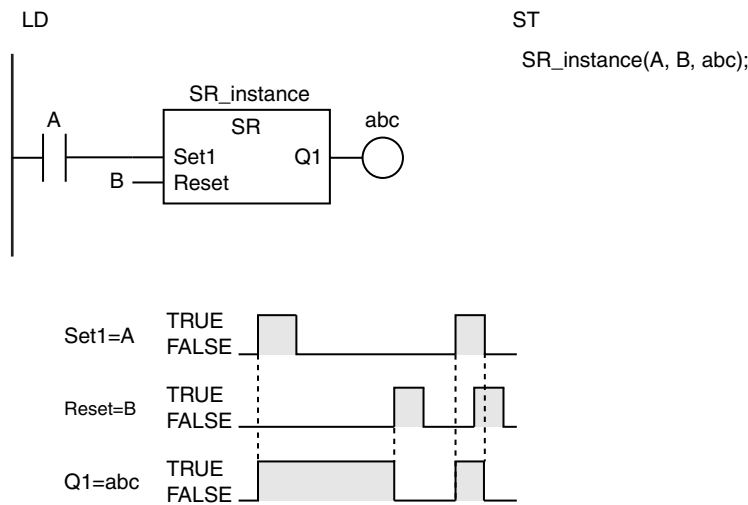

Additional Information

- The SR instruction behaves like the following self-holding rung.

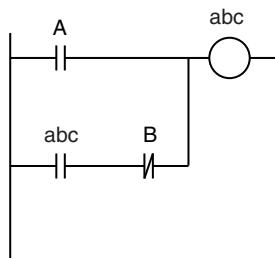

- However, if the SR instruction is in a master control region and the master control region is reset, the behavior will not be the same as the above self-holding rung.

Instruction/rung	Value of <i>B</i>	Value of <i>abc</i>
SR instruction	TRUE	Not changed.
	FALSE	FALSE
Self-holding rung	TRUE	FALSE
	FALSE	

Precautions for Correct Use

- Never use an NC bit directly from an external device for the *Reset* input. The internal power supply in the Controller will not turn OFF immediately when the AC power is interrupted (even for momentary interruptions), and the input from the Input Unit may change to ON first. This could cause the *Reset* input to change to TRUE.
- If this instruction is used in a ladder diagram, the value of *Q1* is retained if an error occurs in the previous instruction on the rung.
- If this instruction is not executed due to the execution of a jump instruction (e.g., the JMP instruction), *Q1* retains the value from the last execution.
- If this instruction is in a master control region and the master control region is reset, the operation is as follows:
 - If the value of *Reset* is TRUE, the value of *Q1* is retained. If the value of *Reset* is FALSE, the value of *Q1* changes to FALSE.
 - FALSE is input to the instruction that is connected to *Q1* even if the value of *Q1* is TRUE.

- Even if you connect a parameter with a Retain attribute to *Q1*, the value will not be retained when the power is interrupted. After the power supply is restored, the value of *Q1* will be FALSE when the operating mode is changed to RUN mode and the instruction is executed. If the self-holding rung given in *Additional Information* is used, the value is retained even after the power supply is restored.

Set and Reset

Set: Changes a BOOL variable to TRUE.

Reset: Changes a BOOL variable to FALSE.

Instruction	Name	FB/FUN	Graphic expression	ST expression
Set	Set	---		None
Reset	Reset	---		None

Variables

Name	Meaning	I/O	Description	Valid range	Unit	Default
Out	Output	Output	Output	Depends on data type.	---	---

	Boolean	Bit strings					Integers							Real numbers	Times, durations, dates, and text strings					
	BOOL	BYTE	WORD	DWORD	LWORD	USINT	UINT	UDINT	ULINT	SINT	INT	DINT	LINT	REAL	LREAL	TIME	DATE	TOD	DT	STRING
Out	OK																			

Function

● Set

The Set instruction changes *Out* to TRUE if the input is TRUE. If *Out* is TRUE, the Set instruction will not change it to FALSE even if the input changes to FALSE. Use the Reset instruction to change *Out* to FALSE.

● Reset

The Reset instruction changes *Out* to FALSE if the input is TRUE. If *Out* is FALSE, the Reset instruction will not change it to TRUE even if the input changes to FALSE. Use the Set instruction to change *Out* to TRUE.

The operation is as shown below if you do not specify upward or downward differentiation.

Instruction	Input	Output value
Set	TRUE	TRUE
	FALSE	Not changed.
Reset	TRUE	FALSE
	FALSE	Not changed.

If you specify upward or downward differentiation, the operation depends on the following: the value of the input for the last execution and the current value of the input. This is shown below.

Instruction	Differentiation specification	Value of input at last execution and current value	Output value
Set	Upward differentiation	FALSE at the last execution → Currently TRUE	TRUE
		Other than the above.	Not changed.
	Downward differentiation	TRUE at the last execution → Currently FALSE	TRUE
		Other than the above.	Not changed.
Reset	Upward differentiation	FALSE at the last execution → Currently TRUE	FALSE
		Other than the above.	Not changed.
	Downward differentiation	TRUE at the last execution → Currently FALSE	FALSE
		Other than the above.	Not changed.

The following figure shows a programming example and timing chart.

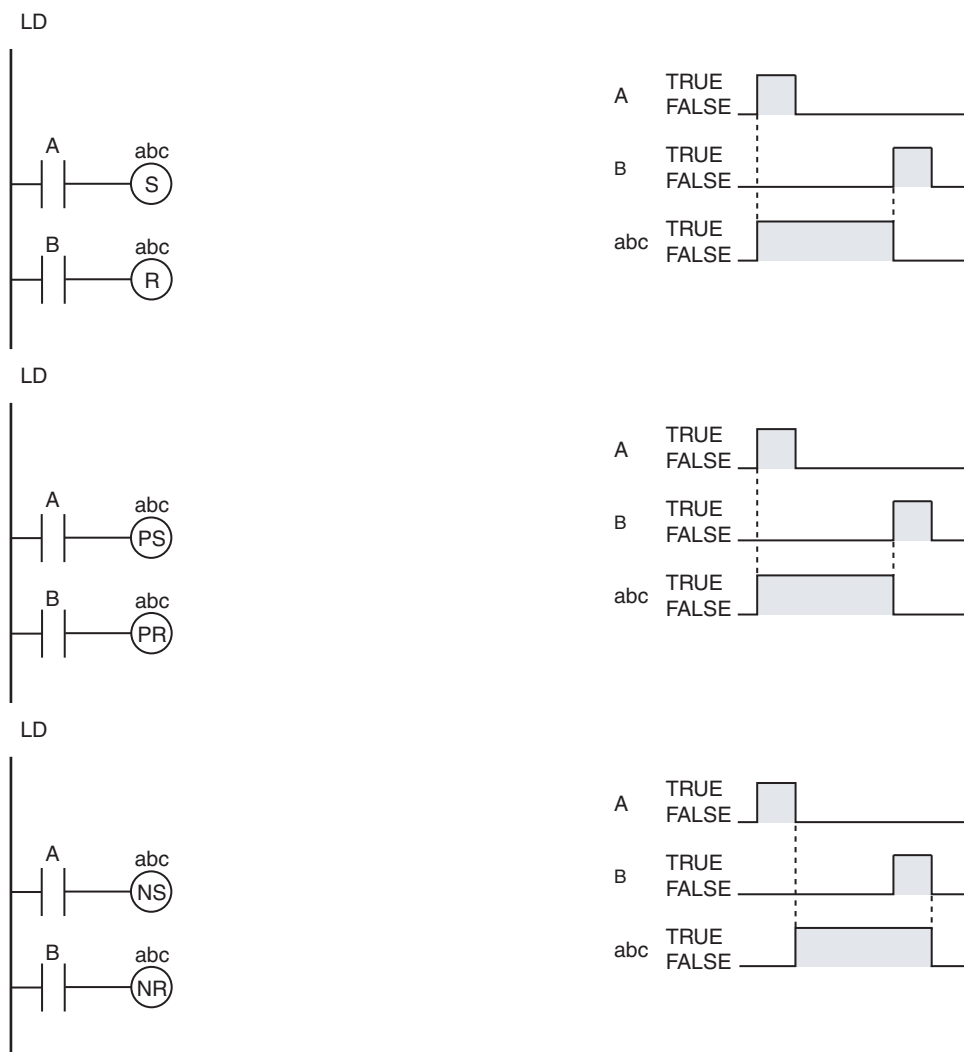

Additional Information

Differences between the Set and Reset Instructions and the Out Instruction

- The Set and Reset instructions operate only when the input value changes to TRUE. They do not operate when the input value is FALSE. When the input value is FALSE, the output does not change.
- The Out instruction changes the specified variable to TRUE when the result from the previous instruction is TRUE and to FALSE when the result from the previous instruction is FALSE. It operates both when the input is TRUE and when it is FALSE.

Differences between the Set and Reset Instructions and the SR and RS Instructions

- The SR and RS instructions require that the *Set* input and *Reset* input are in the same place in the program. You can place the Set and Reset instructions in different places.

Precautions for Correct Use

- If this instruction is in a master control region and the master control region is reset, the value of *Out* is retained.
- If this instruction is not executed due to the execution of a jump instruction (e.g., the JMP instruction), the value of *Out* is retained.
- These instructions will not change the value of *Out* if you specify upward differentiation and the input is TRUE immediately after the power turns ON. The input must first change to FALSE and then to TRUE before the value of *Out* changes.
- These instructions will change the value of *Out* if you do not specify upward differentiation and the input is TRUE immediately after the power turns ON. In this case it is not necessary for the input to change to FALSE first.

SetBits and ResetBits

SetBits: Changes consecutive bits in bit string data to TRUE.

ResetBits: Changes consecutive bits in bit string data to FALSE.

Instruction	Name	FB/FUN	Graphic expression	ST expression
SetBits	Set Bits	FUN		SetBits(InOut, Pos, Size);
ResetBits	Reset Bits	FUN		ResetBits(InOut, Pos, Size);

Variables

Name	Meaning	I/O	Description	Valid range	Unit	Default
InOut	Bit string	In-out	Bit string	Depends on data type.	---	---
Pos	Bit position	Input	Specified bit position	0 to No. of bits in <i>InOut</i> - 1	---	0
Size	Number of bits		Number of bits	0 to No. of bits in <i>InOut</i>		1
Out	Return value	Output	Always TRUE	TRUE only	---	---

	Boolean	Bit strings				Integers							Real numbers	Times, durations, dates, and text strings						
	BOOL	BYTE	WORD	DWORD	LWORD	USINT	UINT	UDINT	ULINT	SINT	INT	DINT	LINT	REAL	LREAL	TIME	DATE	TOD	DT	STRING
InOut		OK	OK	OK	OK															
Pos						OK														
Size						OK														
Out	OK																			

Function

● SetBits

The SetBits instruction changes the value of *Size* bits from the bit position *Pos* in the bit string *InOut* to TRUE. The status of the other bits will not change.

● ResetBits

The ResetBits instruction changes the value of *Size* bits from the bit position *Pos* in the bit string *InOut* to FALSE. The status of the other bits will not change.

The following example shows the SetBits instruction when *Pos* is USINT#3 and *Size* is USINT#2.

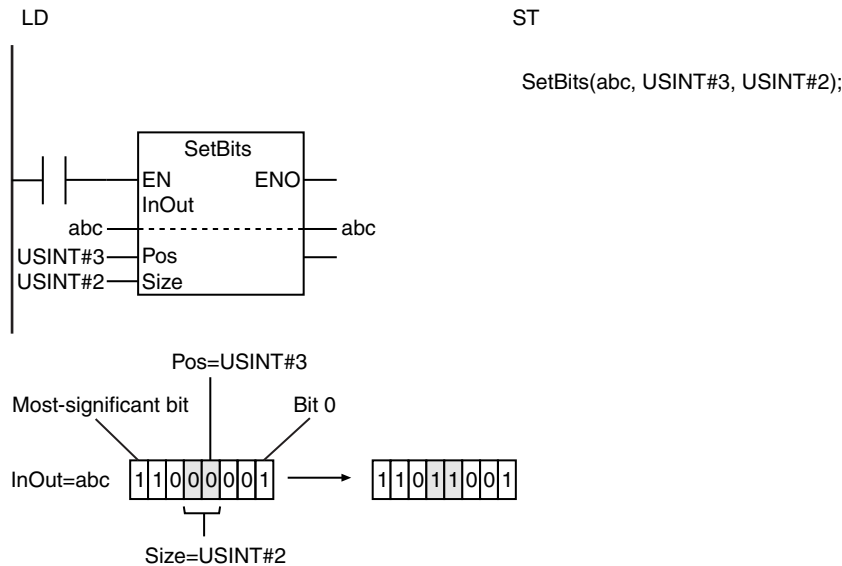

Additional Information

Use these instructions to globally set variables with AT specification in memory areas that handle data by word (e.g., the DM Area) to TRUE or FALSE.

Precautions for Correct Use

- If this instruction is in a master control region and the master control region is reset, the value of *InOut* is retained.
- If this instruction is not executed due to the execution of a jump instruction (e.g., the JMP instruction), the value of *InOut* is retained.
- The value of *InOut* does not change if the value of *Size* is 0.
- Return value *Out* is not used when the instruction is used in ST.
- An error occurs in the following cases. *ENO* will be FALSE, and *Out* and *InOut* will not change.
 - The value of *Pos* is greater than No. of bits in *InOut* – 1.
 - The value of *Size* is outside of the valid range.
 - The value of *Pos* or *Size* exceeds the number of bits in *InOut*.

SetABit and ResetABit

SetABit: Changes the specified bit in bit string data to TRUE.

ResetABit: Changes the specified bit in bit string data to FALSE.

Instruction	Name	FB/FUN	Graphic expression	ST expression
SetABit	Set A Bit	FUN	<pre> graph LR subgraph SetABit_Box [(@)SetABit] EN[EN] InOut[InOut] Pos[Pos] end Out[Out] EN --- SetABit_Box InOut --- SetABit_Box Pos --- SetABit_Box SetABit_Box --- Out </pre>	SetABit (InOut, Pos);
ResetABit	Reset A Bit	FUN	<pre> graph LR subgraph ResetABit_Box [(@)ResetABit] EN[EN] InOut[InOut] Pos[Pos] end Out[Out] EN --- ResetABit_Box InOut --- ResetABit_Box Pos --- ResetABit_Box ResetABit_Box --- Out </pre>	ResetABit (InOut, Pos);

Variables

Name	Meaning	I/O	Description	Valid range	Unit	Default
InOut	Bit string	In-out	Bit string	Depends on data type.	---	---
Pos	Bit position	Input	Specified bit position	0 to No. of bits in <i>InOut</i> - 1	---	0
Out	Return value	Output	Always TRUE	TRUE only	---	---

	Boolean	Bit strings					Integers							Real numbers		Times, durations, dates, and text strings				
	BOOL	BYTE	WORD	DWORD	LWORD	USINT	UINT	UDINT	ULINT	SINT	INT	DINT	LINT	REAL	LREAL	TIME	DATE	TOD	DT	STRING
InOut		OK	OK	OK	OK															
Pos						OK														
Out	OK																			

Function

● SetABit

The SetABit instruction changes the value of the bit at bit position *Pos* in the bit string *InOut* to TRUE.

The bits that are not specified do not change.

Even if EN changes to FALSE after execution, the *Pos* bit in *InOut* will not change.

OutABit

The OutABit instruction changes the specified bit in bit string data to TRUE or FALSE.

Instruction	Name	FB/FUN	Graphic expression	ST expression
OutABit	Output A Bit	FUN	<pre> graph LR subgraph OutABit EN[EN] InOut[InOut] Pos[Pos] BitVal[BitVal] ENO[ENO] Out[Out] end EN --- ENO InOut --- Out Pos --- Out BitVal --- Out </pre>	OutABit (InOut, Pos, BitVal);

Variables

Name	Meaning	I/O	Description	Valid range	Unit	Default
InOut	Bit string	In-out	Bit string	Depends on data type.	---	---
Pos	Bit position	Input	Specified bit position	0 to No. of bits in <i>InOut</i> - 1	---	0
BitVal	Set value		Value to set	Depends on data type.		TRUE
Out	Return value	Output	Always TRUE	TRUE only	---	---

	Boolean	Bit strings				Integers							Real numbers		Times, durations, dates, and text strings					
	BOOL	BYTE	WORD	DWORD	LWORD	USINT	UINT	UDINT	ULINT	SINT	INT	DINT	LINT	REAL	LREAL	TIME	DATE	TOD	DT	STRING
InOut		OK	OK	OK	OK															
Pos						OK														
BitVal	OK																			
Out	OK																			

Function

The OutABit instruction stores the value of set value *BitVal* at bit position *Pos* in the bit string *InOut*. Only the bit at *Pos* changes.

The following example is for when *Pos* is USINT#2 and *BitVal* is TRUE.

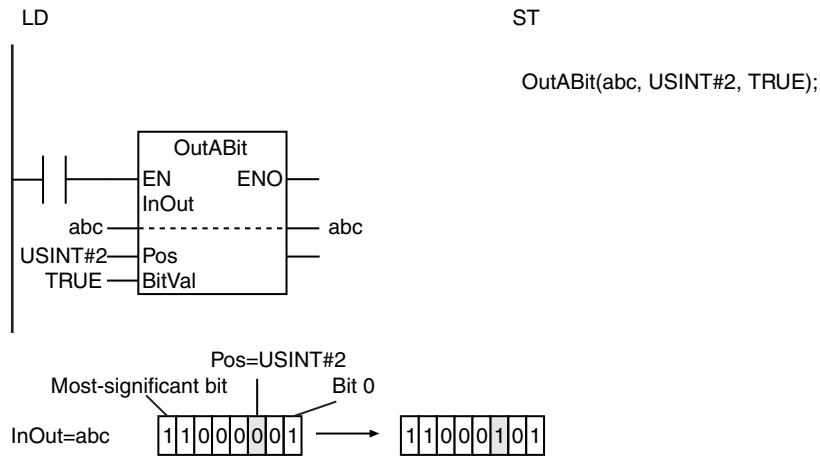

Additional Information

Differences between the SetABit and ResetABit Instructions and the OutABit Instruction

- The SetABit and ResetABit instructions change the value of the specified bit to either TRUE or FALSE.
- With the OutABit instruction, however, you can dynamically change the value to which the specified bit is set if you change the value of *BitVal*.

Precautions for Correct Use

- If this instruction is in a master control region and the master control region is reset, the value of *InOut* is retained.
- If this instruction is not executed due to the execution of a jump instruction (e.g., the JMP instruction), the value of *InOut* is retained.
- Return value *Out* is not used when the instruction is used in ST.
- An error will occur in the following case. *ENO* will be FALSE, and *Out* and *InOut* will not change.
 - The value of *Pos* is greater than No. of bits in *InOut* – 1.

Sequence Control Instructions

Instruction	Name	Page
End	End	2-66
RETURN	Return	2-67
MC and MCR	Master Control Start/ Master Control End	2-68
JMP	Jump	2-80
FOR and NEXT	Repeat Start/ Repeat End	2-82
BREAK	Break Loop	2-89

End

The End instruction ends execution of a program in the current task period.

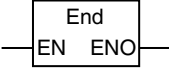
Instruction	Name	FB/FUN	Graphic expression	ST expression
End	End	FUN		None

Variables

None

Function

The End instruction ends execution of a program in the current task period.

The following figure shows a programming example. When the End instruction is executed in the example, the SR instruction that follows it is not executed.

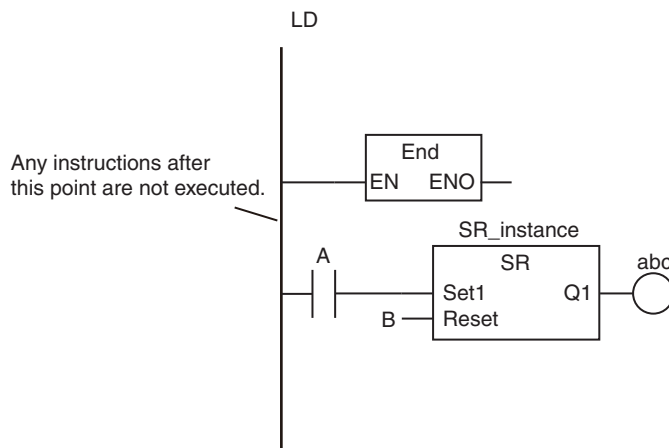

Precautions for Correct Use

- This instruction must be used only in a program.
- If this instruction is used in a function, function block, or inline ST, a building error will occur.
- You must connect this instruction to the left bus bar.

RETURN

The RETURN instruction ends a function or function block and returns processing to the calling instruction.

Instruction	Name	FB/FUN	Graphic expression	ST expression
RETURN	Return	FUN		RETURN;

Variables

None

Function

The RETURN instruction ends a function or function block and returns processing to the calling instruction.

The following figure shows a programming example. When the RETURN instruction is executed in the example, the SR instruction that follows it is not executed.

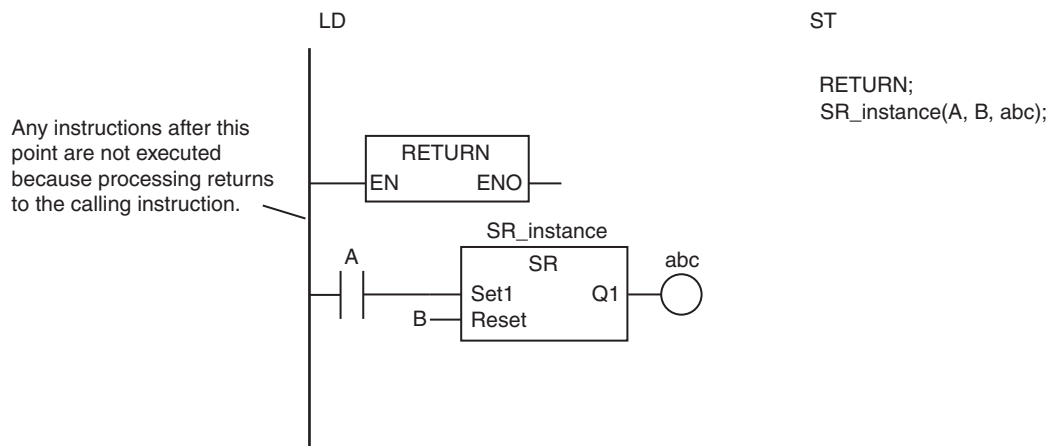

Precautions for Correct Use

- Observe the following precautions if you use this instruction in a ladder diagram.
 - Use this instruction only in functions and function blocks. If you use it in a program, a building error will occur.
 - Always connect this instruction directly to the left bus bar.
- Before you execute this instruction set the return values, output variables, and ENO value of the POU.
- If you use this instruction too often, the flow of processing will be difficult to understand. Use it with caution.

MC and MCR

MC: Marks the starting point of a master control region and resets the master control region.

MCR: Marks the end point of a master control region.

Instruction	Name	FB/FUN	Graphic expression	ST expression
MC	Master Control Start	---		None
MCR	Master Control End	---		None

Variables

Name	Meaning	I/O	Description	Valid range	Unit	Default
In (MC instruction only)	Master control input	Input	FALSE: Resets the master control region.	Depends on data type.	---	---
MCNo	Master control number		Master control number	0 to 14*		0

* The number is automatically registered by the Sysmac Studio. You do not need to set it.

	Boolean	Bit strings					Integers							Real numbers		Times, durations, dates, and text strings				
	BOOL	BYTE	WORD	DWORD	LWORD	USINT	UINT	UDINT	ULINT	SINT	INT	DINT	LINT	REAL	LREAL	TIME	DATE	TOD	DT	STRING
In (MC instruction only)	OK																			
MCNo							OK													

Function

Master control is used to stop processing or place in an equivalent status all POU's in a specified region of a program. You can use master control to easily control the execution conditions for a relatively long segment of processing.

The region in the program for which master control is applied is called the master control region. You place the MC instruction at the start of the master control region and the MCR instruction at the end. When the value of the master control input *In* changes to FALSE, the outputs for all LD instructions that are connected to the left bus bar in the master control region are forced to change to FALSE. This is called a master control reset.

When master control is reset, the POU's that follow the LD instructions, as a rule, operate as if the execution condition is FALSE. There are, however, some POU's that operate differently. This is explained later.

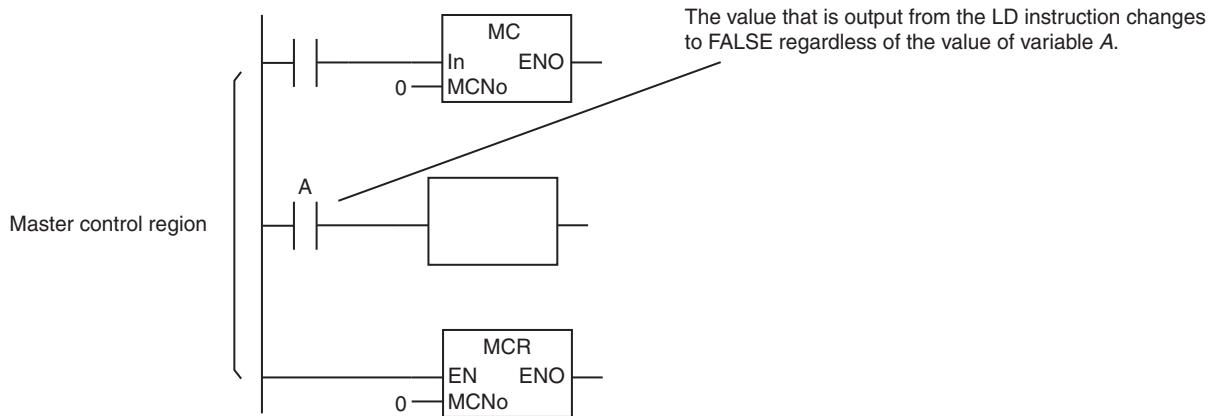

If the value of *In* is TRUE, then master control is not reset. The POUs in the master control region operate normally.

POU Operation during a Master Control Reset

The operation of the POUs when master control is reset depends on the POU as described in the following table.

POU	Operation
Out and OutABit instructions	FALSE is output to the specified variable.
OutNot instruction	FALSE is output to the specified variable.
Set and Reset instructions	The output from before the master control reset is retained.
TON instruction	The instruction operates with a FALSE value for timer input <i>In</i> . That means that the timer is reset. The value of elapsed time <i>ET</i> changes to 0 and the value of timer output <i>Q</i> changes to FALSE.
TOF instruction	The instruction operates with a TRUE value for timer input <i>In</i> . That means that the timer is reset. The value of elapsed time <i>ET</i> changes to 0 and the value of timer output <i>Q</i> changes to TRUE. However, if an Out instruction is connected to <i>Q</i> , the execution condition to the Out instruction is FALSE.
TP instruction	The instruction operates with a FALSE value for timer input <i>In</i> . That means that the timer is reset. Timing active: The value of elapsed time <i>ET</i> is incremented to the end and then returns to 0. The value of timer output <i>Q</i> is TRUE until the end of timing, and then it changes to FALSE. Timing not active: The value of <i>ET</i> changes to 0 and the value of <i>Q</i> changes to FALSE. However, if an Out instruction is connected to <i>Q</i> , the execution condition to the Out instruction is FALSE even while timing is active.
AccumulationTimer instruction	The instruction operates with a FALSE value for timer input <i>In</i> . That means that the timer stops. The values of elapsed time <i>ET</i> and timer output <i>Q</i> are retained. However, if an Out instruction is connected to <i>Q</i> , the execution condition to the Out instruction is FALSE even if the value of <i>Q</i> is TRUE. However, reset <i>Reset</i> is enabled.
Timer instructions	The instruction operates with a FALSE value for timer input <i>In</i> . That means that the timer is reset. Remaining time <i>ET</i> is set to the value of set time <i>PT</i> , and the value of timer output <i>Q</i> changes to FALSE.
CTU, CTD, and CTUD instructions	These instructions are not executed. If the instruction was in operation before the master control reset, the count value from before the reset is held. If an Out instruction is connected to the Counter Completion Flag, <i>Q</i> , the execution condition to the Out instruction is FALSE.
JMP instruction	This instruction is not executed.

POU	Operation
FOR and NEXT instructions	These instructions are not executed.
BREAK instruction	This instruction is not executed.
Function blocks that are executed over more than one task period (i.e., instructions with <i>Done</i> , <i>Busy</i> , and <i>Error</i> output variables)	The power flow from the left bus bar changes to FALSE. If the instruction was operating before the master control reset, execution of the instruction is continued until processing is completed. <i>Busy</i> , <i>Done</i> , and <i>Error</i> outputs will be made, but FALSE will always be output if the next instruction is an output instruction. If a variable is directly connected to <i>Busy</i> , <i>Done</i> , or <i>Error</i> , the proper value for the instruction specifications will be assigned to that variable. You can also get the value of <i>Busy</i> , <i>Done</i> , or <i>Error</i> in the form <i>instance_name.output_variable</i> .
Other functions	These are not executed.
Other function blocks	The power flow from the left bus bar changes to FALSE.

The operation of some typical instructions is described below.

● **Out**

FALSE is output while the master control is reset.

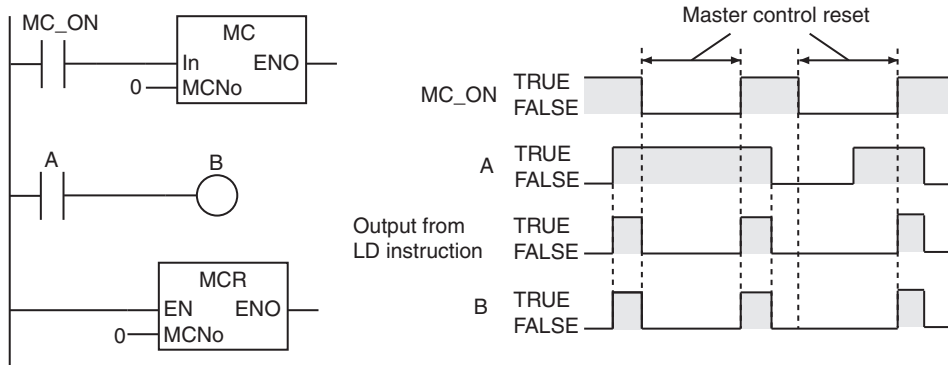

● **OutNot**

FALSE is output while the master control is reset. Caution is required because this operation of the OutNot instruction is different from when the output of the previous LD instruction is FALSE.

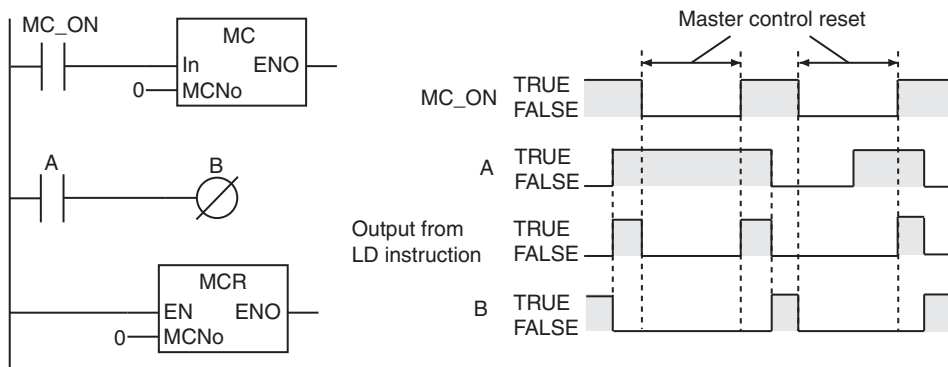

● **Set and Reset**

The previous value of the output is retained while the master control is reset.

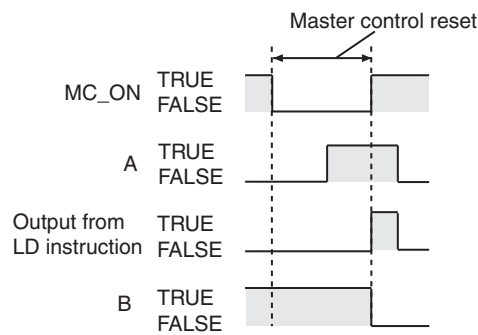
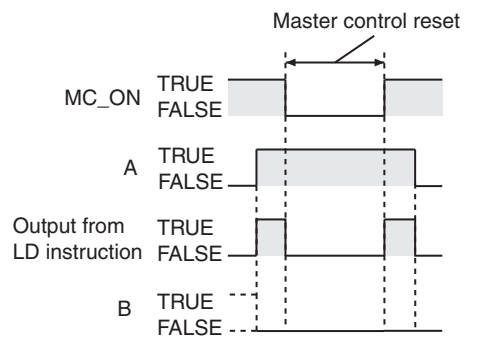
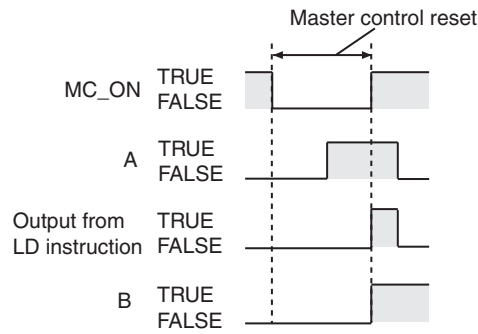
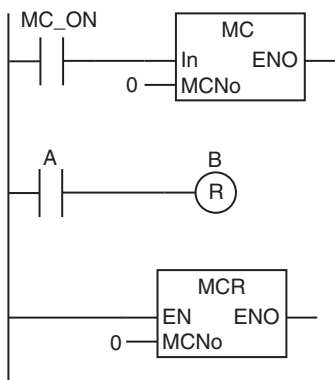
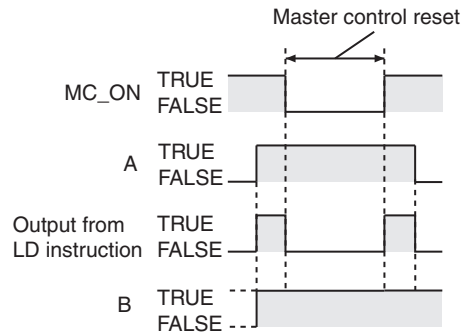
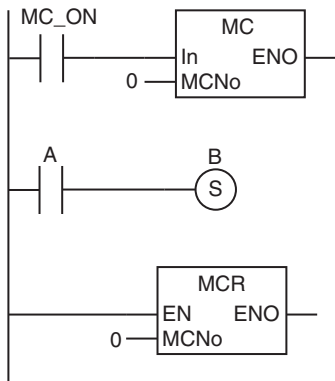

● **CTU, CTD, and CTUD**

The previous counter value is retained while the master control is reset. When the master control reset is cleared, counting continues from the counter value that was retained.

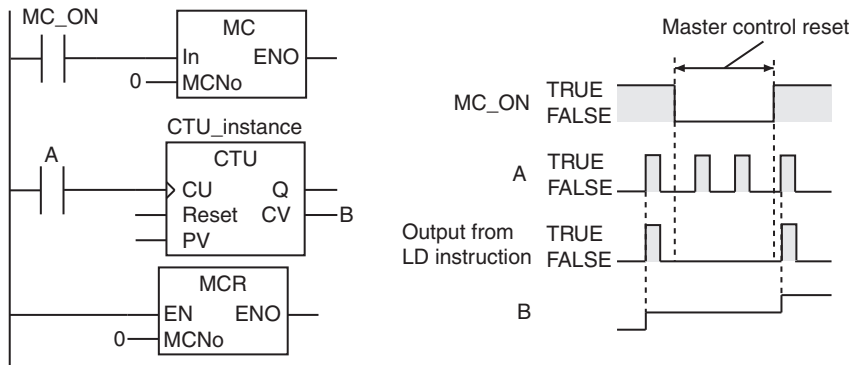

Operation of POUs with Input Upward Differentiation or Input Downward Differentiation

The POUs that are given in the following table have upward or downward differentiation specifications.

Differentiation	Instructions
Input upward differentiation	<ul style="list-style-type: none"> LD, LDN, AND, ANDN, OR, ORN, and OUT with upward differentiation specifications R_TRIG (Up) Functions with an @ input upward differentiation option Functions blocks (e.g., counter instructions) with input upward differentiation specifications
Input downward differentiation	<ul style="list-style-type: none"> LD, LDN, AND, ANDN, OR, ORN, and OUT with downward differentiation specifications F_TRIG (Down)

When the master control is reset or the reset is cleared, the execution conditions for these POUs change. That means that the upward or downward differentiation conditions for these POUs may be met. If the upward or downward differentiation conditions are met, then the instructions are executed accordingly. The operation of some typical instructions is described below.

● **R_TRIG (Up)**

When the master control is reset, the execution condition changes to FALSE. If the execution condition is TRUE when the master control reset is cleared, the input upward differentiation condition is met and the instruction operates accordingly.

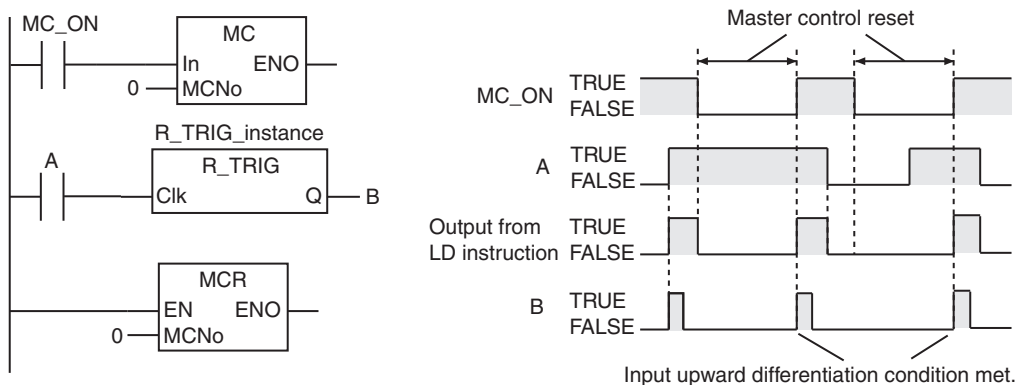

● **F_TRIG (Down)**

When the master control is reset, the execution condition changes to FALSE. If the previous execution condition was TRUE, then the input downward differentiation condition is met. However, the value of the output from the F_TRIG (Down) instruction during the master control reset is forced to change to FALSE, so the output value changes to FALSE.

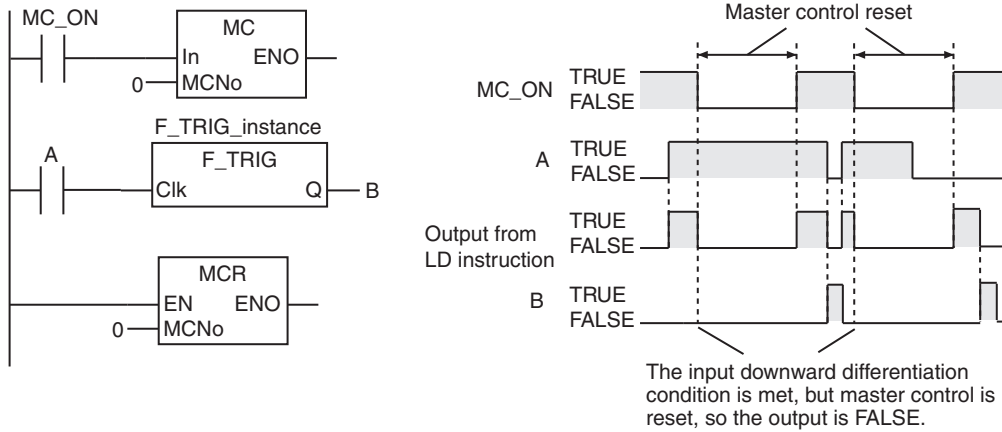

● **Set and Reset with Input Upward Differentiation Specification**

The previous value of the output is retained while the master control is reset. When the master control reset is cleared, the execution condition changes to TRUE and the instruction operates.

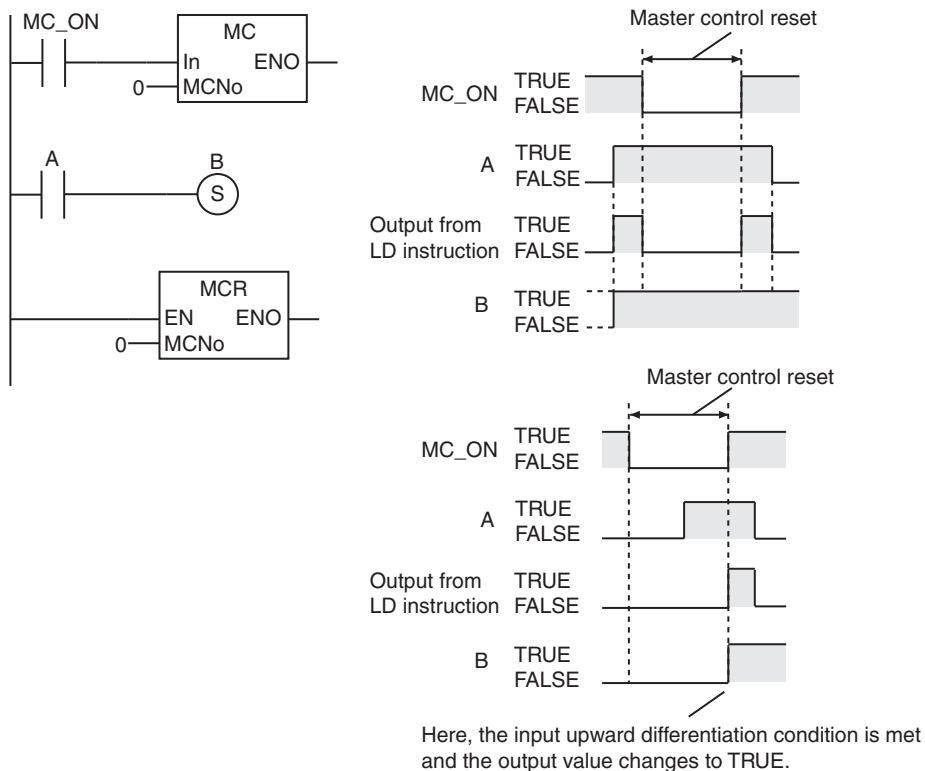

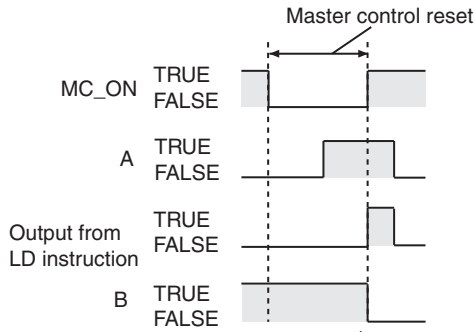
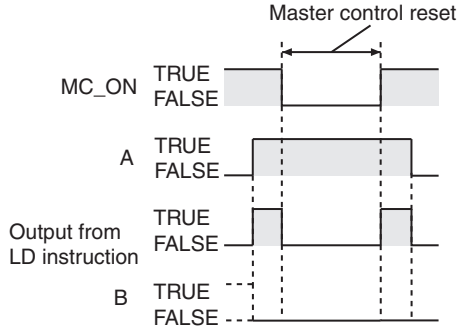
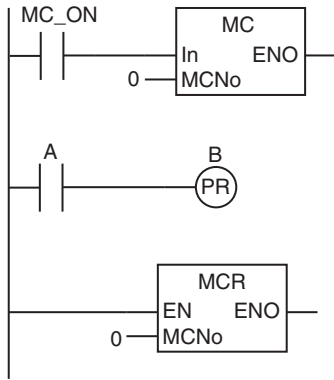

Here, the input upward differentiation condition is met and the output value changes to FALSE.

● Set and Reset with Input Downward Differentiation Specification

When the master control is reset, the execution condition changes to FALSE. If the previous execution condition was TRUE, then the input downward differentiation condition is met. However, during the master control reset, the previous output value is retained, so as a result the value of the output is retained.

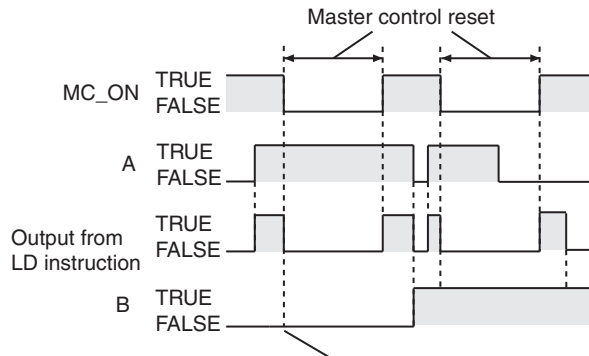
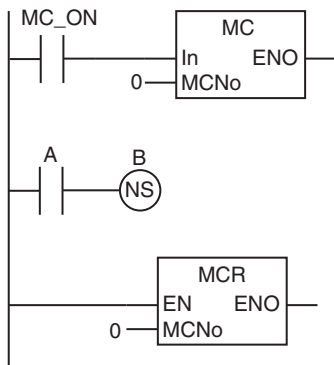

The input downward differentiation condition is met, but master control is reset, so the output is retained.

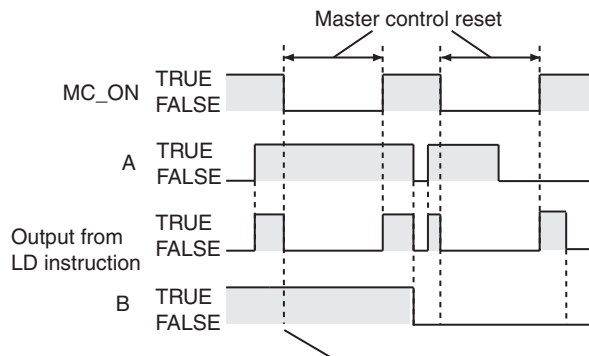
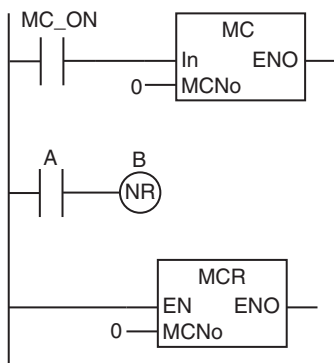

The input downward differentiation condition is met, but master control is reset, so the output is retained.

● **CTU, CTD, and CTUD**

When the master control is reset, the value of the counter input changes to FALSE. If the value of the counter input is TRUE when the master control reset is cleared, the input upward differentiation condition is met and the instruction counts.

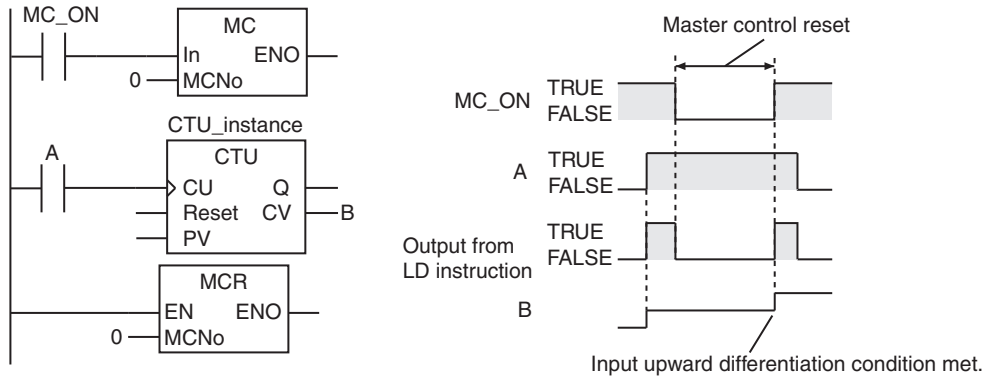

Always use the MC and MCR instructions as a pair in the same POU. The same value is used for master control number *MCNo* for both of the paired MC and MCR instructions. The user does not set the value of *MCNo*. It is automatically registered by the Sysmac Studio.

The MC and MCR instructions can be nested to up to 15 levels.

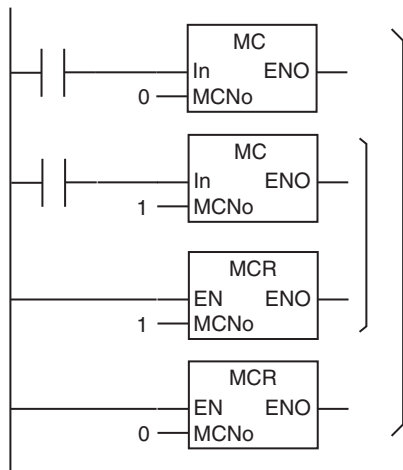

The following figure shows a programming example.

If the value of bit A is FALSE, the master control region is reset. While the master control region is in a reset state, the TON and MOVE instructions are not executed. Also the Out instruction and OutNot instruction will output FALSE to bits D and E.

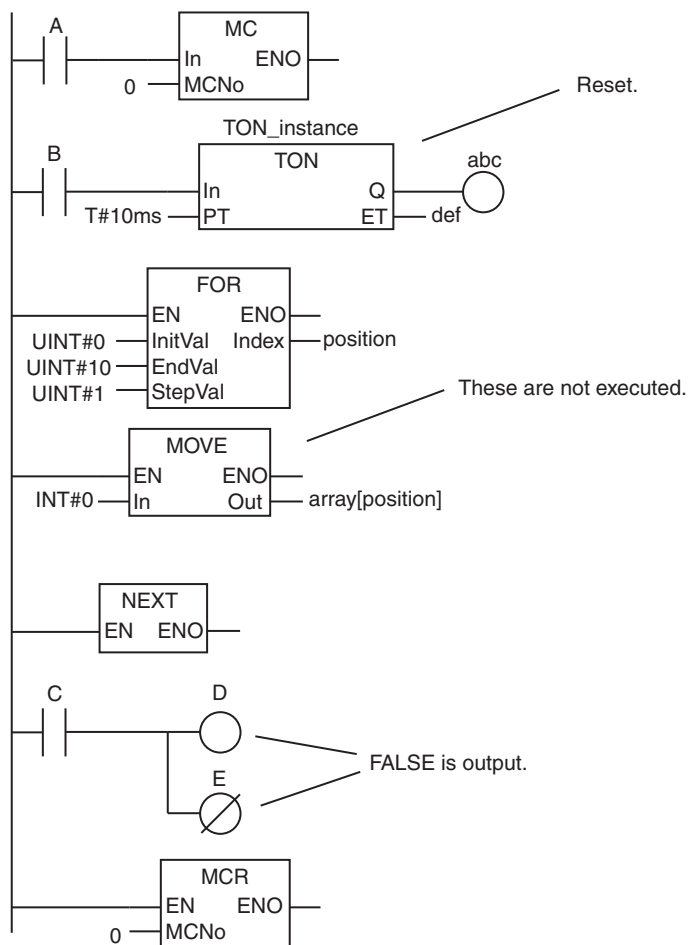

Precautions for Correct Use

- These instructions must be used in a ladder diagram. They cannot be used in ST. They also cannot be used in inline ST in a ladder diagram.
- Always connect *In* directly to the left bus bar. You cannot pass a variable or constant to *In*.
- Always use the MC and MCR instructions as a pair in the same POU.
- Always place the MCR instruction after the MC instruction.
- Do not nest the MC and MCR instructions to more than 15 levels.
- If there is inline ST in the master control region, the inline ST is not executed when the master control region is reset.

- If you use the MC and MCR instructions and the JMP instruction together, the operation is as follows:
 - The following figure shows an MC-MCR pair inside a JMP-Label pair. Here, the jump is executed regardless of the value of *In*.

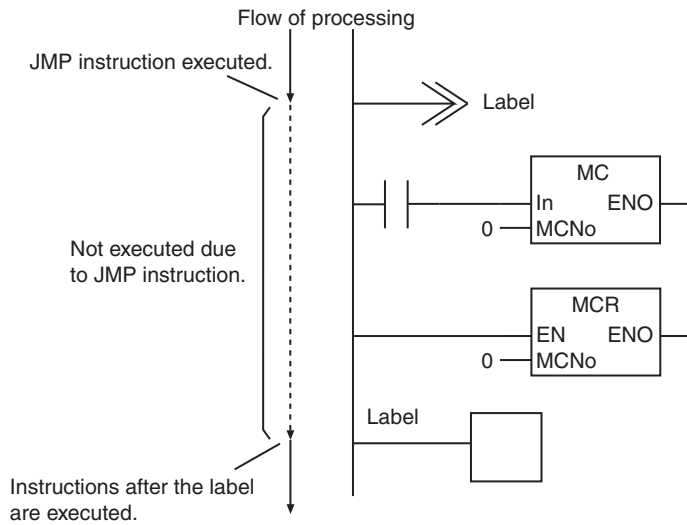

- The following figure shows a JMP-Label pair inside an MC-MCR pair. Here, operation is as given in the following table.

Value of <i>In</i>	Operation
TRUE	Master control region is not reset. The jump is made.
FALSE	Master control region is reset. The jump is not made.

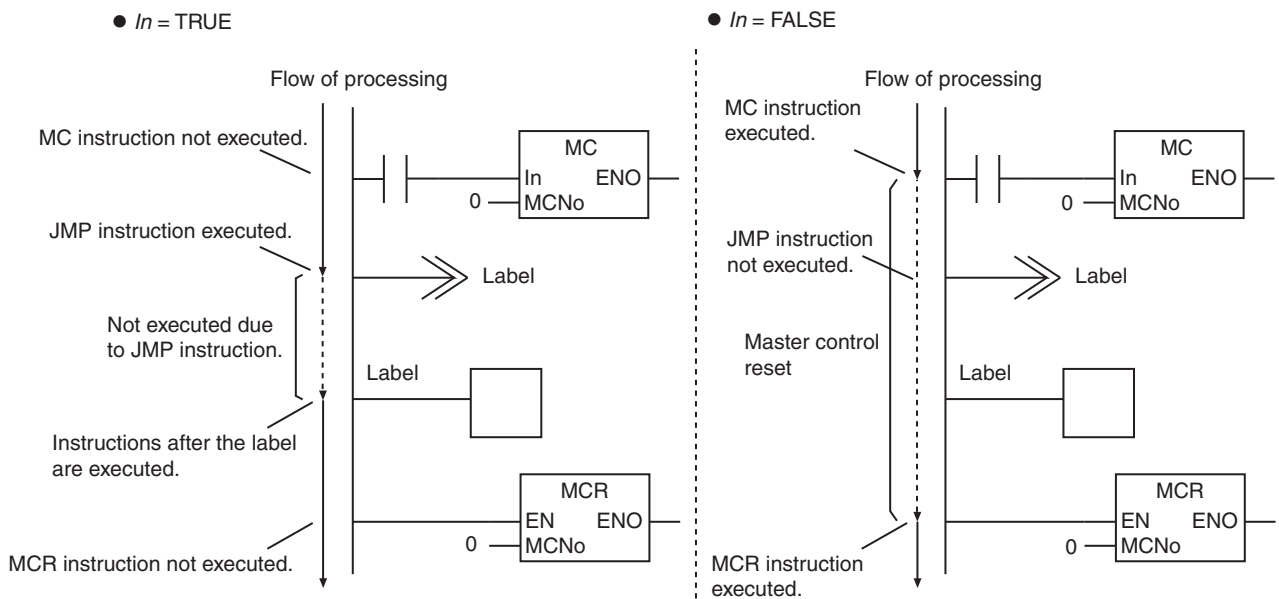

- The instructions are in the following order in the following figure: JMP instruction, MC instruction, Label, and MCR instruction. First, the jump is made. As a result, the MC instruction is not executed. Therefore, the instructions after the Label instruction are executed. If the value of *In* is FALSE, the MCR instruction is executed, but nothing changes.

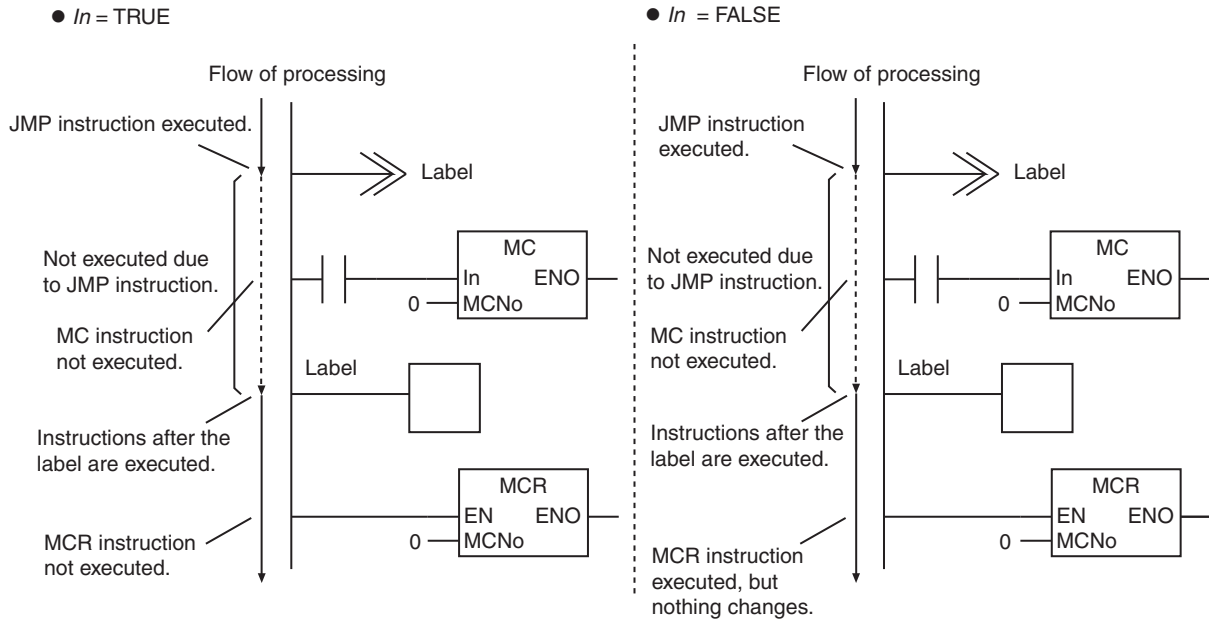

- The instructions are in the following order in the following figure: MC instruction, JMP instruction, MCR instruction, and Label. Here, operation is as given in the following table.

Value of <i>In</i>	Operation
TRUE	Master control region is not reset. The jump is made.
FALSE	Master control region is reset. The jump is not made.

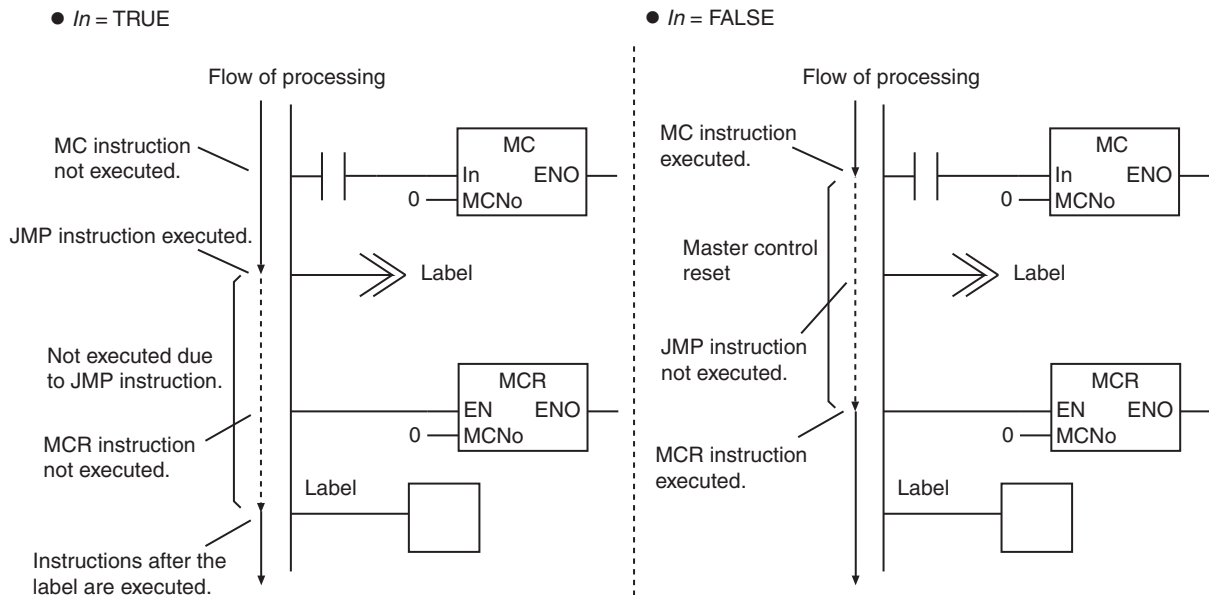

- If you use the MC and MCR instructions and the FOR and NEXT instructions together, the operation is as follows:
 - The following figure shows an MC-MCR pair inside a FOR-NEXT pair. Here, operation is as given in the following table.

Value of In	Operation
TRUE	Master control region is not reset. The FOR loop is executed.
FALSE	Master control region is reset. The FOR loop is executed, but the instructions between the MC and MCR instructions are not executed.

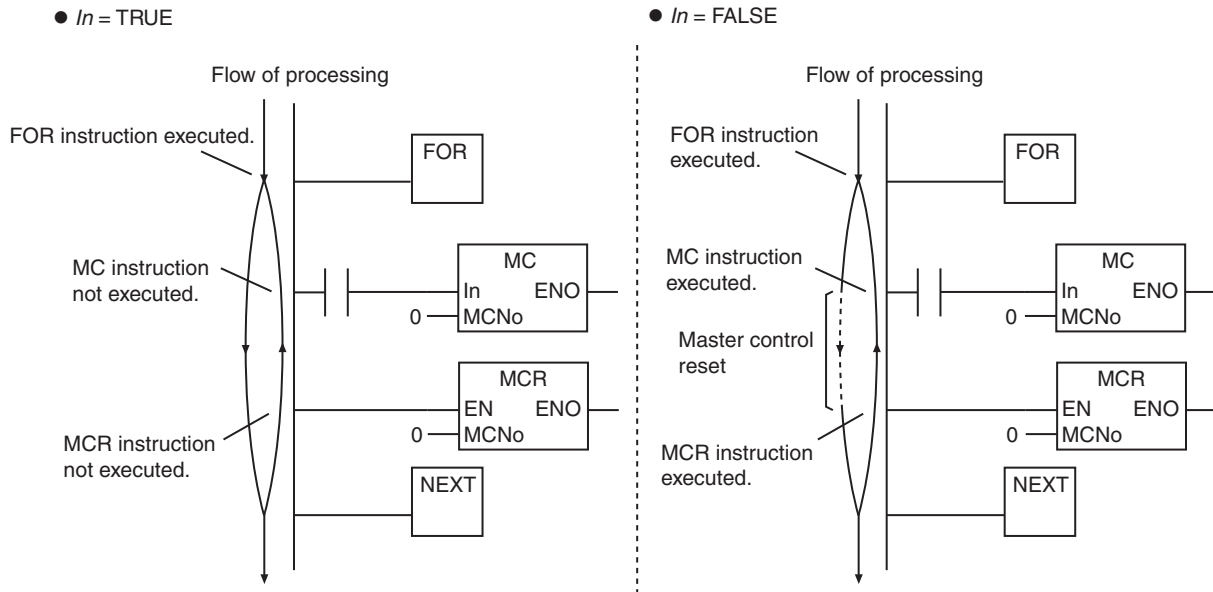

- The following figure shows a FOR-NEXT pair inside an MC-MCR pair. Here, operation is as given in the following table.

Value of In	Operation
TRUE	Master control region is not reset. The FOR loop is executed.
FALSE	Master control region is reset. The FOR loop is not executed.

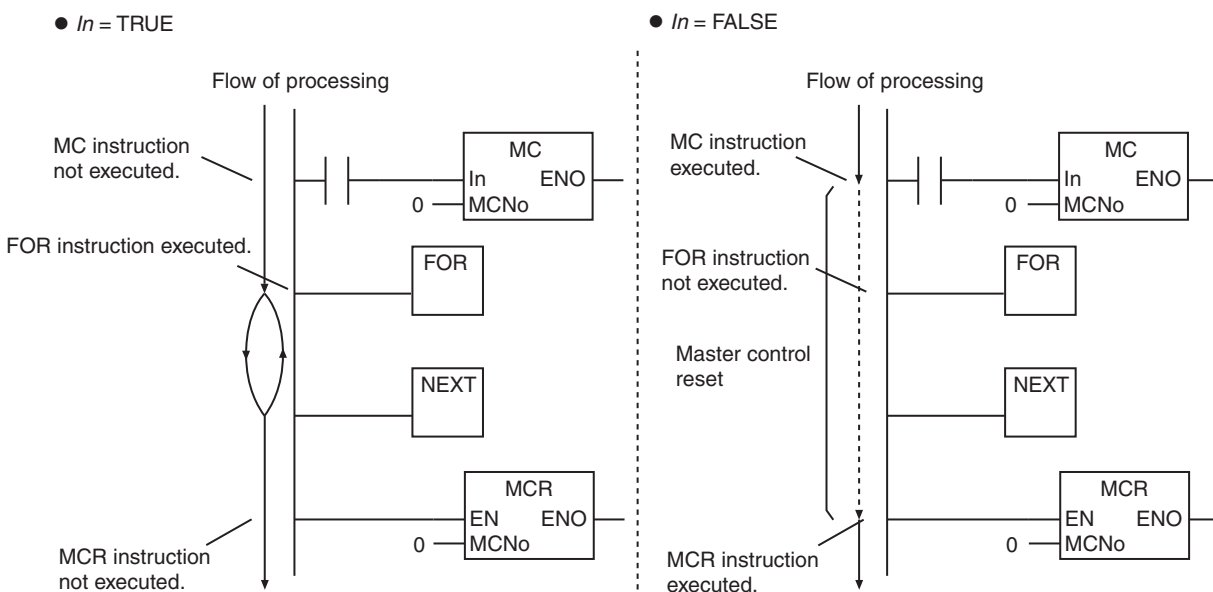

- A building error occurs if the FOR, NEXT, MC, and MCR instructions are used in either of the following orders.

FOR, MC, NEXT, MCR, or MC, FOR, MCR, NEXT

JMP

The JMP instruction moves processing to the specified jump destination.

Instruction	Name	FB/FUN	Graphic expression	ST expression
JMP	Jump	FUN	 Label	None

Variables

None

Function

When the execution condition is TRUE, the JMP instruction moves processing to the jump destination specified by a Label in a ladder diagram. The label can be any text string.

The following figure shows a programming example. This example uses the text string *STEP1* as the label. When the JMP instruction is executed, processing moves to the location marked *STEP1*. In this example, the Out instruction between the JMP instruction and the Label is not executed, and the value of variable *B* is retained.

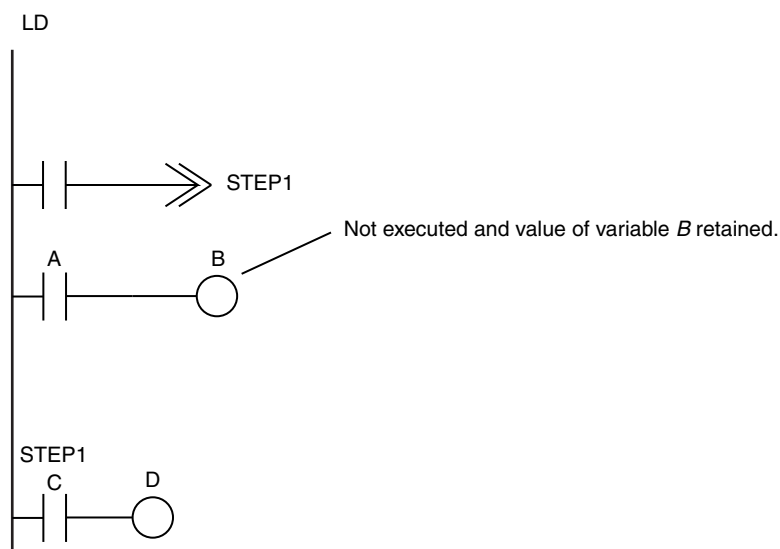

Additional Information

- You can also jump to a Label instruction above the JMP instruction in the section.
- You can use the same Label instruction as the jump destination for more than one JMP instruction.

Precautions for Correct Use

- You cannot omit labels. If you omit a label, a building error will occur.
- Place the JMP and Label instructions in the same POU and in the same section.
- Do not set the same Label instruction more than once in the same section.
- You cannot jump into a FOR-NEXT loop from outside the loop.

- The following restrictions apply to the characters that can be used as labels.

Item	Specification
Maximum number of bytes	127 bytes 127 characters when converted to ACSII 31 characters when converted to Japanese characters (including single-byte kana)
Character code	UTF-8
Applicable characters	Not case sensitive. English alphanumeric characters and other language characters. Symbols: _ (underbar) and ~ (tilde)
Prohibited text strings	<ul style="list-style-type: none"> Any text string that starts with ASCII characters 0 to 9 (character codes 16#30 to 16#39) A text string that consists of only a single _ (underbar) ASCII character Any text string that includes two or more consecutive _ (underbar) ASCII characters Any text string that starts with an _ (underbar) ASCII character Any text string that ends with an _ (underbar) ASCII character Any text string that starts with 'P_'
Prohibited characters	Blank space ! " # \$ & ' () * + , - . / : ; < = > ? @ [] ^ ` %

- Variable names cannot be used as labels.

FOR and NEXT

- FOR: Marks the starting position for repeat processing and specifies the repeat condition.
- NEXT: Marks the ending position for repeat processing.

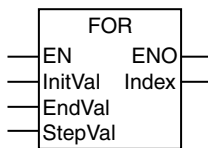
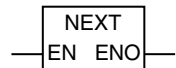
Instruction	Name	FB/FUN	Graphic expression	ST expression
FOR	Repeat Start	FUN		FOR Index:=InitVal TO EndVal BY StepVal DO expression END_FOR*; * In ST, do not use NEXT to mark the ending position of repeat processing. Use END_FOR instead.
NEXT	Repeat End	FUN		

Variables

Name	Meaning	I/O	Description	Valid range	Unit	Default
InitVal	Initial value	Input	Value to set the <i>Index</i> to when repetition is started.	Depends on data type.*1	---	*2
EndVal	End value		Value of <i>Index</i> where repetition is stopped			
StepVal	Increment		Value to add to <i>Index</i> each time processing is repeated	Depends on the data type.*3		*4
Index	Control variable	Output	Loop index	Depends on data type.	---	---

- *1 When using a ladder diagram, set *InitVal* so that it is less than *EndVal*.
- *2 If you omit an input parameter, the default value is not applied. A building error will occur.
- *3 When using a ladder diagram, 0 and negative numbers are not included. When using an ST program, 0 is not included.
- *4 If you omit the input parameter in a ladder diagram, the default value is not applied. A building error will occur. If you omit the input parameter in ST, a default value of 1 is applied.

	Boolean	Bit strings					Integers							Real numbers	Times, durations, dates, and text strings					
	BOOL	BYTE	WORD	DWORD	LWORD	USINT	UINT	UDINT	ULINT	SINT	INT	DINT	LINT	REAL	LREAL	TIME	DATE	TOD	DT	STRING
InitVal						OK	OK	OK	OK	OK	OK	OK	OK							
	An enumeration, array element or structure member can also be specified.*																			
EndVal						OK	OK	OK	OK	OK	OK	OK	OK							
	An array element or structure member can also be specified.																			
StepVal						OK	OK	OK	OK	OK	OK	OK	OK							
	An array element or structure member can also be specified.																			
Index						OK	OK	OK	OK	OK	OK	OK	OK							
	An array element or structure member can also be specified.																			

* You cannot specify enumerations in ladder diagrams.

Function

The FOR and NEXT instructions repeat the processing that you place between them. (FOR and END_FOR are used in ST.) The processing procedure for a FOR-NEXT loop is as follows:

- 1** The value of *InitVal* is set in control variable *Index*.
- 2** The values of *StepVal*, *Index*, and *EndVal* are checked to see if the conditions in the following table are met. If the conditions are met, processing moves to step 3. If the conditions are not met, repeat processing is not performed, and processing moves to the next process after the NEXT instruction (or END_FOR in ST).

Programming language	Conditions to start repeat processing
Ladder diagram	$StepVal \geq 0$ and $Index < EndVal$
ST	$StepVal \geq 0$ and $Index \leq EndVal$
	$StepVal < 0$ and $Index \geq EndVal$

- 3** The values of *Index* and *EndVal* are checked to see if the conditions in the following table are met. If the conditions are met, processing moves to step 4. If the conditions are not met, repeat processing is ended, and processing moves to the next process after the NEXT instruction (or END_FOR in ST).

Programming language	Conditions to continue repeat processing
Ladder diagram	$Index \leq EndVal$
ST	If $StepVal \geq 0$, $Index$ must be $\leq EndVal$
	If $StepVal < 0$, $Index$ must be $\geq EndVal$

- 4** The processing between the FOR instruction and the NEXT instruction (or the END_FOR instruction in ST) is executed once.
- 5** The value of *StepVal* is added to *Index*.
- 6** Processing returns to step 3.

The following example is for when *InitVal* is INT#0, *EndVal* is INT#9, and *StepVal* is INT#1. The MOVE instruction is executed 10 times and INT#0 is assigned to array variables *AryOut[0]* to *AryOut[9]*.

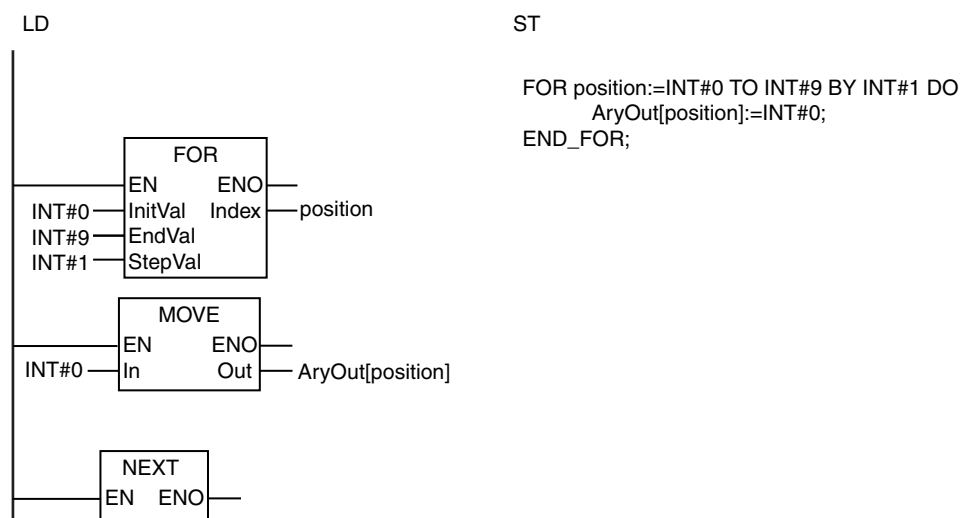

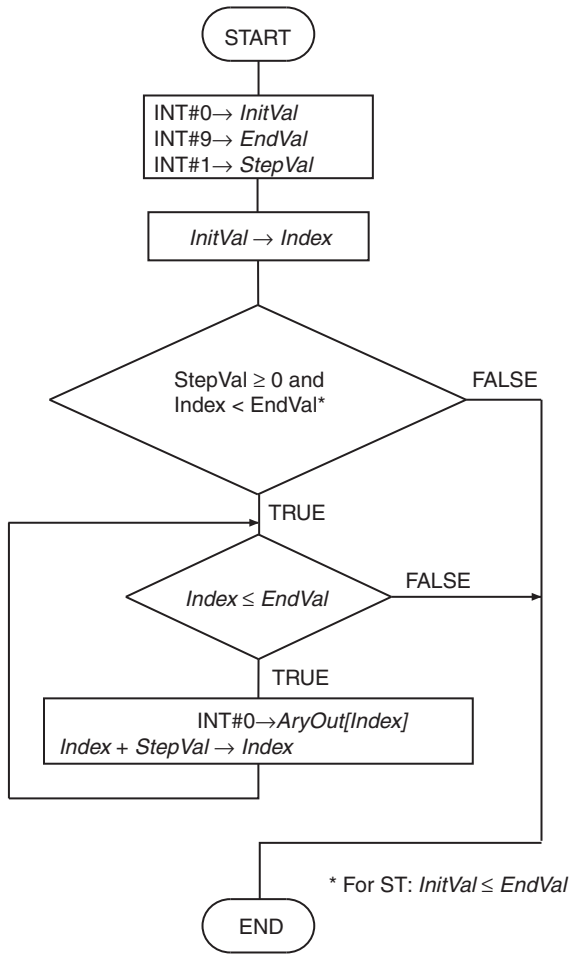

INT#0 is assigned in order to *AryOut[0]* to *AryOut[9]*.

AryOut[0]	INT#0
AryOut[1]	INT#0
AryOut[2]	INT#0
AryOut[3]	INT#0
AryOut[4]	INT#0
AryOut[5]	INT#0
AryOut[6]	INT#0
AryOut[7]	INT#0
AryOut[8]	INT#0
AryOut[9]	INT#0

ST Programming Example That Uses Expressions or Functions for Input Variables.

If you use these instructions in an ST program, you can use the following notation for the *InitVal*, *EndVal*, and *StepVal* input variables.

- An expression with an integer result
- A function that returns an integer
- A function that returns an enumerator

The following example programs a function for *EndVal* and an expression for *StepVal*.

```

A := DINT#1;
B := DINT#2;
C := REAL#9.6;
FOR i := 0 TO RoundUp(C) BY A+B DO
    DINTArray[i] := i;
END_FOR;
    
```



Version Information

Systemac Studio version 1.08 or higher is required to use expressions for *EndVal* and *StepVal*. You can use an expression for *InitVal* even with Systemac Studio version 1.07 or lower.

Additional Information

- Execute a BREAK instruction (or an EXIT instruction in ST) to cancel repeat processing. The processing between the BREAK instruction and the NEXT instruction will not be executed.
- FOR-NEXT loops (or FOR-END_FOR loops in ST) can be nested. In the following figure, the processes are performed in the following order.

Process A → Process B → Process B → Process C → Process A → Process B → Process B → Process C → Process A → Process B → Process B → Process C

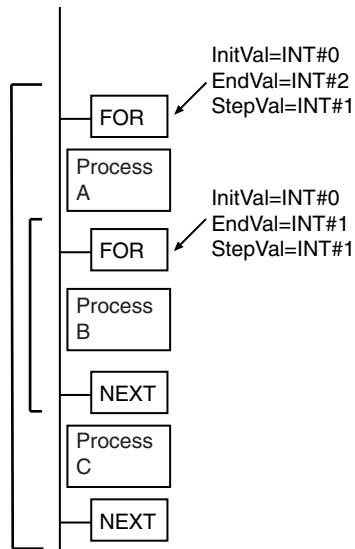

Precautions for Correct Use

- In a ladder diagram, connect the FOR and NEXT instructions directly to the left bus bar.
- Always use the FOR and NEXT instructions (FOR and END_FOR statements in ST) as a pair. A programming error will occur if there is not the same number of both instructions.
- Program the paired FOR and NEXT instructions in the same section.
- Set the condition to end repetition carefully so that you do not create an infinite loop. If an infinite loop occurs, task execution will time out.

Example: If the values that are given in the following table are used for the input parameters to the variables, the value of Index will never be greater than the value of *EndVal* because the maximum value of SINT data is 127. Therefore, an infinite loop is created. Do not set the maximum value for the data type in *EndVal*.

Variable	Value of input parameter
InitVal	SINT#0
EndVal	SINT#127
StepVal	SINT#1
Index	---

- The following table describes operation according to the values of *StepVal*, *InitVal*, and *EndVal*.

Programming language	Value of <i>StepVal</i>	Values of <i>InitVal</i> and <i>EndVal</i>	Operation
Ladder diagram	<i>StepVal</i> > 0	<i>InitVal</i> < <i>EndVal</i>	Operation is normal.
		<i>InitVal</i> ≥ <i>EndVal</i>	The processing between the FOR and NEXT instructions is not executed even once. An error does not occur.
	<i>StepVal</i> < 0	<i>InitVal</i> < <i>EndVal</i>	The processing between the FOR and NEXT instructions is executed an indeterminate number of times. Do not use settings like these. An error does not occur.
		<i>InitVal</i> ≥ <i>EndVal</i>	The processing between the FOR and NEXT instructions is not executed even once. An error does not occur.
	<i>StepVal</i> = 0	<i>InitVal</i> < <i>EndVal</i>	An infinite loop occurs and task execution times out.
		<i>InitVal</i> ≥ <i>EndVal</i>	The processing between the FOR and NEXT instructions is not executed even once. An error does not occur.
ST	<i>StepVal</i> > 0	<i>InitVal</i> ≤ <i>EndVal</i>	Operation is normal.
		<i>InitVal</i> > <i>EndVal</i>	The processing between the FOR and END_FOR instructions is not executed even once. An error does not occur.
	<i>StepVal</i> < 0	<i>InitVal</i> < <i>EndVal</i>	The processing between the FOR and END_FOR instructions is not executed even once. An error does not occur.
		<i>InitVal</i> ≥ <i>EndVal</i>	Operation is normal.
	<i>StepVal</i> = 0	<i>InitVal</i> ≤ <i>EndVal</i>	An infinite loop occurs and task execution times out.
		<i>InitVal</i> > <i>EndVal</i>	The processing between the FOR and END_FOR instructions is not executed even once. An error does not occur.

- The FOR-NEXT loops can be nested up to 15 levels, but count all nesting levels for the following instructions: IF, CASE, FOR, WHILE, and REPEAT.
- If loops are nested, you will need one BREAK instruction (or one EXIT instruction in ST) for each nesting level to cancel all repeat processing.
- Do not use Jump Instructions (e.g., the JMP instruction) to interrupt repeat processing. Always use a BREAK instruction (or an EXIT instruction in ST) to cancel repeat processing.
- The operation to change the values of *InitVal*, *EndVal*, and *StepVal* during repeat processing is different in a ladder diagram and ST.

Variable	Operation	
	Ladder diagram	ST
<i>InitVal</i>	The new value is not applied until repeat processing is completed.	The new value is not applied until repeat processing is completed.
<i>EndVal</i>	The new value is applied even during repeat processing.	
<i>StepVal</i>	The intended operation may not occur. Do not change the value of this variable during repeat processing.	

- In a ladder diagram, use the same data type for *InitVal*, *EndVal*, *StepVal*, and *Index*. Otherwise, a building error will occur.
- Set the data type of *Index* to include the valid ranges of *InitVal*, *EndVal*, and *StepVal*. Otherwise, a building error will occur.

- The value of *Index* after repeat processing is different in a ladder diagram and ST. In a ladder diagram, the value of *StepVal* is not added to *Index* at the end of repeat processing. In ST, the value of *StepVal* is added to *Index* at the end of repeat processing. Processing is repeated the same number of times.

The following example is for when *InitVal* is 1, *EndVal* is 100 and *StepVal* is 1.

Ladder diagram: The value of *Index* will be 100 after 100 repetitions.

ST: The value of *Index* will be 101 after 100 repetitions.

- Caution is required when you specify upward or downward differentiation for a LD, AND, or OR instruction in a FOR loop in a ladder diagram and an array is used for the LD, AND, or OR instruction.

For upward or downward differentiation, the value of the specified variable at the previous execution is compared with the value of the specified variable at the current execution to determine upward or downward differentiation. Normally, the value of the specified variable does not change every time the instruction is executed. However, if an array is specified in a FOR loop, the array element changes each time the instruction is executed. Therefore, upward or downward differentiation is determined by comparing different array elements.

The following table shows the relationship between the values of $x[i-1]$ and $x[i]$, and the increment processing for $Count1[i]$.

Value of $x[i-1]$	Value of $x[i]$	Increment processing for $Count1[i]$
TRUE	TRUE	Not executed.
TRUE	FALSE	Not executed.
FALSE	TRUE	Executed.
FALSE	FALSE	Not executed.

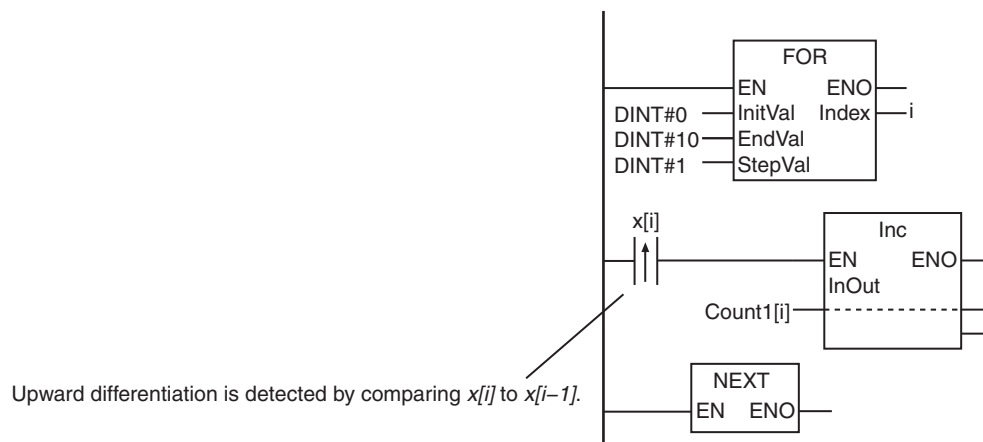

- In the following programming, upward differentiation of $x[i]$ is detected by the R_TRIG instruction. An instance of the R_TRIG instruction is provided for each element of $x[i]$, so it is possible to detect the elements of $x[i]$ for which there was upward differentiation. The following table shows the relationship between the value of $x[i]$ for the previous execution of R_TRIG_instance[i], the value of $x[i]$ for the current execution of R_TRIG_instance[i], and the increment processing of $Count2[i]$.

Value of $x[i]$ for previous execution of R_TRIG_instance[i]	Value of $x[i]$ for current execution of R_TRIG_instance[i]	Increment processing for $Count2[i]$
TRUE	TRUE	Not executed.
TRUE	FALSE	Not executed.
FALSE	TRUE	Executed.
FALSE	FALSE	Not executed.

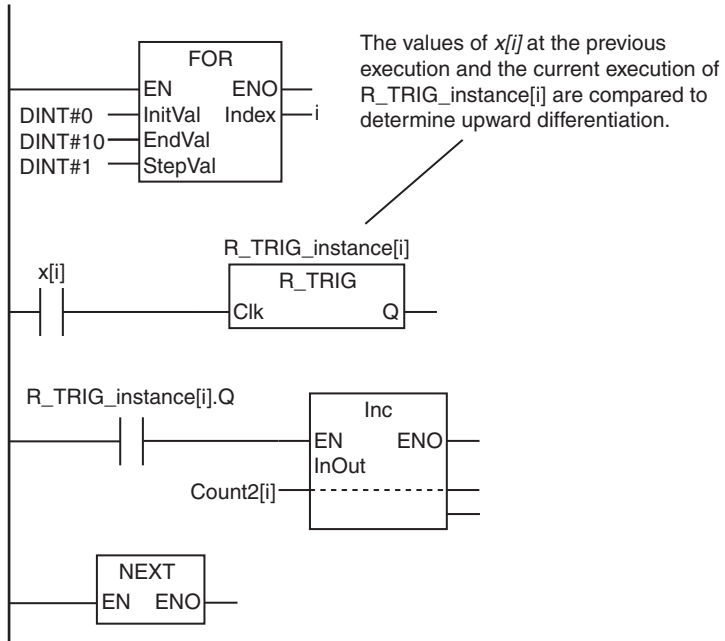

BREAK

The BREAK instruction is used to cancel repeat processing from the lowest level FOR instruction to the NEXT instruction.

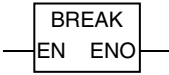
Instruction	Name	FB/FUN	Graphic expression	ST expression
BREAK	Break Loop	FUN		None

Variables

None

Function

The BREAK instruction cancels the repeat processing from the lowest level FOR instruction to the NEXT instruction. It moves processing to the next instruction after the NEXT instruction. The processing between the BREAK instruction and the NEXT instruction is not executed.

The following figure shows a programming example. When the FOR loop is executed, the value of variable *A* is checked each time. If the value of variable *A* is TRUE, the repeat processing is ended immediately. In this example, the Out instruction after the BREAK instruction is not executed, and the value of variable *C* is retained.

LD

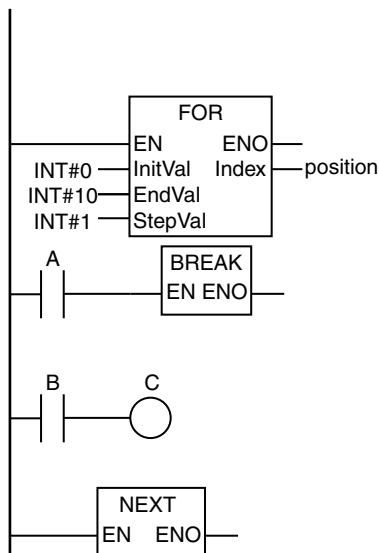

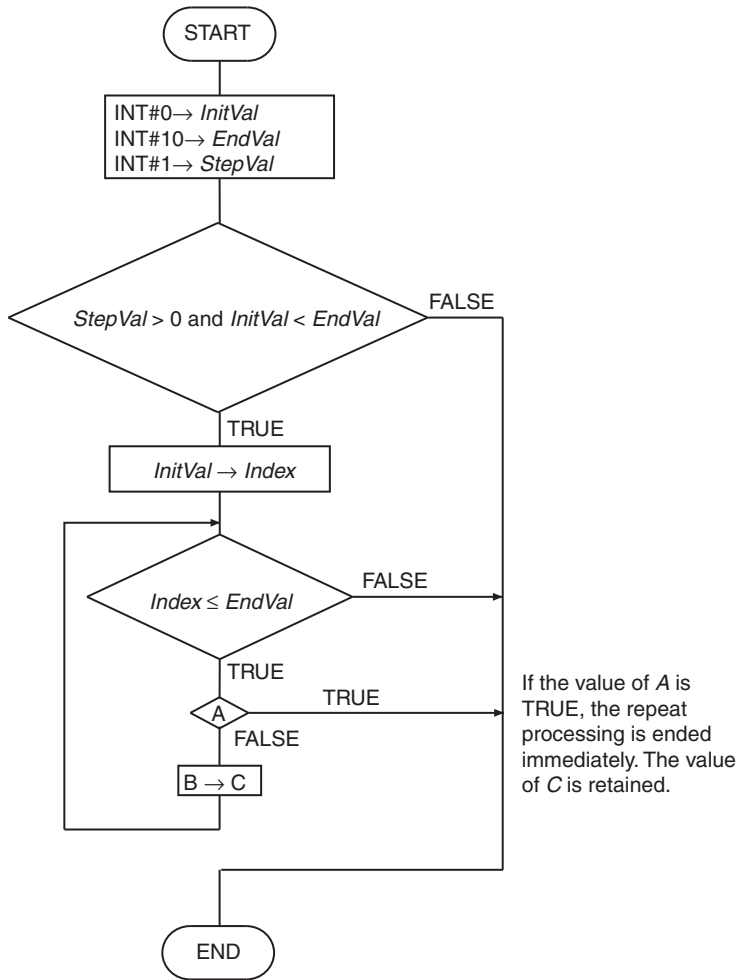

Precautions for Correct Use

- Always place this instruction between the FOR and NEXT instructions.
- If you nest FOR and NEXT instructions, one BREAK instruction is required for each nesting level to end all of the repeat processing.
- Do not use Jump Instructions (e.g., the JMP instruction) to interrupt repeat processing. Always use a BREAK instruction to cancel repeat processing.

Comparison Instructions

Instruction	Name	Page
EQ (=)	Equal	2-92
NE (<>)	Not Equal	2-94
LT (<), LE (<=), GT (>), and GE (>=)	Less Than/Less Than Or Equal/ Greater Than/Greater Than Or Equal	2-97
EQascii	Text String Comparison Equal	2-100
NEascii	Text String Comparison Not Equal	2-102
LTascii, LEascii, GTascii, and GEascii	Text String Comparison Less Than/Text String Comparison Less Than or Equal Text String Comparison Greater Than/Text String Comparison Greater Than or Equal	2-104
Cmp	Compare	2-107
ZoneCmp	Zone Comparison	2-109
TableCmp	Table Comparison	2-111
AryCmpEQ and AryCmpNE	Array Comparison Equal/ Array Comparison Not Equal	2-114
AryCmpLT, AryCmpLE, AryCmpGT, and AryCmpGE	Array Comparison Less Than/Array Comparison Less Than Or Equal Array Comparison Greater Than/Array Compari- son Greater Than Or Equal	2-116
AryCmpEQV and AryCmpNEV	Array Value Comparison Equal/Array Value Com- parison Not Equal	2-119
AryCmpLTV, AryCmpLEV, AryCmpGTV, and AryCmpGEV	Array Value Comparison Less Than/Array Value Comparison Less Than Or Equal Array Value Comparison Greater Than/Array Value Comparison Greater Than Or Equal	2-121

EQ (=)

The EQ (=) instruction determines if the contents of two or more variables are all equivalent.

Instruction	Name	FB/FUN	Graphic expression	ST expression
EQ (=)	Equal	FUN		Out:=(In1=In2) & (In2=In3) & ... & (InN-1=InN);

Variables

Name	Meaning	I/O	Description	Valid range	Unit	Default
In1 to InN	Comparison data	Input	Values to compare, N = 2 to 5	Depends on data type.	---	0*
Out	Comparison result	Output	Comparison result	Depends on data type.	---	---

* If you omit the input parameter that connects to *InN*, the default value is not applied, and a building error will occur. For example, if N is 3 and the input parameters that connect to *In1* and *In2* are omitted, the default values are applied, but if the input parameter that connects to *In3* is omitted, a building error will occur.

	Boolean	Bit strings					Integers							Real numbers	Times, durations, dates, and text strings					
	BOOL	BYTE	WORD	DWORD	LWORD	USINT	UINT	UDINT	ULINT	SINT	INT	DINT	LINT	REAL	LREAL	TIME	DATE	TOD	DT	STRING
In1 to InN	OK	OK	OK	OK	OK	OK	OK	OK	OK	OK	OK	OK	OK	OK	OK	OK	OK	OK	OK	OK
	Enumerations can also be specified.																			
Out	OK																			

* You can specify TIME, DATE, TOD, DT and STRING data with Sysmac Studio version 1.02 or higher. If you open a project that was created with Sysmac Studio version 1.01 or lower on Sysmac Studio version 1.02 or higher and then use any of these data types, refresh the display. To refresh the display, right-click the instruction in the Edit Pane and select **Update**. If you do not refresh the display, a building error will occur.

Function

The EQ (=) instruction determines if the contents of from two to five variables *In1* to *InN* are all equivalent. The comparison result *Out* is TRUE only when all values are equivalent. Otherwise, the value of *Out* is FALSE.

When comparing STRING data, “equivalent” means that both the lengths and contents of the text strings are the same.

The following example is for when *In1* is INT#3, *In2* is INT#5 and *In3* is INT#10. The value of variable *abc* will be FALSE.

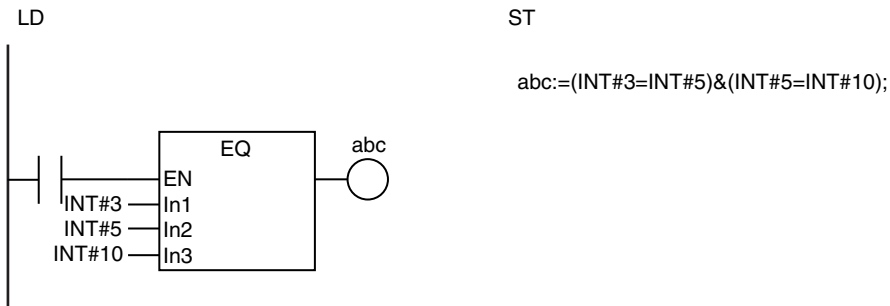

The EQ instruction determines if *In1* to *In3* are all equivalent. If they are different, the value of *abc* will be FALSE.

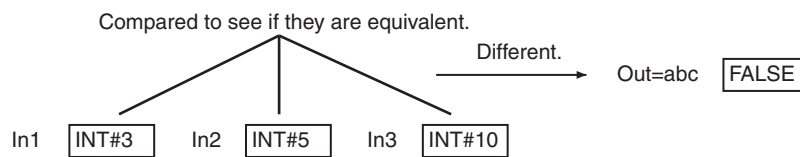

Additional Information

- The functions of the EQ instruction and the = instruction are exactly the same. Use the form that is easier to use.
- When you compare TIME, DT, or TOD data, adjust the data so that the precision of the values is the same. Use the following instructions to adjust the precision of the values: TruncTime (page 2-652), TruncDt (page 2-656), and TruncTod (page 2-660).

Precautions for Correct Use

- If the data types of *In1* to *InN* are different, they will be expanded to a data type that includes the ranges of all of the data types.
- You cannot compare bit string data (BYTE, WORD, DWORD, or LWORD) with integers. You cannot compare bit string data to real number data (SINT, INT, DINT, LINT, USINT, UDINT, ULINT, REAL, and LREAL).
- Signed integers (SINT, INT, DINT, and LINT) cannot be compared to unsigned integers (USINT, UINT, UDINT, and ULINT).
- Always compare data with the same data type for TIME, DATE, TOD, DT, and STRING data. If variables with different data types are specified, a building error will occur.
- You can compare enumerations only to other enumerations. The data types must also be the same to compare enumerations.
- Two values that are positive infinity or two values that are negative infinity are equivalent.
- If any of the values of *In1* to *InN* is nonnumeric data, the value of *Out* is FALSE.
- If this instruction is used in a ladder diagram, the value of *Out* changes to FALSE if an error occurs in the previous instruction on the rung.
- If *In1* to *InN* are real numbers, the desired results may not be achieved due to rounding error. Do not use this instruction to check if two values are equal when one or more of them is a real number. Use a value comparison instruction and check to see if the difference in the absolute values is within the allowable range. For example, the following programming can be used to check to see if the sum of REAL variables *real_a* and *real_b* is equal to 0.1. If the value of BOOL variable *boolv* is TRUE, the two values are considered to be equal.

```
boolv := (ABS((real_a + real_b) - 0.1) < threshold);
```

threshold: Value for allowable range

NE (<>)

The NE (<>) instruction determines if the contents of two variables are not equivalent.

Instruction	Name	FB/FUN	Graphic expression	ST expression
NE (<>)	Not Equal	FUN		Out:=(In1<>In2);

Variables

Name	Meaning	I/O	Description	Valid range	Unit	Default
In1 and In2	Comparison data	Input	Values to compare	Depends on data type.	---	*
Out	Comparison result	Output	Comparison result	Depends on data type.	---	---

* If you omit an input parameter, the default value is not applied. A building error will occur.

	Boolean	Bit strings					Integers							Real numbers	Times, durations, dates, and text strings						
	BOOL	BYTE	WORD	DWORD	LWORD	USINT	UINT	UDINT	ULINT	SINT	INT	DINT	LINT	REAL	LREAL	TIME	DATE	TOD	DT	STRING	
In1 and In2	OK	OK	OK	OK	OK	OK	OK	OK	OK	OK	OK	OK	OK	OK	OK	OK	OK	OK	OK	OK	*
Enumerations can also be specified.																					
Out	OK																				

* You can specify TIME, DATE, TOD, DT, and STRING data with Sysmac Studio version 1.02 or higher. If you open a project that was created with Sysmac Studio version 1.01 or lower on Sysmac Studio version 1.02 or higher and then use any of these data types, refresh the display. To refresh the display, right-click the instruction in the Edit Pane and select **Update**. If you do not refresh the display, a building error will occur.

Function

The NE (<>) instruction determines if the contents of two variables *In1* and *In2* are not equivalent. If they are not equivalent, the comparison result *Out* is TRUE. If they are equivalent, *Out* is FALSE. When comparing STRING data, “equivalent” means that both the lengths and contents of the text strings are the same.

The following example is for when *In1* equals *In2* (both have a value of INT#5). The value of variable *abc* will be FALSE.

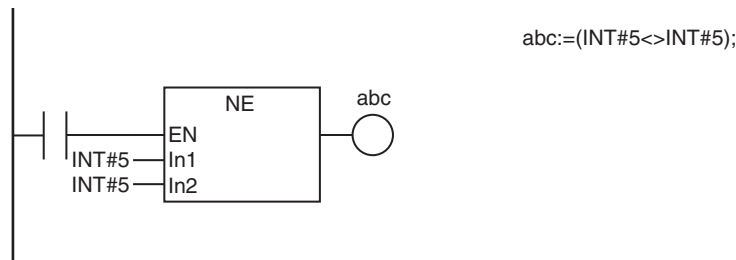

The NE instruction determines if *In1* and *In2* are different. If they are the same, the value of *abc* will be FALSE.

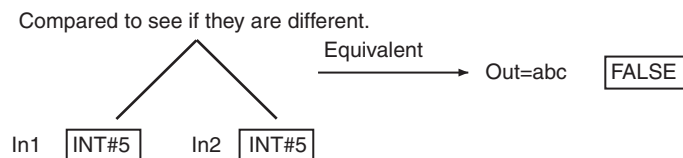

Additional Information

- The functions of the NE instruction and the <> instruction are exactly the same. Use the form that is easier to use.
- When you compare TIME, DT, or TOD data, adjust the data so that the precision of the values is the same. Use the following instructions to adjust the precision of the values: TruncTime (page 2-652), TruncDt (page 2-656), and TruncTod (page 2-660).

Precautions for Correct Use

- If the data types of *In1* and *In2* are different, the smaller one is expanded to a data type that includes the ranges of both of the data types.
- You cannot compare bit string data (BYTE, WORD, DWORD, or LWORD) with integers (SINT, INT, DINT, LINT, USINT, UDINT, ULINT). You cannot compare bit string data with real number data (REAL and LREAL).
- Signed integers (SINT, INT, DINT, and LINT) cannot be compared to unsigned integers (USINT, UINT, UDINT, and ULINT).
- Always compare data with the same data type for TIME, DATE, TOD, DT, and STRING data. If variables with different data types are specified, a building error will occur.
- You can compare enumerations only to other enumerations. The data types must also be the same to compare enumerations.
- Two values that are positive infinity or two values that are negative infinity are equivalent.
- If the value of either *In1* or *In2* is nonnumeric data, the value of *Out* is TRUE.
- If this instruction is used in a ladder diagram, the value of *Out* changes to FALSE if an error occurs in the previous instruction on the rung.

- If *In1* and *In2* are real numbers, the desired results may not be achieved due to rounding error. Do not use this instruction to check if two values are different when one or both of them is a real number. Use a value comparison instruction and check to see if the difference in the absolute values is greater than the allowable range. For example, the following programming can be used to check to see if the sum of REAL variables *real_a* and *real_b* is not equal to 0.1. If the value of BOOL variable *boolv* is TRUE, the two values are considered to be not equal.

```
boolv := (ABS((real_a + real_b) - 0.1) > threshold);
```

threshold: Value for allowable range

LT (<), LE (<=), GT (>), and GE (>=)

These instructions compare the sizes of two or more values.

- LT (<): Performs a less than comparison.
- LE (<=): Performs a less than or equal comparison.
- GT (>): Performs a greater than comparison.
- GE (>=): Performs a greater than or equal comparison.

Instruction	Name	FB/FUN	Graphic expression	ST expression
LT (<)	Less Than	FUN		Out:=(In1<In2) & (In2<In3) & ... & (InN-1<InN);
LE (<=)	Less Than Or Equal	FUN		Out:=(In1<=In2) & (In2<=In3) & ... & (InN-1<=InN);
GT (>)	Greater Than	FUN		Out:=(In1>In2) & (In2>In3) & ... & (InN-1>InN);
GE (>=)	Greater Than Or Equal	FUN		Out:=(In1>=In2) & (In2>=In3) & ... & (InN-1>=InN);

Variables

Name	Meaning	I/O	Description	Valid range	Unit	Default
In1 to InN	Comparison data	Input	Values to compare, N = 2 to 5	Depends on data type.	---	0*
Out	Comparison result	Output	Comparison result	Depends on data type.	---	---

* If you omit the input parameter that connects to *InN*, the default value is not applied, and a building error will occur. For example, if N is 3 and the input parameters that connect to *In1* and *In2* are omitted, the default values are applied, but if the input parameter that connects to *In3* is omitted, a building error will occur.

	Boolean	Bit strings					Integers							Real numbers		Times, durations, dates, and text strings				
	BOOL	BYTE	WORD	DWORD	LWORD	USINT	UINT	UDINT	ULINT	SINT	INT	DINT	LINT	REAL	LREAL	TIME	DATE	TOD	DT	STRING
In1 to InN		OK	OK	OK	OK	OK	OK	OK	OK	OK	OK	OK	OK	OK	OK	OK	OK	OK	OK	OK
Out	OK																			

* You can specify BYTE, WORD, DWORD, LWORD, TIME, DATE, TOD, DT, and STRING data with Sysmac Studio version 1.02 or higher. If you open a project that was created with Sysmac Studio version 1.01 or lower on Sysmac Studio version 1.02 or higher and then use any of these data types, refresh the display. To refresh the display, right-click the instruction in the Edit Pane and select **Update**. If you do not refresh the display, a building error will occur.

Function

These instructions compare the data in *In1* to *InN* (N = 2 to 5).

The output value *Out* is shown below for each instruction.

Instruction	Value of <i>Out</i>
LT (<)	If $In1 < In2 < \dots < InN$, <i>Out</i> is TRUE. Otherwise, it is FALSE.
LE (<=)	If $In1 \leq In2 \leq \dots \leq InN$, <i>Out</i> is TRUE. Otherwise, it is FALSE.
GT (>)	If $In1 > In2 > \dots > InN$, <i>Out</i> is TRUE. Otherwise, it is FALSE.
GE (>=)	If $In1 \geq In2 \geq \dots \geq InN$, <i>Out</i> is TRUE. Otherwise, it is FALSE.

The relationship between values with data types that are not integers or real numbers are determined as given in the following table.

Data type	Relationship
BYTE, WORD, DWORD, or LWORD	The data is compared as unsigned integers.
TIME	The numerically larger value is considered to be larger.
DATE, TOD, or DT	Later dates or times of day are considered to be larger.
STRING	The specifications are the same as for the LTascii, LEascii, GTascii, and GEascii instructions (page 2-104). Refer to the specified page for details.

The following example shows the LE instruction when *In1* is INT#3, *In2* is INT#5 and *In3* is INT#10. The value of variable *abc* will be TRUE.

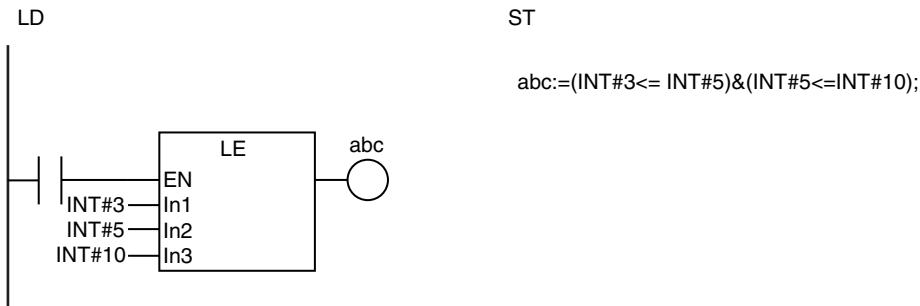

The LE instruction determines if $In1 \leq In2 \leq In3$. If the comparison conditions are met, the value of *abc* will be TRUE.

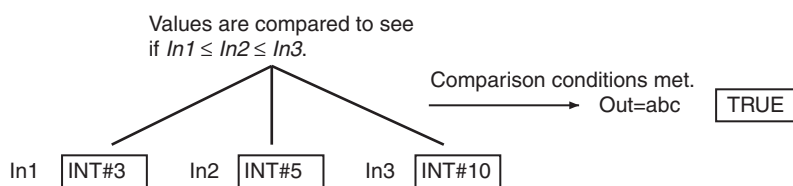

Additional Information

- The functions of the LT and < instructions, the LE and <= instructions, the GT and > instructions, and the GE and >= instructions are exactly the same. Use the form that is easier to use.
- When you compare TIME, DT, or TOD data, adjust the data so that the precision of the values is the same. Use the following instructions to adjust the precision of the values: TruncTime (page 2-652), TruncDt (page 2-656), and TruncTod (page 2-660).

Precautions for Correct Use

- If the data types of *In1* to *InN* are different, they will be expanded to a data type that includes the ranges of all of the data types.
- Signed integers (SINT, INT, DINT, and LINT) cannot be compared to unsigned integers (USINT, UINT, UDINT, and ULINT).
- You cannot compare bit string data (BYTE, WORD, DWORD, or LWORD) with integers (SINT, INT, DINT, LINT, USINT, UINT, UDINT, or ULINT). You cannot compare bit string data with real number data (REAL or LREAL).
- Always compare data with the same data type for TIME, DATE, TOD, DT, and STRING data. If variables with different data types are specified, a building error will occur.
- If *In1* to *InN2* are real numbers, error may cause unexpected processing results. This can occur, for example, when they contain non-terminating decimal numbers.
- Two values that are positive infinity or two values that are negative infinity are equivalent.
- If any of the values of *In1* to *InN* is nonnumeric data, the value of *Out* is FALSE.
- If this instruction is used in a ladder diagram, the value of *Out* changes to FALSE if an error occurs in the previous instruction on the rung.

EQascii

The EQascii instruction determines if two or more text strings are all equivalent.

Instruction	Name	FB/FUN	Graphic expression	ST expression
EQascii	Text String Comparison Equal	FUN		Out:=EQascii(In1, ..., InN);

Variables

Name	Meaning	I/O	Description	Valid range	Unit	Default
In1 to InN	Comparison text strings	Input	Text strings to compare, N = 2 to 5	Depends on data type.	---	" "
Out	Comparison result	Output	Comparison result	Depends on data type.	---	---

* If you omit the input parameter that connects to *InN*, the default value is not applied, and a building error will occur. For example, if N is 3 and the input parameters that connect to *In1* and *In2* are omitted, the default values are applied, but if the input parameter that connects to *In3* is omitted, a building error will occur.

	Boolean	Bit strings					Integers							Real numbers		Times, durations, dates, and text strings					
		BOOL	BYTE	WORD	DWORD	LWORD	USINT	UINT	UDINT	ULINT	SINT	INT	DINT	LINT	REAL	LREAL	TIME	DATE	TOD	DT	STRING
In1 to InN																					OK
Out	OK																				

Function

The EQascii instruction determines if from two to five text strings *In1* to *InN* are all equivalent. If they are all equivalent, comparison result *Out* changes to TRUE. Otherwise, the value of *Out* is FALSE. “Equivalent” means that both the lengths and contents of the text strings are the same.

The following example is for when *In1* is “A”, *In2* is “AB”, and *In3* is “ABC”. The value of variable *abc* will be FALSE.

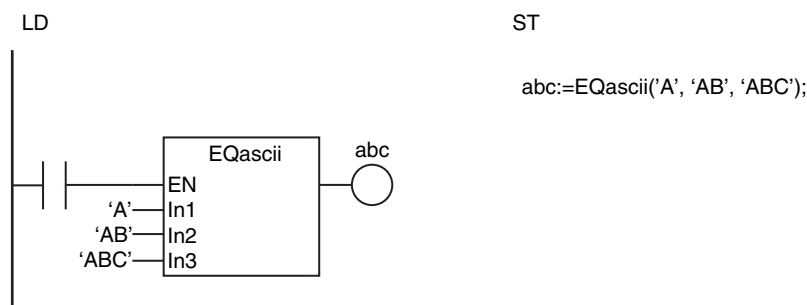

The EQascii instruction determines if *In1* to *In3* are all equivalent.
If they are different, the value of *abc* will be FALSE.

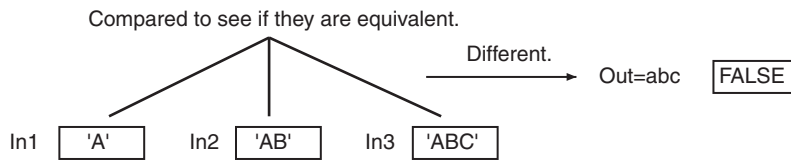

Additional Information

The text string comparison instructions are convenient when you want to reorder text strings according to the character codes. For example, the character codes for alphabet characters are in the same order as the alphabet characters. This allows you to alphabetize.



Version Information

With Sysmac Studio version 1.02 or higher, the EQ (=) instruction (page 2-92) can also be used to compare text strings. The specifications of the EQ (=) instruction for comparing text strings are the same as for the EQascii instruction.

Precautions for Correct Use

- Do not use this instruction as the rightmost instruction on a rung. If you do, an error occurs on the Sysmac Studio and you cannot transfer the user program to the Controller.
- If this instruction is used in a ladder diagram, the value of *Out* changes to FALSE if an error occurs in the previous instruction on the rung.
- Specify text strings that contain only ASCII characters for *In1* to *InN*.

NEascii

The NEascii instruction determines if two text strings are not equivalent.

Instruction	Name	FB/FUN	Graphic expression	ST expression
NEascii	Text String Comparison Not Equal	FUN		Out:=NEascii(In1, In2);

Variables

Name	Meaning	I/O	Description	Valid range	Unit	Default
In1 and In2	Comparison text strings	Input	Text strings to compare	Depends on data type.	---	*
Out	Comparison result	Output	Comparison result	Depends on data type.	---	---

* If you omit an input parameter, the default value is not applied. A building error will occur.

	Boolean	Bit strings					Integers							Real numbers		Times, durations, dates, and text strings				
	BOOL	BYTE	WORD	DWORD	LWORD	USINT	UINT	UDINT	ULINT	SINT	INT	DINT	LINT	REAL	LREAL	TIME	DATE	TOD	DT	STRING
In1 and In2																				OK
Out	OK																			

Function

The NEascii instruction determines if two text strings *In1* and *In2* are not equivalent. If they are different, comparison result *Out* will be TRUE. If they are the same, comparison result *Out* will be FALSE. “Equivalent” means that both the lengths and contents of the text strings are the same.

The following example is for when *In1* is “A” and *In2* is “AB”. The value of variable *abc* will be TRUE.

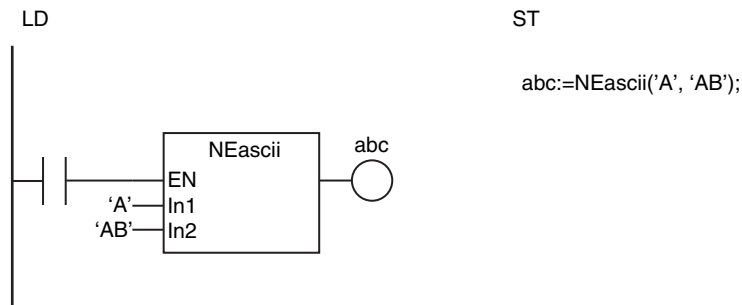

The NEascii instruction determines if *In1* and *In2* are different. If they are different, the value of *abc* will be TRUE.

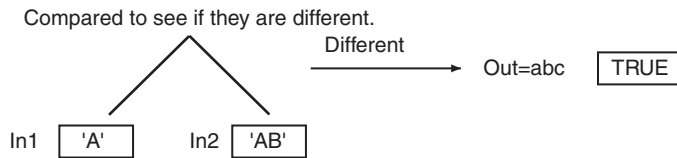

Additional Information

The text string comparison instructions are convenient when you want to reorder text strings according to the character codes. For example, the character codes for alphabet characters are in the same order as the alphabet characters. This allows you to alphabetize.



Version Information

With Sysmac Studio version 1.02 or higher, the NE (<>) instruction (page 2-94) can also be used to compare text strings. The specifications of the NE (<>) instruction for comparing text strings are the same as for the NEascii instruction.

Precautions for Correct Use

- Do not use this instruction as the rightmost instruction on a rung. If you do, an error occurs on the Sysmac Studio and you cannot transfer the user program to the Controller.
- If this instruction is used in a ladder diagram, the value of *Out* changes to FALSE if an error occurs in the previous instruction on the rung.
- Specify text strings that contain only ASCII characters for *In1* and *In2*.

LTascii, LEascii, GTascii, and GEascii

These instructions compare the sizes of two or more text strings.

LTascii: Performs a less than comparison.

LEascii: Performs a less than or equal comparison.

GTascii: Performs a greater than comparison.

GEascii: Performs a greater than or equal comparison.

Instruction	Name	FB/FUN	Graphic expression	ST expression
LTascii	Text String Comparison Less Than	FUN		Out:=LTascii(In1, ..., InN);
LEascii	Text String Comparison Less Than or Equal	FUN		Out:=LEascii(In1, ..., InN);
GTascii	Text String Comparison Greater Than	FUN		Out:=GTascii(In1, ..., InN);
GEascii	Text String Comparison Greater Than or Equal	FUN		Out:=GEascii(In1, ..., InN);

Variables

Name	Meaning	I/O	Description	Valid range	Unit	Default
In1 to InN	Comparison text strings	Input	Text strings to compare, N = 2 to 5	Depends on data type.	---	**
Out	Comparison result	Output	Comparison result	Depends on data type.	---	---

* If you omit the input parameter that connects to *InN*, the default value is not applied, and a building error will occur. For example, if N is 3 and the input parameters that connect to *In1* and *In2* are omitted, the default values are applied, but if the input parameter that connects to *In3* is omitted, a building error will occur.

	Boolean	Bit strings					Integers							Real numbers		Times, durations, dates, and text strings				
	BOOL	BYTE	WORD	DWORD	LWORD	USINT	UINT	UDINT	ULINT	SINT	INT	DINT	LINT	REAL	LREAL	TIME	DATE	TOD	DT	STRING
In1 to InN																				OK
Out	OK																			

Function

These instructions compare the sizes of from two to five text strings in *In1* to *InN* ($N = 2$ to 5). The output value *Out* is shown below for each instruction.

Instruction	Value of <i>Out</i>
LTascii	If $In1 < In2 < \dots < InN$, <i>Out</i> is TRUE. Otherwise, it is FALSE.
LEascii	If $In1 \leq In2 \leq \dots \leq InN$, <i>Out</i> is TRUE. Otherwise, it is FALSE.
GTascii	If $In1 > In2 > \dots > InN$, <i>Out</i> is TRUE. Otherwise, it is FALSE.
GEascii	If $In1 \geq In2 \geq \dots \geq InN$, <i>Out</i> is TRUE. Otherwise, it is FALSE.

The sizes of the character codes are compared. The comparison procedure is as follows:

First, the first character codes in all of the text strings are compared. If the character codes are different, the result of the size comparison for the text strings is determined by the size relationship between those character codes. If the character codes are the same, comparison continues in order to the other characters until a different character code is found. If the lengths of the text strings are different, NULL characters (16#00) are added to the shorter text string to complete the comparison.

The relationships between various text strings are as follows:

```
'AD'(16#414400) < 'BC'(16#424400)
'ADC' (16#41444300) < 'B'(16#42000000)
'ABC' (16#41424300) < 'ABD'(16#41424400)
'ABC' (16#41424300) > 'AB'(16#41420000)
'AB' (16#414200) = 'AB'(16#414200)
```

If the text string contains multi-byte characters, the characters are separated into individual bytes before comparison. For example, the two-byte character 16#C281 is handled as 16#C2 and 16#81.

The following example for the LEascii instruction is for when *In1* is "AB", *In2* is "AC", and *In3* is "AC". The value of variable *abc* will be TRUE.

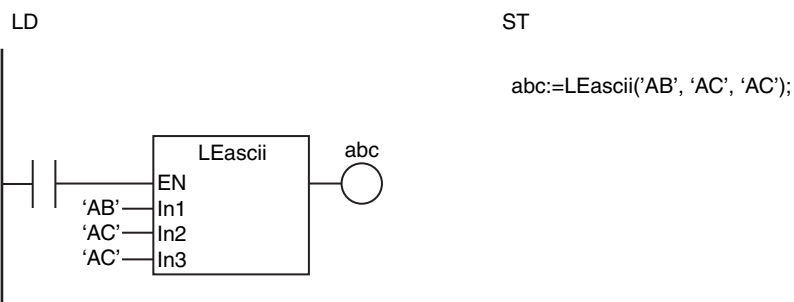

The LEascii instruction determines if $In1 \leq In2 \leq In3$.
If the comparison conditions are met, the value of *abc* will be TRUE.

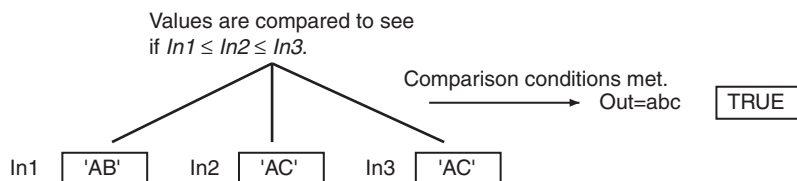

Additional Information

The text string comparison instructions are convenient when you want to reorder text strings according to the character codes. For example, the character codes for alphabet characters are in the same order as the alphabet characters. This allows you to alphabetize.



Version Information

With Sysmac Studio version 1.02 or higher, the LT (<), LE (<=), GT (>), and GE (>=) instructions (page 2-97) can also be used to compare text strings. The specifications of the LT (<), LE (<=), GT (>), and GE (>=) instructions for comparing text strings are the same as for the LTascii, LEascii, GTascii, and GEascii instructions.

Precautions for Correct Use

- Do not use this instruction as the rightmost instruction on a rung. If you do, an error occurs on the Sysmac Studio and you cannot transfer the user program to the Controller.
- If this instruction is used in a ladder diagram, the value of *Out* changes to FALSE if an error occurs in the previous instruction on the rung.
- Specify text strings that contain only ASCII characters for *In1* to *InN*.

Cmp

The Cmp instruction compares two values.

Instruction	Name	FB/FUN	Graphic expression	ST expression
Cmp	Compare	FUN		Out:=Cmp(In1, In2, OutEQ, OutGT, OutGE, OutNE, OutLT, OutLE); You can omit <i>Out</i> .

Variables

Name	Meaning	I/O	Description	Valid range	Unit	Default
In1 and In2	Comparison data	Input	Values to compare	Depends on data type.	---	*
Out	Return value	Output	Always TRUE	TRUE only	---	---
OutEQ	Equal flag		Equal flag	Depends on data type.		
OutGT	Greater than flag		Greater than flag			
OutGE	Greater than or equal flag		Greater than or equal flag			
OutNE	Not equal flag		Not equal flag			
OutLT	Less than flag		Less than flag			
OutLE	Less than or equal flag		Less than or equal flag			

* If you omit the input parameter, the default value is not applied. A building error will occur.

	Boolean	Bit strings				Integers							Real numbers	Times, durations, dates, and text strings						
	BOOL	BYTE	WORD	DWORD	LWORD	USINT	UINT	UDINT	ULINT	SINT	INT	DINT	LINT	REAL	LREAL	TIME	DATE	TOD	DT	STRING
In1 and In2						OK	OK	OK	OK	OK	OK	OK	OK	OK						
Out	OK																			
OutEQ	OK																			
OutGT	OK																			
OutGE	OK																			
OutNE	OK																			
OutLT	OK																			
OutLE	OK																			

Function

The Cmp instruction compares two values (*In1* and *In2*) and outputs flag values.

The values of the flags are as follows:

Flag	Value
OutEQ	If <i>In1</i> equals <i>In2</i> , the flag shows TRUE. Otherwise the flag shows FALSE.
OutGT	If <i>In1</i> is greater than <i>In2</i> , the flag shows TRUE. Otherwise the flag shows FALSE.
OutGE	If <i>In1</i> is greater than or equal to <i>In2</i> , the flag shows TRUE. Otherwise the flag shows FALSE.
OutNE	If <i>In1</i> is not equal to <i>In2</i> , the flag shows TRUE. Otherwise the flag shows FALSE.
OutLT	If <i>In1</i> is less than <i>In2</i> , the flag shows TRUE. Otherwise the flag shows FALSE.
OutLE	If <i>In1</i> is less than or equal to <i>In2</i> , the flag shows TRUE. Otherwise the flag shows FALSE.

The following example is for when *In1* is INT#10 and *In2* is INT#20. The values of variables *def*, *ghi*, and *jkl* will be FALSE, and the values of *abc*, *mno*, *pqr*, and *stu* will be TRUE.

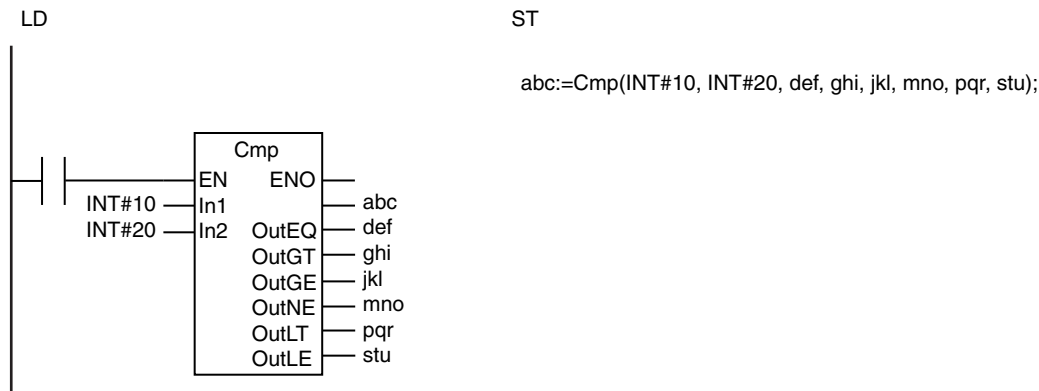

The Cmp instruction compares *In1* and *In2*.
The results are given below for the various criteria.

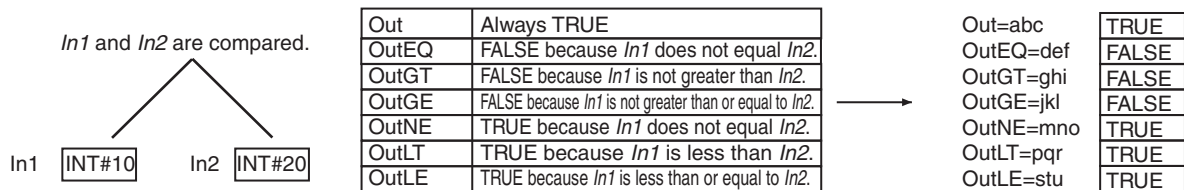

Precautions for Correct Use

- If the data types of *In1* and *In2* are different, the smaller one is expanded to a data type that includes the ranges of both of the data types.
- If *In1* and *In2* are real numbers, error may cause unexpected processing results. This can occur, for example, when they contain non-terminating decimal numbers.
- Signed integers (SINT, INT, DINT, and LINT) cannot be compared to unsigned integers (USINT, UINT, UDINT, and ULINT).
- Two values that are positive infinity or two values that are negative infinity are equivalent.
- If the value of either *In1* or *In2* is nonnumeric data, the values of *OutEQ*, *OutGT*, *OutGE*, *OutNE*, *OutLT*, and *OutLE* are FALSE.

ZoneCmp

The ZoneCmp instruction determines if the comparison data is within the specified maximum and minimum values.

Instruction	Name	FB/FUN	Graphic expression	ST expression
ZoneCmp	Zone Comparison	FUN		Out:=ZoneCmp(MN, In, MX);

Variables

Name	Meaning	I/O	Description	Valid range	Unit	Default
MN	Minimum value	Input	Minimum value	Depends on data type.	---	0
In	Comparison data		Value to compare			*
MX	Maximum value		Maximum value			0
Out	Comparison result	Output	Comparison result	Depends on data type.	---	---

* If you omit an input parameter, the default value is not applied. A building error will occur.

	Boolean	Bit strings				Integers								Real numbers	Times, durations, dates, and text strings						
	BOOL	BYTE	WORD	DWORD	LWORD	USINT	UINT	UDINT	ULINT	SINT	INT	DINT	LINT	REAL	LREAL	TIME	DATE	TOD	DT	STRING	
MN						OK	OK	OK	OK	OK	OK	OK	OK	OK	OK	OK	OK	OK	OK	OK	*
In						OK	OK	OK	OK	OK	OK	OK	OK	OK	OK	OK	OK	OK	OK	OK	*
MX						OK	OK	OK	OK	OK	OK	OK	OK	OK	OK	OK	OK	OK	OK	OK	*
Out	OK																				

* You can specify TIME, DATE, TOD, and DT data with CPU Units with unit version 1.01 or later and Sysmac Studio version 1.02 or higher.

TableCmp

The TableCmp instruction compares the comparison data with multiple defined ranges in a comparison table.

Instruction	Name	FB/FUN	Graphic expression	ST expression
TableCmp	Table Comparison	FUN		Out:=TableCmp(In, Table, Size, AryOut);

Variables

Name	Meaning	I/O	Description	Valid range	Unit	Default
In	Comparison data	Input	Value to compare	Depends on data type.	---	*
Table[] (two-dimensional array)	Comparison table		Two-dimensional array that contains the elements for the defined ranges			
Size	Comparison size		Number of elements in <i>Table[]</i> to which to compare <i>In</i>			
AryOut[] (array)	Individual comparison results array	In-out	Comparison results for <i>Table[]</i> elements TRUE: Condition met. FALSE: Condition not met.	Depends on data type.	---	---
Out	Comparison result	Output	TRUE: <i>In</i> meets all comparison conditions for elements of <i>Table[]</i> . FALSE: The comparison condition is not met for one or more sets of elements.	Depends on data type.	---	---

* If you omit an input parameter, the default value is not applied. A building error will occur.

	Boolean	Bit strings					Integers							Real numbers		Times, durations, dates, and text strings				
	BOOL	BYTE	WORD	DWORD	LWORD	USINT	UINT	UDINT	ULINT	SINT	INT	DINT	LINT	REAL	LREAL	TIME	DATE	TOD	DT	STRING
In						OK	OK	OK	OK	OK	OK	OK	OK	OK	OK					
Table[] (two-dimensional array)	Must be a two-dimensional array with elements that have the same data type as <i>In</i> .																			
Size							OK													
AryOut[] (array)	OK																			
Out	OK																			

Function

The TableCmp instruction compares comparison data *In* with the number of defined ranges specified by the value of *Size* in comparison table *Table[]*.

Table[] is a two-dimensional array. The first dimension contains the numbers of the defined ranges. In the second dimension, element 0 is set value A of the defined range and element 1 is set value B of the defined range.

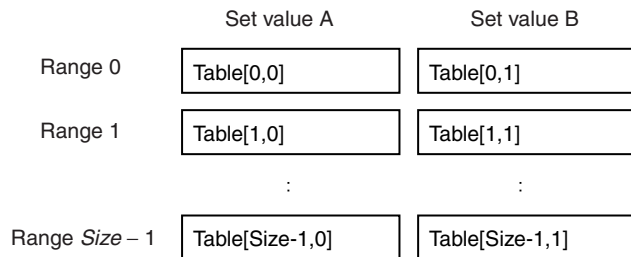

Set value A and set value B define range as shown below. Set value A and set value B are always included in the range.

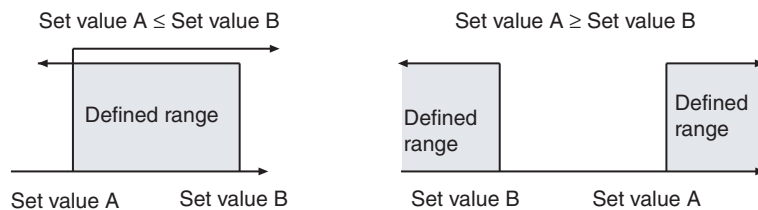

The results of comparing *In* and *Table[]* are stored in individual comparison results array *AryOut[]*. If *In* is within the defined range for element *i*, *AryOut[i]* will be TRUE. If it is not within the range, *AryOut[i]* will be FALSE. If all *Size* elements of *AryOut[]* are TRUE, comparison result *Out* will be TRUE. Otherwise, it will be FALSE.

The following example is for when *In* is INT#120 and *Size* is UINT#3.

LD

ST

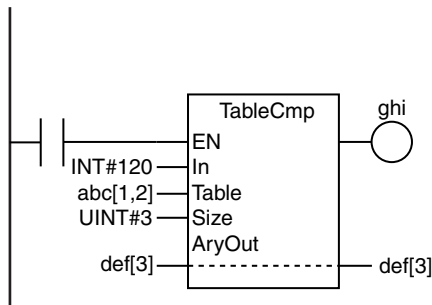

```
ghi:=TableCmp(INT#120, abc[1,2], UINT#3, def[3]);
```

In=INT#120

Size=UINT#3	$\left\{ \begin{array}{l} \text{Table}[0,0]=\text{abc}[1,2] \\ \text{Table}[1,0]=\text{abc}[2,2] \\ \text{Table}[2,0]=\text{abc}[3,2] \end{array} \right.$	0	Table[0,1]=abc[1,3]	99	→	AryOut[0]=def[3]	FALSE
		100	Table[1,1]=abc[2,3]	199	→	AryOut[1]=def[4]	TRUE
		200	Table[2,1]=abc[3,3]	299	→	AryOut[2]=def[5]	FALSE
						Out=ghi	FALSE

Precautions for Correct Use

- Use the same data type for *In* and *Table[]*. Otherwise, a building error will occur.
- Use a two-dimensional array for *Table[]*.
- If an array with more than two dimensions is used for *Table[]*, the elements in the third and higher dimensions are ignored.
- If the *AryOut[]* array is larger than the value of *Size*, the comparison results will be stored in *AryOut[0]* to *AryOut[Size-1]*. Other elements of the array will not change.
- Signed integers (SINT, INT, DINT, and LINT) cannot be compared to unsigned integers (USINT, UINT, UDINT, and ULINT).
- If real numbers are compared, error may cause unexpected processing results. This can occur, for example, when they contain non-terminating decimal numbers.
- If the value of *Size* is 0, the value of *Out* will be FALSE and *AryOut[]* will not change.
- If this instruction is used in a ladder diagram, the value of *Out* changes to FALSE if an error occurs in the previous instruction on the rung.
- An error occurs in the following cases. *Out* will be FALSE.
 - If the value of *Size* exceeds the size of the *AryOut[]* array.
 - If the value of *Size* exceeds the size of the first dimension of the *Table[]* array.
 - The size of the second dimension of *Table []* is 1.

AryCmpEQ and AryCmpNE

These instructions compare the values of the elements of two arrays.

AryCmpEQ: Determines if the elements are equal.

AryCmpNE: Determines if the elements are not equal.

Instruction	Name	FB/FUN	Graphic expression	ST expression
AryCmpEQ	Array Comparison Equal	FUN		AryCmpEQ(In1, In2, Size, AryOut);
AryCmpNE	Array Comparison Not Equal	FUN		AryCmpNE(In1, In2, Size, AryOut);

Variables

Name	Meaning	I/O	Description	Valid range	Unit	Default
In1[] and In2[] (arrays)	Comparison arrays	Input	Arrays containing the elements to compare	Depends on data type.		*
Size	Number of comparison elements		Number of elements to compare	Depends on data type.	---	1
AryOut[] (array)	Comparison results array	In-out	Comparison results array	Depends on data type.	---	---
Out	Return value	Output	Always TRUE	TRUE only	---	---

* If you omit an input parameter, the default value is not applied. A building error will occur.

	Boolean	Bit strings					Integers							Real numbers		Times, durations, dates, and text strings				
	BOOL	BYTE	WORD	DWORD	LWORD	USINT	UINT	UDINT	ULINT	SINT	INT	DINT	LINT	REAL	LREAL	TIME	DATE	TOD	DT	STRING
In1[] (array)	OK	OK	OK	OK	OK	OK	OK	OK	OK	OK	OK	OK	OK	OK						
In2[] (array)	Must be an array with the same data type as In1[].																			
Size							OK													
AryOut[] (array)	OK																			
Out	OK																			

Function

These instructions compare the values of the elements with the same element numbers in two arrays ($In1[0]$ to $In1[Size-1]$ and $In2[0]$ and $In2[Size-1]$). The comparison results are stored in comparison results array $AryOut[i]$ in the elements with the corresponding element numbers ($AryOut[0]$ to $AryOut[Size-1]$).

The value of $AryOut[i]$ is as follows for each instruction:

Instruction	Value of $AryOut[i]$
AryCmpEQ	If $In1[i] = In2[i]$, the result is TRUE. Otherwise, it is FALSE.
AryCmpNE	If $In1[i] \neq In2[i]$, the result is TRUE. Otherwise, it is FALSE.

The following example shows the AryCmpEQ instruction when $Size$ is $UINT\#3$.

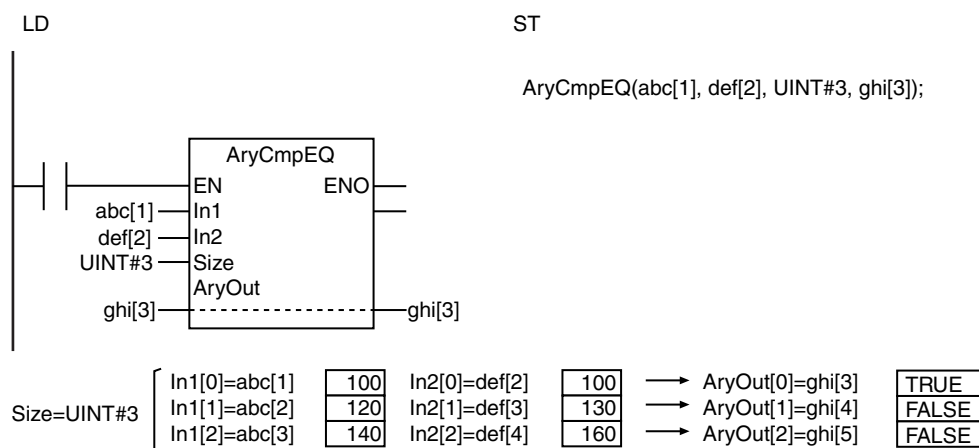

Precautions for Correct Use

- Use the same data type for $In1[i]$ and $In2[i]$. If they are different, a building error will occur.
- Use an $AryOut[i]$ array that is at least as large as the value of $Size$.
- If $In1[i]$ and $In2[i]$ contain real numbers, error may cause unexpected processing results. This can occur, for example, when they contain non-terminating decimal numbers.
- If the value of $Size$ is 0, the value of Out will be TRUE and $AryOut[i]$ will not change.
- Return value Out is not used when the instruction is used in ST.
- An error occurs in the following cases. ENO will be FALSE, and $AryOut[i]$ will not change.
 - If the $In1[i]$, $In2[i]$, or $AryOut[i]$ array is smaller than the value of $Size$.

AryCmpLT, AryCmpLE, AryCmpGT, and AryCmpGE

These instructions compare the values of the elements of two arrays.

- AryCmpLT: Performs a less than comparison.
 AryCmpLE: Performs a less than or equal comparison.
 AryCmpGT: Performs a greater than comparison.
 AryCmpGE: Performs a greater than or equal comparison.

Instruction	Name	FB/FUN	Graphic expression	ST expression
AryCmpLT	Array Comparison Less Than	FUN		AryCmpLT(In1, In2, Size, AryOut);
AryCmpLE	Array Comparison Less Than Or Equal	FUN		AryCmpLE(In1, In2, Size, AryOut);
AryCmpGT	Array Comparison Greater Than	FUN		AryCmpGT(In1, In2, Size, AryOut);
AryCmpGE	Array Comparison Greater Than Or Equal	FUN		AryCmpGE(In1, In2, Size, AryOut);

Variables

Name	Meaning	I/O	Description	Valid range	Unit	Default
In1[] and In2[] (arrays)	Comparison arrays	Input	Arrays containing the elements to compare	Depends on data type.	---	*
Size	Number of comparison elements		Number of elements to compare	Depends on data type.		1
AryOut[] (array)	Comparison results array	In-out	Comparison results array	Depends on data type.	---	---
Out	Return value	Output	Always TRUE	TRUE only	---	---

* If you omit an input parameter, the default value is not applied. A building error will occur.

	Boolean	Bit strings					Integers							Real numbers		Times, durations, dates, and text strings					
	BOOL	BYTE	WORD	DWORD	LWORD	USINT	UINT	UDINT	ULINT	SINT	INT	DINT	LINT	REAL	LREAL	TIME	DATE	TOD	DT	STRING	
In1[] (array)						OK	OK	OK	OK	OK	OK	OK	OK	OK							
In2[] (array)	Must be an array with the same data type as In1[].																				
Size							OK														
AryOut[] (array)	OK																				
Out	OK																				

Function

These instructions compare the values of the elements with the same element numbers in two arrays ($In1[0]$ to $In1[Size - 1]$ and $In2[0]$ and $In2[Size - 1]$). The comparison results are stored in comparison results array *AryOut[]* in the elements with the corresponding element numbers ($AryOut[0]$ to $AryOut[Size - 1]$).

The value of *AryOut[i]* is as follows for each instruction:

Instruction	Value of <i>AryOut[i]</i>
AryCmpLT	If $In1[i] < In2[i]$, the result is TRUE. Otherwise, it is FALSE.
AryCmpLE	If $In1[i] \leq In2[i]$, the result is TRUE. Otherwise, it is FALSE.
AryCmpGT	If $In1[i] > In2[i]$, the result is TRUE. Otherwise, it is FALSE.
AryCmpGE	If $In1[i] \geq In2[i]$, the result is TRUE. Otherwise, it is FALSE.

The following example shows the AryCmpLT instruction when *Size* is UINT#3.

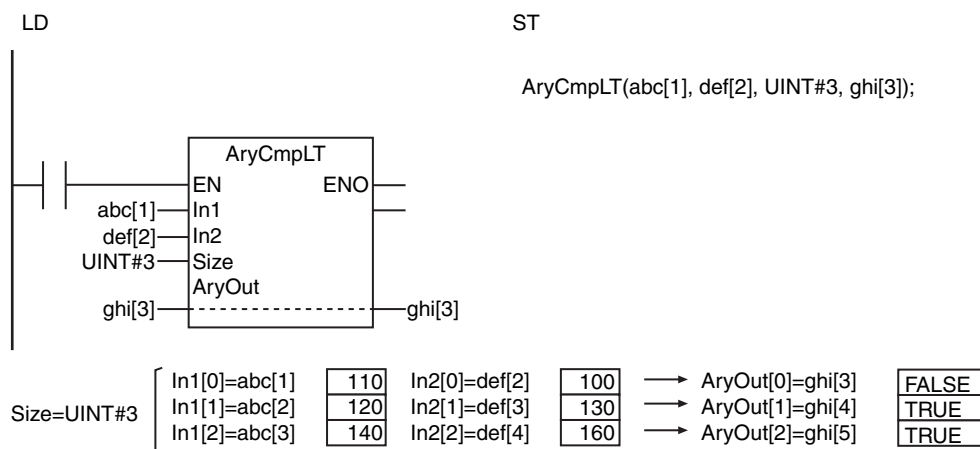

Precautions for Correct Use

- Use the same data type for $In1[]$ and $In2[]$. If they are different, a building error will occur.
- Use an *AryOut[]* array that is at least as large as the value of *Size*.
- If $In1[]$ and $In2[]$ contain real numbers, error may cause unexpected processing results. This can occur, for example, when they contain non-terminating decimal numbers.
- If the value of *Size* is 0, the value of *Out* will be TRUE and *AryOut[]* will not change.
- Return value *Out* is not used when the instruction is used in ST.
- An error occurs in the following cases. *ENO* will be FALSE, and *AryOut[]* will not change.
 - If the $In1[]$, $In2[]$, or *AryOut[]* array is smaller than the value of *Size*.

AryCmpEQV and AryCmpNEV

These instructions compare a value to the values of the elements of an array.

AryCmpEQV: Determines if the elements are equal.

AryCmpNEV: Determines if the elements are not equal.

Instruction	Name	FB/FUN	Graphic expression	ST expression
AryCmpEQV	Array Value Comparison Equal	FUN		AryCmpEQV(In1, In2, Size, AryOut);
AryCmpNEV	Array Value Comparison Not Equal	FUN		AryCmpNEV(In1, In2, Size, AryOut);

Variables

Name	Meaning	I/O	Description	Valid range	Unit	Default
In1[] (array)	Comparison array	Input	Array containing the elements to compare	Depends on data type.	---	*
In2	Comparison value		Value to compare			
Size	Number of comparison elements		Number of elements to compare	Depends on data type.		1
AryOut[] (array)	Comparison results array	In-out	Comparison results array	Depends on data type.	---	---
Out	Return value	Output	Always TRUE	TRUE only	---	---

* If you omit an input parameter, the default value is not applied. A building error will occur.

	Boolean	Bit strings				Integers							Real numbers	Times, durations, dates, and text strings						
	BOOL	BYTE	WORD	DWORD	LWORD	USINT	UINT	UDINT	ULINT	SINT	INT	DINT	LINT	REAL	LREAL	TIME	DATE	TOD	DT	STRING
In1[] (array)	OK	OK	OK	OK	OK	OK	OK	OK	OK	OK	OK	OK	OK	OK						
In2	Must be same data type as the elements of In1[].																			
Size							OK													
AryOut[] (array)	OK																			
Out	OK																			

Function

These instructions compare comparison value $In2$ with the specified elements in an array ($In1[0]$ to $In1[Size - 1]$). The comparison results are stored in comparison results array $AryOut[]$ in the elements with the corresponding element numbers ($AryOut[0]$ to $AryOut[Size - 1]$).

The value of $AryOut[i]$ is as follows for each instruction:

Instruction	Value of $AryOut[i]$
AryCmpEQV	If $In1[i] = In2$, the result is TRUE. Otherwise, it is FALSE.
AryCmpNEV	If $In1[i] \neq In2$, the result is TRUE. Otherwise, it is FALSE.

The following example shows the AryCmpEQV instruction when $In2$ is INT#10 and $Size$ is UINT#3.

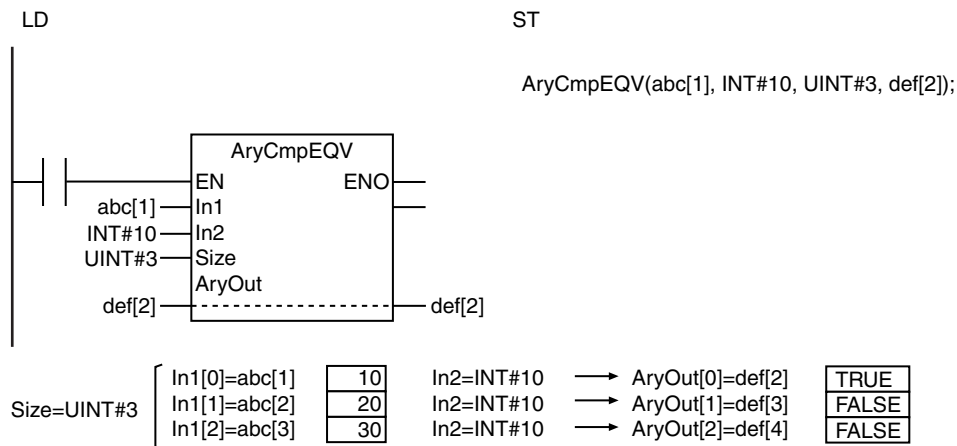

Precautions for Correct Use

- Use the same data type for $In1[]$ and $In2$. If they are different, a building error will occur.
- Use an $AryOut[]$ array that is at least as large as the value of $Size$.
- If $In1[]$ contains real numbers and $In2$ is a real number, error may cause unexpected processing results. This can occur, for example, when they contain non-terminating decimal numbers.
- If the value of $Size$ is 0, the value of Out will be TRUE and $AryOut[]$ will not change.
- Return value Out is not used when the instruction is used in ST.
- An error occurs in the following case. ENO will be FALSE, and $AryOut[]$ will not change.
 - If the $In1[]$ or $AryOut[]$ array is smaller than the value of $Size$.

AryCmpLTV, AryCmpLEV, AryCmpGTV, and AryCmpGEV

These instructions compare a value to the values of the elements of an array.

- AryCmpLTV: Performs a less than comparison.
- AryCmpLEV: Performs a less than or equal comparison.
- AryCmpGTV: Performs a greater than comparison.
- AryCmpGEV: Performs a greater than or equal comparison.

Instruction	Name	FB/FUN	Graphic expression	ST expression
AryCmpLTV	Array Value Comparison Less Than	FUN		AryCmpLTV(In1, In2, Size, AryOut);
AryCmpLEV	Array Value Comparison Less Than Or Equal	FUN		AryCmpLEV(In1, In2, Size, AryOut);
AryCmpGTV	Array Value Comparison Greater Than	FUN		AryCmpGTV(In1, In2, Size, AryOut);
AryCmpGEV	Array Value Comparison Greater Than Or Equal	FUN		AryCmpGEV(In1, In2, Size, AryOut);

Variables

Name	Meaning	I/O	Description	Valid range	Unit	Default
In1[] (array)	Comparison array	Input	Array containing the elements to compare	Depends on data type.	---	*
In2	Comparison value		Value to compare			
Size	Number of comparison elements		Number of elements to compare	Depends on data type.		1
AryOut[] (array)	Comparison results array	In-out	Comparison results array	Depends on data type.	---	---
Out	Return value	Output	Always TRUE	TRUE only	---	---

* If you omit an input parameter, the default value is not applied. A building error will occur.

	Boolean	Bit strings					Integers							Real numbers		Times, durations, dates, and text strings				
	BOOL	BYTE	WORD	DWORD	LWORD	USINT	UINT	UDINT	ULINT	SINT	INT	DINT	LINT	REAL	LREAL	TIME	DATE	TOD	DT	STRING
In1[] (array)						OK	OK	OK	OK	OK	OK	OK	OK	OK						
In2	Must be same data type as the elements of <i>In1[]</i> .																			
Size							OK													
AryOut[] (array)	OK																			
Out	OK																			

Function

These instructions compare comparison value $In2$ with the specified elements in an array ($In1[0]$ to $In1[Size - 1]$). The comparison results are stored in comparison results array $AryOut[]$ in the elements with the corresponding element numbers ($AryOut[0]$ to $AryOut[Size - 1]$).

The value of $AryOut[i]$ is as follows for each instruction:

Instruction	Value of $AryOut[i]$
AryCmpLTV	If $In1[i] < In2$, the result is TRUE. Otherwise, it is FALSE.
AryCmpLEV	If $In1[i] \leq In2$, the result is TRUE. Otherwise, it is FALSE.
AryCmpGTV	If $In1[i] > In2$, the result is TRUE. Otherwise, it is FALSE.
AryCmpGEV	If $In1[i] \geq In2$, the result is TRUE. Otherwise, it is FALSE.

The following example shows the AryCmpLEV instruction when $In2$ is INT#20 and $Size$ is UINT#3.

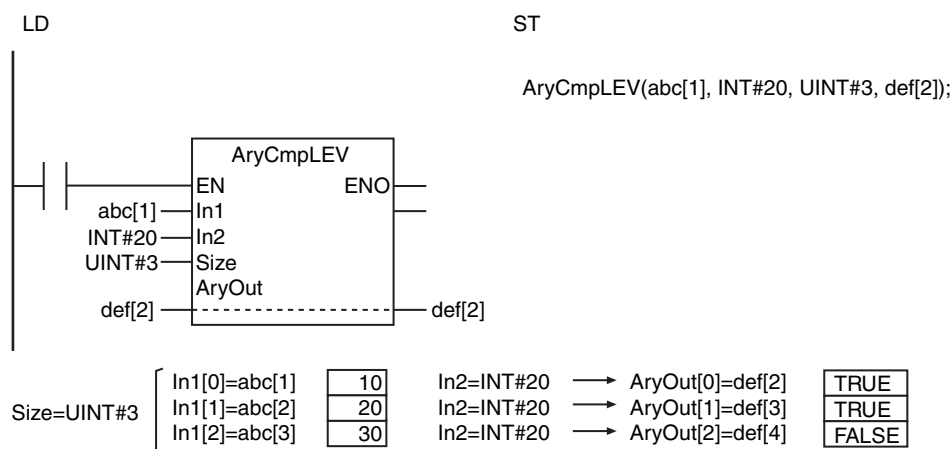

Precautions for Correct Use

- Use the same data type for $In1[]$ and $In2$. If they are different, a building error will occur.
- Use an $AryOut[]$ array that is at least as large as the value of $Size$.
- If $In1[]$ contains real numbers and $In2$ is a real number, error may cause unexpected processing results. This can occur, for example, when they contain non-terminating decimal numbers.
- If the value of $Size$ is 0, the value of Out will be TRUE and $AryOut[]$ will not change.
- Return value Out is not used when the instruction is used in ST.
- An error occurs in the following case. ENO will be FALSE, and $AryOut[]$ will not change.
 - If the $In1[]$ or $AryOut[]$ array is smaller than the value of $Size$.

Timer Instructions

Instruction	Name	Page
TON	On-Delay Timer	2-126
TOF	Off-Delay Timer	2-132
TP	Timer Pulse	2-135
AccumulationTimer	Accumulation Timer	2-138
Timer	Hundred-ms Timer	2-141

TON

The TON instruction outputs TRUE when the set time elapses after the timer starts.

Instruction	Name	FB/FUN	Graphic expression	ST expression
TON	On-Delay Timer	FB		TON_instance (In, PT, Q, ET);

Variables

Name	Meaning	I/O	Description	Valid range	Unit	Default
In	Timer input	Input	TRUE: Timer start signal FALSE: Timer reset signal	Depends on data type.	---	FALSE
PT	Set time		Time from when timer starts until <i>Q</i> changes to TRUE	*	ms	0
Q	Timer output	Output	TRUE: Timer output ON FALSE: Timer output OFF	Depends on data type.	---	---
ET	Elapsed time		Elapsed time since timer started	*	ms	---

* T#0ms to T#106751d_23h_47m_16s_854.775807ms

	Boolean	Bit strings					Integers							Real numbers		Times, durations, dates, and text strings				
	BOOL	BYTE	WORD	DWORD	LWORD	USINT	UINT	UDINT	ULINT	SINT	INT	DINT	LINT	REAL	LREAL	TIME	DATE	TOD	DT	STRING
In	OK																			
PT																OK				
Q	OK																			
ET																OK				

Function

The TON instruction outputs TRUE when the set time elapses after the timer starts. The time is set in nanoseconds. The timer starts when timer input *In* changes to TRUE. Elapsed time *ET* is incremented as time elapses. When *ET* reaches set time *PT*, timer output *Q* changes to TRUE. *ET* is not incremented after that. The timer is reset when *In* changes to FALSE. *ET* changes to 0 and *Q* changes to FALSE.

If the timer is started and then *In* changes to FALSE before *ET* reaches *PT*, the timer is reset.

The following figure shows a programming example and timing chart when *PT* is T#10ms. Variable *abc* will change to TRUE 10 ms after variable *A* changes to TRUE.

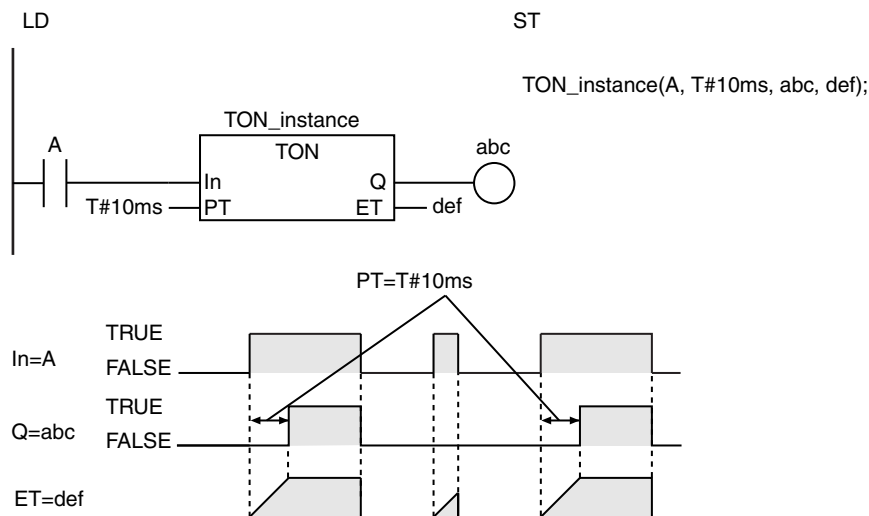

Additional Information

- Use the TP instruction (page 2-135) for a timer that changes the timer output to TRUE when timing starts and then changes the timer output to FALSE when the set time is reached.
- Use the TOF instruction (page 2-132) for a timer that starts when *In* changes to FALSE and then changes the timer output to FALSE when the elapsed time reaches the set time.
- To reduce timer execution time, use the Timer instruction (page 2-141), which times in increments of 100 ms.
- If you are connected to an HMI that does not support TIME data, you must convert the set time from integer data to TIME data before you input it to this instruction. Use the NanoSecToTime instruction (page 2-636) to convert integer data to TIME data. Use the TimeToNanoSec instruction (page 2-634) to convert TIME data to integer data. Both instructions express the time in nanoseconds. The user programming for when the INT variable *msIntVar* is the set time in milliseconds is given below.

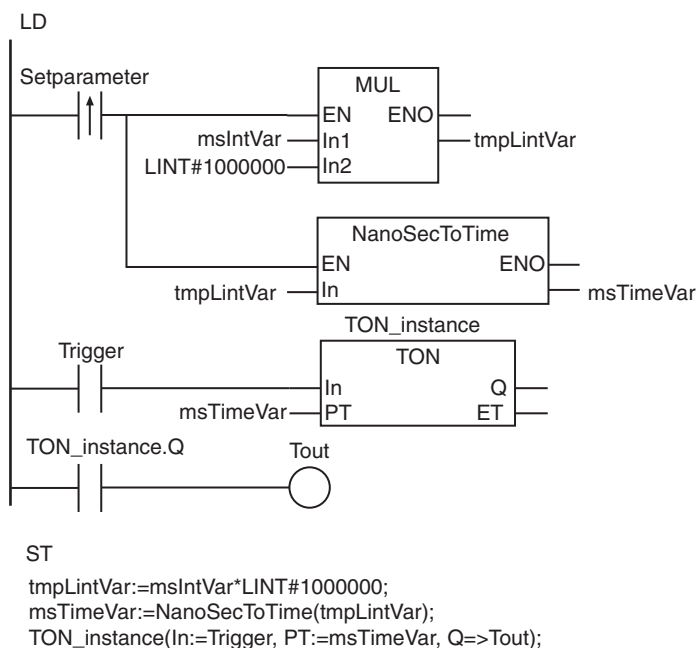

Precautions for Correct Use

- The timing error for which Q is TRUE for PT is -100 ns to $(100$ ns + 1 task period). The above range includes the following:
 - The ± 100 ns is the timing error of ET .
 - Time ET is judged to see if it has reached PT every task period. If time ET reaches PT immediately after the judgement is completed, there is a delay of one task period.
- The time is displayed in increments of 0.001 ms on the Sysmac Studio, but the timing accuracy is 1 ns.
- The timer starts as soon as operation starts if In is already TRUE.
- If $T\#0$ ms or a negative number is set for PT , Q will change to TRUE as soon as the value of In changes to TRUE.
- You can change the value of PT while the value of In is TRUE. Operation is as follows:

Timer status	Value of Q	Value of PT after it is changed	Operation
After completion of timing	TRUE	---	The value of Q remains TRUE. The value of ET also does not change. (It remains at the value of PT before it was changed.)
Timing in progress	FALSE	$PT \geq ET$	Timing is continued. When the value of ET reaches the value of PT , the value of Q changes to TRUE and ET is no longer incremented.
		$PT < ET$	The value of Q changes to TRUE immediately. Incrementing ET stops immediately.

- If this instruction is in a master control region and the master control region is reset, the timer is reset. The value of ET changes to 0 and the value of Q changes to FALSE.
- If this instruction is not executed due to the execution of a jump instruction (e.g., the JMP instruction), the value of ET is not updated. However, timing still continues. Therefore, ET is updated to the correct value the next time the instruction is executed.
- If this instruction is used in a ladder diagram, the value of Q changes to FALSE if an error occurs in the previous instruction on the rung.

Sample Programming

● Measuring Time with One On-Delay Timer

The value of *TimeUp* will change to TRUE 1 second after the value of *Trigger* changes to TRUE.

LD

Variable	Data type	Initial value	Comment
Trigger	BOOL	FALSE	Execution condition
TimeUp	BOOL	FALSE	Timer output
TON_instance	TON		

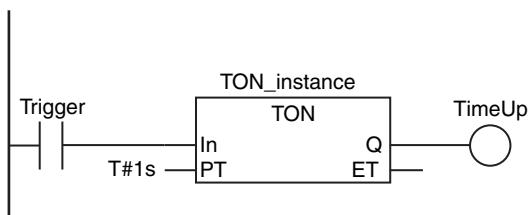

ST

Variable	Data type	Initial value	Comment
Trigger	BOOL	FALSE	Execution condition
TimeUp	BOOL	FALSE	Timer output
TON_instance	TON		

```
IF (Trigger=TRUE) THEN
    TON_instance(In:=TRUE, PT:=T#1s, Q=>TimeUp);
ELSE
    TON_instance(In:=FALSE, Q=>TimeUp);
END_IF;
```

The following ST programming performs the same operation.

ST

Variable	Data type	Initial value	Comment
Trigger	BOOL	FALSE	Execution condition
TimeUp	BOOL	FALSE	Timer output
TON_instance	TON		

```
TON_instance(In:=Trigger, PT:=T#1s, Q=>TimeUp);
```

● **Measuring Time with Multiple On-Delay Timers**

In this example, a total of 100 instances of the On-Delay Timer instruction, TON_instance[0] to TON_instance[99], are programmed. Each timer starts when the value of the corresponding timer input *Input[0]* to *Input[99]* changes to TRUE.

The timers for the first 10 instances, TON_instance[0] to TON_instance[9], change the corresponding values in *TimeUp[i]* to TRUE *i*+1 seconds (*i* = 0 to 9) after execution is started.

The timers for the remaining 90 instances, TON_instance[10] to TON_instance[99], change the corresponding values in *TimeUp[i]* (*i* = 10 to 99) to TRUE as soon as execution is started.

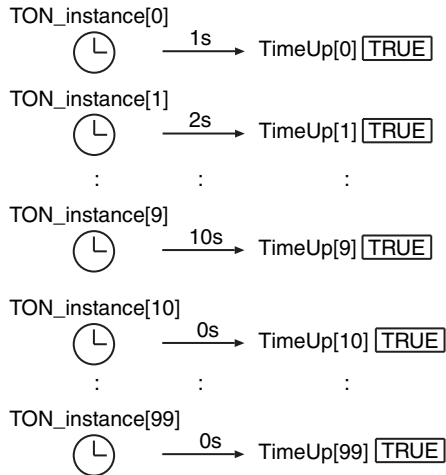

LD

Variable	Data type	Initial value	Comment
Input	ARRAY[0..99] OF BOOL	[100(FALSE)]	Timer input
TimeUp	ARRAY[0..99] OF BOOL	[100(FALSE)]	Timer output
TimePT	ARRAY[0..99] OF TIME	[T#1s, T#2s, T#3s, T#4s, T#5s, T#6s, T#7s, T#8s, T#9s, T#10s, 90(T#0s)]	Set time
TON_instance	ARRAY[0..99] OF TON		
i	UINT	0	Index

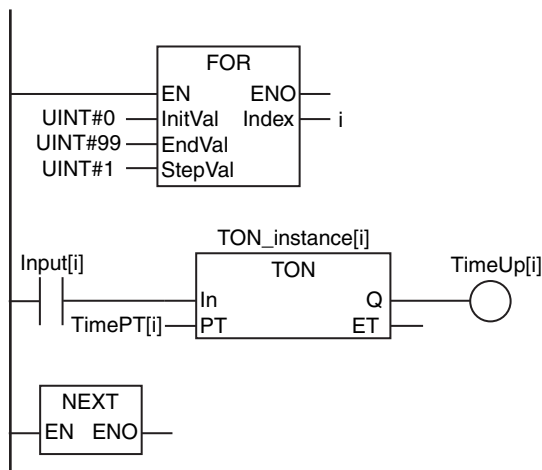

ST

Variable	Data type	Initial value	Comment
Input	ARRAY[0..99] OF BOOL	[100(FALSE)]	Timer input
TimeUp	ARRAY[0..99] OF BOOL	[100(FALSE)]	Timer output
TimePT	ARRAY[0..99] OF TIME	[T#1s, T#2s, T#3s, T#4s, T#5s, T#6s, T#7s, T#8s, T#9s, T#10s, 90(T#0s)]	Set time
TON_instance	ARRAY[0..99] OF TON		
i	UINT	0	Index

```

FOR i :=UINT#0 TO UINT#99 DO
  TON_instance[i] (
    In := Input[i],
    PT := TimePT[i],
    Q  =>TimeUp[i]);
END_FOR;

```

TOF

The TOF instruction outputs FALSE when the set time elapses after the timer starts.

Instruction	Name	FB/FUN	Graphic expression	ST expression
TOF	Off-Delay Timer	FB		TOF_instance (In, PT, Q, ET);

Variables

Name	Meaning	I/O	Description	Valid range	Unit	Default
In	Timer input	Input	TRUE: Timer reset signal FALSE: Timer start signal	Depends on data type.	---	FALSE
PT	Set time		Time from when timer starts until <i>Q</i> changes to FALSE	*	ms	0
Q	Timer output	Output	TRUE: Timer output ON FALSE: Timer output OFF	Depends on data type.	---	---
ET	Elapsed time		Elapsed time since timer started	*	ms	---

* T#0ms to T#106751d_23h_47m_16s_854.775807ms

	Boolean	Bit strings					Integers							Real numbers		Times, durations, dates, and text strings				
	BOOL	BYTE	WORD	DWORD	LWORD	USINT	UINT	UDINT	ULINT	SINT	INT	DINT	LINT	REAL	LREAL	TIME	DATE	TOD	DT	STRING
In	OK																			
PT																OK				
Q	OK																			
ET																OK				

Function

The TOF instruction outputs FALSE when the set time elapses after the timer starts. The time is set in nanoseconds. The timer starts when timer input *In* changes to FALSE. Elapsed time *ET* is incremented as time elapses. When *ET* reaches set time *PT*, timer output *Q* changes to FALSE. *ET* is not incremented after that. The timer is reset when *In* changes to TRUE. *ET* changes to 0 and *Q* changes to TRUE.

If the timer is started and then *In* changes to FALSE before *ET* reaches *PT*, the timer is reset.

The following figure shows a programming example and timing chart for a *PT* of T#10ms. Variable *abc* will change to FALSE 10 ms after variable *A* changes to FALSE.

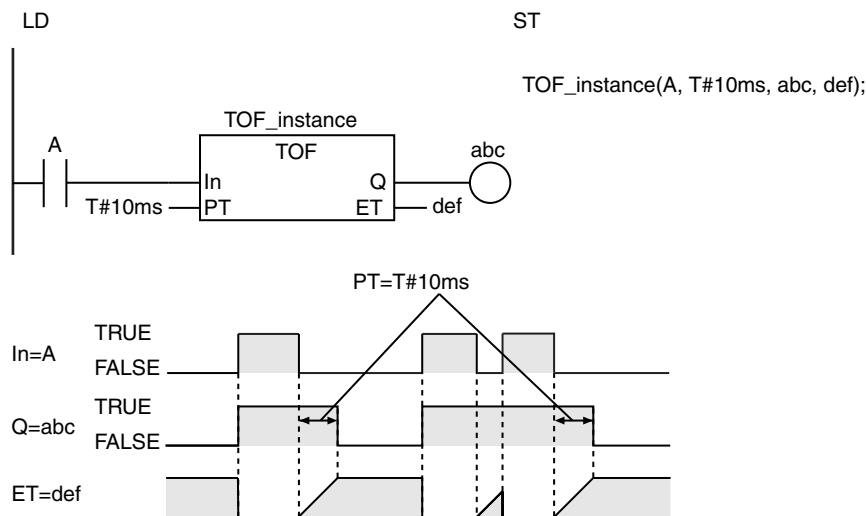

Additional Information

- Use the TP instruction (page 2-135) for a timer that changes the timer output to TRUE when timing starts and then changes the timer output to FALSE when the set time is reached.
- Use the TON instruction (page 2-126) for a timer that starts when *In* changes to TRUE and then changes the timer output to TRUE when the elapsed time reaches the set time.
- If you are connected to an HMI that does not support TIME data, you must convert the set time from integer data to TIME data before you input it to this instruction. Use the NanoSecToTime instruction (page 2-636) to convert integer data to TIME data. Use the TimeToNanoSec instruction (page 2-634) to convert TIME data to integer data. Both instructions express the time in nanoseconds. The user programming for when the INT variable *msIntVar* is the set time in milliseconds is given below.

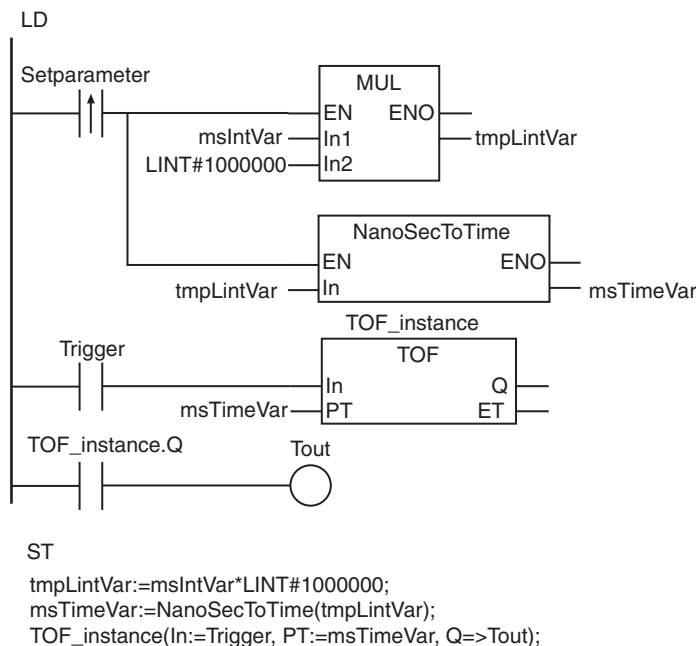

Precautions for Correct Use

- The timing error for which Q is TRUE for PT is -100 ns to $(100$ ns + 1 task period). The above range includes the following:
 - The ± 100 ns is the timing error of ET .
 - Time ET is judged to see if it has reached PT every task period. If time ET reaches PT immediately after the judgement is completed, there is a delay of one task period.
- The time is displayed in increments of 0.001 ms on the Sysmac Studio, but the timing accuracy is 1 ns.
- If $T\#0$ ms or a negative number is set for PT , Q will change to FALSE as soon as the value of In changes to FALSE.
- The value of Q changes to TRUE immediately after execution of this instruction regardless of the value of In . Q is FALSE from only when the timer is started until the time that is set with PT elapses.
- You can change the value of PT while the value of In is FALSE. Operation is as follows:

Timer status	Value of Q	Value of PT after it is changed	Operation
After completion of timing	FALSE	---	The value of Q remains FALSE. The value of ET also does not change. (It remains at the value of PT before it was changed.)
Timing in progress	TRUE	$PT \geq ET$	Timing is continued. When the value of ET reaches the value of PT , the value of Q changes to FALSE and ET is no longer incremented.
		$PT < ET$	The value of Q changes to FALSE immediately. Incrementing ET stops immediately.

- If this instruction is in a master control region and the master control region is reset, the operation is as follows:
 - The value of ET changes to 0 and the value of Q changes to TRUE.
 - If an Out instruction is connected to Q , the execution condition to the Out instruction is FALSE.
 - Timing starts as soon as the reset is released.
- If this instruction is not executed due to the execution of a jump instruction (e.g., the JMP instruction), the value of ET is not updated. However, timing still continues. Therefore, ET is updated to the correct value the next time the instruction is executed.
- If this instruction is used in a ladder diagram, the value of Q changes to FALSE if an error occurs in the previous instruction on the rung.

TP

The TP instruction outputs TRUE while the set time elapses after the timer starts.

Instruction	Name	FB/FUN	Graphic expression	ST expression
TP	Timer Pulse	FB	<pre> graph LR subgraph TP_instance [TP_instance] In --- TP PT --- TP TP --- Q TP --- ET end </pre>	TP_instance (In, PT, Q, ET);

Variables

Name	Meaning	I/O	Description	Valid range	Unit	Default
In	Timer input	Input	TRUE: Timer start signal FALSE: Timer reset signal	Depends on data type.	---	FALSE
PT	Set time		Time that Q remains at TRUE	*	ms	0
Q	Timer output	Output	TRUE: Timer output ON FALSE: Timer output OFF	Depends on data type.	---	---
ET	Elapsed time		Elapsed time since timer started	*	ms	---

* T#0ms to T#106751d_23h_47m_16s_854.775807ms

	Boolean	Bit strings				Integers							Real numbers		Times, durations, dates, and text strings					
	BOOL	BYTE	WORD	DWORD	LWORD	USINT	UINT	UDINT	ULINT	SINT	INT	DINT	LINT	REAL	LREAL	TIME	DATE	TOD	DT	STRING
In	OK																			
PT																OK				
Q	OK																			
ET																OK				

Function

The TP instruction outputs TRUE while the set time elapses after the timer starts. The time is set in nanoseconds. The timer starts when timer input *In* changes to TRUE and timer output *Q* changes to TRUE. Elapsed time *ET* is incremented as time elapses. When *ET* reaches set time *PT*, timer output *Q* changes to FALSE. *ET* is not incremented after that. The timer is reset when *In* changes to FALSE. *ET* changes to 0. The timer is not reset even if *In* changes to FALSE after the timer starts but before *ET* reaches *PT*.

The following figure shows a programming example and timing chart for a *PT* of T#10ms. Variable *abc* changes to TRUE as soon as variable *A* changes to TRUE. Variable *abc* changes to FALSE 10 ms later.

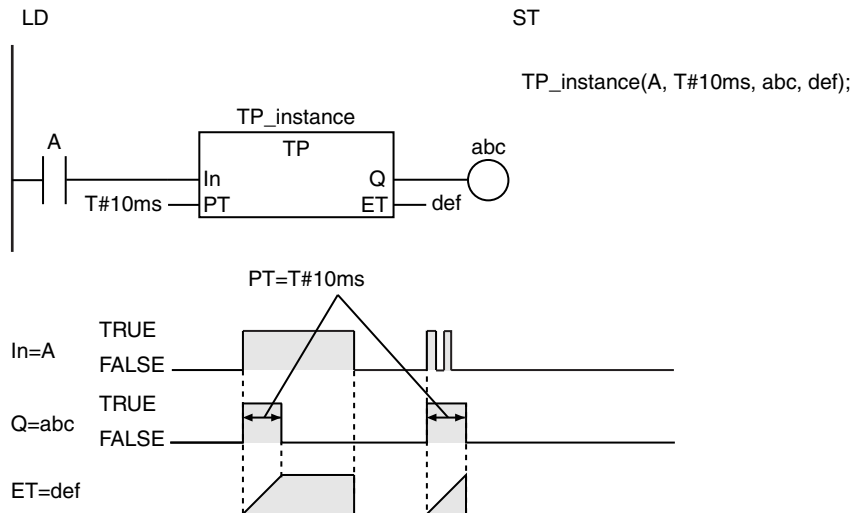

Additional Information

- Use the TON instruction (page 2-126) for a timer that starts when *In* changes to TRUE and then changes the timer output to TRUE when the elapsed time reaches the set time.
- Use the TOF instruction (page 2-132) for a timer that starts when *In* changes to FALSE and then changes the timer output to FALSE when the elapsed time reaches the set time.
- If you are connected to an HMI that does not support TIME data, you must convert the set time from integer data to TIME data before you input it to this instruction. Use the NanoSecToTime instruction (page 2-636) to convert integer data to TIME data. Use the TimeToNanoSec instruction (page 2-634) to convert TIME data to integer data. Both instructions express the time in nanoseconds. The user programming for when the INT variable *msIntVar* is the set time in milliseconds is given below.

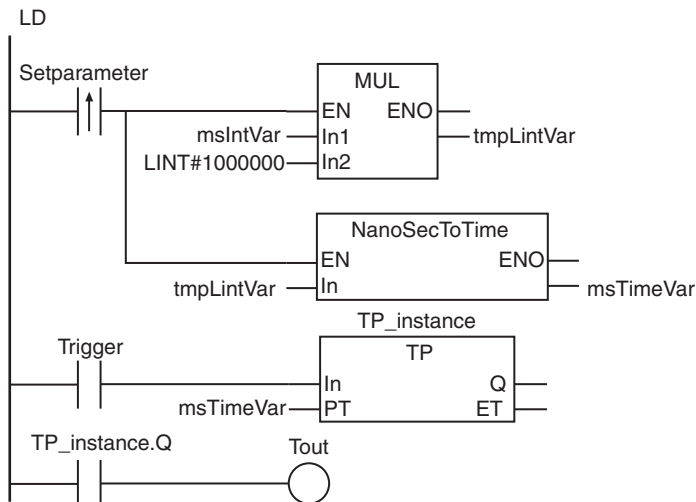

ST

```
tmpLintVar:=msIntVar*LINT#1000000;
msTimeVar:=NanoSecToTime(tmpLintVar);
TP_instance(In:=Trigger, PT:=msTimeVar, Q=>Tout);
```

Precautions for Correct Use

- The timing error for which Q is TRUE for PT is -100 ns to $(100$ ns + 1 task period). The above range includes the following:
 - The ± 100 ns is the timing error of ET .
 - Time ET is judged to see if it has reached PT every task period. If time ET reaches PT immediately after the judgement is completed, there is a delay of one task period.
- The time is displayed in increments of 0.001 ms on the Sysmac Studio, but the timing accuracy is 1 ns.
- The timer starts as soon as operation starts if In is already TRUE.
- If $T\#0$ ms or a negative number is set for PT , Q will not change to TRUE even if the value of In changes to TRUE.
- You can change the value of PT while the value of In is TRUE. Operation is as follows:

Timer status	Value of Q	Value of PT after it is changed	Operation
After completion of timing	FALSE	---	The value of Q remains FALSE. The value of ET also does not change. (It remains at the value of PT before it was changed.)
Timing in progress	TRUE	$PT \geq ET$	Timing is continued. When the value of ET reaches the value of PT , the value of Q changes to FALSE and ET is no longer incremented.
		$PT < ET$	The value of Q changes to FALSE immediately. Incrementing ET stops immediately.

- If this instruction is in a master control region and the master control region is reset, timing is continued to the end if the timer is operating. Then, the value of ET changes to 0 and the value of Q changes to FALSE. However, if an Out instruction is connected to Q , the execution condition to the Out instruction is FALSE even if the value of Q is TRUE.
- If this instruction is not executed due to the execution of a jump instruction (e.g., the JMP instruction), the value of ET is not updated and timing is not performed. Timing restarts when the instruction is executed again.
- If this instruction is used in a ladder diagram, the value of Q changes to FALSE if an error occurs in the previous instruction on the rung.

AccumulationTimer

The AccumulationTimer instruction totals the time that the timer input is TRUE.

Instruction	Name	FB/FUN	Graphic expression	ST expression
AccumulationTimer	Accumulation Timer	FB	<pre> graph LR subgraph AccumulationTimer_instance [AccumulationTimer_instance] In --- AccumulationTimer PT --- AccumulationTimer Reset --- AccumulationTimer AccumulationTimer --- Q AccumulationTimer --- ET end </pre>	AccumulationTimer_instance(In, PT, Reset, Q, ET);

Variables

Name	Meaning	I/O	Description	Valid range	Unit	Default
In	Timer input	Input	TRUE: Timer operates FALSE: Timer stops	Depends on data type.	---	FALSE
PT	Set time		Maximum time	*	ms	0
Reset	Reset		TRUE: Timer reset FALSE: Timer not reset	Depends on data type.	---	FALSE
Q	Timer output	Output	TRUE: <i>ET</i> reached <i>PT</i> . FALSE: <i>ET</i> has not reached <i>PT</i> .	Depends on data type.	---	---
ET	Total time		Total time	*	ms	

* T#0ms to T#106751d_23h47m_16s_854.775807ms

	Boolean	Bit strings					Integers							Real numbers		Times, durations, dates, and text strings				
	BOOL	BYTE	WORD	DWORD	LWORD	USINT	UINT	UDINT	ULINT	SINT	INT	DINT	LINT	REAL	LREAL	TIME	DATE	TOD	DT	STRING
In	OK																			
PT																OK				
Reset	OK																			
Q	OK																			
ET																OK				

Function

The AccumulationTimer instruction totals the time that the timer input is TRUE. The time is set in nano-seconds. If reset *Reset* is FALSE, the timer starts when *In* changes to TRUE. Total time *ET* is incremented as time elapses. The timer stops when *In* changes to FALSE. *ET* is held. When *In* changes to TRUE again, the timer starts again. *ET* is incremented from the value that was previously held. When *ET* reaches set time *PT*, timer output *Q* changes to TRUE. *ET* is not incremented after that. The timer is reset when *Reset* changes to TRUE. *ET* changes to 0 and *Q* changes to FALSE.

The following figure shows a programming example and timing chart for a *PT* of T#10ms. Variable *abc* changes to TRUE when variable *A* is TRUE for a total of 10 ms (i.e., the total time).

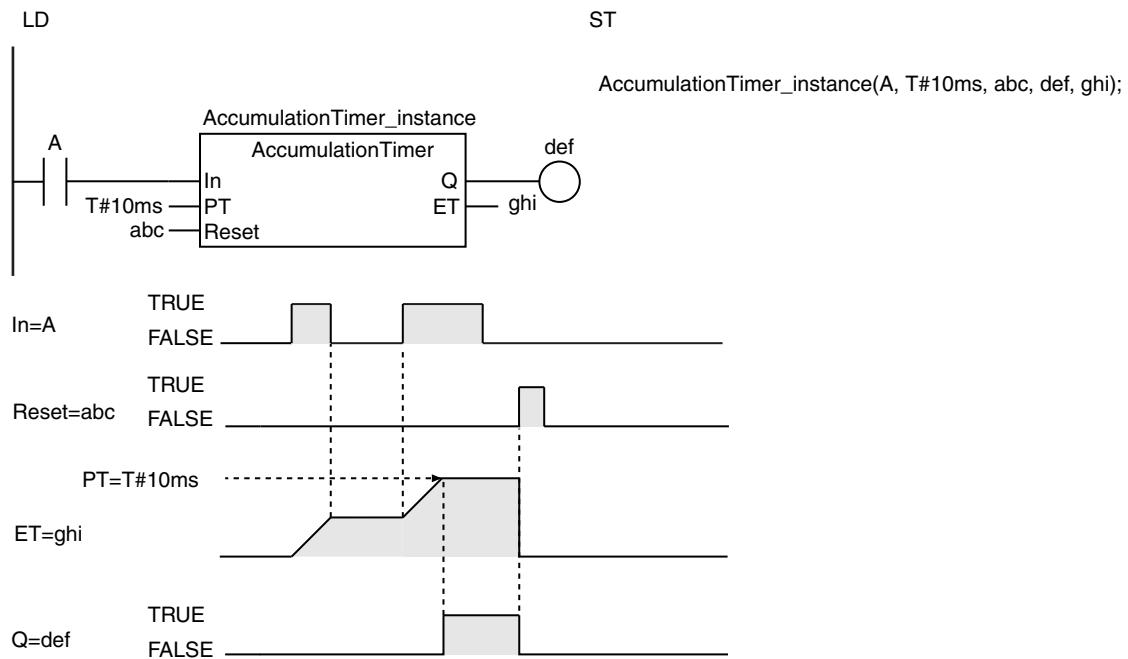

Additional Information

- Use the TON instruction (page 2-126) for a timer that resets the timer output and elapsed time when *In* changes to FALSE.
- If you are connected to an HMI that does not support TIME data, you must convert the set time from integer data to TIME data before you input it to this instruction. Use the NanoSecToTime instruction (page 2-636) to convert integer data to TIME data. Use the TimeToNanoSec instruction (page 2-634) to convert TIME data to integer data. Both instructions express the time in nanoseconds. The user programming for when the INT variable *msIntVar* is the set time in milliseconds is given below.

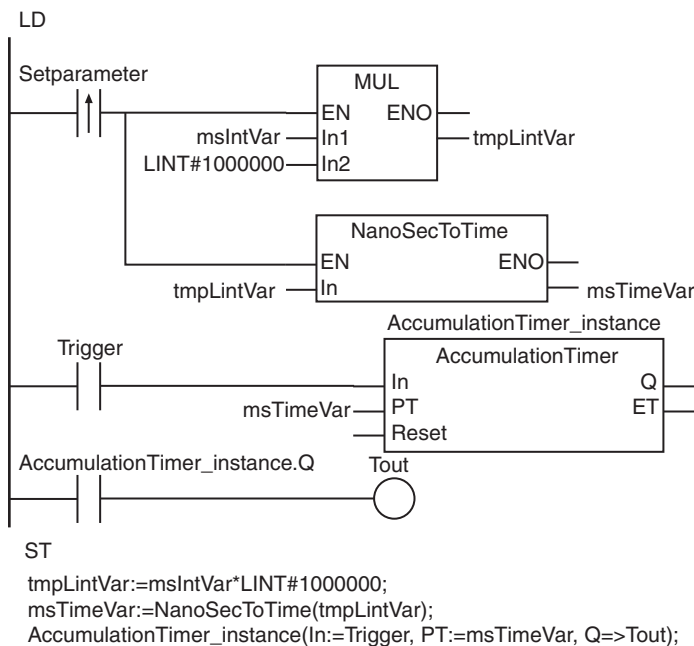

Precautions for Correct Use

- The timing error for which Q is TRUE for PT is -100 ns to $(100$ ns + 1 task period).
The above range includes the following:
 - The ± 100 ns is the timing error of ET .
 - Time ET is judged to see if it has reached PT every task period. If time ET reaches PT immediately after the judgement is completed, there is a delay of one task period.
- The time is displayed in increments of 0.001 ms on the Sysmac Studio, but the timing accuracy is 1 ns.
- If In and $Reset$ are both TRUE, $Reset$ has priority. That is, ET changes to 0 and Q changes to FALSE.
- The timer starts as soon as operation starts if In is already TRUE.
- If $T\#0$ ms or a negative number is set for PT , Q will change to TRUE as soon as the value of In changes to TRUE.
- You can change the value of PT before the value of ET reaches the value of PT . Operation is as follows:

Timer status	Value of Q	Value of PT after it is changed	Operation
After completion of timing	TRUE	---	The value of Q remains TRUE. The value of ET also does not change. (It remains at the value of PT before it was changed.)
Timing in progress	FALSE	$PT \geq ET$	When the value of In changes to TRUE, timing is continued. When the value of ET reaches the value of PT , the value of Q changes to TRUE and ET is no longer incremented.
		$PT < ET$	When the value of In changes to TRUE, the value of Q changes to TRUE immediately. Incrementing ET stops immediately.

- If this instruction is in a master control region and the master control region is reset, the operation is as follows:
 - The timer stops. The values of ET and Q at that time are retained.
 - When the master control reset is cleared, ET is incremented again from the value that was retained.
 - If an Out instruction is connected to Q , the execution condition to the Out instruction is FALSE even if the value of Q is TRUE.
 - $Reset$ is enabled.
- If this instruction is not executed due to the execution of a jump instruction (e.g., the JMP instruction), the value of ET is not updated. However, timing still continues. Therefore, ET is updated to the correct value the next time the instruction is executed.
- If this instruction is used in a ladder diagram, the value of Q changes to FALSE if an error occurs in the previous instruction on the rung.

Timer

The Timer instruction outputs TRUE when the set time elapses after the timer starts. The time is set in increments of 100 ms.

Instruction	Name	FB/FUN	Graphic expression	ST expression
Timer	Hundred-ms Timer	FUN		Out:=Timer (In, PT, TimerDat, Q, ET);

Variables

Name	Meaning	I/O	Description	Valid range	Unit	Default
In	Timer input	Input	TRUE: Timer start specification FALSE: Timer reset specification	Depends on data type.	---	FALSE
PT	Set time		Time from when timer starts until Q changes to TRUE		ms	*
TimerDat	Timer status	In-out	Current status of timer	---	---	---
Out	Return value	Output	TRUE: Make timer output TRUE FALSE: Make timer output FALSE	Depends on data type.	---	---
Q	Timer output		Same meaning as <i>Out</i> .			
ET	Remaining time		Remaining time		ms	

* If you omit an input parameter, the default value is not applied. A building error will occur.

	Boolean	Bit strings					Integers							Real numbers	Times, durations, dates, and text strings						
	BOOL	BYTE	WORD	DWORD	LWORD	USINT	UINT	UDINT	ULINT	SINT	INT	DINT	LINT	REAL	LREAL	TIME	DATE	TOD	DT	STRING	
In	OK																				
PT							OK														
TimerDat	Structure <code>_sTimer</code>																				
Out	OK																				
Q	OK																				
ET							OK														

- If this instruction is not executed due to the execution of a jump instruction (e.g., the JMP instruction), the value of *ET* is not updated. However, timing still continues. Therefore, *ET* is updated to the correct value the next time the instruction is executed.
- If this instruction is used in a ladder diagram, the values of *Q* and *Out* change to FALSE if an error occurs in the previous instruction on the rung.

Counter Instructions

Instruction	Name	Page
CTD	Down-counter	2-146
CTD_**	Down-counter Group	2-148
CTU	Up-counter	2-150
CTU_**	Up-counter Group	2-152
CTUD	Up-down Counter	2-155
CTUD_**	Up-down Counter Group	2-159

CTD

The CTD instruction decrements the counter value when the counter input signal is received. The preset value and counter value must have an INT data type.

Instruction	Name	FB/FUN	Graphic expression	ST expression
CTD	Down-counter	FB		CTD_instance (CD, Load, PV, Q, CV);

Variables

Name	Meaning	I/O	Description	Valid range	Unit	Default
CD	Counter input	Input	Counter input	Depends on data type.	---	FALSE
Load*	Load signal		TRUE: Set CV to PV.			
PV	Preset value		Counter preset value	0 to 32767		0
Q	Counter output	Output	TRUE: Counter output ON FALSE: Counter output OFF	Depends on data type.	---	---
CV	Counter value		Counter present value	0 to 32767		

* On Sysmac Studio version 1.03, you can use “LD” instead of “Load” to more clearly show the correspondence between the variables and the parameter names in ST expressions. For example, you can use the following notation: *CTD_instance (CD:=A, LD:=abc, PV:=INT#5, Q=>def, CV=>ghi);*.

	Boolean	Bit strings					Integers							Real numbers		Times, durations, dates, and text strings				
	BOOL	BYTE	WORD	DWORD	LWORD	USINT	UINT	UDINT	ULINT	SINT	INT	DINT	LINT	REAL	LREAL	TIME	DATE	TOD	DT	STRING
CD	OK																			
Load	OK																			
PV											OK									
Q	OK																			
CV											OK									

Function

The CTD instruction creates a down counter. The preset value and counter value must have an INT data type.

When load signal *Load* changes to TRUE, counter value *CV* is set to the value of preset value *PV* and counter output *Q* changes to FALSE. When counter input signal *CD* changes to TRUE, *CV* is decremented. When the value of *CV* reaches 0 or less, the value of *Q* changes to TRUE.

After the value of *CV* reaches 0 or less, *CV* does not change even if *CD* changes to TRUE.

CD is ignored while *Load* is TRUE. *CV* is not decremented.

The following figure shows a programming example and timing chart for a *PV* of INT#5.

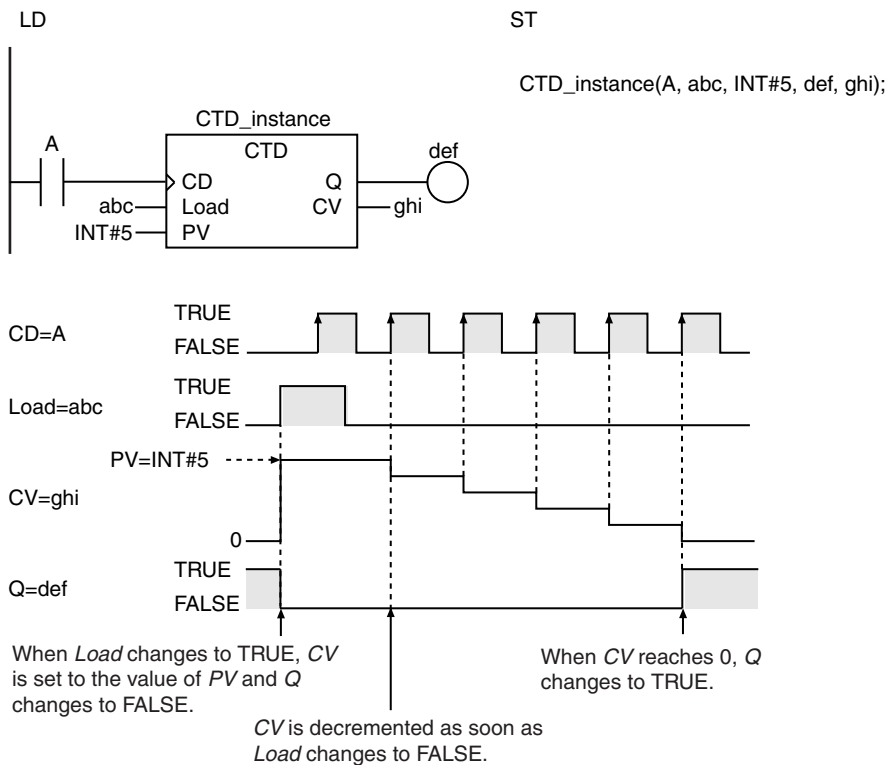

Additional Information

- Use the CTU instruction (page 2-150) to create a counter that increments the counter value each time the counter input signal is received.
- Use the CTUD instruction (page 2-155) to create a counter that is both incremented and decremented.

Precautions for Correct Use

- Change *Load* to TRUE and then back to FALSE to restart a counter that has completed counting down.
- Even when *PV* is set to a negative value, *CV* is set to the value of *PV* when the value of *Load* changes to TRUE. The value of *CV* will be 0 or less, so the value of *Q* changes to TRUE immediately. After that, the value of *CV* is not decremented even if the value of *CD* changes.
- If the value of *CD* is FALSE and the power supply is interrupted or the operating mode is changed to PROGRAM mode, the value of *CV* is decremented once if the value of *CD* is TRUE when instruction execution is restarted.
- If this instruction is used in a ladder diagram, the value of *Q* changes to FALSE if an error occurs in the previous instruction on the rung.

CTD_**

The CTD_** instruction decrements the counter value when the counter input signal is received. The preset value and counter value must be one of the following data types: DINT, LINT, UDINT, or ULINT.

Instruction	Name	FB/FUN	Graphic expression	ST expression
CTD_**	Down-counter Group	FB	<p>*** must be DINT, LINT, UDINT, or ULINT.</p>	CTD_**_instance (CD, Load, PV, Q, CV); *** must be DINT, LINT, UDINT, or ULINT.

Variables

Name	Meaning	I/O	Description	Valid range	Unit	Default
CD	Counter input	Input	Counter input	Depends on data type.	---	FALSE
Load*1	Load signal		TRUE: Set CV to PV.			
PV	Preset value		Counter preset value	Depends on data type.*2		0
Q	Counter output	Output	TRUE: Counter output ON FALSE: Counter output OFF	Depends on data type.	---	---
CV	Counter value		Counter present value	Depends on data type.*2		

*1 On Sysmac Studio version 1.03, you can use “LD” instead of “Load” to more clearly show the correspondence between the variables and the parameter names in ST expressions. For example, you can use the following notation: `CTD_LINT_instance(CD:=A, LD:=abc, PV:=LINT#5, Q=>def, CV=>ghi);`.

*2 Negative numbers are excluded.

	Boolean	Bit string					Integers							Real numbers	Times, durations, dates, and text strings					
	BOOL	BYTE	WORD	DWORD	LWORD	USINT	UINT	UDINT	ULINT	SINT	INT	DINT	LINT	REAL	LREAL	TIME	DATE	TOD	DT	STRING
CD	OK																			
Load	OK																			
PV								OK	OK			OK	OK							
Q	OK																			
CV	Must be the same data type as PV																			

Function

A CTD_** instruction creates a down counter. The preset value and counter value must be one of the following data types: DINT, LINT, UDINT, or ULINT. The name of the instruction is determined by the data type of PV and CV. For example, if they are the CV data type, the instruction is CTD_LINT.

When load signal *Load* changes to TRUE, counter value *CV* is set to the value of preset value *PV* and counter output *Q* changes to FALSE. When counter input signal *CD* changes to TRUE, *CV* is decremented. When the value of *CV* reaches 0 or less, the value of *Q* changes to TRUE.

After the value of *CV* reaches 0 or less, *CV* does not change even if *CD* changes to TRUE.

CD is ignored while *Load* is TRUE. *CV* is not decremented.

The following figure shows a CTD_LINT programming example and timing chart for a *PV* of LINT#5.

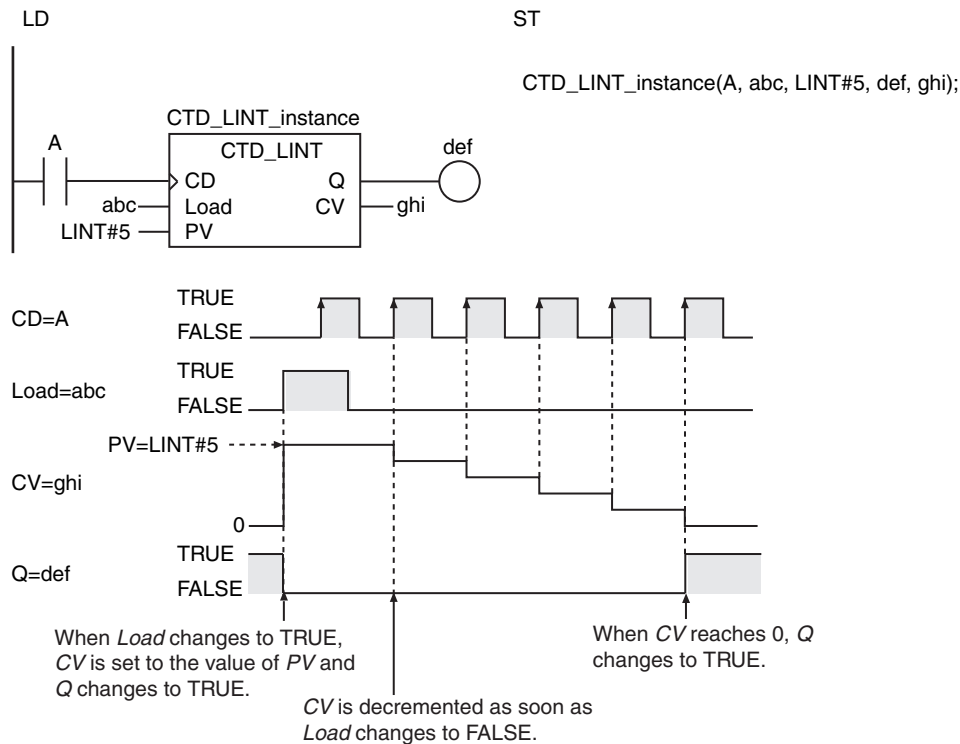

Additional Information

- Use the CTU instruction (page 2-150) to create a counter that increments the counter value each time the counter input signal is received.
- Use the CTUD instruction (page 2-155) to create a counter that is both incremented and decremented.

Precautions for Correct Use

- Change *Load* to TRUE and then back to FALSE to restart a counter that has completed counting down.
- Use the same data type for *PV* and *CV*.
- Even when *PV* is set to a negative value, *CV* is set to the value of *PV* when the value of *Load* changes to TRUE. The value of *CV* will be 0 or less, so the value of *Q* changes to TRUE immediately. After that, the value of *CV* is not decremented even if the value of *CD* changes.
- If the value of *CD* is FALSE and the power supply is interrupted or the operating mode is changed to PROGRAM mode, the value of *CV* is decremented once if the value of *CD* is TRUE when instruction execution is restarted.
- If this instruction is used in a ladder diagram, the value of *Q* changes to FALSE if an error occurs in the previous instruction on the rung.

CTU

The CTU instruction increments the counter value when the counter input signal is received. The preset value and counter value must have an INT data type.

Instruction	Name	FB/FUN	Graphic expression	ST expression
CTU	Up-counter	FB	<pre> graph LR subgraph CTU_instance [CTU_instance] direction TB CU[CU] Reset[Reset] PV[PV] Q[Q] CV[CV] end CU --> CTU_instance Reset --> CTU_instance PV --> CTU_instance CTU_instance --> Q CTU_instance --> CV </pre>	CTU_instance (CU, Reset, PV, Q, CV);

Variables

Name	Meaning	I/O	Description	Valid range	Unit	Default
CU	Counter input	Input	Counter input	Depends on data type.	---	FALSE
Reset*	Reset signal		TRUE: Reset CV to 0.			
PV	Preset value		Counter preset value			
Q	Counter output	Output	TRUE: Counter output ON FALSE: Counter output OFF	Depends on data type.	---	---
CV	Counter value		Counter present value	0 to 32767		

* On Sysmac Studio version 1.03, you can use “R” instead of “Reset” to more clearly show the correspondence between the variables and the parameter names in ST expressions. For example, you can use the following notation: *CTU_instance (CU:=A, R:=abc, PV:=INT#5, Q=>def, CV=>ghi);*

	Boolean	Bit strings					Integers							Real numbers		Times, durations, dates, and text strings				
	BOOL	BYTE	WORD	DWORD	LWORD	USINT	UINT	UDINT	ULINT	SINT	INT	DINT	LINT	REAL	LREAL	TIME	DATE	TOD	DT	STRING
CU	OK																			
Reset	OK																			
PV											OK									
Q	OK																			
CV											OK									

Function

The CTU instruction creates an up counter. The preset value and counter value must have an INT data type.

When reset signal *Reset* changes to TRUE, counter value *CV* changes to 0 and counter output *Q* changes to FALSE. When counter input signal *CU* changes to TRUE, *CV* is incremented. When the value of *CV* reaches the value of *PV* or higher, the value of *Q* changes to TRUE.

After the value of *CV* reaches the value of *PV* or higher, the value of *CV* does not change even if the value of *CU* changes to TRUE.

CU is ignored while *Reset* is TRUE. *CV* is not incremented.

The following figure shows a programming example and timing chart for a *PV* of INT#5.

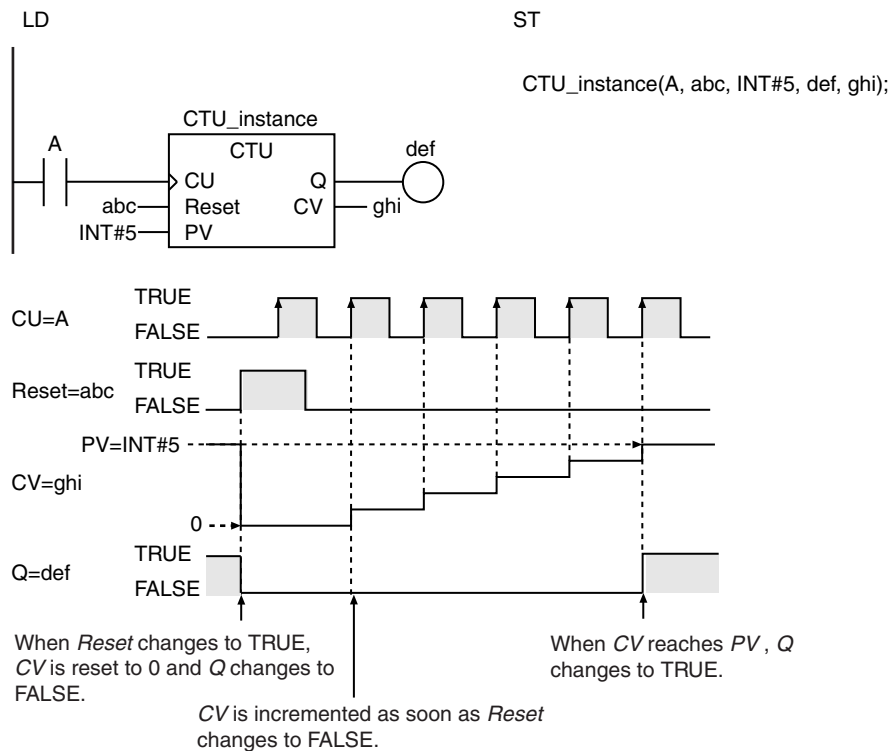

Additional Information

- Use the CTD instruction (page 2-146) to create a counter that decrements the counter value each time the counter input signal is received.
- Use the CTUD instruction (page 2-155) to create a counter that is both incremented and decremented.

Precautions for Correct Use

- Change *Reset* to TRUE and then back to FALSE to restart a counter that has completed counting up.
- Even when *PV* is set to a negative value, *CV* is set to 0 when the value of *Reset* changes to TRUE. The value of *CV* will be higher than the value of *PV*, so the value of *Q* changes to TRUE immediately. After that, the value of *CV* is not incremented even if the value of *CU* changes.
- The following operation is performed if the value of *PV* changes while the value of *Reset* is FALSE.

Value of <i>PV</i>	Meaning
Larger than the current value of <i>CV</i>	The count operation is continued.
Equal to or smaller than the current value of <i>CV</i>	The count operation is ended. The value of <i>Q</i> changes to TRUE. The current value of <i>CV</i> is retained. It does not change.

- If the value of *CU* is FALSE and the power supply is interrupted or the operating mode is changed to PROGRAM mode, the value of *CV* is incremented once if the value of *CU* is TRUE when instruction execution is restarted.
- If this instruction is used in a ladder diagram, the value of *Q* changes to FALSE if an error occurs in the previous instruction on the rung.

CTU_**

The CTU_** instruction increments the counter value when the counter input signal is received. The preset value and counter value must be one of the following data types: DINT, LINT, UDINT, or ULINT.

Instruction	Name	FB/FUN	Graphic expression	ST expression
CTU_**	Up-counter Group	FB	<p>CTU_**_instance</p> <p>CU Q</p> <p>Reset CV</p> <p>PV</p> <p>**** must be DINT, LINT, UDINT, or ULINT.</p>	CTU_**_instance (CU, Reset, PV, Q, CV); **** must be DINT, LINT, UDINT, or ULINT.

Variables

Name	Meaning	I/O	Description	Valid range	Unit	Default
CU	Counter input	Input	Counter input	Depends on data type.	---	FALSE
Reset*1	Reset signal		TRUE: Reset CV to 0.			
PV	Preset value		Counter preset value	Depends on data type.*2		0
Q	Counter output	Output	TRUE: Counter output ON FALSE: Counter output OFF	Depends on data type.	---	---
CV	Counter value		Counter present value	Depends on data type.*2		

*1 On Sysmac Studio version 1.03, you can use "R" instead of "Reset" to more clearly show the correspondence between the variables and the parameter names in ST expressions. For example, you can use the following notation: `CTU_LINT_instance(CU:=A, R:=abc, PV:=LINT#5, Q=>def, CV=>ghi);`.

*2 Negative numbers are excluded.

	Boolean	Bit strings					Integers							Real numbers		Times, durations, dates, and text strings				
	BOOL	BYTE	WORD	DWORD	LWORD	USINT	UINT	UDINT	ULINT	SINT	INT	DINT	LINT	REAL	LREAL	TIME	DATE	TOD	DT	STRING
CU	OK																			
Reset	OK																			
PV								OK	OK			OK	OK							
Q	OK																			
CV	Must be the same data type as PV																			

Function

A CTU_** instruction creates an up counter. The preset value and counter value must be one of the following data types: DINT, LINT, UDINT, or ULINT. The name of the instruction is determined by the data type of PV and CV. For example, if they are the LINT data type, the instruction is CTU_LINT.

When reset signal *Reset* changes to TRUE, counter value *CV* changes to 0 and counter output *Q* changes to FALSE. When counter input signal *CU* changes to TRUE, *CV* is incremented. When the value of *CV* reaches the value of *PV* or higher, the value of *Q* changes to TRUE.

After the value of *CV* reaches the value of *PV* or higher, the value of *CV* does not change even if the value of *CU* changes to TRUE.

CU is ignored while *Reset* is TRUE. *CV* is not incremented.

The following figure shows a CTU_LINT programming example and timing chart for a *PV* of LINT#5.

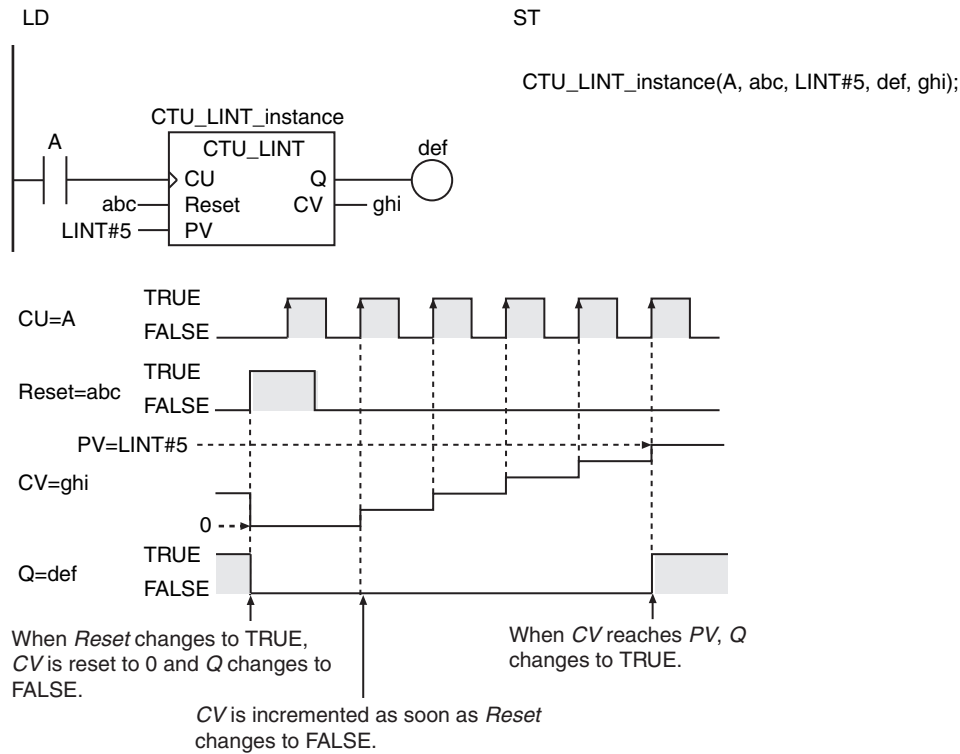

Additional Information

- Use the CTD instruction (page 2-146) to create a counter that decrements the counter value each time the counter input signal is received.
- Use the CTUD instruction (page 2-155) to create a counter that is both incremented and decremented.

Precautions for Correct Use

- Change *Reset* to TRUE and then back to FALSE to restart a counter that has completed counting up.
- Even when *PV* is set to a negative value, *CV* is set to 0 when the value of *Reset* changes to TRUE. The value of *CV* will be higher than the value of *PV*, so the value of *Q* changes to TRUE immediately. After that, the value of *CV* is not incremented even if the value of *CU* changes.
- Use the same data type for *PV* and *CV*.
- The following operation is performed if the value of *PV* changes while the value of *Reset* is FALSE.

Value of <i>PV</i>	Meaning
Larger than the current value of <i>CV</i>	The count operation is continued.
Equal to or smaller than the current value of <i>CV</i>	The count operation is ended. The value of <i>Q</i> changes to TRUE. The current value of <i>CV</i> is retained. It does not change.

- If the value of *CU* is FALSE and the power supply is interrupted or the operating mode is changed to PROGRAM mode, the value of *CV* is incremented once if the value of *CU* is TRUE when instruction execution is restarted.

- If this instruction is used in a ladder diagram, the value of Q changes to FALSE if an error occurs in the previous instruction on the rung.

CTUD

The CTUD instruction creates an up-down counter that operates according to an up-counter input and a down-counter input. The preset value and counter value must have an INT data type.

Instruction	Name	FB/FUN	Graphic expression	ST expression
CTUD	Up-down Counter	FB		CTUD_instance (CU, CD, Reset, Load, PV, QU, QD, CV);

Variables

Name	Meaning	I/O	Description	Valid range	Unit	Default
CU	Up-counter input	Input	Up counter input	Depends on data type.	---	FALSE
CD	Down-counter input		Down counter input			
Reset*	Reset signal		TRUE: Reset CV to 0.			
Load*	Load signal		TRUE: CV set to PV.			
PV	Preset value		The final counter value when operating as an up counter The initial counter value when operating as a down counter			
QU	Up-counter output	Output	TRUE: up-counter output ON FALSE: up-counter output OFF	Depends on data type.	---	---
QD	Down-counter output		TRUE: down-counter output ON FALSE: down-counter output OFF			
CV	Counter value		Counter present value			

* On Sysmac Studio version 1.03, you can use "R" instead of "Reset" and "LD" instead of "Load" to more clearly show the correspondence between the variables and the parameter names in ST expressions. For example, you can use the following notation: `CTUD_instance(CU:=A, CD:=B, R:=abc, LD:=def, PV:=INT#3, QU=>ghi, QD=>jkl, CV=>mno);`

	Boolean	Bit string					Integers							Real numbers		Times, durations, dates, and text strings				
	BOOL	BYTE	WORD	DWORD	LWORD	USINT	UINT	UDINT	ULINT	SINT	INT	DINT	LINT	REAL	LREAL	TIME	DATE	TOD	DT	STRING
CU	OK																			
CD	OK																			
Reset	OK																			
Load	OK																			
PV										OK										
QU	OK																			
QD	OK																			
CV										OK										

Function

The CTUD instruction creates an up-down counter that operates according to an up-counter input signal and a down-counter input signal. It has the functions of both an up counter and a down counter. The preset value and counter value must have an INT data type.

Operation as an Up Counter

When reset signal *Reset* changes to TRUE, counter value *CV* changes to 0 and up-counter output *QU* changes to FALSE. When up-counter input signal *CU* changes to TRUE, *CV* is incremented. When the value of *CV* reaches the value of *PV* or higher, the value of *QU* changes to TRUE. After the value of *CV* reaches the value of *PV* or higher, the value of *CV* does not change even if the value of *CU* changes to TRUE.

Operation as a Down Counter

When load signal *Load* changes to TRUE, counter value *CV* changes to the value of preset value *PV* and down-counter output *QD* changes to FALSE. When down-counter input signal *CD* changes to TRUE, *CV* is decremented. When the value of *CV* reaches 0 or less, the value of *QD* changes to TRUE. After the value of *CV* reaches 0 or less, *CV* does not change even if *CD* changes to TRUE.

Common Operation for Up and Down Counters

CU and *CD* are ignored while *Load* and *Reset* are TRUE. *CV* is not incremented or decremented. If both *CU* and *CD* change to TRUE at the same time, *CV* will not change. If *Reset* and *Load* are both TRUE, *Reset* has priority and the value of *CV* changes to 0. If *Reset* changes to TRUE, *CV* changes to 0, and so *QD* changes to TRUE. If *Load* changes to TRUE, the value of *CV* changes to *PV*, and so *QU* changes to TRUE.

The following table shows the relationship between *Reset*, *Load*, *CV*, *QU*, and *QD*. This assumes that the value of *PV* is larger than 0.

<i>Reset</i>	<i>Load</i>	<i>CV</i>	<i>QU</i>	<i>QD</i>	Operation
FALSE	FALSE	0 or lower	FALSE	TRUE	Only up counter operation is performed. <ul style="list-style-type: none"> <i>CV</i> is incremented when <i>CU</i> changes to TRUE. It is not decremented when <i>CD</i> changes to TRUE.
		Between 0 and <i>PV</i>	FALSE	FALSE	Both up and down counter operation is performed. <ul style="list-style-type: none"> <i>CV</i> is incremented when <i>CU</i> changes to TRUE and decremented when <i>CD</i> changes to TRUE.
		<i>PV</i> or higher	TRUE	FALSE	Only down counter operation is performed. <ul style="list-style-type: none"> <i>CV</i> is decremented when <i>CD</i> changes to TRUE. It is not incremented when <i>CU</i> changes to TRUE.
TRUE	FALSE	0	FALSE	TRUE	The up counter is reset. <ul style="list-style-type: none"> The value of <i>CV</i> is set to 0.
FALSE	TRUE	<i>PV</i>	TRUE	FALSE	The down counter is reset. <ul style="list-style-type: none"> The value of <i>CV</i> is set to <i>PV</i>.
TRUE	TRUE	0	FALSE	TRUE	The up counter is reset. <i>Reset</i> take priority over <i>Load</i> . <ul style="list-style-type: none"> The value of <i>CV</i> is set to 0.

The following figure shows a programming example and timing chart for a *PV* of INT#3.

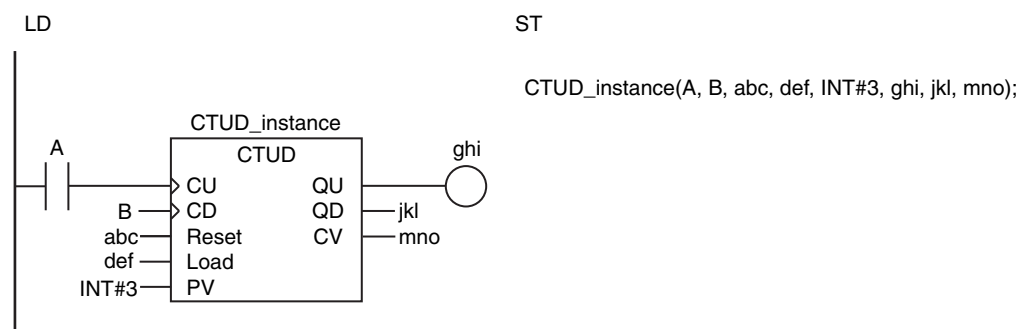

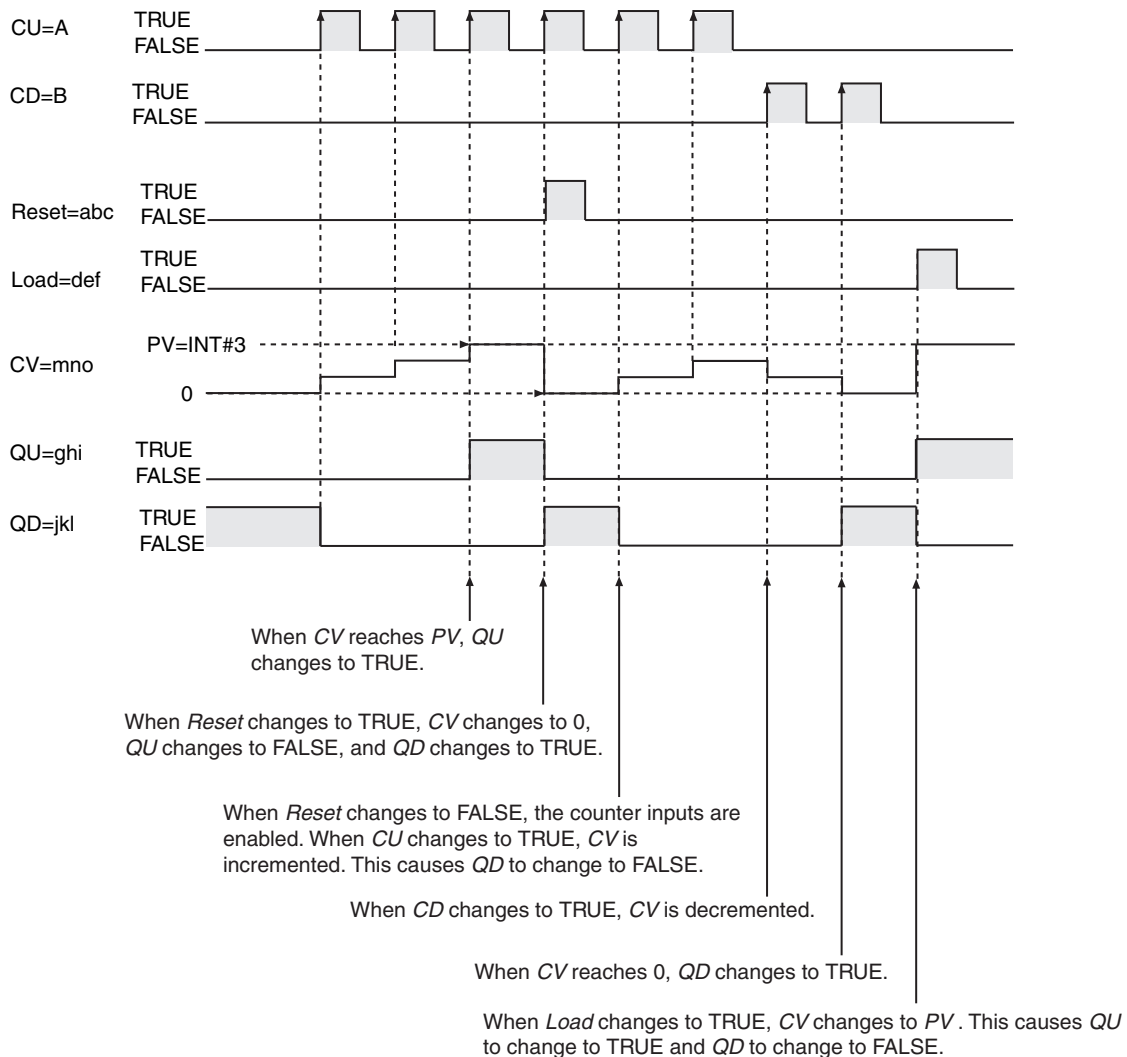

Additional Information

Use the CTD instruction (page 2-146) or CTU instruction (page 2-150) to create a counter that only decrements or only increments.

Precautions for Correct Use

- If you change *Reset* to TRUE to reset the up-counter operation, *QU* will change to FALSE and *QD* will change to TRUE.
- If you change *Load* to TRUE to reset the down-counter operation, *QD* will change to FALSE and *QU* will change to TRUE.
- Even when *PV* is set to a negative value, *CV* is set to the value of *PV* when the value of *Load* changes to TRUE. The value of *CV* will be 0 or less, so the value of *QD* changes to TRUE immediately. After that, the value of *CV* is not decremented even if the value of *CD* changes. When the value of *Reset* changes to TRUE, the value of *CV* changes to 0. The value of *CV* will be the value of *PV* or higher, so the value of *QU* changes to TRUE immediately. After that, the value of *CV* is not incremented even if the value of *CU* changes.
- You can change the value of *PV* during execution of the instruction. If the new value of *PV* is less than the current value of *CV*, the value of *QU* changes to TRUE immediately.
- If the value of *CU* or *CD* is FALSE and the power supply is interrupted or the operating mode is changed to PROGRAM mode, the value of *CV* is incremented or decremented once if the value of *CU* or *CD* is TRUE when instruction execution is restarted.

CTUD_**

The CTUD_** instruction creates an up-down counter that operates according to an up-counter input and a down-counter input. The preset value and counter value must be one of the following data types: DINT, LINT, UDINT, or ULINT.

Instruction	Name	FB/FUN	Graphic expression	ST expression
CTUD_**	Up-down Counter Group	FB		CTUD_**_instance (CU, CD, Reset, Load, PV, QU, QD, CV); "***" must be DINT, LINT, UDINT, or ULINT.

Variables

Name	Meaning	I/O	Description	Valid range	Unit	Default
CU	Up-counter input	Input	Up counter input	Depends on data type.	---	FALSE
CD	Down-counter input		Down counter input			
Reset*1	Reset signal		TRUE: Reset CV to 0.			
Load*1	Load signal		TRUE: CV set to PV.			
PV	Preset value		The final counter value when operating as an up counter The initial counter value when operating as a down counter			
QU	Up-counter output	Output	TRUE: up-counter output ON FALSE: up-counter output OFF	Depends on data type.	---	---
QD	Down-counter output		TRUE: down-counter output ON FALSE: down-counter output OFF			
CV	Counter value		Counter present value			

*1 On Sysmac Studio version 1.03, you can use "R" instead of "Reset" and "LD" instead of "Load" to more clearly show the correspondence between the variables and the parameter names in ST expressions. For example, you can use the following notation: *CTUD_LINT_instance(CU:=A, CD:=B, R:=abc, LD:=def, PV:=LINT#3, QU=>ghi, QD=>jkl, CV=>mno)*;

*2 Negative numbers are excluded.

	Boolean	Bit string					Integers							Real numbers		Times, durations, dates, and text strings				
	BOOL	BYTE	WORD	DWORD	LWORD	USINT	UINT	UDINT	ULINT	SINT	INT	DINT	LINT	REAL	LREAL	TIME	DATE	TOD	DT	STRING
CU	OK																			
CD	OK																			
Reset	OK																			
Load	OK																			
PV								OK	OK			OK	OK							
QU	OK																			
QD	OK																			
CV	Must be the same data type as <i>PV</i>																			

Function

A CTUD_** instruction creates an up-down counter that operates according to an up-counter input signal and a down-counter input signal. The counter has the functions of both an up counter and a down counter. The preset value and counter value must be one of the following data types: DINT, LINT, UDINT, or ULINT. The name of the instruction is determined by the data type of *PV* and *CV*. For example, if they are the LINT data type, the instruction is CTUD_LINT.

Operation as an Up Counter

When reset signal *Reset* changes to TRUE, counter value *CV* changes to 0 and up-counter output *QU* changes to FALSE. When up-counter input signal *CU* changes to TRUE, *CV* is incremented. When the value of *CV* reaches the value of *PV* or higher, the value of *QU* changes to TRUE. After the value of *CV* reaches the value of *PV* or higher, the value of *CV* does not change even if the value of *CU* changes to TRUE.

Operation as a Down Counter

When load signal *Load* changes to TRUE, counter value *CV* changes to the value of preset value *PV* and down-counter output *QD* changes to FALSE. When down-counter input signal *CD* changes to TRUE, *CV* is decremented. When the value of *CV* reaches 0 or less, the value of *QD* changes to TRUE. After the value of *CV* reaches 0 or less, *CV* does not change even if *CD* changes to TRUE.

Common Operation for Up and Down Counters

CU and *CD* are ignored while *Load* or *Reset* is TRUE. *CV* is not incremented or decremented. If both *CU* and *CD* change to TRUE at the same time, *CV* will not change. If *Reset* and *Load* are both TRUE, *Reset* has priority and the value of *CV* changes to 0. If *Reset* changes to TRUE, *CV* changes to 0, and so *QD* changes to TRUE. If *Load* changes to TRUE, the value of *CV* changes to *PV*, and so *QU* changes to TRUE.

The following table shows the relationship between *Reset*, *Load*, *CV*, *QU*, and *QD*. This assumes that the value of *PV* is larger than 0.

Reset	Load	CV	QU	QD	Operation
FALSE	FALSE	0 or lower	FALSE	TRUE	Only up counter operation is performed. • <i>CV</i> is incremented when <i>CU</i> changes to TRUE. It is not decremented when <i>CD</i> changes to TRUE.
		Between 0 and <i>PV</i>	FALSE	FALSE	Both up and down counter operation is performed. • <i>CV</i> is incremented when <i>CU</i> changes to TRUE and decremented when <i>CD</i> changes to TRUE.
		<i>PV</i> or higher	TRUE	FALSE	Only down counter operation is performed. • <i>CV</i> is decremented when <i>CD</i> changes to TRUE. It is not incremented when <i>CU</i> changes to TRUE.
TRUE	FALSE	0	FALSE	TRUE	The up counter is reset. • The value of <i>CV</i> is set to 0.
FALSE	TRUE	<i>PV</i>	TRUE	FALSE	The down counter is reset. • The value of <i>CV</i> is set to <i>PV</i> .
TRUE	TRUE	0	FALSE	TRUE	The up counter is reset. <i>Reset</i> take priority over <i>Load</i> . • The value of <i>CV</i> is set to 0.

The following figure shows a CTUD_LINT programming example and timing chart for a *PV* of LINT#3.

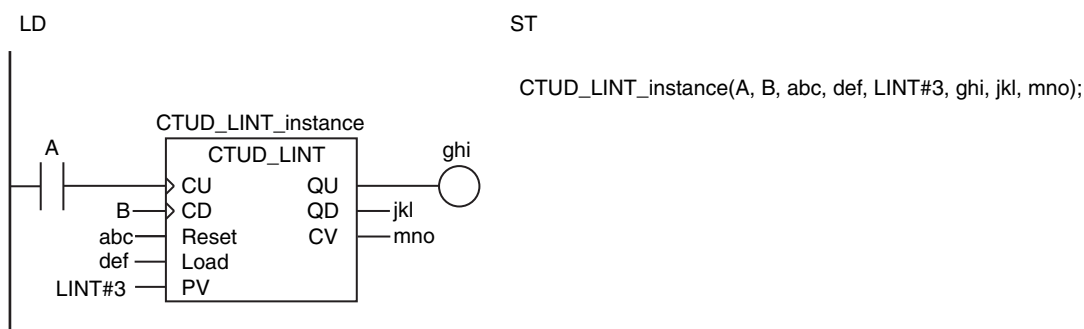

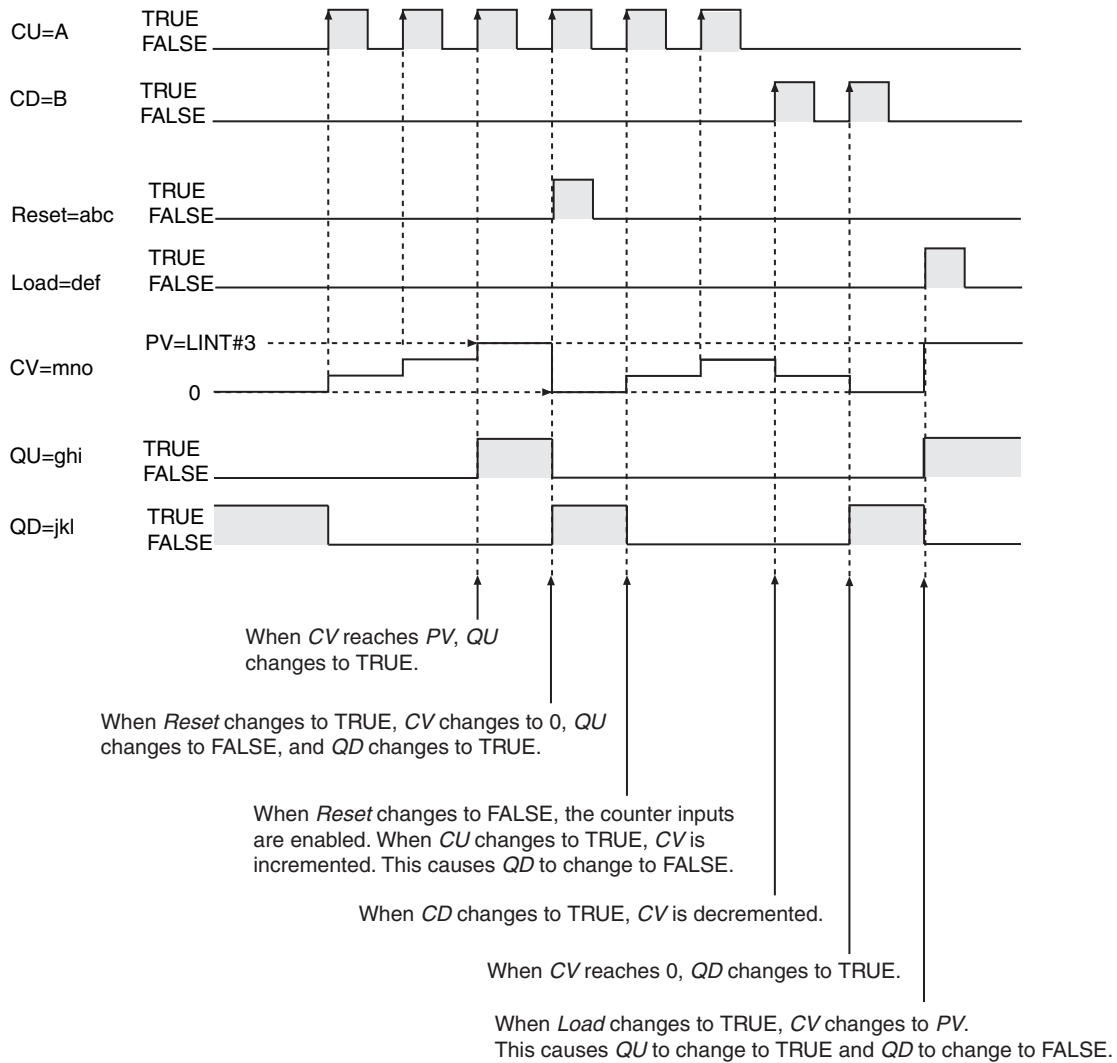

Additional Information

Use the CTD instruction (page 2-146) or CTU instruction (page 2-150) to create a counter that only decrements or only increments.

Precautions for Correct Use

- If you change *Reset* to TRUE to reset the up-counter operation, *QU* will change to FALSE and *QD* will change to TRUE.
- If you change *Load* to TRUE to reset the down-counter operation, *QD* will change to FALSE and *QU* will change to TRUE.
- Even when *PV* is set to a negative value, *CV* is set to the value of *PV* when the value of *Load* changes to TRUE. The value of *CV* will be 0 or less, so the value of *QD* changes to TRUE immediately. After that, the value of *CV* is not decremented even if the value of *CD* changes. When the value of *Reset* changes to TRUE, the value of *CV* changes to 0. The value of *CV* will be the value of *PV* or higher, so the value of *QU* changes to TRUE immediately. After that, the value of *CV* is not incremented even if the value of *CU* changes.
- You can change the value of *PV* during execution of the instruction. If the new value of *PV* is less than the current value of *CV*, the value of *QU* changes to TRUE immediately.
- Use the same data type for *PV* and *CV*.

- If the value of *CU* or *CD* is *FALSE* and the power supply is interrupted or the operating mode is changed to *PROGRAM* mode, the value of *CV* is incremented or decremented once if the value of *CU* or *CD* is *TRUE* when instruction execution is restarted.

Math Instructions

Instruction	Name	Page	Instruction	Name	Page
ADD (+)	Addition	2-166	EXP	Natural Exponential Operation	2-209
AddOU (+OU)	Addition with Overflow Check	2-170	EXPT (**)	Exponentiation	2-211
SUB (-)	Subtraction	2-174	Inc and Dec	Increment/Decrement	2-217
SubOU (-OU)	Subtraction with Overflow Check	2-177	Rand	Random Number	2-219
MUL (*)	Multiplication	2-181	AryAdd	Array Addition	2-221
MulOU (*OU)	Multiplication with Overflow Check	2-185	AryAddV	Array Value Addition	2-223
DIV (/)	Division	2-189	ArySub	Array Subtraction	2-225
MOD	Modulo-division	2-192	ArySubV	Array Value Subtraction	2-227
ABS	Absolute Value	2-194	AryMean	Array Mean	2-229
RadToDeg and DegToRad	Radians to Degrees/ Degrees to Radians	2-196	ArySD	Array Element Standard Deviation	2-231
SIN, COS, and TAN	Sine in Radians/ Cosine in Radians/ Tangent in Radians	2-198	ModReal	Real Number Modulo-division	2-233
ASIN, ACOS, and ATAN	Principal Arc Sine/ Principal Arc Cosine/ Principal Arc Tangent	2-201	Fraction	Real Number Fraction	2-235
SQRT	Square Root	2-204	CheckReal	Real Number Check	2-237
LN and LOG	Natural Logarithm/ Logarithm Base 10	2-206			

ADD (+)

The ADD (+) instruction adds integers or real numbers. It also joins text strings.

Instruction	Name	FB/FUN	Graphic expression	ST expression
ADD (+)	Addition	FUN		Out:=In1 + In2;

Variables

Name	Meaning	I/O	Description	Valid range	Unit	Default
In1 to InN	Add values	Input	Numbers to add Ladder diagram: N = 2 to 5 ST: N = 2*1	Depends on data type.	---	0*2
Out	Output value	Output	Output value	Depends on data type.	---	---

*1 However, you can use more instructions if you use them as operators in an expression, such as *result:= val1 + val2 + val3*. You can use up to 64 instructions in one expression.

*2 If you omit the input parameter that connects to *InN*, the default value is not applied, and a building error will occur. For example, if N is 3 and the input parameters that connect to *In1* and *In2* are omitted, the default values are applied, but if the input parameter that connects to *In3* is omitted, a building error will occur.

	Boolean	Bit strings					Integers							Real numbers	Times, durations, dates, and text strings					
	BOOL	BYTE	WORD	DWORD	LWORD	USINT	UINT	UDINT	ULINT	SINT	INT	DINT	LINT	REAL	LREAL	TIME	DATE	TOD	DT	STRING
In1 to InN						OK	OK	OK	OK	OK	OK	OK	OK	OK						OK
Out						OK	OK	OK	OK	OK	OK	OK	OK	OK						OK

Function

In a ladder diagram, the Add (+) instruction adds between two and five integers or real numbers and outputs the result to output value *Out*. In ST, the Add instruction adds two integers or real numbers and outputs the result to output value *Out*.

Add values *In1* to *InN* can have different data types. However, use the combination that data types to include are existed. If they are different, calculations are performed with the data type that includes the range of all of the data types. For example, if *In1* is INT data and *In2* is DINT data, calculations are performed with DINT data. Here, the addition result is DINT data.

Refer to *Data Type Ranking Table* and *Casting Rules* in the *NJ/NX-series CPU Unit Software User's Manual* (Cat. No. W501) or *NY-series Industrial Panel PC / Industrial Box PC Software User's Manual* (Cat. No. W558) for the including relationship on data types.

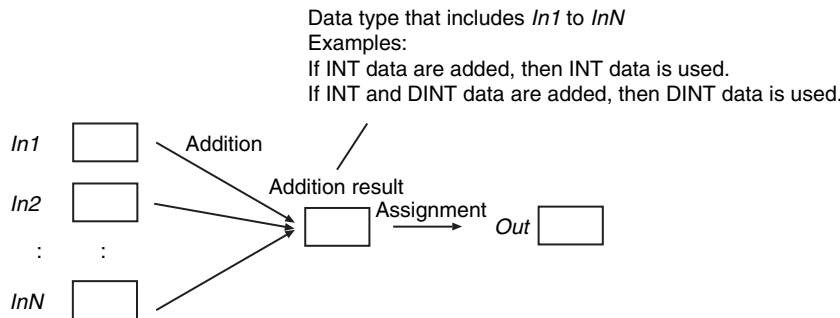

Processing for Overflows

An overflow occurs if the sum of *In1* to *InN* exceeds the valid range of the data type of the addition result. If an overflow occurs, the data types of *In1* to *InN*, the data type of the addition result, and the value of the addition result will be as shown in the following table.

Data types of <i>In1</i> to <i>InN</i>	Data type of addition result	Value of addition result
All integer data	Integer data	Of the sum of <i>In1</i> to <i>InN</i> , the addition result will be the value that can be expressed by the number of bits in the data type of the addition result.*1
At least one real number	Real number data	$\pm\infty$ *2

*1 For example, if the value of *In1* is INT#32767 and the value of *In2* is INT#3, the addition result will be INT data. The value of the addition result will be the lower 16 bits of the sum (32,770), i.e., INT#-32766.

*2 If the sum of *In1* to *InN* is positive, the addition result will be positive infinity. If the sum is negative, the addition result will be negative infinity.

Notation Examples

The following example is for when *In1* is INT#10, *In2* is INT#20 and *In3* is INT#30. The value of INT variable *abc* will be INT#60.

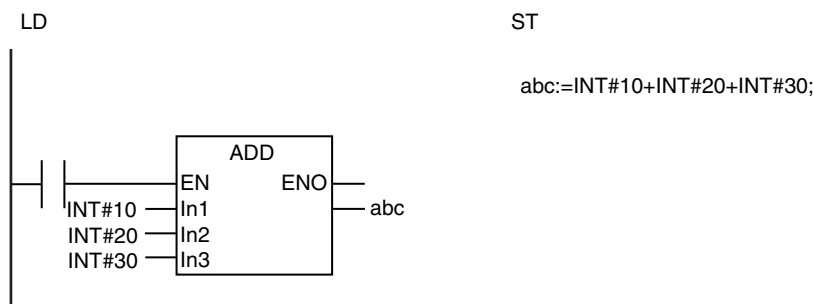

The ADD instruction adds *In1* through *InN*.
 The calculation is 10 + 20 + 30 = 60, so the value of *abc* will be INT#60.

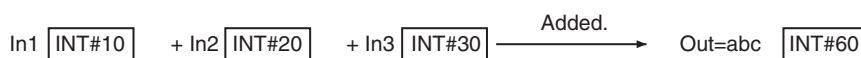

Joining Text Strings

If *In1* to *InN* are STRING data, the text strings are joined. However, if *In1* to *InN* are STRING data, you must use the instruction in a ladder diagram.

The following example is for when *In1* is UV, *In2* is WX and *In3* is YZ. The value of STRING variable *abc* will be 'UVWXYZ'.

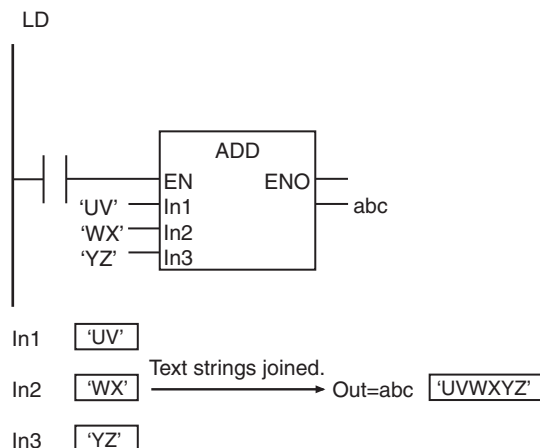

Differences in Specifications between Ladder Diagrams and ST

Specifications of this instruction depend on whether it is used in a ladder diagram or ST. The following table gives the differences in specifications. In ladder diagrams, the specifications of the ADD instruction and the + instruction are exactly the same.

Item	Ladder diagram	ST
Maximum number of values to add	5	2 ^{*1}
Omitting input parameters for values to add	You can omit everything except for the input parameters connected to <i>InN</i> .	You cannot omit any input parameters.
Existence of <i>EN</i> and <i>ENO</i> variables	Present	None
Number of data processing bits if the values to add are all integer data	8, 16, 32, or 64 ^{*2}	32 or 64 ^{*3}
Joining of text strings	Possible.	Not possible.
Errors	An error occurs if the size that results from joining text strings exceeds 1,986 bytes.	None

*1 However, you can use more instructions if you use them as operators in an expression, such as *result := val1 + val2 + val3*;. You can use up to 64 instructions in one expression.

*2 The number of processing bits is aligned with the largest data type of all the values to add. For example, if you add SINT, INT, and DINT data, the data processing bits will be aligned to the size of DINT data, i.e., 32-bit processing is performed.

*3 If there is no LINT or ULINT data in the values to add, 32-bit processing is used. For example, if two SINT values are added, 32-bit processing is used. If there is LINT or ULINT data in the values to add, 64-bit processing is used.

Additional Information

- When you calculate real numbers, use the CheckReal instruction (page 2-237) to see if *Out* is positive infinity, negative infinity, or nonnumeric data.
- Use the CONCAT instruction (page 2-548) to join text strings in structured text.

Precautions for Correct Use

- *Out* can have a different data type than the addition result. However, the data type of *Out* must include the valid range of the data type of the addition result. Otherwise, a building error will occur. Refer to *Data Type Ranking Table* and *Casting Rules* in the *NJ/NX-series CPU Unit Software User's Manual* (Cat. No. W501) or *NY-series Industrial Panel PC / Industrial Box PC Software User's Manual* (Cat. No. W558) for the including relationship on data types.
- When you join text strings, use STRING data for *In1* to *InN* and *Out*.
- An error will not occur even if an underflow or overflow occurs in the addition.
- If an underflow or overflow occurs in addition, the calculation result may not be as expected. Allow sufficient leeway in the sizes of the data types for input and output parameters so that overflows and underflows do not occur.
- Addition results of positive or negative infinity are handled as follows for real number values.

Addition	Addition result
$+\infty$ plus number	$+\infty$
$-\infty$ plus number	$-\infty$
$+\infty$ plus $+\infty$	$+\infty$
$-\infty$ plus $-\infty$	$-\infty$
$+\infty$ plus $-\infty$	Nonnumeric data

- If any of the values of *In1* to *InN* is nonnumeric data, the value of the addition result is nonnumeric data.
- An error will occur in the following cases. *ENO* will be FALSE, and *Out* will not change.
 - The size of the joined text string exceeds 1,986 bytes when joining strings.

AddOU (+OU)

The AddOU (+OU) instruction adds integers and real numbers. It also performs an overflow check for integer addition result.

Instruction	Name	FB/FUN	Graphic expression	ST expression
AddOU (+OU)	Addition with Overflow Check	FUN		Out:=AddOU(In1, ..., InN);

Variables

Name	Meaning	I/O	Description	Valid range	Unit	Default
In1 to InN	Add values	Input	Numbers to add, N = 2 to 5	Depends on data type.	---	0*
Out	Output value	Output	Output value	Depends on data type.	---	---

* If you omit the input parameter that connects to *InN*, the default value is not applied, and a building error will occur. For example, if N is 3 and the input parameters that connect to *In1* and *In2* are omitted, the default values are applied, but if the input parameter that connects to *In3* is omitted, a building error will occur.

	Boolean	Bit strings					Integers							Real numbers	Times, durations, dates, and text strings					
	BOOL	BYTE	WORD	DWORD	LWORD	USINT	UINT	UDINT	ULINT	SINT	INT	DINT	LINT	REAL	LREAL	TIME	DATE	TOD	DT	STRING
In1 to InN						OK	OK	OK	OK	OK	OK	OK	OK	OK *	OK *					
Out						OK	OK	OK	OK	OK	OK	OK	OK	OK	OK					

* If any of *In1* to *InN* is REAL data, an overflow check is not performed.

Function

The AddOU (+OU) instruction adds between two and five integers or real numbers and outputs the result to output value *Out*.

Add values *In1* to *InN* can have different data types. However, use the combination that data types to include are existed. If they are different, calculations are performed with the data type that includes the range of all of the data types. For example, if *In1* is INT data and *In2* is DINT data, calculations are performed with DINT data. Here, the addition result is DINT data.

Refer to *Data Type Ranking Table* and *Casting Rules* in the *NJ/NX-series CPU Unit Software User's Manual* (Cat. No. W501) or *NY-series Industrial Panel PC / Industrial Box PC Software User's Manual* (Cat. No. W558) for the including relationship on data types.

Processing for Overflows

An overflow occurs if the sum of $In1$ to InN exceeds the valid range of the data type of the addition result. If all of $In1$ to InN are integer data and an overflow occurs, the value of the P_CY system-defined variable (Carry Flag) changes to TRUE.

If any of $In1$ to InN is REAL data, an overflow check is not performed. Therefore the value of P_CY will not change.

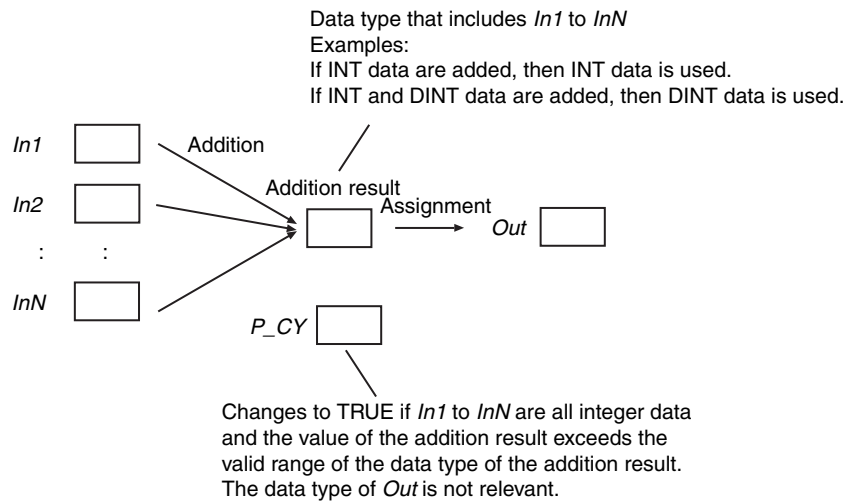

If an overflow occurs, the data types of $In1$ to InN , the data type of the addition result, the value of the addition result, and the value of P_CY will be as shown in the following table.

Data types of $In1$ to InN	Data type of addition result	Value of addition result	Value of P_CY
All integer data	Integer data	Of the sum of $In1$ to InN , the addition result will be the value that can be expressed by the number of bits in the data type of the addition result.*1	TRUE
At least one real number	Real number data	$\pm\infty$ *2	Does not change.

*1 For example, if the value of $In1$ is INT#32767 and the value of $In2$ is INT#3, the addition result will be INT data. The value of the addition result will be the lower 16 bits of the sum (32,770), i.e., INT#-32766.

*2 If the sum of $In1$ to InN is positive, the addition result will be positive infinity. If the sum is negative, the addition result will be negative infinity.

Notation Examples

The following example is for when *In1* is INT#32767, *In2* is INT#1 and variable *abc* has an INT data type. *In1* to *InN* are all INT data, so the addition result is INT data. The sum of the two numbers (32,768) exceeds the valid range of INT data, so the value of *P_CY* changes to TRUE. The value of INT variable *abc* will be INT#-32768 (the lower 16 bits of 32,768).

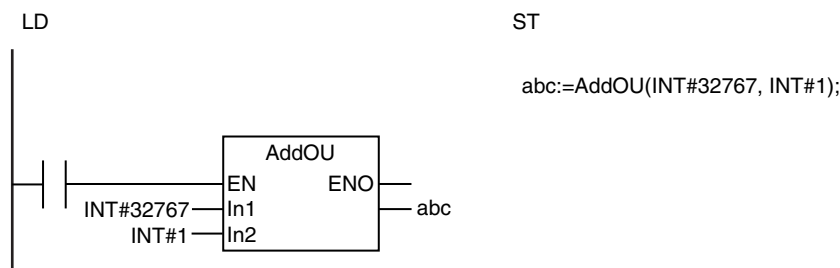

The AddOU instruction adds *In1* to *InN*.
The sum of the two numbers (32,768) exceeds the valid range of INT data, so the value of *P_CY* changes to TRUE.

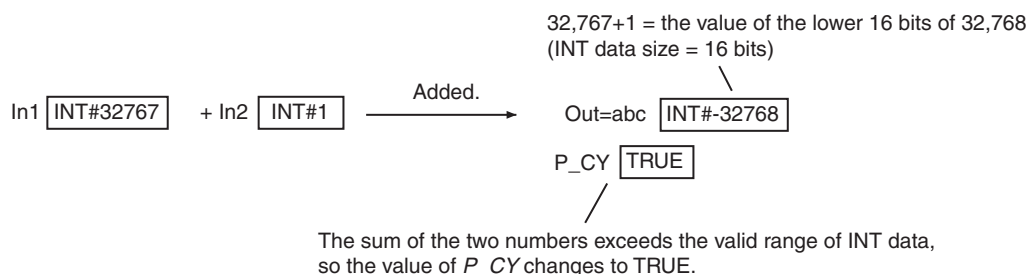

Differences in Specifications between Ladder Diagrams and ST

There are no differences in the specifications of this instruction regardless of whether it is used in a ladder diagram or ST. In ladder diagrams, there are no differences in the specifications of the AddOU instruction and the +OU instruction.

Related System-defined Variables

Name	Meaning	Data type	Description
P_CY	Carry (CY) Flag	BOOL	TRUE: Overflow occurred for integer calculations. FALSE: Overflow did not occur for integer calculations.

Additional Information

- If *Out* is REAL data, use the CheckReal instruction (page 2-237) to see if *Out* is positive infinity, negative infinity, or nonnumeric data.
- Use the ADD (+) instruction (page 2-166) if there is no need for an overflow check. It will reduce processing time.

Precautions for Correct Use

- *Out* can have a different data type than the addition result. However, the data type of *Out* must include the valid range of the data type of the addition result. Otherwise, a building error will occur. Refer to *Data Type Ranking Table* and *Casting Rules* in the *NJ/NX-series CPU Unit Software User's Manual* (Cat. No. W501) or *NY-series Industrial Panel PC / Industrial Box PC Software User's Manual* (Cat. No. W558) for the including relationship on data types.
- If an underflow or overflow occurs in addition, the calculation result may not be as expected. Allow sufficient leeway in the sizes of the data types for input and output parameters so that overflows and underflows do not occur.
- Addition results of positive or negative infinity are handled as follows for real number values.

Addition	Addition result
$+\infty$ plus number	$+\infty$
$-\infty$ plus number	$-\infty$
$+\infty$ plus $+\infty$	$+\infty$
$-\infty$ plus $-\infty$	$-\infty$
$+\infty$ plus $-\infty$	Nonnumeric data

- If any of the values of *In1* to *InN* is nonnumeric data, the value of the addition result is nonnumeric data.

SUB (-)

The SUB (-) instruction subtracts integers and real numbers.

Instruction	Name	FB/FUN	Graphic expression	ST expression
SUB (-)	Subtraction	FUN		Out:=In1 - In2;

Variables

Name	Meaning	I/O	Description	Valid range	Unit	Default
In1	Minuend	Input	Minuend	Depends on data type.	---	0*
In2	Subtrahend		Subtrahend			
Out	Output value	Output	Output value	Depends on data type.	---	---

* If you omit an input parameter, the default value is not applied. A building error will occur.

	Boolean	Bit string					Integers							Real numbers	Times, durations, dates, and text strings					
	BOOL	BYTE	WORD	DWORD	LWORD	USINT	UINT	UDINT	ULINT	SINT	INT	DINT	LINT	REAL	LREAL	TIME	DATE	TOD	DT	STRING
In1						OK	OK	OK	OK	OK	OK	OK	OK	OK	OK					
In2						OK	OK	OK	OK	OK	OK	OK	OK	OK	OK					
Out						OK	OK	OK	OK	OK	OK	OK	OK	OK	OK					

Function

The SUB (-) instruction subtracts subtrahend *In2* from minuend *In1* and outputs the result to output value *Out*.

In1 and *In2* can have different data types. However, use the combination that data types to include are existed. If they are different, calculations are performed with the data type that includes the range of all of the data types. For example, if *In1* is INT data and *In2* is DINT data, calculations are performed with DINT data. Here, the subtraction result is DINT data.

Data type that includes *In1* and *In2*

Examples:

If subtraction is performed for INT data, then INT data is used.

If subtraction is performed for INT and DINT data, then DINT data is used.

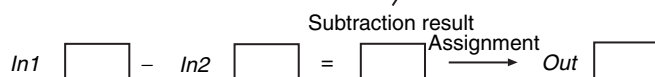

Refer to *Data Type Ranking Table* and *Casting Rules* in the *NJ/NX-series CPU Unit Software User's Manual* (Cat. No. W501) or *NY-series Industrial Panel PC / Industrial Box PC Software User's Manual* (Cat. No. W558) for the including relationship on data types.

Processing for Overflows

An overflow occurs if the difference between *In1* and *In2* exceeds the valid range of the data type of the subtraction result. If an overflow occurs, the data types of *In1* and *In2*, the data type of the subtraction result, and the value of the subtraction result will be as shown in the following table.

Data types of <i>In1</i> and <i>In2</i>	Data type of subtraction result	Value of subtraction result
All integer data	Integer data	Of the difference between <i>In1</i> to <i>InN</i> , the subtraction result will be the value that can be expressed by the number of bits in the data type of the subtraction result.*1
At least one real number	Real number data	$\pm\infty$ *2

*1 For example, if the value of *In1* is INT#32767 and the value of *In2* is INT#3, the subtraction result will be INT data. The value of the subtraction result will be the lower 16 bits of the difference (32,770), i.e., INT#-32766.

*2 If the difference between *In1* and *InN* is positive, the subtraction result will be positive infinity. If the difference is negative, the subtraction result will be negative infinity.

Notation Examples

The following example is for when *In1* is INT#50 and *In2* is INT#10. The value of INT variable *abc* will be INT#40.

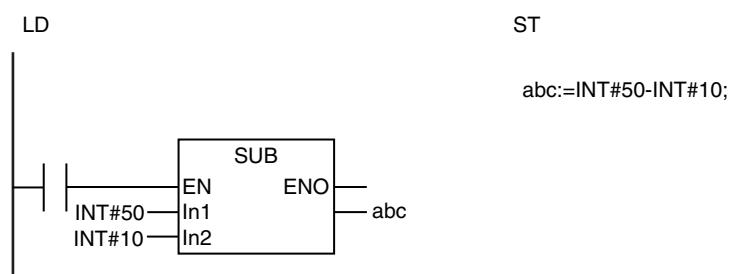

The SUB instruction subtracts *In2* from *In1*.
The calculation is $50 - 10 = 40$, so the value of *abc* will be INT#40.

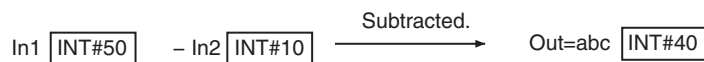

Differences in Specifications between Ladder Diagrams and ST

Specifications of this instruction depend on whether it is used in a ladder diagram or ST. The following table gives the differences in specifications. In ladder diagrams, the specifications of the SUB instruction and the - instruction are exactly the same.

Item	Ladder diagram	ST
Existence of <i>EN</i> and <i>ENO</i> variables	Present	None
Number of data processing bits if the minuend and subtrahend are integer data	8, 16, 32, or 64*1	32 or 64*2

*1 The number of processing bits is aligned with the larger data type of the minuend and subtrahend. For example, if you perform subtraction for SINT and DINT data, the data processing bits will be aligned to the size of DINT data, i.e., 32-bit processing is performed.

*2 If there is no LINT or ULINT data in the minuend and subtrahend, 32-bit processing is used. For example, if you perform subtraction for two SINT values, 32-bit processing is used. If there is LINT or ULINT data in the minuend and subtrahend, 64-bit processing is used.

Additional Information

When you calculate real numbers, use the CheckReal instruction (page 2-237) to see if *Out* is positive infinity, negative infinity, or nonnumeric data.

Precautions for Correct Use

- *Out* can have a different data type than the subtraction result. However, the data type of *Out* must include the valid range of the data type of the subtraction result. Otherwise, a building error will occur. Refer to *Data Type Ranking Table* and *Casting Rules* in the *NJ/NX-series CPU Unit Software User's Manual* (Cat. No. W501) or *NY-series Industrial Panel PC / Industrial Box PC Software User's Manual* (Cat. No. W558) for the including relationship on data types.
- An error will not occur even if an underflow or overflow occurs in the subtraction.
- If an underflow or overflow occurs in subtraction, the calculation result may not be as expected. Allow sufficient leeway in the sizes of the data types for input and output parameters so that overflows and underflows do not occur.
- Subtraction results of positive or negative infinity are handled as follows for real number values.

Subtraction	Subtraction result
$+\infty$ minus number	$+\infty$
Number minus $+\infty$	$-\infty$
$-\infty$ minus number	$-\infty$
Number minus $-\infty$	$+\infty$
$+\infty$ minus $+\infty$	Nonnumeric data
$+\infty$ minus $-\infty$	$+\infty$
$-\infty$ minus $+\infty$	$-\infty$
$-\infty$ minus $-\infty$	Nonnumeric data

- If the value of *In1* or *In2* is nonnumeric data, the value of the subtraction result is nonnumeric data.

SubOU (-OU)

The SubOU (-OU) instruction subtracts integers or real numbers. It also performs an overflow check for integer subtraction result.

Instruction	Name	FB/FUN	Graphic expression	ST expression
SubOU (-OU)	Subtraction with Overflow Check	FUN		Out:=SubOU(In1, In2);

Variables

Name	Meaning	I/O	Description	Valid range	Unit	Default
In1	Minuend	Input	Minuend	Depends on data type.	---	0*
In2	Subtrahend		Subtrahend			
Out	Output value	Output	Output value	Depends on data type.	---	---

* If you omit an input parameter, the default value is not applied. A building error will occur.

	Boolean	Bit strings				Integers							Real numbers		Times, durations, dates, and text strings					
	BOOL	BYTE	WORD	DWORD	LWORD	USINT	UINT	UDINT	ULINT	SINT	INT	DINT	LINT	REAL	LREAL	TIME	DATE	TOD	DT	STRING
In1						OK	OK	OK	OK	OK	OK	OK	OK	OK *	OK *					
In2						OK	OK	OK	OK	OK	OK	OK	OK	OK *	OK *					
Out						OK	OK	OK	OK	OK	OK	OK	OK	OK	OK					

* If *In1* or *In2* is REAL data, an overflow check is not performed.

Function

The SubOU (-OU) instruction subtracts subtrahend *In2* from minuend *In1* and outputs the result to output value *Out*.

In1 and *In2* can have different data types. However, use the combination that data types to include are existed. If they are different, calculations are performed with the data type that includes the range of all of the data types. For example, if *In1* is INT data and *In2* is DINT data, calculations are performed with DINT data. Here, the subtraction result is DINT data.

Refer to *Data Type Ranking Table* and *Casting Rules* in the *NJ/NX-series CPU Unit Software User's Manual* (Cat. No. W501) or *NY-series Industrial Panel PC / Industrial Box PC Software User's Manual* (Cat. No. W558) for the including relationship on data types.

Processing for Overflows

An overflow occurs if the difference between *In1* and *In2* exceeds the valid range of the data type of the subtraction result. If *In1* and *In2* are both integer data and an overflow occurs, the value of the *P_CY* system-defined variable (Carry Flag) changes to TRUE.

If either *In1* or *In2* is REAL data, an overflow check is not performed. Therefore the value of *P_CY* will not change.

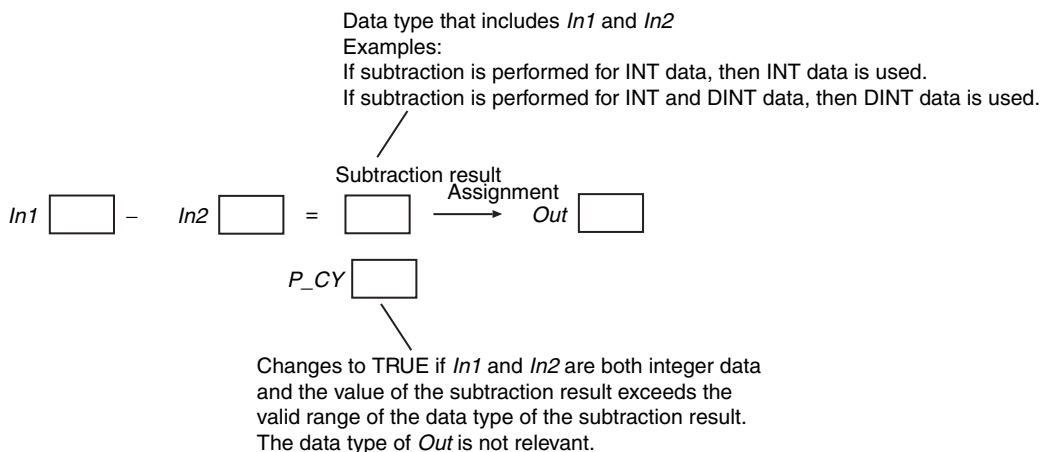

If an overflow occurs, the data types of *In1* and *In2*, the data type of the subtraction result, the value of the subtraction result, and the value of *P_CY* will be as shown in the following table.

Data types of <i>In1</i> and <i>In2</i>	Data type of subtraction result	Value of subtraction result	Value of <i>P_CY</i>
All integer data	Integer data	Of the difference between <i>In1</i> to <i>InN</i> , the subtraction result will be the value that can be expressed by the number of bits in the data type of the subtraction result.*1	TRUE
At least one real number	Real number data	$\pm\infty$ *2	Does not change.

*1 For example, if the value of *In1* is INT#32767 and the value of *In2* is INT#-3, the subtraction result will be INT data. The value of the subtraction result will be the lower 16 bits of the difference (32,770), i.e., INT#-32766.

*2 If the difference between *In1* and *InN* is positive, the subtraction result will be positive infinity. If the difference is negative, the subtraction result will be negative infinity.

Notation Examples

The following example is for when *In1* is SINT#-128, *In2* is SINT#1, and variable *abc* is SINT data. *In1* and *In2* are both SINT data, so the subtraction result is SINT data. The difference between the two values (-129) exceeds the valid range of SINT data, so the value of *P_CY* changes to TRUE. The value of SINT variable *abc* will be SINT#127 (the value of the lower eight bits of -129).

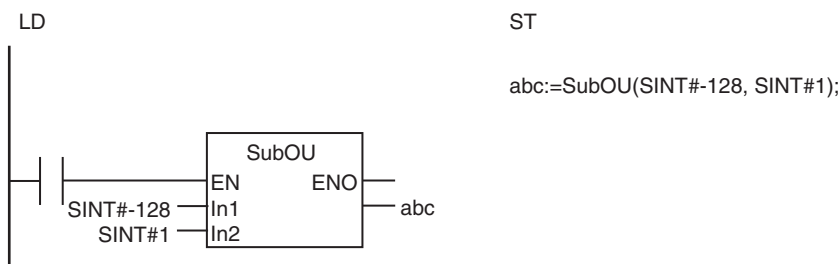

The SubOU instruction subtracts *In2* from *In1*.

The difference between the two values (-129) exceeds the valid range of SINT data, so the value of *P_CY* changes to TRUE.

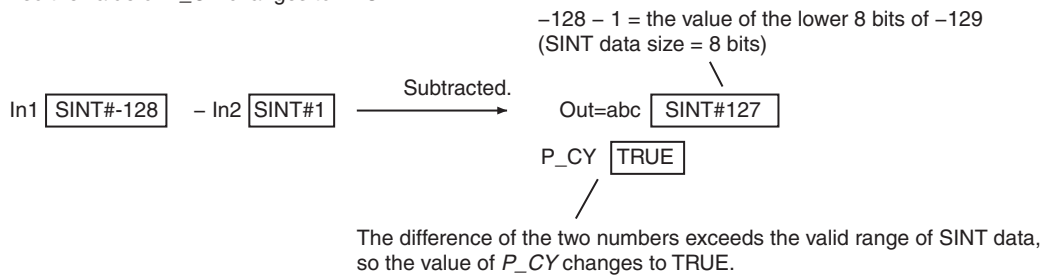

Differences in Specifications between Ladder Diagrams and ST

There are no differences in the specifications of this instruction regardless of whether it is used in a ladder diagram or ST. In ladder diagrams, there are no differences in the specifications of the SubOU instruction and the - OU instruction.

Related System-defined Variables

Name	Meaning	Data type	Description
P_CY	Carry (CY) Flag	BOOL	TRUE: Overflow occurred for integer calculations. FALSE: Overflow did not occur for integer calculations.

Additional Information

- When you calculate real numbers, use the CheckReal instruction (page 2-237) to see if *Out* is positive infinity, negative infinity, or nonnumeric data.
- Use the SUB (-) instruction (page 2-174) if there is no need for an overflow check. It will reduce processing time.

Precautions for Correct Use

- *Out* can have a different data type than the subtraction result. However, the data type of *Out* must include the valid range of the data type of the subtraction result. Otherwise, a building error will occur. Refer to *Data Type Ranking Table* and *Casting Rules* in the *NJ/NX-series CPU Unit Software User's Manual* (Cat. No. W501) or *NY-series Industrial Panel PC / Industrial Box PC Software User's Manual* (Cat. No. W558) for the including relationship on data types.
- If an underflow or overflow occurs in subtraction, the calculation result may not be as expected. Allow sufficient leeway in the sizes of the data types for input and output parameters so that overflows and underflows do not occur.
- Subtraction results of positive or negative infinity are handled as follows for real number values.

Subtraction	Subtraction result
$+\infty$ minus number	$+\infty$
Number minus $+\infty$	$-\infty$
$-\infty$ minus number	$-\infty$
Number minus $-\infty$	$+\infty$
$+\infty$ minus $+\infty$	Nonnumeric data
$+\infty$ minus $-\infty$	$+\infty$
$-\infty$ minus $+\infty$	$-\infty$
$-\infty$ minus $-\infty$	Nonnumeric data

- If the value of *In1* or *In2* is nonnumeric data, the value of the subtraction result is nonnumeric data.

MUL (*)

The MUL (*) instruction multiplies integers and real numbers.

Instruction	Name	FB/FUN	Graphic expression	ST expression
MUL (*)	Multiplication	FUN		Out:=In1 * In2;

Variables

Name	Meaning	I/O	Description	Valid range	Unit	Default
In1 to InN	Values to multiply	Input	Numbers to multiply Ladder diagram: N = 2 to 5 ST: N = 2*1	Depends on data type.	---	1*2
Out	Output value	Output	Output value	Depends on data type.	---	---

*1 However, you can use more instructions if you use them as operators in an expression, such as *result:= val1 * val2 * val3*;. You can use up to 64 instructions in one expression.

*2 If you omit the input parameter that connects to *InN*, the default value is not applied, and a building error will occur. For example, if N is 3 and the input parameters that connect to *In1* and *In2* are omitted, the default values are applied, but if the input parameter that connects to *In3* is omitted, a building error will occur.

	Boolean	Bit string				Integers							Real numbers		Times, durations, dates, and text strings					
	BOOL	BYTE	WORD	DWORD	LWORD	USINT	UINT	UDINT	ULINT	SINT	INT	DINT	LINT	REAL	LREAL	TIME	DATE	TOD	DT	STRING
In1 to InN						OK	OK	OK	OK	OK	OK	OK	OK	OK	OK					
Out						OK	OK	OK	OK	OK	OK	OK	OK	OK	OK					

Function

In a ladder diagram, the MUL (*) instruction multiplies between two and five integers or real numbers and outputs the result to output value *Out*. In ST, the MUL instruction multiplies two integers or real numbers and outputs the result to output value *Out*.

Values to multiply *In1* to *InN* can have different data types. However, use the combination that data types to include are existed. If they are different, calculations are performed with the data type that includes the range of all of the data types. For example, if *In1* is INT data and *In2* is DINT data, calculations are performed with DINT data. Here, the multiplication result is DINT data.

Refer to *Data Type Ranking Table* and *Casting Rules* in the *NJ/NX-series CPU Unit Software User's Manual* (Cat. No. W501) or *NY-series Industrial Panel PC / Industrial Box PC Software User's Manual* (Cat. No. W558) for the including relationship on data types.

Data type that includes $In1$ to InN
 Examples:
 If INT data are multiplied, then INT data is used.
 If INT and DINT data are multiplied, then DINT data is used.

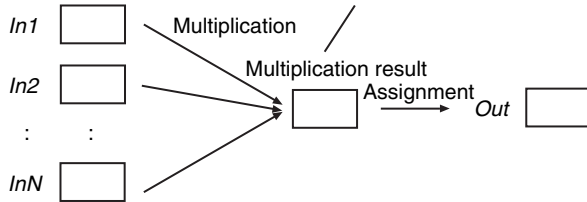

Processing for Overflows

An overflow occurs if the product of $In1$ to InN exceeds the valid range of the data type of the multiplication result. If an overflow occurs, the data types of $In1$ to InN , the data type of the multiplication result, and the value of the multiplication result will be as shown in the following table.

Data types of $In1$ to InN	Data type of multiplication result	Value of multiplication result
All integer data	Integer data	Of the product of $In1$ to InN , the multiplication result will be the value that can be expressed by the number of bits in the data type of the multiplication result.*1
At least one real number	Real number data	$\pm\infty$ *2

*1 For example, if the value of $In1$ is INT#16384 and the value of $In2$ is INT#2, the multiplication result will be INT data. The value of the multiplication result will be the lower 16 bits of the product (32,768), i.e., INT#-32768.

*2 If the product of $In1$ to InN is positive, the multiplication result will be positive infinity. If the product is negative, the multiplication result will be negative infinity.

Notation Examples

The following example is for when $In1$ is INT#10, $In2$ is INT#20 and $In3$ is INT#30. The value of INT variable abc will be INT#6000.

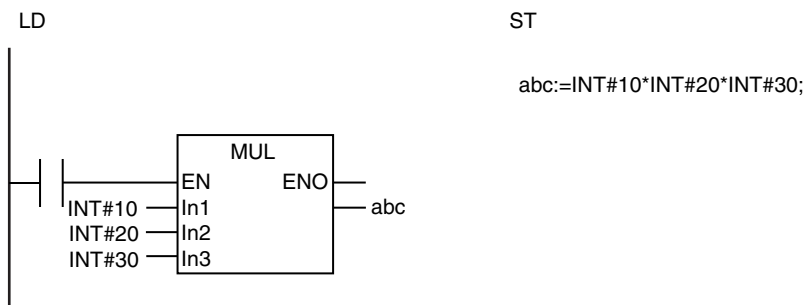

The MUL instruction multiplies $In1$ to InN .
 The calculation is $10 \times 20 \times 30 = 6,000$, so the value of abc will be INT#6000.



Differences in Specifications between Ladder Diagrams and ST

Specifications of this instruction depend on whether it is used in a ladder diagram or ST. The following table gives the differences in specifications. In ladder diagrams, the specifications of the MUL instruction and the * instruction are exactly the same.

Item	Ladder diagram	ST
Maximum number of values to multiply	5	2*1
Omitting input parameters for values to multiply	You can omit everything except for the input parameters connected to <i>InN</i> .	You cannot omit any input parameters.
Existence of <i>EN</i> and <i>ENO</i> variables	Present	None
Number of data processing bits if the values to multiply are all integer data	8, 16, 32, or 64*2	32 or 64*3

*1 However, you can use more instructions if you use them as operators in an expression, such as *result:= val1 * val2 * val3*. You can use up to 64 instructions in one expression.

*2 The number of processing bits is aligned with the largest data type of all the values to multiply. For example, if you multiply SINT, INT, and DINT data, the data processing bits will be aligned to the size of DINT data, i.e., 32-bit processing is performed.

*3 If there is no LINT or ULINT data in the values to multiply, 32-bit processing is used. For example, if two SINT values are multiplied, 32-bit processing is used. If there is LINT or ULINT data in the values to multiply, 64-bit processing is used.

Additional Information

When you calculate real numbers, use the CheckReal instruction (page 2-237) to see if *Out* is positive infinity, negative infinity, or nonnumeric data.

Precautions for Correct Use

- *Out* can have a different data type than the multiplication result. However, the data type of *Out* must include the valid range of the data type of the multiplication result. Otherwise, a building error will occur. Refer to *Data Type Ranking Table* and *Casting Rules* in the *NJ/NX-series CPU Unit Software User's Manual* (Cat. No. W501) or *NY-series Industrial Panel PC / Industrial Box PC Software User's Manual* (Cat. No. W558) for the including relationship on data types.
- An error will not occur even if an underflow or overflow occurs in the multiplication.
- If an underflow or overflow occurs in multiplication, the calculation result may not be as expected. Allow sufficient leeway in the sizes of the data types for input and output parameters so that overflows and underflows do not occur.
- Multiplication results of positive or negative infinity are handled as follows for real number values.

Multiplication	Multiplication result
$+\infty$ times positive number	$+\infty$
$+\infty$ times negative number	$-\infty$
$-\infty$ times positive number	$-\infty$
$-\infty$ times negative number	$+\infty$
$+\infty$ times $+\infty$	$+\infty$
$-\infty$ times $-\infty$	$+\infty$
$+\infty$ times $-\infty$	$-\infty$
$+\infty$ times 0	Nonnumeric data
$-\infty$ times 0	Nonnumeric data

- If any of the values of $In1$ to InN is nonnumeric data, the value of the multiplication result is nonnumeric data.

MulOU (*OU)

The MulOU (*OU) instruction multiplies integers and real numbers and outputs the result. It also performs an overflow check for integer multiplication result.

Instruction	Name	FB/FUN	Graphic expression	ST expression
MulOU (*OU)	Multiplication with Overflow Check	FUN		Out:=MulOU(In1, ..., InN);

Variables

Name	Meaning	I/O	Description	Valid range	Unit	Default
In1 to InN	Values to multiply	Input	Numbers to multiply, N = 2 to 5	Depends on data type.	---	1*
Out	Output value	Output	Output value	Depends on data type.	---	---

* If you omit the input parameter that connects to *InN*, the default value is not applied, and a building error will occur. For example, if N is 3 and the input parameters that connect to *In1* and *In2* are omitted, the default values are applied, but if the input parameter that connects to *In3* is omitted, a building error will occur.

	Boolean	Bit string				Integers							Real numbers		Times, durations, dates, and text strings					
	BOOL	BYTE	WORD	DWORD	LWORD	USINT	UINT	UDINT	ULINT	SINT	INT	DINT	LINT	REAL	LREAL	TIME	DATE	TOD	DT	STRING
In1 to InN						OK	OK	OK	OK	OK	OK	OK	OK	OK *	OK *					
Out						OK	OK	OK	OK	OK	OK	OK	OK	OK	OK					

* If any of *In1* to *InN* is REAL data, an overflow check is not performed.

Function

The MUL (*) instruction multiplies between two and five integers or real numbers and outputs the result to output value *Out*.

Values to multiply *In1* to *InN* can have different data types. However, use the combination that data types to include are existed. If they are different, calculations are performed with the data type that includes the range of all of the data types. For example, if *In1* is INT data and *In2* is DINT data, calculations are performed with DINT data. Here, the multiplication result is DINT data.

Refer to *Data Type Ranking Table* and *Casting Rules* in the *NJ/NX-series CPU Unit Software User's Manual* (Cat. No. W501) or *NY-series Industrial Panel PC / Industrial Box PC Software User's Manual* (Cat. No. W558) for the including relationship on data types.

The MulOU instruction multiplies *In1* to *InN*.

The product of the two values (40,000) exceeds the valid range of INT data, so the value of *P_CY* changes to TRUE.

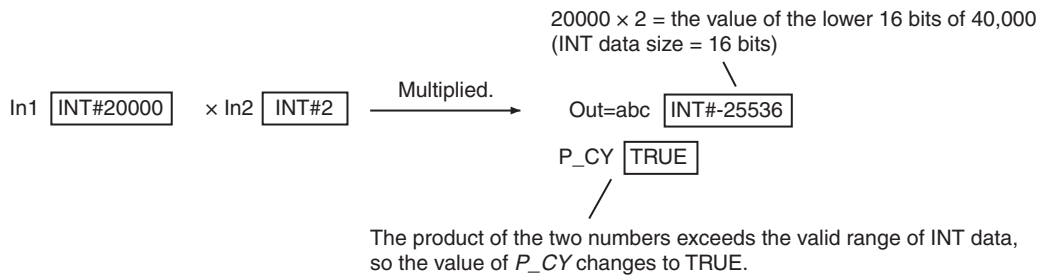

Differences in Specifications between Ladder Diagrams and ST

There are no differences in the specifications of this instruction regardless of whether it is used in a ladder diagram or ST. In ladder diagrams, there are no differences in the specifications of the MulOU instruction and the *OU instruction.

Related System-defined Variables

Name	Meaning	Data type	Description
P_CY	Carry (CY) Flag	BOOL	TRUE: Overflow occurred for integer calculations. FALSE: Overflow did not occur for integer calculations.

Additional Information

- When you calculate real numbers, use the CheckReal instruction (page 2-237) to see if *Out* is positive infinity, negative infinity, or nonnumeric data.
- Use the MUL (*) instruction (page 2-181) if there is no need for an overflow check. It will reduce processing time.

Precautions for Correct Use

- *Out* can have a different data type than the multiplication result. However, the data type of *Out* must include the valid range of the data type of the multiplication result. Otherwise, a building error will occur. Refer to *Data Type Ranking Table* and *Casting Rules* in the *NJ/NX-series CPU Unit Software User's Manual* (Cat. No. W501) or *NY-series Industrial Panel PC / Industrial Box PC Software User's Manual* (Cat. No. W558) for the including relationship on data types.
- If an underflow or overflow occurs in multiplication, the calculation result may not be as expected. Allow sufficient leeway in the sizes of the data types for input and output parameters so that overflows and underflows do not occur.
- Multiplication results of positive or negative infinity are handled as follows for real number values.

Multiplication	Multiplication result
$+\infty$ times positive number	$+\infty$
$+\infty$ times negative number	$-\infty$
$-\infty$ times positive number	$-\infty$
$-\infty$ times negative number	$+\infty$
$+\infty$ times $+\infty$	$+\infty$
$-\infty$ times $-\infty$	$+\infty$
$+\infty$ times $-\infty$	$-\infty$
$+\infty$ times 0	Nonnumeric data
$-\infty$ times 0	Nonnumeric data

- If any of the values of *In1* to *InN* is nonnumeric data, the value of the multiplication result is nonnumeric data.

DIV (/)

The DIV (/) instruction divides integers or real numbers.

Instruction	Name	FB/FUN	Graphic expression	ST expression
DIV (/)	Division	FUN		Out:=In1/ In2;

Variables

Name	Meaning	I/O	Description	Valid range	Unit	Default
In1	Dividend	Input	Dividend	Depends on data type.	---	*
In2	Divisor		Divisor			
Out	Output value	Output	Output value	Depends on data type.	---	---

* If you omit an input parameter, the default value is not applied. A building error will occur.

	Boolean	Bit string				Integers							Real numbers	Times, durations, dates, and text strings						
	BOOL	BYTE	WORD	DWORD	LWORD	USINT	UINT	UDINT	ULINT	SINT	INT	DINT	LINT	REAL	LREAL	TIME	DATE	TOD	DT	STRING
In1						OK	OK	OK	OK	OK	OK	OK	OK	OK	OK					
In2						OK	OK	OK	OK	OK	OK	OK	OK	OK	OK					
Out						OK	OK	OK	OK	OK	OK	OK	OK	OK	OK					

Function

The DIV (/) instruction divides dividend *In1* by divisor *In2* and outputs the result to output value *Out*.

In1 and *In2* can have different data types. However, use the combination that data types to include are existed. If they are different, calculations are performed with the data type that includes the range of all of the data types. For example, if *In1* is INT data and *In2* is DINT data, calculations are performed with DINT data. Here, the division result is DINT data.

If *In1* and *In2* are integers and there is a remainder, the remainder is truncated.

Refer to *Data Type Ranking Table* and *Casting Rules* in the *NJ/NX-series CPU Unit Software User's Manual* (Cat. No. W501) or *NY-series Industrial Panel PC / Industrial Box PC Software User's Manual* (Cat. No. W558) for the including relationship on data types.

Data type that includes *In1* and *In2*
 Examples:
 If division is performed for INT data, then INT data is used.
 If division is performed for INT and DINT data, then DINT data is used.

 If *In1* and *In2* are integers and there is a remainder, the remainder is truncated.

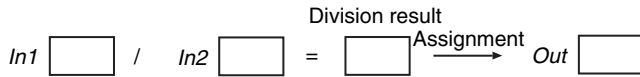

Processing for Overflows

An overflow occurs if the quotient of *In1* and *In2* exceeds the valid range of the data type of the division result. If an overflow occurs, the data types of *In1* and *In2*, the data type of the division result, and the value of the division result will be as shown in the following table.

Data types of <i>In1</i> and <i>In2</i>	Data type of division result	Value of division result
At least one real number	Real number data	$\pm\infty^*$

* If the quotient of *In1* and *In2* is positive, the division result will be positive infinity. If the quotient is negative, the division result will be negative infinity.

Notation Examples

The following example is for when *In1* is INT#100 and *In2* is INT#5. The value of INT variable *abc* will be INT#20.

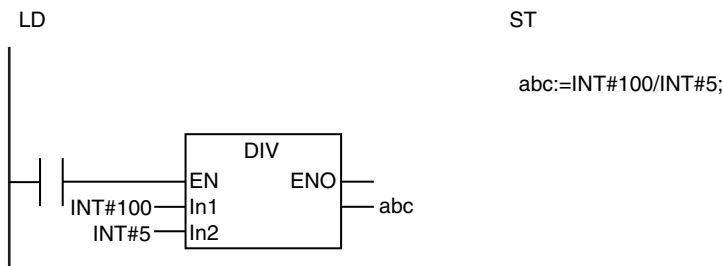

The DIV instruction divides *In1* by *InN*.
 The calculation is $100/5 = 20$, so the value of *abc* will be INT#20.

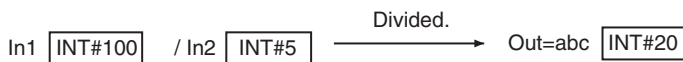

Differences in Specifications between Ladder Diagrams and ST

Specifications of this instruction depend on whether it is used in a ladder diagram or ST. The following table gives the differences in specifications. In ladder diagrams, the specifications of the DIV instruction and the / instruction are exactly the same.

Item	Ladder diagram	ST
Existence of <i>EN</i> and <i>ENO</i> variables	Present	None
Number of data processing bits if the dividend and divisor are integer data	8, 16, 32, or 64*1	32 or 64*2

*1 The number of processing bits is aligned with the larger data type of the dividend and divisor. For example, if you perform division for SINT and DINT data, the data processing bits will be aligned to the size of DINT data, i.e., 32-bit processing is performed.

*2 If there is no LINT or ULINT data in the dividend and divisor, 32-bit processing is used. For example, if you perform division for two SINT values, 32-bit processing is used. If there is LINT or ULINT data in the dividend and divisor, 64-bit processing is used.

Additional Information

When you calculate real numbers, use the CheckReal instruction (page 2-237) to see if *Out* is positive infinity, negative infinity, or nonnumeric data.

Precautions for Correct Use

- *Out* can have a different data type than the division result. However, the data type of *Out* must include the valid range of the data type of the division result. Otherwise, a building error will occur. Refer to *Data Type Ranking Table* and *Casting Rules* in the *NJ/NX-series CPU Unit Software User's Manual* (Cat. No. W501) or *NY-series Industrial Panel PC / Industrial Box PC Software User's Manual* (Cat. No. W558) for the including relationship on data types.
- An error will not occur even if an underflow or overflow occurs in the division.
- If an underflow or overflow occurs in division, the calculation result may not be as expected. Allow sufficient leeway in the sizes of the data types for input and output parameters so that overflows and underflows do not occur.
- Division results of positive infinity, negative infinity, or 0 are handled as follows for real number values.

		In1				
		$+\infty$	Positive number	0	Negative number	$-\infty$
In2	$+\infty$	Nonnumeric data	0	0	0	Nonnumeric data
	Positive number	$+\infty$	Positive number	0	Negative number	$-\infty$
	0	$+\infty$	$+\infty$	Nonnumeric data	$-\infty$	$-\infty$
	Negative number	$-\infty$	Negative number	0	Positive number	$+\infty$
	$-\infty$	Nonnumeric data	0	0	0	Nonnumeric data

- If the value of *In1* or *In2* is nonnumeric data, the value of the division result is nonnumeric data.
- An error occurs in the following case. *ENO* will be FALSE, and *Out* will not change.
 - *In1* and *In2* are integers and the value of *In2* is 0.

MOD

The MOD instruction finds the remainder for division of integers.

Instruction	Name	FB/FUN	Graphic expression	ST expression
MOD	Modulo-division	FUN		Out:=In1 MOD In2;

Variables

Name	Meaning	I/O	Description	Valid range	Unit	Default
In1	Dividend	Input	Dividend	Depends on data type.	---	*
In2	Divisor		Divisor			
Out	Remainder	Output	Remainder	Depends on data type.	---	---

* If you omit an input parameter, the default value is not applied. A building error will occur.

	Boolean	Bit strings					Integers							Real numbers		Times, durations, dates, and text strings				
	BOOL	BYTE	WORD	DWORD	LWORD	USINT	UINT	UDINT	ULINT	SINT	INT	DINT	LINT	REAL	LREAL	TIME	DATE	TOD	DT	STRING
In1						OK	OK	OK	OK	OK	OK	OK	OK							
In2						OK	OK	OK	OK	OK	OK	OK	OK							
Out						OK	OK	OK	OK	OK	OK	OK	OK							

Function

The MOD instruction divides dividend *In1* by divisor *In2* to find the remainder.

The data types of *In1*, *In2*, and remainder *Out* can have different data types. However, use the combination that data types to include are existed.

Refer to *Data Type Ranking Table* and *Casting Rules* in the *NJ/NX-series CPU Unit Software User's Manual* (Cat. No. W501) or *NY-series Industrial Panel PC / Industrial Box PC Software User's Manual* (Cat. No. W558) for the including relationship on data types.

This instruction performs the calculation with the following formula.
 Out = In1 – (In1/In2)* In2 (The decimal point is truncated in the division operation.)
 Examples of the values of *In1*, *In2*, and *Out* are given in the following table.

Value of In1	Value of In2	Value of Out
5	3	2
5	-3	2
-5	3	-2
-5	-3	-2

The following example is for when *In1* is INT#18 and *In2* is INT#5. The value of variable *abc* will be INT#3.

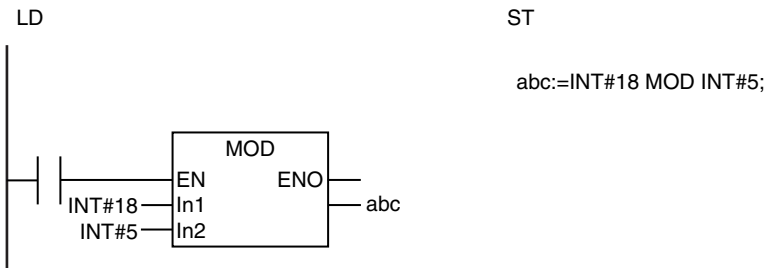

The MOD instruction divides *In1* by *In2* to find the remainder.
The remainder of 18/5 is 3, so the value of *abc* will be INT#3.

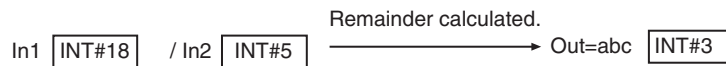

Precautions for Correct Use

- Set the data type of *Out* to include the valid ranges of *In1* and *In2*. Refer to *Data Type Ranking Table* and *Casting Rules* in the *NJ/NX-series CPU Unit Software User's Manual* (Cat. No. W501) or *NY-series Industrial Panel PC / Industrial Box PC Software User's Manual* (Cat. No. W558) for the including relationship on data types.

ABS

The ABS instruction finds the absolute value of an integer or real number.

Instruction	Name	FB/FUN	Graphic expression	ST expression
ABS	Absolute Value	FUN		Out:=ABS(In);

Variables

Name	Meaning	I/O	Description	Valid range	Unit	Default
In	Number to process	Input	Number to process	Depends on data type.	---	*1
Out	Absolute value	Output	Absolute value	Depends on data type. *2	---	---

*1 If you omit an input parameter, the default value is not applied. A building error will occur.

*2 Negative numbers are excluded.

	Boolean	Bit strings					Integers							Real numbers		Times, durations, dates, and text strings				
		BOOL	BYTE	WORD	DWORD	LWORD	USINT	UINT	UDINT	ULINT	SINT	INT	DINT	LINT	REAL	LREAL	TIME	DATE	TOD	DT
In						OK	OK	OK	OK	OK	OK	OK	OK	OK	OK					
Out						OK	OK	OK	OK	OK	OK	OK	OK	OK	OK					

Function

The ABS instruction outputs the absolute value of the number to process *In*. The data types of *In* and absolute value *Out* can have different data types.

The following example is for when *In* is REAL#-10.3. The value of variable *abc* will be REAL#10.3.

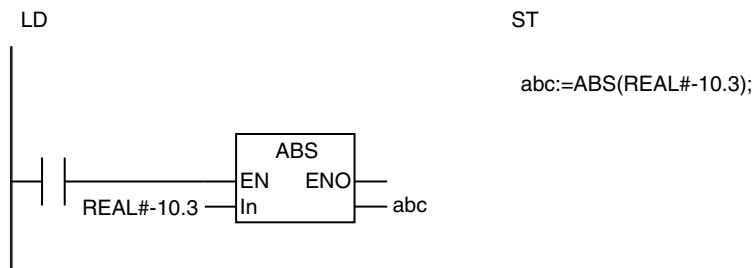

The ABS instruction outputs the absolute value of *In*.
The absolute value of REAL#-10.3 is found, so the value of *abc* will be REAL#10.3.

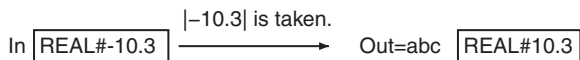

Additional Information

When you calculate real numbers, use the CheckReal instruction (page 2-237) to see if *Out* is positive infinity, negative infinity, or nonnumeric data.

Precautions for Correct Use

- Set the data type of *Out* to include the absolute value of *In*.
- If the value of *In* is positive infinity, negative infinity, or nonnumeric data, the value of *Out* is as shown below.

Value of <i>In</i>	Value of <i>Out</i>
$+\infty$	$+\infty$
$-\infty$	$+\infty$
Nonnumeric data	Nonnumeric data

RadToDeg and DegToRad

RadToDeg: Converts a real number from radians (rad) to degrees (°).

DegToRad: Converts a real number from degrees (°) to radians (rad).

Instruction	Name	FB/FUN	Graphic expression	ST expression
RadToDeg	Radians to Degrees	FUN		Out:=RadToDeg(In);
DegToRad	Degrees to Radians	FUN		Out:=DegToRad(In);

Variables

Name	Meaning	I/O	Description	Valid range	Unit	Default
In	Data to convert	Input	Data to convert	Depends on data type.	<ul style="list-style-type: none"> RadToDeg: Radians DegToRad: Degrees 	*
Out	Conversion result	Output	Conversion result	Depends on data type.	<ul style="list-style-type: none"> RadToDeg: Degrees DegToRad: Radians 	---

* If you omit an input parameter, the default value is not applied. A building error will occur.

	Boolean	Bit strings					Integers							Real numbers		Times, durations, dates, and text strings				
	BOOL	BYTE	WORD	DWORD	LWORD	USINT	UINT	UDINT	ULINT	SINT	INT	DINT	LINT	REAL	LREAL	TIME	DATE	TOD	DT	STRING
In														OK	OK					
Out														OK	OK					

Function

● RadToDeg

The RadToDeg instruction converts the data to convert *In* from radians (rad) to degrees (°). The following conversion is used.

$$\text{Out}=\text{In}\cdot 180/\pi$$

● DegToRad

The DegToRad instruction converts the data to convert *In* from degrees (°) to radians (rad). The following conversion is used.

$$\text{Out}=\text{In}\cdot \pi/180$$

The following example for the DegToRad instruction is for when *In* is REAL#45. The value of the REAL variable *abc* will be REAL#0.785398.

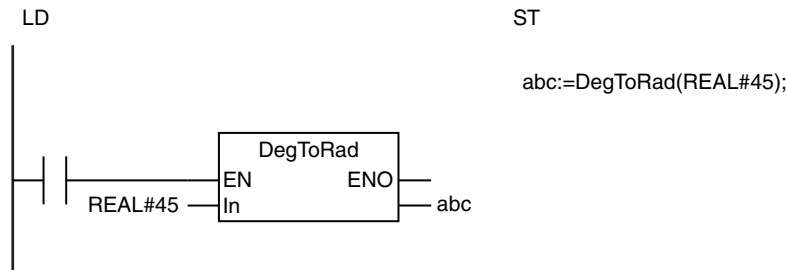

The DegToRad instruction converts the value of *In* from degrees (°) to radians (rad). An angle of 45° is 0.785398 rad, so the value of *abc* will be REAL#0.785398.

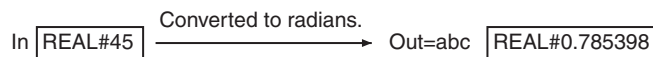

Additional Information

Use the CheckReal instruction (page 2-237) to see if *Out* is positive infinity, negative infinity, or nonnumeric data.

Precautions for Correct Use

- If the absolute value of the conversion result exceeds the maximum value of the data type of *Out*, the value of *Out* will be positive or negative infinity.
- If the absolute value of the conversion result is lower than the minimum value of the data type of *Out*, the value of *Out* will be 0.
- Make sure that the data type of *Out* is equal to or larger than the data type of *In*.
- If the value of *In* is positive infinity, negative infinity, or nonnumeric data, the value of *Out* is as shown below.

Value of <i>In</i>	Value of <i>Out</i>
$+\infty$	$+\infty$
$-\infty$	$-\infty$
Nonnumeric data	Nonnumeric data

- If you pass an integer parameter to *In*, the data type is converted as follows:

Data type of parameter that is passed to <i>In</i>	Data type of <i>In</i>
USINT, UINT, SINT, or INT	REAL
UDINT or DINT	LREAL
ULINT or LINT	A building error will occur.

SIN, COS, and TAN

These instructions perform trigonometric calculations on real numbers.

SIN: Finds the sine of a number.

COS: Finds the cosine of a number.

TAN: Finds the tangent of a number.

Instruction	Name	FB/FUN	Graphic expression	ST expression
SIN	Sine in Radians	FUN		Out:=SIN(In);
COS	Cosine in Radians	FUN		Out:=COS(In);
TAN	Tangent in Radians	FUN		Out:=TAN(In);

Variables

Name	Meaning	I/O	Description	Valid range	Unit	Default
In	Number to process	Input	Number to process	Depends on data type.	Radians	*1
Out	Calculation result	Output	Calculation result	<ul style="list-style-type: none"> SIN*2 COS*2 TAN Depends on data type.	---	---

*1 If you omit an input parameter, the default value is not applied. A building error will occur.

*2 The valid range is $-1.000000e+0$ to $1.000000e+0$ for REAL data. The valid range is $-1.00000000000000e+0$ to $1.00000000000000e+0$ for LREAL data.

	Boolean	Bit strings					Integers							Real numbers		Times, durations, dates, and text strings				
	BOOL	BYTE	WORD	DWORD	LWORD	USINT	UINT	UDINT	ULINT	SINT	INT	DINT	LINT	REAL	LREAL	TIME	DATE	TOD	DT	STRING
In														OK	OK					
Out														OK	OK					

Function

These instructions perform trigonometric calculations on real numbers. Number to process In is an angle in radians (rad).

● SIN

The SIN instruction finds the sine of In .

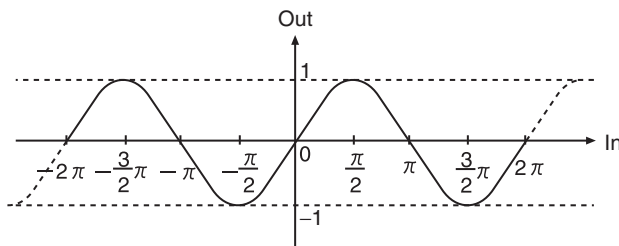

● COS

The COS instruction finds the cosine of In .

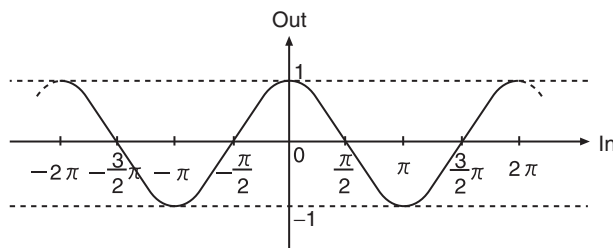

● TAN

The TAN instruction finds the tangent of In .

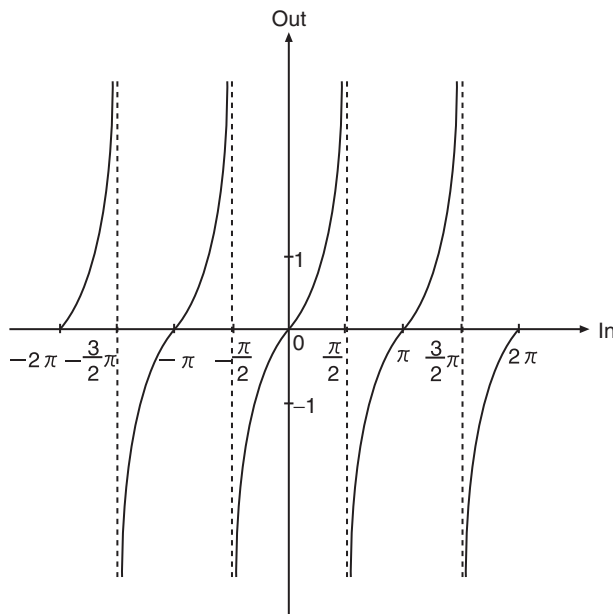

The following example for the COS instruction is for when *In* is REAL#3.141592. The value of variable *abc* will be REAL#-1.0.

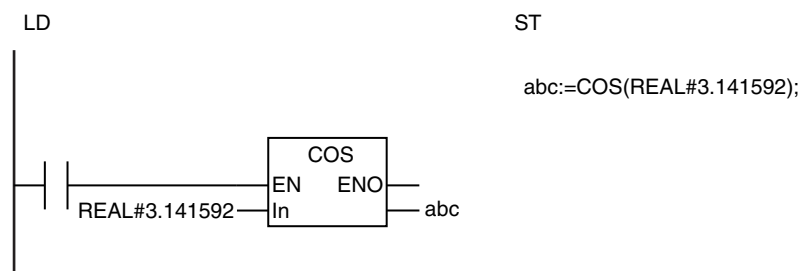

The COS instruction finds the cosine of *In*.
The cosine of 3.141592 is -1.0, so the value of *abc* will be REAL#-1.0.

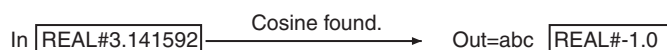

Additional Information

- Use the RadToDeg and DegToRad instructions (page 2-196) to convert between degrees and radians.
- If *In* for the TAN instruction is $n\pi/2$, when *n* is an integer, then the value of *Out* will be positive or negative infinity. Use the CheckReal instruction (page 2-237) to see if the value of *Out* is positive infinity or negative infinity.

Precautions for Correct Use

- If the value of *In* is positive infinity, negative infinity, or nonnumeric data, the value of *Out* is nonnumeric data.
- If you pass an integer parameter to *In*, the data type is converted as follows:

Data type of parameter that is passed to <i>In</i>	Data type of <i>In</i>
USINT, UINT, SINT, or INT	REAL
UDINT or DINT	LREAL
ULINT or LINT	A building error will occur.

ASIN, ACOS, and ATAN

These instructions perform inverse trigonometric calculations on real numbers.

ASIN: Finds the arc sine of a number.

ACOS: Finds the arc cosine of a number.

ATAN: Finds the arc tangent of a number.

Instruction	Name	FB/FUN	Graphic expression	ST expression
ASIN	Principal Arc Sine	FUN		Out:=ASIN(In);
ACOS	Principal Arc Cosine	FUN		Out:=ACOS(In);
ATAN	Principal Arc Tangent	FUN		Out:=ATAN(In);

Variables

Name	Meaning	I/O	Description	Valid range	Unit	Default
In	Number to process	Input	Number to process	Depends on data type.	---	*
Out	Calculation result	Output	Calculation result	<ul style="list-style-type: none"> ASIN $-\pi/2$ to $\pi/2$ ACOS 0 to π ATAN $-\pi/2$ to $\pi/2$ 	rad	---

* If you omit the input parameter, the default value is not applied. A building error will occur.

	Boolean	Bit strings					Integers						Real numbers		Times, durations, dates, and text strings					
	BOOL	BYTE	WORD	DWORD	LWORD	USINT	UINT	UDINT	ULINT	SINT	INT	DINT	LINT	REAL	LREAL	TIME	DATE	TOD	DT	STRING
In														OK	OK					
Out														OK	OK					

Function

These instructions perform inverse trigonometric calculations on real numbers. The calculation result *Out* is an angle in radians (rad).

● ASIN

The ASIN instruction finds the arc sine of *In*. *Out* is between $-\pi/2$ and $\pi/2$.

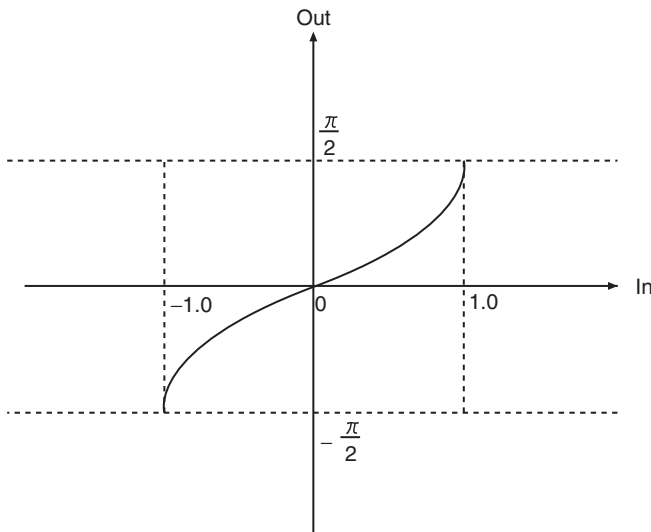

● **ACOS**

The ACOS instruction finds the arc cosine of *In*. *Out* is between 0 and π .

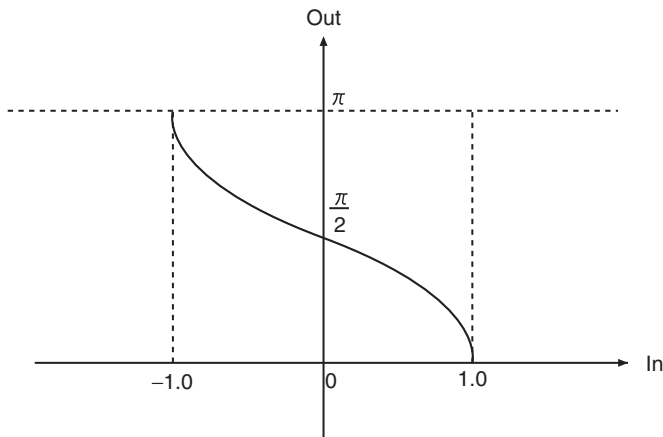

● **ATAN**

The ATAN instruction finds the arc tangent of *In*. *Out* is between $-\pi/2$ and $\pi/2$.

If the value of *In* is positive infinity, the value of *Out* is $\pi/2$. If the value of *In* is negative infinity, the value of *Out* is $-\pi/2$.

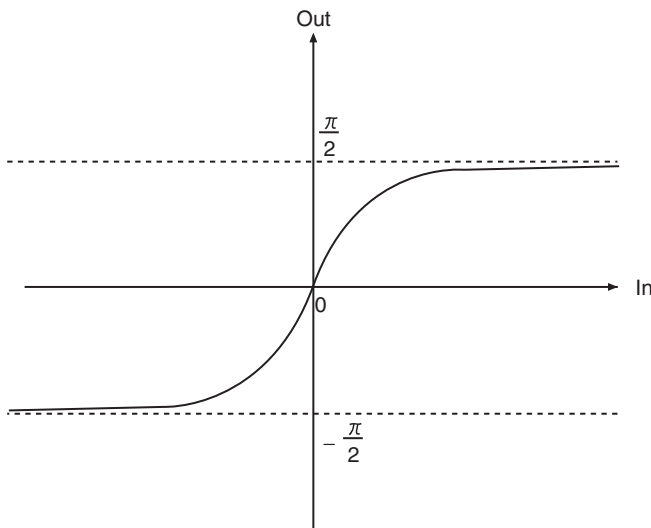

The following example for the ACOS instruction is for when In is REAL#-1.0. The value of variable abc will be REAL#3.141592.

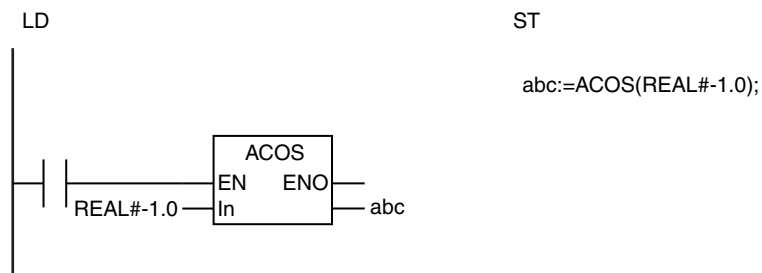

The ACOS instruction finds the arccosine of In .
The arccosine of -1.0 is 3.141592, so the value of abc will be REAL#3.141592.

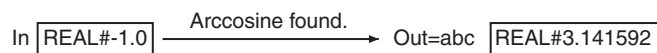

Additional Information

Use the RadToDeg and DegToRad instructions (page 2-196) to convert between degrees and radians.

Precautions for Correct Use

- If In is not between -1.0 and 1.0 for the ASIN or ACOS instruction, the value of Out is nonnumeric data. That also applies when the value of In is negative infinity, positive infinity, or nonnumeric data.
- If the value of In is nonnumeric data for the ATAN instruction, the value of Out is nonnumeric data.
- If you pass an integer parameter to In , the data type is converted as follows:

Data type of parameter that is passed to In	Data type of In
USINT, UINT, SINT, or INT	REAL
UDINT or DINT	LREAL
ULINT or LINT	A building error will occur.

SQRT

The SQRT instruction finds the square root of a number.

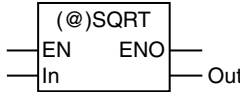
Instruction	Name	FB/FUN	Graphic expression	ST expression
SQRT	Square Root	FUN		Out:=SQRT(In);

Variables

Name	Meaning	I/O	Description	Valid range	Unit	Default
In	Number to process	Input	Number to process	Depends on data type. *1	---	*2
Out	Square root	Output	Square root	*3	---	---

*1 Negative numbers are excluded.

*2 If you omit an input parameter, the default value is not applied. A building error will occur.

*3 The valid range is 0.000000e+00 to 1.844674e+19 or positive infinity for REAL data. The valid range is 0.000000000000000e+000 to 1.34078079299425e+154 or positive infinity for LREAL data.

	Boolean	Bit strings					Integers							Real numbers		Times, durations, dates, and text strings				
	BOOL	BYTE	WORD	DWORD	LWORD	USINT	UINT	UDINT	ULINT	SINT	INT	DINT	LINT	REAL	LREAL	TIME	DATE	TOD	DT	STRING
In														OK	OK					
Out														OK	OK					

Function

The SQRT instruction finds the square root of number to process *In*. The data types of *In* and square root *Out* can have different data types.

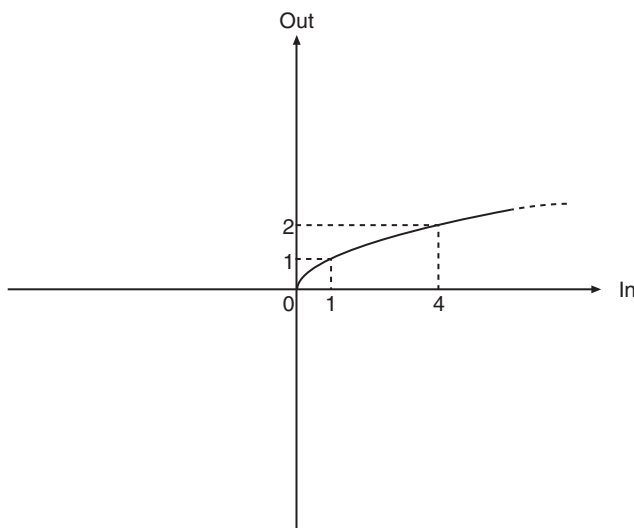

The following example is for when *In* is REAL#16.0. The value of variable *abc* will be REAL#4.0.

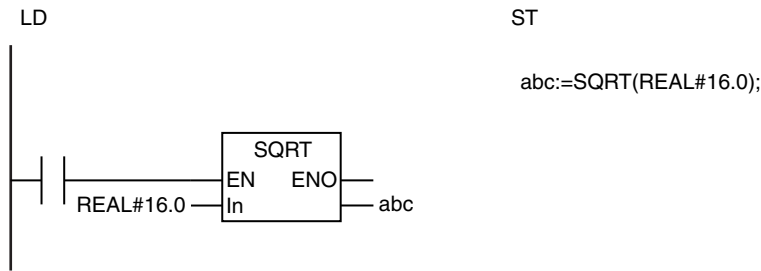

The SQRT instruction finds the square root of *In*. The square root of 16.0 is 4.0, so the value of *abc* will be REAL#4.0.

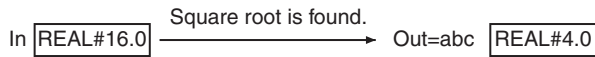

Additional Information

Use the CheckReal instruction (page 2-237) to see if the value of *Out* is positive infinity.

Precautions for Correct Use

- If the value of *In* is not a positive number, the value of *Out* is as shown below.

Value of <i>In</i>	Value of <i>Out</i>
Negative number	Nonnumeric data
0	0
+∞	+∞
-∞	Nonnumeric data
Nonnumeric data	Nonnumeric data

- If you pass an integer parameter to *In*, the data type is converted as follows:

Data type of parameter that is passed to <i>In</i>	Data type of <i>In</i>
USINT, UINT, SINT, or INT	REAL
UDINT or DINT	LREAL
ULINT or LINT	A building error will occur.

LN and LOG

These instructions find the logarithm of a real number.

LN: Finds the natural logarithm of a number.

LOG: Finds the base-10 logarithm of a number.

Instruction	Name	FB/FUN	Graphic expression	ST expression
LN	Natural Logarithm	FUN		Out:=LN(In);
LOG	Logarithm Base 10	FUN		Out:=LOG(In);

Variables

Name	Meaning	I/O	Description	Valid range	Unit	Default
In	Number to process	Input	Number to process	Depends on data type. *1	---	*2
Out	Logarithm	Output	Logarithm	*3	---	---

*1 Negative numbers are excluded.

*2 If you omit an input parameter, the default value is not applied. A building error will occur.

*3 LN:

If *In* and *Out* are REAL data: $-8.73365448e+1$ to $8.87228390e+1$, or $-\infty/+ \infty$

If *In* is REAL and *Out* is LREAL data: $-8.7336544750000000e+1$ to $8.8722839050000000e+1$ or $-\infty/+ \infty$

If *In* is LREAL and *Out* is REAL data: $-7.08384950e+2$ to $7.09782712e+2$ or $-\infty/+ \infty$

If *In* and *Out* are LREAL data: $-7.0838495021978327e+1$ to $7.0978271289338399e+2$ or $-\infty/+ \infty$

LOG:

If *In* and *Out* are REAL data: $-3.79297795e+1$ to $3.85318394e+1$ or $-\infty/+ \infty$

If *In* is REAL and *Out* is LREAL data: $-3.7929779453965430e+1$ to $3.8531839419564961e+1$ or $-\infty/+ \infty$

If *In* is LREAL and *Out* is REAL data: $-3.07652656e+2$ to $3.08254716e+2$ or $-\infty/+ \infty$

If *In* and *Out* are LREAL data: $-3.0765265556858878e+2$ to $3.0825471555991674e+2$ or $-\infty/+ \infty$

	Boolean	Bit string					Integers							Real numbers		Times, durations, dates, and text strings				
	BOOL	BYTE	WORD	DWORD	LWORD	USINT	UINT	UDINT	ULINT	SINT	INT	DINT	LINT	REAL	LREAL	TIME	DATE	TOD	DT	STRING
In														OK	OK					
Out														OK	OK					

The LOG instruction finds the base-10 logarithm of a real number.
 The base-10 logarithm of 1,000.0 is 3.0 so the value of *abc* will be REAL#3.0.

In REAL#1000.0 $\xrightarrow{\text{Common logarithm is taken.}}$ Out=abc REAL#3.0

Additional Information

Use the CheckReal instruction (page 2-237) to see if *Out* is positive infinity, negative infinity, or nonnumeric data.

Precautions for Correct Use

- If the value of *In* is not a positive number, the value of *Out* is as shown below.

Value of <i>In</i>	Value of <i>Out</i>
Negative number	Nonnumeric data
0	$-\infty$
$+\infty$	$+\infty$
$-\infty$	Nonnumeric data
Nonnumeric data	Nonnumeric data

- If you pass an integer parameter to *In*, the data type is converted as follows:

Data type of parameter that is passed to <i>In</i>	Data type of <i>In</i>
USINT, UINT, SINT, or INT	REAL
UDINT or DINT	LREAL
ULINT or LINT	A building error will occur.

EXP

The EXP instruction performs calculations for the natural exponential function.

Instruction	Name	FB/FUN	Graphic expression	ST expression
EXP	Natural Exponential Operation	FUN		Out:=EXP(In);

Variables

Name	Meaning	I/O	Description	Valid range	Unit	Default
In	Exponent	Input	Exponent	Depends on data type.	---	*1
Out	Calculation result	Output	Calculation result	Depends on data type. *2	---	---

*1 If you omit an input parameter, the default value is not applied. A building error will occur.

*2 Negative numbers are excluded.

	Boolean	Bit strings				Integers							Real numbers		Times, durations, dates, and text strings					
	BOOL	BYTE	WORD	DWORD	LWORD	USINT	UINT	UDINT	ULINT	SINT	INT	DINT	LINT	REAL	LREAL	TIME	DATE	TOD	DT	STRING
In														OK	OK					
Out														OK	OK					

Function

The EXP instruction returns the value of e^{In} , where e is Euler's constant and In is an input variable.

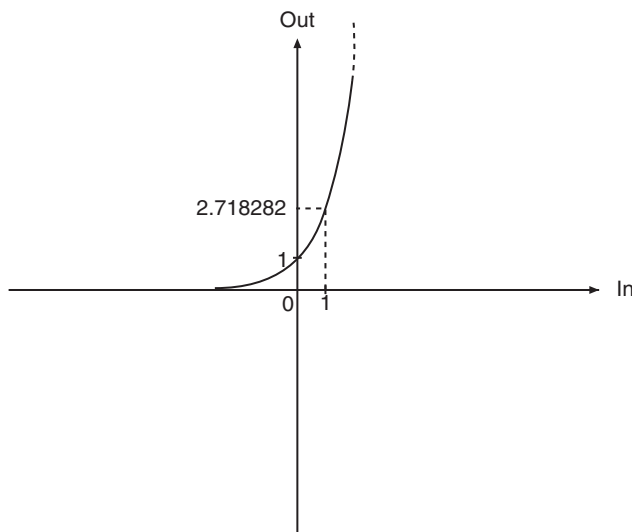

The following example is for when *In* is REAL#1.0. The value of variable *abc* will be REAL#2.718282.

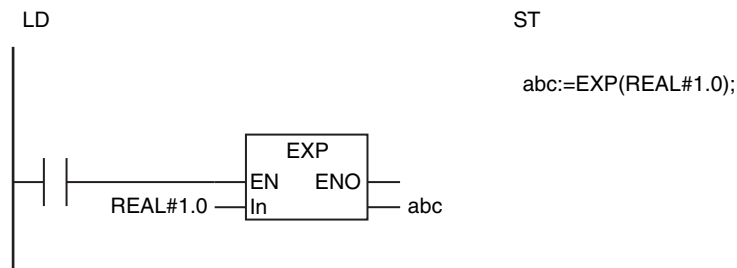

The EXP instruction returns the natural logarithm of *In* to the base e.
The value of e¹ is 2.718282, so the value of *abc* will be REAL#2.718282.

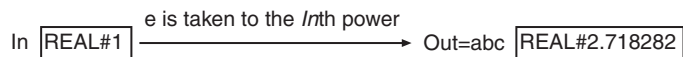

Additional Information

- Use the EXPT (**) instruction (page 2-211) to find the powers of numbers with bases other than e.
- Use the CheckReal instruction (page 2-237) to see if *Out* is positive infinity, negative infinity, or non-numeric data.

Precautions for Correct Use

- If the value of *In* is 0.0, positive infinity, negative infinity, or nonnumeric data, the value of *Out* is as shown below.

Value of <i>In</i>	Value of <i>Out</i>	
	Other than the right	NX1P2
0	1.0	1.0
+∞	Nonnumeric data	+∞
-∞	Nonnumeric data	0.0
Nonnumeric data	Nonnumeric data	Nonnumeric data

- If you pass an integer parameter to *In*, the data type is converted as follows:

Data type of parameter that is passed to <i>In</i>	Data type of <i>In</i>
USINT, UINT, SINT, or INT	REAL
UDINT or DINT	LREAL
ULINT or LINT	A building error will occur.

EXPT (**)

The EXPT (**) instruction raises one real number to the power of another real number.

Instruction	Name	FB/FUN	Graphic expression	ST expression
EXPT (**)	Exponentiation	FUN		Out:=EXPT(In, Pwr); Out:=In ** Pwr;

Variables

Name	Meaning	I/O	Description	Valid range	Unit	Default
In	Base number	Input	Base number (e.g., 5 for 5 ²)	Depends on data type.	---	*
Pwr	Exponent		Exponent (e.g., 2 for 5 ²)			
Out	Calculation result	Output	Calculation result	Depends on data type.	---	---

* If you omit an input parameter, the default value is not applied. A building error will occur.

The Instruction of LD and the EXPT Instruction in ST

	Boolean	Bit strings					Integers						Real numbers		Times, durations, dates, and text strings					
	BOOL	BYTE	WORD	DWORD	LWORD	USINT	UINT	UDINT	ULINT	SINT	INT	DINT	LINT	REAL	LREAL	TIME	DATE	TOD	DT	STRING
In														OK	OK					
Pwr														OK	OK					
Out														OK	OK					

The ** Operator in ST

	Boolean	Bit strings					Integers							Real numbers		Times, durations, dates, and text strings				
	BOOL	BYTE	WORD	DWORD	LWORD	USINT	UINT	UDINT	ULINT	SINT	INT	DINT	LINT	REAL	LREAL	TIME	DATE	TOD	DT	STRING
In						OK	OK	OK	OK	OK	OK	OK	OK	OK	OK					
Pwr						OK	OK	OK	OK	OK	OK	OK	OK	OK	OK					
Out						OK	OK	OK	OK	OK	OK	OK	OK	OK	OK					

Function

The EXPT (**) instruction raises base number *In* to exponent *Pwr* to find In^{Pwr} .

The following example is for when *In* is REAL#10.0 and *Pwr* is REAL#3.0. The value of variable *abc* will be REAL#1000.0.

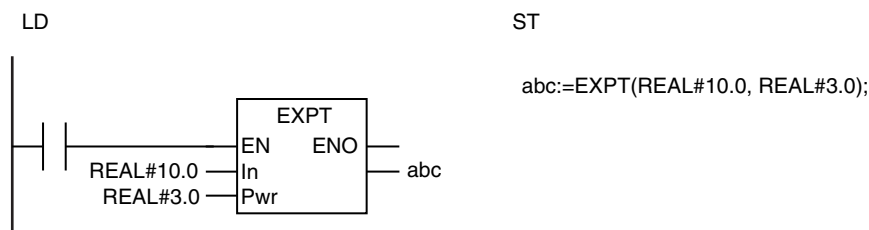

The ACOS instruction finds *In* to the power of *Pwr*.
 $10.0^{3.0}$ is 1,000.0, so the value of *abc* will be REAL#1000.0.

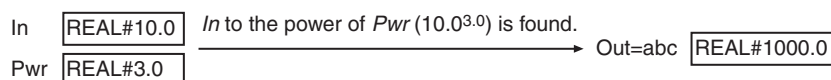

Difference in Specifications between Ladder Diagrams and ST

Specifications of this instruction depend on whether it is used in a ladder diagram or the ** operator is used in ST. The following table gives the differences in specifications. The specifications of the EXPT instruction and the ** instruction of ladder diagrams and the EXPT function of ST are exactly the same.

Item	EXPT functions in ladder diagrams and ST	** operator in ST
Existence of the <i>EN</i> and <i>ENO</i> variables	Present	None
Number of data processing bits if <i>In</i> and <i>Pwr</i> are integer data	32 or 64 *1	64*2

- *1. Operation is performed with the smaller real number included, from either REAL or LREAL data. For example, if you operate SINT and DINT data, the data processing bits will be aligned to the size of LREAL data, i.e., 64-bit processing is performed.
- *2. 64-bit processing is performed. For example, if two SINT values are exponentiated, 64-bit processing is performed.

Additional Information

- Use the EXP instruction (page 2-209) to find powers of base e.
- Use the CheckReal instruction (page 2-237) to see if *Out* is positive infinity, negative infinity, or non-numeric data.

Precautions for Correct Use

- If the absolute value of the calculation result is lower than the minimum value for a real number, the value of *Out* will be 0.

Example: $(1.175494e-38)^2 \rightarrow 0$

- An error will not occur even if an underflow or overflow occurs in the calculation when the ** operator is used.
- If an underflow or overflow occurs in the calculation when the ** operator is used, the calculation result may not be as expected. Allow sufficient leeway in the sizes of the data types for input and output parameters so that overflows and underflows do not occur.
- For the EXPT instruction and ** instruction of ladder diagrams and the EXPT function of ST, if you pass an integer parameter to *In*, the data type is converted as follows:

Data type of parameter that is passed to <i>In</i>	Data type of <i>In</i>
USINT, UINT, SINT, or INT	REAL
UDINT or DINT	LREAL
ULINT or LINT	A building error will occur.

- When the ** operator is used, if you select the version 1.15 or earlier in the Select Device Area of the Project Properties Dialog Box on the Sysmac Studio for an NX701 CPU Unit, NJ-series CPU Unit and NY-series Controller, integer variables are calculated as real number variables even if they set as operands.

If a rounding error is included in the result of calculations, the result may not be an intended value because all values after the decimal point are truncated.

Use the EXPT and TO_** (Integer Conversion Group) instructions together to round values after the decimal point.

Example) TO_INT (EXPT(X,Y))

Combination of *In* and *Pwr* values

The following table shows the values of *Out* for different combinations of *In* and *Pwr* values.

● The EXPT Function for a Device Other Than the NX1P2 CPU Unit

		In									
		+∞	1 to +∞	1	0 to 1	0	-1 to 0	-1	-1 to -∞	-∞	Non-numeric data
Pwr	+∞	+∞	+∞	1	0	1	0	1	+∞	1	Nonnumeric data
	Positive even number						Number ^{*1*2}	1	Number ^{*1*2}		Nonnumeric data
	Positive odd number	+∞	Number ^{*1*2}	1	Number ^{*1*2}	0	Number ^{*2*3}	-1	Number ^{*2*3}	+∞	
	Positive decimal number				Nonnumeric data						
	0	1	1			1	1			1	1
	Negative even number						Number ^{*1*2}	1	Number ^{*1*2}		Nonnumeric data
	Negative odd number	0	Number ^{*1*2}	1	Number ^{*1*2}	+∞	Number ^{*2*3}	-1	Number ^{*2*3}	0	
	Negative decimal number				Nonnumeric data						
	-∞	0	0	1	+∞	+∞	+∞	1	0	0	Nonnumeric data
	Nonnumeric data	1	Nonnumeric data	1	Nonnumeric data	1	Nonnumeric data			1	Nonnumeric data 1

- *1. If the calculation result exceeds the valid range of the data type of *Out*, the value of *Out* will be positive infinity.
- *2. If the calculation result is too close to 0 to express with the data type of *Out* or if it is an unnormalized number, the value of *Out* will be 0.
- *3. If the calculation result exceeds the valid range of the data type of *Out*, the value of *Out* will be negative infinity.

● The EXPT Function for the NX1P2 CPU Unit

		In									
		$+\infty$	1 to $+\infty$	1	0 to 1	0	-1 to 0	-1	-1 to $-\infty$	$-\infty$	Non-numeric data
Pwr	$+\infty$	$+\infty$	$+\infty$	1	0	1	0	1	$+\infty$	1	Nonnumeric data
	Positive even number		Number ^{*1*2}	1	Number ^{*1*2}	0	Number ^{*1*2}	1	Number ^{*1*2}	$+\infty$	Nonnumeric data
	Positive odd number	$+\infty$	Number ^{*1*2}	1	Number ^{*1*2}	0	Number ^{*2*3}	-1	Number ^{*2*3}	$-\infty$	
	Positive decimal number						Nonnumeric data			$+\infty$	
	0	1	1			1	1			1	1
	Negative even number		Number ^{*1*2}	1	Number ^{*1*2}	$+\infty$	Number ^{*1*2}	1	Number ^{*1*2}	0	Nonnumeric data
	Negative odd number	0	Number ^{*1*2}	1	Number ^{*1*2}	$+\infty$	Number ^{*2*3}	-1	Number ^{*2*3}	-0	
	Negative decimal number						Nonnumeric data			0	
	$-\infty$	0	0	1	$+\infty$	$+\infty$	$+\infty$	1	0	0	Nonnumeric data
	Nonnumeric data	1	Nonnumeric data	1	Nonnumeric data	1	Nonnumeric data			1	Nonnumeric data 1

- *1. If the calculation result exceeds the valid range of the data type of *Out*, the value of *Out* will be positive infinity.
- *2. If the calculation result is too close to 0 to express with the data type of *Out* or if it is an unnormalized number, the value of *Out* will be 0.
- *3. If the calculation result exceeds the valid range of the data type of *Out*, the value of *Out* will be negative infinity.

● The ** Operator

		In									
		$+\infty$	1 to $+\infty$	1	0 to 1	0	-1 to 0	-1	-1 to $-\infty$	$-\infty$	Non-numeric data
Pwr	$+\infty$	$+\infty$	$+\infty$	1	0	1	0	1	$+\infty$	1	Nonnumeric data
	Positive even number						Number ^{*1*2}	1	Number ^{*1*2*3}	$+\infty$	Nonnumeric data
	Positive odd number	$+\infty$	Number ^{*1*2*3}	1	Number ^{*1*2}	0	Number ^{*2*4}	-1	Number ^{*2*3*4}	$-\infty$	
	Positive decimal number	Nonnumeric data							$+\infty$		
	0	1	1			1	1			1	1
	Negative even number						Number ^{*1*2}	1	Number ^{*1*2}	0	Nonnumeric data
	Negative odd number	0	Number ^{*1*2}	1	Number ^{*1*2}	$+\infty$ ^{*5}	Number ^{*2*4}	-1	Number ^{*2*4}	-0	
	Negative decimal number	Nonnumeric data							0		
	$-\infty$	0	0	1	$+\infty$	$+\infty$	$+\infty$	1	0	0	Nonnumeric data
	Nonnumeric data	1	Nonnumeric data			1	Nonnumeric data			1	Nonnumeric data 1

- *1. If the calculation result exceeds the valid range of the data type of *Out*, the value of *Out* will be positive infinity.
- *2. If the calculation result is too close to 0 to express with the data type of *Out* or if it is an unnormalized number, the value of *Out* will be 0.
- *3. When both *In* and *Pwr* are integer data, if the calculation result exceeds the valid range of the data type of *Out*, *Out* will contain an undefined value.
- *4. If the calculation result exceeds the valid range of the data type of *Out*, the value of *Out* will be negative infinity.
- *5. When both *In* and *Pwr* are integer data, *Out* will contain an undefined value.

Inc and Dec

Inc: Increments an integer value.

Dec: Decrements an integer value.

Instruction	Name	FB/FUN	Graphic expression	ST expression
Inc	Increment	FUN		Inc(InOut);
Dec	Decrement	FUN		Dec(InOut);

Variables

Name	Meaning	I/O	Description	Valid range	Unit	Default
InOut	Target data	In-out	Target data	Depends on data type.	---	---
Out	Return value	Output	Always TRUE	TRUE only	---	---

	Boolean	Bit strings				Integers							Real numbers		Times, durations, dates, and text strings					
	BOOL	BYTE	WORD	DWORD	LWORD	USINT	UINT	UDINT	ULINT	SINT	INT	DINT	LINT	REAL	LREAL	TIME	DATE	TOD	DT	STRING
InOut						OK	OK	OK	OK	OK	OK	OK	OK							
Out	OK																			

Function

● Inc

The Inc instruction increments target data *InOut*. If the result exceeds the maximum value of *InOut*, *InOut* returns to the minimum value.

● Dec

The Dec instruction decrements target data *InOut*. If the result exceeds the minimum value of *InOut*, *InOut* returns to the maximum value.

The following example for the Inc instruction is for when variable *abc* is passed to *InOut*. If the value of *abc* is INT#4, the value of *abc* after the instruction is executed will be INT#5.

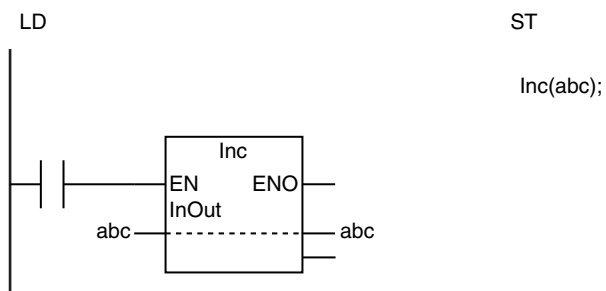

The Inc instruction increments *InOut*.
 If the value of *abc* is INT#4, the value of *abc* after the instruction is executed will be INT#5.



Precautions for Correct Use

Return value *Out* is not used when the instruction is used in ST.

Rand

The Rand instruction generates pseudorandom numbers.

Instruction	Name	FB/FUN	Graphic expression	ST expression
Rand	Random Number	FB		Rand_instance(Execute, Seed, Rnd);

Variables

Name	Meaning	I/O	Description	Valid range	Unit	Default
Seed	Random number pattern	Input	Random number pattern 0: Not specified	Depends on data type.	---	*1
Rnd	Random number	Output	Random number	*2	---	---

*1 If you omit the input parameter, the value will be 0. It will not be the value that is specified for the Initial Value attribute.

*2 0.0000000000000e+0 to 1.0000000000000e+0

	Boolean	Bit strings				Integers							Real numbers	Times, durations, dates, and text strings						
	BOOL	BYTE	WORD	DWORD	LWORD	USINT	UINT	UDINT	ULINT	SINT	INT	DINT	LINT	REAL	LREAL	TIME	DATE	TOD	DT	STRING
Seed							OK													
Rnd														OK						

Function

The Rand instruction specifies random number *Rnd*. The value of *Rnd* is different each time the instruction is executed: Random number pattern *Seed* specifies the random number system. If the value of *Seed* is the same, the same random number series is generated each time the power supply is turned ON. This allows you to generate a repeatable series of random numbers.

If the value of *Seed* is 0, random numbers that cannot be repeated are generated. If you do not want to generate the same series of random numbers each time the power supply is turned ON, set the value of *Seed* to 0.

The following programming example is for when *Seed* is UINT#1. The value of *Seed* is not 0, so random numbers that can be repeated are generated.

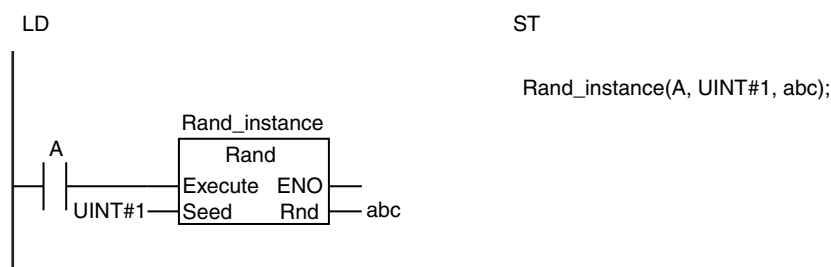

The Rand instruction generates a repeatable series of random numbers.

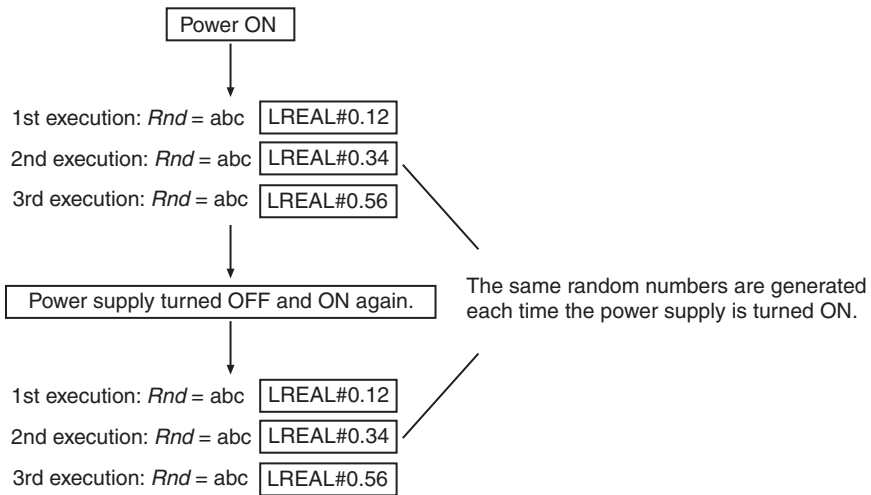

* The values of the random numbers that are given above are examples. The actual values will be different.

Additional Information

The value of *Rnd* is a real number between 0 and 1. Use the following processing to generate random numbers within a specific range.

Example: The following formula generates random numbers between 100 and 200.

```
Rand_instance(A, UINT#1, abc);
```

```
Random number:=LREAL_TO_INT((200.0-100.0)*abc)+100;
```

AryAdd

The AryAdd instruction adds corresponding elements of two arrays.

Instruction	Name	FB/FUN	Graphic expression	ST expression
AryAdd	Array Addition	FUN	<pre> (@)AryAdd --- EN ENO --- --- In1 --- In2 --- Size --- AryOut --- </pre>	AryAdd(In1, In2, Size, AryOut);

Variables

Name	Meaning	I/O	Description	Valid range	Unit	Default
In1[] (array) and In2[] (array)	Array to process	Input	Array to process	Depends on data type.	---	*
Size	Number of elements to process		Number of elements to process			1
AryOut[] (array)	Calculation results array	In-out	Calculation results array	Depends on data type.	---	---
Out	Return value	Output	Always TRUE	TRUE only	---	---

* If you omit an input parameter, the default value is not applied. A building error will occur.

	Boolean	Bit strings				Integers							Real numbers	Times, durations, dates, and text strings						
	BOOL	BYTE	WORD	DWORD	LWORD	USINT	UINT	UDINT	ULINT	SINT	INT	DINT	LINT	REAL	LREAL	TIME	DATE	TOD	DT	STRING
In1[] (array)						OK	OK	OK	OK	OK	OK	OK	OK	OK						
In2[] (array)	Must be an array with the same data type as In1[].																			
Size							OK													
AryOut[] (array)	Must be an array with the same data type as In1[].																			
Out	OK																			

Function

The AryAdd instruction adds *Size* elements of arrays to process *In1[]* and *In2[]* starting from *In1[0]* and *In2[0]*. The results are assigned to corresponding elements of calculation results array *AryOut[]*.

The following example is for when *Size* is *UINT#3*.

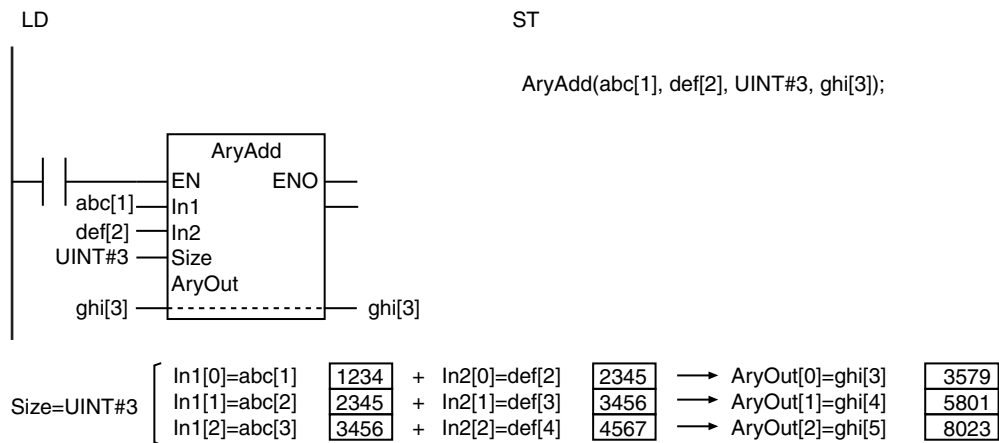

Precautions for Correct Use

- Use the same data type for *In1[]*, *In2[]*, and *AryOut[]*. If they are different, a building error will occur.
- If the calculation results exceed the valid range of *AryOut[]*, the results will be illegal values. An error will not occur. Corruption will not occur in the data in the memory area adjacent to those elements.
- The values in *AryOut[]* do not change if the value of *Size* is 0.
- Return value *Out* is not used when the instruction is used in ST.
- An error occurs in the following cases. *ENO* will be FALSE, and *AryOut[]* will not change.
 - The value of *Size* exceeds the array range of *In1[]*, *In2p[]*, or *AryOut[]*.

AryAddV

The AryAddV instruction adds the same value to specified elements of an array.

Instruction	Name	FB/FUN	Graphic expression	ST expression
AryAddV	Array Value Addition	FUN		AryAddV(In1, In2, Size, AryOut);

Variables

Name	Meaning	I/O	Description	Valid range	Unit	Default
In1[] (array)	Addition array	Input	Addition array	Depends on data type.	---	*
In2	Value to add		Value to add			1
Size	Number of elements		Number of elements of <i>In1[]</i> for addition			
AryOut[] (array)	Addition results array	In-out	Addition results array	Depends on data type.	---	---
Out	Return value	Output	Always TRUE	TRUE only	---	---

* If you omit an input parameter, the default value is not applied. A building error will occur.

	Boolean	Bit string				Integers							Real numbers	Times, durations, dates, and text strings						
	BOOL	BYTE	WORD	DWORD	LWORD	USINT	UINT	UDINT	ULINT	SINT	INT	DINT	LINT	REAL	LREAL	TIME	DATE	TOD	DT	STRING
In1[] (array)						OK	OK	OK	OK	OK	OK	OK	OK	OK	OK					
In2	Must be same data type as <i>In1[]</i> .																			
Size						OK														
AryOut[] (array)	Must be same data type as <i>In1[]</i> .																			
Out	OK																			

Function

The AryAddV instruction adds value to add *In2* to *Size* elements of addition array *In1[]* starting from *In1[0]*. It outputs the results to addition results array *AryOut[]*.

The following example is for when *In2* is INT#11 and *Size* is UINT#3.

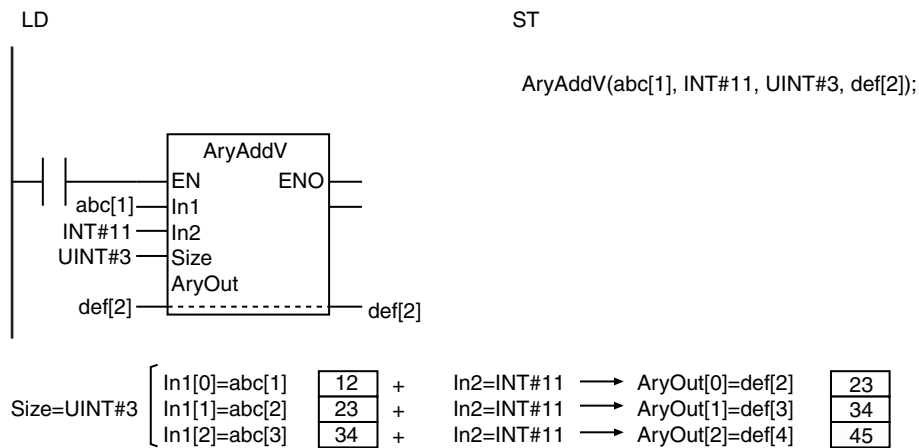

Precautions for Correct Use

- Use the same data type for *In1[]*, *In2*, and *AryOut[]*. If they are different, a building error will occur.
- If the addition results exceed the valid range of *AryOut[]*, the elements of *AryOut[]* will contain illegal values. An error will not occur. Corruption will not occur in the data in the memory area adjacent to those elements.
- The values in *AryOut[]* do not change if the value of *Size* is 0.
- Return value *Out* is not used when the instruction is used in ST.
- An error occurs in the following cases. *ENO* will be FALSE, and *AryOut[]* will not change.
 - If the value of *Size* exceeds the array area of *In1[]* or *AryOut[]*.

ArySub

The ArySub instruction subtracts corresponding elements of two arrays.

Instruction	Name	FB/FUN	Graphic expression	ST expression
ArySub	Array Subtraction	FUN		ArySub(In1, In2, Size, AryOut);

Variables

Name	Meaning	I/O	Description	Valid range	Unit	Default
In1[] (array)	Minuend array	Input	Minuend array	Depends on data type.	---	*
In2[] (array)	Subtrahend array		Subtrahend array			
Size	Number of elements		Number of elements for subtraction			
AryOut[] (array)	Subtraction results array	In-out	Subtraction results array	Depends on data type.	---	---
Out	Return value	Output	Always TRUE	TRUE only	---	---

* If you omit an input parameter, the default value is not applied. A building error will occur.

	Boolean	Bit string				Integers							Real numbers	Times, durations, dates, and text strings						
	BOOL	BYTE	WORD	DWORD	LWORD	USINT	UINT	UDINT	ULINT	SINT	INT	DINT	LINT	REAL	LREAL	TIME	DATE	TOD	DT	STRING
In1[] (array)						OK	OK	OK	OK	OK	OK	OK	OK	OK						
In2[] (array)	Must be same data type as In1[].																			
Size						OK														
AryOut[] (array)	Must be same data type as In1[].																			
Out	OK																			

Function

The ArySub instruction subtracts Size elements of subtrahend array *In2[]* from corresponding elements of minuend array *In1[]* starting with *In1[0]* and *In2[0]*. It outputs the subtraction results to subtraction results array *AryOut[]*.

The following example is for when *Size* is *UINT#3*.

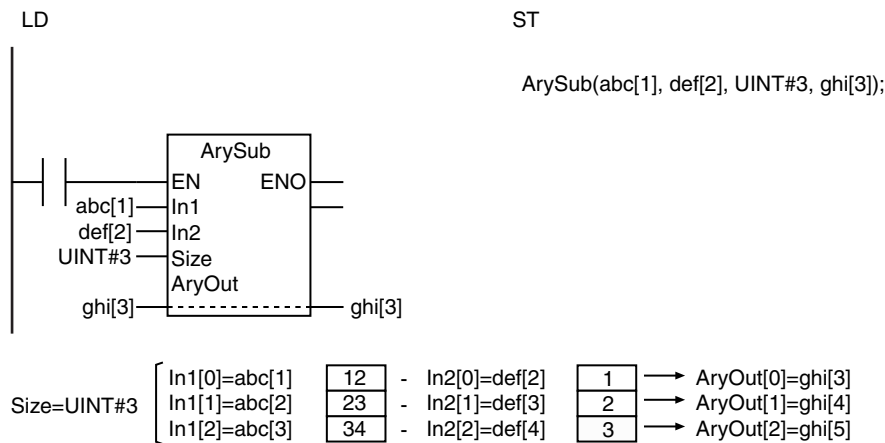

Precautions for Correct Use

- Use the same data type for *In1[]*, *In2[]*, and *AryOut[]*. If they are different, a building error will occur.
- If the subtraction results exceed the valid range of *AryOut[]*, the elements of *AryOut[]* will contain illegal values. An error will not occur. Corruption will not occur in the data in the memory area adjacent to those elements.
- The values in *AryOut[]* do not change if the value of *Size* is 0.
- Return value *Out* is not used when the instruction is used in ST.
- An error occurs in the following cases. *ENO* will be FALSE, and *AryOut[]* will not change.
 - The value of *Size* exceeds the array range of *In1[]*, *In2[]*, or *AryOut[]*.

ArySubV

The ArySubV instruction subtracts the same value from specified elements of an array.

Instruction	Name	FB/FUN	Graphic expression	ST expression
ArySubV	Array Value Subtraction	FUN		ArySubV(In1, In2, Size, AryOut);

Variables

Name	Meaning	I/O	Description	Valid range	Unit	Default
In1[] (array)	Minuend array	Input	Minuend array	Depends on data type.	---	*
In2	Subtrahend		Subtrahend			
Size	Number of elements		Number of elements of <i>In1[]</i> for subtraction			1
AryOut[] (array)	Subtraction results array	In-out	Subtraction results array	Depends on data type.	---	---
Out	Return value	Output	Always TRUE	TRUE only	---	---

* If you omit the input parameter, the default value is not applied. A building error will occur.

	Boolean	Bit strings				Integers							Real numbers	Times, durations, dates, and text strings						
	BOOL	BYTE	WORD	DWORD	LWORD	USINT	UINT	UDINT	ULINT	SINT	INT	DINT	LINT	REAL	LREAL	TIME	DATE	TOD	DT	STRING
In1[] (array)						OK	OK	OK	OK	OK	OK	OK	OK	OK						
In2	Must be same data type as the elements of <i>In1[]</i> .																			
Size							OK													
AryOut[] (array)	Must be same data type as <i>In1[]</i> .																			
Out	OK																			

Function

The ArySubV instruction subtracts subtrahend *In2* from *Size* elements of minuend array *In1[]* starting from *In1[0]*. It outputs the results to subtraction results array *AryOut[]*.

The following example is for when *In2* is INT#11 and *Size* is UINT#3.

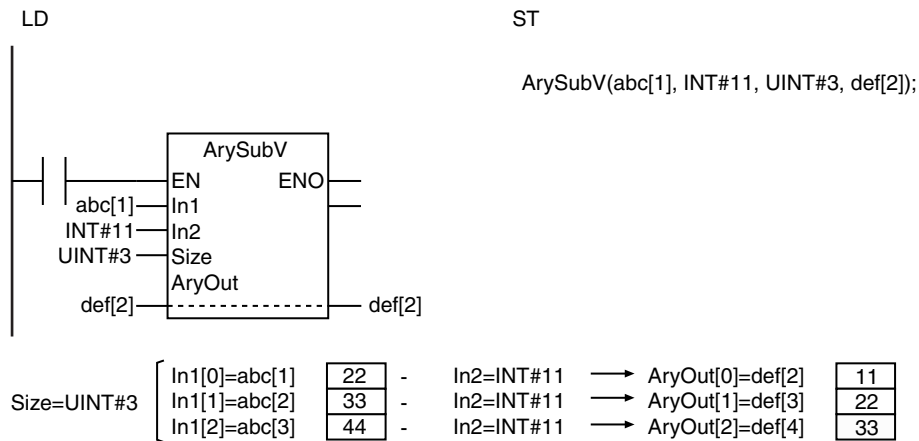

Precautions for Correct Use

- Use the same data type for *In1[]*, *In2*, and *AryOut[]*. If they are different, a building error will occur.
- If the subtraction results exceed the valid range of *AryOut[]*, the elements of *AryOut[]* will contain illegal values. An error will not occur. Corruption will not occur in the data in the memory area adjacent to those elements.
- The values in *AryOut[]* do not change if the value of *Size* is 0.
- Return value *Out* is not used when the instruction is used in ST.
- An error occurs in the following cases. *ENO* will be FALSE, and *AryOut[]* will not change.
 - The value of *Size* exceeds the array area of *In1[]* or *AryOut[]*.

AryMean

The AryMean instruction calculates the average of the elements of an array.

Instruction	Name	FB/FUN	Graphic expression	ST expression
AryMean	Array Mean	FUN		Out := AryMean(In, Size);

Variables

Name	Meaning	I/O	Description	Valid range	Unit	Default
In[] (array)	Array to process	Input	Array to process	Depends on data type.	---	*
Size	Number of elements to process		Number of <i>In[]</i> elements			1
Out	Calculation result	Output	Calculation result	Depends on data type.	---	---

* If you omit the input parameter, the default value is not applied. A building error will occur.

	Boolean	Bit strings				Integers							Real numbers		Times, durations, dates, and text strings						
	BOOL	BYTE	WORD	DWORD	LWORD	USINT	UINT	UDINT	ULINT	SINT	INT	DINT	LINT	REAL	LREAL	TIME	DATE	TOD	DT	STRING	
In[] (array)						OK	OK	OK	OK	OK	OK	OK	OK	OK	OK	OK					
Size							OK														
Out						OK	OK	OK	OK	OK	OK	OK	OK	OK	OK	OK					

Function

The AryMean instruction calculates the average of *Size* elements of array to process *In[]* starting from *In[0]*.

The following example is for when *Size* is UINT#5.

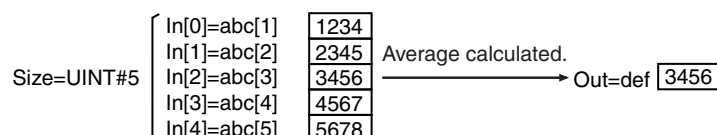
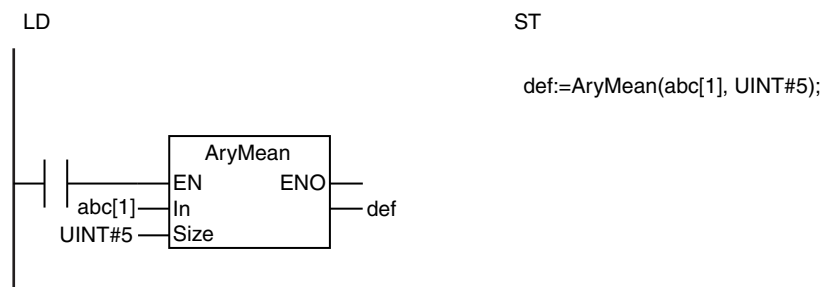

Precautions for Correct Use

- Refer to the descriptions of the functions of the ADD (+) instruction (page 2-166), SUB (-) instruction (page 2-174), MUL (*) instruction (page 2-181), and DIV (/) instruction (page 2-189) for the calculation results when the value of *In[]* is positive infinity, negative infinity, or nonnumeric data.
- If *In[]* or *Out* is an integer, the decimal portion of the average is truncated.
- If you use a different data type for *In[]* and *Out*, make sure the valid range of *Out* includes the valid range of *In[]*.
- If the calculation result exceeds the valid range of *Out*, *Out* will contain an illegal value. An error will not occur.
- If an intermediate value in the calculation process exceeds the valid range of *IN[]*, *Out* will contain an illegal value. An error will not occur.
- If the value of *Size* is 0, the value of *Out* is 0.
- An error occurs in the following case. *ENO* will be FALSE, and *Out* will not change.
 - The value of *Size* exceeds the array area of *In[]*.

ArySD

The ArySD instruction calculates standard deviation of the elements of an array.

Instruction	Name	FB/FUN	Graphic expression	ST expression
ArySD	Array Element Standard Deviation	FUN		Out:=ArySD(In, Size);

Variables

Name	Meaning	I/O	Description	Valid range	Unit	Default
In[] (array)	Array to process	Input	Array to process	Depends on data type.	---	*
Size	Number of elements		Number of elements of In[] for conversion			2
Out	Standard deviation	Output	Standard deviation	Depends on data type.	---	---

* If you omit an input parameter, the default value is not applied. A building error will occur.

	Boolean	Bit strings				Integers							Real numbers	Times, durations, dates, and text strings						
	BOOL	BYTE	WORD	DWORD	LWORD	USINT	UINT	UDINT	ULINT	SINT	INT	DINT	LINT	REAL	LREAL	TIME	DATE	TOD	DT	STRING
In[] (array)														OK	OK					
Size							OK													
Out														OK	OK					

Function

The ArySD instruction calculates the standard deviation of Size elements of array to process In[] starting from In[0].

$$\text{Standard deviation} = \sqrt{\frac{\sum_i (\text{In}[i] - \text{InM})^2}{\text{Size} - 1}}$$

i: Subscript of In[], 0 to Size - 1
 InM: Average value of In[0] to In[Size - 1]

The following example is for when *Size* is UINT#5.

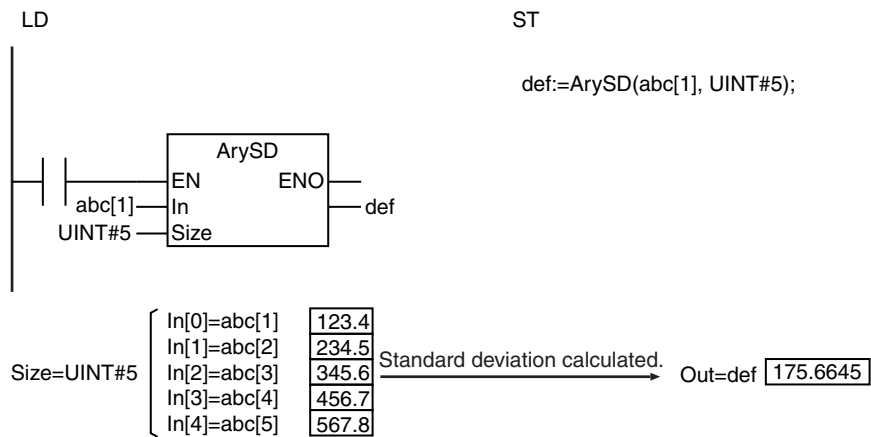

Precautions for Correct Use

- If the value of *Size* is 0 or 1, the value of *Out* is 0.
- If an intermediate value in the calculation process exceeds the valid range of *IN[]*, *Out* will contain an illegal value. An error will not occur.
- An error occurs in the following case. *ENO* will be FALSE, and *Out* will not change.
 - The value of *Size* exceeds the array area of *In[]*.

ModReal

The ModReal instruction calculates the remainder of real number division.

Instruction	Name	FB/FUN	Graphic expression	ST expression
ModReal	Real Number Modulo-division	FUN		Out:=ModReal(In1, In2);

Variables

Name	Meaning	I/O	Description	Valid range	Unit	Default
In1	Dividend	Input	Dividend	Depends on data type.	---	*
In2	Divisor		Divisor			
Out	Remainder	Output	Remainder	Depends on data type.	---	---

* If you omit an input parameter, the default value is not applied. A building error will occur.

	Boolean	Bit strings					Integers							Real numbers		Times, durations, dates, and text strings				
	BOOL	BYTE	WORD	DWORD	LWORD	USINT	UINT	UDINT	ULINT	SINT	INT	DINT	LINT	REAL	LREAL	TIME	DATE	TOD	DT	STRING
In1														OK	OK					
In2														OK	OK					
Out														OK	OK					

Function

The ModReal instruction divides dividend *In1* by divisor *In2* to find the remainder.

The following example is for when *In1* is REAL#-9.9 and *In2* is REAL#-3.14. The value of variable *abc* will be REAL#-0.48.

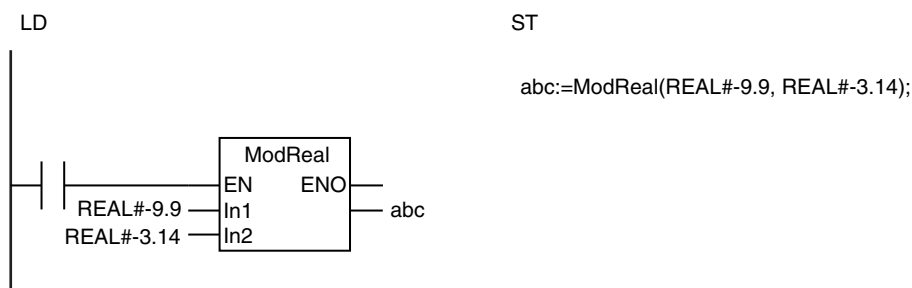

The ModReal instruction divides *In1* by *In2* to find the remainder.
The remainder of $-9.9/(-3.14)$ is -0.48 , so the value of *abc* will be REAL#-0.48.



Additional Information

Use the CheckReal instruction (page 2-237) to see if the value of *Out* is positive infinity, negative infinity, or nonnumeric data.

Precautions for Correct Use

- The following table shows the values of *Out* for different combinations of *In1* and *In2* values.

		<i>In1</i>				
		0	Number	$+\infty$	$-\infty$	Nonnumeric data
<i>In2</i>	0	Nonnumeric data	Nonnumeric data	Nonnumeric data	Nonnumeric data	Nonnumeric data
	Number	0	Remainder of <i>In1/In2</i>	Nonnumeric data	Nonnumeric data	Nonnumeric data
	$+\infty$	0	Value of <i>In1</i>	Nonnumeric data	Nonnumeric data	Nonnumeric data
	$-\infty$	0	Value of <i>In1</i>	Nonnumeric data	Nonnumeric data	Nonnumeric data
	Nonnumeric data	Nonnumeric data	Nonnumeric data	Nonnumeric data	Nonnumeric data	Nonnumeric data

- If you pass an integer parameter to *In1* or *In2*, the data type is converted as follows:

Data type of parameter that is passed to <i>In1</i> or <i>In2</i>	Data type of <i>In1</i> or <i>In2</i>
USINT, UINT, SINT, or INT	REAL
UDINT or DINT	LREAL
ULINT or LINT	A building error will occur.

Fraction

The Fraction instruction finds the fractional part of a real number.

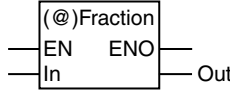
Instruction	Name	FB/FUN	Graphic expression	ST expression
Fraction	Real Number Fraction	FUN		Out:=Fraction(In);

Variables

Name	Meaning	I/O	Description	Valid range	Unit	Default
In	Real number	Input	Real number	Depends on data type.	---	*
Out	Fractional part	Output	Fractional part	Depends on data type.	---	---

* If you omit an input parameter, the default value is not applied. A building error will occur.

	Boolean	Bit strings				Integers								Real numbers		Times, durations, dates, and text strings					
		BOOL	BYTE	WORD	DWORD	LWORD	USINT	UINT	UDINT	ULINT	SINT	INT	DINT	LINT	REAL	LREAL	TIME	DATE	TOD	DT	STRING
In														OK	OK						
Out														OK	OK						

Function

The Fraction instruction finds the fractional part of real number *In*.

The following example is for when *In* is REAL#-123.456. The value of variable *abc* will be REAL#-0.456.

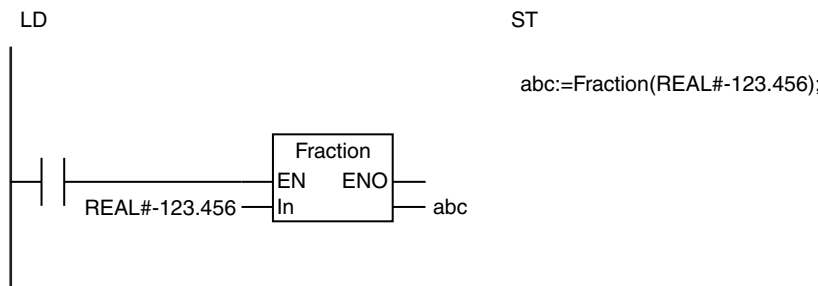

The Fraction instruction finds the fractional part of *In*.
The fractional part of -123.456 is -0.456, so the value of *abc* will be REAL#0.456.

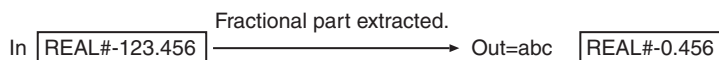

Additional Information

- Use the CheckReal instruction (page 2-237) to see if the value of *Out* is positive infinity, negative infinity, or nonnumeric data.
- If you pass an integer parameter to *In*, the data type is converted as follows:

Data type of parameter that is passed to <i>In</i>	Data type of <i>In</i>
USINT, UINT, SINT, or INT	REAL
UDINT or DINT	LREAL
ULINT or LINT	A building error will occur.

CheckReal

The CheckReal instruction checks a real number to see if it is infinity or nonnumeric data.

Instruction	Name	FB/FUN	Graphic expression	ST expression
CheckReal	Real Number Check	FUN	<pre> graph LR subgraph CheckReal EN --- In ENO --- Out Nan PosInfinite NegInfinite end </pre>	CheckReal(In, Nan, PosInfinite, NegInfinite);

Variables

Name	Meaning	I/O	Description	Valid range	Unit	Default
In	Real number	Input	Real number	Depends on data type.	---	*
Out	Return value	Output	Always TRUE	TRUE only	---	---
Nan	Nonnumeric data check result		TRUE: Nonnumeric data FALSE: Not nonnumeric data	Depends on data type.		
PosInfinite	Positive infinity check result		TRUE: Positive infinity FALSE: Not positive infinity			
NegInfinite	Negative infinity check result		TRUE: Negative infinity FALSE: Not negative infinity			

* If you omit an input parameter, the default value is not applied. A building error will occur.

	Boolean	Bit strings				Integers							Real numbers		Times, durations, dates, and text strings					
	BOOL	BYTE	WORD	DWORD	LWORD	USINT	UINT	UDINT	ULINT	SINT	INT	DINT	LINT	REAL	LREAL	TIME	DATE	TOD	DT	STRING
In														OK	OK					
Out	OK																			
Nan	OK																			
PosInfinite	OK																			
NegInfinite	OK																			

Function

The CheckReal instruction checks a real number In to see if it is nonnumeric data, positive infinity, or negative infinity. It outputs the results to *Nan*, *PosInfinite*, and *NegInfinite*.

The following figure shows a programming example. The values of REAL variables *a* and *b* are multiplied and the result is tested to see if it is a real number. If the multiplication result is a real number, it is assigned to variable *d*.

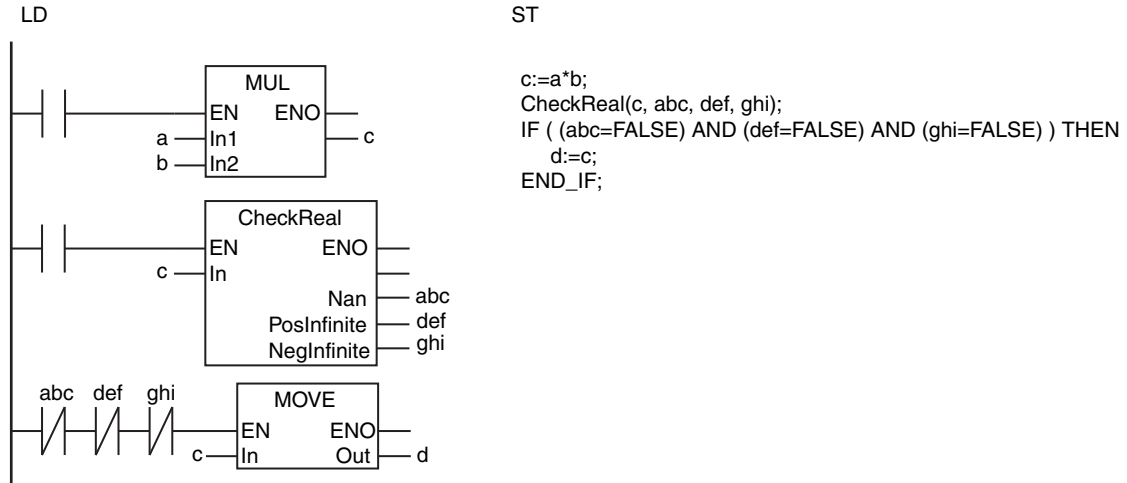

If the product *c* of *a* and *b* is not nonnumeric data, positive infinity, or negative infinity, then the value of *c* is assigned to *d*.

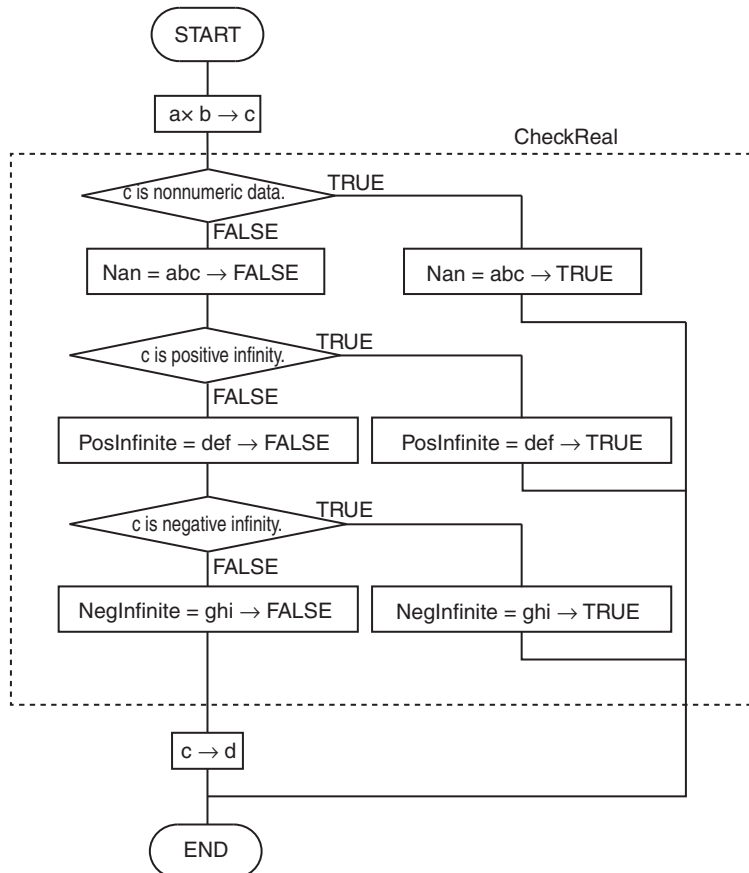

Additional Information

Use this instruction on the result of a math instruction that handles real numbers to see if the result is nonnumeric data, positive infinity, or negative infinity.

Precautions for Correct Use

- Return value *Out* is not used when the instruction is used in ST.
- If you pass an integer parameter to *In*, the data type is converted as follows:

Data type of parameter that is passed to <i>In</i>	Data type of <i>In</i>
USINT, UINT, SINT, or INT	REAL
UDINT or DINT	LREAL
ULINT or LINT	A building error will occur.

BCD Conversion Instructions

Instruction	Name	Page
_BCD_TO_*	BCD-to-Unsigned Integer Conversion Group	2-242
_TO_BCD_*	Unsigned Integer-to-BCD Conversion Group	2-245
BCD_TO_**	BCD Data Type-to-Unsigned Integer Conversion Group	2-247
BCDsToBin	Signed BCD-to-Signed Integer Conversion	2-250
BinToBCDs_**	Signed Integer-to-BCD Conversion Group	2-253
AryToBCD	Array BCD Conversion	2-256
AryToBin	Array Unsigned Integer Conversion	2-258

** _BCD_TO_ ***

These instructions convert BCD bit strings into unsigned integers.

Instruction	Name	FB/FUN	Graphic expression	ST expression
_BCD_TO_*	BCD-to-Unsigned Integer Conversion Group	FUN	<p>*** must be a bit string data type. **** must be an integer data type.</p>	Out:=**_BCD_TO_*** (In); *** must be a bit string data type. **** must be an integer data type.

Variables

Name	Meaning	I/O	Description	Valid range	Unit	Default
In	Data to convert	Input	Data to convert	*	---	0
Out	Conversion result	Output	Conversion result	*	---	---

* The valid ranges depend on the data types of *In* and *Out*. Refer to *Function*, below, for details.

	Boolean	Bit strings					Integers							Real numbers		Times, durations, dates, and text strings					
		BOOL	BYTE	WORD	DWORD	LWORD	USINT	UINT	UDINT	ULINT	SINT	INT	DINT	LINT	REAL	LREAL	TIME	DATE	TOD	DT	STRING
In		OK	OK	OK	OK																
Out						OK	OK	OK	OK	OK	OK	OK	OK								

Function

These instructions convert data to convert *In* (which must be a BCD bit string) into an unsigned integer. The name of the instruction is determined by the data types of *In* and conversion result *Out*. For example, if *In* is WORD data and *Out* is UINT data, the name of the instruction is WORD_BCD_TO_UINT. The following example for the WORD_BCD_TO_UINT instruction is for when *In* is WORD16#3452.

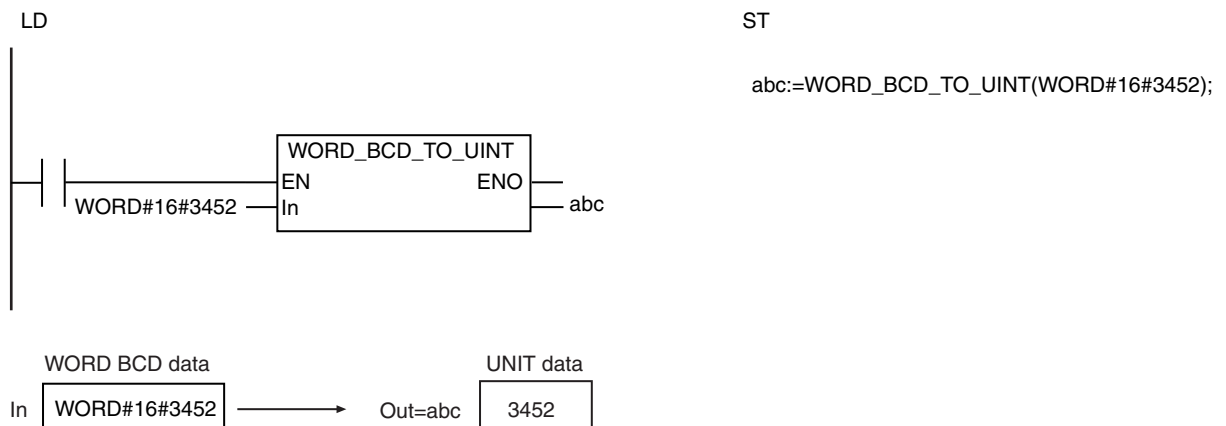

The following table shows the valid ranges for *In* and *Out* according to their data types.

Data type of <i>In</i>	Data type of <i>Out</i>	Valid range for <i>In</i>	Valid range for <i>Out</i>
BYTE	USINT	16#00 to 16#99 (BCD)	0 to 99
	UINT		
	UDINT		
	ULINT		
	SINT		
	INT		
	DINT		
	LINT		
WORD	USINT	16#0000 to 16#0255 (BCD)	0 to 255
	UINT	16#0000 to 16#9999 (BCD)	0 to 9999
	UDINT		
	ULINT	16#0000 to 16#0127 (BCD)	0 to 127
	SINT		
	INT		
	DINT		
	LINT		
DWORD	USINT	16#0000_0000 to 16#0000_0255 (BCD)	0 to 255
	UINT	16#0000_0000 to 16#0006_5535 (BCD)	0 to 65535
	UDINT	16#0000_0000 to 16#9999_9999 (BCD)	0 to 99999999
	ULINT		
	SINT	16#0000_0000 to 16#0000_0127 (BCD)	0 to 127
	INT	16#0000_0000 to 16#0003_2767 (BCD)	0 to 32767
	DINT	16#0000_0000 to 16#9999_9999 (BCD)	0 to 99999999
	LINT		
LWORD	USINT	16#0000_0000_0000_0000 to 16#0000_0000_0000_0255 (BCD)	0 to 255
	UINT	16#0000_0000_0000_0000 to 16#0000_0000_0006_5535 (BCD)	0 to 65535
	UDINT	16#0000_0000_0000_0000 to 16#0000_0042_9496_7295 (BCD)	0 to 4294967295
	ULINT	16#0000_0000_0000_0000 to 16#9999_9999_9999_9999 (BCD)	0 to 9999999999999999
	SINT	16#0000_0000_0000_0000 to 16#0000_0000_0000_0127 (BCD)	0 to 127
	INT	16#0000_0000_0000_0000 to 16#0000_0000_0003_2767 (BCD)	0 to 32767
	DINT	16#0000_0000_0000_0000 to 16#0000_0021_4748_3647 (BCD)	0 to 2147483647
	LINT	16#0000_0000_0000_0000 to 16#9999_9999_9999_9999 (BCD)	0 to 9999999999999999

Additional Information

- To convert a BCD bit string to an integer, use a `BCD_TO_**` instruction (page 2-247).
- To convert an integer to a BCD bit string, use a `**_TO_BCD_***` instruction (page 2-245).

Precautions for Correct Use

- Always use the correct instruction name for the data types of *In* and *Out*.
- If the data size of *Out* is larger than the data size of *In*, the upper digits of *Out* will contain 0.
- An error occurs in the following cases. *ENO* will be FALSE, and *Out* will not change.

- The value of *In* is outside of the valid range.
- The value in *In* is not BCD bit string data (i.e., contains A, B, C, D, E, or F hexadecimal).

_TO_BCD_

These instructions convert unsigned integers to BCD bit strings.

Instruction	Name	FB/FUN	Graphic expression	ST expression
_TO_BCD_	Unsigned Integer-to-BCD Conversion Group	FUN	<p>*** must be an integer data type. **** must be a bit string data type.</p>	Out:=**_TO_BCD_** (In); *** must be an integer data type. **** must be a bit string data type.

Variables

Name	Meaning	I/O	Description	Valid range	Unit	Default
In	Data to convert	Input	Data to convert	*	---	0
Out	Conversion result	Output	Conversion result	*	---	---

* The valid ranges depend on the data types of *In* and *Out*. Refer to *Function*, below, for details.

	Boolean	Bit strings				Integers							Real numbers		Times, durations, dates, and text strings						
		BOOL	BYTE	WORD	DWORD	LWORD	USINT	UINT	UDINT	ULINT	SINT	INT	DINT	LINT	REAL	LREAL	TIME	DATE	TOD	DT	STRING
In						OK	OK	OK	OK	OK	OK	OK	OK								
Out		OK	OK	OK	OK																

Function

These instructions convert data to convert *In* (which must be an unsigned integer) to a BCD bit string. The name of the instruction is determined by the data types of *In* and conversion result *Out*. For example, if *In* is *UINT* data and *Out* is *WORD* data, the name of the instruction is *UINT_TO_BCD_WORD*. The following example for the *UINT_TO_BCD_WORD* instruction is for when *In* is *UNIT#3452*.

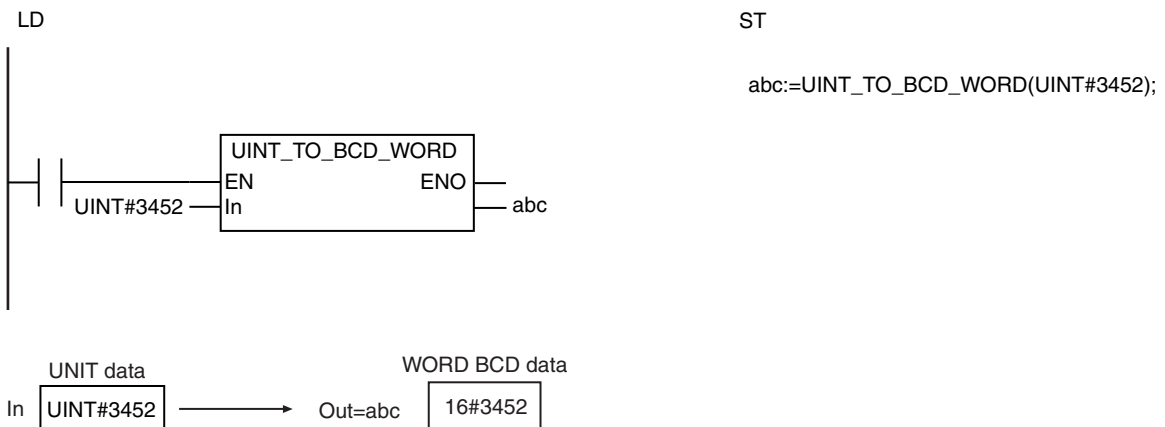

The following table shows the valid ranges for *In* and *Out* according to their data types.

Data type of <i>In</i>	Data type of <i>Out</i>	Valid range for <i>In</i>	Valid range for <i>Out</i>	
USINT	BYTE	0 to 99	16#00 to 16#99 (BCD)	
	WORD	0 to 255	16#0000 to 16#0255 (BCD)	
	DWORD		16#0000_0000 to 16#000_0255 (BCD)	
	LWORD		16#0000_0000_0000_0000 to 16#0000_0000_0000_0255 (BCD)	
UINT	BYTE		0 to 99	16#00 to 16#99 (BCD)
UINT	WORD	0 to 9999	16#0000 to 16#9999 (BCD)	
	DWORD	0 to 65535	16#0000_0000 to 16#0006_5535 (BCD)	
	LWORD		16#0000_0000_0000_0000 to 16#0000_0000_0006_5535 (BCD)	
	UDINT		BYTE	0 to 99
UDINT	WORD		0 to 9999	16#0000 to 16#9999 (BCD)
	DWORD	0 to 99999999	16#0000_0000 to 16#9999_9999 (BCD)	
	LWORD	0 to 4294967295	16#0000_0000_0000_0000 to 16#0000_0042_9496_7295 (BCD)	
	ULINT	BYTE	0 to 99	16#00 to 16#99 (BCD)
ULINT	WORD	0 to 9999	16#0000 to 16#9999 (BCD)	
	DWORD	0 to 99999999	16#0000_0000 to 16#9999_9999 (BCD)	
	LWORD	0 to 9999999999999999	16#0000_0000_0000_0000 to 16#9999_9999_9999_9999 (BCD)	
	SINT	BYTE	0 to 99	16#00 to 16#99 (BCD)
SINT	WORD	0 to 127	16#0000 to 16#0127 (BCD)	
	DWORD		16#0000_0000 to 16#0000_0127 (BCD)	
	LWORD		16#0000_0000_0000_0000 to 16#0000_0000_0000_0127 (BCD)	
	INT		BYTE	0 to 99
INT	WORD	0 to 9999	16#0000 to 16#9999 (BCD)	
	DWORD	0 to 32767	16#0000_0000 to 16#0003_2767 (BCD)	
	LWORD		16#0000_0000_0000_0000 to 16#0000_0000_0003_2767 (BCD)	
	DINT		BYTE	0 to 99
DINT	WORD		0 to 9999	16#0000 to 16#9999 (BCD)
	DWORD	0 to 99999999	16#0000_0000 to 16#9999_9999 (BCD)	
	LWORD	0 to 2147483647	16#0000_0000_0000_0000 to 16#0000_0021_4748_3647 (BCD)	
	LINT	BYTE	0 to 99	16#00 to 16#99 (BCD)
LINT	WORD	0 to 9999	16#0000 to 16#9999 (BCD)	
	DWORD	0 to 99999999	16#0000_0000 to 16#9999_9999 (BCD)	
	LWORD	0 to 9999999999999999	16#0000_0000_0000_0000 to 16#9999_9999_9999_9999 (BCD)	

Additional Information

- To convert a specific BCD bit string to an integer, use a `**_BCD_TO_***` instruction (page 2-242).
- To convert a BCD bit string to an integer, use a `BCD_TO_**` instruction (page 2-247).

Precautions for Correct Use

- Always use the correct instruction name for the data types of *In* and *Out*.
- If the data size of *Out* is larger than the data size of *In*, the upper digits of *Out* will contain 0.
- An error occurs in the following case. *ENO* will be FALSE, and *Out* will not change.
 - The value of *In* is outside of the valid range.

BCD_TO_**

The BCD_TO_** instruction converts BCD bit strings into unsigned integers.

Instruction	Name	FB/FUN	Graphic expression	ST expression
BCD_TO_**	BCD Data Type-to-Unsigned Integer Conversion Group	FUN		Out:=BCD_TO_** (In); "***" must be an integer data type.

Variables

Name	Meaning	I/O	Description	Valid range	Unit	Default
In	Data to convert	Input	Data to convert	*1	---	*2
Out	Conversion result	Output	Conversion result	*1	---	---

*1 The valid ranges depend on the data types of *In* and *Out*. Refer to *Function*, below, for details.

*2 If you omit the input parameter, the default value is not applied. A building error will occur.

	Boolean	Bit strings					Integers							Real numbers		Times, durations, dates, and text strings				
	BOOL	BYTE	WORD	DWORD	LWORD	USINT	UINT	UDINT	ULINT	SINT	INT	DINT	LINT	REAL	LREAL	TIME	DATE	TOD	DT	STRING
In		OK	OK	OK	OK															
Out						OK	OK	OK	OK	OK	OK	OK								

Function

These instructions convert data to convert *In* (which must be a BCD bit string) into an unsigned integer. The name of the instruction is determined by the data type of conversion result *Out*. For example, if *Out* is the `UINT` data type, the instruction is `BCD_TO_UINT`.

The following example for the `BCD_TO_UINT` instruction is for when *In* is `WORD#16#3452`.

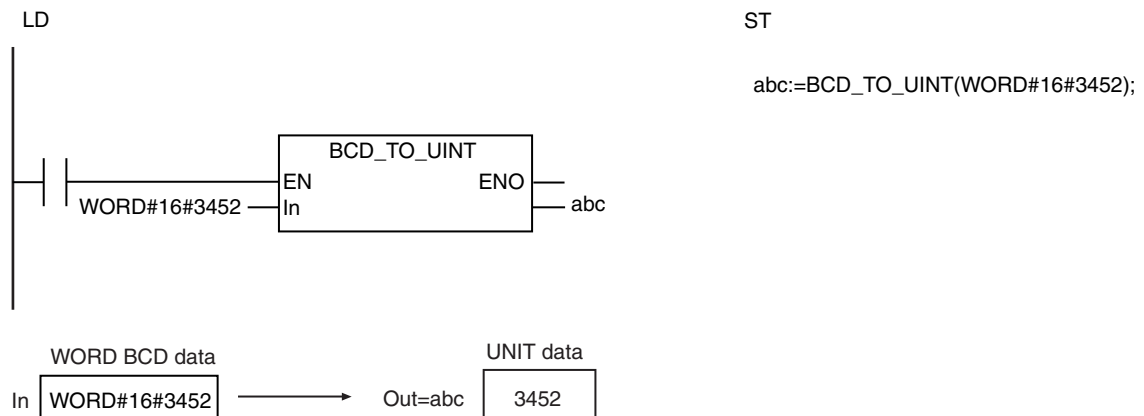

The following table shows the valid ranges for *In* and *Out* according to their data types.

Data type of <i>In</i>	Data type of <i>Out</i>	Valid range for <i>In</i>	Valid range for <i>Out</i>
BYTE	USINT	16#00 to 16#99 (BCD)	0 to 99
	UINT		
	UDINT		
	ULINT		
	SINT		
	INT		
	DINT		
	LINT		
WORD	USINT	16#0000 to 16#0255 (BCD)	0 to 255
	UINT	16#0000 to 16#9999 (BCD)	0 to 9999
	UDINT		
	ULINT	16#0000 to 16#0127 (BCD)	0 to 127
	SINT		
	INT	16#0000 to 16#9999 (BCD)	0 to 9999
	DINT		
	LINT		
DWORD	USINT	16#0000_0000 to 16#0000_0255 (BCD)	0 to 255
	UINT	16#0000_0000 to 16#0006_5535 (BCD)	0 to 65535
	UDINT	16#0000_0000 to 16#9999_9999 (BCD)	0 to 99999999
	ULINT		
	SINT	16#0000_0000 to 16#0000_0127 (BCD)	0 to 127
	INT	16#0000_0000 to 16#0003_2767 (BCD)	0 to 32767
	DINT	16#0000_0000 to 16#9999_9999 (BCD)	0 to 99999999
	LINT		
LWORD	USINT	16#0000_0000_0000_0000 to 16#0000_0000_0000_0255 (BCD)	0 to 255
	UINT	16#0000_0000_0000_0000 to 16#0000_0000_0006_5535 (BCD)	0 to 65535
	UDINT	16#0000_0000_0000_0000 to 16#0000_0042_9496_7295 (BCD)	0 to 4294967295
	ULINT	16#0000_0000_0000_0000 to 16#9999_9999_9999_9999 (BCD)	0 to 9999999999999999
	SINT	16#0000_0000_0000_0000 to 16#0000_0000_0000_0127 (BCD)	0 to 127
	INT	16#0000_0000_0000_0000 to 16#0000_0000_0003_2767 (BCD)	0 to 32767
	DINT	16#0000_0000_0000_0000 to 16#0000_0021_4748_3647 (BCD)	0 to 2147483647
	LINT	16#0000_0000_0000_0000 to 16#9999_9999_9999_9999 (BCD)	0 to 9999999999999999

Additional Information

- To convert a specific BCD bit string to an integer, use a ****_BCD_TO_***** instruction (page 2-242).
- To convert an integer to a BCD bit string, use a ****_TO_BCD_***** instruction (page 2-245).

Precautions for Correct Use

- Always use the correct instruction name for the data type of *Out*.
- If the data size of *Out* is larger than the data size of *In*, the upper digits of *Out* will contain 0.
- An error occurs in the following cases. *ENO* will be FALSE, and *Out* will not change.
 - The value of *In* is outside of the valid range.
 - The value in *In* is not BCD bit string data (i.e., contains A, B, C, D, E, or F hexadecimal).

BCDsToBin

The BCDsToBin instruction converts signed BCD bit strings to signed integers.

Instruction	Name	FB/FUN	Graphic expression	ST expression
BCDsToBin	Signed BCD-to-Signed Integer Conversion	FUN	<pre> graph LR EN[EN] --- BCDsToBin[(@)BCDsToBin] In[In] --- BCDsToBin Format[Format] --- BCDsToBin BCDsToBin --- Out[Out] </pre>	Out:=BCDsToBin(In, Format);

Variables

Name	Meaning	I/O	Description	Valid range	Unit	Default
In	Data to convert	Input	Data to convert	*1	---	*2
Format	Data format number		Format of BCD bit string	_BCD0 to _BCD3		_BCD0
Out	Conversion result	Output	Conversion result	*1	---	---

*1 The valid range depends on the value of *Format*. Refer to *Function*, below, for details.

*2 If you omit the input parameter, the default value is not applied. A building error will occur.

	Boolean	Bit strings					Integers							Real numbers		Times, durations, dates, and text strings				
	BOOL	BYTE	WORD	DWORD	LWORD	USINT	UINT	UDINT	ULINT	SINT	INT	DINT	LINT	REAL	LREAL	TIME	DATE	TOD	DT	STRING
In		OK	OK	OK	OK															
Format	Refer to <i>Function</i> for the enumerators of the enumerated type <code>_eBCD_FORMAT</code> .																			
Out	Must be a signed integer data type that is the same size as <i>In</i> .																			

Function

The BCDsToBin instruction converts signed BCD bit string *In* to a signed integer.

The data type of data format number *Format* is enumerated type `_eBCD_FORMAT`. Select one of the following: `_BCD0`, `_BCD1`, `_BCD2`, or `_BCD3`. The sign specification in the upper four bits of *In* depends on the BCD format number. The data format examples shown below use WORD data for *In*.

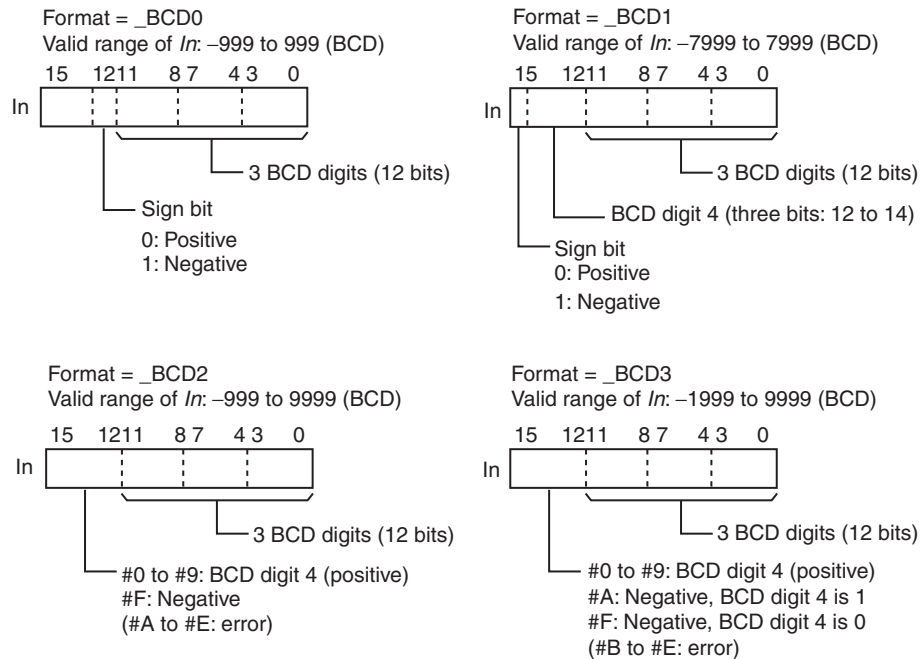

The same sizes of data types are used for *In* and *Out*. The valid ranges depend on the value of *Format*, as shown below.

		Value of <i>Format</i>			
		<code>_BCD0</code>	<code>_BCD1</code>	<code>_BCD2</code>	<code>_BCD3</code>
Data type of <i>In</i> ↓ Data type of <i>Out</i>	BYTE ↓ SINT	-9 to 9	-79 to 79	-9 to 99	-19 to 99
	WORD ↓ INT	-999 to 999	-7999 to 7999	-999 to 9999	-1999 to 9999
	DWORD ↓ DINT	-9999999 to 9999999	-79999999 to 79999999	-9999999 to 99999999	-19999999 to 99999999
	LWORD ↓ LINT	-9999999999999999 to 9999999999999999	-7999999999999999 to 7999999999999999	-9999999999999999 to 9999999999999999	-1999999999999999 to 9999999999999999

The following example is for when *In* is `WORD#2#1011_0100_0101_0010` and *Format* is `_BCD1`.

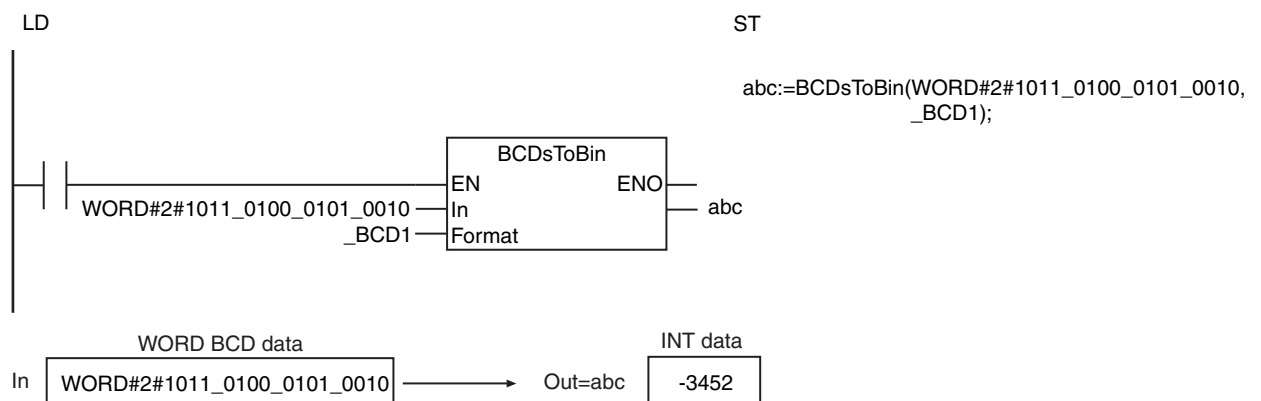

Precautions for Correct Use

- Use the same sizes of data types for *In* and *Out*.
- An error occurs in the following cases. *ENO* will be FALSE, and *Out* will not change.
 - The value of *Format* is *_BCD0* and the upper digit of *In* is 2 to F.
 - The value of *Format* is *_BCD2* and the upper digit of *In* is A to E.
 - The value of *Format* is *_BCD3* and the upper digit of *In* is B to E.
 - Except for the above conditions, any digit in *In* is A to F.
 - The value of *Format* is outside of the valid range.

BinToBCDs_**

These instructions convert signed integers to signed BCD bit strings.

Instruction	Name	FB/FUN	Graphic expression	ST expression
BinToBCDs_**	Signed Integer-to-BCD Conversion Group	FUN		Out:=BinToBCDs(In, Format); "***" must be a bit string data type.

Variables

Name	Meaning	I/O	Description	Valid range	Unit	Default
In	Data to convert	Input	Data to convert	*	---	0
Format	Data format number		Format of BCD bit string	_BCD0 to _BCD3		_BCD0
Out	Conversion result	Output	Conversion result	*	---	---

* The valid range depends on the value of *Format*. Refer to *Function*, below, for details.

	Boolean	Bit strings					Integers							Real numbers	Times, durations, dates, and text strings					
	BOOL	BYTE	WORD	DWORD	LWORD	USINT	UINT	UDINT	ULINT	SINT	INT	DINT	LINT	REAL	LREAL	TIME	DATE	TOD	DT	STRING
In										OK	OK	OK	OK							
Format	Refer to <i>Function</i> for the enumerators of the enumerated type <code>_eBCD_FORMAT</code> .																			
Out	Must be same size of data type as <i>In</i>																			

Function

These instructions convert signed integer *In* to a signed BCD bit string.

The name of the instruction is determined by the data type of *Out*. For example, if *Out* is the `WORD` data type, the instruction is `BinToBCDs_WORD`.

The data type of data format number *Format* is enumerated type *_eBCD_FORMAT*. Select one of the following: *_BCD0*, *_BCD1*, *_BCD2*, or *_BCD3*. The sign specification in the upper four bits of *Out* depends on the BCD format number. The data format examples shown below use *WORD* data for *Out*.

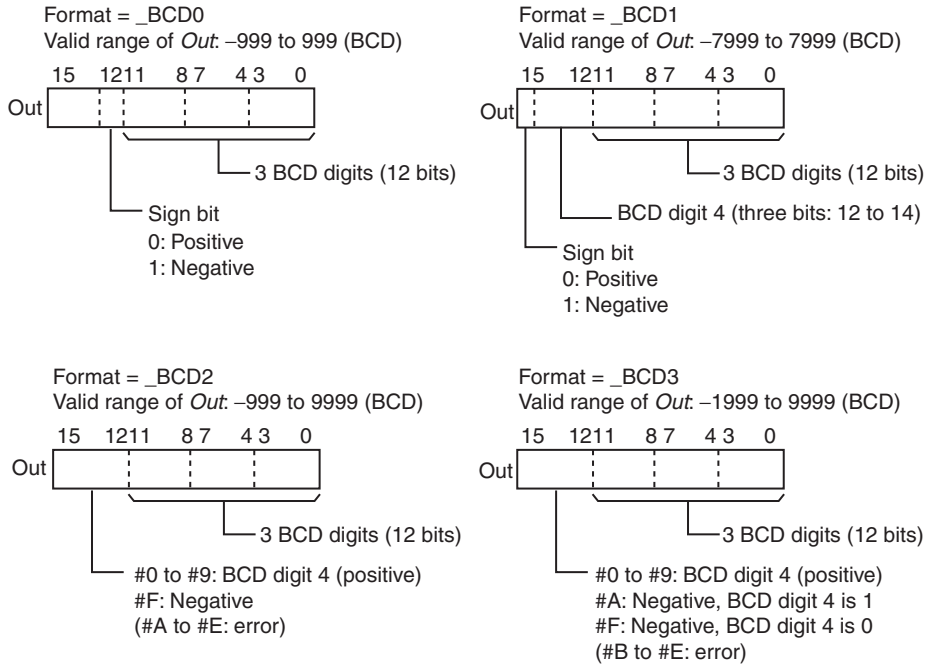

The same sizes of data types are used for *In* and *Out*. The valid ranges depend on the value of *Format*, as shown below.

		Value of <i>Format</i>			
		<i>_BCD0</i>	<i>_BCD1</i>	<i>_BCD2</i>	<i>_BCD3</i>
Data type of <i>In</i> ↓ Data type of <i>Out</i>	SINT ↓ BYTE	-9 to 9	-79 to 79	-9 to 99	-19 to 99
	INT ↓ WORD	-999 to 999	-7999 to 7999	-999 to 9999	-1999 to 9999
	DINT ↓ DWORD	-9999999 to 9999999	-79999999 to 79999999	-9999999 to 99999999	-19999999 to 99999999
	LINT ↓ LWORD	-9999999999999999 to 9999999999999999	-7999999999999999 to 7999999999999999	-9999999999999999 to 9999999999999999	-1999999999999999 to 9999999999999999

The following example shows the *BinToBCDs_WORD* instruction when *In* is *INT#-3452* and *Format* is *_BCD1*.

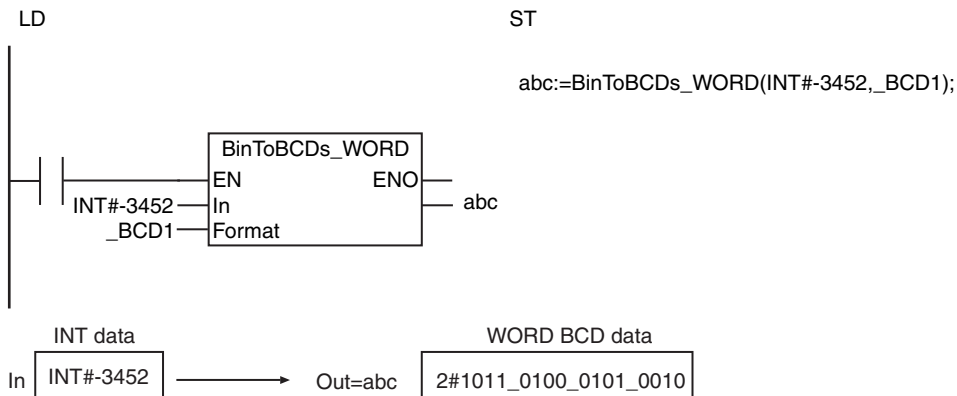

Precautions for Correct Use

- Always use the correct instruction name for the data type of *Out*.
- An error occurs in the following cases. *ENO* will be FALSE, and *Out* will not change.
 - The value of *In* is outside of the valid range.
 - The value of *Format* is outside of the valid range.

AryToBCD

The AryToBCD instruction converts the elements of an unsigned integer array to BCD bit strings.

Instruction	Name	FB/FUN	Graphic expression	ST expression
AryToBCD	Array BCD Conversion	FUN	<pre> graph LR EN[EN] --- AryToBCD[(@)AryToBCD] In[In] --- AryToBCD Size[Size] --- AryToBCD AryOut[AryOut] --- AryToBCD AryToBCD --- ENO[ENO] AryToBCD --- Out[Out] </pre>	AryToBCD(In, Size, Ary-Out);

Variables

Name	Meaning	I/O	Description	Valid range	Unit	Default
In[] (array)	Unsigned integer array	Input	Unsigned integer array	*1	---	*2
Size	Number of elements		Number of elements of <i>In[]</i> for conversion	Depends on data type.		1
AryOut[] (array)	BCD array	In-out	BCD array	*1	---	---
Out	Return value	Output	Always TRUE	TRUE only	---	---

*1 The valid ranges depend on the data types of the elements of *In[]* and *AryOut[]*. Refer to *Function* for details.

*2 If you omit an input parameter, the default value is not applied. A building error will occur.

	Boolean	Bit strings					Integers							Real numbers		Times, durations, dates, and text strings				
	BOOL	BYTE	WORD	DWORD	LWORD	USINT	UINT	UDINT	ULINT	SINT	INT	DINT	LINT	REAL	LREAL	TIME	DATE	TOD	DT	STRING
In[] (array)						OK	OK	OK	OK											
Size							OK													
AryOut[] (array)	Must be a bit string array. The data type must be the same size as the elements of <i>In[]</i> .																			
Out	OK																			

Function

The AryToBCD instruction converts *Size* elements of unsigned integer array *In[]* starting from *In[0]* to a BCD bit string. It outputs the BCD bit string to BCD array *AryOut[]*.

The following example is for when *Size* is UINT#3.

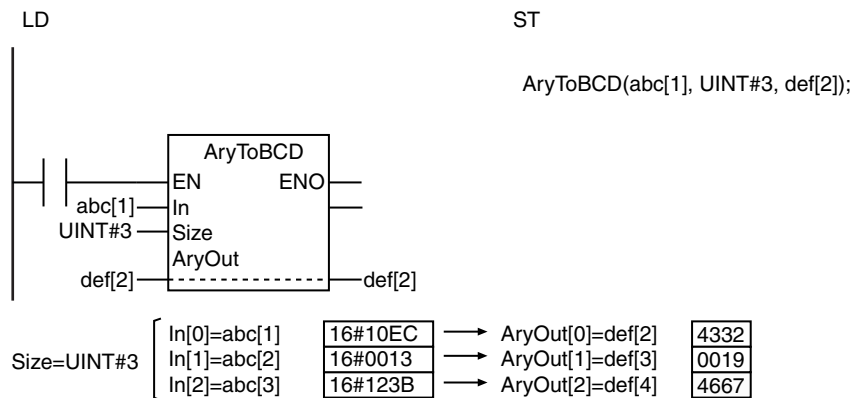

The following table shows the valid ranges for *In[]* and *AryOut[]* according to the data types of their elements.

Data type of the elements of <i>In[]</i>	Data type of the elements of <i>AryOut[]</i>	Valid range of <i>In[]</i>	Valid range of <i>AryOut[]</i>
USINT	BYTE	0 to 99	16#00 to 16#99 (BCD)
UINT	WORD	0 to 9999	16#0000 to 16#9999 (BCD)
UDINT	DWORD	0 to 99999999	16#0000_0000 to 16#9999_9999 (BCD)
ULINT	LWORD	0 to 9999999999999999	16#0000_0000_0000_0000 to 16#9999_9999_9999_9999 (BCD)

Precautions for Correct Use

- Use the same data type and size for *In[]* and *AryOut[]*. For example, if the elements of *In[]* are UINT data, use WORD as the data type of the elements of *AryOut[]*. Otherwise, a building error will occur.
- This instruction does not convert signed binary to signed BCD. Use an unsigned integer (USINT, UINT, UDINT, or ULINT) as the data type of *In[]*.
- The values in *AryOut[]* do not change if the value of *Size* is 0.
- Return value *Out* is not used when the instruction is used in ST.
- An error occurs in the following cases. *ENO* will be FALSE, and *AryOut[]* will not change.
 - The value of *In[]* is outside of the valid range.
 - The value of *Size* exceeds the array area of *In[]* or *AryOut[]*.

AryToBin

The AryToBin instruction converts the elements of an array of BCD bit strings into unsigned integers.

Instruction	Name	FB/FUN	Graphic expression	ST expression
AryToBin	Array Unsigned Integer Conversion	FUN	<pre> graph LR subgraph AryToBin EN[EN] In[In] Size[Size] AryOut[AryOut] ENO[ENO] Out[Out] end EN --- ENO In --- Out Size --- Out AryOut --- Out </pre>	AryToBin(In, Size, AryOut);

Variables

Name	Meaning	I/O	Description	Valid range	Unit	Default
In[] (array)	Array of BCD bit strings	Input	Array of BCD bit strings	*1	---	*2
Size	Number of elements		Number of elements of <i>In[]</i> for conversion	Depends on data type.		1
AryOut[] (array)	Unsigned integer array	In-out	Unsigned integer array	*1	---	---
Out	Return value	Output	Always TRUE	TRUE only	---	---

*1 The valid ranges depend on the data types of the elements of *In[]* and *AryOut[]*. Refer to *Function* for details.

*2 If you omit an input parameter, the default value is not applied. A building error will occur.

	Boolean	Bit string				Integers								Real numbers		Times, durations, dates, and text strings				
	BOOL	BYTE	WORD	DWORD	LWORD	USINT	UINT	UDINT	ULINT	SINT	INT	DINT	LINT	REAL	LREAL	TIME	DATE	TOD	DT	STRING
In[] (array)		OK	OK	OK	OK															
Size							OK													
AryOut[] (array)	Must be an unsigned integer array. The data type must be the same size as the elements of <i>In[]</i> .																			
Out	OK																			

Function

The AryToBin instruction converts *Size* elements of array of BCD bit strings *In[]* starting from *In[0]* to unsigned integers. It outputs the unsigned integers to unsigned integer array *AryOut[]*.

The following example is for when *Size* is UINT#3.

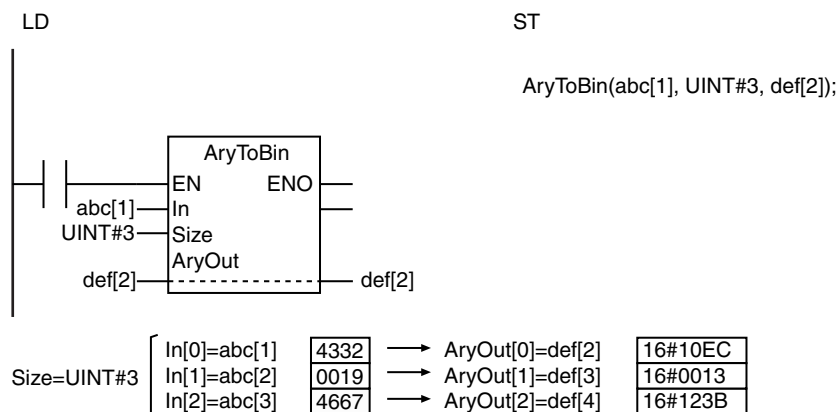

The following table shows the valid ranges for *In[]* and *AryOut[]* according to the data types of their elements.

Data type of the elements of <i>In[]</i>	Data type of the elements of <i>AryOut[]</i>	Valid range of <i>In[]</i>	Valid range of <i>AryOut[]</i>
BYTE	USINT	16#00 to 16#99 (BCD)	0 to 99
WORD	UINT	16#0000 to 16#9999 (BCD)	0 to 9999
DWORD	UDINT	16#0000_0000 to 16#9999_9999 (BCD)	0 to 99999999
LWORD	ULINT	16#0000_0000_0000_0000 to 16#9999_9999_9999_9999 (BCD)	0 to 9999999999999999

Precautions for Correct Use

- Use the same data type and size for *In[]* and *AryOut[]*. For example, if the elements of *In[]* are WORD data, use USINT as the data type of the elements of *AryOut[]*. Otherwise, a building error will occur.
- This instruction does not convert signed BCD to signed binary. Use an unsigned integer (USINT, UINT, UDINT, or ULINT) as the data type of *AryOut[]*.
- The values in *AryOut[]* do not change if the value of *Size* is 0.
- Return value *Out* is not used when the instruction is used in ST.
- An error occurs in the following cases. *ENO* will be FALSE, and *AryOut[]* will not change.
 - The value of *Size* exceeds the array area of *In[]* or *AryOut[]*.
 - A value in *In[]* is not a BCD bit string (i.e., contains A, B, C, D, E, or F hexadecimal).

Data Type Conversion Instructions

Instruction	Name	Page	Instruction	Name	Page
TO* (Integer-to-Integer Conversion Group)	Integer-to-Integer Conversion Group	2-262	RealToFormatString	REAL-to-Formatted Text String	2-289
TO* (Integer-to-Bit String Conversion Group)	Integer-to-Bit String Conversion Group	2-265	LrealToFormatString	LREAL-to-Formatted Text String	2-294
TO* (Integer-to-Real Number Conversion Group)	Integer-to-Real Number Conversion Group	2-268	STRING_TO_** (Text String-to-Integer Conversion Group)	Text String-to-Integer Conversion Group	2-299
TO* (Bit String-to-Integer Conversion Group)	Bit String-to-Integer Conversion Group	2-270	STRING_TO_** (Text String-to-Bit String Conversion Group)	Text String-to-Bit String Conversion Group	2-301
TO* (Bit String-to-Bit String Conversion Group)	Bit String-to-Bit String Conversion Group	2-272	STRING_TO_** (Text String-to-Real Number Conversion Group)	Text String-to-Real Number Conversion Group	2-303
TO* (Bit String-to-Real Number Conversion Group)	Bit String-to-Real Number Conversion Group	2-274	TO_** (Integer Conversion Group)	Integer Conversion Group	2-306
TO* (Real Number-to-Integer Conversion Group)	Real Number-to-Integer Conversion Group	2-276	TO_** (Bit String Conversion Group)	Bit String Conversion Group	2-308
TO* (Real Number-to-Bit String Conversion Group)	Real Number-to-Bit String Conversion Group	2-279	TO_** (Real Number Conversion Group)	Real Number Conversion Group	2-310
TO* (Real Number-to-Real Number Conversion Group)	Real Number-to-Real Number Conversion Group	2-281	EnumToNum	Enumeration-to-Integer	2-312
**_TO_STRING (Integer-to-Text String Conversion Group)	Integer-to-Text String Conversion Group	2-283	NumToEnum	Integer-to-Enumeration	2-314
**_TO_STRING (Bit String-to-Text String Conversion Group)	Bit String-to-Text String Conversion Group	2-285	TRUNC, Round, and RoundUp	Truncate/Round Off Real Number/Round Up Real Number	2-316
**_TO_STRING (Real Number-to-Text String Conversion Group)	Real Number-to-Text String Conversion Group	2-287			

TO (Integer-to-Integer Conversion Group)

These instructions convert integers to integers with different data types.

Instruction	Name	FB/FUN	Graphic expression	ST expression
TO	Integer-to-Integer Conversion Group	FUN	<p>*** and ***** must be different integer data types.</p>	Out:=**_TO_** (In); *** and ***** must be different integer data types.

Variables

Name	Meaning	I/O	Description	Valid range	Unit	Default
In	Data to convert	Input	Data to convert	*	---	0
Out	Conversion result	Output	Conversion result	*	---	---

* The valid ranges depend on the data types of *In* and *Out*. Refer to *Function*, below, for details.

	Boolean	Bit strings					Integers							Real numbers	Times, durations, dates, and text strings					
	BOOL	BYTE	WORD	DWORD	LWORD	USINT	UINT	UDINT	ULINT	SINT	INT	DINT	LINT	REAL	LREAL	TIME	DATE	TOD	DT	STRING
In						OK	OK	OK	OK	OK	OK	OK	OK							
Out						OK	OK	OK	OK	OK	OK	OK	OK							

Function

These instructions convert an integer, *In*, to an integer with a different data type.

The name of the instruction is determined by the data types of *In* and conversion result *Out*. For example, if *In* is INT data and *Out* is DINT data, the name of the instruction is INT_TO_DINT.

The following example for the INT_TO_DINT instruction is for when *In* is INT#1234.

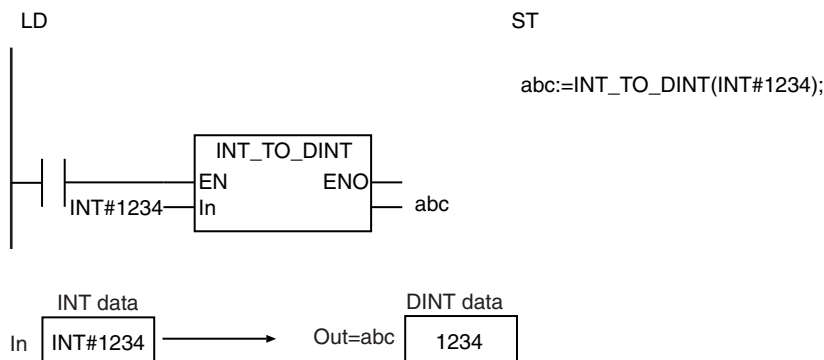

The following table shows the valid ranges for *In* and *Out* according to their data types.

Data type of <i>In</i>	Data type of <i>Out</i>	Valid range for <i>In</i> and <i>Out</i>
USINT	UINT	0 to 255
	UDINT	
	ULINT	
	SINT	0 to 127
	INT	0 to 255
	DINT	
	LINT	
UINT	USINT	0 to 255
	UDINT	0 to 65535
	ULINT	
	SINT	0 to 127
	INT	0 to 32767
	DINT	0 to 65535
	LINT	
UDINT	USINT	0 to 255
	UINT	0 to 65535
	ULINT	0 to 4294967295
	SINT	0 to 127
	INT	0 to 32767
	DINT	0 to 2147483647
	LINT	0 to 4294967295
ULINT	USINT	0 to 255
	UINT	0 to 65535
	UDINT	0 to 4294967295
	SINT	0 to 127
	INT	0 to 32767
	DINT	0 to 2147483647
	LINT	0 to 9223372036854775807
SINT	USINT	0 to 127
	UINT	
	UDINT	
	ULINT	-128 to 127
	INT	
	DINT	
	LINT	
INT	USINT	0 to 255
	UINT	0 to 32767
	UDINT	
	ULINT	
	SINT	-128 to 127
	DINT	-32768 to 32767
LINT		
DINT	USINT	0 to 255
	UINT	0 to 65535
	UDINT	0 to 2147483647
	ULINT	
	SINT	-128 to 127
	INT	-32768 to 32767
LINT	-2147483648 to 2147483647	

Data type of <i>In</i>	Data type of <i>Out</i>	Valid range for <i>In</i> and <i>Out</i>
LINT	USINT	0 to 255
	UINT	0 to 65535
	UDINT	0 to 4294967295
	ULINT	0 to 9223372036854775807
	SINT	-128 to 127
	INT	-32768 to 32767
	DINT	-2147483648 to 2147483647

Additional Information

To convert data with any data type to integer data, use a TO_** (Integer Conversion Group) instruction (page 2-306).

Precautions for Correct Use

- Always use the correct instruction name for the data types of *In* and *Out*.
- If *In* is a signed integer and the data size of *Out* is larger than the data size of *In*, sign extension is performed.
- If *In* is an unsigned integer and the data size of *Out* is larger than the data size of *In*, the upper digits of *Out* will contain 0.
- If the data size of *Out* is smaller than the data size of *In*, the upper digits are truncated in *Out*.

TO* (Integer-to-Bit String Conversion Group)

These instructions convert integers to bit strings.

Instruction	Name	FB/FUN	Graphic expression	ST expression
TO*	Integer-to-Bit String Conversion Group	FUN	<p>*** must be an integer data type. **** must be a bit string data type.</p>	Out:=**_TO_*** (In); **** must be an integer data type. ***** must be a bit string data type.

Variables

Name	Meaning	I/O	Description	Valid range	Unit	Default
In	Data to convert	Input	Data to convert	*	---	0
Out	Conversion result	Output	Conversion result	*	---	---

* The valid ranges depend on the data types of *In* and *Out*. Refer to *Function*, below, for details.

	Boolean	Bit strings					Integers							Real numbers		Times, durations, dates, and text strings					
		BOOL	BYTE	WORD	DWORD	LWORD	USINT	UINT	UDINT	ULINT	SINT	INT	DINT	LINT	REAL	LREAL	TIME	DATE	TOD	DT	STRING
In						OK	OK	OK	OK	OK	OK	OK	OK* ¹								
Out		OK	OK* ¹	OK	OK																

*¹ For an NX1P2 CPU Unit, a CPU Unit with unit version 1.14 or later and Sysmac Studio version 1.18 or higher are required to use the LINT_TO_WORD instruction.

Function

These instructions convert an integer, *In*, to a bit string.

The name of the instruction is determined by the data types of *In* and conversion result *Out*. For example, if *In* is INT data and *Out* is WORD data, the name of the instruction is INT_TO_WORD.

The following example for the INT_TO_WORD instruction is for when *In* is INT#-1234.

LD

ST

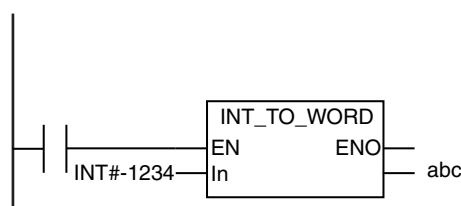

abc:=INT_TO_WORD(INT#-1234);

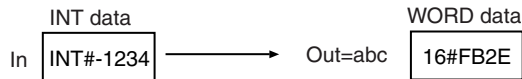

The following table shows the valid ranges for *In* and *Out* according to their data types.

Data type of <i>In</i>	Data type of <i>Out</i>	Valid range for <i>In</i>	Valid range for <i>Out</i>
USINT	BYTE	0 to 255	16#00 to 16#FF
	WORD		
	DWORD		
	LWORD		
UINT	BYTE	0 to 255	16#00 to 16#FF
	WORD	0 to 65535	16#0000 to 16#FFFF
	DWORD		
	LWORD		
UDINT	BYTE	0 to 255	16#00 to 16#FF
	WORD	0 to 65535	16#0000 to 16#FFFF
	DWORD	0 to 4294967295	16#0000_0000 to 16#FFFF_FFFF
	LWORD		
ULINT	BYTE	0 to 255	16#00 to 16#FF
	WORD	0 to 65535	16#0000 to 16#FFFF
	DWORD	0 to 4294967295	16#0000_0000 to 16#FFFF_FFFF
	LWORD	0 to 18446744073709551645	16#0000_0000_0000_0000 to 16#FFFF_FFFF_FFFF_FFFF
SINT	BYTE	-128 to 127	16#00 to 16#FF
	WORD		
	DWORD		
	LWORD		
INT	BYTE	-128 to 127	16#00 to 16#FF
	WORD	-32768 to 32767	16#0000 to 16#FFFF
	DWORD		
	LWORD		
DINT	BYTE	-128 to 127	16#00 to 16#FF
	WORD	-32768 to 32767	16#0000 to 16#FFFF
	DWORD	-2147483648 to 2147483647	16#0000_0000 to 16#FFFF_FFFF
	LWORD		
LINT	BYTE	-128 to 127	16#00 to 16#FF
	WORD	-32768 to 32767	16#0000 to 16#FFFF
	DWORD	-2147483648 to 2147483647	16#0000_0000 to 16#FFFF_FFFF
	LWORD	-9223372036854775808 to 9223372036854775807	16#0000_0000_0000_0000 to 16#FFFF_FFFF_FFFF_FFFF

Additional Information

- To convert a bit string to an integer, use a ****_TO_***** (Bit String-to-Integer Conversion Group) instruction (page 2-270).
- To convert data with any data type to a bit string, use a **TO_**** (Bit String Conversion Group) instruction (page 2-308).

Precautions for Correct Use

- Always use the correct instruction name for the data types of *In* and *Out*.
- If *In* is a signed integer and the data size of *Out* is larger than the data size of *In*, sign extension is performed.

- If *In* is an unsigned integer and the data size of *Out* is larger than the data size of *In*, the upper digits of *Out* will contain 0.
- If the data size of *Out* is smaller than the data size of *In*, the upper digits are truncated in *Out*.

TO (Integer-to-Real Number Conversion Group)

These instructions convert integers to real numbers.

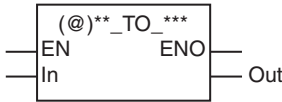
Instruction	Name	FB/FUN	Graphic expression	ST expression
TO	Integer-to-Real Number Conversion Group	FUN	 <p>**** must be an integer data type. **** must be a real number data type.</p>	Out:=**_TO_** (In); **** must be an integer data type. **** must be a real number data type.

Variables

Name	Meaning	I/O	Description	Valid range	Unit	Default
In	Data to convert	Input	Data to convert	*	---	0
Out	Conversion result	Output	Conversion result	*	---	---

* The valid ranges depend on the data types of *In* and *Out*. Refer to *Function*, below, for details.

	Boolean	Bit strings					Integers							Real numbers		Times, durations, dates, and text strings				
	BOOL	BYTE	WORD	DWORD	LWORD	USINT	UINT	UDINT	ULINT	SINT	INT	DINT	LINT	REAL	LREAL	TIME	DATE	TOD	DT	STRING
In						OK	OK	OK	OK	OK	OK	OK	OK							
Out														OK	OK					

Function

These instructions convert an integer, *In*, to a real number.

The name of the instruction is determined by the data types of *In* and conversion result *Out*. For example, if *In* is INT data and *Out* is REAL data, the name of the instruction is INT_TO_REAL.

The following example for the INT_TO_REAL instruction is for when *In* is INT#1234.

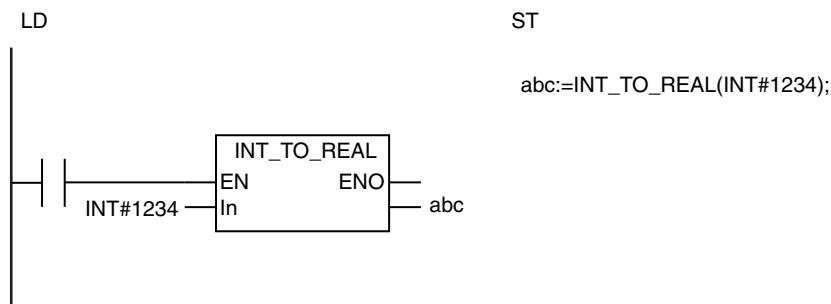

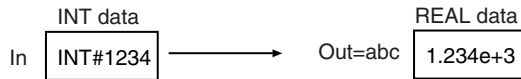

The following table shows the valid ranges for *In* and *Out* according to their data types.

Data type of <i>In</i>	Data type of <i>Out</i>	Valid range for <i>In</i>	Valid range for <i>Out</i>
USINT	REAL	0 to 255	0 to 2.55e+2
	LREAL		
UINT	REAL	0 to 65535	0 to 6.5535e+4
	LREAL		
UDINT	REAL	0 to 4294967295	0 to 4.294967e+9
	LREAL		0 to 4.294967295e+9
ULINT	REAL	0 to 18446744073709551615	0 to 1.844674e+19
	LREAL		0 to 1.84467440737095e+19
SINT	REAL	-128 to 127	-1.28e+2 to 1.27e+2
	LREAL		
INT	REAL	-32768 to 32767	-3.2768e+4 to 3.2767e+4
	LREAL		
DINT	REAL	-2147483648 to 2147483647	-2.147483e+9 to 2.147483e+9
	LREAL		-2.147483648e+9 to 2.147483647e+9
LINT	REAL	-9223372036854775808 to 9223372036854775807	-9.223372e+18 to 9.223372e+18
	LREAL		-9.22337203685477e+18 to 9.22337203685477e+18

Additional Information

- To convert a real number to an integer, use a ****_TO_***** (Real Number-to-Integer Conversion Group) instruction (page 2-276).
- To convert data with any data type to a real number, use a **TO_**** (Real Number Conversion Group) instruction (page 2-310).

Precautions for Correct Use

- Always use the correct instruction name for the data types of *In* and *Out*.
- Depending on the data types of *In* and *Out*, rounding will be performed for the effective digits of the real number. This will cause error between the values before and after conversion. The following table lists the data types that result in error.

Data type of <i>In</i>	Data type of <i>Out</i>	Values for which error occurs
DINT	REAL	-16777216 or lower, or 16777216 or higher
LINT		
UDINT	REAL	16777216 or higher
ULINT		
LINT	LREAL	-9007199254740992 or lower, or 9007199254740992 or higher
ULINT	LREAL	9007199254740992 or higher

TO (Bit String-to-Integer Conversion Group)

These instructions convert bit strings to integers.

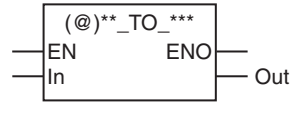
Instruction	Name	FB/FUN	Graphic expression	ST expression
TO	Bit String-to-Integer Conversion Group	FUN	 <p>**** must be a bit string data type. **** must be an integer data type.</p>	Out:=**_TO_** (In); **** must be a bit string data type. **** must be an integer data type.

Variables

Name	Meaning	I/O	Description	Valid range	Unit	Default
In	Data to convert	Input	Data to convert	*	---	0
Out	Conversion result	Output	Conversion result	*	---	---

* The valid ranges depend on the data types of *In* and *Out*. Refer to *Function*, below, for details.

	Boolean	Bit strings					Integers							Real numbers	Times, durations, dates, and text strings					
	BOOL	BYTE	WORD	DWORD	LWORD	USINT	UINT	UDINT	ULINT	SINT	INT	DINT	LINT	REAL	LREAL	TIME	DATE	TOD	DT	STRING
In		OK	OK	OK	OK															
Out						OK	OK	OK	OK	OK	OK	OK	OK							

Function

These instructions convert a bit string, *In*, to an integer.

The name of the instruction is determined by the data types of *In* and conversion result *Out*. For example, if *In* is WORD data and *Out* is INT data, the name of the instruction is WORD_TO_INT.

The following example for the WORD_TO_INT instruction is for when *In* is WORD #16#1234.

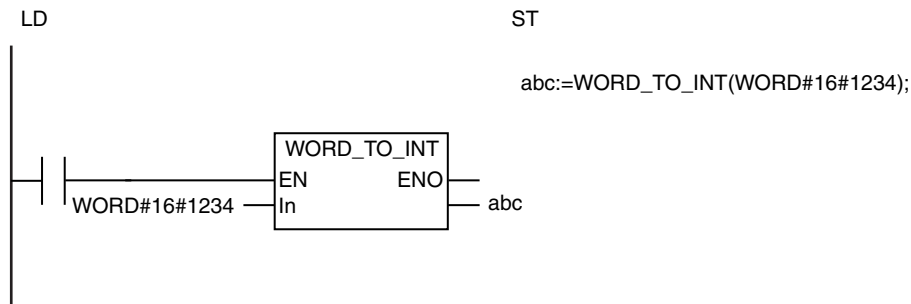



The following table shows the valid ranges for *In* and *Out* according to their data types.

Data type of <i>In</i>	Data type of <i>Out</i>	Valid range for <i>In</i>	Valid range for <i>Out</i>
BYTE	USINT	16#00 to 16#FF	0 to 255
	UINT		
	UDINT		
	ULINT		
	SINT		-128 to 127
	INT		
	DINT		
	LINT		
WORD	USINT	16#00 to 16#FF	0 to 255
	UINT	16#0000 to 16#FFFF	0 to 65535
	UDINT		
	ULINT		
	SINT	16#00 to 16#FF	-128 to 127
	INT	16#0000 to 16#FFFF	-32768 to 32767
	DINT		
	LINT		
DWORD	USINT	16#00 to 16#FF	0 to 255
	UINT	16#0000 to 16#FFFF	0 to 65535
	UDINT	16#0000_0000 to 16#FFFF_FFFF	0 to 4294967295
	ULINT		
	SINT	16#00 to 16#FF	-128 to 127
	INT	16#0000 to 16#FFFF	-32768 to 32767
	DINT	16#0000_0000 to 16#FFFF_FFFF	-2147483648 to 2147483647
	LINT		
LWORD	USINT	16#00 to 16#FF	0 to 255
	UINT	16#0000 to 16#FFFF	0 to 65535
	UDINT	16#0000_0000 to 16#FFFF_FFFF	0 to 4294967295
	ULINT	16#0000_0000_0000_0000 to 16#FFFF_FFFF_FFFF_FFFF	0 to 18446744073709551645
	SINT	16#00 to 16#FF	-128 to 127
	INT	16#0000 to 16#FFFF	-32768 to 32767
	DINT	16#0000_0000 to 16#FFFF_FFFF	-2147483648 to 2147483647
	LINT	16#0000_0000_0000_0000 to 16#FFFF_FFFF_FFFF_FFFF	-9223372036854775808 to 9223372036854775807

Additional Information

- To convert an integer to a bit string, use a ****_TO_***** (Integer-to-Bit String Conversion Group) instruction (page 2-265).
- To convert data with any data type to a bit string, use a **TO_**** (Bit String Conversion Group) instruction (page 2-308).

Precautions for Correct Use

- Always use the correct instruction name for the data types of *In* and *Out*.
- If the data size of *Out* is larger than the data size of *In*, the upper digits of *Out* will contain 0.
- If the data size of *Out* is smaller than the data size of *In*, the upper digits are truncated in *Out*.

TO (Bit String-to-Bit String Conversion Group)

These instructions convert bit strings to bit strings with different data types.

Instruction	Name	FB/FUN	Graphic expression	ST expression
TO	Bit String-to-Bit String Conversion Group	FUN	<p>*** and ***** must be different bit string data types.</p>	Out:=**_TO_** (In); ***** and ***** must be different bit string data types.

Variables

Name	Meaning	I/O	Description	Valid range	Unit	Default
In	Data to convert	Input	Data to convert	*	---	0
Out	Conversion result	Output	Conversion result	*	---	---

* The valid ranges depend on the data types of *In* and *Out*. Refer to *Function*, below, for details.

	Boolean	Bit strings					Integers							Real numbers	Times, durations, dates, and text strings					
	BOOL	BYTE	WORD	DWORD	LWORD	USINT	UINT	UDINT	ULINT	SINT	INT	DINT	LINT	REAL	LREAL	TIME	DATE	TOD	DT	STRING
In		OK	OK	OK	OK															
Out		OK	OK	OK	OK															

Function

These instructions convert a bit string, *In*, to a bit string with a different data type.

The name of the instruction is determined by the data types of *In* and conversion result *Out*. For example, if *In* is WORD data and *Out* is DWORD data, the name of the instruction is WORD_TO_DWORD.

The following example for the WORD_TO_DWORD instruction is for when *In* is WORD#16#F123.

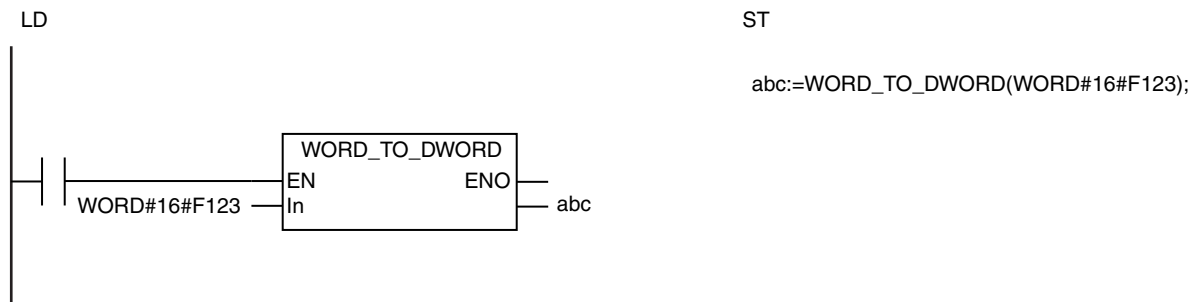

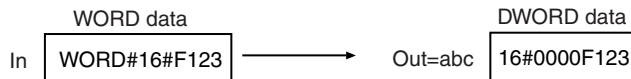

The following table shows the valid ranges for *In* and *Out* according to their data types.

Data type of <i>In</i>	Data type of <i>Out</i>	Valid range for <i>In</i> and <i>Out</i>
BYTE	WORD	16#00 to 16#FF
	DWORD	
	LWORD	
WORD	BYTE	16#00 to 16#FF
	DWORD	16#0000 to 16#FFFF
	LWORD	
DWORD	BYTE	16#00 to 16#FF
	WORD	16#0000 to 16#FFFF
	LWORD	16#0000_0000 to 16#FFFF_FFFF
LWORD	BYTE	16#00 to 16#FF
	WORD	16#0000 to 16#FFFF
	DWORD	16#0000_0000 to 16#FFFF_FFFF

Additional Information

To convert data with any data type to a bit string, use a `TO_**` (Bit String Conversion Group) instruction (page 2-308).

Precautions for Correct Use

- Always use the correct instruction name for the data types of *In* and *Out*.
- If the data size of *Out* is larger than the data size of *In*, the upper digits of *Out* will contain 0.
- If the data size of *Out* is smaller than the data size of *In*, the upper digits are truncated when the data is output to *Out*.

TO (Bit String-to-Real Number Conversion Group)

These instructions convert bit strings to real numbers.

Instruction	Name	FB/FUN	Graphic expression	ST expression
TO	Bit String-to-Real Number Conversion Group	FUN	<p>**** must be a bit string data type. ***** must be a real number data type.</p>	Out:=**_TO_** (In); **** must be a bit string data type. ***** must be a real number data type.

Variables

Name	Meaning	I/O	Description	Valid range	Unit	Default
In	Data to convert	Input	Data to convert	*	---	0
Out	Conversion result	Output	Conversion result	*	---	---

* The valid ranges depend on the data types of *In* and *Out*. Refer to *Function*, below, for details.

	Boolean	Bit strings					Integers							Real numbers		Times, durations, dates, and text strings				
	BOOL	BYTE	WORD	DWORD	LWORD	USINT	UINT	UDINT	ULINT	SINT	INT	DINT	LINT	REAL	LREAL	TIME	DATE	TOD	DT	STRING
In		OK	OK	OK	OK															
Out														OK	OK					

Function

These instructions take a bit string, *In*, as an unsigned integer of the same size and convert it to a real number.

The name of the instruction is determined by the data types of *In* and conversion result *Out*. For example, if *In* is WORD data and *Out* is REAL data, the name of the instruction is WORD_TO_REAL.

The following example for the WORD_TO_REAL instruction is for when *In* is WORD#16#8000.

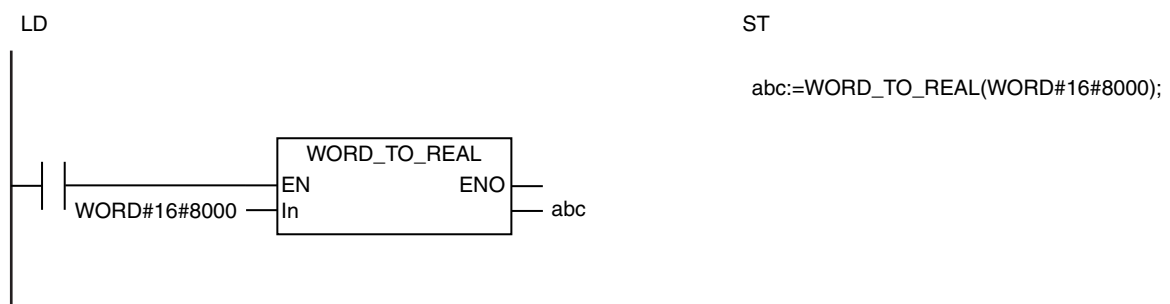

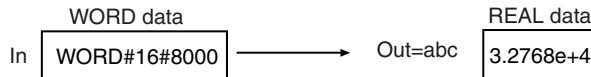

The following table shows the valid ranges for *In* and *Out* according to their data types.

Data type of <i>In</i>	Data type of <i>Out</i>	Valid range for <i>In</i>	Valid range for <i>Out</i>
BYTE	REAL	16#00 to 16#FF	0 to 2.55e+2
	LREAL		
WORD	REAL	16#0000 to 16#FFFF	0 to 6.5535e+4
	LREAL		
DWORD	REAL	16#0000_0000 to 16#FFFF_FFFF	0 to 4.294967e+9
	LREAL		0 to 4.294967295e+9
LWORD	REAL	16#0000_0000_0000_0000 to 16#FFFF_FFFF_FFFF_FFFF	0 to 1.844674e+19
	LREAL		0 to 1.84467440737095e+19

Additional Information

- To convert a real number to a bit string, use a ****_TO_**** (Real Number-to-Bit String Conversion Group) instruction (page 2-279).
- To convert data with any data type to a real number, use a **TO_**** (Real Number Conversion Group) instruction (page 2-310).

Precautions for Correct Use

- Always use the correct instruction name for the data types of *In* and *Out*.
- Depending on the data types of *In* and *Out*, rounding will be performed for the effective digits of the real number. This will cause error between the values before and after conversion. The following table lists the data types that result in error.

Data type of <i>In</i>	Data type of <i>Out</i>	Values for which error occurs
DWORD	REAL	16#0100_0000 or higher
LWORD	LREAL	16#0002_0000_0000_0000 or higher

TO (Real Number-to-Integer Conversion Group)

These instructions convert real numbers to integers.

Instruction	Name	FB/FUN	Graphic expression	ST expression
TO	Real Number-to-Integer Conversion Group	FUN	<p>*** must be a real number data type. **** must be an integer data type.</p>	Out:=**_TO_** (In); *** must be a real number data type. **** must be an integer data type.

Variables

Name	Meaning	I/O	Description	Valid range	Unit	Default
In	Data to convert	Input	Data to convert	*	---	0
Out	Conversion result	Output	Conversion result	*	---	---

* The valid ranges depend on the data types of *In* and *Out*. Refer to *Function*, below, for details.

	Boolean	Bit strings					Integers							Real numbers		Times, durations, dates, and text strings					
		BOOL	BYTE	WORD	DWORD	LWORD	USINT	UINT	UDINT	ULINT	SINT	INT	DINT	LINT	REAL	LREAL	TIME	DATE	TOD	DT	STRING
In														OK	OK						
Out						OK	OK	OK	OK	OK	OK	OK	OK								

Function

These instructions convert a real number, *In*, to an integer.

The name of the instruction is determined by the data types of *In* and conversion result *Out*. For example, if *In* is LREAL data and *Out* is LINT data, the name of the instruction is LREAL_TO_LINT.

The following example for the LREAL_TO_LINT instruction is for when *In* is LREAL#1.0e+10.

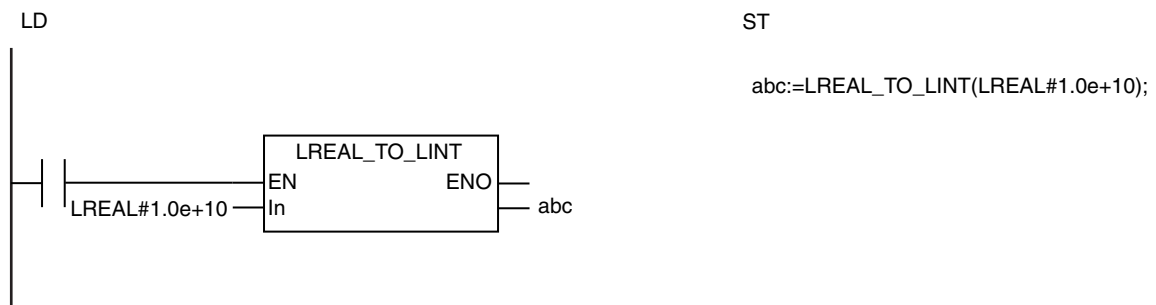

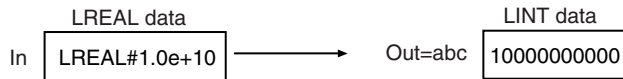

The fractional part of the value of *In* is rounded off to the closest integer. The following table shows how values are rounded.

Value of fractional part	Treatment	Examples
Less than 0.5	The fractional part is truncated.	1.49 → 1 -1.49 → -1
0.5	If the ones digit is an even number, the fractional part is truncated. If it is an odd number, the value is rounded up.	1.50 → 2 2.50 → 2 -1.50 → -2 -2.50 → -2
Greater than 0.5	The fractional part is rounded up.	1.51 → 2 -1.51 → -2

The following table shows the valid ranges for *In* and *Out* according to their data types.

Data type of <i>In</i>	Data type of <i>Out</i>	Valid range for <i>In</i>	Valid range for <i>Out</i>
REAL	USINT	0 to 2.55e+2	0 to 255
	UINT	0 to 6.5535e+4	0 to 65535
	UDINT	0 to 4.294967e+9	0 to 4294967295
	ULINT	0 to 1.844674e+19	0 to 18446744073709551615
	SINT	-1.28e+2 to 1.27e+2	-128 to 127
	INT	-3.2768e+4 to 3.2767e+4	-32768 to 32767
	DINT	-2.147483e+9 to 2.147483e+9	-2147483648 to 2147483647
	LINT	-9.223372e+18 to 9.223372e+18	-9223372036854775808 to 9223372036854775807
LREAL	USINT	0 to 0.255e+3	0 to 255
	UINT	0 to 6.5535e+4	0 to 65535
	UDINT	0 to 4.294967295e+9	0 to 4294967295
	ULINT	0 to 1.84467440737095e+19	0 to 18446744073709551615
	SINT	-1.28e+2 to 1.27e+2	-128 to 127
	INT	-3.2768e+4 to 3.2767e+4	-32768 to 32767
	DINT	-2.147483648e+9 to 2.147483647e+9	-2147483648 to 2147483647
	LINT	-9.22337203685477e+18 to 9.22337203685477e+18	-9223372036854775808 to 9223372036854775807

Additional Information

- To convert an integer to a real number, use an Integer-to-Real Number Conversion Group Instruction.
- To convert data with any data type to an integer, use an Integer Conversion Group Instruction.
- You can use the following instructions to convert a real number to an integer: TRUNC (Truncate), Round (Round Off Real Number), and RoundUp (Round Up Real Number). All of these instructions have a REAL input and DINT output, or a LREAL input and LINT output. The differences between these instructions are shown in the following table.

Input value	Output value			
	REAL_TO_INT	TRUNC	Round	RoundUp
REAL#1.6	INT#2	DINT#1	DINT#2	DINT#2
REAL#1.5	INT#2	DINT#1	DINT#2	DINT#2
REAL#1.5	INT#1	DINT#1	DINT#1	DINT#2
REAL#2.5	INT#2	DINT#2	DINT#2	DINT#3
REAL#-1.6	INT#-2	DINT#-1	DINT#-2	DINT#-2
REAL#-1.5	INT#-2	DINT#-1	DINT#-2	DINT#-2
REAL#-1.4	INT#-1	DINT#-1	DINT#-1	DINT#-2
REAL#-2.5	INT#-2	DINT#-2	DINT#-2	DINT#-3

Precautions for Correct Use

- Always use the correct instruction name for the data types of *In* and *Out*.
- If the conversion result exceeds the valid range of *Out*, *Out* will contain an undefined value. Always make sure that the value of *In* is within the valid range so that the conversion result will not exceed the valid range of *Out*.

TO* (Real Number-to-Bit String Conversion Group)

These instructions convert real numbers to bit strings.

Instruction	Name	FB/FUN	Graphic expression	ST expression
TO*	Real Number-to-Bit String Conversion Group	FUN	<p>*** must be a real number data type. **** must be a bit string data type.</p>	Out:=**_TO_*** (In); **** must be a real number data type. **** must be a bit string data type.

Variables

Name	Meaning	I/O	Description	Valid range	Unit	Default
In	Data to convert	Input	Data to convert	Depends on data type.	---	0
Out	Conversion result	Output	Conversion result	Depends on data type.	---	---

	Boolean	Bit strings					Integers							Real numbers	Times, durations, dates, and text strings					
	BOOL	BYTE	WORD	DWORD	LWORD	USINT	UINT	UDINT	ULINT	SINT	INT	DINT	LINT	REAL	LREAL	TIME	DATE	TOD	DT	STRING
In														OK	OK					
Out		OK	OK	OK	OK															

Function

These instructions convert a real number, *In*, to a bit string.

The name of the instruction is determined by the data types of *In* and conversion output *Out*. For example, if *In* is LREAL data and *Out* is DWORD data, the name of the instruction is LREAL_TO_DWORD.

The following example for the LREAL_TO_DWORD instruction is for when *In* is LREAL#6.5536e+4.

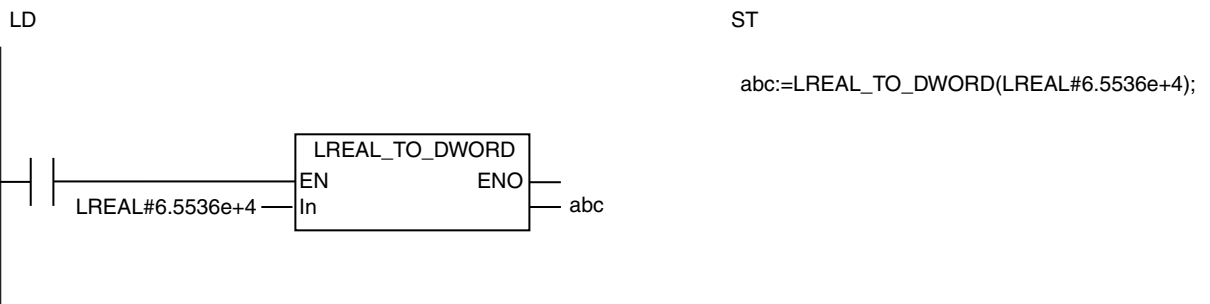

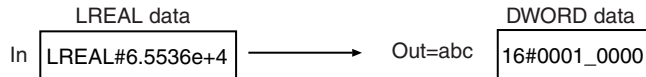

Conversion is performed using the following procedure.

- 1** The fractional part of the value of *In* is rounded off to the closest integer as described below.
- 2** The resulting integer is taken as an unsigned integer and output as a bit string.

The following table shows how values are rounded.

Value of fractional part	Treatment	Examples
Less than 0.5	The fractional part is truncated.	1.49 → 1
0.5	If the ones digit is an even number, the fractional part is truncated. If it is an odd number, the value is rounded up.	1.50 → 2 2.50 → 2
Greater than 0.5	The fractional part is rounded up.	1.51 → 2

The following table gives some conversion examples.

Value of <i>In</i>	Integer	Value of <i>Out</i>
1.6	2	16#0002
3.5	4	16#0004

Additional Information

To convert a bit string to a real number, use a ****_TO_**** (Bit String-to-Real Number Conversion Group) instruction (page 2-274).

Precautions for Correct Use

- Always use the correct instruction name for the data types of *In* and *Out*.
- If the conversion result exceeds the valid range of *Out*, *Out* will contain an undefined value. Always make sure that the value of *In* is within the valid range so that the conversion result will not exceed the valid range of *Out*.
- When you input a negative value, the conversion result depends on the CPU Unit model. If you input a negative value, sufficiently debug before use.

TO (Real Number-to-Real Number Conversion Group)

These instructions convert real numbers to real numbers with different data types.

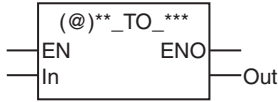
Instruction	Name	FB/FUN	Graphic expression	ST expression
TO	Real Number-to-Real Number Conversion Group	FUN	 <p>*** and ***** must be different real number data types.</p>	Out:=**_TO_** (In); ***** and ***** must be different real number data types.

Variables

Name	Meaning	I/O	Description	Valid range	Unit	Default
In	Data to convert	Input	Data to convert	*	---	0
Out	Conversion result	Output	Conversion result	*	---	---

* The valid ranges depend on the data types of *In* and *Out*. Refer to *Function*, below, for details.

	Boolean	Bit strings					Integers							Real numbers		Times, durations, dates, and text strings					
	BOOL	BYTE	WORD	DWORD	LWORD	USINT	UINT	UDINT	ULINT	SINT	INT	DINT	LINT	REAL	LREAL	TIME	DATE	TOD	DT	STRING	
In														OK	OK						
Out														OK	OK						

Function

These instructions convert a real number, *In*, to a real number with a different data type.

The name of the instruction is determined by the data types of *In* and conversion result *Out*. For example, if *In* is REAL data and *Out* is LREAL data, the name of the instruction is REAL_TO_LREAL.

The following example for the REAL_TO_LREAL instruction is for when *In* is REAL#3.141592e+0.

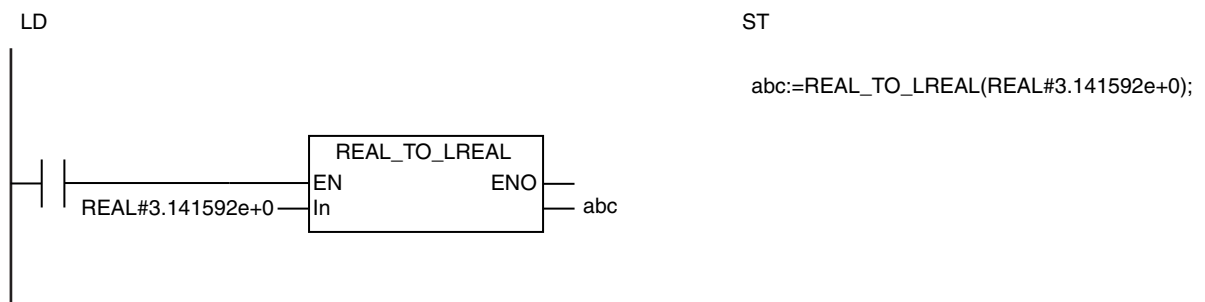



The following table shows the valid ranges for *In* and *Out* according to their data types.

Data type of <i>In</i>	Data type of <i>Out</i>	Valid range for <i>In</i> and <i>Out</i>
REAL	LREAL	-3.402823e+38 to 3.402823e+38
LREAL	REAL	or $+\infty/-\infty$

Additional Information

To convert data with any data type to a real number, use a TO_** (Real Number Conversion Group) instruction (page 2-310).

Precautions for Correct Use

- Always use the correct instruction name for the data types of *In* and *Out*.
- If the value of *In* is positive or negative infinity, the value of *Out* is positive or negative infinity.
- If the value of *In* is nonnumeric data, the value of *Out* is nonnumeric data.
- If the conversion result exceeds the valid range of *Out*, the value of *Out* will be infinity with the same sign as the value of *In*.
- For the LREAL_TO_REAL instruction, if the value of *In* is closer to 0 than $\pm 1.175494e-38$, the value of *Out* will be 0.

**_TO_STRING (Integer-to-Text String Conversion Group)

These instructions convert integers to text strings.

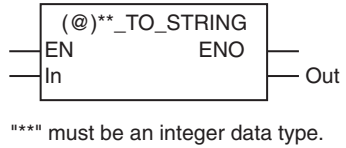
Instruction	Name	FB/FUN	Graphic expression	ST expression
_TO_STRING	Integer-to-Text String Conversion Group	FUN		Out:=_TO_STRING(In); "*** must be an integer data type.

Variables

Name	Meaning	I/O	Description	Valid range	Unit	Default
In	Data to convert	Input	Data to convert	Depends on data type.	---	0
Out	Conversion result	Output	Conversion result	*	---	---

* The valid range depends on the data type of *In*. Refer to *Function* for details.

	Boolean	Bit strings				Integers							Real numbers	Times, durations, dates, and text strings							
		BOOL	BYTE	WORD	DWORD	LWORD	USINT	UINT	UDINT	ULINT	SINT	INT		DINT	LINT	REAL	LREAL	TIME	DATE	TOD	DT
In						OK	OK	OK	OK	OK	OK	OK	OK								
Out																					OK

Function

These instructions convert an integer, *In*, to a text string. The number given in *In* is output to conversion result *Out* as a text string. A NULL character (16#00) is placed at the end of *Out*.

The text in *Out* is left-aligned. If the value in *In* requires fewer digits than provided by the data type of *In*, zeros will not be output to the upper digits of *Out*. In other words, leading zeros are suppressed. If *In* contains a negative value, a minus sign (–) is added to the front of the text string.

The name of the instruction is determined by the data type of *In*. For example, if *In* is the INT data type, the instruction is INT_TO_STRING.

The following example for the INT_TO_STRING instruction is for when *In* is INT#1234.

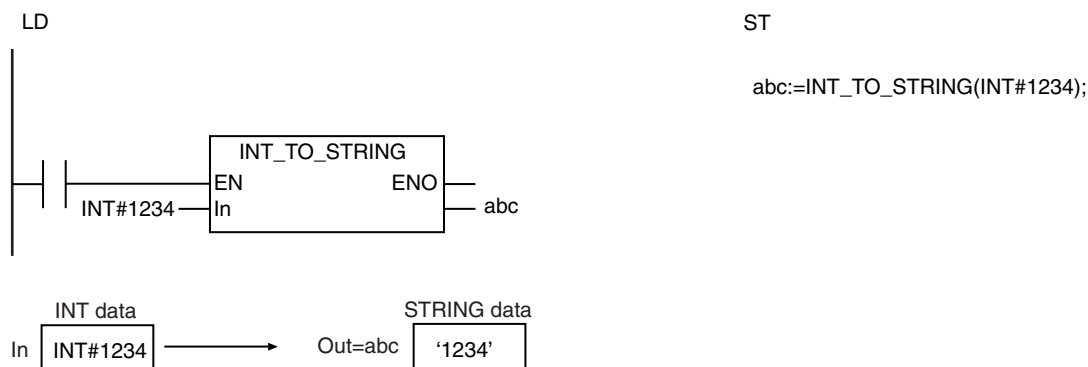

The valid range of *Out* depends on the data type of *In* as shown below:

Data type of <i>In</i>	Valid range of <i>Out</i> (maximum number of bytes)
USINT	4 bytes (three single-byte alphanumeric characters plus the final NULL character)
UINT	6 bytes (five single-byte alphanumeric characters plus the final NULL character)
UDINT	11 bytes (10 single-byte alphanumeric characters plus the final NULL character)
ULINT	21 bytes (20 single-byte alphanumeric characters plus the final NULL character)
SINT	5 bytes (four single-byte alphanumeric characters plus the final NULL character)
INT	7 bytes (six single-byte alphanumeric characters plus the final NULL character)
DINT	12 bytes (11 single-byte alphanumeric characters plus the final NULL character)
LINT	21 bytes (20 single-byte alphanumeric characters plus the final NULL character)

Additional Information

To convert a text string number to an integer, use a STRING_TO_** (Text String-to-Integer Conversion Group) instruction (page 2-299).

Precautions for Correct Use

- Always use the correct instruction name for the data type of *In*.

**_TO_STRING (Bit String-to-Text String Conversion Group)

These instructions convert bit strings to text strings.

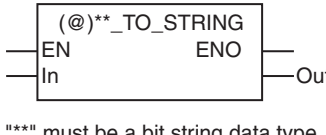
Instruction	Name	FB/FUN	Graphic expression	ST expression
_TO_STRING	Bit String-to-Text String Conversion Group	FUN	 <p>* must be a bit string data type.</p>	Out:=**_TO_STRING(In); "*** must be a bit string data type.

Variables

Name	Meaning	I/O	Description	Valid range	Unit	Default
In	Data to convert	Input	Data to convert	Depends on data type.	---	0
Out	Conversion result	Output	Conversion result	*	---	---

* The valid range depends on the data type of *In*. Refer to *Function* for details.

	Boolean	Bit strings				Integers							Real numbers	Times, durations, dates, and text strings						
	BOOL	BYTE	WORD	DWORD	LWORD	USINT	UINT	UDINT	ULINT	SINT	INT	DINT	LINT	REAL	LREAL	TIME	DATE	TOD	DT	STRING
In		OK	OK	OK	OK															
Out																				OK

Function

These instructions convert a bit string, *In*, to a text string. The hexadecimal number given in *In* is output to conversion result *Out* as a text string. The #16 prefix of the hexadecimal number is not output to *Out*. A NULL character (16#00) is placed at the end of *Out*.

The text in *Out* is left-aligned. If the value in *In* requires fewer digits than provided by the data type of *In*, the upper digits of *Out* will contain 0. In other words, the unused digits are padded with zeros. The number of bytes in *Out* (including the NULL character) will always be one greater than twice the number of bytes in *In*.

The name of the instruction is determined by the data type of *In*. For example, if *In* is the WORD data type, the instruction is WORD_TO_STRING.

The following example for the WORD_TO_STRING instruction is for when *In* is WORD#16#1F.

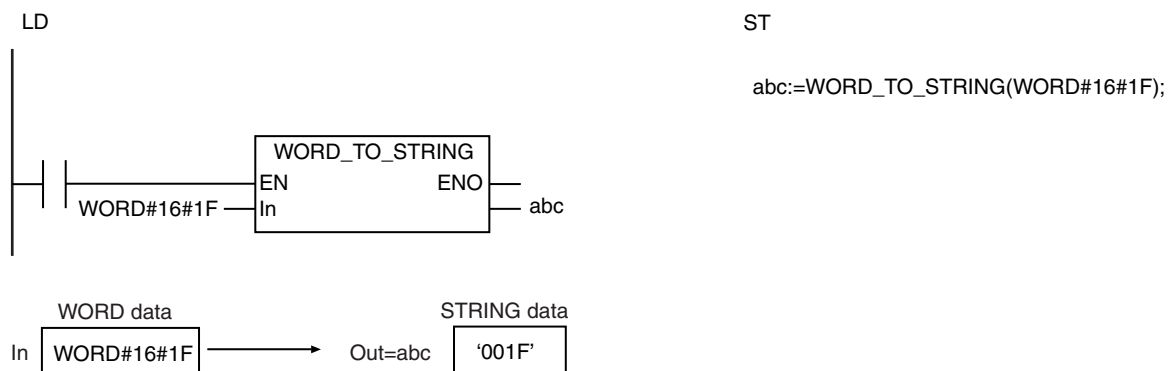

The valid range of *Out* depends on the data type of *In* as shown below:

Data type of <i>In</i>	Valid range of <i>Out</i> (maximum number of bytes)
BYTE	3 bytes (two single-byte alphanumeric characters plus the final NULL character)
WORD	5 bytes (four single-byte alphanumeric characters plus the final NULL character)
DWORD	9 bytes (eight single-byte alphanumeric characters plus the final NULL character)
LWORD	17 bytes (16 single-byte alphanumeric characters plus the final NULL character)

Additional Information

To convert *In* to a signed text string, first convert it to a signed integer using a `**_TO_***` (Bit String-to-Integer Conversion Group) instruction (page 2-270) and then use a `**_TO_STRING` (Integer-to-Text String Conversion Group) instruction (page 2-283).

Precautions for Correct Use

- Always use the correct instruction name for the data type of *In*.

**_TO_STRING (Real Number-to-Text String Conversion Group)

These instructions convert real numbers to text strings.

Instruction	Name	FB/FUN	Graphic expression	ST expression
_TO_STRING	Real Number-to-Text String Conversion Group	FUN	<p>(@)_TO_STRING EN ENO In Out</p> <p>**** must be a real number data type.</p>	Out:=**_TO_STRING(In); **** must be a real number data type.

Variables

Name	Meaning	I/O	Description	Valid range	Unit	Default
In	Data to convert	Input	Data to convert	Depends on data type.	---	0.0
Out	Conversion result	Output	Conversion result	*	---	---

* The valid range depends on the data type of *In*. Refer to *Function* for details.

	Boolean	Bit strings				Integers							Real numbers	Times, durations, dates, and text strings						
	BOOL	BYTE	WORD	DWORD	LWORD	USINT	UINT	UDINT	ULINT	SINT	INT	DINT	LINT	REAL	LREAL	TIME	DATE	TOD	DT	STRING
In														OK	OK					
Out																				OK

Function

These instructions convert a real number, *In*, to a text string. *In* is expressed as an alphanumeric text string and output to conversion result *Out*.

The format of *Out* is as follows:

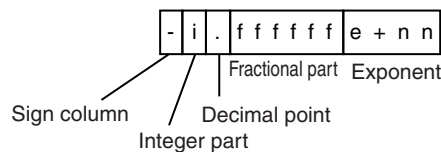

Item	Description
Sign column	If <i>In</i> contains a negative value, a minus sign (–) is added. If <i>In</i> contains a positive value, a plus sign (+) is not added.
Integer part	The integer part is always only one digit.
Decimal point	The decimal point is always given even if <i>In</i> is not a decimal number.
Fractional part	If <i>In</i> is REAL data, 6 digits are given. If <i>In</i> is LREAL data, 14 digits are given.
Exponent	The exponent is always given. “nn” is 2 or 3 digits. The sign of “nn” is positive (+) if the absolute value of <i>In</i> is 1.0 or higher and negative (–) if it is less than 1.0.

A NULL character (16#00) is placed at the end of *Out*.

The name of the instruction is determined by the data type of *In*. For example, if *In* is the REAL data type, the instruction is REAL_TO_STRING.

The following example shows the REAL_TO_STRING instruction when *In* is REAL#–1234.567.

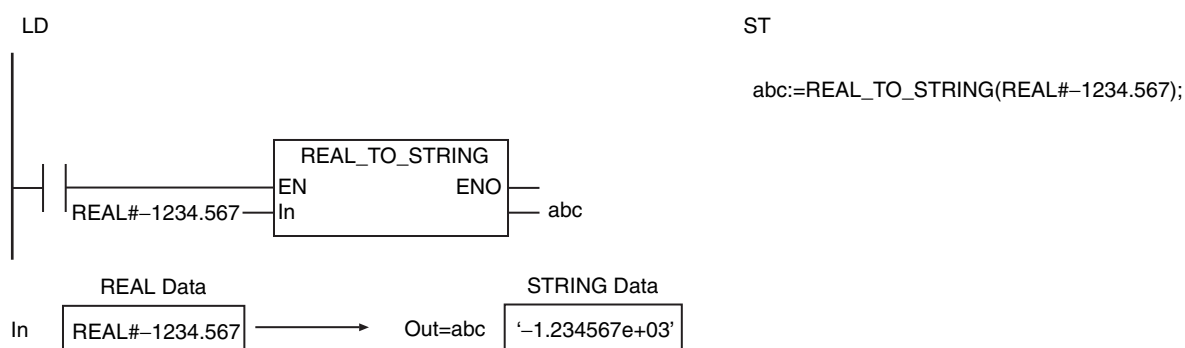

If the value of *In* is 0, infinity, or nonnumeric data, the value of *Out* is as shown below.

Value of <i>In</i>	Value of <i>Out</i>
0	0
+∞	inf
–∞	–inf
Nonnumeric data	'nan' or '–nan'

Additional Information

- To convert a text string to a real number, use a STRING_TO_** (Text String-to-Real Number Conversion Group) instruction (page 2-303).
- To specify the format when you convert a real number to a text string, use the RealToFormatString instruction (page 2-289) or the LrealToFormatString instruction (page 2-294).

Precautions for Correct Use

- Always use the correct instruction name for the data type of *In*.

RealToFormatString

The RealToFormatString instruction converts a REAL variable to a text string with the specified format.

Instruction	Name	FB/FUN	Graphic expression	ST expression
RealToFormatString	REAL-to-Formatted Text String	FUN		Out:=RealToFormatString(In, Exponent, Sign, MinLen, DecPlace);

Variables

Name	Meaning	I/O	Description	Valid range	Unit	Default
In	Data to convert	Input	Data to convert	Depends on data type.	---	0.0
Exponent	Exponent		TRUE: Exponent FALSE: No exponent			FALSE
Sign	Sign column		TRUE: Sign column FALSE: No sign column			
MinLen	Minimum number of digits		Minimum number of digits in <i>Out</i>			6
DecPlace	Precision		Number of decimal digits in <i>Out</i>			0 to 15
Out	Conversion result	Output	Conversion result	327 bytes max. (326 single-byte alphanumeric characters plus the final NULL character)	---	---

	Boolean	Bit strings				Integers							Real numbers		Times, durations, dates, and text strings						
	BOOL	BYTE	WORD	DWORD	LWORD	USINT	UINT	UDINT	ULINT	SINT	INT	DINT	LINT	REAL	LREAL	TIME	DATE	TOD	DT	STRING	
In														OK							
Exponent	OK																				
Sign	OK																				
MinLen						OK															
DecPlace						OK															
Out																					OK

Function

The RealToFormatString instruction converts REAL variable *In* to a text string. *In* is expressed as an alphanumeric text string and output to conversion result *Out*. A NULL character (16#00) is placed at the end of *Out*.

If *In* contains a negative value, a minus sign (–) is added to the front of the text string. If *In* contains a positive value, a plus sign (+) is not added to the front of the text string.

The format of *Out* is determined by exponent *Exponent*, sign column *Sign*, minimum number of digits *MinLen*, and precision *DecPlace*.

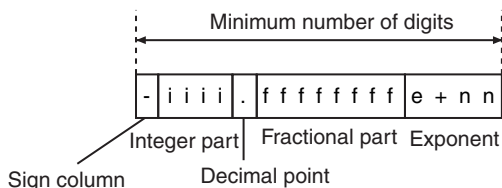

Input variable	Description
Exponent	<i>Exp</i> specifies whether an exponent is given. TRUE: Exponent FALSE: No exponent
Sign	<i>Sign</i> specifies whether there is a sign column. TRUE: Sign column FALSE: No sign column The sign column is used only for a minus sign (–). If the number is positive when the sign column is specified, the sign column will contain a blank character. If the number is negative when no sign column is specified, a minus sign (–) will be added to the front of the integer part. However, if the number of digits in the conversion result exceeds the value of <i>MinLen</i> and the conversion result is positive, the highest digit is placed in the sign column.
MinLen	<i>MinLen</i> is the minimum number of total digits for the sign column, integer part, decimal point, fractional part, and exponent. If the conversion result has fewer digits than the value of <i>MinLen</i> , the text string will be right-aligned (except for the sign column) and remaining digits will contain blank characters. If the number of digits in the conversion result exceeds the value of <i>MinLen</i> , the text string is left-aligned and the text string for the digits that exceed the value of <i>MinLen</i> is assigned to <i>Out</i> .
DecPlace	<i>DecPlace</i> is the number of digits in the fractional part. If the number of digits exceeds the value of <i>DecPlace</i> , the extra digits in the fractional portion are rounded off as described below. If the value of <i>DecPlace</i> is 0, the fractional part and decimal point are not given.

The following examples show the relationships between the values of the input variables and the value of *Out* when *In* is REAL#–1234.567.

Example 1: Exponent: FALSE
 Sign: FALSE
 MinLen: USINT#16
 DecPlace: USINT#10

Here, no sign column is specified for a negative number, so a minus sign (-) is added to the front of the integer part.

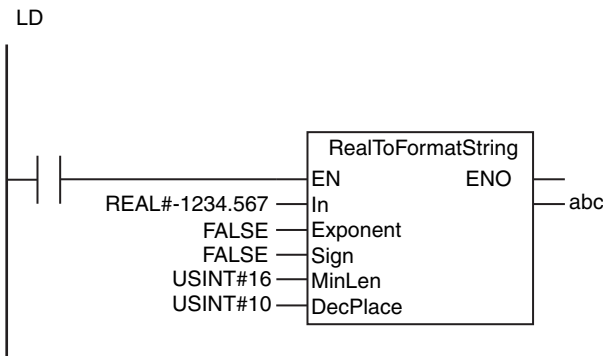

ST

```

abc:=RealToFormatString(REAL#-1234.567, FALSE,
FALSE, USINT#16,
USINT#10);
    
```

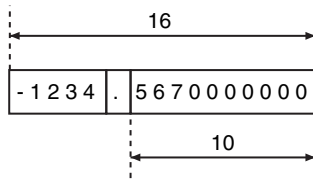

Example 2: Exponent: TRUE
 Sign: FALSE
 MinLen: USINT#21
 DecPlace: USINT#10

Here, the value of *MinLen* exceeds the number of digits in the text string, so the text string is right-aligned and blank characters are added before it.

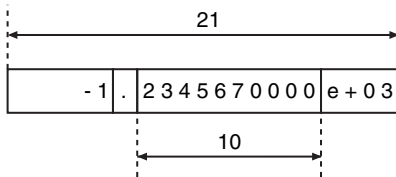

Example 3: Exponent: TRUE
 Sign: TRUE
 MinLen: USINT#22
 DecPlace: USINT#10

The sign column is always on the left. Blank characters are added to the front of the integer part.

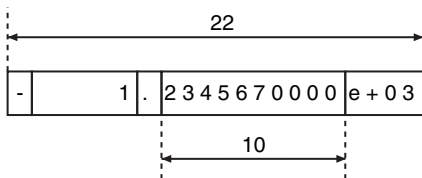

Example 4: Exponent: TRUE
 Sign: TRUE
 MinLen: USINT#12
 DecPlace: USINT#3

The fourth decimal place is rounded off because *DecPlace* is USINT#3.

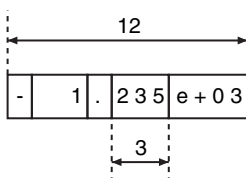

Example 5: Exponent: TRUE
 Sign: TRUE
 MinLen: USINT#12
 DecPlace: USINT#0

The first decimal place is rounded off because *DecPlace* is USINT#0. The decimal point is also not given.

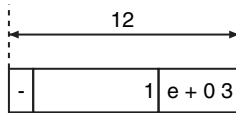

Example 6: Exponent: FALSE
 Sign: TRUE
 MinLen: USINT#8
 DecPlace: USINT#0

Here, no exponent is given and the integer part is only four digits. The first decimal place is rounded off.

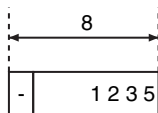

Example 7: Exponent: FALSE
 Sign: TRUE
 MinLen: USINT#2
 DecPlace: USINT#0

Here, the number of digits in the integer part of *In* (four digits) is larger than the value of *MinLen* (USINT#2). The four digits of the integer part are given.

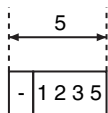

The following examples show the relationships between the values of the input variables and the value of *Out* when *In* is REAL#123456.7.

Example 8: Exponent: FALSE
 Sign: TRUE
 MinLen: USINT#4
 DecPlace: USINT#0

Here, the number of digits in the integer part of *In* (six digits) is larger than the value of *MinLen* (USINT#4). The six digits of the integer part are given. The value of *In* is positive, so the highest digit is placed in the sign column.

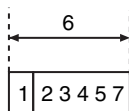

If the value of *In* is infinity, or nonnumeric data, the value of *Out* is as shown below.

Value of <i>In</i>	Value of <i>Out</i>
$+\infty$	'inf'
$-\infty$	'-inf'
Nonnumeric data	'nan' or '-nan'

The following table shows how values are rounded.

Value of fractional part	Treatment	Examples
Less than 0.5	The fractional part is truncated.	1.49 → 1
0.5	If the ones digit is an even number, the fractional part is truncated. If it is an odd number, the value is rounded up.	1.50 → 2 2.50 → 2
Greater than 0.5	The fractional part is rounded up.	1.51 → 2

Additional Information

- *Exponent*, *Sign*, *MinLen*, and *DecPlace* can be omitted. The defaults are applied for any omitted input variables.
- To convert a LREAL variable to a text string, use the `LrealToFormatString` instruction (page 2-294).
- To convert a text string to a real number, use a `STRING_TO_**` (Text String-to-Real Number Conversion Group) instruction (page 2-303).

Precautions for Correct Use

An error occurs in the following cases. *ENO* will be FALSE, and *Out* will not change.

- The value of *DecPlace* is outside of the valid range.
- The value of *DecPlace* is greater than the value of *MinLen*.

LrealToFormatString

The LrealToFormatString instruction converts a LREAL variable to a text string with the specified format.

Instruction	Name	FB/FUN	Graphic expression	ST expression
LrealToFormatString	LREAL-to-Formatted Text String	FUN	<pre> graph LR subgraph LrealToFormatString EN --- In --- Exponent --- Sign --- MinLen --- DecPlace end In --- Out Exponent --- Out Sign --- Out MinLen --- Out DecPlace --- Out </pre>	Out:=LrealToFormatString (In, Exponent, Sign, MinLen, DecPlace);

Variables

Name	Meaning	I/O	Description	Valid range	Unit	Default
In	Data to convert	Input	Data to convert	Depends on data type.	---	0.0
Exponent	Exponent		TRUE: Exponent FALSE: No exponent			FALSE
Sign	Sign column		TRUE: Sign column FALSE: No sign column			
MinLen	Minimum number of digits		Minimum number of digits in <i>Out</i>			6
DecPlace	Precision		Number of decimal digits in <i>Out</i>			0 to 15
Out	Conversion result	Output	Conversion result	327 bytes max. (326 single-byte alphanumeric characters plus the final NULL character)	---	---

	Boolean	Bit strings					Integers							Real numbers		Times, durations, dates, and text strings				
	BOOL	BYTE	WORD	DWORD	LWORD	USINT	UINT	UDINT	ULINT	SINT	INT	DINT	LINT	REAL	LREAL	TIME	DATE	TOD	DT	STRING
In														OK						
Exponent	OK																			
Sign	OK																			
MinLen						OK														
DecPlace						OK														
Out																				OK

Function

The `LRealToFormatString` instruction converts LREAL variable *In* to a text string. *In* is expressed as an alphanumeric text string and output to conversion result *Out*. A NULL character (16#00) is placed at the end of *Out*.

If *In* contains a negative value, a minus sign (–) is added to the front of the text string. If *In* contains a positive value, a plus sign (+) is not added to the front of the text string.

The format of *Out* is determined by exponent *Exponent*, sign column *Sign*, minimum number of digits *MinLen*, and precision *DecPlace*.

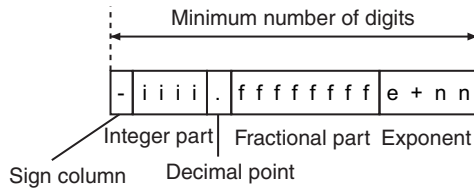

Input variable	Description
Exponent	<i>Exp</i> specifies whether an exponent is given. TRUE: Exponent FALSE: No exponent
Sign	<i>Sign</i> specifies whether there is a sign column. TRUE: Sign column FALSE: No sign column The sign column is used only for a minus sign (–). If the number is positive when the sign column is specified, the sign column will contain a blank character. If the number is negative when no sign column is specified, a minus sign (–) will be added to the front of the integer part. However, if the number of digits in the conversion result exceeds the value of <i>MinLen</i> and the conversion result is positive, the highest digit is placed in the sign column.
MinLen	<i>MinLen</i> is the minimum number of total digits for the sign column, integer part, decimal point, fractional part, and exponent. If the conversion result has fewer digits than the value of <i>MinLen</i> , the text string will be right-aligned (except for the sign column) and remaining digits will contain blank characters. If the number of digits in the conversion result exceeds the value of <i>MinLen</i> , the text string is left-aligned and the text string for the digits that exceed the value of <i>MinLen</i> is assigned to <i>Out</i> .
DecPlace	<i>DecPlace</i> is the number of digits in the fractional part. If the number of digits exceeds the value of <i>DecPlace</i> , the extra digits in the fractional portion are rounded off as described below. If the value of <i>DecPlace</i> is 0, the fractional part and decimal point are not given.

The following examples show the relationships between the values of the input variables and the value of *Out* when *In* is LREAL#–1234.56789.

Example 1: Exponent: FALSE
Sign: FALSE
MinLen: USINT#16
DecPlace: USINT#10

Here, no sign column is specified for a negative number, so a minus sign (–) is added to the front of the integer part.

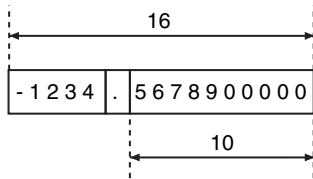
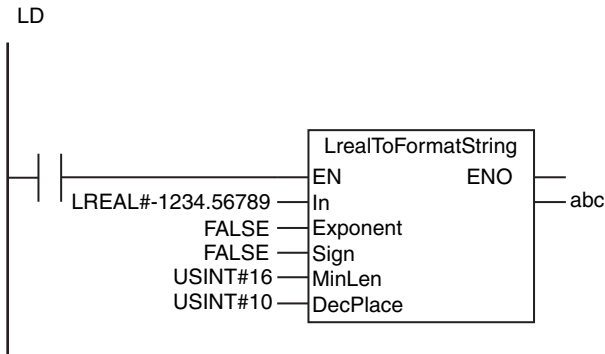

Example 2: Exponent: TRUE
Sign: FALSE
MinLen: USINT#21
DecPlace: USINT#10

Here, the value of *MinLen* exceeds the number of digits in the text string, so the text string is right-aligned and blank characters are added before it.

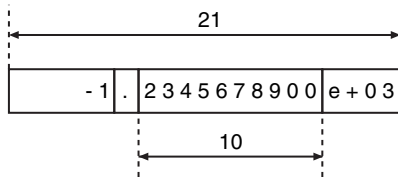

Example 3: Exponent: TRUE
Sign: TRUE
MinLen: USINT#22
DecPlace: USINT#10

The sign column is always on the left. Blank characters are added to the front of the integer part.

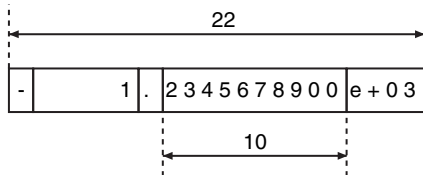

Example 4: Exponent: TRUE
Sign: TRUE
MinLen: USINT#12
DecPlace: USINT#3

The fourth decimal place is rounded off because *DecPlace* is USINT#3.

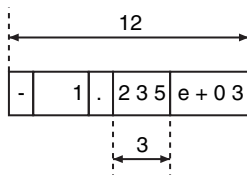

Example 5: Exponent: TRUE
 Sign: TRUE
 MinLen: USINT#12
 DecPlace: USINT#0

The first decimal place is rounded off because *DecPlace* is USINT#0. The decimal point is also not given.

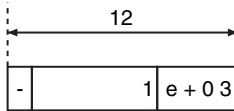

Example 6: Exponent: FALSE
 Sign: TRUE
 MinLen: USINT#8
 DecPlace: USINT#0

Here, no exponent is given and the integer part is only four digits. The first decimal place is rounded off.

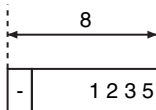

Example 7: Exponent: FALSE
 Sign: TRUE
 MinLen: USINT#2
 DecPlace: USINT#0

Here, the number of digits in the integer part of *In* (four digits) is larger than the value of *MinLen* (USINT#2). The four digits of the integer part are given.

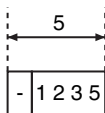

The following examples show the relationships between the values of the input variables and the value of *Out* when *In* is LREAL#123456.789.

Example 8: Exponent: FALSE
 Sign: TRUE
 MinLen: USINT#4
 DecPlace: USINT#0

Here, the number of digits in the integer part of *In* (six digits) is larger than the value of *MinLen* (USINT#4). The six digits of the integer part are given. The value of *In* is positive, so the highest digit is placed in the sign column.

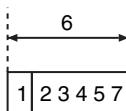

If the value of *In* is infinity, or nonnumeric data, the value of *Out* is as shown below.

Value of <i>In</i>	Value of <i>Out</i>
$+\infty$	'inf'
$-\infty$	'-inf'
Nonnumeric data	'nan' or '-nan'

The following table shows how values are rounded.

Value of fractional part	Treatment	Examples
Less than 0.5	The fractional part is truncated.	1.49 → 1
0.5	If the ones digit is an even number, the fractional part is truncated. If it is an odd number, the value is rounded up.	1.50 → 2 2.50 → 2
Greater than 0.5	The fractional part is rounded up.	1.51 → 2

Additional Information

- *Exponent*, *Sign*, *MinLen*, and *DecPlace* can be omitted. The defaults are applied for any omitted input variables.
- To convert a REAL variable to a text string, use the `RealToFormatString` instruction (page 2-289).
- To convert a text string to a real number, use a `STRING_TO_**` (Text String-to-Real Number Conversion Group) instruction (page 2-303).

Precautions for Correct Use

An error occurs in the following cases. *ENO* will be FALSE, and *Out* will not change.

- The value of *DecPlace* is outside of the valid range.
- The value of *DecPlace* is greater than the value of *MinLen*.

STRING_TO_** (Text String-to-Integer Conversion Group)

These instructions convert text strings to integers.

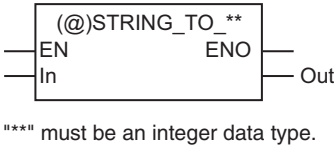
Instruction	Name	FB/FUN	Graphic expression	ST expression
STRING_TO_**	Text String-to-Integer Conversion Group	FUN		Out:=STRING_TO_** (In); *** must be an integer data type.

Variables

Name	Meaning	I/O	Description	Valid range	Unit	Default
In	Data to convert	Input	Data to convert	*	---	"
Out	Conversion result	Output	Conversion result	Depends on data type.	---	---

* The valid range depends on the data type of *Out*. Refer to *Function* for details.

	Boolean	Bit strings				Integers							Real numbers	Times, durations, dates, and text strings							
		BOOL	BYTE	WORD	DWORD	LWORD	USINT	UINT	UDINT	ULINT	SINT	INT		DINT	LINT	REAL	LREAL	TIME	DATE	TOD	DT
In																					OK
Out						OK	OK	OK	OK	OK	OK	OK									

Function

These instructions convert a text string, *In*, to an integer.

Basically, the text string in *In* must consist only of numbers 0 to 9. The following exceptions are possible.

- If the first character in *In* is a single minus sign (–) or a single plus sign (+), it is processed as the sign.
- Any blank characters at the beginning of *In* are ignored.
- Any blank characters between an initial minus sign (–) or plus sign (+) and a number are ignored.
- Any single underbars ('_') at any location are ignored.
- An error occurs if there are two or more consecutive underbars ('_') at any location.
- An error occurs if there are any underbars ('_') at the beginning or end.
- An error occurs if there are any underbars ('_') between the minus signs (–) or plus sign (+) and the number at the beginning.

The name of the instruction is determined by the data type of conversion result *Out*. For example, if *Out* is the DINT data type, the instruction is STRING_TO_DINT.

The following example for the STRING_TO_DINT instruction is for when *In* is '123456789'.

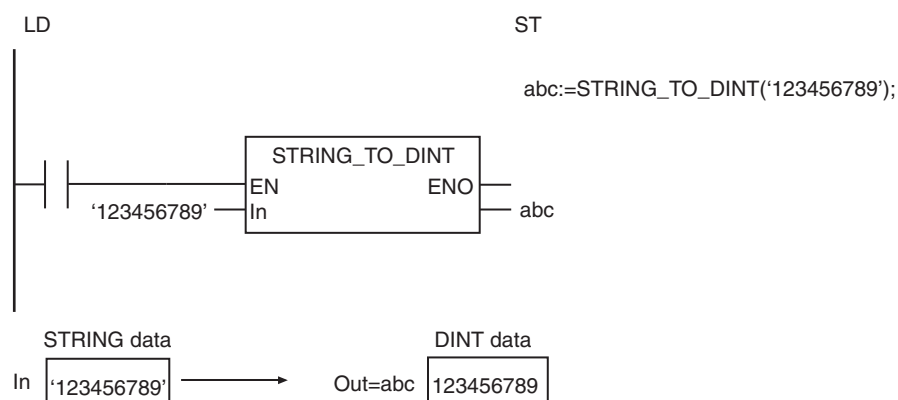

The valid range of *In* depends on the data type of *Out* as shown below:

Data type of <i>Out</i>	Valid range of <i>In</i> (maximum number of bytes)*
USINT	4 bytes (three single-byte alphanumeric characters plus the final NULL character)
UINT	6 bytes (five single-byte alphanumeric characters plus the final NULL character)
UDINT	11 bytes (10 single-byte alphanumeric characters plus the final NULL character)
ULINT	21 bytes (20 single-byte alphanumeric characters plus the final NULL character)
SINT	5 bytes (four single-byte alphanumeric characters plus the final NULL character)
INT	7 bytes (six single-byte alphanumeric characters plus the final NULL character)
DINT	12 bytes (11 single-byte alphanumeric characters plus the final NULL character)
LINT	21 bytes (20 single-byte alphanumeric characters plus the final NULL character)

* Any blank characters (' ') at the beginning of the text string, any zeros at the beginning of the text string, and any underbars ('_') in the text string are not included in the number of bytes.

Additional Information

- To convert a text string to a hexadecimal number, use a STRING_TO_** (Text String-to-Bit String Conversion Group) instruction (page 2-301).
- To convert an integer to a text string, use a **_TO_STRING (Integer-to-Text String Conversion Group) instruction (page 2-283).

Precautions for Correct Use

- Always use the correct instruction name for the data type of *Out*.
- If the value of *In* is '-0', the value of *Out* is 0.
- An error occurs in the following cases. *ENO* will be FALSE, and *Out* will not change.
 - The text string in *In* does not express a number.
 - The conversion result exceeds the valid range of the data type of *Out*.

STRING_TO_** (Text String-to-Bit String Conversion Group)

These instructions convert text strings to bit strings.

Instruction	Name	FB/FUN	Graphic expression	ST expression
STRING_TO_**	Text String-to-Bit String Conversion Group	FUN	<p>*** must be a bit string data type.</p>	Out:=STRING_TO_** (In); *** must be a bit string data type.

Variables

Name	Meaning	I/O	Description	Valid range	Unit	Default
In	Data to convert	Input	Data to convert	*	---	"
Out	Conversion result	Output	Conversion result	Depends on data type.	---	---

* The valid range depends on the data type of *Out*. Refer to *Function* for details.

	Boolean	Bit strings				Integers							Real numbers	Times, durations, dates, and text strings						
	BOOL	BYTE	WORD	DWORD	LWORD	USINT	UINT	UDINT	ULINT	SINT	INT	DINT	LINT	REAL	LREAL	TIME	DATE	TOD	DT	STRING
In																				OK
Out		OK	OK	OK	OK															

Function

These instructions interpret the content of a text string, *In*, as a hexadecimal number and convert it to a bit string.

Basically, the text string in *In* must consist only of '0' to '9', 'a' to 'f', and 'A' to 'F'. The following exception is possible.

- Any continuous blank characters or zeros at the beginning of *In* are ignored.
- Any single underbars ('_') at any location are ignored.
- An error occurs if there are two or more consecutive underbars ('_') at any location.
- An error occurs if there are any underbars ('_') at the beginning or end.
- An error occurs if there are any underbars ('_') between the minus signs ('-') or plus sign ('+') and the number at the beginning.

The name of the instruction is determined by the data type of conversion result *Out*. For example, if *Out* is the BYTE data type, the instruction is STRING_TO_BYTE.

The following example for the STRING_TO_BYTE instruction is for when *In* is ' AB'. Any blank characters at the beginning are ignored.

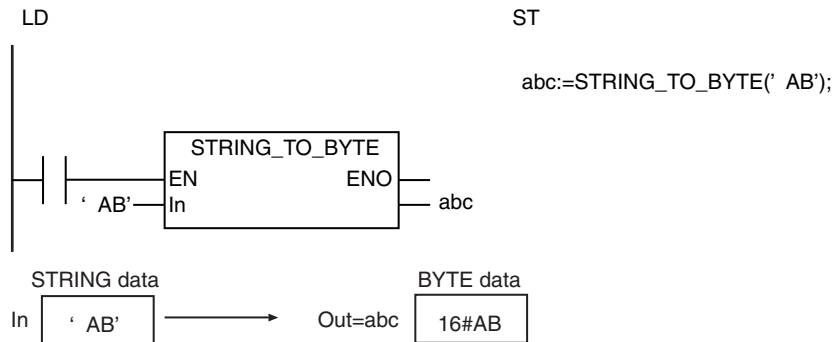

The valid range of *In* depends on the data type of *Out* as shown below:

Data type of <i>Out</i>	Valid range of <i>In</i> (maximum number of bytes)*
BYTE	3 bytes (two single-byte alphanumeric characters plus the final NULL character)
WORD	5 bytes (four single-byte alphanumeric characters plus the final NULL character)
DWORD	9 bytes (eight single-byte alphanumeric characters plus the final NULL character)
LWORD	17 bytes (16 single-byte alphanumeric characters plus the final NULL character)

* Any blank characters (' ') at the beginning of the text string, any zeros at the beginning of the text string, and any underbars ('_') in the text string are not included in the number of bytes.

Additional Information

- To treat a signed number as a text string, use a STRING_TO_** (Text String-to-Integer Conversion Group) instruction (page 2-299).
- To convert a bit string to a text string, use a **_TO_STRING (Bit String-to-Text String Conversion Group) instruction (page 2-285).

Precautions for Correct Use

- Always use the correct instruction name for the data type of *Out*.
- An error occurs in the following cases. *ENO* will be FALSE, and *Out* will not change.
 - The text string in *In* does not express a number.
 - The conversion result exceeds the valid range of the data type of *Out*.

STRING_TO_** (Text String-to-Real Number Conversion Group)

These instructions convert text strings to real numbers.

Instruction	Name	FB/FUN	Graphic expression	ST expression
STRING_TO_**	Text String-to-Real Number Conversion Group	FUN	<p>**** must be a real number data type.</p>	Out:=STRING_TO_** (In); **** must be a real number data type.

Variables

Name	Meaning	I/O	Description	Valid range	Unit	Default
In	Data to convert	Input	Data to convert	311 bytes max. (310 single-byte alphanumeric characters plus the final NULL character)	---	"
Out	Conversion result	Output	Conversion result	Depends on data type.	---	---

	Boolean	Bit strings				Integers							Real numbers	Times, durations, dates, and text strings						
	BOOL	BYTE	WORD	DWORD	LWORD	USINT	UINT	UDINT	ULINT	SINT	INT	DINT	LINT	REAL	LREAL	TIME	DATE	TOD	DT	STRING
In																				OK
Out														OK	OK					

Function

These instructions convert a text string, *In*, to a real number.

The name of the instruction is determined by the data type of conversion result *Out*. For example, if *Out* is the LREAL data type, the instruction is STRING_TO_LREAL.

The format of the text sting in *In* is given below.

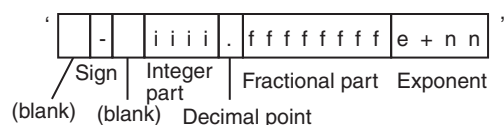

Name	Format
Sign	<ul style="list-style-type: none"> Any consecutive blank characters at the beginning of the text string are ignored. Any following single plus or minus sign is treated as the sign. The plus sign can be omitted. Any consecutive blank characters after the sign are ignored.
Integer part	<ul style="list-style-type: none"> The characters after the sign and up to the decimal point are taken as the integer part. Any consecutive blank characters after the sign are not included in the integer part. The sign may sometimes be omitted. If the decimal point and fractional part are omitted, the characters up to the exponent are taken as the integer part. If the decimal point, fractional part, and exponent are omitted, the characters up to the end of the text string are taken as the integer part. The integer part consists of '0' to '9'. The integer part cannot be omitted. The maximum number of digits in the integer part is the maximum text string length of 1985 minus the total number of bytes in the following: the sign, decimal point, fractional part, exponent, and blank characters before and after the sign.
Decimal point	<ul style="list-style-type: none"> A single period ('.') following the integer part is taken as the decimal point. Omit the decimal point if there is no fractional part.
Fractional part	<ul style="list-style-type: none"> The characters after the decimal point and up to the exponent are taken as the fractional part. If the exponent is omitted, the characters up to the end of the text string are taken as the fractional part. The fractional part consists of '0' to '9'. The fractional part can be omitted. The fractional part can consist of a maximum of 15 digits. If there is no decimal point, then there is no fractional part.
Exponent	<ul style="list-style-type: none"> The exponent consists of a single 'e' or 'E' after the fractional part, a following single plus or minus sign, and the remaining characters to the end of the text string. If there is no fractional part, then the above text string after the decimal point is taken as the exponent. If there is no decimal point or fractional part, then the above text string after the integer part is taken as the exponent. The numeric part of the exponent consists of '0' to '9'. The exponent can be omitted. The numeric part of the exponent can consist of a maximum of three digits.

Example 1: The following example uses the sign, decimal point, and fractional part, but does not use an exponent.

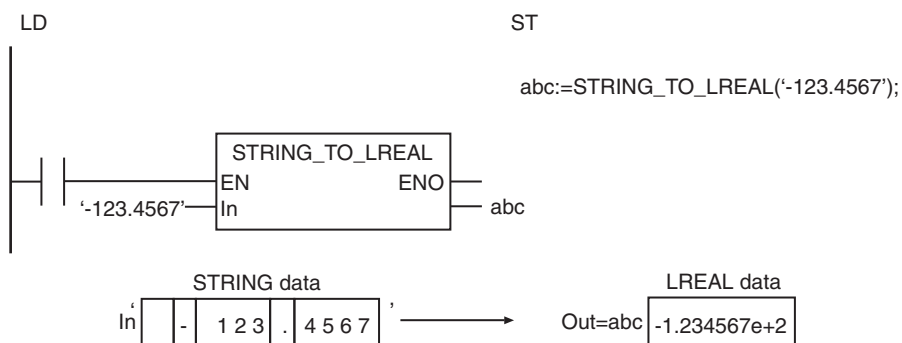

Example 2: The following example uses the sign, decimal point, fractional part, and exponent.

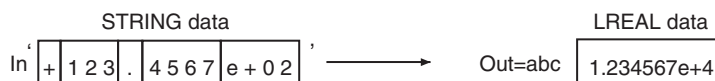

Example 3: The following example does not use the sign, but uses the decimal point, fractional part, and exponent.

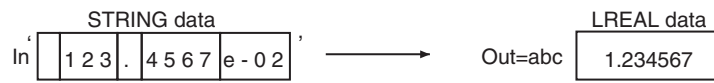

Example 4: The following example does not use the sign, fractional part, decimal point, and exponent.

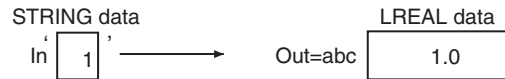

If the value of *In* is '+inf', the value of *Out* is positive infinity. If the value of *In* is '-inf', the value of *Out* is negative infinity. In either case, characters are not case sensitive.

Additional Information

To convert a real number to a text string, use a ****_TO_STRING** (Real Number-to-Text String Conversion Group) instruction (page 2-287).

Precautions for Correct Use

- Always use the correct instruction name for the data type of *Out*.
- Any single underbars ('_') at any location in *In* are ignored.
- An error occurs if there are any underbars ('_') at the beginning or end of *In*.
- An error occurs if there are two or more consecutive underbars ('_') at any location in *In*.
- An error occurs if there are any underbars ('_') between the minus signs ('-') or plus sign ('+') and the number at the beginning of *In*.
- If the content of *In* exceeds the precision of the data type of *Out*, the value is rounded.
- If the content of *In* is closer to 0 than the minimum value of the data type of *Out*, the value of *Out* will be 0.
- If the content of *In* exceeds the valid range of *Out*, *Out* will be positive infinity for a positive number or negative infinity for a negative number.
- An error occurs in the following cases. *ENO* will be FALSE, and *Out* will not change.
 - The text string in *In* does not express a number.
 - The text string in *In* has a decimal point but not a fractional part.

- Conversion is performed to within the effective digits of the data type of *In*. If *In* is a real number, the fractional part is rounded off to the closest integer. The following table shows how values are rounded.

Value of fractional part	Treatment	Examples
Less than 0.5	The fractional part is truncated.	1.49 → 1
0.5	If the ones digit is an even number, the fractional part is truncated. If it is an odd number, the value is rounded up.	1.50 → 2 2.50 → 2
Greater than 0.5	The fractional part is rounded up.	1.51 → 2

The valid ranges for *In* and *Out* depend on their data types. Refer to the descriptions of the functions of the following instructions for the valid ranges: ****_TO_**** (Integer-to-Integer Conversion Group) (page 2-262), ****_TO_**** (Bit String-to-Integer Conversion Group) (page 2-270), and ****_TO_**** (Real Number-to-Integer Conversion Group) (page 2-276).

For detailed specifications when *In* is STRING data, refer to Function for the **STRING_TO_**** (Text String-to-Integer Conversion Group) instructions (page 2-299).

Precautions for Correct Use

- Always use the correct instruction name for the data type of *Out*.
- If the data type of *In* is for a bit string and the sizes of the data types of *In* and *Out* are different, the following processing is performed.
 - If the data size of *Out* is larger than the data size of *In*, the upper digits of *Out* will contain 0.
 - If the data size of *Out* is smaller than the data size of *In*, the upper digits are truncated in *Out*.
- Observe the following precautions if *In* is STRING data.
 - If the first character in *In* is a minus sign (–) or a plus sign (+), it is processed as the sign.
 - Except for a minus sign (–) or a plus sign (+) at the beginning, *In* must consist of consecutive '0' to '9' characters. Underbars ('_') and blank characters before or after the '–' or '+' are allowed in the text string.
- If the conversion result exceeds the valid range of *Out*, *Out* will contain an undefined value. Always make sure that the value of *In* is within the valid range so that the conversion result will not exceed the valid range of *Out*.
- An error occurs in the following cases. *ENO* will be FALSE, and *Out* will not change.
 - *In* is STRING data, but the text sting in *In* does not express a number.

TO_** (Bit String Conversion Group)

These instructions convert integers, bit strings, real numbers, and text strings to bit strings.

Instruction	Name	FB/FUN	Graphic expression	ST expression
TO_**	Bit String Conversion Group	FUN	<p>*** must be a bit string data type.</p>	Out:=TO_**(In); *** must be a bit string data type.

Variables

Name	Meaning	I/O	Description	Valid range	Unit	Default
In	Data to convert	Input	Data to convert	*1	---	*2
Out	Conversion result	Output	Conversion result	*1	---	---

*1 The valid ranges depend on the data types of *In* and *Out*.

*2 If you omit the input parameter, the default value is not applied. A building error will occur.

	Boolean	Bit strings					Integers							Real numbers		Times, durations, dates, and text strings					
		BOOL	BYTE	WORD	DWORD	LWORD	USINT	UINT	UDINT	ULINT	SINT	INT	DINT	LINT	REAL	LREAL	TIME	DATE	TOD	DT	STRING
In		OK	OK	OK	OK	OK	OK	OK	OK	OK	OK	OK	OK	OK	OK						OK
Out		OK	OK	OK	OK																

Function

These instructions convert the integer, bit string, real number, or text string in *In* to a bit string.

The name of the instruction is determined by the data type of conversion result *Out*. For example, if *Out* is the WORD data type, the instruction is TO_WORD.

The following example for the TO_WORD instruction is for when *In* is INT#-1234.

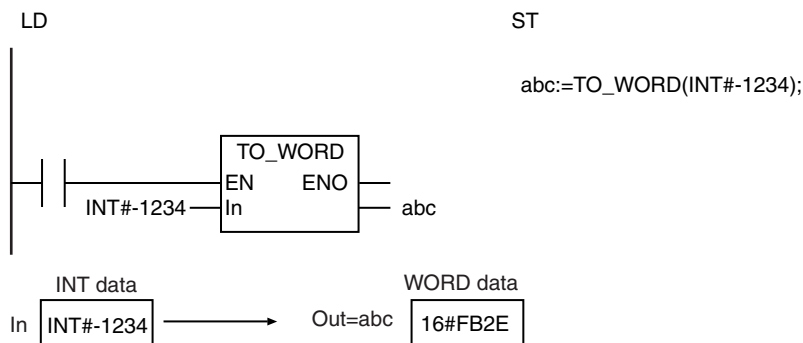

The valid ranges for *In* and *Out* depend on their data types. Refer to the descriptions of the functions of the following instructions for the valid ranges: ****_TO_***** (Integer-to-Bit String Conversion Group) (page 2-265), ****_TO_***** (Bit String-to-Bit String Conversion Group) (page 2-272), and ****_TO_***** (Real Number-to-Bit String Conversion Group) (page 2-279).

For detailed specifications when *In* is STRING data, refer to Function for the **STRING_TO_**** (Text String-to-Bit String Conversion Group) instructions (page 2-301).

Precautions for Correct Use

- Always use the correct instruction name for the data type of *Out*.
- If the conversion result exceeds the valid range of *Out*, *Out* will contain an undefined value. Always make sure that the value of *In* is within the valid range so that the conversion result will not exceed the valid range of *Out*.
- An error occurs in the following cases. *ENO* will be FALSE, and *Out* will not change.
 - *In* is STRING data, but the text sting in *In* does not express a number.

TO_** (Real Number Conversion Group)

These instructions convert integers, bit strings, real numbers, and text strings to real numbers.

Instruction	Name	FB/FUN	Graphic expression	ST expression
TO_**	Real Number Conversion Group	FUN	<p>*** must be a real number data type.</p>	Out:=TO_**(In); *** must be a real number data type.

Variables

Name	Meaning	I/O	Description	Valid range	Unit	Default
In	Data to convert	Input	Data to convert	*1, *2	---	*3
Out	Conversion result	Output	Conversion result	*1	---	---

*1 The valid ranges depend on the data types of *In* and *Out*.

*2 For STRING data, the valid range is 311 bytes max. (310 single-byte alphanumeric characters plus the final NULL character).

*3 If you omit the input parameter, the default value is not applied. A building error will occur.

	Boolean	Bit strings					Integers							Real numbers		Times, durations, dates, and text strings				
	BOOL	BYTE	WORD	DWORD	LWORD	USINT	UINT	UDINT	ULINT	SINT	INT	DINT	LINT	REAL	LREAL	TIME	DATE	TOD	DT	STRING
In		OK	OK	OK	OK	OK	OK	OK	OK	OK	OK	OK	OK	OK	OK					OK
Out														OK	OK					

Function

These instructions convert the integer, bit string, real number, or text string in *In* to a real number.

The name of the instruction is determined by the data type of conversion result *Out*. For example, if *Out* is the REAL data type, the instruction is TO_REAL. If the value of *In* is positive or negative infinity, the value of *Out* is positive or negative infinity.

The following example for the TO_REAL instruction is for when *In* is INT#1234.

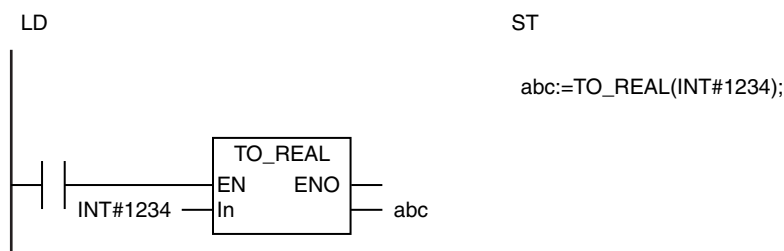

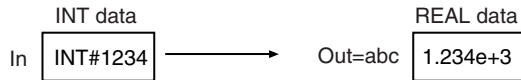

The valid ranges for *In* and *Out* depend on their data types. Refer to the descriptions of the functions of the following instructions for the valid ranges: ****_TO_**** (Integer-to-Real Number Conversion Group) (page 2-268), ****_TO_**** (Bit String-to-Real Number Conversion Group) (page 2-274), and ****_TO_**** (Real Number-to-Real Number Conversion Group) (page 2-281).

For detailed specifications when *In* is STRING data, refer to Function for the **STRING_TO_**** (Text String-to-Real Number Conversion Group) instructions (page 2-303).

Precautions for Correct Use

- Always use the correct instruction name for the data type of *Out*.
- An error occurs in the following cases. *ENO* will be FALSE, and *Out* will not change.
 - *In* is STRING data, but the text sting in *In* does not express a number.

EnumToNum

The EnumToNum instruction converts enumeration data to DINT data.

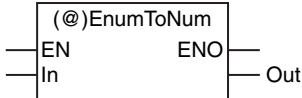
Instruction	Name	FB/FUN	Graphic expression	ST expression
EnumToNum	Enumeration-to-Integer	FUN		Out:=EnumToNum(In);

Variables

Name	Meaning	I/O	Description	Valid range	Unit	Default
In	Data to convert	Input	Data to convert	---	---	0
Out	Conversion result	Output	Conversion result	Depends on data type.	---	---

	Boolean	Bit strings					Integers							Real numbers	Times, durations, dates, and text strings						
	BOOL	BYTE	WORD	DWORD	LWORD	USINT	UINT	UDINT	ULINT	SINT	INT	DINT	LINT	REAL	LREAL	TIME	DATE	TOD	DT	STRING	
In																					Enumeration
Out																					OK

Function

The EnumToNum instruction converts the value of data to convert *In*, which is an enumeration, to a DINT value and outputs the value to conversion result *Out*.

Use this instruction, for example, to monitor the value of an enumerated variable on an HMI or other display device that does not handle enumerated variables.

The following example shows how to convert enumerator *red* of the enumeration *Color* to a value and output that value to DINT variable *Output*. If the value of enumerator *red* is 0, *Output* will be DINT#0.

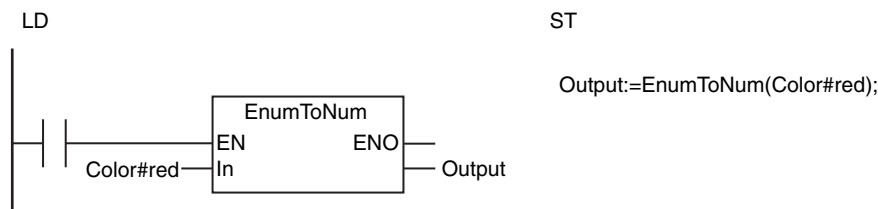

Precautions for Correct Use

Version Information

A CPU Unit with unit version 1.02 or later and Sysmac Studio version 1.03 or higher are required to use this instruction.

Sample Programming

In this sample, the operating mode of the user program is defined with enumerated data type EnumMode. To monitor the operating mode on the HMI, the value of variable *myEnumMode* (an enumeration with a data type of EnumMode) is converted and the converted value is output to DINT variable *Monitor_myMode*. For example, if the value of *myEnumMode* is mode2, the value of *Monitor_myMode* will be 2.

Data Type Definition

Name	Enumeration value	Comment
EnumMode	---	Enumerated data type
mode0	0	Member
mode1	1	Member
mode2	2	Member

LD

Name	Data type	Default	Comment
myEnumMode	EnumMode	mode0	Value of mode in enumerated data type
Monitor_myMode	DINT	0	Monitored mode value

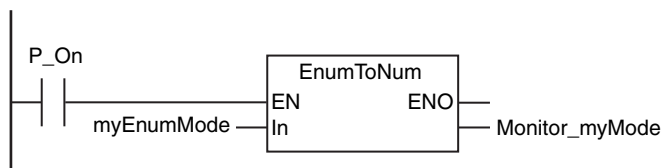

ST

Name	Data type	Default	Comment
myEnumMode	EnumMode	mode0	Value of mode in enumerated data type
Monitor_myMode	DINT	0	Monitored mode value

```
Monitor_myMode:=EnumToNum(myEnumMode);
```

NumToEnum

The NumToEnum instruction converts DINT data to enumeration data.

Instruction	Name	FB/FUN	Graphic expression	ST expression
NumToEnum	Integer-to-Enumeration	FUN		NumToEnum(In,InOut);

Variables

Name	Meaning	I/O	Description	Valid range	Unit	Default
In	Data to convert	Input	Data to convert	Depends on data type.	---	0
InOut	Conversion result	In-out	Conversion result	---	---	---
Out	Return value	Output	TRUE: Instruction was executed normally. FALSE: Instruction was not executed or an error occurred.	Depends on data type.	---	---

	Boolean	Bit strings					Integers							Real numbers	Times, durations, dates, and text strings						
	BOOL	BYTE	WORD	DWORD	LWORD	USINT	UINT	UDINT	ULINT	SINT	INT	DINT	LINT	REAL	LREAL	TIME	DATE	TOD	DT	STRING	
In												OK									
InOut		Enumeration																			
Out	OK																				

Function

The NumToEnum instruction converts the value of data to convert *In*, which is DINT data, to an enumeration value and outputs that value to conversion result *InOut*.

Use this instruction, for example, to change the value of an enumerated variable from an HMI or other display device that does not handle enumerated variables.

The following example shows how to convert the value of DINT variable *In1* and output the results to variable *ColorA*, which has an enumerated data type of *Color*. If *green* is the enumerator that corresponds to an enumeration value of 1 for *Color* and the value of *In1* is 1, the value of *ColorA* will be *green*.

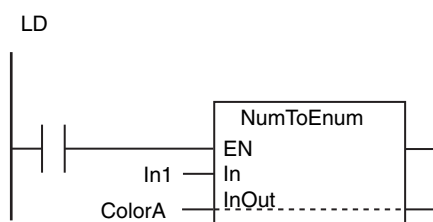

```
ST
    NumToEnum(In1,ColorA);
```

Additional Information

If you use this instruction in a ladder diagram, you can use *Out* to see if the value of *In* is within the range of values for *InOut*.

Precautions for Correct Use

An error occurs if the value of *In* is not within the range of values for *InOut*. *Out* will be FALSE, and the value of *InOut* will not change.



Version Information

A CPU Unit with unit version 1.02 or later and Sysmac Studio version 1.03 or higher are required to use this instruction.

Sample Programming

In this sample, the operating mode of the user program is defined with enumerated data type EnumMode. To change the operating mode from an HMI, the value of *Input_myMode*, which is a DINT variable, is written. In the user program, the value of *Input_myMode* is converted and the converted value is output to variable *myEnumMode* (an enumeration with a data type of EnumMode). For example, if the value of *Input_myMode* is 1, the value of *myEnumMode* will be mode1.

● Data Type Definition

Name	Enumeration value	Comment
EnumMode	---	Enumerated data type
mode0	0	Member
mode1	1	Member
mode2	2	Member

LD

Name	Data type	Default	Comment
myEnumMode	EnumMode	mode0	Value of mode in enumerated data type
Input_myMode	DINT	0	Value of mode to which to change

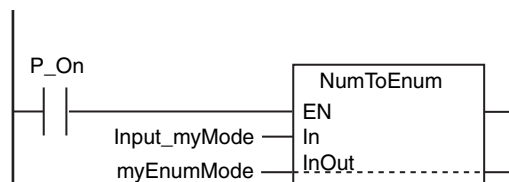

ST

Name	Data type	Default	Comment
myEnumMode	EnumMode	mode0	Value of mode in enumerated data type
Input_myMode	DINT	0	Value of mode to which to change

```
NumToEnum(Input_myMode, myEnumMode);
```

TRUNC, Round, and RoundUp

These instructions change real numbers to integers.

TRUNC: Truncates the number at the first decimal digit.

Round: Rounds the number at the first decimal digit.

RoundUp: Rounds up the number at the first decimal digit.

Instruction	Name	FB/FUN	Graphic expression	ST expression
TRUNC	Truncate	FUN		Out:=TRUNC(In);
Round	Round Off Real Number	FUN		Out:=Round(In);
RoundUp	Round Up Real Number	FUN		Out:=RoundUp(In);

Variables

Name	Meaning	I/O	Description	Valid range	Unit	Default
In	Data to convert	Input	Data to convert	Depends on data type.	---	*
Out	Conversion result	Output	Conversion result	Depends on data type.	---	---

* If you omit the input parameter, the default value is not applied. A building error will occur.

	Boolean	Bit strings					Integers							Real numbers		Times, durations, dates, and text strings				
	BOOL	BYTE	WORD	DWORD	LWORD	USINT	UINT	UDINT	ULINT	SINT	INT	DINT	LINT	REAL	LREAL	TIME	DATE	TOD	DT	STRING
In														OK	OK					
Out												OK	OK							

Function

These instructions change the real number in *In* to an integer by eliminating the fractional part.

● TRUNC

The TRUNC instruction truncates the number at the first decimal digit.

● Round

The Round instruction rounds the number at the first decimal digit. The following table shows how values are rounded.

Value of fractional part	Treatment	Examples
Less than 0.5	The fractional part is truncated.	1.49 → 1 -1.49 → -1
0.5	If the ones digit is an even number, the fractional part is truncated. If it is an odd number, the value is rounded up.	1.50 → 2 2.50 → 2 -1.50 → -2 -2.50 → -2
Greater than 0.5	The fractional part is rounded up.	1.51 → 2 -1.51 → -2

● RoundUp

The RoundUp instruction rounds up the number at the first decimal digit.

The differences in these three instructions are shown by the following examples.

Input value	Output value		
	TRUNC	Round	RoundUp
REAL#1.6	DINT#1	DINT#2	DINT#2
REAL#1.5	DINT#1	DINT#2	DINT#2
REAL#1.5	DINT#1	DINT#1	DINT#2
REAL#2.5	DINT#2	DINT#2	DINT#3
REAL#-1.6	DINT#-1	DINT#-2	DINT#-2
REAL#-1.5	DINT#-1	DINT#-2	DINT#-2
REAL#-1.4	DINT#-1	DINT#-1	DINT#-2
REAL#-2.5	DINT#-2	DINT#-2	DINT#-3

The following example for the TRUNC instruction is for when *In* is REAL#-3.55. The value of variable *abc* will be DINT#-3.

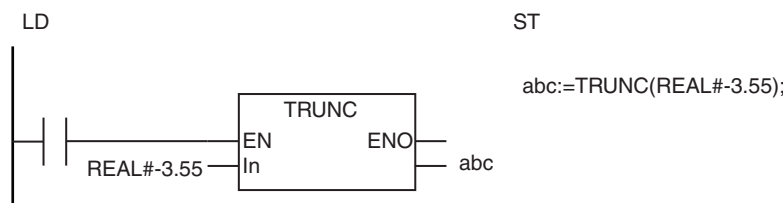

The TRUNC instruction truncates the number at the first decimal digit. The value of *In* is REAL#-3.55, so the value of *abc* will be DINT#-3.

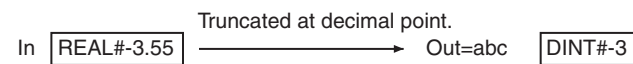

Additional Information

If the data type of *In* is REAL, the data type of *Out* is DINT. If the data type of *In* is LREAL, the data type of *Out* is LINT.

Precautions for Correct Use

If the conversion result exceeds the valid range of *Out*, *Out* will contain an undefined value. Always make sure that the value of *In* is within the valid range so that the conversion result will not exceed the valid range of *Out*.

Bit String Processing Instructions

Instruction	Name	Page
AND (&), OR, and XOR	Logical AND/Logical OR/ Logical Exclusive OR	2-320
XORN	Logical Exclusive NOR	2-323
NOT	Bit Reversal	2-325
AryAnd, AryOr, AryXor, and AryXorN	Array Logical AND/ Array Logical OR/ Array Logical Exclusive OR/ Array Logical Exclusive NOR	2-327

AND (&), OR, and XOR

These instructions perform processing on Boolean variables or individual bits in bit strings.

- AND (&): Logical AND
- OR: Logical OR
- XOR: Logical Exclusive OR

Instruction	Name	FB/FUN	Graphic expression	ST expression
AND (&)	Logical AND	FUN		Out:=In1 AND ..AND InN; Out:=In1 & ..& InN;
OR	Logical OR	FUN		Out:=In1 OR ..OR InN;
XOR	Logical Exclusive OR	FUN		Out:=In1 XOR ..XOR InN;

Variables

Name	Meaning	I/O	Description	Valid range	Unit	Default
In1 to InN	Data to process	Input	Data to process, where N is 2 to 5	Depends on data type.	---	0*
Out	Processing result	Output	Processing result	Depends on data type.	---	---

* If you omit the input parameter that connects to *InN*, the default value is not applied, and a building error will occur. For example, if N is 3 and the input parameters that connect to *In1* and *In2* are omitted, the default values are applied, but if the input parameter that connects to *In3* is omitted, a building error will occur.

	Boolean	Bit strings					Integers							Real numbers	Times, durations, dates, and text strings					
	BOOL	BYTE	WORD	DWORD	LWORD	USINT	UINT	UDINT	ULINT	SINT	INT	DINT	LINT	REAL	LREAL	TIME	DATE	TOD	DT	STRING
In1 to InN	OK	OK	OK	OK	OK															
Out	Must be same data type as <i>In1</i> to <i>InN</i>																			

Function

These instructions perform processing on Boolean variables or corresponding bits in bit strings. The data to process is in *In1* to *InN*. *In1* to *InN* and *Out* must be the same data types.

If there are more than two data to process, processing is performed with the following procedure.

- 1** Processing is performed for *In1* and *In2*.
- 2** Processing is performed for the results of step 1 and *In3*.
- 3** Processing is performed for the results of step 2 and *In4*.
- ⋮
- ⋮

The relationships between input and output variables are given in the following tables.

● AND (&)

If both bits are TRUE, then the processing result is TRUE. Otherwise, the processing result is FALSE.

<i>In1</i> bit	<i>In2</i> bit	<i>Out</i> bit
FALSE	FALSE	FALSE
FALSE	TRUE	FALSE
TRUE	FALSE	FALSE
TRUE	TRUE	TRUE

● OR

If both bits are FALSE, then the processing result is FALSE. Otherwise, the processing result is TRUE.

<i>In1</i> bit	<i>In2</i> bit	<i>Out</i> bit
FALSE	FALSE	FALSE
FALSE	TRUE	TRUE
TRUE	FALSE	TRUE
TRUE	TRUE	TRUE

● XOR

If both bits are the same, then the processing result is FALSE. If one bit is TRUE and the other is FALSE, then the processing result is TRUE.

<i>In1</i> bit	<i>In2</i> bit	<i>Out</i> bit
FALSE	FALSE	FALSE
FALSE	TRUE	TRUE
TRUE	FALSE	TRUE
TRUE	TRUE	FALSE

The following example shows the AND instruction when *In1* is BYTE#16#3A, *In2* is BYTE#16#28 and *In3* is BYTE#16#73.

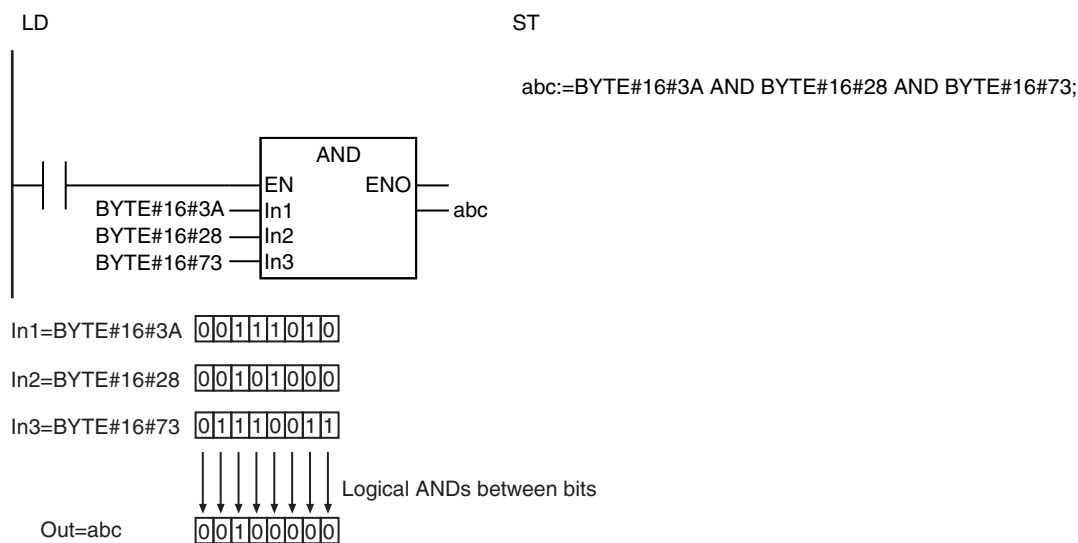

The functions of the AND instruction and the & instruction are exactly the same. Use the form that is easier to use.

Additional Information

In ST, there is no limit to the number of input variables if you use the following notation.

Out:=In1 AND In2 AND In3 AND In4 AND In5 AND In6 ...

Out:=In1 & In2 & In3 & In4 & In5 & In6 ...

Out:=In1 OR In2 OR In3 OR In4 OR In5 OR In6 ...

Out:=In1 XOR In2 XOR In3 XOR In4 XOR In5 XOR In6 ...

Precautions for Correct Use

The data types of *In1* to *InN* and *Out* must all be the same. Otherwise, a building error will occur.

XORN

The XORN instruction performs a logical exclusive NOR operation on Boolean variables or individual bits in bit strings.

Instruction	Name	FB/FUN	Graphic expression	ST expression
XORN	Logical Exclusive NOR	FUN		Out:=In1 XOR NOT .. XOR NOT InN;

Variables

Name	Meaning	I/O	Description	Valid range	Unit	Default
In1 to InN	Data to process	Input	Data to process, where N is 2 to 5	Depends on data type.	---	0*
Out	Processing result	Output	Processing result	Depends on data type.	---	---

* If you omit the input parameter that connects to *InN*, the default value is not applied, and a building error will occur. For example, if N is 3 and the input parameters that connect to *In1* and *In2* are omitted, the default values are applied, but if the input parameter that connects to *In3* is omitted, a building error will occur.

	Boolean	Bit strings				Integers							Real numbers		Times, durations, dates, and text strings					
	BOOL	BYTE	WORD	DWORD	LWORD	USINT	UINT	UDINT	ULINT	SINT	INT	DINT	LINT	REAL	LREAL	TIME	DATE	TOD	DT	STRING
In1 to InN	OK	OK	OK	OK	OK															
Out	Must be same data type as <i>In1</i> to <i>InN</i>																			

Function

The XORN instruction performs processing on Boolean variables or corresponding bits in bit strings. The data to process is in *In1* to *InN*. *In1* to *InN* and *Out* must be the same data types.

If there are more than two data to process, processing is performed with the following procedure.

- 1** Processing is performed for *In1* and *In2*.
- 2** Processing is performed for the results of step 1 and *In3*.
- 3** Processing is performed for the results of step 2 and *In4*.

⋮ ⋮

The relationships between input and output variables are given in the following table. If both values are the same, then the processing result is TRUE. Otherwise, the processing result is FALSE.

<i>In1</i> bit	<i>In2</i> bit	<i>Out</i> bit
FALSE	FALSE	TRUE
FALSE	TRUE	FALSE
TRUE	FALSE	FALSE
TRUE	TRUE	TRUE

The following example is for when *In1* is BYTE#16#3A, *In2* is BYTE#16#28, and *In3* is BYTE#16#73.

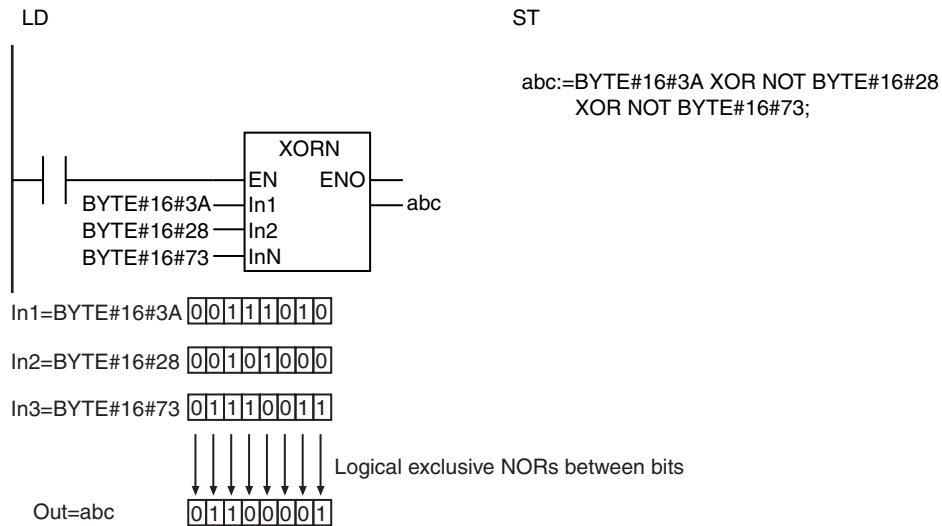

Precautions for Correct Use

The data types of *In1* to *InN* and *Out* must all be the same. Otherwise, a building error will occur.

NOT

The NOT instruction reverses the value of a Boolean variable or the individual bits in a bit string.

Instruction	Name	FB/FUN	Graphic expression	ST expression
NOT	Bit Reversal	FUN		Out:=NOT In;

Variables

Name	Meaning	I/O	Description	Valid range	Unit	Default
In	Data to process	Input	Data to process	Depends on data type.	---	*
Out	Processing result	Output	Processing result	Depends on data type.	---	---

* If you omit the input parameter, the default value is not applied. A building error will occur.

	Boolean	Bit strings				Integers							Real numbers	Times, durations, dates, and text strings						
	BOOL	BYTE	WORD	DWORD	LWORD	USINT	UINT	UDINT	ULINT	SINT	INT	DINT	LINT	REAL	LREAL	TIME	DATE	TOD	DT	STRING
In	OK	OK	OK	OK	OK															
Out	Must be same data type as <i>In</i>																			

Function

The NOT instruction reverses the value of a Boolean variable or the values of individual bits in a bit string. The data to process is in *In*. *In* and processing result *Out* must have the same number of bits, i.e., they must be the same data type.

The following example is for when *In* is BYTE#16#73.

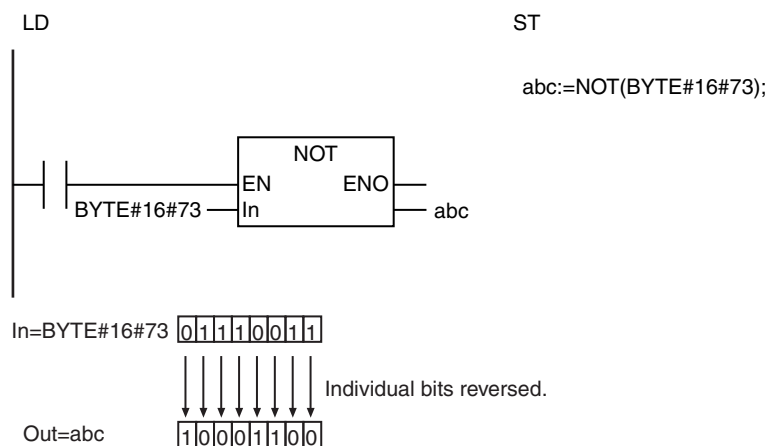

Precautions for Correct Use

The data types of *In* and *Out* must be the same. Otherwise, a building error will occur.

AryAnd, AryOr, AryXor, and AryXorN

These instructions process Boolean variables or individual bits in bit strings between arrays.

AryAnd: Logical AND
 AryOr: Logical OR
 AryXor: Logical Exclusive OR
 AryXorN: Logical Exclusive NOR

Instruction	Name	FB/FUN	Graphic expression	ST expression
AryAnd	Array Logical AND	FUN		AryAnd(In1, In2, Size, AryOut);
AryOr	Array Logical OR	FUN		AryOr(In1, In2, Size, AryOut);
AryXor	Array Logical Exclusive OR	FUN		AryXor(In1, In2, Size, AryOut);
AryXorN	Array Logical Exclusive NOR	FUN		AryXorN(In1, In2, Size, AryOut);

Variables

Name	Meaning	I/O	Description	Valid range	Unit	Default
In1[] and In2[] (arrays)	Array to process	Input	Array to process	Depends on data type.	---	*
Size	Number of elements		Number of elements to process			1
AryOut[] (array)	Processing results array	In-out	Processing results array	Depends on data type.	---	---
Out	Return value	Output	Always TRUE	TRUE only	---	---

* If you omit an input parameter, the default value is not applied. A building error will occur.

	Boolean	Bit strings					Integers							Real numbers	Times, durations, dates, and text strings					
	BOOL	BYTE	WORD	DWORD	LWORD	USINT	UINT	UDINT	ULINT	SINT	INT	DINT	LINT	REAL	LREAL	TIME	DATE	TOD	DT	STRING
In1[] (array)	OK	OK	OK	OK	OK															
In2[] (array)	Must be same data type as In1[]																			
Size							OK													
AryOut[] (array)	Must be same data type as In1[]																			
Out	OK																			

Function

These instructions process *Size* elements from the beginning of arrays to process *In1[]* and *In2[]*. Processing is performed for corresponding bits of corresponding elements. The processing results are stored in corresponding elements of *AryOut[]*. *In1[]* to *In2[]* and *AryOut[]* must be the same data types. The relationships between input and output variables are given in the following tables.

● AryAnd

If both bits are TRUE, then the processing result is TRUE. Otherwise, the processing result is FALSE.

Bit of element in In1[]	Bit of element in In2[]	Bit of Ary-Out[]
FALSE	FALSE	FALSE
FALSE	TRUE	FALSE
TRUE	FALSE	FALSE
TRUE	TRUE	TRUE

● AryOr

If both bits are FALSE, then the processing result is FALSE. Otherwise, the processing result is TRUE.

Bit of element in In1[]	Bit of element in In2[]	Bit of Ary-Out[]
FALSE	FALSE	FALSE
FALSE	TRUE	TRUE
TRUE	FALSE	TRUE
TRUE	TRUE	TRUE

● AryXor

If both bits are the same, then the processing result is FALSE. If one bit is TRUE and the other is FALSE, then the processing result is TRUE.

Bit of element in <i>In1[]</i>	Bit of element in <i>In2[]</i>	Bit of <i>Ary- Out[]</i>
FALSE	FALSE	FALSE
FALSE	TRUE	TRUE
TRUE	FALSE	TRUE
TRUE	TRUE	FALSE

● AryXorN

If both bits are the same, then the processing result is TRUE. If one bit is TRUE and the other is FALSE, then the processing result is FALSE.

Bit of element in <i>In1[]</i>	Bit of element in <i>In2[]</i>	Bit of <i>Ary- Out[]</i>
FALSE	FALSE	TRUE
FALSE	TRUE	FALSE
TRUE	FALSE	FALSE
TRUE	TRUE	TRUE

The following example shows the AryAnd instruction when *Size* is UINT#3.

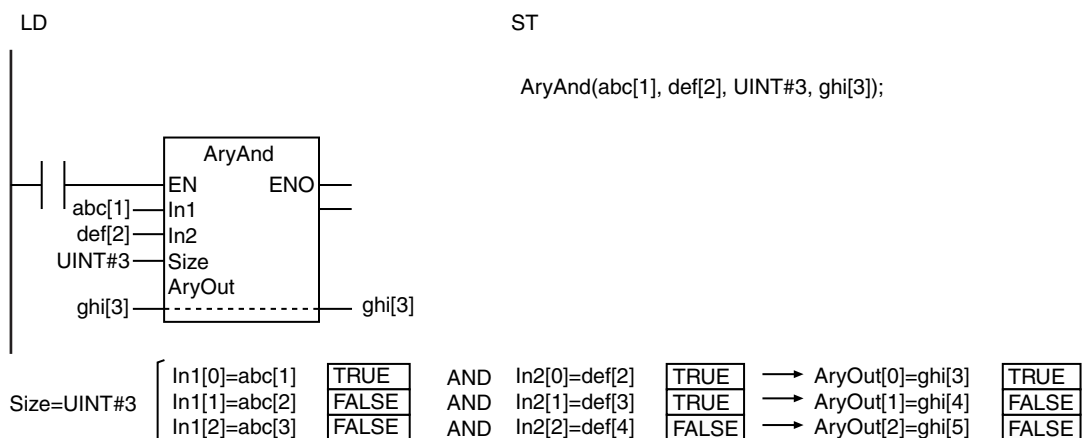

Precautions for Correct Use

- The data types of *In1[]*, *In2[]*, and *AryOut[]* must be the same. If they are different, a building error will occur.
- Use an *AryOut[]* array that has at least as many elements as the value of *Size*.
- The values in *AryOut[]* do not change if the value of *Size* is 0.
- Return value *Out* is not used when the instruction is used in ST.
- An error occurs in the following cases. *ENO* will be FALSE, and *AryOut[]* will not change.
 - The value of *Size* exceeds the number of elements in *In1[]*, *In2[]*, or *AryOut[]*.

Selection Instructions

Instruction	Name	Page
SEL	Binary Selection	2-332
MUX	Multiplexer	2-334
LIMIT	Limiter	2-337
Band	Deadband Control	2-339
Zone	Dead Zone Control	2-342
MAX and MIN	Maximum/Minimum	2-345
AryMax and AryMin	Array Maximum/Array Minimum	2-347
ArySearch	Array Search	2-350

SEL

The SEL instruction selects one of two selections.

Instruction	Name	FB/FUN	Graphic expression	ST expression
SEL	Binary Selection	FUN		Out:=SEL(G, In0, In1);

Variables

Name	Meaning	I/O	Description	Valid range	Unit	Default
G	Gate	Input	FALSE: Selects <i>In0</i> . TRUE: Selects <i>In1</i> .	Depends on data type.	---	FALSE
In0 and In1	Selections		Selections			*
Out	Selection result	Output	Selection result	Depends on data type.	---	---

* If you omit the input parameter, the default value is not applied. A building error will occur.

	Boolean	Bit strings					Integers							Real numbers	Times, durations, dates, and text strings					
	BOOL	BYTE	WORD	DWORD	LWORD	USINT	UINT	UDINT	ULINT	SINT	INT	DINT	LINT	REAL	LREAL	TIME	DATE	TOD	DT	STRING
G	OK																			
In0 and In1	OK	OK	OK	OK	OK	OK	OK	OK	OK	OK	OK	OK	OK	OK	OK	OK	OK	OK	OK	OK
	Enumerations can also be specified.*																			
Out	OK	OK	OK	OK	OK	OK	OK	OK	OK	OK	OK	OK	OK	OK	OK	OK	OK	OK	OK	OK
	Enumerations can also be specified.*																			

* A CPU Unit with unit version 1.02 or later and Sysmac Studio version 1.03 or higher are required to specify enumerations.

Function

The SEL instruction selects one of two selections, *In0* and *In1*. Gate *G* specifies which of *In0* and *In1* to select. If *G* is FALSE, *In0* is assigned to *Out*. If *G* is TRUE, *In1* is assigned to *Out*.

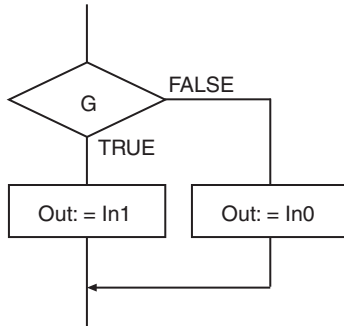

The following example is for when *In0* is INT#10, *In1* is INT#20, and *G* is TRUE. The value of variable *abc* will be INT#20.

LD

ST

```
abc:=SEL(TRUE, INT#10, INT#20);
```

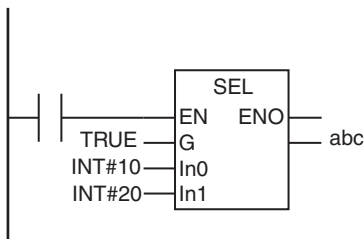

The SEL instruction selects *In0* or *In1*.

G is TRUE, so *In1* (INT#20) is selected and assigned to *abc*.

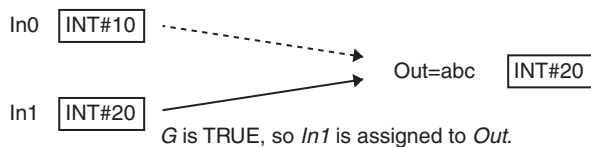

Additional Information



Version Information

With a CPU Unit with unit version 1.02 or later and Sysmac Studio version 1.03 or higher, the MUX instruction (page 2-334) can also be used.

Precautions for Correct Use

- *In0*, *In1*, and *Out* may be different data types, but observe the following precautions.
 - Set the valid range of *Out* to include the valid ranges of *In0* and *In1*.
 - *In0*, *In1*, and *Out* cannot be different varieties of data types (such as a bit string and an integer, or an integer and a text string).

MUX

The MUX instruction selects one of two to five selections.

Instruction	Name	FB/FUN	Graphic expression	ST expression
MUX	Multiplexer	FUN		Out:=MUX(K, In0, In1, ..., InN);

Variables

Name	Meaning	I/O	Description	Valid range	Unit	Default
K	Selector	Input	0: Selects <i>In0</i> . 1: Selects <i>In1</i> . 2: Selects <i>In2</i> . 3: Selects <i>In3</i> . 4: Selects <i>In4</i> .	0 to N	---	*1
In0 to InN	Selections		Selections N is 1 to 4.*2	Depends on data type.	---	0*3
Out	Selection result	Output	Selection result	Depends on data type.	---	---

*1 If you omit an input parameter, the default value is not applied. A building error will occur.

*2 With a CPU Unit with unit version 1.01 or earlier and Sysmac Studio version 1.02 or lower, N is 2 to 4.

*3 If you omit the input parameter that connects to *InN*, the default value is not applied, and a building error will occur. For example, if N is 2 and the input parameters that connect to *In0* and *In1* are omitted, the default values are applied, but if the input parameter that connects to *In2* is omitted, a building error will occur.

	Boolean	Bit strings					Integers							Real numbers	Times, durations, dates, and text strings					
	BOOL	BYTE	WORD	DWORD	LWORD	USINT	UINT	UDINT	ULINT	SINT	INT	DINT	LINT	REAL	LREAL	TIME	DATE	TOD	DT	STRING
K						OK*1			OK*1											
In0 to InN	OK	OK	OK	OK	OK	OK	OK	OK	OK	OK	OK	OK	OK	OK	OK	OK	OK	OK	OK	OK
	Enumerations can also be specified.*2																			
Out	OK	OK	OK	OK	OK	OK	OK	OK	OK	OK	OK	OK	OK	OK	OK	OK	OK	OK	OK	OK
	Enumerations can also be specified.*2																			

*1 With a CPU Unit with unit version 1.02 or later and Sysmac Studio version 1.03 or higher, use a ULINT variable. With a CPU Unit with unit version 1.01 or earlier and Sysmac Studio version 1.02 or lower, use a USINT variable.

*2 A CPU Unit with unit version 1.02 or later and Sysmac Studio version 1.03 or higher are required to specify enumerations.

Function

The MUX instruction selects one of two to five selections, $In0$ to InN .

Selector K specifies which of $In0$ to InN to select.

The value of one of the input variables is assigned to Out according to the value of K . $In0$ is assigned if K is 0, $In1$ is assigned if K is 1, etc.

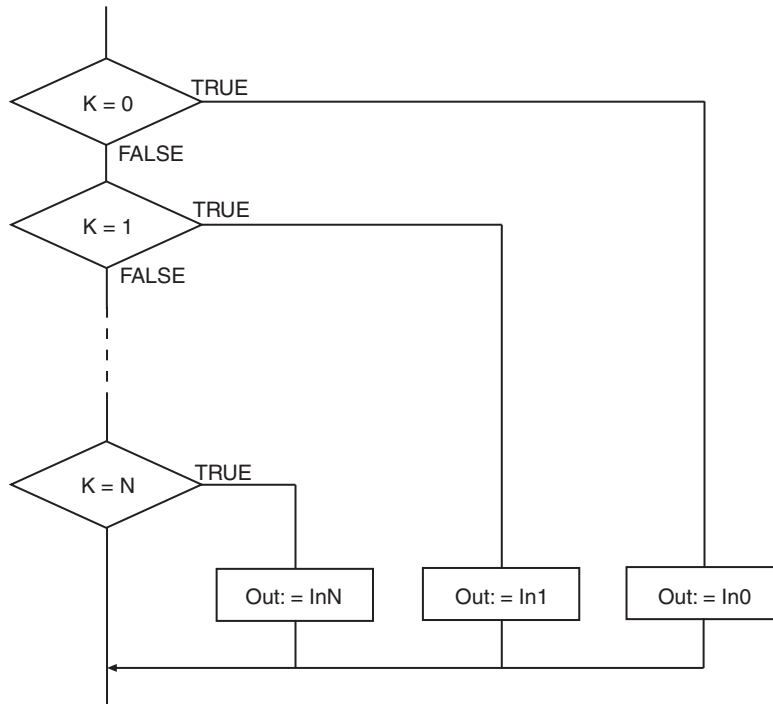

The following example is for when $In0$ is INT#10, $In1$ is INT#20, $In2$ is INT#30, and K is ULINT#2. The value of variable abc will be INT#30.

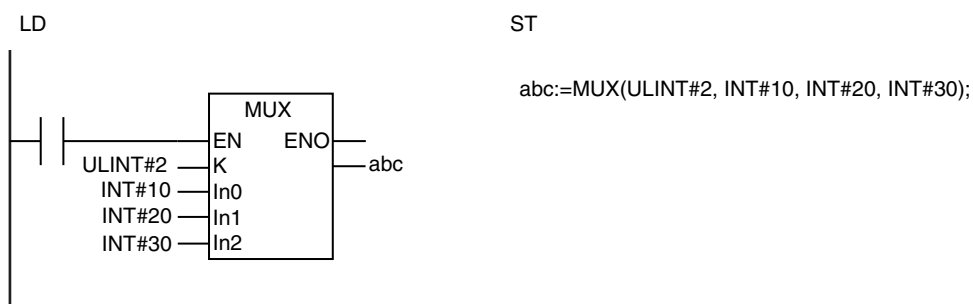

The MUX instruction selects from among $In0$ to InN .

K is ULINT#2, so $In2$ (INT#30) is selected and assigned to abc .

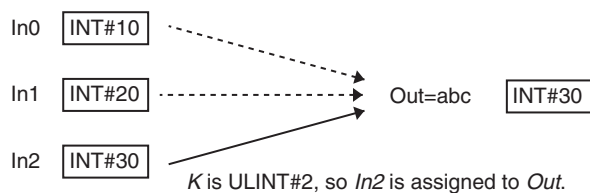

Precautions for Correct Use

- *In0* to *InN* and *Out* may be different data types, but observe the following precautions.
 - Set the valid range of *Out* to include the valid ranges of *In0* to *InN*.
 - *In0* to *InN* and *Out* cannot be different varieties of data types (such as a bit string and an integer, or an integer and a text string).
- An error occurs in the following cases. *ENO* will be FALSE, and *Out* will not change.
 - The value of *K* is outside the valid range (i.e., less than 0 or greater than N).

LIMIT

The LIMIT instruction limits the value of the input variable to the specified minimum and maximum values.

Instruction	Name	FB/FUN	Graphic expression	ST expression
LIMIT	Limiter	FUN		Out:=LIMIT(MN, In, MX);

Variables

Name	Meaning	I/O	Description	Valid range	Unit	Default
MN	Minimum value	Input	Minimum value of limiter	Depends on data type.	---	*
In	Data to limit		Data to limit			
MX	Maximum value		Maximum value of limiter			
Out	Processing result	Output	Processing result	Depends on data type.	---	---

* If you omit an input parameter, the default value is not applied. A building error will occur.

	Boolean	Bit strings				Integers							Real numbers	Times, durations, dates, and text strings						
	BOOL	BYTE	WORD	DWORD	LWORD	USINT	UINT	UDINT	ULINT	SINT	INT	DINT	LINT	REAL	LREAL	TIME	DATE	TOD	DT	STRING
MN						OK	OK	OK	OK	OK	OK	OK	OK	OK	OK					
In						OK	OK	OK	OK	OK	OK	OK	OK	OK	OK					
MX						OK	OK	OK	OK	OK	OK	OK	OK	OK	OK					
Out						OK	OK	OK	OK	OK	OK	OK	OK	OK	OK					

Band

The Band instruction performs deadband control.

Instruction	Name	FB/FUN	Graphic expression	ST expression
Band	Deadband Control	FUN		Out:=Band(MN, In, MX);

Variables

Name	Meaning	I/O	Description	Valid range	Unit	Default
MN	Minimum value	Input	Minimum value of deadband	Depends on data type.	---	*
In	Data to control		Data to control			
MX	Maximum value		Maximum value of deadband			
Out	Processing result	Output	Processing result	Depends on data type.	---	---

* If you omit an input parameter, the default value is not applied. A building error will occur.

	Boolean	Bit strings				Integers								Real numbers		Times, durations, dates, and text strings				
	BOOL	BYTE	WORD	DWORD	LWORD	USINT	UINT	UDINT	ULINT	SINT	INT	DINT	LINT	REAL	LREAL	TIME	DATE	TOD	DT	STRING
MN										OK	OK	OK	OK	OK	OK					
In										OK	OK	OK	OK	OK	OK					
MX										OK	OK	OK	OK	OK	OK					
Out										OK	OK	OK	OK	OK	OK					

Function

The Band instruction controls the value of data to control *In* according to the maximum value, *MX*, and the minimum value, *MN*. The value of processing result *Out* is as shown below.

Value of <i>In</i>	Value of <i>Out</i>
$In < MN$	$In - MN$
$MN \leq In \leq MX$	0
$MX < In$	$In - MX$

The following example is for when *MN* is INT#-10 and *MX* is INT#20.

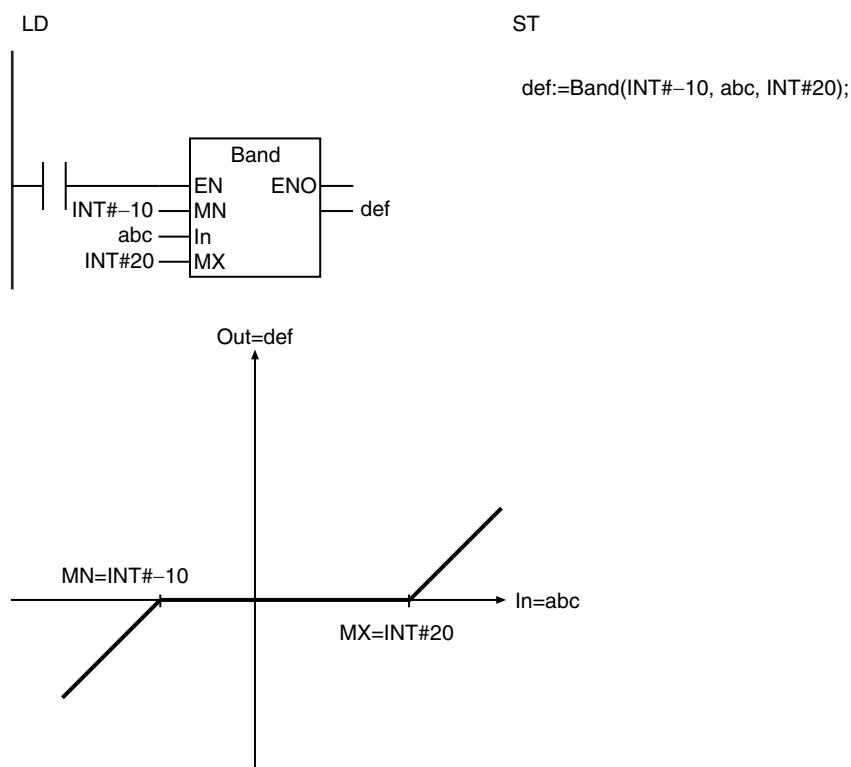

Precautions for Correct Use

- In*, *MN*, *MX*, and *Out* may be different data types, but observe the following precaution.
 - Set the valid range of *Out* to include the valid ranges of *In*, *MN*, and *MX*.
- If the value of *In* is nonnumeric data, the value of *Out* is nonnumeric data.
- If the value of *In*, *MN*, or *MX* is positive infinity or negative infinity, the value of *Out* is as shown below.

Value of <i>In</i>	Value of <i>MN</i>	Value of <i>MX</i>	Value of <i>Out</i>
+∞	+∞	+∞	0
		-∞	Error
	-∞	+∞	0
		-∞	+∞

Value of <i>In</i>	Value of <i>MN</i>	Value of <i>MX</i>	Value of <i>Out</i>
-∞	+∞	+∞	-∞
		-∞	Error
	-∞	+∞	0
		-∞	0

- An error occurs in the following cases. *ENO* will be FALSE, and *Out* will not change.
 - The value of *MX* is smaller than the value of *MN*.
 - Either *MX* or *MN* contains nonnumeric data.
 - The processing result exceeds the valid range of *Out*.

Zone

The Zone instruction adds a bias value to the input value.

Instruction	Name	FB/FUN	Graphic expression	ST expression
Zone	Dead Zone Control	FUN		Out:=Zone(BiasN, In, BiasP);

Variables

Name	Meaning	I/O	Description	Valid range	Unit	Default
BiasN	Negative bias	Input	Negative bias	Depends on data type.	---	*
In	Data to control		Data to control			
BiasP	Positive bias		Positive bias			
Out	Processing result	Output	Processing result	Depends on data type.	---	---

* If you omit an input parameter, the default value is not applied. A building error will occur.

	Boolean	Bit strings					Integers							Real numbers		Times, durations, dates, and text strings				
	BOOL	BYTE	WORD	DWORD	LWORD	USINT	UINT	UDINT	ULINT	SINT	INT	DINT	LINT	REAL	LREAL	TIME	DATE	TOD	DT	STRING
BiasN										OK	OK	OK	OK	OK	OK					
In										OK	OK	OK	OK	OK	OK					
BiasP										OK	OK	OK	OK	OK	OK					
Out										OK	OK	OK	OK	OK	OK					

Function

The Zone instruction controls the value of data to control *In* according to the positive bias, *BiasP*, and the negative bias, *BiasN*. The value of processing result *Out* is as shown below.

Value of <i>In</i>	Value of <i>Out</i>
$In < 0$	$In + BiasN$
$In = 0$	0
$0 < In$	$In + BiasP$

The following example is for when *BiasP* is INT#20 and *BiasN* is INT#-20.

```

LD
                                ST
                                def:=Zone(INT#-20, abc, INT#20);

```

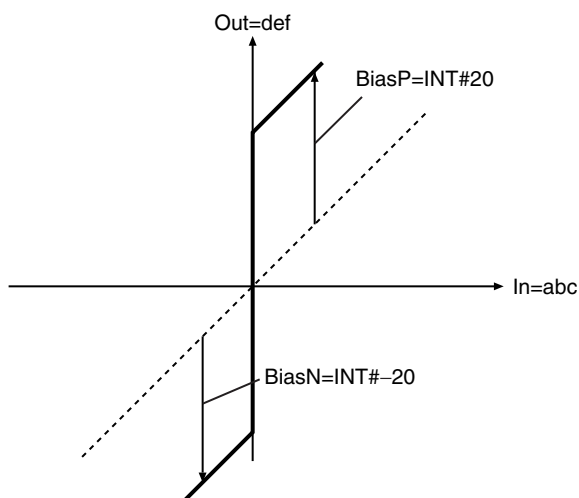
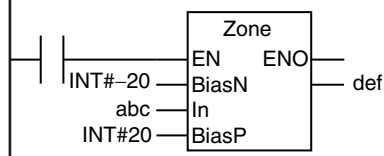

Precautions for Correct Use

- In*, *BiasP*, *BiasN*, and *Out* may be different data types, but observe the following precaution.
 - Set the valid range of *Out* to include the valid ranges of *In*, *BiasP*, and *BiasN*.
- If the value of *In* is nonnumeric data, the value of *Out* is nonnumeric data.
- If the value of *In*, *BiasP*, or *BiasN* is positive infinity or negative infinity, the value of *Out* is as shown below.

Value of <i>In</i>	Value of <i>BiasP</i>	Value of <i>BiasN</i>	Value of <i>Out</i>
+ ∞	+ ∞	+ ∞	+ ∞
		- ∞	+ ∞
	- ∞	+ ∞	Error
		- ∞	0

Value of <i>In</i>	Value of <i>BiasP</i>	Value of <i>BiasN</i>	Value of <i>Out</i>
-∞	+∞	+∞	0
		-∞	-∞
	-∞	+∞	Error
		-∞	-∞

- An error occurs in the following cases. *ENO* will be FALSE, and *Out* will not change.
 - *BiasP* is less than *BiasN*.
 - Either *BiasP* or *BiasN* contains nonnumeric data.
 - The processing result exceeds the valid range of *Out*.

MAX and MIN

MAX: Finds the largest of two to five values.

MIN: Finds the smallest of two to five values.

Instruction	Name	FB/FUN	Graphic expression	ST expression
MAX	Maximum	FUN		Out:=MAX(In1, In2, ..., InN);
MIN	Minimum	FUN		Out:=MIN(In1, In2, ..., InN);

Variables

Name	Meaning	I/O	Description	Valid range	Unit	Default
In1 to InN	Data to process	Input	Data to process, where N is 2 to 5	Depends on data type.	---	0*
Out	Search result	Output	Search result	Depends on data type.	---	---

* If you omit the input parameter that connects to *InN*, the default value is not applied, and a building error will occur. For example, if N is 3 and the input parameters that connect to *In1* and *In2* are omitted, the default values are applied, but if the input parameter that connects to *In3* is omitted, a building error will occur.

	Boolean	Bit strings					Integers							Real numbers		Times, durations, dates, and text strings				
	BOOL	BYTE	WORD	DWORD	LWORD	USINT	UINT	UDINT	ULINT	SINT	INT	DINT	LINT	REAL	LREAL	TIME	DATE	TOD	DT	STRING
In1 to InN						OK	OK	OK	OK	OK	OK	OK	OK	OK	OK					
Out						OK	OK	OK	OK	OK	OK	OK	OK	OK	OK					

Function

● MAX

The MAX instruction finds the largest value of two to five data to process, *In1* to *InN*.

● MIN

The MIN instruction finds the smallest value of two to five data to process, *In1* to *InN*.

The following example is for the MAX instruction when *In1* is INT#10, *In2* is INT#5, *In3* is INT#23, *In4* is INT#14, and *In5* is INT#-5.

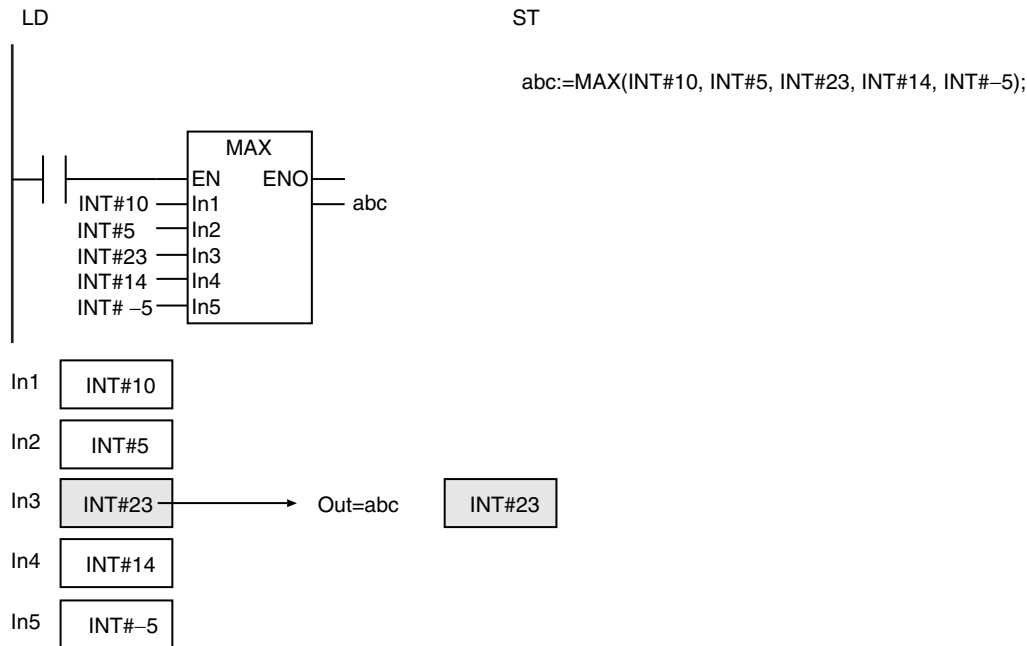

Additional Information

To find the largest or smallest of six or more values, use the AryMax or AryMin instruction (page 2-347).

Precautions for Correct Use

- *In1* to *InN* and *Out* may be different data types, but observe the following precaution.
 - Set the valid range of *Out* to include the valid ranges of *In1* to *InN*.
 - Do not combine signed integers (SINT, INT, DINT, and LINT) together with unsigned integers (USINT, UINT, UDINT, and ULINT) for *In1* to *InN*.
- If *In1* to *InN* are real numbers, the desired results may not be achieved due to error.

AryMax and AryMin

AryMax: Finds the elements with the largest value in a one-dimensional array.

AryMin: Finds the elements with the smallest value in a one-dimensional array.

Instruction	Name	FB/FUN	Graphic expression	ST expression
AryMax	Array Maximum	FUN		Out:=AryMax(In, Size, InOutPos, Num);
AryMin	Array Minimum	FUN		Out:=AryMin(In, Size, InOutPos, Num);

Variables

Name	Meaning	I/O	Description	Valid range	Unit	Default
In[] (array)	Array to search	Input	Array to search	Depends on data type.	---	*
Size	Number of elements to search		Number of elements in In[] to search			1
InOutPos	Found element number	In-out	Array element number where value was found	Depends on data type.	---	---
Out	Search result	Output	Search result	Depends on data type.	---	---
Num	Number found		Number found			

* If you omit the input parameter, the default value is not applied. A building error will occur.

	Boolean	Bit strings				Integers							Real numbers		Times, durations, dates, and text strings					
	BOOL	BYTE	WORD	DWORD	LWORD	USINT	UINT	UDINT	ULINT	SINT	INT	DINT	LINT	REAL	LREAL	TIME	DATE	TOD	DT	STRING
In[] (array)						OK	OK	OK	OK	OK	OK	OK	OK	OK	OK	OK	OK	OK	OK	OK
Size							OK													
InOutPos							OK													
Out						OK	OK	OK	OK	OK	OK	OK	OK	OK	OK	OK	OK	OK	OK	OK
Num							OK													

* You can specify TIME, DATE, TOD, DT, and STRING data with CPU Units with unit version 1.01 or later and Sysmac Studio version 1.02 or higher.

Function

These instructions search *Size* elements in array to search *In[]* starting from *In[0]*. The value that is found is assigned to *Out*, the element number where it was found is assigned to *InOutPos*, and the number of times the value was found is assigned to *Num*. If *Num* is greater than 1, the value in *InOutPos* is the number of the lowest element that contains the value that was found.

The relationship between values with data types that are not integers or real numbers are determined as given in the following table.

Data type	Relationship
TIME	The numerically larger value is considered to be larger.
DATE, TOD, or DT	Later dates or times of day are considered to be larger.
STRING	The specifications are the same as for the LTascii, LEascii, GTascii, and GEascii instructions (page 2-104). Refer to the specified page for details.

● AryMax

The AryMax instruction finds the largest value.

● AryMin

The AryMin instruction finds the smallest value.

The following example shows the AryMax instruction when *Size* is UINT#6.

The input parameter that is passed to *In[]* is *abc[2]*, so the search starts from *abc[2]*.

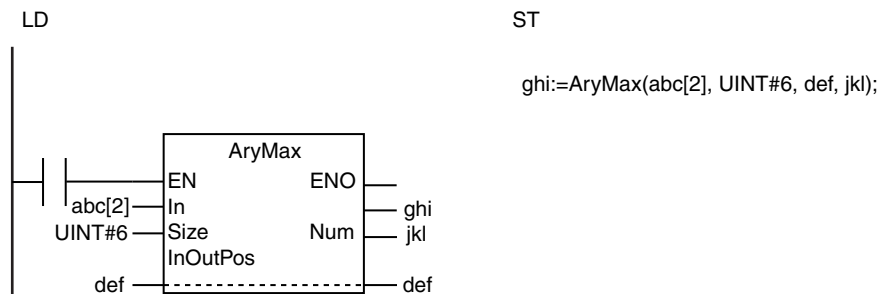

The lowest element number that contains the largest value is 3.

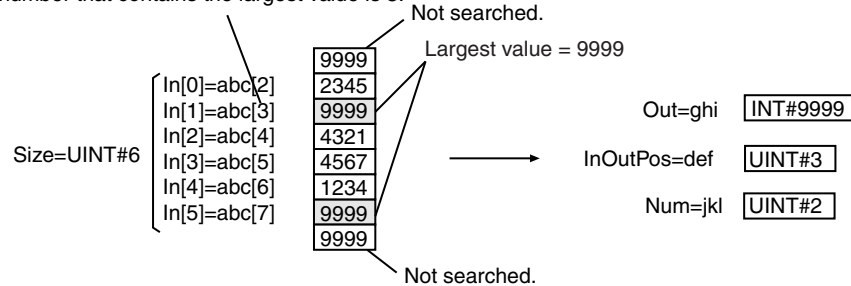

Additional Information

When you compare TIME, DT, or TOD data, adjust the data so that the precision of the values is the same. Use the following instructions to adjust the precision of the values: TruncTime (page 2-652), TruncDt (page 2-656), and TruncTod (page 2-660).

Precautions for Correct Use

- If you use a different data type for *In[]* and *Out*, make sure the valid range of *Out* includes the valid range of *In[]*.

- If *In[]* contains real numbers, the desired results may not be achieved due to error.
- Always used a one-dimensional array for *In[]*.
- If the value of *Size* is 0, the values of *Out* and *Num* are 0. The value of *InOutPos* does not change.
- If *In[]* contains STRING data and the value of *Size* is 0, *Out* is a text string containing only the NULL character.
- An error occurs in the following cases. *ENO* will be FALSE, and *Out* will not change.
 - The value of *Size* is outside of the valid range.
 - *Size* exceeds the array area of *In[]*.
 - *In[]* is not a one-dimensional array.
 - *In[]* is STRING data and it does not end in a NULL character.

ArySearch

The ArySearch instruction searches for the specified value in a one-dimensional array.

Instruction	Name	FB/FUN	Graphic expression	ST expression
ArySearch	Array Search	FUN	<pre> graph LR subgraph ArySearch EN --- ENO In --- In Size --- Size Key --- Key InOutPos --- InOutPos ENO --- ENO Num --- Num Out --- Out end </pre>	Out:=ArySearch(In, Size, Key, InOutPos, Num);

Variables

Name	Meaning	I/O	Description	Valid range	Unit	Default
In[] (array)	Array to search	Input	Array to search	Depends on data type.		*
Size	Number of elements to search		Number of elements in <i>In[]</i> to search	1 to 65535	---	1
Key	Search key		Value to search for	Depends on data type.		---
InOutPos	Found element number	In-out	Array element number where value was found	Depends on data type.	---	---
Out	Search result	Output	Search result	Depends on data type.	---	---
Num	Number found		Number found			

* If you omit an input parameter, the default value is not applied. A building error will occur.

	Boolean	Bit strings					Integers							Real numbers	Times, durations, dates, and text strings						
	BOOL	BYTE	WORD	DWORD	LWORD	USINT	UINT	UDINT	ULINT	SINT	INT	DINT	LINT	REAL	LREAL	TIME	DATE	TOD	DT	STRING	
In[] (array)	OK	OK	OK	OK	OK	OK	OK	OK	OK	OK	OK	OK	OK	OK	OK	OK	OK	OK	OK	OK	OK
	Arrays of enumerations can also be specified.																				
Size						OK															
Key	Must be same data type as the elements of <i>In[]</i> .																				
InOutPos						OK															
Out	OK																				
Num						OK															

* You can specify TIME, DATE, TOD, and DT data with CPU Units with unit version 1.01 or later and Sysmac Studio version 1.02 or higher.

Function

The ArySearch instruction searches *Size* elements of one-dimensional array to search *In[]* for elements with the same value as search key *Key*. The search starts from *In[0]*.

The values of search result *Out*, found element number *InOutPos*, and number found *Num* are as follows:

Element with same value as Key	Out	InOutPos	Num
Exists.	TRUE	Lowest element number that contains the same value as Key	Number of elements with same value as Key
Does not exist.	FALSE	Does not change.	0

The relationship between values with data types that are not integers or real numbers are determined as given in the following table.

Data type	Relationship
TIME	The numerically larger value is considered to be larger.
DATE, TOD, or DT	Later dates or times of day are considered to be larger.

The following example is for when *Size* is UINT#6 and *Key* is INT#5555.

The input parameter that is passed to *In[]* is *abc[2]*, so the search starts from *abc[2]*.

```
LD                                     ST
                                     ghi:=ArySearch(abc[2], UINT#6, INT#5555, def, jkl);
```

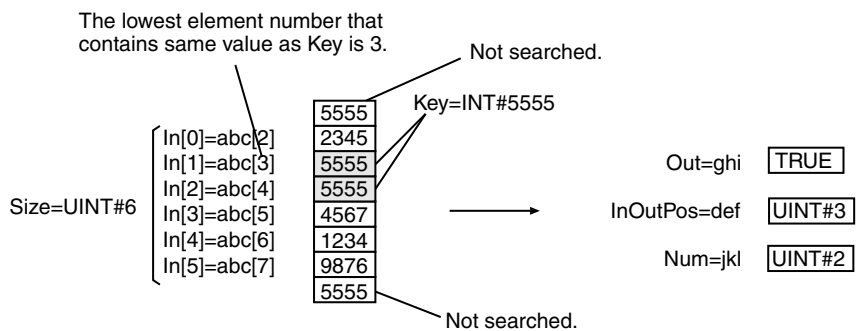
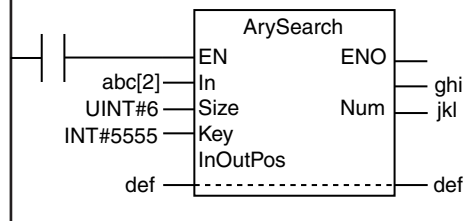

Additional Information

When you compare TIME, DT, or TOD data, adjust the data so that the precision of the values is the same. Use the following instructions to adjust the precision of the values: TruncTime (page 2-652), TruncDt (page 2-656), and TruncTod (page 2-660).

Precautions for Correct Use

- Always use a one-dimensional array for *In[]*.
- Make sure that *Key* has the same data type as the elements of *In[]*.
- If the value of *Size* is 0, the values of *Out* and *Num* are 0. The value of *InOutPos* does not change.
- Always use a variable for the input parameter to pass to *Key*. A building error will occur if a constant is passed.
- If *Key* is an enumeration, you cannot directly pass an enumerator to it. A building error will occur if an enumerator is passed to it directly.
- An error occurs in the following cases. *ENO* will be FALSE, and *Out*, *Num*, and *InOutPos* will not change.
 - *Size* exceeds the array area of *In[]*.
 - *In[]* is STRING data and it does not end in a NULL character.
 - *In[]* is not a one-dimensional array.

Data Movement Instructions

Instruction	Name	Page
MOVE	Move	2-354
MoveBit	Move Bit	2-357
MoveDigit	Move Digit	2-359
TransBits	Move Bits	2-361
MemCopy	Memory Copy	2-363
SetBlock	Block Set	2-365
Exchange	Data Exchange	2-367
AryExchange	Array Data Exchange	2-369
AryMove	Array Move	2-371
Clear	Initialize	2-373
Copy**ToNum (Bit String to Signed Integer)	Bit Pattern Copy (Bit String to Signed Integer) Group	2-375
Copy**To*** (Bit String to Real Number)	Bit Pattern Copy (Bit String to Real Number) Group	2-377
CopyNumTo** (Signed Integer to Bit String)	Bit Pattern Copy (Signed Integer to Bit String) Group	2-379
CopyNumTo*** (Signed Integer to Real Number)	Bit Pattern Copy (Signed Integer to Real Number) Group	2-381
Copy**To*** (Real Number to Bit String)	Bit Pattern Copy (Real Number to Bit String) Group	2-383
Copy**ToNum (Real Number to Signed Integer)	Bit Pattern Copy (Real Number to Signed Integer) Group	2-385

MOVE

The MOVE instruction moves the value of a constant or variable to another variable.

Instruction	Name	FB/FUN	Graphic expression	ST expression
MOVE	Move	FUN		Out:=In;

Variables

Name	Meaning	I/O	Description	Valid range	Unit	Default
In	Move source	Input	Move source	Depends on data type.	---	*
Out	Move destination	Output	Move destination	Depends on data type.	---	*

* If you omit the input parameter, the default value is not applied. A building error will occur.

	Boolean	Bit strings					Integers							Real numbers	Times, durations, dates, and text strings						
		BOOL	BYTE	WORD	DWORD	LWORD	USINT	UINT	UDINT	ULINT	SINT	INT	DINT		LINT	REAL	LREAL	TIME	DATE	TOD	DT
In	OK	OK	OK	OK	OK	OK	OK	OK	OK	OK	OK	OK	OK	OK	OK	OK	OK	OK	OK	OK	OK
An enumeration, array, array element, structure, or structure member can also be specified.																					
Out	OK	OK	OK	OK	OK	OK	OK	OK	OK	OK	OK	OK	OK	OK	OK	OK	OK	OK	OK	OK	OK
Must be the same data type as <i>In</i> if <i>In</i> is an enumeration, array element, structure, or structure member. Must be an array with the same data type, size, and subscripts if <i>In</i> is an array.																					

Function

The MOVE instruction moves the value in move source *In* to move destination *Out*. The input parameter that is passed to *In* can be a variable or constant. You can specify an enumeration, array, array element, structure, or structure member for *In*.

The following figure shows a programming example. The content of variable *abc* is moved to variable *def*.

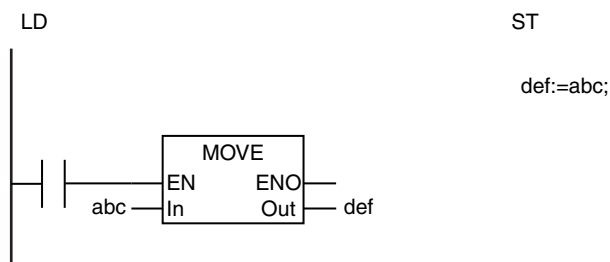

The MOVE instruction moves the value of *In* to *Out*.

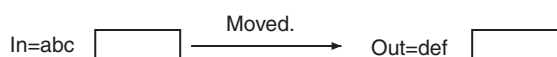

Additional Information

- When moving an array, you can move either one element or all of the elements in the array. To move only one element, add the subscript to the array variable name. To move the entire array, do not add the subscript to the array variable name.

Moving One Array Element

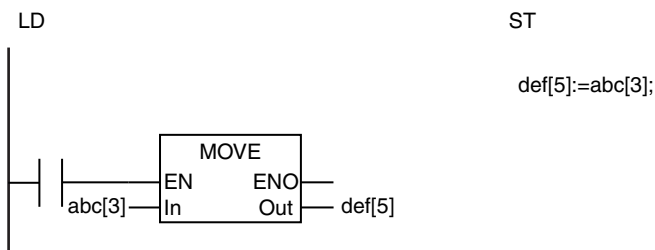

Moving All Array Elements

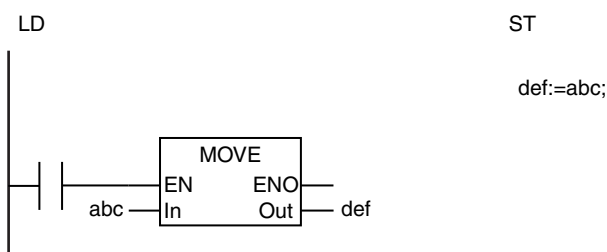

- When moving a structure, you can move either one member or all of the members in the structure. To move only one member, specify the member. To move the entire structure, give only the structure name.

Moving One Member of a Structure

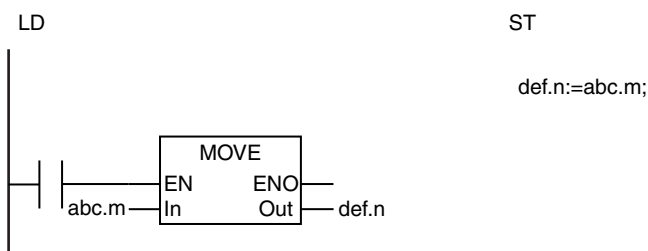

Moving the Entire Structure

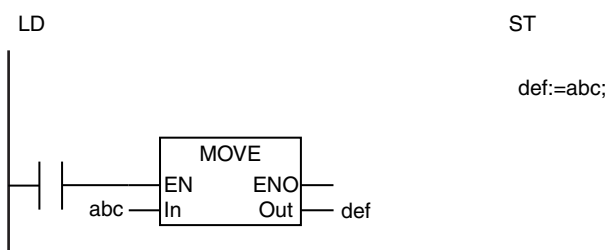

- You can use the MemCopy instruction to move an entire array faster than with the MOVE instruction.

Precautions for Correct Use

- The data types of *In* and *Out* can be different as long as they are both in one of the following groups. The valid range of *Out* must include the valid range of *In*.

- BYTE, WORD, DWORD, and LWORD
- USINT, UINT, UDINT, ULINT, SINT, INT, DINT, LINT, REAL, and LREAL
- If *In* is an enumeration, array element, structure, or structure member, then *Out* must have the same data type as *In*.
- If *In* is an array, an array of the same data type, size, and subscripts must be used for *Out*.

MoveBit

The MoveBit instruction moves one bit in a bit string.

Instruction	Name	FB/FUN	Graphic expression	ST expression
MoveBit	Move Bit	FUN	<pre> graph LR subgraph MoveBit EN[EN] In[In] InPos[InPos] InOut[InOut] InOutPos[InOutPos] EN --- ENO[ENO] In --- InOut InPos --- InOut InOut --- InOut InOutPos --- InOut end InOut --- Out[Out] </pre>	MoveBit(In, InPos, InOut, InOutPos);

Variables

Name	Meaning	I/O	Description	Valid range	Unit	Default
In	Move source	Input	Move source	Depends on data type.	---	*
InPos	Move source bit		Position of bit in <i>In</i> to move	0 to No. of bits in <i>In</i> - 1		0
InOutPos	Move destination bit		Position of bit in <i>Out</i> to receive the bit	0 to No. of bits in <i>InOut</i> - 1		
InOut	Move destination	In-out	Move destination	Depends on data type.	---	---
Out	Return value	Output	Always TRUE	TRUE only	---	---

* If you omit the input parameter, the default value is not applied. A building error will occur.

	Boolean	Bit strings				Integers							Real numbers		Times, durations, dates, and text strings					
	BOOL	BYTE	WORD	DWORD	LWORD	USINT	UINT	UDINT	ULINT	SINT	INT	DINT	LINT	REAL	LREAL	TIME	DATE	TOD	DT	STRING
In		OK	OK	OK	OK															
InPos						OK														
InOutPos						OK														
InOut		OK	OK	OK	OK															
Out	OK																			

Function

The MoveBit instruction moves one bit from the bit position *InPos* in move source *In* to the bit position *InOutPos* in move destination *InOut*.

The following example is for when *InPos* is USINT#3 and *InOutPos* is USINT#5.

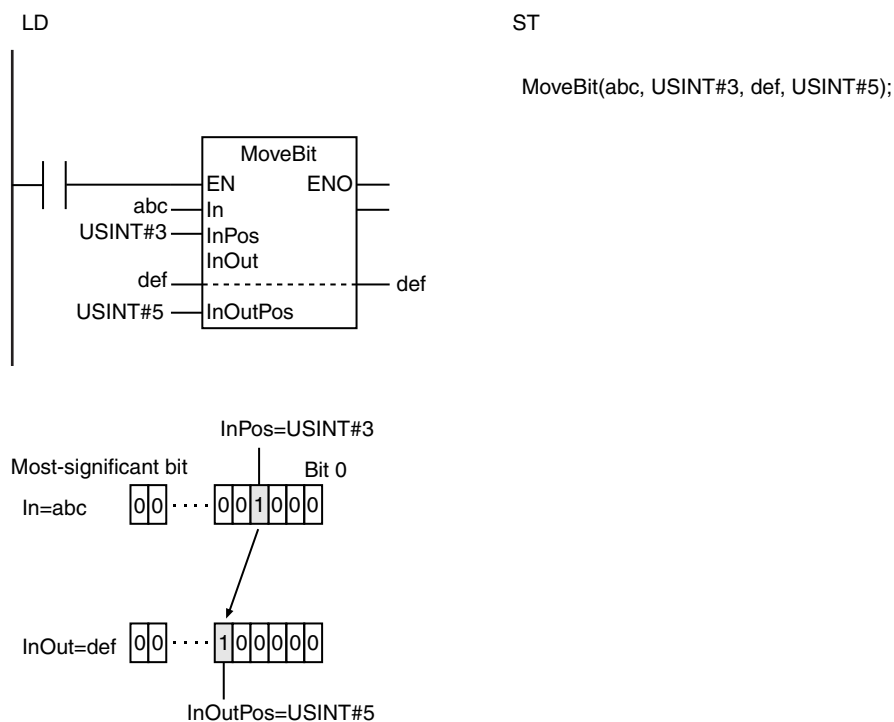

Precautions for Correct Use

- Return value *Out* is not used when the instruction is used in ST.
- An error occurs in the following cases. *ENO* will be FALSE, and *InOut* will not change.
 - The value of *InPos* is outside of the valid range.
 - The value of *InOutPos* is outside of the valid range.

MoveDigit

The MoveDigit instruction moves digits (4 bits per digit) in a bit string.

Instruction	Name	FB/FUN	Graphic expression	ST expression
MoveDigit	Move Digit	FUN		MoveDigit(In, InPos, InOut, InOutPos, Size);

Variables

Name	Meaning	I/O	Description	Valid range	Unit	Default
In	Move source	Input	Move source	Depends on data type.	---	*1
InPos	Move source digit		Position of digit in <i>In</i> to move	*2		0
InOutPos	Move destination digit		Position of digit in <i>Out</i> to receive the digit	*3		
Size	Number of digits		Number of digits to move	*4		1
InOut	Move destination	In-out	Move destination	Depends on data type.	---	---
Out	Return value	Output	Always TRUE	TRUE only	---	---

*1 If you omit the input parameter, the default value is not applied. A building error will occur.

*2 0 to No. of bits in $In/4 - 1$

*3 0 to No. of bits in $InOut/4 - 1$

*4 0 to No. of bits in $In/4$

	Boolean	Bit strings				Integers							Real numbers		Times, durations, dates, and text strings					
	BOOL	BYTE	WORD	DWORD	LWORD	USINT	UINT	UDINT	ULINT	SINT	INT	DINT	LINT	REAL	LREAL	TIME	DATE	TOD	DT	STRING
In		OK	OK	OK	OK															
InPos						OK														
InOutPos						OK														
Size						OK														
InOut		OK	OK	OK	OK															
Out	OK																			

Function

The MoveDigit instruction moves *Size* digits from the *InPos* digit in move source *In* to the *InOutPos* digit in move destination *InOut*. One digit is four bits.

The following example is for when *InPos* is USINT#1, *InOutPos* is USINT#2, and *Size* is USINT#2.

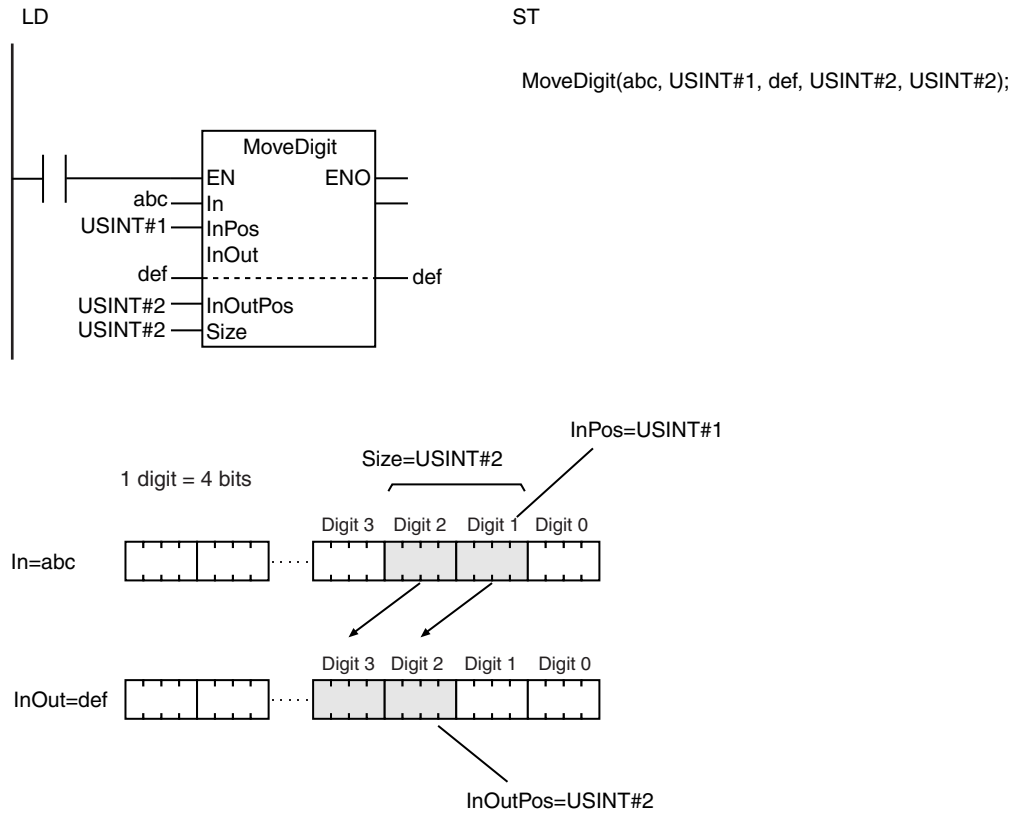

Precautions for Correct Use

- If the position of the digit at the destination exceeds the most-significant digit of *InOut*, the remaining digits are stored the least-significant digits of *InOut*.
- If the position of the digit at the source exceeds the most-significant digit of *In*, the remaining digits are moved to the least-significant digits of *In*.
- If the value of *Size* is 0, the value of *Out* will be TRUE and *InOut* will not change.
- Return value *Out* is not used when the instruction is used in ST.
- An error occurs in the following cases. *ENO* will be FALSE, and *InOut* will not change.
 - The value of *InPos* is outside of the valid range.
 - The value of *InOutPos* is outside of the valid range.
 - The value of *Size* is outside of the valid range.

TransBits

The TransBits instruction moves one or more bits in a bit string.

Instruction	Name	FB/FUN	Graphic expression	ST expression
TransBits	Move Bits	FUN		TransBits(In, InPos, InOut, InOutPos, Size);

Variables

Name	Meaning	I/O	Description	Valid range	Unit	Default
In	Move source	Input	Move source	Depends on data type.	---	*1
InPos	Move source bit		Position of bit in <i>In</i> to move	*2		0
InOutPos	Move destination bit		Position of bit in <i>Out</i> to receive the bit	*3		
Size	Number of bits		Number of bits to move	*4		1
InOut	Move destination	In-out	Move destination	Depends on data type.	---	---
Out	Return value	Output	Always TRUE	TRUE only	---	---

*1 If you omit an input parameter, the default value is not applied. A building error will occur.

*2 0 to No. of bits in *In* – 1

*3 0 to No. of bits in *InOut* – 1

*4 0 to No. of bits in *In*

	Boolean	Bit strings				Integers							Real numbers		Times, durations, dates, and text strings					
	BOOL	BYTE	WORD	DWORD	LWORD	USINT	UINT	UDINT	ULINT	SINT	INT	DINT	LINT	REAL	LREAL	TIME	DATE	TOD	DT	STRING
In		OK	OK	OK	OK															
InPos						OK														
InOutPos						OK														
Size						OK														
InOut		OK	OK	OK	OK															
Out	OK																			

Function

The TransBis instruction moves *Size* bits from the *InPos* bit in move source *In* to the *InOutPos* bit in move destination *InOut*.

The following example is for when *InPos* is USINT#3, *InOutPos* is USINT#4, and *Size* is USINT#2.

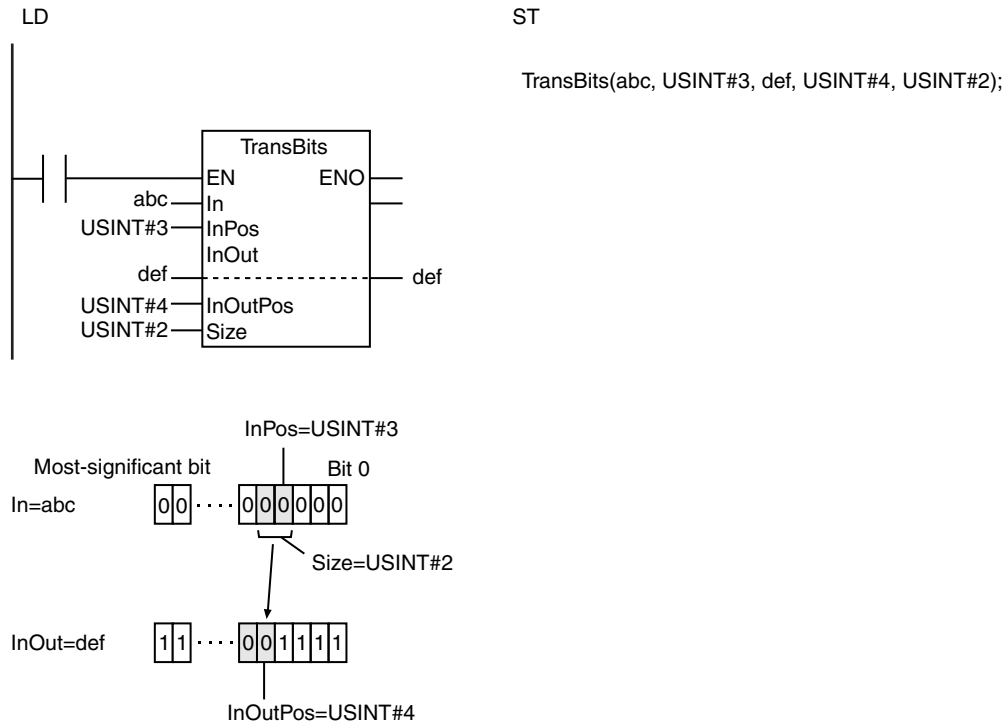

Additional Information

The bits in the move source and move destination can overlap.

Precautions for Correct Use

- Set the instruction so that the positions of the bits at the source and destination do not exceed the most-significant bit in *In* or *InOut*. An error will occur and the instruction will not operate.
- Nothing is moved if the value of *Size* is 0.
- The bits in *InOut* that are not involved in the move operation do not change.
- Return value *Out* is not used when the instruction is used in ST.
- An error occurs in the following cases. *ENO* will be FALSE, and *InOut* will not change.
 - The value of *InPos* is outside of the valid range.
 - The value of *InOutPos* is outside of the valid range.
 - The value of *Size* is outside of the valid range.
 - The value of *InPos* or *Size* exceeds the number of bits in *In*.
 - The value of *InOutPos* or *Size* exceeds the number of bits in *InOut*.

MemCopy

The MemCopy instruction moves one or more array elements. The move source and move destination must have the same data type.

Instruction	Name	FB/FUN	Graphic expression	ST expression
MemCopy	Memory Copy	FUN		MemCopy(In, AryOut, Size);

Variables

Name	Meaning	I/O	Description	Valid range	Unit	Default
In[] (array)	Move source array	Input	Move source array	Depends on data type.	---	*
Size	Number of elements		Number of array elements to move			1
AryOut[] (array)	Move destination array	In-out	Move destination array	Depends on data type.	---	---
Out	Return value	Output	Always TRUE	TRUE only	---	---

* If you omit the input parameter, the default value is not applied. A building error will occur.

	Boolean	Bit strings					Integers							Real numbers	Times, durations, dates, and text strings					
	BOOL	BYTE	WORD	DWORD	LWORD	USINT	UINT	UDINT	ULINT	SINT	INT	DINT	LINT	REAL	LREAL	TIME	DATE	TOD	DT	STRING
In[] (array)	OK	OK	OK	OK	OK	OK	OK	OK	OK	OK	OK	OK	OK	OK	OK	OK	OK	OK	OK	OK
	Arrays of enumerations or structures can also be specified.																			
Size							OK													
AryOut[] (array)	Must be an array with the same data type as In[].																			
Out	OK																			

Function

The MemCopy instruction moves *Size* elements of move source array *In[]* starting from *In[0]* to move destination array *AryOut[]* starting from *AryOut[0]*.

The following example is for when *Size* is UINT#3.

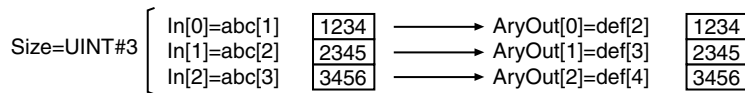
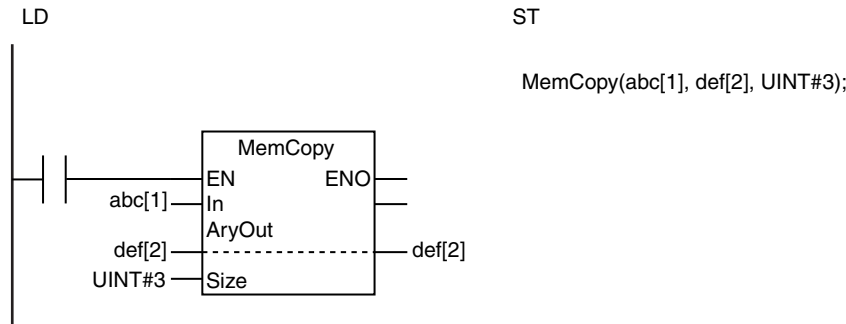

Additional Information

- You can specify different positions in the same array for *In[]* and *AryOut[]*. The source and destination data can overlap.

The following example is for when *In* is *A[2]*, *AryOut* is *A[4]*, and *Size* is UINT#3.

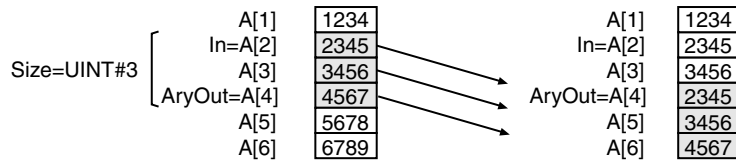

- Use the AryMove instruction (page 2-371) if the source and destination have different data types.
- If the data types of *In[]* and *AryOut[]* are the same, this instruction is faster than the AryMove instruction.
- Use the MOVE instruction (page 2-354) to move variables that are not arrays.

Precautions for Correct Use

- Use the same data type for *In[]* and *AryOut[]*. If they are different, a building error will occur.
- If *In[]* and *AryOut[]* are STRING arrays, their sizes must be the same.
- If the value of *Size* is 0, the value of *Out* will be TRUE and *AryOut[]* will not change.
- Return value *Out* is not used when the instruction is used in ST.
- An error occurs in the following cases. *ENO* will be FALSE, and *AryOut[]* will not change.
 - Size* exceeds the array area of *In[]*.
 - Size* exceeds the array area of *AryOut[]*.

SetBlock

The SetBlock instruction moves the value of a variable or constant to one or more array elements.

Instruction	Name	FB/FUN	Graphic expression	ST expression
SetBlock	Block Set	FUN		SetBlock(In, AryOut, Size);

Variables

Name	Meaning	I/O	Description	Valid range	Unit	Default
In	Move source	Input	Move source	Depends on data type.	---	*
Size	Number of elements		Number of array elements to move			1
AryOut[] (array)	Move destination array	In-out	Move destination array	Depends on data type.	---	---
Out	Return value	Output	Always TRUE	TRUE only	---	---

* If you omit the input parameter, the default value is not applied. A building error will occur.

	Boolean	Bit strings				Integers							Real numbers	Times, durations, dates, and text strings						
	BOOL	BYTE	WORD	DWORD	LWORD	USINT	UINT	UDINT	ULINT	SINT	INT	DINT	LINT	REAL	LREAL	TIME	DATE	TOD	DT	STRING
In	OK	OK	OK	OK	OK	OK	OK	OK	OK	OK	OK	OK	OK	OK	OK	OK	OK	OK	OK	OK
	An enumeration, structure, or structure member can also be specified.																			
Size						OK														
AryOut[] (array)	Must be an array with elements that have the same data type as <i>In</i> .																			
Out	OK																			

Function

The SetBlock instruction moves the value of move source *In* to *Size* locations in move destination array *AryOut[]* starting from *AryOut[0]*.

The following example is for when *Size* is UINT#3.

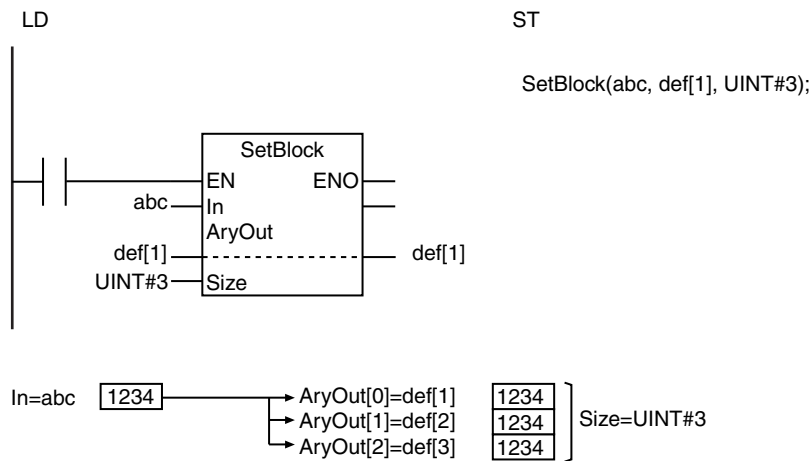

Precautions for Correct Use

- Use the same data type for *In* and *AryOut[]*. If they are different, a building error will occur.
- If *In* and *AryOut[]* are STRING data, their sizes must be the same.
- If the value of *Size* is 0, the value of *Out* will be TRUE and *AryOut[]* will not change.
- Return value *Out* is not used when the instruction is used in ST.
- An error occurs in the following case. *ENO* will be FALSE, and *AryOut[]* will not change.
 - The value of *Size* exceeds the array area of *AryOut[]*.

Exchange

The Exchange instruction exchanges the values of two variables.

Instruction	Name	FB/FUN	Graphic expression	ST expression
Exchange	Data Exchange	FUN		Exchange(InOut1, InOut2);

Variables

Name	Meaning	I/O	Description	Valid range	Unit	Default
InOut1 and InOut2	Data to exchange	In-out	Data to exchange	Depends on data type.	---	---
Out	Return value	Output	Always TRUE	TRUE only	---	---

	Boolean		Bit strings				Integers							Real numbers		Times, durations, dates, and text strings				
	BOOL	BYTE	WORD	DWORD	LWORD	USINT	UINT	UDINT	ULINT	SINT	INT	DINT	LINT	REAL	LREAL	TIME	DATE	TOD	DT	STRING
InOut1	OK	OK	OK	OK	OK	OK	OK	OK	OK	OK	OK	OK	OK	OK	OK	OK	OK	OK	OK	OK
	An enumeration, structure, or structure member can also be specified.																			
InOut2	Must be same data type as <i>InOut1</i> .																			
Out	OK																			

Function

The Exchange instruction exchanges the values of data to exchange *InOut1* and *InOut2*. You can specify enumerations, structures, or structure members for *InOut1* and *InOut2*.

The following figure shows a programming example. The values in variables *abc* and *def* are exchanged.

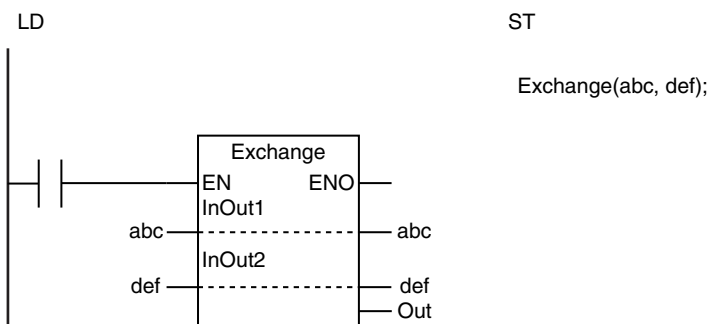

The Exchange instruction exchanges the values of *InOut1* and *InOut2*.

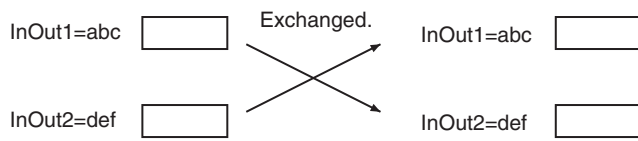

Precautions for Correct Use

- The data types of *InOut1* and *InOut2* must be the same. If they are different, a building error will occur.
- Return value *Out* is not used when the instruction is used in ST.
- An error occurs in the following cases. *ENO* will be FALSE, and *InOut1* and *InOut2* will not change.
 - Both *InOut1* and *InOut2* are STRING data and the length of the text string in one of them does not fit into the other.

AryExchange

The AryExchange instruction exchanges the elements of two arrays.

Instruction	Name	FB/FUN	Graphic expression	ST expression
AryExchange	Array Data Exchange	FUN		AryExchange(InOut1, InOut2, Size);

Variables

Name	Meaning	I/O	Description	Valid range	Unit	Default
Size	Number of elements	Input	Number of elements to exchange	Depends on data type.	---	1
InOut1[] and InOut2[] (arrays)	Arrays to exchange	In-out	Arrays to exchange	Depends on data type.	---	---
Out	Return value	Output	Always TRUE	TRUE only	---	---

	Boolean	Bit strings				Integers							Real numbers	Times, durations, dates, and text strings						
	BOOL	BYTE	WORD	DWORD	LWORD	USINT	UINT	UDINT	ULINT	SINT	INT	DINT	LINT	REAL	LREAL	TIME	DATE	TOD	DT	STRING
Size							OK													
InOut1[] (array)	OK	OK	OK	OK	OK	OK	OK	OK	OK	OK	OK	OK	OK	OK	OK	OK	OK	OK	OK	OK
InOut2[] (array)	Must be an array with the same data type as <i>InOut1[]</i> .																			
Out	OK																			

Function

The AryExchange instruction exchanges *Size* elements from *InOut1[0]* of array to exchange *InOut1[]* with *Size* elements from *InOut2[0]* of array to exchange *InOut2[]*.

The following example is for when *Size* is *UINT#2*.

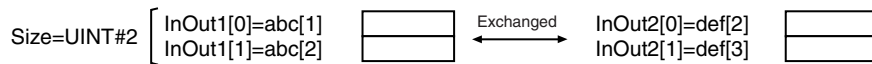
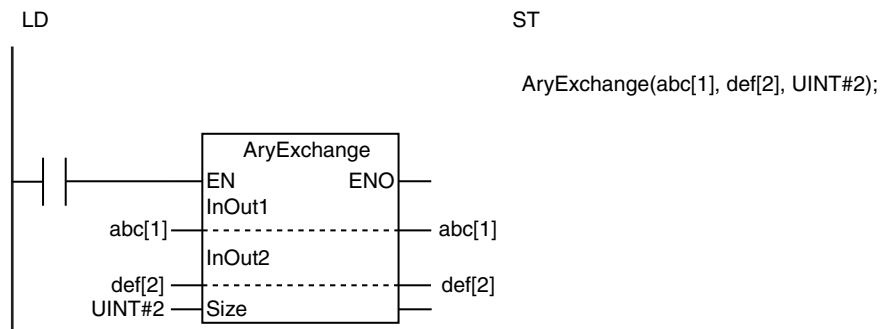

Additional Information

- Use the MOVE instruction (page 2-354) to assign constants to variables.
- Use the MemCopy instruction (page 2-363) to copy the values of variables to other variables.

Precautions for Correct Use

- Use the same data type for the elements of *InOut1[]* and *InOut2[]*. If they are different, a building error will occur.
- If the value of *Size* is 0, the value of *Out* will be TRUE and *InOut1[]* and *InOut2[]* will not change.
- Return value *Out* is not used when the instruction is used in ST.
- An error occurs in the following cases. *ENO* will be FALSE, and *InOut1[]* and *InOut2[]* will not change.
 - The value of *Size* exceeds the array range of *InOut1[]* or *InOut2[]*.
 - *InOut1[]* and *InOut2[]* are STRING arrays and there is an element with a text string that exceeds the size of the element in the other array.
 - *InOut1[]* and *InOut2[]* are STRING arrays and there is an element that does not end in a NULL character.

AryMove

The AryMove instruction moves one or more array elements. The data types of the move source and move destination can be different.

Instruction	Name	FB/FUN	Graphic expression	ST expression
AryMove	Array Move	FUN		AryMove(In, AryOut, Size);

Variables

Name	Meaning	I/O	Description	Valid range	Unit	Default
In[] (array)	Move source array	Input	Array to move	Depends on data type.	---	*
Size	Number of elements		Number of elements to move			1
AryOut[] (array)	Move result array	In-out	Move result array	Depends on data type.	---	---
Out	Return value	Output	Always TRUE	TRUE only	---	---

* If you omit the input parameter, the default value is not applied. A building error will occur.

	Boolean	Bit strings				Integers							Real numbers	Times, durations, dates, and text strings						
	BOOL	BYTE	WORD	DWORD	LWORD	USINT	UINT	UDINT	ULINT	SINT	INT	DINT	LINT	REAL	LREAL	TIME	DATE	TOD	DT	STRING
In[] (array)	OK	OK	OK	OK	OK	OK	OK	OK	OK	OK	OK	OK	OK	OK	OK	OK	OK	OK	OK	OK
	Arrays of enumerations or structures can also be specified.																			
Size							OK													
AryOut[] (array)	OK	OK	OK	OK	OK	OK	OK	OK	OK	OK	OK	OK	OK	OK	OK	OK	OK	OK	OK	OK
	Arrays of enumerations or structures can also be specified.																			
Out	OK																			

Function

The AryMove instruction moves *Size* elements of move source array *In[]* starting from *In[0]* to move result array *AryOut[]* starting from *AryOut[0]*. The data types of *In[]* and *AryOut[]* can be different.

The following example is for when *Size* is UINT#2.

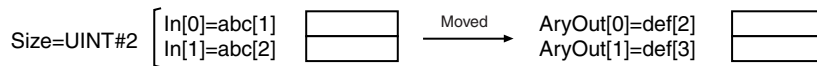
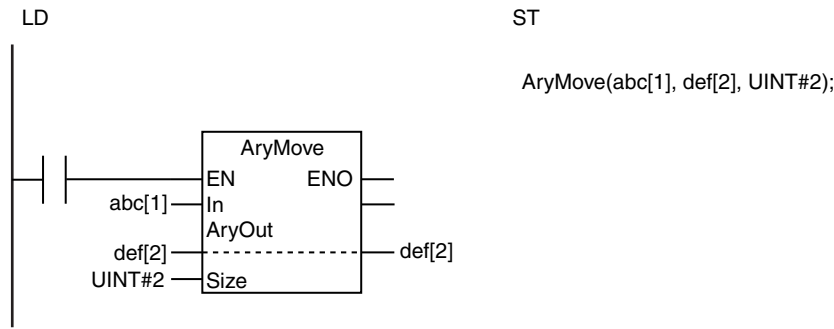

Additional Information

- If the data types of *In[]* and *AryOut[]* are the same, the MemCopy instruction is faster.
- You can specify the same array for *In[]* and *AryOut[]*. Also, the move source and destination data can overlap. The following example is for when *In[0]* is *A[2]*, *AryOut[0]* is *A[4]*, and *Size* is UINT#3.

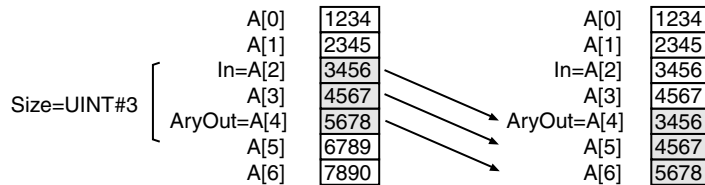

Precautions for Correct Use

- The data types of *In[]* and *AryOut[]* can be different as long as they are both in one of the following groups. The valid range of *AryOut[]* must include the valid range of *In[]*.
 - BYTE, WORD, DWORD, and LWORD
 - USINT, UINT, UDINT, ULINT, SINT, INT, DINT, LINT, REAL, and LREAL
- If *In[]* is an array of structures, use the same data types for *In[]* and *AryOut[]*.
- If the value of *Size* is 0, the value of *Out* will be TRUE and *AryOut[]* will not change.
- Return value *Out* is not used when the instruction is used in ST.
- An error occurs in the following case. *ENO* will be FALSE, and *AryOut[]* will not change.
 - The value of *Size* exceeds the size of *In[]* or *AryOut[]*.
 - *In[]* or *AryOut[]* is a STRING array and the length of a text string in an element to move exceeds the size of the element in *AryOut[]*.

Clear

The Clear instruction initializes a variable.

Instruction	Name	FB/FUN	Graphic expression	ST expression
Clear	Initialize	FUN		Clear(InOut);

Variables

Name	Meaning	I/O	Description	Valid range	Unit	Default
InOut	Data to initialize	In-out	Data to initialize	Depends on data type.	---	---
Out	Return value	Output	Always TRUE	TRUE only	---	---

	Boolean	Bit strings					Integers							Real numbers	Times, durations, dates, and text strings					
	BOOL	BYTE	WORD	DWORD	LWORD	USINT	UINT	UDINT	ULINT	SINT	INT	DINT	LINT	REAL	LREAL	TIME	DATE	TOD	DT	STRING
InOut	OK	OK	OK	OK	OK	OK	OK	OK	OK	OK	OK	OK	OK	OK	OK	OK	OK	OK	OK	OK
	An enumeration, array, array element, structure, or structure member can also be specified.																			
Out	OK																			

Function

The Clear instruction initializes the value of data to initialize *InOut*.

If an initial value attribute is set for a variable, the specified initial value is used. If an initial value attribute is not set, the default initial value for the data type of *InOut* is used. If *InOut* is an external variable, the default initial value of the data type of *InOut* is used regardless of the initial value attribute of the global variable for the external variable.

The default values for the data types are given below.

Data type	Default initial value
BOOL	FALSE
BYTE, WORD, DWORD, or LWORD	16#0
USINT, UINT, UDINT, ULINT, SINT, INT, DINT, LINT, REAL, or LREAL	0
TIME	T#0ms
DATE	D#1970-1-1
TOD	TOD#0:0:0
DT	DT#1970-1-1-0:0:0
STRING	"

If *InOut* is an array, array element, structure, or structure member, the following processing is performed.

<i>InOut</i>	Processing
Array	All elements in the array are initialized.
Array element	Only the specified element is initialized.
Structure	All members in the structure are initialized.
Structure member	Only the specified member is initialized.

The following figure shows a programming example. The value of variable *abc* is initialized.

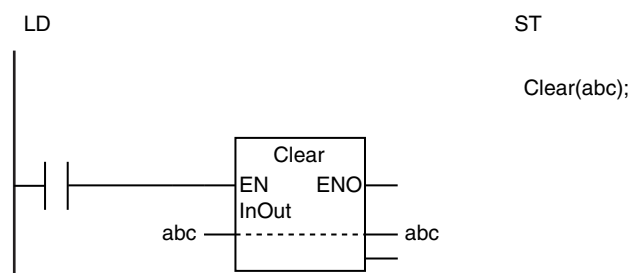

The Clear instruction initializes the value of *InOut*.
The data type of *abc* is INT, so the value of *abc* will be INT#0.

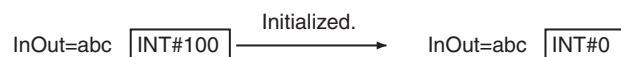

Additional Information

- If *InOut* is an array that is used as a stack, execute this instruction and also set the variable that manages the number of items stored in the stack to 0.
- If you initialize a cam data variable with this instruction, it will not contain the data that was saved with the MC_SaveCamTable instruction. It will contain all zeros.

Precautions for Correct Use

- Return value *Out* is not used when the instruction is used in ST.
- To initialize an enumerated variable, use the Initial Value attribute. If the Initial Value attribute is not set, the value of the enumerated variable will be 0.
- Do not perform processing that meets all of the following conditions. The operation is not reliable.
 - Pass one element of a BOOL array as an in-out variable to a function or function block.
 - Execute the Clear instruction in the function or function block.
 - Use the in-out variable that received the element of the above BOOL array as the parameter to pass to the Clear instruction.

Copy**ToNum (Bit String to Signed Integer)

The Copy**ToNum instruction copies the content of a bit string directly to a signed integer.

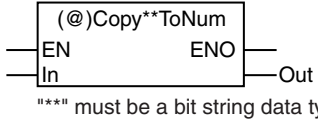
Instruction	Name	FB/FUN	Graphic expression	ST expression
Copy**ToNum	Bit Pattern Copy (Bit String to Signed Integer) Group	FUN		Out:=Copy**ToNum(In); "*** must be a bit string data type.

Variables

Name	Meaning	I/O	Description	Valid range	Unit	Default
In	Copy source	Input	Copy source	Depends on data type.	---	0
Out	Copy destination	Output	Copy destination	Depends on data type.	---	---

	Boolean	Bit strings					Integers							Real numbers	Times, durations, dates, and text strings					
	BOOL	BYTE	WORD	DWORD	LWORD	USINT	UINT	UDINT	ULINT	SINT	INT	DINT	LINT	REAL	LREAL	TIME	DATE	TOD	DT	STRING
In		OK	OK	OK	OK															
Out		Must be a signed integer data type that is the same size as the data type of <i>In</i> .																		

Function

The Copy**ToNum instruction copies the content of copy source *In* directly to copy destination *Out*. There are four instructions depending on the data types of *In* and *Out*.

<i>In</i>	<i>Out</i>	Instruction
BYTE	SINT	CopyByteToNum
WORD	INT	CopyWordToNum
DWORD	DINT	CopyDwordToNum
LWORD	LINT	CopyLwordToNum

The following example for the CopyWordToNum instruction is for when *In* is WORD#16#4D2.

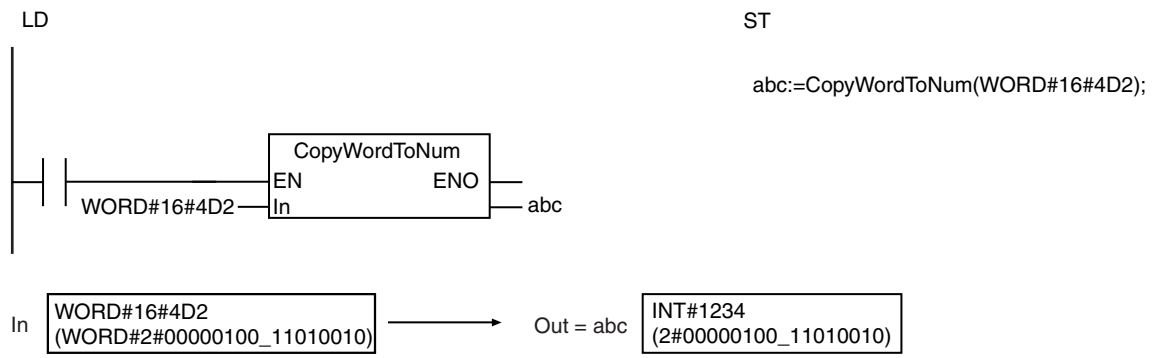

Copy**To*** (Bit String to Real Number)

The Copy**To*** instruction copies the content of a bit string directly to a real number.

Instruction	Name	FB/FUN	Graphic expression	ST expression
Copy**To***	Bit Pattern Copy (Bit String to Real Number) Group	FUN		Out:=CopyDwordToReal(In); or Out:=CopyLwordToLreal(In);

Variables

Name	Meaning	I/O	Description	Valid range	Unit	Default
In	Copy source	Input	Copy source	Depends on data type.	---	0
Out	Copy destination	Output	Copy destination	Depends on data type.	---	---

	Boolean	Bit strings				Integers							Real numbers	Times, durations, dates, and text strings						
	BOOL	BYTE	WORD	DWORD	LWORD	USINT	UINT	UDINT	ULINT	SINT	INT	DINT	LINT	REAL	LREAL	TIME	DATE	TOD	DT	STRING
In				OK	OK															
Out	Must be REAL if the data type of <i>In</i> is DWORD and LREAL if the data type of <i>In</i> is LWORD.																			

Function

The Copy**To*** instruction copies the content of copy source *In* directly to copy destination *Out*. There are two instructions depending on the data types of *In* and *Out*.

<i>In</i>	<i>Out</i>	Instruction
DWORD	REAL	CopyDwordToReal
LWORD	LREAL	CopyLwordToLreal

The following example for the CopyDwordToReal instruction is for when *In* is DWORD#16#40200000.

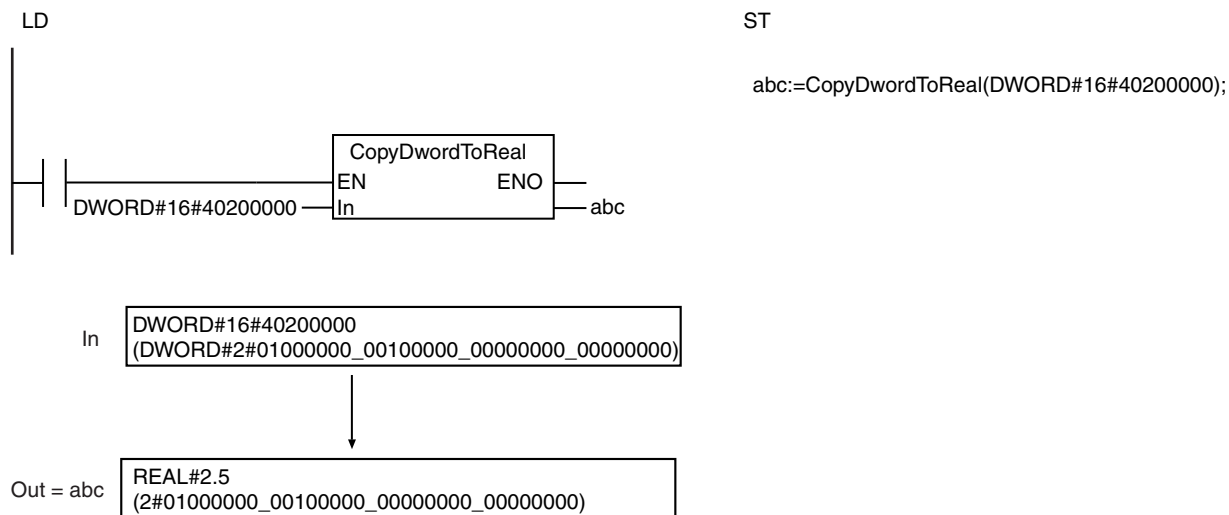

CopyNumTo** (Signed Integer to Bit String)

The CopyNumTo** instruction copies the content of a signed integer directly to a bit string.

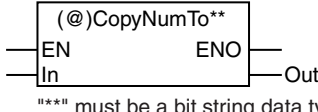
Instruction	Name	FB/FUN	Graphic expression	ST expression
CopyNumTo**	Bit Pattern Copy (Signed Integer to Bit String) Group	FUN		Out:=CopyNumTo**(In); "****" must be a bit string data type.

Variables

Name	Meaning	I/O	Description	Valid range	Unit	Default
In	Copy source	Input	Copy source	Depends on data type.	---	0
Out	Copy destination	Output	Copy destination	Depends on data type.	---	---

	Boolean	Bit strings				Integers							Real numbers	Times, durations, dates, and text strings						
	BOOL	BYTE	WORD	DWORD	LWORD	USINT	UINT	UDINT	ULINT	SINT	INT	DINT	LINT	REAL	LREAL	TIME	DATE	TOD	DT	STRING
In										OK	OK	OK	OK							
Out	Must be a bit string data type that is the same size as the data type of <i>In</i> .																			

Function

The CopyNumTo** instruction copies the content of copy source *In* directly to copy destination *Out*. There are four instructions depending on the data types of *In* and *Out*.

<i>In</i>	<i>Out</i>	Instruction
SINT	BYTE	CopyNumToByte
INT	WORD	CopyNumToWord
DINT	DWORD	CopyNumToDword
LINT	LWORD	CopyNumToLword

The following example for the CopyNumToWord instruction is for when *In* is INT#1234.

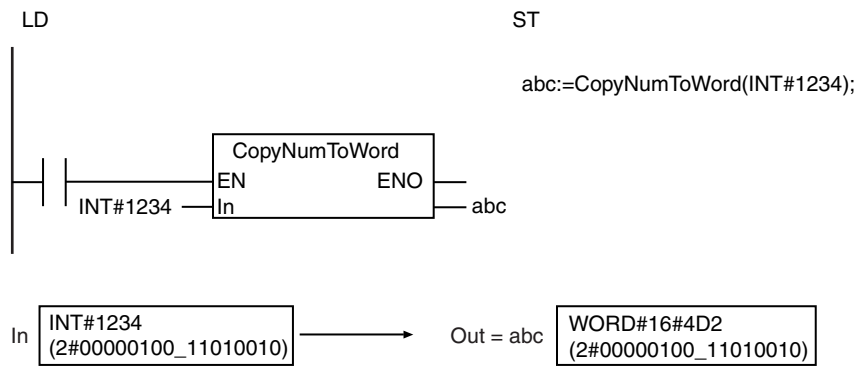

CopyNumTo** (Signed Integer to Real Number)

The CopyNumTo** instruction copies the content of a signed integer directly to a real number.

Instruction	Name	FB/FUN	Graphic expression	ST expression
CopyNumTo**	Bit Pattern Copy (Signed Integer to Real Number) Group	FUN		Out:=CopyNumToReal(In); or Out:=CopyNumToLreal(In);

Variables

Name	Meaning	I/O	Description	Valid range	Unit	Default
In	Copy source	Input	Copy source	Depends on data type.	---	0
Out	Copy destination	Output	Copy destination	Depends on data type.	---	---

	Boolean	Bit strings					Integers							Real numbers		Times, durations, dates, and text strings				
	BOOL	BYTE	WORD	DWORD	LWORD	USINT	UINT	UDINT	ULINT	SINT	INT	DINT	LINT	REAL	LREAL	TIME	DATE	TOD	DT	STRING
In												OK	OK							
Out	Must be REAL if the data type of <i>In</i> is DINT and LREAL if the data type of <i>In</i> is LINT.																			

Function

The CopyNumTo** instruction copies the content of copy source *In* directly to copy destination *Out*. There are two instructions depending on the data types of *In* and *Out*.

<i>In</i>	<i>Out</i>	Instruction
DINT	REAL	CopyNumToReal
LINT	LREAL	CopyNumToLreal

The following example for the CopyNumToReal instruction is for when *In* is DINT#1075838976.

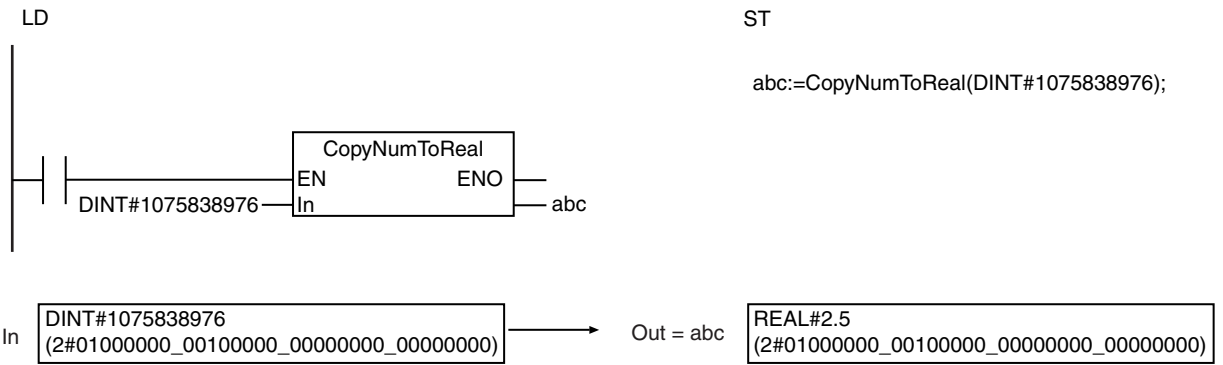

Copy**To*** (Real Number to Bit String)

The Copy**To*** instruction copies the content of a real number directly to a bit string.

Instruction	Name	FB/FUN	Graphic expression	ST expression
Copy**To***	Bit Pattern Copy (Real Number to Bit String) Group	FUN		Out:=CopyRealToDword(In); or Out:=CopyLrealToLword(In);

Variables

Name	Meaning	I/O	Description	Valid range	Unit	Default
In	Copy source	Input	Copy source	Depends on data type.	---	0.0
Out	Copy destination	Output	Copy destination	Depends on data type.	---	---

	Boolean	Bit strings				Integers							Real numbers		Times, durations, dates, and text strings					
	BOOL	BYTE	WORD	DWORD	LWORD	USINT	UINT	UDINT	ULINT	SINT	INT	DINT	LINT	REAL	LREAL	TIME	DATE	TOD	DT	STRING
In														OK	OK					
Out	Must be DWORD if the data type of <i>In</i> is REAL and LWORD if the data type of <i>In</i> is LREAL.																			

Function

The Copy**To*** instruction copies the content of copy source *In* directly to copy destination *Out*. There are two instructions depending on the data types of *In* and *Out*.

<i>In</i>	<i>Out</i>	Instruction
REAL	DWORD	CopyRealToDword
LREAL	LWORD	CopyLrealToLword

The following example for the CopyRealToDword instruction is for when *In* is REAL#2.5.

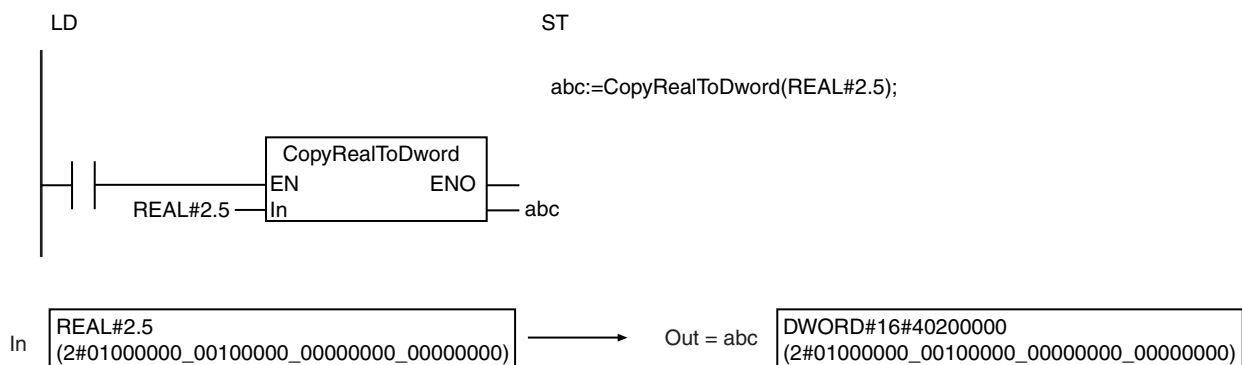

Copy**ToNum (Real Number to Signed Integer)

The Copy**ToNum instruction copies the content of a real number directly to a signed integer.

Instruction	Name	FB/FUN	Graphic expression	ST expression
Copy**ToNum	Bit Pattern Copy (Real Number to Signed Integer) Group	FUN		Out:=CopyRealToNum(In); or Out:=CopyLrealToNum(In);

Variables

Name	Meaning	I/O	Description	Valid range	Unit	Default
In	Copy source	Input	Copy source	Depends on data type.	---	0.0
Out	Copy destination	Output	Copy destination	Depends on data type.	---	---

	Boolean	Bit strings					Integers							Real numbers		Times, durations, dates, and text strings				
	BOOL	BYTE	WORD	DWORD	LWORD	USINT	UINT	UDINT	ULINT	SINT	INT	DINT	LINT	REAL	LREAL	TIME	DATE	TOD	DT	STRING
In														OK	OK					
Out	Must be DINT if the data type of <i>In</i> is REAL and LINT if the data type of <i>In</i> is LREAL.																			

Function

The Copy**ToNum instruction copies the content of copy source *In* directly to copy destination *Out*. There are two instructions depending on the data types of *In* and *Out*.

<i>In</i>	<i>Out</i>	Instruction
REAL	DINT	CopyRealToNum
LREAL	LINT	CopyLrealToNum

The following example for the CopyRealToNum instruction is for when *In* is REAL#2.5.

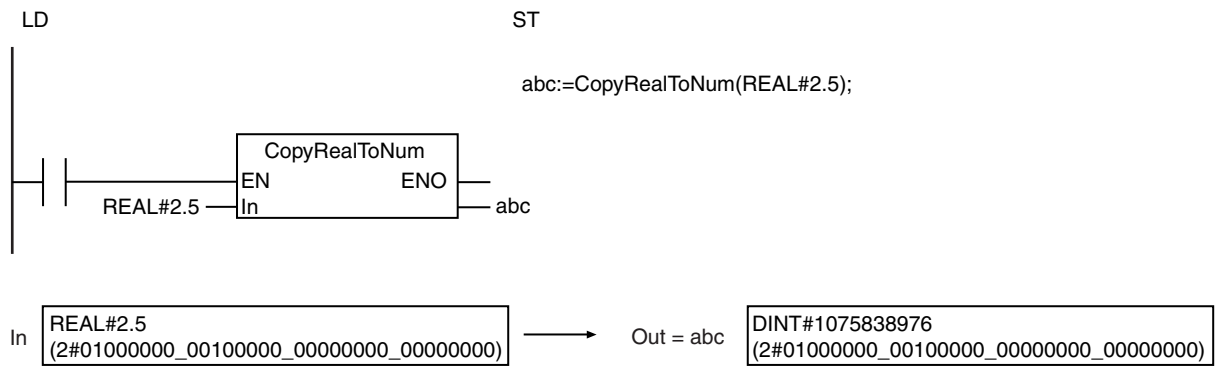

Shift Instructions

Instruction	Name	Page
AryShiftReg	Shift Register	2-388
AryShiftRegLR	Reversible Shift Register	2-390
ArySHL and ArySHR	Array N-element Left Shift/ Array N-element Right Shift	2-393
SHL and SHR	N-bit Left Shift/ N-bit Right Shift	2-396
NSHLC and NSHRC	Shift N-bits Left with Carry/ Shift N-bits Right with Carry	2-398
ROL and ROR	Rotate N-bits Left/ Rotate N-bits Right	2-400

AryShiftReg

The AryShiftReg instruction shifts a shift register one bit to the left and inserts the input value to the least-significant bit. The shift register consists of array elements.

Instruction	Name	FB/FUN	Graphic expression	ST expression
AryShiftReg	Shift Register	FB	<pre> graph LR AryShiftReg_instance[AryShiftReg_instance] Shift --> AryShiftReg_instance Reset --> AryShiftReg_instance In --> AryShiftReg_instance InOut --> AryShiftReg_instance Size --> AryShiftReg_instance AryShiftReg_instance --> ENO </pre>	AryShiftReg_instance(Shift, Reset, In, InOut, Size);

Variables

Name	Meaning	I/O	Description	Valid range	Unit	Default
Shift	Shift	Input	Shifted when signal changes to TRUE.	Depends on data type.	---	FALSE
Reset	Reset		TRUE: Register is reset.			
In	Input value		Value to insert to least-significant bit of <i>InOut[]</i> .			
Size	Number of elements in array of bit strings		Number of elements to use as a shift register in <i>InOut[]</i> .			
InOut[] (array)	Array of bit strings	In-out	Array of bit strings	Depends on data type.	---	---

	Boolean	Bit strings					Integers							Real numbers		Times, durations, dates, and text strings				
	BOOL	BYTE	WORD	DWORD	LWORD	USINT	UINT	UDINT	ULINT	SINT	INT	DINT	LINT	REAL	LREAL	TIME	DATE	TOD	DT	STRING
Shift	OK																			
Reset	OK																			
In	OK																			
Size							OK													
InOut[] (array)	OK	OK	OK	OK	OK															

Function

The AryShiftReg instruction shifts *Size* array elements in the array of bit strings *InOut[]* to the left (i.e., toward most-significant bit) when *Shift* changes to TRUE. The shift operation starts from *InOut[0]*. Input value *In* is inserted to the least-significant bit. The most-significant bit of the array of bit strings is output to the Carry (CY) Flag (P_CY).

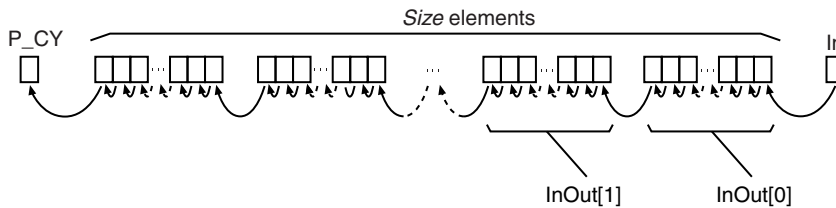

When Reset is TRUE, CY and all of bits in *Size* elements starting from *InOut[0]* are set to FALSE.

The following example is for when *InOut[]* is a BYTE array and *Size* is UINT#2.

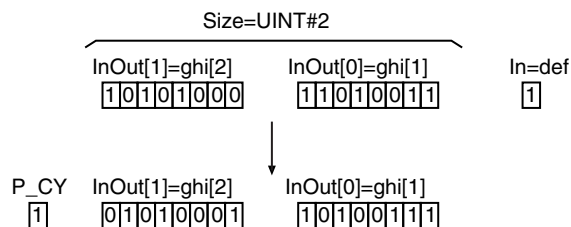
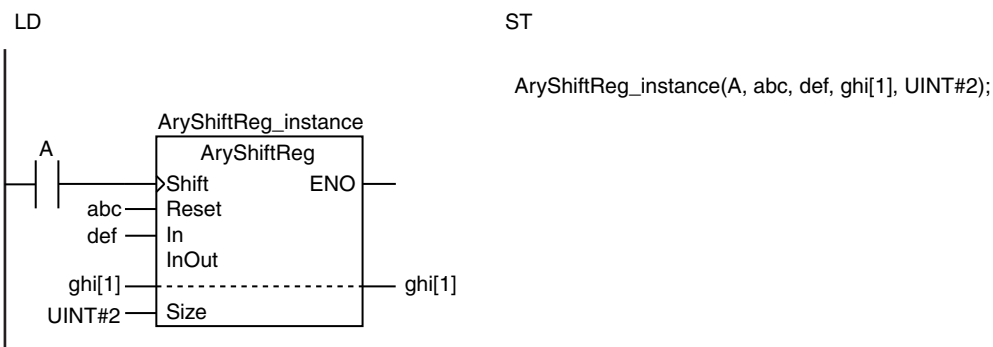

Related System-defined Variables

Name	Meaning	Data type	Description
P_CY	Carry (CY) Flag	BOOL	Value stored in Carry Flag

Precautions for Correct Use

- While *Reset* is TRUE, the register is not shifted even if *Shift* changes to TRUE.
- *ENO* will change to TRUE when *Shift* changes to TRUE and the shift operation is performed normally, or when *Reset* is TRUE and the reset operation is performed normally.
- The *InOut[]* does not change if the value of *Size* is 0.
- An error occurs in the following case. *ENO* will be FALSE, and *InOut[]* will not change.
 - The value of *Size* exceeds the array area of *InOut[]*.

AryShiftRegLR

The AryShiftRegLR instruction shifts a bit string one bit to the left or right and inserts the input value to the least-significant or most-significant bit. The bit string consists of array elements.

Instruction	Name	FB/FUN	Graphic expression	ST expression
AryShiftRegLR	Reversible Shift Register	FB		AryShiftRegLR_instance (ShiftL, ShiftR, Reset, In, InOut, Size);

Variables

Name	Meaning	I/O	Description	Valid range	Unit	Default
ShiftL	Left shift	Input	Shifted left when signal changes to TRUE.	Depends on data type.	---	FALSE
ShiftR	Right shift		Shifted right when signal changes to TRUE.			
Reset	Reset		TRUE: Register is reset.			
In	Input value		Value to insert to least-significant or most-significant bit of <i>InOut[]</i>			
Size	Number of elements in array of bit strings		Number of elements to use as a shift register in <i>InOut[]</i> .			1
InOut[] (array)	Array of bit strings	In-out	Array of bit strings	Depends on data type.	---	---

	Boolean	Bit strings					Integers							Real numbers		Times, durations, dates, and text strings				
	BOOL	BYTE	WORD	DWORD	LWORD	USINT	UINT	UDINT	ULINT	SINT	INT	DINT	LINT	REAL	LREAL	TIME	DATE	TOD	DT	STRING
ShiftL	OK																			
ShiftR	OK																			
Reset	OK																			
In	OK																			
Size							OK													
InOut[] (array)	OK	OK	OK	OK	OK															

Function

The AryShiftRegLR instruction shifts *Size* array elements of array of bit strings *InOut[]* to the left when *ShiftL* changes to TRUE. The shift operation starts from *InOut[0]*. Input value *In* is inserted to the least-significant bit. The most-significant bit of the array of bit strings is output to the Carry (CY) Flag (P_CY).

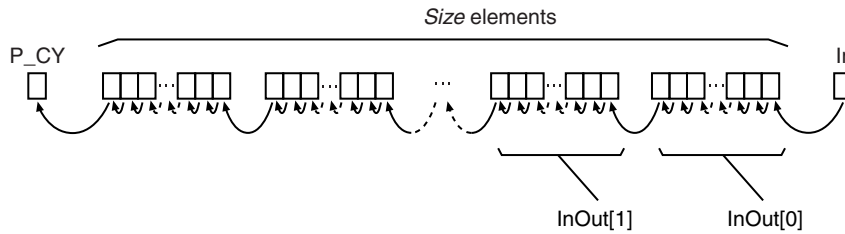

When *ShiftR* changes to TRUE, the bits are shifted one bit to the right and *In* is inserted to the most-significant bit. The least-significant bit of the array of bit strings is output to the Carry (CY) Flag (P_CY).

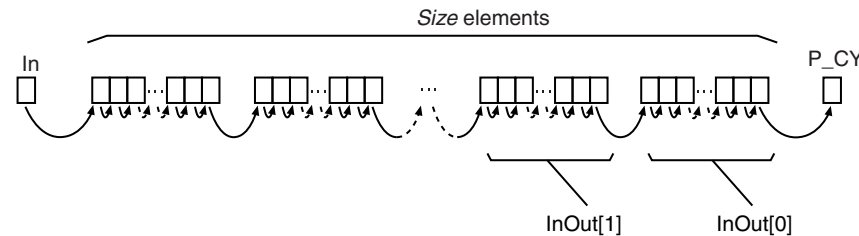

When *Reset* is TRUE, P_CY and all of the bits in *Size* elements starting from *InOut[0]* are set to FALSE.

The following example is for when *InOut* is BYTE data, *Size* is UINT#2 and *ShiftL* changes to TRUE.

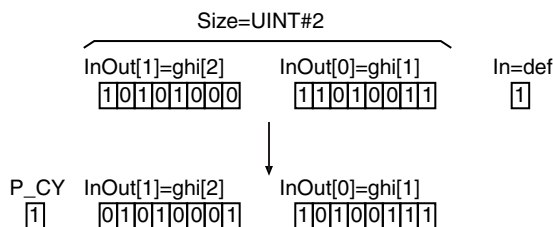
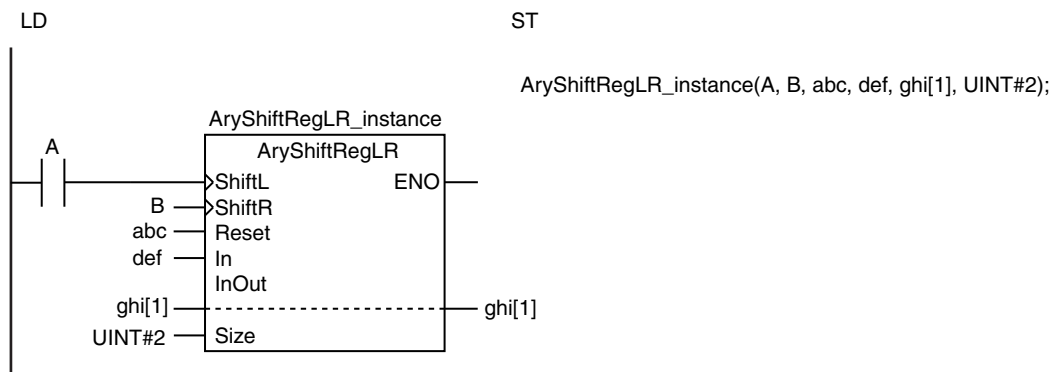

Related System-defined Variables

Name	Meaning	Data type	Description
P_CY	Carry (CY) Flag	BOOL	Value stored in Carry Flag

Precautions for Correct Use

- While *Reset* is TRUE, the register is not shifted even if *ShiftL* or *ShiftR* changes to TRUE.
- The register is not shifted if both *ShiftL* and *ShiftR* change to TRUE at the same time.
- *ENO* will change to TRUE when *ShiftL* or *ShiftR* changes to TRUE and the shift operation is performed normally, or when *Reset* is TRUE and the reset operation is performed normally.
- The *InOut[]* does not change if the value of *Size* is 0.
- An error occurs in the following case. *ENO* will be FALSE, and *InOut[]* will not change.
 - The value of *Size* exceeds the array area of *InOut[]*.

ArySHL and ArySHR

These instructions shift array elements by one or more elements.

ArySHL: Shifts the array to the left (toward the higher elements).

ArySHR: Shifts the array to the right (toward the lower elements).

Instruction	Name	FB/FUN	Graphic expression	ST expression
ArySHL	Array N-element Left Shift	FUN		ArySHL(InOut, Size, Num);
ArySHR	Array N-element Right Shift	FUN		ArySHR(InOut, Size, Num);

Variables

Name	Meaning	I/O	Description	Valid range	Unit	Default
Size	Number of elements in shift register	Input	Number of elements in shift register	Depends on data type.	---	1
Num	Number of elements to shift		Number of elements to shift			
InOut[] (array)	Shift register array	In-out	Shift register array	Depends on data type.	---	---
Out	Return value	Output	Always TRUE	TRUE only	---	---

	Boolean	Bit strings				Integers							Real numbers		Times, durations, dates, and text strings					
	BOOL	BYTE	WORD	DWORD	LWORD	USINT	UINT	UDINT	ULINT	SINT	INT	DINT	LINT	REAL	LREAL	TIME	DATE	TOD	DT	STRING
Size						OK														
Num						OK														
InOut[] (array)	OK	OK	OK	OK	OK	OK	OK	OK	OK	OK	OK	OK	OK	OK	OK	OK	OK	OK	OK	OK
	Arrays of structures can also be specified.																			
Out	OK																			

Function

These instructions shift the upper *Size* elements in shift register array *InOut[]* by *Num* elements. The values that are shifted out of the array are discarded.

The default initial value for the data type of *InOut[]* is stored in the empty elements.

If *InOut[]* is an array of structures, the members of the structures in all elements are initialized.

The default values for the data types are given below.

Data type of <i>InOut</i>	Default
BOOL	FALSE
BYTE, WORD, DWORD, or LWORD	16#0
USINT, UINT, UDINT, ULINT, SINT, INT, DINT, LINT, REAL, or LREAL	0
TIME	T#0ms
DATE	D#1970-1-1
TOD	TOD#0:0:0
DT	DT#1970-1-1-0:0:0
STRING	"

● ArySHL

The ArySHL instruction shifts the array to the left (toward the higher elements of the array).

● ArySHR

The ArySHR instruction shifts the array to the right (toward the lower elements of the array).

The following example shows the ArySHL instruction when *Size* is *UINT#6* and *Num* is *UINT#2*.

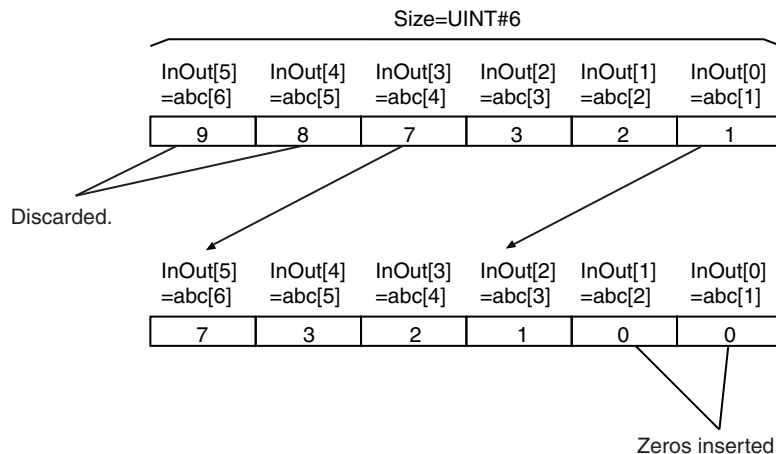
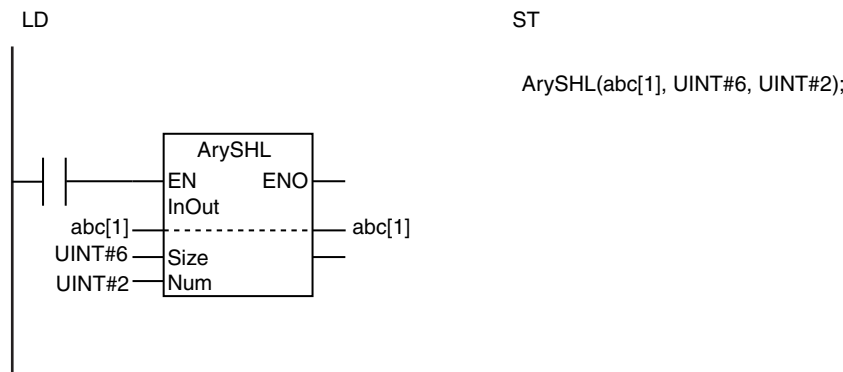

Additional Information

If *InOut[]* is BOOL data, the results will be the same as shifting a bit string of *Size* bits by *Num* bits.

Precautions for Correct Use

- The shift operation is not performed if the value of *Num* is 0.
- If the value of *Num* is larger than *Size*, all values from *InOut[0]* to *InOut[Size-1]* are initialized.
- Return value *Out* is not used when the instruction is used in ST.
- An error occurs in the following case. *ENO* will be FALSE, and *InOut[]* will not change.
 - The value of *Size* exceeds the array area of *InOut[]*.

SHL and SHR

These instructions shift a bit string by one or more bits.

SHL: Shifts the bit string to the left (toward the higher bits).

SHR: Shifts the bit string to the right (toward the lower bits).

Instruction	Name	FB/FUN	Graphic expression	ST expression
SHL	N-bit Left Shift	FUN		Out:=SHL(In, Num);
SHR	N-bit Right Shift	FUN		Out:=SHR(In, Num);

Variables

Name	Meaning	I/O	Description	Valid range	Unit	Default
In	Data to shift	Input	Data to shift	Depends on data type.	---	*1
Num*2	Number to shift		Number of bits to shift	0 to No. of bits in <i>In</i>	Bits	1
Out	Processing result	Output	Processing result	Depends on data type.	---	---

*1 If you omit the input parameter, the default value is not applied. A building error will occur.

*2 On Sysmac Studio version 1.03, you can use "N" instead of "Num" to more clearly show the correspondence between the variables and the parameter names in ST expressions. For example, you can use the following notation:
 Out:=SHL(In:=BYTE#16#89, N:=ULINT#2);

	Boolean	Bit strings					Integers							Real numbers		Times, durations, dates, and text strings				
	BOOL	BYTE	WORD	DWORD	LWORD	USINT	UINT	UDINT	ULINT	SINT	INT	DINT	LINT	REAL	LREAL	TIME	DATE	TOD	DT	STRING
In		OK	OK	OK	OK															
Num						OK*			OK*											
Out	Must be same data type as <i>In</i>																			

* With a CPU Unit with unit version 1.02 or later and Sysmac Studio version 1.03 or higher, use a ULINT variable. With a CPU Unit with unit version 1.01 or earlier and Sysmac Studio version 1.02 or lower, use a USINT variable.

Function

These instructions shift data to shift *In* (bit string data) by the number of bits specified in number to shift *Num*. The bits that are shifted out of the register are discarded and zeros are inserted into the other end of the register.

● SHL

The SHL instruction shifts bits from right to left (from least-significant to most-significant bits). The following example is for when *In* is BYTE#16#89 and *Num* is ULINT#2.

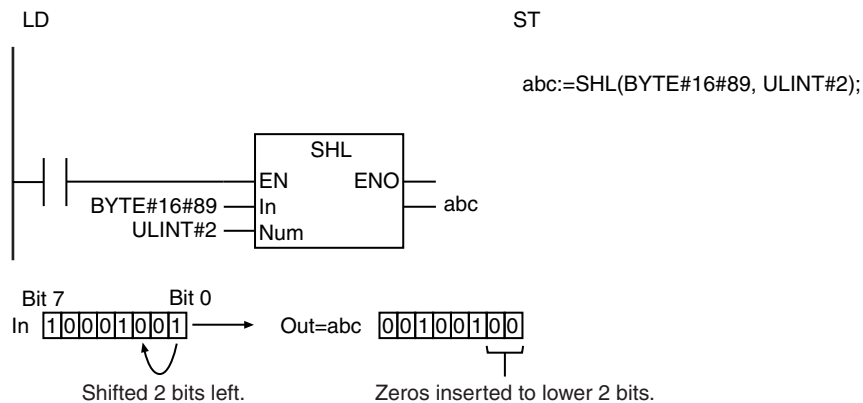

● SHR

The SHR instruction shifts bits from left to right (from most-significant to least-significant bits). The following example is for when *In* is BYTE#16#89 and *Num* is ULINT#2.

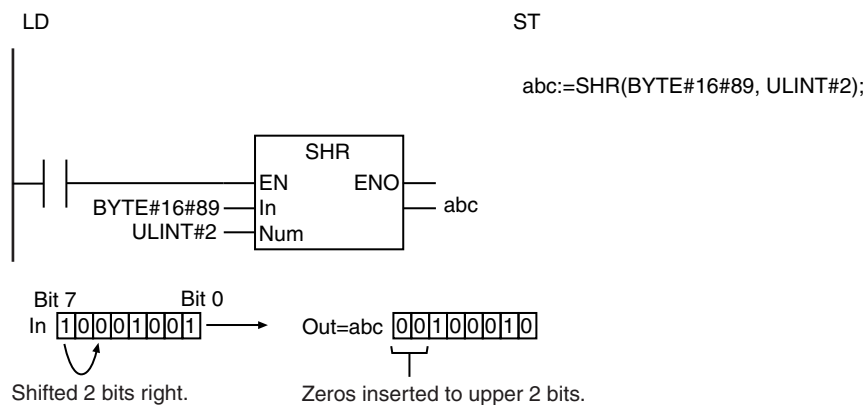

Additional Information

The ROL and ROR instructions insert the bits that are shifted out of the register into the other end of the register.

Precautions for Correct Use

- The data types of *In* and *Out* must be the same.
- If *Num* is 0, an error will not occur and the value of *In* will be assigned directly to *Out*.
- If the value of *Num* exceeds the number of bits specified in *In*, an error will not occur and the value of *Out* will be 16#0.

NSHLC and NSHRC

These instructions shift an array of bit strings by one or more bits. The Carry (CY) Flag is included.

NSHLC: Shifts the array to the left (toward the higher elements).

NSHRC: Shifts the array to the right (toward the lower elements).

Instruction	Name	FB/FUN	Graphic expression	ST expression
NSHLC	Shift N-bits Left with Carry	FUN		NSHLC(InOut, Size, Num);
NSHRC	Shift N-bits Right with Carry	FUN		NSHRC(InOut, Size, Num);

Variables

Name	Meaning	I/O	Description	Valid range	Unit	Default
Size	Number of bits in shift register	Input	Number of bits in shift register	Depends on data type.	Bits	1
Num	Number of bits to shift		Number of bits to shift			
InOut[] (array)	Shift register array	In-out	Bit string array to shift	Depends on data type.	---	---
Out	Return value	Output	Always TRUE	TRUE only	---	---

	Boolean	Bit strings					Integers							Real numbers		Times, durations, dates, and text strings				
	BOOL	BYTE	WORD	DWORD	LWORD	USINT	UINT	UDINT	ULINT	SINT	INT	DINT	LINT	REAL	LREAL	TIME	DATE	TOD	DT	STRING
Size						OK														
Num						OK														
InOut[] (array)	OK	OK	OK	OK	OK															
Out	OK																			

Function

These instructions shift *Size* array elements in shift register array *InOut[]* by the number of bits specified in *Num*. The shift register starts at *InOut[0]*. The last bit that is shifted out of the register is output to the Carry (CY) Flag. Zeros are inserted for the bits at the other end.

● NSHLC

The NSHLC instruction shifts bits from the lower elements in the array to the higher elements and from the least-significant bits to the most-significant bits.

● NSHRC

The NSHRC instruction shifts bits from the higher elements in the array to the lower elements and from the most-significant bits to the least-significant bits.

The following example shows the NSHLC instruction when *InOut[]* is a BYTE array, *Size* is USINT#80 and *Num* is USINT#3.

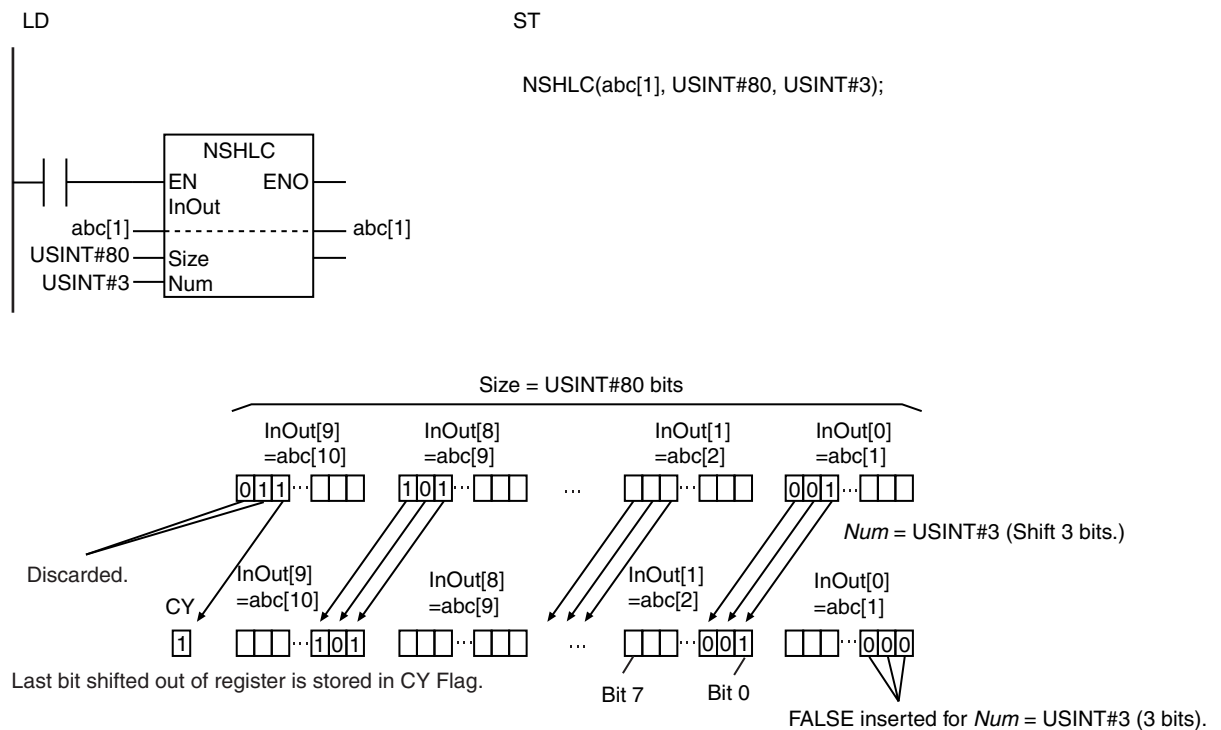

Related System-defined Variables

Name	Meaning	Data type	Description
P_CY	Carry (CY) Flag	BOOL	Value stored in Carry Flag

Precautions for Correct Use

- The shift operation is not performed if the value of *Num* is 0.
- If the value of *Num* is larger than *Size*, *Size* bits from bit 0 of *InOut[0]* are changed to FALSE. The value of the Carry Flag (CY) changes to FALSE.
- Return value *Out* is not used when the instruction is used in ST.
- An error occurs in the following case. *ENO* will be FALSE, and *InOut[]* will not change.
 - The value of *Size* exceeds the array area of *InOut[]*.

ROL and ROR

These instructions rotate a bit string by one or more bits.

ROL: Rotates the bit string to the left (toward the higher bits).

ROR: Rotates the bit string to the right (toward the lower bits).

Instruction	Name	FB/FUN	Graphic expression	ST expression
ROL	Rotate N-bits Left	FUN		Out:=ROL(In, Num);
ROR	Rotate N-bits Right	FUN		Out:=ROR(In, Num);

Variables

Name	Meaning	I/O	Description	Valid range	Unit	Default
In	Data to rotate	Input	Data to rotate	Depends on data type.	---	*1
Num*2	Number of bits		Number of bits to rotate	0 to No. of bits in <i>In</i>	Bits	1
Out	Processing result	Output	Processing result	Depends on data type.	---	---

*1 If you omit the input parameter, the default value is not applied. A building error will occur.

*2 On Sysmac Studio version 1.03, you can use "N" instead of "Num" to more clearly show the correspondence between the variables and the parameter names in ST expressions. For example, you can use the following notation:
Out:=ROL(In:=BYTE#16#89, N:=ULINT#2);

	Boolean	Bit strings					Integers							Real numbers		Times, durations, dates, and text strings				
	BOOL	BYTE	WORD	DWORD	LWORD	USINT	UINT	UDINT	ULINT	SINT	INT	DINT	LINT	REAL	LREAL	TIME	DATE	TOD	DT	STRING
In		OK	OK	OK	OK															
Num						OK*			OK*											
Out	Must be same data type as <i>In</i>																			

* With a CPU Unit with unit version 1.02 or later and Sysmac Studio version 1.03 or higher, use a ULINT variable. With a CPU Unit with unit version 1.01 or earlier and Sysmac Studio version 1.02 or lower, use a USINT variable.

Function

These instructions rotate data to rotate *In* (bit string data) by the number of bits specified in number of bits *Num*. Bits that are shifted out of the register are inserted into the other end of the register.

● ROL

The ROL instruction rotates bits from right to left (from least-significant to most-significant bits). The following example is for when *In* is BYTE#16#89 and *Num* is ULINT#2.

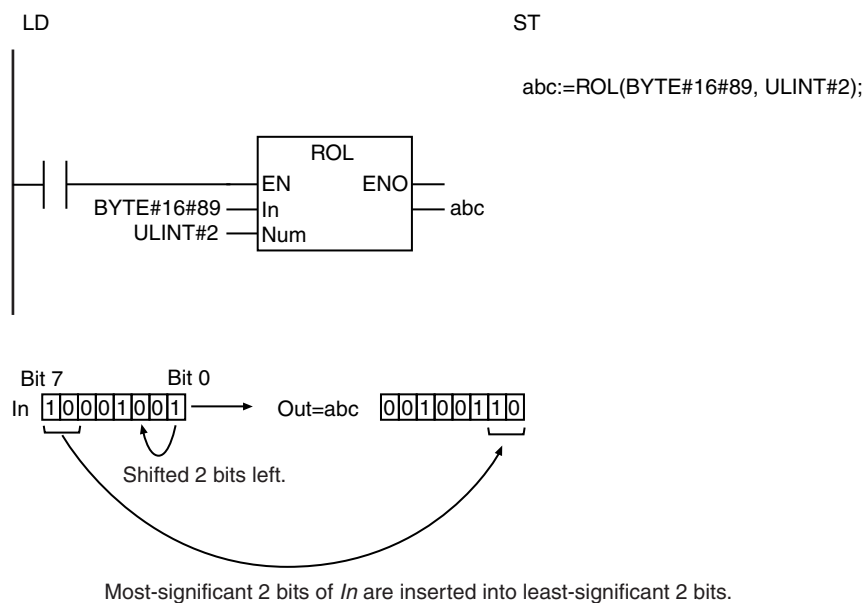

● ROR

The ROR instruction rotates bits from left to right (from most-significant to least-significant bits). The following example is for when *In* is BYTE#16#89 and *Num* is ULINT#2.

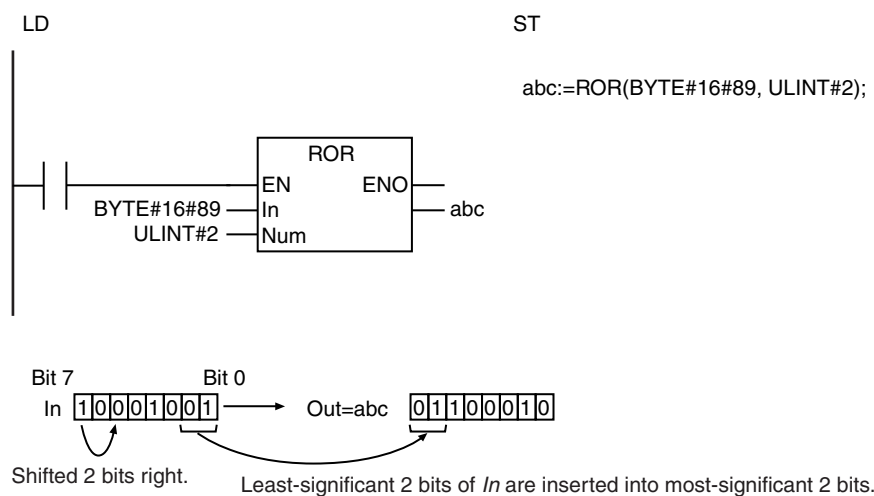

Additional Information

The SHL and SHR instructions discard the bits that are shifted out of the register and insert zeros into the other end of the register.

Precautions for Correct Use

- The data types of *In* and *Out* must be the same.
- If *Num* is 0, an error will not occur and the value of *In* will be assigned directly to *Out*.
- If the value of *Num* exceeds the number of bits specified in *In*, an error will not occur and the bits will be rotated by the number of bits specified in *Num*. For example, if *In* is WORD data, the value of *Out* will be the same regardless of whether the value of *Num* is USINT#1 or USINT#17.

Conversion Instructions

Instruction	Name	Page	Instruction	Name	Page
Swap	Swap Bytes	2-404	FixNumToString	Fixed-decimal Number-to-Text String Conversion	2-451
Neg	Reverse Sign	2-405	StringToFixNum	Text String-to-Fixed-decimal Conversion	2-453
Decoder	Bit Decoder	2-407	DtToString	Date and Time-to-Text String Conversion	2-456
Encoder	Bit Encoder	2-410	DateToString	Date-to-Text String Conversion	2-458
BitCnt	Bit Counter	2-412	TodToString	Time of Day-to-Text String Conversion	2-459
ColmToLine_**	Column to Line Conversion Group	2-413	GrayToBin_** and BinToGray_**	Gray Code-to-Binary Code Conversion Group/ Binary Code-to-Gray Code Conversion	2-461
LineToColm	Line to Column Conversion	2-415	StringToAry	Text String-to-Array Conversion	2-463
Gray	Gray Code Conversion	2-417	AryToString	Array-to-Text String Conversion	2-465
UTF8ToSJIS	UTF-8 to SJIS Character Code Conversion	2-422	DispartDigit	Four-bit Separation	2-467
SJISToUTF8	SJIS to UTF-8 Character Code Conversion	2-424	UniteDigit_**	Four-bit Join Group	2-469
PWLApprox and PWLApproxNo-LineChk	Broken Line Approximation with Broken Line Data Check and Broken Line Approximation without Broken Line Data Check	2-426	Dispart8Bit	Byte Data Separation	2-471
PWLLineChk	Broken Line Data Check	2-432	Unite8Bit_**	Byte Data Join Group	2-473
MovingAverage	Moving Average	2-435	ToAryByte	Conversion to Byte Array	2-475
DispartReal	Separate Mantissa and Exponent	2-441	AryByteTo	Conversion from Byte Array	2-480
UniteReal	Combine Real Number Mantissa and Exponent	2-444	SizeOfAry	Get Number of Array Elements	2-485
NumToDecString and NumToHexString	Fixed-length Decimal Text String Conversion/ Fixed-length Hexadecimal Text String Conversion	2-446	PackWord	2-byte Join	2-487
HexStringToNum_**	Hexadecimal Text String-to-Number Conversion Group	2-449	PackDword	4-byte Join	2-489

Swap

The Swap instruction swaps the upper byte and lower byte of a 16-bit value.

Instruction	Name	FB/FUN	Graphic expression	ST expression
Swap	Swap Bytes	FUN		Out:=Swap(In);

Variables

Name	Meaning	I/O	Description	Valid range	Unit	Default
In	Data to convert	Input	Data to convert	Depends on data type.	---	0
Out	Conversion result	Output	Conversion result	Depends on data type.	---	---

	Boolean	Bit strings					Integers							Real numbers	Times, durations, dates, and text strings							
		BOOL	BYTE	WORD	DWORD	LWORD	USINT	UINT	UDINT	ULINT	SINT	INT	DINT		LINT	REAL	LREAL	TIME	DATE	TOD	DT	STRING
In			OK																			
Out			OK																			

Function

The Swap instruction swaps the upper byte and lower byte of data to convert *In* and assigns the result to conversion result *Out*.

The following example is for when *In* is WORD#16#1234.

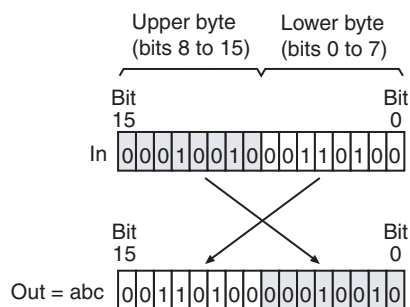
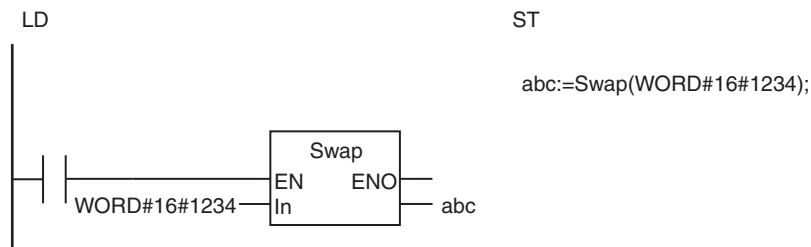

Neg

The Neg instruction reverses the sign of a number.

Instruction	Name	FB/FUN	Graphic expression	ST expression
Neg	Reverse Sign	FUN		Out:=Neg(In);

Variables

Name	Meaning	I/O	Description	Valid range	Unit	Default
In	Data to convert	Input	Data to convert	Depends on data type.	---	*
Out	Conversion result	Output	Conversion result	Depends on data type.	---	---

* If you omit the input parameter, the default value is not applied. A building error will occur.

	Boolean	Bit strings				Integers								Real numbers	Times, durations, dates, and text strings						
		BOOL	BYTE	WORD	DWORD	LWORD	USINT	UINT	UDINT	ULINT	SINT	INT	DINT		LINT	REAL	LREAL	TIME	DATE	TOD	DT
In						OK	OK	OK	OK	OK	OK	OK	OK	OK	OK						
Out						OK	OK	OK	OK	OK	OK	OK	OK	OK	OK						

Function

The Neg instruction reverses the sign of data to convert *In*. The value of *Out* depends on the data type of *In*.

Data type of <i>In</i>	Value of <i>Out</i>
Signed integer: SINT, INT, DINT, or LINT	All bits in <i>In</i> are reversed and then 1 is added. (This is the same as multiplying <i>In</i> by -1 .)
Unsigned integers: USINT, UNIT, UDINT, or ULINT	All bits in <i>In</i> are reversed and then 1 is added.
Real numbers: REAL or LREAL	$In \times (-1)$

The following example is for when *In* is INT#123.

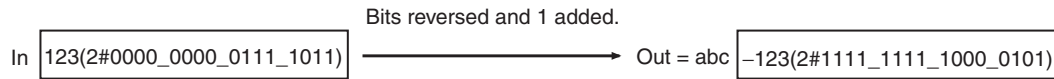
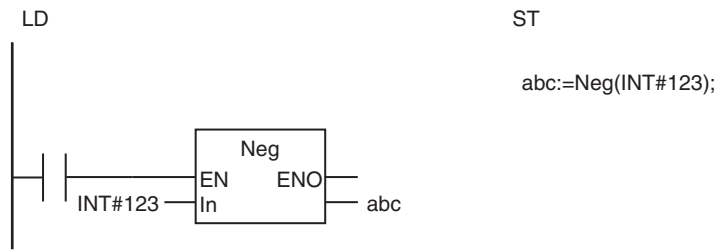

The following example is for when *In* is UINT#123.

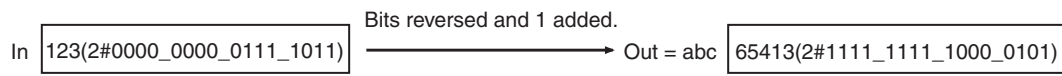

Precautions for Correct Use

If you use a different data type for *In* and *Out*, make sure the valid range of *Out* includes the valid range of *In*. Otherwise, an error will not occur and the value of *Out* will be an illegal value. For example, if the value of *In* is SINT#-128 and the data type of *Out* is INT, the value of *Out* will be INT#-128 instead of INT#128.

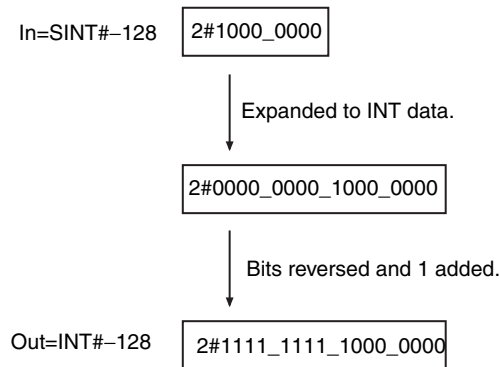

Decoder

The Decoder instruction sets the specified bit to TRUE and the other bits to FALSE in array elements that consist of a maximum of 256 bits.

Instruction	Name	FB/FUN	Graphic expression	ST expression
Decoder	Bit Decoder	FUN		Decoder(In, Size, InOut);

Variables

Name	Meaning	I/O	Description	Valid range	Unit	Default
In	Conversion bit position	Input	Bit position to convert	Depends on data type.	---	0
Size	Bits to convert		Number of bits to convert	0 to 8	Bits	1
InOut[] (array)	Array to convert	In-out	Array to convert	Depends on data type.	---	---
Out	Return value	Output	Always TRUE	TRUE only	---	---

	Boolean	Bit strings				Integers							Real numbers		Times, durations, dates, and text strings					
	BOOL	BYTE	WORD	DWORD	LWORD	USINT	UINT	UDINT	ULINT	SINT	INT	DINT	LINT	REAL	LREAL	TIME	DATE	TOD	DT	STRING
In		OK																		
Size						OK														
InOut[] (array)	OK	OK	OK	OK	OK															
Out	OK																			

Function

The Decoder instruction converts array elements with 2^{Size} bits that start from $InOut[0]$ in array to convert $InOut[]$. It sets the specified bit to TRUE. It sets the other bits to FALSE. The bit to make TRUE is specified by the $Size$ bits in the lower byte of conversion bit position In . Always attach the element number to the in-out parameter that is passed to $InOut[]$, e.g., $array[3]$.

Consider an example where In is BYTE#16#09, $Size$ is USINT#4, and $InOut[]$ is a BYTE array. The value of the $Size$ bits in the lower bits of In is 16#9, which is 9 decimal. Therefore, the ninth bit from the least-significant bit of $InOut[]$ is made TRUE and the other bits are made FALSE.

InOut[] is a BYTE array, so the ninth bit from the least-significant bit is bit 1 in *InOut[1]*. Therefore, bit 1 in *InOut[1]* is made TRUE, all other bits in *InOut[1]* are made FALSE, and all bits in *InOut[0]* are made FALSE.

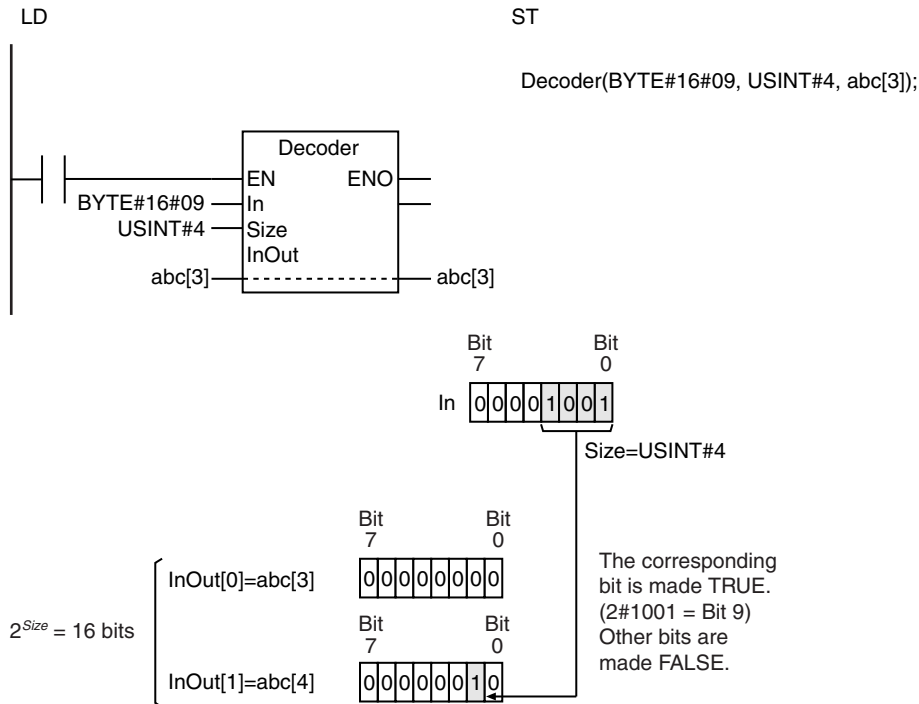

If the number of bits in the elements of *InOut[]* is larger than the number of bits specified by *Size*, the values of the remaining bits are retained. Consider an example where *In* is BYTE#16#02, *Size* is USINT#2, and *InOut[]* is a WORD array.

Size is USINT#2, so the value is set in the lower 4 bits of *InOut[0]*. The values of the remaining bits in *InOut[0]* (bits 4 to 15) are retained.

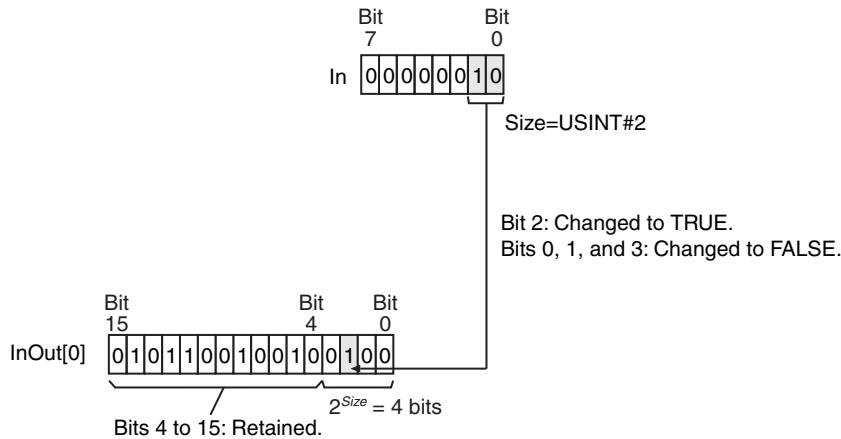

Additional Information

Use the Encoder instruction (page 2-410) to find the position of the highest TRUE bit in array elements that consist of a maximum of 256 bits.

Precautions for Correct Use

- If the value of *Size* is 0, all bits in *InOut[]* change to FALSE.
- Return value *Out* is not used when the instruction is used in ST.
- An error occurs in the following cases. *ENO* will be FALSE, and *InOut[]* will not change.
 - The value of *Size* is outside of the valid range.
 - The value of 2^{Size} exceeds the number of bits in the array elements of *InOut[]*.

Encoder

The Encoder instruction finds the position of the highest TRUE bit in array elements that consist of a maximum of 256 bits.

Instruction	Name	FB/FUN	Graphic expression	ST expression
Encoder	Bit Encoder	FUN		Out:=Encoder(In, Size);

Variables

Name	Meaning	I/O	Description	Valid range	Unit	Default
In[] (array)	Array to convert	Input	Array to convert	Depends on data type.	---	*
Size	Bits to convert		Number of bits to convert	0 to 8	Bits	1
Out	Conversion result	Output	Conversion result	Depends on data type.	---	---

* If you omit the input parameter, the default value is not applied. A building error will occur.

	Boolean	Bit strings					Integers							Real numbers		Times, durations, dates, and text strings				
	BOOL	BYTE	WORD	DWORD	LWORD	USINT	UINT	UDINT	ULINT	SINT	INT	DINT	LINT	REAL	LREAL	TIME	DATE	TOD	DT	STRING
In[] (array)	OK	OK	OK	OK	OK															
Size						OK														
Out		OK																		

Function

The Encoder instruction finds the position of a TRUE bit in a specified range of bits in array to convert *In[]*. The instruction looks for a TRUE bit in 2^{Size} bits from *In[0]*. The position of the TRUE bit in this range is expressed in binary and stored in the *Size* bits in the lower bits of conversion result *Out*. FALSE is stored in the remaining bits of *Out*.

If there is more than one TRUE bit in the specified range, the position of the highest bit that is TRUE is found. Always attach the element number to input parameter that is passed to *In[]*, e.g., *array[3]*.

Consider an example for when *Size* is USINT#4 and *In[]* is a BYTE array. *Size* is USINT#4, so the range in which to find a TRUE bit is 2^4 , or 16 bits, from *In[0]*. In the following diagram, the ninth bit in the range is TRUE.

Size is USINT#4, so 2#1001 (i.e., 9) is stored in the lower 4 bits of *Out*. FALSE is stored in the upper four bits of *Out*.

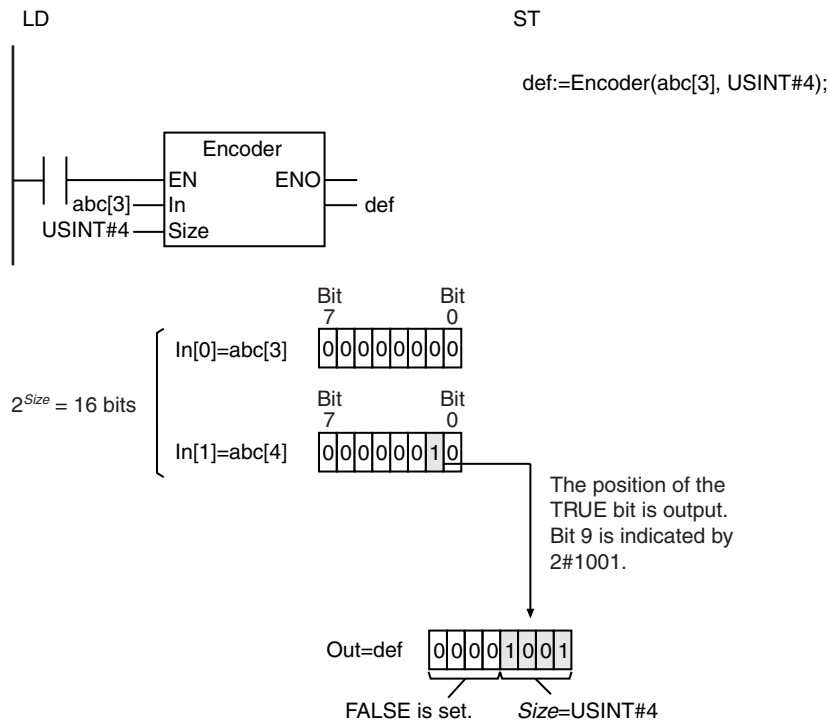

Additional Information

Use the Decoder instruction (page 2-407) to make one bit TRUE and the other bits FALSE in array elements that consist of a maximum of 256 bits.

Precautions for Correct Use

- If the value of *Size* is 0, all bits in *Out* change to FALSE.
- An error occurs in the following cases. *ENO* will be FALSE, and *Out* will not change.
 - The value of *Size* is outside of the valid range.
 - The value of 2^{Size} exceeds the number of bits in the array elements of *In[]*.
 - The value of all bits in *In[]* that are specified by *Size* change to FALSE.

BitCnt

The BitCnt instruction counts the number of TRUE bits in a bit string.

Instruction	Name	FB/FUN	Graphic expression	ST expression
BitCnt	Bit Counter	FUN		Out:=BitCnt(In);

Variables

Name	Meaning	I/O	Description	Valid range	Unit	Default
In	Count string	Input	String in which to count TRUE bits	Depends on data type.	---	*
Out	Count result	Output	Number of TRUE bits	0 to No. of bits in <i>In</i>	---	---

* If you omit the input parameter, the default value is not applied. A building error will occur.

	Boolean	Bit strings					Integers							Real numbers		Times, durations, dates, and text strings				
	BOOL	BYTE	WORD	DWORD	LWORD	USINT	UINT	UDINT	ULINT	SINT	INT	DINT	LINT	REAL	LREAL	TIME	DATE	TOD	DT	STRING
In		OK	OK	OK	OK															
Out						OK														

Function

The BitCnt instruction counts the number of TRUE bits in count string *In*. The following example is for when *In* is BYTE data with a value of BYTE#16#85.

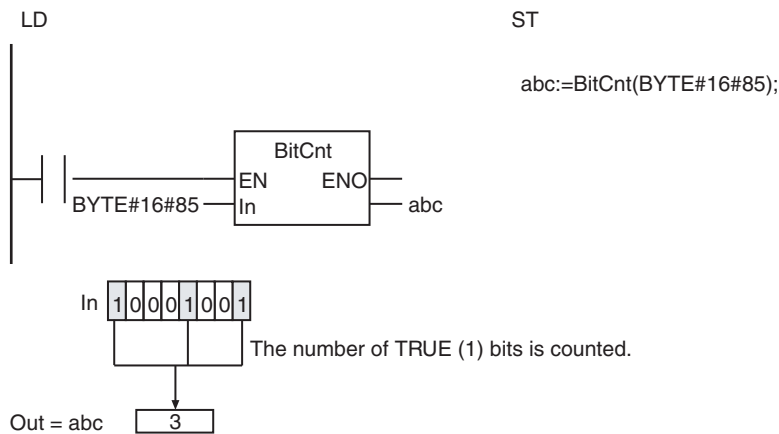

ColmToLine_**

The ColmToLine_** instruction extracts bit values from the specified position of array elements and outputs them as a bit string.

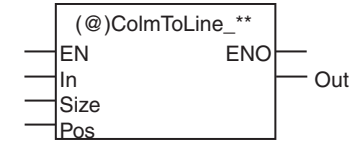
Instruction	Name	FB/FUN	Graphic expression	ST expression
ColmToLine_**	Column to Line Conversion Group	FUN	 <p>*** must be a bit string data type.</p>	Out:=ColmToLine_**(In, Size, Pos); *** must be a bit string data type.

Variables

Name	Meaning	I/O	Description	Valid range	Unit	Default
In[] (array)	Array to convert	Input	Array to convert	Depends on data type.	---	*
Size	Number of elements to convert		Number of elements in <i>In[]</i> to convert	0 to No. of bits in <i>Out</i>		1
Pos	Bit position to convert		Bit position to convert	0 to No. of bits in <i>In[]</i> - 1		0
Out	Conversion result	Output	Conversion result	Depends on data type.	---	---

* If you omit the input parameter, the default value is not applied. A building error will occur.

	Boolean	Bit strings				Integers							Real numbers		Times, durations, dates, and text strings					
	BOOL	BYTE	WORD	DWORD	LWORD	USINT	UINT	UDINT	ULINT	SINT	INT	DINT	LINT	REAL	LREAL	TIME	DATE	TOD	DT	STRING
In[] (array)		OK	OK	OK	OK															
Size						OK														
Pos						OK														
Out		OK	OK	OK	OK															

Function

The ColmToLine_** instruction extracts bit values from the specified position of array elements and outputs them in order as a bit string.

First, *Size* elements are extracted from array to convert *In[]* starting from *In[0]*. Then, only the values of bits in *Pos* are extracted. These are placed in order in a bit string of *Size* bits and stored in conversion result *Out* from the least-significant bit. FALSE is stored in the remaining bits of *Out*.

The name of the instruction is determined by the data type of *Out*. For example, if *Out* is the BYTE data type, the instruction is ColmToLine_BYTE.

Always attach the element number to input parameter that is passed to *In[]*, e.g., *array[3]*.

The following example shows the ColmToLine_BYTE instruction when *Pos* is USINT#3 and *Size* is USINT#4.

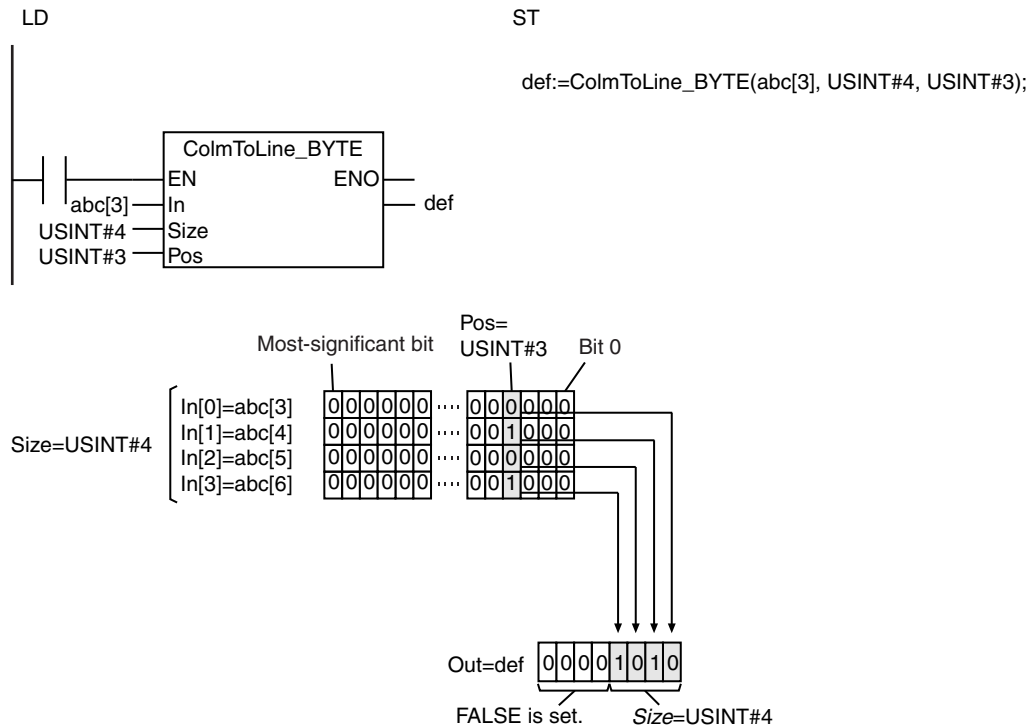

Additional Information

Use the LineToColm instruction (page 2-415) to output a bit string to the specified bit position in array elements.

Precautions for Correct Use

- If the value of *Size* is 0, all bits in *Out* change to FALSE.
- An error occurs in the following cases. *ENO* will be FALSE, and *Out* will not change.
 - The value of *Size* is outside of the valid range.
 - The value of *Pos* is outside of the valid range.
 - The value of *Size* exceeds the array area of *In[]*.

LineToColm

The LineToColm instruction takes the bits from a bit string and outputs them to the specified bit position in array elements.

Instruction	Name	FB/FUN	Graphic expression	ST expression
LineToColm	Line to Column Conversion	FUN		LineToColm(In, InOut, Size, Pos);

Variables

Name	Meaning	I/O	Description	Valid range	Unit	Default
In	Data to convert	Input	Data to convert	Depends on data type.	---	*
Size	Number of elements in result		Number of elements in result	0 to No. of bits in <i>In</i>		1
Pos	Conversion bit position		Bit position to receive the conversion	0 to No. of bits in <i>InOut[] - 1</i>		0
InOut[] (array)	Conversion result array	In-out	Conversion result	Depends on data type.	---	---
Out	Return value	Output	Always TRUE	TRUE only	---	---

* If you omit the input parameter, the default value is not applied. A building error will occur.

	Boolean	Bit strings				Integers							Real numbers		Times, durations, dates, and text strings					
	BOOL	BYTE	WORD	DWORD	LWORD	USINT	UINT	UDINT	ULINT	SINT	INT	DINT	LINT	REAL	LREAL	TIME	DATE	TOD	DT	STRING
In		OK	OK	OK	OK															
Size						OK														
Pos						OK														
InOut[] (array)		OK	OK	OK	OK															
Out	OK																			

Function

The LineToColm instruction takes the bits from a bit string and outputs them to the specified bit position in array elements.

First, *Size* bits are extracted from the least-significant bit of data to convert *In*. These bits are treated individually. Then, the bits are stored in conversion result array *InOut[]* in the *Pos* bit of the elements starting from *InOut[0]*. *Size* specifies the number of array elements to receive bits. The values of all bits for which values are not stored are retained.

The following example is for when *Pos* is USINT#3 and *Size* is USINT#4.

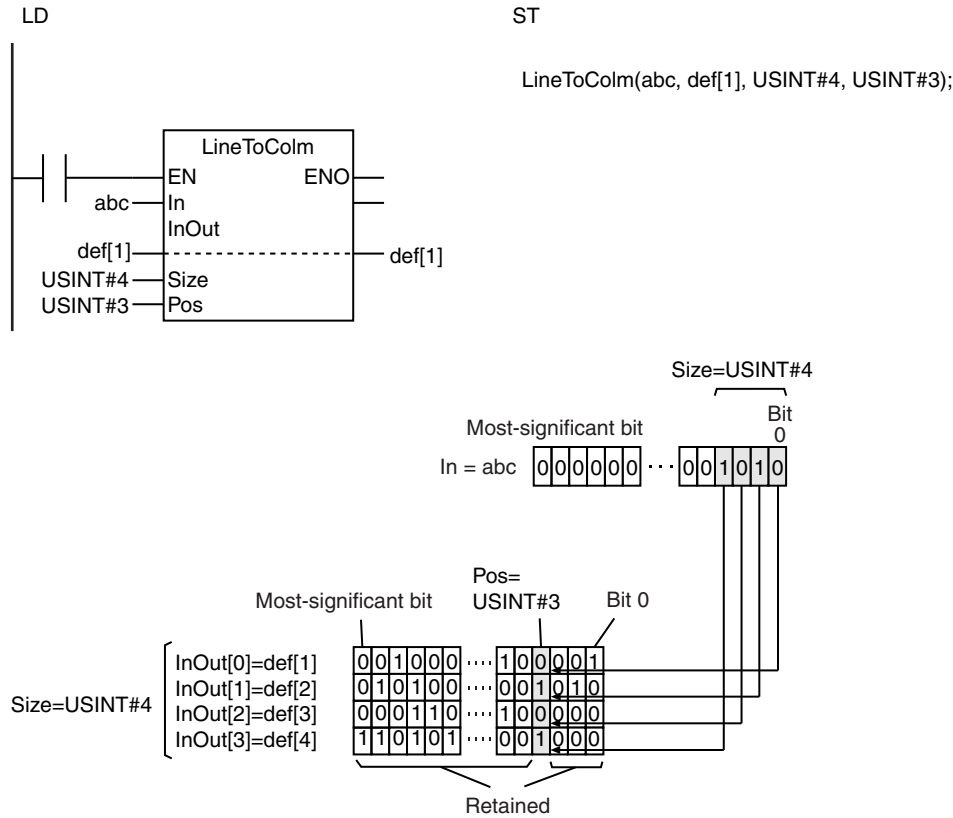

Additional Information

Use the `ColmToLine_**` instruction (page 2-413) to extract bit values from the specified position of array elements and output them as a bit string.

Precautions for Correct Use

- If the value of *Size* is 0, the values in *InOut[]* do not change.
- Return value *Out* is not used when the instruction is used in ST.
- An error occurs in the following cases. *ENO* will be FALSE, and *InOut[]* will not change.
 - The value of *Size* is outside of the valid range.
 - The value of *Pos* is outside of the valid range.
 - The value of *Size* exceeds the array area of *InOut[]*.

Gray

The Gray instruction converts a gray code into an angle.

Instruction	Name	FB/FUN	Graphic expression	ST expression
Gray	Gray Code Conversion	FUN		Out:=Gray(In, Resolution, ERC, ZPC);

Variables

Name	Meaning	I/O	Description	Valid range	Unit	Default
In	Data to convert	Input	Gray code to convert	Depends on data type.	---	0
Resolution	Resolution		Resolution	_R256, _R1B to _R15B, _R360, _R720, or _R1024		_R256
ERC	Encoder remainder correction		Encoder remainder correction	0 to <i>Resolution</i>		0
ZPC	Zero point correction		Zero point correction			
Out	Conversion result	Output	Conversion result	*	°	---

* 0 to 3.5999999999999999e+2

	Boolean	Bit strings				Integers							Real numbers	Times, durations, dates, and text strings							
	BOOL	BYTE	WORD	DWORD	LWORD	USINT	UINT	UDINT	ULINT	SINT	INT	DINT	LINT	REAL	LREAL	TIME	DATE	TOD	DT	STRING	
In			OK																		
Resolution	Refer to <i>Function</i> for the enumerators of the enumerated type <code>_eGRY_RESOLUTION</code> .																				
ERC							OK														
ZPC							OK														
Out														OK							

Function

The Gray instruction converts the gray code in *In* (the output value from a rotary encoder) to an angle. The conversion result *Out* is in degrees.

The data type of *Resolution* is enumerated type `_eGRY_RESOLUTION`. The meaning of the enumerators are as follows:

Enumerator	Meaning
<code>_R256</code>	256
<code>_R1B</code>	1-bit (2)
<code>_R2B</code>	2-bit (4)
<code>_R3B</code>	3-bit (8)
<code>_R4B</code>	4-bit (16)
<code>_R5B</code>	5-bit (32)
<code>_R6B</code>	6-bit (64)
<code>_R7B</code>	7-bit (128)
<code>_R8B</code>	8-bit (256)
<code>_R9B</code>	9-bit (512)
<code>_R10B</code>	10-bit (1024)
<code>_R11B</code>	11-bit (2048)
<code>_R12B</code>	12-bit (4096)
<code>_R13B</code>	13-bit (8192)
<code>_R14B</code>	14-bit (16384)
<code>_R15B</code>	15-bit (32768)
<code>_R360</code>	360
<code>_R720</code>	720
<code>_R1024</code>	1024

Gray Code

The Gray code is a reflected binary code. Two successive values, such as 0 and 1 and 1 and 2, differ in only one bit. Gray codes are used for the output from absolute encoders.

The following tables shows the 4-bit Binary code and Gray code.

Decimal number	Binary code				Gray code			
	2^3	2^2	2^1	2^0	d	c	b	a
0	0	0	0	0	0	0	0	0
1	0	0	0	1	0	0	0	1
2	0	0	1	0	0	0	1	1
3	0	0	1	1	0	0	1	0
4	0	1	0	0	0	1	1	0
5	0	1	0	1	0	1	1	1
6	0	1	1	0	0	1	0	1
7	0	1	1	1	0	1	0	0
8	1	0	0	0	1	1	0	0
9	1	0	0	1	1	1	0	1
10	1	0	1	0	1	1	1	1
11	1	0	1	1	1	1	1	0
12	1	1	0	0	1	0	1	0
13	1	1	0	1	1	0	1	1
14	1	1	1	0	1	0	0	1
15	1	1	1	1	1	0	0	0

Using the Gray code enables prevention of instantaneously incorrect output values because only one bit in the Gray code will change when the output value of the encoder is incremented or decremented by 1. The following figure shows the difference in the output value from an encoder for the Gray code and Binary code.

Difference When Output Value Changes from 1 to 2

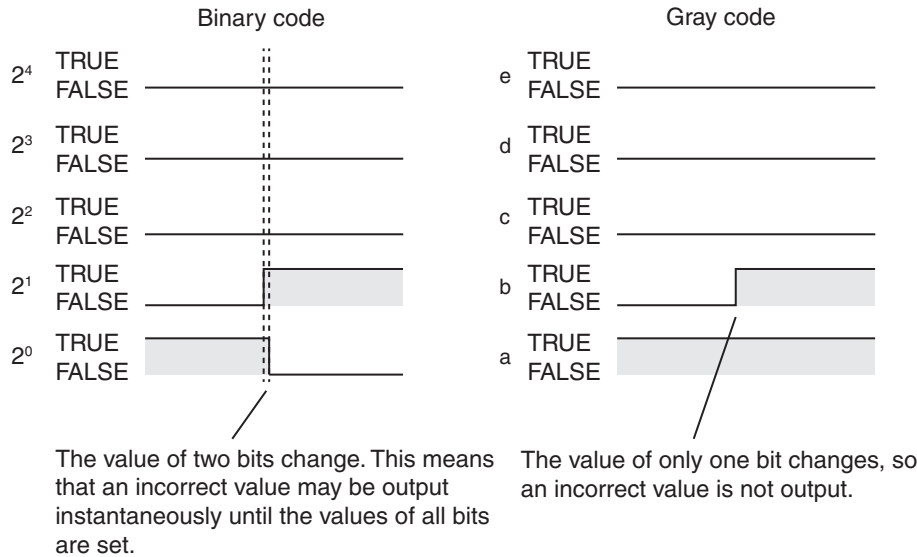

ERC: Encoder Remainder Correction

The *ERC* variable is used to specify the Gray code range when the encoder resolution is not a power of 2. The range is specified so that there is only one bit difference between the maximum and minimum encoder output values. For example, consider the use of an absolute encoder with a resolution of 360. Nine bits are used for the Gray code. The range that can be expressed with nine bits is 0 to 511. In this case, a range of 180 from the center of 0 to 511 is used for the Gray code, i.e., 76 to 435. Therefore, a Gray code of 001101010 (76 decimal) is output for an output value of 0, and a Gray code of 101101010 (435 decimal) is output for an output value of 359. There is a difference in only one bit between these values. In this case, the value of encoder remainder correction *ERC* is 76.

Decimal	Gray code									ERC (encoder remainder correction)
	i	h	g	f	e	d	c	b	a	
0	0	0	0	0	0	0	0	0	0	76
...	...									
76	0	0	1	1	0	1	0	1	0	
...	...									180
255	0	1	0	0	0	0	0	0	0	
256	1	1	0	0	0	0	0	0	0	
...	...									180
435	1	0	1	1	0	1	0	1	0	
...	...									
511	1	0	0	0	0	0	0	0	0	76

Resolution: 360

For an output value of 0

For an output value of 359

There is a difference in only one bit.

ZPC: Zero Point Correction

The *ZPC* variable is set to offset the zero position of the rotary encoder. For example, to offset the zero position for a rotary encoder with a resolution of 256, the value of *ZPC* would be $256 \times (90/360)$, or 64.

Notation Example

The following example is for when *In* is WORD#16#1A9, *Resolution* is _R10B, *ERC* is UINT#0, and *ZPC* is UINT#337.

First, the resolution is 10 bits, so one increment in the Gray code is $360^\circ/1,024$, or 0.35° . A decimal value of 305 corresponds to a Gray code of 16#01A9. Therefore, the angle before compensation is $0.35^\circ \times 305$, or 106.75° . The value of *ERC* is 0 and the value of *ZPC* is 377. Therefore, the angle after compensation is $106.75^\circ - (0 + 337) \times 0.35^\circ$, or -11.20° . The range of the values of *Out* is 0 or greater, so the value is $-11.20^\circ + 360^\circ$, or 348.80° . The value of *Out* will be LREAL#348.8.

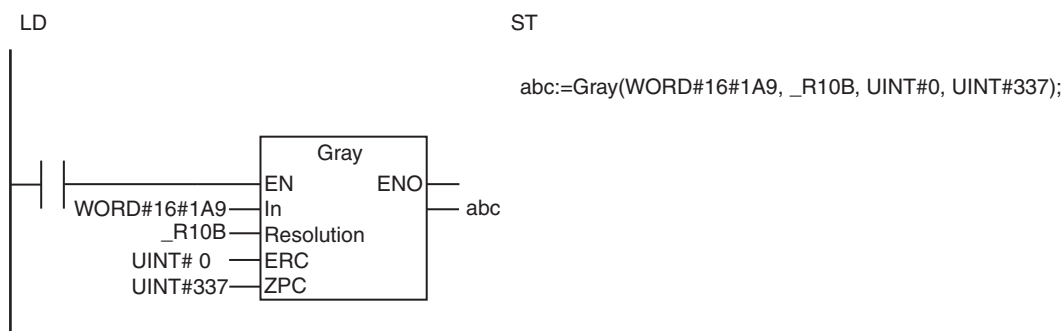

```
ST
abc:=Gray(WORD#16#1A9, _R10B, UINT#0, UINT#337);
```

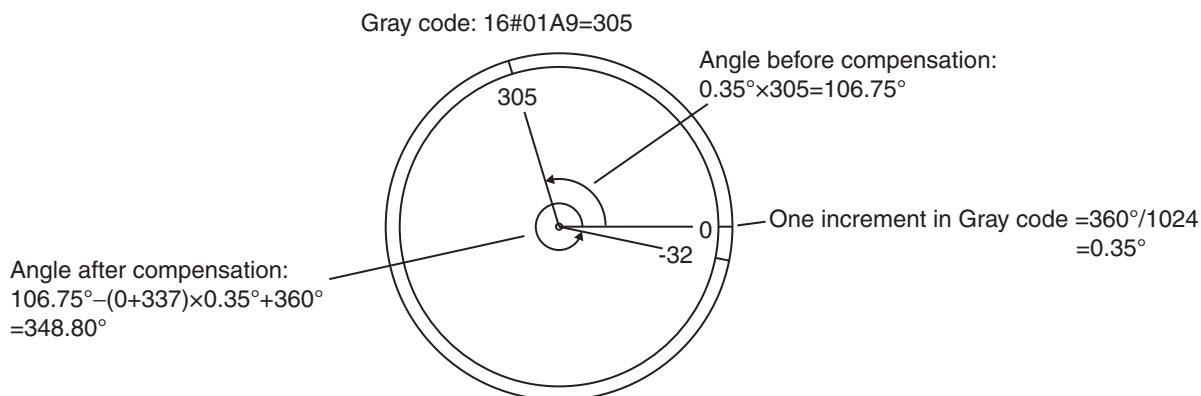

Additional Information

Refer to the user documentation for your rotary encoder for the values to specify for *Resolution* and *ERC*.

Converting from Gray Code to Binary Code

The following processing can be used to convert from Gray code to Binary code. The logic symbols in the figure represent logical exclusive ORs.

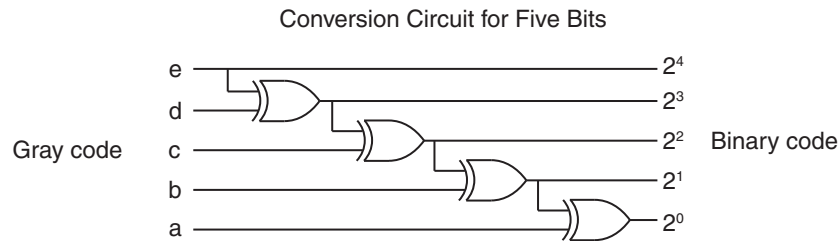

Precautions for Correct Use

An error occurs in the following cases. *ENO* will be FALSE, and *Out* will not change.

- The value of *Resolution* is outside of the valid range.
- The value of *ERC* exceeds the resolution that is specified in *Resolution*.
- The value of *ZPC* exceeds the resolution that is specified in *Resolution*.
- *In*, when converted to a bit string, is smaller than the value of *ERC*.
- The value of the bit string after correction for *ERC* exceeds the resolution that is specified in *Resolution*.

UTF8ToSJIS

The UTF8ToSJIS instruction converts a UTF-8 text string to a SJIS BYTE array.

Instruction	Name	FB/FUN	Graphic expression	ST expression
UTF8ToSJIS	UTF-8 to SJIS Character Code Conversion	FUN		Out:=UTF8ToSJIS(In, SJISCode);

Variables

Name	Meaning	I/O	Description	Valid range	Unit	Default
In	Text string to convert	Input	Text string to convert	Depends on data type.	---	"
SJIS-Code[] (array)	SJIS array	In-out	Array of SJIS character codes	Depends on data type.	---	---
Out	Number of converted elements	Output	Number of elements stored in <i>SJISCode[]</i>	0 to 1985	---	---

	Boolean	Bit strings					Integers							Real numbers		Times, durations, dates, and text strings				
	BOOL	BYTE	WORD	DWORD	LWORD	USINT	UINT	UDINT	ULINT	SINT	INT	DINT	LINT	REAL	LREAL	TIME	DATE	TOD	DT	STRING
In																				OK
SJIS-Code[] (array)		OK																		
Out							OK													

Function

The UTF8ToSJIS instruction converts the text string to convert in *In* (a UTF-8 text string) to a SJIS array in *SJISCode[]* (a BYTE array of SJIS character codes). Each byte of the converted data is stored in order starting from *SJISCode[0]*.

The number of elements of converted data that was stored in *SJISCode[]* is stored as the number of converted elements in *Out*.

The following example is for when *In* is 'あ'.

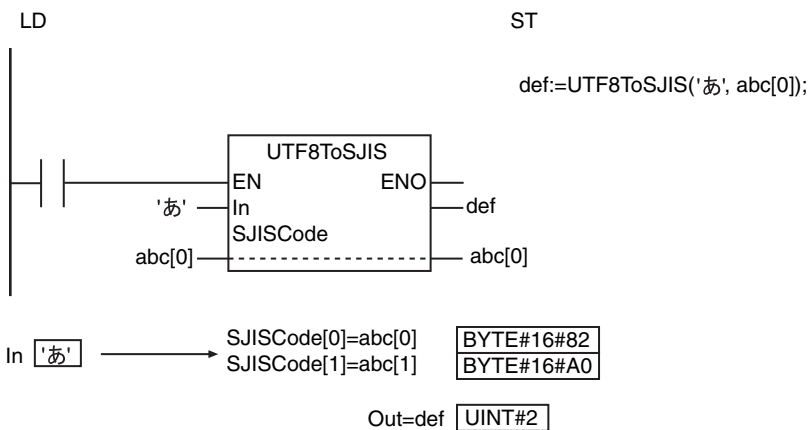

Precautions for Correct Use

- NULL characters at the end of *In* are not converted. They are also not counted for the number of converted elements.
- If the *In* text string contains only the NULL character, the value of *Out* will be 0 and *SJISCode[]* will not change.
- The elements of *SJISCode[]* past the number of elements specified in *Out* do not change. For example, if the number of converted elements is 5, *SJISCode[5]* and later elements do not change.
- An error occurs in the following cases. *ENO* will be FALSE, and *Out* and *SJISCode[]* will not change.
 - The number of elements in the conversion result exceeds the size of the output parameter that is connected to *SJISCode[]*.
 - The contents of *In* includes characters that cannot be converted.



Version Information

A CPU Unit with unit version 1.01 or later and Sysmac Studio version 1.02 or higher are required to use this instruction.

SJISToUTF8

The SJISToUTF8 instruction converts a SJIS BYTE array to a UTF-8 text string.

Instruction	Name	FB/FUN	Graphic expression	ST expression
SJISToUTF8	SJIS to UTF-8 Character Code Conversion	FUN		Out:=SJISToUTF8(In, Size);

Variables

Name	Meaning	I/O	Description	Valid range	Unit	Default
In[] (array)	SJIS array to convert	Input	Array of SJIS character codes to convert* ¹	Depends on data type.	---	*2
Size	Number of SJIS array elements		Number of elements of In[] to convert			---
Out	Resulting text string	Output	UTF-8 text string after conversion	Depends on data type.	---	---

*1 The maximum number of elements is 1,986, including the NULL character (BYTE#16#00). The maximum number of elements is 1,985 without the NULL character.

*2 If you omit the input parameter, the default value is not applied. A building error will occur.

	Boolean	Bit strings					Integers							Real numbers		Times, durations, dates, and text strings				
	BOOL	BYTE	WORD	DWORD	LWORD	USINT	UINT	UDINT	ULINT	SINT	INT	DINT	LINT	REAL	LREAL	TIME	DATE	TOD	DT	STRING
In[] (array)		OK																		
Size							OK													
Out																				OK

Function

The SJISToUTF8 instruction converts the elements in a SJIS array to convert in In[] (a BYTE array) to a UTF-8 text string. Size number of elements are converted starting with In[0]. However, if there is a NULL character (BYTE#16#00) before Size elements are converted, conversion is canceled at that point.

The resulting text string after conversion is stored as resulting text string in Out. A NULL character is placed at the end of Out.

The following example is for when $In[0]$ is BYTE#16#82, $In[1]$ is BYTE#16#A0, and $Size$ is UINT#2.

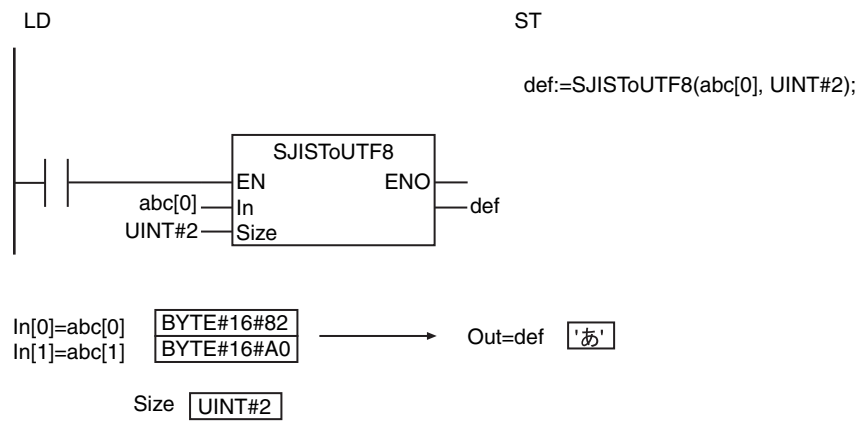

Precautions for Correct Use

- If the value of $Size$ is 0, Out is a text string containing only the NULL character.
- An error occurs in the following cases. ENO will be FALSE, and Out will not change.
 - The value of $Size$ exceeds the number of elements in $In[]$.
 - The contents of $In[]$ includes characters that cannot be converted.



Version Information

A CPU Unit with unit version 1.01 or later and Sysmac Studio version 1.02 or higher are required to use this instruction.

PWLApprox and PWLApproxNoLineChk

The PWLApprox and PWLApproxNoLineChk instructions perform broken line approximations for integer or real number data.

PWLApprox: Checks to see if the broken line data is valid.

PWLApproxNoLineChk: Does not check to see if the broken line data is valid.

Instruction	Name	FB/FUN	Graphic expression	ST expression
PWLApprox	Broken Line Approximation with Broken Line Data Check	FUN		Out:=PWLApprox(In, Line, Num);
PWL Approx NoLineChk	Broken Line Approximation without Broken Line Data Check	FUN		Out:=PWLApproxNoLineChk(In, Line, Num);

Variables

Name	Meaning	I/O	Description	Valid range	Unit	Default
In	Data to convert	Input	Data to convert	Depends on data type.	---	*
Line[] (array)	Broken line data array		Broken line data array			
Num	Number of broken line data		Number of broken line data			
Out	Conversion result	Output	Conversion result	Depends on data type.	---	---

* If you omit the input parameter, the default value is not applied. A building error will occur.

	Boolean	Bit strings				Integers								Real numbers	Times, durations, dates, and text strings					
	BOOL	BYTE	WORD	DWORD	LWORD	USINT	UINT	UDINT	ULINT	SINT	INT	DINT	LINT	REAL	LREAL	TIME	DATE	TOD	DT	STRING
In						OK	OK	OK	OK	OK	OK	OK	OK	OK	OK					
Line[] (array)	Must be an array with elements that have the same data type as <i>In</i> .																			
Num							OK													
Out						OK	OK	OK	OK	OK	OK	OK	OK	OK	OK					

Function

The PWLApprox and PWLApproxNoLineChk instructions perform approximation for data to convert *In*. The approximation is based on broken line data that consists of *Num* times 2 elements that start with *Line[0,0]* in broken line data array *Line[]*.

As shown below, the Y coordinate that corresponds to the X coordinate *In* of the broken line data is assigned to conversion result *Out*.

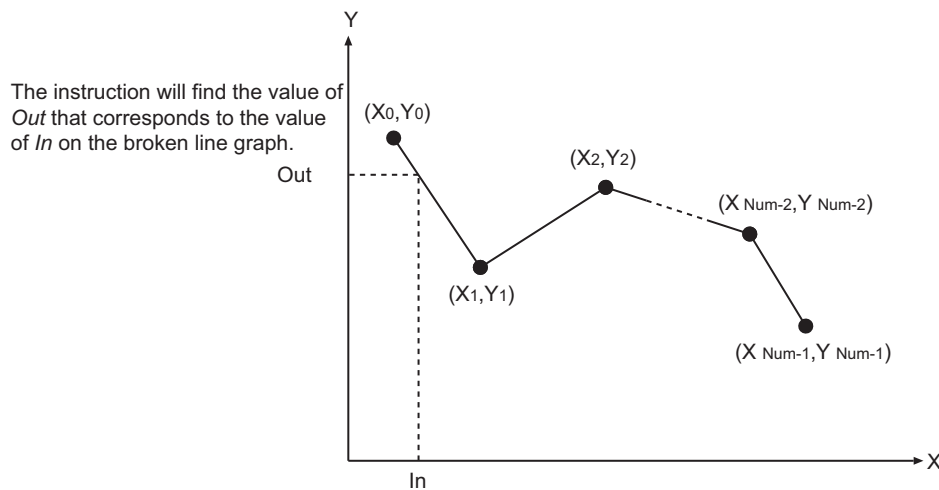

Elements of Broken Line Data Array *Line[]* and Number of Broken Line Data *Num*

Line[] must be a two-dimensional or three-dimensional array. Set the number of elements for the first dimension to 2. Then use the coordinate values (X_0, Y_0) , (X_1, Y_1) , etc., of the points in the broken line data as the elements of *Line[]* as shown in the following figure. The number of broken line data *Num* is one half of the number of elements of *Line[]*, which is used in the broken line approximation calculations.

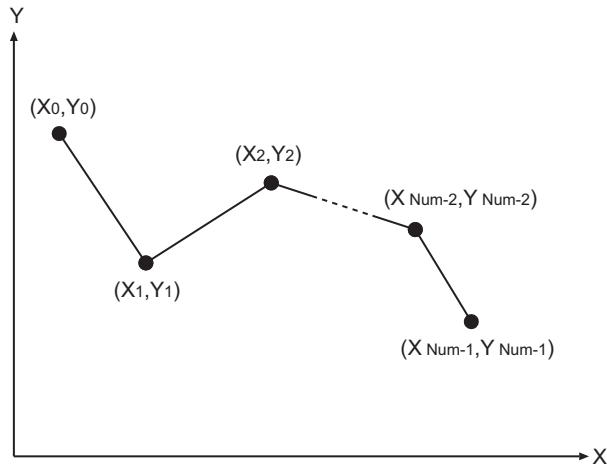

Using a Two-dimensional Array for *Line[]* Using a Three-dimensional Array for *Line[]*

Line[0,0]	X ₀	Line[0,0,0]	X ₀
Line[0,1]	Y ₀	Line[0,0,1]	Y ₀
Line[1,0]	X ₁	Line[0,1,0]	X ₁
Line[1,1]	Y ₁	Line[0,1,1]	Y ₁
Line[2,0]	X ₂	Line[0,2,0]	X ₂
Line[2,1]	Y ₂	Line[0,2,1]	Y ₂
⋮	⋮	⋮	⋮
Line[Num-1,0]	X Num-1	Line[0, Num-1,0]	X Num-1
Line[Num-1,1]	Y Num-1	Line[0, Num-1,1]	Y Num-1

Notation Example

An example of approximation when the value of *In* is LREAL#3.0 for broken line data array *abc[]* with four elements is given below. The values of the elements of *abc[]* are given below for when *Num* is UINT#4.

$abc[0.0] = X_0 = \text{LREAL}\#1.0$, $abc[0,1] = Y_0 = \text{LREAL}\#5.0$,

$abc[1.0] = X_1 = \text{LREAL}\#2.0$, $abc[1,1] = Y_1 = \text{LREAL}\#6.0$,

$abc[2.0] = X_2 = \text{LREAL}\#4.0$, $abc[2,1] = Y_2 = \text{LREAL}\#2.0$,

$abc[3.0] = X_3 = \text{LREAL}\#5.0$, $abc[3,1] = Y_3 = \text{LREAL}\#3.0$

The value of conversion result *Out* will be LREAL#4.0.

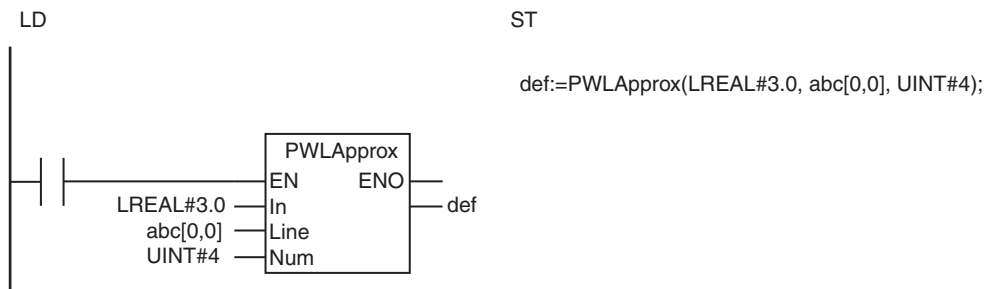

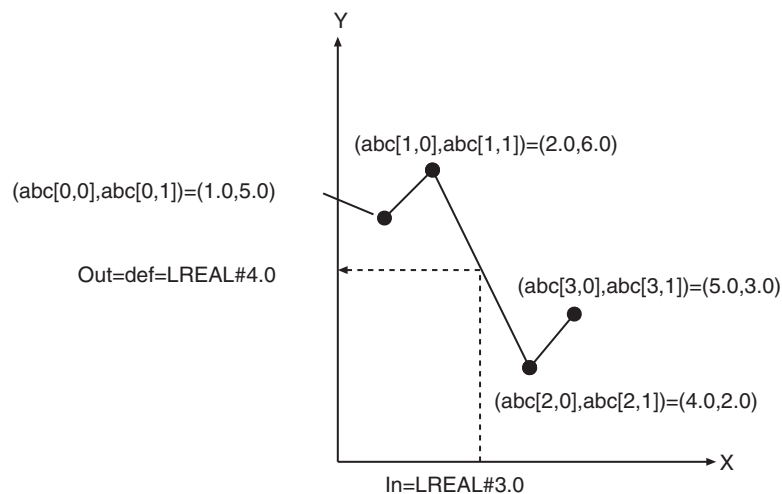

Difference between the PWLApprox and PWLApproxNoLineChk Instructions

The PWLApprox and PWLApproxNoLineChk instructions are different in whether the validity of *In* and *Line[]* are checked. This also makes the processing times different. The specifications of both instructions are given in the following table.

Instruction	Checks	Processing when the data is not valid	Processing time
PWLApprox	<ul style="list-style-type: none"> The contents of <i>Line[]</i> are checked to make sure the elements are in ascending order of the X coordinates. If <i>In</i> and <i>Line[]</i> are integers, <i>In</i> and the elements of <i>Line[]</i> are checked to make sure they are not nonnumeric data, positive infinity, or negative infinity. 	<ul style="list-style-type: none"> An error occurs. The value of <i>ENO</i> will be FALSE. The value of <i>Out</i> will not change. 	Long
PWLApproxNoLineChk	No checks are performed.	<ul style="list-style-type: none"> An error will not occur. The value of <i>ENO</i> will be TRUE. A valid value may not be output to <i>Out</i>. 	Short

PWLApproxNoLineChk and PWLLineChk Instructions

Although the PWLApproxNoLineChk instruction does not check the validity of *In* and *Line[]*, the processing time is short. Therefore, if you can be sure that the input variables are valid, it is better to use the PWLApproxNoLineChk instruction rather than the PWLApprox instruction.

The PWLLineChk instruction (page 2-432) checks the contents of *Line[]* to see if the X coordinates are in ascending order. Therefore, you can shorten the processing time if you normally use the PWLApproxNoLineChk instruction and combine the PWLLineChk instruction with it only when you cannot ensure that the X coordinates in *Line[]* are in ascending order.

Additional Information

You can also shorten the processing time by restricting the range of elements in the broken line data array that is used for approximation conversion.

In the previous example, the processing time will be shorter for the value of *In* (LREAL#3.0) if the values of the X coordinates in the elements of the broken line data array consist of only the four elements that are close to 3.0 ($abc[1,0], abc[1,1])=(2.0,6.0)$ and $(abc[2,0], abc[2,1])=(4.0,2.0)$.

In this case, *Num* is UINT#2 and the element of *abc[]* that is passed to *Line[]* is *abc[1,0]*.

The conversion result *Out* is still LREAL#4.0.

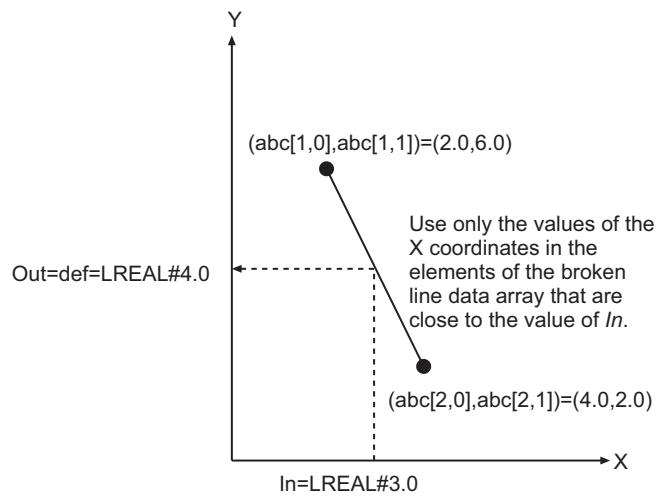
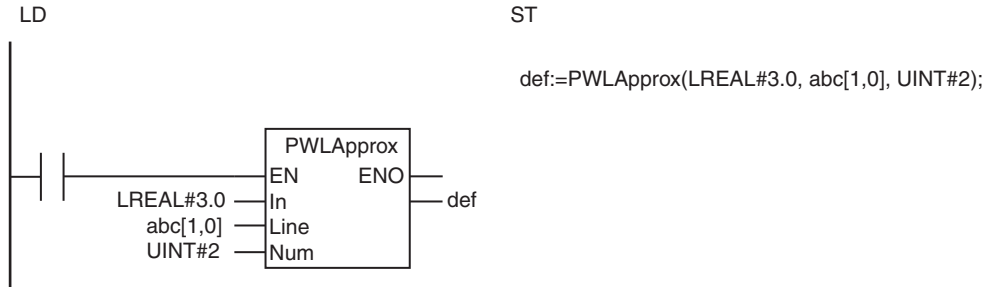

Precautions for Correct Use

- If the value of *In* is smaller than the value of *Line*[0,0] (i.e., the value of X_1), then the value of *Out* will be the value of *Line*[0,1] (i.e., the value of Y_1).
- If the value of *In* is larger than the value of *Line*[*Num*-1,0] (i.e., the value of X_{Num}), then the value of *Out* will be the value of *Line*[*Num*-1,1] (i.e., the value of Y_{Num}).
- *Line*[] must be a two-dimensional or three-dimensional array. Set the number of elements for the first dimension to 2.
- If the value of *Num* is 0, the value of *Out* is 0.
- An error will occur for the PWLApprox instruction in the following cases. *ENO* will be FALSE, and *Out* will not change. An error will not occur in these cases for the PWLApproxNoLineChk instruction.
 - The X coordinates of the broken line data are not in ascending order, the condition $X_1 < X_2 < \dots < X_{Num}$ is not met.
 - *In* and *Line*[] are REAL data and their values are nonnumeric data, positive infinity, or negative infinity.
- An error will occur for the PWLApprox instruction and the PWLApproxNoLineChk instruction in the following cases. *ENO* will be FALSE, and *Out* will not change.
 - The value of *Num* exceeds the array area of *Line*[].
 - The value of *In* exceeds the X coordinates in the broken line data that is specified for *Line*[].



Version Information

A CPU Unit with unit version 1.03 or later and Sysmac Studio version 1.04 or higher are required to use the PWLApproxNoLineChk instruction.

PWLLineChk

The PWLLineChk instruction is used to check whether the X coordinates in the broken line data that is used for a Broken Line Approximation without Broken Line Data Check instruction are in ascending order.

Instruction	Name	FB/FUN	Graphic expression	ST expression
PWLLineChk	Broken Line Data Check	FUN		Out:=PWLLineChk(Line, Num);

Variables

Name	Meaning	I/O	Description	Valid range	Unit	Default
Line[] (array)	Broken line data array	Input	Broken line data array	Depends on data type.	---	(*)
Num	Number of broken line data		Number of broken line data			1
Out	Result	Output	Result	Depends on data type.	---	---

* If you omit the input parameter, the default value is not applied. A building error will occur.

	Boolean	Bit strings				Integers							Real numbers		Times, durations, dates, and text strings					
	BOOL	BYTE	WORD	DWORD	LWORD	USINT	UINT	UDINT	ULINT	SINT	INT	DINT	LINT	REAL	LREAL	TIME	DATE	TOD	DT	STRING
Line[] (array)						OK	OK	OK	OK	OK	OK	OK	OK	OK						
Num							OK													
Out	OK																			

Function

The PWLLineChk instruction is used to check whether the X coordinates in the broken line data array *Line[]* that is used for a Broken Line Approximation without Broken Line Data Check (PWLAapproxNo-LineChk) instruction are in ascending order. If the X coordinates are in ascending order, result *Out* will be TRUE. If they are not, result *Out* will be FALSE.

Elements of Broken Line Data Array *Line[]* and Number of Broken Line Data *Num*

Line[] must be a two-dimensional or three-dimensional array. Set the number of elements for the first dimension to 2. Then use the coordinate values (X_0, Y_0) , (X_1, Y_1) , etc., of the points in the broken line data as the elements of *Line[]* as shown in the following figure. The number of broken line data *Num* is one half of the number of elements of *Line[]*, which is used in the broken line approximation calculations.

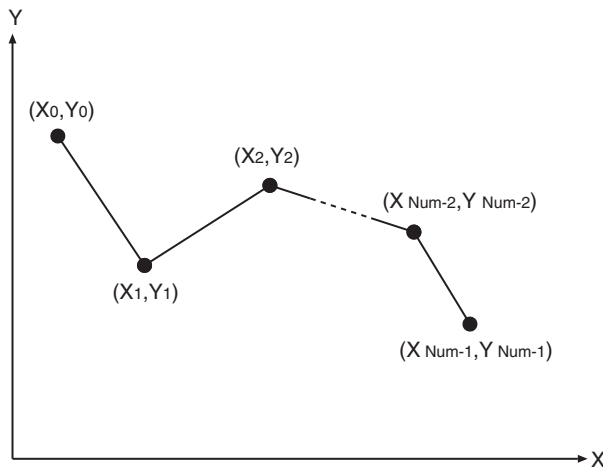

Using a Two-dimensional Array for *Line*[]

Line[0,0]	X ₀
Line[0,1]	Y ₀
Line[1,0]	X ₁
Line[1,1]	Y ₁
Line[2,0]	X ₂
Line[2,1]	Y ₂
⋮	⋮
Line[Num-1,0]	X Num-1
Line[Num-1,1]	Y Num-1

Using a Three-dimensional Array for *Line*[][]

Line[0,0,0]	X ₀
Line[0,0,1]	Y ₀
Line[0,1,0]	X ₁
Line[0,1,1]	Y ₁
Line[0,2,0]	X ₂
Line[0,2,1]	Y ₂
⋮	⋮
Line[0, Num-1,0]	X Num-1
Line[0, Num-1,1]	Y Num-1

Notation Example

An example of determining whether the X coordinates are in ascending order in the broken line data array *abc*[] with four elements is given below. The values of the elements of *abc*[] are given below for when *Num* is *UINT#4*.

abc[0.0] = X₀ = LREAL#1.0, *abc*[0,1] = Y₀ = LREAL#5.0,

abc[1.0] = X₁ = LREAL#6.0, *abc*[1,1] = Y₁ = LREAL#6.0,

abc[2.0] = X₂ = LREAL#4.0, *abc*[2,1] = Y₂ = LREAL#2.0,

abc[3.0] = X₃ = LREAL#5.0, *abc*[3,1] = Y₃ = LREAL#3.0

The X coordinates are not in ascending order, so the value of *Out* is FALSE.

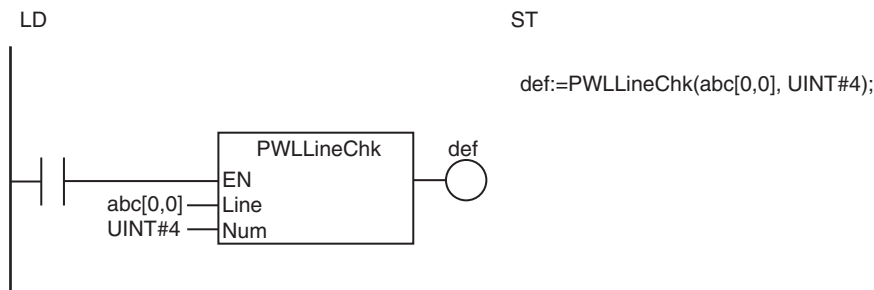

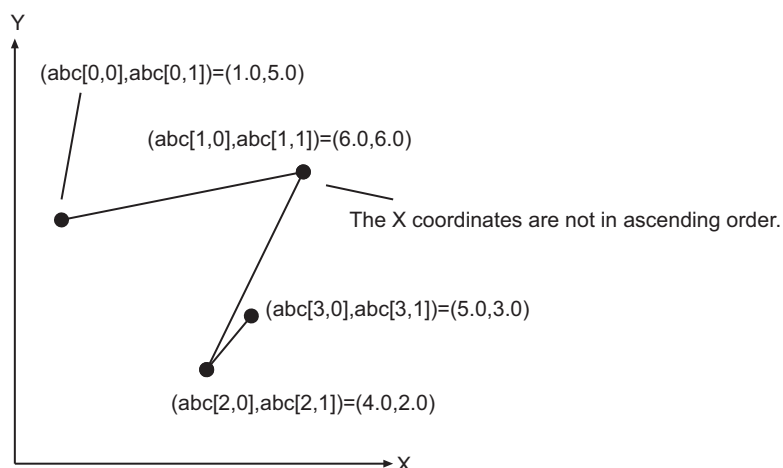

Additional Information

- Use the `PWLLineChk` in combination with the `PWLApproxNoLineChk` instruction. Refer to *PWLApprox and PWLApproxNoLineChk Instructions* (page 2-426) for details on the `PWLApproxNoLineChk` instruction.
- Use the `PWLApprox` instruction to check the broken line data every time you perform broken line approximation. Refer to *PWLApprox and PWLApproxNoLineChk Instructions* (page 2-426) for details on the `PWLApprox` instruction. The processing time of the `PWLApproxNoLineChk` instruction is shorter than the processing time of the `PWLApprox` instruction.

Precautions for Correct Use

- `Line[]` must be a two-dimensional or three-dimensional array. Set the number of elements for the first dimension to 2.
- An error will occur in the following cases. `Out` will be `FALSE`.
 - The value of `Num` exceeds the array area of `Line[]`.
 - `Line[]` is `REAL` data and an element is nonnumeric data, positive infinity, or negative infinity.



Version Information

A CPU Unit with unit version 1.03 or later and Sysmac Studio version 1.04 or higher are required to use this instruction.

MovingAverage

The MovingAverage instruction calculates a moving average.

Instruction	Name	FB/FUN	Graphic expression	ST expression
MovingAverage	Moving Average	FUN	<pre> graph LR EN --- ENO In --- ENO CurIndex --- ENO Buf --- ENO BufSize --- ENO Q --- ENO ENO --- Out </pre>	Out:=MovingAverage(In, CurIndex, Buf, BufSize, Q);

Variables

Name	Meaning	I/O	Description	Valid range	Unit	Default
In	Input value	Input	Number to include in average	Depends on data type.	---	*
BufSize	Maximum number stored		Maximum number of elements to include in average			1
CurIndex	Input value storage position	In-out	Position in <i>Buf[]</i> in which to store <i>In</i>	Depends on data type.	---	---
Buf[] (array)	Input value storage array		Array to store <i>In</i> values			
Q	Calculation completed flag		TRUE: <i>BufSize</i> elements or more have been stored in <i>Buf[]</i> FALSE: <i>BufSize</i> elements are not yet stored in <i>Buf[]</i>			
Out	Calculation result	Output	Calculation result	Depends on data type.	---	---

* If you omit the input parameter, the default value is not applied. A building error will occur.

	Boolean	Bit strings				Integers								Real numbers		Times, durations, dates, and text strings				
	BOOL	BYTE	WORD	DWORD	LWORD	USINT	UINT	UDINT	ULINT	SINT	INT	DINT	LINT	REAL	LREAL	TIME	DATE	TOD	DT	STRING
In						OK	OK	OK	OK	OK	OK	OK	OK	OK						
BufSize							OK													
CurIndex							OK													
Buf[] (array)	Must be an array with elements that have the same data type as <i>In</i> .																			
Q	OK																			
Out						OK	OK	OK	OK	OK	OK	OK	OK	OK						

Function

The MovingAverage instruction stores the value of input value *In* in input value storage array *Buf[]* each time it is executed. It stores the average of the stored values in calculation result *Out*. Specify the maximum number of elements to include in the average with *BufSize*.

The processing procedure when *BufSize* is UINT#3 is described below as an example. The instruction and statement are written as follows:

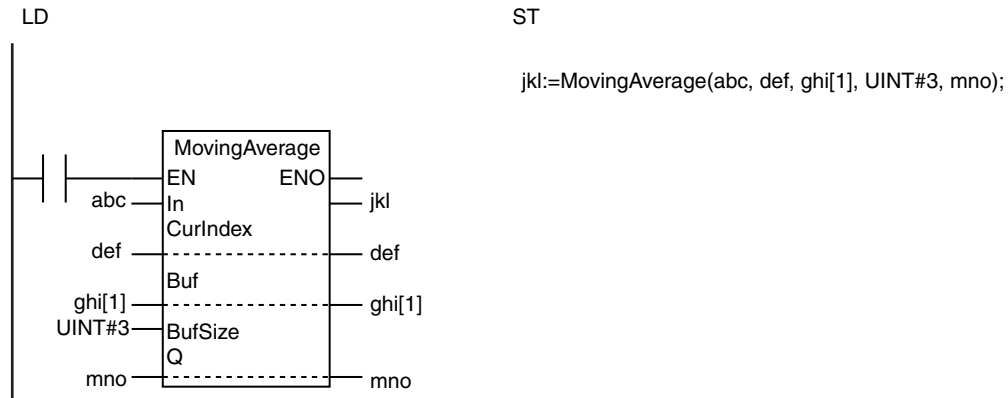

First Time a Number Is Input

The input value storage position *CurIndex* is set to 0 and the instruction is executed.

Buf[0] to *Buf[BufSize-1]* of input value storage array *Buf[]* are cleared to zeros and the first input value *In* is stored in *Buf[0]*.

The value of calculation completed flag *Q* changes to FALSE. This indicates that the number of values that are stored in *Buf[]* has not reached *BufSize* yet.

While the value of *Q* is FALSE, the average value is calculated for the *CurIndex* + 1 numbers that start from *Buf[0]*. The calculation result is stored in *Out*.

Finally, the value of *CurIndex* is incremented.

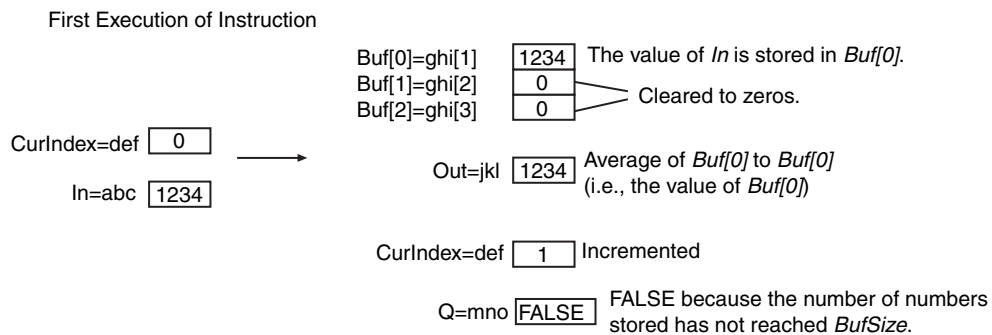

Inputting Numbers Up to *BufSize*

Each time the instruction is executed, the value of *In* is stored in *Buf[CurIndex]*. The average of *CurIndex* + 1 numbers that start from *Buf[0]* is calculated and stored in *Out*.

When the number of instruction executions reaches *BufSize*, the value of *Q* changes to TRUE.

Second Execution of Instruction

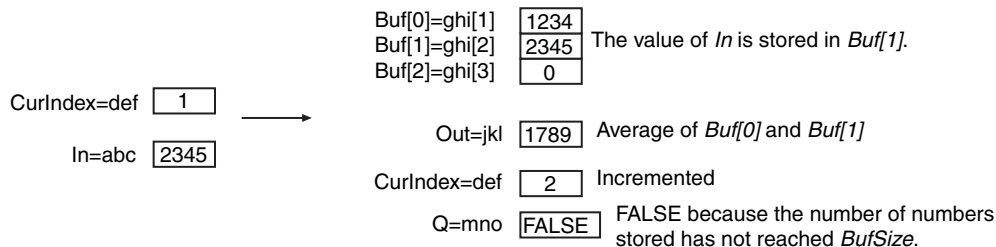

Third Execution of Instruction

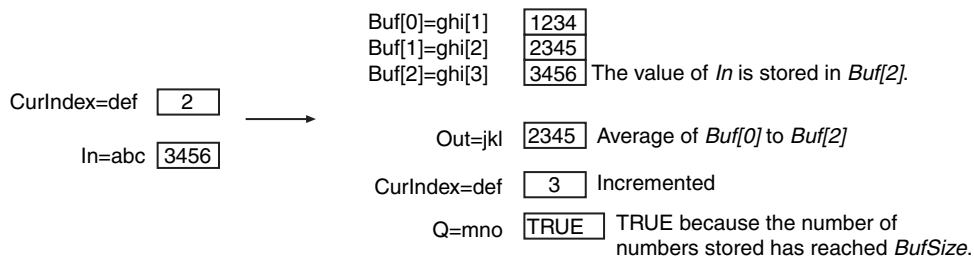

Inputting Numbers after Reaching *BufSize*

Each time the instruction is executed, *Buf[0]* to *Buf[BufSize-1]* are overwritten with the value of *In* in cyclic fashion. The average of *Buf[0]* to *Buf[BufSize-1]* is calculated and stored in *Out*.

The value of *CurIndex* returns to 1 after it reaches *BufSize* and it is then incremented again. The value of *Q* remains TRUE.

Fourth Execution of Instruction

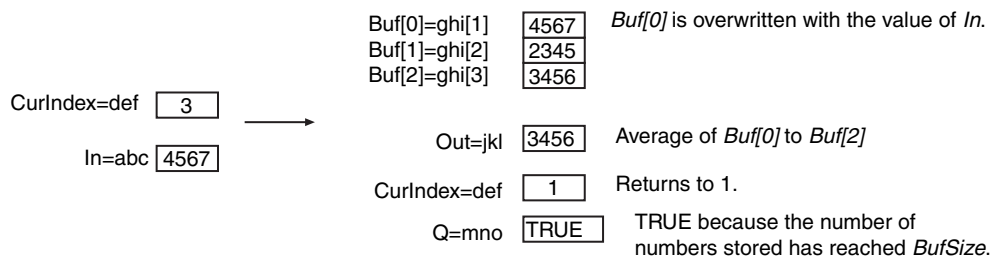

Fifth Execution of Instruction

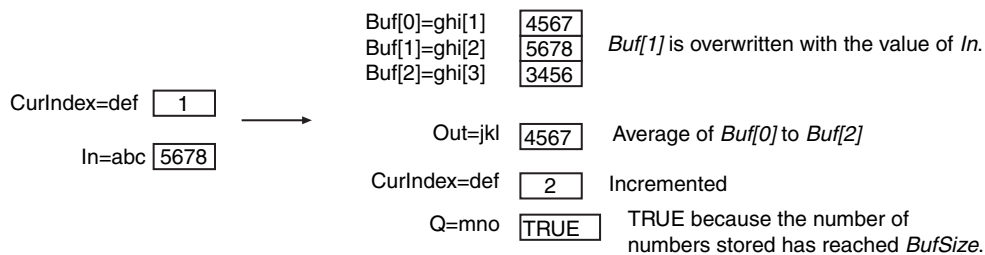

Initializing the Stored Values

If the value of *CurIndex* is set to 0 before the instruction is executed, the values in *Buf[0]* to *Buf[BufSize-1]* are set to 0 and the current value of *In* is stored again in *Buf[0]*.

The value of *CurIndex* changes to 1 and the value of *Q* changes to FALSE.

Changing the Value of *BufSize*

If you change the value of *BufSize* and execute the instruction, operation is performed with the new value of *BufSize* and the current value of *CurIndex*.

Status before Instruction Execution *BufSize*=3

<i>Buf</i> [0]=ghi[1]	4567
<i>Buf</i> [1]=ghi[2]	2345
<i>Buf</i> [2]=ghi[3]	3456

<i>Out</i> =jkl	3456
-----------------	------

<i>CurIndex</i> =def	2
----------------------	---

<i>Q</i> =mno	TRUE
---------------	------

Instruction Execution after Setting *BufSize* to 2

<i>CurIndex</i> =def	2	→	<i>Buf</i> [0]=ghi[1]	5678	<i>CurIndex</i> is equal to or higher than <i>BufSize</i> , so the value of <i>In</i> is stored in <i>Buf</i> [1].
<i>In</i> =abc	5678		<i>Buf</i> [1]=ghi[2]	2345	
			<i>Buf</i> [2]=ghi[3]	3456	Not included in the average.
			<i>Out</i> =jkl	4011	Average of <i>Buf</i> [0] and <i>Buf</i> [1]
			<i>CurIndex</i> =def	1	<i>CurIndex</i> is equal to or higher than <i>BufSize</i> , so the value of <i>CurIndex</i> returns to 1.
			<i>Q</i> =mno	TRUE	TRUE because the number of numbers stored has reached <i>BufSize</i> .

Precautions for Correct Use

- Use the same data type for *In* and the elements of *Buf[]*. If they are different, a building error will occur.
- Use a *Buf[]* array that is at least as large as the value of *BufSize*.
- Even if the calculation result exceeds the valid range of *Out*, an error will not occur. The value of *Out* will be an illegal value.
- If the value of *BufSize* is 0, the values of *Out* and *CurIndex* change to 0. The value of *Q* changes to TRUE.
- If you change the value of *BufSize*, always set the value of *CurIndex* to 0 and initialize the stored values.
- An error occurs in the following cases. *ENO* will be FALSE, and *Out* will not change.
 - The value of *BufSize* exceeds the size of the *Buf[]* array.

Sample Programming

This sample shows how to eliminate the effect of noise and other disturbances in analog input data, e.g., from a sensor. It assigns the average (*DataAve*) of the last 25 values of the input data (*InputData*) to the input data (*InputDataForOperating*) for the next process.

InputData is input every task period as long as the value of the execution condition (*Trigger*) is TRUE. Until 25 values of *InputData* are input, there is not enough data to calculate the average, so the most recent value of *InputData* is assigned to *InputDataForOperating*.

When the value of *Trigger* changes to TRUE, the average is cleared and input of *InputData* is started again from the beginning.

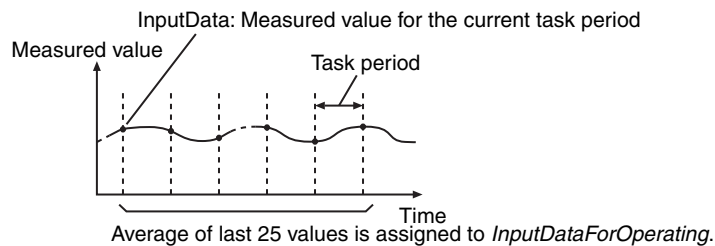

LD

Variable	Data type	Initial value	Comment
Trigger	BOOL	FALSE	Execution condition
InputData	INT	10	Input value
Buffer	ARRAY[0..24] OF INT	[25(0)]	Input value storage array
DataAve	INT	0	Average value
OneRound	BOOL	FALSE	Flag that indicates 25 inputs
IndexNo	UINT	0	Input value storage position
InputDataForOperating	INT	0	Input to next operation

When *Trigger* changes to TRUE, 0 is assigned to *IndexNo*.
While *Trigger* is TRUE, the value of *InputData* is input every task period and the average is calculated.

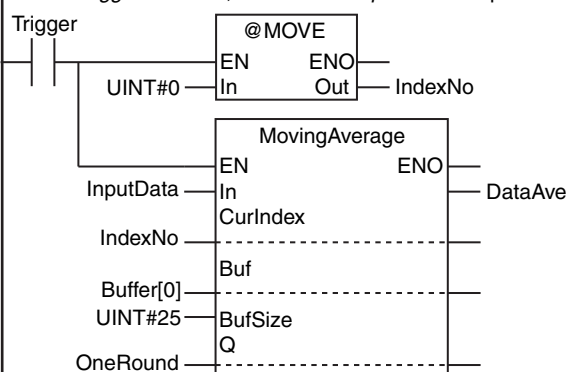

When there are 25 or more input values for *InputData*, *DataAve* is assigned to *InputDataForOperating*.

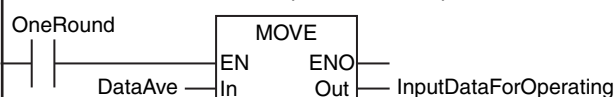

Until there are 25 or more input values for *InputData*, *InputData* is assigned to *InputDataForOperating*.

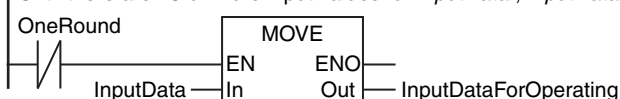

ST

Variable	Data type	Initial value	Comment
Trigger	BOOL	FALSE	Execution condition
LastTrigger	BOOL	FALSE	Value of <i>Trigger</i> from previous task period
Operating	BOOL	FALSE	Processing
OperatingStart	BOOL	FALSE	Processing started
Buffer	ARRAY[0..24] OF INT	[25(0)]	Input value storage array
InputData	INT	10	Input value
DataAve	INT	0	Average value
OneRound	BOOL	FALSE	Flag that indicates 25 inputs
IndexNo	UINT	0	Input value storage position
InputDataFor Operating	INT	0	Input to next operation

```

// Detect when Trigger changes to TRUE.
IF ( (Trigger=TRUE) AND (LastTrigger=FALSE) ) THEN
    OperatingStart:=TRUE;
    Operating:=TRUE;
END_IF;
LastTrigger:=Trigger;

// Clear the average.
IF (OperatingStart=TRUE) THEN
    IndexNo:=UINT#0;
    OperatingStart:=FALSE;
END_IF;

// Calculate the moving average.
IF (Operating=TRUE) THEN
    DataAve:=MovingAverage(
        In      :=InputData,
        CurIndex:=IndexNo,
        Buf     :=Buffer[0],
        BufSize :=UINT#25,
        Q       :=OneRound);

    IF (OneRound=TRUE) THEN
        // Assign the average of last 25 values to InputDataForOperating.
        InputDataForOperating:=DataAve;
    ELSE
        // Assign the most recent value to InputDataForOperating.
        InputDataForOperating:=InputData;
    END_IF;
END_IF;

// End average processing.
IF (Trigger=FALSE) THEN
    Operating:=FALSE;
END_IF;

```

DispartReal

The DispartReal instruction separates a real number into the signed mantissa and the exponent.

Instruction	Name	FB/FUN	Graphic expression	ST expression
DispartReal	Separate Mantissa and Exponent	FUN		Out:=DispartReal(In, Fraction, Exponent);

Variables

Name	Meaning	I/O	Description	Valid range	Unit	Default
In	Real number	Input	Real number to separate	Depends on data type.	---	*1
Out	Return value	Output	Always TRUE	TRUE only	---	---
Fraction	Signed mantissa		Signed mantissa	*2		
Exponent	Exponent		Exponent	*3		

*1 If you omit the input parameter, the default value is not applied. A building error will occur.

*2 The valid ranges depend on the data types of *In* and *Fraction*. Refer to *Function* for details.

*3 If *In* is REAL data, -44 to 32. If *In* is LREAL data, -322 to 294

	Boolean	Bit strings				Integers							Real numbers		Times, durations, dates, and text strings					
	BOOL	BYTE	WORD	DWORD	LWORD	USINT	UINT	UDINT	ULINT	SINT	INT	DINT	LINT	REAL	LREAL	TIME	DATE	TOD	DT	STRING
In														OK	OK					
Out	OK																			
Fraction	Must be DINT if the data type of <i>In</i> is REAL and LINT if the data type of <i>In</i> is LREAL.																			
Exponent										OK										

Function

The DispartReal instruction separates real number *In* into signed mantissa *Fraction* and exponent *Exponent*.

If *In* is REAL data, *Fraction* is a 7-digit integer. If *In* is LREAL data, *Fraction* is a 15-digit integer.

The following example is for when *In* is REAL data with a value of REAL#-123.456.

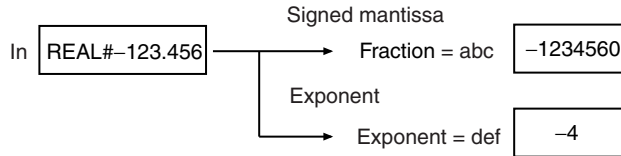
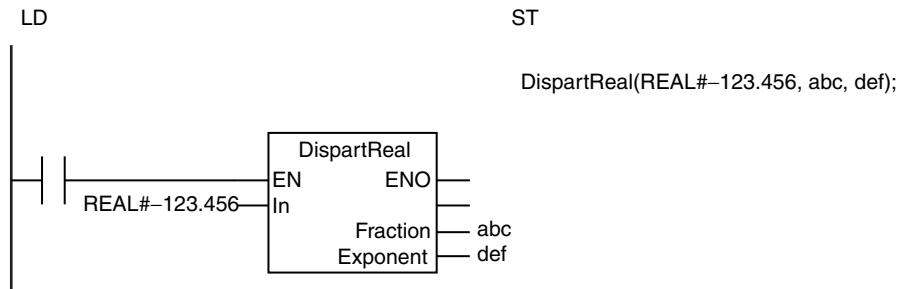

The following example is for when *In* is LREAL data with a value of LREAL#-123.456789.

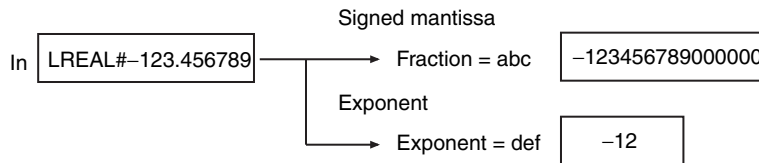
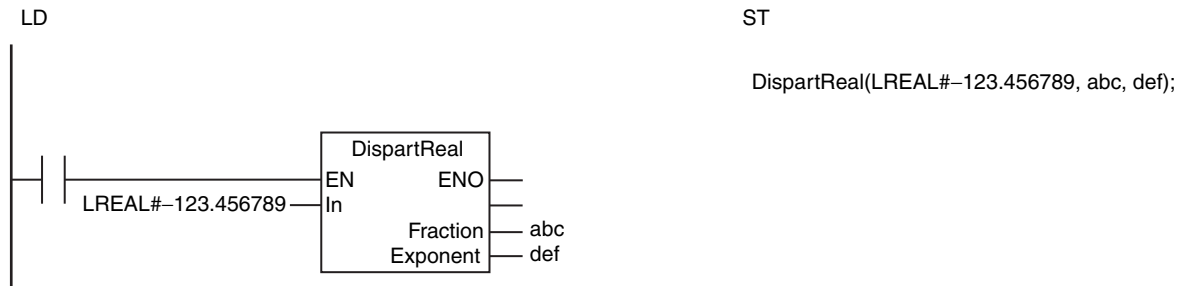

The following table shows the valid ranges for *Fraction* according to the data types *In* and *Fraction*.

Data type of <i>In</i>	Data type of <i>Fraction</i>	Valid range of <i>Fraction</i>
REAL	DINT	-9999999 to 9999999
LREAL	LINT	-9999999999999999 to 9999999999999999

Additional Information

Use the UniteReal instruction (page 2-444) to combine a signed mantissa and exponent to form a real number.

Precautions for Correct Use

- Depending on the value of *In*, error may occur in the conversion to an integer.

- If the number of valid digits in *In* exceeds the number of valid digits of *Fraction*, the value is rounded to fit in the valid range of *Fraction*. The following table shows how values are rounded.

Value of fractional part	Treatment	Examples
Less than 0.5	The fractional part is truncated.	1.49 → 1 -1.49 → -1
0.5	If the ones digit is an even number, the value is truncated. If it is an odd number, the value is rounded up.	1.50 → 2 2.50 → 2 -1.50 → -2 -2.50 → -2
Greater than 0.5	The fractional part is rounded up.	1.51 → 2 -1.51 → -2

- An error occurs in the following case. *ENO* will be FALSE, and *Fraction* and *Exponent* will not change.
 - The value of *In* is nonnumeric or infinity.

UniteReal

The UniteReal instruction combines a signed mantissa and exponent to make a real number.

Instruction	Name	FB/FUN	Graphic expression	ST expression
UniteReal	Combine Real Number Mantissa and Exponent	FUN		Out:=UniteReal(Fraction, Exponent);

Variables

Name	Meaning	I/O	Description	Valid range	Unit	Default
Fraction	Signed mantissa	Input	Signed mantissa	Depends on data type.	---	*
Exponent	Exponent		Exponent			0
Out	Real number	Output	Real number	Depends on data type.	---	---

* If you omit the input parameter, the default value is not applied. A building error will occur.

	Boolean	Bit strings					Integers							Real numbers		Times, durations, dates, and text strings				
	BOOL	BYTE	WORD	DWORD	LWORD	USINT	UINT	UDINT	ULINT	SINT	INT	DINT	LINT	REAL	LREAL	TIME	DATE	TOD	DT	STRING
Fraction												OK	OK							
Exponent										OK										
Out	Must be REAL if the data type of <i>Fraction</i> is DINT and LREAL if the data type of <i>Fraction</i> is LINT.																			

Function

The UniteReal instruction combines signed mantissa *Fraction* and exponent *Exponent* to make real number *Out*.

The following example is for when *Fraction* is DINT#-15 and *Exponent* is INT#-1.

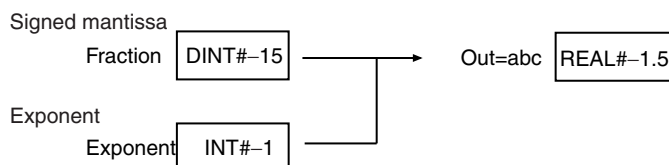
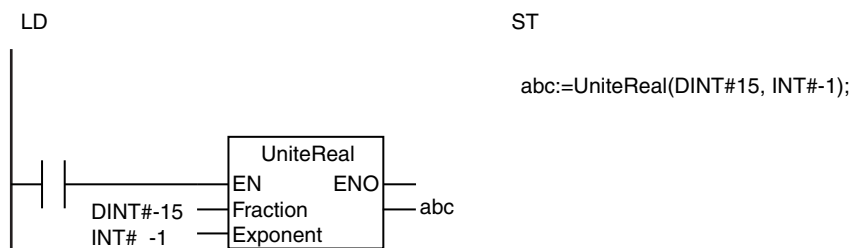

Additional Information

Use the DispartReal instruction (page 2-441) to separate a real number into the signed mantissa and exponent.

Precautions for Correct Use

- Depending on the values of *Fraction* and *Exponent*, error may occur in the conversion from an integer to a real number.
- If the combined result exceeds the valid range of *Out* and *Exponent* is positive, the value of *Out* will be infinity with the same sign as *Fraction*. If *Exponent* is negative, the value of *Out* will be 0.

NumToDecString and NumToHexString

NumToDecString: Converts an integer to a fixed-length decimal text string.

NumToHexString: Converts an integer to a fixed-length hexadecimal text string.

Instruction	Name	FB/FUN	Graphic expression	ST expression
NumToDecString	Fixed-length Decimal Text String Conversion	FUN		Out:=NumToDecString(In, L, Fill);
NumToHexString	Fixed-length Hexadecimal Text String Conversion	FUN		Out:=NumToHexString(In, L, Fill);

Variables

Name	Meaning	I/O	Description	Valid range	Unit	Default
In	Integer	Input	Integer	Depends on data type.	---	*
L	Number of characters		Number of characters in <i>Out</i>	0 to 1985		1
Fill	Fill character		Fill character	_BLANK or _ZERO		_BLANK
Out	Text string	Output	Text string	Depends on data type.	---	---

* If you omit the input parameter, the default value is not applied. A building error will occur.

	Boolean	Bit strings					Integers							Real numbers	Times, durations, dates, and text strings					
	BOOL	BYTE	WORD	DWORD	LWORD	USINT	UINT	UDINT	ULINT	SINT	INT	DINT	LINT	REAL	LREAL	TIME	DATE	TOD	DT	STRING
In						OK	OK	OK	OK	OK	OK	OK								
L							OK													
Fill	Refer to <i>Function</i> for the enumerators for the enumerated type <code>_eFILL_CHR</code> .																			
Out																				OK

Function

● NumToDecString

The NumToDecString instruction converts integer *In* to a decimal text string of UTF-8 alphanumeric characters. If *In* contains a negative value, a minus sign (–) is added to the front of the text string.

● NumToHexString

The NumToHexString instruction converts integer *In* to a hexadecimal text string of UTF-8 alphanumeric characters. If *In* is negative, it is expressed in its two's complement (bits inverted and then 1 added).

For either instruction, the number of characters in text string *Out* is adjusted to number of characters *L*. If there are not enough characters, the upper digits are filled with fill character *Fill*. If the number of characters in the conversion result exceeds *L*, *L* characters from the lower digits of the conversion result are assigned to *Out*. The NULL character is not included in the number of characters.

The data type of *Fill* is enumerated type `_eFILL_CHR`. The meaning of the enumerators are as follows:

Enumerator	Meaning
<code>_BLANK</code>	" (blank character)
<code>_ZERO</code>	'0'

The following examples are for the NumToDecString instruction.

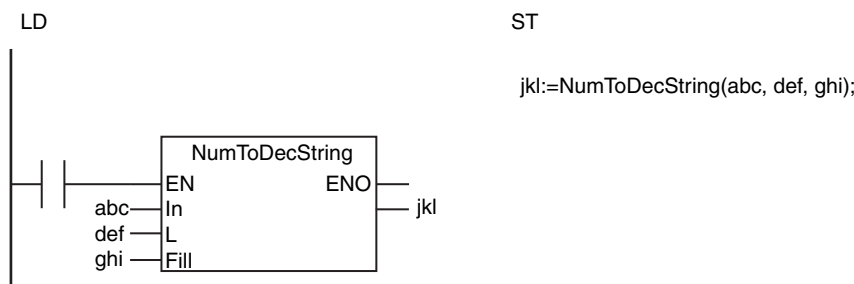

In = abc = INT#128, L = def = UINT#8, Fill = ghi = `_BLANK`
 Out = jkl | | | | | 1 2 8

In = abc = INT#-128, L = def = UINT#8, Fill = ghi = `_BLANK`
 Out = jkl | | | | | - 1 2 8

In = abc = INT#-128, L = def = UINT#8, Fill = ghi = `_ZERO`
 Out = jkl | 0 0 0 0 | 1 2 8

The following examples are for the NumToHexString instruction.

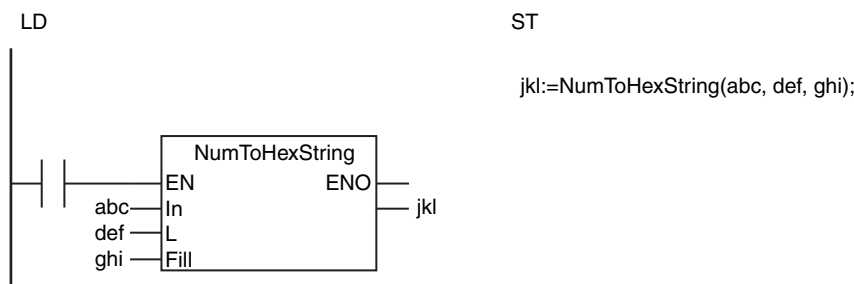

In = abc = INT#128, L = def = UINT#8, Fill = ghi = `_BLANK`
 Out = jkl | | | | | 8 0

In = abc = INT#128, L = def = UINT#8, Fill = ghi = `_ZERO`
 Out = jkl | 0 0 0 0 | 0 8 0

In = abc = INT#-128, L = def = UINT#8, Fill = ghi = `_BLANK`
 Out = jkl | F F F F F F | 8 0

Precautions for Correct Use

- If the value of *L* is 0, *Out* is a text string containing only the NULL character.
- If the number of characters in the conversion result exceeds the value of *L*, *L* characters from the lower characters of the conversion result are stored in *Out*. The following is an example.

Instruction	Value of <i>In</i>	Value of <i>L</i>	Value of <i>Out</i>
NumToDecString	128	2	28
NumToHexString			80

- An error occurs in the following cases. *ENO* will be FALSE, and *Out* will not change.
 - The value of *L* is outside of the valid range.
 - The value of *Fill* is outside of the valid range.

Precautions for Correct Use

- Even if the conversion result exceeds the valid range of *Out*, an error will not occur. The value of *Out* will be an illegal value.
- An error occurs in the following cases. *ENO* will be FALSE, and *Out* will not change.
 - The content of *In* includes characters that cannot be converted to numbers.

FixNumToString

The FixNumToString instruction converts a signed fixed-decimal number to a decimal text string.

Instruction	Name	FB/FUN	Graphic expression	ST expression
FixNumToString	Fixed-decimal Number-to-Text String Conversion	FUN		Out:=FixNumToString(In, Zero);

Variables

Name	Meaning	I/O	Description	Valid range	Unit	Default
In	Fixed-decimal number	Input	Signed fixed-decimal number	Depends on data type.	---	0
Zero	Zero augmentation		Augmentation of zeros if there are less than 3 decimal digits TRUE: Add '0' FALSE: Do not add '0'			TRUE
Out	Decimal text string	Output	Decimal text string	Depends on data type.	---	---

	Boolean	Bit strings				Integers						Real numbers	Times, durations, dates, and text strings							
	BOOL	BYTE	WORD	DWORD	LWORD	USINT	UINT	UDINT	ULINT	SINT	INT	DINT	LINT	REAL	LREAL	TIME	DATE	TOD	DT	STRING
In				OK																
Zero	OK																			
Out																				OK

Function

The FixNumToString instruction converts signed fixed-decimal number *In* to a decimal text string. The following conversion is used.

1 The hexadecimal number *In* is converted to a decimal number.

2 The result is divided by 1,000.

Zero augmentation *Zero* specifies whether to add '0' to the third decimal place of *Out* when there are less than three decimal digits in *In*. If the value of *Zero* is TRUE, '0' is added. A NULL character is placed at the end of *Out*.

A few examples are given below.

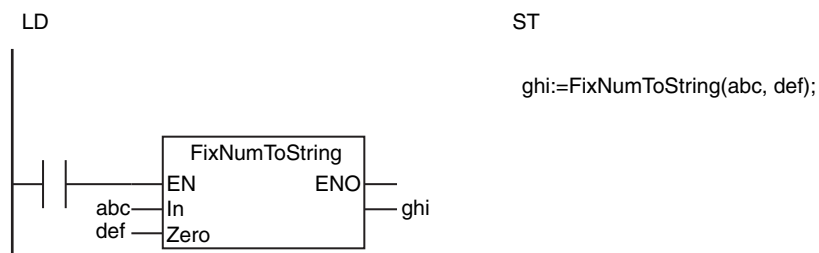

<i>In = abc</i>	<i>Out = ghi</i>	
	<i>Zero = def = TRUE</i>	<i>Zero = def = FALSE</i>
16#0001462C (10#83500)	'83.500'	'83.5'
16#00051AA4 (10#334500)	'334.500'	'334.5'
16#0003BEFC (10#245500)	'245.500'	'245.5'

Additional Information

The format for fixed-point decimal numbers is the same as the fixed-decimal output format of the OMRON FZ-series Vision Sensors.

StringToFixNum

The StringToFixNum instruction converts a decimal text string to a signed fixed-decimal number.

Instruction	Name	FB/FUN	Graphic expression	ST expression
StringToFixNum	Text String-to-Fixed-decimal Conversion	FUN		Out:=StringToFixNum(In);

Variables

Name	Meaning	I/O	Description	Valid range	Unit	Default
In	Decimal text string	Input	Decimal text string	Depends on data type.	---	"
Out	Fixed-decimal number	Output	Fixed-decimal number	Depends on data type.	---	---

	Boolean	Bit strings				Integers								Real numbers	Times, durations, dates, and text strings					
	BOOL	BYTE	WORD	DWORD	LWORD	USINT	UINT	UDINT	ULINT	SINT	INT	DINT	LINT	REAL	LREAL	TIME	DATE	TOD	DT	STRING
In																				OK
Out				OK																

Function

The StringToFixNum instruction converts decimal text string *In* to a fixed-decimal number. The following conversion is used.

- 1** The number in *In* is multiplied by 1,000.
- 2** The fractional part is truncated.
- 3** The result is given as a 32-bit hexadecimal number (DWORD).

A few examples are given below.

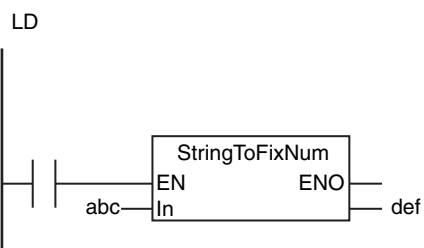

ST

```
def:=StringToFixNum(abc);
```

In = abc	Out = def
'83.5'	16#0001462C (10#83500)
'334.5'	16#00051AA4 (10#334500)
'245.5'	16#0003BEFC (10#245500)

The format of the text sting in *In* is given below.

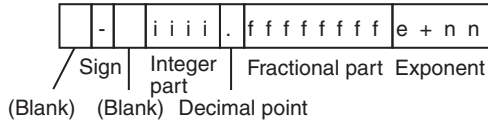

Name	Format
Sign	<ul style="list-style-type: none"> Any consecutive blank characters (16#20) at the beginning of the text string are ignored. Any single plus or minus sign that follows is treated as the sign. The sign can be omitted. Any consecutive blank characters after the sign are ignored.
Integer part	<ul style="list-style-type: none"> Consecutive numbers ('0' to '9') after the sign and up to the decimal point are taken as the integer part. The sign may sometimes be omitted. There may be blank characters between the sign and the integer part. If the decimal point and fractional part are omitted, the characters up to the exponent are taken as the integer part. If the decimal point, fractional part, and exponent are omitted, the characters up to the end of the text string are taken as the integer part. The integer part cannot be omitted. The maximum number of digits in the integer part is the maximum text string length of 1986 minus the total number of bytes in the following: the sign, decimal point, fractional part, exponent, and blank characters before and after the sign.
Decimal point	<ul style="list-style-type: none"> A single dot ('.') following the integer part is taken as the decimal point. Omit the decimal point if there is no fractional part.
Fractional part	<ul style="list-style-type: none"> Consecutive numbers ('0' to '9') after the decimal point and up to the exponent are taken as the fractional part. If the exponent is omitted, the characters up to the end of the text string are taken as the fractional part. The fractional part can be omitted. If there is no decimal point, then there is no fractional part. The fractional part can consist of a maximum of 15 digits.
Exponent	<ul style="list-style-type: none"> The exponent consists of a single 'e' or 'E' after the fractional part, a following single plus or minus sign, and the remaining continuous numbers ('0' to '9') to the end of the text string. If there is no fractional part, then the above text string after the decimal point is taken as the exponent. If there is no decimal point or fractional part, then the above text string after the integer part is taken as the exponent. The exponent can be omitted. The numeric part of the exponent can consist of a maximum of three digits.

Example 1: The following example uses the sign, decimal point, and fractional part, but does not use an exponent.

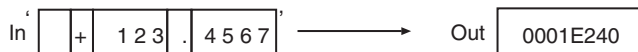

Example 2: The following example uses the sign, decimal point, fractional part, and exponent.

In

+	1	.	2	3	4	5	6	7	e	+	0	2
---	---	---	---	---	---	---	---	---	---	---	---	---

 → Out

0001E240

Example 3: The following example does not use the sign, but uses the decimal point, fractional part, and exponent.

In

1	2	3	4	5	.	6	7	e	-	0	2
---	---	---	---	---	---	---	---	---	---	---	---

 → Out

0001E240

Example 4: The following example does not use the sign, fractional part, decimal point, and exponent.

In

1

 → Out

00003E8

Additional Information

The format for fixed-point decimal numbers is the same as the fixed-decimal output format of the OMRON FZ-series Vision Sensors.

Precautions for Correct Use

- The digits after the third decimal digit are truncated in *In*.
- Underbars (16#5F) in the text string in *In* are ignored.
- An error occurs in the following cases. *ENO* will be FALSE, and *Out* will not change.
 - The content of *In* includes characters that cannot be converted to numbers.
 - The content of *In* has a decimal point but not a fractional part.

DtToString

The DtToString instruction converts a date and time to a text string.

Instruction	Name	FB/FUN	Graphic expression	ST expression
DtToString	Date and Time-to-Text String Conversion	FUN		Out:=DtToString(In);

Variables

Name	Meaning	I/O	Description	Valid range	Unit	Default
In	Date and time	Input	Date and time	Depends on data type.	Year, month, day, hour, minutes, seconds	DT#1970-1-1-0:0:0
Out	Text string	Output	Text string	30 bytes (29 single-byte alphanumeric characters plus the final NULL character)	---	---

	Boolean	Bit strings					Integers						Real numbers		Times, durations, dates, and text strings						
		BOOL	BYTE	WORD	DWORD	LWORD	USINT	UINT	UDINT	ULINT	SINT	INT	DINT	LINT	REAL	LREAL	TIME	DATE	TOD	DT	STRING
In																				OK	
Out																					OK

Function

The DtToString instruction converts date and time *In* to a text string. A NULL character is placed at the end of text string *Out*.

An example when *In* is 2010-5-23-07:00:15.873232345 (7:00 am and 15.873232345 seconds on May 23, 2010) is given below. The value of variable *abc* will be '2010-05-23-07:00:15.873232345'.

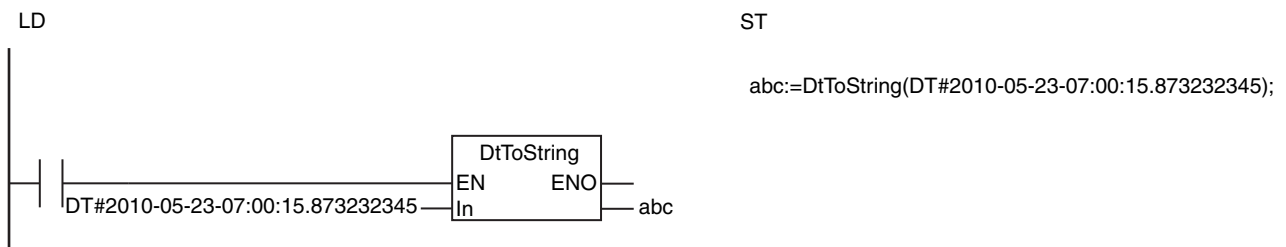

The DtToString instruction converts date and time *In* to a text string. The value of *In* is 7:00 am and 15.873232345 seconds on May 23, 2010, so the value of *abc* will be '2010-05-23-07:00:15.873232345'.

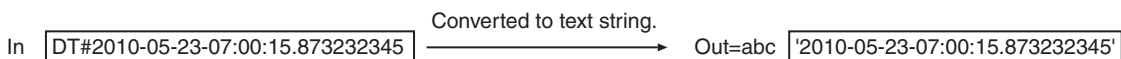

Additional Information

Out is in nanoseconds. To get a text string in seconds or milliseconds, combine this instruction with the LEFT or RIGHT instruction (page 2-550).

An example to get a text string in seconds is given below.

- LD

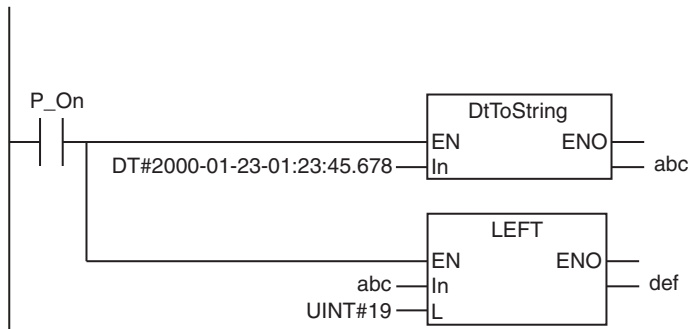

- ST

```
def:=LEFT(DtToString(DT#2000-01-23-01:23:45.678), UINT#19);
```

DateToString

The DateToString instruction converts a date to a text string.

Instruction	Name	FB/FUN	Graphic expression	ST expression
DateToString	Date-to-Text String Conversion	FUN		Out:=DateToString(In);

Variables

Name	Meaning	I/O	Description	Valid range	Unit	Default
In	Date	Input	Date	Depends on data type.	Year, month, day	D#1970-1-1
Out	Text string	Output	Text string	11 bytes (10 single-byte alphanumeric characters plus the final NULL character)	---	---

	Boolean	Bit strings					Integers							Real numbers	Times, durations, dates, and text strings					
	BOOL	BYTE	WORD	DWORD	LWORD	USINT	UINT	UDINT	ULINT	SINT	INT	DINT	LINT	REAL	LREAL	TIME	DATE	TOD	DT	STRING
In																	OK			
Out																				OK

Function

The DateToString instruction converts date *In* to a text string. A NULL character is placed at the end of *Out*.

An example when *In* is 2010-5-23 (May 23, 2010) is given below. The value of variable *abc* will be '2010-05-23'.

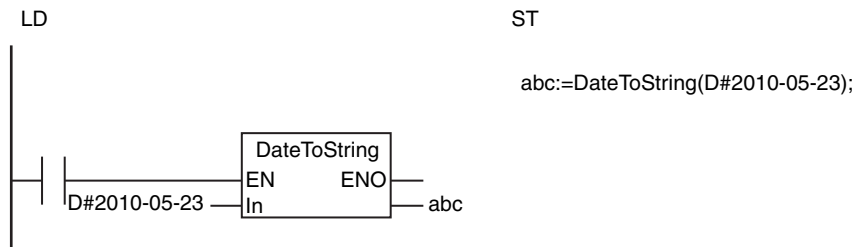

The DateToString instruction converts date *In* to a text string. The value of *In* is May 23, 2010, so the value of *abc* will be '2010-05-23'.

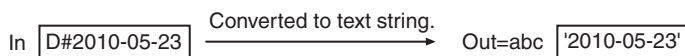

TodToString

The TodToString instruction converts a time of day to a text string.

Instruction	Name	FB/FUN	Graphic expression	ST expression
TodToString	Time of Day-to-Text String Conversion	FUN		Out:=TodToString(In);

Variables

Name	Meaning	I/O	Description	Valid range	Unit	Default
In	Time of day	Input	Time of day	Depends on data type.	Hour, minutes, seconds	TOD#0:0:0
Out	Text string	Output	Text string	19 bytes (18 single-byte alphanumeric characters plus the final NULL character)	---	---

	Boolean	Bit strings					Integers							Real numbers		Times, durations, dates, and text strings				
	BOOL	BYTE	WORD	DWORD	LWORD	USINT	UINT	UDINT	ULINT	SINT	INT	DINT	LINT	REAL	LREAL	TIME	DATE	TOD	DT	STRING
In																		OK		
Out																				OK

Function

The TodToString instruction converts time of day *In* to a text string. A NULL character is placed at the end of *Out*. An example when *In* is 07:00:15.873232345 (7:00 am and 15.873232345 seconds) is given below. The value of variable *abc* will be '07:00:15.873232345'.

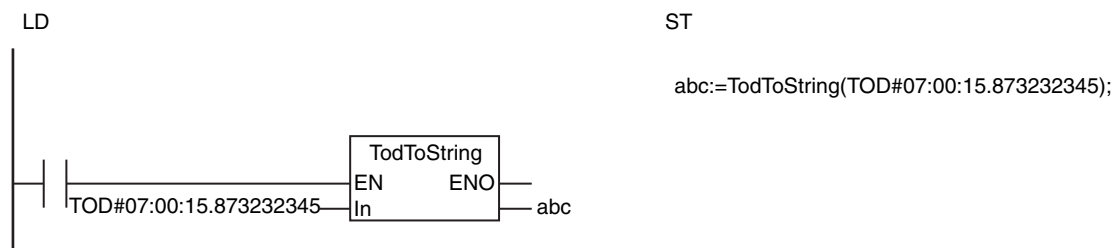

The TodToString instruction converts time of day *In* to a text string. The value of *In* is 7:00 am and 15.873232345 seconds, so the value of *abc* will be '07:00:15.873232345'.

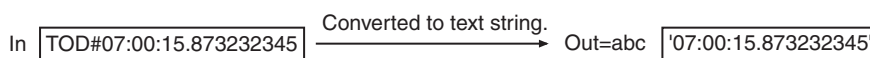

Additional Information

Out is in nanoseconds. To get a text string in seconds or milliseconds, combine this instruction with the LEFT or RIGHT instruction (page 2-550).

An example to get a text string in seconds is given below.

- LD

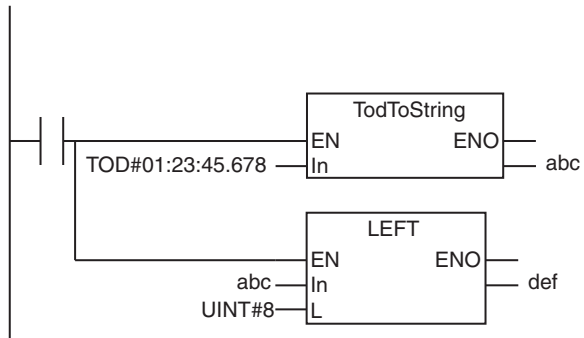

- ST

```
def:=LEFT(TodToString(TOD#01:23:45.678), UINT#8);
```

GrayToBin_** and BinToGray_**

GrayToBin_**: Converts a gray code to a bit string.

BinToGray_**: Converts a bit string to a gray code.

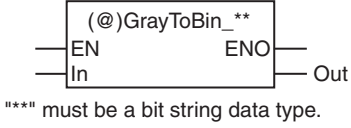
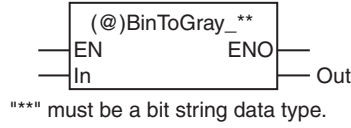
Instruction	Name	FB/FUN	Graphic expression	ST expression
GrayToBin_**	Gray Code-to-Binary Code Conversion Group	FUN		Out:=GrayToBin_**(In); "*** must be a bit string data type.
BinToGray_**	Binary Code-to-Gray Code Conversion	FUN		Out:=BinToGray_**(In); "*** must be a bit string data type.

Variables

Name	Meaning	I/O	Description	Valid range	Unit	Default
In	Data to convert	Input	Data to convert	Depends on data type.	---	0
Out	Conversion result	Output	Conversion result	Depends on data type.	---	---

	Boolean	Bit strings				Integers						Real numbers	Times, durations, dates, and text strings							
	BOOL	BYTE	WORD	DWORD	LWORD	USINT	UINT	UDINT	ULINT	SINT	INT	DINT	LINT	REAL	LREAL	TIME	DATE	TOD	DT	STRING
In		OK	OK	OK	OK															
Out	Must be same data type as <i>In</i>																			

Function

● GrayToBin_**

The GrayToBin_** instructions convert the gray code in date to convert *In* to a bit string. The conversion procedure is as follows for when *In* and *Out* are BYTE data.

- 1** The most-significant bit (bit 7) of *In* is used as is as the most-significant bit (bit 7) of *Out*.
- 2** An exclusive logical OR is taken of the value of bit 6 in *In* and the value of bit 7 in *Out*. The result is used as bit 6 of *Out*.
- 3** This process is repeated through the least-significant bit (bit 0) of *Out*.

The following example for the GrayToBin_BYTE instruction is for when *In* is BYTE#16#A5.

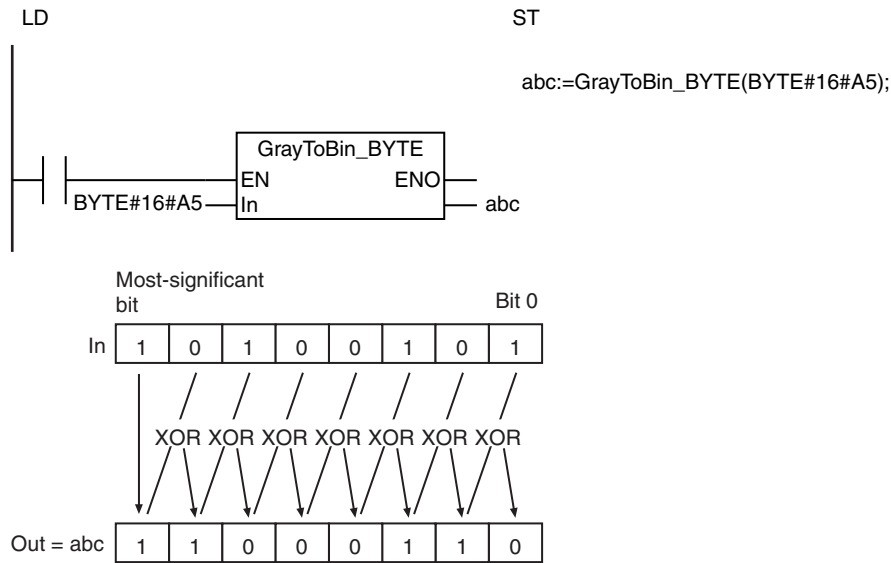

● BinToGray_**

The BinToGray_** instructions convert the bit string in data to convert *In* to a gray code. The conversion procedure is as follows for when *In* and *Out* are BYTE data.

- 1** The most-significant bit (bit 7) of *In* is used as is as the most-significant bit (bit 7) of *Out*.
- 2** An exclusive logical OR is taken of the value of bit 7 in *In* and the value of bit 6 in *In*. The result is used as bit 6 of *Out*.
- 3** This process is repeated through the least-significant bit (bit 0) of *Out*.

The following example for the BinToGray_BYTE instruction is for when *In* is BYTE#16#C6.

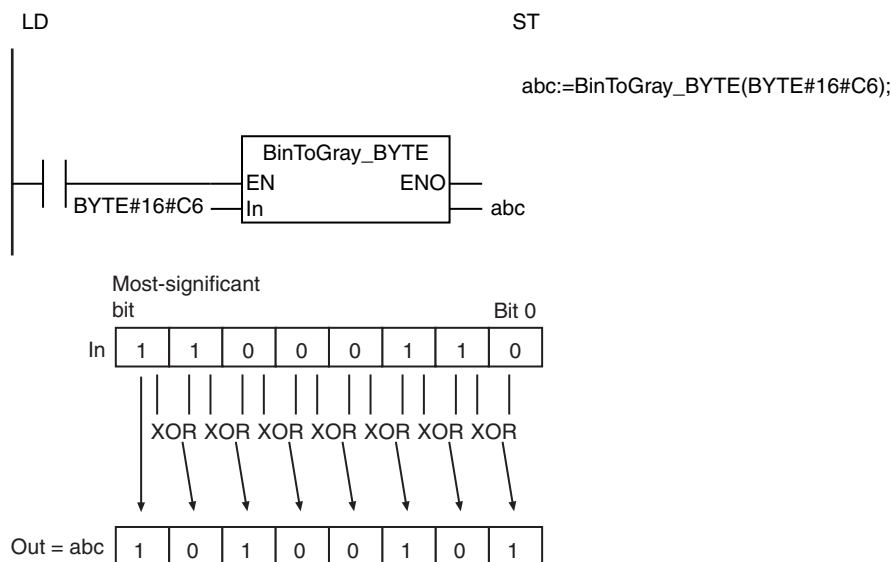

The name of the instruction is determined by the data types of *In* and *Out*. For example, if *In* and *Out* are the WORD data type, the instruction is GrayToBin_WORD or BinToGray_WORD.

Precautions for Correct Use

The data types of *In* and *Out* must be the same.

StringToAry

The StringToAry instruction converts a text string to a BYTE array.

Instruction	Name	FB/FUN	Graphic expression	ST expression
StringToAry	Text String-to-Array Conversion	FUN		Out:=StringToAry(In, AryOut);

Variables

Name	Meaning	I/O	Description	Valid range	Unit	Default
In	Text string	Input	Text string	Depends on data type.	---	"
AryOut[] (array)	BYTE array	In-out	BYTE array	Depends on data type.	---	---
Out	Number of bytes to convert	Output	Number of bytes to convert	0 to 1985	Bytes	---

	Boolean	Bit strings				Integers							Real numbers		Times, durations, dates, and text strings					
	BOOL	BYTE	WORD	DWORD	LWORD	USINT	UINT	UDINT	ULINT	SINT	INT	DINT	LINT	REAL	LREAL	TIME	DATE	TOD	DT	STRING
In																				OK
AryOut[] (array)		OK																		
Out							OK													

Function

The StringToAry instruction takes the character codes in text string *In* as numbers and stores them individually in a BYTE array, *AryOut[]*. The number of bytes that was converted is stored in *Out*.

The following example is for when *In* is 'XYZ'.

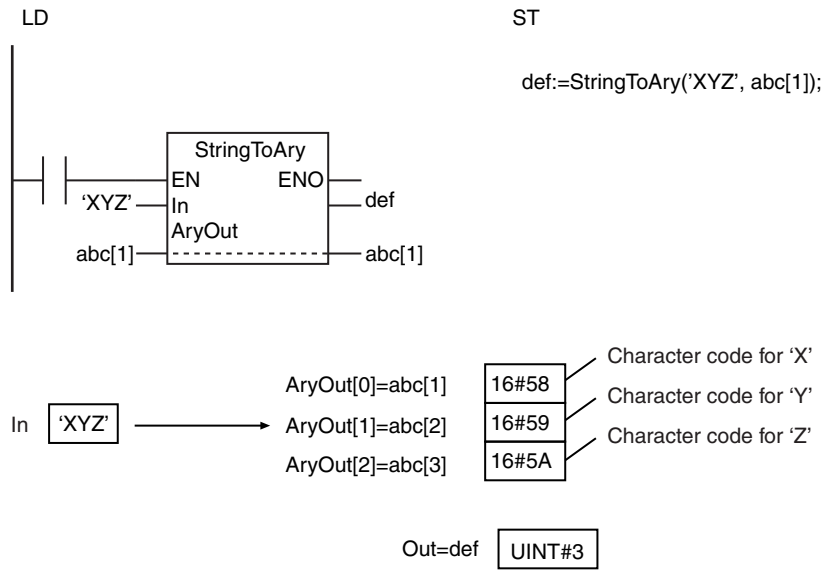

Precautions for Correct Use

- The NULL character at the end of *In* is not stored in *AryOut[]*.
- If the *In* text string contains only the NULL character, the value of *Out* will be 0 and *AryOut[]* will not change.
- An error occurs in the following cases. *ENO* will be FALSE, and *Out* and *AryOut[]* will not change.
 - The number of bytes in *In* is larger than the number of elements in *AryOut[]*.

AryToString

The AryToString instruction converts a BYTE array to a text string.

Instruction	Name	FB/FUN	Graphic expression	ST expression
AryToString	Array-to-Text String Conversion	FUN		Out:=AryToString(In, Size);

Variables

Name	Meaning	I/O	Description	Valid range	Unit	Default
In[] (array)	BYTE array	Input	BYTE array Maximum number of elements: 1985	Depends on data type.	---	*
Size	Number of elements to convert		Number of elements of <i>In[]</i> for conversion	0 to 1985		1
Out	Text string	Output	Text string	Depends on data type.	---	---

* If you omit the input parameter, the default value is not applied. A building error will occur.

	Boolean	Bit strings				Integers							Real numbers	Times, durations, dates, and text strings						
	BOOL	BYTE	WORD	DWORD	LWORD	USINT	UINT	UDINT	ULINT	SINT	INT	DINT	LINT	REAL	LREAL	TIME	DATE	TOD	DT	STRING
In[] (array)		OK																		
Size							OK													
Out																				OK

Function

The AryToString instruction takes the elements of a BYTE array, *In[]*, from *In[0]* as character codes and stores them in text string *Out*. A NULL character is placed at the end of *Out*. *Size* specifies the number of elements of *In[]* to convert. If there is a NULL character between *In[0]* and *In[Size-1]*, no character codes past it are stored in *Out*.

The following example is for when *Size* is *UINT#3*.

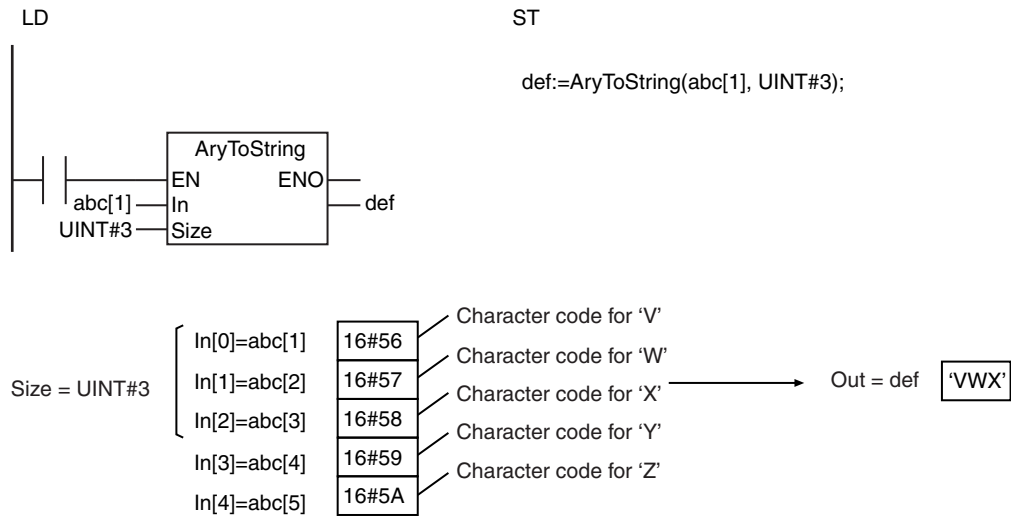

Precautions for Correct Use

- If the value of *Size* is 0, *Out* is a text string containing only the NULL character.
- An error occurs in the following cases. *ENO* will be FALSE, and *Out* will not change.
 - The value of *Size* exceeds the array area of *In[]*.

DispartDigit

The DispartDigit instruction separates a bit string into 4-bit units.

Instruction	Name	FB/FUN	Graphic expression	ST expression
DispartDigit	Four-bit Separation	FUN		DispartDigit(In, Num, AryOut);

Variables

Name	Meaning	I/O	Description	Valid range	Unit	Default
In	Data to separate	Input	Bit string to separate	Depends on data type.	---	*
Num	Number of digits to separate		Number of digits to separate	0 to No. of bits in <i>In</i>		1
AryOut[] (array)	Separation results array	In-out	Separation results array	16#00 to 16#0F	---	---
Out	Return value	Output	Always TRUE	TRUE only	---	---

* If you omit the input parameter, the default value is not applied. A building error will occur.

	Boolean	Bit strings				Integers							Real numbers	Times, durations, dates, and text strings						
	BOOL	BYTE	WORD	DWORD	LWORD	USINT	UINT	UDINT	ULINT	SINT	INT	DINT	LINT	REAL	LREAL	TIME	DATE	TOD	DT	STRING
In		OK	OK	OK	OK															
Num						OK														
AryOut[] (array)		OK																		
Out	OK																			

Function

The DispartDigit instruction separates data to separate *In* into 4-bit units (digits) and stores them in separation results array *AryOut[]*.

First, *In* is separated into 4-bit units. Then, the lowest 4 bits are stored in *AryOut[0]*. *AryOut[0]* is BYTE data, so 16#0 is stored in bits 4 to 7. This process is repeated for the number of digits that is specified in number of digits to separate *Num*.

The following example is for when *Num* is USINT#3.

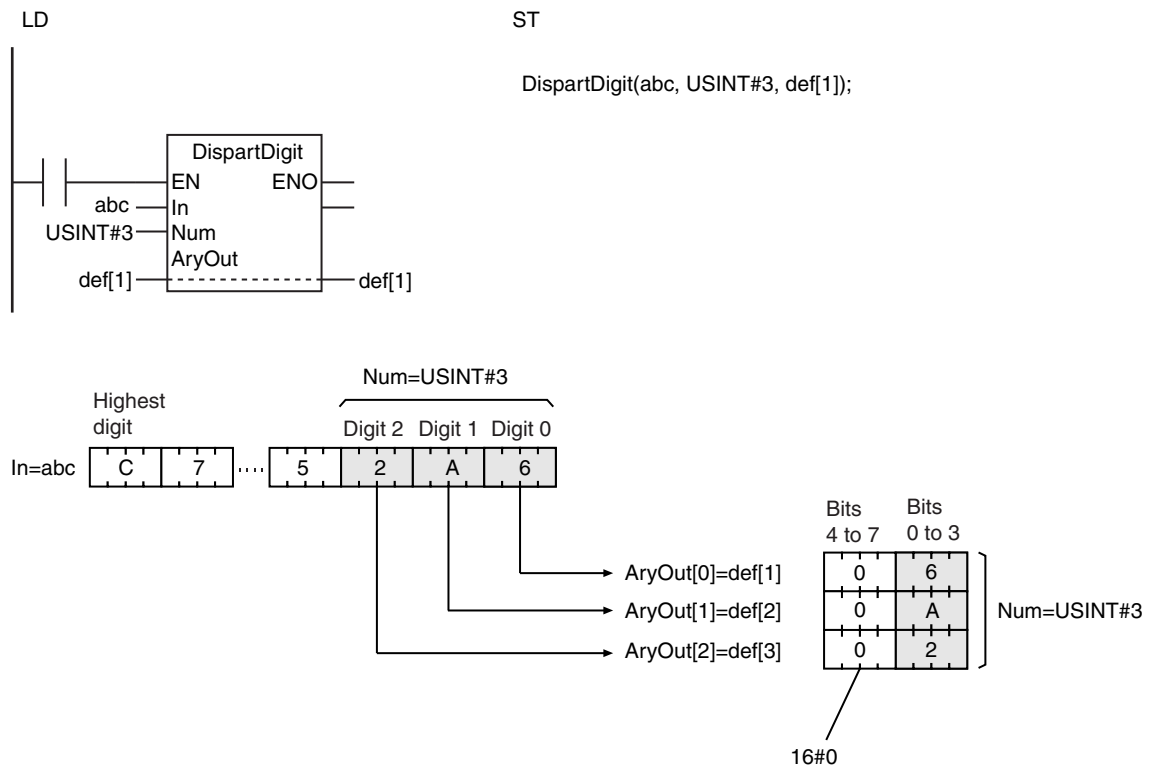

Additional Information

Use the `Unitedigit_**` instruction (page 2-469) to join 4-bit units from array elements.

Precautions for Correct Use

- The values in *AryOut*[] do not change if the value of *Num* is 0.
- Return value *Out* is not used when the instruction is used in ST.
- An error occurs in the following cases. *ENO* will be FALSE, and *AryOut*[] will not change.
 - The value of *Num* is outside of the valid range.
 - The value of *Num* exceeds the array area of *AryOut*[].

UniteDigit_**

The UniteDigit_** instructions join 4-bit units of data into a bit string.

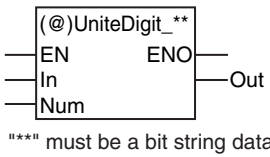
Instruction	Name	FB/FUN	Graphic expression	ST expression
UniteDigit_**	Four-bit Join Group	FUN		Out:=UniteDigit_**(In, Num); "****" must be a bit string data type.

Variables

Name	Meaning	I/O	Description	Valid range	Unit	Default
In[] (array)	Array to join	Input	Array to join	Depends on data type.	---	*
Num	Number of digits to join		Number of digits to join	0 to No. of bits in <i>Out</i>		1
Out	Joined result	Output	Bit string with joined result	Depends on data type.	---	---

* If you omit the input parameter, the default value is not applied. A building error will occur.

	Boolean	Bit strings				Integers							Real numbers	Times, durations, dates, and text strings						
	BOOL	BYTE	WORD	DWORD	LWORD	USINT	UINT	UDINT	ULINT	SINT	INT	DINT	LINT	REAL	LREAL	TIME	DATE	TOD	DT	STRING
In[] (array)		OK																		
Num						OK														
Out		OK	OK	OK	OK															

Function

The UniteDigit_** instructions join 4-bit units from the elements of array to join *In[]*. It creates a bit string in joined result *Out*. (Four bits is one digit.)

Number of digits to join *Num* specifies the number of array elements to join. First, the lower four bits from each element from *In[0]* to *In[Num-1]* are joined to create a bit string with *Num* digits. To this, 16#0 is added to the upper digits for the number of digits of *Out* minus the value of *Num*. The result is stored in *Out*.

The name of the instruction is determined by the data type of *Out*. For example, if *Out* is the WORD data type, the instruction is UniteDigit_WORD.

The following example shows the UniteDigit_WORD instruction when *Num* is USINT#3.

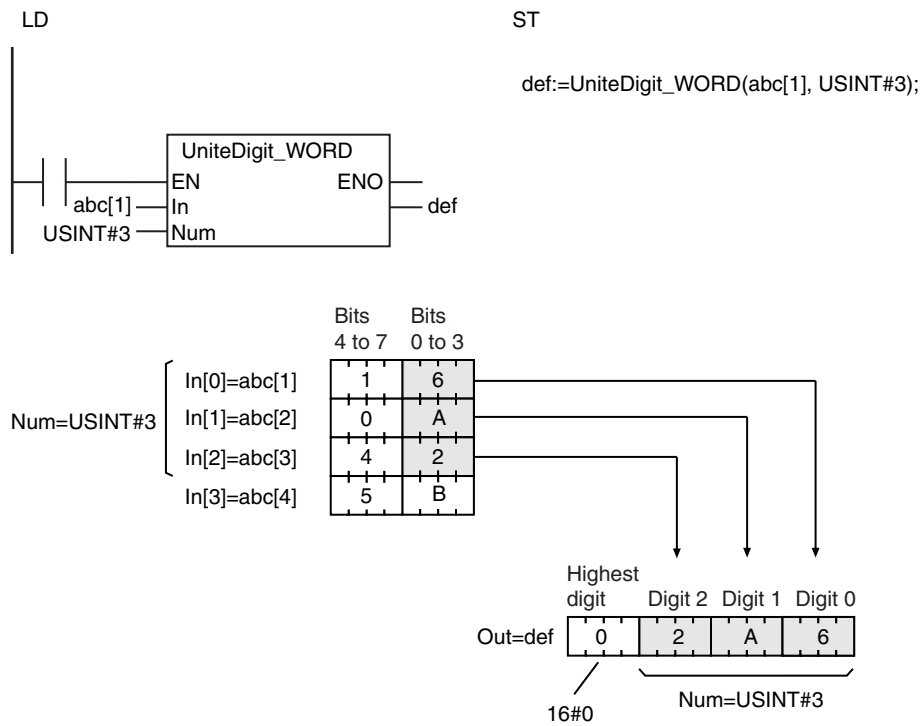

Additional Information

Use the DispartDigit instruction (page 2-467) to separate a bit string into 4-bit units.

Precautions for Correct Use

- If the value of *Num* is 0, the value of *Out* is 0.
- An error occurs in the following cases. *ENO* will be FALSE, and *Out* will not change.
 - The value of *Num* is outside of the valid range.
 - The value of *Num* exceeds the array area of *In[]*.

Dispart8Bit

The Dispart8Bit instruction separates a bit string into individual bytes.

Instruction	Name	FB/FUN	Graphic expression	ST expression
Dispart8Bit	Byte Data Separation	FUN		Dispart8Bit(In, Num, AryOut);

Variables

Name	Meaning	I/O	Description	Valid range	Unit	Default
In	Data to separate	Input	Bit string to separate	Depends on data type.	---	*
Num	Number of bytes to separate		Number of bytes to separate	0 to No. of bytes in <i>In</i>		1
AryOut[] (array)	Separation results array	In-out	Separation results array	Depends on data type.	---	---
Out	Return value	Output	Always TRUE	TRUE only	---	---

* If you omit the input parameter, the default value is not applied. A building error will occur.

	Boolean	Bit strings				Integers							Real numbers	Times, durations, dates, and text strings						
	BOOL	BYTE	WORD	DWORD	LWORD	USINT	UINT	UDINT	ULINT	SINT	INT	DINT	LINT	REAL	LREAL	TIME	DATE	TOD	DT	STRING
In		OK	OK	OK	OK															
Num						OK														
AryOut[] (array)		OK																		
Out	OK																			

Function

The Dispart8Bit instruction separates data to separate *In* into individual bytes and stores them in separation results array *AryOut[]*.

First, *In* is separated into bytes. Then, the lowest byte is stored in *AryOut[0]*. Then, the next byte is stored in *AryOut[1]*. This process is repeated for the number of bytes that is specified in number of bytes to separate *Num*.

The following example is for when *Num* is USINT#3.

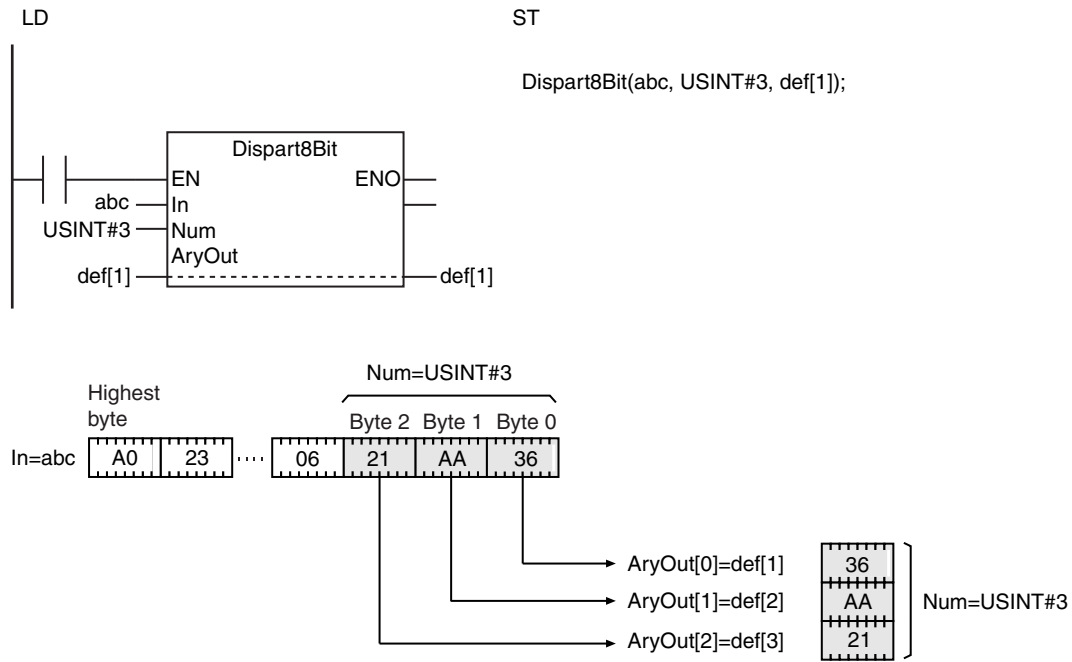

Additional Information

Use the Unite8Bit_** instruction (page 2-473) to join 1-byte units from array elements.

Precautions for Correct Use

- Return value *Out* is not used when the instruction is used in ST.
- An error occurs in the following cases. *ENO* will be FALSE, and *AryOut[]* will not change.
 - The value of *Num* is outside of the valid range.
 - The value of *Num* exceeds the number of bytes in *In*.

Unite8Bit_**

The Unite8Bit_** instructions join bytes of data into a bit string.

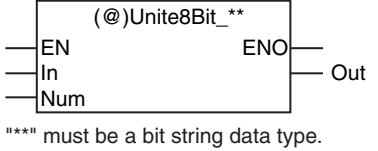
Instruction	Name	FB/FUN	Graphic expression	ST expression
Unite8Bit_**	Byte Data Join Group	FUN		Out:=Unite8Bit_**(In, Num); "*** must be a bit string data type.

Variables

Name	Meaning	I/O	Description	Valid range	Unit	Default
In[] (array)	Array to join	Input	Array to join	Depends on data type.	---	*
Num	Number of bytes to join		Number of bytes to join	0 to No. of bytes in <i>Out</i>		1
Out	Joined result	Output	Bit string with joined result	Depends on data type.	---	---

* If you omit the input parameter, the default value is not applied. A building error will occur.

	Boolean	Bit strings					Integers							Real numbers	Times, durations, dates, and text strings					
	BOOL	BYTE	WORD	DWORD	LWORD	USINT	UINT	UDINT	ULINT	SINT	INT	DINT	LINT	REAL	LREAL	TIME	DATE	TOD	DT	STRING
In[] (array)		OK																		
Num						OK														
Out		OK	OK	OK	OK															

Function

The Unite8Bit_** instructions join elements of array to join *In[]* to create a bit string in joined result *Out*. Number of bytes to join *Num* specifies the number of array elements to join. First, *In[0]* to *In[Num-1]* are joined to create a bit string with *Num* bytes. To this, 16#00 is added to the upper bytes for the number of bytes of *Out* minus the value of *Num*. The result is stored in *Out*.

The name of the instruction is determined by the data type of *Out*. For example, if *Out* is the DWORD data type, the instruction is Unite8Bit_DWORD.

The following example shows the Unite8Bit_DWORD instruction when *Num* is USINT#3.

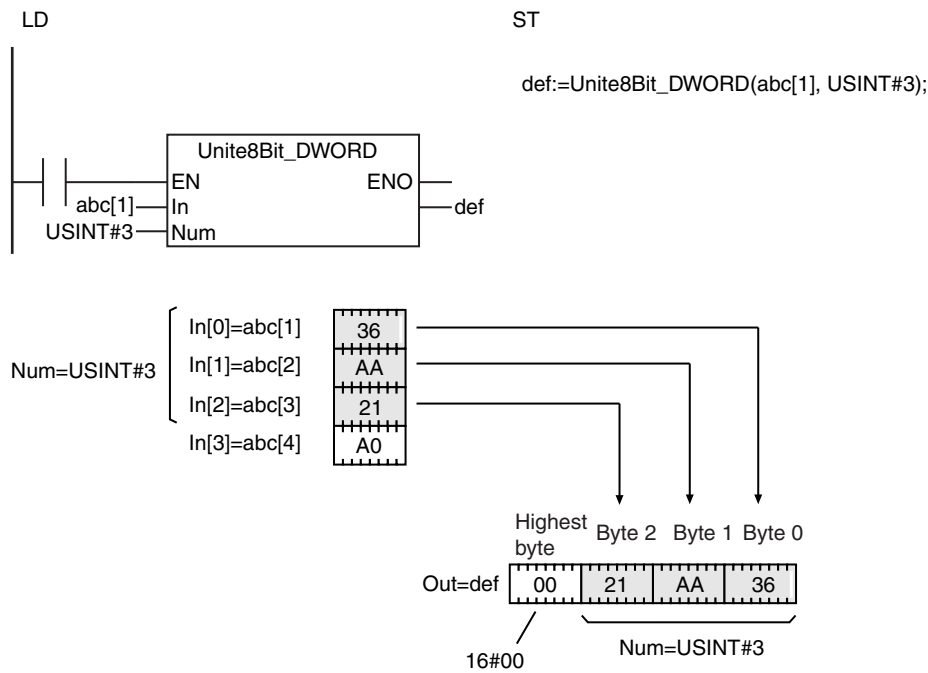

Additional Information

Use the Dispart8Bit instruction (page 2-471) to separate a bit string into 1-byte units.

Precautions for Correct Use

- If the value of *Num* is 0, the value of *Out* is 0.
- An error occurs in the following cases. *ENO* will be FALSE, and *Out* will not change.
 - The value of *Num* is outside of the valid range.
 - The value of *Num* exceeds the array area of *In[]*.

ToAryByte

The ToAryByte instruction separates a variable into bytes and stores the bytes in a BYTE array.

Instruction	Name	FB/FUN	Graphic expression	ST expression
ToAryByte	Conversion to Byte Array	FUN	<pre> graph LR subgraph ToAryByte EN[EN] In[In] Order[Order] AryOut[AryOut] end Out[Out] EN --- Out In --- Out Order --- Out AryOut --- Out </pre>	Out:=ToAryByte(In, Order, AryOut);

Variables

Name	Meaning	I/O	Description	Valid range	Unit	Default
In	Data to convert	Input	Data to convert	Depends on data type.	---	*
Order	Conversion order		Conversion order	_LOW_HIGH or _HIGH_LOW		_LOW_HIGH
AryOut[] (array)	Conversion results array	In-out	Conversion results array	Depends on data type.	---	---
Out	Number of elements in result	Output	Number of elements in result	Depends on data type.	---	---

* If you omit the input parameter, the default value is not applied. A building error will occur.

	Boolean	Bit strings				Integers							Real numbers	Times, durations, dates, and text strings						
	BOOL	BYTE	WORD	DWORD	LWORD	USINT	UINT	UDINT	ULINT	SINT	INT	DINT	LINT	REAL	LREAL	TIME	DATE	TOD	DT	STRING
In	OK	OK	OK	OK	OK	OK	OK	OK	OK	OK	OK	OK	OK	OK	OK	OK	OK	OK	OK	OK
	An enumeration, array, array element, structure, or structure member can also be specified.																			
Order	Refer to <i>Function</i> for the enumerators for the enumerated type _eBYTE_ORDER.																			
AryOut[] (array)		OK																		
Out							OK													

Function

The ToAryByte instruction separates the value of data to convert *In* into individual bytes and stores them in order in conversion results array *AryOut[]* starting from *AryOut[0]*. Number of elements in result *Out* contains the number of elements stored in *AryOut[]*.

Conversion order *Order* specifies the order in which to convert the value of *In* to bytes. The data type of *Order* is enumerated type _eBYTE_ORDER. The meaning of the enumerators are as follows:

Enumerator	Meaning
_LOW_HIGH	Lower byte first, higher byte last
_HIGH_LOW	Higher byte first, lower byte last

When the Data Type of *In* Is Two Bytes or Larger

If the data type of *In* is two bytes or larger, *In* is separated into bytes and stored in *AryOut*[*i*]. The following data types have two bytes or more.

Classification	Data type
Bit strings	WORD, DWORD, and LWORD
Integers	UINT, UDINT, ULINT, INT, DINT, and LINT
Real numbers	REAL and LREAL
Times, durations, dates, and text strings	TIME, DATE, TOD, DT, and STRING types of two bytes or more
Others	An enumeration, an array for which the total for all elements is 2 bytes or more, an array element that is 2 bytes or more, a structure for which the total for all members is 2 bytes or more, or a structure member that is 2 bytes or more

The processing procedure is as follows:

- 1** First, the value in *In* is separated into words (two bytes).
- 2** The lowest word is separated into bytes.
- 3** If *Order* is *_LOW_HIGH*, the lower byte is stored in *AryOut*[0] and the higher byte is stored in *AryOut*[1]. If *Order* is *_HIGH_LOW*, the higher byte is stored in *AryOut*[0] and the lower byte is stored in *AryOut*[1].
- 4** The next word is separated into bytes and stored in *AryOut*[2] and *AryOut*[3] in the same way.
- 5** This process is repeated to the end of the value of *In*. If *In* is an array, the same process is repeated to the last element in *In*.

The following example is for when *In* is a DWORD array with three elements and *Order* is *_LOW_HIGH*.

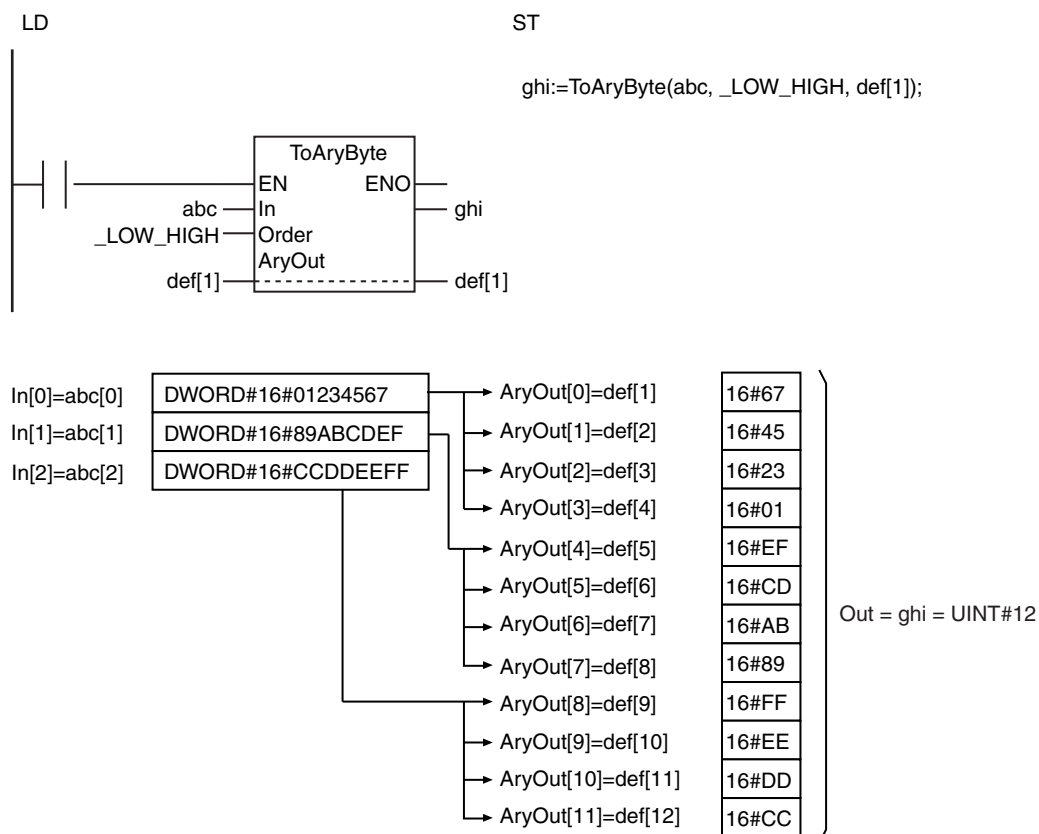

The following example is for when *In* is the same as above and *Order* is *_HIGH_LOW*.

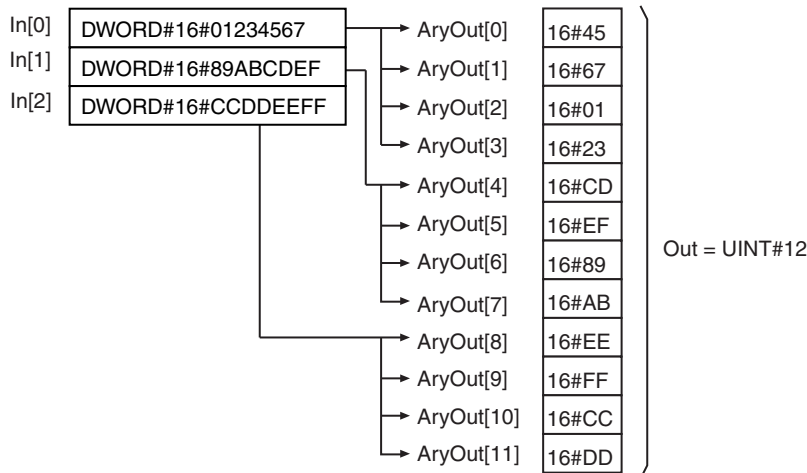

When the Data Type of *In* Is One Byte

If the data type of *In* is one byte, *In* is stored in *AryOut[i]* as one byte. The following data types have one byte.

Classification	Data type
Bit strings	BYTE
Integers	USINT and SINT
Real numbers	None
Times, durations, dates, and text strings	STRING types with one byte
Others	An array for which the total for all elements is 1 byte, an array element that is 1 byte, a structure for which the total for all members is 1 byte, or a structure member that is 1 byte.

The following storage method is used.

Value of <i>Order</i>	<i>In</i> (array or not)	Storage method in <i>AryOut[i]</i>
_LOW_HIGH	Not an array	Value of <i>In</i> is stored in <i>AryOut[0]</i> .
	Array	Value of <i>In[i]</i> is stored in <i>AryOut[i]</i> .
_HIGH_LOW	Not an array	Value of <i>In</i> is stored in <i>AryOut[1]</i> . 16#00 is stored in <i>AryOut[0]</i> .
	Array	<i>In[i]</i> (where <i>i</i> is even) is stored in <i>AryOut[i+1]</i> . <i>In[i]</i> (where <i>i</i> is odd) is stored in <i>AryOut[i-1]</i> . If the number of elements in <i>In[i]</i> is odd, 16#00 is stored last in <i>AryOut[n-1]</i> .

The following example is for when *In* is a SINT array with three elements and *Order* is *_LOW_HIGH*.

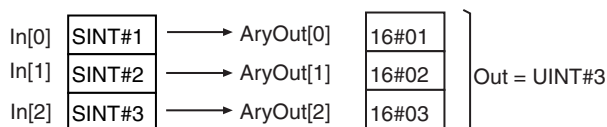

The following example is for when *In* is the same as above and *Order* is *_HIGH_LOW*.

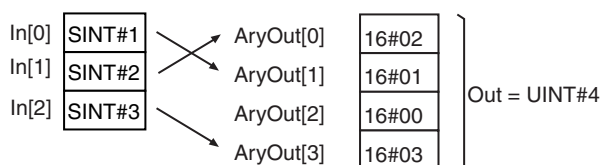

When *In* Is BOOL Data

If the data type of *In* is BOOL (one bit), data is stored in *AryOut[]* as described below.

Value of Order	<i>In</i> (array or not)	Storage method in <i>AryOut[]</i>
_LOW_HIGH	Not an array	The logical OR of the value of <i>In</i> and 16#00 is stored in <i>AryOut[0]</i> .
	Array	Values of <i>In[0]</i> to <i>In[7]</i> are joined and stored in <i>AryOut[0]</i> . Values of <i>In[8]</i> to <i>In[15]</i> are joined and stored in <i>AryOut[1]</i> . The same process is repeated to store the rest of the data. If there is not sufficient data in <i>In[]</i> for 8 values, FALSE is added to the most-significant bit. The value of <i>Out</i> is always even. If there are not sufficient bit values, the remaining values will all be FALSE.
_HIGH_LOW	Not an array	The logical OR of the value of <i>In</i> and 16#00 is stored in <i>AryOut[1]</i> . 16#00 is stored in <i>AryOut[0]</i>
	Array	Values of <i>In[0]</i> to <i>In[7]</i> are joined and stored in <i>AryOut[1]</i> . Values of <i>In[8]</i> to <i>In[15]</i> are joined and stored in <i>AryOut[0]</i> . The same process is repeated to store the rest of the data. The value of <i>Out</i> is always even. If there are not sufficient bit values, the remaining values will all be FALSE.

The following example is for when *In* is a BOOL array with 21 elements and *Order* is *_LOW_HIGH*.

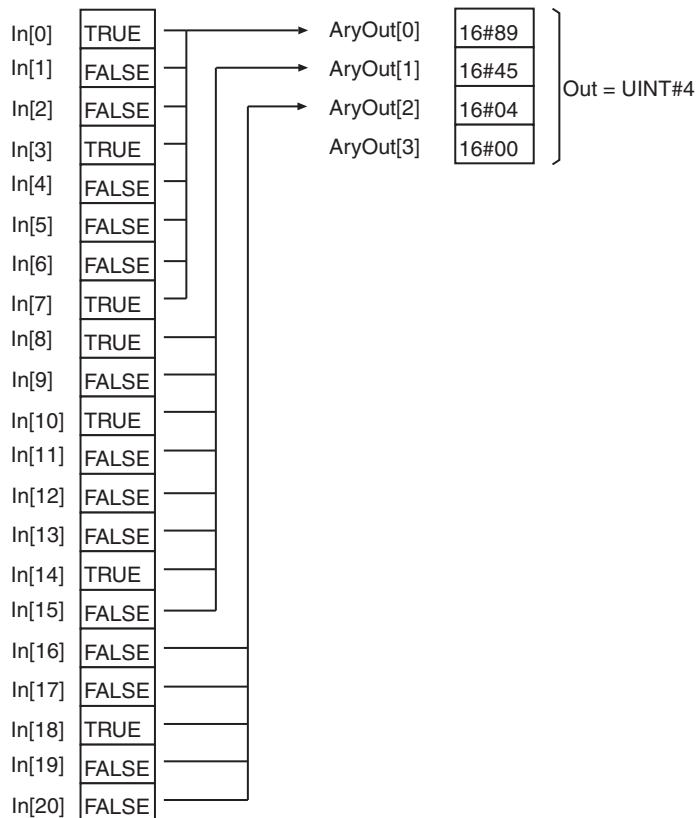

The following example is for when *In* is the same as above and *Order* is *_HIGH_LOW*.

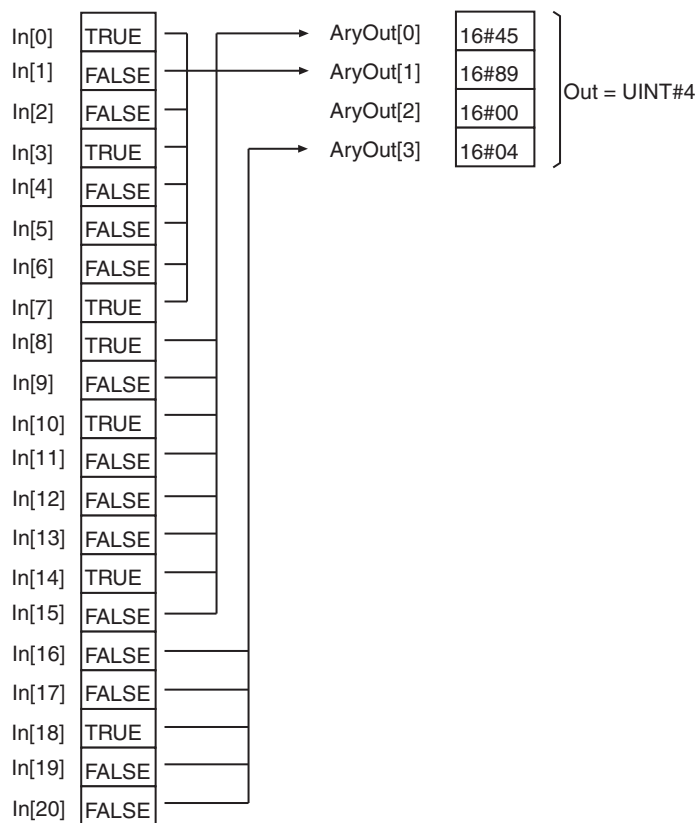

Precautions for Correct Use

- Always use a variable for the input parameter to pass to *In*. A building error will occur if a constant is passed.
- If *In* is an enumeration, you cannot directly pass an enumerator to it. A building error will occur if an enumerator is passed to it directly.
- If *In* is STRING data, the text string is not converted to numbers. The contents of the variable is taken as a bit string and converted to a byte array.
- If *In* is a structure, adjustment areas between members may be inserted into *AryOut*[].
- If the value of *Order* is *_HIGH_LOW* and the total number of bytes in *In* is an odd number, 16#00 is added to the end of *In* to make an even number of bytes before the conversion is started.
- An error occurs in the following cases. *ENO* will be FALSE, and *Out* and *AryOut*[*i*] will not change.
 - The value of *Order* is outside of the valid range.
 - The conversion result exceeds the array area of *AryOut*[*i*].

AryByteTo

The AryByteTo instruction joins BYTE array elements and stores the result in a variable.

Instruction	Name	FB/FUN	Graphic expression	ST expression
AryByteTo	Conversion from Byte Array	FUN	<pre> graph LR EN --- ENO In --- In Size --- Size Order --- Order OutVal --- OutVal subgraph AryByteTo In --- Size --- Order --- OutVal end OutVal --- Out </pre>	AryByteTo(In, Size, Order, OutVal);

Variables

Name	Meaning	I/O	Description	Valid range	Unit	Default
In[] (array)	Array to convert	Input	Array to convert	Depends on data type.	---	*
Size	Number of elements to convert		Number of elements in <i>In[]</i> to convert			1
Order	Conversion order		Conversion order			_LOW_HIGH or _HIGH_LOW
OutVal	Conversion result	In-out	Conversion result	Depends on data type.	---	---
Out	Return value	Output	Always TRUE	TRUE only	---	---

* If you omit the input parameter, the default value is not applied. A building error will occur.

	Boolean	Bit strings					Integers							Real numbers		Times, durations, dates, and text strings				
	BOOL	BYTE	WORD	DWORD	LWORD	USINT	UINT	UDINT	ULINT	SINT	INT	DINT	LINT	REAL	LREAL	TIME	DATE	TOD	DT	STRING
In[] (array)		OK																		
Size							OK													
Order	Refer to <i>Function</i> for the enumerators for the enumerated type <code>_eBYTE_ORDER</code> .																			
OutVal	OK	OK	OK	OK	OK	OK	OK	OK	OK	OK	OK	OK	OK	OK	OK	OK	OK	OK	OK	OK
	An enumeration, array, array element, structure, or structure member can also be specified.																			
Out	OK																			

Function

The AryByteTo instruction takes the first *Size* elements in array to convert *In[]* and joins them to match the size of the data type of conversion result *OutVal*. It then stores the result in *OutVal*.

Order specifies the order to join the elements of *In[]*. The data type of *Order* is enumerated type *_eBYTE_ORDER*. The meaning of the enumerators are as follows:

Enumerators	Meaning
<i>_LOW_HIGH</i>	Lower byte first, higher byte last
<i>_HIGH_LOW</i>	Higher byte first, lower byte last

When the Data Type of *OutVal* Is Two Bytes or Larger

If the data type of *OutVal* is two bytes or larger, elements from *In[]* are joined so that the result is just large enough for the size of the data type of *OutVal*. The result is stored in *OutVal*. The following data types have two bytes or more.

Classification	Data type
Bit strings	WORD, DWORD, and LWORD
Integers	UINT, UDINT, ULINT, INT, DINT, and LINT
Real numbers	REAL and LREAL
Times, durations, dates, and text strings	TIME, DATE, TOD, DT, and STRING types of two bytes or more
Others	An enumeration, an array for which the total for all elements is 2 bytes or more, an array element that is 2 bytes or more, a structure for which the total for all members is 2 bytes or more, or a structure member that is 2 bytes or more

The processing procedure is as follows:

- 1** *In[0]* and *In[1]* are joined according to the value of *Order* to create one word (two bytes) of data. If *Order* is *_LOW_HIGH*, the higher byte is stored in *In[1]* and the lower byte is stored in *In[0]*. If *Order* is *_HIGH_LOW*, the higher byte is stored in *In[0]* and the lower byte is stored in *In[1]*.
- 2** In the same way elements that start from *In[2]* and *In[3]* are joined to make more words of data.
- 3** The words of data are joined to match the size of the data type of *OutVal*. For example, if *OutVal* is DWORD data, four individual words of data are joined.
- 4** The resulting data is stored in *OutVal*.

The following example is for when *OutVal* is DWORD data, *Size* is *UINT#4*, and *Order* is *_LOW_HIGH*.

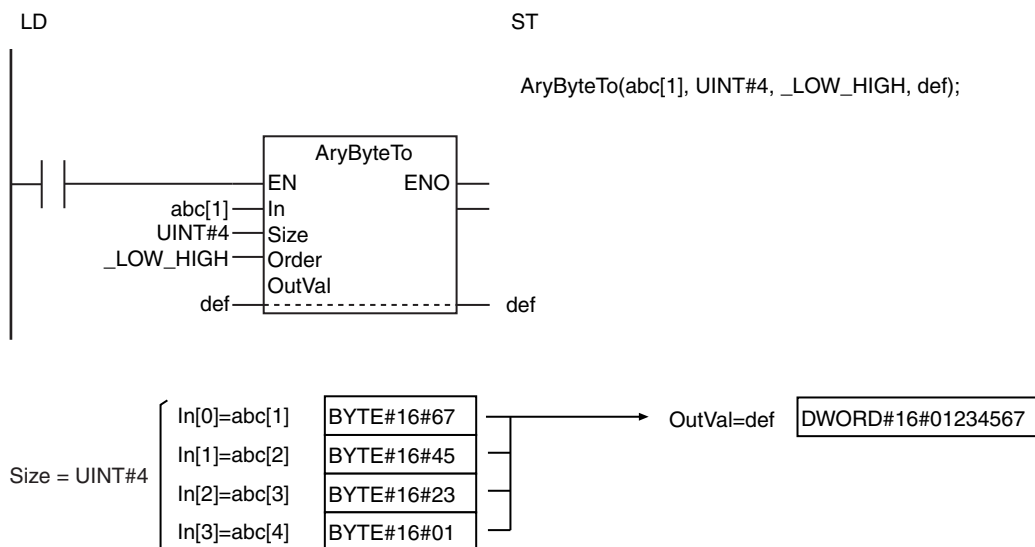

The following example is for when *OutVal* is the same as above, *Size* is *UINT#4*, and *Order* is *_HIGH_LOW*.

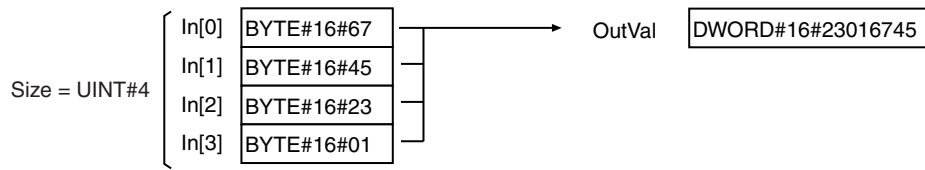

When the Data Type of *OutVal* Is One Byte

If the data type of *OutVal* is one byte, one byte of *In[]* is stored directly in *OutVal*.

The following data types have one byte.

Classification	Data type
Bit strings	BYTE
Integers	USINT and SINT
Real numbers	None
Times, durations, dates, and text strings	STRING types with one byte
Others	An array for which the total for all elements is 1 byte, an array element that is 1 byte, a structure for which the total for all members is 1 byte, or a structure member that is 1 byte.

The following storage method is used.

Value of <i>Order</i>	<i>OutVal</i> (array or not)	Storage method in <i>OutVal</i>
<i>_LOW_HIGH</i>	Not an array	Value of <i>In[0]</i> is stored in <i>OutVal</i>
	Array	Value of <i>In[i]</i> is stored in <i>OutVal[i]</i>
<i>_HIGH_LOW</i>	Not an array	Value of <i>In[1]</i> is stored in <i>OutVal</i>
	Array	<i>In[i]</i> (where <i>i</i> is even) is stored in <i>OutVal[i+1]</i> . <i>In[i]</i> (where <i>i</i> is odd) is stored in <i>OutVal[i-1]</i> . If the value of <i>Size</i> is odd, data is stored up to <i>OutVal[Size]</i> and 16#00 is stored in <i>OutVal[Size-1]</i> .

The following example is for when *OutVal* is a SINT array with three elements, *Size* is *UINT#3*, and *Order* is *_LOW_HIGH*.

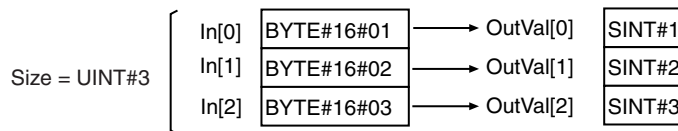

The following example is for when *OutVal* and *Size* are the same as above and *Order* is *_HIGH_LOW*.

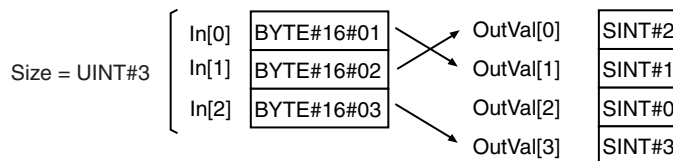

When *OutVal* Is BOOL Data

If the data type of *OutVal* is BOOL (one bit), data is stored in *OutVal* as described below.

Value of Order	<i>OutVal</i> (array or not)	Storage method in <i>OutVal</i>
_LOW_HIGH	Not an array	Value of bit 0 of <i>In[0]</i> is stored in <i>OutVal</i> .
	Array	Value of <i>In[0]</i> is separated and stored in <i>OutVal[0]</i> to <i>OutVal[7]</i> . Value of <i>In[1]</i> is separated and stored in <i>OutVal[8]</i> to <i>OutVal[15]</i> . The same process is repeated to store the rest of the data. Remaining bits are discarded.
_HIGH_LOW	Not an array	Value of bit 0 of <i>In[1]</i> is stored in <i>OutVal</i> .
	Array	Value of <i>In[0]</i> is separated and stored in <i>OutVal[8]</i> to <i>OutVal[15]</i> . Value of <i>In[1]</i> is separated and stored in <i>OutVal[0]</i> to <i>OutVal[7]</i> . The same process is repeated to store the rest of the data. Remaining bits are discarded.

The following example is for when *OutVal* is a BOOL array with 21 elements, *Size* is UINT#3, and *Order* is *_LOW_HIGH*.

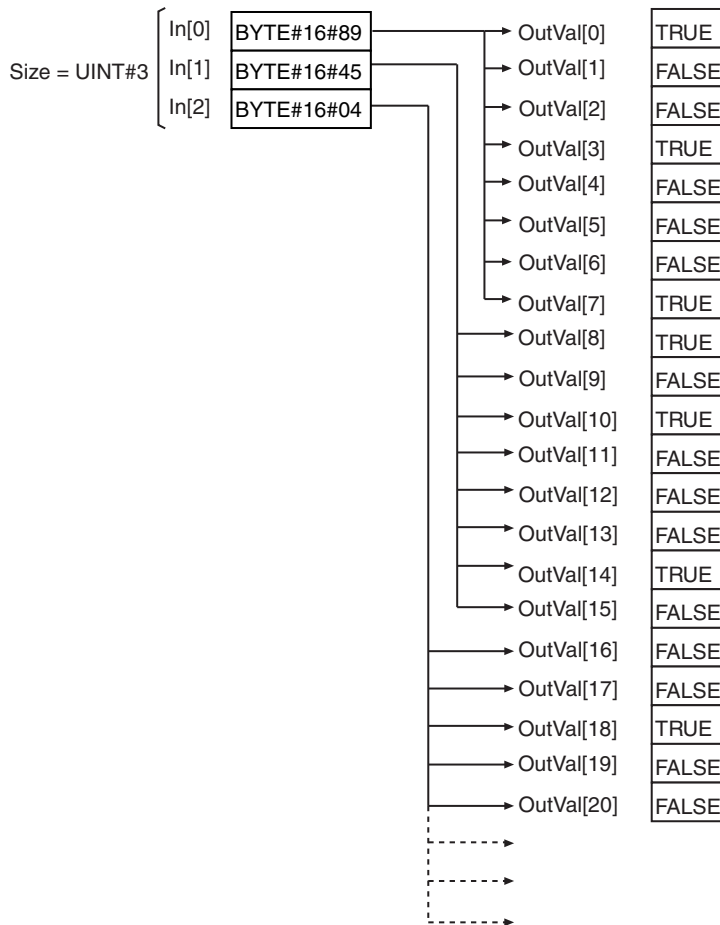

The following example is for when *OutVal* and *Size* are the same as above and *Order* is *_HIGH_LOW*.

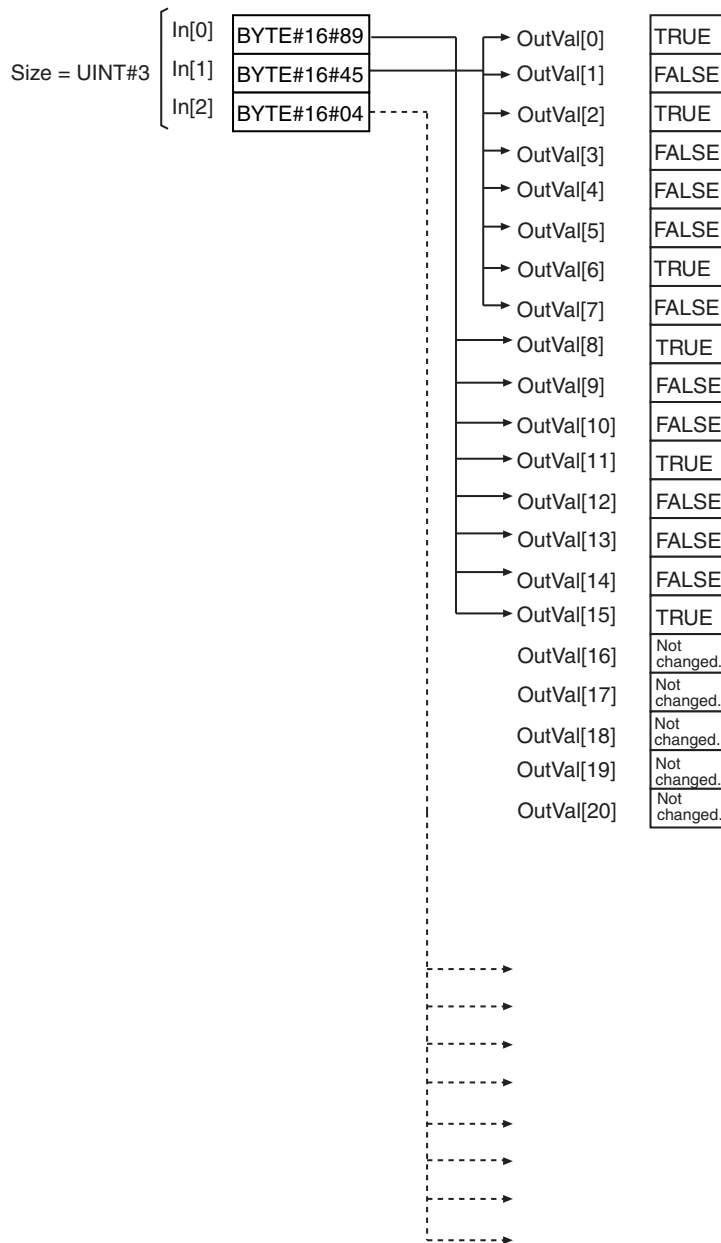

Precautions for Correct Use

- If *OutVal* is a structure, some of the values of *In[]* may be inserted in adjustment areas between members depending on the composition.
- If the value of *Size* is 0, the value of *Out* will be TRUE and *OutVal* will not change.
- Return value *Out* is not used when the instruction is used in ST.
- An error occurs in the following cases. *ENO* will be FALSE, and *OutVal* will not change.
 - The value of *Order* is outside of the valid range.
 - The value of *Size* exceeds the number of elements in *In[]*.

SizeOfAry

The SizeOfAry instruction gets the number of elements in an array.

Instruction	Name	FB/FUN	Graphic expression	ST expression
SizeOfAry	Get Number of Array Elements	FUN		Out:=SizeOfAry(In);

Variables

Name	Meaning	I/O	Description	Valid range	Unit	Default
In[] (array)	Array	Input	Array	Depends on data type.	---	*
Out	Number of elements	Output	Number of elements	Depends on data type.	---	---

* If you omit the input parameter, the default value is not applied. A building error will occur.

	Boolean	Bit strings				Integers							Real numbers	Times, durations, dates, and text strings						
	BOOL	BYTE	WORD	DWORD	LWORD	USINT	UINT	UDINT	ULINT	SINT	INT	DINT	LINT	REAL	LREAL	TIME	DATE	TOD	DT	STRING
In[] (array)	OK	OK	OK	OK	OK	OK	OK	OK	OK	OK	OK	OK	OK	OK	OK	OK	OK	OK	OK	OK
Out						OK														

Arrays of enumerations or structures can also be specified.

Function

The SizeOfAry instruction gets the number of elements in array *In[]*. For the input parameter, use an array name, such as *array*, and not an array element name, such as *array[0]*.

The following figure shows a programming example.

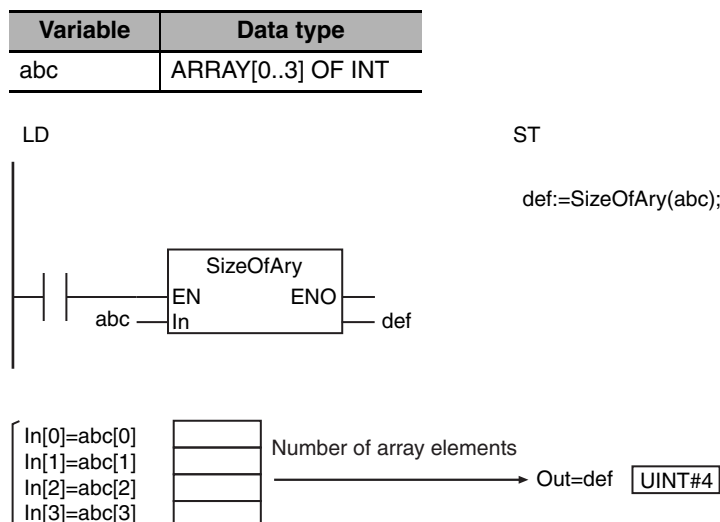

Additional Information

In[] can be an array with two or more dimensions. *Out* will contain the total number of elements for all dimensions of *In[]*. For example, if the input parameter that is passed to *In[]* is *ARRAY[0..1,0..2]*, the value of *Out* will be *UINT#6*.

Variable	Data type
abc	ARRAY[0..1,0..2] OF BOOL

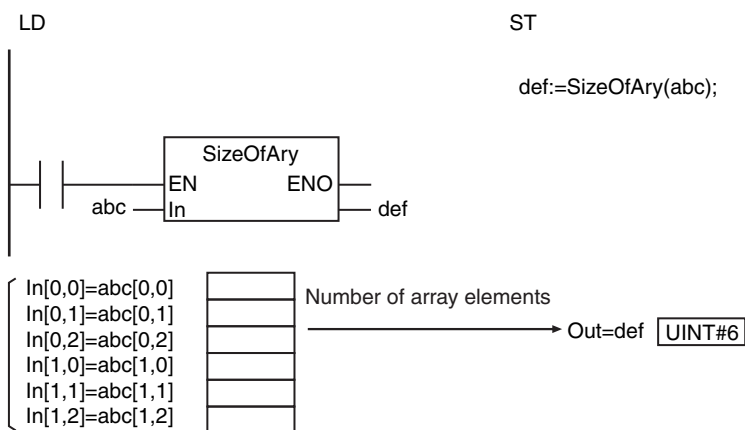

PackWord

The PackWord instruction joins two 1-byte data into a 2-byte data.

Instruction	Name	FB/ FUN	Graphic expression	ST expression
PackWord	2-byte Join	FUN		Out:=PackWord(High,Low);

Version Information

A CPU Unit with unit version 1.12 or later and Sysmac Studio version 1.16 or higher are required to use this instruction.

Variables

Name	Meaning	I/O	Description	Valid range	Unit	Default
High	Byte data H	Input	Data in bytes stored in bit 15-8	Depends on data type.	---	0
Low	Byte data L		Data in bytes stored in bit 7-0	Depends on data type.	---	0
Out	Joined data	Output	2-byte data	Depends on data type.	---	---

	Boolean	Bit strings				Integers							Real numbers		Times, durations, dates, and text strings					
	BOOL	BYTE	WORD	DWORD	LWORD	USINT	UINT	UDINT	ULINT	SINT	INT	DINT	LINT	REAL	LREAL	TIME	DATE	TOD	DT	STRING
High		OK																		
Low		OK																		
Out			OK																	

Function

The PackWord instruction joins two 1-byte data into a 2-byte data.

The data specified in *High* is stored in bit 15-8, and the data specified in *Low* is stored in bit 7-0.

The following example shows the instruction when *High* is 16#12 and *Low* is 16#34.

The value of variable *abc* will be 16#1234.

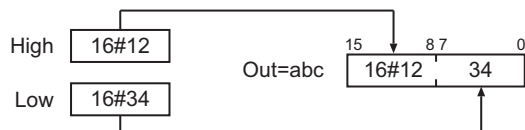

● LD

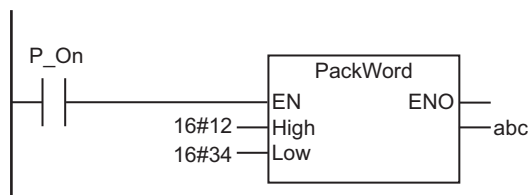

● ST

`abc:=PackWord(16#12,16#34);`

PackDword

The PackDword instruction joins four 1-byte data into a 4-byte data.

Instruction	Name	FB/ FUN	Graphic expression	ST expression
PackDword	4-byte Join	FUN		<pre>Out:=PackDword(HighHigh, HighLow, LowHigh, LowLow);</pre>

Version Information

A CPU Unit with unit version 1.12 or later and Sysmac Studio version 1.16 or higher are required to use this instruction.

Variables

Name	Meaning	I/O	Description	Valid range	Unit	Default
HighHigh	Byte data HH	Input	Data in bytes stored in bit 31-24	Depends on data type.	---	0
HighLow	Byte data HL		Data in bytes stored in bit 23-16	Depends on data type.	---	0
LowHigh	Byte data LH		Data in bytes stored in bit 15-8	Depends on data type.	---	0
LowLow	Byte data LL		Data in bytes stored in bit 7-0	Depends on data type.	---	0
Out	Joined data	Output	4-byte data	Depends on data type.	---	---

	Boolean	Bit strings					Integers							Real numbers	Times, durations, dates, and text strings					
	BOOL	BYTE	WORD	DWORD	LWORD	USINT	UINT	UDINT	ULINT	SINT	INT	DINT	LINT	REAL	LREAL	TIME	DATE	TOD	DT	STRING
HighHigh		OK																		
HighLow		OK																		
LowHigh		OK																		
LowLow		OK																		
Out				OK																

Function

The PackDword instruction joins four 1-byte data into a 4-byte data.

The data specified in *HighHigh* is stored in bit 31-24, the data specified in *HighLow* in bit 23-16, the data specified in *LowHigh* in bit 15-8, and the data specified in *LowLow* in bit 7-0.

The following example shows the instruction when *HighHigh* is 16#12, *HighLow* is 16#34, *LowHigh* is 16#56, and *LowLow* is 16#78.

The value of variable *abc* will be 16#12345678.

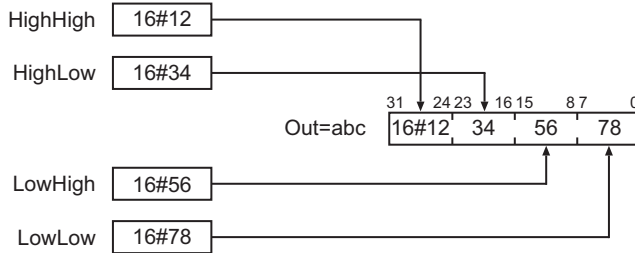

● LD

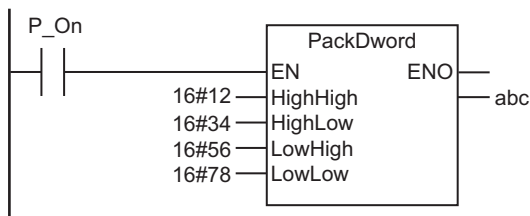

● ST

```
abc:=PackDword(16#12,16#34,16#56,16#78);
```

Stack and Table Instructions

Instruction	Name	Page
StackPush	Push onto Stack	2-492
StackFIFO and StackLIFO	First In First Out/Last In First Out	2-501
StackIns	Insert into Stack	2-504
StackDel	Delete from Stack	2-506
RecSearch	Record Search	2-508
RecRangeSearch	Range Record Search	2-513
RecSort	Record Sort	2-518
RecNum	Get Number of Records	2-524
RecMax and RecMin	Maximum Record Search/ Minimum Record Search	2-526

StackPush

The StackPush instruction stores a value at the top of a stack.

Instruction	Name	FB/FUN	Graphic expression	ST expression
StackPush	Push onto Stack	FUN		StackPush(In, InOut, Size, Num);

Variables

Name	Meaning	I/O	Description	Valid range	Unit	Default
In	Input value	Input	Value, structure, or structure member to place in the stack	Depends on data type.	---	---
Size	Number of stack elements		Number of stack array elements			1
InOut[] (array)	Stack array	In-out	Array that functions as stack	Depends on data type.	---	---
Num	Number of stored elements		Number of elements stored in stack			---
Out	Return value	Output	Always TRUE	TRUE only	---	---

	Boolean	Bit strings					Integers							Real numbers	Times, durations, dates, and text strings					
	BOOL	BYTE	WORD	DWORD	LWORD	USINT	UINT	UDINT	ULINT	SINT	INT	DINT	LINT	REAL	LREAL	TIME	DATE	TOD	DT	STRING
In	OK	OK	OK	OK	OK	OK	OK	OK	OK	OK	OK	OK	OK	OK	OK	OK	OK	OK	OK	OK
	An enumeration, structure, or structure member can also be specified.																			
Size							OK													
InOut[] (array)	Must be an array with elements that have the same data type as <i>In</i> .																			
Num							OK													
Out	OK																			

Function

The instruction assumes that there are number of stored elements *Num* elements stored in stack array *InOut[]*. Input value *In* is written to the next element, *InOut[Num]*. Then, *Num* is incremented. For number of stack elements *Size*, specify the number of elements in *InOut[]* to use as a stack.

The following example is for when *Size* is UINT#5 and *Num* is UINT#2.

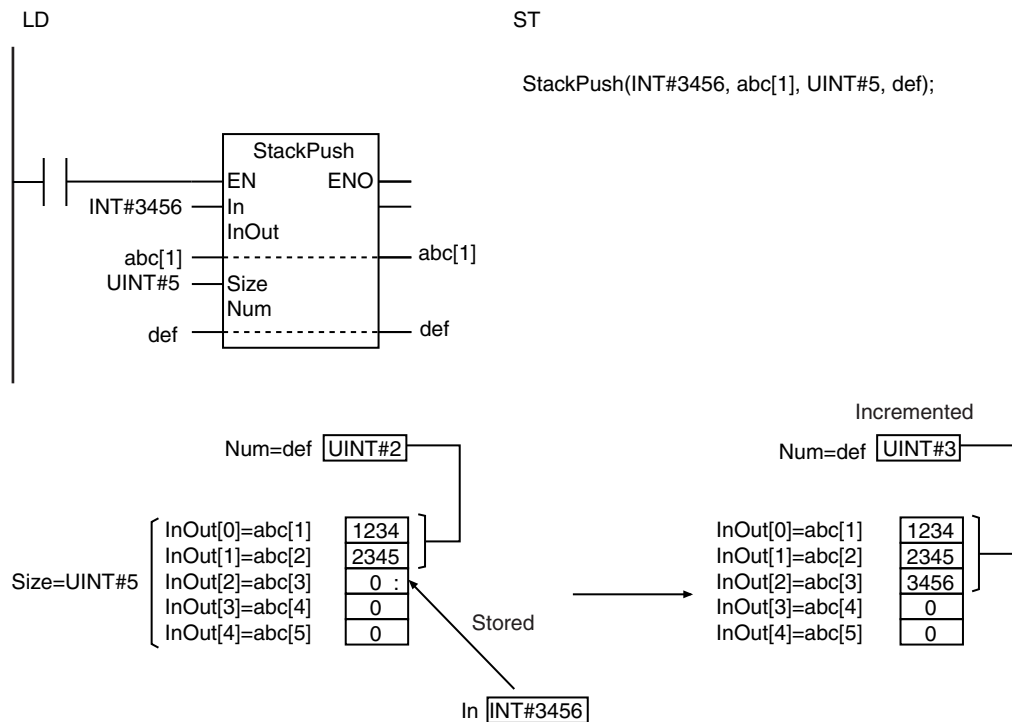

Additional Information

Use the StackFIFO or StackLIFO instruction (page 2-501) to remove the bottom or top value that was stored in the stack.

Precautions for Correct Use

- Use the same data type for *In* and the elements of *InOut[]*. If they are different, a building error will occur.
- When an element in the array is passed to *InOut[]*, all elements below the passed element are processed.
- The value of *InOut[]* or *Num* does not change if the value of *Size* is 0.
- Always use a variable for the input parameter to pass to *In*. A building error will occur if a constant is passed.
- If *In* is an enumeration, you cannot directly pass an enumerator to it. A building error will occur if an enumerator is passed to it directly.
- Return value *Out* is not used when the instruction is used in ST.
- An error occurs in the following cases. *ENO* will be FALSE, and *InOut[]* will not change.
 - The value of *Size* is not 0 and *Num* is greater than or equal to *Size*.
 - The value of *Size* exceeds the array area of *InOut[]*.
 - *In* and *InOut[]* are STRING data and the number of bytes in *In* exceeds the size of *InOut[]*.

Sample Programming

The array variable *StcA[0..9]* is used as a stack. As preparations, three values (UINT#1111, UINT#2222, and UINT#3333) are stored in the stack.

StcA[0]	1111
StcA[1]	2222
StcA[2]	3333
StcA[3]	0
StcA[4]	0
StcA[5]	0
StcA[6]	0
StcA[7]	0
StcA[8]	0
StcA[9]	0

The StackPush instruction is used to store a new value (UINT#4444) at the top of the stack *StcA[3]*. That means there will be four values in the stack.

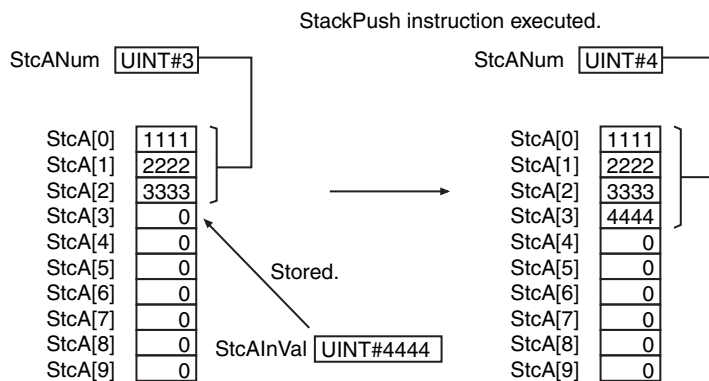

Then, the StackLIFO instruction is used to remove one value at the top of the stack *StcA[3]*. That means there will be three values in the stack.

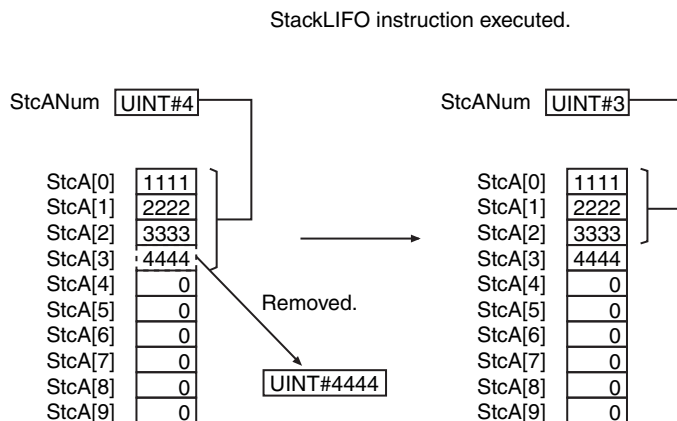

Finally, the StackIns instruction is used to insert a value (UINT#5555) between *StcA[1]* and *StcA[2]*. That means there will be four values in the stack.

StackIns instruction executed.

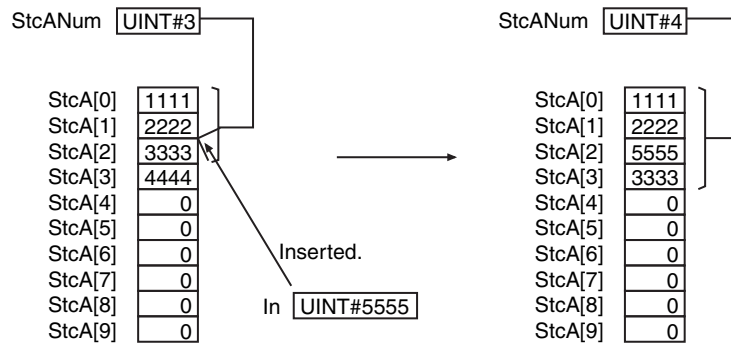

LD

Variable	Data type	Initial value	Comment
InitStc	BOOL	FALSE	Stack initialization condition
StcANum	UINT	0	Number of stored elements
StcA	ARRAY[0..9] OF UINT	[10(0)]	Stack array
StcASize	UINT	0	Number of stack elements
SetParaPush	BOOL	FALSE	Execution condition to set <i>StcAInVal</i> .
StcAInVal	UINT	0	Value added by StackPush
StcAPushStat	BOOL	FALSE	StackPush execution condition
StackPush_err	BOOL	FALSE	StackPush error flag
StcALIFOStat	BOOL	FALSE	StackLIFO execution condition
StcAOutVal	UINT	0	Value removed by StackLIFO
StackLIFO_err	BOOL	FALSE	StackLIFO error flag
SetParaIns	BOOL	FALSE	Execution condition to set <i>StcAInsVal</i> and <i>StcAOffset</i>
StcAInsVal	UINT	0	Value inserted by StackIns
StcAOffset	UINT	0	Offset for StackIns
StcAInsStat	BOOL	FALSE	StackIns execution condition
StackIns_err	BOOL	FALSE	StackIns error flag

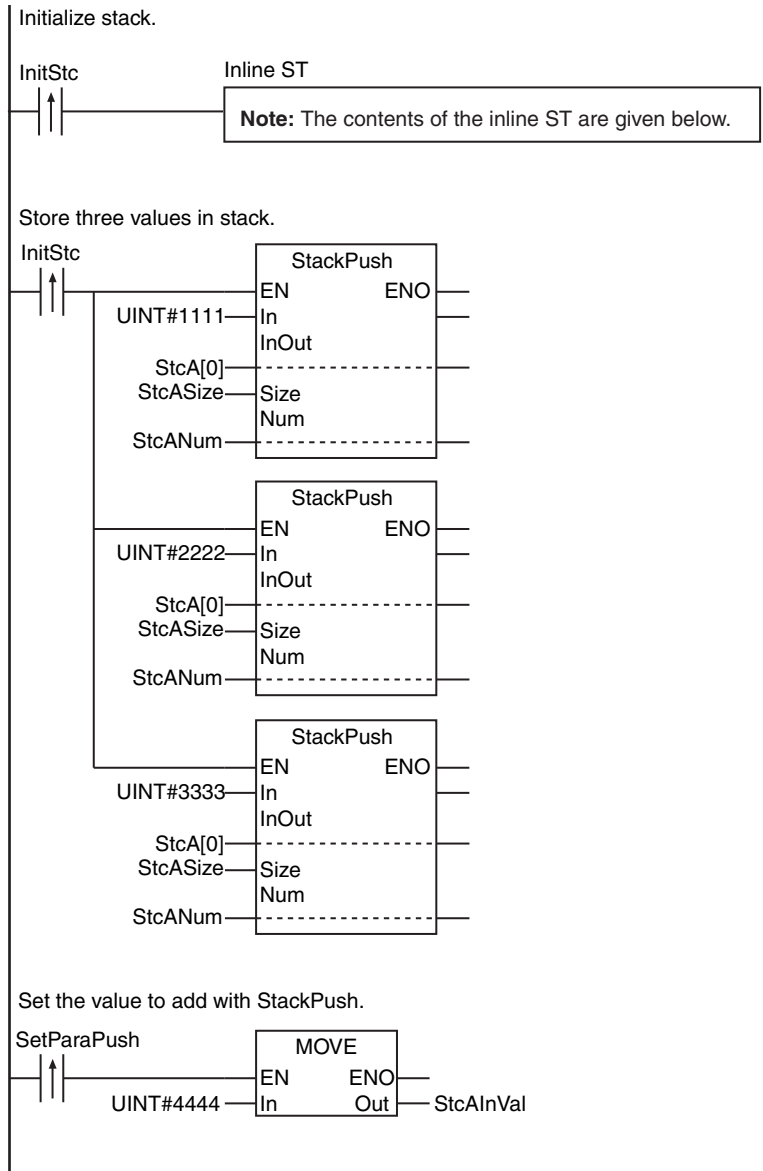

Add data with StackPush instruction.

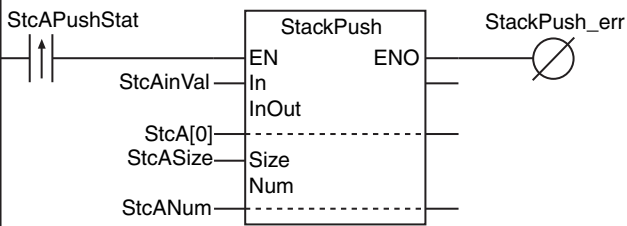

Processing after normal end of StackPush

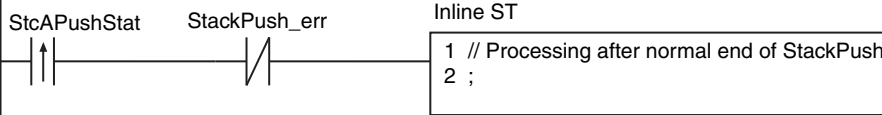

Processing after error end of StackPush

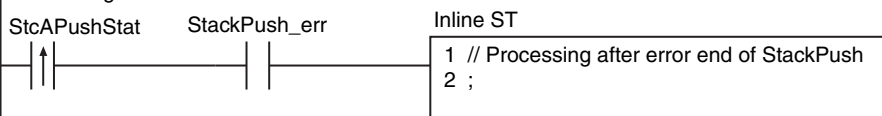

Remove data with StackLIFO instruction.

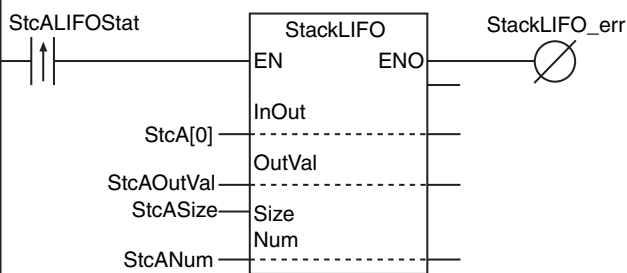

Processing after normal end of StackLIFO

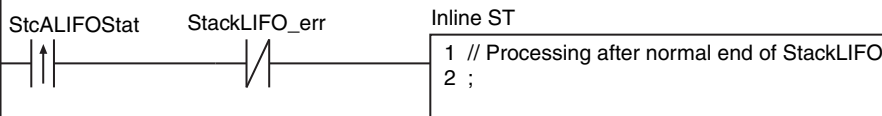

Processing after error end of StackLIFO

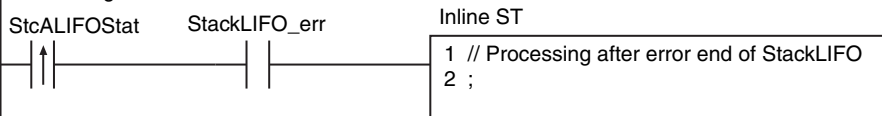

Set the insert value and offset with StackInsh.

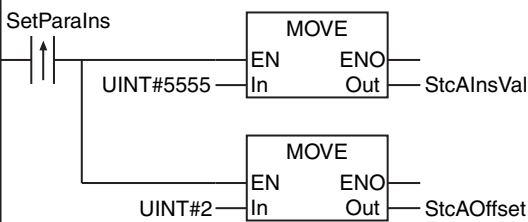

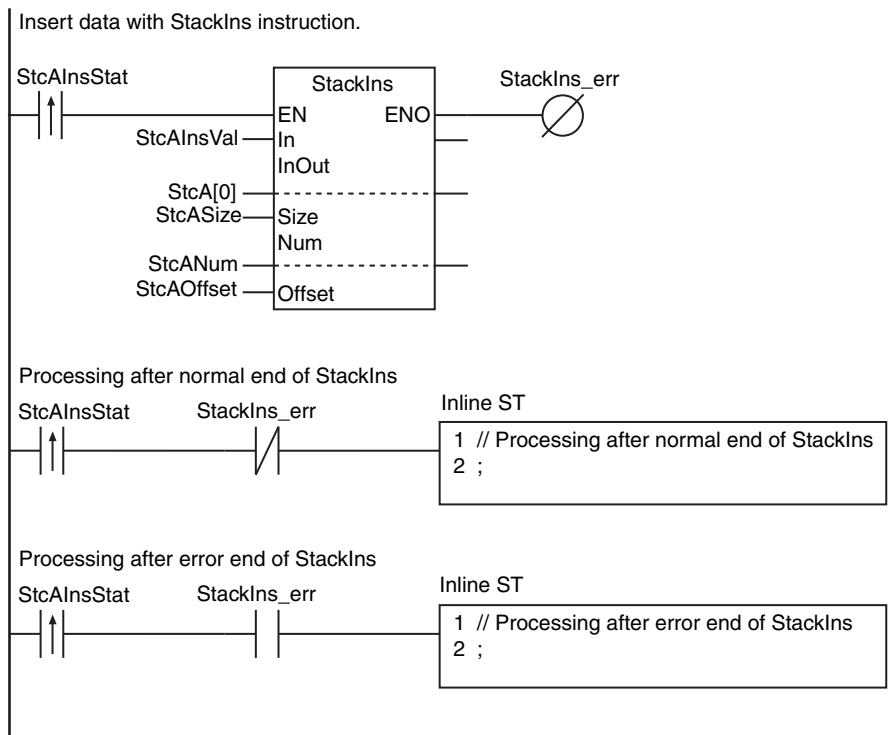

Contents of Inline ST

```
StcANUM:=0;
Clear(StcA);
StcASize:=SizeOfAry(StcA);
```

ST

Variable	Data type	Initial value	Comment
InitStc	BOOL	FALSE	Stack initialization condition
preInitStc	BOOL	FALSE	Value of <i>InitStc</i> from previous task period
StcANum	UINT	0	Number of stored elements
StcA	ARRAY[0..9] OF UINT	[10(0)]	Stack array
StcASize	UINT	0	Number of stack elements
StcAPushStat	BOOL	FALSE	StackPush execution condition
preStcAPushStat	BOOL	FALSE	Value of <i>StcAPushStat</i> from previous task period
StcAInVal	UINT	0	Value added by StackPush
StcAPush_OK	BOOL	FALSE	StackPush normal end flag
StcAPushNormalEnd	BOOL	FALSE	Processing after normal end of StackPush
StcAPushErrorEnd	BOOL	FALSE	Processing after error end of StackPush
StcALIFOStat	BOOL	FALSE	StackLIFO execution condition
preStcALIFOStat	BOOL	FALSE	Value of <i>StcALIFOStat</i> from previous task period
StcAOutVal	UINT	0	Value removed by StackLIFO
StcALIFO_OK	BOOL	FALSE	StackLIFO normal end flag
StcALIFONormalEnd	BOOL	FALSE	Processing after normal end of StackLIFO
StcALIFOErrorEnd	BOOL	FALSE	Processing after error end of StackLIFO
StcAInsStat	BOOL	FALSE	StackIns execution condition
preStcAInsStat	BOOL	FALSE	Value of <i>StcAInsStat</i> from previous task period
StcAInsVal	UINT	0	Value inserted by StackIns
StcAOffset	UINT	0	Offset for StackIns
StcAIns_OK	BOOL	FALSE	StackIns normal end flag
StcAInsNormalEnd	BOOL	FALSE	Processing after normal end of StackIns
StcAInsErrorEnd	BOOL	FALSE	Processing after error end of StackIns

```

// Initialize stack.
IF ( (InitStc=TRUE) AND (preInitStc=FALSE) ) THEN
    StcANum:=0;
    Clear(StcA);
    StcASize:=SizeOfAry(StcA);
END_IF;

// Store three values in stack.
IF ( (InitStc=TRUE) AND (preInitStc=FALSE) ) THEN
    StackPush(In:=UINT#1111, InOut:=StcA[0], Size:=StcASize, Num:=StcANum);
    StackPush(In:=UINT#2222, InOut:=StcA[0], Size:=StcASize, Num:=StcANum);
    StackPush(In:=UINT#3333, InOut:=StcA[0], Size:=StcASize, Num:=StcANum);
END_IF;

preInitStc:=InitStc;

// Add data with StackPush instruction.
IF ( (StcAPushStat=TRUE) AND (preStcAPushStat=FALSE) ) THEN
    StcAInVal:=UINT#4444;
    StackPush(
        In    :=StcAInVal,    // Value to add
        InOut :=StcA[0],     // First element in stack array
        Size  :=StcASize,     // Number of stack elements
        Num   :=StcANum,      // Number of stored elements
        ENO   =>StcAPush_OK); // Normal end flag

```

```

IF (StcAPush_OK=TRUE) THEN
    StcAPushNormalEnd:=TRUE; // Processing after normal end
ELSE
    StcAPushErrorEnd :=TRUE; // Processing after error end
END_IF;
END_IF;
preStcAPushStat:=StcAPushStat;

// Remove data with StackLIFO instruction.
IF ( (StcALIFOStat=TRUE) AND (preStcALIFOStat=FALSE) ) THEN
    StackLIFO(
        InOut :=StcA[0], // First element in stack array
        OutVal :=StcAOutVal, // Value removed from stack
        Size :=StcASize, // Number of stack elements
        Num :=StcANum, // Number of stored elements
        ENO =>StcALIFO_OK); // Normal end flag
    IF (StcALIFO_OK=TRUE) THEN
        StcALIFONormalEnd:=TRUE; // Processing after normal end
    ELSE
        StcALIFOErrorEnd:=TRUE; // Processing after error end
    END_IF;
END_IF;
preStcALIFOStat:=StcALIFOStat;

// Insert data with StackIns instruction.
IF ( (StcAInsStat=TRUE) AND (preStcAInsStat=FALSE) ) THEN
    StcAInsVal:=UINT#5555;
    StcAOffset:=UINT#2;
    StackIns(
        In :=StcAInsVal, // Value to insert into stack
        InOut :=StcA[0], // First element in stack array
        Size :=StcASize, // Number of stack elements
        Num :=StcANum, // Number of stored elements
        Offset:=StcAOffset, // Offset at which to insert value
        ENO =>StcAIns_OK); // Normal end flag
    IF (StcAIns_OK=TRUE) THEN
        StcAInsNormalEnd:=TRUE;// Processing after normal end
    ELSE
        StcAInsErrorEnd:=TRUE; // Processing after error end
    END_IF;
END_IF;
preStcAInsStat:=StcAInsStat;

```

StackFIFO and StackLIFO

StackFIFO: Removes the bottom value from a stack.

StackLIFO: Removes the top value from a stack.

Instruction	Name	FB/FUN	Graphic expression	ST expression
StackFIFO	First In First Out	FUN		StackFIFO(InOut, OutVal, Size, Num);
StackLIFO	Last In First Out	FUN		StackLIFO(InOut, OutVal, Size, Num);

Variables

Name	Meaning	I/O	Description	Valid range	Unit	Default
Size	Number of stack elements	Input	Number of stack array elements	Depends on data type.	---	1
InOut[] (array)	Stack array	In-out	Array that functions as stack	Depends on data type.	---	---
OutVal	Output value		Value or structure output from stack			
Num	Number of stored elements		Number of elements stored in stack			
Out	Return value	Output	Always TRUE	TRUE only	---	---

	Boolean	Bit strings					Integers							Real numbers		Times, durations, dates, and text strings				
	BOOL	BYTE	WORD	DWORD	LWORD	USINT	UINT	UDINT	ULINT	SINT	INT	DINT	LINT	REAL	LREAL	TIME	DATE	TOD	DT	STRING
Size							OK													
InOut[] (array)	OK	OK	OK	OK	OK	OK	OK	OK	OK	OK	OK	OK	OK	OK	OK	OK	OK	OK	OK	OK
OutVal	Must be the same data type as the elements of <i>InOut[]</i> .																			
Num							OK													
Out	OK																			

Function

The instruction assumes that there are number of stored elements *Num* elements stored in stack array *InOut[]*. The instruction removes a value from the stack and assigns it to output value *OutVal*. For number of stack elements *Size*, specify the number of elements in *InOut[]* to use as a stack.

● StackFIFO

The StackFIFO removes the bottom value from a stack. Value of *InOut[0]* is assigned to *OutVal*. Then, all *Num - 1* elements from *InOut[1]* are shifted to the next lower element in the stack array. Then 0 is stored in *InOut[Num-1]*. Finally, *Num* is decremented.

The following example is for when *Size* is UINT#5 and *Num* is UINT#3.

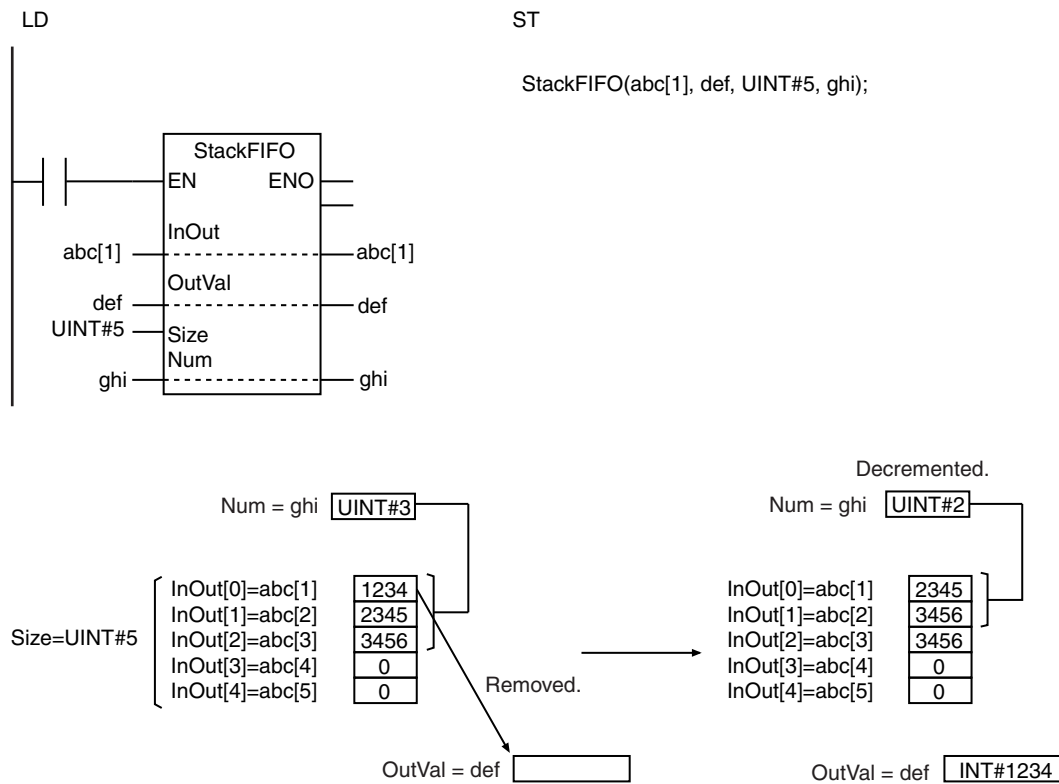

StackLIFO

The StackLIFO instruction removes the top value from a stack. Value of $InOut[Num-1]$ is assigned to $OutVal$. Then, Num is decremented.

The following example is for when $Size$ is $UINT\#5$ and Num is $UINT\#2$.

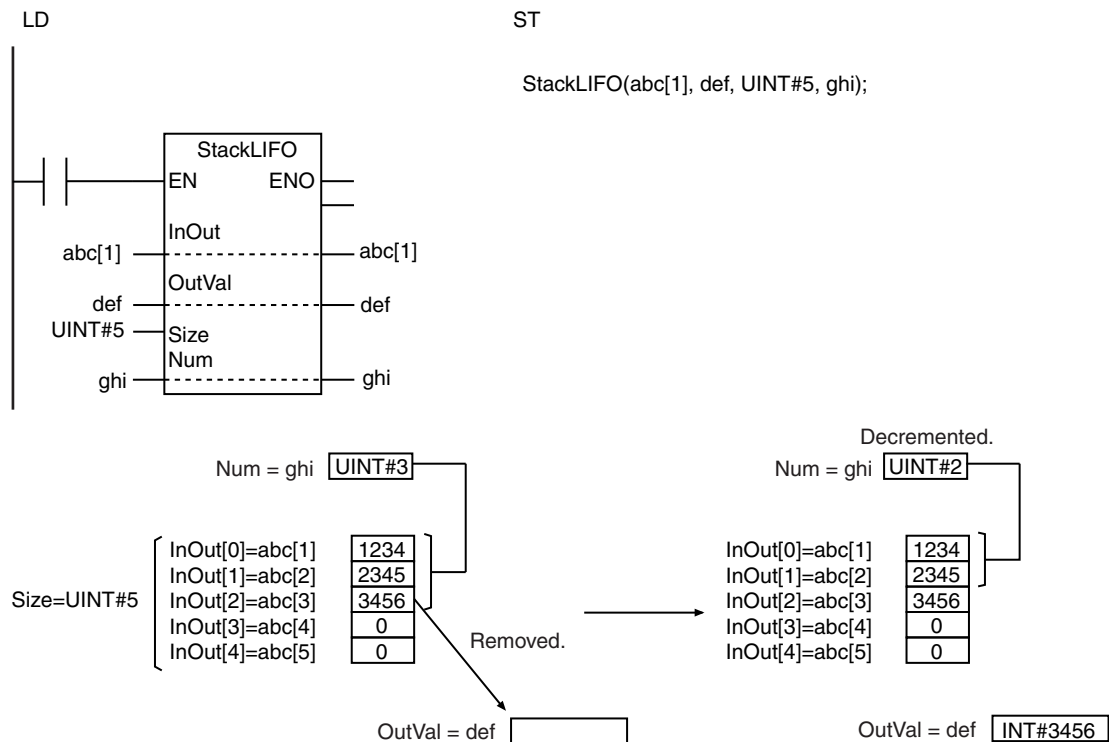

Precautions for Correct Use

- Use the same data type for $InOut[]$ and $OutVal$. If they are different, a building error will occur.
- When an element in the array is passed to $InOut[]$, all elements below the passed element are processed.
- The values in $InOut[]$, Num , and $OutVal$ do not change if the value of $Size$ or Num is 0.
- Return value Out is not used when the instruction is used in ST.
- An error occurs in the following cases. ENO will be FALSE, and $OutVal$ will not change.
 - The values of Num and $Size$ are not 0 and Num is greater than $Size$.
 - The value of $Size$ exceeds the array area of $InOut[]$.
 - $InOut[]$ is a STRING array and any of the elements does not end in a NULL character.
 - $InOut[]$ is a STRING array and the number of bytes in the elements exceeds the size of $OutVal$.

Sample Programming

Refer to the sample programming that is provided for the StackPush instruction (page 2-492).

StackIns

The StackIns instruction inserts a value at a specified position in a stack.

Instruction	Name	FB/FUN	Graphic expression	ST expression
StackIns	Insert into Stack	FUN	<p>The graphic expression shows a box labeled (@)StackIns. On the left side, there are six input lines: EN, In, InOut, Size, Num, and Offset. On the right side, there is one output line labeled Out.</p>	StackIns(In, InOut, Size, Num, Offset);

Variables

Name	Meaning	I/O	Description	Valid range	Unit	Default
In	Insert value	Input	Value, structure, or structure member to insert into the stack	Depends on data type.	---	*
Size	Number of stack elements		Number of stack array elements			1
Offset	Offset		Position in stack at which to insert <i>In</i>			0
InOut[] (array)	Stack array	In-out	Array that functions as stack	Depends on data type.	---	---
Num	Number of stored elements		Number of elements stored in stack			
Out	Return value	Output	Always TRUE	TRUE only	---	---

* If you omit the input parameter, the default value is not applied. A building error will occur.

	Boolean	Bit strings					Integers							Real numbers		Times, durations, dates, and text strings				
	BOOL	BYTE	WORD	DWORD	LWORD	USINT	UINT	UDINT	ULINT	SINT	INT	DINT	LINT	REAL	LREAL	TIME	DATE	TOD	DT	STRING
In	OK	OK	OK	OK	OK	OK	OK	OK	OK	OK	OK	OK	OK	OK	OK	OK	OK	OK	OK	OK
	An enumeration, structure, or structure member can also be specified.																			
Size							OK													
Offset							OK													
InOut[] (array)	Must be an array with elements that have the same data type as <i>In</i> .																			
Num							OK													
Out	OK																			

Function

The instruction assumes that there are number of stored elements *Num* elements stored in stack array *InOut[]*. Insert value *In* is inserted at the position specified by the offset *Offset* (*InOut[Offset]*). All higher elements, i.e., *InOut[Offset]* to *InOut[Num-1]*, are moved to the next higher element in the stack array. Then, *Num* is incremented. For number of stack elements *Size*, specify the number of elements in *InOut[]* to use as a stack.

The following example is for when *Size* is UINT#6, *Num* is UINT#3 and *Offset* is UINT#1.

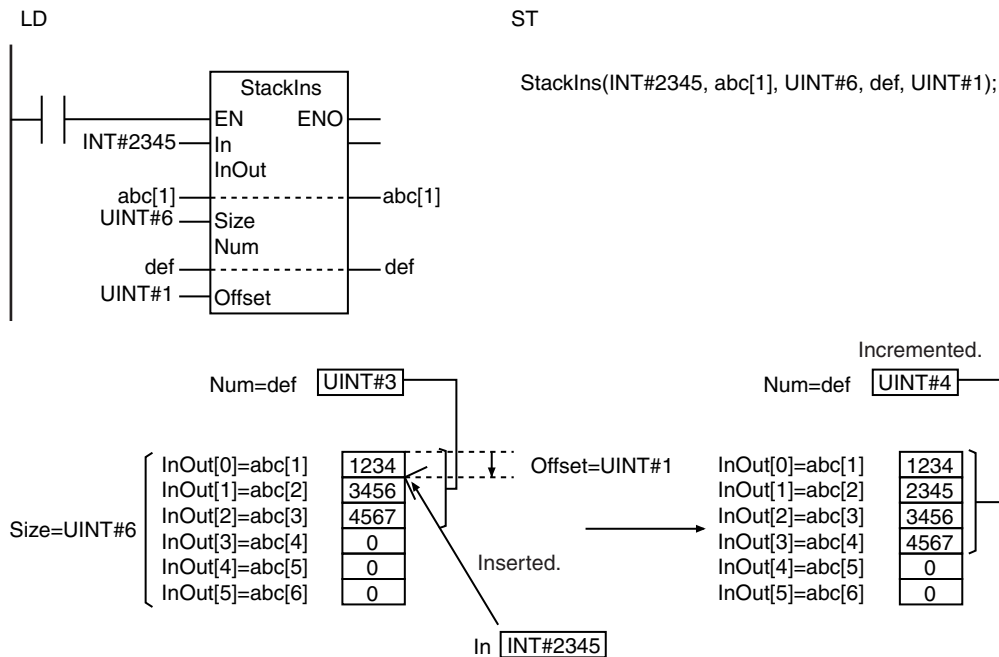

Precautions for Correct Use

- Use the same data type for *In* and *InOut[]*. If they are different, a building error will occur.
- When an element in the array is passed to *InOut[]*, all elements below the passed element are processed.
- The values in *InOut[]* and *Num* do not change if the value of *Size* is 0.
- Always use a variable for the input parameter to pass to *In*. A building error will occur if a constant is passed.
- If *In* is an enumeration, you cannot directly pass an enumerator to it. A building error will occur if an enumerator is passed to it directly.
- Return value *Out* is not used when the instruction is used in ST.
- An error occurs in the following cases. *ENO* will be FALSE, and *InOut[]* will not change.
 - The value of *Size* is not 0 and *Size* is not greater than *Num* and *Num* is not greater than or equal to *Offset*.
 - The value of *Size* exceeds the array area of *InOut[]*.
 - *In* and *InOut[]* are STRING data and the number of bytes in *In* exceeds the size of *InOut[]*.

Sample Programming

Refer to the sample programming that is provided for the StackPush instruction (page 2-492).

StackDel

The StackDel instruction deletes a value from a specified position in a stack.

Instruction	Name	FB/FUN	Graphic expression	ST expression
StackDel	Delete from Stack	FUN		StackDel(InOut, Size, Num, Offset);

Variables

Name	Meaning	I/O	Description	Valid range	Unit	Default
Size	Number of stack elements	Input	Number of stack array elements	Depends on data type.	---	1
Offset	Offset		Offset of value to delete from stack			0
InOut[] (array)	Stack array	In-out	Array that functions as stack	Depends on data type.	---	---
Num	Number of stored elements		Number of elements stored in stack			
Out	Return value	Output	Always TRUE	TRUE only	---	---

	Boolean	Bit strings					Integers							Real numbers		Times, durations, dates, and text strings				
	BOOL	BYTE	WORD	DWORD	LWORD	USINT	UINT	UDINT	ULINT	SINT	INT	DINT	LINT	REAL	LREAL	TIME	DATE	TOD	DT	STRING
Size							OK													
Offset							OK													
InOut[] (array)	OK	OK	OK	OK	OK	OK	OK	OK	OK	OK	OK	OK	OK	OK	OK	OK	OK	OK	OK	OK
Num							OK													
Out	OK																			

Arrays of enumerations or structures can also be specified.

Function

The instruction assumes that there are number of stored elements *Num* elements stored in stack array *InOut[]*. The value is deleted from the position specified by the offset *Offset* (*InOut[Offset]*). All higher elements, i.e., *InOut[Offset+1]* to *InOut[Num-1]*, are moved to the next lower element in the stack array. Then, *Num* is decremented. For number of stack elements *Size*, specify the number of elements in *InOut[]* to use as a stack.

The following example is for when *Size* is UINT#6, *Num* is UINT#3 and *Offset* is UINT#1.

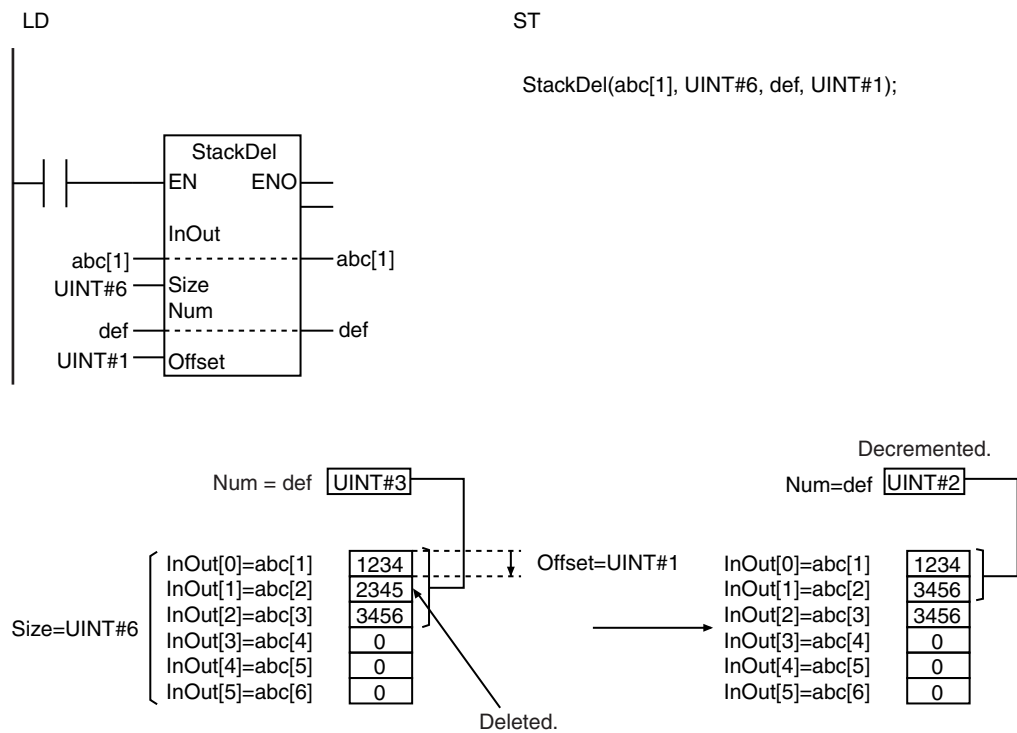

Precautions for Correct Use

- When an element in the array is passed to *InOut[]*, all elements below the passed element are processed.
- The values in *InOut[]* and *Num* do not change if the value of *Size* or *Num* is 0.
- Return value *Out* is not used when the instruction is used in ST.
- An error occurs in the following cases. *ENO* will be FALSE, and *InOut[]* will not change.
 - The values of *Num* and *Size* are not 0 and *Size* is not greater than or equal to *Num* and *Num* is not greater than *Offset*.
 - The value of *Size* exceeds the array area of *InOut[]*.

RecSearch

The RecSearch instruction searches an array of structures for elements that match the search key with the specified method.

Instruction	Name	FB/FUN	Graphic expression	ST expression
RecSearch	Record Search	FUN	<pre> (@)RecSearch EN ENO In Out Size Num Member Key Mode InOutPos </pre>	Out:=RecSearch(In, Size, Member, Key, Mode, InOutPos, Num);

Variables

Name	Meaning	I/O	Description	Valid range	Unit	Default
In[] (array)	Array to search	Input	Array of structures to search	---	---	*
Size	Number of elements to search		Number of array elements to search	Depends on data type.		1
Member	Member to search		Member of In[] structure to search			*
Key	Search key		Search value			
Mode	Search method		Search method	_LINEAR, _BIN_ASC, _BIN_DESC		_LIN- EAR
InOutPos[] (array)	Element numbers of matching elements	In-out	Element numbers of matching elements	Depends on data type.	---	---
Out	Search result	Output	TRUE: There are elements that match conditions FALSE: There are no elements that match conditions	Depends on data type.	---	---
Num	Number of matches		Number of matches			

* If you omit the input parameter, the default value is not applied. A building error will occur.

	Boolean	Bit strings				Integers							Real numbers		Times, durations, dates, and text strings					
	BOOL	BYTE	WORD	DWORD	LWORD	USINT	UINT	UDINT	ULINT	SINT	INT	DINT	LINT	REAL	LREAL	TIME	DATE	TOD	DT	STRING
In[] (array)	Specify an array of structures.																			
Size							OK													
Member						OK	OK	OK	OK	OK	OK	OK	OK	OK	OK	OK	OK	OK	OK	OK
	Specify the same data type as the search member of <i>In[]</i>																			
Key	Must be the same data type as <i>Member</i> .																			
Mode	Refer to <i>Function</i> for the enumerators of the enumerated type <code>_eSEARCH_MODE</code> .																			
InOutPos[] (array)							OK													
Out	OK																			
Num							OK													

* You can specify TIME, DATE, TOD, DT, and STRING data with CPU Units with unit version 1.01 or later and Sysmac Studio version 1.02 or higher.

Function

The RecSearch instruction searches *Size* elements in the array of structures *In[]*. The search range is therefore from *In[0]* to *In[Size-1]*. The instruction searches member to search *Member* in the structures for members that match the search key *Key*.

One of the members to search in the elements of *In[]* is passed as an argument to *Member*.

If any matching elements are found, the value of search result *Out* changes to TRUE. The element number of the matching element is assigned to *InOutPos[0]* and the number of matching elements is assigned to *Num*. If there is more than one matching element, the element number of the lowest matching element in *In[]* is assigned to *InOutPos[0]*. If there are no matching elements, the value of *Out* will be FALSE and *InOutPos[0]* and *Num* will be 0.

Always attach the element number to input parameter that is passed to *In[]*, e.g., *array[3]*.

The data type of search method *Mode* is enumerated type `_eSEARCH_MODE`. The meanings of the enumerators are as follows:

Enumerator	Meaning
<code>_LINEAR</code>	Linear search
<code>_BIN_ASC</code>	Ascending binary search
<code>_BIN_DESC</code>	Descending binary search

For a linear search, the search is performed in order from the first element of *In[]*.

The following example is for when *Size* is *UINT#5*, *Key* is *INT#1234* and *Mode* is *_LINEAR*.

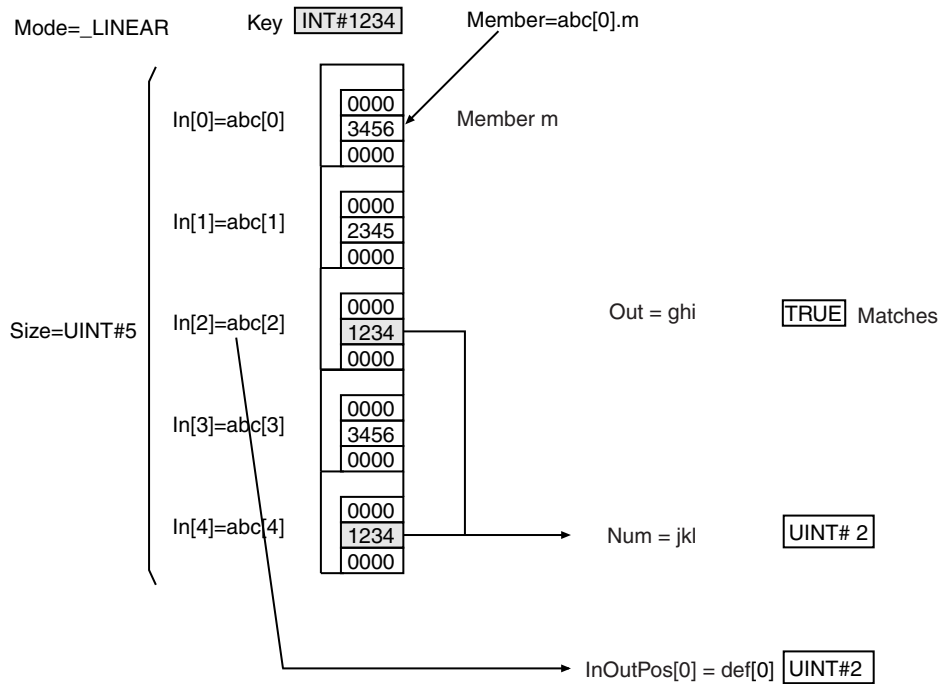
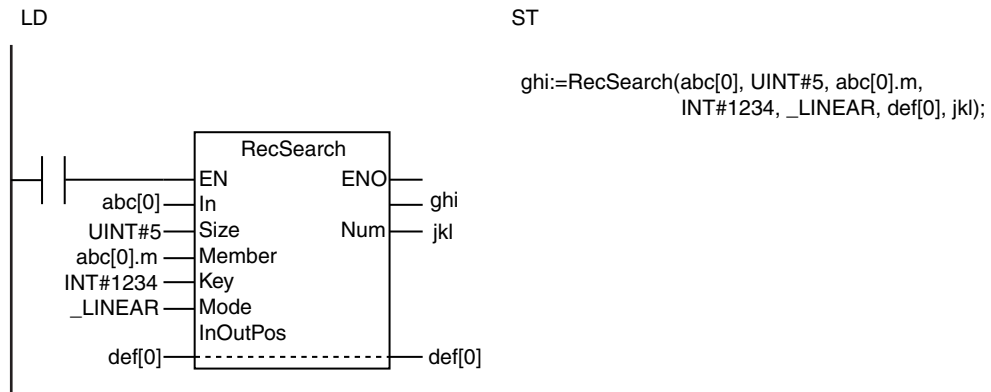

For an ascending binary search, the array elements in the input parameter that is passed to *In[]* must be in ascending order before this instruction is executed. Then a binary search is performed by executing this instruction.

Using the same example as before, the order of the array elements and the processing results will be as shown below for an ascending binary search.

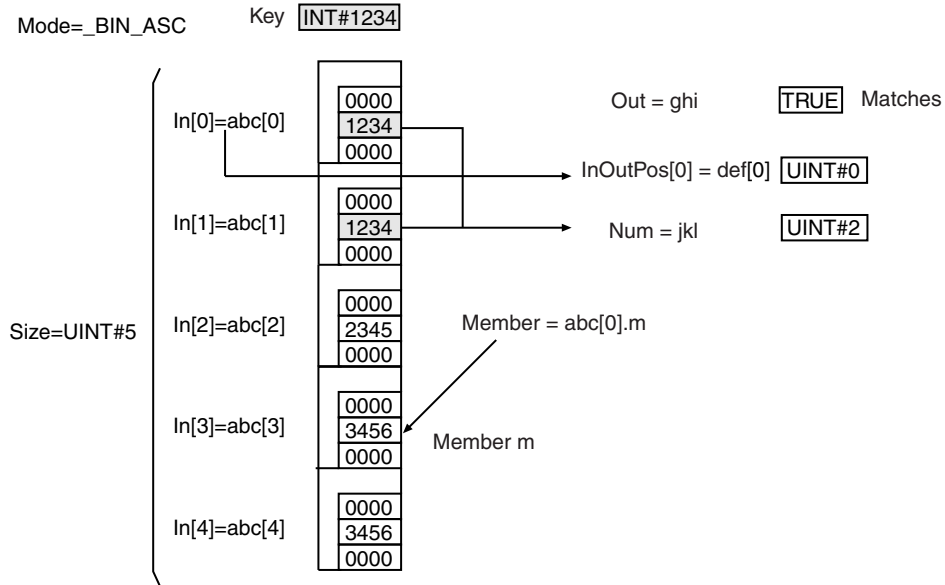

For a descending binary search, the array elements in the input parameter that is passed to *In[]* must be in descending order before this instruction is executed. Then a binary search is performed by executing this instruction.

Using the same example as before, the order of the array elements and the processing results will be as shown below for a descending binary search.

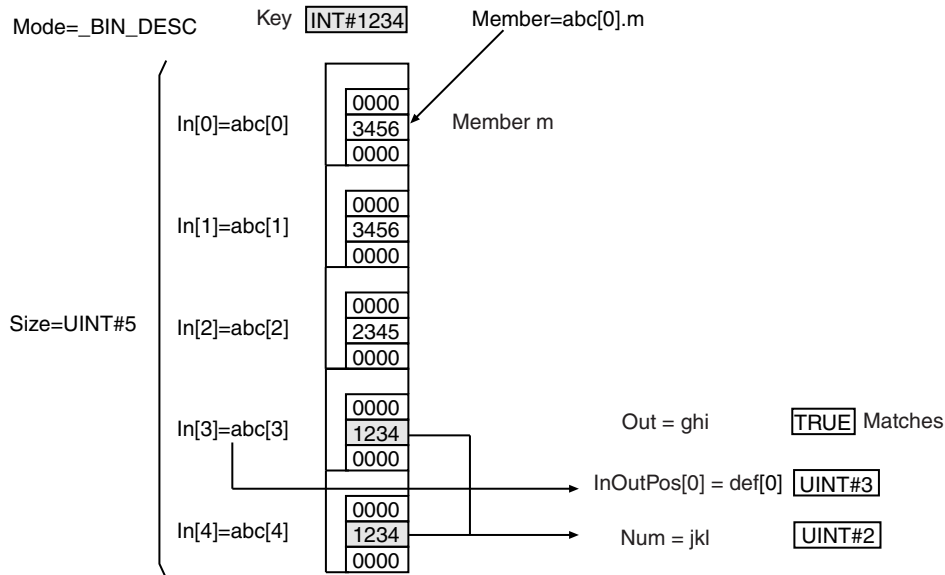

Additional Information

- *In[]* can be a member of a higher-level structure.
Example: `In[0]=str0.str1[0]`
- *In[]* can be an array with two or more dimensions. If *In[]* is a two-dimensional array, the element number in the first dimension of the element that matches the search conditions is assigned to *InOutPos[0]* and the element number in the second dimension is assigned to *InOutPos[1]*.

- If *In[]* is a three-dimensional array, the element number in the first dimension of the element that matches the search conditions is assigned to *InOutPos[0]*, the element number in the second dimension is assigned to *InOutPos[1]*, and the element number in the third dimension is assigned to *InOutPos[2]*.
- When you search TIME, DT, or TOD data, adjust the data so that the precision of *Member* and *Key* is the same. Use the following instructions to adjust the precision of the values: *TruncTime* (page 2-652), *TruncDt* (page 2-656), and *TruncTod* (page 2-660).

Precautions for Correct Use

- Use an array that is the element of a structure for *In[]*. Otherwise, a building error will occur.
- The data types of *Key* and *Member* must be the same. If they are different, a building error will occur.
- When an element in the array is passed to *In[]*, all elements below the passed element are processed.
- If *Member* is a real number, depending on the value of *Member*, the desired results may not be achieved due to error.
- If *Key* is a real number, do not specify nonnumeric data for *Key*.
- If the value of *Size* is 0, the value of *Out* is FALSE and the value of *Num* is 0. *InOutPos[]* does not change.
- The correct result is not obtained if the value of *Mode* is *_BIN_ASC* or *_BIN_DESC* and the elements of *In[]* are not in ascending or descending order. Place the elements in ascending or descending order before executing this instruction.
- An error occurs in the following cases. *ENO* will be FALSE, and *Out*, *InOutPos[]*, and *Num* will not change.
 - The value of *Mode* is outside of the valid range.
 - The value of *Size* exceeds the array area of *In[]*.
 - *Member* is not a member of *In[]*.
 - The array size of *InOutPos[]* is smaller than the number of dimensions of *In[]*.
 - *Member* is STRING data and it does not end in a NULL character.

RecRangeSearch

The RecRangeSearch instruction searches an array of structures for elements that match the search condition range with the specified method.

Instruction	Name	FB/FUN	Graphic expression	ST expression
RecRangeSearch	Range Record Search	FUN		Out:=RecRangeSearch(In, Size, Member, MN, MX, Condition, Mode, InOutPos, Num);

Variables

Name	Meaning	I/O	Description	Valid range	Unit	Default	
In[] (array)	Array to search	Input	Array of structures to search	---	---	*	
Size	Number of elements to search		Number of array elements to search	Depends on data type.		1	
Member	Member to search		Member of In[] structure to search			*	
MN	Search condition lower limit		Search condition lower limit			_EQ_BOTH, _EQ_MIN, _EQ_MAX, _NE_BOTH	_EQ_BOTH
MX	Search condition upper limit		Search condition upper limit				
Condition	Search condition		Search condition			_LINEAR, _BIN_ASC, _BIN_DESC	_LIN-EAR
Mode	Search method		Search method				
InOutPos[] (array)	Element numbers of matching elements	In-out	Element numbers of matching elements	Depends on data type.	---	---	
Out	Search result	Output	TRUE: There are elements that match conditions FALSE: There are no elements that match conditions	Depends on data type.	---	---	
Num	Number of matches		Number of matches				

* If you omit the input parameter, the default value is not applied. A building error will occur.

	Boolean	Bit strings				Integers							Real numbers	Times, durations, dates, and text strings						
	BOOL	BYTE	WORD	DWORD	LWORD	USINT	UINT	UDINT	ULINT	SINT	INT	DINT	LINT	REAL	LREAL	TIME	DATE	TOD	DT	STRING
In[] (array)	Specify an array of structures.																			
Size							OK													
Member						OK	OK	OK	OK	OK	OK	OK	OK	OK	OK	OK	OK	OK	OK	OK
	Specify the same data type as the search member of In[].																			
MN	Must be the same data type as Member.																			
MX	Must be the same data type as Member.																			
Condition	Refer to <i>Function</i> for the enumerators for the enumerated type <code>_eSEARCH_CONDITION</code> .																			
Mode	Refer to <i>Function</i> for the enumerators for the enumerated type <code>_eSEARCH_MODE</code> .																			
InOutPos[] (array)							OK													
Out	OK																			
Num							OK													

* You can specify TIME, DATE, TOD, DT, and STRING data with CPU Units with unit version 1.01 or later and Sysmac Studio version 1.02 or higher.

Function

The RecRangeSearch instruction searches Size elements in the array of structures In[]. The search range is therefore from In[0] to In[Size-1]. The instruction searches member to search Member in the structures for members that match the search condition.

Condition specifies the search condition. Mode specifies the search method. Details are provided below. One of the members to search in the elements of In[] is passed as an argument to Member.

If any elements that match the search condition are found, the value of search result Out changes to TRUE. The element number of the matching element is assigned to InOutPos[0] and the number of matching elements is assigned to Num. If there is more than one matching element, the element number of the lowest matching element in In[] is assigned to InOutPos[0]. If there are no matching elements, the value of Out will be FALSE and InOutPos[0] and Num will be 0.

Always attach the element number to input parameter that is passed to In[], e.g., array[3].

The data type of search condition Condition is enumerated type `_eSEARCH_CONDITION`. The meanings of the enumerators are as follows:

Enumerator	Meaning
<code>_EQ_BOTH</code>	$MN \leq Member \leq MX$
<code>_EQ_MIN</code>	$MN \leq Member < MX$
<code>_EQ_MAX</code>	$MN < Member \leq MX$
<code>_NE_BOTH</code>	$MN < Member < MX$

The data type of search method *Mode* is enumerated type `_eSEARCH_MODE`. The meaning of the enumerators are as follows:

Enumerator	Meaning
<code>_LINEAR</code>	Linear search
<code>_BIN_ASC</code>	Ascending binary search
<code>_BIN_DESC</code>	Descending binary search

For a linear search, the search is performed in order from the first element of *In[]*.

The following example is for when *Size* is `UINT#5`, *MN* is `INT#1000`, *MX* is `INT#2000`, *Condition* is `_EQ_BOTH` and *Mode* is `_LINEAR`.

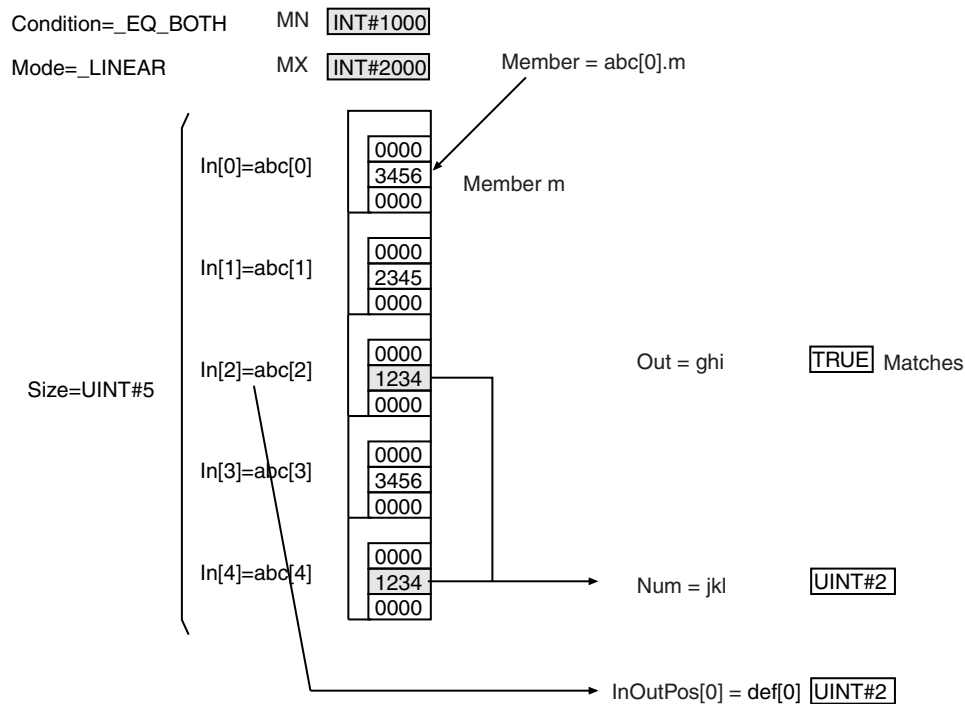
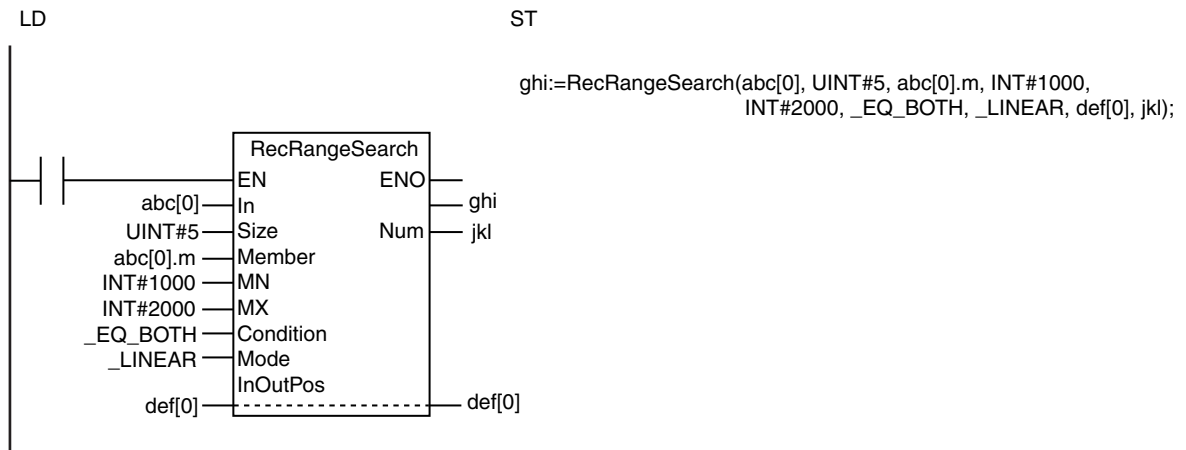

For an ascending binary search, the array elements in the input parameter that is passed to *In[]* must be in ascending order before this instruction is executed. Then a binary search is performed by executing this instruction.

Using the same example as before, the order of the array elements and the processing results will be as shown below for an ascending binary search.

Condition=_EQ_BOTH MN INT#1000

Mode=_BIN_ASC MX INT#2000

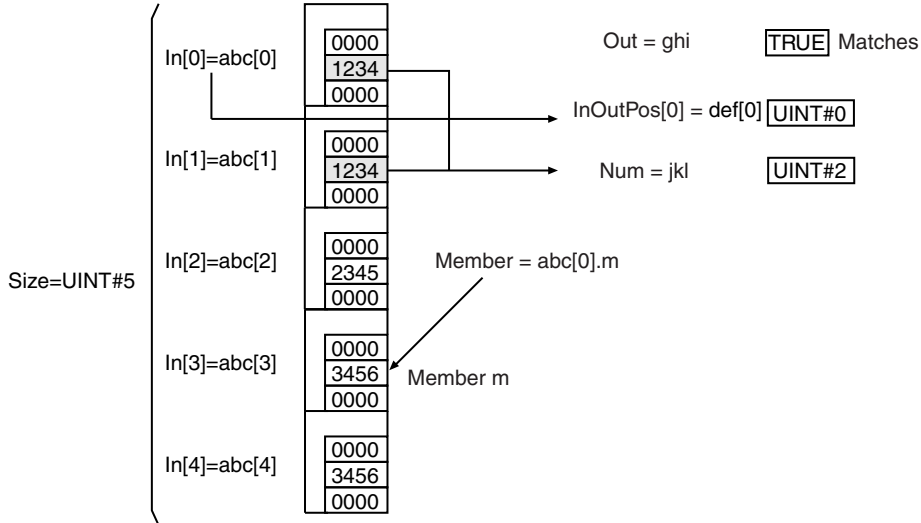

For a descending binary search, the array elements in the input parameter that is passed to *In[]* must be in descending order before this instruction is executed. Then a binary search is performed by executing this instruction.

Using the same example as before, the order of the array elements and the processing results will be as shown below for a descending binary search.

Condition=_EQ_BOTH MN INT#1000

Mode=_LINEAR MX INT#2000

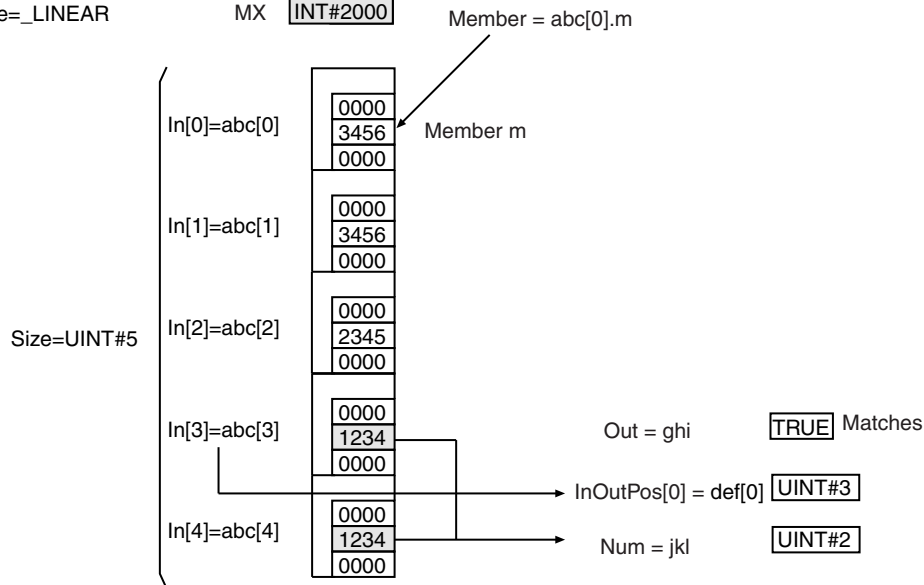

Additional Information

- *In[]* can be a member of a higher-level structure.
Example: `In[0]=str0.str1[0]`
- *In[]* can be an array with two or more dimensions. If *In[]* is a two-dimensional array, the element number in the first dimension of the element that matches the search conditions is assigned to *InOutPos[0]* and the element number in the second dimension is assigned to *InOutPos[1]*.
- If *In[]* is a three-dimensional array, the element number in the first dimension of the element that matches the search conditions is assigned to *InOutPos[0]*, the element number in the second dimension is assigned to *InOutPos[1]*, and the element number in the third dimension is assigned to *InOutPos[2]*.
- When you search TIME, DT, or TOD data, adjust the data so that the precision of *Member*, *MN*, and *MX* is the same. Use the following instructions to adjust the precision of the values: *TruncTime* (page 2-652), *TruncDt* (page 2-656), and *TruncTod* (page 2-660).

Precautions for Correct Use

- Make the data types of *Member*, *MN*, and *MX* the same as the data type of the members that are searched in *In[]*. Otherwise, a building error will occur.
- Use an array that is the element of a structure for *In[]*. Otherwise, a building error will occur.
- When an element in the array is passed to *In[]*, all elements below the passed element are processed.
- If *Member* is a real number, depending on the value of *Member*, the desired results may not be achieved due to error.
- If *MN* or *MX* is a real number, do not specify nonnumeric data for *MN* or *MX*.
- If the value of *Size* is 0, the value of *Out* is FALSE and the value of *Num* is 0. *InOutPos[]* does not change.
- The correct result is not obtained if the value of *Mode* is `_BIN_ASC` or `_BIN_DESC` and the elements of *In[]* are not in ascending or descending order. Place the elements in ascending or descending order before executing this instruction.
- An error occurs in the following cases. *ENO* will be FALSE, and *Out*, *InOutPos[]*, and *Num* will not change.
 - *MN* is greater than *MX*.
 - The value of *Condition* is outside of the valid range.
 - The value of *Mode* is outside of the valid range.
 - The value of *Size* exceeds the array area of *In[]*.
 - *Member* is not a member of *In[]*.
 - The array size of *InOutPos[]* is smaller than the number of dimensions of *In[]*.

RecSort

The RecSort instruction sorts the elements of an array of structures.

Instruction	Name	FB/FUN	Graphic expression	ST expression
RecSort	Record Sort	FB		RecSort_instance(Execute, InOut, Size, Member, Order, Done, Busy, Error);

Variables

Name	Meaning	I/O	Description	Valid range	Unit	Default
Size	Number of elements to sort	Input	Number of array elements to sort	Depends on data type.	---	1
Member	Member to sort		Member of <i>In[]</i> structure to sort			*
Order	Sort order		Sort order			_ASC, _DESC
InOut[] (array)	Sort array	In-out	Array of structures to sort	---	---	---

* If you omit the input parameter, the default value is not applied. A building error will occur.

	Boolean	Bit strings				Integers								Real numbers	Times, durations, dates, and text strings					
	BOOL	BYTE	WORD	DWORD	LWORD	USINT	UINT	UDINT	ULINT	SINT	INT	DINT	LINT	REAL	LREAL	TIME	DATE	TOD	DT	STRING
Size							OK													
Member						OK	OK	OK	OK	OK	OK	OK	OK	OK	OK					OK
	Specify the same data type as the sort member of <i>InOut[]</i>																			
Order	Refer to <i>Function</i> for the enumerators of the enumerated type <code>_eSORT_ORDER</code> .																			
InOut[] (array)	Specify an array of structures.																			

* You can specify TIME, DATE, TOD, DT, and STRING data with CPU Units with unit version 1.01 or later and Sysmac Studio version 1.02 or higher.

Function

When the value of *Execute* is TRUE, *Size* elements of *InOut[]* (a structure array) is sorted. Specifically, the elements from *InOut[0]* to *InOut[Size-1]* are sorted. Specifically, the elements from *InOut[0]* to *InOut[Size-1]* are sorted. *Order* specifies the sort order. Details are provided below. One of the members to sort in the elements of *In[]* is passed as an argument to *Member*.

Always attach the element number to the in-out parameter that is passed to *InOut[]*, e.g., *array[3]*.

The data type of sort order *Order* is enumerated type *_eSORT_ORDER*. The meaning of the enumerators are as follows:

Enumerator	Meaning
_ASC	Ascending
_DESC	Descending

The relationship between values with data types that are not integers or real numbers are determined as given in the following table.

Data type	Relationship
TIME	The numerically larger value is considered to be larger.
DATE, TOD, or DT	Later dates or times of day are considered to be larger.
STRING	The specifications are the same as for the LTascii, LEascii, GTascii, and GEascii instructions (page 2-104). Refer to the specified page for details.

The following example is for when *Size* is UINT#5, *Member* is 3456 and *Order* is *_Asc*.

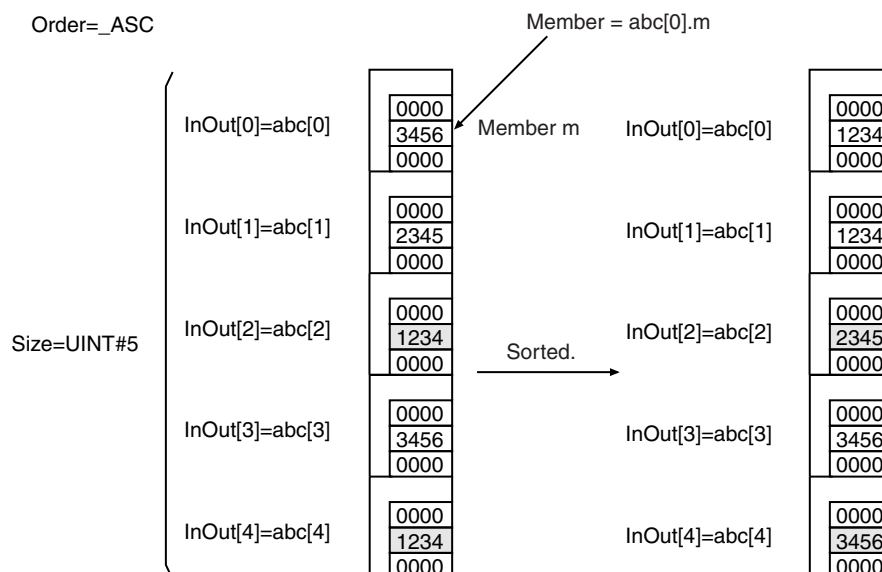
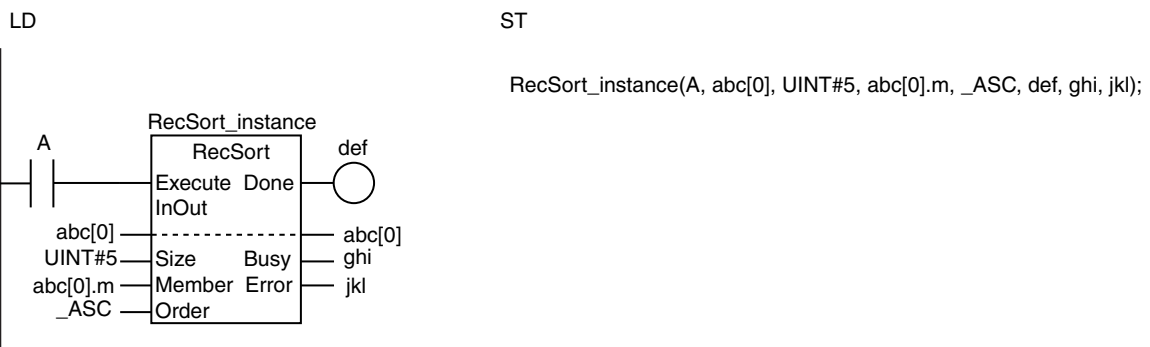

Additional Information

- If the power supply is interrupted during execution of this instruction, the contents of *InOut* may be corrupted. If you back up the contents of *InOut[]* each time the instruction is completed normally, you can restore the data if it is corrupted. Refer to *Sample Programming*.
- When you sort TIME, DT, or TOD data, adjust the data so that the precision of *Member* is the same. Use the following instructions to adjust the precision of the values: *TruncTime* (page 2-652), *TruncDt* (page 2-656), and *TruncTod* (page 2-660).

Precautions for Correct Use

- Use an array that is the element of a structure for *InOut[]*. Otherwise, a building error will occur.
- Execution of this instruction is continued until processing is completed even if the value of *Execute* changes to *FALSE* or the execution time exceeds the task period. The value of *Done* changes to *TRUE* when processing is completed. Use this to confirm normal completion of processing.
- Refer to *Using this Section* on page 2-3 for a timing chart for *Execute*, *Done*, *Busy*, and *Error*.
- If *Member* is a real number, depending on the value of *Member*, the desired results may not be achieved due to error.
- When an element in the array is passed to *InOut[]*, all elements below the passed element are processed.
- If the value of *Size* is 0, the value of *Done* will be *TRUE* and *InOut[]* will not change.
- An error occurs in the following cases. *Done* and *Busy* will be *FALSE* and *Error* will be *TRUE*.
 - The value of *Order* is outside of the valid range.
 - The value of *Size* exceeds the array area of *InOut[]*.
 - *Member* is not a member of *InOut[]*.
 - *Member* is *STRING* data and it does not end in a *NULL* character.

Sample Programming

In this sample, the *RecSort* instruction is used to sort an array *Abc[]* of *MyStr* structures in ascending order. The member to sort is *Abc[]*.m. To prevent losing data even if power is interrupted during processing, *Abc[]* is backed up in a variable named *Abc_backup[]* before sorting. If a power interruption occurs, the contents of *Abc_backup[]* is restored to *Abc[]* and the sort operation is redone.

Definitions of Global Variables

Data Types

Variable	Data type	Comment
MyStr	STRUCT	Structure
l	BOOL	Member
m	INT	Member
n	REAL	Member

Global Variables

Variable	Data type	Initial value	Retain	Comment
Abc	ARRAY[0..4] OF MyStr	[5((l:=FALSE, m:=0, n:=0.0))]	✓	Sort array
Abc_backup	ARRAY[0..4] OF MyStr	[5((l:=FALSE, m:=0, n:=0.0))]	✓	Backup of <i>Abc[]</i>

LD

Internal Variables	Variable	Data type	Initial value	Retain	Comment
	Sorting	BOOL	FALSE	✓	Processing (retained)
	OperatingEnd	BOOL	FALSE		Processing completed
	Trigger	BOOL	FALSE		Execution condition
	Operating	BOOL	FALSE		Processing
	RS_instance	RS			
	RecSort_instance	RecSort			

External Variables	Variable	Data type	Comment
	Abc	ARRAY[0..4] OF MyStr	Sort array
	Abc_backup	ARRAY[0..4] OF MyStr	Backup of <i>Abc</i> []

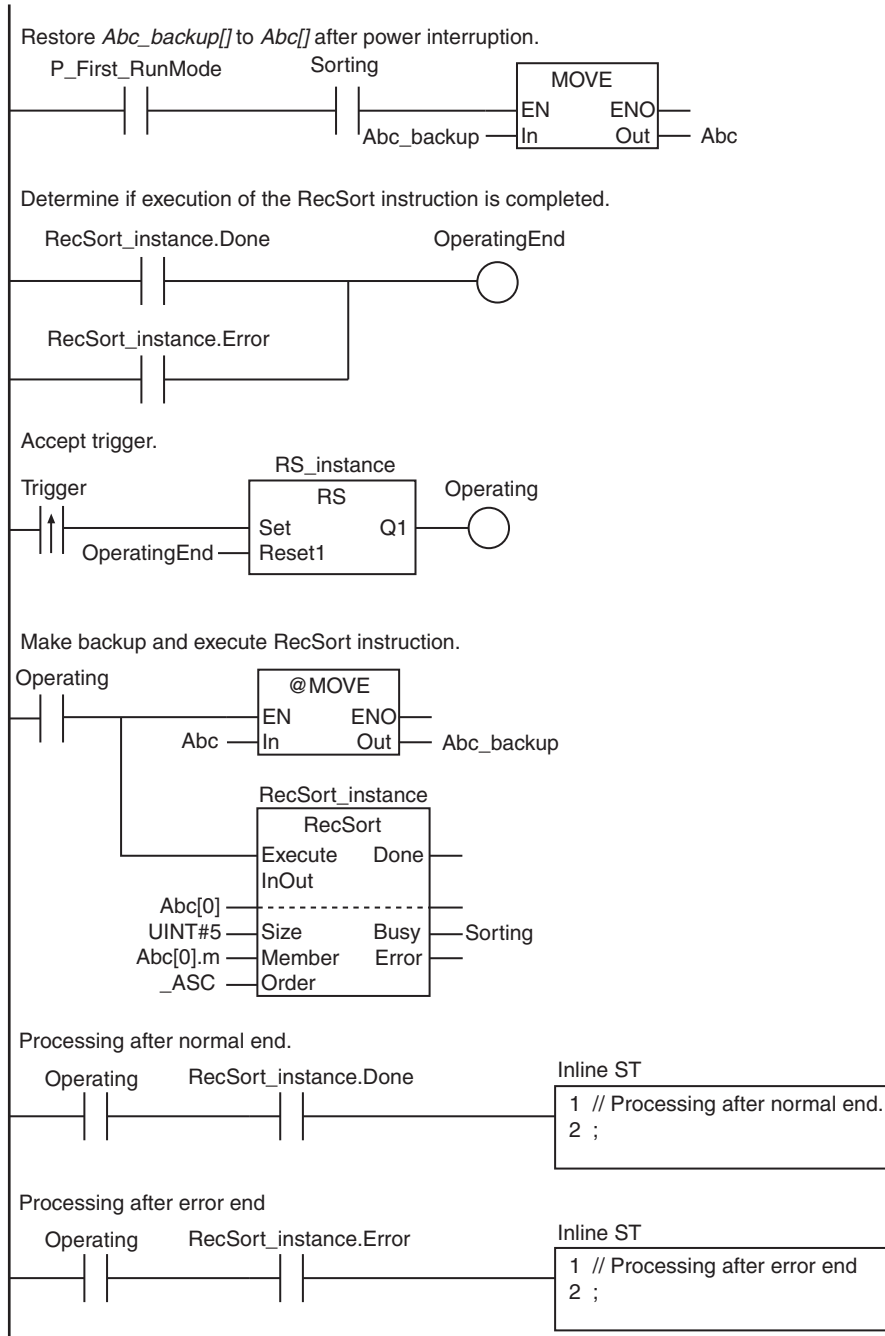

ST

Internal Variables	Variable	Data type	Initial value	Retain	Comment
	Sorting	BOOL	FALSE	✓	Processing (retained)
	Trigger	BOOL	FALSE		Execution condition
	LastTrigger	BOOL	FALSE		Value of <i>Trigger</i> from previous task period
	OperatingStart	BOOL	FALSE		Processing started
	Operating	BOOL	FALSE		Processing
	RS_instance	RS			
	RecSort_instance	RecSort			

External Variables	Variable	Data type	Comment
	Abc	ARRAY[0..4] OF MyStr	Sort array
	Abc_backup	ARRAY[0..4] OF MyStr	Backup of <i>Abc</i>]

```
// Restore Abc_backup[] to Abc[] after power interruption.
IF ( (P_First_RunMode = TRUE) AND (Sorting = TRUE) ) THEN
  Abc:=Abc_backup;
END_IF;
```

```
// Detect when Trigger changes to TRUE.
IF ( (Trigger=TRUE) AND (LastTrigger=FALSE) ) THEN
  OperatingStart :=TRUE;
  Operating      :=TRUE;
END_IF;
LastTrigger:=Trigger;
```

```
// Initialize RecSort instruction.
IF (OperatingStart=TRUE) THEN
  Abc_backup:=Abc;
  RecSort_instance(
    Execute :=FALSE,    // Start condition
    InOut   :=Abc[0],  // Sort array
    Member  :=Abc[0].m); // Member to sort
  OperatingStart:=FALSE;
END_IF;
```

```
// Execute RecSort instruction.
IF (Operating=TRUE) THEN
  RecSort_instance(
    Execute:=TRUE,
    InOut   :=Abc[0],
    Size    :=UINT#5,
    Member  :=Abc[0].m,
    Order   :=_ASC,
    Busy    =>Sorting);

  IF (RecSort_instance.Done=TRUE) THEN
    // Processing after normal end.
    Operating:=FALSE;
  END_IF;

  IF (RecSort_instance.Error=TRUE) THEN
    // Processing after error end.
    Operating:=FALSE;
  END_IF;
END_IF;
```

RecNum

The RecNum instruction finds the number of records in an array of structures to the end data.

Instruction	Name	FB/FUN	Graphic expression	ST expression
RecNum	Get Number of Records	FUN		Out:=RecNum(In, Member, EndDat);

Variables

Name	Meaning	I/O	Description	Valid range	Unit	Default
In[] (array)	Array to process	Input	Array of structures to process	---	---	*
Member	Member to process		Member of In[] structure to process	Depends on data type.		
EndDat	End data		End data	Depends on data type.		
Out	Number of records	Output	Number of records	Depends on data type.	---	---

* If you omit the input parameter, the default value is not applied. A building error will occur.

	Boolean	Bit strings					Integers							Real numbers	Times, durations, dates, and text strings					
	BOOL	BYTE	WORD	DWORD	LWORD	USINT	UINT	UDINT	ULINT	SINT	INT	DINT	LINT	REAL	LREAL	TIME	DATE	TOD	DT	STRING
In[] (array)	Specify an array of structures.																			
Member	OK	OK	OK	OK	OK	OK	OK	OK	OK	OK	OK	OK	OK	OK	OK	OK	OK	OK	OK	OK
	Enumerations can also be specified.*2																			
	Must be the same data type as the members to process in In[].																			
EndDat	Must be the same data type as Member.																			
Out							OK													

*1 You can specify TIME, DATE, TOD, and DT data with CPU Units with unit version 1.01 or later and Sysmac Studio version 1.02 or higher.

*2 A CPU Unit with unit version 1.02 or later and Sysmac Studio version 1.03 or higher are required to specify enumerations.

Function

The RecNum instruction searches from the start of an array In[] (whose elements are structures). The instruction searches for elements for which the value of member to process Member matches end data EndDat. As the result, it assigns the number of elements (records) up to the element just before the element with an EndDat match to Out. One of the members to process in the elements of In[] is passed as an argument to Member.

Always attach the element number to input parameter that is passed to In[], e.g., array[3].

RecMax and RecMin

RecMax: Searches the specified member in the structures of an array of structures for the maximum value.

RecMin: Searches the specified member in the structures of an array of structures for the minimum value.

Instruction	Name	FB/FUN	Graphic expression	ST expression
RecMax	Maximum Record Search	FUN		Out:=RecMax(In, Size, Member, InOutPos, Num);
RecMin	Minimum Record Search	FUN		Out:=RecMin(In, Size, Member, InOutPos, Num);

Variables

Name	Meaning	I/O	Description	Valid range	Unit	Default
In[] (array)	Array to search	Input	Array of structures to search	---		*
Size	Number of elements to search		Number of array elements to search	Depends on data type.	---	1
Member	Member to search		Member of In[] structure to search			*
InOutPos[] (array)	Found element number	In-out	Found element number	Depends on data type.	---	---
Out	Search result	Output	Search result	Depends on data type.	---	---
Num	Number found		Number found			

* If you omit the input parameter, the default value is not applied. A building error will occur.

	Boolean	Bit strings					Integers							Real numbers	Times, durations, dates, and text strings						
	BOOL	BYTE	WORD	DWORD	LWORD	USINT	UINT	UDINT	ULINT	SINT	INT	DINT	LINT	REAL	LREAL	TIME	DATE	TOD	DT	STRING	
In[] (array)																					
Size							OK														

	Boolean	Bit strings				Integers							Real numbers	Times, durations, dates, and text strings							
	BOOL	BYTE	WORD	DWORD	LWORD	USINT	UINT	UDINT	ULINT	SINT	INT	DINT	LINT	REAL	LREAL	TIME	DATE	TOD	DT	STRING	
Member						OK	OK	OK	OK	OK	OK	OK	OK	OK	OK	OK	OK	OK	OK	OK	
	Specify the same data type as the search member of <i>In[]</i> .																				
InOutPos[] (array)						OK															
Out						OK	OK	OK	OK	OK	OK	OK	OK	OK	OK	OK	OK	OK	OK	OK	
Num						OK															

* You can specify TIME, DATE, TOD, DT, and STRING data with CPU Units with unit version 1.01 or later and Sysmac Studio version 1.02 or higher.

Function

These instructions search *Size* elements in an array of structures *In[]*. The search range is therefore from *In[0]* to *In[Size-1]*. The instruction searches member to search *Member* in the structures.

One of the members to search in the elements of *In[]* is passed as an argument to *Member*. The element number of the element with the maximum or minimum value is assigned to *InOutPos[0]* and the number of elements that were found is assigned to *Num*. If more than one element was found, the element number of the lowest element with the maximum or minimum value in *In[]* is assigned to *InOutPos[0]*.

Always attach the element number to input parameter that is passed to *In[]*, e.g., *array[3]*.

The relationship between values with data types that are not integers or real numbers are determined as given in the following table.

Data type	Relationship
TIME	The numerically larger value is considered to be larger.
DATE, TOD, or DT	Later dates or times of day are considered to be larger.
STRING	The specifications are the same as for the LTascii, LEascii, GTascii, and GEascii instructions (page 2-104). Refer to the specified page for details.

● RecMax

The RecMax instruction searches for the maximum value. The maximum value of the member to search is assigned to search result *Out*.

● RecMin

The RecMin instruction searches for the minimum value. The minimum value of the member to search is assigned to search result *Out*.

The following example shows the RecMax instruction when *Size* is UINT#5.

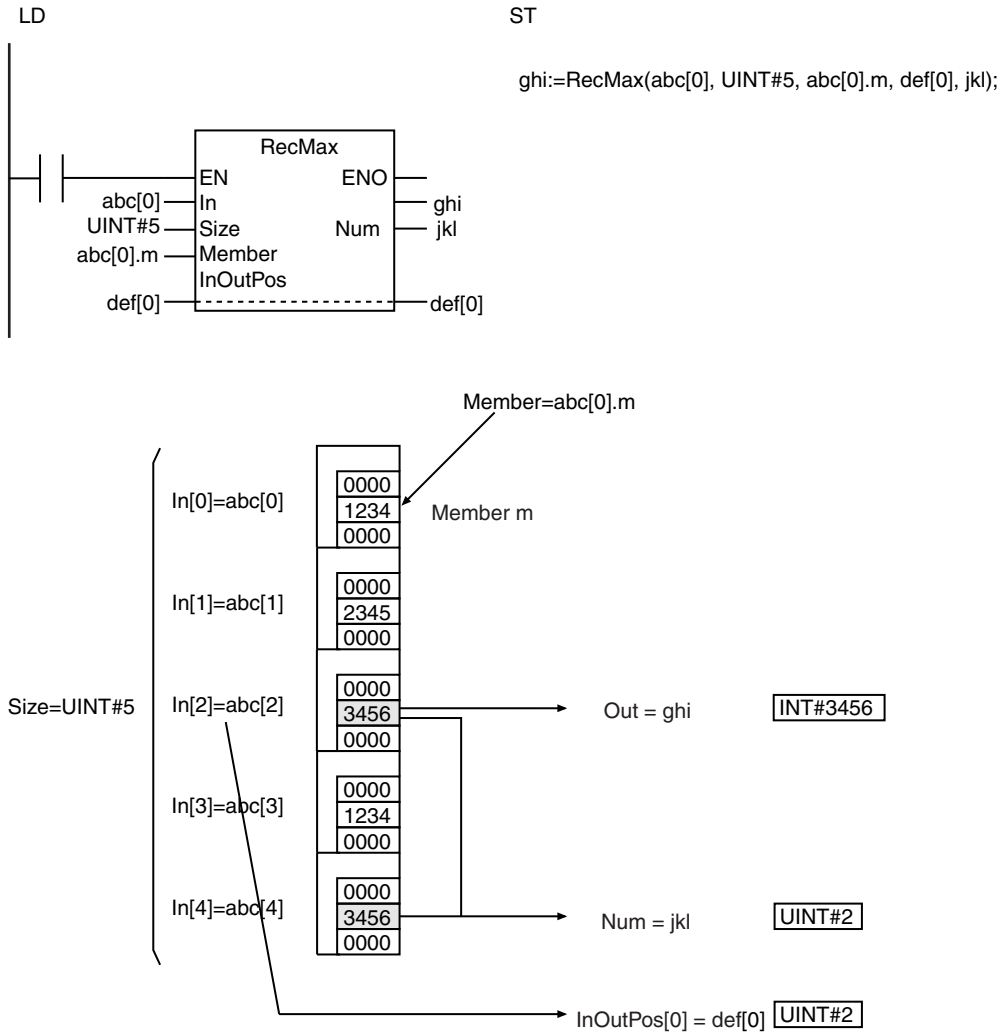

Additional Information

- *In[]* can be a member of a higher-level structure.
Example: In[0]=str0.str1[0]
- *In[]* can be an array with two or more dimensions. If *In[]* is a two-dimensional array, the element number in the first dimension of the element that matches the search conditions is assigned to *InOutPos[0]* and the element number in the second dimension is assigned to *InOutPos[1]*.
- If *In[]* is a three-dimensional array, the element number in the first dimension of the element that matches the search conditions is assigned to *InOutPos[0]*, the element number in the second dimension is assigned to *InOutPos[1]*, and the element number in the third dimension is assigned to *InOutPos[2]*.
- When you search TIME, DT, or TOD data, adjust the data so that the precision of *Member* is the same. Use the following instructions to adjust the precision of the values: TruncTime (page 2-652), TruncDt (page 2-656), and TruncTod (page 2-660).

Precautions for Correct Use

- If you use a different data type for *Member* and *Out*, use only the following data types and make sure the valid range of *Out* includes the valid range of *Member*.
 - USINT, UINT, UDINT, ULINT, SINT, INT, DINT, LINT, REAL, and LREAL
- If *Member* is a real number, depending on the value of *Member*, the desired results may not be achieved due to error.

- When *In* is an enumeration, always use a variable for the input parameter to pass to *In*. A building error will occur if a constant is passed.
- If the value of *Size* is 0, the values of *Out* and *Num* are 0. If *Member* is STRING data and the value of *Size* is 0, *Out* is a text string containing only the NULL character. The values in *InOutPos[]* do not change.
- An error occurs in the following cases. *ENO* will be FALSE, and *Out*, *InOutPos[]*, and *Num* will not change.
 - The value of *Size* exceeds the array area of *In[]*.
 - *Member* is not a member of *In[]*.
 - The array size of *InOutPos[]* is smaller than the number of dimensions of *In[]*.
 - *Member* is STRING data and it does not end in a NULL character.

FCS Instructions

Instruction	Name	Page
StringSum	Checksum Calculation	2-532
StringLRC	Calculate Text String LRC	2-534
StringCRCCCITT	Calculate Text String CRC-CCITT	2-536
StringCRC16	Calculate Text String CRC-16	2-538
AryLRC_**	Calculate Array LRC Group	2-540
AryCRCCCITT	Calculate Array CRC-CCITT	2-542
AryCRC16	Calculate Array CRC-16	2-544

StringSum

The StringSum instruction calculates the checksum for a text string.

Instruction	Name	FB/FUN	Graphic expression	ST expression
StringSum	Checksum Calculation	FUN		Out:=StringSum(In, Size);

Variables

Name	Meaning	I/O	Description	Valid range	Unit	Default
In	Text string to process	Input	Text string to process	Depends on data type.	---	"
Size	Byte size		Byte size of checksum	1 or 2	Bytes	1
Out	Checksum	Output	Checksum	Number of bytes specified by <i>Size</i>	Bytes	---

	Boolean	Bit strings					Integers							Real numbers		Times, durations, dates, and text strings				
	BOOL	BYTE	WORD	DWORD	LWORD	USINT	UINT	UDINT	ULINT	SINT	INT	DINT	LINT	REAL	LREAL	TIME	DATE	TOD	DT	STRING
In																				OK
Size						OK														
Out																				OK

Function

The StringSum instruction calculates the checksum of text string to process *In*. Checksum *Out* will be the number of bytes specified with byte size *Size*. *Out* is given as a hexadecimal text string with a NULL character stored at the end.

The following example is for when *In* is '1234' and *Size* is USINT#2.

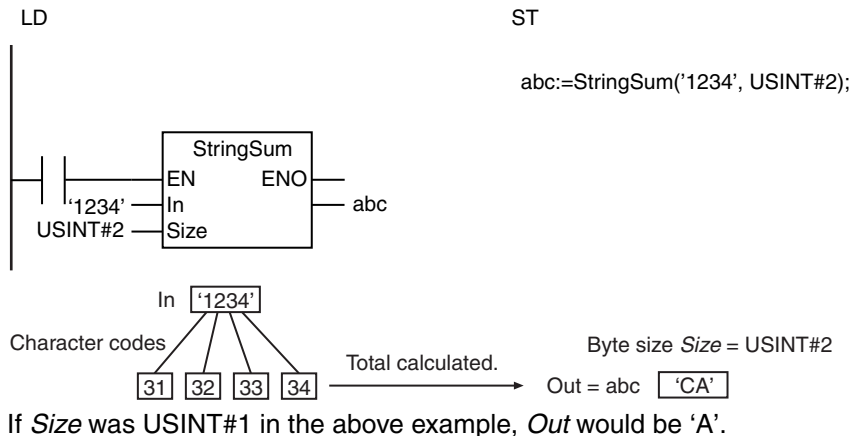

Precautions for Correct Use

- If the sum of the character codes in *In* exceeds the number of digits of *Size*, the upper digits are discarded.
- An error occurs in the following cases. *ENO* will be FALSE, and *Out* will not change.
 - The value of *Size* is outside of the valid range.
 - The number of bytes in *In* is 0 (i.e., the NULL character only).

StringLRC

The StringLRC instruction calculates the LRC value (horizontal parity).

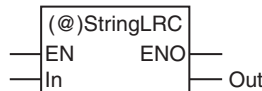
Instruction	Name	FB/FUN	Graphic expression	ST expression
StringLRC	Calculate Text String LRC	FUN		Out:=StringLRC(In);

Variables

Name	Meaning	I/O	Description	Valid range	Unit	Default
In	Text string to process	Input	Text string to process	Depends on data type.	---	"
Out	LRC value	Output	LRC value	3 bytes max. (two single-byte alphanumeric characters plus the final NULL character)	---	---

	Boolean	Bit strings					Integers							Real numbers	Times, durations, dates, and text strings					
	BOOL	BYTE	WORD	DWORD	LWORD	USINT	UINT	UDINT	ULINT	SINT	INT	DINT	LINT	REAL	LREAL	TIME	DATE	TOD	DT	STRING
In																				OK
Out																				OK

Function

The StringLRC instruction calculates the LRC value (horizontal parity) of text string to process *In*. The LRC value is the exclusive logical OR of the character codes for the text string in *In*. The LRC value (*Out*) is given as a hexadecimal text string with a NULL character stored at the end.

The following example is for when *In* is '1234'.

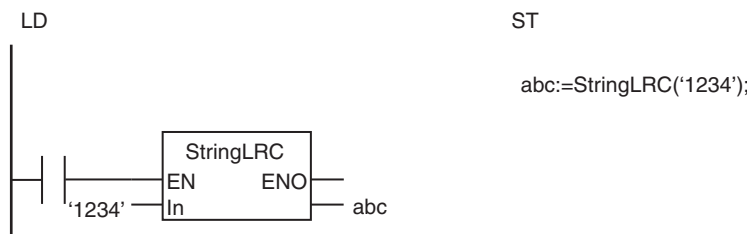

Precautions for Correct Use

An error occurs in the following cases. *ENO* will be FALSE, and *Out* will not change.

- The number of bytes in *In* is 0 (i.e., the NULL character only).

StringCRCCITT

The StringCRCCITT instruction calculates the CRC-CCITT value using the XMODEM method.

Instruction	Name	FB/FUN	Graphic expression	ST expression
StringCRCCITT	Calculate Text String CRC-CCITT	FUN	<pre> graph LR EN --- StringCRCCITT In --- StringCRCCITT Initial --- StringCRCCITT OutOrder --- StringCRCCITT StringCRCCITT --> ENO StringCRCCITT --> Out </pre>	Out:=StringCRCCITT(In, Initial, OutOrder);

Variables

Name	Meaning	I/O	Description	Valid range	Unit	Default
In	Text string to process	Input	Text string to process	Depends on data type.	---	"
Initial	Initial value		Initial value of CRC-CCITT value			0
OutOrder	Byte order		Order to process bytes in <i>In</i>			_LOW_HIGH, _HIGH_LOW
Out	CRC-CCITT value	Output	CRC-CCITT value	5 bytes (four single-byte alphanumeric characters plus the final NULL character)	---	---

	Boolean	Bit strings					Integers							Real numbers		Times, durations, dates, and text strings				
	BOOL	BYTE	WORD	DWORD	LWORD	USINT	UINT	UDINT	ULINT	SINT	INT	DINT	LINT	REAL	LREAL	TIME	DATE	TOD	DT	STRING
In																				OK
Initial			OK																	
OutOrder	Refer to <i>Function</i> for the enumerators of the enumerated type <code>_eBYTE_ORDER</code> .																			
Out																				OK

Function

The StringCRCCITT instruction calculates the CRC-CCITT value of text string to process *In* using the XMODEM method. CRC-CCITT value *Out* is given as a hexadecimal text string with a NULL character stored at the end.

Set *Initial* to the initial value for CRC-CCITT value calculation. *OutOrder* specifies the byte order. The data type of *OutOrder* is enumerated type `_eBYTE_ORDER`. The meanings of the enumerators are as follows:

Enumerators	Meaning
_LOW_HIGH	Lower byte first, upper byte last
_HIGH_LOW	Upper byte first, lower byte last

The following example is for when *In* is 'RD', *Initial* is WORD#16#0000, and *OutOrder* is _HIGH_LOW.

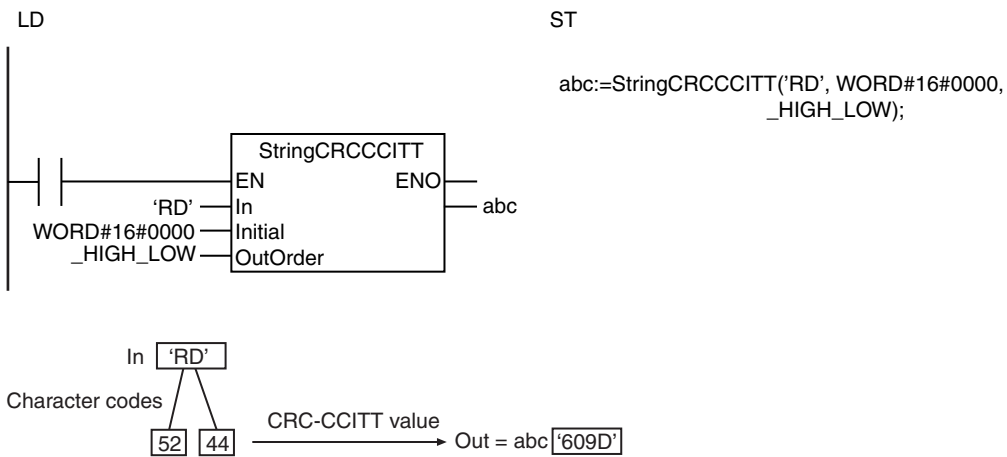

Precautions for Correct Use

An error occurs in the following cases. *ENO* will be FALSE, and *Out* will not change.

- The value of *OutOrder* is outside of the valid range.
- The number of bytes in *In* is 0 (i.e., the NULL character only).

StringCRC16

The StringCRC16 instruction calculates the CRC-16 value using the MODBUS method.

Instruction	Name	FB/FUN	Graphic expression	ST expression
StringCRC16	Calculate Text String CRC-16	FUN	<pre> graph LR EN --- StringCRC16 In --- StringCRC16 Initial --- StringCRC16 OutOrder --- StringCRC16 StringCRC16 --- Out </pre>	Out:=StringCRC16(In, Initial, OutOrder);

Variables

Name	Meaning	I/O	Description	Valid range	Unit	Default
In	Text string to process	Input	Text string to process	Depends on data type.	---	"
Initial	Initial value		Initial value of CRC-16 value			16#FFF F
OutOrder	Byte order		Order to process bytes in <i>In</i>			_LOW_HIGH, _HIGH_LOW
Out	CRC-16 value	Output	CRC-16 value	5 bytes (four single-byte alphanumeric characters plus the final NULL character)	---	---

	Boolean	Bit strings					Integers						Real numbers	Times, durations, dates, and text strings						
	BOOL	BYTE	WORD	DWORD	LWORD	USINT	UINT	UDINT	ULINT	SINT	INT	DINT	LINT	REAL	LREAL	TIME	DATE	TOD	DT	STRING
In																				OK
Initial			OK																	
OutOrder	Refer to <i>Function</i> for the enumerators of the enumerated type <code>_eBYTE_ORDER</code> .																			
Out																				OK

Function

The StringCRC16 instruction calculates the CRC-16 value of text string to process *In* using the MODBUS method. CRC-16 value *Out* is given as a hexadecimal text string with a NULL character stored at the end.

Set *Initial* to the initial value for CRC-16 value calculation. *OutOrder* specifies the byte order.

The data type of *OutOrder* is enumerated type `_eBYTE_ORDER`. The meanings of the enumerators are as follows:

Enumerators	Meaning
_LOW_HIGH	Lower byte first, upper byte last
_HIGH_LOW	Upper byte first, lower byte last

The following example is for when *In* is '01', *Initial* is WORD#16#FFFF and *OutOrder* is _LOW_HIGH.

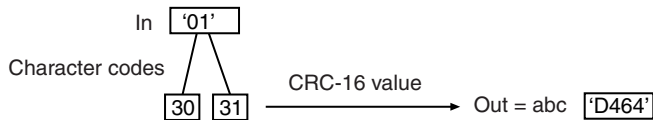
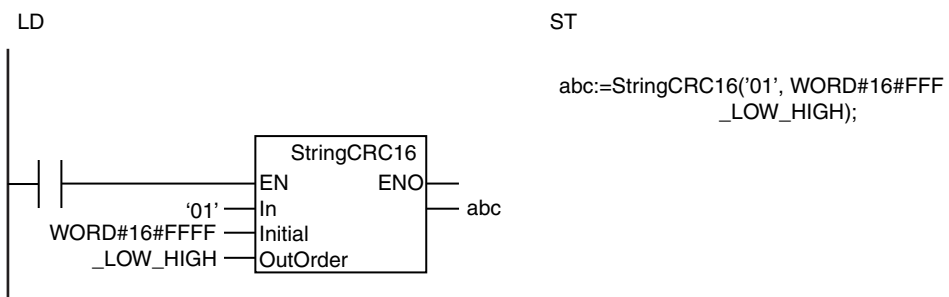

Precautions for Correct Use

An error occurs in the following cases. *ENO* will be FALSE, and *Out* will not change.

- The value of *OutOrder* is outside of the valid range.
- The number of bytes in *In* is 0 (i.e., the NULL character only).

AryLRC_**

The AryLRC_** instructions calculate the LRC value for an array.

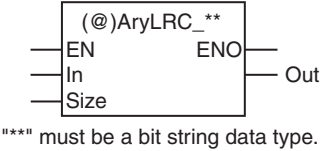
Instruction	Name	FB/FUN	Graphic expression	ST expression
AryLRC_**	Calculate Array LRC Group	FUN		Out:=AryLRC_**(In, Size); "*** must be a bit string data type.

Variables

Name	Meaning	I/O	Description	Valid range	Unit	Default
In[] (array)	Array to process	Input	Array to process	Depends on data type.	---	*
Size	Number of elements to process		Number of In[] elements			1
Out	LRC value	Output	LRC value	Depends on data type.	---	---

* If you omit the input parameter, the default value is not applied. A building error will occur.

	Boolean	Bit strings					Integers							Real numbers	Times, durations, dates, and text strings					
	BOOL	BYTE	WORD	DWORD	LWORD	USINT	UINT	UDINT	ULINT	SINT	INT	DINT	LINT	REAL	LREAL	TIME	DATE	TOD	DT	STRING
In[] (array)		OK	OK	OK	OK															
Size							OK													
Out	Must be same data type as In[]																			

Function

The AryLRC_** instructions calculate the LRC value (exclusive logical OR) of *Size* array elements of array to process *In[]* starting from *In[0]*. The name of the instruction is determined by the data type of *In[]*. For example, if *In[]* is the WORD data type, the instruction is AryLRC_WORD.

Always attach the element number to in-out parameter that is passed to *In[]*, e.g., *array[3]*.

The following example shows the AryLRC_WORD instruction when *Size* is UINT#5.

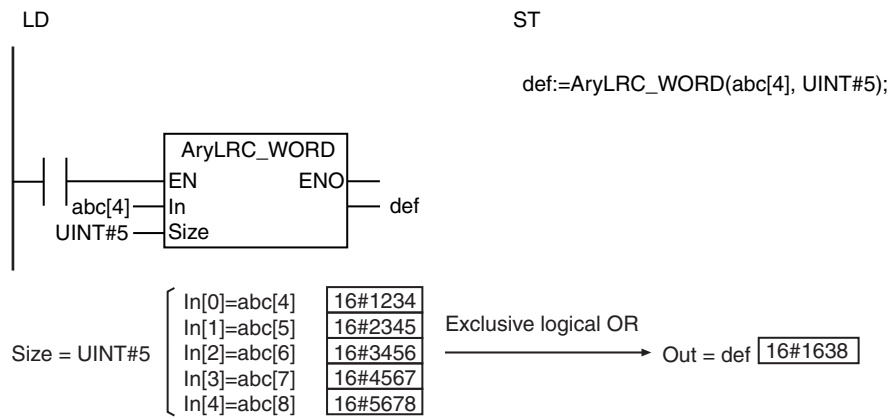

Precautions for Correct Use

- Use the same data type for *In[]* and *Out*.
- If the value of *Size* is 0, the value of *Out* is 16#00.
- An error occurs in the following case. *ENO* will be FALSE, and *Out* will not change.
 - The value of *Size* exceeds the array area of *In[]*.

AryCRCCCITT

The AryCRCCCITT instruction calculates the CRC-CCITT value using the XMODEM method.

Instruction	Name	FB/FUN	Graphic expression	ST expression
AryCRCCCITT	Calculate Array CRC-CCITT	FUN	<pre> graph LR EN --- AryCRCCCITT In --- AryCRCCCITT Size --- AryCRCCCITT Initial --- AryCRCCCITT OutOrder --- AryCRCCCITT AryCRCCCITT --> ENO AryCRCCCITT --> Out </pre>	Out:=AryCRCCCITT(In, Size, Initial, OutOrder);

Variables

Name	Meaning	I/O	Description	Valid range	Unit	Default
In[] (array)	Array to process	Input	Array to process	Depends on data type.	---	*
Size	Number of elements to process		Number of <i>In[]</i> elements			1
Initial	Initial value		Initial value of CRC-CCITT value			0
OutOrder	Byte order		Order to process bytes in <i>In</i>			_LOW_HIGH, _HIGH_LOW
Out	CRC-CCITT value	Output	CRC-CCITT value	Depends on data type.	---	---

* If you omit the input parameter, the default value is not applied. A building error will occur.

	Boolean	Bit strings					Integers							Real numbers	Times, durations, dates, and text strings					
	BOOL	BYTE	WORD	DWORD	LWORD	USINT	UINT	UDINT	ULINT	SINT	INT	DINT	LINT	REAL	LREAL	TIME	DATE	TOD	DT	STRING
In[] (array)		OK	OK	OK	OK	OK	OK	OK	OK	OK	OK	OK	OK	OK	OK	OK	OK	OK	OK	
Size							OK													
Initial			OK																	
OutOrder	Refer to <i>Function</i> for the enumerators for the enumerated type <code>_eBYTE_ORDER</code> .																			
Out			OK																	

Function

The AryCRCCCITT instruction calculates the CRC-CCITT value of *Size* elements of array to process *In[]* starting from *In[0]*. The XMODEM method is used.

Set *Initial* to the initial value for CRC-CCITT value calculation. *OutOrder* specifies the byte order.

The data type of *OutOrder* is enumerated type `_eBYTE_ORDER`. The meaning of the enumerators are as follows:

Enumerators	Meaning
<code>_LOW_HIGH</code>	Lower byte first, upper byte last
<code>_HIGH_LOW</code>	Upper byte first, lower byte last

Always attach the element number to in-out parameter that is passed to *In[]*, e.g., *array[3]*.

The following example is for when *Size* is `UINT#2`, *Initial* is `WORD#16#0000`, and *OutOrder* is `_LOW_HIGH`.

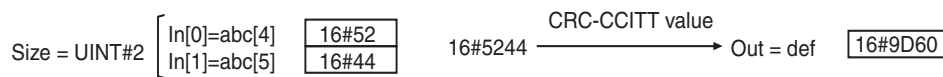
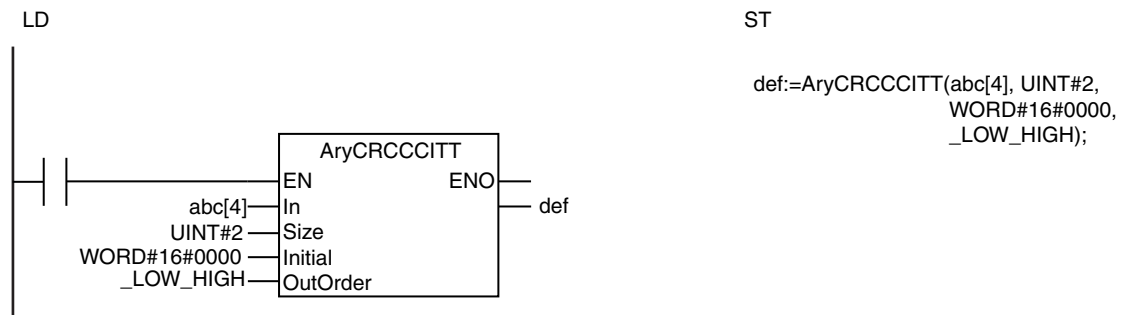

Precautions for Correct Use

- If the value of *Size* is 0, the value of *Out* is `WORD#16#00`.
- An error occurs in the following cases. *ENO* will be `FALSE`, and *Out* will not change.
 - The value of *OutOrder* is outside of the valid range.
 - The value of *Size* exceeds the array area of *In[]*.

AryCRC16

The AryCRC16 instruction calculates the CRC-16 value using the MODBUS method.

Instruction	Name	FB/FUN	Graphic expression	ST expression
AryCRC16	Calculate Array CRC-16	FUN	<pre> graph LR subgraph AryCRC16 [(@)AryCRC16] EN[EN] In[In] Size[Size] Initial[Initial] OutOrder[OutOrder] ENO[ENO] Out[Out] end EN --- AryCRC16 In --- AryCRC16 Size --- AryCRC16 Initial --- AryCRC16 OutOrder --- AryCRC16 AryCRC16 --- ENO AryCRC16 --- Out </pre>	Out:=AryCRC16(In, Size, Initial, OutOrder);

Variables

Name	Meaning	I/O	Description	Valid range	Unit	Default
In[] (array)	Array to process	Input	Array to process	Depends on data type.	---	*
Size	Number of elements to process		Number of <i>In[]</i> elements			1
Initial	Initial value		Initial value of CRC-16 value			16#FFF F
OutOrder	Byte order		Order to process bytes in <i>In</i>			_LOW_HIGH, _HIGH_LOW
Out	CRC-16 value	Output	CRC-16 value	Depends on data type.	---	---

* If you omit the input parameter, the default value is not applied. A building error will occur.

	Boolean	Bit strings					Integers							Real numbers		Times, durations, dates, and text strings				
	BOOL	BYTE	WORD	DWORD	LWORD	USINT	UINT	UDINT	ULINT	SINT	INT	DINT	LINT	REAL	LREAL	TIME	DATE	TOD	DT	STRING
In[] (array)		OK	OK	OK	OK	OK	OK	OK	OK	OK	OK	OK	OK	OK	OK	OK	OK	OK	OK	
Size							OK													
Initial			OK																	
OutOrder	Refer to <i>Function</i> for the enumerators for the enumerated type <code>_eBYTE_ORDER</code> .																			
Out			OK																	

Function

The AryCRC16 instruction calculates the CRC-16 value of *Size* array elements of array to process *In[]* starting from *In[0]*. The MODBUS method is used.

Set *Initial* to the initial value for CRC-16 value calculation. *OutOrder* specifies the byte order.

The data type of *OutOrder* is enumerated type *_eBYTE_ORDER*. The meaning of the enumerators are as follows:

Enumerator	Meaning
<i>_LOW_HIGH</i>	Lower byte first, upper byte last
<i>_HIGH_LOW</i>	Upper byte first, lower byte last

Always attach the element numbers to the input parameter that is passed to *In[]*, e.g., *array[3]*.

The following example is for when *Size* is *UINT#2*, *Initial* is *WORD#16#FFFF* and *OutOrder* is *_LOW_HIGH*.

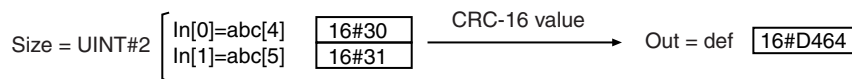
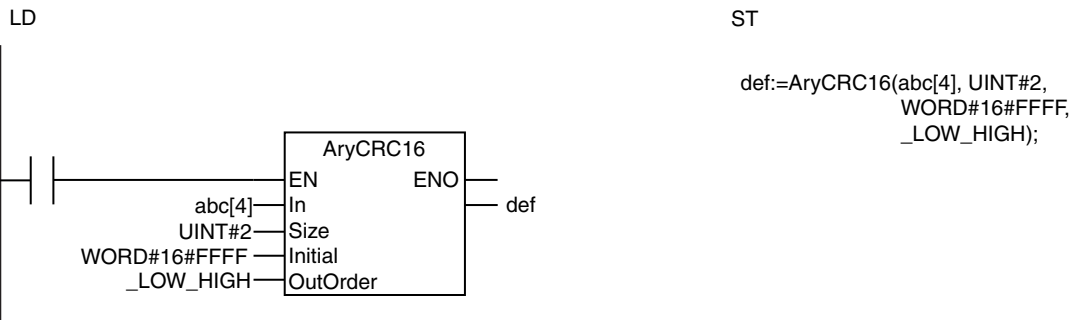

Precautions for Correct Use

- If the value of *Size* is 0, the value of *Out* is *WORD#16#0*.
- An error occurs in the following cases. *ENO* will be *FALSE*, and *Out* will not change.
 - The value of *OutOrder* is outside of the valid range.
 - The value of *Size* exceeds the array area of *In[]*.

Text String Instructions

Instruction	Name	Page
CONCAT	Concatenate String	2-548
LEFT and RIGHT	Get String Left/Get String Right	2-550
MID	Get String Any	2-552
FIND	Find String	2-554
LEN	String Length	2-556
REPLACE	Replace String	2-557
DELETE	Delete String	2-559
INSERT	Insert String	2-561
GetByteLen	Get Byte Length	2-563
ClearString	Clear String	2-565
ToUCase and ToLCase	Convert to Uppercase/ Convert to Lowercase	2-567
TrimL and TrimR	Trim String Left/Trim String Right	2-569
AddDelimiter	Put Text Strings with Delimiters	2-571
SubDelimiter	Get Text Strings Minus Delimiters	2-582

CONCAT

The CONCAT instruction joins two to five text strings.

Instruction	Name	FB/FUN	Graphic expression	ST expression
CONCAT	Concatenate String	FUN		Out:=CONCAT(In1,..., InN);

Variables

Name	Meaning	I/O	Description	Valid range	Unit	Default
In1 to InN	Strings to join	Input	Text strings to join, where N is 2 to 5	Depends on data type.	---	**
Out	Result of joining	Output	Text string that resulted from joining	Depends on data type.	---	---

* If you omit the input parameter that connects to *InN*, the default value is not applied, and a building error will occur. For example, if N is 3 and the input parameters that connect to *In1* and *In2* are omitted, the default values are applied, but if the input parameter that connects to *In3* is omitted, a building error will occur.

	Boolean	Bit strings					Integers							Real numbers		Times, durations, dates, and text strings				
	BOOL	BYTE	WORD	DWORD	LWORD	USINT	UINT	UDINT	ULINT	SINT	INT	DINT	LINT	REAL	LREAL	TIME	DATE	TOD	DT	STRING
In1 to InN																				OK
Out																				OK

Function

The CONCAT instruction joins 2 to 5 text strings in strings to join *In1* to *InN* in that order. It adds a NULL character to the end.

The following example is for when *In1* is 'AB', *In2* is 'C' and *In3* is 'DEF'. The value of variable *abc* will be 'ABCDEF'.

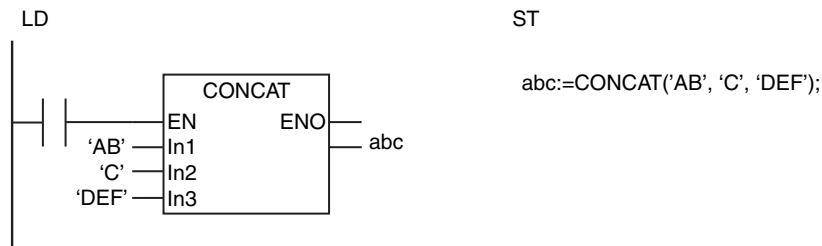

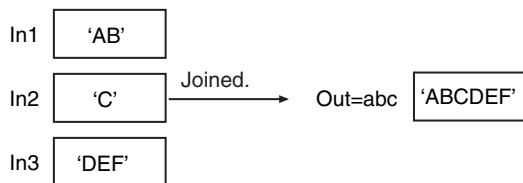

Precautions for Correct Use

An error occurs in the following cases. *ENO* will be FALSE, and *Out* will not change.

- The length of the joined character strings exceeds 1,986 bytes.

LEFT and RIGHT

These instructions extract a text string with the specified number of characters.

LEFT: Extracts characters from the left (beginning) of the text string.

RIGHT: Extracts characters from the right (end) of the text string.

Instruction	Name	FB/FUN	Graphic expression	ST expression
LEFT	Get String Left	FUN		Out:=LEFT(In, L);
RIGHT	Get String Right	FUN		Out:=RIGHT(In, L);

Variables

Name	Meaning	I/O	Description	Valid range	Unit	Default
In	Source string	Input	Text string from which to extract characters	Depends on data type.		"
L	Number of characters		Number of characters to extract	0 to 1985	---	1
Out	Extraction result	Output	Extracted text string	Depends on data type.	---	---

	Boolean	Bit strings					Integers							Real numbers		Times, durations, dates, and text strings				
	BOOL	BYTE	WORD	DWORD	LWORD	USINT	UINT	UDINT	ULINT	SINT	INT	DINT	LINT	REAL	LREAL	TIME	DATE	TOD	DT	STRING
In																				OK
L							OK													
Out																				OK

Function

These instructions extract a text string with the number of characters specified by number of characters *L* from the source string *In*. A NULL character is placed at the end of extraction result *Out*.

● LEFT

Extracts characters from the left (beginning) of *In*.

MID

The MID instruction extracts a text string with the specified number of characters from the specified character position.

Instruction	Name	FB/FUN	Graphic expression	ST expression
MID	Get String Any	FUN		Out:=MID(In, L, P);

Variables

Name	Meaning	I/O	Description	Valid range	Unit	Default
In	Source string	Input	Text string from which to extract characters	Depends on data type.	---	"
L	Number of characters		Number of characters to extract	0 to 1985		
P	First character		First character to extract	1 to 1985		
Out	Extraction result	Output	Extracted text string	Depends on data type.	---	---

	Boolean	Bit strings					Integers							Real numbers	Times, durations, dates, and text strings					
	BOOL	BYTE	WORD	DWORD	LWORD	USINT	UINT	UDINT	ULINT	SINT	INT	DINT	LINT	REAL	LREAL	TIME	DATE	TOD	DT	STRING
In																				OK
L							OK													
P							OK													
Out																				OK

Function

The MID instruction extracts a text string with the number of characters specified by number of characters *L* from the source string *In*. The first character to extract is specified by first character *P*. A NULL character is placed at the end of extraction result *Out*.

The following example is for when *In* is 'ABCDEF', *L* is UINT#3, and *P* is UINT#2. The value of variable *abc* will be 'BCD'.

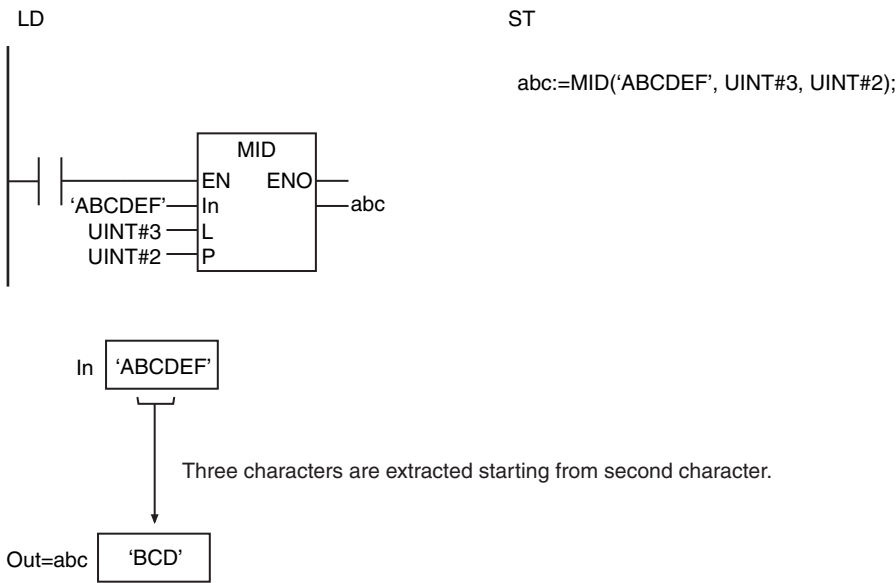

Precautions for Correct Use

- If the value of *L* is 0, an error does not occur and only the NULL character is assigned to *Out*.
- Multi-byte characters are counted as one character each.
- An error occurs in the following cases. *ENO* will be FALSE, and *Out* will not change.
 - *In* results in a character code error.
 - *In* does not have enough characters for the number of characters specified by *L* from the position specified by *P*.
 - The value of *P* is 0.

FIND

The FIND instruction searches a specified text string for the position of a specified text string.

Instruction	Name	FB/FUN	Graphic expression	ST expression
FIND	Find String	FUN		Out:=FIND(In1, In2);

Variables

Name	Meaning	I/O	Description	Valid range	Unit	Default
In1	String to search	Input	Text string to search	Depends on data type.	---	"
In2	Search key		Text string to search for			
Out	Search result	Output	Search result	0 to 1985	---	---

	Boolean	Bit strings					Integers							Real numbers	Times, durations, dates, and text strings					
	BOOL	BYTE	WORD	DWORD	LWORD	USINT	UINT	UDINT	ULINT	SINT	INT	DINT	LINT	REAL	LREAL	TIME	DATE	TOD	DT	STRING
In1																				OK
In2																				OK
Out							OK													

Function

The FIND instruction searches for search key *In2* in string to search *In1*. The position of *In2* from the start of *In1* is assigned to search result *Out*. If *In2* is not found in *In1*, *Out* is 0.

The following example is for when *In1* is 'ABCDEF' and *In2* is 'CD'. The value of variable *abc* will be UINT#3.

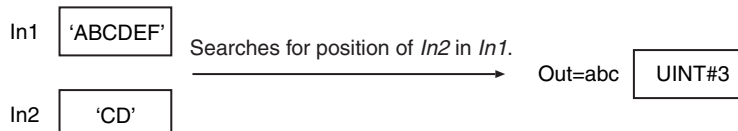
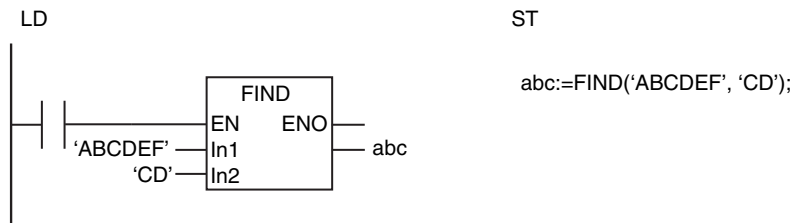

Precautions for Correct Use

- Make sure the number of characters in *In2* is less than the number of characters in *In1*. Otherwise, the value of *Out* will be 0.
- If *In2* exists more than once in *In1*, the position of the first *In2* from the beginning of *In1* is assigned to *Out*.
- If the value of *In1* and *In2* is only the NULL character, the value of *Out* is 1.
- Multi-byte characters are counted as one character each.
- An error occurs in the following cases. *ENO* will be FALSE, and *Out* will not change.
 - *In1* or *In2* results in a character code error.

LEN

The LEN instruction finds the number of characters in a text string.

Instruction	Name	FB/FUN	Graphic expression	ST expression
LEN	String Length	FUN		Out:=LEN(In);

Variables

Name	Meaning	I/O	Description	Valid range	Unit	Default
In	Length string	Input	Text string to find length	Depends on data type.	---	"
Out	Find result	Output	Length detection result	0 to 1985	---	---

	Boolean	Bit strings					Integers							Real numbers		Times, durations, dates, and text strings					
		BOOL	BYTE	WORD	DWORD	LWORD	USINT	UINT	UDINT	ULINT	SINT	INT	DINT	LINT	REAL	LREAL	TIME	DATE	TOD	DT	STRING
In																					OK
Out							OK														

Function

The LEN instruction finds the number of characters in length string *In*. A NULL character at the end of *In* is not counted.

The following example is for when *In* is 'ABCDEF'. The value of variable *abc* will be UINT#6.

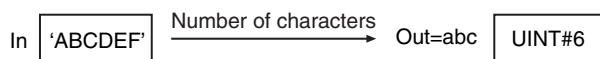
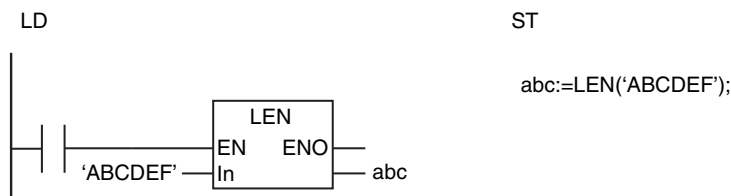

Precautions for Correct Use

- Multi-byte characters are counted as one character each.
- An error occurs in the following cases. *ENO* will be FALSE, and *Out* will not change.
 - *In* results in a character code error.

REPLACE

The REPLACE instruction replaces part of a text string with another text string.

Instruction	Name	FB/FUN	Graphic expression	ST expression
REPLACE	Replace String	FUN		Out:=REPLACE(In1, In2, L, P);

Variables

Name	Meaning	I/O	Description	Valid range	Unit	Default
In1	String for replacement	Input	Text string for replacement	Depends on data type.	---	"
In2	Insert string		Text string to insert			
L	Number of characters		Number of characters to delete	0 to 1985		
P	Replacement start position		Replacement start position	1 to 1985		1
Out	Replacement result	Output	Text string after replacement	Depends on data type.	---	---

	Boolean	Bit strings				Integers							Real numbers		Times, durations, dates, and text strings					
	BOOL	BYTE	WORD	DWORD	LWORD	USINT	UINT	UDINT	ULINT	SINT	INT	DINT	LINT	REAL	LREAL	TIME	DATE	TOD	DT	STRING
In1																				OK
In2																				OK
L							OK													
P							OK													
Out																				OK

Function

The REPLACE instruction replaces part of string for replacement *In1* with string to insert *In2*. First the number of characters specified by *L* from the position specified by *P* are deleted from *In1*. *In2* is then inserted for the deleted characters. A NULL character is placed at the end of replacement result *Out*.

The following example is for when *In1* is 'ABCDEF', *In2* is 'GHI', *P* is UINT#2, and *L* is UINT#4. The value of variable *abc* will be 'AGHIF'.

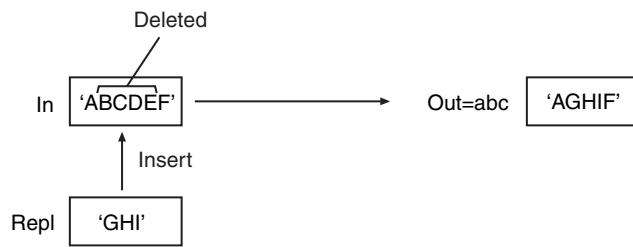
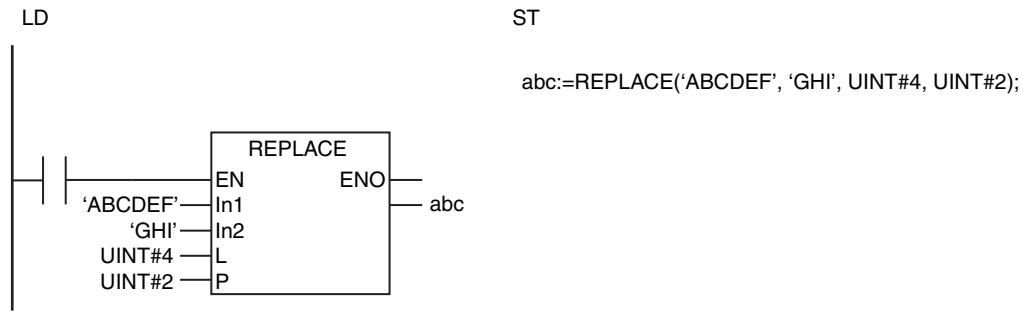

Precautions for Correct Use

- If *L* is 0, an error will not occur and all of the characters in *In1* are inserted to *Out*.
- If the value of *In2* is 0, *L* characters are deleted from *P* in *In1*.
- Multi-byte characters are counted as one character each.
- An error occurs in the following cases. *ENO* will be FALSE, and *Out* will not change.
 - *In1* results in a character code error.
 - *In1* does not have enough characters for the number of characters specified by *L* from the position specified by *P*.
 - The value of *P* is 0.
 - The length of the character string after the replacement exceeds 1,986 bytes.

DELETE

The DELETE instruction deletes all or part of a text string.

Instruction	Name	FB/FUN	Graphic expression	ST expression
DELETE	Delete String	FUN		Out:=DELETE(In, L, P);

Variables

Name	Meaning	I/O	Description	Valid range	Unit	Default
In	String for deletion	Input	Text string for deletion	Depends on data type.	---	"
L	Number of characters		Number of characters to delete	0 to 1985		1
P	Deletion start position		Deletion start position	1 to 1985		
Out	Deletion result	Output	Text string after deletion	Depends on data type.	---	---

	Boolean	Bit strings				Integers							Real numbers	Times, durations, dates, and text strings						
	BOOL	BYTE	WORD	DWORD	LWORD	USINT	UINT	UDINT	ULINT	SINT	INT	DINT	LINT	REAL	LREAL	TIME	DATE	TOD	DT	STRING
In																				OK
L							OK													
P							OK													
Out																				OK

Function

The DELETE string deletes the number of characters specified by *L* from the position specified by *P* from *In*. A NULL character is placed at the end of deletion result *Out*.

The following example is for when *In* is 'ABCDEF', *L* is UINT#4, and *P* is UINT#2. The value of variable *abc* will be 'AF'.

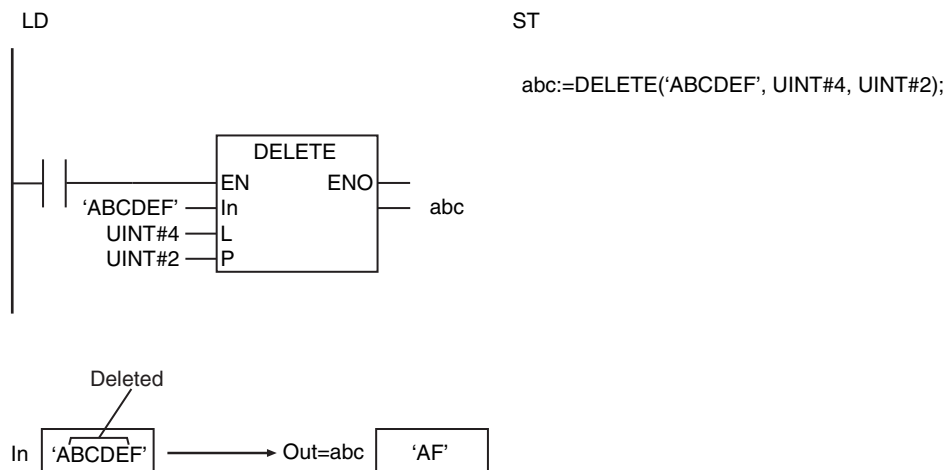

Precautions for Correct Use

- If *L* is 0, an error will not occur and all of the characters in *In* are inserted to *Out*.
- Multi-byte characters are counted as one character each.
- An error occurs in the following cases. *ENO* will be FALSE, and *Out* will not change.
 - *In* results in a character code error.
 - *In* does not have enough characters for the number of characters specified by *L* from the position specified by *P*.
 - The value of *P* is 0.

INSERT

The INSERT instruction inserts a text string into another text string.

Instruction	Name	FB/FUN	Graphic expression	ST expression
INSERT	Insert String	FUN		Out:=INSERT(In1, In2, P);

Variables

Name	Meaning	I/O	Description	Valid range	Unit	Default
In1	Original string	Input	Text string into which to insert string	Depends on data type.	---	"
In2	Insert string		Text string to insert			
P	Insertion start position		Insertion start position	0 to 1985		
Out	Insertion result	Output	Text string after insertion	Depends on data type.	---	---

	Boolean	Bit strings				Integers							Real numbers		Times, durations, dates, and text strings					
	BOOL	BYTE	WORD	DWORD	LWORD	USINT	UINT	UDINT	ULINT	SINT	INT	DINT	LINT	REAL	LREAL	TIME	DATE	TOD	DT	STRING
In1																				OK
In2																				OK
P							OK													
Out																				OK

Function

The INSERT instruction inserts insertion string *In2* into original string *In1* at insertion start position *P*. A NULL character is placed at the end of insertion result *Out*.

The following example is for when *In1* is 'ABCD', *In2* is 'GHI', and *P* is UINT#2. The value of variable *abc* will be 'ABGHICD'.

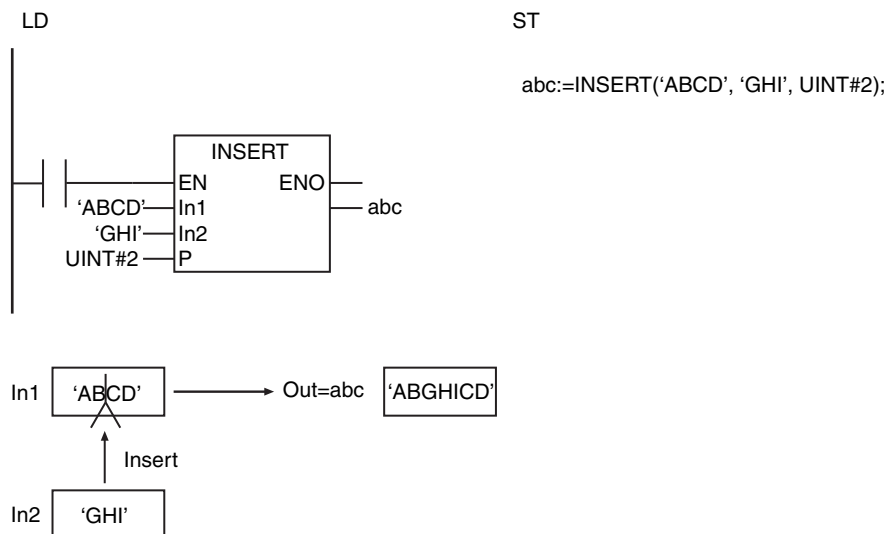

Additional Information

If *P* is 0, *In1* is inserted at the end of *In2*.

Precautions for Correct Use

- Multi-byte characters are counted as one character each.
- An error occurs in the following cases. *ENO* will be FALSE, and *Out* will not change.
 - *In1* results in a character code error.
 - The value of *P* is greater than the number of characters in *In1*.
 - The length of the character string after the insertion exceeds 1,986 bytes.

GetByteLen

The GetByteLen instruction counts the number of bytes in a text string.

Instruction	Name	FB/FUN	Graphic expression	ST expression
GetByteLen	Get Byte Length	FUN		Out:=GetByteLen(In);

Variables

Name	Meaning	I/O	Description	Valid range	Unit	Default
In	Count string	Input	Text string to count number of bytes	Depends on data type.	---	"
Out	Number of bytes	Output	Number of bytes	0 to 1985	Bytes	---

	Boolean	Bit strings				Integers							Real numbers	Times, durations, dates, and text strings						
	BOOL	BYTE	WORD	DWORD	LWORD	USINT	UINT	UDINT	ULINT	SINT	INT	DINT	LINT	REAL	LREAL	TIME	DATE	TOD	DT	STRING
In																				OK
Out							OK													

Function

The GetByteLen instruction counts the number of bytes in count string *In*. A NULL character at the end of the text string is not counted.

The following example is for when *In* is 'ABCDEF'. The value of variable *abc* will be 6.

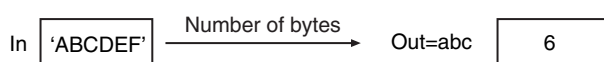
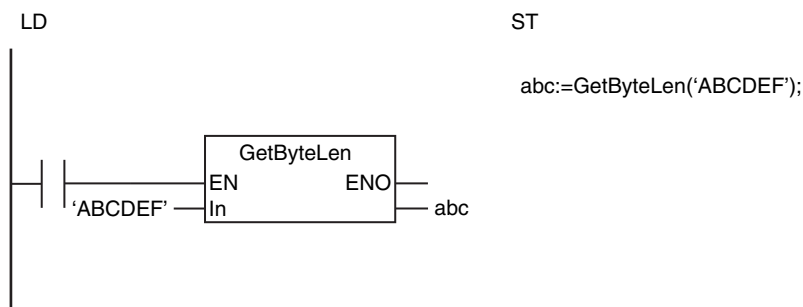

Additional Information

If *ln* contains only ASCII characters, the result will be the same as the result of the LEN instruction.

Precautions for Correct Use

Return value *Out* is not used when the instruction is used in ST.

ToUCase and ToLCase

ToUCase: Converts all single-byte letters in a text string to uppercase.

ToLCase: Converts all single-byte letters in a text string to lowercase.

Instruction	Name	FB/FUN	Graphic expression	ST expression
ToUCase	Convert to Uppercase	FUN		Out:=ToUCase(In);
ToLCase	Convert to Lowercase	FUN		Out:=ToLCase(In);

Variables

Name	Meaning	I/O	Description	Valid range	Unit	Default
In	Data to convert	Input	Text string to convert	Depends on data type.	---	"
Out	Conversion result	Output	Converted text string	Depends on data type.	---	---

	Boolean	Bit strings				Integers							Real numbers		Times, durations, dates, and text strings					
	BOOL	BYTE	WORD	DWORD	LWORD	USINT	UINT	UDINT	ULINT	SINT	INT	DINT	LINT	REAL	LREAL	TIME	DATE	TOD	DT	STRING
In																				OK
Out																				OK

Function

● ToUCase

The ToUCase instruction converts all single-byte letters in data to convert *In* to uppercase.

● ToLCase

The ToLCase instruction converts all single-byte letters in data to convert *In* to lowercase.

Both instructions output a NULL character at the end of the text string. Only single-byte characters are changed.

The following example for the ToUCase instruction is for when *In* is 'xyz'. The value of variable *abc* will be 'XYZ'.

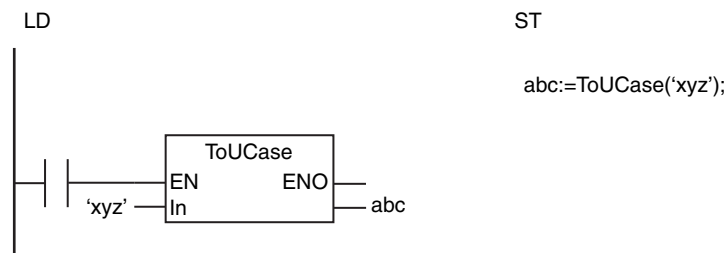

The ToUCase instruction converts all single-byte letters in *In* to uppercase.

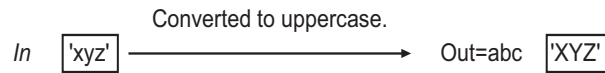

Precautions for Correct Use

- Two-byte letters are not converted.
- An error occurs in the following cases. *ENO* will be FALSE, and *Out* will not change.
 - *In* results in a character code error.

TrimL and TrimR

TrimL: Removes blank space from the beginning of a text string.

TrimR: Removes blank space from the end of a text string.

Instruction	Name	FB/FUN	Graphic expression	ST expression
TrimL	Trim String Left	FUN		Out:=TrimL(In);
TrimR	Trim String Right	FUN		Out:=TrimR(In);

Variables

Name	Meaning	I/O	Description	Valid range	Unit	Default
In	String to trim	Input	Text string to trim	Depends on data type.	---	"
Out	Trimming result	Output	Text string after trimming	Depends on data type.	---	---

	Boolean	Bit strings				Integers							Real numbers		Times, durations, dates, and text strings					
	BOOL	BYTE	WORD	DWORD	LWORD	USINT	UINT	UDINT	ULINT	SINT	INT	DINT	LINT	REAL	LREAL	TIME	DATE	TOD	DT	STRING
In																				OK
Out																				OK

Function

● TrimL

The TrimL instruction deletes blank characters from the beginning of string to trim *In*. If there are no blank characters at the beginning of the text string, nothing is done.

● TrimR

The TrimR instruction deletes blank characters from the end of string to trim *In*. If there are no blank characters at the end of the text string, nothing is done.

Both instructions output a NULL character at the end of the text string. Both ASCII spaces (16#20) and two-byte Japanese spaces (16#E38080) are treated as blank characters.

The following example for the TrimL instruction is for when *In* is ' AB C'. The value of variable *abc* will be ' AB C'.

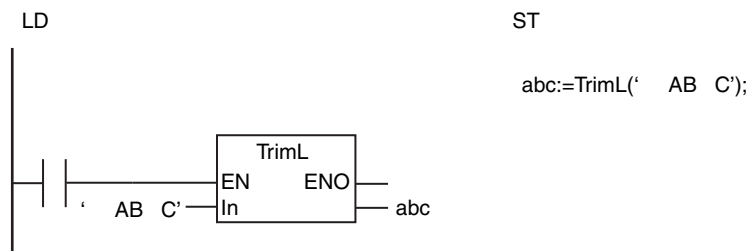

The TrimL instruction deletes blank characters from the beginning of *In*.

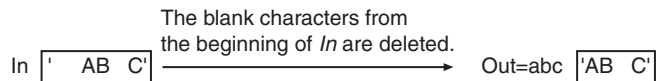

Precautions for Correct Use

An error occurs in the following cases. *ENO* will be FALSE, and *Out* will not change.

- *In* results in a character code error.

AddDelimiter

The AddDelimiter instruction converts the values in a structure to text strings and adds delimiters.

Instruction	Name	FB/FUN	Graphic expression	ST expression
AddDelimiter	Put Text Strings with Delimiters	FUN		Out:=AddDelimiter(In,Delimiter);

Variables

Name	Meaning	I/O	Description	Valid range	Unit	Default
In	Input structure	Input	Structure to convert to text strings	Depends on data type of members.	---	*
Delimiter	Delimiter		Delimiter	_COMMA _TAB _SEMICOLON _SPACE	---	_COMMA
Out	Return value	Output	Text strings with delimiters	1,986 bytes max. (1,985 single-byte alphanumeric characters plus the final NULL character)	---	---

* If you omit the input parameter, the default value is not applied. A building error will occur.

	Boolean	Bit strings				Integers							Real numbers	Times, durations, dates, and text strings						
	BOOL	BYTE	WORD	DWORD	LWORD	USINT	UINT	UDINT	ULINT	SINT	INT	DINT	LINT	REAL	LREAL	TIME	DATE	TOD	DT	STRING
In																				
Delimiter																				
Out																				OK

Function

The AddDelimiter instruction starts from the beginning of input structure *In* and converts the values of the members to text strings, which it separates with delimiter *Delimiter* and then concatenates. The concatenated text string is output to return value *Out*. A NULL character is placed at the end of *Out*.

The data type of *Delimiter* is enumerated type `_eDELIMITER`. The meanings of the enumerators are as follows:

Enumerator	Meaning
_COMMA	',' (comma)
_TAB	'\$T' (tab)
_SEMICOLON	',' (semicolon)
_SPACE	' ' (blank character)

The values of the members of *In* are converted according to their data type, as described next.

● **Boolean Data**

FALSE is converted to '0' and TRUE is converted to '1'.

● **Bit String Data**

Bits strings are treated as hexadecimal numbers and converted to text strings that express them as alphanumeric characters. The 16# prefix of the hexadecimal number is not output to the text string.

If the value of the member requires fewer digits than are provided by the data type of the member, the upper digits will contain '0'. In other words, the unused digits are padded with zeros.

The number of characters in the text string depends on the data type as shown in the following table.

Data type of member	Number of characters
BYTE	2 single-byte alphanumeric characters
WORD	4 single-byte alphanumeric characters
DWORD	8 single-byte alphanumeric characters
LWORD	16 single-byte alphanumeric characters

Examples are given below.

Value of member	Converted text string
BYTE#16#AB	'AB'
LWORD#16#0123	'0000000000000123'

● **Integer Data**

The value of the integer is converted to a text string. Upper digits that are 0 are not output to the text string. If the value of the member is negative, a minus sign (-) is added to the front of the text string. Examples are given below.

Value of member	Converted text string
UINT#0012	'12'
LINT#-12	'-12'

● **Real Number Data**

The structure of the text string to which the value of the member is converted is shown below.

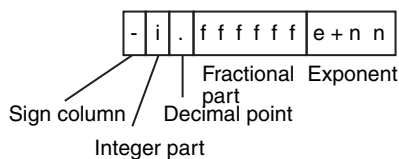

Item	Description
Sign column	If the value of the member is negative, a minus sign (-) is added. If the value of the member is positive, a plus sign (+) is not added.
Integer part	The integer part is always only one digit.
Decimal point	The decimal point is always given even if the value of the member is not a decimal number.
Fractional part	If the member is REAL data, 6 digits are given. If the member is LREAL data, 14 digits are given.
Exponent	The exponent is always given. 'e' indicates the exponent e. "nn" is 2 or 3 digits. The sign of "nn" is positive (+) if the absolute value of the member is 1.0 or higher and negative (-) if it is less than 1.0. If the value of the member is 0, this portion is '+'(positive).

If the value of the member is infinity, or nonnumeric data, the text string will be as shown below.

Value of member	Text string
+∞	'inf'
-∞	'-inf'
Nonnumeric data	'nan' or '-nan'

Examples are given below.

Value of member	Converted text string
REAL#3.14e1	'3.140000e+01'
REAL#-123.4567	'-1.234567e+02'
REAL#0	'0.000000e+00'
LREAL#0.00123456789	'1.23456789000000e-03'
LREAL#1.0e308	'1.00000000000000e+308'

● **Duration Data**

The structure of the text string to which the value of the member is converted is shown below.

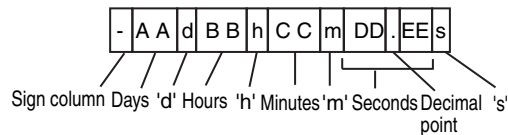

Item	Description
Sign column	If the value of the member is negative, a minus sign (-) is added. If the value of the member is positive, a plus sign (+) is not added.
Days	The number of days is always given. The range of the value is 0 to 106751. Upper digits are not padded with 0.
Hours	The number of hours is always given in two digits. The range of the value is 00 to 23.
Minutes	The number of minutes is always given in two digits. The range of the value is 00 to 59.
Seconds	The number of seconds is always given. The value of DD is always given in two digits between 00 and 59. The value of EE is always given in two digits between 00000000 and 99999999
'd', 'h', 'm', 's', and the decimal point	These are always given.

Examples are given below.

Value of member	Converted text string
T#-180122000ms	'-2d02h02m02.000000000s'
T#100d2h3m5.678s	'100d02h03m05.678000000s'
T#2h3m5.678s	'0d02h03m05.678000000s'

● **Date Data**

The structure of the text string to which the value of the member is converted is shown below.

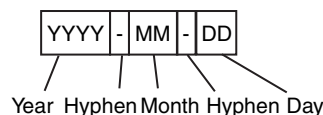

The month and day are converted to two digits each and output to the text string.

An example is shown below.

Value of member	Converted text string
D#2010-1-2	'2010-01-02'

● **Date and Time Data**

The structure of the text string to which the value of the member is converted is shown below.

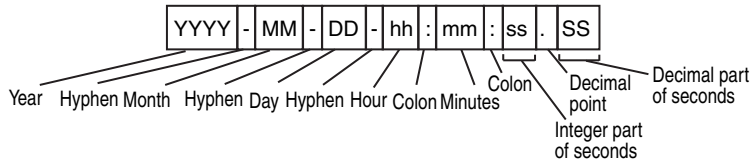

The month (MM), day (DD), hour (hh), minutes (mm), and integer part of the seconds (ss) are converted to two digits each and output to the text string. The fractional part of the seconds (ss) is converted to nine digits and output to the text string.

An example is shown below.

Value of member	Converted text string
DT#2004-09-23-12:16:8.12	'2004-09-23-12:16:08.120000000'

● **Time of Day Data**

The structure of the text string to which the value of the member is converted is shown below.

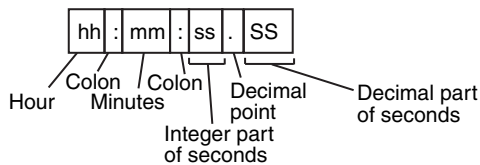

The hour (hh), minutes (mm), and integer part of the seconds (ss) are converted to two digits each and output to the text string. The fractional part of the seconds (ss) is converted to nine digits and output to the text string.

An example is shown below.

Value of member	Converted text string
TOD#2:16:28.12	'02:16:28.120000000'

● **Text String Data**

The text string is output without any changes. The NULL character at the end of the text string is not included. For example, if the value of the member is 'ABC' and includes a NULL character at the end, 'ABC' without the NULL character is output to the text string.

● **Structure Data**

The values of the members are converted in order from the start of the structure down to the nesting levels that are not structures. The values of the members are converted to text strings according to the rules for their data types. For example, if a member of structure A has a data type of Structure_B, the conversion works as shown below. Commas are used as delimiters in this example.

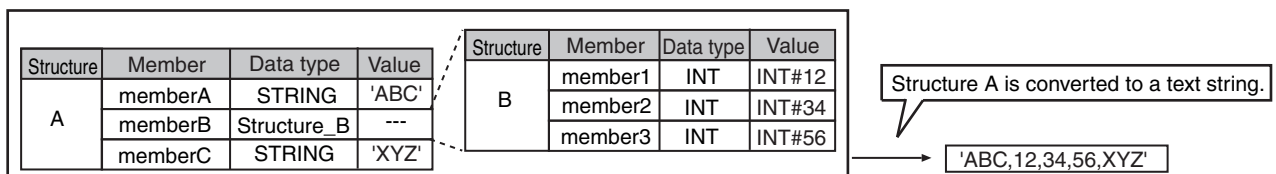

● **Enumeration Data**

The value of the enumeration is treated as DINT data and converted accordingly.

For example, assume that an enumeration *Color* has three enumerators: *red*, *yellow*, and *green*. The numbers associated with these enumerators are as follows: *red* = 1, *yellow* = 2, *green* = 3. If the value of a member of enumeration *Color* is *yellow*, the text string will be '2'.

● Array Data

The text strings for the elements of the array are separated with the delimiter. The value of each element is converted according to the conversion rules for the data type of the array. Only one-dimensional arrays are converted.

For example, take the INT array *myArray[0..2]*. If the value of *myArray[0]* is INT#225, the value of *myArray[1]* is INT#-128, the value of *myArray[2]* is INT#0, and the delimiter is a comma, the text string would be as follows: '225,-128,0'.

Notation Example

The following notation is used to convert the myStruct structure to the myString text string. The ',' (comma) is the delimiter.

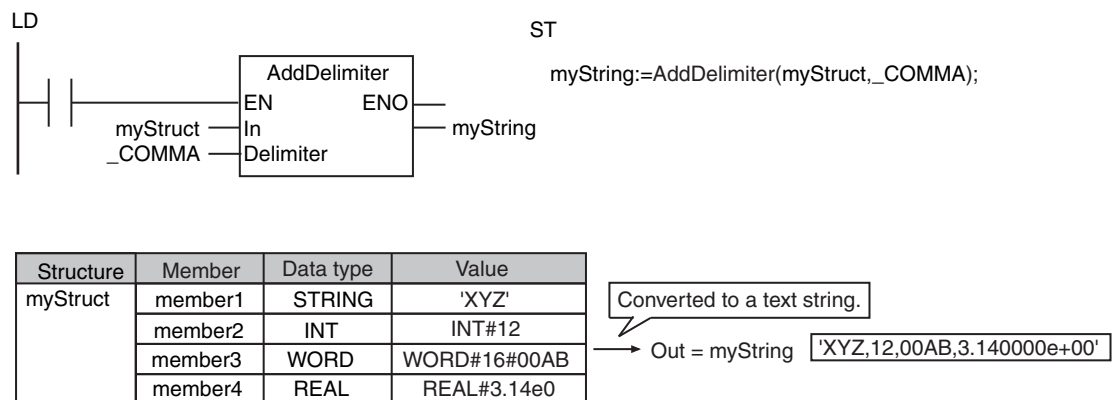

Additional Information

- You can combine this instruction with the *FilePuts instruction* (page 2-1383) to easily write values to specified CSV files in an SD Memory Card. Refer to *Sample Programming* for an application example.
- You can use the *SubDelimiter instruction* (page 2-582) to read text strings that were converted with the AddDelimiter instruction and output them as the values of the members of a structure.

Precautions for Correct Use

- Do not use the delimiter in the values of the members of *In*. If the delimiter is used in the values of the members of *In*, the SubDelimiter instruction will not correctly convert the text strings to the values of the members of a structure.
- An error occurs in the following cases. *ENO* will be FALSE, and *Out* will not change.
 - The text string that resulted from conversion exceeds 1,986 bytes, including the final NULL character.
 - A member of *In* is an array with more than one dimension.
 - A member of *In* is a union.

Version Information

A CPU Unit with unit version 1.02 or later and Sysmac Studio version 1.03 or higher are required to use this instruction.

Sample Programming

The *myStruct* structure has ten members that are SINT variables. Here, the contents of *myArray[0..99]*, which is an array of structure type *myStruct*, are stored in 100 lines of a file named 'ABC.csv' in CSV file format in the SD Memory Card. Each line contains the values of the members of an array element converted to 10 text strings. Commas are inserted between them. A CR+LF code is added to the end of each line.

The processing procedure is as follows:

- 1** The FileOpen instruction is used to open the file 'ABC.csv'
- 2** The AddDelimiter instruction is used to convert an element of *myArray[]* for one line and output the results to the *Temp* STRING variable.
- 3** The CONCAT instruction is used to concatenate *Temp* and CR+LF and then store the results in the *StrDat* STRING variable.
- 4** *StrDat* is written to the file.
- 5** Steps 2 to 4 are repeated for 100 lines.
- 6** The FileClose instruction is used to close the file.

Structure	Member	Data type
myStruct	member0	SINT
	member1	SINT
		⋮
	member9	SINT

Array *myArray[0..99]* of structure type *myStruct*

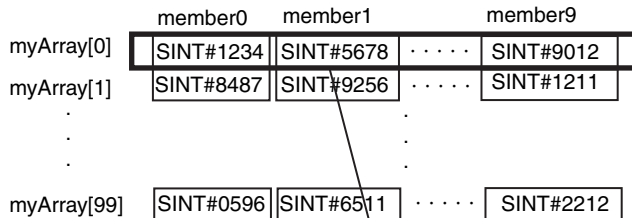

Converted to STRING data one line at a time.

STRING variable *Temp* 1234,5678, ⋮ ,9012

CR+LF added to the end.

STRING variable *StrDat* 1234,5678, ⋮ ,9012 CR+LF

Results written to the file.

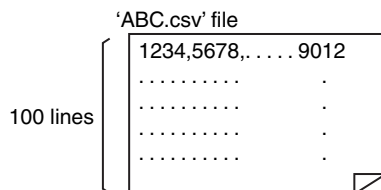

● Data Type Definition

Name	Data type	Comment
myStruct	STRUCT	Structure
member0	SINT	Member
member1	SINT	Member
member2	SINT	Member
member3	SINT	Member
member4	SINT	Member
member5	SINT	Member
member6	SINT	Member
member7	SINT	Member
member8	SINT	Member
member9	SINT	Member

LD

Internal Variables	Variable	Data type	Initial value	Comment
	OperatingEnd	BOOL	False	Processing completed
	Trigger	BOOL	False	Execution condition
	Operating	BOOL	False	Processing
	Index	INT	0	Index
	Fid	DWORD	16#0	File ID
	StrDat	STRING[256]	"	Text string data
	myArray	ARRAY[0..99] OF myStruct	[100((member0:=0,member1:=0,member2:=0,member3:=0,member4:=0,member5:=0,member6:=0,member7:=0,member8:=0,member9:=0))]	Numeric data
	Temp	STRING[256]	"	Temporary data
	RS_instance	RS		
	FileOpen_instance	FileOpen		
	FilePuts_instance	FilePuts		
	FileClose_instance	FileClose		

External Variables	Variable	Data type	Comment
	_Card1Ready	BOOL	SD Memory Card Ready Flag

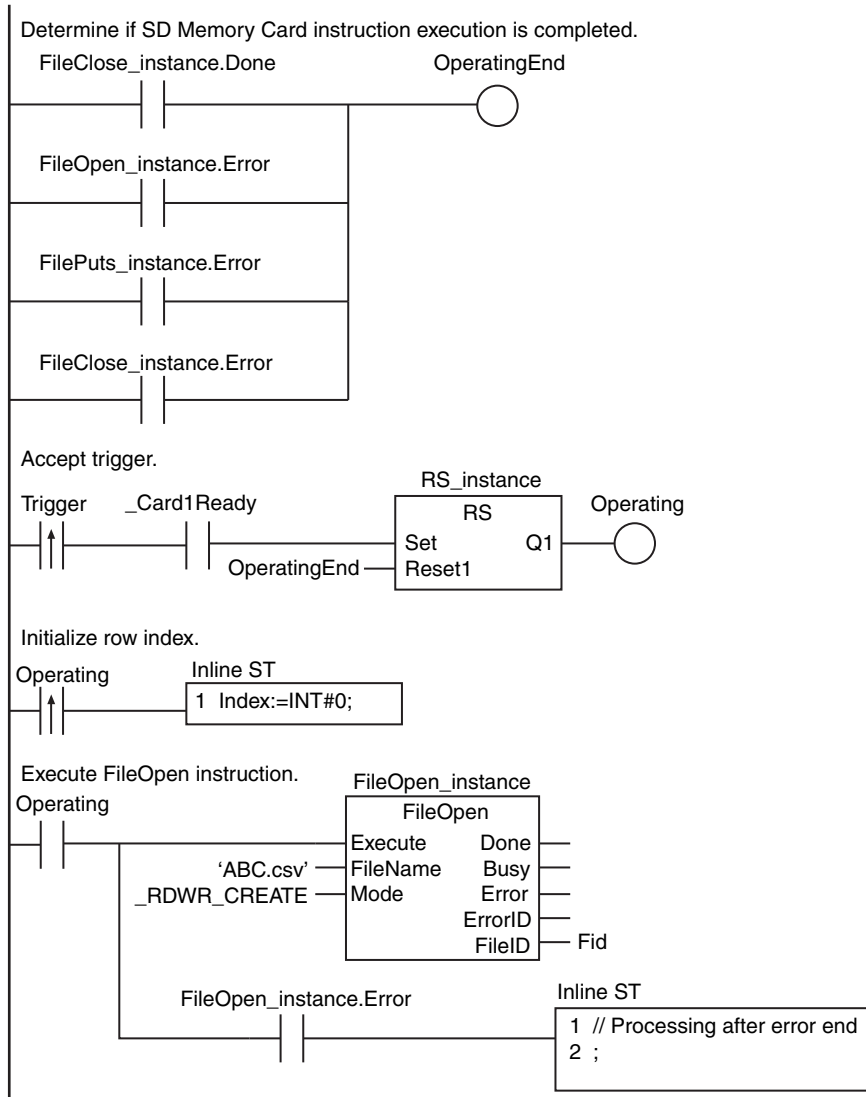

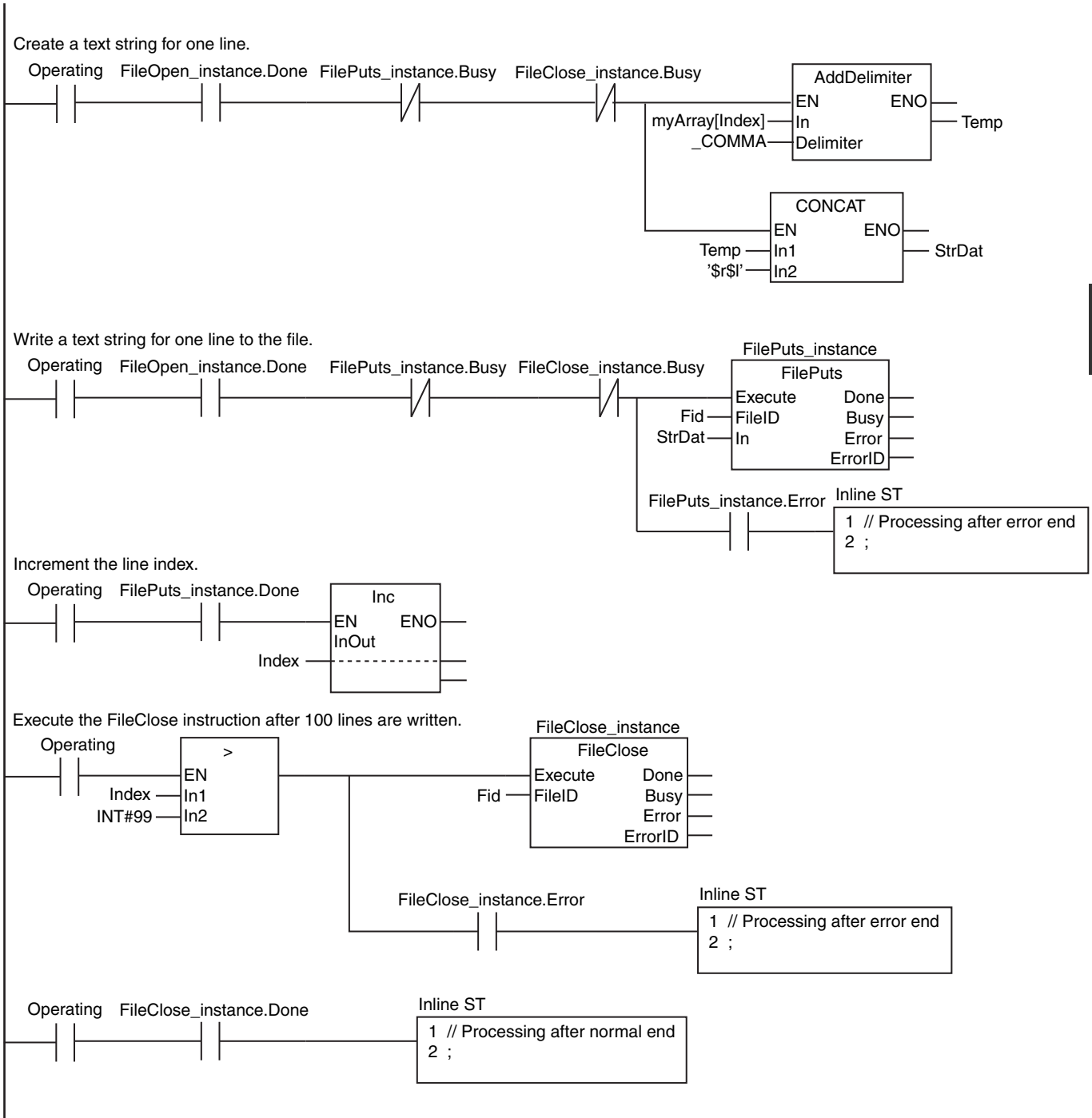

ST

Internal Variables	Variable	Data type	Initial value	Comment
	Trigger	BOOL	False	Execution condition
	LastTrigger	BOOL	False	Value of <i>Trigger</i> from previous task period
	OperatingStart	BOOL	False	Processing started
	Operating	BOOL	False	Processing
	Stage	INT	0	Stage change
	Index	INT	0	Index
	Fid	DWORD	16#0	File ID
	StrDat	STRING[256]	"	Text string data
	myArray	ARRAY[0..99] OF myStruct	[100((member0:=0,member1:=0,member2:=0,member3:=0,member4:=0,member5:=0,member6:=0,member7:=0,member8:=0,member9:=0))]	Numeric data
	Temp	STRING[256]	"	Temporary data
	FileOpen_instance	FileOpen		
	FilePuts_instance	FilePuts		
	FileClose_instance	FileClose		

External Variables	Variable	Data type	Comment
	_Card1Ready	BOOL	SD Memory Card Ready Flag

```

// Start sequence when Trigger changes to TRUE.
IF ( (Trigger=TRUE) AND (LastTrigger=FALSE) AND (_Card1Ready=TRUE) ) THEN
    OperatingStart:=TRUE;
    Operating      :=TRUE;
END_IF;
LastTrigger:=Trigger;

// Initialize instance.
IF (OperatingStart=TRUE) THEN
    FileOpen_instance(Execute:=FALSE);
    FilePuts_instance(Execute:=FALSE);
    FileClose_instance(Execute:=FALSE);
    Stage             :=INT#1;
    Index             :=INT#0;           // Initialize row index.
    OperatingStart:=FALSE;
END_IF;

// Execute instruction.
IF (Operating=TRUE) THEN
    CASE Stage OF
    1 :                               // Open file.
        FileOpen_instance(
            Execute :=TRUE,
            FileName:='ABC.csv',      // File name
            Mode     :=_RDWR_CREATE,  // Read file
            FileID   =>Fid);          // File ID

        IF (FileOpen_instance.Done=TRUE) THEN

```



```

        Stage:=INT#2;          // Normal end
    END_IF;

    IF (FileOpen_instance.Error=TRUE) THEN
        Stage:=INT#99;        // Error end
    END_IF;

2 :          // Create a text string for one line.
    StrDat:='';

    Temp :=AddDelimiter(myArray[Index],_COMMA);
    StrDat:=CONCAT(In1:=Temp, In2:='$r$l');

    Stage:=INT#3;

3 :          // Write text string.
    FilePuts_instance(
        Execute:=TRUE,
        FileID :=Fid,
        In      :=StrDat);

    IF (FilePuts_instance.Done=TRUE) THEN
        Index:=Index+INT#1;

        IF (Index>INT#99) THEN // If 100 lines were written...
            Stage:=INT#4;
        ELSE
            FilePuts_instance(Execute:=FALSE);
            Stage:=INT#2;
        END_IF;
    END_IF;

    IF (FilePuts_instance.Error=TRUE) THEN
        Stage:=INT#99;        // Error end
    END_IF;

4 :          // Close file.
    FileClose_instance(
        Execute:=TRUE,
        FileID :=Fid);          // File ID

    IF (FileClose_instance.Done=TRUE) THEN
        Operating:=FALSE;    // Normal end
    END_IF;

    IF (FileClose_instance.Error=TRUE) THEN
        Stage:=INT#99;        // Error end
    END_IF;

99 :          // Processing after error end
    Operating:=FALSE;
END_CASE;
END_IF;

```

SubDelimiter

The SubDelimiter instruction reads delimited data from a text string and stores the results as the values of the members of a structure.

Instruction	Name	FB/FUN	Graphic expression	ST expression
SubDelimiter	Get Text Strings Minus Delimiters	FUN	<pre> graph LR subgraph SubDelimiter EN[EN] In[In] OutStruct[OutStruct] Delimiter[Delimiter] ENO[ENO] Out[Out] end EN --- ENO In --- OutStruct OutStruct --- Out Delimiter --- Out </pre>	Out:=SubDelimiter(In, OutStruct, Delimiter);

Variables

Name	Meaning	I/O	Description	Valid range	Unit	Default
In	Input text string	Input	Delimited text string to convert to the values of the members of a structure	1,986 bytes max. (1,985 single-byte alphanumeric characters plus the final NULL character)	---	"
Delimiter	Delimiter		Delimiter	_COMMA, _TAB, _SEMICOLON, _SPACE	---	_COMMA
OutStruct	Storage structure	In-out	Structure to store results of data conversion	8,192 bytes max.	---	---
Out	Return value	Output	Always TRUE	TRUE only	---	---

	Boolean	Bit strings				Integers							Real numbers	Times, durations, dates, and text strings						
	BOOL	BYTE	WORD	DWORD	LWORD	USINT	UINT	UDINT	ULINT	SINT	INT	DINT	LINT	REAL	LREAL	TIME	DATE	TOD	DT	STRING
In																				OK
Delimiter	Refer to <i>Function</i> for the enumerators for the enumerated data type _eDELIMITER.																			
OutStruct	Structure																			
Out	OK																			

Function

The SubDelimiter instruction converts the delimited text string data from input text string *In* and stores the results as the values of the members of storage structure *OutStruct*. The text strings are delimited with delimiter *Delimiter*. The results are stored as the values of the members in order from the start of the structure.

The data type of *Delimiter* is enumerated type _eDELIMITER. The meanings of the enumerators are as follows:

Enumerator	Meaning
_COMMA	',' (comma)
_TAB	'\$T' (tab)
_SEMICOLON	',' (semicolon)
_SPACE	' ' (blank character)

If the number of text strings that are delimited in *In* exceeds the number of members of *OutStruct*, the remaining data is ignored.

If the number of text strings that are delimited in *In* is less than the number of members of *OutStruct*, the values of the remaining members are not changed.

If a member of *OutStruct* is a structure and there is not sufficient data in *In* for all of the members of that structure, the data is still stored as far as possible.

If a member of *OutStruct* is an array and there is not sufficient data in *In* for all of the elements of that array, the data is still stored as far as possible.

The delimited data in *In* consists of STRING data. The STRING data is converted according to data types of the members of *OutStruct*, as described next.

● Boolean Data

If the STRING data is 'FALSE' or '0', it is converted to FALSE. If the STRING data is 'TRUE' or '1', it is converted to TRUE.

The following are exceptions.

- Any continuous '0' characters before '0' or '1' are ignored.
- 'FALSE' and 'TRUE' are not case sensitive.

Conversion is not possible if the STRING data is not 'FALSE', 'TRUE', '0', or '1'.

● Bit String Data

The conversion rules are the same as for the STRING_TO_** (Text String-to-Bit String Conversion Group) instruction (page 2-301). Conversion is not possible if the data does not express a hexadecimal number.

● Integer Data

The conversion rules are the same as for the STRING_TO_** (Text String-to-Integer Conversion Group) instruction (page 2-299). Conversion is not possible if the data does not express an integer number.

● Real Number Data

The conversion rules are the same as for the STRING_TO_** (Text String-to-Real Number Conversion Group) instruction (page 2-303). Conversion is not possible if the data does not express a real number.

● Duration Data

Data with the following structure is converted to a duration.

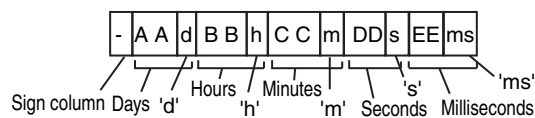

Item	Description
Sign column	If there is a '+' (positive) or if there is no sign column, the value of the member will be positive. If there is a '-' (negative), the value of the member will be negative.
Days	The value of AA is truncated after the 11th digit below the decimal point.
Hours	The value of BB is truncated after the 11th digit below the decimal point.
Minutes	The value of CC is truncated after the 10th digit below the decimal point.
Seconds	The value of DD is truncated after the 9th digit below the decimal point.
Milliseconds	The value of EE is truncated after the 6th digit below the decimal point.

- Note 1** Any ' ' (blank characters) before the sign column, days, hours, minutes, seconds, or milliseconds are ignored.
- 2 If any characters in the values of AA, BB, CC, DD, or EE are separated with a single '_' (underbar), the underbar is ignored.
 - 3 Even if the value of the days, hours, minutes, seconds, or milliseconds is a real number with a '.' (period), the data can still be converted.
 - 4 If the days, hours, minutes, seconds, or milliseconds is included in the data, conversion is possible even if the other items are omitted.
 - 5 Even if there is a '0' before the value of the days, hours, minutes, seconds, or milliseconds, the data can still be converted.

Conversion is not possible in the following cases.

- The data is not in the above structure.
- There is an '_' (underbar) between the sign column and the days.
- '.' (periods) or '_' (underbars) appear consecutively.

For example, if the STRING data is '-0.5d48h0.123456789ms', the value of the member will be T#-2d12h0m0s0.123456ms(T#-216000000.123456ms).

● **Date Data**

Data with the following structure is converted to a date.

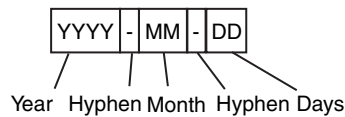

The following are exceptions.

- Any ' ' (blank characters) before the year, month, or day are ignored.
- If any characters in the values of the year, month, or day are separated with a single '_' (underbar), the underbar is ignored.
- Even if there is a '0' before the value of the year, month, or day, the data can still be converted.

Conversion is not possible in the following cases.

- The data is not in the above structure.
- The date does not exist.

For example, if the STRING data is '2000-1-01', the value of the member will be D#2000-01-01.

● **Date and Time Data**

Data with the following structure is converted to a duration.

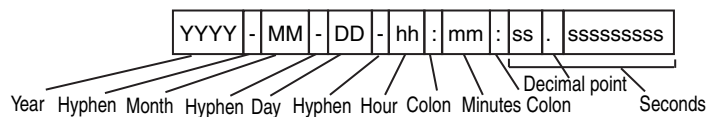

Item	Description
Year, month, and day	This is the year, month, and day that express the date.
Hour	The range of the value is 0 to 23.
Minutes	The range of the value is 0 to 59.
Seconds	The range of the value is 0 to 59.99999999. If the value is an integer, a decimal point is not required.
Hyphens and colons	These are always required.

- Note 1** Any ' ' (blank characters) before the year, month, day, hour, minutes, or seconds are ignored.

- 2 If any characters in the values of the year, month, day, hour, minutes, or seconds are separated with a single ‘_’ (underbar), the underbar is ignored.
- 3 Even if there is a ‘0’ before the value of the year, month, day, hour, minutes, or seconds, the data can still be converted.

Conversion is not possible in the following cases.

- The data is not in the above structure.
- The date does not exist.

For example, if the STRING data is ‘2000-01-23-4:56:07.89’, the value of the member will be DT#2000-01-23-04:56:07.89.

● **Time of Day Data**

Data with the following structure is converted to a time of day.

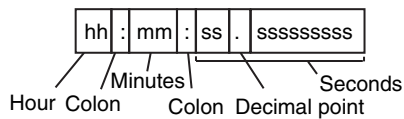

Item	Description
Hour	The range of the value is 0 to 23.
Minutes	The range of the value is 0 to 59.
Seconds	The range of the value is 0 to 59.999999999. If the value is an integer, a decimal point (‘.’ (period)) is not required.
Colons	These are always required.

- Note 1** Any ‘ ’ (blank characters) before the hour, minutes, or seconds are ignored.
- 2 If any characters in the values of hour, minutes, or seconds are separated with a single ‘_’ (underbar), the underbar is ignored.
 - 3 Even if there is a ‘0’ before the value of the hour, minutes, or seconds, the data can still be converted.

Conversion is not possible in the following cases.

- The data is not in the above structure.
- ‘.’ (periods) or ‘_’ (underbars) appear consecutively.

For example, if the STRING data is ‘12:23:34.567’, the value of the member will be TOD#12:23:34.567.

● **Text String Data**

The value of the member will be the data with a NULL character added to the end. However, conversion is not possible if the text string exceeds the size of the member.

For example, if the STRING data is ‘ABC’ without a NULL character at the end, the value of the member will be ‘ABC’ with a NULL character at the end.

● **Structure Data**

The STRING data is converted according to the conversion rules for the data types of the members. The data is converted in order from the start and stored as the values of the members of the structure down to the nesting levels that are not structures. For example, if a member of structure A is *Structure_B*, the conversion works as shown below.

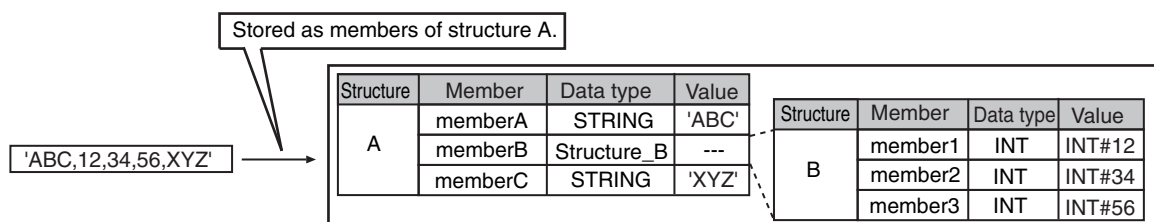

● **Enumeration Data**

STRING data that expresses a DINT variable is converted to an enumerator of the enumeration. The same rules as for integers are used to convert to DINT data, the value of the DINT data is taken as the value of the enumeration, and that value is converted to the corresponding enumerator. However, conversion is not possible if the STRING data does not express a DINT value. For example, assume that an enumeration *Color* has three enumerators: *red*, *yellow*, and *green*. The numbers associated with these enumerators are as follows: *red* = 1, *yellow* = 2, *green* = 3. If the data is '3', the value of the member will be *green*.

● **Array Data**

Each delimited data is converted to the value of an element. The conversion rules for the data type of the array are used. Conversion is possible only if the members are one-dimensional arrays. For example, assume that a member is the *myString[0..3]* BYTE array. If the comma-delimited text string 'AA,BB,CC,DD' is converted to the elements of the array, *myString[0]* will be BYTE#16#AA, *myString[1]* will be BYTE#16#BB, *myString[2]* will be BYTE#16#CC, and *myString[3]* will be BYTE#16#DD.

Notation Example

The following notation reads comma-delimited data from the myString text string and stores the text strings as the values of the members of the myStruct structure.

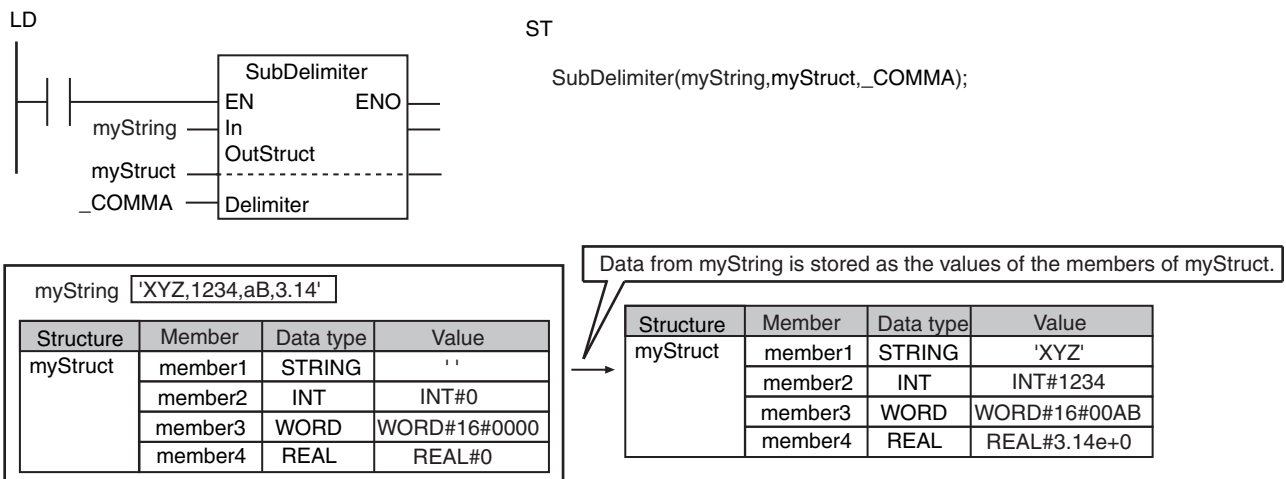

Additional Information

- You can combine this instruction with the *FileGets instruction* (page 2-1375) to easily read values from specified CSV files in an SD Memory Card. Refer to *Sample Programming* for an application example.
- Use this instruction to return a text string that was converted with the *AddDelimiter instruction* (page 2-571) to structure data.

Precautions for Correct Use

- If there is more than one consecutive delimiter in *In*, the delimited data will not exist. If the delimited data does not exist, the value of the member of *OutStruct* will be undefined.
- Do not use the delimiter in *In* for anything other than the delimiter. If you use the delimiter for any other purpose, the instruction will still treat it as a delimiter.

- If there is a **STRING** member in *OutStruct*, do not attach a final **NULL** character to the corresponding data in *In*. If you use a **NULL** character anywhere except at the end of *In*, only the text string through the first **NULL** character will be converted.
- If there is an enumeration in *OutStruct*, make sure that the corresponding data in *In* is a value that is defined as an enumerator. An error will not occur even if the value of the enumerated variable is not a value that is defined as an enumerator.
- An error occurs in the following cases. *ENO* changes to **FALSE** and the values in *OutStruct* will be undefined.
 - Conversion to a value with the data type of the member of *OutStruct* is not possible.
 - The conversion result exceeds the valid range of the value of the data type of the member of *OutStruct*.
 - A member of *OutStruct* is an array with more than one dimension.
 - A member of *OutStruct* is a union.
 - The size of *OutStruct* exceeds 8,192 bytes.

Version Information

A CPU Unit with unit version 1.02 or later and Sysmac Studio version 1.03 or higher are required to use this instruction.

Sample Programming

Here, multiple lines of text strings that are separated by carriage returns (i.e., CR codes) are stored in a file named 'ABC.csv.' The text string on each line is delimited by commas. Text strings are read from this file one line at a time, and the comma-delimited data is stored as the values of the members of the *myArray[]* array variables in the *myStruct* structure from the start of the structure. The *myStruct* structure has five members that are **STRING** variables.

Processing ends when the data is read to the end of the file (i.e., when it is read to the EOF code).

'ABC.csv' file

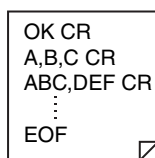

Lines are read one at a time and stored in *myArray[]* members.

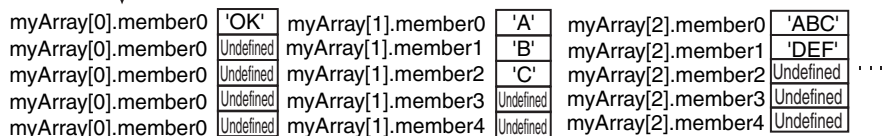

The processing procedure is as follows:

- 1** The **FileOpen** instruction is used to open the file 'ABC.csv.'
- 2** The **FileGets** instruction is used to read one line from the file.
- 3** The **SubDelimiter** is used to store comma-delimited text strings as the values of the *myArray[]* members.
- 4** Steps 2 and 3 are repeated until the **EOF** (end of file).
- 5** The **FileClose** instruction is used to close the file.

● Data Type Definition

Name	Data type	Comment
myStruct	STRUCT	Structure
member0	STRING	Member
member1	STRING	Member
member2	STRING	Member
member3	STRING	Member
member4	STRING	Member

LD

Internal Variables	Variable	Data type	Initial value	Comment
	OperatingEnd	BOOL	False	Processing completed
	Trigger	BOOL	False	Execution condition
	Operating	BOOL	False	Processing
	Index	INT	0	myArray[] element index
	Fid	DWORD	16#0	File ID
	myArray	ARRAY[0..999] OF myStruct	[1000((member0:=",member1:=",member2:=",member3:=",member4:="))]	Integer data
	RS_instance	RS		
	FileOpen_instance	FileOpen		
	FileGets_instance	FileGets		
	FileClose_instance	FileClose		

External Variables	Variable	Data type	Comment
	_Card1Ready	BOOL	SD Memory Card Ready Flag

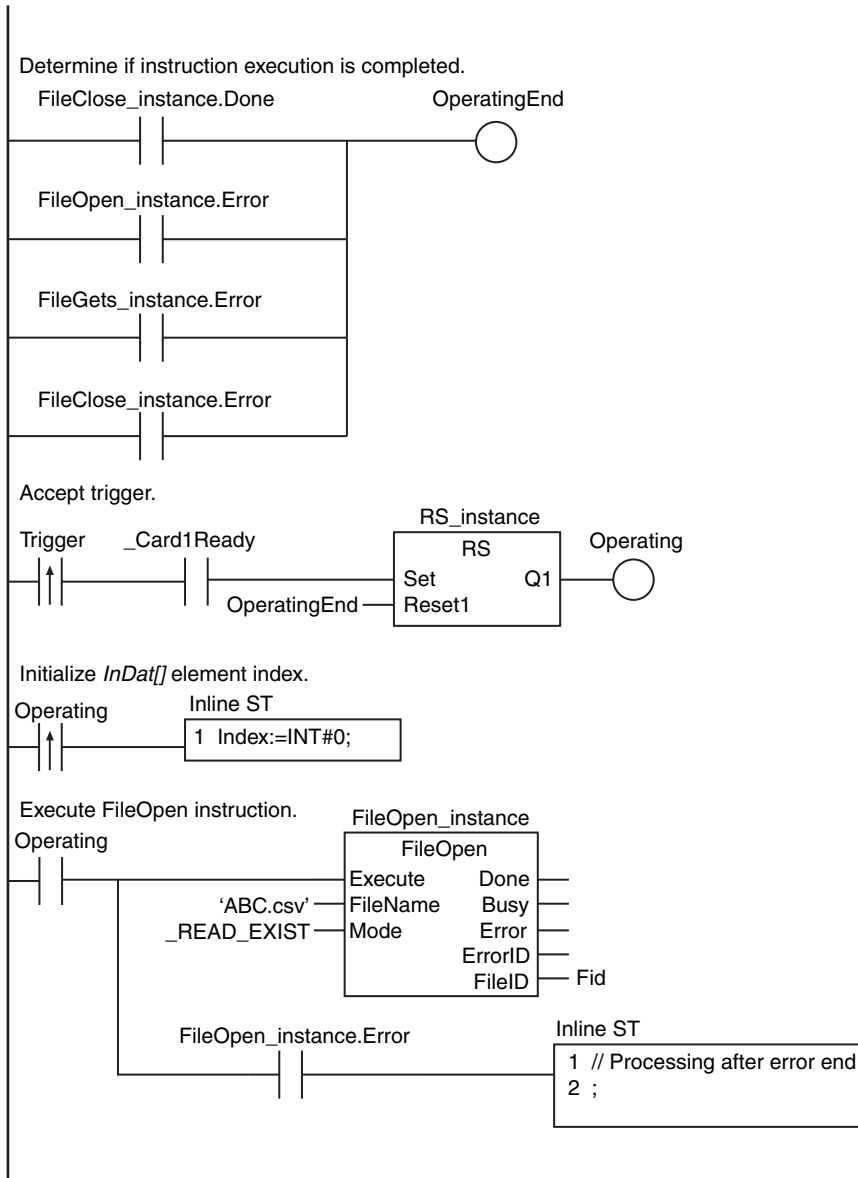

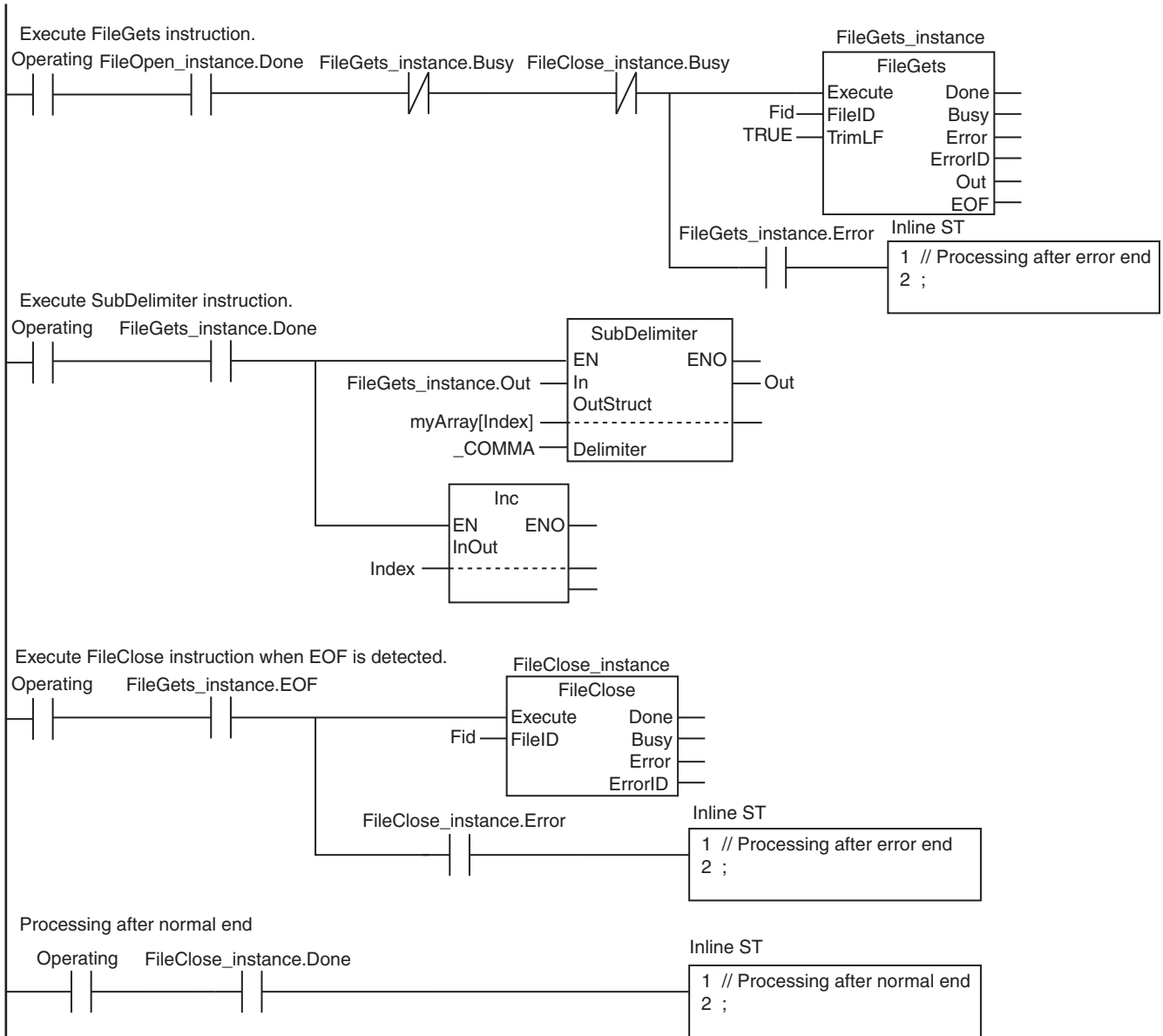

ST

Internal Variables	Variable	Data type	Initial value	Comment
	Trigger	BOOL	False	Execution condition
	LastTrigger	BOOL	False	Value of <i>Trigger</i> from previous task period
	OperatingStart	BOOL	False	Processing started
	Operating	BOOL	False	Processing
	myArray	ARRAY[0..999] OF myStruct	[1000((member0:="",member1:="",member2:="",member3:="",member4:=""))]	Integer data
	Stage	INT	0	Stage change
	Index	INT	0	myArray[] element index
	Fid	DWORD	16#0	File ID
	FileOpen_instance	FileOpen		
	FileGets_instance	FileGets		
	FileClose_instance	FileClose		

External Variables	Variable	Data type	Comment
	_Card1Ready	BOOL	SD Memory Card Ready Flag

```

// Start sequence when Trigger changes to TRUE.
IF ( (Trigger=TRUE) AND (LastTrigger=FALSE) AND (_Card1Ready=TRUE) ) THEN
    OperatingStart:=TRUE;
    Operating      :=TRUE;
END_IF;
LastTrigger:=Trigger;

// Initialize instance.
IF (OperatingStart=TRUE) THEN
    FileOpen_instance(Execute:=FALSE);
    FileGets_instance(Execute:=FALSE);
    FileClose_instance(Execute:=FALSE);
    Stage             :=INT#1;
    Index             :=INT#0;
    OperatingStart:=FALSE;
END_IF;

// Execute instruction.
IF (Operating=TRUE) THEN
    CASE Stage OF
    1 : // Open file.
        FileOpen_instance(
            Execute :=TRUE,
            FileName:='ABC.csv', // File name
            Mode     :=_READ_EXIST, // Read file
            FileID   =>Fid); // File ID

        IF (FileOpen_instance.Done=TRUE) THEN
            Stage:=INT#2; // Normal end
        END_IF;

        IF (FileOpen_instance.Error=TRUE) THEN

```

```

        Stage:=INT#99;        // Error end
    END_IF;

2 :                // Read text string.
    FileGets_instance(
        Execute:=TRUE,
        FileID :=Fid,
        TrimLF :=TRUE);

    IF (FileGets_instance.Done=TRUE) THEN
        // Store the text strings that were read as the values of the
myArray[] member.
        SubDelimiter(FileGets_instance.Out,myArray[Index] ,_COMMA);
        Index:=Index+INT#1;

        // Reached end of file.
        IF (FileGets_instance.EOF=TRUE) THEN
            Stage:=INT#3;    // Normal end
        ELSE
            FileGets_instance(Execute:=FALSE);
        END_IF;
    END_IF;

    IF (FileGets_instance.Error=TRUE) THEN
        Stage:=INT#99;        // Error end
    END_IF;

3 :                // Close file.
    FileClose_instance(
        Execute:=TRUE,
        FileID :=Fid);        // File ID

    IF (FileClose_instance.Done=TRUE) THEN
        Operating:=FALSE;    // Normal end
    END_IF;

    IF (FileClose_instance.Error=TRUE) THEN
        Stage:=INT#99;        // Error end
    END_IF;

99 :                // Processing after error end
    Operating:=FALSE;
END_CASE;
END_IF;

```

Time and Time of Day Instructions

Instruction	Name	Page	Instruction	Name	Page
ADD_TIME	Add Time	2-594	TodToSec	Convert Time of Day to Seconds	2-627
ADD_TOD_TIME	Add Time to Time of Day	2-596	SecToDt	Convert Seconds to Date and Time	2-628
ADD_DT_TIME	Add Time to Date and Time	2-598	SecToDate	Convert Seconds to Date	2-630
SUB_TIME	Subtract Time	2-600	SecToTod	Convert Seconds to Time of Day	2-632
SUB_TOD_TIME	Subtract Time from Time of Day	2-602	TimeToNanoSec	Convert Time to Nanoseconds	2-634
SUB_TOD_TOD	Subtract Time of Day	2-604	TimeToSec	Convert Time to Seconds	2-635
SUB_DATE_DATE	Subtract Date	2-605	NanoSecToTime	Convert Nanoseconds to Time	2-636
SUB_DT_DT	Subtract Date and Time	2-606	SecToTime	Convert Seconds to Time	2-637
SUB_DT_TIME	Subtract Time from Date and Time	2-608	ChkLeapYear	Check for Leap Year	2-639
MULTIME	Multiply Time	2-610	GetDaysOfMonth	Get Days in Month	2-640
DIVTIME	Divide Time	2-612	DaysToMonth	Convert Days to Month	2-642
CONCAT_DATE_TOD	Concatenate Date and Time of Day	2-614	GetDayOfWeek	Get Day of Week	2-644
DT_TO_TOD	Extract Time of Day from Date and Time	2-616	GetWeekOfYear	Get Week Number	2-646
DT_TO_DATE	Extract Date from Date and Time	2-618	DtToDateStruct	Break Down Date and Time	2-648
SetTime	Set Time	2-620	DateStructToDt	Join Time	2-650
GetTime	Get Time of Day	2-622	TruncTime	Truncate Time	2-652
DtToSec	Convert Date and Time to Seconds	2-624	TruncDt	Truncate Date and Time	2-656
DateToSec	Convert Date to Seconds	2-626	TruncTod	Truncate Time of Day	2-660

ADD_TIME

The ADD_TIME instruction adds two times.

Instruction	Name	FB/FUN	Graphic expression	ST expression
ADD_TIME	Add Time	FUN		Out:=ADD_TIME(In1, In2);

Variables

Name	Meaning	I/O	Description	Valid range	Unit	Default
In1	Add time 1	Input	Add time 1	Depends on data type.	ns	T#0s
In2	Add time 2		Add time 2			
Out	Total time	Output	Total time	Depends on data type.	ns	---

	Boolean	Bit strings					Integers							Real numbers	Times, durations, dates, and text strings					
	BOOL	BYTE	WORD	DWORD	LWORD	USINT	UINT	UDINT	ULINT	SINT	INT	DINT	LINT	REAL	LREAL	TIME	DATE	TOD	DT	STRING
In1																OK				
In2																OK				
Out																OK				

Function

The ADD_TIME instruction adds two times, *In1* and *In2*. The result of addition in *Out* is also a time. The following example is for when *In1* is T#1d2h3m4s and *In2* is T#5d6h7m8s.

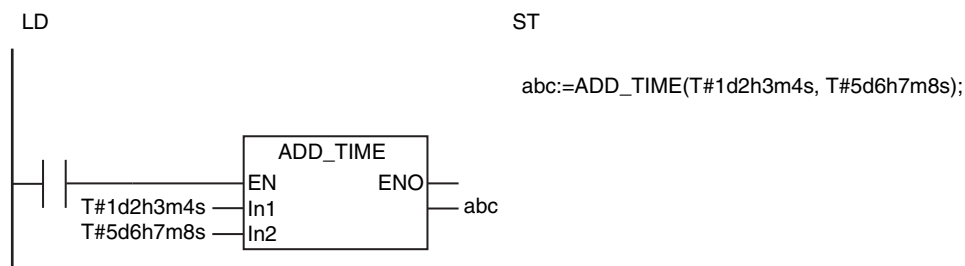

	In1	T#1d2h3m4s
+	In2	T#5d6h7m8s
Out=abc T#6d8h10m12s		

Precautions for Correct Use

An error will not occur even if the addition result exceeds the valid range of *Out*.

- $T\#106751d_23h_47m_16s_854.775807ms + T\#0.000001ms$
→ $T\#-106751d_23h_47m_16s_854.775808ms$
- $T\#-106751d_23h_47m_16s_854.775808ms + T\#-0.000001ms$
→ $T\#106751d_23h_47m_16s_854.775807ms$

ADD_TOD_TIME

The ADD_TOD_TIME instruction adds a time to a time of day.

Instruction	Name	FB/FUN	Graphic expression	ST expression
ADD_TOD_TIME	Add Time to Time of Day	FUN		Out:=ADD_TOD_TIME(In1, In2);

Variables

Name	Meaning	I/O	Description	Valid range	Unit	Default
In1	Add time of day	Input	Add time of day	Depends on data type.	Hour, minutes, seconds	TOD#0:0:0
In2	Add time		Add time		ns	T#0s
Out	Resulting time of day	Output	Resulting time of day	Depends on data type.	Hour, minutes, seconds	---

	Boolean	Bit strings					Integers							Real numbers	Times, durations, dates, and text strings					
	BOOL	BYTE	WORD	DWORD	LWORD	USINT	UINT	UDINT	ULINT	SINT	INT	DINT	LINT	REAL	LREAL	TIME	DATE	TOD	DT	STRING
In1																		OK		
In2																OK				
Out																		OK		

Function

The ADD_TOD_TIME instruction adds a time, *In2*, to a time of day *In1*. The result of addition in *Out* is also a time of day.

The following example is for when *In1* is TOD#23:59:59.999999999 and *In2* is T#1d0h0m0.000000001s.

LD ST

```

abc:=ADD_TOD_TIME(TOD#23:59:59.999999999,
                  T#1d0h0m0.000000001s);
    
```

In1	TOD#23:59:59.999999999	
+	In2	T#1d0h0m0.000000001s

Out=abc	TOD#0:0:0.000000000	

Precautions for Correct Use

An error will not occur even if the addition result exceeds the valid range of *Out*.

- $\text{TOD\#23:59:59.999999999} + \text{T\#0.000001ms} \rightarrow \text{TOD\#0:0:0.000000000}$
- $\text{TOD\#0:0:0.000000000} + \text{T\#-0.000001ms} \rightarrow \text{TOD\#23:59:59.999999999}$

ADD_DT_TIME

The ADD_DT_TIME instruction adds a time to a date and time.

Instruction	Name	FB/FUN	Graphic expression	ST expression
ADD_DT_TIME	Add Time to Date and Time	FUN		Out:=ADD_DT_TIME(In1, In2);

Variables

Name	Meaning	I/O	Description	Valid range	Unit	Default
In1	Add date and time	Input	Add date and time	Depends on data type.	Year, month, day, hour, minutes, seconds	DT#197 0-1-1-0:0:0
In2	Add time		Add time		ns	T#0s
Out	Addition result date and time	Output	Addition result date and time	Depends on data type.	Year, month, day, hour, minutes, seconds	---

	Boolean	Bit strings					Integers							Real numbers		Times, durations, dates, and text strings				
	BOOL	BYTE	WORD	DWORD	LWORD	USINT	UINT	UDINT	ULINT	SINT	INT	DINT	LINT	REAL	LREAL	TIME	DATE	TOD	DT	STRING
In1																			OK	
In2																OK				
Out																			OK	

Function

The ADD_DT_TIME instruction adds a time, *In2*, to a date and time *In1*. The result of addition in *Out* is also a date and time. Leap years are also accounted for. The following example is for when *In1* is DT#1970-1-1-0:0:0 and *In2* is T#1d.

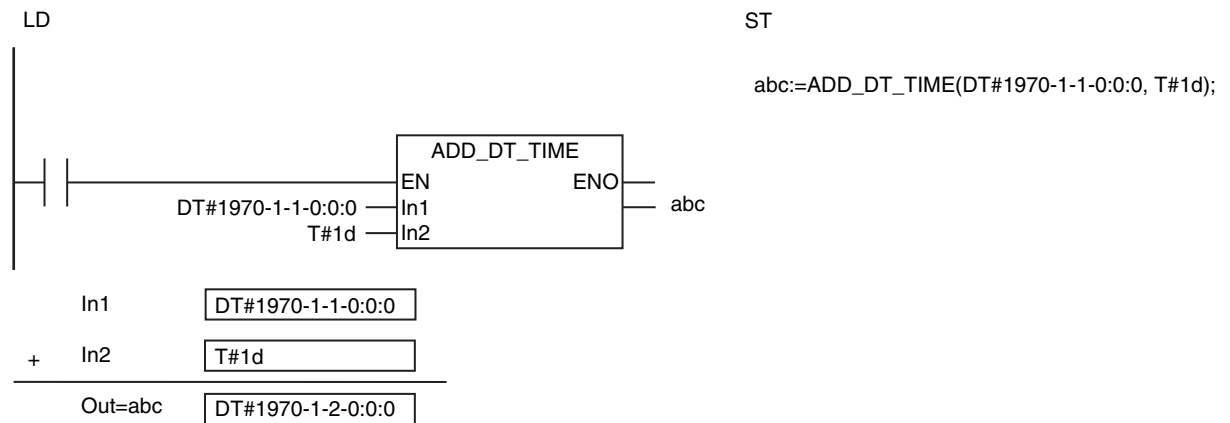

Related System-defined Variables

Name	Meaning	Data type	Description
_CurrentTime	System Time of Day	DT	The time of day from the system clock. The number of seconds from 00:00:00 on January 1, 1970.

Precautions for Correct Use

An error will not occur even if the addition result exceeds the valid range of *Out*.

- DT#2554-7-21-23:34:33.709551615 + T#0.000001ms → DT#1970-1-1-0:0:0
- DT#1970-1-1-0:0:0 + T#-0.000001ms → DT#2554-7-21-23:34:33.709551615

SUB_TIME

The SUB_TIME instruction subtracts one time from another.

Instruction	Name	FB/FUN	Graphic expression	ST expression
SUB_TIME	Subtract Time	FUN		Out:=SUB_TIME(In1, In2);

Variables

Name	Meaning	I/O	Description	Valid range	Unit	Default
In1	Original time	Input	Original time	Depends on data type.	ns	T#0s
In2	Time to subtract		Time to subtract			
Out	Resulting time	Output	Resulting time	Depends on data type.	ns	---

	Boolean	Bit strings					Integers							Real numbers	Times, durations, dates, and text strings					
	BOOL	BYTE	WORD	DWORD	LWORD	USINT	UINT	UDINT	ULINT	SINT	INT	DINT	LINT	REAL	LREAL	TIME	DATE	TOD	DT	STRING
In1																OK				
In2																OK				
Out																OK				

Function

The SUB_TIME instruction subtracts a time *In2* from another time *In1*. The result of subtraction in *Out* is also a time.

The following example is for when *In1* and *In2* are T#1d.

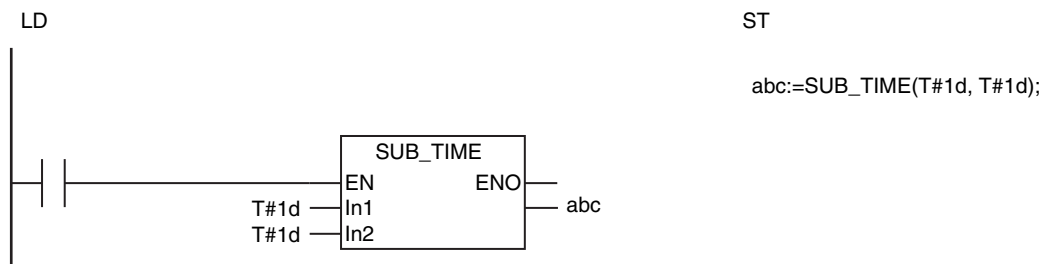

In1	T#1d
- In2	T#1d
Out=abc	T#0s

Precautions for Correct Use

An error will not occur even if the subtraction result exceeds the valid range of *Out*.

- T#106751d_23h_47m_16s_854.775807ms – T#-0.000001ms
→ T#-106751d_23h_47m_16s_854.775808ms
- T#-106751d_23h_47m_16s_854.775808ms – T#0.000001ms
→ T#106751d_23h_47m_16s_854.775807ms

SUB_TOD_TIME

The SUB_TOD_TIME instruction subtracts a time from a time of day.

Instruction	Name	FB/FUN	Graphic expression	ST expression
SUB_TOD_TIME	Subtract Time from Time of Day	FUN		Out:=SUB_TOD_TIME(In1, In2);

Variables

Name	Meaning	I/O	Description	Valid range	Unit	Default
In1	Time of day	Input	Time of day	Depends on data type.	Hour, minutes, seconds	TOD#0:0:0
In2	Time to subtract		Time to subtract		ns	T#0s
Out	Resulting time of day	Output	Resulting time of day	Depends on data type.	Hour, minutes, seconds	---

	Boolean	Bit strings					Integers							Real numbers	Times, durations, dates, and text strings					
	BOOL	BYTE	WORD	DWORD	LWORD	USINT	UINT	UDINT	ULINT	SINT	INT	DINT	LINT	REAL	LREAL	TIME	DATE	TOD	DT	STRING
In1																		OK		
In2																OK				
Out																		OK		

Function

The SUB_TOD_TIME instruction subtracts a time *In2* from a time of day *In1*. The result of subtraction in *Out* is also a time of day.

The following example is for when *In1* is TOD#23:59:59 and *In2* is T#1s.

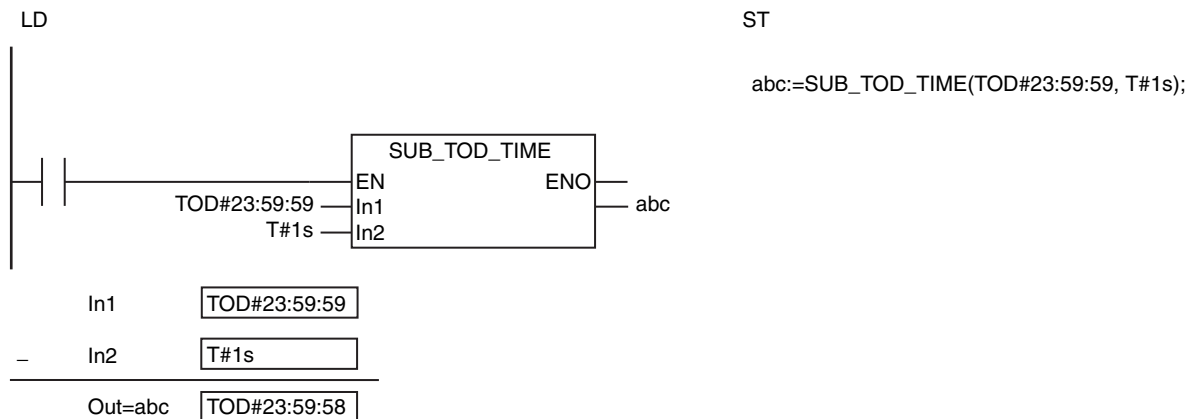

Precautions for Correct Use

An error will not occur even if the subtraction result exceeds the valid range of *Out*.

- $\text{TOD\#23:59:59.999999999} - \text{T\#-0.000001ms} \rightarrow \text{TOD\#0:0:0}$
- $\text{TOD\#0:0:0} - \text{T\#0.000001ms} \rightarrow \text{TOD\#23:59:59.999999999}$

SUB_TOD_TOD

The SUB_TOD_TOD instruction subtracts a time of day from another time of day.

Instruction	Name	FB/FUN	Graphic expression	ST expression
SUB_TOD_TOD	Subtract Time of Day	FUN		Out:=SUB_TOD_TOD(In1, In2);

Variables

Name	Meaning	I/O	Description	Valid range	Unit	Default
In1	Time of day 1	Input	Time of day 1	Depends on data type.	Hour, minutes, seconds	TOD#0:0:0
In2	Time of day 2		Time of day 2			
Out	Resulting time	Output	Resulting time	Depends on data type.	ns	---

	Boolean	Bit strings					Integers							Real numbers		Times, durations, dates, and text strings				
	BOOL	BYTE	WORD	DWORD	LWORD	USINT	UINT	UDINT	ULINT	SINT	INT	DINT	LINT	REAL	LREAL	TIME	DATE	TOD	DT	STRING
In1																		OK		
In2																		OK		
Out															OK					

Function

The SUB_TOD_TOD instruction subtracts time of day *In2* from time of day *In1*. The result of subtraction in *Out* is a time.

The following example is for when *In1* is TOD#23:59:59.999999999 and *In2* is TOD#23:59:50.000000000.

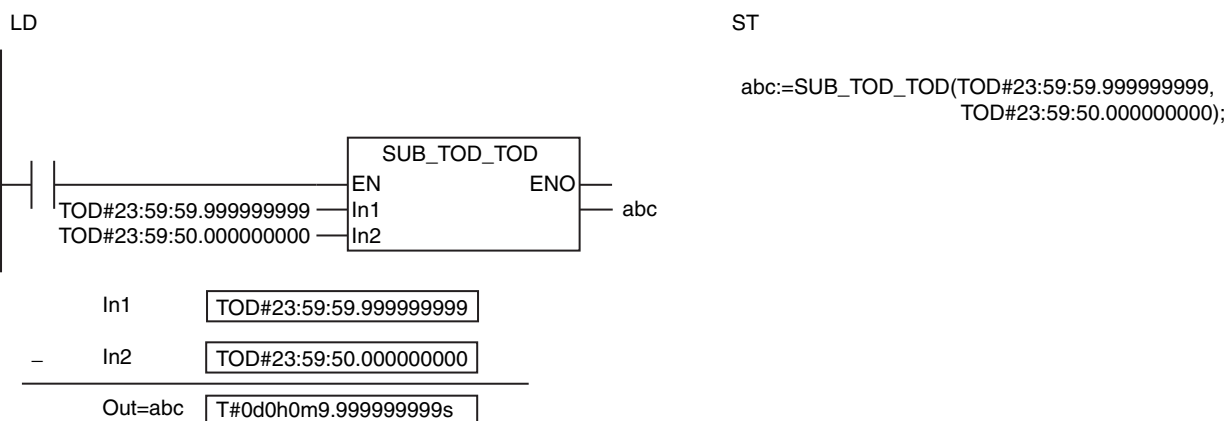

SUB_DATE_DATE

The SUB_DATE_DATE instruction subtracts another date from another date.

Instruction	Name	FB/FUN	Graphic expression	ST expression
SUB_DATE_DATE	Subtract Date	FUN		Out:=SUB_DATE_DATE(In1, In2);

Variables

Name	Meaning	I/O	Description	Valid range	Unit	Default
In1	Date 1	Input	Date 1	Depends on data type.	Year, month, day	D#1970-1-1
In2	Date 2		Date 2			
Out	Resulting time	Output	Resulting time	Depends on data type.	ns	---

	Boolean	Bit strings				Integers							Real numbers		Times, durations, dates, and text strings					
	BOOL	BYTE	WORD	DWORD	LWORD	USINT	UINT	UDINT	ULINT	SINT	INT	DINT	LINT	REAL	LREAL	TIME	DATE	TOD	DT	STRING
In1																OK				
In2																OK				
Out															OK					

Function

The SUB_DATE_DATE instruction subtracts date *In2* from date *In1*. The result of subtraction in *Out* is a time.

The following example is for when *In1* is D#1970-1-7 and *In2* is D#1970-1-2.

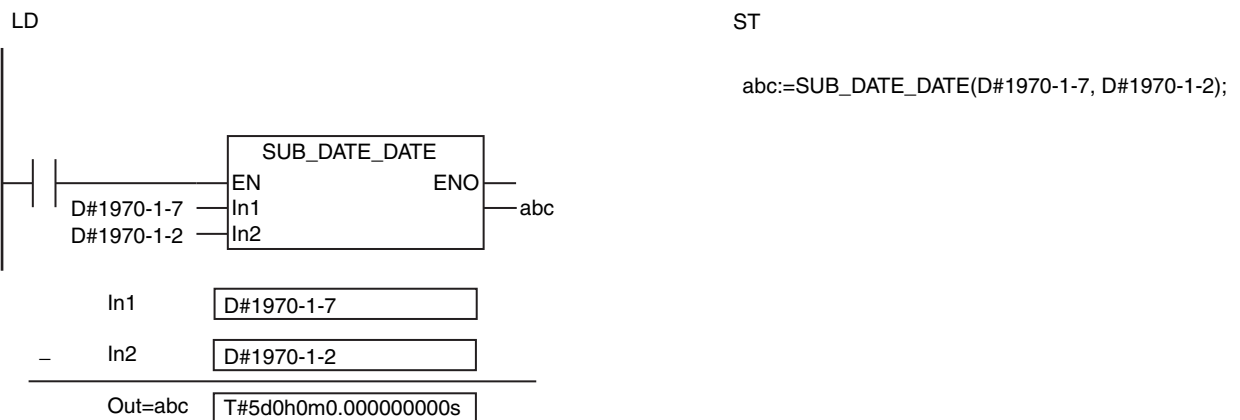

SUB_DT_DT

The SUB_DT_DT instruction subtracts another date and time from another date and time.

Instruction	Name	FB/FUN	Graphic expression	ST expression
SUB_DT_DT	Subtract Date and Time	FUN		Out:=SUB_DT_DT(In1, In2);

Variables

Name	Meaning	I/O	Description	Valid range	Unit	Default
In1	Date and time 1	Input	Date and time 1	Depends on data type.	Year, month, day, hour, minutes, seconds	DT#1970-1-1-0:0:0
In2	Date and time 2		Date and time 2			
Out	Resulting time	Output	Resulting time	Depends on data type.	ns	---

	Boolean	Bit strings					Integers							Real numbers	Times, durations, dates, and text strings					
	BOOL	BYTE	WORD	DWORD	LWORD	USINT	UINT	UDINT	ULINT	SINT	INT	DINT	LINT	REAL	LREAL	TIME	DATE	TOD	DT	STRING
In1																			OK	
In2																			OK	
Out															OK					

Function

The SUB_DT_DT instruction subtracts date and time *In2* from date and time *In1*. The result of subtraction in *Out* is a time.

The following example is for when *In1* is DT#1970-1-7-0:0:0 and *In2* is DT#1970-1-2-0:0:0.

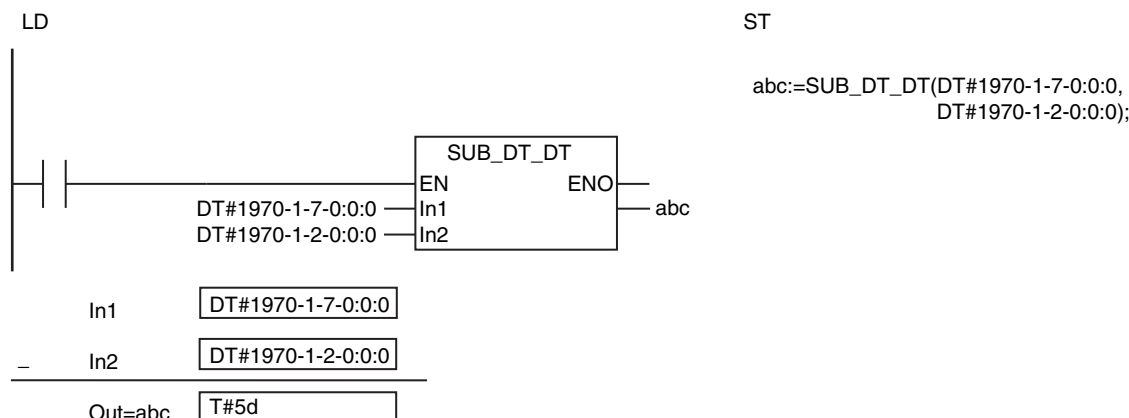

Related System-defined Variables

Name	Meaning	Data type	Description
_CurrentTime	System Time of Day	DT	The time of day from the system clock. The number of seconds from 00:00:00 on January 1, 1970.

Precautions for Correct Use

If the processing result exceeds the valid range of *Out*, *Out* will contain an illegal value.

SUB_DT_TIME

The SUB_DT_TIME instruction subtracts a time from a date and time.

Instruction	Name	FB/FUN	Graphic expression	ST expression
SUB_DT_TIME	Subtract Time from Date and Time	FUN		Out:=SUB_DT_TIME(In1, In2);

Variables

Name	Meaning	I/O	Description	Valid range	Unit	Default
In1	Date and time	Input	Date and time	Depends on data type.	Year, month, day, hour, minutes, seconds	DT#1970-1-1-0:0:0
In2	Time to subtract		Time to subtract		ns	T#0s
Out	Resulting date and time	Output	Resulting date and time	Depends on data type.	Year, month, day, hour, minutes, seconds	---

	Boolean	Bit strings					Integers							Real numbers		Times, durations, dates, and text strings				
	BOOL	BYTE	WORD	DWORD	LWORD	USINT	UINT	UDINT	ULINT	SINT	INT	DINT	LINT	REAL	LREAL	TIME	DATE	TOD	DT	STRING
In1																			OK	
In2																OK				
Out																			OK	

Function

The SUB_DT_TIME instruction subtracts a time *In2* from a date and time *In1*. The result of subtraction in *Out* is a date and time. Leap years are also accounted for.

The following example is for when *In1* is DT#1970-1-1-0:0:0 and *In2* is T#1d.

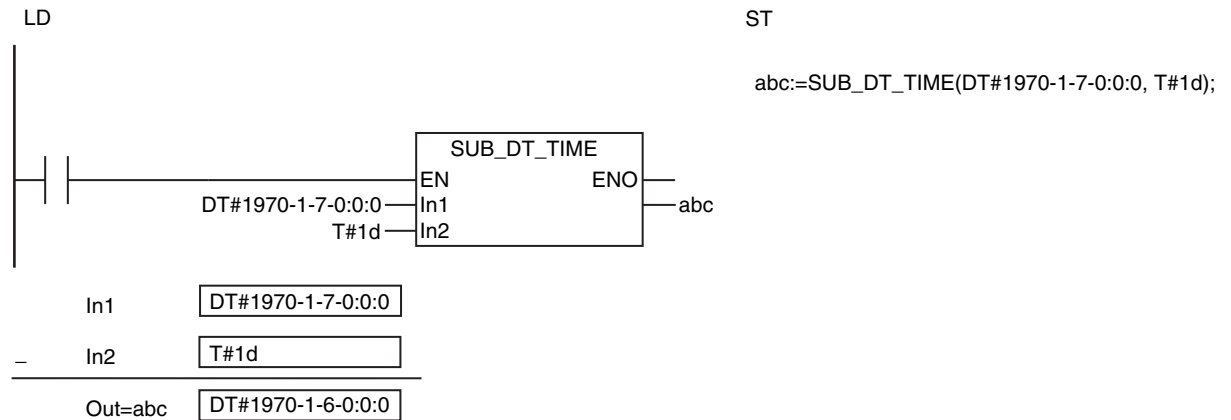

Related System-defined Variables

Name	Meaning	Data type	Description
_CurrentTime	System Time of Day	DT	The time of day from the system clock. The number of seconds from 00:00:00 on January 1, 1970.

Precautions for Correct Use

An error will not occur even if the subtraction result exceeds the valid range of *Out*.

- DT#2554-7-21-23:34:33.709551615 – T#-0.000001ms → DT#1970-1-1-0:0:0
- DT#1970-1-1-0:0:0 – T#0.000001ms → DT#2554-7-21-23:34:33.709551615

MULTIME

The MULTIME instruction multiplies a time by a specified number.

Instruction	Name	FB/FUN	Graphic expression	ST expression
MULTIME	Multiply Time	FUN		Out:=MULTIME(In1, In2);

Variables

Name	Meaning	I/O	Description	Valid range	Unit	Default
In1	Original time	Input	Original time	Depends on data type.	ns	T#0s
In2	Multiplier		Multiplier		---	*
Out	Resulting time	Output	Resulting time	Depends on data type.	ns	---

* If you omit the input parameter, the default value is not applied. A building error will occur.

	Boolean	Bit strings					Integers								Real numbers		Times, durations, dates, and text strings				
	BOOL	BYTE	WORD	DWORD	LWORD	USINT	UINT	UDINT	ULINT	SINT	INT	DINT	LINT	REAL	LREAL	TIME	DATE	TOD	DT	STRING	
In1																OK					
In2						OK	OK	OK	OK	OK	OK	OK	OK	OK	OK						
Out																OK					

Function

The MULTIME instruction multiplies a time *In1* by multiplier *In2*. The result of multiplication in *Out* is also a time.

The following example is for when *In1* is T#1d2h3m30s and *In2* is INT#2.

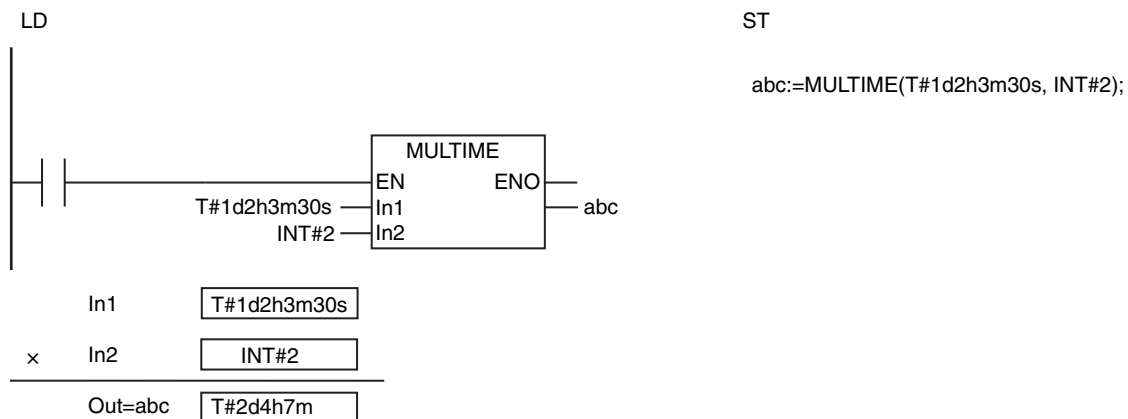

Precautions for Correct Use

- If *In2* is a real number, the multiplication result is rounded to the nearest nanosecond. The following table shows how values are rounded.

Value below nanoseconds	Treatment	Examples
Less than 0.5	The value is truncated.	1.49 → 1
0.5	If the ones digit is an even number, the value is truncated. If it is an odd number, the value is rounded up.	1.50 → 2 2.50 → 2
Greater than 0.5	The value is rounded up.	1.51 → 2

- If the value of *In2* is 0, positive infinity, negative infinity, or nonnumeric data, the value of *Out* is as shown below.

Value of <i>In2</i>	Value of <i>Out</i>	
	Other than the right	NX1P2
0	T#0s	T#0s
+∞	T#-106751d23h47m16.854775808s	T#-0d0h0m0s1e-6ms
-∞	T#-106751d23h47m16.854775808s	T#-0d0h0m0s1e-6ms
Nonnumeric data	T#-106751d23h47m16.854775808s	T#0s

- An error will not occur even if the multiplication result exceeds the valid range of *Out*.
 - T#53375d_23h_53m_38s_427.387904ms * USINT#2
→ T#-106751d_23h_47m_16s_854.775808ms
 - T#-53375d_23h_53m_38s_427.387905ms * USINT#2
→ T#106751d_23h_47m_16s_854.775806ms

DIVTIME

The DIVTIME instruction divides a time by a specified number.

Instruction	Name	FB/FUN	Graphic expression	ST expression
DIVTIME	Divide Time	FUN		Out:=DIVTIME(In1, In2);

Variables

Name	Meaning	I/O	Description	Valid range	Unit	Default
In1	Original time	Input	Original time	Depends on data type.	ns	T#0s
In2	Number to divide by		Number to divide by		---	*
Out	Resulting time	Output	Resulting time	Depends on data type.	ns	---

* If you omit the input parameter, the default value is not applied. A building error will occur.

	Boolean	Bit strings					Integers								Real numbers	Times, durations, dates, and text strings				
	BOOL	BYTE	WORD	DWORD	LWORD	USINT	UINT	UDINT	ULINT	SINT	INT	DINT	LINT	REAL	LREAL	TIME	DATE	TOD	DT	STRING
In1																OK				
In2						OK	OK	OK	OK	OK	OK	OK	OK	OK	OK					
Out																OK				

Function

The DIVTIME instruction divides a time *In1* by a number *In2*. The result of division in *Out* is also a time. The following example is for when *In1* is T#1d and *In2* is INT#2.

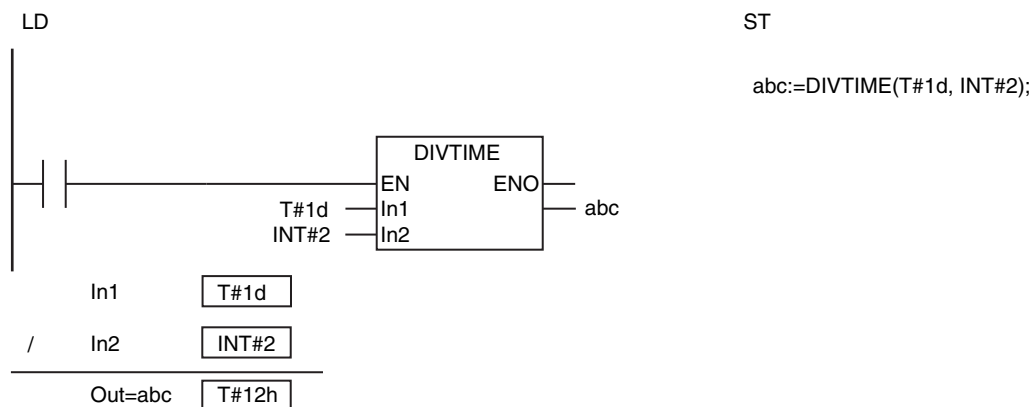

Precautions for Correct Use

- If the value of *In2* is 0, positive infinity, negative infinity, or nonnumeric data, the value of *Out* is as shown below.

Value of <i>In2</i>	Value of <i>Out</i>	
	Other than the right	NX1P2
0	T#-106751d23h47m16.854775808s	T#0d_0h_0m_0s_1e-006
$+\infty$	T#0s	T#0s
$-\infty$	T#0s	T#0s
Nonnumeric data	T#-106751d23h47m16.854775808s	T#0s

- If *In2* is a real number, there may be error of up to several nanoseconds.
- If *In2* is a real number, the division result is rounded to the nearest nanosecond. The following table shows how values are rounded.

Value below nanoseconds	Description	Example
Less than 0.5	The fractional part is truncated.	1.49 → 1
0.5	If the ones digit is an even number, the value is truncated. If it is an odd number, the value is rounded up.	1.50 → 2 2.50 → 2
Greater than 0.5	The fractional part is rounded up.	1.51 → 2

- An error occurs in the following case. *ENO* will be FALSE, and *Out* will not change.
 - In2* is an integer with a value of 0.

CONCAT_DATE_TOD

The CONCAT_DATE_TOD instruction combines a date and a time of day.

Instruction	Name	FB/FUN	Graphic expression	ST expression
CONCAT_DATE_TOD	Concatenate Date and Time of Day	FUN		Out:=CONCAT_DATE_TOD(In1, In2);

Variables

Name	Meaning	I/O	Description	Valid range	Unit	Default
In1	Date	Input	Date	Depends on data type.	Year, month, day	D#1970-1-1
In2	Time of day		Time of day		Hour, minutes, seconds	TOD#0:0:0
Out	Combined date and time	Output	Combined date and time	Depends on data type.	Year, month, day, hour, minutes, seconds	---

	Boolean	Bit strings					Integers							Real numbers		Times, durations, dates, and text strings				
	BOOL	BYTE	WORD	DWORD	LWORD	USINT	UINT	UDINT	ULINT	SINT	INT	DINT	LINT	REAL	LREAL	TIME	DATE	TOD	DT	STRING
In1																OK				
In2																	OK			
Out																		OK		

Function

The CONCAT_DATE_TOD instruction combines a date *In1* and a time of day *In2*. The result of combining in *Out* is also a date and time.

The following example is for when *In1* is D#1970-1-7 and *In2* is TOD#23:59:59.999999999.

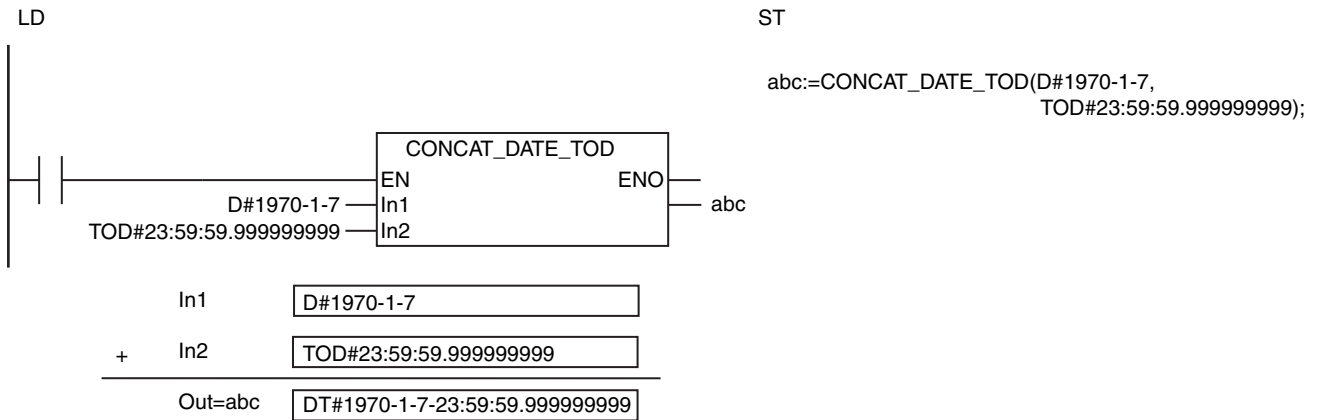

Related System-defined Variables

Name	Meaning	Data type	Description
_CurrentTime	System Time of Day	DT	The time of day from the system clock. The number of seconds from 00:00:00 on January 1, 1970.

Precautions for Correct Use

An error occurs in the following case. *ENO* will be FALSE, and *Out* will not change.

- The results of combining exceeds the valid range of *Out* (e.g., the value of *In1* is D#2554-7-21 and the value of *In2* is larger than TOD#23:34:33.709551615).

DT_TO_TOD

The DT_TO_TOD instruction extracts the time of day from a date and time.

Instruction	Name	FB/FUN	Graphic expression	ST expression
DT_TO_TOD	Extract Time of Day from Date and Time	FUN		Out:=DT_TO_TOD(In);

Variables

Name	Meaning	I/O	Description	Valid range	Unit	Default
In	Date and time	Input	Date and time	Depends on data type.	Year, month, day, hour, minutes, seconds	DT#1970-1-1-0:0:0
Out	Time of day	Output	Time of day	Depends on data type.	Hour, minutes, seconds	---

	Boolean	Bit strings					Integers							Real numbers	Times, durations, dates, and text strings					
	BOOL	BYTE	WORD	DWORD	LWORD	USINT	UINT	UDINT	ULINT	SINT	INT	DINT	LINT	REAL	LREAL	TIME	DATE	TOD	DT	STRING
In																			OK	
Out																		OK		

Function

The DT_TO_TOD instruction extracts the time of day from date and time *In*.

The following example is for when *In* is DT#1970-1-7-23:59:59.999999999.

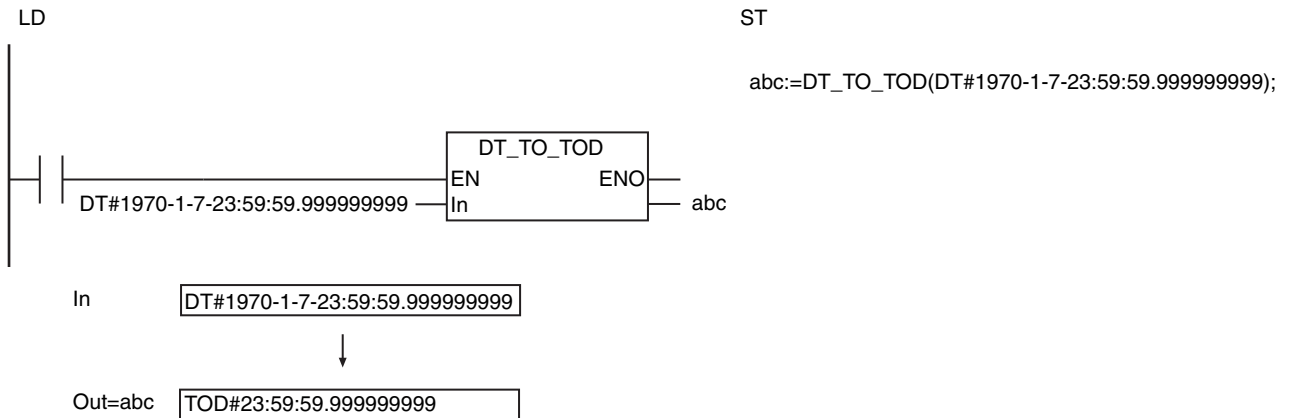

Related System-defined Variables

Name	Meaning	Data type	Description
_CurrentTime	System Time of Day	DT	The time of day from the system clock. The number of seconds from 00:00:00 on January 1, 1970.

DT_TO_DATE

The DT_TO_DATE instruction extracts the date from a date and time.

Instruction	Name	FB/FUN	Graphic expression	ST expression
DT_TO_DATE	Extract Date from Date and Time	FUN		Out:=DT_TO_DATE(In);

Variables

Name	Meaning	I/O	Description	Valid range	Unit	Default
In	Date and time	Input	Date and time	Depends on data type.	Year, month, day, hour, minutes, seconds	DT#1970-1-1-0:0:0
Out	Date	Output	Date	Depends on data type.	Year, month, day	---

	Boolean	Bit strings					Integers							Real numbers	Times, durations, dates, and text strings					
	BOOL	BYTE	WORD	DWORD	LWORD	USINT	UINT	UDINT	ULINT	SINT	INT	DINT	LINT	REAL	LREAL	TIME	DATE	TOD	DT	STRING
In																			OK	
Out																OK				

Function

The DT_TO_DATE instruction extracts the date from date and time *In*.

The following example is for when *In* is DT#1970-1-7-23:59:59.999999999.

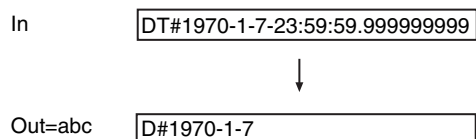
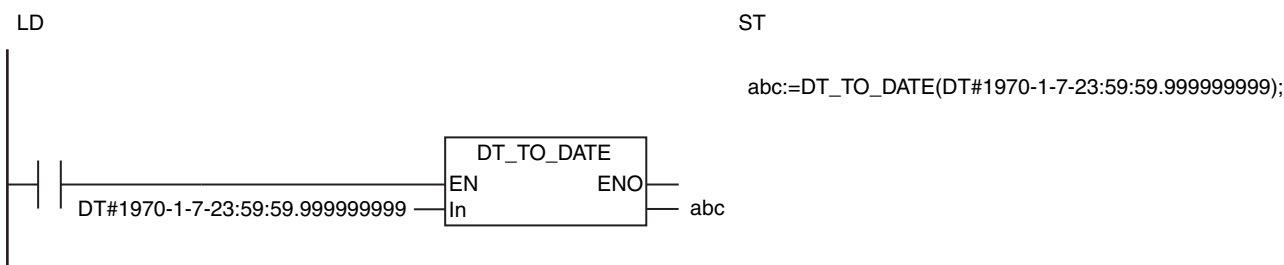

Related System-defined Variables

Name	Meaning	Data type	Description
_CurrentTime	System Time of Day	DT	The time of day from the system clock. The number of seconds from 00:00:00 on January 1, 1970.

SetTime

The SetTime instruction sets the system time.

Instruction	Name	FB/FUN	Graphic expression	ST expression
SetTime	Set Time	FUN		SetTime(In);

Variables

Name	Meaning	I/O	Description	Valid range	Unit	Default
In	Time data	Input	Current time to set system time	*1	Year, month, day, hour, minutes, seconds	DT#1970-1-1-0:0:0
Out	Return value	Output	Always TRUE	TRUE only	---	---

*1 The valid range is for any of the following GMTs (Greenwich Mean Times).
 The valid range for an NX-series CPU Unit is DT#1970-01-01-00:00:00.000000000 to DT#2069-12-31-23:59:59.999999999 (0:00:000000000 on January 1, 1970 to 23:59:59.999999999 on December 31, 2069).
 The valid range for an NJ-series CPU Unit is DT#1970-01-01-00:00:00.000000000 to DT#2106-02-06-23:59:59.999999999 (0:00:000000000 on January 1, 1970 to 23:59:59.999999999 on February 6, 2106).

	Boolean	Bit strings					Integers							Real numbers		Times, durations, dates, and text strings				
	BOOL	BYTE	WORD	DWORD	LWORD	USINT	UINT	UDINT	ULINT	SINT	INT	DINT	LINT	REAL	LREAL	TIME	DATE	TOD	DT	STRING
In																			OK	
Out	OK																			

Function

The SetTime instruction sets the system time to date and time *In*.

The following programming example is for when *In* is DT#1970-1-7:23:59:59.999999999.

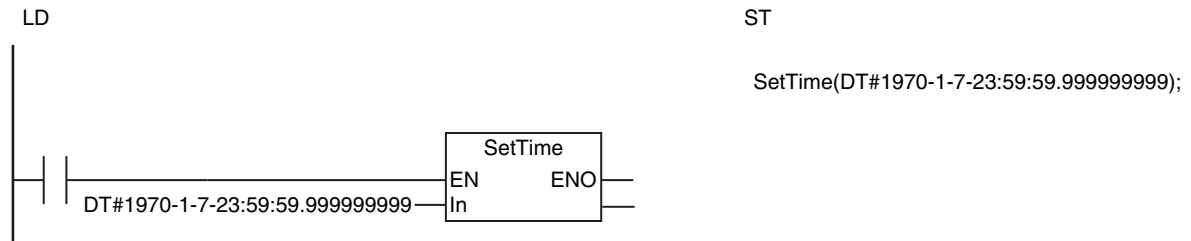

The SetTime instruction sets the value of *In* to the system time of day.

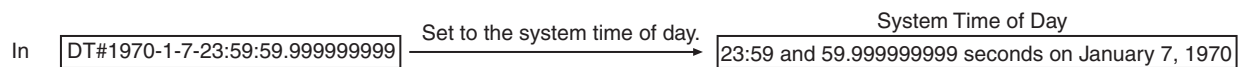

Related System-defined Variables

Name	Meaning	Data type	Description
_CurrentTime	System Time of Day	DT	The time of day from the system clock. The number of seconds from 00:00:00 on January 1, 1970.

Additional Information

The following methods can also be used to set the system time.

- Sysmac Studio
- NTP function

Precautions for Correct Use

- For *In*, specify the time for the set time zone (do not specify Greenwich mean time (GMT)).
- You cannot set a time in *In* that is lower than 1970-1-1-0:0:0.000000000 GMT.
- A time lag will occur when updating the internal time. If the time is read immediately after executing this instruction, the old time may be read.
- Return value *Out* is not used when the instruction is used in ST.
- An error occurs in the following cases. *ENO* will be FALSE, and *Out* will not change.
 - The value of *In* is outside of the valid range.
 - The value of *In* is below 1970-1-1-0:0:0.000000000 GMT.

GetTime

The GetTime instruction reads the current time.

Instruction	Name	FB/FUN	Graphic expression	ST expression
GetTime	Get Time of Day	FUN		Out:=GetTime();

Variables

Name	Meaning	I/O	Description	Valid range	Unit	Default
Out	Current time	Output	Current time	*	Year, month, day, hour, minutes, seconds	---

* The valid range is for any of the following GMTs (Greenwich Mean Times).
 The valid range for an NX-series CPU Unit is DT#1970-01-01-00:00:00.000000000 to DT#2069-12-31-23:59:59.999999999 (0:00:000000000 on January 1, 1970 to 23:59:59.999999999 on December 31, 2069).
 The valid range for an NJ-series CPU Unit is DT#1970-01-01-00:00:00.000000000 to DT#2106-02-06-23:59:59.999999999 (0:00:000000000 on January 1, 1970 to 23:59:59.999999999 on February 6, 2106).
 The valid range for an NY-series Controller is DT#2000-01-01-00:00:00.000000000 to DT#2099-12-31-23:59:59.999999999 (00:00:00.000000000 on January 1, 2000 to 23:59:59.999999999 on December 31, 2099).

	Boolean	Bit strings					Integers							Real numbers		Times, durations, dates, and text strings				
	BOOL	BYTE	WORD	DWORD	LWORD	USINT	UINT	UDINT	ULINT	SINT	INT	DINT	LINT	REAL	LREAL	TIME	DATE	TOD	DT	STRING
Out																			OK	

Function

The GetTime instruction reads the current time. The current time of day is the time for the set time zone (not Greenwich mean time (GMT)).

The following figure shows a programming example. The current time is assigned to variable *abc*.

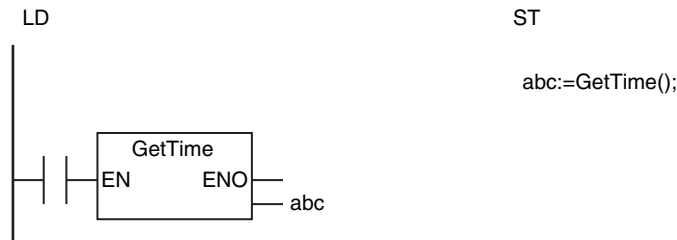

The GetTime instruction assigns the current time to *abc*.

For 23:59 and 59.999999999 seconds on January 7, 1970

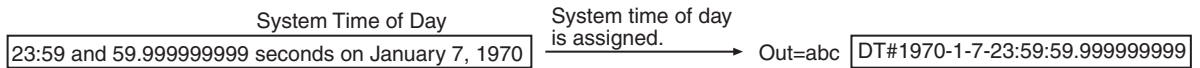

Related System-defined Variables

Name	Meaning	Data type	Description
_CurrentTime	System Time of Day	DT	The time of day from the system clock. The number of seconds from 00:00:00 on January 1, 1970.

Additional Information

- Use the DtToSec instruction (page 2-624) to convert the current time of day to the system time of day (number of seconds from 00:00:00 on January 1, 1970).
- Use the DtToDateStruct instruction (page 2-648) to convert the current time of day to a date (year, month, day, minutes, and seconds).
- Use the GetDayOfWeek instruction (page 2-644) to read the day of the week.

DtToSec

The DtToSec instruction converts a date and time to the number of seconds from 00:00:00 on January 1, 1970.

Instruction	Name	FB/FUN	Graphic expression	ST expression
DtToSec	Convert Date and Time to Seconds	FUN		Out:=DtToSec(In);

Variables

Name	Meaning	I/O	Description	Valid range	Unit	Default
In	Date and time	Input	Date and time	Depends on data type.	Year, month, day, hour, minutes, seconds	DT#1970-1-1-0:0:0
Out	Seconds	Output	Number of seconds from 00:00:00 on January 1, 1970	0 to 18446744073	Seconds	---

	Boolean	Bit strings					Integers							Real numbers	Times, durations, dates, and text strings					
	BOOL	BYTE	WORD	DWORD	LWORD	USINT	UINT	UDINT	ULINT	SINT	INT	DINT	LINT	REAL	LREAL	TIME	DATE	TOD	DT	STRING
In																			OK	
Out													OK							

Function

The DtToSec instruction converts the date and time in *In* to the number of seconds from 00:00:00 on January 1, 1970. The converted value is in seconds. The value is truncated below the seconds.

The following example is for when *In* is DT#1970-1-2-0:0:0.999999999.

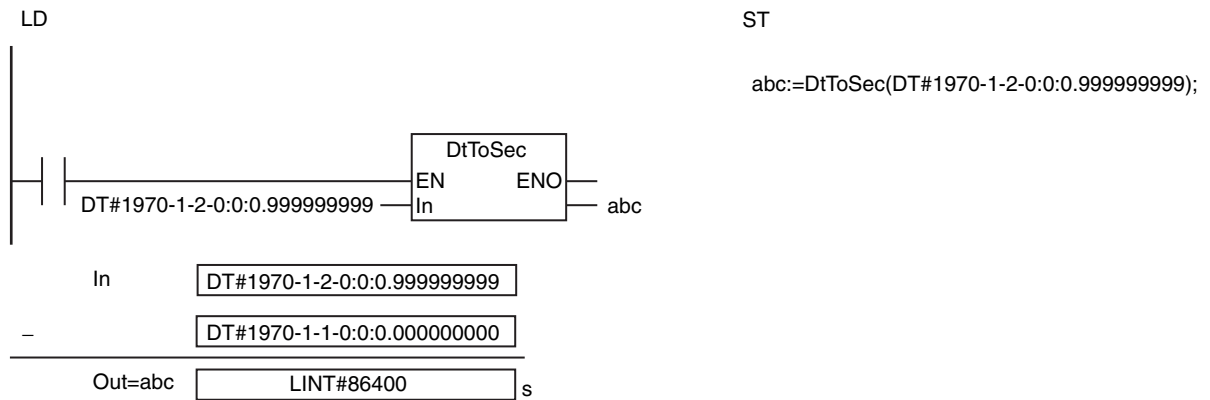

Related System-defined Variables

Name	Meaning	Data type	Description
_CurrentTime	System Time of Day	DT	The time of day from the system clock. The number of seconds from 00:00:00 on January 1, 1970.

Additional Information

Use the SecToDt instruction (page 2-628) to convert the number of seconds from 00:00:00 on January 1, 1970 to a date and time.

DateToSec

The DateToSec instruction converts a date to the number of seconds from 00:00:00 on January 1, 1970.

Instruction	Name	FB/FUN	Graphic expression	ST expression
DateToSec	Convert Date to Seconds	FUN		Out:=DateToSec(In);

Variables

Name	Meaning	I/O	Description	Valid range	Unit	Default
In	Date	Input	Date	Depends on data type.	Year, month, day	DT#1970-1-1
Out	Seconds	Output	Number of seconds from 00:00:00 on January 1, 1970	0 to 18446659200	Seconds	---

	Boolean	Bit strings					Integers							Real numbers	Times, durations, dates, and text strings						
		BOOL	BYTE	WORD	DWORD	LWORD	USINT	UINT	UDINT	ULINT	SINT	INT	DINT		LINT	REAL	LREAL	TIME	DATE	TOD	DT
In																	OK				
Out													OK								

Function

The DateToSec instruction converts 00:00:00 on date *In* to the number of seconds from 00:00:00 on January 1, 1970. The converted value is in seconds.

The following example is for when *In* is D#1970-1-2.

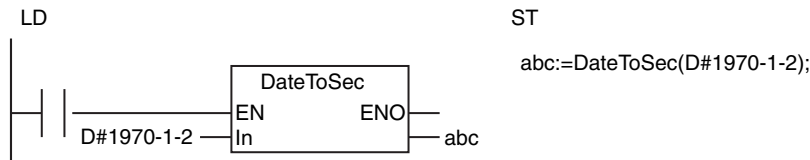

In	D#1970-1-2
—	DT#1970-1-1-0:0:0.000000000
Out=abc	LINT#86400 s

Additional Information

Use the SecToDate instruction (page 2-630) to convert the number of seconds from 00:00:00 on January 1, 1970 to a date.

TodToSec

The TodToSec instruction converts a time of day to the number of seconds from 00:00:00.

Instruction	Name	FB/FUN	Graphic expression	ST expression
TodToSec	Convert Time of Day to Seconds	FUN		Out:=TodToSec(In);

Variables

Name	Meaning	I/O	Description	Valid range	Unit	Default
In	Time of day	Input	Time of day	Depends on data type.	Hour, minutes, seconds	TOD#0:0:0
Out	Seconds	Output	Number of seconds from 00:00:00	0 to 86399	Seconds	---

	Boolean	Bit strings				Integers								Real numbers		Times, durations, dates, and text strings					
		BOOL	BYTE	WORD	DWORD	LWORD	USINT	UINT	UDINT	ULINT	SINT	INT	DINT	LINT	REAL	LREAL	TIME	DATE	TOD	DT	STRING
In																			OK		
Out													OK								

Function

The TodToSec instruction converts the time of day in *In* to the number of seconds from 00:00:00. The converted value is in seconds. The value is truncated below the seconds.

The following example is for when *In* is TOD#12:0:0.999999999.

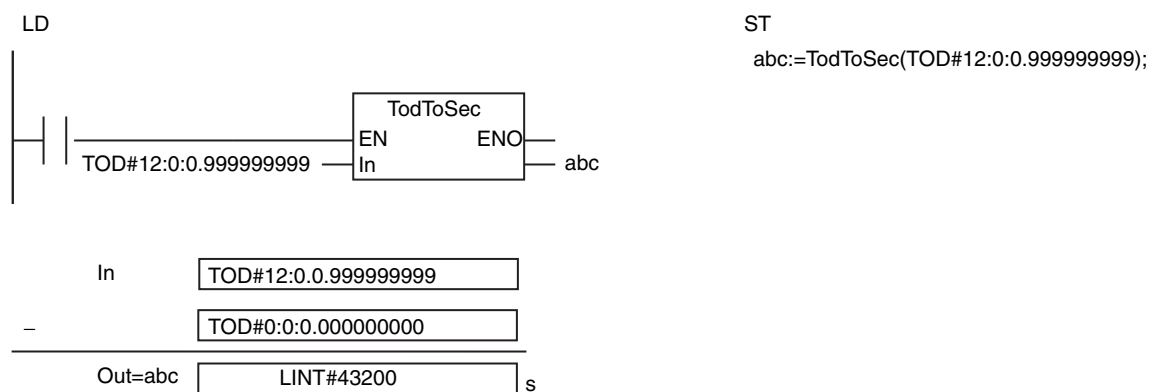

Additional Information

Use the SecToTod instruction (page 2-632) to convert the number of seconds from 00:00:00 on January 1, 1970 to a time of day.

SecToDt

The SecToDt instruction converts the number of seconds from 00:00:00 on January 1, 1970 to a date and time.

Instruction	Name	FB/FUN	Graphic expression	ST expression
SecToDt	Convert Seconds to Date and Time	FUN	<pre> (@)SecToDt -- EN ENO -- In Out </pre>	Out:=SecToDt(In);

Variables

Name	Meaning	I/O	Description	Valid range	Unit	Default
In	Seconds	Input	Number of seconds from 00:00:00 on January 1, 1970	0 to 18446744073	Seconds	0
Out	Date and time	Output	Date and time	Depends on data type.	Year, month, day, hour, minutes, seconds	---

	Boolean	Bit strings					Integers							Real numbers		Times, durations, dates, and text strings				
	BOOL	BYTE	WORD	DWORD	LWORD	USINT	UINT	UDINT	ULINT	SINT	INT	DINT	LINT	REAL	LREAL	TIME	DATE	TOD	DT	STRING
In													OK							
Out																			OK	

Function

The SecToDt instruction converts the number of seconds from 00:00:00 on January 1, 1970 in *In* to a date and time.

The following example is for when *In* is LINT#86400.

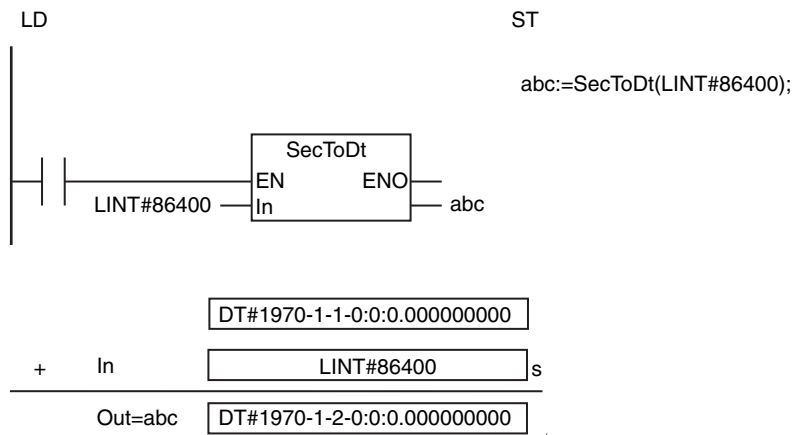

Related System-defined Variables

Name	Meaning	Data type	Description
_CurrentTime	System Time of Day	DT	The time of day from the system clock. The number of seconds from 00:00:00 on January 1, 1970.

Additional Information

Use the DtToSec instruction (page 2-624) to convert the current time of day to the number of seconds from 00:00:00 on January 1, 1970.

Precautions for Correct Use

An error occurs in the following case. *ENO* will be FALSE, and *Out* will not change.

- The value of *In* is outside of the valid range.

Precautions for Correct Use

An error occurs in the following case. *ENO* will be FALSE, and *Out* will not change.

- The value of *In* is outside of the valid range.

SecToTod

The SecToTod instruction converts the number of seconds from 00:00:00 to a time of day.

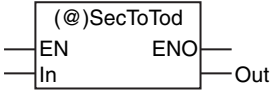
Instruction	Name	FB/FUN	Graphic expression	ST expression
SecToTod	Convert Seconds to Time of Day	FUN		Out:=SecToTod(In);

Variables

Name	Meaning	I/O	Description	Valid range	Unit	Default
In	Seconds	Input	Number of seconds from 00:00:00	Depends on data type.*	Seconds	0
Out	Time of day	Output	Time of day	Depends on data type.	Hour, minutes, seconds	---

* Negative numbers are excluded.

	Boolean	Bit strings					Integers							Real numbers	Times, durations, dates, and text strings								
		BOOL	BYTE	WORD	DWORD	LWORD	USINT	UINT	UDINT	ULINT	SINT	INT	DINT		LINT	REAL	LREAL	TIME	DATE	TOD	DT	STRING	
In														OK									
Out																			OK				

Function

The SecToTod instruction converts the number of seconds from 00:00:00 in *In* to a time of day. If the value of *In* is 24 hours or longer, *In* is divided by 24 and the remainder is converted to the time of day. The following example is for when *In* is LINT#86410.

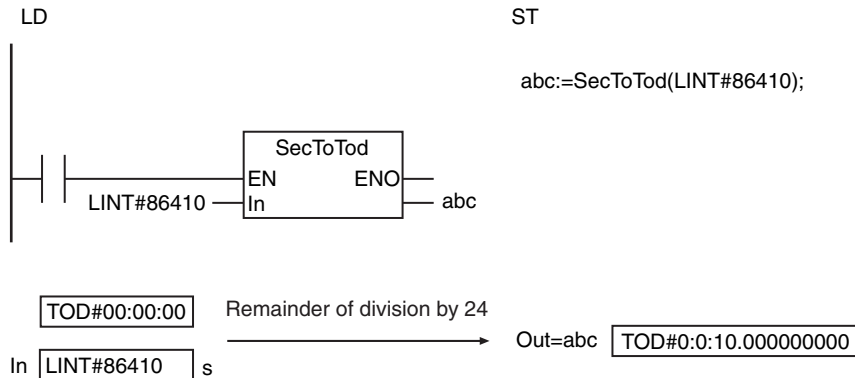

Additional Information

Use the TodToSec instruction (page 2-627) to convert a time of day to the number of seconds from 00:00:00 on January 1, 1970.

Precautions for Correct Use

An error occurs in the following case. *ENO* will be FALSE, and *Out* will not change.

- The value of *In* is outside of the valid range.

TimeToNanoSec

The TimeToNanoSec instruction converts a time to nanoseconds.

Instruction	Name	FB/FUN	Graphic expression	ST expression
TimeToNanoSec	Convert Time to Nanoseconds	FUN		Out:=TimeToNanoSec(In);

Variables

Name	Meaning	I/O	Description	Valid range	Unit	Default
In	Time	Input	Time	Depends on data type.	ns	T#0s
Out	Nanoseconds	Output	Nanoseconds	*	ns	---

* -9223372036854775808 to 9223372036854775807

	Boolean	Bit strings					Integers							Real numbers	Times, durations, dates, and text strings					
	BOOL	BYTE	WORD	DWORD	LWORD	USINT	UINT	UDINT	ULINT	SINT	INT	DINT	LINT	REAL	LREAL	TIME	DATE	TOD	DT	STRING
In																OK				
Out													OK							

Function

The TimeToNanoSec instruction converts the time in *In* to nanoseconds.

The following example is for when *In* is T#1d1h1m1.999999999s.

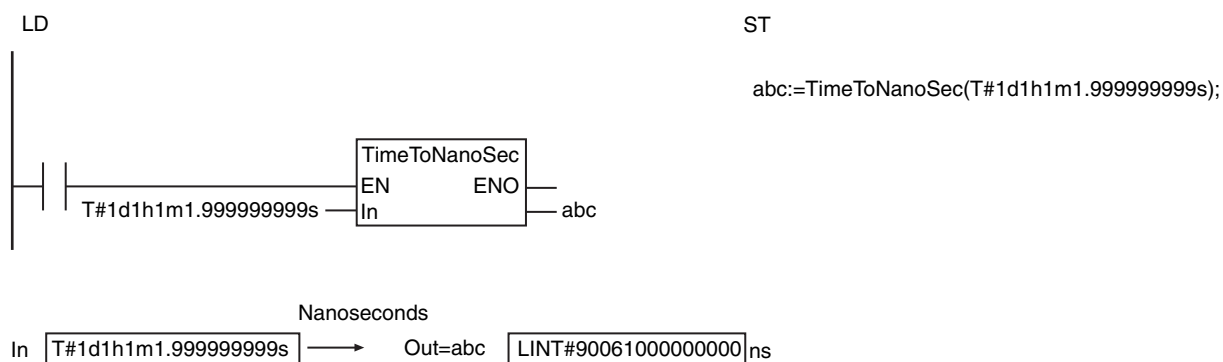

Additional Information

Use the NanoSecToTime instruction (page 2-636) to convert nanoseconds to a time.

TimeToSec

The TimeToSec instruction converts a time to seconds.

Instruction	Name	FB/FUN	Graphic expression	ST expression
TimeToSec	Convert Time to Seconds	FUN		Out:=TimeToSec(In);

Variables

Name	Meaning	I/O	Description	Valid range	Unit	Default
In	Time	Input	Time	Depends on data type.	ns	T#0s
Out	Seconds	Output	Seconds	-9223372036 to 9223372036	Seconds	---

	Boolean	Bit strings					Integers							Real numbers	Times, durations, dates, and text strings					
	BOOL	BYTE	WORD	DWORD	LWORD	USINT	UINT	UDINT	ULINT	SINT	INT	DINT	LINT	REAL	LREAL	TIME	DATE	TOD	DT	STRING
In																OK				
Out							OK													

Function

The TimeToSec instruction converts the time in *In* to seconds. The value is truncated below the seconds.

The following example is for when *In* is T#1d1h1m1.999999999s.

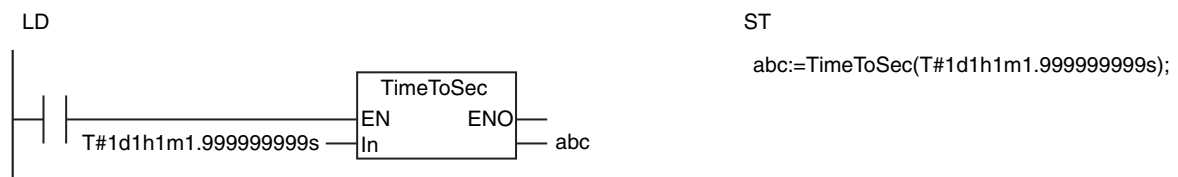

Additional Information

Use the SecToTime instruction (page 2-637) to convert seconds to a time.

Precautions for Correct Use

In is in nanoseconds. *Out* is in seconds.

NanoSecToTime

The NanoSecToTime instruction converts nanoseconds to a time.

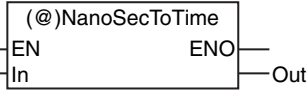
Instruction	Name	FB/FUN	Graphic expression	ST expression
NanoSecToTime	Convert Nanoseconds to Time	FUN		Out:=NanoSecToTime(In);

Variables

Name	Meaning	I/O	Description	Valid range	Unit	Default
In	Nanoseconds	Input	Nanoseconds	*	ns	0
Out	Time	Output	Time	Depends on data type.	ns	---

* -9223372036854775808 to 9223372036854775807

	Boolean	Bit strings					Integers							Real numbers	Times, durations, dates, and text strings					
	BOOL	BYTE	WORD	DWORD	LWORD	USINT	UINT	UDINT	ULINT	SINT	INT	DINT	LINT	REAL	LREAL	TIME	DATE	TOD	DT	STRING
In													OK							
Out																OK				

Function

The NanoSecToTime instruction converts the number of nanoseconds in *In* to a time.

The following example is for when *In* is LINT#90061000000000.

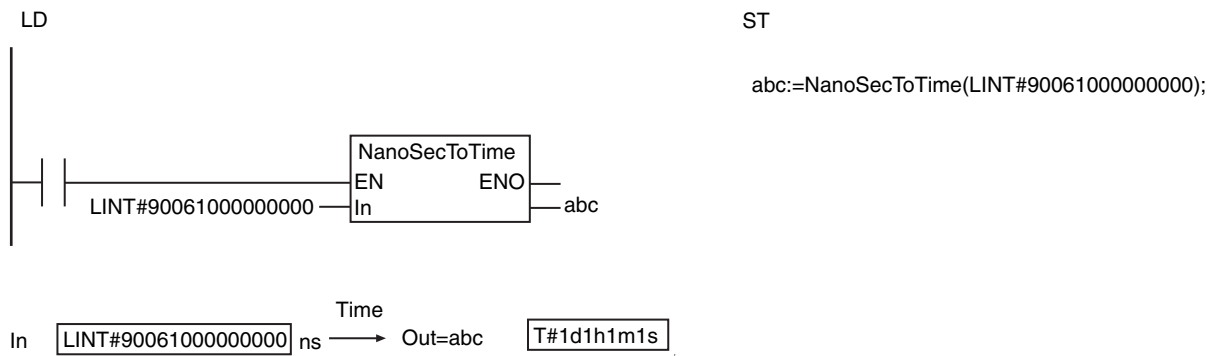

Additional Information

Use the TimeToNanoSec instruction (page 2-634) to convert a time to nanoseconds.

SecToTime

The SecToTime instruction converts seconds to a time.

Instruction	Name	FB/FUN	Graphic expression	ST expression
SecToTime	Convert Seconds to Time	FUN		Out:=SecToTime(In);

Variables

Name	Meaning	I/O	Description	Valid range	Unit	Default
In	Seconds	Input	Seconds	-9223372036 to 9223372036	Seconds	0
Out	Time	Output	Time	Depends on data type.	ns	---

	Boolean	Bit strings				Integers							Real numbers	Times, durations, dates, and text strings								
		BOOL	BYTE	WORD	DWORD	LWORD	USINT	UINT	UDINT	ULINT	SINT	INT		DINT	LINT	REAL	LREAL	TIME	DATE	TOD	DT	STRING
In														OK								
Out																OK						

Function

The SecToTime instruction converts the number of seconds in *In* to a time. The following example is for when *In* is LINT#90061.

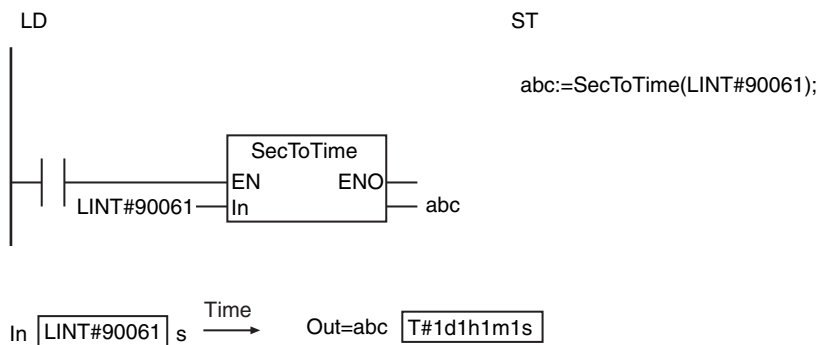

Additional Information

Use the TimeToSec instruction (page 2-635) to convert a time to seconds.

Precautions for Correct Use

- *In* is in seconds. *Out* is in nanoseconds.
- An error occurs in the following case. *ENO* will be FALSE, and *Out* will not change.
 - The value of *In* is outside of the valid range.

GetDaysOfMonth

The GetDaysOfMonth instruction gets the number of days in the specified month.

Instruction	Name	FB/FUN	Graphic expression	ST expression
GetDaysOfMonth	Get Days in Month	FUN		Out:=GetDaysOfMonth(Year, Month);

Variables

Name	Meaning	I/O	Description	Valid range	Unit	Default
Year	Year	Input	Year	1970 to 2554	Year	1970
Month	Month		Month	1 to 12	Month	1
Out	Days	Output	Days	28 to 31	Days	---

	Boolean	Bit strings					Integers							Real numbers		Times, durations, dates, and text strings					
		BOOL	BYTE	WORD	DWORD	LWORD	USINT	UINT	UDINT	ULINT	SINT	INT	DINT	LINT	REAL	LREAL	TIME	DATE	TOD	DT	STRING
Year							OK														
Month						OK															
Out						OK															

Function

The GetDaysOfMonth instruction gets the number of days in month *Month* of year *Year*.

The following example is for when *Year* is UINT#2012 and *Month* is USINT#2.

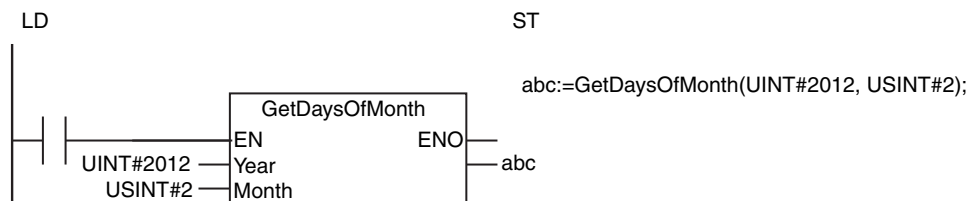

Precautions for Correct Use

- If the value of *Year* exceeds the valid range, an error will not occur and the value of *Out* will be an illegal value.
- An error occurs in the following case. *ENO* will be FALSE, and *Out* will not change.
 - The value of *Month* is outside of the valid range.

Sample Programming

This sample gets the number of days in the current month.

LD

Internal Variables	Variable	Data type	Initial value	Comment
	abc	_sDT	(Year:=0, Month:=0, Day:=0, Hour:=0, Min:=0, Sec:=0, NSec:=0)	Date and time
	def	USINT	0	Days in current month

External Variables	Variable	Data type	Constant	Comment
	_CurrentTime	DATE_AND_TIME	✓	System Time of Day

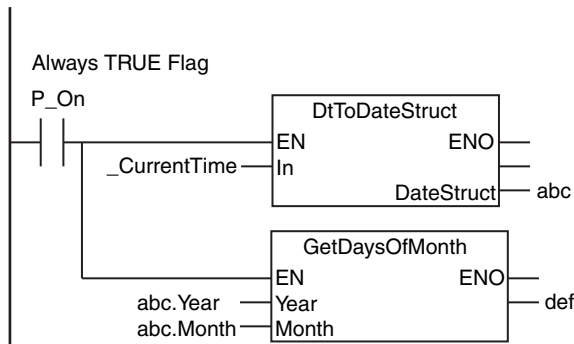

ST

Internal Variables	Variable	Data type	Initial value	Comment
	abc	_sDT	(Year:=0, Month:=0, Day:=0, Hour:=0, Min:=0, Sec:=0, NSec:=0)	Date and time
	def	USINT	0	Days in current month

External Variables	Variable	Data type	Constant	Comment
	_CurrentTime	DATE_AND_TIME	✓	System Time of Day

```
DtToDateStruct(_CurrentTime, abc);
def:=GetDaysOfMonth(abc.Year, abc.Month);
```

DaysToMonth

The DaysToMonth instruction calculates the month based on the number of days from January 1.

Instruction	Name	FB/FUN	Graphic expression	ST expression
DaysToMonth	Convert Days to Month	FUN		Out:=DaysToMonth(Year, Days);

Variables

Name	Meaning	I/O	Description	Valid range	Unit	Default
Year	Year	Input	Year	1970 to 2554	Year	1970
Days	Days		Number of days from January 1	1 to 365 1 to 366 for a leap year	Days	1
Out	Month	Output	Month	1 to 12	Month	---

	Boolean	Bit strings					Integers						Real numbers	Times, durations, dates, and text strings						
	BOOL	BYTE	WORD	DWORD	LWORD	USINT	UINT	UDINT	ULINT	SINT	INT	DINT	LINT	REAL	LREAL	TIME	DATE	TOD	DT	STRING
Year							OK													
Days							OK													
Out						OK														

Function

The DaysToMonth instruction calculates the month based on the number of days in *Days* from January 1 in year *Year*.

The following example is for when *Year* is UINT#2012 and *Days* is UINT#32.

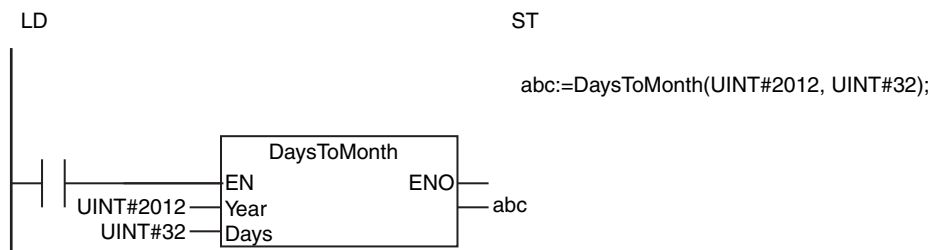

Precautions for Correct Use

- If the value of *Year* exceeds the valid range, an error will not occur and the value of *Out* will be an illegal value.
- An error occurs in the following case. *ENO* will be FALSE, and *Out* will not change.
 - The value of *Days* is outside of the valid range.

GetDayOfWeek

The GetDayOfWeek instruction gets the day of the week for the specified year, month, and day of month.

Instruction	Name	FB/FUN	Graphic expression	ST expression
GetDayOfWeek	Get Day of Week	FUN		Out:=GetDayOfWeek(In);

Variables

Name	Meaning	I/O	Description	Valid range	Unit	Default
In	Year, month, day	Input	Year, month, day	Depends on data type.	Year, month, day	*
Out	Day of the week	Output	Day of the week	_MON, _TUE, _WED, _THU, _FRI, _SAT, _SUN	Day of the week	---

* If you omit the input parameter, the default value is not applied. A building error will occur.

	Boolean	Bit strings					Integers							Real numbers	Times, durations, dates, and text strings					
	BOOL	BYTE	WORD	DWORD	LWORD	USINT	UINT	UDINT	ULINT	SINT	INT	DINT	LINT	REAL	LREAL	TIME	DATE	TOD	DT	STRING
In																OK			OK	
Out		Refer to <i>Function</i> for the enumerators for the enumerated type _eDAYOFWEEK.																		

Function

The GetDayOfWeek instruction gets the day of the week for the year, month, and day of month specified in *In*.

The data type of *Out* is enumerated type _eDAYOFWEEK. The meanings of the enumerators are as follows:

Enumerator	Meaning
_MON	Monday
_TUE	Tuesday
_WED	Wednesday
_THU	Thursday
_FRI	Friday
_SAT	Saturday
_SUN	Sunday

The following example is for when *In* is D#2011-1-1.

LD

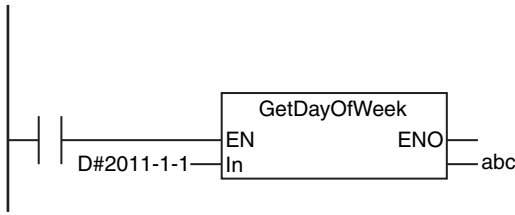

ST

```
abc:=GetDayOfWeek(D#2011-1-1);
```

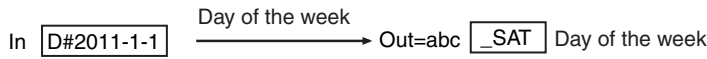

Related System-defined Variables

Name	Meaning	Data type	Description
_CurrentTime	System Time of Day	DT	The time of day from the system clock. The number of seconds from 00:00:00 on January 1,1970.

GetWeekOfYear

The GetWeekOfYear instruction gets the week number for the specified year, month, and day of month.

Instruction	Name	FB/FUN	Graphic expression	ST expression
GetWeekOfYear	Get Week Number	FUN		Out:=GetWeekOfYear(In);

Variables

Name	Meaning	I/O	Description	Valid range	Unit	Default
In	Year, month, day	Input	Year, month, day	Depends on data type.	Year, month, day	*
Out	Week	Output	Week number	1 to 54	Week	---

* If you omit the input parameter, the default value is not applied. A building error will occur.

	Boolean	Bit strings					Integers							Real numbers		Times, durations, dates, and text strings				
	BOOL	BYTE	WORD	DWORD	LWORD	USINT	UINT	UDINT	ULINT	SINT	INT	DINT	LINT	REAL	LREAL	TIME	DATE	TOD	DT	STRING
In																OK			OK	
Out						OK														

Function

The GetWeekOfYear instruction gets the week number for the year, month, and day of month specified in *In*. Weeks are counted from Monday to Sunday. The count is incremented when changing from Sunday to Monday.

January 1 is always in week 1. For example, if January 1 is a Thursday, January 1 to January 4 (Sunday) is week 1 and January 5 (Monday) to January 11 (Sunday) is week 2.

The following example is for when *In* is D#2011-2-1.

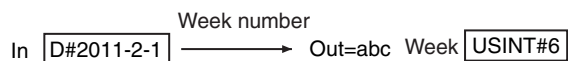
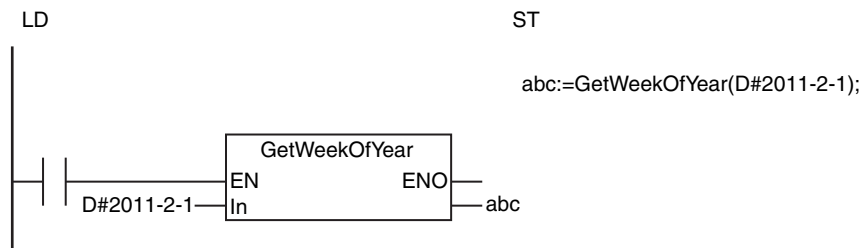

Related System-defined Variables

Name	Meaning	Data type	Description
_CurrentTime	System Time of Day	DT	The time of day from the system clock. The number of seconds from 00:00:00 on January 1, 1970.

DtToDateStruct

The DtToDateStruct instruction converts a date and time to the year, month, day, hour, minutes, seconds, and nanoseconds.

Instruction	Name	FB/FUN	Graphic expression	ST expression
DtToDateStruct	Break Down Date and Time	FUN		Out:=DtToDateStruct(In, DateStruct);

Variables

Name	Meaning	I/O	Description	Valid range	Unit	Default
In	Date and time	Input	Date and time	Depends on data type.	Year, month, day, hour, minutes, seconds	DT#1970-1-1-0:0:0
Out	Return value	Output	Always TRUE	TRUE only		
DateStruct	Date and time		Date and time as a year, month, day, hour, minutes, seconds, and nanoseconds	---	---	---

	Boolean	Bit strings					Integers							Real numbers		Times, durations, dates, and text strings				
	BOOL	BYTE	WORD	DWORD	LWORD	USINT	UINT	UDINT	ULINT	SINT	INT	DINT	LINT	REAL	LREAL	TIME	DATE	TOD	DT	STRING
In																			OK	
Out	OK																			
DateStruct	Refer to <i>Function</i> for details on the structure <code>_sDT</code> .																			

Function

The DtToDateStruct instruction converts the date and time in *In* to the year, month, day, hour, minutes, seconds, and nanoseconds. The data in the broken down date and time in *Out* is the structure `_sDT`. The meanings of the members are as follows:

Name	Meaning	Content	Data type	Valid range	Unit	Default
Out	Date and time	Date and time as a year, month, day, hour, minutes, seconds, and nanoseconds	<code>_sDT</code>	---	---	---
Year	Year	Year	UINT	1970 to 2554	Year	---
Month	Month	Month	USINT	1 to 12	Month	
Day	Day	Day	USINT	1 to 31	Day	
Hour	Hour	Hour	USINT	0 to 23	Hour	
Min	Minutes	Minutes	USINT	0 to 59	Minutes	
Sec	Seconds	Seconds	USINT	0 to 59	Seconds	
Nsec	Nanoseconds	Nanoseconds	ULINT	0 to 999999999	Nanoseconds	

The following example is for when *In* is DT#1970-1-2-12:34:56.999999999.

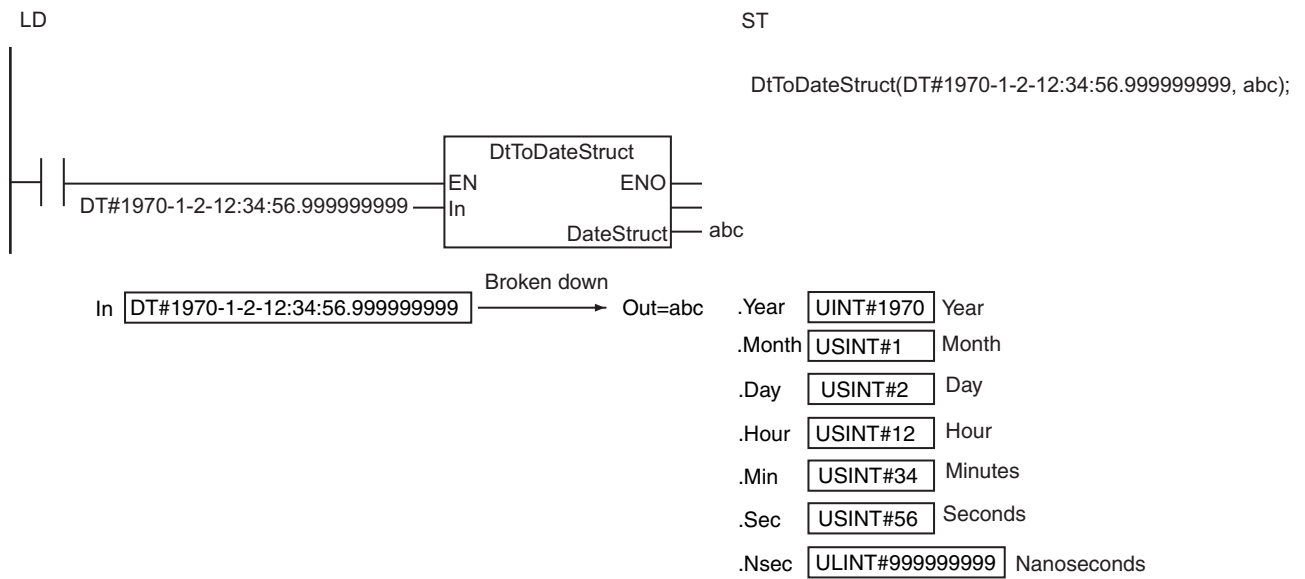

Related System-defined Variables

Name	Meaning	Data type	Description
_CurrentTime	System Time of Day	DT	The time of day from the system clock. The number of seconds from 00:00:00 on January 1,1970.

Additional Information

- Use the DateStructToDt instruction (page 2-650) to join a year, month, day, hour, minutes, seconds, and nanoseconds into a date and time.
- The following example shows how to find the current time of day.

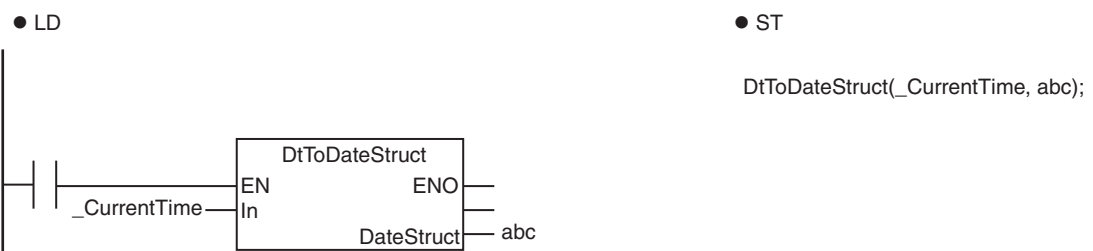

Precautions for Correct Use

Return value *Out* is not used when the instruction is used in ST.

DateStructToDt

The DateStructToDt instruction joins a year, month, day, hour, minutes, seconds, and nanoseconds into a date and time.

Instruction	Name	FB/FUN	Graphic expression	ST expression
DateStructToDt	Join Time	FUN		Out:=DateStructToDt(In);

Variables

Name	Meaning	I/O	Description	Valid range	Unit	Default
In	Date and time	Input	Date and time as a year, month, day, hour, minutes, seconds, and nanoseconds	---	---	---
Out	Date and time	Output	Date and time	Depends on data type.	Year, month, day, hour, minutes, seconds	---

	Boolean	Bit strings					Integers						Real numbers	Times, durations, dates, and text strings						
	BOOL	BYTE	WORD	DWORD	LWORD	USINT	UINT	UDINT	ULINT	SINT	INT	DINT	LINT	REAL	LREAL	TIME	DATE	TOD	DT	STRING
In																				
Out																				OK

Function

The DateStructToDt instruction joins the year, month, day, hour, minutes, seconds, and nanoseconds in *In* into a date and time. The data type of *In* is structure *_sDT*. The meanings of the members are as follows:

Name	Meaning	Content	Data type	Valid range	Unit	Default
In	Date and time	Date and time as a year, month, day, hour, minutes, seconds, and nanoseconds	<i>_sDT</i>	---	---	---
Year	Year	Year	UINT	1970 to 2554	Year	1970
Month	Month	Month	USINT	1 to 12	Month	1
Day	Day	Day	USINT	1 to 31	Day	
Hour	Hour	Hour	USINT	0 to 23	Hour	
Min	Minutes	Minutes	USINT	0 to 59	Minutes	
Sec	Seconds	Seconds	USINT	0 to 59	Seconds	
Nsec	Nanoseconds	Nanoseconds	ULINT	0 to 999999999	Nanoseconds	0

The following example is for the following values for the members of *In*: *Year* is UINT#1970, *Month* is USINT#1, *Day* is USINT#2, *Hour* is USINT#12, *Min* is USINT#34, *Sec* is USINT#56, and *Nsec* is ULINT#999999999.

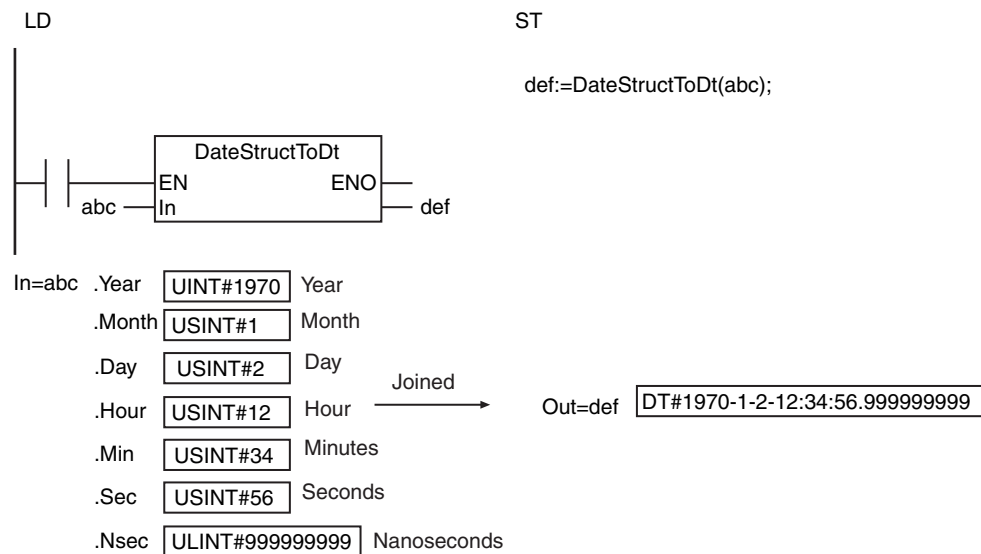

Related System-defined Variables

Name	Meaning	Data type	Description
_currentTime	System Time of Day	DT	The time of day from the system clock. The number of seconds from 00:00:00 on January 1, 1970.

Additional Information

Use the DtToDateStruct instruction (page 2-648) to break down a date and time into a year, month, day, hour, minutes, seconds, and nanoseconds.

Precautions for Correct Use

An error occurs in the following cases. *ENO* will be FALSE, and *Out* will not change.

- The value of a member of *In* is outside of the valid range.
- The processing result exceeds the valid range of *Out*.

TruncTime

The TruncTime instruction truncates a TIME variable below the specified time unit.

Instruction	Name	FB/FUN	Graphic expression	ST expression
TruncTime	Truncate Time	FUN		Out:=TruncTime(In, Accuracy);

Variables

Name	Meaning	I/O	Description	Valid range	Unit	Default
In	Time to truncate	Input	Time to truncate	Depends on data type.	ns	T#0s
Accuracy	Smallest unit after truncation		The smallest time unit to leave after truncation	_NANOSEC, _MICROSEC, _MILLISEC, _SEC	---	_NANO-SEC
Out	Time after truncation	Output	Time after truncation	Depends on data type.	ns	---

	Boolean	Bit strings					Integers							Real numbers	Times, durations, dates, and text strings					
	BOOL	BYTE	WORD	DWORD	LWORD	USINT	UINT	UDINT	ULINT	SINT	INT	DINT	LINT	REAL	LREAL	TIME	DATE	TOD	DT	STRING
In																OK				
Accuracy	Refer to <i>Function</i> for the enumerators of enumeration type _eSUBSEC.																			
Out																OK				

Function

The TruncTime instruction truncates all digits below the smallest unit after truncation that is specified in *Accuracy* from the time to truncate in *In*. The resulting time after truncation is stored in time after truncation *Out*.

The data type of *Accuracy* is enumerated type _eSUBSEC. The meanings of the enumerators are as follows:

Enumerator	Meaning
_NANOSEC	Nanoseconds
_MICROSEC	Microseconds
_MILLISEC	Milliseconds
_SEC	Seconds

The following example is for when *In* is TIME#123.456789012s and *Accuracy* is _MICROSEC.

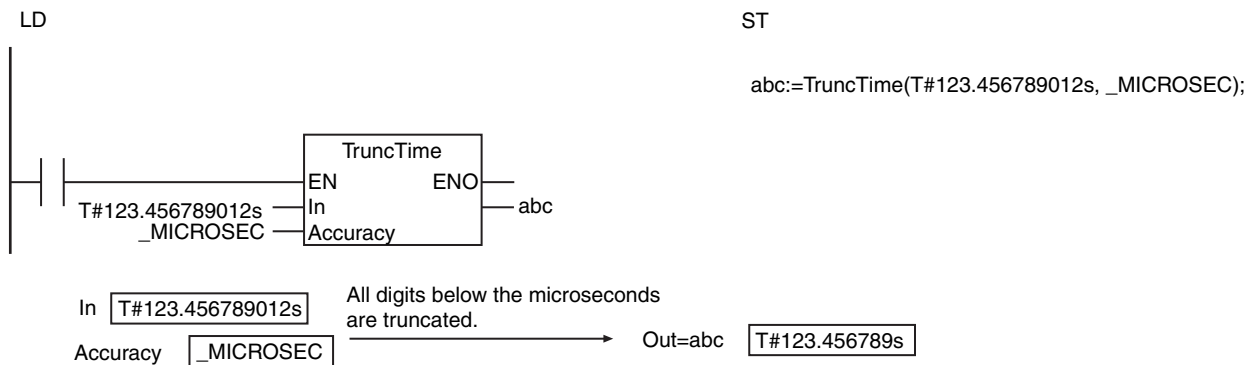

Additional Information

Before you compare two TIME variables with the EQ (=) instruction (page 2-92) or other instructions, use the TruncTime instruction to convert the two variables to the same accuracy.

Precautions for Correct Use



Version Information

A CPU Unit with unit version 1.01 or later and Sysmac Studio version 1.02 or higher are required to use this instruction.

Sample Programming

The following programming example determines if the ON time of the sensor output is equal to or greater than the threshold value. The operation mode can be either the threshold setting mode or the execution mode. The operations of these modes are described in the following table.

Operation mode	Operation
Threshold setting mode	The ON time of the sensor output is measured and the resulting value is set as the threshold.
Execution mode	The ON time of the sensor output is measured and compared with the threshold. If the ON time is equal to or greater than the threshold, the operation is considered normal.

The time is compared in milliseconds. The TruncTime instruction is used to truncate the digits in the measured time below milliseconds.

The current operation mode is stored in the *RecentMode* variable. The result is stored in the *Result* variable. The value of *Result* is TRUE if operation is normal and FALSE if there is an error.

Definitions of Global Variables

Data type: Enumeration

Variable	Enumerator	Comment
Mode		Operation mode
SET	0	Threshold setting
EXEC	1	Execution

Global Variables

Variable	Data type	Initial value	Comment
RecentMode	Mode	SET	The current operation mode

LD

Internal Variables	Variable	Data type	Initial value	Comment
	SensorOut	BOOL	FALSE	Sensor output
	ElapsedTime	TIME	T#0s	Elapsed time
	SensorTime	TIME	T#0s	Sensor ON time
	LongTime	TIME	T#1h	A time that is sufficiently longer than the sensor ON time
	ThresholdTime	TIME	T#0s	Threshold
	Result	BOOL	FALSE	Result, TRUE: Normal, FALSE: Error
	TON_instance	TON		

External Variables	Variable	Data type	Comment
	RecentMode	Mode	The current operation mode

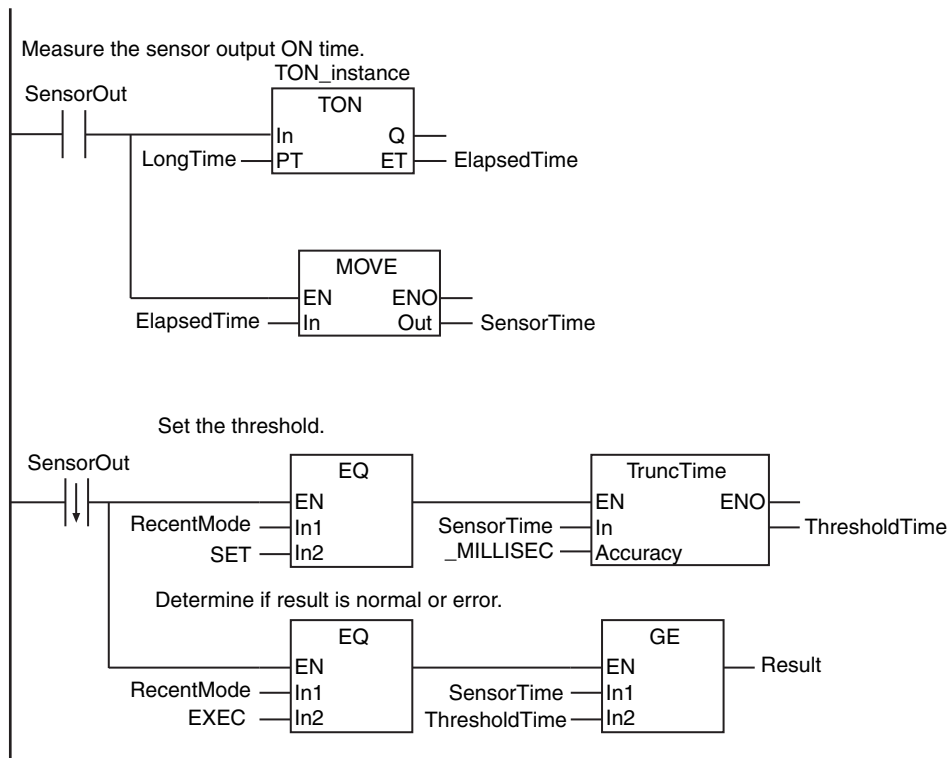

ST

Internal Variables	Variable	Data type	Initial value	Comment
	SensorOut	BOOL	FALSE	Sensor output
	ElapsedTime	TIME	T#0s	Elapsed time
	SensorTime	TIME	T#0s	Sensor ON time
	LongTime	TIME	T#1h	A time that is sufficiently longer than the sensor ON time
	SensorDone	BOOL	FALSE	Sensor output OFF flag
	ThresholdTime	TIME	T#0s	Threshold
	Result	BOOL	FALSE	Result, TRUE: Normal, FALSE: Error
	TON_instance	TON		
	F_TRIG_instance	F_TRIG		

External Variables	Variable	Data type	Comment
	RecentMode	Mode	The current operation mode

```
// Execute TON instruction.
TON_instance(
  In:=SensorOut,    // Timer input
  PT:=LongTime,    // Set time
  ET=>ElapsedTime); // Elapsed time

// Set sensor ON time to the elapsed time of TON.
IF (SensorOut=TRUE) THEN
  SensorTime:=ElapsedTime;
END_IF;

// Detect when sensor output turns OFF.
F_TRIG_instance(Clk:=SensorOut, Q=>SensorDone);
Result:=FALSE;

// Set the threshold.
IF (SensorDone=TRUE AND RecentMode=SET) THEN
  ThresholdTime:=TruncTime(
    In      :=SensorTime,
    Accuracy:=_MILLISEC); // Accuracy is milliseconds.
// Determine if result is normal or error.
ELSIF (SensorDone=TRUE AND RecentMode=EXEC) THEN
  IF (SensorTime >= ThresholdTime) THEN
    Result:=TRUE;
  END_IF;
END_IF;
```

TruncDt

The TruncDt instruction truncates a DT variable below the specified time unit.

Instruction	Name	FB/FUN	Graphic expression	ST expression
TruncDt	Truncate Date and Time	FUN		Out:=TruncDt(In, Accuracy);

Variables

Name	Meaning	I/O	Description	Valid range	Unit	Default
In	Date and time to truncate	Input	Date and time to truncate	Depends on data type.	Year, month, day, hour, minutes, seconds	DT#1970-1-1-0:0:0
Accuracy	Smallest unit after truncation		The smallest time unit to leave after truncation	_NANOSEC, _MICROSEC, _MILLISEC, _SEC	---	_NANOSEC
Out	Date and time after truncation	Output	Date and time after truncation	Depends on data type.	Year, month, day, hour, minutes, seconds	---

	Boolean	Bit strings					Integers							Real numbers	Times, durations, dates, and text strings					
	BOOL	BYTE	WORD	DWORD	LWORD	USINT	UINT	UDINT	ULINT	SINT	INT	DINT	LINT	REAL	LREAL	TIME	DATE	TOD	DT	STRING
In																			OK	
Accuracy	Refer to <i>Function</i> for the enumerators of enumeration type _eSUBSEC.																			
Out																			OK	

Function

The TruncDt instruction truncates all digits below the smallest unit after truncation that is specified in *Accuracy* from the date and time to truncate in *In*. The resulting date and time after truncation is stored in date and time after truncation *Out*.

The data type of *Accuracy* is enumerated type _eSUBSEC. The meanings of the enumerators are as follows:

Enumerator	Meaning
_NANOSEC	Nanoseconds
_MICROSEC	Microseconds
_MILLISEC	Milliseconds
_SEC	Seconds

The following example is for when *In* is DT#1970-1-1-12:34:56.789012345 and *Accuracy* is *_SEC*.

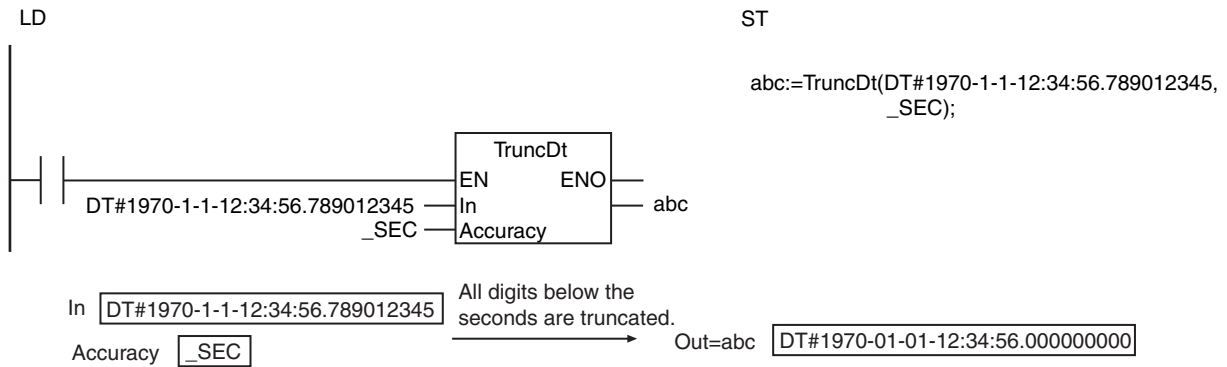

Additional Information

Before you compare two DT variables with the EQ (=) instruction (page 2-92) or other instructions, use the TruncDt instruction to convert the two variables to the same accuracy.

Precautions for Correct Use



Version Information

A CPU Unit with unit version 1.01 or later and Sysmac Studio version 1.02 or higher are required to use this instruction.

Sample Programming

The following programming example records the date and time and the current voltage when a sensor output turns ON.

The date and time is recorded in milliseconds.

The sensor output is stored in *SensorOut* and the voltage is stored in *Voltage*. The current date and time is obtained with the GetTime instruction.

The date and times and the voltages are stored in order in a *Stack* variable as *Recent* structures whose members are the date and time and corresponding voltage.

Definitions of Global Variables

Data Types

Variable	Data type	Comment
Record	STRUCT	Structure
DandT	DT	Date and time
Voltage	REAL	Voltage

Global Variables

Variable	Data type	Initial value	Comment
Recent	Record	(DandT:=DT#1970-1-1-0:0:0,Voltage:=0.0)	Present value
Stack	ARRAY[0..99] OF Record	[100((DandT:=DT#1970-1-1-0:0:0,Voltage:=0.0))]	Stack

LD

Internal Variables	Variable	Data type	Initial value	Comment
	SensorOut	BOOL	FALSE	Sensor output
	Voltage	REAL	0.0	Voltage
	NumDat	UINT	UINT#0	Current number of stored data

External Variables	Variable	Data type	Comment
	Recent	Record	Present value
	Stack	ARRAY[0..99] OF Record	Stack

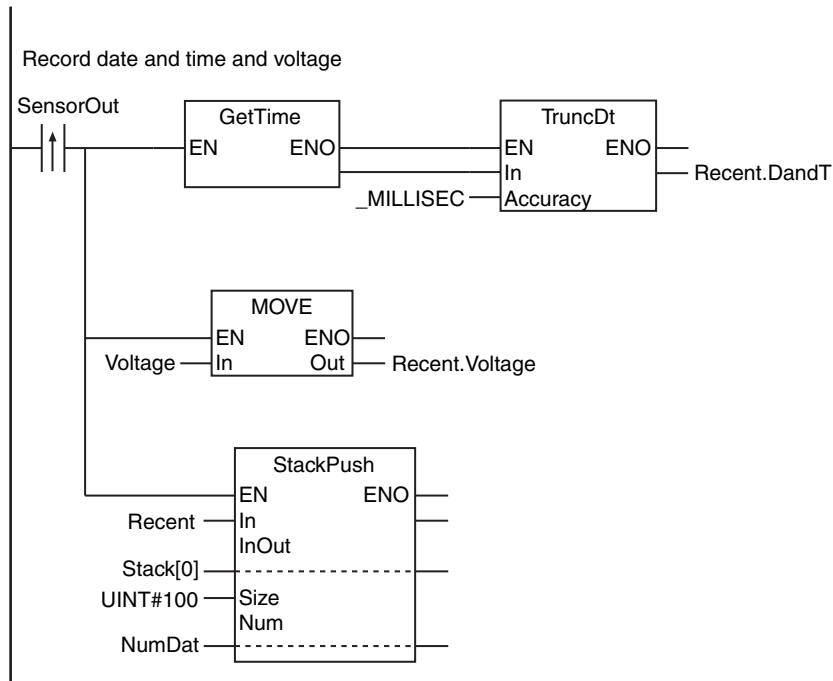

ST

Internal Variables	Variable	Data type	Initial value	Comment
	Trigger	BOOL	FALSE	Trigger
	SensorOut	BOOL	FALSE	Sensor output
	Voltage	REAL	0.0	Voltage
	NumDat	UINT	UINT#0	Current number of stored data
	R_TRIG_instance	R_TRIG		

External Variables	Variable	Data type	Comment
	Recent	Record	Present value
	Stack	ARRAY[0..99] OF Record	Stack

```
// Activate trigger when sensor output turns ON.
R_TRIG_instance(SensorOut, Trigger);

IF (Trigger=TRUE) THEN
  // Store the current date and time down to the milliseconds.
  Recent.DandT:=TruncDt(
    In      :=GetTime(), // Get the date and time.
    Accuracy:=_MILLISEC); // Accuracy is milliseconds.

  // Get current voltage.
  Recent.Voltage:=Voltage;

  // Record date and time and voltage in stack.
  StackPush(
    In      :=Recent, // Date and time, and voltage
    InOut:=Stack[0], // Stack array
    Size :=UINT#100, // Number of stack array elements: 100
    Num   :=NumDat); // Number of data currently stored
END_IF;
```

TruncTod

The TruncTod instruction truncates a TOD variable below the specified time unit.

Instruction	Name	FB/FUN	Graphic expression	ST expression
TruncTod	Truncate Time of Day	FUN		Out:=TruncTod(In, Accuracy);

Variables

Name	Meaning	I/O	Description	Valid range	Unit	Default
In	Time of day to truncate	Input	Time of day to truncate	Depends on data type.	Hour, minutes, seconds	TOD#0:0:0
Accuracy	Smallest unit after truncation		The smallest time unit to leave after truncation	_NANOSEC, _MICROSEC, _MILLISEC, _SEC	---	_NANOSEC
Out	Time of day after truncation	Output	Time of day after truncation	Depends on data type.	Hour, minutes, seconds	---

	Boolean	Bit strings					Integers							Real numbers		Times, durations, dates, and text strings				
	BOOL	BYTE	WORD	DWORD	LWORD	USINT	UINT	UDINT	ULINT	SINT	INT	DINT	LINT	REAL	LREAL	TIME	DATE	TOD	DT	STRING
In																		OK		
Accuracy	Refer to <i>Function</i> for the enumerators of enumeration type <code>_eSUBSEC</code> .																			
Out																		OK		

Function

The TruncTod instruction truncates all digits below the smallest unit after truncation that is specified in *Accuracy* from the time of day to truncate in *In*. The resulting time of day after truncation is stored in time of day after truncation *Out*.

The data type of *Accuracy* is enumerated type `_eSUBSEC`. The meanings of the enumerators are as follows:

Enumerator	Meaning
<code>_NANOSEC</code>	Nanoseconds
<code>_MICROSEC</code>	Microseconds
<code>_MILLISEC</code>	Milliseconds
<code>_SEC</code>	Seconds

The following example is for when *In* is TOD#12:34:56.789012345 and *Accuracy* is `_MILLISEC`.

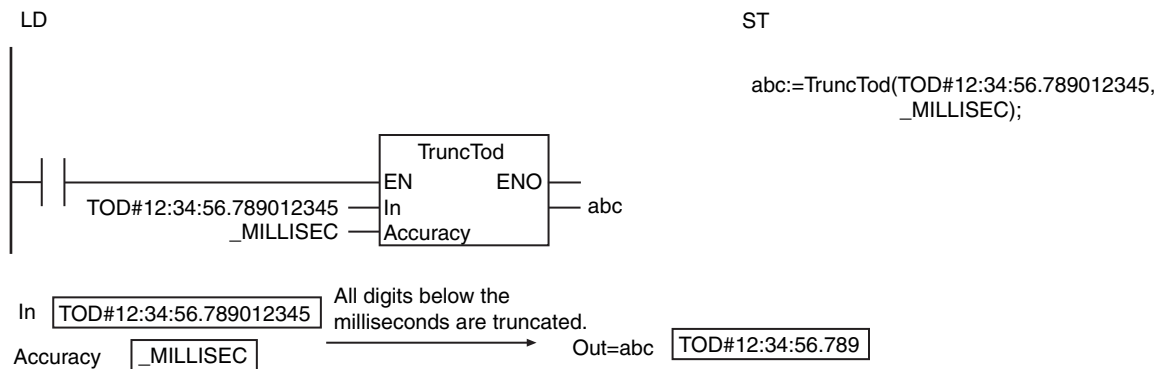

Additional Information

Before you compare two TOD variables with the EQ (=) instruction (page 2-92) or other instructions, use the TruncTod instruction to convert the two variables to the same accuracy.

Precautions for Correct Use



Version Information

A CPU Unit with unit version 1.01 or later and Sysmac Studio version 1.02 or higher are required to use this instruction.

Sample Programming

The following programming example records the time of day and the current voltage when a sensor output turns ON.

The time of day is recorded in seconds.

The sensor output is stored in *SensorOut* and the voltage is stored in *Voltage*. The current time of day is obtained with the GetTime and DT_TO_TOD instructions.

The times of day and the voltages are stored in order in a *Stack* variable as *Recent* structures whose members are the time of day and corresponding voltage.

Definitions of Global Variables

Data Types

Variable	Data type	Comment
Record	STRUCT	Structure
TofD	TOD	Time of day
Voltage	REAL	Voltage

Global Variables

Variable	Data type	Initial value	Comment
Recent	Record	(TofD:=TOD#0:0:0,Voltage:=0.0)	Present value
Stack	ARRAY[0..99] OF Record	[100((TofD:=TOD#0:0:0,Voltage:=0.0))]	Stack

LD

Internal Variables	Variable	Data type	Initial value	Comment
	SensorOut	BOOL	FALSE	Sensor output
	Voltage	REAL	0.0	Voltage
	NumDat	UINT	UINT#0	Current number of stored data

External Variables	Variable	Data type	Comment
	Recent	Record	Present value
	Stack	ARRAY[0..99] OF Record	Stack

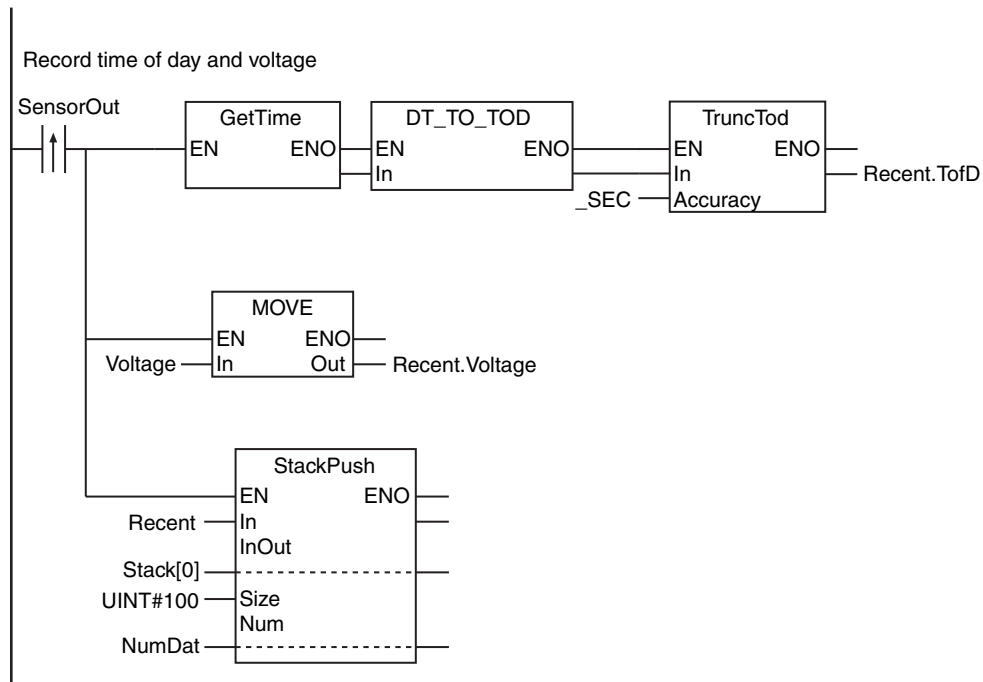

ST

Internal Variables	Variable	Data type	Initial value	Comment
	Trigger	BOOL	FALSE	Trigger
	SensorOut	BOOL	FALSE	Sensor output
	TmpTod	TOD	TOD#0:0:0	Temporary variable
	Voltage	REAL	0.0	Voltage
	NumDat	UINT	UINT#0	Current number of stored data
	R_TRIG_instance	R_TRIG		

External Variables	Variable	Data type	Comment
	Recent	Record	Present value
	Stack	ARRAY[0..99] OF Record	Stack

```
// Activate trigger when sensor output turns ON.
R_TRIG_instance(SensorOut, Trigger);

IF (Trigger=TRUE) THEN
  // Store the current time of day down to the seconds.
  TmpTod      :=DT_TO_TOD(GetTime()); // Get time of day.
  Recent.TofD:=TruncTod(
    In      :=TmpTod,
    Accuracy:=_SEC); // Accuracy is seconds.

  // Get current voltage.
  Recent.Voltage:=Voltage;

  // Record time of day and voltage in stack.
  StackPush(
    In      :=Recent, // Time of day and voltage
    InOut:=Stack[0], // Stack array
    Size :=UINT#100, // Number of stack array elements: 100
    Num  :=NumDat); // Number of data currently stored
END_IF;
```

Analog Control Instructions

Instruction	Name	Page
PIDAT	PID Control with Autotuning	2-666
PIDAT_HeatCool	Heating/Cooling PID with Autotuning	2-691
TimeProportionalOut	Time-proportional Output	2-729
LimitAlarm_**	Upper/Lower Limit Alarm Group	2-745
LimitAlarmDv_**	Upper/Lower Deviation Alarm Group	2-749
LimitAlarmDvStbySeq_**	Upper/Lower Deviation Alarm with Standby Sequence Group	2-754
ScaleTrans	Scale Transformation	2-769
AC_StepProgram	Step Program	2-772

PIDAT

The PIDAT instruction performs PID control with autotuning (2-PID control with set point filter).

Instruction	Name	FB/FUN	Graphic expression	ST expression
PIDAT	PID Control with Autotuning	FB		PIDAT_instance(Run, ManCtl, StartAT, PV, SP, OprSetParams, InitSetParams, ProportionalBand, IntegrationTime, DerivativeTime, ManMV, ATDone, ATBusy, Error, ErrorID, MV);

Variables

Name	Meaning	I/O	Description	Valid range	Unit	Default
Run	Execution condition	Input	TRUE: Execute FALSE: Stop	Depends on data type.	---	FALSE
ManCtl	Manual/auto control		TRUE: Manual operation FALSE: Automatic operation			
StartAT	Autotuning execution condition		TRUE: Execute FALSE: Cancel			
PV	Process value		Process value			
SP	Set point		Set point			
OprSet Params	Operation setting parameters		Parameters set during operation			
InitSet Params	Initial setting parameters		Initial setting parameters			
Proportional Band	Proportional band	In-out	Proportional band	0.01 to 1000.00	% FS	---
Integration-Time	Integration time		Integration time The higher the value is, the weaker the integral action is. No integral action is performed for 0.	T#0.0000s to T#10000.0000s*2	s	
DerivativeTime	Derivative time		Derivative time The higher the value is, the stronger the derivative action is. No derivative action is performed for 0.	T#0.0000s to T#10000.0000s*2		
ManMV	Manual manipulated variable		Manual manipulated variable	-320 to 320	%	

Name	Meaning	I/O	Description	Valid range	Unit	Default
ATDone	Autotuning normal completion	Output	TRUE: Normal completion FALSE: *3	Depends on data type.	---	---
ATBusy	Autotuning busy		TRUE: Autotuning FALSE: Not autotuning			
MV	Manipulated variable		Manipulated variable	-320 to 320	%	

*1 Value of input range lower limit *InitSetParams.RngLowLmt* to Value of input range upper limit *InitSetParams.RngUpLmt*

*2 Digits below 0.0001 s are truncated.

*3 FALSE indicates an error end, that PID control is in progress without autotuning, or that PID control is not in progress.

	Boolean	Bit strings				Integers								Real numbers		Times, durations, dates, and text strings					
	BOOL	BYTE	WORD	DWORD	LWORD	USINT	UINT	UDINT	ULINT	SINT	INT	DINT	LINT	REAL	LREAL	TIME	DATE	TOD	DT	STRING	
Run	OK																				
ManCtl	OK																				
StartAT	OK																				
PV														OK							
SP														OK							
OprSet Params	Refer to <i>Function</i> for details on the structure <i>_sOPR_SET_PARAMS</i> .																				
InitSet Params	Refer to <i>Function</i> for details on the structure <i>_sINIT_SET_PARAMS</i> .																				
Proportiona I Band														OK							
Integration Time																OK					
Derivative Time																OK					
ManMV														OK							
ATDone	OK																				
ATBusy	OK																				
MV														OK							

Function

The PIDAT instruction performs PID control of a manipulated variable for a temperature controller or other device. PID control is started when the value of execution condition *Run* changes to TRUE. While the value of *Run* is TRUE, the following process is repeated periodically: process value *PV* is read, PID processing is performed, and manipulated variable *MV* is output. PID control is stopped when the value of *Run* changes to FALSE.

Autotuning is supported to automatically find the optimum PID constants. When the value of the autotuning execution condition *StartAT* changes to TRUE, the PID constants are autotuned.

Structure Specifications

The data type of operation setting parameter *OprSetParams* is structure `_sOPR_SET_PARAMS`. The specifications are as follows:

Name	Meaning	Description	Data type	Valid range	Unit	Default
OprSetParams	Operation Setting Parameters	Parameters that are set during operation.	<code>_sOPR_SET_PARAMS</code>	---	---	---
MVLowLmt	MV Lower Limit	The lower limit of the MV.	REAL	-320 to 320*	%	0
MVUpLmt	MV Upper Limit	The upper limit of the MV.	REAL			100
ManResetVal	Manual Reset Value	The value of MV when the deviation is 0 for the proportional action.	REAL			-320 to 320
MVTrackSw	MV Tracking Switch	TRUE: ON FALSE: OFF	BOOL	Depends on data type.	---	FALSE
MVTrackVal	MV Tracking Value	The value that is set in MV during MV tracking.	REAL	-320 to 320	%	0
StopMV	Stop MV	The value that is set in MV when instruction execution is stopped.	REAL			
ErrorMV	Error MV	The value that is set in MV when an error occurs.	REAL			
Alpha	2-PID Parameter α	The set point filter is disabled if the set point filter coefficient α is 0.	REAL	0.00 to 1.00	---	0.65
ATCalcGain	Autotuning Calculation Gain	Adjustment coefficient from autotuning results. Stability is given higher priority with higher values. The speed of response is given higher priority with lower values.	REAL	0.1 to 10.0		1.0
ATHystrs	Autotuning Hysteresis	The hysteresis of the limit cycle.	REAL			% FS

* *MVLowLmt* must be less than *MVUpLmt*.

The data type of initial setting parameter *InitSetParams* is structure `_sINIT_SET_PARAMS`. The specifications are as follows:

Name	Meaning	Description	Data type	Valid range	Unit	Default
InitSetParams	Initial Setting Parameters	Initial setting parameters.	<code>_sINIT_SET_PARAMS</code>	---	---	---
SampTime	Sampling Period	The period for PID processing.	TIME	T#0.0001s to #100.0000s	s	T#0.1s
RngLowLmt	Lower Limit of Input Range	The lower limit of PV and SP.	REAL	-32000 to 32000*	---	0
RngUpLmt	Upper Limit of Input Range	The upper limit of PV and SP.	REAL			100
DirOpr	Action Direction	TRUE: Forward action FALSE: Reverse action	BOOL	Depends on data type.	---	FALSE

* *RngLowLmt* must be less than *RngUpLmt*.

Meanings of Variables

The meanings of the variables that are used in this command are described below.

- **Run (Execution Condition)**

This is the execution condition for the instruction. PID control is performed while the value is TRUE. PID control is stopped when the value changes to FALSE.

- **ManCtl (Manual/Auto Control)**

This instruction can be executed in one of two modes: Manual operation or automatic operation. The value of *ManCtl* determines which mode is used.

Value of <i>ManCtl</i>	Operation mode	Value of <i>MV</i>
TRUE	Manual	Value of <i>ManMV</i> (PID control is not performed.)
FALSE	Automatic	Value that is calculated for PID control

- **StartAT (Autotuning Execution Condition)**

This is the execution condition for autotuning the PID constants. If the value of *StartAT* is TRUE when the value of *Run* changes to TRUE, autotuning is performed when PID control is started. If the value of *StartAT* changes to TRUE during PID control (i.e., when the value of *Run* is TRUE), autotuning is performed during PID control. In either case, autotuning is canceled if the value of *StartAT* changes to FALSE during autotuning. Autotuning is described in more detail later.

- **PV (Process Value)**

This is the process value of the controlled system.

- **SP (Set Point)**

This is the set point for the controlled system.

- **MVLowLmt (MV Lower Limit) and MVUpLmt (MV Upper Limit)**

You can limit the value of *MV*. *MVLowLmt* and *MVUpLmt* are the lower and upper limits to *MV*. *MVLowLmt* must always be less than *MVUpLmt*.

<i>MV</i> from PID processing	Value of <i>MV</i>
Less than <i>MVLowLmt</i>	<i>MVLowLmt</i>
Between <i>MVLowLmt</i> and <i>MVUpLmt</i> , inclusive	<i>MV</i> from PID processing
Greater than <i>MVUpLmt</i>	<i>MVUpLmt</i>

If stop *MV StopMV*, error *MV ErrorMV*, or manual *MV ManMV* is set in manipulated variable *MV*, limit control is not applied.

You can change *MVLowLmt* or *MVUpLmt* even if the control status of this instruction is not autotuning during automatic operation.

However, if you change *MVLowLmt* or *MVUpLmt* to an expansion direction during operation, the value of *MV* which is the same as one in the last sampling period is output and changed smoothly at this time (bumpless).

Repeated changing of *MVLowLmt* or *MVUpLmt* will effect the control performance so that sufficient control performance may not obtain.

Confirm the effects on the control performance before you repeatedly change *MVLowLmt* or *MVUpLmt* during operation.

- ***ManResetVal* (Manual Reset Value)**

This is the value of *MV* when the deviation (i.e., the difference between *PV* and *SP*) is 0 for the proportional action. The value of *ManResetVal* determines the location of the proportional action band. When integral operation is performed, the manual reset value is ignored. Therefore, the setting of *ManResetVal* is enabled when the value of *IntegrationTime* is 0.

- ***MVTrackSw* (MV Tracking Switch)**

MV tracking is a function that sets the *MV* to an external input value (called the MV tracking value) during automatic operation. MV tracking is performed while the value of *MVTrackSw* is TRUE. When the value of *MVTrackSw* changes to FALSE, the value of *MV* returns to the result of PID processing. The value of *MV* is changed smoothly at this time (bumpless).

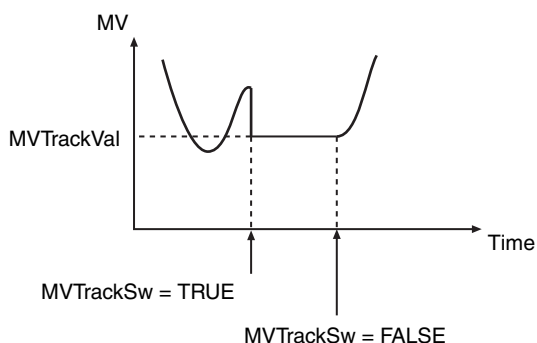

- ***MVTrackVal* (MV Tracking Value)**

This is the value to which *MV* is set during MV tracking. The value of *MVTrackVal* is limited by the values of *MVLowLmt* and *MVUpLmt*.

- ***StopMV* (Stop MV)**

This is the value to which *MV* is set when the value of *Run* is FALSE (i.e., when execution of this instruction is stopped).

- ***ErrorMV* (Error MV)**

This is the value to which *MV* is set when an error occurs (i.e., when the value of *Error* is TRUE). If the value of *ErrorMV* is not within the valid range (–320 to 320), the value of *MV* will be 0 when an error occurs.

- ***Alpha* (2-PID Parameter α)**

This parameter determines the coefficient of the set point filter. Refer to the description in *2-PID Control with Set Point Filter* on page 2-676 for details. Normally set the value of *Alpha* to 0.65.

- ***ATCalcGain* (Autotuning Calculation Gain)**

This variable gives the coefficient of the PID constants that were calculated by autotuning when they are applied to the actual PID constants. If a value of 1.00 is specified, the results of autotuning are used directly. Increase the value of *ATCalcGain* to give priority to stability and decrease it to give priority to response.

- ***ATHystrs* (Autotuning Hysteresis)**

This is the hysteresis that is used in the limit cycle for autotuning. More accurate tuning is achieved if the value of *ATHystrs* is small. However, if the process value is not stable and proper autotuning is difficult, increase the value. Refer to the description of autotuning for details.

● **SampTime (Sampling Period)**

This is the minimum value of the period for PID processing. Refer to the description of the execution timing of PID processing for details. PID processing is not performed again until the time specified for *SampTime* has elapsed since the last time PID processing was performed.

● **RngLowLmt (Lower Limit of Input Range) and RngUpLmt (Upper Limit of Input Range)**

These are the lower limit and upper limit of *PV* and *SP*. An error will occur if the value of the parameter connected to *PV* or *SP* exceeds either of these limits. *RngLowLmt* must always be less than *RngUpLmt*.

● **DirOpr (Action Direction)**

This variable specifies if *MV* is increased or decreased for changes in the value of *PV*. These are called a forward action and a reverse action.

Value of <i>DirOpr</i>	Meaning	Value of <i>MV</i>
TRUE	Forward action	Increases with the value of <i>PV</i> .
FALSE	Reverse action	Decreases with the value of <i>PV</i> .

The difference between a forward action and reverse action are described here for temperature control. A forward action is used to control the *MV* for a cooling device. That is, the higher the process temperature, the larger the *MV* of the cooling device must be. On the other hand, a reverse action is used to control the *MV* for a heating device. That is, the lower the process temperature, the larger the *MV* of the heating device must be.

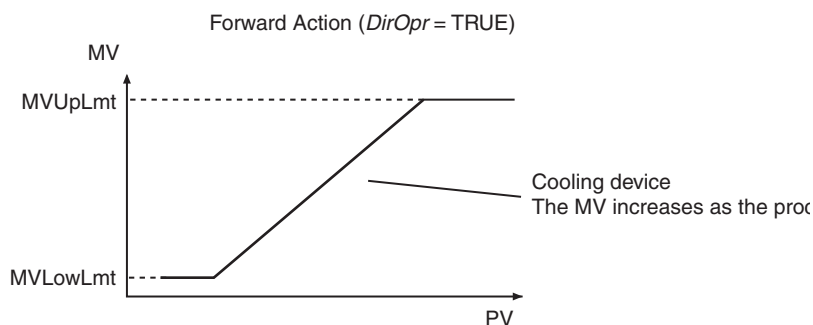

● **ProportionalBand (Proportional Band)**

This is one of the three PID constants. Refer to the description of the proportional action for details. The larger the *ProportionalBand* is, the greater the offset is. Hunting occurs if the *ProportionalBand* is too small.

● **IntegrationTime (Integration Time)**

This is one of the three PID constants. Refer to the description of the integral action for details. The larger the value of *IntegrationTime* is, the weaker the integral action is.

- **DerivativeTime (Derivative Time)**

This is one of the three PID constants. Refer to the description of the derivative action for details. The larger the value of *DerivativeTime* is, the stronger the derivative action is.

- **ManMV (Manual Manipulated Variable)**

MV is set to this value during manual operation (while *ManCtl* is TRUE). However, immediately after changing from automatic to manual operation, the value of *MV* from automatic operation is used. *MV* is set to the value of *ManMV* only when it changes after operation switches to manual operation. When operation changes from manual to automatic operation, the value of *MV* from manual operation is used. The value of *ManMV* does not have to be between *MVLowLmt* and *MVUpLmt*.

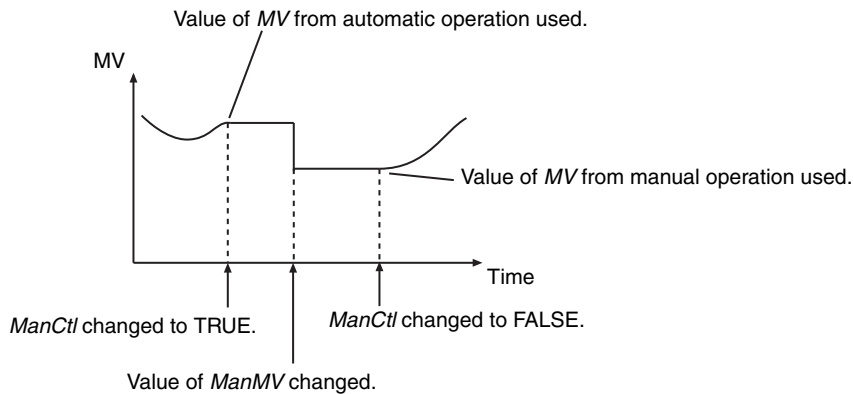

- **ATDone (Autotuning Normal Completion)**

This flag indicates when autotuning was completed normally. It changes to TRUE when autotuning is completed normally and remains TRUE as long as the value of *StartAT* is TRUE. It is FALSE in the following cases.

- An autotuning error end occurred.
- Autotuning is in progress (i.e., while the value of *ATBusy* is TRUE).
- PID control is in progress without autotuning.
- PID control is not in progress (i.e., the value of *Run* is FALSE).
- The value of *StartAT* is FALSE.

- **ATBusy (Autotuning Busy)**

This flag indicates when autotuning is in progress. It is TRUE while autotuning is in progress. Otherwise it is FALSE.

- **MV (Manipulated Variable)**

This is the manipulated variable that is applied to the controlled system.

Introduction to PID Control

PID control is a feedback control method that repeatedly measures the process value of the controlled system and calculates a manipulated variable so that the process value approaches a set point. This instruction therefore outputs a manipulated variable for the following inputs: process value, set point, and calculation parameters. PID control periodically measures the process value, calculates the manipulated variable, and outputs the manipulated variable so that the process value approaches the set point.

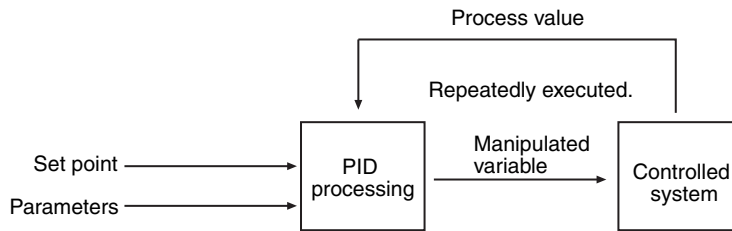

Proportional (P), Integral (I), and Derivative (D) Actions

PID control is performed by combining the proportional action, integral action, and derivative action. These actions are described next.

● Proportional Action (P)

The proportional action increases the absolute value of the manipulated variable in proportion to the deviation between the process value and the set point. The process value of the controlled system changes as shown below.

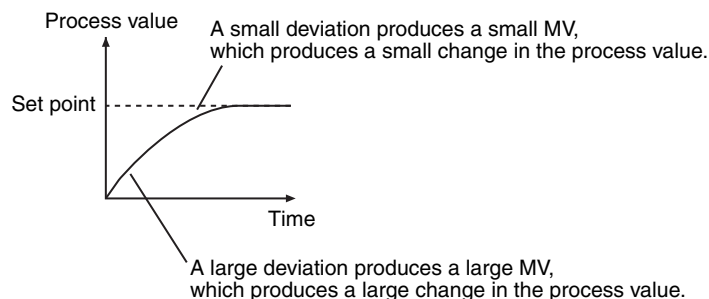

The proportional band is one of the settings that are used for the proportional action. The proportional band is the range of the process value to which the proportional action is applied. If the process value is not in the proportional band, the manipulated variable is set to 100% or 0%. The proportional band is expressed as the percentage of the input range in which to perform the proportional action (% FS). The following diagram shows the proportional band set to 10% FS.

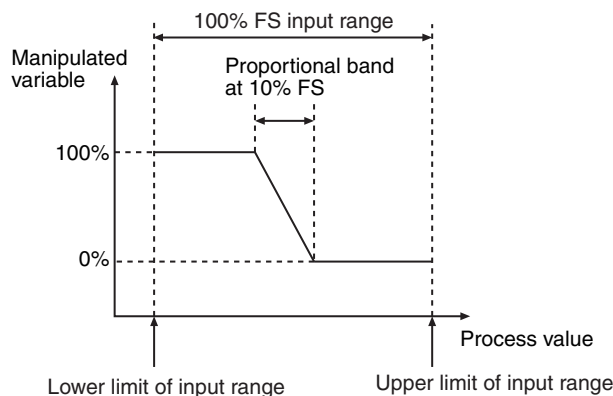

Another parameter for the proportional action is the manual reset value. The manual reset value is the manipulated variable that is used when the deviation is 0. The manual reset value determines the position of the proportional action range in the process value–manipulated variable graph. The relationship between the manual reset value and the proportional action region is shown below.

The position of the proportional action range is determined so that the manipulated variable when the process value and the set point are the same equals the manual reset value.

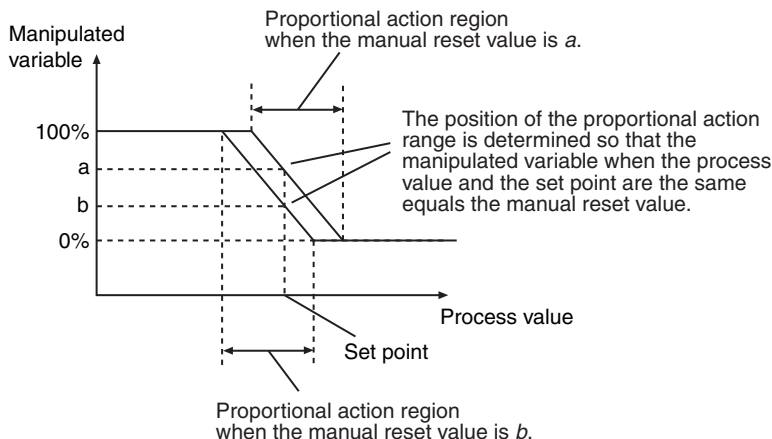

If the manual reset value is not suitable, the deviation will never reach 0. The remaining deviation is called the offset or the residual deviation. You can make the proportional band narrower to reduce the offset. If the proportional band is too narrow, the process value will not stop at the set point. This is called overshooting. If the process value does not stabilize and oscillates around the set point, it is called hunting.

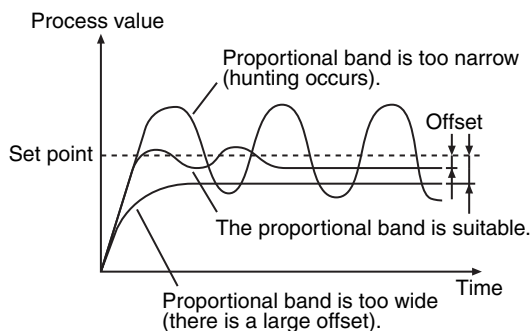

● **Integral Action (I)**

Very accurate adjustment of the proportional band and manual reset value is required to bring the offset to 0 with only the proportional action. Also, the size of the offset varies with the disturbance, so it is necessary to repeat the adjustment frequently. To simplify the operation, an integral action is used in combination with the proportional action. The integral action integrates the deviation on the time axis and then increases the absolute value of the manipulated variable in proportion to the result. When normal distribution operation is performed, the manual reset value is ignored. The following graph on the left shows changes in the manipulated variable for the integral action when a deviation occurs in stepwise fashion. The following graph on the right shows changes in the manipulated variable when the integral and proportional actions are combined.

Manipulated Variable for Integral Action

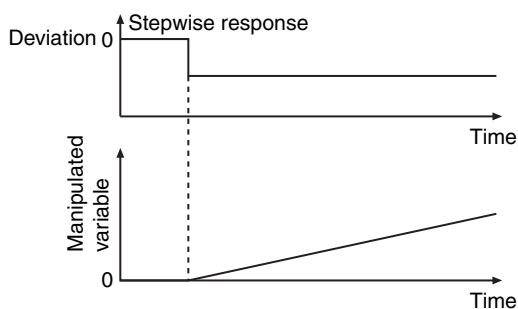

Manipulated Variable for Integral and Proportional Actions Together

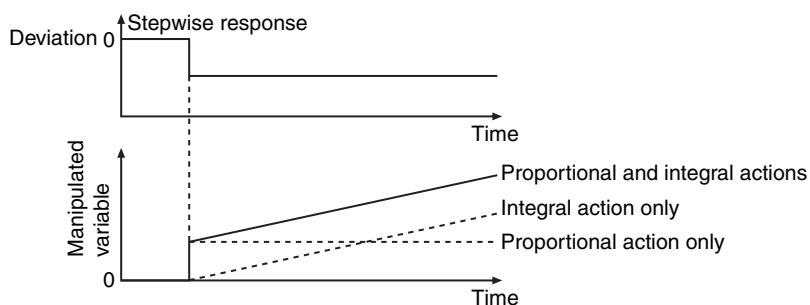

One of the parameters for the integral action is the integration time. This is the time for the manipulated variable from the integral action to equal the manipulated variable from the proportional action when a stepwise deviation occurs. The shorter the integration time is, the stronger the integral action is. A short integration time reduces the time for the offset to reach 0, but it can also cause hunting.

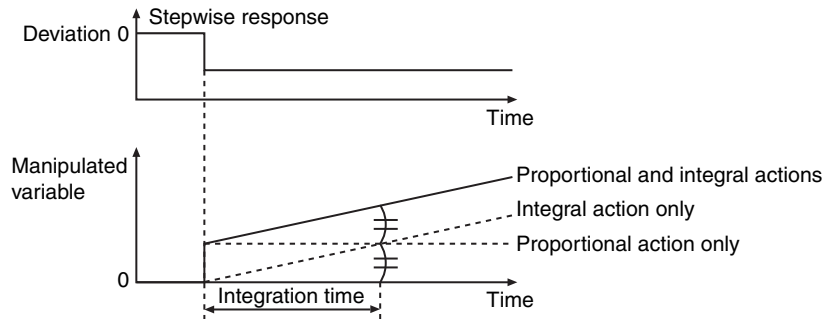

● **Derivative Action (D)**

If the proportional and integral actions are used together, the offset will reach 0 and the process value will reach the set point. However, if disturbance causes the process value to change quickly, time is required to restore the original state. The derivative action functions to quickly return the process value to the set point when there is a disturbance. The derivative action differentiates the deviation on the time axis and then increases the absolute value of the manipulated variable in proportion to the result. In other words, the larger the change in the process value is, the larger the absolute value of the manipulated variable for the derivative action is. The changes in the manipulated variable for the derivative action when a deviation occurs in stepwise fashion are shown below. The changes in the manipulated variable when the derivative and proportional actions are combined are also shown.

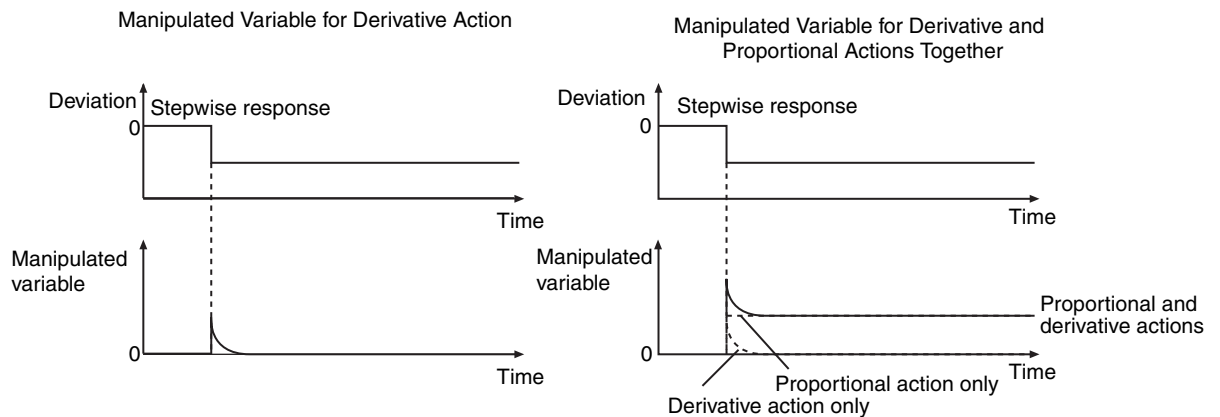

One of the parameters for the derivative action is the derivative time. This is the time for the manipulated variable from the derivative action to equal the manipulated variable from the proportional action when a ramp deviation occurs. The longer the derivative time is, the stronger the derivative action is. A long derivative time provides a rapid response to disturbances, but it can also cause hunting.

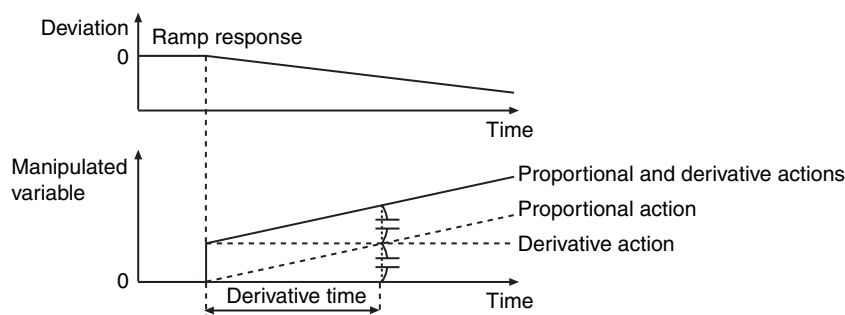

The total of the manipulated variables for the proportional, integral, and derivative actions is the manipulated variable for PID control. The changes in the manipulated variable for PID control for a stepwise and ramp deviations are shown below.

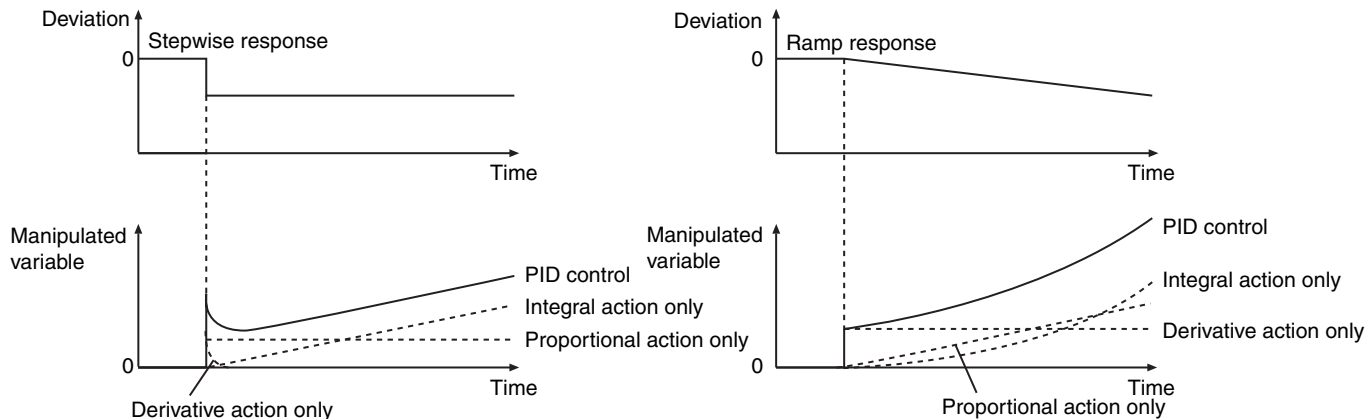

2-PID Control with Set Point Filter

There are three main parameters that you must adjust to perform PID control: the proportional band, integration time, and derivative time. These are called the PID constants. The values of the PID constants affect the following two performances of PID control.

- Set point response: The ability to follow changes in the set point.
- Disturbance response: The ability of correcting the process value for large changes that are caused by disturbances

A block diagram for basic PID control is shown below. The set point and disturbance enter the block diagram at different positions. Therefore, finding the optimum PID constants for both set point response performance and disturbance response performance is difficult. In other words, if the PID constants are set for set point response, response to disturbances is slow. If the PID constants are set for disturbance response, overshooting occurs.

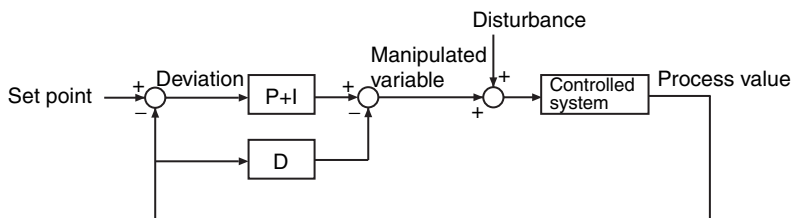

To enable both set point response and disturbance response, 2-PID control is used. The 2 in “2-PID” indicates that there are separate parameters to adjust the set point response and the disturbance response. A block diagram for this is shown below. A set point filter that includes an adjustment parameter is added. The PID constants are adjusted to maximize disturbance response. A set point filter adjusts the set point to optimize the set value response for those values. You can adjust the values of the PID constants and the set value of the set point filter independently to increase both the set point response and the disturbance response.

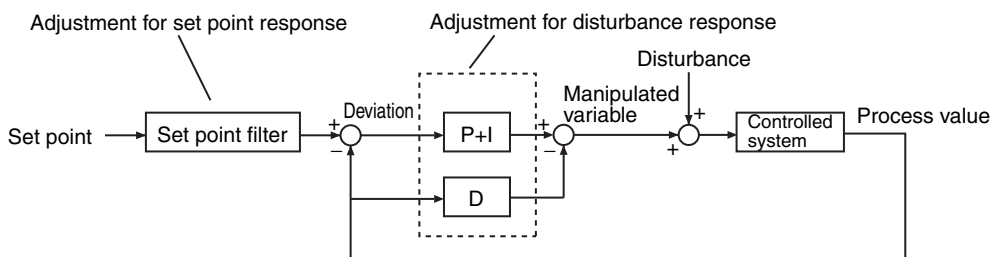

The formulas of the blocks of this instruction are shown below. The set point filter value (i.e., a coefficient for the set point) is adjusted by using the integration time and the 2-PID parameter α . The optimum value of α is 0.65. It normally does not need to be changed. The lower the value of α is, the smaller the influence of the set point filter is.

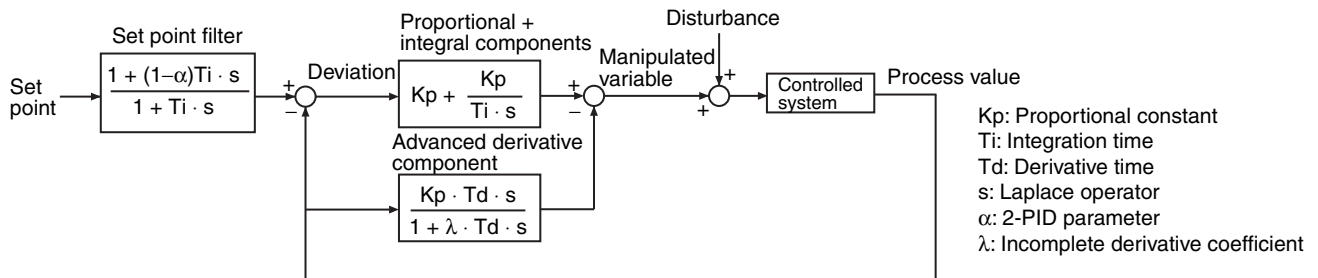

Starting PID Control

You must use suitable PID constants to execute this instruction. There are the following two ways to achieve this.

● When Suitable PID Constants Are Not Known

Perform autotuning at the start of operation to find suitable PID constants. Change the value of *Run* to TRUE while the value of *StartAT* is TRUE. First, autotuning is executed, and then PID control is started with the PID constants that are found.

● When Suitable PID Constants Are Known

Set suitable PID constants in *ProportionalBand*, *IntegrationTime*, and *DerivativeTime*, and then change *Run* to TRUE. *ProportionalBand*, *IntegrationTime*, and *DerivativeTime* are in-out variables. You cannot set constants for the input parameters. Always define suitable variables, and then assign the values to input parameters.

You can change the PID constants during operation. You can also perform autotuning during operation. To start autotuning during operation, change the value of *StartAT* to TRUE.

Control Status and Manipulated Variable

Manipulated variable *MV* is determined according to the control status as shown in the following table.

Control status	Value of variable					Manipulated variable <i>MV</i>	
	<i>ManCtl</i> (manual/auto control)	<i>Run</i> (execution condition)	<i>Error</i> (error end)	<i>MVTrackSw</i> (MV tracking switch)	<i>ATBusy</i> (autotuning busy)		
Error end	FALSE	TRUE	TRUE	---	FALSE	<i>ErrorMV</i> (error MV)	
MV tracking during automatic operation			---	TRUE		TRUE	<i>MVTrackVal</i> (MV tracking value)
Autotuning during automatic operation			FALSE	FALSE	FALSE		Value repeatedly changes between upper limit of MV and lower limit of MV.
Not autotuning during automatic operation			FALSE	FALSE	FALSE		Value calculated with current PID constants.
Instruction execution stopped			FALSE	---	---	FALSE	<i>StopMV</i> (Stop MV)
Manual operation	TRUE	---	---	---	<i>ManMV</i> (manual manipulated variable)		

Autotuning

The 2-PID parameter α is not adjusted very often, so the main parameters that are adjusted for this instruction are the PID constants. The PIDAT instruction supports autotuning of the PID constants. The limit cycle method is used for autotuning. With the limit cycle method, the manipulated variable is temporarily changed to the upper and lower limits of the manipulated variable to find the optimum PID constants based on the resulting changes in the process value. If autotuning is executed when the set point is greater than the process value, the manipulated variable is first set to the upper limit. When the deviation reaches 0, the manipulated variable is set to the lower limit. When the deviation becomes greater than the autotuning hysteresis, the manipulated variable is set to the upper limit again. This process is repeated twice to calculate the optimum PID constants.

If autotuning is executed when the set point is less than the process value, the manipulated variable is first set to the lower limit. Then, the optimum values for the PID constants are calculated with the procedure that is given above.

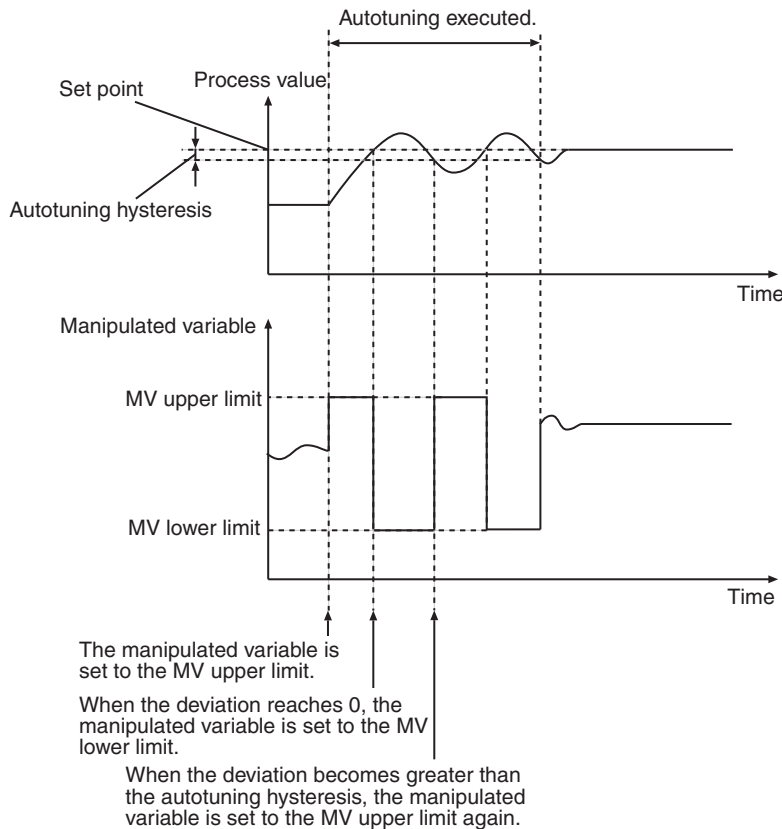

Autotuning is executed during PID control (i.e., when the value of *Run* is TRUE) if the value of *StartAT* changes to TRUE. If *StartAT* is TRUE when *Run* changes to TRUE, autotuning is executed at the start of PID control. When autotuning is completed normally, the calculated PID constants are used immediately. Autotuning is canceled if the value of *StartAT* changes to FALSE during autotuning (i.e., when *ATBusy* is TRUE). If autotuning is canceled, PID control is started again with the previous PID constants.

Execution Timing of PID Control

PID control is repeated periodically. PID processing is performed when the PIDAT instruction is executed in the user program. However, if sampling period *SampTime* has not elapsed since the last time PID processing was performed, PID processing is not performed. If the elapsed time since the last time PID processing was executed exceeds *SampTime*, the excess time (elapsed time – *SampTime*) is carried forward to the next period. This is shown in the following diagram.

Task period = 60 ms and *SampTime* < 60 ms

The task period is greater than or equal to *SampTime*, so PID processing is executed once every task period.

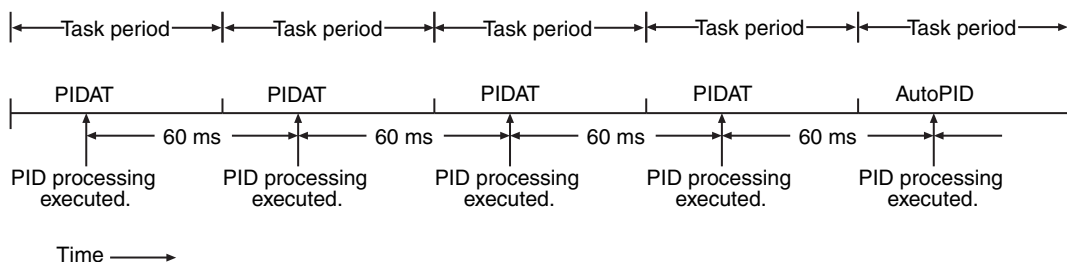

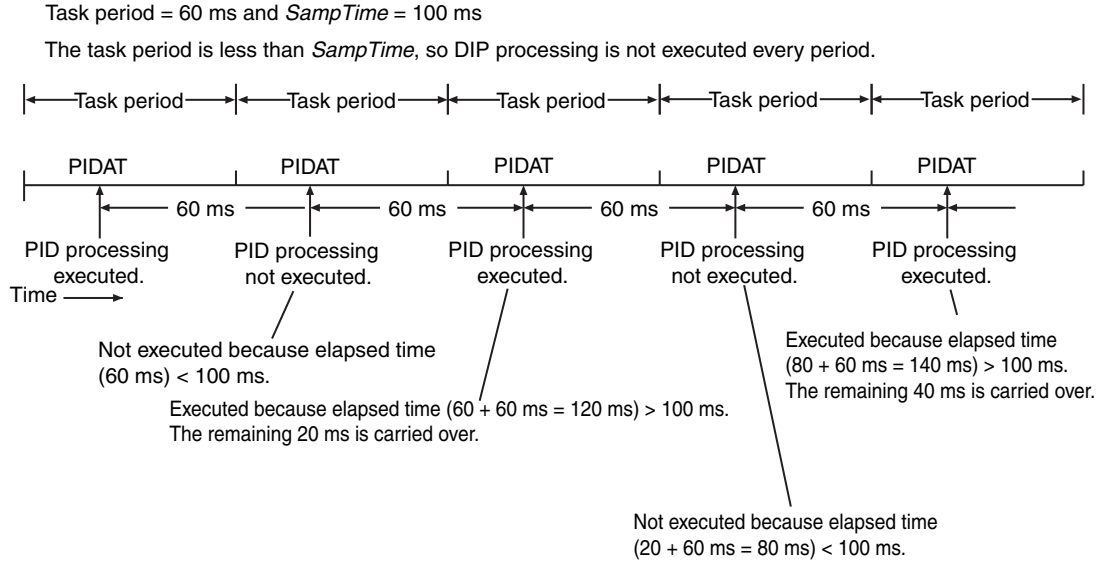

Timing Charts

Timing charts for the instruction variables are provided below for different situations.

● Autotuning Executed during Automatic Operation

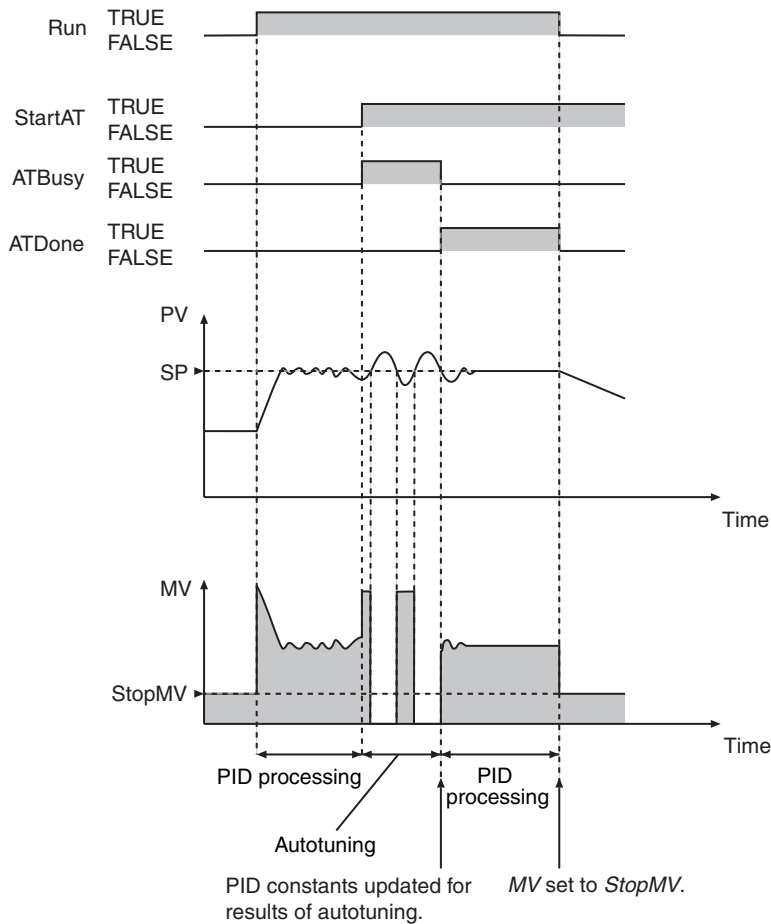

● Autotuning Executed at the Start of PIDAT Execution

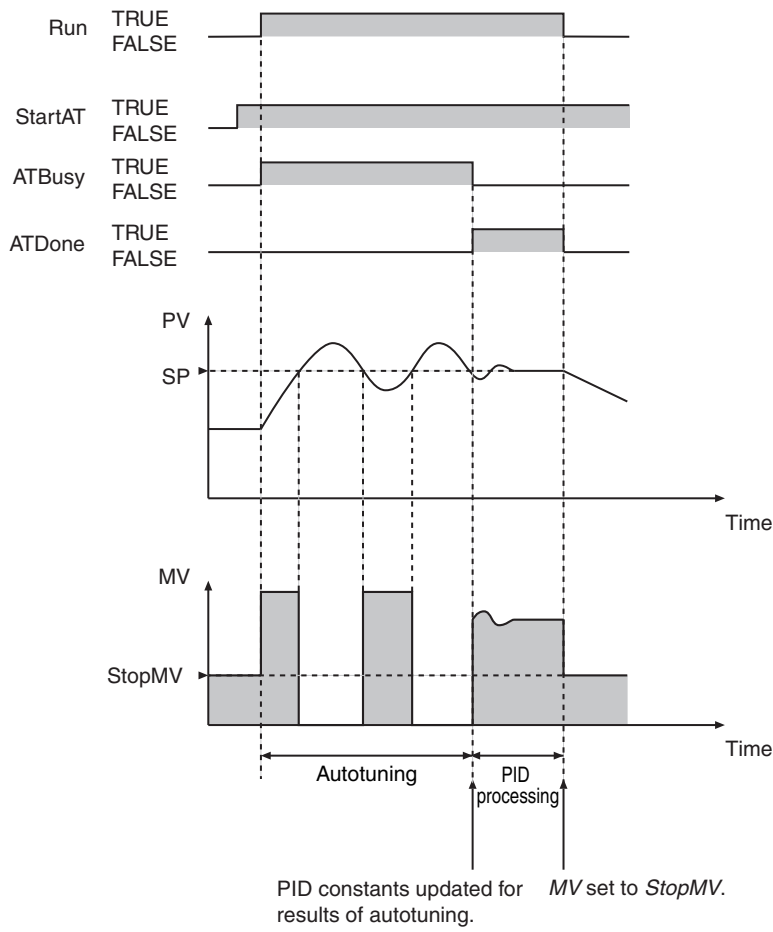

● **Autotuning Canceled**

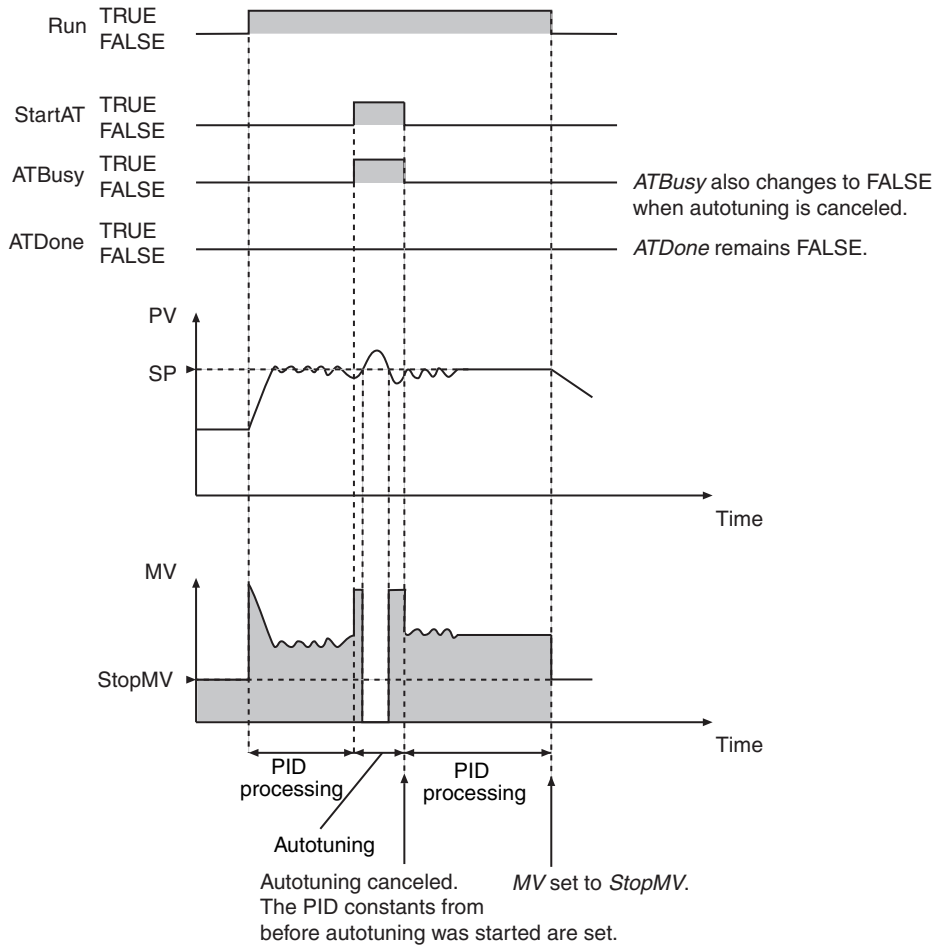

● **An Autotuning Error Occurs during Autotuning**

An autotuning error occurs and autotuning is stopped in the following cases.

- If the MV equals the MV upper limit and the time for the deviation to reach 0 exceeds 19,999 s.
- If the MV equals the MV lower limit and the time for the deviation to reach *ATHystrs* or higher exceeds 19,999 s.

If autotuning is canceled, PID control is started again with the previous PID constants.

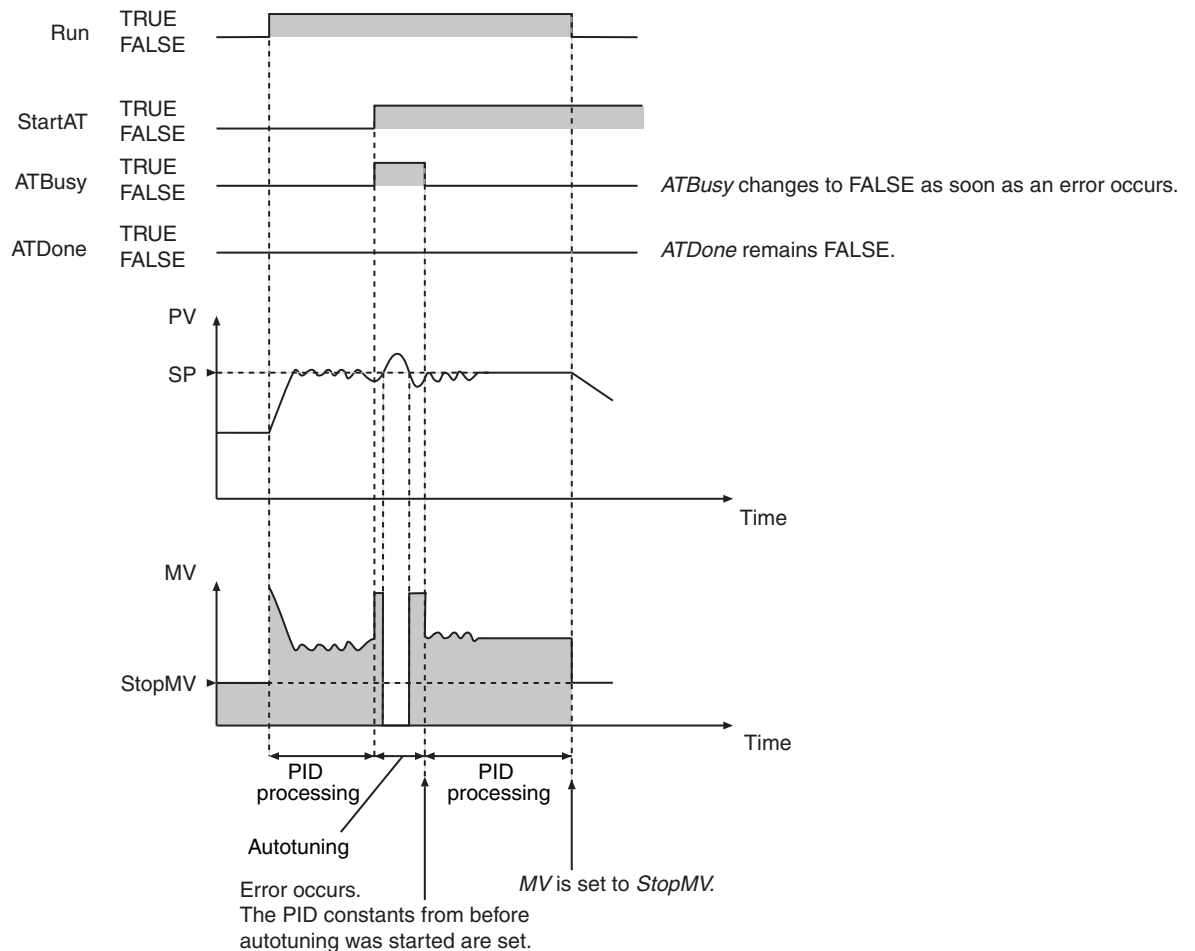

Additional Information

Adjusting PID Constants

- If you need to eliminate hunting even if it takes time to stabilize the control system, increase the value of *ProportionalBand*. If a certain amount of hunting is not a problem, but it is necessary for the controlled system to stabilize quickly, decrease the value of *ProportionalBand*.

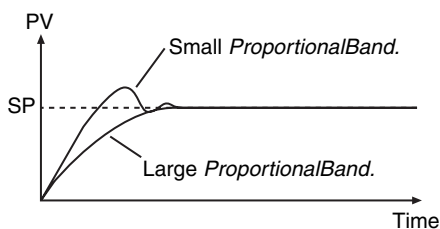

- If hunting continues too long, increase *ProportionalBand* or increase *IntegrationTime*.

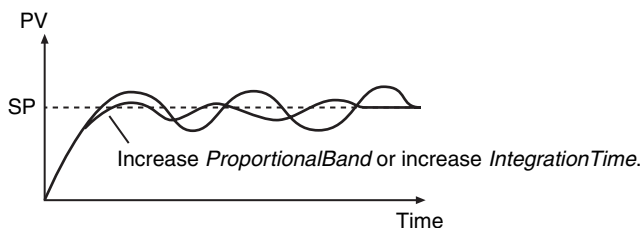

- If rapid hunting occurs, decrease *DerivativeTime*.

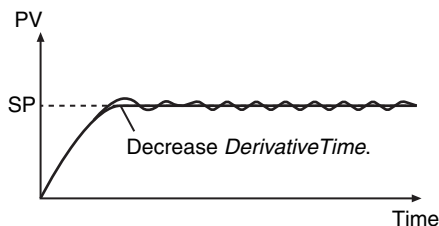

Initial PID Constants for Temperature Control

If you use the PIDAT instruction for temperature control, use the following initial values of the PID constants as reference. Use the default values for the other variables.

Variables	Initial values (reference values)*
ProportionalBand	10%FS
IntegrationTime	233 s
DerivativeTime	40 s

* If you perform autotuning, use the results from autotuning.

Precautions for Correct Use

- The values of PV and SP must be between the values of *RngLowLmt* and *RngUpLmt*, inclusive. Align the units of these variables as shown below.

Unit	Values of PV and SP	Values of <i>RngLowLmt</i> and <i>RngUpLmt</i>
% FS	$PV = (\text{Process value in physical units} - \text{MIN}) / (\text{MAX} - \text{MIN}) \times 100$ $SP = (\text{Set point in physical units} - \text{MIN}) / (\text{MAX} - \text{MIN}) \times 100^*$	<i>RngLowLmt</i> = 0 <i>RngUpLmt</i> = 100
Physical unit	PV = Process value in physical units SV = Set point in physical units	<i>RngLowLmt</i> = MIN <i>RngUpLmt</i> = MAX*

* MAX: Upper limit of input range in physical units, MIN: Lower limit of input range in physical units,

- The following table shows which variables can be changed depending on the operating status.

Variables	Control status		
	Instruction execution stopped*1	Automatic operation when autotuning is not being executed*2	Automatic operation when autotuning is being executed*3
Run	Possible	Possible	Possible
ManCtl	Possible	Possible	Possible
StartAT	Possible	Possible	Possible
PV	Possible	Possible	Possible
SP	Possible	Possible	Not possible
MVLowLmt	Possible	Possible	Not possible

Variables	Control status		
	Instruction execution stopped*1	Automatic operation when autotuning is not being executed*2	Automatic operation when autotuning is being executed*3
MVUpLmt	Possible	Possible	Not possible
ManResetVal	Possible	Possible	Not possible
MVTrackSw	Possible	Possible	Not possible
MVTrackVal	Possible	Possible	Not possible
StopMV	Possible	Possible	Possible
ErrorMV	Possible	Possible	Possible
Alpha	Possible	Possible	Not possible
ATCalcGain	Possible	Possible	Not possible
ATHystrs	Possible	Possible	Not possible
SampTime	Possible	Not possible	Not possible
RngLowLmt	Possible	Not possible	Not possible
RngUpLmt	Possible	Not possible	Not possible
DirOpr	Possible	Not possible	Not possible
ProportionalBand	Possible	Possible	Not possible
IntegrationTime	Possible	Possible	Not possible
DerivativeTime	Possible	Possible	Not possible
ManMV	Possible	Possible	Possible

*1 *ManCtl* is TRUE, *Run* is FALSE, *Error* is TRUE, or *MVTrackSw* is TRUE.

*2 *ManCtl* is FALSE, *Run* is TRUE, *Error* is FALSE, *MVTrackSw* is FALSE, and *ATBusy* is FALSE.

*3 *ManCtl* is FALSE, *Run* is TRUE, *Error* is FALSE, *MVTrackSw* is FALSE, and *ATBusy* is TRUE.

- *SampTime* is truncated below 100 nanoseconds.
- If the value of *StartAT* changes to TRUE while the value of *ManCtl* is TRUE, autotuning starts the next time the value of *ManCtl* changes to FALSE.
- If the value of *ErrorMV* is not within the valid range (–320 to 320), the value of *MV* will be 0 when an error occurs.
- Autotuning is canceled if the value of *ManCtl* changes to TRUE during autotuning.
- The value of *Error* does not change to TRUE even if an error occurs during autotuning.
- An error occurs in the following case. *Error* will change to TRUE, and an error code is assigned to *ErrorID*. *ATDone* and *ATBusy* change to FALSE. *MV* is set to the value of *ErrorMV* if the values of *ManCtl* and *Run* are FALSE. If the value of *ErrorMV* is outside of the valid range, the value of *MV* is 0.

Error	Value of <i>ErrorID</i>
The value of an input variable is outside of the valid range.	16#0400
<i>RngLowLmt</i> is greater than or equal to <i>RngUpLmt</i> .	16#0401
<i>MVLowLmt</i> is greater than or equal to <i>MVUpLmt</i> .	

- If an error stop is required for conditions other than the above, program the system so that the value of *Run* changes to FALSE when the error occurs.
- If an error occurs because the value of *PV* or *SP* exceeds the valid range, the error status is maintained for five seconds even if the value returns to within the valid range sooner. That is, the value of *Error* will remain FALSE for five seconds.
- PID control is restarted automatically if the value of *Run* is TRUE after the error is reset. Autotuning is restarted automatically if the values of *Run* and *StartAT* are TRUE.
- A check is made for errors each sampling period.

Sample Programming

In this sample, the PIDAT instruction is used to perform temperature control. The manipulated variable of the PIDAT instruction is converted to a time-proportional value and output to a heating device. This sample uses a timer instruction to convert to a time-proportional value. To use the TimeProportionalOut instruction to convert to a time-proportional value, refer to the sample programming that is provided for the TimeProportionalOut instruction (page 2-729).

Specifications

Temperature control is performed according to the following specifications.

Item	Specification
Input type	K thermocouple
Input Unit	CJ1W-PH41U Isolated-type Universal Input Unit
Output Unit	CJ1W-OD212 Transistor Output Unit
Set point	90°C
Sampling period for PID control	100 ms
Output control period	1 s

Configuration and Settings

The following setting is used for the CJ1W-PH41U Input Unit.

Setting	Set value
Input1:Input signal type	K(1)

The following I/O map settings are used.

Unit	I/O port	Description	Variable
CJ1W-PH41U	Ch1_AllnPV	Process value for input 1 (INT data)	AI1
CJ1W-OD212	Ch1_Out00	Bit 00 of output word 1	DO1

Processing

- The manipulation value MV of the PIDAT instruction is obtained to control the output to the temperature controller. The output to the temperature controller is turned ON and OFF.
- The sampling period (*InitSetParams.SampTime*) of the PIDAT instruction is set to 100 ms. The task period must be sufficiently shorter than 100 ms. Therefore, the value of MV is refreshed every 100 ms.
- The output control period is 1 s. During that period, the ON time and OFF time of the output control value are controlled with a time-proportional output. For example, if the obtained value of MV is 20%, the output to the temperature control is ON for 200 ms and OFF for 800 ms. This is repeated at a 1-s period.

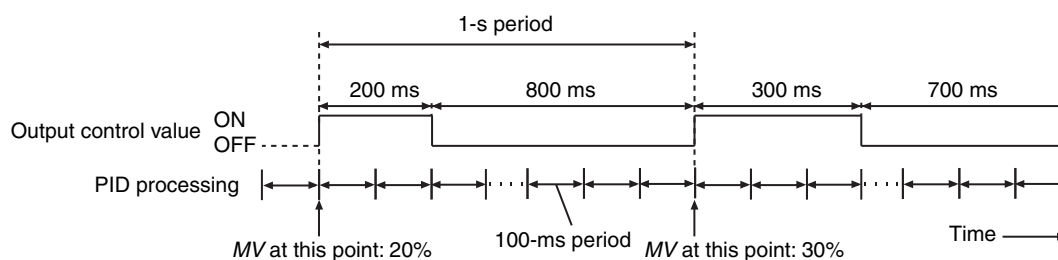

- If the most recent value of *MV* is smaller than the value of *MV* when the output control values were determined, the output control values do not change. If the most recent value of *MV* is larger than the value of *MV* when the output control values were determined, the most recent value is immediately reflected in the output control values. For example, assume that the output control values were determined when the value of *MV* was 20% (ON 200 ms, OFF 800 ms). If after 100 ms, the new value of *MV* is 30%, the output control values are immediately changed to turn the output ON for 300 ms and OFF for 700 ms.

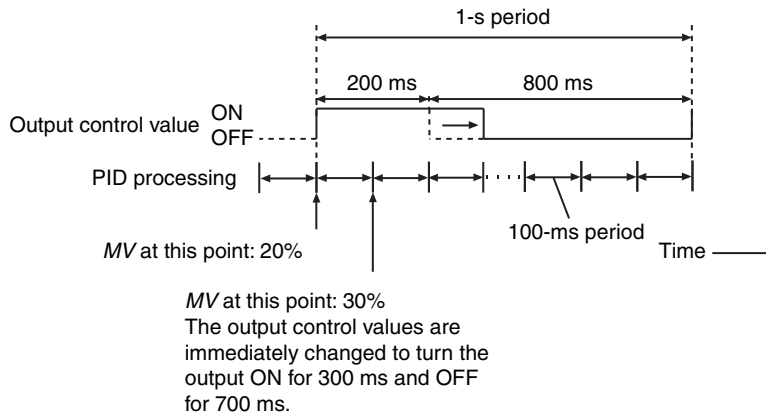

- If autotuning is performed and the value of *MV* is 100%, the output is immediately turned ON regardless of the control period.

Application Programming

LD

Variable	Data type	Initial value	Retain	Comment
Run1	BOOL	FALSE		Execution condition
ManCtl1	BOOL	FALSE		Manual/auto control
StartAT1	BOOL	FALSE		Autotuning execution condition
PV1	REAL	0.0		Process value
SP1	REAL	90		Set point
OprSetParams1	_sOPR_SET_PARAMS	(MVLowlmt:=0.0, MVUpLmt:=100.0, ManResetVal:=0.0, MVTrackSw:=FALSE, MVTrackVal:=0.0, StopMV:=0.0, ErrorMV:=0.0, Alpha:=0.65, ATCalcGain:=1.0, ATHystrs:=0.2)		Operation setting parameters
InitSetParams1	_sINIT_SET_PARAMS	(SampTime:=T#100ms, RngLowLmt:=0.0, RngUpLmt:=1000.0, DirOpr:=FALSE)		Initial setting parameters
PB1	REAL	10	✓	Proportional band
TI1	TIME	T#0S	✓	Integration time
TD1	TIME	T#0S	✓	Derivative time
ManMV1	REAL	0.0		Manual manipulated variable
ATDone1	BOOL	FALSE		Autotuning normal completion
ATBusy1	BOOL	FALSE		Executing autotuning
Error1	BOOL	FALSE		Error

Variable	Data type	Initial value	Retain	Comment
ErrorID1	WORD	16#0		Error ID
MV1	REAL	0.0		Manipulated variable
PulseOnTime	TIME	T#0s		Control output ON time
PulseCycTime	TIME	T#1s		Control period
ResetPulse	BOOL	FALSE		Timer reset
PIDAT_instance	PIDAT			
TOF_instance	TOF			
TON_instance	TON			

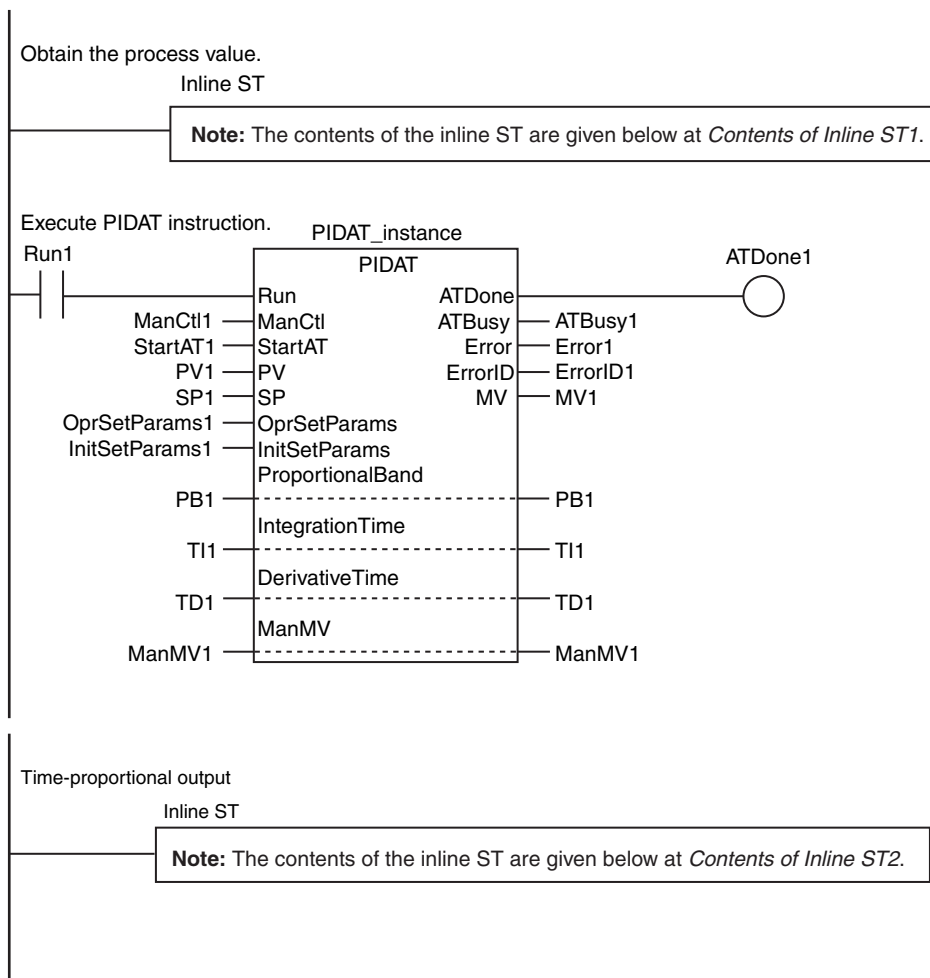

Contents of Inline ST1

```
PV1:=INT_TO_REAL(AI1)/REAL#10.0; // Convert PV AI1 to real number.
// CJ1W-PH41U output is ten times the process value, so divide by 10.0.
```

Contents of Inline ST2

```
PulseOnTime:=MULTIME(PulseCycTime, MV1/REAL#100.0); // Calculate ON time output control value.
TOF_instance(In:=BOOL#FALSE, PT:=PulseOnTime, Q=>DO1); // Switch between ON and OFF with TOF instruction.
TON_instance(In:=BOOL#TRUE, PT:=PulseCycTime, Q=>ResetPulse); // Measure timer reset time with TON instruction.
IF (ResetPulse=BOOL#TRUE) THEN // Reset timer.
    TOF_instance(In:=BOOL#TRUE);
    TON_instance(In:=BOOL#FALSE);
END_IF;
IF ( (ATBusy1=BOOL#TRUE) & (MV1=REAL#100.0) ) THEN // If MV1 = 100% for autotuning...
    DO1:=BOOL#TRUE; // Turn ON the output immediately.
END_IF;
```

ST

Variable	Data type	Initial value	Retain	Comment
Run1	BOOL	FALSE		Execution condition
ManCtl1	BOOL	FALSE		Manual/auto control
StartAT1	BOOL	FALSE		Autotuning execution condition
PV1	REAL	0.0		Process value
SP1	REAL	90		Set point
OprSetParams1	_sOPR_SET_PARAMS	(MVLowLmt:=0.0, MVUpLmt:=100.0, ManResetVal:=0.0, MVTrackSw:=FALSE, MVTrackVal:=0.0, StopMV:=0.0, ErrorMV:=0.0, Alpha:=0.65, ATCalcGain:=1.0, ATHystrs:=0.2)		Operation setting parameters
InitSetParams1	_sINIT_SET_PARAMS	(SampTime:=T#100ms, RngLowLmt:=0.0, RngUpLmt:=1000.0, DirOpr:=FALSE)		Initial setting parameters
PB1	REAL	10	✓	Proportional band
TI1	TIME	T#0S	✓	Integration time
TD1	TIME	T#0S	✓	Derivative time
ManMV1	REAL	0.0		Manual manipulated variable
ATDone1	BOOL	FALSE		Autotuning normal completion
ATBusy1	BOOL	FALSE		Executing autotuning
Error1	BOOL	FALSE		Error
ErrorID1	WORD	16#0		Error ID
MV1	REAL	0.0		Manipulated variable
PulseOnTime	TIME	T#0s		Control output ON time
PulseCycTime	TIME	T#1s		Control period
ResetPulse	BOOL	FALSE		Timer reset
PIDAT_instance	PIDAT			
TOF_instance	TOF			
TON_instance	TON			

```
// Convert PV AI1 to real number.
PV1:=INT_TO_REAL(AI1)/REAL#10.0; // CJ1W-PH41U output is ten times the process value, so divide by 10.0.
```

```
// Execute PIDAT instruction.
PIDAT_instance(
  Run           :=Run1,
  ManCtl        :=ManCtl1,
  StartAT       :=StartAT1,
  PV            :=PV1,
  SP            :=SP1,
  OprSetParams  :=OprSetParams1,
  InitSetParams :=InitSetParams1,
  ProportionalBand :=PB1,
  IntegrationTime :=TI1,
  DerivativeTime :=TD1,
  ManMV         :=ManMV1,
  ATDone        =>ATDone1,
  ATBusy        =>ATBusy1,
```

```
Error          =>Error1,
ErrorID        =>ErrorID1,
MV             =>MV1);

// Time-proportional output
PulseOnTime:=MULTIME(PulseCycTime, MV1/REAL#100.0);
// Calculate ON time output control value.
TOF_instance(In:=BOOL#FALSE, PT:=PulseOnTime, Q=>DO1);
// Switch between ON and OFF with TOF instruction.
TON_instance(In:=BOOL#TRUE, PT:=PulseCycTime, Q=>ResetPulse);
// Measure timer reset time with TON instruction.
IF (ResetPulse=BOOL#TRUE) THEN           // Reset timer.
    TOF_instance(In:=BOOL#TRUE);
    TON_instance(In:=BOOL#FALSE);
END_IF;
IF ( (ATBusy1=BOOL#TRUE) & (MV1=REAL#100.0) ) THEN // If MV1 = 100% for autotuning...
    DO1:=BOOL#TRUE;                          // Turn ON the output immediately.
END_IF;
```

PIDAT_HeatCool

The PIDAT_HeatCool instruction performs heating/cooling PID control with autotuning (2-PID control with set point filter).

Instruction	Name	FB/ FUN	Graphic expression	ST expression
PIDAT_HeatCool	Heating/Cooling PID with Autotuning	FB		<pre>PIDAT_HeatCool_instance(Run, ManCtl, StartAT, PV, SP, DeadBand, OprSetParams, InitSetParams, ProportionalBand_Heat, IntegrationTime_Heat, DerivativeTime_Heat, ProportionalBand_Cool, IntegrationTime_Cool, DerivativeTime_Cool, ManMV, CtlPrd_Cool, ATDone, ATBusy, Error, ErrorID, MV, MV_Heat, MV_Cool);</pre>

Variables

Name	Meaning	I/O	Description	Valid range	Unit	Default
Run	Execution condition	Input	TRUE: Execute FALSE: Stop	Depends on data type.	---	FALSE
ManCtl	Manual/auto control		TRUE: Manual operation FALSE: Automatic operation			
StartAT	Autotuning execution condition		TRUE: Execute FALSE: Cancel			
PV	Process value		Process value	*1	0	
SP	Set point		Set point			
DeadBand	Deadband		Deadband/overlap band setting	-320.0 to 320.0	%	
OprSet Params	Operation setting parameters		Parameters set during operation	---	---	---
InitSet Params	Initial setting parameters		Initial setting parameters			
CtlPrd_Cool	Cooling control period		Control period when time-proportional output is used for <i>MV_Cool</i>	T#0.1s to T#100s		T#20s
Proportional Band_Heat	Proportional band for heating control	In-out	Proportional band for heating control	0.01 to 1000.00	%FS	---
Integration-Time_Heat	Integration time for heating control		Integration time for heating control The higher the value is, the weaker the integral action is. No integral action is performed for 0.	T#0.0000s to T#10000.0000s *2	s	
Derivative Time_Heat	Derivative time for heating control		Derivative time for heating control The higher the value is, the stronger the derivative action is. No derivative action is performed for 0.	T#0.0000s to T#10000.0000s *2		
Proportional Band_Cool	Proportional band for cooling control		Proportional band for cooling control	0.01 to 1000.00	%FS	
Integration-Time_Cool	Integration time for cooling control		Integration time for cooling control The higher the value is, the weaker the integral action is. No integral action is performed for 0.	T#0.0000s to T#10000.0000s *2	s	
Derivative Time_Cool	Derivative time for cooling control		Derivative time for cooling control The higher the value is, the stronger the derivative action is. No derivative action is performed for 0.	T#0.0000s to T#10000.0000s *2		
ManMV	Manual manipulated variable		Manual manipulated variable	-320 to 320	%	

Name	Meaning	I/O	Description	Valid range	Unit	Default
ATDone	Autotuning normal completion	Output	TRUE: Normal completion FALSE: *3	Depends on data type.	---	---
ATBusy	Autotuning busy		TRUE: Autotuning FALSE: Not autotuning			
MV	Manipulated variable		Manipulated variable			
MV_Heat	Manipulated variable for heating control		Manipulated variable for heating control	0 to 320	%	
MV_Cool	Manipulated variable for cooling control		Manipulated variable for cooling control	0 to 320		

*1 Value of input range lower limit *InitSetParams.RngLowLmt* to Value of input range upper limit *InitSetParams.RngUpLmt*

*2 Digits below 0.0001 s are truncated.

*3 FALSE indicates an error end, that PID control is in progress without autotuning, or that PID control is not in progress.

	Boolean	Bit strings				Integers							Real numbers		Times, durations, dates, and text strings					
	BOOL	BYTE	WORD	DWORD	LWORD	USINT	UINT	UDINT	ULINT	SINT	INT	DINT	LINT	REAL	LREAL	TIME	DATE	TOD	DT	STRING
Run	OK																			
ManCtl	OK																			
StartAT	OK																			
PV														OK						
SP														OK						
DeadBand														OK						
OprSet Params	Refer to <i>Function</i> for details on the structure <i>_sOPR_SET_PARAMS</i> .																			
InitSet Params	Refer to <i>Function</i> for details on the structure <i>_sINIT_SET_PARAMS</i> .																			
CtlPrd_Cool																OK				
Proportional Band_Heat														OK						
Integration-Time_Heat																OK				
Derivative Time_Heat																OK				
Proportional Band_Cool														OK						
Integration-Time_Cool																OK				
Derivative Time_Cool																OK				
ManMV														OK						
ATDone	OK																			

	Boolean	Bit strings				Integers							Real numbers		Times, durations, dates, and text strings					
	BOOL	BYTE	WORD	DWORD	LWORD	USINT	UINT	UDINT	ULINT	SINT	INT	DINT	LINT	REAL	LREAL	TIME	DATE	TOD	DT	STRING
ATBusy	OK																			
MV														OK						
MV_Heat														OK						
MV_Cool														OK						

Function

The PIDAT_HeatCool instruction performs heating/cooling PID control of a manipulated variable for a temperature controller or other device.

Heating/cooling PID control is started when the value of execution condition *Run* changes to TRUE. While the value of *Run* is TRUE, the following process is repeated periodically: process value *PV* is read, heating/cooling PID processing is performed, and manipulated variable for heating *MV_Heat* and manipulated variable for cooling *MV_Cool* are output.

Heating/cooling PID control is stopped when the value of *Run* changes to FALSE.

Autotuning is supported to automatically find the optimum PID constants for heating control and for cooling control.

When the value of the autotuning execution condition *StartAT* changes to TRUE, the PID constants for heating control and cooling control are autotuned.

Difference between the PIDAT_HeatCool and PIDAT Instructions

● PIDAT_HeatCool Instruction

The PIDAT_HeatCool instruction uses both a heating device and a cooling device to control the temperature. Therefore, manipulated variables are output for two different control operations: the manipulated variable for heating control, *MV_Heat*, and the manipulated variable for cooling control, *MV_Cool*. Autotuning finds the optimum PID constants for heating control and the optimum PID constants for cooling control.

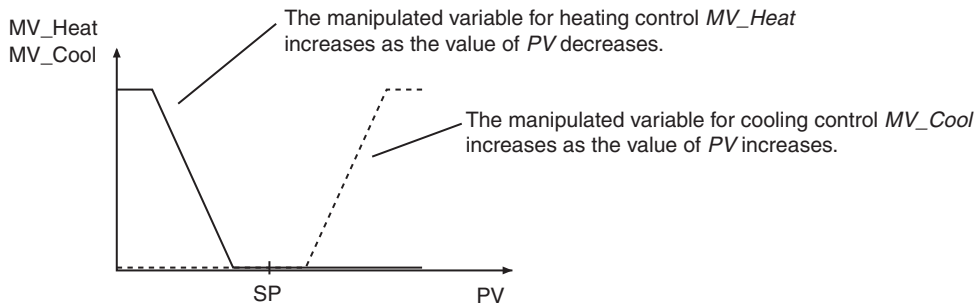

● PIDAT Instruction

The PIDAT instruction uses either a heating device or a cooling device to control the temperature. Therefore, only one manipulated variable (*MV*) is output. Also, there is a parameter, action direction *DirOpr*, that determines whether the manipulated variable is output to a heating device or to a cooling device. The PIDAT_HeatCool instruction does not use *DirOpr*.

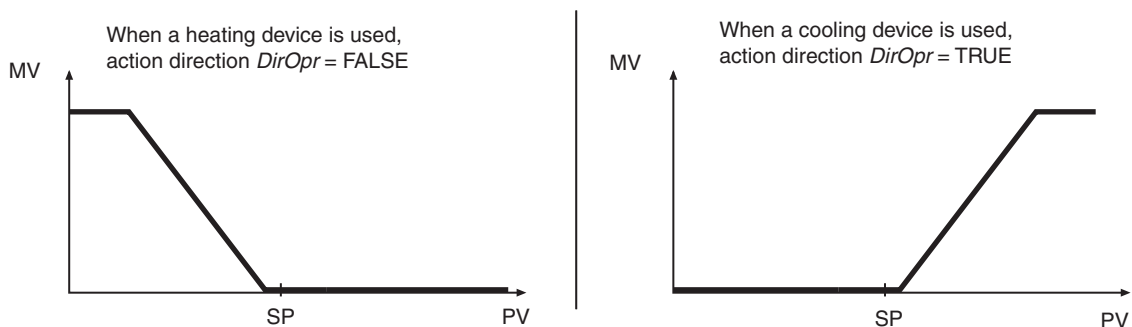

Manipulated Variable *MV* Compared with Manipulated Variable for Heating Control *MV_Heat* and Manipulated Variable for Cooling Control *MV_Cool*

MV is the manipulated variable for an instruction like the PIDAT instruction that uses either a heating device or a cooling device to control the temperature. The PIDAT_HeatCool instruction also calculates *MV* in the same way as the PIDAT instruction. *MV* is then distributed to the manipulated variable for heating and the manipulated variable for cooling. The following figure shows conceptually how the value of *MV* is distributed to *MV_Heat* and *MV_Cool*. The value of *MV_Cool* is the absolute value of *MV* when *MV* is negative.

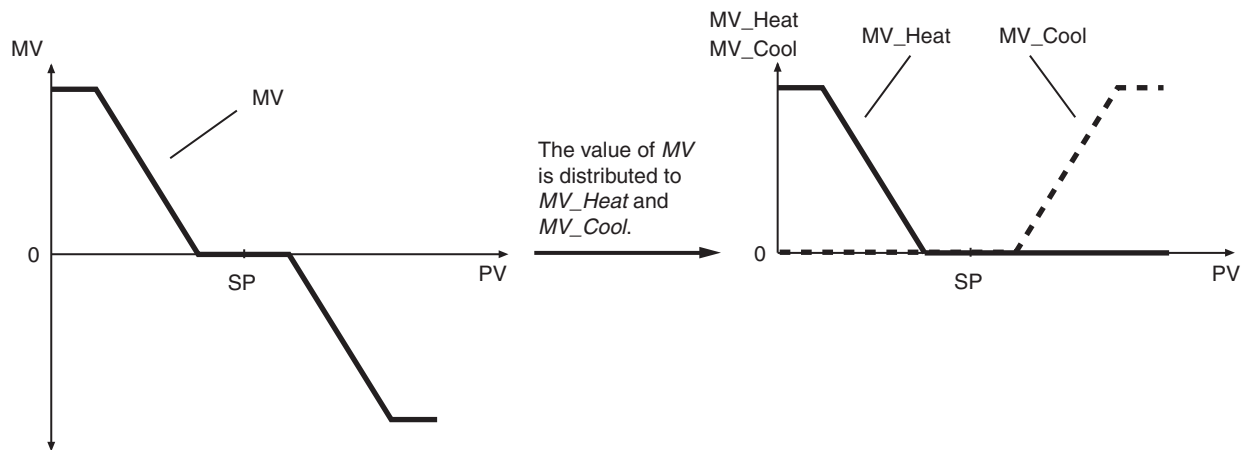

The above figure is conceptual. The actual values of *MV_Heat* and *MV_Cool* are not exactly the negative and positive values of *MV*. The values of *MV_Heat* and *MV_Cool* are calculated from special formulas based on the value of *MV*.

Structure Specifications

The data type of operation setting parameter *OprSetParams* is structure *_sOPR_SET_PARAMS*. The specifications are as follows:

Name	Meaning	Description	Data type	Valid range	Unit	Default
OprSetParams	Operation Setting Parameters	Parameters that are set during operation.	_sOPR_SET_PARAMS	---	---	---
MVLowLmt	MV Lower Limit	Lower limit of <i>MV_Heat</i> and <i>MV_Cool</i>	REAL	-320 to 320* ¹	%	-100
MVUpLmt	MV Upper Limit	Upper limit of <i>MV_Heat</i> and <i>MV_Cool</i>	REAL			100
ManResetVal	Manual Reset Value	Not used.	REAL			-320 to 320
MVTrackSw	MV Tracking Switch	MV Tracking Switch TRUE: ON FALSE: OFF	BOOL	Depends on data type.	---	FALSE
MVTrackVal	MV Tracking Value	The value that is set in <i>MV</i> during <i>MV</i> tracking.	REAL	-320 to 320	%	0
StopMV	Stop MV	The value that is set in <i>MV</i> when instruction execution is stopped.	REAL			
ErrorMV	Error MV	The value that is set in <i>MV</i> when an error occurs.	REAL			
Alpha	2-PID Parameter α	The set point filter is disabled if the set point filter coefficient α is 0.	REAL	0.00 to 1.00	---	0.65
ATCalcGain	Autotuning Calculation Gain	Adjustment coefficient from autotuning results. Stability is given higher priority with higher values. The speed of response is given higher priority with lower values.	REAL	0.1 to 10.0		0.8
ATHystrs	Autotuning Hysteresis	The hysteresis of the limit cycle.	REAL	0.01 to 10.0		%FS

*1 *MVLowLmt* must be less than *MVUpLmt*.

The data type of initial setting parameter *InitSetParams* is structure `_sINIT_SET_PARAMS`. The specifications are as follows:

Name	Meaning	Description	Data type	Valid range	Unit	Default
InitSetParams	Initial Setting Parameters	Initial setting parameters.	<code>_sINIT_SET_PARAMS</code>	---	---	---
SampTime	Sampling Period	The period for PID processing.	TIME	T#0.0001s to #100.0000s	s	T#0.05s
RngLowLmt	Lower Limit of Input Range	The lower limit of <i>PV</i> and <i>SP</i> .	REAL	-32000 to 32000* ¹	---	0
RngUpLmt	Upper Limit of Input Range	The upper limit of <i>PV</i> and <i>SP</i> .	REAL			100
DirOpr	Action Direction	Not used.	BOOL	Depends on data type.		FALSE

*1 *RngLowLmt* must be less than *RngUpLmt*.

Meanings of Variables

The meanings of the variables that are used in this command are described below.

● *Run* (Execution Condition)

This is the execution condition for the instruction.

Heating/cooling PID control is performed while the value is TRUE. Heating/cooling PID control is stopped when the value changes to FALSE.

● *ManCtl* (Manual/Auto Control)

This instruction can be executed in one of two modes: Manual operation or automatic operation. The value of *ManCtl* determines which mode is used.

Value of <i>ManCtl</i>	Operation mode	Value of <i>MV</i>
TRUE	Manual	Value of <i>ManMV</i> (Heating/cooling PID control is not performed.)
FALSE	Automatic	Value that is calculated for heating/cooling PID control

● *StartAT* (Autotuning Execution Condition)

This is the execution condition for autotuning the PID constants.

If the value of *StartAT* is TRUE when the value of *Run* changes to TRUE, autotuning is performed when PID control is started.

If the value of *StartAT* changes to TRUE during heating/cooling PID control (i.e., when the value of *Run* is TRUE), autotuning is performed during heating/cooling PID control.

In either case, autotuning is canceled if the value of *StartAT* changes to FALSE during autotuning. Autotuning is described in more detail later.

● *PV* (Process Value)

This is the process value of the controlled system.

● *SP* (Set Point)

This is the set point for the controlled system.

● **DeadBand (Deadband)**

DeadBand determines how the value of *MV* is distributed to *MV_Heat* and *MV_Cool*. *DeadBand* gives the range of the value of *MV* centered on an *MV* value of 0 within which both heating and cooling control operations are not performed.

The following table and figure show the relationship between the value of *MV* and the values of *MV_Heat* and *MV_Cool*.

Value of <i>MV</i>	Value of <i>MV_Heat</i>	Value of <i>MV_Cool</i>
Within the deadband	0	0
Larger than the deadband	0	Positive. Increases as the value of <i>MV</i> increases.
Smaller than the deadband	Positive. Increases as the value of <i>MV</i> decreases.	0

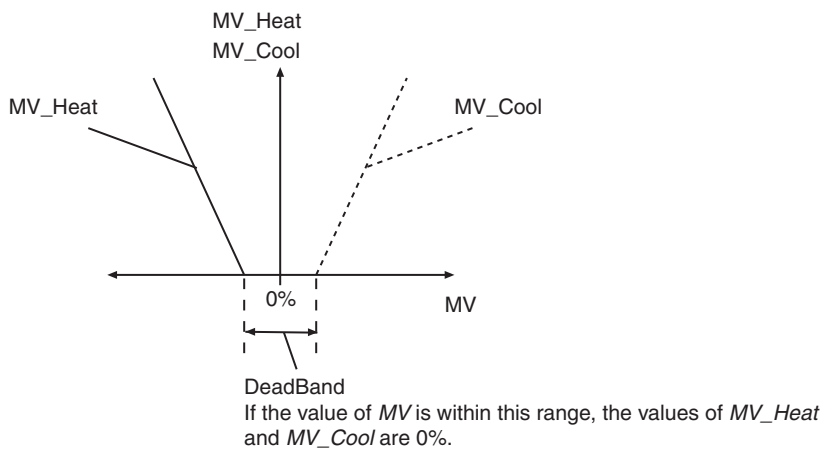

You can also set a negative value for *DeadBand*. If the value of *DeadBand* is negative while the value of *MV* is within the deadband, both heating and cooling control are performed. The following table and figure show the relationship between the value of *MV* and the values of *MV_Heat* and *MV_Cool* when the value of *DeadBand* is negative.

Value of <i>MV</i>	Value of <i>MV_Heat</i>	Value of <i>MV_Cool</i>
Within the deadband	Positive. Increases as the value of <i>MV</i> decreases.	Positive. Increases as the value of <i>MV</i> increases.
Larger than the deadband	0	Positive. Increases as the value of <i>MV</i> increases.
Smaller than the deadband	Positive. Increases as the value of <i>MV</i> decreases.	0

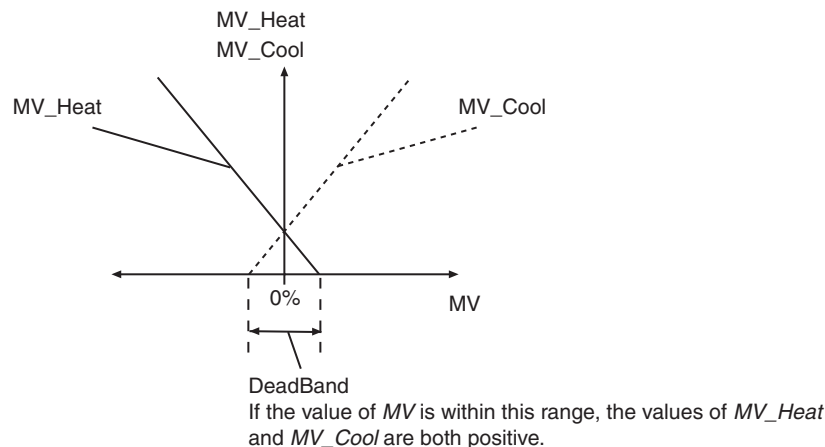

● **MVLowLmt (MV Lower Limit) and MVUpLmt (MV Upper Limit)**

You can limit the values of *MV_Heat* and *MV_Cool*. The upper and lower limits of *MV_Heat* and *MV_Cool* are determined by *MVLowLmt* and *MVUpLmt*. The following procedure is used to find the values of *MV_Heat* and *MV_Cool*.

- 1** The heating/cooling PID processing is performed to find *MV*. The upper and lower limits of *MV* are calculated from special formulas based on *MVLowLmt* and *MVUpLmt*.
- 2** *MV_Heat* and *MV_Cool* are found by distributing *MV*.

The following figure shows the relationship between *MV*, *MV_Heat*, and *MV_Cool* when *MVLowLmt* is -100 and *MVUpLmt* is 200. The calculated upper limit of *MV_Heat* is 200 and the calculated lower limit is 0. The calculated upper limit of *MV_Cool* is 100 and the calculated lower limit is 0. In other words, the upper limit of *MV_Heat* is the same as the value of *MVUpLmt*, but the upper limit of *MV_Cool* is the absolute value of *MVLowLmt*.

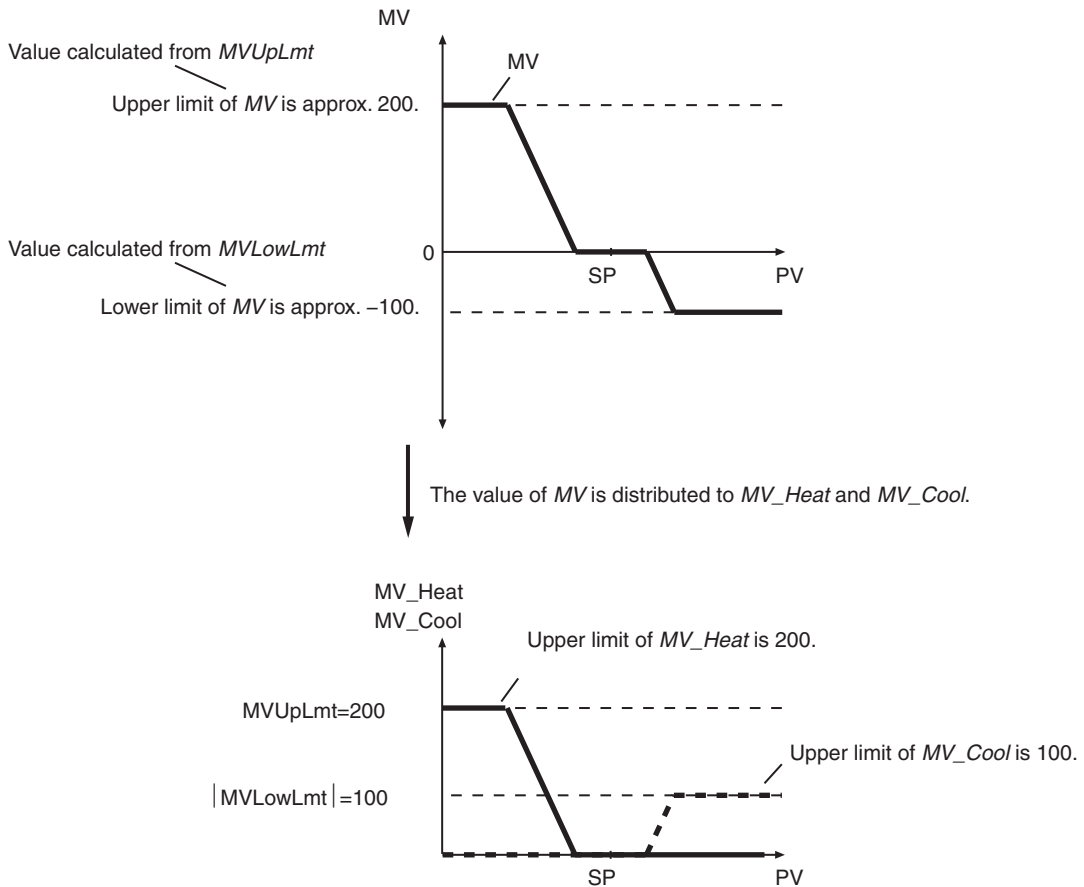

The following figure shows the relationship between *MV*, *MV_Heat*, and *MV_Cool* when *MVLowLmt* is 100 and *MVUpLmt* is 200. The calculated upper limit of *MV_Heat* is 200 and the calculated lower limit is 100. The value of *MV_Cool* is always 0. In other words, the upper and lower limits of *MV_Heat* are the same as *MVUpLmt* and *MVLowLmt*.

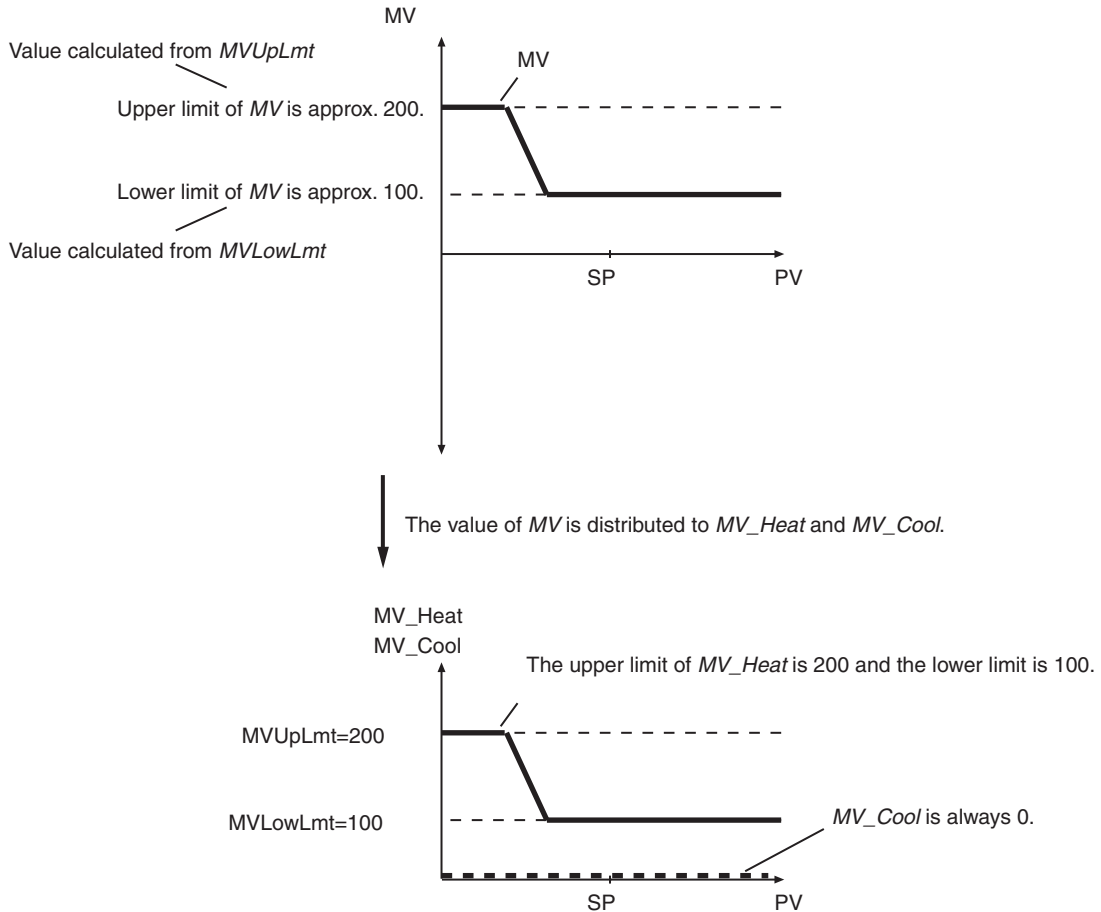

As shown above, the upper and lower limits of *MV_Heat* and *MV_Cool* change as shown in the following table depending on whether *MVLowLmt* and *MVUpLmt* are positive values or negative values.

Value of <i>MVLowLmt</i>	Value of <i>MVUpLmt</i>	<i>MV_Heat</i>		<i>MV_Cool</i>	
		Lower limit	Upper limit	Lower limit	Upper limit
Positive	Positive	<i>MVLowLmt</i>	<i>MVUpLmt</i>	0	0
Negative	Positive	0	<i>MVUpLmt</i>	0	Absolute value of <i>MVLowLmt</i>
Negative	Negative	0	0	Absolute value of <i>MVUpLmt</i>	Absolute value of <i>MVLowLmt</i>

Always set *MVLowLmt* and *MVUpLmt* so that *MVLowLmt* is less than *MVUpLmt*. Also, if *MV* is set to *StopMV*, *ErrorMV*, or *ManMV*, limit control is not applied.

You can change *MVLowLmt* and *MVUpLmt* even if the control status of this instruction is not auto-tuning during automatic operation.

However, if you change *MVLowLmt* or *MVUpLmt* to an expansion direction during operation, the value of *MV_Heat* or *MV_Cool* which is the same as one in the last sampling period is output and changed smoothly at this time (bumpless).

Repeated changing of *MVLowLmt* or *MVUpLmt* will affect the control performance so that sufficient control performance may not obtain.

Confirm the effects on the control performance before you repeatedly change *MVLowLmt* or *MVUpLmt* during operation.

- **ManResetVal (Manual Reset Value)**

This instruction does not use this variable. Any value that is set is ignored.

- **MVTrackSw (MV Tracking Switch)**

MV tracking is a function that sets the *MV* to an external input value (called the MV tracking value) during automatic operation.

MV tracking is performed while the value of *MVTrackSw* is TRUE.

When the value of *MVTrackSw* changes to FALSE, the value of *MV* returns to the result of heating/cooling PID processing. At this time, the value of *MV* takes on the value of *MVTrackVal*. This prevents the values of *MV_Heat* and *MV_Cool* from changing abruptly.

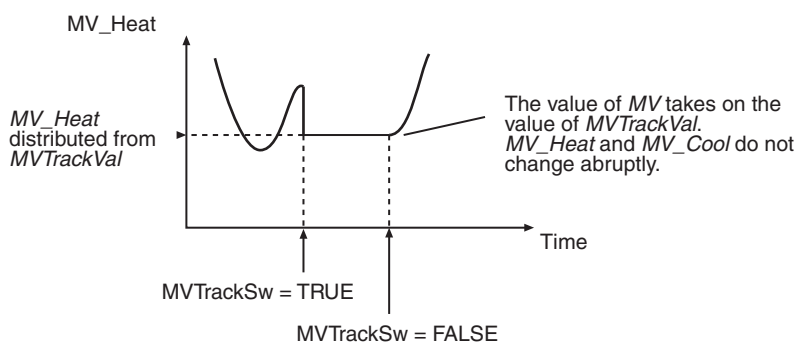

- **MVTrackVal (MV Tracking Value)**

This is the value to which *MV* is set during MV tracking. The value of *MVTrackVal* is limited by the values of *MVLowLmt* and *MVUpLmt*.

- **StopMV (Stop MV)**

This is the value to which *MV* is set when the value of *Run* is FALSE (i.e., when execution of this instruction is stopped).

- **ErrorMV (Error MV)**

This is the value to which *MV* is set when an error occurs (i.e., when the value of *Error* is TRUE). If the value of *ErrorMV* is not within the valid range (–320 to 320), the value of *MV* will be 0 when an error occurs.

- **Alpha (2-PID Parameter α)**

This parameter determines the coefficient of the set point filter.

Refer to the description in 2-PID Control with Set Point Filter in the section on the PIDAT instruction (page 2-666) for details.

Normally set the value of *Alpha* to 0.65.

- **ATCalcGain (Autotuning Calculation Gain)**

This variable gives the coefficient of the PID constants that were calculated by autotuning when they are applied to the actual PID constants. If a value of 1.00 is specified, the results of autotuning are used directly. Increase the value of *ATCalcGain* to give priority to stability and decrease it to give priority to response.

- **ATHystrs (Autotuning Hysteresis)**

This is the hysteresis that is used in the limit cycle for autotuning. More accurate tuning is achieved if the value of *ATHystrs* is small. However, if the process value is not stable and proper autotuning is difficult, increase the value.

Refer to the description of autotuning in the section on the PIDAT instruction (page 2-666) for details.

- **SampTime (Sampling Period)**

This is the minimum value of the period for heating/cooling PID processing.

Refer to the description of the execution timing of heating/cooling PID processing for details. Heating/cooling PID processing is not performed again until the time specified for *SampTime* has elapsed since the last time heating/cooling PID processing was performed.

- **RngLowLmt (Lower Limit of Input Range) and RngUpLmt (Upper Limit of Input Range)**

These are the lower limit and upper limit of *PV* and *SP*. An error will occur if the value of the parameter connected to *PV* or *SP* exceeds either of these limits. *RngLowLmt* must always be less than *RngUpLmt*.

- **DirOpr (Action Direction)**

This instruction does not use this variable. Any value that is set is ignored.

- **CtlPrd_Cool (Control Period)**

This variable sets the control period for time-proportional output of *MV_Cool* when you use this instruction together with the TimeProportionalOut instruction (page 2-729). Set the same value here and for control period *CtlPrd* of the TimeProportionalOut instruction.

If you do not use time-proportional output for *MV_Cool*, set the default value, T#20s.

- **ProportionalBand_Heat and ProportionalBand_Cool (Proportional Bands)**

This is one of the three PID constants. Refer to the description of the proportional action in the section on the PIDAT instruction (page 2-666) for details.

If the values of *ProportionalBand_Heat* and *ProportionalBand_Cool* are large, the offset will be large. Hunting occurs if a proportional band is too small.

- **IntegrationTime_Heat and IntegrationTime_Cool (Integration Times)**

This is one of the three PID constants. Refer to the description of the integral action in the section on the PIDAT instruction (page 2-666) for details.

The larger the value of *IntegrationTime_Heat* or *IntegrationTime_Cool* is, the weaker the integral action is.

- **DerivativeTime_Heat and DerivativeTime_Cool (Derivative Times)**

This is one of the three PID constants. Refer to the description of the derivative action in the section on the PIDAT instruction (page 2-666) for details.

The larger the value of *DerivativeTime_Heat* or *DerivativeTime_Cool* is, the stronger the derivative action is.

- **ManMV (Manual Manipulated Variable)**

MV is set to this value during manual operation (while *ManCtl* is TRUE).

However, *MV* is set to the value of *ManMV* only when it changes after operation switches to manual operation.

The value of *MV* immediately after changing from automatic to manual operation will be the value of *MV_Heat* if that value is positive and the value of *MV_Cool* otherwise.

Also, the value of *MV* immediately after changing from manual to automatic operation will be the value of *MV_Heat* if that value is positive and the value of *MV_Cool* otherwise.

The value of *ManMV* does not have to be between *MVLowLmt* and *MVUpLmt*.

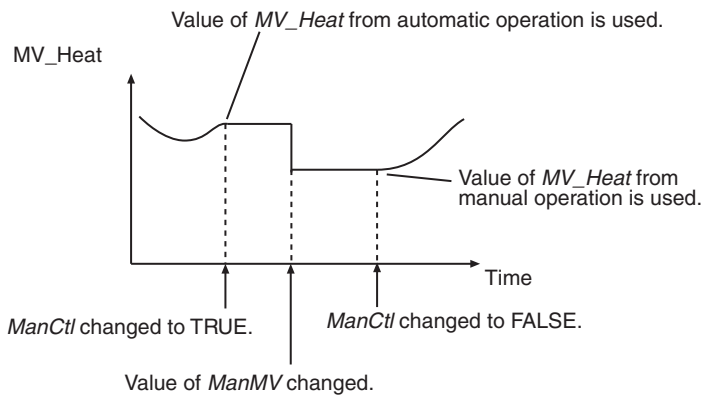

● **ATDone (Autotuning Normal Completion)**

This flag indicates when autotuning was completed normally. It changes to TRUE when autotuning is completed normally and remains TRUE as long as the value of *StartAT* is TRUE. It is FALSE in the following cases.

- An autotuning error end occurred.
- Autotuning is in progress (i.e., while the value of *ATBusy* is TRUE).
- Heating/cooling PID control is in progress without autotuning.
- Heating/cooling PID control is not in progress (i.e., the value of *Run* is FALSE).
- The value of *StartAT* is FALSE.

● **ATBusy (Autotuning Busy)**

This flag indicates when autotuning is in progress. It is TRUE while autotuning is in progress. Otherwise it is FALSE.

● **MV (Manipulated Variable)**

This is the manipulated variable found by the heating/cooling PID processing. *MV_Heat* and *MV_Cool* are found by distributing *MV*.

● **MV_Heat (Manipulated Variable for Heating Control)**

This is the manipulated variable that is applied to the heating device.

● **MV_Cool (Manipulated Variable for Cooling Control)**

This is the manipulated variable that is applied to the cooling device.

Heating/Cooling PID Processing

Refer to the section on the PIDAT instruction (page 2-666) for details on PID processing.

Heating/cooling PID processing is used to find the manipulated variables using the PID constants for heating control and the PID constants for cooling control. If *MV* is less than or equal to 0 in the previous processing results, the PID constants for heating control are used. If the previous *MV* is greater than 0, the PID constants for cooling control are used.

Proportional (P), Integral (I), and Derivative (D) Actions

Refer to the section on the PIDAT instruction (page 2-666) for details on the proportional action (P), integral action (I), and derivative action (D).

2-PID Control with Set Point Filter

Refer to the description in 2-PID Control with Set Point Filter in the section on the PIDAT instruction (page 2-666) for details.

Heating/Cooling PID with Autotuning

You must use the optimum PID constants to execute this instruction. There are the following two ways to achieve this.

● When Optimum PID Constants Are Not Known

If you do not know the optimum PID constants, perform autotuning at the start of operation to find them. Change the value of *Run* to TRUE while the value of *StartAT* is TRUE. First, autotuning is executed, and then heating/cooling PID control is started with the PID constants that are found.

● When Optimum PID Constants Are Known

Set *ProportionalBand_Heat*, *IntegrationTime_Heat*, *DerivativeTime_Heat*, *ProportionalBand_Cool*, *IntegrationTime_Cool*, and *DerivativeTime_Cool* to the optimum PID constants and then change the value of *Run* to TRUE.

ProportionalBand_Heat, *IntegrationTime_Heat*, *DerivativeTime_Heat*, *ProportionalBand_Cool*, *IntegrationTime_Cool*, and *DerivativeTime_Cool* are in-out variables. You cannot set constants for the input parameters. Always define suitable variables, and then assign the values to input parameters.

You can change the PID constants during operation. You can also perform autotuning during operation. To start autotuning during operation, change the value of *StartAT* to TRUE.

Control Status and Manipulated Variable

Manipulated variable *MV* is determined according to the control status as shown in the following table.

Control status	Value of variable					Manipulated variable <i>MV</i>	
	<i>ManCtl</i> (manual/auto control)	<i>Run</i> (execution condition)	<i>Error</i> (error end)	<i>MVTrackSw</i> (MV tracking switch)	<i>ATBusy</i> (autotuning busy)		
Error end	FALSE	TRUE	TRUE	---	FALSE	<i>ErrorMV</i> (error MV)	
MV tracking during automatic operation			FALSE	TRUE		FALSE	<i>MVTrackVal</i> (MV tracking value)
Autotuning during automatic operation			FALSE	FALSE	FALSE	TRUE	Value repeatedly changes between upper limit of MV and lower limit of MV.
Not autotuning during automatic operation			FALSE	FALSE	---	FALSE	Value calculated with current PID constants.
Instruction execution stopped			FALSE	---	---	---	<i>StopMV</i> (Stop MV)*1
Manual operation	TRUE	---	---	---	<i>ManMV</i> (manual manipulated variable)*2		

*1 If the value of *StopMV* is outside of the valid range, the value of *MV* is 0.

*2 If the value of *ManMV* is outside of the valid range, the value of *MV* is 0.

Autotuning

The 2-PID parameter α is not adjusted very often, so the main parameters that are adjusted for this instruction are the PID constants.

The PIDAT instruction supports autotuning of the PID constants. The limit cycle method is used for autotuning. With the limit cycle method, the manipulated variable is temporarily changed to the upper and lower limits of the limit cycle manipulated variable to find the optimum PID constants based on the resulting changes in the process value.

When you start execution of autotuning, the manipulated variable is first set to the upper limit of the limit cycle manipulated variable. When the deviation reaches 0 or lower, the manipulated variable is set to the lower limit of the limit cycle manipulated variable. When the deviation becomes greater than the autotuning hysteresis, the manipulated variable is set to the upper limit of the limit cycle manipulated variable again. This process is repeated two and a half times to calculate the optimum PID constants. The upper and lower limits of the limit cycle manipulated variable are calculated from the values of the parameters.

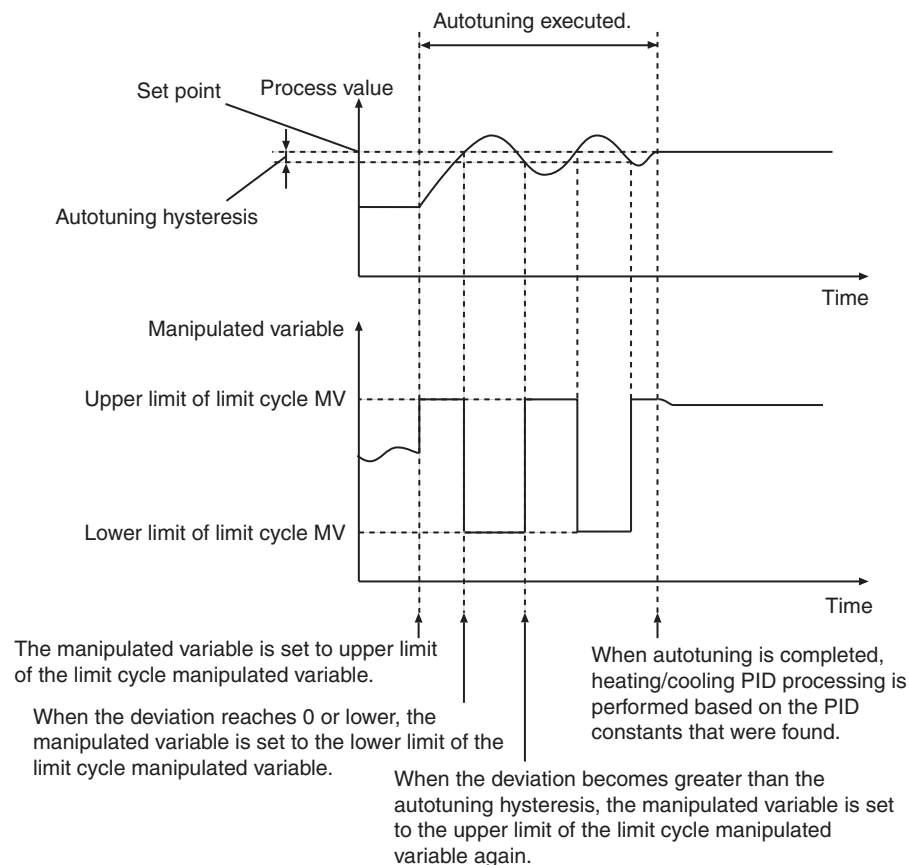

Autotuning is executed during heating/cooling PID control (i.e., when the value of *Run* is TRUE) if the value of *StartAT* changes to TRUE. If *StartAT* is TRUE when *Run* changes to TRUE, autotuning is executed at the start of PID control. When autotuning is completed normally, the calculated PID constants are used immediately. Autotuning is canceled if the value of *StartAT* changes to FALSE during autotuning (i.e., when *ATBusy* is TRUE). If autotuning is canceled, heating/cooling PID control is started again with the previous PID constants.

Execution Timing of Heating/Cooling PID Control

Heating/cooling PID control is repeated periodically. Heating/cooling PID processing is performed when the PIDAT instruction is executed in the user program.

However, if sampling period *SampTime* has not elapsed since the last time heating/cooling PID processing was performed, heating/cooling PID processing is not performed.

If the elapsed time since the last time heating/cooling PID processing was executed exceeds *SampTime*, the excess time (elapsed time – *SampTime*) is carried forward to the next period.

Even if this instruction is not executed as a result of the PrgStop or MC instruction, the elapsed time from the last execution of heating/cooling PID processing is set to 0 at the timing shown by “PID processing executed” in the following figures.

Task period = 60 ms and *SampTime* < 60 ms

The task period is greater than or equal to *SampTime*, so PID processing is executed once every task period.

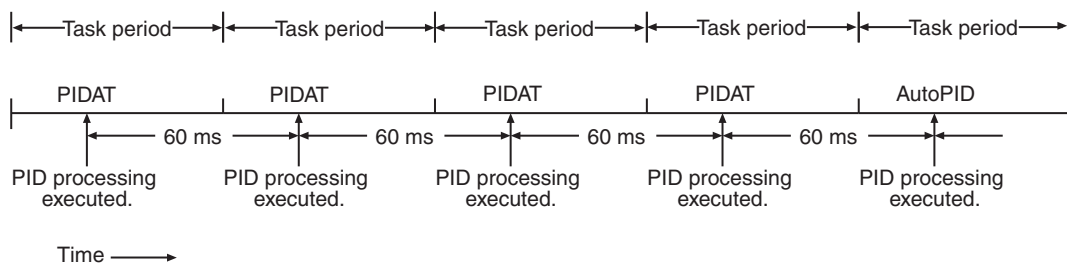

Task period = 60 ms and *SampTime* = 100 ms

The task period is less than *SampTime*, so DIP processing is not executed every period.

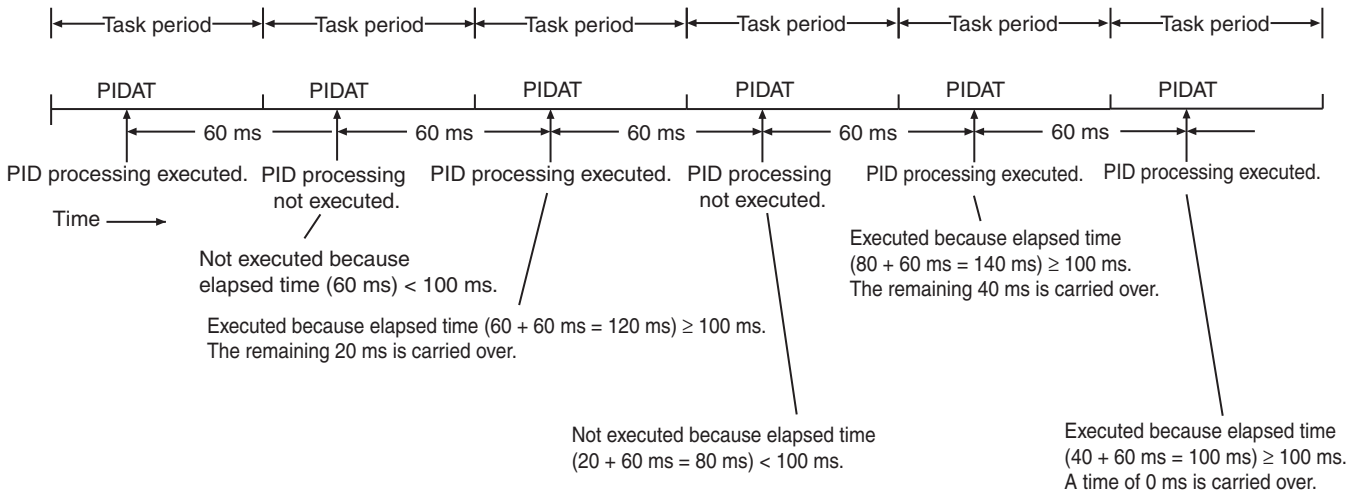

Timing Charts

Timing charts for the instruction variables are provided below for different situations.

● Autotuning Executed during Automatic Operation

- In the following figure, the value of *ManCtl* is FALSE, so the value of *MV* will be *StopMV* as long as the value of *Run* is FALSE.
- When the value of *Run* changes to TRUE, *MV* is output based on the PID constants.
- Autotuning is executed when the value of *StartAT* changes to TRUE. The value of *ATBusy* changes to TRUE.
- When autotuning is completed, the value of *ATBusy* changes to FALSE and the value of *ATDone* changes to TRUE.
- After autotuning is completed, *MV* is output based on the PID constants that were found with autotuning.
- When the value of *Run* changes to FALSE, the value of *MV* changes to *StopMV*. Also, the value of *ATDone* changes to FALSE.

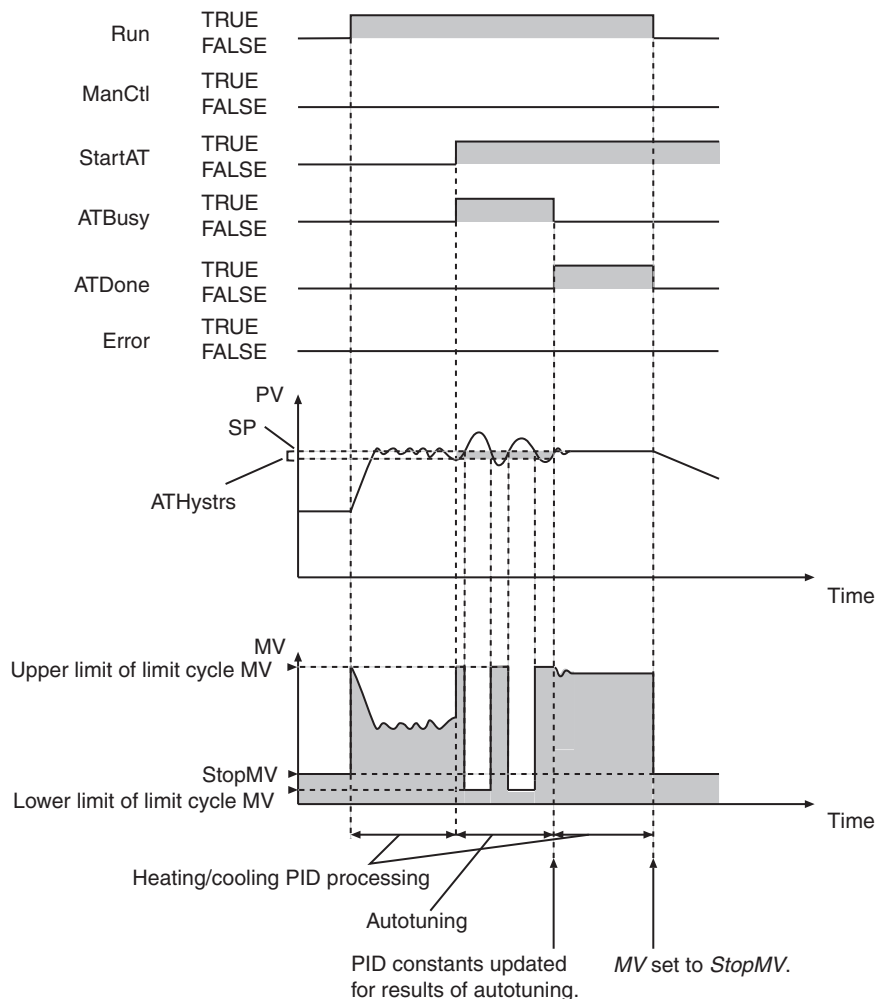

● **Autotuning Executed at the Start of PIDAT Execution**

- In the following figure, the value of *ManCtl* is FALSE, so the value of *MV* will be *StopMV* as long as the value of *Run* is FALSE.
- While the value of *Run* is TRUE, autotuning is not executed even if the value of *StartAT* changes to TRUE.
- Autotuning is executed when the values of both *StartAT* and *Run* change to TRUE. The value of *ATBusy* changes to TRUE.
- When autotuning is completed, the value of *ATBusy* changes to FALSE and the value of *ATDone* changes to TRUE.
- After autotuning is completed, *MV* is output based on the PID constants that were found with autotuning.

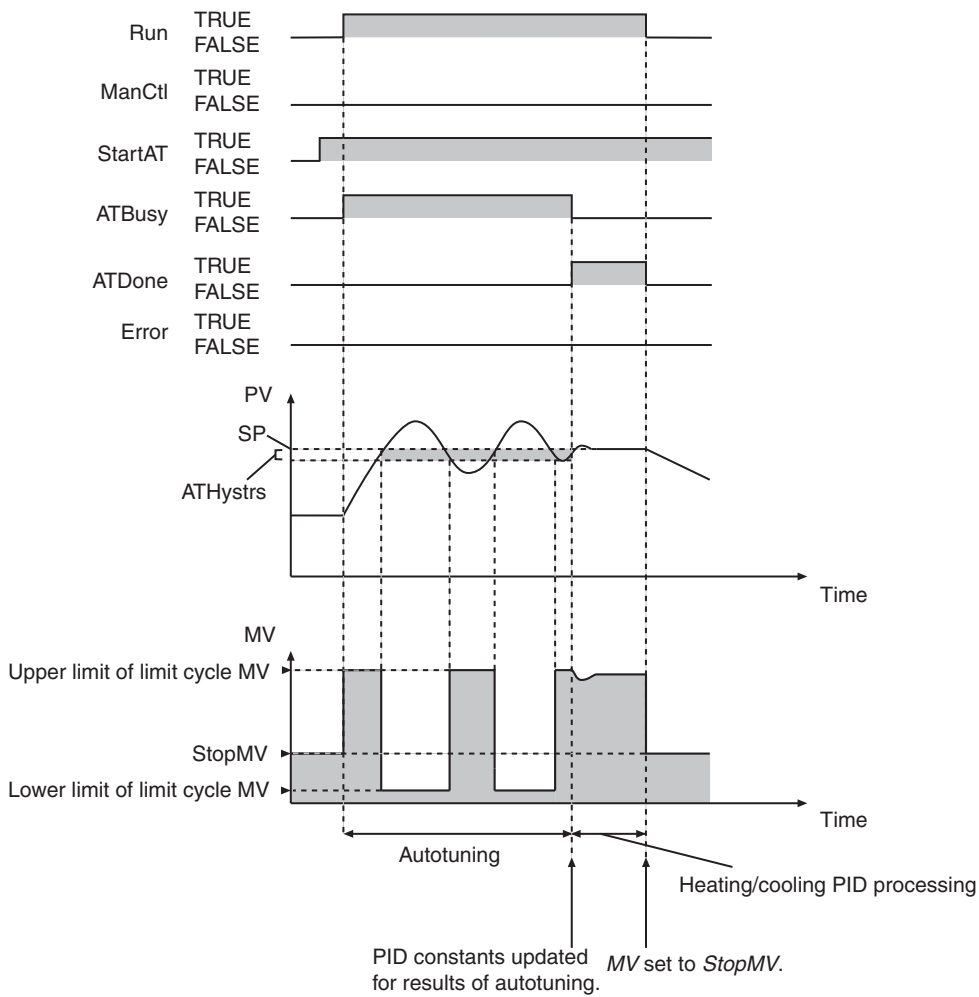

● **Autotuning Canceled**

- In the following figure, the value of *ManCtl* is FALSE, so the value of *MV* will be *StopMV* as long as the value of *Run* is FALSE.
- When the value of *Run* changes to TRUE, *MV* is output based on the PID constants.
- Autotuning is executed when the value of *StartAT* changes to TRUE. The value of *ATBusy* changes to TRUE.
- Autotuning is canceled if the value of *StartAT* changes to FALSE during autotuning. The value of *ATBusy* changes to FALSE.
- After autotuning is completed, *MV* is output based on the PID constants from just before autotuning was started.
- When the value of *Run* changes to FALSE, the value of *MV* changes to *StopMV*.
- The value of *ATDone* does not change to TRUE because autotuning was aborted.

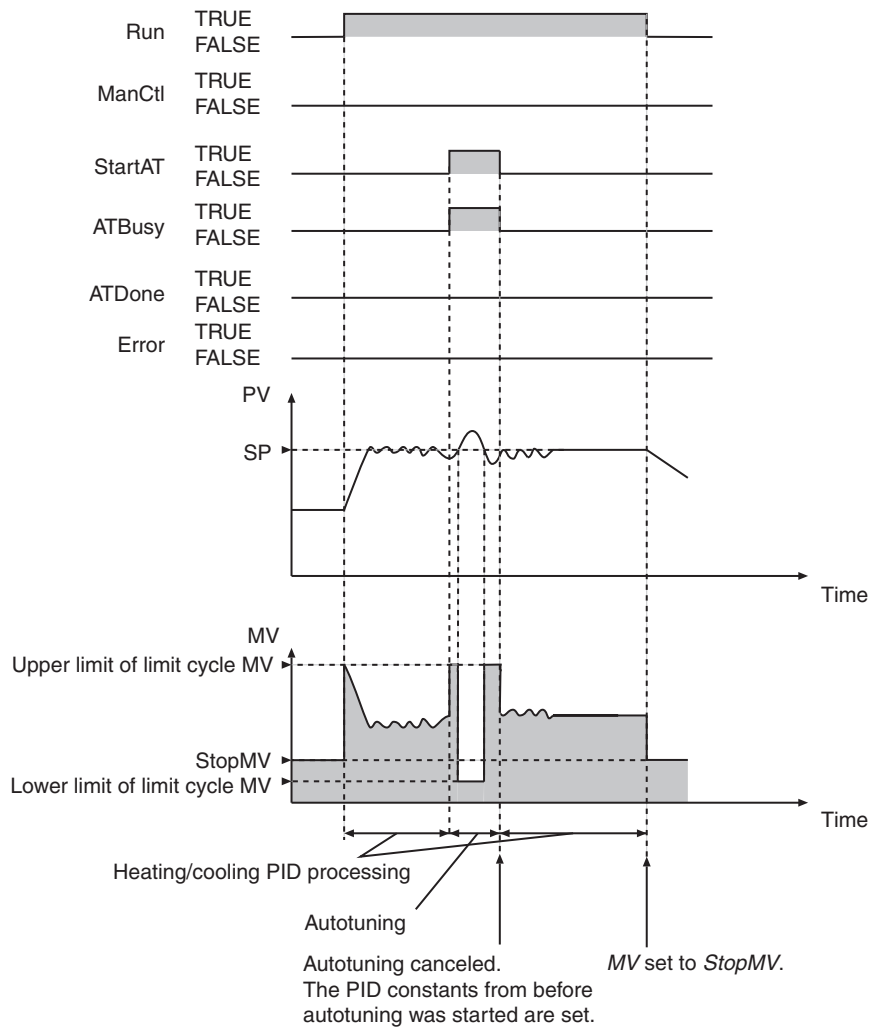

● **An Autotuning Error Occurs during Autotuning**

An autotuning error occurs and autotuning is stopped in the following cases.

- If the manipulated variable equals the upper limit of the limit cycle manipulated variable and the time for the deviation to reach 0 exceeds 19,999 s.
- If the manipulated variable equals the lower limit of the limit cycle manipulated variable and the time for the deviation to reach *ATHysts* or higher exceeds 19,999 s.

The value of *Error* does not change to TRUE even if an error occurs during autotuning. Autotuning is also not recorded in the event log.

If autotuning is canceled, heating/cooling PID control is started again with the previous PID constants.

- In the following figure, the value of *ManCtl* is FALSE, so the value of *MV* will be *StopMV* as long as the value of *Run* is FALSE.
- When the value of *Run* changes to TRUE, *MV* is output based on the PID constants.
- Autotuning is executed when the value of *StartAT* changes to TRUE. The value of *ATBusy* changes to TRUE.
- Autotuning is canceled immediately if an autotuning error occurs during execution of autotuning. The value of *ATBusy* changes to FALSE.
- The value of *Error* does not change to TRUE even if an error occurs during autotuning.
- After autotuning is canceled, *MV* is output based on the PID constants from just before autotuning was started.
- When the value of *Run* changes to FALSE, the value of *MV* changes to *StopMV*.
- The value of *ATDone* does not change to TRUE because autotuning was aborted.

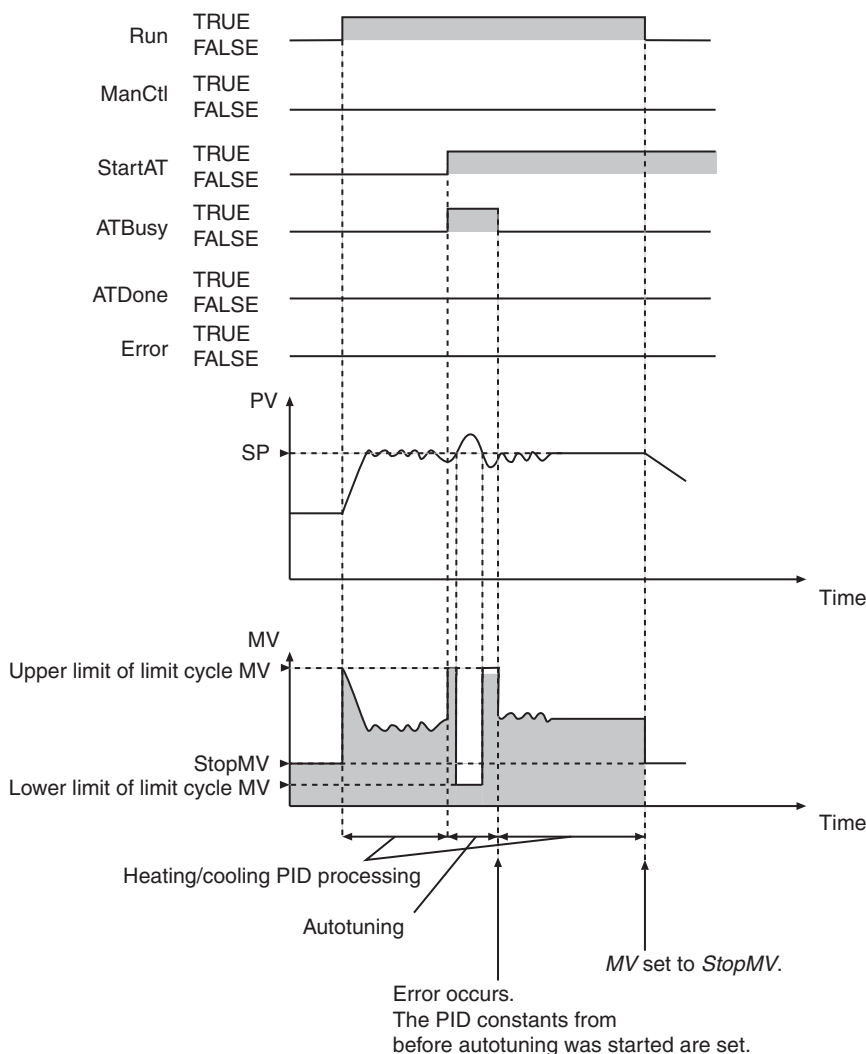

Additional Information

Adjusting PID Constants

Refer to the section on the PIDAT instruction (page 2-666) for the adjustment methods for PID constants.

Initial PID Constants for Temperature Control

If you use the PIDAT instruction for temperature control, use the following initial values of the PID constants as reference. Use the default values for the other variables.

Variables	Initial values (reference values)*1
ProportionalBand_Heat and ProportionalBand_Cool	10%FS
IntegrationTime_Heat and IntegrationTime_Cool	233 s
DerivativeTime_Heat and DerivativeTime_Cool	40 s

*1 If you perform autotuning, use the results from autotuning.

Precautions for Correct Use

- The values of PV and SP must be between the values of *RngLowLmt* and *RngUpLmt*, inclusive. Align the units of these variables as shown below.

Unit	Values of <i>PV</i> and <i>SP</i>	Values of <i>RngLowLmt</i> and <i>RngUpLmt</i>
% FS	$PV = (\text{Process value in physical units} - \text{MIN}) / (\text{MAX} - \text{MIN}) \times 100$ $SP = (\text{Set point in physical units} - \text{MIN}) / (\text{MAX} - \text{MIN}) \times 100^{*1}$	<i>RngLowLmt</i> = 0 <i>RngUpLmt</i> = 100
Physical unit	<i>PV</i> = Process value in physical units <i>SV</i> = Set point in physical units	<i>RngLowLmt</i> = MIN <i>RngUpLmt</i> = MAX*1

*1 MAX: Upper limit of input range in physical units, MIN: Lower limit of input range in physical units,

- The following table shows which variables can be changed depending on the operating status.

Variables	Control status		
	Instruction execution stopped*1	Automatic operation when autotuning is not being executed*2	Automatic operation when autotuning is being executed*3
Run	Possible	Possible	Possible
ManCtl	Possible	Possible	Possible
StartAT	Possible	Possible	Possible
DeadBand	Possible	Possible	Possible
PV	Possible	Possible	Possible
SP	Possible	Possible	Not possible*4
MVLowLmt	Possible	Possible	Not possible*4
MVUpLmt	Possible	Possible	Not possible*4
ManResetVal*5	---	---	---
MVTrackSw	Possible	Possible	Not possible*4
MVTrackVal	Possible	Possible	Not possible*4
StopMV	Possible	Possible	Possible
ErrorMV	Possible	Possible	Possible
Alpha	Possible	Possible	Not possible*4
ATCalcGain	Possible	Possible	Not possible*4
ATHystrs	Possible	Possible	Not possible*4
CtlPrdCool	Possible	Possible	Not possible*4
SampTime	Possible	Not possible*6	Not possible*4
RngLowLmt	Possible	Not possible*6	Not possible*4
RngUpLmt	Possible	Not possible*6	Not possible*4
DirOpr*5	---	---	---
ProportionalBand_Heat	Possible	Possible	Not possible*7
IntegrationTime_Heat	Possible	Possible	Not possible*7
DerivativeTime_Heat	Possible	Possible	Not possible*7
ProportionalBand_Cool	Possible	Possible	Not possible*7
IntegrationTime_Cool	Possible	Possible	Not possible*7
DerivativeTime_Cool	Possible	Possible	Not possible*7
ManMV	Possible	Possible	Possible

*1 *ManCtl* is TRUE, *Run* is FALSE, *Error* is TRUE, or *MVTrackSw* is TRUE.

*2 *ManCtl* is FALSE, *Run* is TRUE, *Error* is FALSE, *MVTrackSw* is FALSE, and *ATBusy* is FALSE.

*3 *ManCtl* is FALSE, *Run* is TRUE, *Error* is FALSE, *MVTrackSw* is FALSE, and *ATBusy* is TRUE.

*4 Autotuning is executed with the value from just before execution of autotuning.

*5 This instruction does not use this variable. You can change the value, but it is ignored.

*6 Operation is performed with the value from just before the execution of the operation.

*7 You can change the value, but it is ignored. When autotuning is completed, the values are overwritten with the values calculated with autotuning.

- *SampTime* is truncated below 100 nanoseconds.
- If the value of *StartAT* changes to TRUE while the value of *ManCtl* is TRUE, autotuning starts the next time the value of *ManCtl* changes to FALSE.
- If the value of *ErrorMV* is not within the valid range (–320 to 320), the value of *MV* will be 0 when an error occurs.
- Autotuning is canceled if the value of *ManCtl* changes to TRUE during autotuning.
- The value of *Error* does not change to TRUE even if an error occurs during autotuning. Autotuning is also not recorded in the event log.
- An error occurs in the following case. *Error* will change to TRUE, and an error code is assigned to *ErrorID*. *ATDone* and *ATBusy* change to FALSE. *MV* is set to the value of *ErrorMV* if the values of *ManCtl* and *Run* are FALSE. If the value of *ErrorMV* is outside of the valid range, the value of *MV* is 0.

Error	Value of <i>ErrorID</i>
The value of an input variable is outside of the valid range.	16#0400
<i>RngLowLmt</i> is greater than or equal to <i>RngUpLmt</i> .	16#0401
<i>MVLowLmt</i> is greater than or equal to <i>MVUpLmt</i> .	

- If an error stop is required for conditions other than the above, program the system so that the value of *Run* changes to FALSE when the error occurs.
- If an error occurs because the value of *PV* or *SP* exceeds the valid range, the error status is maintained for five seconds even if the value returns to within the valid range sooner. That is, the value of *Error* will remain FALSE for five seconds.
- Heating/cooling PID control is restarted automatically if the value of *Run* is TRUE after the error is reset. Autotuning is restarted automatically if the values of *Run* and *StartAT* are TRUE.
- A check is made for errors each sampling period.
- If backup and restore operations are performed under the following conditions, the PID constants that were found with autotuning will revert to the values from before the backup operation. Use it with caution.
 - A Retain attribute is specified for the in-out parameters.
 - The operations are performed in the following order: backup, autotuning, and then restore.
- When you change from automatic operation to manual operation, the value of *MV_Heat* or *MV_Cool*, whichever is positive, is taken on to achieve bumpless operation (i.e., to prevent abrupt changes). Therefore, the value of the other variable may change abruptly.

Version Information

A CPU Unit with unit version 1.08 or later and Sysmac Studio version 1.09 or higher are required to use this instruction.

Sample Programming

In this sample, the PIDAT_HeatCool instruction is used to perform temperature control. There is one analog thermocouple input from the controlled system. There are two outputs to the controlled system, a heating digital output and a cooling digital output. The heating digital output turns the heating device ON and OFF. The cooling digital output opens and closes the solenoid valve for the cooling water.

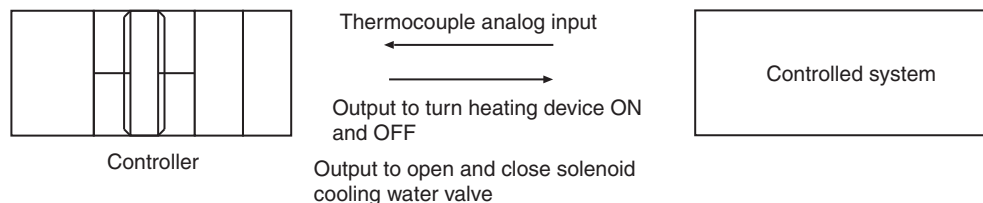

Unit Configuration

The following Units are connected.

- CJ1W-AD04U Isolated-type Universal Input Unit
- CJ1W-OC201 Relay Contact Output Unit

I/O Map

The I/O maps for the Units are set as shown in the following tables.

● C1JW-AD04U

Port	Description	Read/write	Data type	Variable	Variable comment	Variable type
Ch1_AllnPv	Process value for input 1	R	INT	J01_Ch1_AllnPv	Thermocouple input	Global variable

● CJ1W-OC201

Port	Description	Read/write	Data type	Variable	Variable comment	Variable type
Ch1_Out00	Bit 00 of output word 1	RW	BOOL	J02_Ch1_Out00	Output to heating device	Global variable
Ch1_Out04	Bit 04 of output word 1	RW	BOOL	J02_Ch1_Out04	Output to cooling device	Global variable

Touch Panel Specifications

This sample assumes that a touch panel is connected to the Controller. The following I/O information is handled through the touch panel.

I/O	Information
Inputs	Sample programming execution flag Manual/auto control flag Set point Autotuning execution flag Deadband Initial setting parameters Operation setting parameters
I/O	Proportional band, integration time, and derivative time for heating control Proportional band, integration time, and derivative time for cooling control Manual manipulated variable
Outputs	Process value Autotuning normal completion flag Autotuning executing flag Error flag Manipulated variable Manipulated variable for heating control Manipulated variable for cooling control

Converting the Manipulated Variables to Time-proportional Outputs

In this sample, a digital ON/OFF output is used for both the heating device and the cooling device. Therefore, it is necessary to convert the manipulated variables for the heating and cooling devices to time-proportional outputs. The TimeProportionalOut instruction (page 2-729) converts a manipulated variable to a time-proportional output.

However, during autotuning, the outputs to the heating and cooling devices must be changed immediately after the *MV_Heat* and *MV_Cool* outputs from the PIDAT_HeatCool instruction change. Therefore, the TimeProportionalOut instruction cannot be used. If the TimeProportionalOut instruction was used, the outputs to the heating and cooling devices would change only at the control period that was set by the user. In this sample, timer instructions are used to convert the manipulated variables to time-proportional outputs during autotuning.

Application Programming

Definitions of Global Variables

Global Variables

Variable	Data type	Initial value	AT	Retain	Net-work Publish	Comment
J01_Ch1_Al-InPV	INT	0	IOBus://rack#0/slot#0/Ch1_AllnPV		Not published.	Thermocouple input from CJ1W-AD04U
J02_Ch1_Out0	BOOL	FALSE	IOBus://rack#0/slot#1/Ch1_Out/Ch1_Out0		Not published.	Heating output to CJ1W-OC201
J02_Ch1_Out04	BOOL	FALSE	IOBus://rack#0/slot#1/Ch1_Out/Ch1_Out04		Not published.	Cooling output to CJ1W-OC201
PTIn_Run	BOOL	FALSE		✓	Input	Sample programming execution flag input from touch panel
PTIn_ManCtl	BOOL	FALSE		✓	Input	Manual/auto control flag input from touch panel
PTIn_SP	REAL			✓	Input	Set point input from touch panel
PTIn_StartAT	BOOL	FALSE		✓	Input	Autotuning execution flag input from touch panel
PTIn_Dead-Band	REAL	0		✓	Input	Deadband input from touch panel
PTIn_Init-Param	_sIN-IT_SET_PARAMETERS	(SampTime := T#100ms, RngLowLmt := 0.0, RngUpLmt := 100.0, DirOpr := False)		✓	Input	Initial setting parameter input from touch panel
PTIn_InitSetOpr_Samp-Time	LINT	100		✓	Input	Sampling period input from touch panel (unit: ms)
PTIn_Opr-Param	_sOPR_SET_PARAMETERS	(MVLowLmt := -100, MVUpLmt := 100, ManResetVal := 0.0, MVTrackSw := False, MVTrackVal := 0.0, StopMV := 0.0, ErrorMV := 0.0, Alpha := 0.65, ATCalcGain := 1.0, ATHystrs := 0.2)		✓	Input	Operation setting parameter input from touch panel
PTOut_PV	REAL	0			Output	Process value output to touch panel
PT_PB_Heat	REAL	1		✓	Input	Proportional band for heating control I/O from touch panel

Variable	Data type	Initial value	AT	Retain	Net-work Publish	Comment
PT_TI_Heat	LINT	1000		✓	Input	Integration time for heating control I/O from touch panel (unit: ms)
PT_TD_Heat	LINT	1000		✓	Input	Derivative time for heating control I/O from touch panel (unit: ms)
PT_PB_Cool	REAL	1		✓	Input	Proportional band for cooling control I/O from touch panel
PT_TI_Cool	LINT	1000		✓	Input	Integration time for cooling control I/O from touch panel (unit: ms)
PT_TD_Cool	LINT	1000		✓	Input	Derivative time for cooling control I/O from touch panel (unit: ms)
PT_ManMV	REAL	0		✓	Input	Manual manipulated variable I/O from touch panel
PTOut_AT-Done	BOOL	FALSE			Output	Autotuning normal completion flag output to touch panel
PTOut_AT-Busy	BOOL	FALSE			Output	Autotuning executing flag output to touch panel
PTOut_Error	BOOL	FALSE			Output	Error flag output to touch panel
PTOut_MV	REAL	0			Output	Manipulated variable output to touch panel
PTOut_M-VHeat	REAL	0			Output	Manipulated variable for heating control output to touch panel
PTOut_M-VCool	REAL	0			Output	Manipulated variable for cooling control output to touch panel

LD

Internal Variables	Variable	Data type	Initial value	Comment
	PB_Heat	REAL	0	Proportional band for heating control
	PB_Cool	REAL	0	Proportional band for cooling control
	MV	REAL	0	Manipulated variable
	MV_Heat	REAL	0	Manipulated variable for heating control
	MV_Cool	REAL	0	Manipulated variable for cooling control
	PIDAT_HeatCool_inst	PIDAT_HeatCool		Instance of PIDAT_HeatCool instruction
	TI_Heat	TIME	T#0s	Integration time for heating control
	TI_Cool	TIME	T#0s	Integration time for cooling control
	TD_Heat	TIME	T#0s	Derivative time for heating control
	TD_Cool	TIME	T#0s	Derivative time for cooling control
	ManMV	REAL	0	Manual manipulated variable
	CtlPrd_Cool	TIME	T#20s	Cooling control period
	CtlPrd_Heat	TIME	T#2s	Heating control period
	TPOHeat_inst	TimeProportionalOut		Instance of TimeProportionalOut instruction for heating control
	TPOCool_inst	TimeProportionalOut		Instance of TimeProportionalOut instruction for cooling control
	ATHeatPhase	BOOL	FALSE	Autotuning heating control flag
	ATCoolPhase	BOOL	FALSE	Autotuning cooling control flag
	MVHeatTime	TIME	T#0s	Autotuning heating control time
	MVCoolTime	TIME	T#0s	Autotuning cooling control time
	AT_Heat_inst	TP		Instance of TP instruction for heating control manipulated variable output during autotuning
	AT_Cool_inst	TP		Instance of TP instruction for cooling control manipulated variable output during autotuning
	EachCtlPrd_ATHeat_inst	TON		Instance of TON instruction for heating control manipulated variable output during autotuning
	EachCtlPrd_ATCool_inst	TON		Instance of TON instruction for cooling control manipulated variable output during autotuning
	PV	REAL	0	Process value

External Variables	Variable	Data type	Comment
	J01_Ch1_AllInPV	INT	Thermocouple input from CJ1W-AD04U
	J02_Ch1_Out00	BOOL	Heating output to CJ1W-OC201
	J02_Ch1_Out04	BOOL	Cooling output to CJ1W-OC201
	PTIn_Run	BOOL	Sample programming execution flag input from touch panel
	PTIn_ManCtl	BOOL	Manual/auto control flag input from touch panel
	PTIn_SP	REAL	Set point input from touch panel
	PTIn_StartAT	BOOL	Autotuning execution flag input from touch panel
	PTIn_DeadBand	REAL	Deadband input from touch panel
	PTIn_InitParam	_sINIT_SET_PARAMS	Initial setting parameter input from touch panel
	PTIn_InitSetOpr_SampTime	LINT	Sampling period input from touch panel (unit: ms)
	PTIn_OprParam	_sOPR_SET_PARAMS	Operation setting parameter input from touch panel
	PTOut_PV	REAL	Process value output to touch panel
	PT_PB_Heat	REAL	Proportional band for heating control I/O from touch panel
	PT_TI_Heat	LINT	Integration time for heating control I/O from touch panel (unit: ms)
	PT_TD_Heat	LINT	Derivative time for heating control I/O from touch panel (unit: ms)
	PT_PB_Cool	REAL	Proportional band for cooling control I/O from touch panel
	PT_TI_Cool	LINT	Integration time for cooling control I/O from touch panel (unit: ms)
	PT_TD_Cool	LINT	Derivative time for cooling control I/O from touch panel (unit: ms)
	PT_ManMV	REAL	Manual manipulated variable I/O from touch panel
	PTOut_ATDone	BOOL	Autotuning normal completion flag output to touch panel
	PTOut_ATBusy	BOOL	Autotuning executing flag output to touch panel
	PTOut_Error	BOOL	Error flag output to touch panel
	PTOut_MV	REAL	Manipulated variable output to touch panel
	PTOut_MVHeat	REAL	Manipulated variable for heating control output to touch panel
	PTOut_MVCool	REAL	Manipulated variable for cooling control output to touch panel

Convert unit of input values from CJ1W-AD04U and touch panel.

Inline ST

Note: The contents of the inline ST are given below at *Contents of Inline ST1.*

Execute PIDAT_HeatCool instruction.

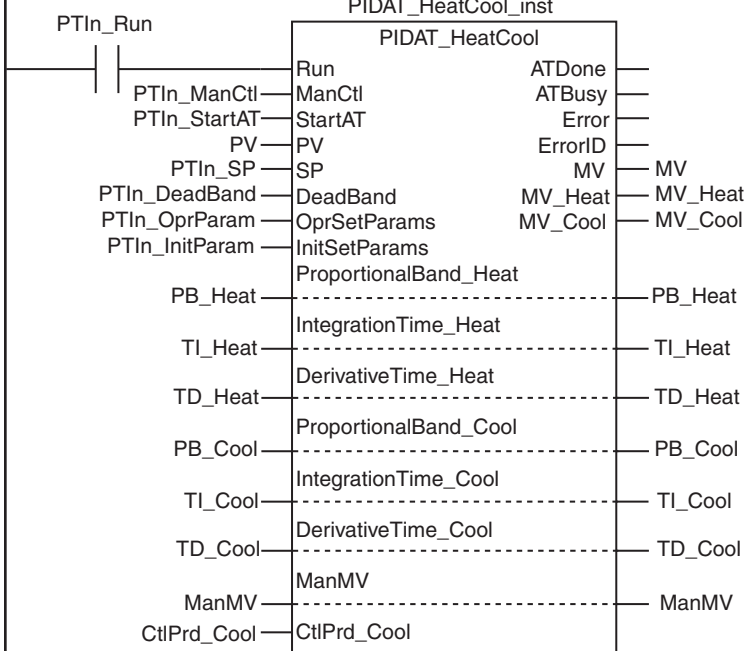

Prepare to convert to time-proportional outputs during execution of autotuning.

PIDAT_HeatCool_inst.ATBusy

Inline ST

Note: The contents of the inline ST are given below at *Contents of Inline ST2.*

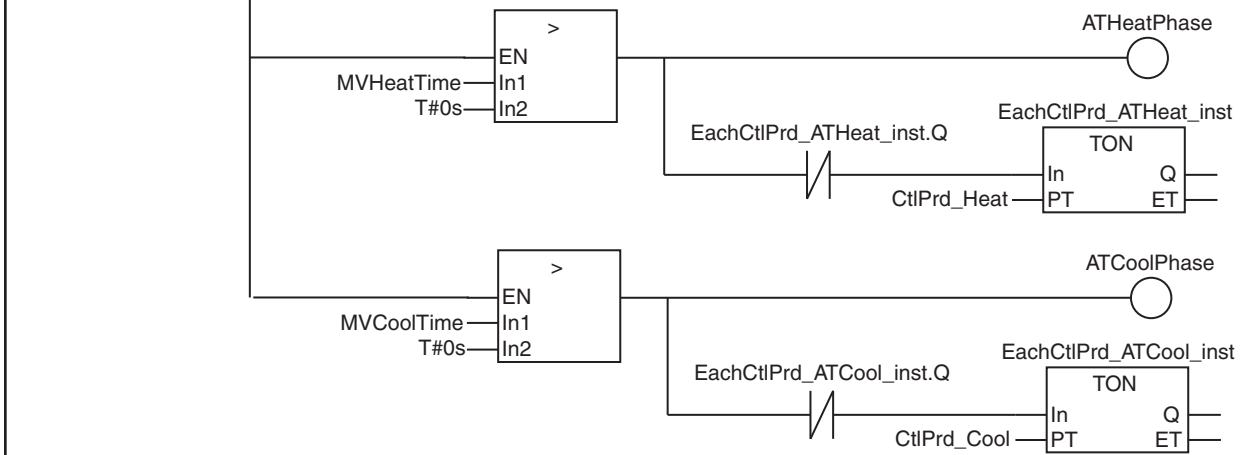

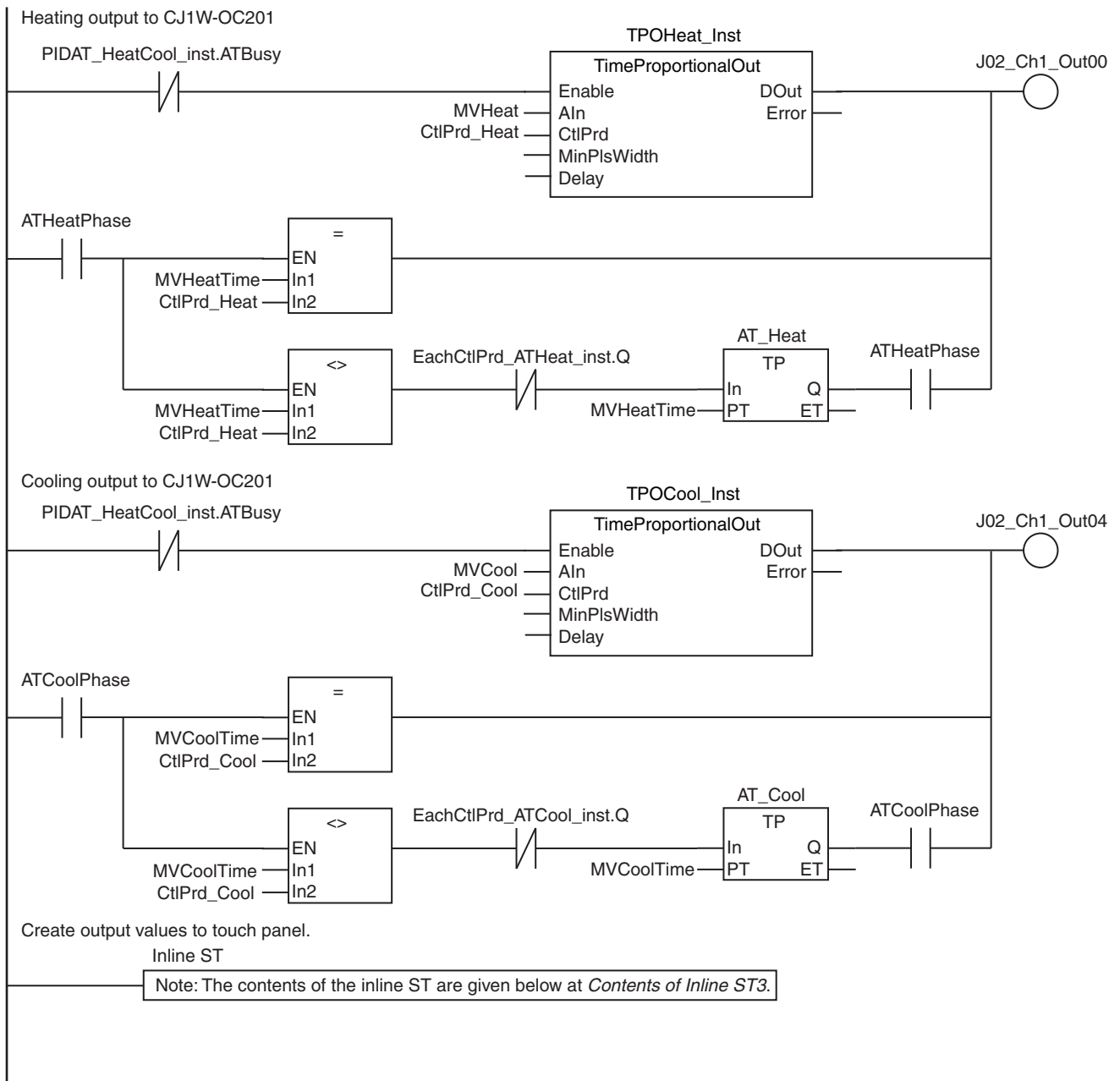

● Contents of Inline ST1

```
// Convert unit of input values from CJ1W-AD04U and touch panel.
PV := INT_TO_REAL(J01_Ch1_AIInPV)/REAL#10.0;

PTIn_InitParam.SampTime := NanoSecToTime(PTIn_InitSetOpr_SampTime*1000000);

PB_Heat := PT_PB_Heat;
TI_Heat := NanoSecToTime(PT_TI_Heat*1000000);
TD_Heat := NanoSecToTime(PT_TD_Heat*1000000);
PB_Cool := PT_PB_Cool;
TI_Cool := NanoSecToTime(PT_TI_Cool*1000000);
TD_Cool := NanoSecToTime(PT_TD_Cool*1000000);

ManMV := PT_ManMV;
```

● Contents of Inline ST2

```
MVHeatTime := MULTIME(CtlPrd_Heat, (MV_Heat/100));  
MVCoolTime := MULTIME(CtlPrd_Cool, (MV_Cool/100));
```

● Contents of Inline ST3

```
// Create output values to touch panel.  
PTOut_PV := PV;  
  
PTOut_ATDone := PIDAT_HeatCool_inst.ATDone;  
PTOut_ATBusy := PIDAT_HeatCool_inst.ATBusy;  
PTOut_Error := PIDAT_HeatCool_inst.Error;  
  
PTOut_MV := PIDAT_HeatCool_inst.MV;  
PTOut_MVHeat := PIDAT_HeatCool_inst.MV_Heat;  
PTOut_MVCool := PIDAT_HeatCool_inst.MV_Cool;  
  
PT_PB_Heat := PB_Heat;  
PT_TI_Heat := TimeToNanoSec( TI_Heat )/1000000;  
PT_TD_Heat := TimeToNanoSec( TD_Heat )/1000000;  
PT_PB_Cool := PB_Cool;  
PT_TI_Cool := TimeToNanoSec( TI_Cool )/1000000;  
PT_TD_Cool := TimeToNanoSec( TD_Cool )/1000000;  
  
PT_ManMV := ManMV;
```

ST

Internal Variables	Variable	Data type	Initial value	Comment
	PB_Heat	REAL	0	Proportional band for heating control
	PB_Cool	REAL	0	Proportional band for cooling control
	MV	REAL	0	Manipulated variable
	MV_Heat	REAL	0	Manipulated variable for heating control
	MV_Cool	REAL	0	Manipulated variable for cooling control
	PIDAT_HeatCool_inst	PIDAT_HeatCool		Instance of PIDAT_HeatCool instruction
	TI_Heat	TIME	T#0s	Integration time for heating control
	TI_Cool	TIME	T#0s	Integration time for cooling control
	TD_Heat	TIME	T#0s	Derivative time for heating control
	TD_Cool	TIME	T#0s	Derivative time for cooling control
	ManMV	REAL	0	Manual manipulated variable
	CtlPrd_Cool	TIME	T#20s	Cooling control period
	CtlPrd_Heat	TIME	T#2s	Heating control period
	TPOHeat_inst	TimeProportionalOut		Instance of TimeProportionalOut instruction for heating control
	TPOCool_inst	TimeProportionalOut		Instance of TimeProportionalOut instruction for cooling control
	ATHeatPhase	BOOL	FALSE	Autotuning heating control flag
	ATCoolPhase	BOOL	FALSE	Autotuning cooling control flag
	MVHeatTime	TIME	T#0s	Autotuning heating control time
	MVCoolTime	TIME	T#0s	Autotuning cooling control time
	AT_Heat_inst	TP		Instance of TP instruction for heating control manipulated variable output during autotuning
	AT_Cool_inst	TP		Instance of TP instruction for cooling control manipulated variable output during autotuning
	EachCtlPrd_ATHeat_inst	TON		Instance of TON instruction for heating control manipulated variable output during autotuning
	EachCtlPrd_ATCool_inst	TON		Instance of TON instruction for cooling control manipulated variable output during autotuning
	PV	REAL	0	Process value

External Variables	Variable	Data type	Comment
	J01_Ch1_AIInPV	INT	Thermocouple input from CJ1W-AD04U
	J02_Ch1_Out00	BOOL	Heating output to CJ1W-OC201
	J02_Ch1_Out04	BOOL	Cooling output to CJ1W-OC201
	PTIn_Run	BOOL	Sample programming execution flag input from touch panel
	PTIn_ManCtl	BOOL	Manual/auto control flag input from touch panel
	PTIn_SP	REAL	Set point input from touch panel
	PTIn_StartAT	BOOL	Autotuning execution flag input from touch panel
	PTIn_DeadBand	REAL	Deadband input from touch panel
	PTIn_InitParam	_sINIT_SET_PARAMS	Initial setting parameter input from touch panel
	PTIn_InitSetOpr_SampTime	LINT	Sampling period input from touch panel (unit: ms)
	PTIn_OprParam	_sOPR_SET_PARAMS	Operation setting parameter input from touch panel
	PTOut_PV	REAL	Process value output to touch panel
	PT_PB_Heat	REAL	Proportional band for heating control I/O from touch panel
	PT_TI_Heat	LINT	Integration time for heating control I/O from touch panel (unit: ms)
	PT_TD_Heat	LINT	Derivative time for heating control I/O from touch panel (unit: ms)
	PT_PB_Cool	REAL	Proportional band for cooling control I/O from touch panel
	PT_TI_Cool	LINT	Integration time for cooling control I/O from touch panel (unit: ms)
	PT_TD_Cool	LINT	Derivative time for cooling control I/O from touch panel (unit: ms)
	PT_ManMV	REAL	Manual manipulated variable I/O from touch panel
	PTOut_ATDone	BOOL	Autotuning normal completion flag output to touch panel
	PTOut_ATBusy	BOOL	Autotuning executing flag output to touch panel
	PTOut_Error	BOOL	Error flag output to touch panel
	PTOut_MV	REAL	Manipulated variable output to touch panel
	PTOut_MVHeat	REAL	Manipulated variable for heating control output to touch panel
	PTOut_MVCool	REAL	Manipulated variable for cooling control output to touch panel

```
// Convert unit of input values from CJ1W-AD04U and touch panel.
```

```
PV := INT_TO_REAL(J01_Ch1_AIInPV)/REAL#10.0;
```

```
PTIn_InitParam.SampTime := NanoSecToTime(PTIn_InitSetOpr_SampTime*1000000);
```

```

PB_Heat := PT_PB_Heat;
TI_Heat := NanoSecToTime(PT_TI_Heat*1000000);
TD_Heat := NanoSecToTime(PT_TD_Heat*1000000);
PB_Cool := PT_PB_Cool;
TI_Cool := NanoSecToTime(PT_TI_Cool*1000000);
TD_Cool := NanoSecToTime(PT_TD_Cool*1000000);

ManMV    := PT_ManMV;

// Execute PIDAT_HeatCool instruction.
PIDAT_HeatCool_inst(Run
                    ManCtl      :=PTIn_Run,
                    StartAT     :=PTIn_ManCtl,
                    PV          :=PTIn_StartAT,
                    SP          :=PTIn_PV,
                    DeadBand    :=PTIn_SP,
                    OprSetParams:=PTIn_DeadBand,
                    InitSetParams:=PTIn_OprParam,
                    ProportionalBand_Heat :=PB_Heat,
                    IntegrationTime_Heat :=TI_Heat,
                    DerivativeTime_Heat :=TD_Heat,
                    ProportionalBand_Cool :=PB_Cool,
                    IntegrationTime_Cool :=TI_Cool,
                    DerivativeTime_Cool :=TD_Cool,
                    ManMV      :=ManMV,
                    CtlPrd_Cool :=CtlPrd_Cool,
                    MV         =>MV,
                    MV_Heat    =>MV_Heat,
                    MV_Cool    =>MV_Cool);

// Prepare to convert to time-proportional outputs during execution
// of autotuning.
IF PIDAT_HeatCool_inst.ATBusy THEN
    MVHeatTime := MULTIME(CtlPrd_Heat, (MV_Heat/100) );
    MVCoolTime := MULTIME(CtlPrd_Cool, (MV_Cool/100) );
END_IF;

ATHeatPhase := PIDAT_HeatCool_inst.ATBusy & (MVHeatTime>T#0s);
EachCtlPrd_ATHeat_inst(In:= ATHeatPhase & NOT(EachCtlPrd_ATHeat_inst.Q),
                      PT:= CtlPrd_Heat);

ATCoolPhase := PIDAT_HeatCool_inst.ATBusy & (MVCoolTime>T#0s);
EachCtlPrd_ATCool_inst(In:= ATCoolPhase & NOT(EachCtlPrd_ATCool_inst.Q),
                      PT:= CtlPrd_Cool);

// Heating output to CJ1W-OC201
TPOHeat_inst(Enable :=NOT(PIDAT_HeatCool_inst.ATBusy),
             AIn     :=MV_Heat,
             CtlPrd :=CtlPrd_Heat );
AT_Heat_inst(In:= ATHeatPhase & (MVHeatTime<>CtlPrd_Heat) &
             NOT(EachCtlPrd_ATHeat_inst.Q) ,
             PT:= MVHeatTime);
J02_Ch1_Out00 :=( TPOHeat_inst.DOut ) OR
                ( ATHeatPhase & (MVHeatTime=CtlPrd_Heat)) OR
                ( AT_Heat_inst.Q & ATHeatPhase );

// Cooling output to CJ1W-OC201
TPOCool_inst(Enable :=NOT(PIDAT_HeatCool_inst.ATBusy),
             AIn     :=MV_Cool,
             CtlPrd :=CtlPrd_Cool );
AT_Cool_inst(In:= ATCoolPhase & (MVCoolTime<>CtlPrd_Cool) &
             NOT(EachCtlPrd_ATCool_inst.Q) ,
             PT:= MVCoolTime);
J02_Ch1_Out04 :=( TPOCool_inst.DOut ) OR
                ( ATCoolPhase & (MVCoolTime=CtlPrd_Cool)) OR

```

```
( AT_Cool_inst.Q & ATCoolPhase );

// Create output values to touch panel.
PTOut_PV := PV;

PTOut_ATDone := PIDAT_HeatCool_inst.ATDone;
PTOut_ATBusy := PIDAT_HeatCool_inst.ATBusy;
PTOut_Error  := PIDAT_HeatCool_inst.Error;

PTOut_MV      := PIDAT_HeatCool_inst.MV;
PTOut_MVHeat  := PIDAT_HeatCool_inst.MV_Heat;
PTOut_MVCool  := PIDAT_HeatCool_inst.MV_Cool;

PT_PB_Heat := PB_Heat;
PT_TI_Heat := TimeToNanoSec(TI_Heat)/1000000;
PT_TD_Heat := TimeToNanoSec(TD_Heat)/1000000;
PT_PB_Cool := PB_Cool;
PT_TI_Cool := TimeToNanoSec(TI_Cool)/1000000;
PT_TD_Cool := TimeToNanoSec(TD_Cool)/1000000;

PT_ManMV := ManMV;
```

TimeProportionalOut

The TimeProportionalOut instruction converts a manipulated variable to a time-proportional output.

Instruction	Name	FB/ FUN	Graphic expression	ST expression
TimeProportionalOut	Time-proportional Output	FB		TimeProportionalOut_instance(Enable, Aln, CtlPrd, MinPlsWidth, Delay, DOut, Error);

Variables

Name	Meaning	I/O	Description	Valid range	Unit	Default
Enable	Enable	Input	TRUE: Execute FALSE: Reset time-proportional output	Depends on data type.	---	FALSE
Aln	Manipulated variable		Manipulated variable	0 to 100	%	0
CtlPrd	Control period		Control period of time-proportional output	T#0.1s to T#100s	s	T#2s
MinPlsWidth	Minimum pulse width		Minimum pulse width	0 to 50	%	1
Delay	Delay		ON-delay time	0 to 100	%	0
DOut	Time-proportional output	Output	TRUE: Time-proportional output is ON. FALSE: Time-proportional output is OFF.	Depends on data type.	---	---

	Boolean	Bit strings					Integers							Real numbers		Times, durations, dates, and text strings				
	BOOL	BYTE	WORD	DWORD	LWORD	USINT	UINT	UDINT	ULINT	SINT	INT	DINT	LINT	REAL	LREAL	TIME	DATE	TOD	DT	STRING
Enable	OK																			
Aln														OK						
CtlPrd																OK				
MinPlsWidth														OK						
Delay														OK						
DOut	OK																			

Function

The TimeProportionalOut instruction converts a manipulated variable, such as the one for PID control, to a time-proportional output. A time-proportional output converts a manipulated variable to a time ratio between ON and OFF.

While *Enable* is TRUE, the value of manipulated variable *AIn* is converted to time-proportional output *DOut* for control period *CtlPrd*. If *Enable* changes to FALSE, the time-proportional output is reset. *DOut* and *Error* change to FALSE. The values of *CtlPrd*, *MinPlsWidth*, and *Delay* are updated when *Enable* changes from FALSE to TRUE.

The following example is for when the value of *CtlPrd* is 10 s and the value of *AIn* is 20%. While *Enable* is TRUE, *DOut* is TRUE for two seconds and then FALSE for eight seconds. This is repeated at a 10-second period.

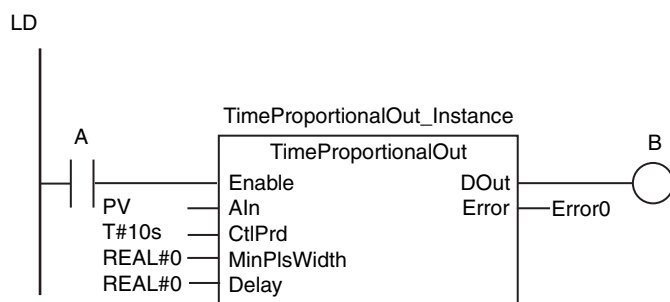

ST

```
TimeProportionalOut_instance(A,PV,T#10s,REAL#0,REAL#0,B,Error0);
```

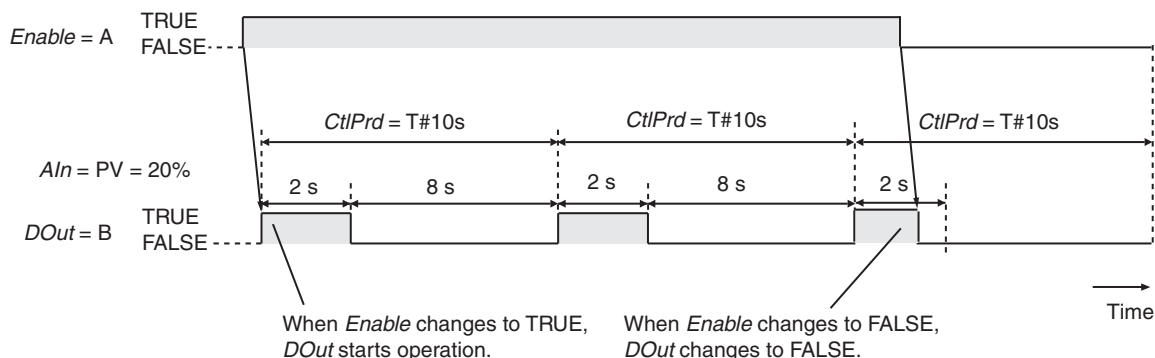

Resolution of Time-proportional Output *DOut*

The minimum unit for the conversion of the value of *AIn* to *DOut* is the resolution of *DOut*.

If the resolution of the value of *AIn* is higher than the resolution of *DOut*, *AIn* is rounded to the resolution of *DOut* when it is converted to *DOut*.

The resolution of *DOut* is given by the following formula.

$$\text{Resolution of } DOut (\%) = \text{Task period} \div \text{CtlPrd} \times 100$$

For example, if the task period is 1 ms and the value of *CtlPrd* is 1 s, the resolution of *DOut* is 0.1%. In this case, the digits after the first decimal digit of the value of *AIn* are truncated.

Update Timing of the Value of Manipulated Variable *AIn*

When value of *AIn* is updated depends on whether *DOut* is FALSE or TRUE.

● *DOut* = FALSE

While *DOut* is FALSE, any change in the value of *AIn* is applied in the next control period.

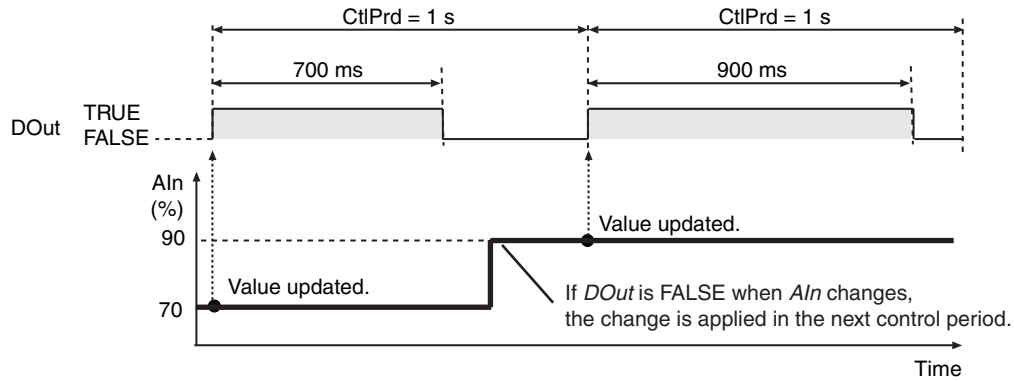

● *DOut* = TRUE

While *DOut* is TRUE, any change in the value of *AIn* is applied immediately.

For example, the following figure shows the operation when the value of control period *CtlPrd* is 1 s.

- If the value of *AIn* is 60% at the start of the control period and it changes to 50% while *DOut* is TRUE, *DOut* is TRUE for only 500 ms.
- Assume that the value of *AIn* was 90% at the start of the control period, that *DOut* changes to TRUE, and that 300 ms later *AIn* changes to 10%. In this case, 100 ms, which is 10%, has already elapsed, so *DOut* changes to FALSE immediately.

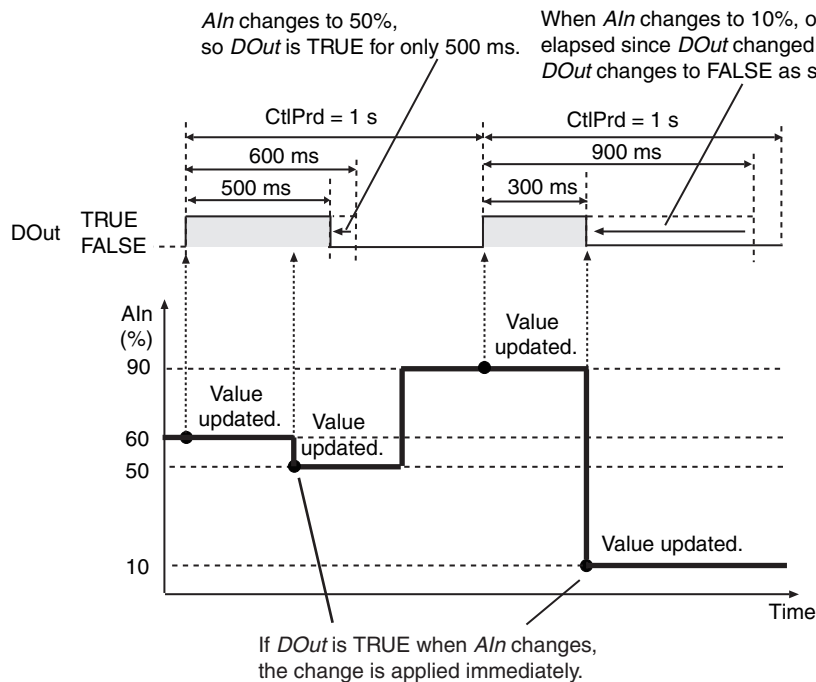

Operation of Time-proportional Output *DOut* for Minimum Pulse Width *MinPlsWidth*

The minimum pulse width is the minimum time that *DOut* will retain a value of TRUE or FALSE. You can set minimum pulse width *MinPlsWidth* to reduce chattering in *DOut*. For example, if the number of times a fan is turned ON and OFF is reduced in cooling control, power consumption is reduced.

The following table shows the operation of *DOut* for the relationship between the values of *MinPlsWidth* and *AIn*.

Relationship between the values of <i>MinPlsWidth</i> and <i>AIn</i>	Operation of <i>DOut</i>
$AIn < MinPlsWidth$	Always FALSE
$MinPlsWidth \leq AIn \leq 100 - MinPlsWidth$	Time-proportional output
$AIn > 100 - MinPlsWidth$	Always TRUE

For example, the following figure shows the operation of *DOut* when *MinPlsWidth* is 30%. If the value of *AIn* is greater than 70%, *DOut* is always TRUE. When *AIn* decreases to 70% or lower, *DOut* operates for the time-proportional output.

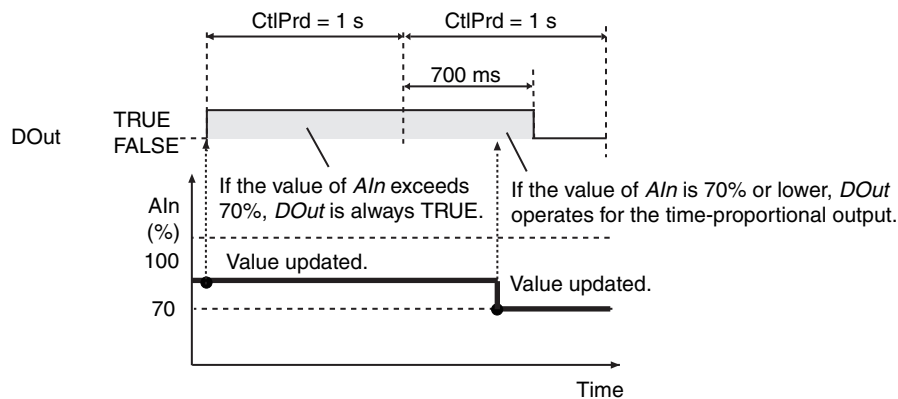

If the value of *AIn* is less than 30%, *DOut* is always FALSE. When *AIn* increases to 30% or higher, *DOut* operates for the time-proportional output.

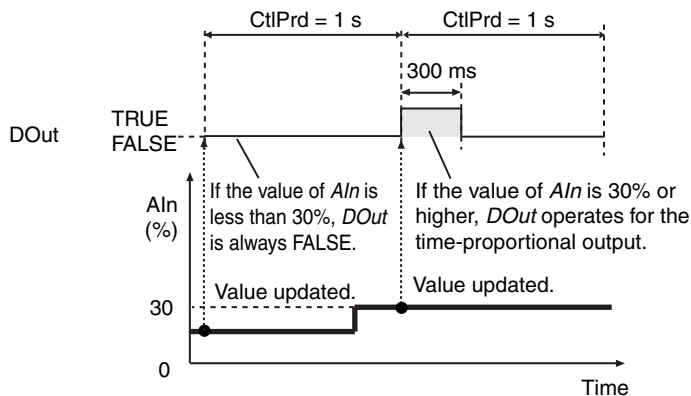

Operation of Time-proportional Output *DOut* for *Delay*

The delay prevents *DOut* from changing to TRUE until the set time has elapsed from the start of the control period. If more than one of this instruction is used, you can offset the timing of when *DOut* changes to TRUE by setting *Delay*. This reduces the chance that *DOut* will turn ON simultaneously for more than one instruction. For example, if you operate more than one heating device, you can use *Delay* to offset when the output to each heating device turns ON to reduce the power that is used at any one time.

DOut changes to TRUE after the percentage of time specified with *Delay* elapses from the start of the control period.

For example, you could set the following values for devices A and B, which have the same control period.

Device	Value of <i>Delay</i>	Value of <i>AI_n</i>	Value of <i>CtlPrd</i>
Device A	0%	20%	10 s
Device B	30%		

DOut for device A changes to TRUE at the start of the control period. *DOut* for device B changes to TRUE three seconds after the start of the control period.

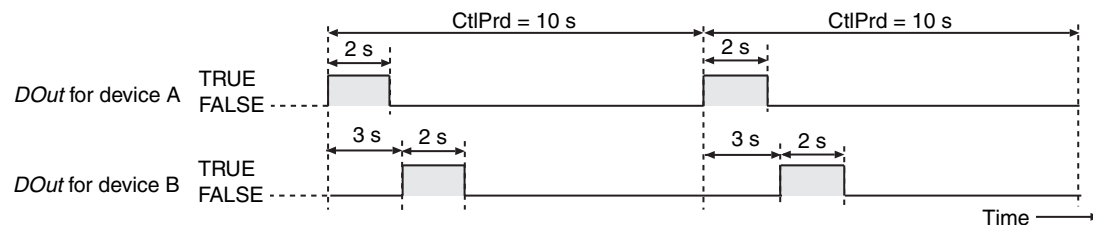

Precautions for Correct Use

- Set the value of control period *CtlPrd* to a multiple of the task period of the task to which the program is assigned. If the task period is not set to a multiple of *CtlPrd*, the actual control period will be from when control period *CtlPrd* ends until the next time the task is executed. For example, if the task period is set to 3 ms and the value of *CtlPrd* is 1 s, the actual control period will be 1,002 ms (from when *CtlPrd* ends until the next time the task is executed).

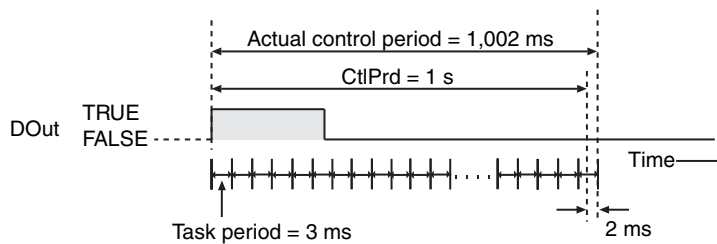

- Set the task period and control period *CtlPrd* so that the resolution of *DOut* is 0.1% or less. If the resolution of *DOut* exceeds 0.1%, the error between the ratio when *DOut* is TRUE and the value of *AI_n* will be excessive and control performance will decrease. For example, if *CtlPrd* is 10 s, set the task period to 10 ms or lower.
- If you use more than one of this instruction and need to synchronize the control periods, use the instructions in the same program. If you use them in different programs, the control periods will depend on the timing of the execution of the programs, and they will not be synchronized.
- The time from when the value of *Enable* changes to TRUE and operation starts for *DOut* is not constant.

- An error occurs if the value of *Aln*, *CtlPrd*, *MinPlsWidth*, or *Delay* is outside of the valid range. *Error* changes to TRUE and *DOut* changes to FALSE. If the value of *Aln* exceeds the valid range, the operation of *DOut* will be as shown below depending on when the error is reset.
- If the error is reset after the point where *DOut* changes to TRUE, the time-proportional output for *DOut* is restarted from the next control period.

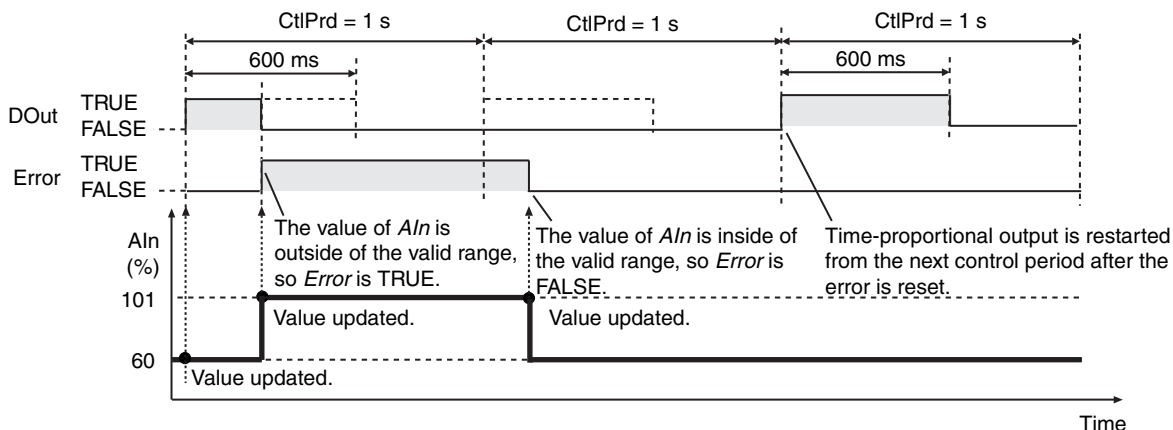

- If the error is reset before the point where *DOut* changes to TRUE, the time-proportional output for *DOut* is restarted in the control period in which the error was reset.

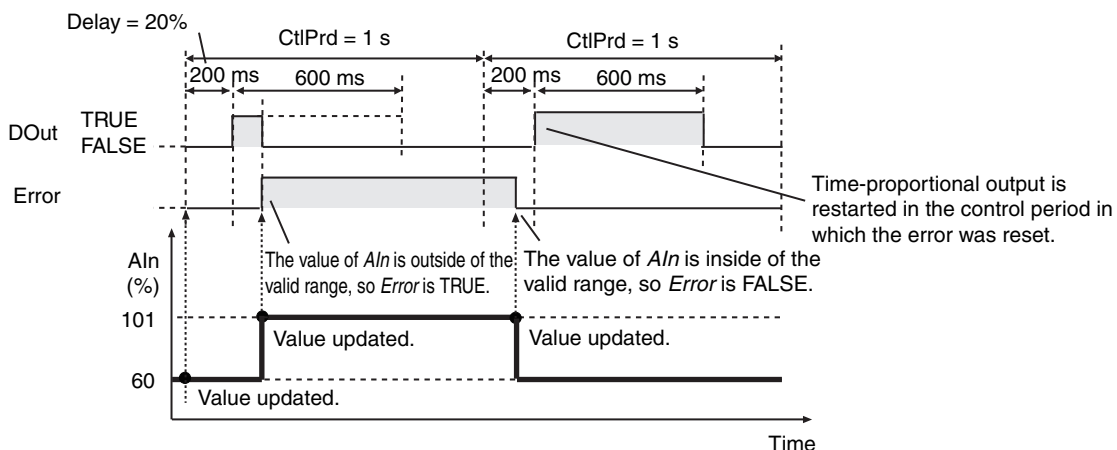

Version Information

A CPU Unit with unit version 1.02 or later and Sysmac Studio version 1.03 or higher are required to use this instruction.

Sample Programming

This sample performs temperature control for four points with upper/lower limit alarms and upper/lower deviation alarms. PID control is performed. The manipulated variables of PID control are converted to time-proportional output values that are output to heating devices.



Specifications

Temperature control is performed according to the following specifications.

Item	Specification
Input Unit	CJ1W-PH41U Isolated-type Universal Input Unit
Input types	K thermocouples
Output Unit	CJ1W-OD212 Transistor Output Unit
Set point	100°C
Upper limit of temperature	200°C
Lower limit of temperature	0°C
Hysteresis of upper/lower limit alarm	5°C
Upper deviation temperature	50°C
Lower deviation temperature	50°C
Hysteresis of upper/lower deviation alarm	3°C
Sampling period for PID control	100 ms
Output control period	1 s

Configuration and Settings

The following settings are used for the CJ1W-PH41U Input Unit.

Item	Set value
Input1:Input signal type	K(1)
Input2:Input signal type	K(1)
Input3:Input signal type	K(1)
Input4:Input signal type	K(1)

The following I/O map settings are used.

Unit	I/O port	Description	Variable
CJ1W-PH41U	Ch1_AllnPv	Process value for input 1 (INT data)	AI1
	Ch2_AllnPv	Process value for input 2 (INT data)	AI2
	Ch3_AllnPv	Process value for input 3 (INT data)	AI3
	Ch4_AllnPv	Process value for input 4 (INT data)	AI4
CJ1W-OD212	Ch1_Out00	Bit 00 of output word 1	DO1
	Ch1_Out01	Bit 01 of output word 1	DO2
	Ch1_Out02	Bit 02 of output word 1	DO3
	Ch1_Out03	Bit 03 of output word 1	DO4

The inputs and outputs for the temperature control for the four points correspond as shown below.

Input	Output
AI1	DO1
AI2	DO2
AI3	DO3
AI4	DO4

The task period of the task to which the program is assigned is 1 ms.

● Configuration Diagram

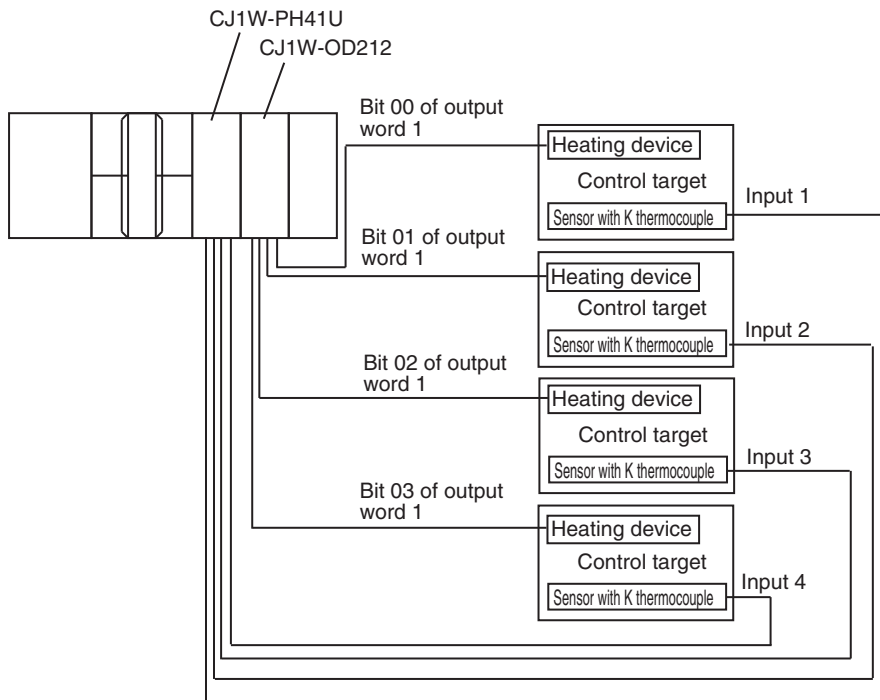

Processing

Perform the following procedure for all four points.

- 1** Get the process temperature.
- 2** Use the LimitAlarm_REAL instruction to output upper/lower limit alarms for the process temperature.
- 3** Perform an output as a safety measure if an error occurs in the LimitAlarm_REAL instruction or if an upper/lower limit alarm occurs.
- 4** Use the LimitAlarmDv_REAL instruction to output upper/lower deviation alarms for the deviation between the set point and the process temperature.
- 5** Perform an output as a safety measure if an error occurs in the LimitAlarmDv_REAL instruction or if an upper/lower deviation alarm occurs.
- 6** Perform temperature control with the PIDAT instruction.
- 7** Use the TimeProportionalOut instruction to output the manipulated variable as a time-proportional value to the heating device.

● Operation of Upper/Lower Limit Alarms and Upper/Lower Deviation Alarms

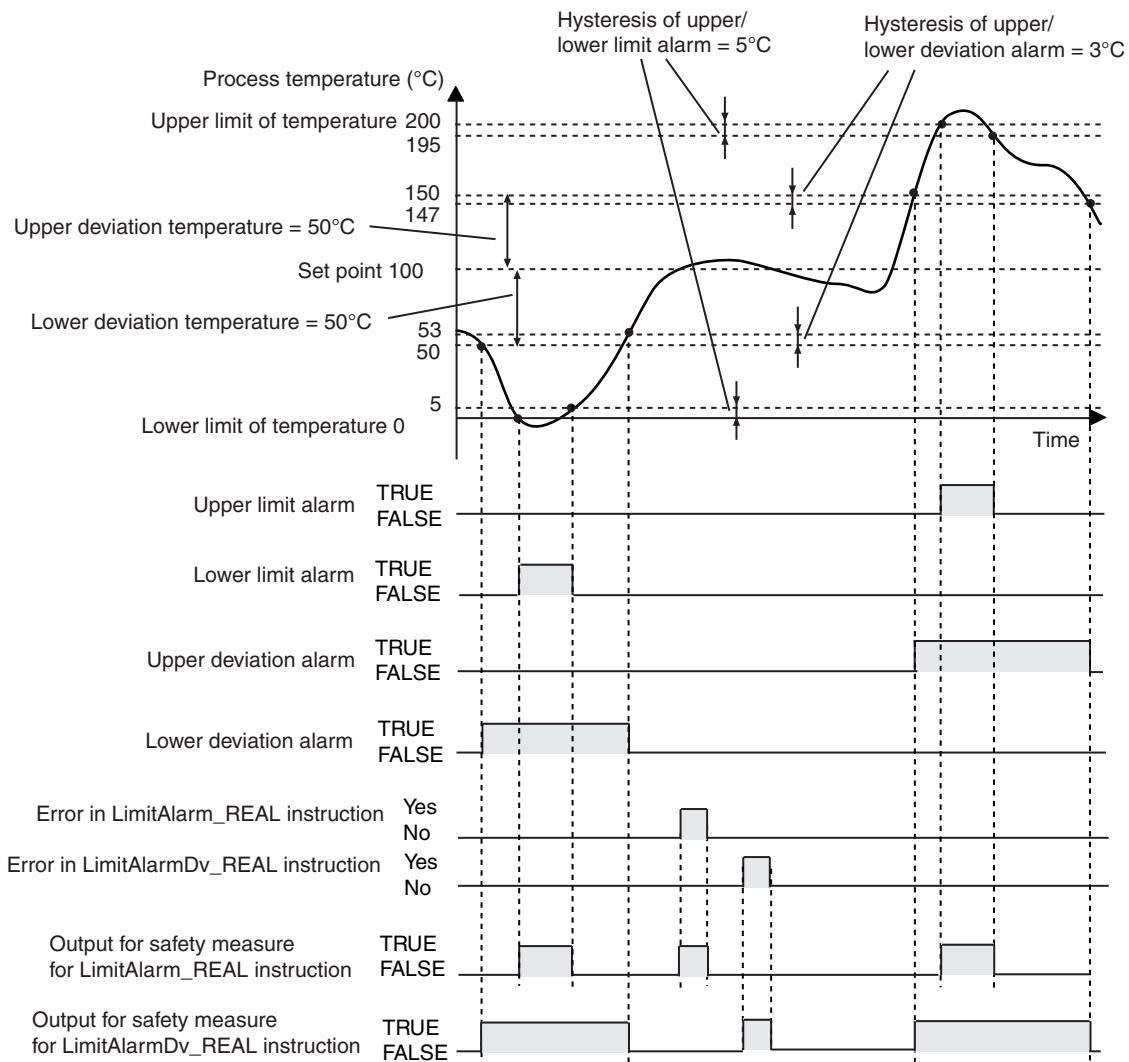

Application Programming

LD

Name	Data type	Default	Retain	Comment
index	UINT	0		Loop index
LimitAlarm_ON	BOOL	True		Execution of Upper/Lower Limit Alarm instruction
LimitAlarmDv_ON	BOOL	True		Execution of Upper/Lower Deviation Alarm instruction
TimeProportionalOut_ON	BOOL	True		Execution of Time-proportional Output instruction
AI	INT	0		Present value
PV	ARRAY[0..3] OF REAL	[4(0.0)]		Process value
SP	ARRAY[0..3] OF REAL	[4(100)]		Set point
DOut_TPO	BOOL	False		Time-proportional output
HighVal	ARRAY[0..3] OF REAL	[4(200)]		Upper limit set value of upper/lower limit alarm

2 Instruction Descriptions

Name	Data type	Default	Retain	Comment
LowVal	ARRAY[0..3] OF REAL	[4(0.0)]		Lower limit set value of upper/lower limit alarm
Hysters_LimitAlarm	ARRAY[0..3] OF REAL	[4(5)]		Hysteresis of upper/lower limit alarm
Q_LimitAlarm	ARRAY[0..3] OF BOOL	[4(False)]		Upper/lower limit alarm output
HighAlm	ARRAY[0..3] OF BOOL	[4(False)]		Upper limit alarm
LowAlm	ARRAY[0..3] OF BOOL	[4(False)]		Lower limit alarm
Error_LimitAlarm	ARRAY[0..3] OF BOOL	[4(False)]		Error in LimitAlarm_ - REAL instruction
Alm_LimitAlarm	ARRAY[0..3] OF BOOL	[4(False)]		Output for safety measure for Upper/Lower Limit Alarm instruction
DvHighVal	ARRAY[0..3] OF REAL	[4(50)]		Upper deviation set value of upper/lower deviation alarm
DvLowVal	ARRAY[0..3] OF REAL	[4(50)]		Lower deviation set value of upper/lower deviation alarm
Q_LimitAlarmDv	ARRAY[0..3] OF BOOL	[4(False)]		Upper/lower deviation alarm output
HighAlmDv	ARRAY[0..3] OF BOOL	[4(False)]		Upper deviation alarm
LowAlmDv	ARRAY[0..3] OF BOOL	[4(False)]		Lower deviation alarm
Error_LimitAlarmDv	ARRAY[0..3] OF BOOL	[4(False)]		Error in LimitAlarmDv_ - REAL instruction
Hysters_LimitAlarmDv	ARRAY[0..3] OF REAL	[4(3)]		Hysteresis of upper/lower deviation alarm
Alm_LimitAlarmDv	ARRAY[0..3] OF BOOL	[4(False)]		Output for safety measure for Upper/Lower Deviation Alarm instruction
Run	ARRAY[0..3] OF BOOL	[4(False)]		Execution condition
ManCtl	ARRAY[0..3] OF BOOL	[4(False)]		Manual/auto control
StartAT	ARRAY[0..3] OF BOOL	[4(False)]		Autotuning execution condition
OprSetParams	_sOPR_SET_PARAMS	(MVLowLmt:=0.0, MVUpLmt:=100.0, ManResetVal:=0.0, MVTrackSw:=False, MVTrackVal:=0.0, StopMV:=0.0, ErrorMV:=0.0, Alpha:=0.65, ATCalcGain:=1.0, ATHysters:=0.2)		Operation setting parameters
InitSetParams	_sINIT_SET_PARAMS	(SampTime:=T#100ms, RngLowLmt:=-10.0, RngUpLmt:=1000.0, DirOpr:=False)		Initial setting parameters
PB	ARRAY[0..3] OF REAL	[4(10)]	✓	Proportional band
TI	ARRAY[0..3] OF TIME	[4(T#0S)]	✓	Integration time
TD	ARRAY[0..3] OF TIME	[4(T#0S)]	✓	Derivative time
ManMV	ARRAY[0..3] OF REAL	[4(0.0)]		Manual manipulated variable
ATDone	ARRAY[0..3] OF BOOL	[4(False)]		Autotuning normal completion
ATBusy	ARRAY[0..3] OF BOOL	[4(False)]		Autotuning busy
Error_PIDAT	ARRAY[0..3] OF BOOL	[4(False)]		Error in PIDAT instruction
ErrorID	ARRAY[0..3] OF WORD	[4(16#0)]		Error ID for PIDAT instruction

Name	Data type	Default	Retain	Comment
MV	ARRAY[0..3] OF REAL	[4(0.0)]		Manipulated variable
CtlPrd	ARRAY[0..3] OF TIME	[4(T#1s)]		Control period
MinPlsWidth	ARRAY[0..3] OF REAL	[4(0.0)]		Minimum pulse width
Delay	ARRAY[0..3] OF REAL	[4(0.0)]		ON-delay time
Error_TimeProportionalOut	ARRAY[0..3] OF BOOL	[4(False)]		Error in TimeProportionalOut instruction
LimitAlarm_REAL_instance	LimitAlarm_REAL			
LimitAlarmDv_REAL_instance	LimitAlarmDv_REAL			
PIDAT_instance	PIDAT			
TimeProportionalOut_instance	TimeProportionalOut			

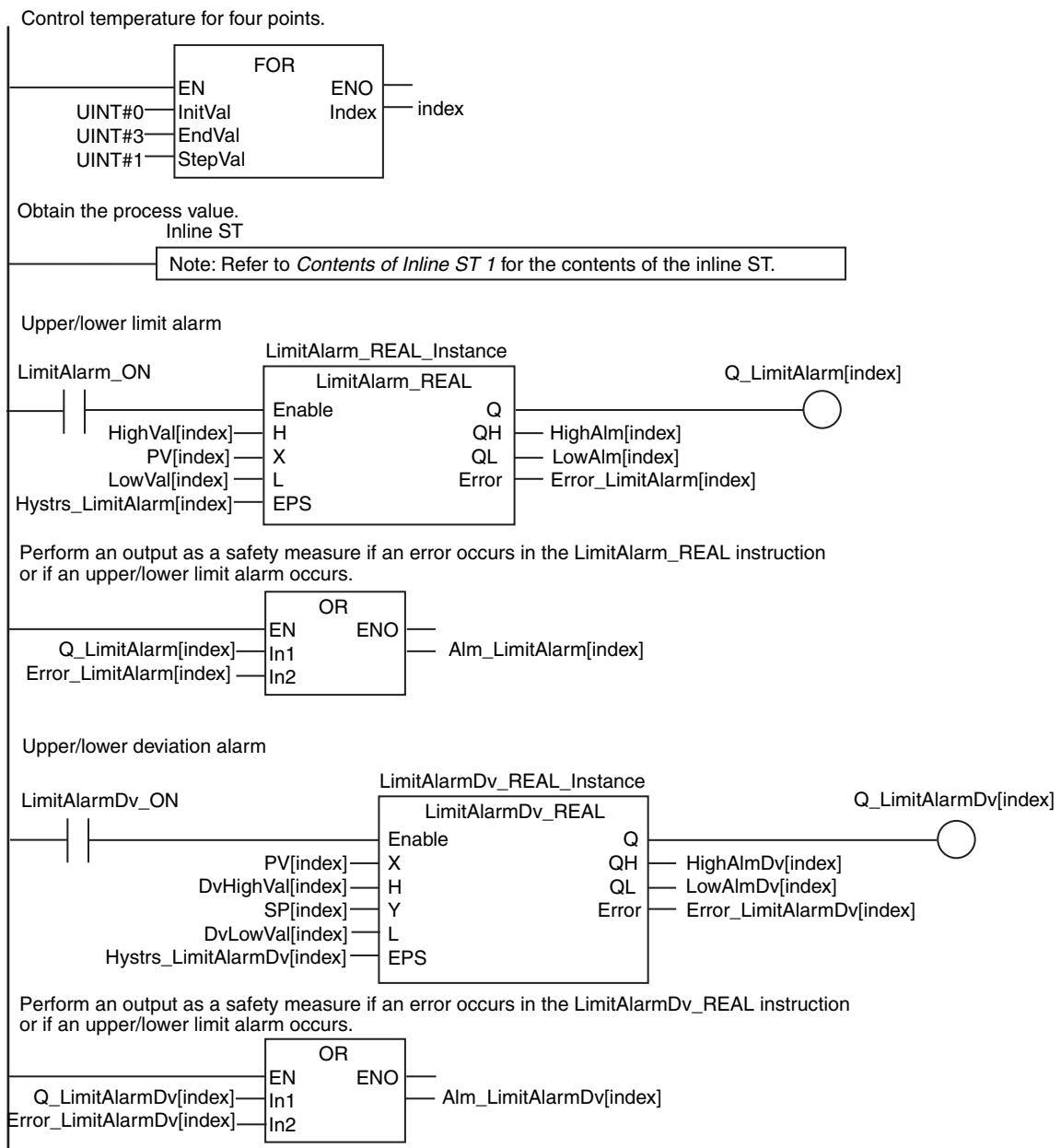

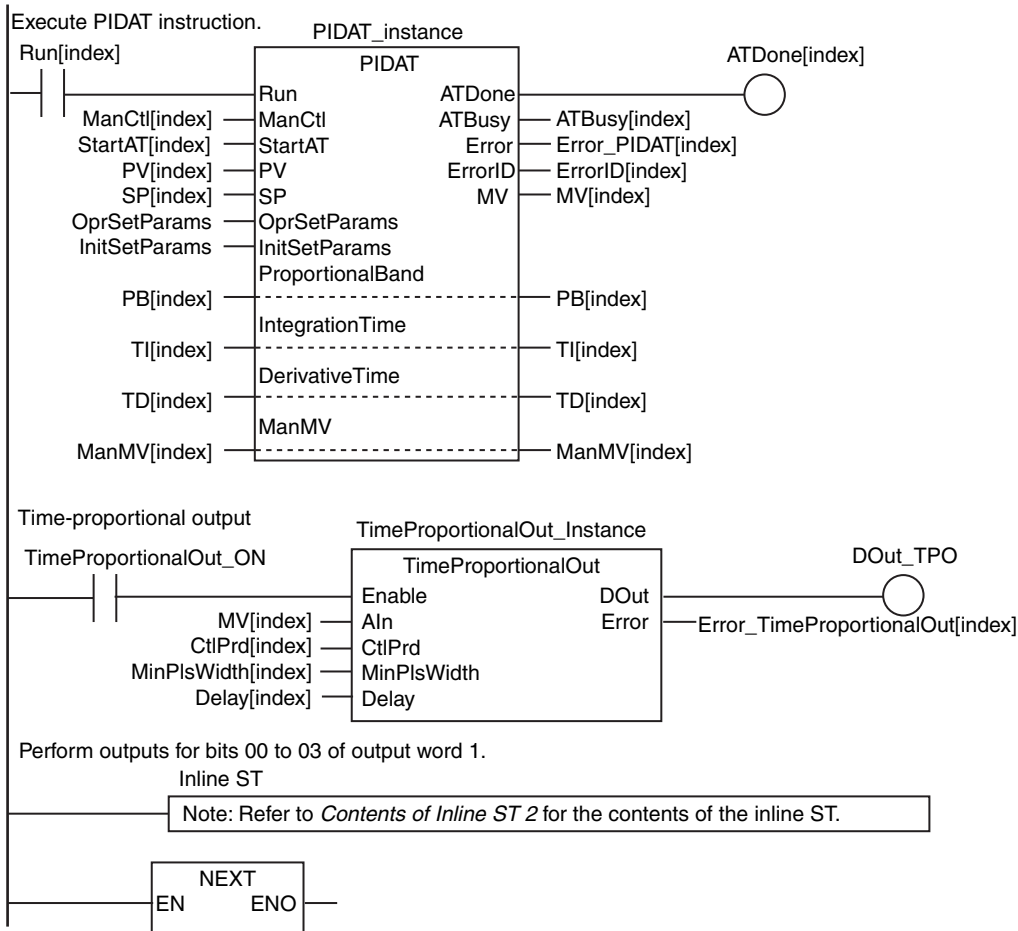

● Contents of Inline ST 1

```
// Get values of inputs 1 to 4.
CASE index OF
  INT#0:
    AI:=AI1;
  INT#1:
    AI:=AI2;
  INT#2:
    AI:=AI3;
  ELSE
    AI:=AI4;
END_CASE;

// Convert PV AI to real number.
PV[index]:=INT_TO_REAL(AI)/REAL#10.0;
// CJ1W-PH41U output is ten times the process value, so divide by 10.0.
```

● Contents of Inline ST 2

```
// Perform outputs for bits 00 to 03 of output word 1.
CASE index OF
  INT#0:
    DO1:=DOut_TPO;
  INT#1:
    DO2:=DOut_TPO;
  INT#2:
    DO3:=DOut_TPO;
  ELSE
    DO4:=DOut_TPO;
END_CASE;
```

ST

Name	Data type	Default	Retain	Comment
index	UINT	0		Loop index
LimitAlarm_ON	BOOL	True		Execution of Upper/Lower Limit Alarm instruction
LimitAlarmDv_ON	BOOL	True		Execution of Upper/Lower Deviation Alarm instruction
TimeProportionalOutput_ON	BOOL	True		Execution of Time-proportional Output instruction
AI	INT	0		Present value
PV	ARRAY[0..3] OF REAL	[4(0.0)]		Process value
SP	ARRAY[0..3] OF REAL	[4(100)]		Set point
DOut_TPO	BOOL	False		Time-proportional output
HighVal	ARRAY[0..3] OF REAL	[4(200)]		Upper limit set value of upper/lower limit alarm
LowVal	ARRAY[0..3] OF REAL	[4(0.0)]		Lower limit set value of upper/lower limit alarm
Hysters_LimitAlarm	ARRAY[0..3] OF REAL	[4(5)]		Hysteresis of upper/lower limit alarm
Q_LimitAlarm	ARRAY[0..3] OF BOOL	[4(False)]		Upper/lower limit alarm output
HighAlm	ARRAY[0..3] OF BOOL	[4(False)]		Upper limit alarm
LowAlm	ARRAY[0..3] OF BOOL	[4(False)]		Lower limit alarm
Error_LimitAlarm	ARRAY[0..3] OF BOOL	[4(False)]		Error in LimitAlarm_REAL instruction
Alm_LimitAlarm	ARRAY[0..3] OF BOOL	[4(False)]		Output for safety measure for Upper/Lower Limit Alarm instruction
DvHighVal	ARRAY[0..3] OF REAL	[4(50)]		Upper deviation set value of upper/lower deviation alarm
DvLowVal	ARRAY[0..3] OF REAL	[4(50)]		Lower deviation set value of upper/lower deviation alarm
Q_LimitAlarmDv	ARRAY[0..3] OF BOOL	[4(False)]		Upper/lower deviation alarm output
HighAlmDv	ARRAY[0..3] OF BOOL	[4(False)]		Upper deviation alarm
LowAlmDv	ARRAY[0..3] OF BOOL	[4(False)]		Lower deviation alarm
Error_LimitAlarmDv	ARRAY[0..3] OF BOOL	[4(False)]		Error in LimitAlarmDv_REAL instruction
Hysters_LimitAlarmDv	ARRAY[0..3] OF REAL	[4(3)]		Hysteresis of upper/lower deviation alarm
Alm_LimitAlarmDv	ARRAY[0..3] OF BOOL	[4(False)]		Output for safety measure for Upper/Lower Deviation Alarm instruction
Run	ARRAY[0..3] OF BOOL	[4(False)]		Execution condition
ManCtl	ARRAY[0..3] OF BOOL	[4(False)]		Manual/auto control
StartAT	ARRAY[0..3] OF BOOL	[4(False)]		Autotuning execution condition

Name	Data type	Default	Retain	Comment
OprSetParams	_sOPR_SET_PARAMS	(MVLowLmt:=0.0, MVUpLmt:=100.0, ManResetVal:=0.0, MVTrackSw:=False, MVTrackVal:=0.0, StopMV:=0.0, ErrorMV:=0.0, Alpha:=0.65, ATCalcGain:=1.0, ATHystrs:=0.2)		Operation setting parameters
InitSetParams	_sINIT_SET_PARAMS	(SampTime:=T#100ms, RngLowLmt:=-10.0, RngUpLmt:=1000.0, DirOpr:=False)		Initial setting parameters
PB	ARRAY[0..3] OF REAL	[4(10)]	✓	Proportional band
TI	ARRAY[0..3] OF TIME	[4(T#0S)]	✓	Integration time
TD	ARRAY[0..3] OF TIME	[4(T#0S)]	✓	Derivative time
ManMV	ARRAY[0..3] OF REAL	[4(0.0)]		Manual manipulated variable
ATDone	ARRAY[0..3] OF BOOL	[4(False)]		Autotuning normal completion
ATBusy	ARRAY[0..3] OF BOOL	[4(False)]		Autotuning busy
Error_PIDAT	ARRAY[0..3] OF BOOL	[4(False)]		Error in PIDAT instruction
ErrorID	ARRAY[0..3] OF WORD	[4(16#0)]		Error ID for PIDAT instruction
MV	ARRAY[0..3] OF REAL	[4(0.0)]		Manipulated variable
CtlPrd	ARRAY[0..3] OF TIME	[4(T#1s)]		Control period
MinPlsWidth	ARRAY[0..3] OF REAL	[4(0.0)]		Minimum pulse width
Delay	ARRAY[0..3] OF REAL	[4(0.0)]		ON-delay time
Error_TimeProportionalOut	ARRAY[0..3] OF BOOL	[4(False)]		Error in TimeProportionalOut instruction
LimitAlarm_REAL_instance	LimitAlarm_REAL			
LimitAlarmDv_REAL_instance	LimitAlarmDv_REAL			
PIDAT_instance	PIDAT			
TimeProportionalOut_instance	TimeProportionalOut			

```
// Control temperature for four points.
FOR index:=UINT#0 TO UINT#3 BY UINT#1 DO

  // Get values of inputs 1 to 4.
  CASE index OF
    INT#0:
      AI:=AI1;
    INT#1:
      AI:=AI2;
    INT#2:
      AI:=AI3;
    ELSE
      AI:=AI4;
  END_CASE;

  // Convert PV AI to real number.
  PV[index]:=INT_TO_REAL(AI)/REAL#10.0; // CJ1W-PH41U output is ten times
  // the process value, so divide by 10.0.

  // Upper/lower limit alarm
  LimitAlarm_REAL_instance(
    Enable :=LimitAlarm_ON,
```

```

H      :=HighVal[index],
X      :=PV[index],
L      :=LowVal[index],
EPS    :=Hystrs_LimitAlarm[index],
Q      =>Q_LimitAlarm[index],
QH     =>HighAlm[index],
QL     =>LowAlm[index],
Error  =>Error_LimitAlarm[index]);

// Perform an output as a safety measure if an error occurs in the
// LimitAlarmDv_REAL instruction or if an upper/lower limit alarm occurs.
Alm_LimitAlarm[index] :=Q_LimitAlarm[index] OR Error_LimitAlarm[index];

// Upper/lower deviation alarm
LimitAlarmDv_REAL_instance(
  Enable :=LimitAlarmDv_ON,
  X      :=PV[index],
  H      :=DvHighVal[index],
  Y      :=SP[index],
  L      :=DvLowVal[index],
  EPS    :=Hystrs_LimitAlarmDv[index],
  Q      =>Q_LimitAlarmDv[index],
  QH     =>HighAlmDv[index],
  QL     =>LowAlmDv[index],
  Error  =>Error_LimitAlarmDv[index]);

// Perform an output as a safety measure if an error occurs in the
// LimitAlarmDv_REAL instruction or if an upper/lower limit alarm occurs.
Alm_LimitAlarmDv[index] :=Q_LimitAlarmDv[index] OR Error_LimitAlarmDv[index];

// Execute PIDAT instruction.
PIDAT_instance(
  Run           :=Run[index],
  ManCtl       :=ManCtl[index],
  StartAT      :=StartAT[index],
  PV           :=PV[index],
  SP           :=SP[index],
  OprSetParams :=OprSetParams,
  InitSetParams :=InitSetParams,
  ProportionalBand:=PB[index],
  IntegrationTime :=TI[index],
  DerivativeTime :=TD[index],
  ManMV        :=ManMV[index],
  ATDone       =>ATDone[index],
  ATBusy       =>ATBusy[index],
  Error        =>Error_PIDAT[index],
  ErrorID      =>ErrorID[index],
  MV           :=MV[index]);

// Time-proportional output
TimeProportionalOut_instance(
  Enable      :=TimeProportionalOut_ON,
  AIn        :=MV[index],
  CtlPrd     :=CtlPrd[index],
  MinPlsWidth :=MinPlsWidth[index],
  Delay      :=Delay[index],
  DOut       =>DOut_TPO,
  Error      =>Error_TimeProportionalOut[index]);

// Perform outputs for bits 00 to 03 of output word 1.
CASE index OF
  INT#0:
    DO1:=DOut_TPO;
  INT#1:
    DO2:=DOut_TPO;

```

```
INT#2 :  
    DO3 :=DOut_TPO;  
ELSE  
    DO4 :=DOut_TPO;  
END_CASE;  
  
END_FOR;
```

LimitAlarm_**

The LimitAlarm_** instruction outputs an alarm if the input value is below the lower limit set value or above the upper limit set value.

Instruction	Name	FB/ FUN	Graphic expression	ST expression
LimitAlarm_**	Upper/Lower Limit Alarm Group	FB	<p>*** must be REAL or LREAL.</p>	LimitAlarm_**_instance(Enable, H, X, L, EPS, Q, QH, QL, Error); *** must be REAL or LREAL.

Variables

Name	Meaning	I/O	Description	Valid range	Unit	Default
Enable	Enable	Input	TRUE: Execute FALSE: Reset alarm	Depends on data type.	---	FALSE
H	Upper limit set value		Upper limit set value for the input value			0
X	Input value		Value to monitor			
L	Lower limit set value		Lower limit set value for the input value			
EPS	Hysteresis		Hysteresis of the alarm			Depends on data type.*
Q	Alarm output	Output	TRUE: There is either an upper limit alarm or a lower limit alarm. FALSE: There is neither an upper limit alarm nor a lower limit alarm.	Depends on data type.	---	---
QH	Upper limit alarm		TRUE: There is an upper limit alarm. FALSE: There is no upper limit alarm.			
QL	Lower limit alarm		TRUE: There is a lower limit alarm. FALSE: There is no lower limit alarm.			

* Negative numbers are excluded.

	Boolean	Bit strings				Integers							Real numbers		Times, durations, dates, and text strings					
	BOOL	BYTE	WORD	DWORD	LWORD	USINT	UINT	UDINT	ULINT	SINT	INT	DINT	LINT	REAL	LREAL	TIME	DATE	TOD	DT	STRING
Enable	OK																			
H														OK	OK					
X	Must be same data type as <i>H</i> .																			
L	Must be same data type as <i>H</i> .																			
EPS	Must be same data type as <i>H</i> .																			
Q	OK																			
QH	OK																			
QL	OK																			

Function

The LimitAlarm_** instruction monitors the input value to see if it is between the lower limit set value and the upper limit set value. The LimitAlarm_** instruction outputs an alarm if the input value is below the lower limit set value or above the upper limit set value. Use this instruction in temperature control, e.g., to monitor the process temperature.

Input value *X* is monitored while *Enable* is TRUE. If the value of *X* exceeds the value of upper limit set value *H*, upper limit alarm *QH* changes to TRUE. If the value of *X* goes below the value of lower limit set value *L*, lower limit alarm *QL* changes to TRUE. If the value of either *QH* or *QL* is TRUE, the value of alarm output *Q* is TRUE. The values of *X*, *H*, *L*, and hysteresis *EPS* are continuously updated while *Enable* is TRUE.

If *Enable* changes to FALSE, the alarm is reset. When the alarm is reset, *Q*, *QH*, and *QL* change to FALSE.

The data types of *H*, *X*, *L*, and *EPS* must be either REAL or LREAL. The name of the instruction is determined by the data types of *H*, *X*, *L*, and *EPS*. If the name of the instruction is LimitAlarm_LREAL, the data types of *H*, *X*, *L*, and *EPS* are all LREAL.

Operation of Upper Limit Alarm QH

The value of upper limit alarm *QH* changes as shown below. You can set the hysteresis to prevent hunting in the limit alarm.

- If Input value *X* > Upper limit set value *H*, then *QH* is TRUE.
- If Input value *X* < Upper limit set value *H* – Hysteresis *EPS*, then *QH* is FALSE.

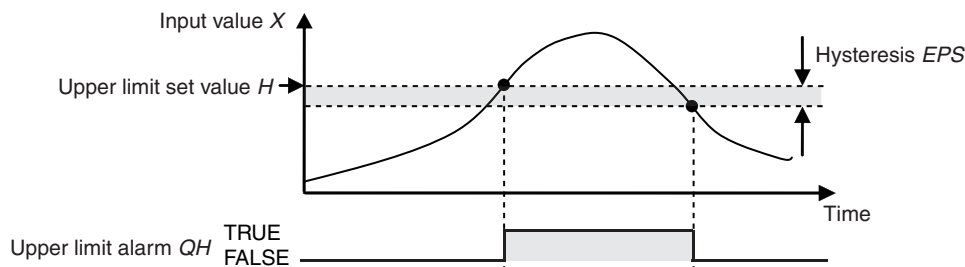

Operation of Lower Limit Alarm QL

The value of lower limit alarm *QL* changes as shown below. You can set the hysteresis to prevent hunting in the limit alarm.

- If Input value *X* < Lower limit set value *L*, then *QL* is TRUE.
- If Input value *X* > Lower limit set value *L* + Hysteresis *EPS*, then *QL* is FALSE.

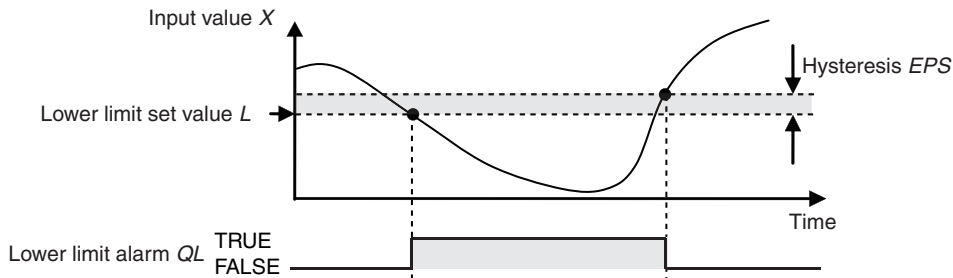

Notation Example

The following notation example sets upper limit set value *H* to 100°C, lower limit set value *L* to 50°C, and hysteresis *EPS* to 10°C.

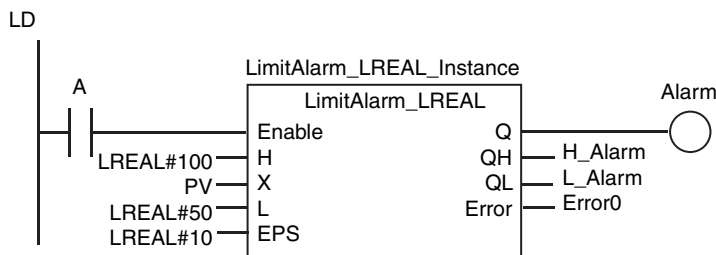

ST

```
LimitAlarm_LREAL_instance(A,LREAL#100,PV,LREAL#50,LREAL#10,Alarm,H_Alarm,L_Alarm,Error0);
```

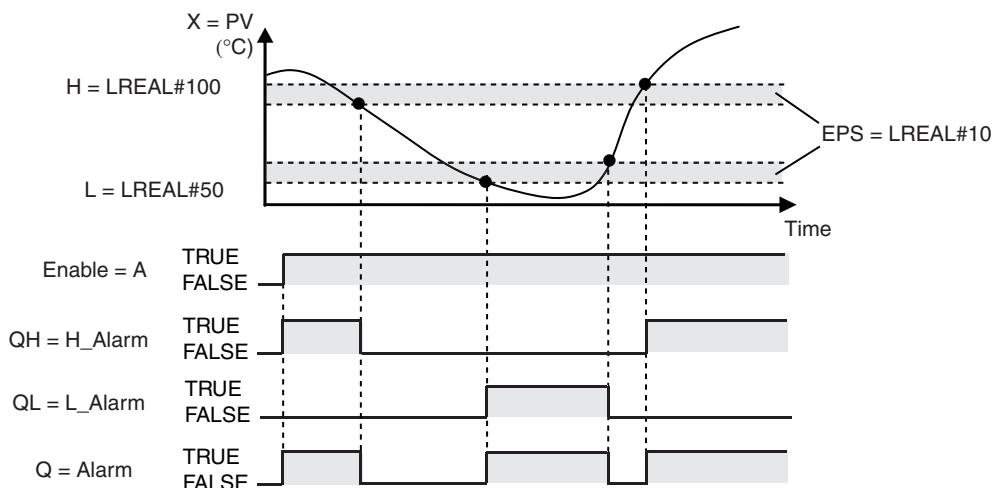

Additional Information

- Use the LimitAlarm_REAL instruction to reduce the instruction execution time.
- You can set *EPS* to less than $H - L$. If you do so, both *QH* and *QL* can be TRUE at the same time.

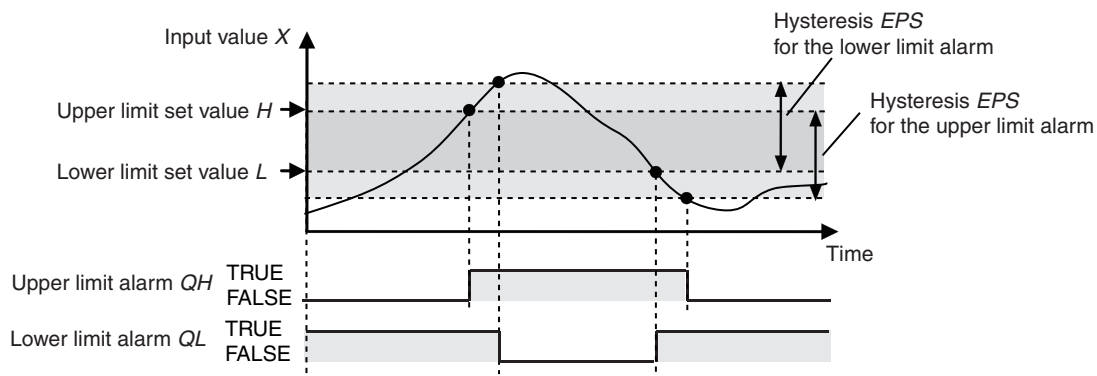

- You can set H and L so that $H < L$. If you do so, either QH or QL will always be TRUE.

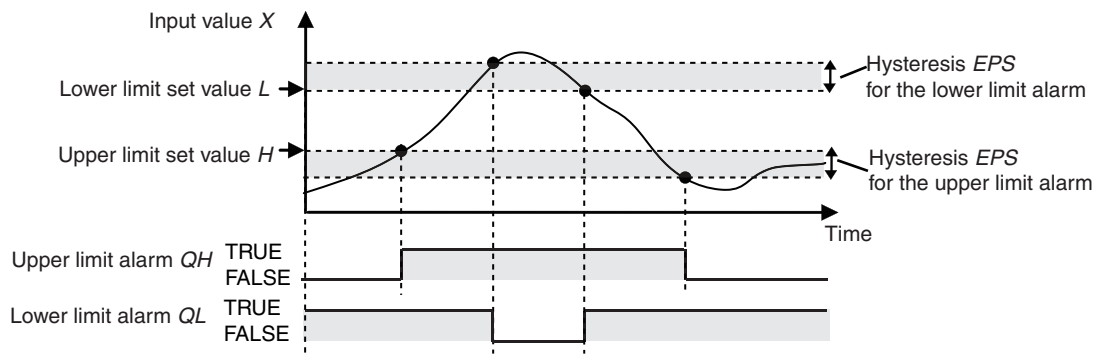

Precautions for Correct Use

- An error occurs if the value of *EPS* is outside of the valid range. *Error* changes to TRUE, and *Q*, *QH*, and *QL* change to FALSE.
- You can use this instruction for safety measures, for example, to turn OFF a temperature control output when an alarm is output. If you do so, design the safety measures so that safety is maintained even when an error causes *Q*, *QH*, and *HL* to change to FALSE. For an application example, refer to the sample programming that is provided for the TimeProportionalOut instruction (page 2-729).



Version Information

A CPU Unit with unit version 1.02 or later and Sysmac Studio version 1.03 or higher are required to use this instruction.

Sample Programming

Refer to the sample programming that is provided for the TimeProportionalOut instruction (page 2-729).

LimitAlarmDv_**

The LimitAlarmDv_** instruction outputs an alarm if the deviation in the input value from the reference value exceeds the lower deviation set value or the upper deviation set value.

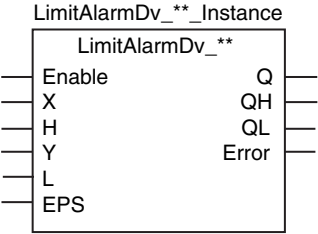
Instruction	Name	FB/ FUN	Graphic expression	ST expression
LimitAlarmDv_**	Upper/Lower Deviation Alarm Group	FB	 <p>*** must be REAL or LREAL.</p>	LimitAlarmDv_**instance(Enable, X, H, Y, L, EPS, Q, QH, QL, Error); *** must be REAL or LREAL.

Variables

Name	Meaning	I/O	Description	Valid range	Unit	Default
Enable	Enable	Input	TRUE: Execute FALSE: Reset alarm	Depends on data type.	---	FALSE
X	Input value		Value to monitor			0
H	Upper deviation set value		Set value for an alarm for an upward deviation in respect to the reference value			
Y	Reference value		Reference value for deviation			
L	Lower deviation set value		Set value for an alarm for a downward deviation in respect to the reference value			
EPS	Hysteresis		Hysteresis of the alarm			
Q	Deviation alarm output	Output	TRUE: There is either an upper deviation alarm or a lower deviation alarm. FALSE: There is neither an upper deviation alarm nor a lower deviation alarm.	Depends on data type.	---	---
QH	Upper deviation alarm		TRUE: There is an upper deviation alarm. FALSE: There is no upper deviation alarm.			
QL	Lower deviation alarm		TRUE: There is a lower deviation alarm. FALSE: There is no lower deviation alarm.			

* Negative numbers are excluded.

	Boolean	Bit strings				Integers							Real numbers		Times, durations, dates, and text strings						
	BOOL	BYTE	WORD	DWORD	LWORD	USINT	UINT	UDINT	ULINT	SINT	INT	DINT	LINT	REAL	LREAL	TIME	DATE	TOD	DT	STRING	
Enable	OK																				
X														OK	OK						
H	Must be same data type as X.																				
Y	Must be same data type as X.																				
L	Must be same data type as X.																				
EPS	Must be same data type as X.																				
Q	OK																				
QH	OK																				
QL	OK																				

Function

The `LimitAlarmDv_**` instruction monitors the deviation in the input value from the reference value to see if it exceeds the lower deviation set value or the upper deviation set value. If the deviation exceeds the lower deviation set value or the upper deviation set value, the instruction outputs an alarm. Use this instruction in temperature control, e.g., to monitor the deviation in the process temperature from the set point.

The deviation in input value *X* from the reference value *Y* is monitored while *Enable* is TRUE. If the upward deviation in *X* from *Y* exceeds the value of upper deviation set value *H*, upper deviation alarm *QH* changes to TRUE. If the downward deviation in *X* from *Y* exceeds the value of lower deviation set value *L*, lower deviation alarm *QL* changes to TRUE. If the value of either *QH* or *QL* is TRUE, the value of alarm output *Q* is TRUE. The values of *X*, *H*, *Y*, *L*, and hysteresis *EPS* are continuously updated while *Enable* is TRUE.

If *Enable* changes to FALSE, the alarm is reset. When the alarm is reset, *Q*, *QH*, and *QL* change to FALSE.

The data types of *X*, *H*, *Y*, *L*, and *EPS* must be either REAL or LREAL. The name of the instruction is determined by the data types of *X*, *H*, *Y*, *L*, and *EPS*. If the name of the instruction is `LimitAlarmDv_L-REAL`, the data types of *X*, *H*, *Y*, *L*, and *EPS* are all LREAL.

Operation of Upper Deviation Alarm QH

Upper deviation alarm QH is the alarm for an upward deviation in respect to reference value Y . The value of QH changes as shown below. You can set the hysteresis to prevent hunting in the deviation alarm.

- If Input value X – Reference value $Y >$ Upper deviation set value H , then QH is TRUE.
- If Input value X – Reference value $Y <$ Upper deviation set value H – Hysteresis EPS , then QH is FALSE.

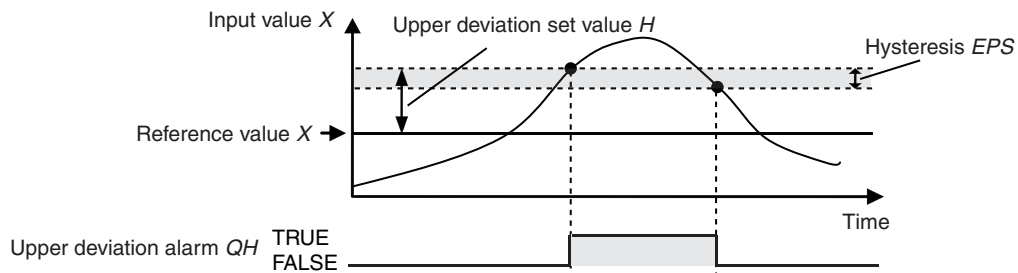

Operation of Lower Deviation Alarm QL

Lower deviation alarm QL is the alarm for a downward deviation in respect to reference value Y . The value of QL changes as shown below. You can set the hysteresis to prevent hunting in the deviation alarm.

- If $-(\text{Input value } X - \text{Reference value } Y) >$ Lower deviation set value L , then QL is TRUE.
- If $-(\text{Input value } X - \text{Reference value } Y) <$ Lower deviation set value L – Hysteresis EPS , then QL is FALSE.

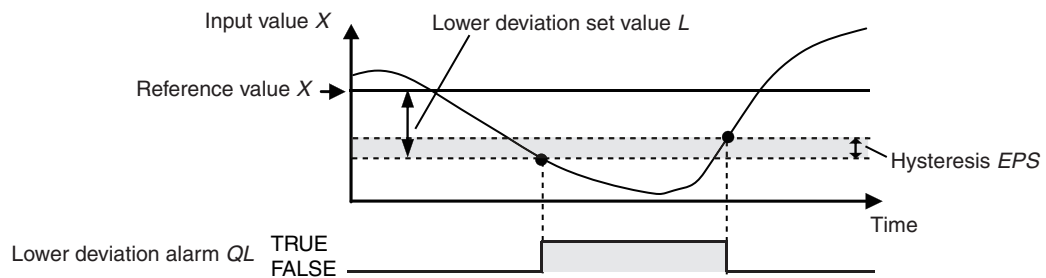

Notation Example

The following notation example sets upper deviation set value H to 50°C, lower deviation set value L to 40°C, and hysteresis EPS to 10°C.

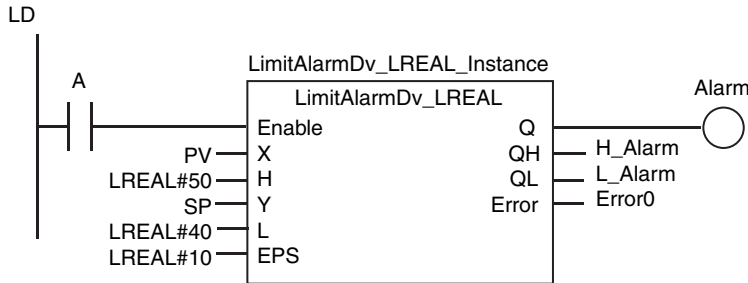

ST

```
LimitAlarmDv_LREAL_instance(A,PV,LREAL#50,SP,LREAL#40,LREAL#10,Alarm,H_Alarm,L_Alarm,Error0);
```

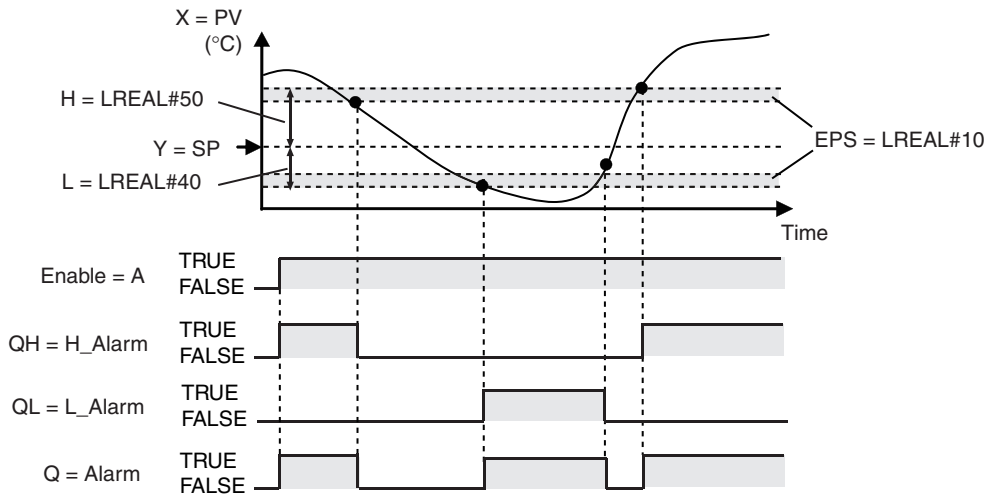

Additional Information

- Use the LimitAlarmDv_REAL instruction to reduce the instruction execution time.
- You can set EPS to less than $H + L$. If you do so, both QH and QL can be TRUE at the same time.

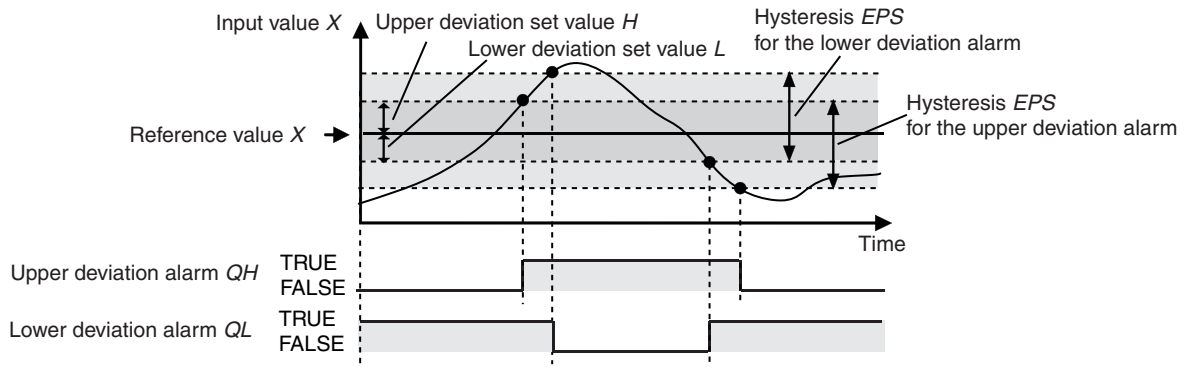

- You can set H and L so that $H + L = 0$. If you do so, either QH or QL will always be TRUE. For example, the following figure shows the operation when the value of L is -60 and the value of H is 30 .

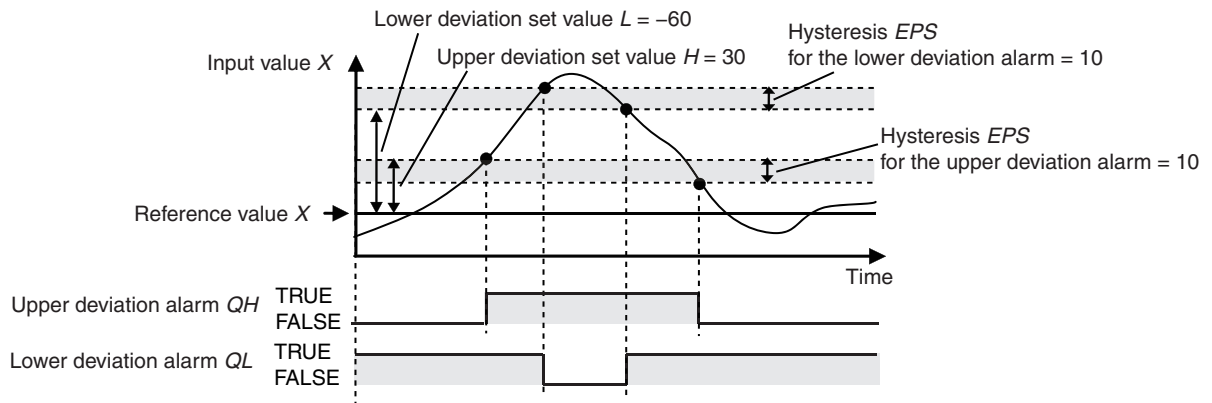

Precautions for Correct Use

- An error occurs if the value of EPS is outside of the valid range. $Error$ changes to TRUE, and Q , QH , and QL change to FALSE.
- You can use this instruction for safety measures, for example, to turn OFF a temperature control output when a deviation alarm is output. If you do so, design the safety measures so that safety is maintained even when an error causes Q , QH , and HL to change to FALSE. For an application example, refer to the sample programming that is provided for the TimeProportionalOut instruction (page 2-729).

Version Information

A CPU Unit with unit version 1.02 or later and Sysmac Studio version 1.03 or higher are required to use this instruction.

Sample Programming

Refer to the sample programming that is provided for the TimeProportionalOut instruction (page 2-729).

LimitAlarmDvStbySeq_**

The LimitAlarmDvStbySeq_** instruction outputs upper and lower deviation alarms with a standby sequence.

Instruction	Name	FB/ FUN	Graphic expression	ST expression
LimitAlarmDvStbySeq_**	Upper/Lower Deviation Alarm with Standby Sequence Group	FB	<p>*** must be REAL or LREAL.</p>	<pre>LimitAlarmDvStbySeq_**_instance(Enable, X, H, Y, L, EPS, Q, QH, QL, StbySeqFlag, Error);</pre> <p>*** must be REAL or LREAL.</p>

Variables

Name	Meaning	I/O	Description	Valid range	Unit	Default
Enable	Enable	Input	TRUE: Execute FALSE: Reset alarm	Depends on data type.	---	FALSE
X	Input value		Value for deviation alarm			0
H	Upper deviation set value		Set value for an alarm for an upward deviation in respect to the reference value			
Y	Reference value		Reference value for deviation			
L	Lower deviation set value		Set value for an alarm for a downward deviation in respect to the reference value			
EPS	Hysteresis		Hysteresis of the alarm			
Q	Deviation alarm output	Output	TRUE: There is either an upper deviation alarm or a lower deviation alarm. FALSE: There is neither an upper deviation alarm nor a lower deviation alarm.	Depends on data type.	---	---
QH	Upper deviation alarm		TRUE: There is an upper deviation alarm. FALSE: There is no upper deviation alarm.			
QL	Lower deviation alarm		TRUE: There is a lower deviation alarm. FALSE: There is no lower deviation alarm.			
StbySeq Flag	Standby Sequence Enabled Flag		TRUE: Enabled FALSE: Disabled			

* Negative numbers are excluded.

	Boolean	Bit strings				Integers							Real numbers		Times, durations, dates, and text strings						
	BOOL	BYTE	WORD	DWORD	LWORD	USINT	UINT	UDINT	ULINT	SINT	INT	DINT	LINT	REAL	LREAL	TIME	DATE	TOD	DT	STRING	
Enable	OK																				
X														OK	OK						
H	Must be same data type as X.																				
Y	Must be same data type as X.																				
L	Must be same data type as X.																				
EPS	Must be same data type as X.																				
Q	OK																				
QH	OK																				
QL	OK																				
StbySeq Flag	OK																				

Function

The LimitAlarmDvStbySeq_** instruction monitors the deviation in the input value from the reference value to see if it exceeds the lower deviation set value or the upper deviation set value. If the deviation exceeds the lower deviation set value or the upper deviation set value, the instruction outputs an alarm. However, the instruction will not output an alarm until the reference value first goes to between the lower and upper deviation set values. Use this instruction in temperature control, e.g., to not output a deviation alarm until the process temperature is stable.

The deviation in input value *X* from the reference value *Y* is monitored while *Enable* is TRUE. However, the deviation is not monitored while Standby Sequence Enabled Flag *StbySeqFlag* is TRUE. If the upper deviation in *X* from *Y* exceeds the value of upper deviation set value *H*, upper deviation alarm *QH* changes to TRUE. If the lower deviation in *X* from *Y* exceeds the value of lower deviation set value *L*, lower deviation alarm *QL* changes to TRUE. If the value of either *QH* or *QL* is TRUE, the value of alarm output *Q* is TRUE. The values of *X*, *H*, *Y*, *L*, and *EPS* are continuously updated while *Enable* is TRUE.

If *Enable* changes to FALSE, the alarm is reset. When the alarm is reset, *Q*, *QH*, *QL*, and *StbySeqFlag* change to FALSE.

StbySeqFlag changes to FALSE when all of the following conditions are met after *Enable* changes to TRUE. After *StbySeqFlag* changes to FALSE, it will not change to TRUE until *Enable* changes from FALSE to TRUE.

- Input value X – Reference value $Y < \text{Upper deviation set value } H - \text{Hysteresis } EPS$
- $-(\text{Input value } X - \text{Reference value } Y) < \text{Lower deviation set value } L - \text{Hysteresis } EPS$

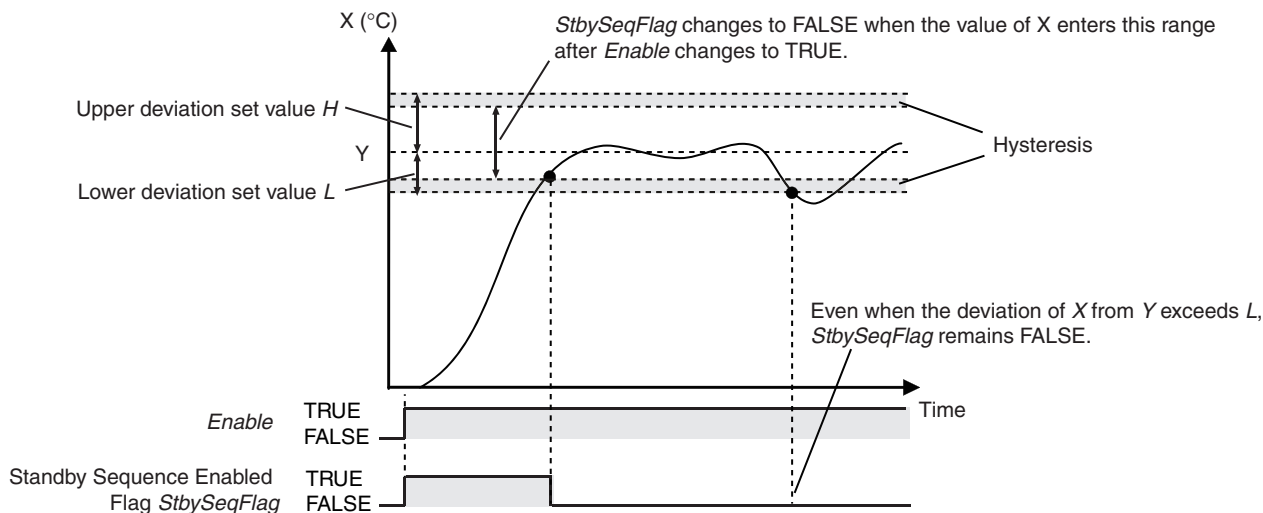

The data types of X , H , Y , L , and EPS must be either REAL or LREAL. The name of the instruction is determined by the data types of X , H , Y , L , and EPS . If the name of the instruction is LimitAlarmDvStbySeq_LREAL, the data types of X , H , Y , L , and EPS are all LREAL.

Operation of Upper Deviation Alarm QH

Upper deviation alarm QH is the alarm for an upward deviation in respect to reference value Y . The value of QH changes as shown below while *StbySeqFlag* is FALSE. You can set the hysteresis to prevent hunting in the deviation alarm.

- If Input value $X - \text{Reference value } Y > \text{Upper deviation set value } H$, then QH is TRUE.
- If Input value $X - \text{Reference value } Y < \text{Upper deviation set value } H - \text{Hysteresis } EPS$, then QH is FALSE.

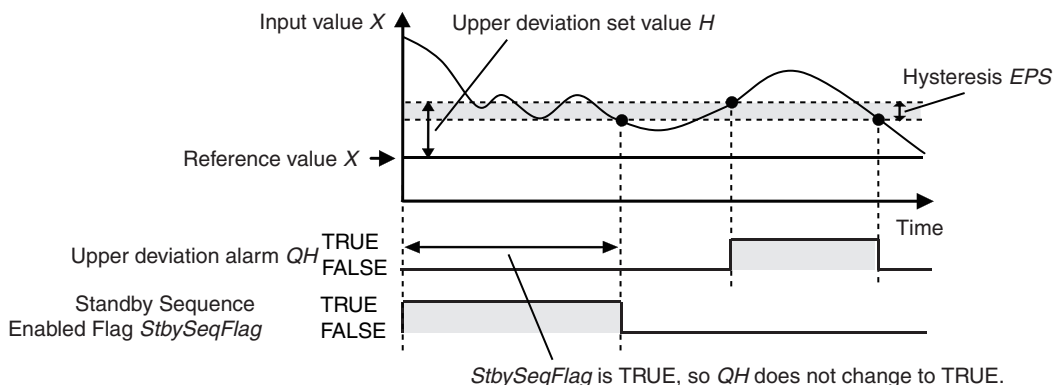

Operation of Lower Deviation Alarm QL

Lower deviation alarm QL is the alarm for a downward deviation in respect to reference value Y . The value of QL changes as shown below while *StbySeqFlag* is FALSE. You can set the hysteresis to prevent hunting in the deviation alarm.

- If $-(\text{Input value } X - \text{Reference value } Y) > \text{Lower deviation set value } L$, then QL is TRUE.

- If $-(\text{Input value } X - \text{Reference value } Y) < \text{Lower deviation set value } L - \text{Hysteresis } EPS$, then QL is FALSE.

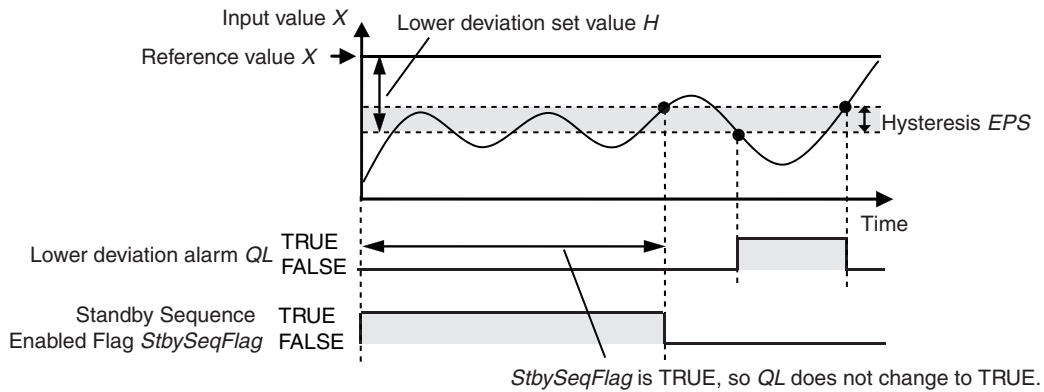

Notation Example

The following notation example sets upper deviation set value H to 50°C , lower deviation set value L to 40°C , and hysteresis EPS to 10°C .

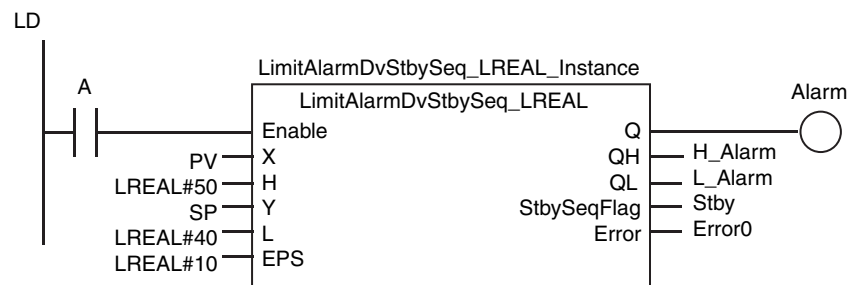

```
ST
LimitAlarmDvStbySeq_LREAL_Instance(A,PV,LREAL#50,SP,LREAL#40,LREAL#10,Alarm,H_Alarm,L_Alarm,Stby>Error0);
```

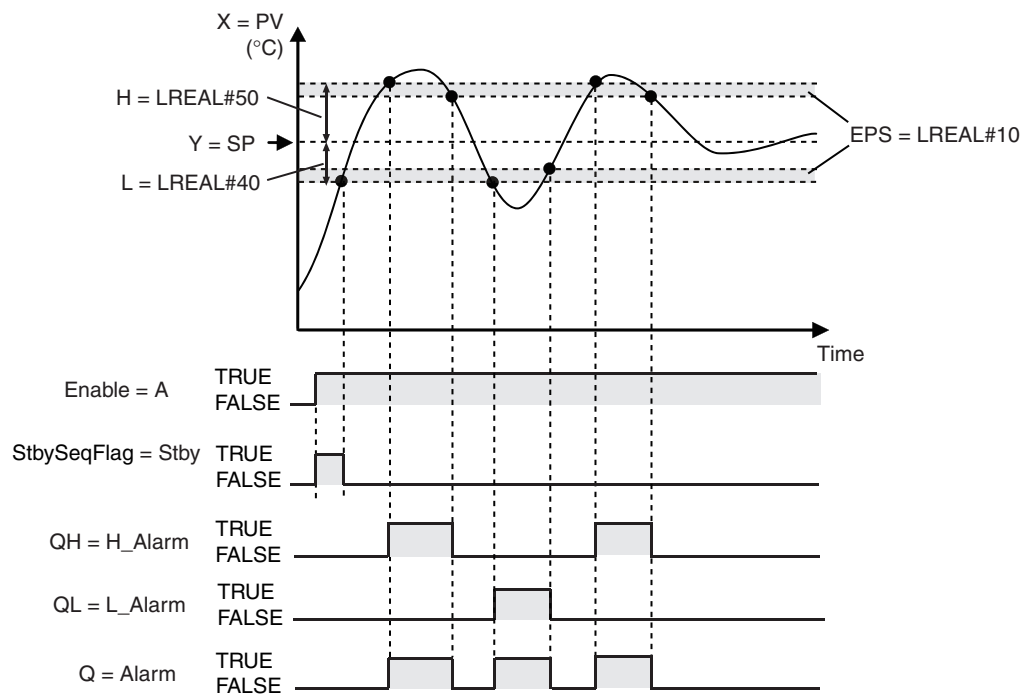

Additional Information

- Use the `LimitAlarmDvStbySeq_REAL` instruction to reduce the instruction execution time.
- You can set `EPS` to less than $H + L$. If you do so, both `QH` and `QL` can be `TRUE` at the same time. Refer to the *LimitAlarmDv_** instruction* (page 2-749).
- You can set `H` and `L` so that $H + L < 0$. If you do so, either `QH` or `QL` will always be `TRUE` while `StbySeqFlag` is `FALSE`. Refer to the *LimitAlarmDv_** instruction* (page 2-749).

Precautions for Correct Use

- An error occurs if the value of `EPS` is outside of the valid range. `Error` changes to `TRUE`, and `Q`, `QH`, and `QL` change to `FALSE`.
- You can use this instruction for safety measures, for example, to turn OFF a temperature control output when a deviation alarm is output. If you do so, design the safety measures so that safety is maintained even when an error causes `Q`, `QH`, and `QL` to change to `FALSE`. Refer to *Sample Programming* for an application example.



Version Information

A CPU Unit with unit version 1.02 or later and Sysmac Studio version 1.03 or higher are required to use this instruction.

Sample Programming

This sample performs temperature control for four points with upper/lower limit alarms and upper/lower deviation alarms with standby sequences. PID control is performed. The manipulated variables of PID control are converted to time-proportional output values that are output to heating devices.



Specifications

Temperature control is performed according to the following specifications.

Item	Specification
Input Unit	CJ1W-PH41U Isolated-type Universal Input Unit
Input types	K thermocouples
Output Unit	CJ1W-OD212 Transistor Output Unit
Set point	100°C
Upper limit of temperature	200°C
Lower limit of temperature	0°C
Hysteresis of upper/lower limit alarm	5°C
Upper deviation temperature	50°C
Lower deviation temperature	50°C
Hysteresis of upper/lower deviation alarm	3°C
Sampling period for PID control	100 ms
Output control period	1 s

Configuration and Settings

The following settings are used for the CJ1W-PH41U Input Unit.

Item	Set value
Input1:Input signal type	K(1)
Input2:Input signal type	K(1)
Input3:Input signal type	K(1)
Input4:Input signal type	K(1)

The following I/O map settings are used.

Unit	I/O port	Description	Variable
CJ1W-PH41U	Ch1_AllnPv	Process value for input 1 (INT data)	AI1
	Ch2_AllnPv	Process value for input 2 (INT data)	AI2
	Ch3_AllnPv	Process value for input 3 (INT data)	AI3
	Ch4_AllnPv	Process value for input 4 (INT data)	AI4
CJ1W-OD212	Ch1_Out00	Bit 00 of output word 1	DO1
	Ch1_Out01	Bit 01 of output word 1	DO2
	Ch1_Out02	Bit 02 of output word 1	DO3
	Ch1_Out03	Bit 03 of output word 1	DO4

The inputs and outputs for the temperature control for the four points correspond as shown below.

Input	Output
AI1	DO1
AI2	DO2
AI3	DO3
AI4	DO4

The task period of the task to which the program is assigned is 1 ms.

● Configuration Diagram

Refer to the sample programming that is provided for the TimeProportionalOut instruction (page 2-729).

Processing

Perform the following procedure for all four points.

- 1** Get the process temperature.
- 2** Use the LimitAlarm_REAL instruction to output upper/lower limit alarms for the process temperature.
- 3** Perform an output as a safety measure if an error occurs in the LimitAlarm_REAL instruction or if an upper/lower limit alarm occurs.

- 4** Use the LimitAlarmDvStbySeq_REAL instruction to output upper/lower deviation alarms with a standby sequence for the deviation between the set point and the process temperature.
- 5** Perform an output as a safety measure if an error occurs in the LimitAlarmDvStbySeq_REAL instruction or if an upper/lower deviation alarm occurs.
- 6** Perform temperature control with the PIDAT instruction.
- 7** Use the TimeProportionalOut instruction to output the manipulated variable as a time-proportional value to the heating device.

● Operation of Upper/Lower Limit Alarms and Upper/Lower Deviation Alarms with Standby Sequence

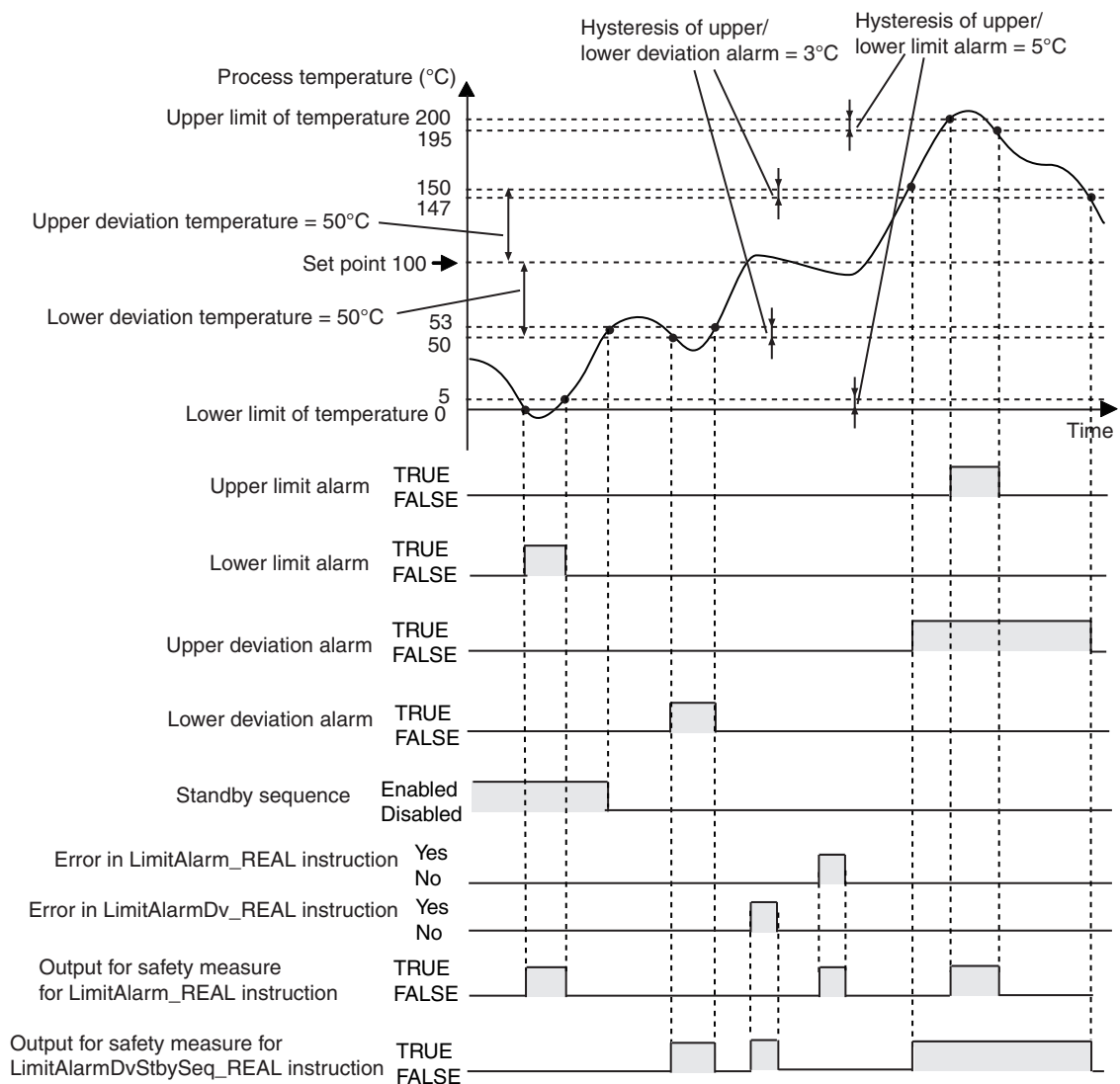

Application Programming

LD

Name	Data type	Default	Retain	Comment
index	UINT	0		Loop index
LimitAlarm_ON	BOOL	True		Execution of Upper/Lower Limit Alarm instruction
LimitAlarmDvStbySeq_ON	BOOL	True		Execution of Upper/Lower Deviation Alarm with Standby Sequence instruction
TimeProportionalOutput_ON	BOOL	True		Execution of TimeProportionalOut instruction
AI	INT	0		Present value
PV	ARRAY[0..3] OF REAL	[4(0.0)]		Process value
SP	ARRAY[0..3] OF REAL	[4(100)]		Set point
DOut_TPO	BOOL	False		Time-proportional output
HighVal	ARRAY[0..3] OF REAL	[4(200)]		Upper limit set value of upper/lower limit alarm
LowVal	ARRAY[0..3] OF REAL	[4(0.0)]		Lower limit set value of upper/lower limit alarm
Hysters_LimitAlarm	ARRAY[0..3] OF REAL	[4(5)]		Hysteresis of upper/lower limit alarm
Q_LimitAlarm	ARRAY[0..3] OF BOOL	[4(False)]		Upper/lower limit alarm output
HighAlm	ARRAY[0..3] OF BOOL	[4(False)]		Upper limit alarm
LowAlm	ARRAY[0..3] OF BOOL	[4(False)]		Lower limit alarm
Error_LimitAlarm	ARRAY[0..3] OF BOOL	[4(False)]		Error in LimitAlarm_REAL instruction
Alm_LimitAlarm	ARRAY[0..3] OF BOOL	[4(False)]		Output for safety measure for Upper/Lower Limit Alarm instruction
DvHighVal	ARRAY[0..3] OF REAL	[4(50)]		Upper deviation set value of upper/lower deviation alarm
DvLowVal	ARRAY[0..3] OF REAL	[4(50)]		Lower deviation set value of upper/lower deviation alarm
Q_LimitAlarmDv	ARRAY[0..3] OF BOOL	[4(False)]		Upper/lower deviation alarm output
HighAlmDv	ARRAY[0..3] OF BOOL	[4(False)]		Upper deviation alarm
LowAlmDv	ARRAY[0..3] OF BOOL	[4(False)]		Lower deviation alarm
StbySeqFlag	ARRAY[0..3] OF BOOL	[4(False)]		Standby Sequence Enabled Flag
Error_LimitAlarmDvStbySeq	ARRAY[0..3] OF BOOL	[4(False)]		Error in LimitAlarmDvStbySeq_REAL instruction
Hysters_LimitAlarmDv	ARRAY[0..3] OF REAL	[4(3)]		Hysteresis of upper/lower deviation alarm

Name	Data type	Default	Retain	Comment
Alm_LimitAlarmDv	ARRAY[0..3] OF BOOL	[4(False)]		Output for safety measure for Upper/Lower Deviation Alarm instruction
Run	ARRAY[0..3] OF BOOL	[4(False)]		Execution condition
ManCtl	ARRAY[0..3] OF BOOL	[4(False)]		Manual/auto control
StartAT	ARRAY[0..3] OF BOOL	[4(False)]		Autotuning execution condition
OprSetParams	_sOPR_SET_PARAMS	(MVLowLmt:=0.0, MVUpLmt:=100.0, ManResetVal:=0.0, MVTrackSw:=False, MVTrackVal:=0.0, StopMV:=0.0, ErrorMV:=0.0, Alpha:=0.65, ATCalcGain:=1.0, ATHystrs:=0.2)		Operation setting parameters
InitSetParams	_sINIT_SET_PARAMS	(SampTime:=T#100ms, RngLow-Lmt:=-10.0, RngUpLmt:=1000.0, DirOpr:=False)		Initial setting parameters
PB	ARRAY[0..3] OF REAL	[4(10)]	✓	Proportional band
TI	ARRAY[0..3] OF TIME	[4(T#0S)]	✓	Integration time
TD	ARRAY[0..3] OF TIME	[4(T#0S)]	✓	Derivative time
ManMV	ARRAY[0..3] OF REAL	[4(0.0)]		Manual manipulated variable
ATDone	ARRAY[0..3] OF BOOL	[4(False)]		Autotuning normal completion
ATBusy	ARRAY[0..3] OF BOOL	[4(False)]		Autotuning busy
Error_PIDAT	ARRAY[0..3] OF BOOL	[4(False)]		Error in PIDAT instruction
ErrorID	ARRAY[0..3] OF WORD	[4(16#0)]		Error ID for PIDAT instruction
MV	ARRAY[0..3] OF REAL	[4(0.0)]		Manipulated variable
CtlPrd	ARRAY[0..3] OF TIME	[4(T#1s)]		Control period
MinPlsWidth	ARRAY[0..3] OF REAL	[4(0.0)]		Minimum pulse width
Delay	ARRAY[0..3] OF REAL	[4(0.0)]		ON-delay time
Error_TimeProportionalOut	ARRAY[0..3] OF BOOL	[4(False)]		Error in TimeProportionalOut instruction
LimitAlarm_REAL_instance	LimitAlarm_REAL			
LimitAlarmDvStbySeq_REAL_instance	LimitAlarmDvStbySeq_REAL			
PIDAT_instance	PIDAT			
TimeProportionalOutput_instance	TimeProportionalOut			

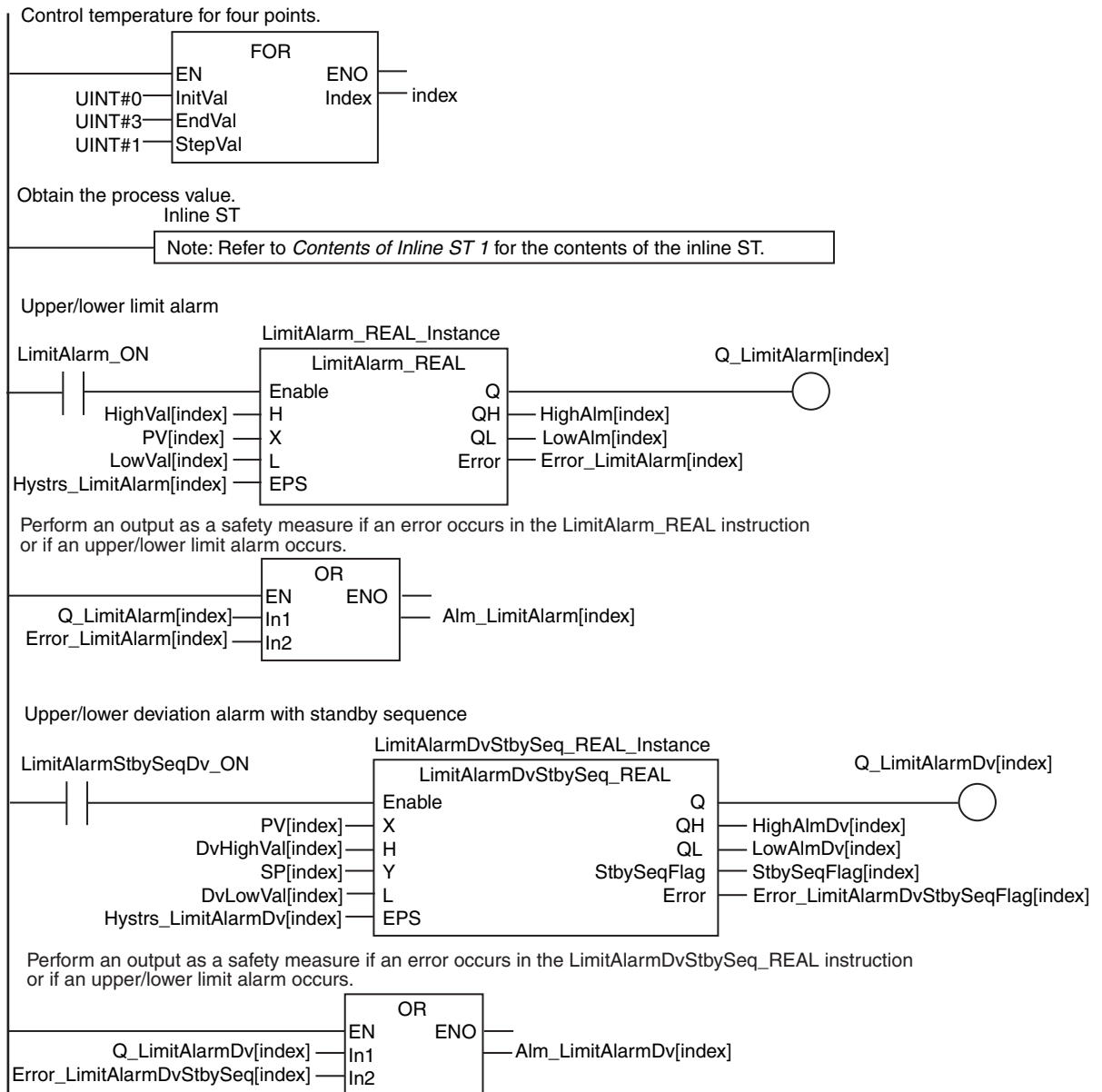

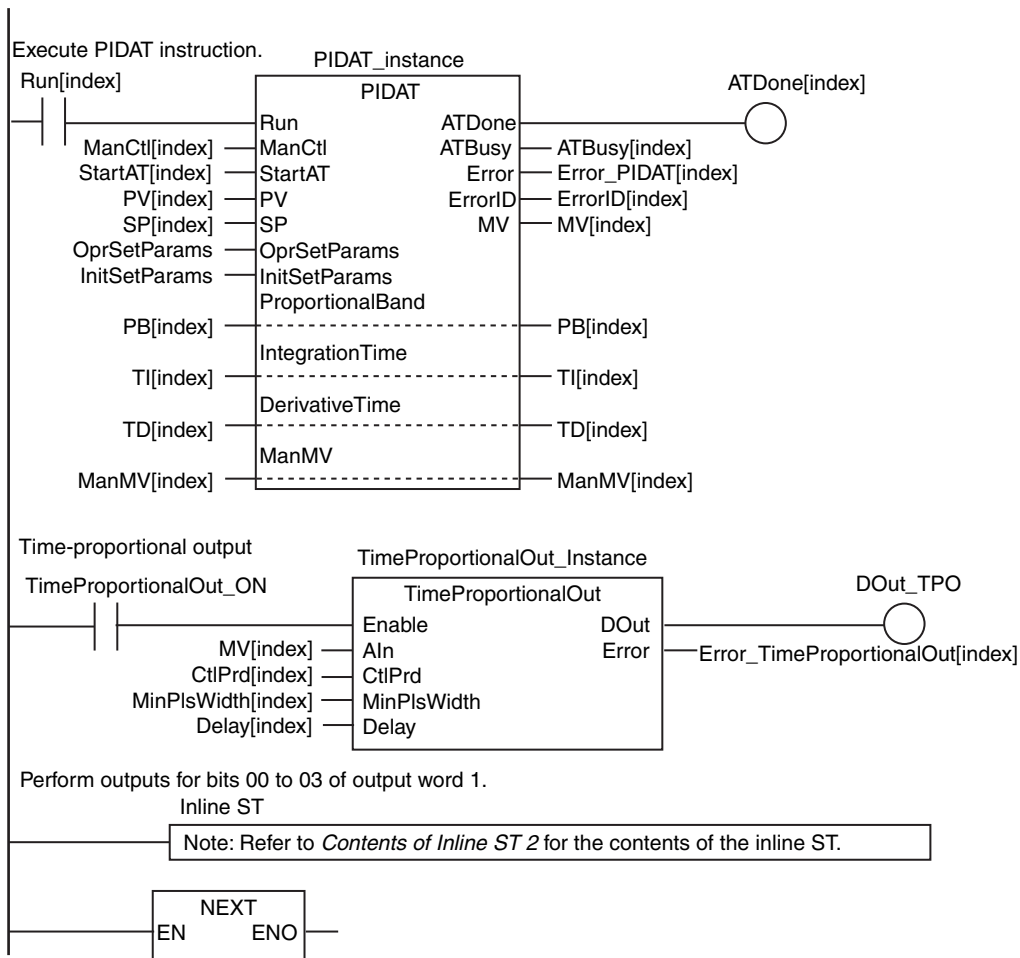

● Contents of Inline ST 1

```
// Get values of inputs 1 to 4.
CASE index OF
  INT#0:
    AI := AI1;
  INT#1:
    AI := AI2;
  INT#2:
    AI := AI3;
  ELSE
    AI := AI4;
END_CASE;

// Convert PV AI to real number.
PV[index] := INT_TO_REAL(AI) / REAL#10.0;
// CJ1W-PH41U output is ten times the process value, so divide by 10.0.
```

● Contents of Inline ST 2

```
// Perform outputs for bits 00 to 03 of output word 1.
CASE index OF
  INT#0:
    DO1 := DOut_TPO;
  INT#1:
    DO2 := DOut_TPO;
  INT#2:
    DO3 := DOut_TPO;
  ELSE
    DO4 := DOut_TPO;
END_CASE;
```

ST

Name	Data type	Default	Retain	Comment
index	UINT	0		Loop index
LimitAlarm_ON	BOOL	True		Execution of Upper/Lower Limit Alarm instruction
LimitAlarmDvStbySeq_ON	BOOL	True		Execution of Upper/Lower Deviation Alarm with Standby Sequence instruction
TimeProportionalOutput_ON	BOOL	True		Execution of Time-proportional Output instruction
AI	INT	0		Present value
PV	ARRAY[0..3] OF REAL	0.0		Process value
SP	ARRAY[0..3] OF REAL	[4(100)]		Set point
DOut_TPO	BOOL	False		Time-proportional output
HighVal	ARRAY[0..3] OF REAL	[4(200)]		Upper limit set value of upper/lower limit alarm
LowVal	ARRAY[0..3] OF REAL	[4(0.0)]		Lower limit set value of upper/lower limit alarm
Hysters_LimitAlarm	ARRAY[0..3] OF REAL	[4(5)]		Hysteresis of upper/lower limit alarm
Q_LimitAlarm	ARRAY[0..3] OF BOOL	[4(False)]		Upper/lower limit alarm output
HighAlm	ARRAY[0..3] OF BOOL	[4(False)]		Upper limit alarm
LowAlm	ARRAY[0..3] OF BOOL	[4(False)]		Lower limit alarm
Error_LimitAlarm	ARRAY[0..3] OF BOOL	[4(False)]		Error in LimitAlarm_REAL instruction
Alm_LimitAlarm	ARRAY[0..3] OF BOOL	[4(False)]		Output for safety measure for Upper/Lower Limit Alarm instruction
DvHighVal	ARRAY[0..3] OF REAL	[4(50)]		Upper deviation set value of upper/lower deviation alarm
DvLowVal	ARRAY[0..3] OF REAL	[4(50)]		Lower deviation set value of upper/lower deviation alarm
Q_LimitAlarmDv	ARRAY[0..3] OF BOOL	[4(False)]		Upper/lower deviation alarm output
HighAlmDv	ARRAY[0..3] OF BOOL	[4(False)]		Upper deviation alarm
LowAlmDv	ARRAY[0..3] OF BOOL	[4(False)]		Lower deviation alarm
StbySeqFlag	ARRAY[0..3] OF BOOL	[4(False)]		Standby Sequence Enabled Flag
Error_LimitAlarmDvStbySeq	ARRAY[0..3] OF BOOL	[4(False)]		Error in LimitAlarmDvStbySeq_REAL instruction
Hysters_LimitAlarmDv	ARRAY[0..3] OF REAL	[4(3)]		Hysteresis of upper/lower deviation alarm
Alm_LimitAlarmDv	ARRAY[0..3] OF BOOL	[4(False)]		Output for safety measure for Upper/Lower Deviation Alarm instruction
Run	ARRAY[0..3] OF BOOL	[4(False)]		Execution condition
ManCtl	ARRAY[0..3] OF BOOL	[4(False)]		Manual/auto control

Name	Data type	Default	Retain	Comment
StartAT	ARRAY[0..3] OF BOOL	[4(False)]		Autotuning execution condition
OprSetParams	_sOPR_SET_PARAMS	(MVLowlmt:=0.0, MVUpLmt:=100.0, ManResetVal:=0.0, MVTrackSw:=False, MVTrackVal:=0.0, StopMV:=0.0, ErrorMV:=0.0, Alpha:=0.65, ATCalcGain:=1.0, ATHystrs:=0.2)		Operation setting parameters
InitSetParams	_sINIT_SET_PARAMS	(SampTime:=T#100ms, RngLowmt:=-10.0, RngUpLmt:=1000.0, DirOpr:=False)		Initial setting parameters
PB	ARRAY[0..3] OF REAL	[4(10)]	✓	Proportional band
TI	ARRAY[0..3] OF TIME	[4(T#0S)]	✓	Integration time
TD	ARRAY[0..3] OF TIME	[4(T#0S)]	✓	Derivative time
ManMV	ARRAY[0..3] OF REAL	[4(0.0)]		Manual manipulated variable
ATDone	ARRAY[0..3] OF BOOL	[4(False)]		Autotuning normal completion
ATBusy	ARRAY[0..3] OF BOOL	[4(False)]		Autotuning busy
Error_PIDAT	ARRAY[0..3] OF BOOL	[4(False)]		Error in PIDAT instruction
ErrorID	ARRAY[0..3] OF WORD	[4(16#0)]		Error ID for PIDAT instruction
MV	ARRAY[0..3] OF REAL	[4(0.0)]		Manipulated variable
CtlPrd	ARRAY[0..3] OF TIME	[4(T#1s)]		Control period
MinPlsWidth	ARRAY[0..3] OF REAL	[4(0.0)]		Minimum pulse width
Delay	ARRAY[0..3] OF REAL	[4(0.0)]		ON-delay time
Error_TimeProportionalOut	ARRAY[0..3] OF BOOL	[4(False)]		Error in TimeProportionalOut instruction
LimitAlarm_REAL_instance	LimitAlarm_REAL			
LimitAlarmDvStbySeq_REAL_instance	LimitAlarmDvStbySeq_REAL			
PIDAT_instance	PIDAT			
TimeProportionalOut_instance	TimeProportionalOut			

```
// Control temperature for four points.
FOR index:=UINT#0 TO UINT#3 BY UINT#1 DO

    // Get values of inputs 1 to 4.
    CASE index OF
        INT#0:
            AI:=AI1;
        INT#1:
            AI:=AI2;
        INT#2:
            AI:=AI3;
        ELSE
            AI:=AI4;
    END_CASE;

    // Convert PV AI to real number.
    PV[index]:=INT_TO_REAL(AI)/REAL#10.0; // CJ1W-PH41U output is ten times the
    // process value, so divide by 10.0.

    // Upper/lower limit alarm
```

```

LimitAlarm_REAL_instance(
  Enable :=LimitAlarm_ON,
  H      :=HighVal[index],
  X      :=PV[index],
  L      :=LowVal[index],
  EPS    :=Hystrs_LimitAlarm[index],
  Q      =>Q_LimitAlarm[index],
  QH     =>HighAlm[index],
  QL     =>LowAlm[index],
  Error  =>Error_LimitAlarm[index]);

// Perform an output as a safety measure if an error occurs in the
// LimitAlarm_REAL instruction or if an upper/lower limit alarm occurs.
Alm_LimitAlarm[index]:=Q_LimitAlarm[index] OR Error_LimitAlarm[index];

// Upper/lower deviation alarm with standby sequence
LimitAlarmDvStbySeq_REAL_instance(
  Enable      :=LimitAlarmDvStbySeq_ON,
  X           :=PV[index],
  H           :=DvHighVal[index],
  Y           :=SP[index],
  L           :=DvLowVal[index],
  EPS        :=Hystrs_LimitAlarmDv[index],
  Q           =>Q_LimitAlarmDv[index],
  QH          =>HighAlmDv[index],
  QL          =>LowAlmDv[index],
  StbySeqFlag =>StbySeqFlag[index],
  Error       =>Error_LimitAlarmDvStbySeq[index]);

// Perform an output as a safety measure if an error occurs in the
// LimitAlarmDvStbySeq_REAL instruction
// or if an upper/lower limit alarm occurs.
Alm_LimitAlarmDv[index]:=Q_LimitAlarmDv[index] OR
Error_LimitAlarmDvStbySeq[index];

// Execute PIDAT instruction.
PIDAT_instance(
  Run           :=Run[index],
  ManCtl        :=ManCtl[index],
  StartAT       :=StartAT[index],
  PV            :=PV[index],
  SP            :=SP[index],
  OprSetParams  :=OprSetParams,
  InitSetParams :=InitSetParams,
  ProportionalBand:=PB[index],
  IntegrationTime :=TI[index],
  DerivativeTime :=TD[index],
  ManMV         :=ManMV[index],
  ATDone        =>ATDone[index],
  ATBusy        =>ATBusy[index],
  Error         =>Error_PIDAT[index],
  ErrorID       =>ErrorID[index],
  MV            =>MV[index]);

// Time-proportional output
TimeProportionalOut_instance(
  Enable      :=TimeProportionalOut_ON,
  AIn        :=MV[index],
  CtlPrd     :=CtlPrd[index],
  MinPlsWidth :=MinPlsWidth[index],
  Delay      :=Delay[index],
  DOut       =>DOut_TPO,
  Error      =>Error_TimeProportionalOut[index]);

// Perform outputs for bits 00 to 03 of output word 1.

```

```
CASE index OF
  INT#0:
    DO1:=DOut_TPO;
  INT#1:
    DO2:=DOut_TPO;
  INT#2:
    DO3:=DOut_TPO;
  ELSE
    DO4:=DOut_TPO;
END_CASE;

END_FOR;
```

ScaleTrans

The ScaleTrans instruction converts input values from an input range to an output range.

Instruction	Name	FB/FUN	Graphic expression	ST expression
ScaleTrans	Scale Transformation	FUN		Out :=ScaleTrans(ScIn,X0,Y0,X1,Y1, ScOfs);

Variables

Name	Meaning	I/O	Description	Valid range	Unit	Default
ScIn	Input value	Input	Value to scale	Depends on data type.	---	*
X0	Input range lower limit		Lower limit of input range			0
Y0	Output range lower limit		Lower limit of output range			
X1	Input range upper limit		Upper limit of input range			
Y1	Output range upper limit		Upper limit of output range			
ScOfs	Offset		Offset for output value			
Out	Output Value	Output	Value after scale transformation	---	---	

* If you omit the input parameter, the default value is not applied. A building error will occur.

	Boolean	Bit strings					Integers							Real numbers		Times, durations, dates, and text strings				
	BOOL	BYTE	WORD	DWORD	LWORD	USINT	UINT	UDINT	ULINT	SINT	INT	DINT	LINT	REAL	LREAL	TIME	DATE	TOD	DT	STRING
ScIn														OK	OK					
X0														OK	OK					
X1														OK	OK					
Y0														OK	OK					
Y1														OK	OK					
ScOfs														OK	OK					
Out														OK	OK					

Function

The Scale Trans instruction scales the value of input value *ScIn* from an input range to an output range.

The input range is specified with input range lower limit *X0* and input range upper limit *X1*. The output range is specified with output range lower limit *Y0* and output range upper limit *Y1*.

The value of offset *ScOfs* is added to the value that was scaled to the output range and the result is output as output value *Out*. *ScOfs* is used, for example, to correct for error in temperature control.

The following conversion is used.

$$\text{Out} = \frac{Y1 - Y0}{X1 - X0} (\text{ScIn} - X0) + Y0 + \text{ScOfs}$$

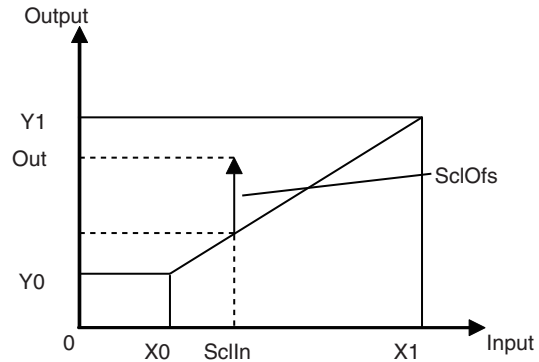

Notation Example

The following notation example scales an input value of 2,500 from an input range of 0 to 4,000 to an output range of 0% to 100%. An offset of 5% is added to the output value.

The following values are used: *ScIn* = REAL#2500, *X0* = REAL#0, *X1* = REAL#4000, *Y0* = REAL#0, *Y1* = REAL#100, and *ScOfs* = REAL#5.

The value of *Out* will be REAL#67.5.

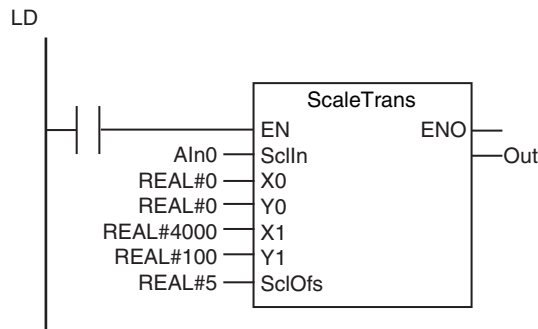

ST

```
Out := ScaleTrans(Aln0, REAL#0, REAL#0, REAL#4000,
                 REAL#100, REAL#5);
```

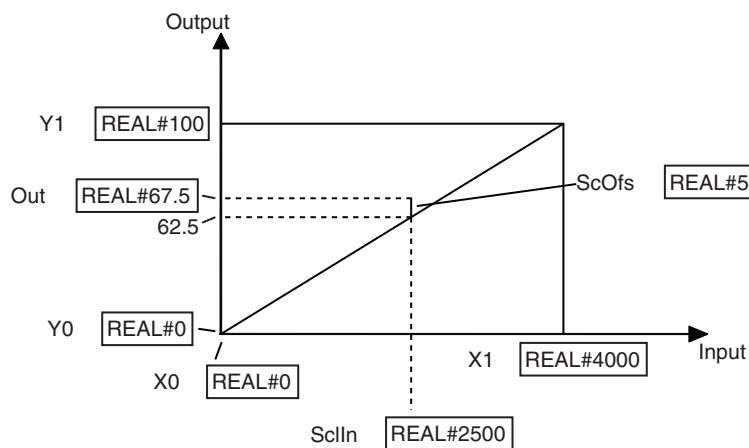

An input value of 2,500 is scaled to 62.5 for an input range of 0 to 4,000 and an output range of 0 to 100. When an offset of 5 is added, *Out* becomes REAL#67.5.

Additional Information

- When scaling $ScIn$ to the ranges of the values of PV and SP of the PIDAT instruction, pass the following parameters to $Y0$ and $Y1$.

Variable	Parameter
Y0	InitSetParams.RngLowLmt (input range lower limit of the PIDAT instruction)
Y1	InitSetParams.RngUpLmt (input range upper limit of the PIDAT instruction)

- Settings are also possible with $X1 < X0$ and $Y1 < Y0$.

Precautions for Correct Use



Version Information

A CPU Unit with unit version 1.05 or later and Sysmac Studio version 1.06 or higher are required to use this instruction.

AC_StepProgram

The AC_StepProgram instruction calculates the present set point and the predicted set point every task period according to the specified program pattern.

Instruction	Name	FB/ FUN	Graphic expression	ST expression
AC_Step Program	Step Program	FB		AC_StepProgram_instance(Enable, Hold, Advance, PV, IntegrationTime, Alpha, Option, ProgramPattern, Done, Busy, Error, ErrorID, Wait, StepNo, PresentSP, PredictSP, TimeInfo);

Variables

Name	Meaning	I/O	Description	Valid range	Unit	Default			
Enable	Enable	Input	TRUE: Execute FALSE: Stop	Depends on data type.	---	FALSE			
Hold	Hold		TRUE: Hold FALSE: Do not hold						
Advance	Advance		The number of the step that is executed is incremented each time this variable changes to TRUE.						
PV	Process value		Measured value (process value)*1				0		
Integration-Time	Integration time		Integration time*2				T#0.0000s to T#10000.0000s*3	s	T#0s
Alpha	2-PID parameter α		2-PID parameter α *4				0.00 to 1.00	---	0
Option	Option		Option*5				---	---	---
Program-Pattern[] array	Program pattern	In-out	Program pattern	---	---	---			
Wait	Waiting	Output	TRUE: Waiting FALSE: Not waiting	Depends on data type.	---	---			
StepNo	Present step number		The number of the current step	0 to 99					
PresentSP	Present set point		The calculated present set point	Depends on data type.					
PredictSP	Predicted set point		The calculated predicted set point	Depends on data type.					
TimeInfo	Clock information		Clock information to monitor the progress of the instruction	---					

*1 It is the same as *PV* in the PIDAT instruction. Refer to *PV (Process Value)* on page 2-776 for details.

*2 It is the same as *IntegrationTime* in the PIDAT instruction. Refer to *IntegrationTime (Integration Time)* on page 2-776 for details.

*3 Digits below 0.0001 s are truncated.

*4 It is the same as *OprSetParams.Alpha* in the PIDAT instruction. Refer to *Alpha (2-PID Parameter α)* on page 2-777 for details.

*5 Refer to *Structure Specifications* on page 2-775 for details.

	Boolean	Bit strings				Integers								Real numbers		Times, durations, dates, and text strings				
	BOOL	BYTE	WORD	DWORD	LWORD	USINT	UINT	UDINT	ULINT	SINT	INT	DINT	LINT	REAL	LREAL	TIME	DATE	TOD	DT	STRING
Enable	OK																			
Hold	OK																			
Advance	OK																			
PV														OK						
Integration-Time																OK				
Alpha														OK						
Option	Refer to <i>Function</i> for details on the structure <code>_sAC_STEP_OPTION</code> .																			
Program-Pattern[] array*1*2*3	Refer to <i>Function</i> for details on the structure <code>_sAC_STEP_DATA</code> . Specify an array.																			
Wait	OK																			
StepNo						OK														
PresentSP														OK						
PredictSP														OK						
TimeInfo	Refer to <i>Function</i> for details on the structure <code>_sAC_STEP_TIME</code> .																			

*1 The array can have a maximum of 100 elements.

*2 This is a one-dimensional array. If an array with more than one dimension is specified, a building error will occur.

*3 The first array element number is 0. If a number other than 0 is specified for the first array element, a building error will occur.

Function

You use the `AC_StepProgram` instruction together with the `PIDAT` instruction to calculate present set point *PresentSP* and predicted set point *PredictSP* every task period when you perform manipulated variable control for a temperature controller or other controller.

The present set point is the set point in the present task period. The predicted set point is arrived at by applying delay compensation for 2-PID control to the present set point. By passing predicted set point *PredictSP* to set point *SP* of the `PIDAT` instruction, you can improve the tracking characteristic of programmed control with the `PIDAT` instruction.

PresentSP (Present Set Point)

Present set point *PresentSP* is the set point in the present task period. For example, assume that the user sets the set points for 0, 10, 40, and 60 minutes after the start of control as shown below. Also assume that the current time is 30 minutes after the start of control. The AC_StepProgram instruction performs linear interpolation of the set points for 10 minutes and 40 minutes after the start of control and calculates *PresentSP*.

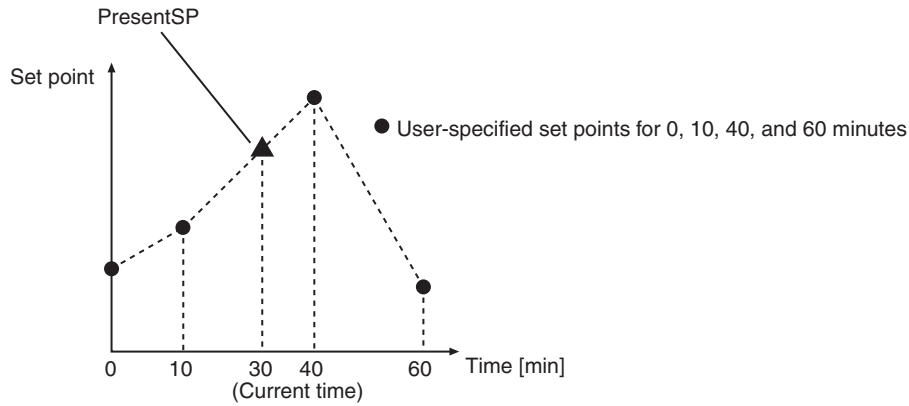

PredictSP (Predicted Set Point)

Predicted set point *PredictSP* is arrived at by applying delay compensation for 2-PID control to present set point *PresentSP*. If *PresentSP* is passed to *SP* in the PIDAT instruction without compensation, *PV* in the PIDAT instruction will not match the set point. This is illustrated in the following figure.

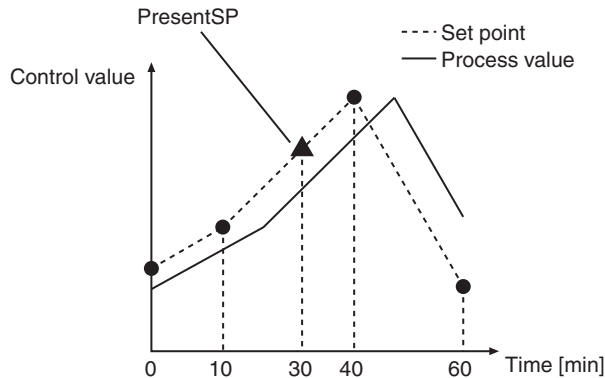

The set point that can be compensated for delay is given by *PredictSP*. The AC_StepProgram instruction calculates *PredictSP* based on integration time *IntegrationTime* and 2-PID parameter α *Alpha*. By passing *PredictSP* to *SP* of the PIDAT instruction, the tracking characteristic of programmed control with the PIDAT instruction is improved.

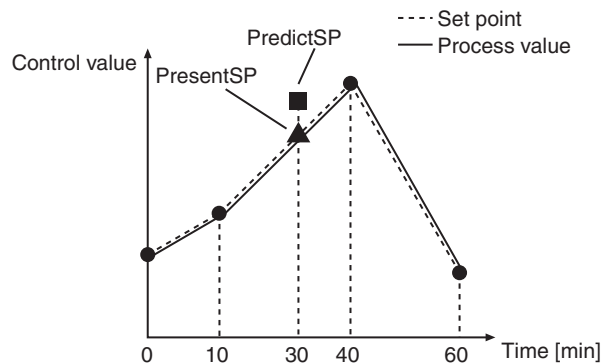

Structure Specifications

The data type of *Option* is structure `_sAC_STEP_OPTION`. The specifications are as follows:

Name	Meaning	Description	Data type	Valid range	Unit	Default
Option	Option	Option	<code>_sAC_STEP_OPTION</code>	---		---
StartAtPV	Start at PV	TRUE: Enable starting at PV FALSE: Disable starting at PV	BOOL	Depends on data type.		FALSE
StartStepNo	Start step number	The step number from which to start processing	USINT	0 to 99	---	0
EndStepNo	End step number	The step number from which to end processing*1	USINT			
Reserved	Reserved.	Reserved.	ARRAY[0..31] OF BYTE	Depends on data type.		All 32 elements contain 0.

*1 A setting of 0 treats the highest element number in *ProgramPattern[]* as the end step number.

The data type of the elements of program pattern *ProgramPattern[]* is structure `_sAC_STEP_DATA`. The specifications are as follows:

Name	Meaning	Description	Data type	Valid range	Unit	Default
Program Pattern	Program pattern	Program pattern	<code>_sAC_STEP_DATA</code>	---		---
ReachSP	Target set point	The target step point for the step	REAL	Depends on data type.		0
TimeWidth	Time width	The time width of the step*1	TIME		s	T#0s
WaitWidth	Wait width	The wait width of the step*2	REAL		---	0
WaitTime Limit	Wait time upper limit	The upper limit of the wait width of the step*1*3	TIME		s	T#0s

*1 The resolution is one task period.

*2 A setting of 0 or less is treated as 0.

*3 A setting of 0 or less is treated as T#0s.

The data type of clock information *TimeInfo* is structure `_sAC_STEP_TIME`. The specifications are as follows:

Name	Meaning	Description	Data type	Valid range	Unit	Default
TimeInfo	Clock information	Clock information	<code>_sAC_STEP_TIME</code>	---	---	---
ProgramTime	Program time	The total of <i>TimeWidth</i> from step 0 to <i>End-StepNo</i> .	TIME	Non-negative value	s	T#0s
ElapseTime	Elapsed time	The elapsed time from when instruction execution started*1	TIME			
Progress Time	Progress time	The elapsed time from when instruction execution started*2	TIME			
LeftTime	Remaining time	The time from the present until all processing is completed*2	TIME			
StepProgress-Time	Step progress time	The elapsed time from the start of the current step*2	TIME			
StepLeftTime	Step remaining time	The time from the present until all processing is completed for the current step*2	TIME			

*1 Includes the wait time. Does not include the hold time.

*2 This value does not include the wait time and hold time.

Meanings of Variables

The meanings of the variables that are used in this instruction are described below.

● **Enable (Enable)**

This is the execution condition for the instruction.

Instruction execution starts when *Enable* changes to TRUE. Instruction execution stops when *Enable* changes to FALSE.

● **Hold (Hold)**

This is the execution flag for holding.

Holding is performed when *Hold* changes to TRUE.

Details on holding are provided later.

● **Advance (Advance)**

If the value changes to TRUE during instruction execution, processing moves to the next step.

Details on advancing are provided later.

● **PV (Process Value)**

This variable gives the process value of the controlled system. It is the same as *PV* in the PIDAT instruction.

● **IntegrationTime (Integration Time)**

This variable is the same as *IntegrationTime* in the PIDAT instruction.

Input the value of *IntegrationTime* or the *IntegrationTime* variable in the PIDAT instruction or PIDAT_HeatCool instruction.

- **Alpha (2-PID Parameter α)**

This variable is the same as *OprSetParams.Alpha* in the PIDAT instruction.

Input the value of *OprSetParams.Alpha* or the *OprSetParams.Alpha* variable in the PIDAT instruction or PIDAT_HeatCool instruction.

- **StartAtPV (Start at PV)**

This variable is the execution flag for starting at the process value.

Starting at the process value is performed when *StartAtPV* is TRUE.

Details on starting at the process value are provided later.

- **StartStepNo (Start Step Number) and EndStepNo (End Step Number)**

These variables give the number for the step from which to start processing and the number of the step to end processing of the steps in the program pattern.

A setting of 0 for *EndStepNo* treats the highest element number in *ProgramPattern[]* as the end step number.

Details on program patterns and steps are provided later.

- **ReachSP (Target Set Point)**

This variable gives the set point that should be reached at the end of the step in the program pattern.

Details on program patterns and steps are provided later.

- **TimeWidth (Time Width)**

This variable gives the time width for the step in the program pattern.

Details on program patterns and steps are provided later.

- **WaitWidth (Wait Width)**

This variable gives the threshold for performing waiting in the step in the program pattern.

Details on waiting are provided later.

- **WaitTimeLimit (Wait Time Limit)**

This variable gives the upper limit of the wait time for waiting in the step in the program pattern.

If the value of *WaitTimeLimit* is T#0, the upper limit of the wait time is infinity.

Details on waiting are provided later.

- **Wait (Waiting)**

This variable is a flag that indicates if waiting is in progress.

If *Wait* is TRUE, waiting is in progress.

Details on waiting are provided later.

- **StepNo (Present Step Number)**

This variable gives the number of the current step.

Details on program patterns and steps are provided later.

- ***PresentSP* (Present Set Point)**

This variable gives the calculated present set point.

- ***PredictSP* (Predicted Set Point)**

This variable gives the calculated predicted set point.

- ***ProgramTime* (Program Time)**

This variable gives the total of *TimeWidth* from step 0 to *EndStepNo* in the program pattern. Details on program patterns and steps are provided later.

- ***ElapseTime* (Elapsed Time)**

This variable gives the elapsed time from when instruction execution started. This value includes the wait time but not the hold time.

Details on waiting and holding are provided later.

- ***ProgressTime* (Progress Time)**

This variable gives the elapsed time from when instruction execution started. This value does not include the wait time and hold time.

Details on waiting and holding are provided later.

- ***LeftTime* (Remaining Time)**

This variable gives the time from the present until all processing is completed. This value does not include the wait time and hold time.

Details on waiting and holding are provided later.

- ***StepProgressTime* (Step Progress Time)**

This variable gives the elapsed time from the start of the current step in the program pattern. This value does not include the wait time and hold time.

Details on program patterns, steps, waiting, and holding are provided later.

- ***StepLeftTime* (Step Remaining Time)**

This variable gives the time from the present until all processing is completed for the current step in the program pattern. This value does not include the wait time and hold time.

Details on program patterns, steps, waiting, and holding are provided later.

Program Pattern

The program pattern divides the processing from the start to end of execution of the instruction into steps and chronologically gives the target set point and time width for each step. The program pattern is expressed in the *ProgramPattern[]* array, which has elements with a data type of *_sAC_STEP_DATA*. Each element of *ProgramPattern[]* corresponds to one step.

An example of a program pattern is provided below. If the values of the *ReachSP* and *TimeWidth* elements of *ProgramPattern[]* are as given in the following table, the relation between time and the set points after instruction execution is started is shown in the following figure.

	ProgramPattern[] element number							
	0	1	2	3	4	5	6	7
Step number	0	1	2	3	4	5	6	7
Value of <i>ReachSP</i>	30	100	120	200	200	80	80	0
Value of <i>TimeWidth</i>	T#0s	T#10m	T#15m	T#0s	T#15m	T#4m	T#5m	T#0s

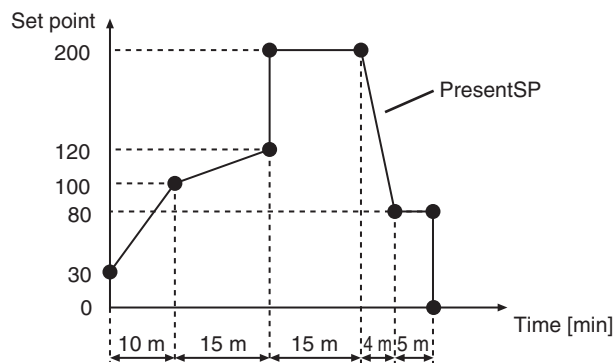

Linear interpolation is performed for the set points for the steps and the value of *PresentSP* is calculated for each point. The solid line in the figure represents *PresentSP*. For each task period, the value of *PresentSP* at that point is output.

● Relation between the Value of *TimeWidth* and the Time Width of the Step

The following table shows the relation between the value of *TimeWidth* and the time width of the step.

Value of <i>TimeWidth</i>	Step number	Time width of the step
T#0s	0	Treated as T#0s.
	Not 0	Treated as one task period.
Positive	---	The value of <i>TimeWidth</i> is the time width of the step.
Negative	---	Treated as one task period.

● Operation for Step Time Width That Is Less Than One Task Period

The resolution of the step time width is one task period. The following table describes the operation for a step time width that is less than one task period.

Step number	Time width of the step	Operation
0	T#0s	The value of <i>ReachSP</i> for step 0 is the initial value for <i>PresentSP</i> . Actual processing starts from step 1.
	Not T#0s	Processing for the current step is executed for only one task period and then processing moves to the next step.
Not 0	---	

Start Step Number *StartStepNo* and End Step Number *EndStepNo*

You can set any steps in the program pattern as the start step and the end step for processing. Set the number of the start step in *StartStepNo* and the number of the end step in *EndStepNo*.

For example, if you set *StartStepNo* to 3 and *EndStepNo* to 6 when you execute the instruction, processing is performed from step 3 through step 6.

● Changing the Value of *StartStepNo* or *EndStepNo* during Instruction Execution

You can change the values of *StartStepNo* and *EndStepNo* during execution of the instruction. The operation that occurs if you change these values is described in the following table.

Variable	New step number	Operation
<i>StartStepNo</i>	---	Processing will start from the beginning of the step specified by the new <i>StartStepNo</i> .
<i>EndStepNo</i>	Changing to a step number that is equal to or higher than the current step number	Progressing will end when the step specified by the new <i>EndStepNo</i> is completed.
	Changing to a step number that is lower than the current step number	Processing ends as soon as the end step number is changed. The value of <i>Done</i> changes to TRUE.

Waiting

Due to delays in the controlled system, the value of *PV* may not reach the value of *ReachSP* with *TimeWidth* for the current step. Waiting can be applied to continue processing the current step even if the time width specified in *TimeWidth* is exceeded.

The following variables in *ProgramPattern[]* are related to waiting: wait width *WaitWidth*, wait time upper limit *WaitTimeLimit*, and waiting *Wait*.

● Condition for Waiting

Waiting occurs if the difference between *ReachSP* and *PV* exceeds *WaitWidth* after the end time for the current step.

● End of Waiting

If the difference between *ReachSP* and *PV* becomes equal to or less than *WaitWidth* before *WaitTimeLimit* is reached after the start of waiting, waiting ends at that time and processing moves to the next step.

If the difference between *ReachSP* and *PV* does not become equal to or less than *WaitWidth* before *WaitTimeLimit* is reached after the start of waiting, waiting ends when the time set for *WaitTimeLimit* expires and processing moves to the next step. However, if the value of *WaitTimeLimit* is T#0, the upper limit of the wait time is infinity. Therefore, waiting occurs without a time limit until the difference between *ReachSP* and *PV* becomes less than or equal to *WaitWidth*.

● Monitoring Waiting

You can monitor waiting with the value of *Wait*. If processing is currently waiting, the value of *Wait* is TRUE. If processing is not currently waiting, the value of *Wait* is FALSE.

● **Timing during Waiting**

The operations of the time-related variables during waiting are described in the following table.

Name	Operation
ElapsedTime	Continues timing.
ProgressTime	Stops timing and retains the value from when waiting started. Starts timing again from the retained value when waiting ends.
LeftTime	
StepProgressTime	Goes to the value of <i>TimeWidth</i> for the current step and then retains that value.
StepLeftTime	Goes to 0 and then retains that value.

● **PresentSP and PredictSP during Waiting**

During waiting, both *PresentSP* and *PredictSP* retain the value of *ReachSP*.

The following figure provides a graph of *PV* when the difference between *ReachSP* and *PV* becomes equal to or less than *WaitWidth* within the time set for *WaitTimeLimit*. The difference between *ReachSP* and *PV* still exceeds *WaitWidth* after the end time for the current step, so waiting occurs. When the difference between *ReachSP* and *PV* becomes less than or equal to *WaitWidth*, processing moves to the next step.

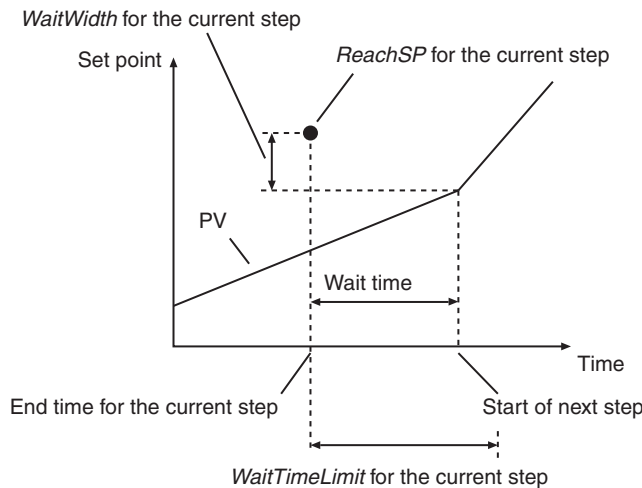

The following figure provides a graph of *PV* when the difference between *ReachSP* and *PV* does not become equal to or less than *WaitWidth* within the time set for *WaitTimeLimit*. Processing moves to the next step after the time that is set for *WaitTimeLimit* expires.

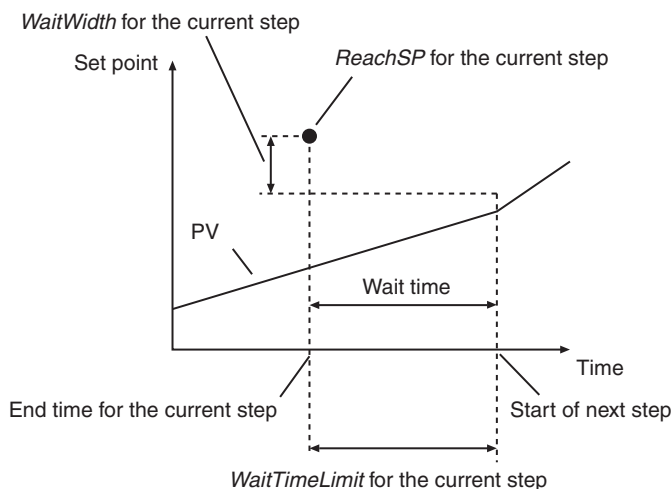

Holding

Processing for the current step is held unconditionally whenever the value *Hold* is TRUE. While processing is held, timing is stopped for all time-related variables.

Timing is started again for these time-related variables when the value of *Hold* changes to FALSE.

● Timing while Holding

The operations of the time-related variables while processing is held are described in the following table.

Name	Operation
ElapseTime	Stops timing and retains the value from when holding started. Starts timing again from the retained value when holding ends.
ProgressTime	
LeftTime	
StepProgressTime	
StepLeftTime	

● *PresentSP* and *PredictSP* while Holding

While processing is held, *PresentSP* retains the value from when holding started.

While processing is held, *PredictSP* has the same value as *PresentSP*.

● Holding during Waiting

If you hold processing during waiting, waiting is ended. Therefore, the value of *Wait* changes to FALSE. When holding is ended, the conditions for waiting are judged again.

Start at PV

You can start processing when the value of *PV* and the value of *PresentSP* are equal. If the value of *StartAtPV* is TRUE when *Enable* changes to TRUE, the start at PV operation is used.

Processing is performed as follows for the start at PV operation.

- 1** The value of *PV* is obtained.
- 2** A search is made from step 0 to the last step for the time when the value of *PV* first equals the value of *PresentSP*.
If the value of *PresentSP* increases from the start of step 0, the search is made only until just before the value of *PresentSP* starts to decrease. In the same way, if the value of *PresentSP* decreases from the start of step 0, the search is made only until just before the value of *PresentSP* starts to increase.
- 3** Processing is started from the point that was found in the above search.

If there is no time in the search range where *PV* and *PresentSP* have the same value, processing is started from step 0.

An example of the start at PV operation is provided below. The following table gives the contents of *ProgramPattern[]*.

	ProgramPattern[] element number							
	0	1	2	3	4	5	6	7
Step number	0	1	2	3	4	5	6	7
Value of <i>ReachSP</i>	30	100	120	200	200	80	80	0
Value of <i>TimeWidth</i>	T#0s	T#10m	T#15m	T#0s	T#15m	T#4m	T#5m	T#0s

In this example, the value of *PresentSP* increases from the value for step 0. Therefore, a search is made only for 40 minutes after the start of processing, i.e., the point where the value of *PresentSP* starts to decrease.

Assume that the value of *PV* at the start of instruction execution is 110. In this case, processing starts as shown in the following figure where *PresentSP* equals 110.

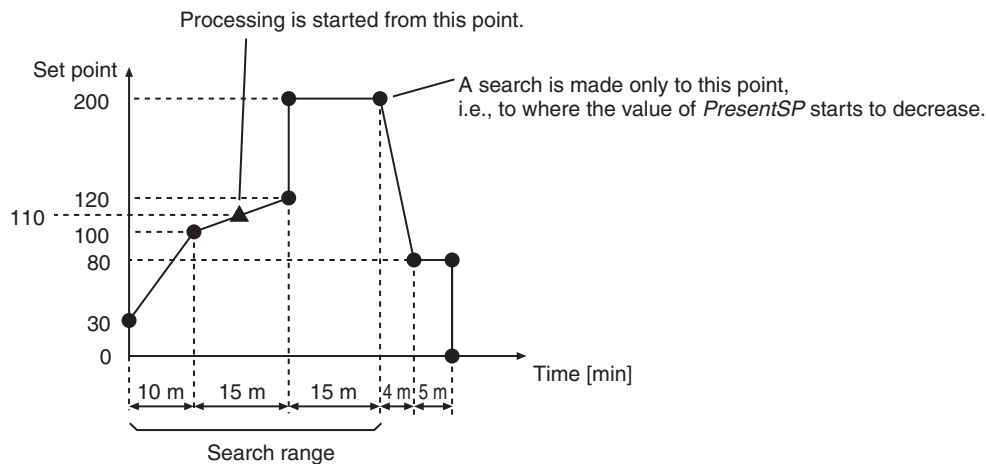

● **Timing for Start at PV Operation**

The operations of the time-related variables for the start at PV operation are described in the following table.

Name	Operation
ElapsedTime	Contains 0.
ProgressTime	Gives the time from step 0 to the point that was found in the search.
LeftTime	Gives the time from the present to the end of <i>EndStepNo</i> .
StepProgressTime	Gives the time from the beginning of the current step to the point that was found in the search.
StepLeftTime	Gives the time from the present until all processing is completed for the current step.

● **Changing the Value of *StartAtPV* during Instruction Execution**

Any changes to the value of *StartAtPV* during execution of the instruction are ignored.

Advancing

If the value of *Advance* changes to TRUE during instruction execution, processing moves to the beginning of the next step.

● Timing for Advancing

The operations of the time-related variables when processing is advanced to the next step are described in the following table.

Name	Operation
ElapseTime	Continues timing.
ProgressTime	Gives the total of <i>TimeWidth</i> from step 0 until the current step.
LeftTime	Gives the time from the next step to the end of <i>EndStepNo</i> .
StepProgressTime	Contains 0 because processing moves to the start of the next step.
StepLeftTime	Gives the value of <i>TimeWidth</i> for the next step.

● Changing the Value of *StartStepNo* and Advancing Processing at the Same Time

If you change the values of *StartStepNo* and *Advance* to TRUE at the same time, changing the value of *StartStepNo* is given priority. Therefore, processing moves to the start of *StartStepNo*.

Changing the Program Pattern during Instruction Execution

You can change the contents of *ProgramPattern[]* during execution of the instruction. If you change the contents of *ProgramPattern[]*, the *PresentSP* is calculated again. Processing is started again from the time in *StepProgressTime* at the step that was in execution before the program pattern was changed. You can also change the contents of previous steps.

For example, assume that the contents of *ProgramPattern[]* are changed during execution of step 4. Also assume that the previous value of *StepProgressTime* was T#5m. After you change the program pattern, processing will start again at a value of T#5m for *StepProgressTime* in step 4.

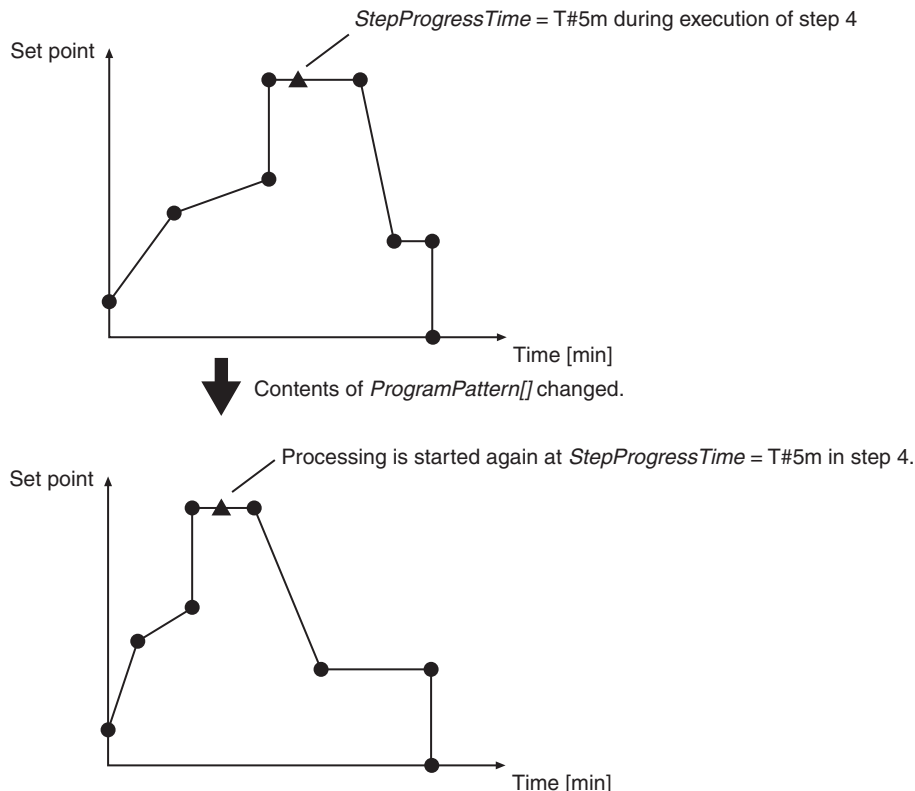

If the value of *TimeWidth* for the step is smaller than the value of *StepProgressTime*, processing is started again from the start of the next step.

● Timing for Changes in the Program Pattern during Instruction Execution

The operations of the time-related variables when the program pattern is changed during instruction execution are described in the following table.

Name	Operation
ProgramTime	Gives the total of <i>TimeWidth</i> from step 0 to <i>EndStepNo</i> after the change.
ElapsedTime	Continues timing.
ProgressTime	Gives the total of <i>StepProgressTime</i> and the total of <i>TimeWidth</i> from step 0 to one step before the current step after the change.
LeftTime	Gives the time from the present to the end of <i>EndStepNo</i> after the change.
StepProgressTime	Timing continues from the value before the change.
StepLeftTime	Gives the time from the present in the current step until all processing is completed for the current step after the change.

● **Changing the Program Pattern during Waiting**

If you change the program pattern during waiting, waiting judgement is performed again for the recalculated *PresentSP*.

However, if the value of *StepProgressTime* is larger than the value of *WaitTimeLimit* after the change, waiting is ended immediately and processing moves to the next step.

● **Changing the Program Pattern during Holding**

If you change the program pattern during holding, holding continues for the recalculated *PresentSP*.

Timing Charts

The following figure shows a timing chart for normal operation.

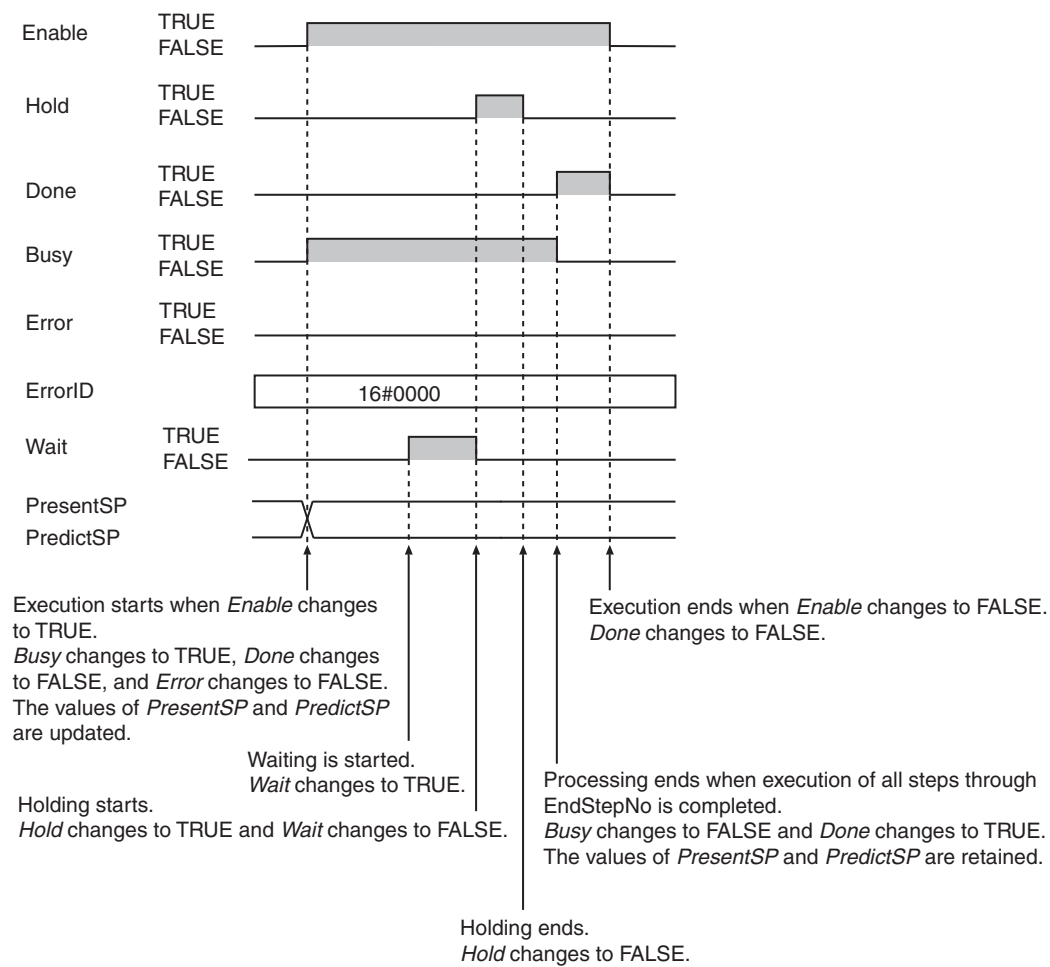

The following figure shows a timing chart for when an error occurs.

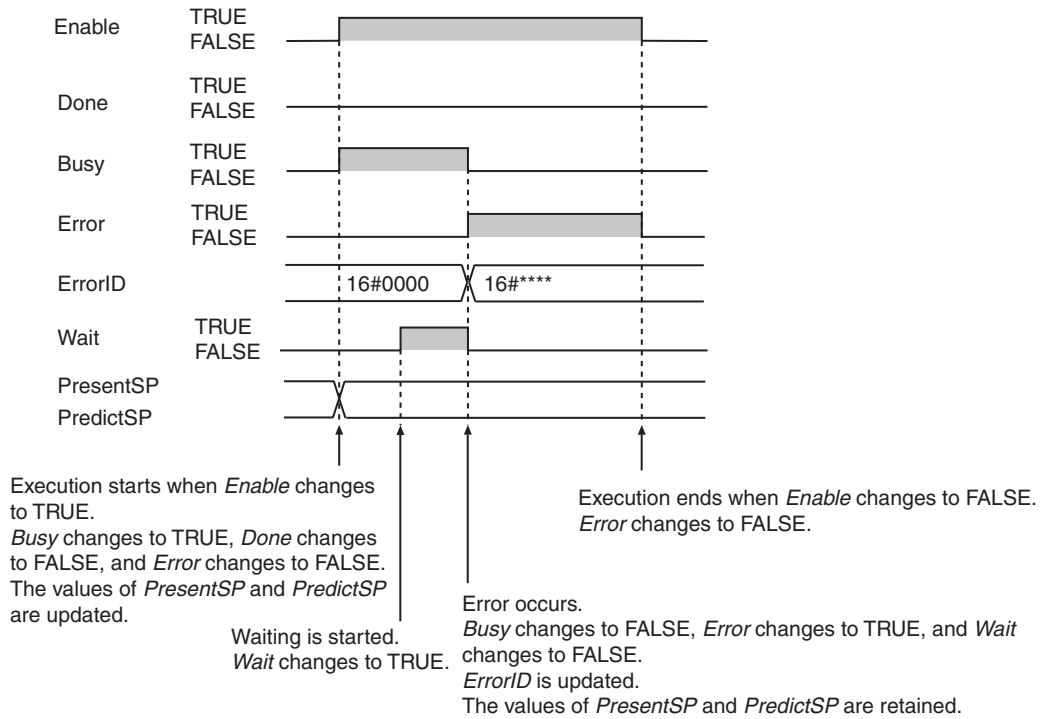

Precautions for Correct Use

- An error occurs in the following cases. *Error* will change to TRUE, and an error code is assigned to *ErrorID*.

Error	Value of <i>ErrorID</i>
The value of <i>IntegrationTime</i> , <i>Alpha</i> , <i>StartStepNo</i> , or <i>EndStepNo</i> is outside of the valid range.	16#0400
The final element number in the <i>ProgramPattern[]</i> array exceeded 99.	16#0416

Version Information

A CPU Unit with unit version 1.06 or later and Sysmac Studio version 1.07 or higher are required to use this instruction.

Sample Programming

This sample performs temperature control with the optimum PID parameters for each step in the AC_StepProgram instruction.

Processing

This sample performs the following two processes.

- It calculates the optimum PID parameters for each step.
- It controls temperature according to the program pattern.

Both of these processes are described below.

● Calculating Optimum PID Parameters for Each Step

Before temperature is controlled according to the program pattern, the optimum PID parameters for each step must be calculated. Autotuning with the PIDAT instruction is used to calculate the PID parameters.

The calculated PID parameters are stored in the *PIDbank[]* array of structures with the step numbers used as the array subscripts. The members of the elements of *PIDbank[]* give the proportional bands, integration times, and derivative times.

The processing procedure is as follows:

- 1** The user changes the value of *ACSP_Enable* to the AC_StepProgram instruction to TRUE.
The AC_StepProgram instruction is executed and the value of present step number *StepNo* changes to 0.
- 2** The user changes the value of execution condition *Run* to the PIDAT instruction to TRUE.
The PIDAT instruction is executed.
- 3** The user changes the value of autotuning execution condition *StartAT* to TRUE.
The value of *Hold* to the AC_StepProgram instruction changes to TRUE and holding is performed. Autotuning for the PIDAT instruction is executed and the optimum PID parameters are calculated for step 0.
- 4** Autotuning is completed.
The value of autotuning normal completion *ATDone* from the PIDAT instruction changes to TRUE.
The calculated PID parameters are stored in *PIDbank[0]*.
- 5** The user changes the value of *Hold* to the AC_StepProgram instruction to FALSE.
Holding for the AC_StepProgram instruction is canceled.
After a while, processing moves to the next step and the value of *StepNo* changes to 1.
- 6** The user repeats steps 3 to 5 for each step number.
The optimum PID parameters for all steps are stored in *PIDbank[]*.

● Controlling Temperature According to the Program Pattern

The optimum PID parameters for each step are used to control temperature according to the program pattern.

The processing procedure is as follows:

- 1** The user changes the value of *ACSP_Enable* to the *AC_StepProgram* instruction to TRUE.
The *AC_StepProgram* instruction is executed and the value of step number *StepNo* changes to 0.
- 2** The user changes the value of execution condition *Run* to the *PIDAT* instruction to TRUE.
The *PIDAT* instruction is executed.
- 3** For each task period, manipulated value *MV* from the *PIDAT* instruction is output.
- 4** The *TimeProportionalOut* instruction performs time-proportional output according to the value of *MV*.
- 5** After a while, processing moves to the next step.
- 6** Steps 3 to 5 are repeated through the end step.

Setup with the Sysmac Studio

To use the sample programming, you must use the Sysmac Studio to set the network configuration, I/O map, and data type definitions.

● Network Settings

The configuration of the network is given in the following table. A Slave Terminal with the following configuration is connected at EtherCAT node address 1. The device names that are given in the following table are used.

Unit number	Model number	Unit	Device name
0	NX-ECC201	EtherCAT Coupler Unit	E001
1	NX-TS2101	Temperature Input Unit	N1
2	NX-OD3121	Digital Output Unit	N2

● I/O Map

The following I/O map settings are used.

Position	Port	Description	R/W	Data type	Variable	Variable type
Unit1	Ch1 Measured Value REAL *1	Channel measured value (REAL)	R	REAL	N1_Ch1_Measured_Value_REAL	Global variable
Unit1	Ch2 Measured Value REAL *2	Channel measured value (REAL)	R	REAL	N1_Ch2_Measured_Value_REAL	Global variable
Unit2	Output Bit 00	Output bit 00	W	BOOL	N2_Output_Bit_00	Global variable
Unit2	Output Bit 01	Output bit 01	W	BOOL	N2_Output_Bit_01	Global variable
Unit2	Output Bit 02	Output bit 02	W	BOOL	N2_Output_Bit_02	Global variable
Unit2	Output Bit 03	Output bit 03	W	BOOL	N2_Output_Bit_03	Global variable

*1 You must add 0x6003:01 (Ch1 Measured Value REAL) to the I/O entries for the NX-TS2101 Temperature Input Unit.

*2 You must add 0x6003:02 (Ch2 Measured Value REAL) to the I/O entries for the NX-TS2101 Temperature Input Unit.

● Data Type Definitions

The structure *sPID_BANK* is defined as shown in the following table.

Structure	Name	Data type	Comment
▼	sPID_BANK	STRUCT	PID parameter structure
	PB	REAL	Proportional band
	TI	TIME	Integration time
	TD	TIME	Derivative time

LD

Internal Variables	Variable	Data type	Initial value	Comment
	ACSP_Enable	BOOL	FALSE	Enable for AC_StepProgram
	Hold	BOOL	FALSE	Hold
	Advance	BOOL	FALSE	Advance
	Option	_sAC_STEP_OPTION	(StartAtPV:=FALSE, StartStepNo:=0, EndStepNo:=7, Reserved:=[32(16#0)])	Option
	ProgramPattern	ARRAY[0..7] OF _sAC_STEP_DATA	[(ReachSP:=30.0, TimeWidth:=T#0s, WaitWidth:=3.0, WaitTimeLimit:=T#1m), (ReachSP:=100.0, TimeWidth:=T#10m, WaitWidth:=3.0, WaitTimeLimit:=T#1m), (ReachSP:=120.0, TimeWidth:=T#15m, WaitWidth:=3.0, WaitTimeLimit:=T#1m), (ReachSP:=150.0, TimeWidth:=T#0s, WaitWidth:=3.0, WaitTimeLimit:=T#1m), (ReachSP:=150.0, TimeWidth:=T#15m, WaitWidth:=3.0, WaitTimeLimit:=T#1m), (ReachSP:=80.0, TimeWidth:=T#4m, WaitWidth:=3.0, WaitTimeLimit:=T#1m), (ReachSP:=80.0, TimeWidth:=T#5m, WaitWidth:=3.0, WaitTimeLimit:=T#1m), (ReachSP:=10.0, TimeWidth:=T#0s, WaitWidth:=3.0, WaitTimeLimit:=T#1m)]	Program pattern
	ACSP_Busy	BOOL	FALSE	Execution of AC_StepProgram in progress
	ACSP_Error	BOOL	FALSE	AC_StepProgram error
	ACSP_ErrorID	WORD	WORD#16#0	AC_StepProgram error code
	Wait	BOOL	FALSE	Waiting
	StepNo	USINT	0	Present step number
	PresentSP	REAL	0.0	Present set point
	PredictSP	REAL	0.0	Predicted set point

Internal Variables	Variable	Data type	Initial value	Comment
	TimeInfo	_sAC_STEP_TIME	(ProgramTime:=T#0s, ElapseTime:=T#0s, ProgressTime:=T#0s, LeftTime:=T#0s, StepProgressTime:=T#0s, StepLeftTime:=T#0s)	Clock information
	ACSP_Done	BOOL	FALSE	AC_StepProgram completion
	Run	BOOL	FALSE	PIDAT instruction execution condition
	ManCtl	BOOL	FALSE	Manual/auto control
	StartAT	BOOL	FALSE	Autotuning execution condition
	OprSetParams	_sOPR_SET_PARAMS	(MVLowlmt:=0.0, MVUpLmt:=100.0, ManResetVal:=0.0, MVTrackSw:=FALSE, MVTrackVal:=0.0, StopMV:=0.0, ErrorMV:=0.0, Alpha:=0.65, ATCalcGain:=1.0, ATHystrs:=0.2)	Operation setting parameters
	InitSetParams	_sINIT_SET_PARAMS	(SampTime:=T#250ms, RngLowLmt:=-200.0, RngUpLmt:=1300.0, DirOpr:=FALSE)	Initial setting parameters
	ManMV	REAL	0.0	Manual manipulated variable
	ATBusy	BOOL	FALSE	Autotuning busy
	PID_ErrorID	WORD	WORD#16#0	PIDAT error code
	PID_Error	BOOL	FALSE	PIDAT error
	MV	REAL	0.0	Manipulated variable
	ATDone	BOOL	FALSE	Autotuning normal completion
	TPO_Error	BOOL	FALSE	TimeProportionalOut error
	PIDbank	ARRAY[0..7] OF sPID_BANK	[8((PB:=10, Tl:=T#233s, TD:=T#60s))]	Storage array for optimum PID parameters
	ACSP	AC_StepProgram		
	PID	PIDAT		
	TPO	TimeProportionalOut		

External Variables	Variable	Data type	Constant	Comment
	N1_Ch1_Measured_Value_REAL	REAL	---	Channel measured value (REAL)
	N2_Output_Bit_00	BOOL	---	Output bit

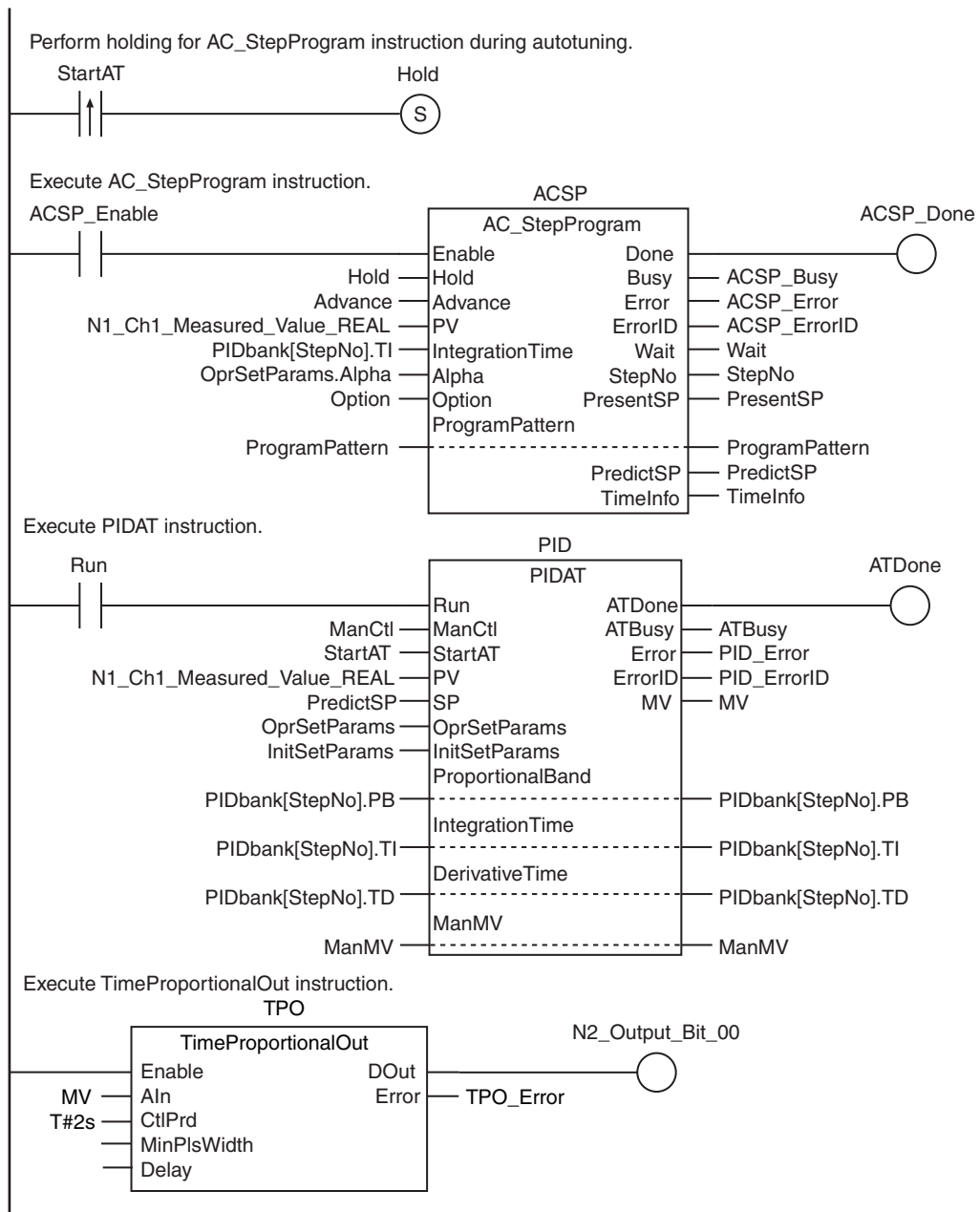

ST

Internal Variables	Variable	Data type	Initial value	Comment
	ACSP_Enable	BOOL	FALSE	Enable for AC_StepProgram
	Hold	BOOL	FALSE	Hold
	Advance	BOOL	FALSE	Advance
	Option	_sAC_STEP_OPTION	(StartAtPV:=FALSE, StartStepNo:=0, EndStepNo:=7, Reserved:=[32(16#0)])	Option
	ProgramPattern	ARRAY[0..7] OF _sAC_STEP_DATA	[(ReachSP:=30.0, TimeWidth:=T#0s, WaitWidth:=3.0, WaitTimeLimit:=T#1m), (ReachSP:=100.0, TimeWidth:=T#10m, WaitWidth:=3.0, WaitTimeLimit:=T#1m), (ReachSP:=120.0, TimeWidth:=T#15m, WaitWidth:=3.0, WaitTimeLimit:=T#1m), (ReachSP:=150.0, TimeWidth:=T#0s, WaitWidth:=3.0, WaitTimeLimit:=T#1m), (ReachSP:=150.0, TimeWidth:=T#15m, WaitWidth:=3.0, WaitTimeLimit:=T#1m), (ReachSP:=80.0, TimeWidth:=T#4m, WaitWidth:=3.0, WaitTimeLimit:=T#1m), (ReachSP:=80.0, TimeWidth:=T#5m, WaitWidth:=3.0, WaitTimeLimit:=T#1m), (ReachSP:=10.0, TimeWidth:=T#0s, WaitWidth:=3.0, WaitTimeLimit:=T#1m)]	Program pattern
	ACSP_Busy	BOOL	FALSE	Execution of AC_StepProgram in progress
	ACSP_Error	BOOL	FALSE	AC_StepProgram error
	ACSP_ErrorID	WORD	WORD#16#0	AC_StepProgram error code
	Wait	BOOL	FALSE	Waiting
	StepNo	USINT	0	Present step number
	PresentSP	REAL	0.0	Present set point
	PredictSP	REAL	0.0	Predicted set point

Internal Variables	Variable	Data type	Initial value	Comment
	TimeInfo	_sAC_STEP_TIME	(ProgramTime:=T#0s, ElapseTime:=T#0s, ProgressTime:=T#0s, LeftTime:=T#0s, StepProgressTime:=T#0s, StepLeftTime:=T#0s)	Clock information
	ACSP_Done	BOOL	FALSE	AC_StepProgram completion
	Run	BOOL	FALSE	PIDAT instruction execution condition
	ManCtl	BOOL	FALSE	Manual/auto control
	StartAT	BOOL	FALSE	Autotuning execution condition
	PreStartAT	BOOL	TRUE	Autotuning execution condition for previous task period
	OprSetParams	_sOPR_SET_PARAMS	(MVLowLmt:=0.0, MVUpLmt:=100.0, ManResetVal:=0.0, MVTrackSw:=FALSE, MVTrackVal:=0.0, StopMV:=0.0, ErrorMV:=0.0, Alpha:=0.65, ATCalcGain:=1.0, ATHystrs:=0.2)	Operation setting parameters
	InitSetParams	_sINIT_SET_PARAMS	(SampTime:=T#250ms, RngLowLmt:=-200.0, RngUpLmt:=1300.0, DirOpr:=FALSE)	Initial setting parameters
	ManMV	REAL	0.0	Manual manipulated variable
	ATBusy	BOOL	FALSE	Autotuning busy
	PID_ErrorID	WORD	WORD#16#0	PIDAT error code
	PID_Error	BOOL	FALSE	PIDAT error
	MV	REAL	0.0	Manipulated variable
	ATDone	BOOL	FALSE	Autotuning normal completion
	TPO_Error	BOOL	FALSE	TimeProportionalOut error
	PIDbank	ARRAY[0..7] OF sPID_BANK	[8((PB:=10, TI:=T#233s, TD:=T#60s))]	Storage array for optimum PID parameters
	TPO_Enable	BOOL	FALSE	Enable for TimeProportionalOut
	MinPisWidth	REAL	0.0	Minimum pulse width
	Delay	REAL	0.0	Delay
	ACSP	AC_StepProgram		
	PID	PIDAT		
	TPO	TimeProportionalOut		

External Variables	Variable	Data type	Constant	Comment
	N1_Ch1_Measured_Value_REAL	REAL	---	Channel measured value (REAL)
	N2_Output_Bit_00	BOOL	---	Output bit

```

TPO_Enable := TRUE;

// Perform holding for AC_StepProgram instruction during autotuning.
IF StartAT AND PreStartAT=FALSE THEN
  Hold := TRUE;
END_IF;
PreStartAT := StartAT;

// Execute AC_StepProgram instruction.
IF ACSP_Enable THEN
  ACSP(Enable      :=ACSP_Enable,
       Hold        :=Hold,
       Advance     :=Advance,
       PV          :=N1_Ch1_Measured_Value_REAL,
       IntegrationTime:=PIDbank[StepNo].TI,
       Alpha       :=OprSetParams.Alpha,
       Option      :=Option,
       ProgramPattern :=ProgramPattern,
       Done        =>ACSP_Done,
       Busy        =>ACSP_Busy,
       Error       =>ACSP_Error,
       ErrorID     =>ACSP_ErrorID,
       Wait        =>Wait,
       StepNo      =>StepNo,
       PresentSP   =>PresentSP,
       PredictSP   =>PredictSP,
       TimeInfo    =>TimeInfo);
END_IF;

// Execute PIDAT instruction.
IF Run THEN
  PID(Run          :=Run,
      ManCtl       :=ManCtl,
      StartAT      :=StartAT,
      PV           :=N1_Ch1_Measured_Value_REAL,
      SP           :=PredictSP,
      OprSetParams :=OprSetParams,
      InitSetParams :=InitSetParams,
      ProportionalBand:=PIDbank[StepNo].PB,
      IntegrationTime :=PIDbank[StepNo].TI,
      DerivativeTime :=PIDbank[StepNo].TD,
      ManMV        :=ManMV,
      ATDone       =>ATDone,
      ATBusy       =>ATBusy,
      Error        =>PID_Error,
      ErrorID      =>PID_ErrorID,
      MV=>MV);
END_IF;

// Execute TimeProportionalOut instruction.
TPO(Enable      :=TPO_Enable,
    AIn         :=MV,
    CtlPrd      :=T#2s,
    MinPlsWidth:=MinPlsWidth,
    Delay       :=Delay,
    DOut        =>N2_Output_Bit_00,
    Error       =>TPO_Error);

```

System Control Instructions

Instruction	Name	Page
TraceSamp	Data Trace Sampling	2-798
TraceTrig	Data Trace Trigger	2-801
GetTraceStatus	Read Data Trace Status	2-804
SetAlarm	Create User-defined Error	2-808
ResetAlarm	Reset User-defined Error	2-813
GetAlarm	Get User-defined Error Status	2-815
ResetPLCError	Reset PLC Controller Error	2-817
GetPLCError	Get PLC Controller Error Status	2-820
ResetCJBError	Reset CJ Bus Controller Error	2-822
GetCJBError	Get I/O Bus Error Status	2-824
GetEIPError	Get EtherNet/IP Error Status	2-826
ResetMCErr	Reset Motion Control Error	2-828
GetMCErr	Get Motion Control Error Status	2-833
ResetECErr	Reset EtherCAT Error	2-835
GetECErr	Get EtherCAT Error Status	2-837
ResetNXBError	Reset NX Bus Error	2-840
GetNXBError	Get NX Bus Error Status	2-842
GetNXUnitError	Get NX Unit Error Status	2-844
SetInfo	Create User-defined Information	2-852
ResetUnit	Restart Unit	2-854
GetNTPStatus	Read NTP Status	2-858
RestartNXUnit	Restart NX Unit	2-860
NX_ChangeWriteMode	Change to NX Unit Write Mode	2-866
NX_SaveParam	Save NX Unit Parameters	2-871
NX_ReadTotalPowerOnTime	Read NX Unit Total Power ON Time	2-877
PLC_ReadTotalPowerOnTime	Read PLC Total Power ON Time	2-885

TraceSamp

The TraceSamp instruction performs sampling for a data trace.

Instruction	Name	FB/FUN	Graphic expression	ST expression
TraceSamp	Data Trace Sampling	FUN	<pre> graph LR subgraph TraceSamp EN[EN] TraceNo[TraceNo] Point[Point] ENO[ENO] end ENO --- Out[Out] </pre>	TraceSamp(TraceNo, Point);

Variables

Name	Meaning	I/O	Description	Valid range	Unit	Default
TraceNo	Trace number	Input	Trace number	*1	---	0
Point	Sampling point number		Sampling point number	Depends on data type.		
Out	Return value	Output	Always TRUE	TRUE only	---	---

*1 The range is 0 to 3 for an NX701 or NJ501 CPU Unit, and for an NY-series Controller.
The range is 0 to 1 for an NX1P2, NJ301 or NJ101 CPU Unit.

	Boolean	Bit strings				Integers								Real numbers		Times, durations, dates, and text strings				
	BOOL	BYTE	WORD	DWORD	LWORD	USINT	UINT	UDINT	ULINT	SINT	INT	DINT	LINT	REAL	LREAL	TIME	DATE	TOD	DT	STRING
TraceNo						OK														
Point						OK														
Out	OK																			

Function

The TraceSamp instruction performs sampling for a data trace. The sampling settings are specified from the Sysmac Studio. The present values for all variables that are set to be sampled are read and stored with trace number *TraceNo* and sampling point number *Point* in trace memory. This instruction is executed only during execution of data tracing and only when the sampling timing is set to sampling instructions from the Sysmac Studio.

The following figure shows a programming example. Trace number 1 and sampling point number 2 are attached, and the present values of all variables to be sampled are stored in trace memory.

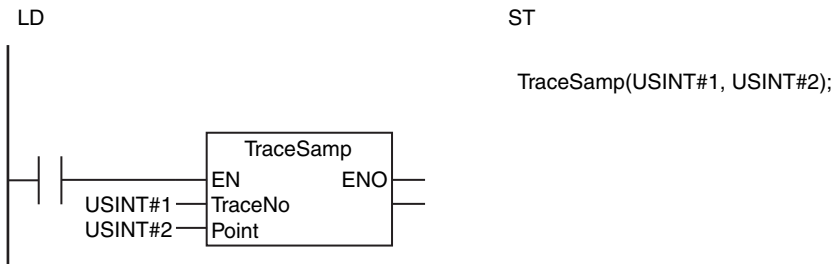

The present values for all variables that are set to be sampled are read and stored with trace number *TraceNo* and sampling point number *Point* in trace memory.

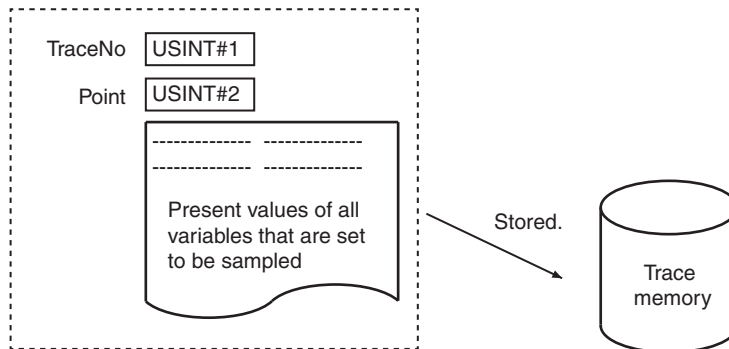

Related System-defined Variables

Name	Meaning	Data type	Description
*1	Trace Information	*2	Trace information*3

*1 NX701 or NJ501 CPU Unit, and NY-series Controller: The variable name is `_PLC_TraceSta[0..3]`.
 NX1P2, NJ301 or NJ101 CPU Unit: The variable name is `_PLC_TraceSta[0..1]`.

*2 `_sTRACE_STA[]`

*3 Refer to the *NJ/NX-series CPU Unit Software User's Manual* (Cat. No. W501) or *NY-series Industrial Panel PC / Industrial Box PC Software User's Manual* (Cat. No. W558) for details.

Additional Information

- Refer to the *NJ/NX-series CPU Unit Software User's Manual* (Cat. No. W501) or *NY-series Industrial Panel PC / Industrial Box PC Software User's Manual* (Cat. No. W558) for details on data tracing.
- Tracing is used to sample the values of specified variables under specified conditions. The conditions are specified from the Sysmac Studio.
- This instruction can be located in more than one place in the user program. Programming can be written to sample according to specific conditions.
- Point* can be suitably set so that you can see which sampled values on the Data Trace Window in the Sysmac Studio were returned by which TraceSamp instruction. *Point* will default to 0 if it is omitted.

Precautions for Correct Use

- Return value *Out* is not used when the instruction is used in ST.
- In the following cases, nothing is done and the instruction ends normally.
 - Data tracing is stopped.
 - The sampling timing is not set to sampling instructions in the trace settings.
 - The value of *TraceNo* is not the trace number set from the Sysmac Studio.
- An error occurs in the following case. *ENO* will be FALSE.
 - The value of *TraceNo* is outside of the valid range.

Sample Programming

Here, sampling is performed at the end of each process A to D. The values of the variables are stored at each point.

LD

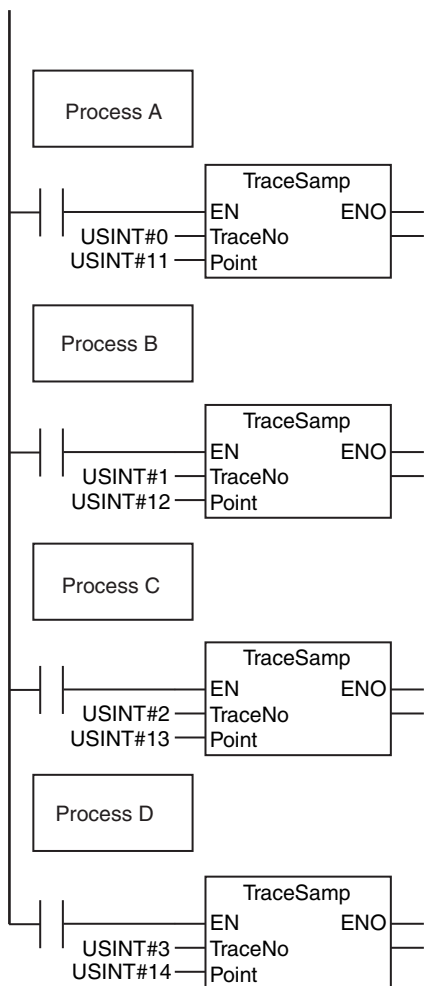

ST

```

Process A
TraceSamp(USINT#0, USINT#11);
Process B
TraceSamp(USINT#1, USINT#12);
Process C
TraceSamp(USINT#2, USINT#13);
Process D
TraceSamp(USINT#3, USINT#14);
    
```

TraceTrig

The TraceTrig instruction generates a trigger for data tracing.

Instruction	Name	FB/FUN	Graphic expression	ST expression
TraceTrig	Data Trace Trigger	FUN		TraceTrig(TraceNo);

Variables

Name	Meaning	I/O	Description	Valid range	Unit	Default
TraceNo	Trace number	Input	Trace number	*1	---	0
Out	Return value	Output	Always TRUE	TRUE only	---	---

*1 The range is 0 to 3 for an NX701 or NJ501 CPU Unit, and for an NY-series Controller.
The range is 0 to 1 for an NX1P2, NJ301 or NJ101 CPU Unit.

	Boolean	Bit strings				Integers							Real numbers		Times, durations, dates, and text strings					
	BOOL	BYTE	WORD	DWORD	LWORD	USINT	UINT	UDINT	ULINT	SINT	INT	DINT	LINT	REAL	LREAL	TIME	DATE	TOD	DT	STRING
TraceNo						OK														
Out	OK																			

Function

The TraceTrig instruction generates a trigger for data tracing. It does not matter whether the trigger conditions that were set from the Sysmac Studio have been met. Sampling starts if data tracing is in progress for trace number *TraceNo* when the instruction is executed.

The following figure shows a programming example. Here, a data trace trigger is generated for trace number 1.

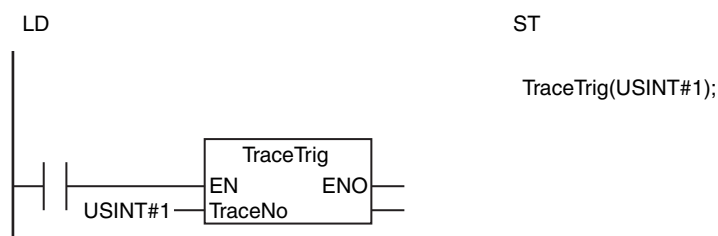

Here, a data trace trigger is generated for trace number *TraceNo*.

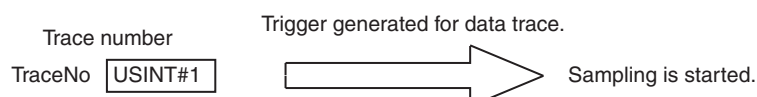

Related System-defined Variables

Name	Meaning	Data type	Description
*1	Trace Information	*2	Trace information*3

*1 NX701 or NJ501 CPU Unit, and NY-series Controller: The variable name is `_PLC_TraceSta[0..3]`.
 NX1P2, NJ301 or NJ101 CPU Unit: The variable name is `_PLC_TraceSta[0..1]`.

*2 `_sTRACE_STA[]`

*3 Refer to the *NJ/NX-series CPU Unit Software User's Manual* (Cat. No. W501) or *NY-series Industrial Panel PC / Industrial Box PC Software User's Manual* (Cat. No. W558) for details.

Additional Information

- Refer to the *NJ/NX-series CPU Unit Software User's Manual* (Cat. No. W501) or *NY-series Industrial Panel PC / Industrial Box PC Software User's Manual* (Cat. No. W558) for details on data tracing.
- This instruction can be located in more than one place in the user program. Programming can be written to generate a trigger according to specific conditions.
- Programming can be written to generate triggers in ways that are not possible for normal trigger conditions settings, such as programming to generate a trigger based on a comparison of two variables.

Precautions for Correct Use

- Return value *Out* is not used when the instruction is used in ST.
- In the following cases, nothing is done and the instruction ends normally.
 - Data tracing is stopped.
 - The trigger condition has already been met.
 - The value of *TraceNo* is not the trace number set from the Sysmac Studio.
 - A continuous trace is specified as the trace type for the trace number that is specified with *TraceNo*.
- An error occurs in the following case. *ENO* will be FALSE.
 - The value of *TraceNo* is outside of the valid range.

Sample Programming

Here, a data trace trigger is generated to store the values of variables when the current speed exceeds the maximum speed. The TraceTrig instruction is executed when the value of *Current_speed* exceeds the value of *Max_speed*.

LD

Variable	Data type	Initial value	Comment
Current_speed	INT	0	Current speed
Max_speed	INT	20	Maximum speed

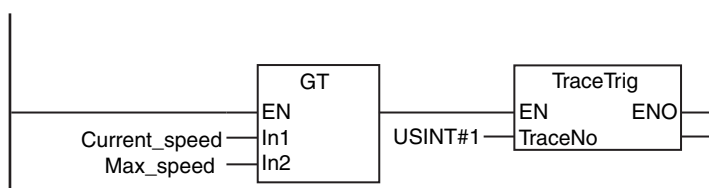

ST

Variable	Data type	Initial value	Comment
Current_speed	INT	0	Current speed
Max_speed	INT	20	Maximum speed

```
IF (Current_speed > Max_speed) THEN  
    TraceTrig(USINT#1);  
END_IF;
```

GetTraceStatus

The GetTraceStatus instruction reads the execution status of a data trace.

Instruction	Name	FB/FUN	Graphic expression	ST expression
GetTraceStatus	Read Data Trace Status	FUN		GetTraceStatus(TraceNo, IsStart, IsComplete, ParamErr, IsTrigger);

Variables

Name	Meaning	I/O	Description	Valid range	Unit	Default
TraceNo	Trace number	Input	Trace number	*1	---	0
Out	Return value	Output	Always TRUE	TRUE only	---	---
IsStart	Executing flag		TRUE: Data trace in progress. FALSE: Data trace not in progress.	Depends on data type.		
IsComplete	Completed flag		TRUE: Data trace was completed. FALSE: Data trace in progress or not executed.			
ParamErr	Parameter error flag		TRUE: Data trace setting error. FALSE: No data trace setting error.			
IsTrigger	Trigger flag		TRUE: Data trace trigger condition met. FALSE: Data trace trigger condition not met.			

*1 The range is 0 to 3 for an NX701 or NJ501 CPU Unit, and for an NY-series Controller.
The range is 0 to 1 for an NX1P2, NJ301 or NJ101 CPU Unit.

	Boolean	Bit strings					Integers							Real numbers		Times, durations, dates, and text strings				
	BOOL	BYTE	WORD	DWORD	LWORD	USINT	UINT	UDINT	ULINT	SINT	INT	DINT	LINT	REAL	LREAL	TIME	DATE	TOD	DT	STRING
TraceNo						OK														
Out	OK																			
IsStart	OK																			

	Boolean	Bit strings				Integers							Real numbers		Times, durations, dates, and text strings					
	BOOL	BYTE	WORD	DWORD	LWORD	USINT	UINT	UDINT	ULINT	SINT	INT	DINT	LINT	REAL	LREAL	TIME	DATE	TOD	DT	STRING
IsComplete	OK																			
ParamErr	OK																			
IsTrigger	OK																			

Function

The GetTraceStatus instruction reads the execution status of the data trace that is specified with trace number *TraceNo*. The status that is read is output to execution flag *IsStart*, completed flag *IsComplete*, parameter error flag *ParamErr*, and trigger flag *IsTrigger*.

The value of *ParamErr* changes to TRUE when one of the following errors is found in the trace settings.

- A variable that is specified in the trigger or sampling settings does not exist.
- Sampling is set to be performed on a specified task period, but the specified task does not exist.

The following figure shows a programming example. The GetTraceStatus instruction reads the execution status of the data trace with trace number 1.

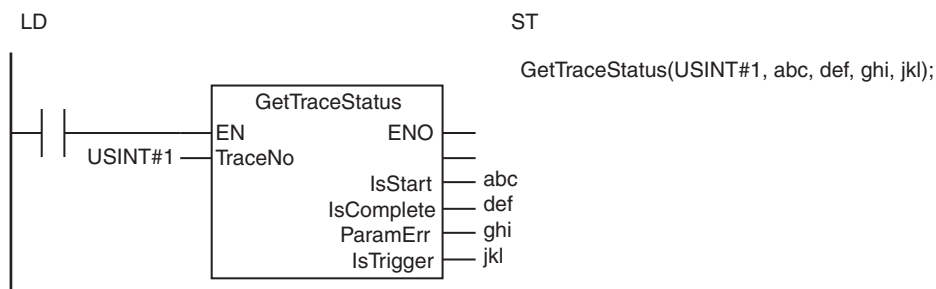

The GetTraceStatus instruction reads the execution status of the data trace that is specified with trace number *TraceNo*.

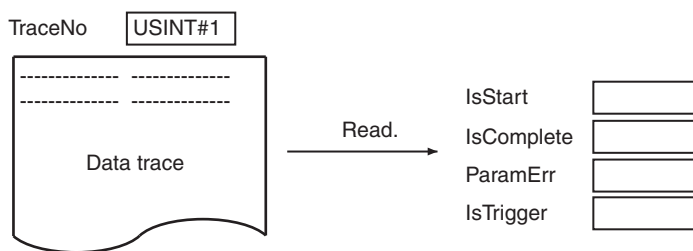

Related System-defined Variables

Name	Meaning	Data type	Description
*1	Trace Information	*2	Trace information*3

*1 NX701 or NJ501 CPU Unit, and NY-series Controller: The variable name is `_PLC_TraceSta[0..3]`.
 NX1P2, NJ301 or NJ101 CPU Unit: The variable name is `_PLC_TraceSta[0..1]`.

*2 `_sTRACE_STA[]`

*3 Refer to the *NJ/NX-series CPU Unit Software User's Manual* (Cat. No. W501) or *NY-series Industrial Panel PC / Industrial Box PC Software User's Manual* (Cat. No. W558) for details.

Additional Information

Refer to the *NJ/NX-series CPU Unit Software User's Manual* (Cat. No. W501) or *NY-series Industrial Panel PC / Industrial Box PC Software User's Manual* (Cat. No. W558) for details on data tracing.

Precautions for Correct Use

- Return value *Out* is not used when the instruction is used in ST.
- This instruction reads the contents of the `_PLC_TraceSta[]` system-defined variable. You cannot access this variable directly. Always use this instruction to read the contents of the variable.
- An error occurs in the following case. *ENO* will be FALSE.
 - The value of *TraceNo* is outside of the valid range.

Sample Programming

In this sample, the GetTraceStatus instruction reads the execution status of the data trace with trace number 3. If the data trace is in progress, the TraceTrig instruction is executed to trigger data tracing.

LD

Variable	Data type	Initial value	Comment
StaFlag	BOOL	FALSE	Trace execution status
A	BOOL	FALSE	
B	BOOL	FALSE	

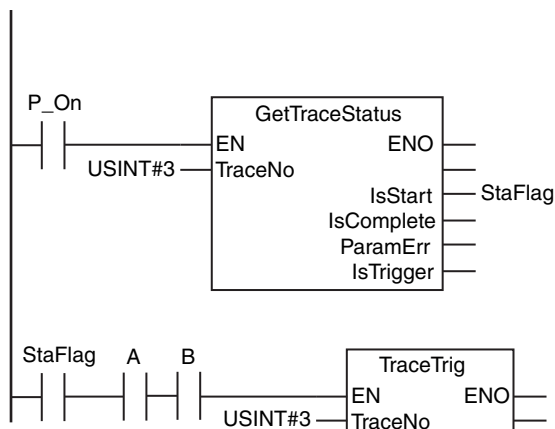

ST

Variable	Data type	Initial value	Comment
StaFlag	BOOL	FALSE	Trace execution status
A	BOOL	FALSE	
B	BOOL	FALSE	

```
GetTraceStatus (TraceNo:=USINT#3, IsStart=>StaFlag);
```

```
IF ( (StaFlag=TRUE) AND (A=TRUE) AND (B=TRUE) ) THEN
  TraceTrig(TraceNo:=USINT#3);
END_IF;
```

SetAlarm

The SetAlarm instruction creates a user-defined error.

Instruction	Name	FB/FUN	Graphic expression	ST expression
SetAlarm	Create User-defined Error	FUN		SetAlarm(Code, Info1, Info2);

Variables

Name	Meaning	I/O	Description	Valid range	Unit	Default
Code	Event code	Input	Event code of user-defined error to generate	1 to 40000	---	1
Info1	Attached information 1		Values recorded in event log when the user-defined error is generated	Depends on data type.		*
Info2	Attached information 2					
Out	Return value	Output	Always TRUE	TRUE only	---	---

* If you omit the input parameter, the default value is not applied. A building error will occur.

	Boolean	Bit strings					Integers							Real numbers	Times, durations, dates, and text strings					
	BOOL	BYTE	WORD	DWORD	LWORD	USINT	UINT	UDINT	ULINT	SINT	INT	DINT	LINT	REAL	LREAL	TIME	DATE	TOD	DT	STRING
Code						OK														
Info1	OK	OK	OK	OK	OK	OK	OK	OK	OK	OK	OK	OK	OK	OK	OK	OK	OK	OK	OK	
Info2	OK	OK	OK	OK	OK	OK	OK	OK	OK	OK	OK	OK	OK	OK	OK	OK	OK	OK	OK	
Out	OK																			

Function

The SetAlarm instruction generates the user-defined error that corresponds to event code *Code*. Event codes are defined in the event setting table on the Sysmac Studio. The time of occurrence, event name, event group, event code *Code*, event level, additional information *Info1*, additional information *Info2*, and detailed information are stored in the user event log area that corresponds to the level of the event code. The value for the time of occurrence is automatically obtained. The event name, event group, and detailed information that are set from the Sysmac Studio are recorded. The event level that corresponds to the event code is recorded. The event levels are given below. The smaller the event code is, the higher the event level is.

Event code	Classification: User fault level
1 to 5000	1
5001 to 10000	2
10001 to 15000	3
15001 to 20000	4
20001 to 25000	5
25001 to 30000	6
30001 to 35000	7
35001 to 40000	8

The following figure shows a programming example. A user-defined error with event code 101 is generated. The values of variables *abc* and *def* are stored as attached information.

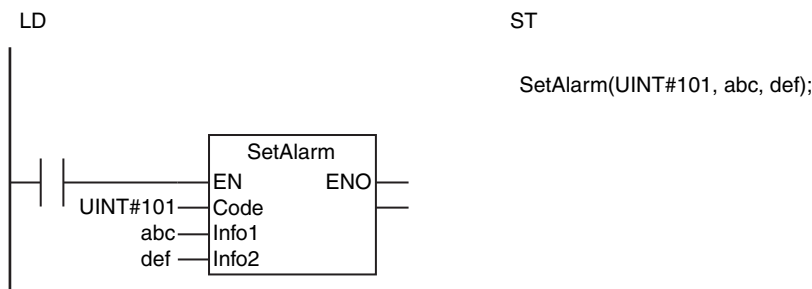

A user-defined error with event code *Code* is generated. Also, the time of occurrence, event name, event group, event code *Code*, event level, additional information *Info1*, additional information *Info2*, and detailed information are stored in the user event log area.

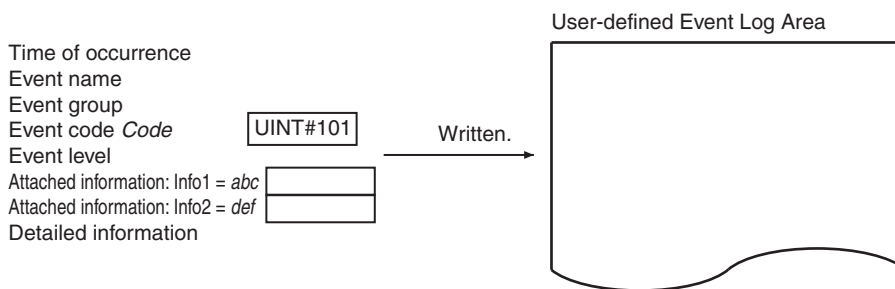
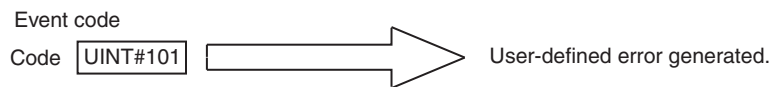

Related System-defined Variables

Name	Meaning	Data type	Description
<u>_</u> AlarmFlag	Error Status of User-defined Errors	WORD	These flags indicate when user-defined errors are detected. Bit 0 to bit 7 indicate the status of user-defined error levels 1 to 8.*1

*1 Refer to the *NJ/NX-series CPU Unit Software User's Manual* (Cat. No. W501) or *NY-series Industrial Panel PC / Industrial Box PC Software User's Manual* (Cat. No. W558) for details.

Additional Information

You can specify either global variables or local variables for *Info1* and *Info2*.

Precautions for Correct Use

- Up to 32 user-defined errors can be generated in each of the eight event levels (for up to 256 user-defined errors total).
- If a user-defined error for the same event code already exists, the new error is not recorded in the event log.
- Always use variables for the input parameters that pass *Info1* and *Info2*. If you use a constant, a building error will occur.
- An error does not occur even if the value of *Code* is not set as a event code on the Sysmac Studio. If the event code is not registered, the event group and detailed information are not recorded in the user-defined event log. The value of *Code* is recorded for the event name.
- Return value *Out* is not used when the instruction is used in ST.
- An error occurs in the following cases. *ENO* will be FALSE.
 - The value of *Code* is outside of the valid range.
 - An attempt was made to generate more than the maximum number of user-defined errors.

Sample Programming

In this sample, the value of variable *A* changes between TRUE and FALSE every five seconds. The value of *A* is monitored. If it does not change for more than five seconds, a user-defined error with event code 102 is generated. UINT#123 and UINT#456 are given as the attached information.

When variable *F* changes to TRUE, the user-defined error is cleared.

LD

Internal Variables	Variable	Data type	Initial value
	A	BOOL	FALSE
	B	BOOL	FALSE
	C	BOOL	FALSE
	F	BOOL	FALSE
	Abc	UINT	123
	Def	UINT	456
	TON_instance0	TON	
	TON_instance1	TON	

External Variables	Variable	Data type	Constant	Comment
	_AlarmFlag	WORD	✓	Error Status of User-defined Errors

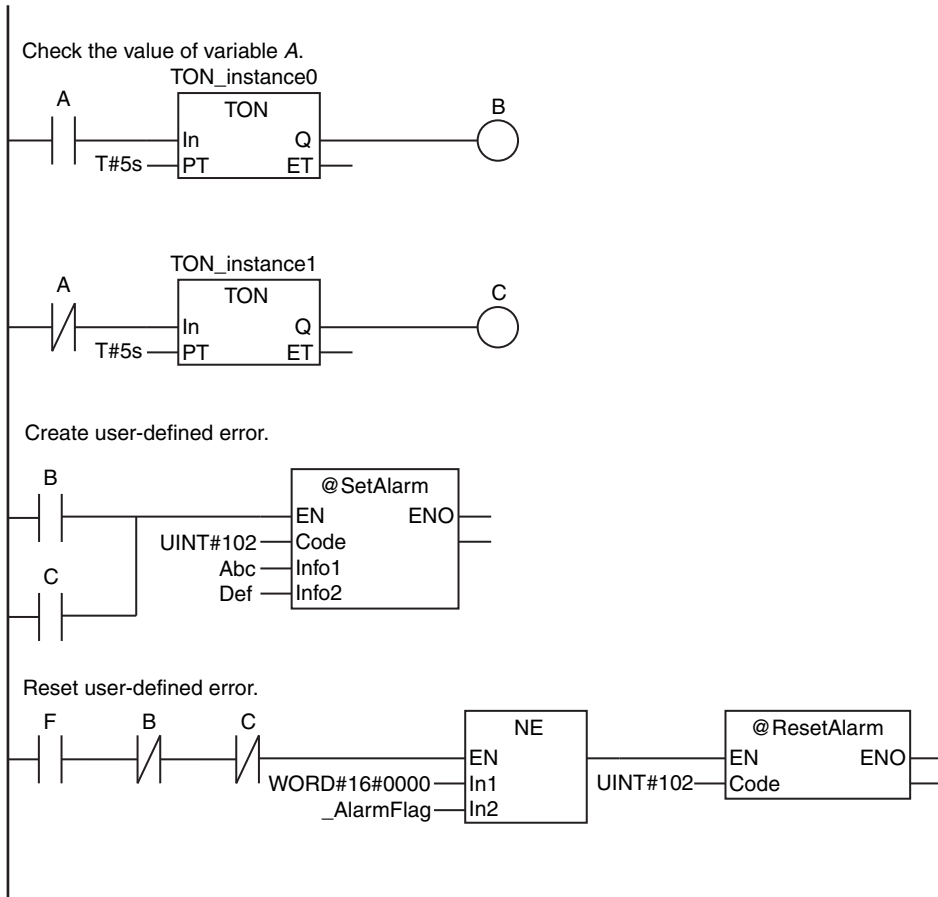

ST

Internal Variables	Variable	Data type	Initial value
	A	BOOL	FALSE
	B	BOOL	FALSE
	C	BOOL	FALSE
	F	BOOL	FALSE
	Abc	UINT	123
	Def	UINT	456
	TON_instance0	TON	
	TON_instance1	TON	

External Variables	Variable	Data type	Constant	Comment
	_AlarmFlag	WORD	✓	Error Status of User-defined Errors

```
// Check the value of variable A.
IF (A=TRUE) THEN
    TON_instance0(In:=TRUE, PT:=T#5s, Q=>B);
ELSE
    TON_instance0(In:=FALSE, Q=>B);
END_IF;

IF (A=FALSE) THEN
    TON_instance1(In:=TRUE, PT:=T#5s, Q=>C);
ELSE
    TON_instance1(In:=FALSE, Q=>C);
END_IF;

// Create user-defined error.
IF (B=TRUE) OR (C=TRUE) THEN
    SetAlarm(
        Code :=UINT#102
        Info1 :=Abc,
        info2 :=Def);
END_IF;

// Reset user-defined error.
IF (F=TRUE) & (B=FALSE) & (C=FALSE) & (_AlarmFlag<>WORD#16#0000) THEN
    ResetAlarm(Code:=UINT#102);
END_IF;
```

ResetAlarm

The ResetAlarm instruction resets a user-defined error.

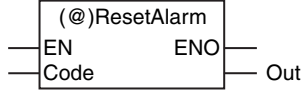
Instruction	Name	FB/FUN	Graphic expression	ST expression
ResetAlarm	Reset User-defined Error	FUN		ResetAlarm(Code);

Variables

Name	Meaning	I/O	Description	Valid range	Unit	Default
Code	Event code	Input	Event code of user-defined error to reset 16#0:Reset all application errors.	Depends on data type.	---	0
Out	Return value	Output	Always TRUE	TRUE only	---	---

	Boolean	Bit strings				Integers								Real numbers	Times, durations, dates, and text strings					
	BOOL	BYTE	WORD	DWORD	LWORD	USINT	UINT	UDINT	ULINT	SINT	INT	DINT	LINT	REAL	LREAL	TIME	DATE	TOD	DT	STRING
Code							OK													
Out	OK																			

Function

The ResetAlarm instruction resets the user-defined error specified by event code *Code*. An event is then recorded in the user-defined event log area to show that a specific user-defined error was reset. The event code for this event is 65533 and the level is user information.

If the value of *Code* is 0, all current user-defined errors are reset. An event is then recorded in the user-defined event log area to show that all user-defined errors were reset. The event code for this event is 65534 and the level is user information.

The following figure shows a programming example. A user-defined error for event code 101 is reset.

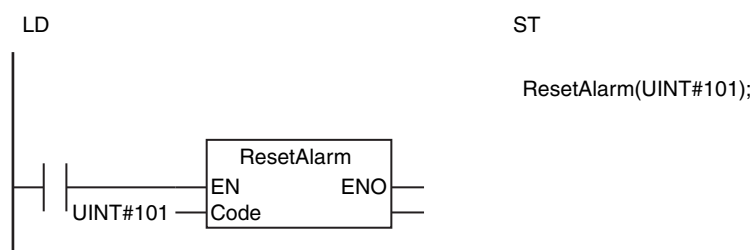

The ResetAlarm instruction resets the user-defined error specified by event code *Code*. Also an event is recorded in the user-defined event log area to show that a specific user-defined error was reset.

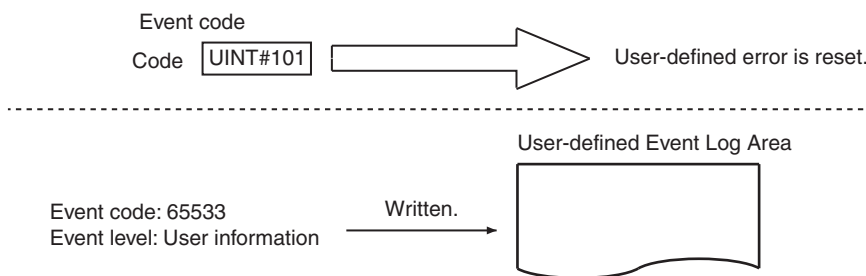

Related System-defined Variables

Name	Meaning	Data type	Description
_AlarmFlag	Error Status of User-defined Errors	WORD	These flags indicate when user-defined errors are detected. Bit 0 to bit 7 indicate the status of user-defined error levels 1 to 8.*1

*1 Refer to the *NJ/NX-series CPU Unit Software User's Manual* (Cat. No. W501) or *NY-series Industrial Panel PC / Industrial Box PC Software User's Manual* (Cat. No. W558) for details.

Precautions for Correct Use

- An error does not occur if the user-defined error specified by *Code* has not occurred.
- Return value *Out* is not used when the instruction is used in ST.
- An error occurs in the following case. *ENO* will be FALSE.
 - The value of *Code* is outside of the valid range.

Sample Programming

Refer to the sample programming that is provided for the SetAlarm instruction (page 2-808).

GetAlarm

The GetAlarm instruction gets the highest event level (of user-defined error levels 1 to 8) and the highest level event code of the current user-defined errors.

Instruction	Name	FB/FUN	Graphic expression	ST expression
GetAlarm	Get User-defined Error Status	FUN		Out:=GetAlarm(Level, Code);

Variables

Name	Meaning	I/O	Description	Valid range	Unit	Default
Out	Error flag	Output	TRUE: User-defined error exists. FALSE: No user-defined error	Depends on data type.	---	---
Level	Highest event level		Highest event level of all current user-defined errors 0: No user-defined error 1 to 8: Event level	0 to 8		
Code	Highest level event code		Highest level event code of all current user-defined errors 0: No user-defined error 1 to 40000: Event level	0 to 40000		

	Boolean	Bit strings				Integers							Real numbers	Times, durations, dates, and text strings						
	BOOL	BYTE	WORD	DWORD	LWORD	USINT	UINT	UDINT	ULINT	SINT	INT	DINT	LINT	REAL	LREAL	TIME	DATE	TOD	DT	STRING
Out	OK																			
Level							OK													
Code							OK													

Function

The GetAlarm instruction gets the highest event level and the highest level event code of the current user-defined errors and outputs them to *Level* and *Code*. If there are currently no user-defined errors, the value of error flag *Out* is FALSE. If there is more than one use-defined error at the highest event level, the value of *Code* is the event code for the user-defined error that occurred first.

The following figure shows a programming example.

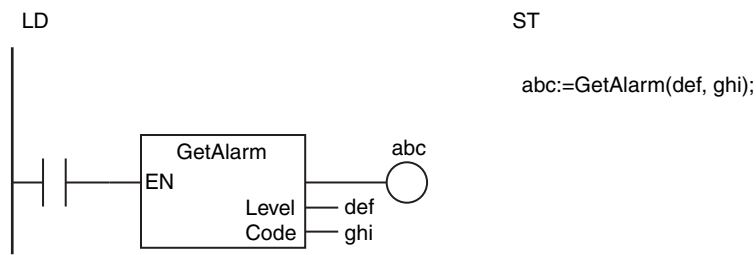

The GetAlarm instruction gets the highest event level and the highest level event code of the current user-defined error and outputs them to *Level* and *Code*.

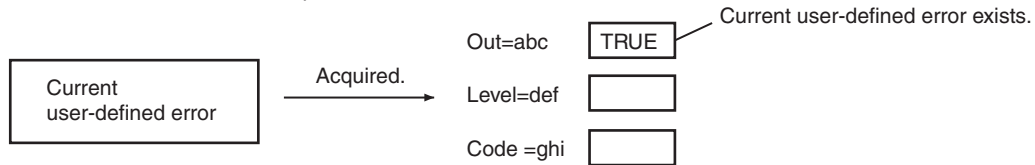

Related System-defined Variables

Name	Meaning	Data type	Description
_AlarmFlag	Error Status of User-defined Errors	WORD	These flags indicate when user-defined errors are detected. Bit 0 to bit 7 indicate the status of user-defined error levels 1 to 8.*1

*1 Refer to the *NJ/NX-series CPU Unit Software User's Manual* (Cat. No. W501) or *NY-series Industrial Panel PC / Industrial Box PC Software User's Manual* (Cat. No. W558) for details.

Precautions for Correct Use

If this instruction is used in a ladder diagram, the value of *Out* changes to FALSE if an error occurs in the previous instruction on the rung.

ResetPLCErr

The ResetPLCErr instruction resets errors in the PLC Function Module.

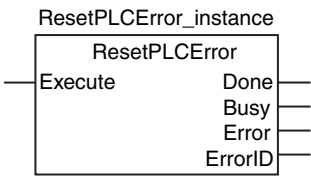
Instruction	Name	FB/FUN	Graphic expression	ST expression
ResetPLCErr	Reset PLC Controller Error	FB		ResetPLCErr(Execute, Done, Busy, Error, ErrorID);

Variables

Only common variables are used.

Function

The ResetPLCErr instruction resets errors in the PLC Function Module.

The following figure shows a programming example.

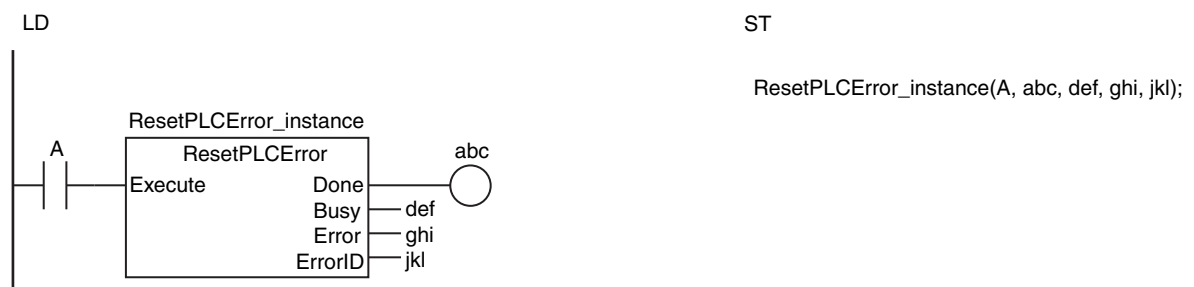

The ResetPLCErr instruction resets errors in the PLC Function Module.

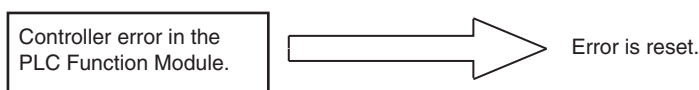

Related System-defined Variables

Name	Meaning	Data type	Description
_PLC_ErrSta	Error Status of PLC Function Module	WORD	Contains the error status of the PLC Function Module.*1

*1 Refer to the *NJ/NX-series CPU Unit Software User's Manual* (Cat. No. W501) or *NY-series Industrial Panel PC / Industrial Box PC Software User's Manual* (Cat. No. W558) for details.

Precautions for Correct Use

The error may not be reset immediately after you execute this instruction. Use the GetPLCErr instruction to confirm that the errors were reset.

Sample Programming

The ResetPLCError instruction is executed when the value of *Trigger* changes to TRUE. Normal end processing is performed if execution of the ResetPLCError instruction ends normally (i.e., if the value of *Done* is TRUE). Error end processing is performed if execution ends in an error (i.e., if the value of *Error* is TRUE).

LD

Variable	Data type	Initial value	Comment
OperatingEnd	BOOL	FALSE	Processing completed
Trigger	BOOL	FALSE	Execution condition
Operating	BOOL	FALSE	Processing
RS_instance	RS		
ResetPLCError_instance	ResetPLCError		

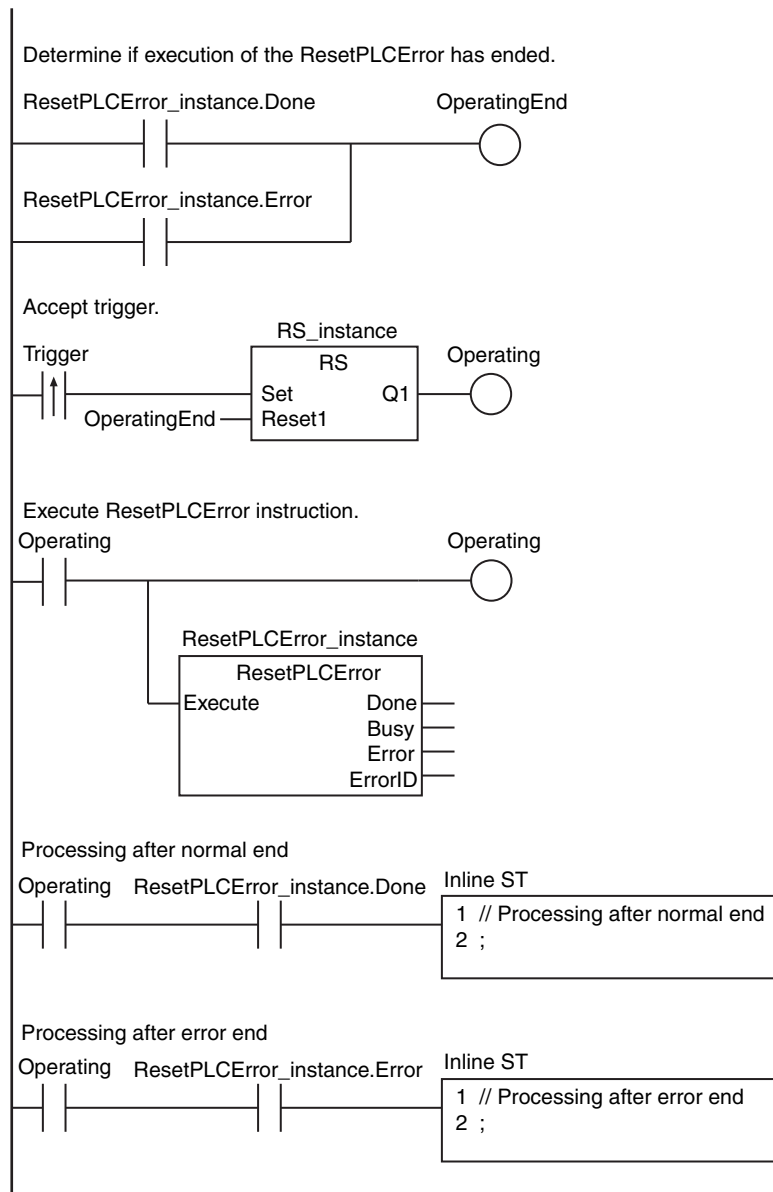

ST

Variable	Data type	Initial value	Comment
Trigger	BOOL	FALSE	Execution condition
LastTrigger	BOOL	FALSE	Value of <i>Trigger</i> from previous task period
OperatingStart	BOOL	FALSE	Processing started
Operating	BOOL	FALSE	Processing
ResetPLCError_instance	ResetPLCError		

```

// Detect when Trigger changes to TRUE.
IF ( (Trigger=TRUE) AND (LastTrigger=FALSE) ) THEN
    OperatingStart:=TRUE;
    Operating      :=TRUE;
END_IF;
LastTrigger:=Trigger;

// Initialize ResetPLCError_instance.
IF (OperatingStart=TRUE) THEN
    ResetPLCError_instance(Execute:=FALSE);
    OperatingStart:=FALSE;
END_IF;

// Execute ResetPLCError instruction.
IF (Operating=TRUE) THEN
    ResetPLCError_instance(Execute:=TRUE);

    IF (ResetPLCError_instance.Done=TRUE) THEN
        // Processing after normal end
        Operating:=FALSE;
    END_IF;

    IF (ResetPLCError_instance.Error=TRUE) THEN
        // Processing after error end
        Operating:=FALSE;
    END_IF;
END_IF;

```

GetPLCError

The GetPLCError instruction gets the highest level status (partial fault or minor fault) and highest level event code of the current Controller errors in the PLC Function Module.

Instruction	Name	FB/FUN	Graphic expression	ST expression
GetPLCError	Get PLC Controller Error Status	FUN		Out:=GetPLCError(Level, Code);

Variables

Name	Meaning	I/O	Description	Valid range	Unit	Default
Out	Error flag	Output	TRUE: Controller error exists. FALSE: No Controller error	Depends on data type.		
Level	Highest level status		Highest level status of all current Controller errors in the PLC Function Module 0: No Controller error 2: Partial fault level 3: Minor fault level	0, 2, or 3		
Code	Highest level event code		Highest level event code of all current Controller errors in the PLC Function Module 16#0000_0000: No Controller error 16#0007_0000 to 16#FFFF_FFFF: Event code	16#00000000 16#00070000 to 16#FFFFFFFF		

	Boolean	Bit strings					Integers							Real numbers		Times, durations, dates, and text strings				
	BOOL	BYTE	WORD	DWORD	LWORD	USINT	UINT	UDINT	ULINT	SINT	INT	DINT	LINT	REAL	LREAL	TIME	DATE	TOD	DT	STRING
Out	OK																			
Level							OK													
Code				OK																

Function

The GetPLCError instruction gets the highest level status and the highest level event code of the current Controller errors in the PLC Function Module and outputs them to *Level* and *Code*.

If there are currently no Controller errors, the value of error flag *Out* is FALSE.

If there is more than one Controller error at the highest event level, the value of *Code* is the event code for the Controller error that occurred first.

The following figure shows a programming example.

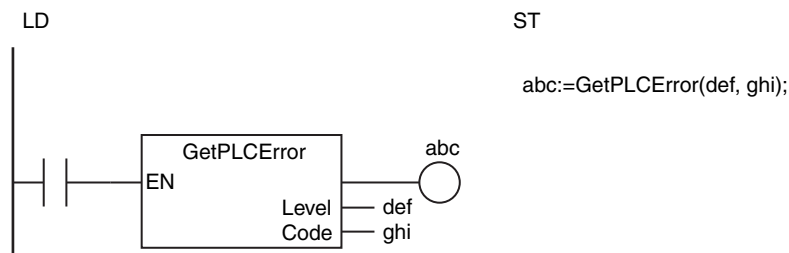

The GetPLCError instruction gets the highest level status and the highest level event code of the current Controller errors in the PLC Function Module and outputs them to *Level* and *Code*.

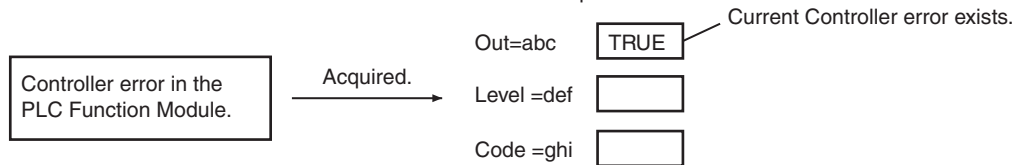

Related System-defined Variables

Name	Meaning	Data type	Description
_PLC_ErrSta	Error Status of PLC Function Module	WORD	Contains the error status of the PLC Function Module.*1

*1 Refer to the *NJ/NX-series CPU Unit Software User's Manual* (Cat. No. W501) or *NY-series Industrial Panel PC / Industrial Box PC Software User's Manual* (Cat. No. W558) for details.

ResetCJBError

The ResetCJBError instruction resets a Controller error in the I/O bus.

Instruction	Name	FB/FUN	Graphic expression	ST expression
ResetCJBError	Reset CJ Bus Controller Error	FB		ResetCJBError_instance(Execute, UnitNo, Done, Busy, Error, ErrorID);



Precautions for Correct Use

You cannot use this instruction in an NX-series CPU Unit.

Variables

Name	Meaning	I/O	Description	Valid range	Unit	Default
UnitNo	Unit number	Input	Unit number for which to reset errors	_CBU_No00 to _CBU_No15, _SIO_No00 to _SIO_No95 _UNIT_ALL	---	_UNIT_ALL

	Boolean	Bit strings					Integers							Real numbers	Times, durations, dates, and text strings					
	BOOL	BYTE	WORD	DWORD	LWORD	USINT	UINT	UDINT	ULINT	SINT	INT	DINT	LINT	REAL	LREAL	TIME	DATE	TOD	DT	STRING
UnitNo																				

UnitNo Refer to *Function* for the enumerators of the enumerated type _eUnitNo.

Function

The ResetCJBError instruction resets a Controller error in the I/O bus. If the Unit specified by unit number *UnitNo* is a CJ-series Special Unit, the Unit is restarted.

The data type of *UnitNo* is enumerated type _eUnitNo. The meanings of the enumerators are as follows:

Enumerators	Meaning
_CBU_No00 to _CBU_No15	Unit number of CPU Bus Unit, 00 to 15
_SIO_No00 to _SIO_No95	Unit number of Special I/O Unit, 00 to 95
_UNIT_ALL	All Units

The following example is for when *UnitNo* is `_CBU_No00`. The Controller error on the I/O bus is reset and the CPU Bus Unit with unit number 0 is restarted.

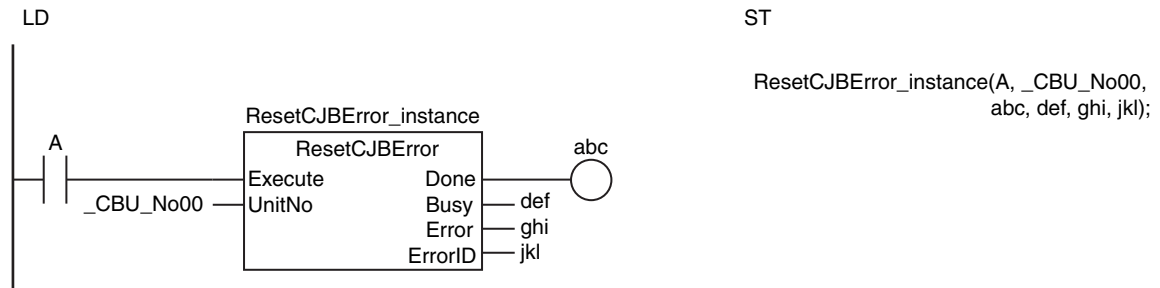

The `ResetCJBError` instruction resets a Controller error in the I/O bus. Also, the CPU Bus Unit with unit number *UnitNo* is restarted.

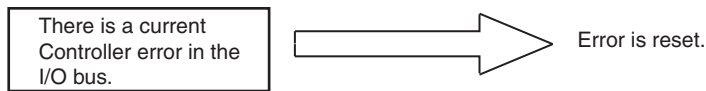

UnitNo = `_CBU_No00`: CPU Bus Unit with unit number 0 is restarted.

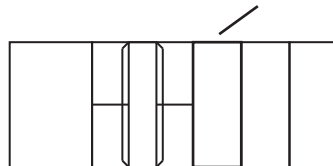

Related System-defined Variables

Name	Meaning	Data type	Description
<code>_CJB_ErrSta</code>	I/O Bus Error Status	WORD	Contains the error status of the I/O bus.*1

*1 Refer to the *NJ/NX-series CPU Unit Software User's Manual* (Cat. No. W501) for details.

Precautions for Correct Use

- The error may not be reset immediately after you execute this instruction. Use the `GetCJBError` instruction to confirm that the errors were reset.
- An error occurs in the following cases. *Error* will be FALSE.
 - The value of *UnitNo* is outside of the valid range.
 - The Unit specified by *UnitNo* does not exist.

GetCJBError

The GetCJBError instruction gets the highest level status and highest level event code of the current Controller errors in the I/O bus of the NJ-series CPU Unit.

Instruction	Name	FB/FUN	Graphic expression	ST expression
GetCJBError	Get I/O Bus Error Status	FUN		Out:=GetCJBError(Level, Code);



Precautions for Correct Use

You cannot use this instruction in an NX-series CPU Unit.

Variables

Name	Meaning	I/O	Description	Valid range	Unit	Default
Out	Error flag	Output	TRUE: Controller error exists. FALSE: No Controller error	Depends on data type.	---	---
Level	Highest level status		Highest level status of all current Controller errors in the I/O bus 0: No Controller error 2: Partial fault level 3: Minor fault level	0, 2, or 3		
Code	Highest level event code		Highest level event code of all current Controller errors in the I/O bus 16#0000_0000: No Controller error 16#0007_0000 to 16#FFFF_FFFF: Event code	16#00000000 16#00070000 to 16#FFFFFFFF		

	Boolean	Bit strings					Integers							Real numbers		Times, durations, dates, and text strings				
	BOOL	BYTE	WORD	DWORD	LWORD	USINT	UINT	UDINT	ULINT	SINT	INT	DINT	LINT	REAL	LREAL	TIME	DATE	TOD	DT	STRING
Out	OK																			
Level							OK													
Code				OK																

Function

The GetCJBError instruction gets the highest level status and the highest level event code of the current Controller errors in the I/O bus and outputs them to *Level* and *Code*. If there are currently no Controller errors, the value of error flag *Out* is FALSE. If there is more than one Controller error at the highest event level, the value of *Code* is the event code for the Controller error that occurred first.

The following figure shows a programming example.

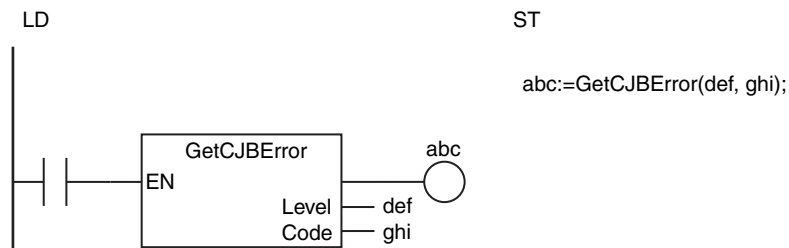

The GetCJBError instruction gets the highest level status and the highest level event code of the current Controller errors in the I/O bus and outputs them to *Level* and *Code*.

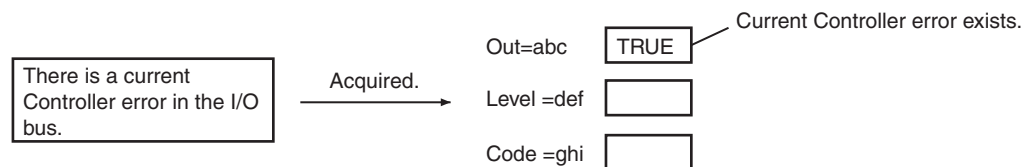

Related System-defined Variables

Name	Meaning	Data type	Description
_CJB_ErrSta	I/O Bus Error Status	WORD	Contains the error status of the I/O bus.*1

*1 Refer to the *NJ/NX-series CPU Unit Software User's Manual* (Cat. No. W501) for details.

GetEIPError

The GetEIPError instruction gets the highest level status (partial fault or minor fault) and highest level event code of the current Controller errors in the EtherNet/IP Function Module.

Instruction	Name	FB/FUN	Graphic expression	ST expression
GetEIPError	Get EtherNet/IP Error Status	FUN		Out:=GetEIPError(Level, Code);

Variables

Name	Meaning	I/O	Description	Valid range	Unit	Default
Out	Error flag	Output	TRUE: Controller error exists. FALSE: No Controller error	Depends on data type.	---	---
Level	Highest event level		Highest level status of all current Controller errors in the EtherNet/IP Function Module 0: No Controller error 2: Partial fault level 3: Minor fault level	0, 2, or 3		
Code	Highest level event code		Highest level event code of all current Controller errors in the EtherNet/IP Function Module 16#0000_0000: No Controller error 16#0007_0000 to 16#FFFF_FFFF: Event code	16#00000000 16#00070000 to 16#FFFFFFFF		

	Boolean	Bit strings					Integers							Real numbers		Times, durations, dates, and text strings				
	BOOL	BYTE	WORD	DWORD	LWORD	USINT	UINT	UDINT	ULINT	SINT	INT	DINT	LINT	REAL	LREAL	TIME	DATE	TOD	DT	STRING
Out	OK																			
Level							OK													
Code				OK																

Function

The GetEIPError instruction gets the highest level status and the highest level event code of the current Controller errors in the EtherNet/IP Function Module and outputs them to *Level* and *Code*. If there are currently no Controller errors, the value of error flag *Out* is FALSE. If there is more than one Controller error at the highest event level, the value of *Code* is the event code for the Controller error that occurred first.

The following figure shows a programming example.

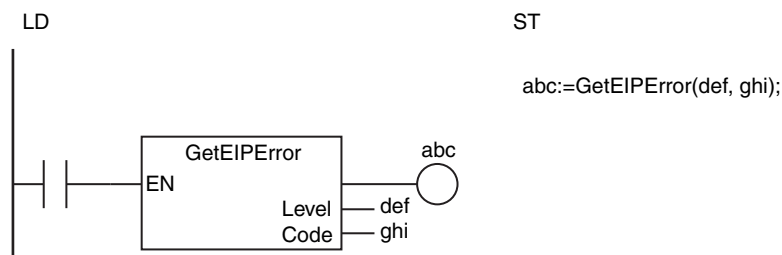

The GetEIPError instruction gets the highest level status and the highest level event code of the current Controller errors in the EtherNet/IP Function Module and outputs them to *Level* and *Code*.

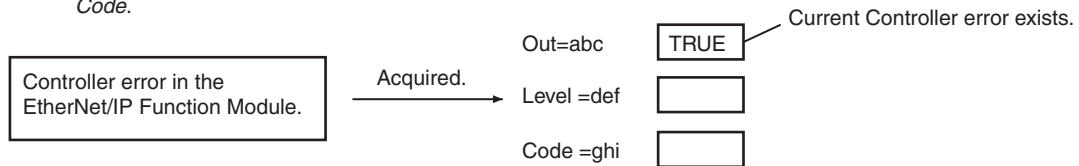

Related System-defined Variables

Name	Meaning	Data type	Description
_EIP_ErrSta	Error Status of EtherNet/IP Function Module	WORD	Contains the error status of the EtherNet/IP Function Module.*1

*1 Refer to the *NJ/NX-series CPU Unit Software User's Manual* (Cat. No. W501) or *NY-series Industrial Panel PC / Industrial Box PC Software User's Manual* (Cat. No. W558) for details.

ResetMCErr

The ResetMCErr instruction resets Controller errors in the Motion Control Function Module.

Instruction	Name	FB/FUN	Graphic expression	ST expression
ResetMCErr	Reset Motion Control Error	FB		ResetMCErr_instance(Execute, Done, Busy, Failure Error, ErrorID);

Variables

Name	Meaning	I/O	Description	Valid range	Unit	Default
Failure	Failure end	Output	TRUE: The errors were not reset. FALSE: The errors were reset normally.	Depends on data type.	---	---

	Boolean	Bit strings					Integers							Real numbers		Times, durations, dates, and text strings				
	BOOL	BYTE	WORD	DWORD	LWORD	USINT	UINT	UDINT	ULINT	SINT	INT	DINT	LINT	REAL	LREAL	TIME	DATE	TOD	DT	STRING
Failure	OK																			

Function

The ResetMCErr instruction resets a Controller error in the Motion Control Function Module. If the errors are not reset, the value of *Failure* changes to TRUE.

No matter what task the program that executes the ResetMCErr is placed in, this instruction resets errors for all axes and all axes groups.

The following figure shows a programming example.

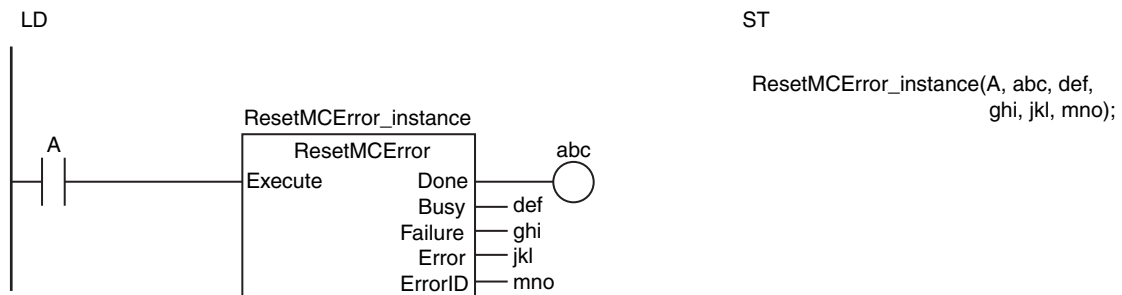

The ResetMCErr instruction resets Controller errors in the Motion Control Function Module. If the errors are not reset, the value of *Failure* changes to TRUE.

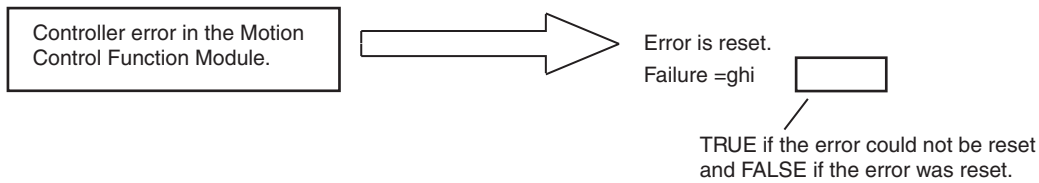

Related System-defined Variables

Name	Meaning	Data type	Description
_MC_ErrSta	Motion Control Error Status	WORD	Contains the error status of the Motion Control Function Module.*1

*1 Refer to the *NJ/NX-series CPU Unit Software User's Manual* (Cat. No. W501) or *NY-series Industrial Panel PC / Industrial Box PC Software User's Manual* (Cat. No. W558) for details.

Precautions for Correct Use

- The error may not be reset immediately after you execute this instruction. Use the GetMCErr instruction to confirm that the errors were reset.
- If you attempt to execute this instruction during an MC Test Run, the value of *Busy* remains TRUE and the instruction is not executed.
- If you execute this instruction for an OMRON G5-series Servo Drive, perform exclusive control of the instructions so that the ResetECErr instruction is not executed at the same time. If the ResetMCErr and ResetECErr instructions are executed at the same time, the G5-series Servo Drive will no longer accept SDO communications.

Version Information

- With a CPU Unit with unit version 1.02 to 1.09, you can create only 100 instances of this instruction.
- If you transfer a user program that has more than 100 instances of this instruction to a Controller with a CPU Unit with unit version 1.02 to 1.09, a Controller error will occur. The Controller error depends on the transfer method that is used for the user program as given below.

User program transfer method	Event code for Controller error	Level of Controller error
Project transferred with synchronization function	10250000 hex	Major fault level
	571D0000 hex	Observation
User program transferred with online editing	571D0000 hex	Observation

- If you transfer a user program that has more than 100 instances of this instruction to a Controller with a CPU Unit with unit version 1.01 or earlier, the above Controller error will not occur. However, if you create too many instances of this instruction, the user program will become too large and a major fault level Controller error will occur.

Sample Programming

This sample detects Controller errors in the EtherCAT Master Function Module and Motion Control Function Module. If errors are detected, they are reset. The processing procedure is as follows:

- 1** The GetECError instruction is executed to detect any Controller errors in the EtherCAT Master Function Module.
- 2** If errors are detected, they are reset with the ResetECError instruction.
- 3** The GetMCError instruction is executed to detect any Controller errors in the Motion Control Function Module.
- 4** If errors are detected, they are reset with the ResetMCError instruction.

LD

Variable	Data type	Initial value	Comment
Request	BOOL	FALSE	Error detection reset request
EC_Err_Level	UINT	0	Highest event level in EtherCAT Master Function Module
EC_Err_Code	DWORD	DWORD#16#0	Highest level event code in EtherCAT Master Function Module
EC_Operating	BOOL	FALSE	Resetting error in EtherCAT Master Function Module
MC_Err_Level	UINT	0	Highest event level in Motion Control Function Module
MC_Err_Code	DWORD	DWORD#16#0	Highest level event code in Motion Control Function Module
MC_Operating	BOOL	FALSE	Resetting error in Motion Control Function Module
Normal_End	BOOL	FALSE	Normal end
ResetECErr_instance	ResetECErr		
ResetMCErr_instance	ResetMCErr		

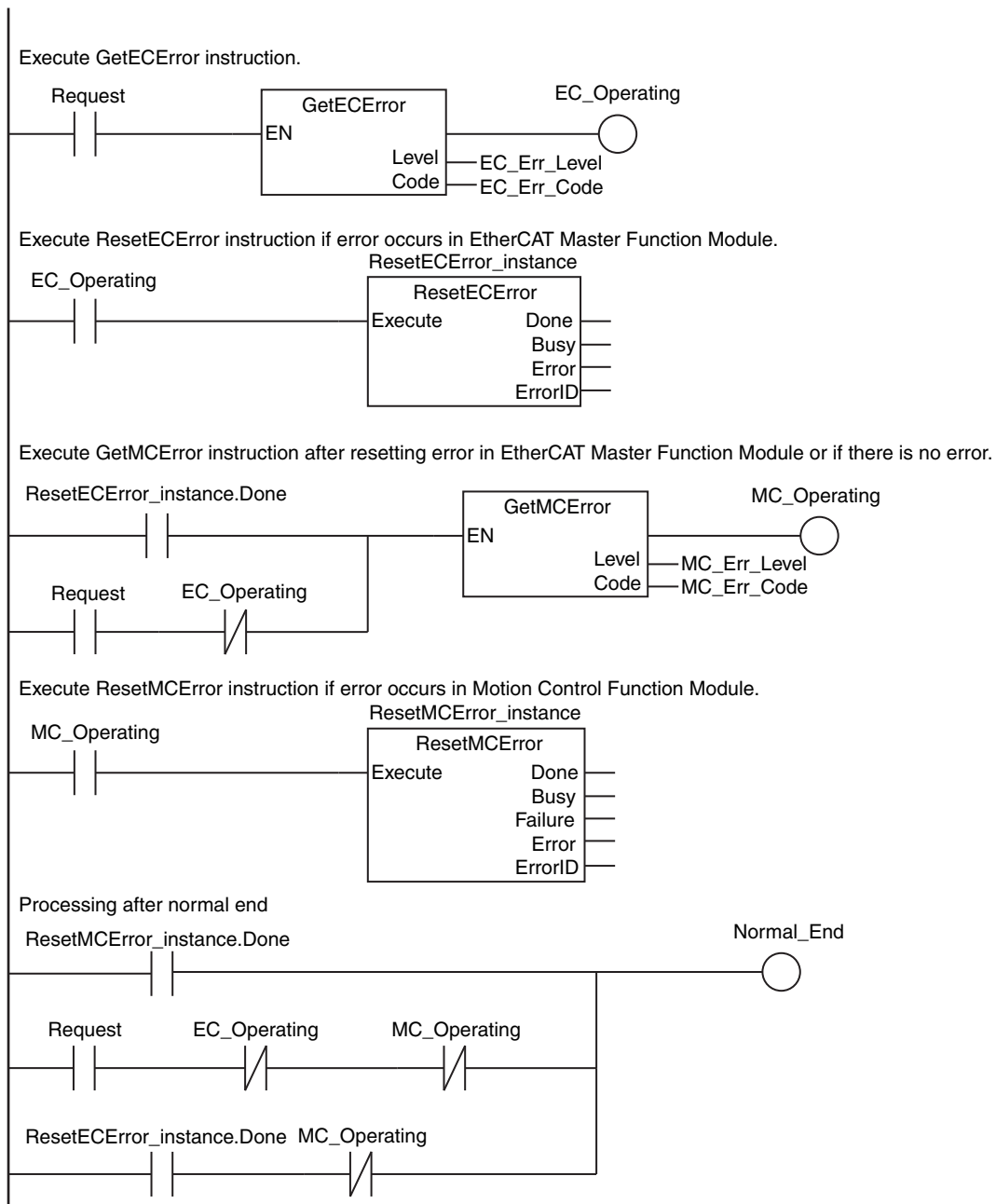

ST

Variable	Data type	Initial value	Comment
Request	BOOL	FALSE	Error detection reset request
EC_Error	BOOL	FALSE	Error in EtherCAT Master Function Module
EC_Err_Level	UINT	0	Highest event level in EtherCAT Master Function Module
EC_Err_Code	DWORD	DWORD#16#0	Highest level event code in EtherCAT Master Function Module
EC_Stage	INT	0	Error reset in EtherCAT Master Function Module
MC_Error	BOOL	FALSE	Error in Motion Control Function Module
MC_Err_Level	UINT	0	Highest event level in Motion Control Function Module
MC_Err_Code	DWORD	DWORD#16#0	Highest level event code in Motion Control Function Module
MC_Stage	INT	0	Error reset in Motion Control Function Module
ResetECError_instance	ResetECError		
ResetMCError_instance	ResetMCError		

```

IF (Request=TRUE) THEN // Determine error resetting requests.
  EC_Error:=GetECError(EC_Err_Level, EC_Err_Code); // Detect Controller errors in EtherCAT Master Function
                                                    // Module.
  MC_Error:=GetMCError(MC_Err_Level, MC_Err_Code); // Detect Controller errors in Motion Control Function
                                                    // Module.

  IF (EC_Error=TRUE) THEN // Controller error in EtherCAT Master Function Module.
    CASE EC_Stage OF
      0 : // Initialize
        ResetECError_instance(Execute:=FALSE);
        EC_Stage:=INT#1;
      1 : // Resetting Controller error in EtherCAT Master Function Module.
        ResetECError_instance(Execute:=TRUE);
        IF (ResetECError_instance.Done=TRUE) THEN
          EC_Stage:=INT#99; // Normal end
        END_IF;
        IF (ResetECError_instance.Error=TRUE) THEN
          EC_Stage:=INT#98; // Error end
        END_IF;
      99 : // Processing after normal end
        EC_Stage:=INT#0;
      98 : // Processing after error end.
        EC_Stage:=INT#0;
    END_CASE;
  END_IF;

  IF (MC_Error=TRUE) THEN // Controller error in Motion Control Function Module.
    CASE MC_Stage OF
      0 : // Initialize
        ResetMCError_instance(Execute:=FALSE);
        MC_Stage:=INT#1;
      1 : // Resetting Controller error in Motion Control Function Module.
        IF (EC_Error=FALSE) THEN // Recover operation for all slaves.
          ResetMCError_instance(Execute:=TRUE);
          IF (ResetMCError_instance.Done=TRUE) THEN
            MC_Stage:=INT#99; // Normal end
          END_IF;
          IF ( (ResetMCError_instance.Error=TRUE) OR (ResetMCError_instance.Failure=TRUE) ) THEN
            MC_Stage:=INT#98; // Error end
          END_IF;
        END_IF;
      99 : // Processing after normal end
        MC_Stage:=INT#0;
      98 : // Processing after error end.
        MC_Stage:=INT#0;
    END_CASE;
  END_IF;
END_IF;

```

GetMCErr

The GetMCErr instruction gets the highest level status (partial fault or minor fault) and highest level event code of the current Controller errors in the Motion Control Function Module.

Instruction	Name	FB/FUN	Graphic expression	ST expression
GetMCErr	Get Motion Control Error Status	FUN		Out:=GetMCErr(Level, Code);

Variables

Name	Meaning	I/O	Description	Valid range	Unit	Default
Out	Error flag	Output	TRUE: Controller error exists. FALSE: No Controller error	Depends on data type.	---	---
Level	Highest level status		Highest level status of all current Controller errors in the Motion Control Function Module 0: No Controller error 2: Partial fault level 3: Minor fault level	0, 2, or 3		
Code	Highest level event code		Highest level event code of all current Controller errors in the Motion Control Function Module 16#0000_0000: No Controller error 16#0007_0000 to 16#FFFF_FFFF: Event code	16#00000000 16#00070000 to 16#FFFFFFF		

	Boolean	Bit strings				Integers							Real numbers		Times, durations, dates, and text strings					
	BOOL	BYTE	WORD	DWORD	LWORD	USINT	UINT	UDINT	ULINT	SINT	INT	DINT	LINT	REAL	LREAL	TIME	DATE	TOD	DT	STRING
Out	OK																			
Level							OK													
Code				OK																

Function

The GetMCErr instruction gets the highest level status and the highest level event code of the current Controller errors in the Motion Control Function Module and outputs them to *Level* and *Code*. If there are currently no Controller errors, the value of error flag *Out* is FALSE. If there is more than one Controller error at the highest event level, the value of *Code* is the event code for the Controller error that occurred first.

The following figure shows a programming example.

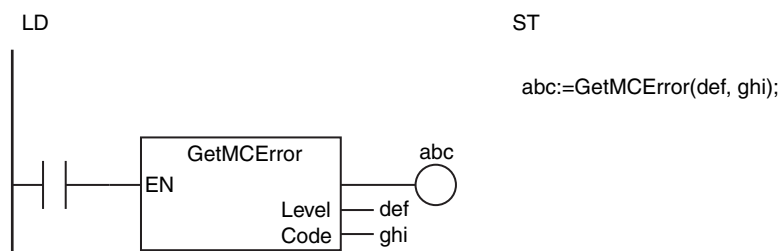

The GetMCErr instruction gets the highest level status and the highest level event code of the current Controller errors in the Motion Control Function Module and outputs them to *Level* and *Code*.

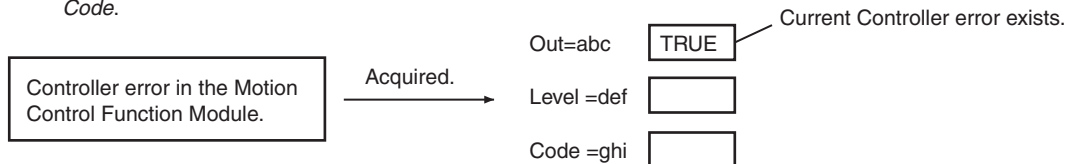

Related System-defined Variables

Name	Meaning	Data type	Description
_MC_ErrSta	Error Status of Motion Control Function Module	WORD	Contains the error status of the Motion Control Function Module.*1

*1 Refer to the *NJ/NX-series CPU Unit Software User's Manual* (Cat. No. W501) or *NY-series Industrial Panel PC / Industrial Box PC Software User's Manual* (Cat. No. W558) for details.

Sample Programming

Refer to the sample programming that is provided for the ResetMCErr instruction (page 2-828).

ResetECError

The ResetECError instruction resets a Controller error in the EtherCAT Master Function Module.

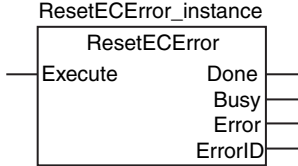
Instruction	Name	FB/FUN	Graphic expression	ST expression
ResetECError	Reset EtherCAT Error	FB		ResetECError_instance(Execute, Done, Busy, Error, ErrorID);

Variables

Only common variables are used.

Function

The ResetECError instruction resets Controller errors in the EtherCAT Master Function Module.

The following figure shows a programming example.

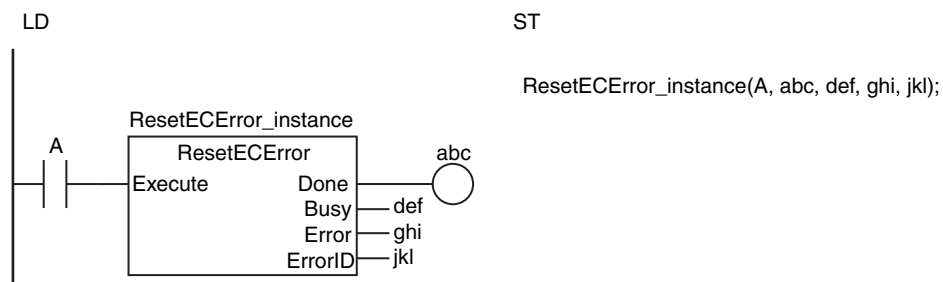

The ResetECError instruction resets a Controller error in the EtherCAT Master Function Module.



Related System-defined Variables

Name	Meaning	Data type	Description
_EC_ErrSta	Built-in EtherCAT Error	WORD	Contains a summary of the errors in the EtherCAT Master Function Module.*1

*1 Refer to the *NJ/NX-series CPU Unit Software User's Manual* (Cat. No. W501) or *NY-series Industrial Panel PC / Industrial Box PC Built-in EtherCAT Port User's Manual* (Cat. No. W562) for details.

Precautions for Correct Use

- The error may not be reset immediately after you execute this instruction. Use the GetECError instruction to confirm that the errors were reset.
- If you execute this instruction for an OMRON G5-series Servo Drive, perform exclusive control of the instructions so that the ResetMCError, MC_Reset, or MC_GroupReset instruction is not executed at the same time. If any of these three instructions and the ResetECError instruction are executed at the same time, the G5-series Servo Drive will no longer accept SDO communications.
- You cannot execute this instruction during execution of the following instructions: EC_DisconnectSlave, EC_ConnectSlave, EC_ChangeEnableSetting, ResetECError, RestartNXUnit, and NX_ChangeWriteMode.
- An error occurs in the following case. *Error* will change to TRUE.
 - This instruction is executed again while processing to clear a Controller error from the EtherCAT Master Function Module is in progress.
 - The EC_DisconnectSlave, EC_ConnectSlave, EC_ChangeEnableSetting, ResetECError, RestartNXUnit, or NX_ChangeWriteMode instruction is already in execution.

Sample Programming

Refer to the sample programming that is provided for the ResetMCError instruction (page 2-828).

GetECError

The GetECError instruction detects errors in the EtherCAT Master Function Module.

Instruction	Name	FB/FUN	Graphic expression	ST expression
GetECError	Get EtherCAT Error Status	FUN		Out:=GetECError(Level, Code);

Variables

Name	Meaning	I/O	Description	Valid range	Unit	Default
Out	Error flag	Output	TRUE: Error exists.* ¹ FALSE: No error	Depends on data type.		
Level	Highest level status		Status of the current error with the highest level* ¹ 0: No error 2: Partial fault level 3: Minor fault level	0, 2, or 3	---	---
Code	Highest level event code		Event code of the current error with the highest level* ¹	16#00000000 16#00070000 to 16#FFFFFFFF		

*¹ The errors that are detected depend on the unit version of the CPU Unit and the version of the Sysmac Studio. Refer to *Function* for details.

	Boolean	Bit strings				Integers							Real numbers		Times, durations, dates, and text strings					
	BOOL	BYTE	WORD	DWORD	LWORD	USINT	UINT	UDINT	ULINT	SINT	INT	DINT	LINT	REAL	LREAL	TIME	DATE	TOD	DT	STRING
Out	OK																			
Level							OK													
Code				OK																

Function

The GetECError instruction detects errors in the EtherCAT Master Function Module.

The value of *Out* is TRUE if there is an error and FALSE if there is no error.

Level gives the status of the current error with the highest level.

Code gives the event code of the current error with the highest level.

Detected Errors and Output Variable Values

The errors that are detected by this instruction depend on the unit version of the CPU Unit. The following table lists the errors that are detected for each unit version.

Unit version of CPU Unit	Detected errors
1.02 or later	Communications port errors, master errors, and slave errors
1.01 or earlier	Communications port errors and master errors

The following table shows the relationship between the unit version of the CPU Unit, the status of the EtherCAT Master Function Module, and the values of the output variables.

Unit version of CPU Unit	Status of EtherCAT Master Function Module	Value of <i>Out</i>	Value of <i>Level</i>	Value of <i>Code</i>
1.04 or later	No error	FALSE	0	16#0000_0000
	Communications port error or master error	TRUE	Status of the current error with the highest level 2: Partial fault level 3: Minor fault level	Event code of the current error with the highest level.*1 16#0007_0000 to 16#FFFF_FFFF
	Slave error			16#0000_0000
1.02 or 1.03	No error	FALSE	0	16#0000_0000
	Communications port error or master error	TRUE	Status of the current error with the highest level 2: Partial fault level 3: Minor fault level	Event code of the current error with the highest level.*1 16#0007_0000 to 16#FFFF_FFFF
	Slave error			FALSE
1.00 or 1.01	No error	FALSE	0	16#0000_0000
	Communications port error or master error	TRUE	Status of the current error with the highest level 2: Partial fault level 3: Minor fault level	Event code of the current error with the highest level.*1 16#0007_0000 to 16#FFFF_FFFF
	Slave error			FALSE

*1 If there is more than one error at the highest event level, the value of *Code* is the event code for the error that occurred first.

Notation Example

The following figure shows a programming example.

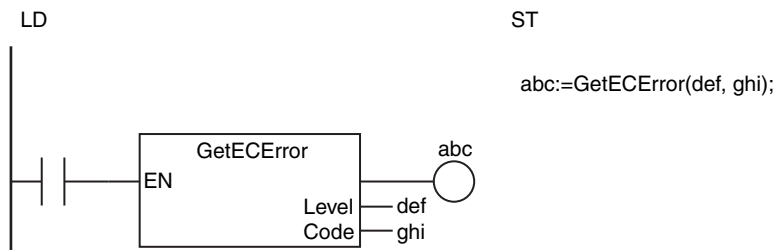

The GetECError instruction detects current communications port errors, master errors, and slave errors in the EtherCAT Master Function Module.

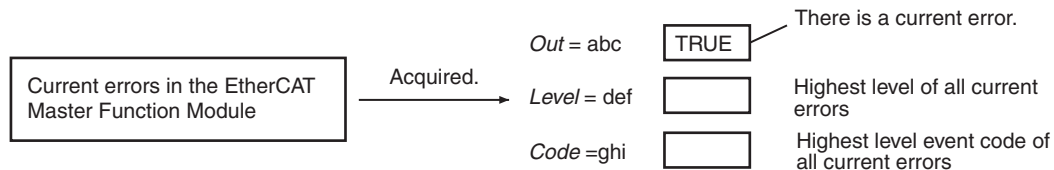

Related System-defined Variables

Name	Meaning	Data type	Description
_EC_ErrSta	Built-in EtherCAT Error	WORD	Contains a summary of the errors in the EtherCAT Master Function Module.*2
_EC_PortErr*1	Communications Port Error	WORD	Contains a summary of the EtherCAT master communications port errors.*2
_EC_MstrErr*1	Master Error	WORD	Contains a summary of the EtherCAT master errors and the slave errors detected by the EtherCAT master.*2
_EC_SlavErr	Slave Error	WORD	Contains a summary of the overall EtherCAT slave error status.*2

*1 The GetECError instruction gets the errors that are shown by _EC_PortErr (Communications Port Error) and _EC_MstrErr (Master Error).

*2 Refer to the *NJ/NX-series CPU Unit Built-in EtherCAT Port User's Manual* (Cat. No. W505) or *NY-series Industrial Panel PC / Industrial Box PC Built-in EtherCAT Port User's Manual* (Cat. No. W562) for details.

Precautions for Correct Use



Version Information

A CPU Unit with unit version 1.02 or later is required to detect slave errors with this instruction.

Sample Programming

Refer to the sample programming that is provided for the ResetMCErr instruction (page 2-828).

ResetNXBError

The ResetNXBError instruction resets the current Controller errors in the NX Bus Function Module.

Instruction	Name	FB/ FUN	Graphic expression	ST expression
ResetNXBError	Reset NX Bus Error	FB		ResetNXBError_instance(Execute, Done, Busy, Error, ErrorID);



Precautions for Correct Use

You can use this instruction for the NX1P2 CPU Unit only.

Variables

Only common variables are used.

Function

The ResetNXBError instruction resets the current Controller errors in the NX Bus Function Module.

After an error is reset, the *Busy* output variable changes to FALSE and the *Done* output variable changes to TRUE.

For Safety Control Units, however, errors are not reset.

If this instruction is executed again in a different instance from the instance for which error reset processing is in progress, the latter instruction will result in an error.

The *Error* output variable of the latter command changes to TRUE and the error code (Multi-execution of Instructions: 041A) is output to the *ErrorID* output variable.

Related System-defined Variables

Name	Meaning
_NXB_ErrSta	NX Bus Function Module Error Status

Additional Information

- If you execute this instruction in the Simulator, when *Execute* changes from FALSE to TRUE, *Done* changes to TRUE, *Busy* changes to FALSE, *Error* changes to FALSE, and *ErrorID* changes to 0. And, errors will not be cleared.
- If the cause of the error is not solved and the error status remains after resetting an error, the error reset may appear to be impossible.

- The event log is not cleared.

Precautions for Correct Use

You cannot use this instruction in an event task. A compiling error will occur.

GetNXBError

The GetNXBError instruction gets the highest level status of all current Controller errors in the NX Bus Function Module of the NX-series CPU Unit.

Instruction	Name	FB/ FUN	Graphic expression	ST expression
GetNXBError	Get NX Bus Error Status	FUN		<pre>Out:=GetNXBError(UnitProxy, Level);</pre>



Precautions for Correct Use

You can use this instruction for the NX1P2 CPU Unit only.

Variables

Name	Meaning	I/O	Description	Valid range	Unit	Default
Out	Error flag	Output	TRUE: Error exists. FALSE: No error	Depends on data type.	---	---
UnitProxy	Lower level NX Unit		NX Unit where the status of the current error is <i>Level</i>	---		
Level	Highest level status		Status of the current error with the highest level 0: No error 2: Partial fault level 3: Minor fault level	0, 2, or 3		

	Boolean	Bit strings					Integers							Real numbers	Times, durations, dates, and text strings					
	BOOL	BYTE	WORD	DWORD	LWORD	USINT	UINT	UDINT	ULINT	SINT	INT	DINT	LINT	REAL	LREAL	TIME	DATE	TOD	DT	STRING
Out	OK																			
UnitProxy	Refer to <i>Function</i> for details on the structure <code>_sNXUNIT_ID</code> .																			
Level							OK													

Function

The GetNXBError instruction gets the highest level status (partial fault or minor fault) of the current Controller errors in the NX Bus Function Module.

This instruction applies to the NX1P2 CPU Unit and NX Unit connected to the NX bus on the CPU Unit.

The value of *Out* is TRUE if there is an error and FALSE if there is no error.

Level gives the status of the current error with the highest level.

UnitProxy returns the *UnitProxy* of the NX Unit where the status of the current error is *Level*.

If errors of the same level occur in more than one Unit, it returns *UnitProxy* of the NX Unit that is closest to the master and has the lowest unit number.

The data type of *UnitProxy* is structure `_sNXUNIT_ID`. The specifications are as follows:

Name	Meaning	Description	Data type
UnitProxy	Lower level NX Unit	NX Unit where the status of the current error is <i>Level</i>	<code>_sNXUNIT_ID</code>
NodeAdr	Node address	Node address of the Communications Coupler Unit	UINT
IPAdr	IP address	IP address of the Communications Coupler Unit	BYTE[5]
UnitNo	Unit number	Unit number of the NX Unit	UDINT
Path	Path	Path information to the NX Unit	BYTE[64]
PathLength	Valid path length	Valid path length	USINT

Pass a `_sNXUNIT_ID` structure variable that is created in the variable table to *UnitProxy*.

Related System-defined Variables

Name	Meaning
<code>_NXB_ErrSta</code>	NX Bus Function Module Error Status
<code>_NXB_MstrErrSta</code>	NX Bus Function Module Master Error Status
<code>_NXB_UnitErrSta[1] to [63]</code>	NX Bus Function Module Unit Error Status

Additional Information

- If you execute this instruction in the Simulator, this instruction always returns No error, and *Out* changes to FALSE, *Level* changes to 0, and the value of *UnitProxy* is undefined.

GetNXUnitError

The GetNXUnitError instruction gets the highest level status and highest level event code of the current Controller errors in the NX Bus Function Module of the NX-series CPU Unit or NX Units.

Instruction	Name	FB/ FUN	Graphic expression	ST expression
GetNXUnitError	Get NX Unit Error Status	FB		<pre>GetNXUnitError_instance(Execute, UnitProxy, TimeOut, Done, Busy, Error, ErrorID, ErrorIDEx, Level, Code)</pre>



Precautions for Correct Use

You can use this instruction for the NX1P2 CPU Unit only.

Variables

Name	Meaning	I/O	Description	Valid range	Unit	Default
UnitProxy	Specified Unit	Input	Specifies the target NX Unit.	---	---	*1
TimeOut	Timeout time		2.0 s when the timeout time is set to 0	0 to 60000	ms	2000 (2.0 s)
Level	Highest level status	Output	Status of the current error with the highest level 0: No error 2: Partial fault level 3: Minor fault level	0, 2, or 3	---	---
Code	Highest level event code		Highest level event code of all the current errors	16#00000000 16#00070000 to 16#FFFFFFFF		

*1 If you omit an input parameter, the default value is not applied. A building error will occur.

	Boolean	Bit strings				Integers							Real numbers		Times, durations, dates, and text strings					
	BOOL	BYTE	WORD	DWORD	LWORD	USINT	UINT	UDINT	ULINT	SINT	INT	DINT	LINT	REAL	LREAL	TIME	DATE	TOD	DT	STRING
UnitProxy	Refer to <i>Function</i> for details on the structure <code>_sNXUNIT_ID</code> .																			
TimeOut							OK													
Level							OK													
Code				OK																

Function

The GetNXUnitError instruction outputs the highest level status (partial fault or minor fault) and highest level event code of the current Controller errors in the NX Bus Function Module and NX Units, as well as the lower level NX Units from which to get the data.

This instruction applies to the NX1P2 CPU Unit and NX Unit connected to the NX bus on the CPU Unit.

The Unit from which to get data is specified with *UnitProxy*.

The instruction finishes getting data when the value of *Done* changes to TRUE.

The data type of *UnitProxy* is structure `_sNXUNIT_ID`. The specifications are as follows:

Name	Meaning	Description	Data type
UnitProxy	Specified Unit	Specified Unit	<code>_sNXUNIT_ID</code>
NodeAdr	Node address	Node address of the Communications Coupler Unit	UINT
IPAdr	IP address	IP address of the Communications Coupler Unit	BYTE[5]
UnitNo	Unit number	Unit number of the specified Unit	UDINT
Path	Path	Path information to the specified Unit	BYTE[64]
PathLength	Valid path length	Valid path length	USINT

Pass a device variable that is assigned to the specified Unit to *UnitProxy*.

TimeOut specifies the timeout time. If a response does not return within the timeout time, it judges that communications failed.

Level gives the status of the current error with the highest level.

Code gives the event code of the current error with the highest level. If errors of the same level occur in more than one Unit, it gives the oldest event code. If there is no error, it gives 16#00000000.

Specified NX Unit and Variable Values

The values output to in-out and output variables vary depending on the specified NX Unit.

The relationship between the specified NX Unit and the value of each variable is shown in the following table.

Specified Unit	NX1P2 CPU Unit	NX Unit on CPU Unit
Value of <i>Level</i>	Highest level status of CPU Unit	Highest level status of NX Unit
Value of <i>Code</i>	If there are more than one error: Highest level event code If there are more than one error in the same level: Oldest event code If there is no error: 16#0000_0000	

Combined Use with the GetNXBError Instruction

In the user program, normally use the GetNXBError (Get NX Bus Error Status) instruction to monitor if there are errors on the NX bus.

When the *Level* output variable of the GetNXBError instruction is other than 0, the value that indicates the NX Unit with the highest event level is stored in *UnitProxy* of the instruction.

To get *Level* and *Code* of the NX Unit where the error occurred, execute the GetNXUnitError instruction.

Related System-defined Variables

Name	Meaning
_NXB_UnitErrFlagTbl	NX Unit Error Status

Additional Information

Parameters That You Need Pass to *UnitProxy*

The following describes the parameters that you need to pass to the *UnitProxy* input variable.

- **Using Only the User Program to Pass Parameters to *UnitProxy***

Pass *ErrorUnit* which is the value of *UnitProxy* that you get from the GetNXBError instruction sent to the NX Bus Function Module.

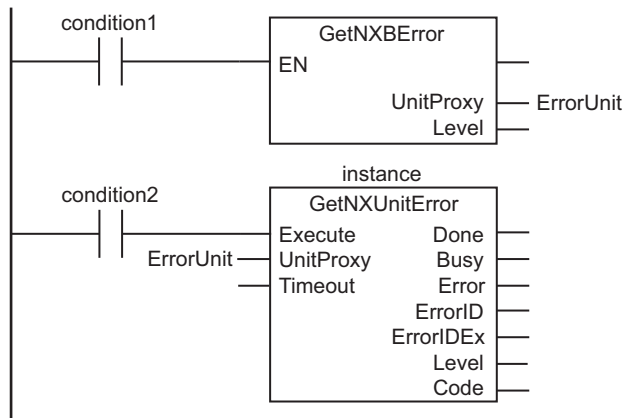

- **Using the Device Variable to Pass Parameters to *UnitProxy***

Create a device variable that specifies the Unit on the NX bus and pass it to *UnitProxy* of this instruction.

External variables	Variable	Data type	Constant	Comment
	N1_Node_location_information	_sNXUNIT_ID	<input checked="" type="checkbox"/>	

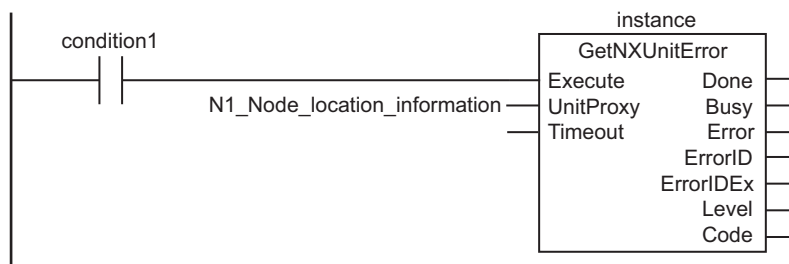

Run in the Simulator

If you run this instruction in the Simulator, the result when *Execute* changes from FALSE to TRUE is as shown in the table below.

Output variable	Meaning
Done	TRUE
Busy	FALSE
Error	FALSE
ErrorID	0

Output variable	Meaning
ErrorIDEx	0
Level	0
Code	0

Precautions for Correct Use

- Execution of this instruction is continued until processing is completed even if the value of *Execute* changes to FALSE or the execution time exceeds the task period. The value of *Done* changes to TRUE when processing is normally completed. Use this to confirm normal completion of processing.
- Refer to *Using this Section* on page 2-3 for a timing chart for *Execute*, *Done*, *Busy*, and *Error*.
- A compiling error will occur if you use this instruction in an event task. Do not use this instruction in event tasks.
- You cannot execute this instruction more than once at the same time. Only one instance can be executed at a time.
- Error is TRUE if an error occurred. The meanings of the values of *ErrorID* and *ErrorIDEx* are given in the following table.

Value of <i>ErrorID</i>	Value of <i>ErrorIDEx</i>	Description
16#0400	16#00000000	<ul style="list-style-type: none"> • The value of <i>UnitProxy</i> is outside of the valid range. • The value of <i>TimeOut</i> is outside of the valid range.
16#041A	16#00000000	While this instruction was being executed, it was executed again.
16#2C00	16#00000401	The specified Unit does not support the instruction.
	16#00001001 16#00001002 16#00170000 16#00200000 16#00210000	An input parameter, output parameter, or in-out parameter is incorrect. Confirm that the intended parameter is used for the input parameter, output parameter, or in-out parameter.
	16#00001010	The data size of the specified NX object does not agree with the data size specified in <i>WriteDat</i> .
	16#00001101	The Unit is not correct. Check the Unit.
	16#0000110B	The size of the read data is too large. Make sure that the read data specification is correct.
	16#00001110	There is no object that corresponds to the value of <i>Obj.Index</i> .
	16#00001111	There is no object that corresponds to the value of <i>Obj.Subindex</i> .
	16#00002101	The specified NX object cannot be written.
	16#00002110	The value of <i>WriteDat</i> exceeds the range of the values of the NX object to write.
	16#00002210	The specified Unit is not in a mode that allows writing data.
	16#00002213	Instruction execution was not possible because the specified Unit was performing an I/O check. Execute the instruction after the I/O check is completed.
	16#00002230	<p>The status of the specified Unit does not agree with the value of the read source or write destination NX object. Take the following actions if the value of <i>Obj.Index</i> is between 0x6000 and 0x6FFF or between 0x7000 and 0x7FFF.</p> <ul style="list-style-type: none"> • Delete the read source or write designation NX object from the I/O allocation settings. • Reset the error for the specified Unit. • Place the specified Unit in a mode that does not allow writing data.

Value of ErrorID	Value of ErrorIDEx	Description
16#2C00	16#00002231	Instruction execution was not possible because the specified Unit was performing initialization. Wait for the Unit to start normal operation and then execute the instruction.
	16#0000250F	Hardware access failed. Execute the instruction again.
	16#00002601 16#00002602 16#00100000	The specified Unit does not support this instruction. Check the version of the Unit.
	16#00002603	Execution of the instruction failed. Execute the instruction again. Make sure that at least one channel is enabled in the selections of the channels to use.
	16#00002621	The NX Unit is not in a status in which it can acknowledge the instruction. Wait for a while and then execute the instruction again.
	16#00010000	The specified Unit does not exist. Make sure that the Unit configuration is correct.
	16#00110000	The specified port number does not exist. Make sure that the Unit configuration is correct.
	16#00120000 16#00130000 16#00150000 16#00160000	The value of <i>UnitProxy</i> is not correct. Set the variable that indicates the specified EtherCAT Coupler Unit again.
	16#00140000	The specified node address is not correct. Make sure that the Unit configuration is correct.
	16#00300000 16#80010000	The specified Unit is busy. Execute the instruction again.
	16#00310000	The specified Unit is not supported for connection. Check the version of the Unit.
	16#80000000 16#80050000 16#81010000 16#81020000 16#82020000 16#82030000 16#82060000 to 16#8FFF0000 16#90010000 to 16#FFFE0000	An error occurred in the communications network. Execute the instruction again.
	16#80020000 16#80030000 16#81030000 16#82000000	An error occurred in the communications network. Reduce the amount of communications traffic.
	16#80040000 16#81000000 16#82010000 16#82040000 16#82050000 16#90000000	An error occurred in the communications network. Check the Unit and cable connections. Make sure that the power supply to the Unit is ON.
	16#2C02	16#00000000

Sample Programming

This sample passes the Unit, level, and code values to variables for display on a touch panel if an error occurs on the NX bus.

The system configuration is as shown below.

Assume that three NX Units are connected to an NX1P2 CPU Unit.

Device Variables

NX Units	Device variable
1st NX Unit	N1_Node_location_information
2nd NX Unit	N2_Node_location_information
3rd NX Unit	N3_Node_location_information

Definitions of Global Variables

Global Variables

Variable	Data type	Constant	Comment
N1_Node_location_information	_sNXUNIT_ID	<input checked="" type="checkbox"/>	
N2_Node_location_information	_sNXUNIT_ID	<input checked="" type="checkbox"/>	
N3_Node_location_information	_sNXUNIT_ID	<input checked="" type="checkbox"/>	
HMI_Level*1	UINT	<input type="checkbox"/>	
HMI_Code*1	DWORD	<input type="checkbox"/>	
HMI_Unit*1	UDINT	<input type="checkbox"/>	

*1 The variables that begin with HMI are variables for display on a touch panel .

Internal variables	Variable	Data type	Constant	Comment
	instance	GetNXUnitError	<input type="checkbox"/>	
	ErrorOccurred	BOOL	<input type="checkbox"/>	
	ErrorUnit	_sNXUNIT_ID	<input type="checkbox"/>	
	DummyLowerUnit	_sNXUNIT_ID	<input type="checkbox"/>	

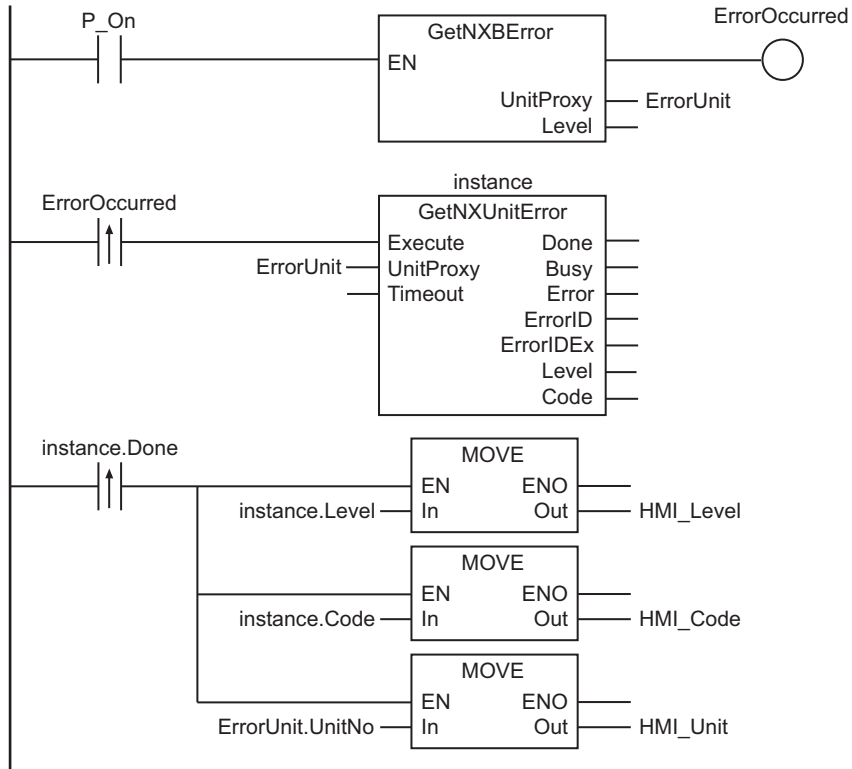

SetInfo

The SetInfo instruction creates user-defined information.

Instruction	Name	FB/FUN	Graphic expression	ST expression
SetInfo	Create User-defined Information	FUN		SetInfo(Code, Info1, Info2);

Variables

Name	Meaning	I/O	Description	Valid range	Unit	Default
Code	Event code	Input	Event code of user-defined information to generate	40001 to 60000	---	40001
Info1	Attached information 1		Values recorded in event log when the user-defined information is generated	Depends on data type.		*
Info2	Attached information 2					
Out	Return value	Output	Always TRUE	TRUE only	---	---

* If you omit the input parameter, the default value is not applied. A building error will occur.

	Boolean	Bit strings					Integers							Real numbers	Times, durations, dates, and text strings					
	BOOL	BYTE	WORD	DWORD	LWORD	USINT	UINT	UDINT	ULINT	SINT	INT	DINT	LINT	REAL	LREAL	TIME	DATE	TOD	DT	STRING
Code							OK													
Info1	OK	OK	OK	OK	OK	OK	OK	OK	OK	OK	OK	OK	OK	OK	OK	OK	OK	OK	OK	
Info2	OK	OK	OK	OK	OK	OK	OK	OK	OK	OK	OK	OK	OK	OK	OK	OK	OK	OK	OK	
Out	OK																			

Function

The SetInfo instruction generates the user-defined information specified by event code *Code*. The time of occurrence, event code *Code*, event level, attached information *Info1*, and attached information *Info2* are stored in the user event log area that corresponds to the level of the event code.

The following figure shows a programming example. User-defined information for event code 40001 is generated. The values of variables *abc* and *def* are stored as attached information.

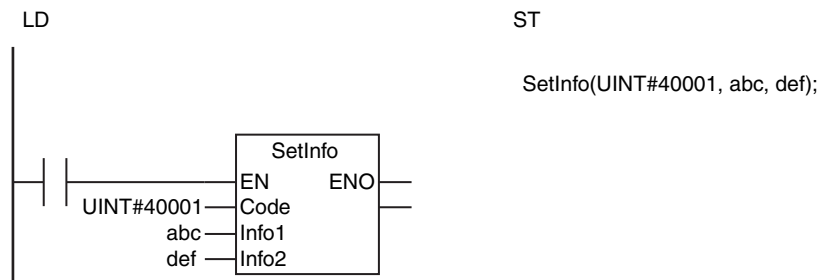

The SetInfo instruction generates the user-defined information specified by event code *Code*. Also, the time of occurrence, event code *Code*, event level, attached information *Info1*, and attached information *Info2* are stored in the user event log area that corresponds to the level of the event code.

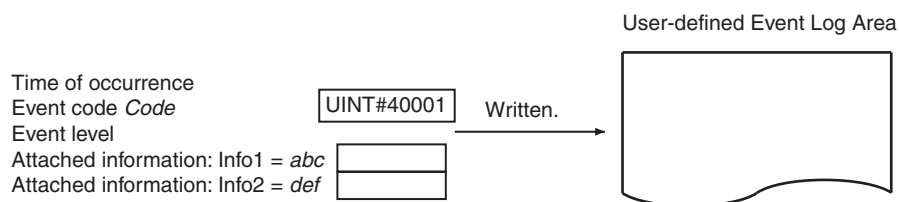
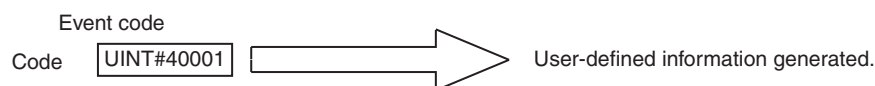

Precautions for Correct Use

- Always use variables for the input parameters that are passed to *Info1* and *Info2*. If the attached information is not used, specify a dummy variable. A building error will occur if a constant is specified.
- Return value *Out* is not used when the instruction is used in ST.
- An error occurs in the following case. *ENO* will be FALSE.
 - The value of *Code* is outside of the valid range.

ResetUnit

The ResetUnit instruction restarts a CPU Bus Unit or Special I/O Unit.

Instruction	Name	FB/FUN	Graphic expression	ST expression
ResetUnit	Restart Unit	FB	<pre> ResetUnit_instance ResetUnit Execute Done UnitNo Busy Error ErrorID </pre>	ResetUnit_instance(Execute, UnitNo, Done, Busy, Error, ErrorID);



Precautions for Correct Use

You cannot use this instruction in an NX-series CPU Unit.

Variables

Name	Meaning	I/O	Description	Valid range	Unit	Default
UnitNo	Unit number	Input	Unit number of Unit to restart	_CBU_No00 to _CBU_No15, _SIO_No00 to _SIO_No95	---	_CBU_No00

	Boolean	Bit strings					Integers							Real numbers	Times, durations, dates, and text strings						
		BOOL	BYTE	WORD	DWORD	LWORD	USINT	UINT	UDINT	ULINT	SINT	INT	DINT		LINT	REAL	LREAL	TIME	DATE	TOD	DT
UnitNo		Refer to <i>Function</i> for the enumerators of enumeration type _eUnitNo.																			

Function

The ResetUnit instruction restarts a CPU Bus Unit or Special I/O Unit.

The Unit to restart is specified by *UnitNo*.

The data type of *UnitNo* is enumerated type _eUnitNo. The meanings of the enumerators are as follows:

Enumerators	Meaning
_CBU_No00 to _CBU_No15	Unit number of CPU Bus Unit, 00 to 15
_SIO_No00 to _SIO_No95	Unit number of Special I/O Unit, 00 to 95

The following example is for when *UnitNo* is `_CBU_No00`. CPU Bus Unit with unit number 0 is restarted.

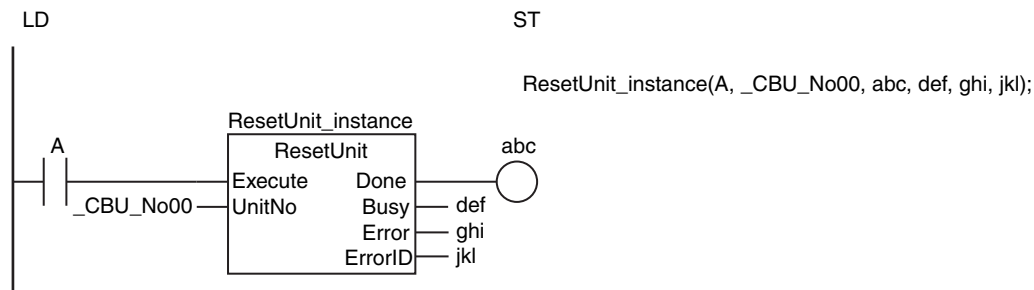

The `ResetUnit` instruction restarts the CPU Bus Unit or Special I/O Unit with *UnitNo*.

UnitNo = `_CBU_No00`: CPU Bus Unit with unit number 0 is restarted.

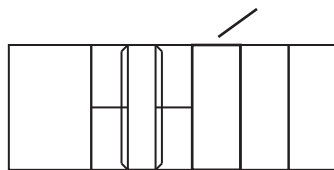

Precautions for Correct Use

- This instruction will not end in an error even if restart processing is in progress for the Unit specified by *UnitNo*. The value of *Busy* remains at TRUE and the value of *Done* changes to TRUE when restart processing is finished. Restart requests are not queued.
- The Unit is restarted if the value of *Execute* is TRUE when operation starts.
- An error occurs in the following cases. *Error* will change to TRUE.
 - The value of *UnitNo* is outside of the valid range.
 - The Unit specified with *UnitNo* does not exist.
 - Restart processing failed.

Sample Programming

When the value of *Trigger* changes to TRUE, the baud rate of serial port 1 on the Serial Communications Unit with a unit number of 0 is set to 38,400 bps and the Unit is restarted.

Definitions of Global Variables

Global Variables

Name	Data type	Initial value	AT	Retain	Comment
SCU_P1_BaudrateCfg	USINT	0	I/OBus://rack#0/slot#0 /P1_BaudrateCfg	✓	Baud rate

LD

Internal Variables	Variable	Data type	Initial value	Comment
	OperatingEnd	BOOL	FALSE	Processing completed
	Trigger	BOOL	FALSE	Execution condition
	Operating	BOOL	FALSE	Processing
	RS_instance	RS		
	ResetUnit_instance	ResetUnit		

External Variables	Variable	Data type	Comment
	SCU_P1_BaudrateCfg	USINT	Baud rate

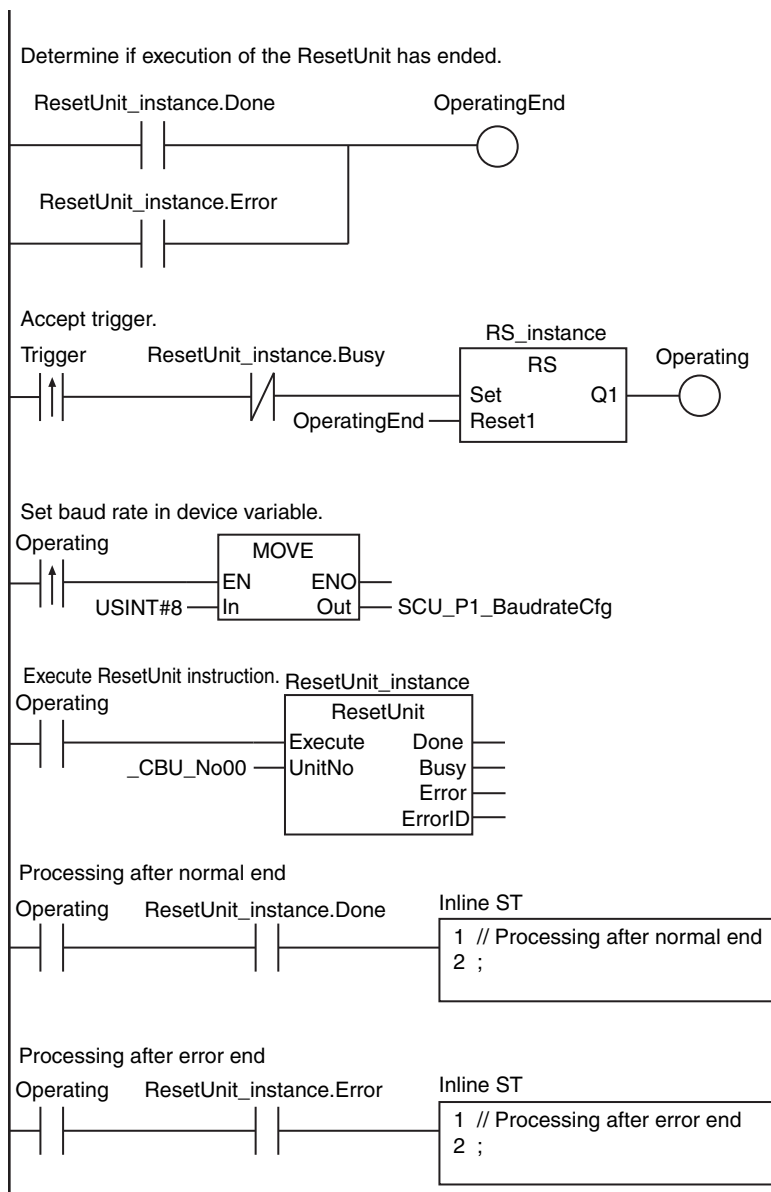

ST

Internal Variables	Variable	Data type	Initial value	Comment
	Trigger	BOOL	FALSE	Execution condition
	LastTrigger	BOOL	FALSE	Value of <i>Trigger</i> from previous task period
	OperatingStart	BOOL	FALSE	Processing started
	Operating	BOOL	FALSE	Processing
	ResetUnit_instance	ResetUnit		

External Variables	Variable	Data type	Comment
	SCU_P1_BaudrateCfg	USINT	Baud rate

```

// Detect when Trigger changes to TRUE.
IF ( (Trigger=TRUE) AND (LastTrigger=FALSE) AND (ResetUnit_instance.Busy=FALSE) ) THEN
    OperatingStart:=TRUE;
    Operating      :=TRUE;
END_IF;
LastTrigger:=Trigger;

// Initialize ResetUnit_instance and set baud rate in device variable.
IF (OperatingStart=TRUE) THEN
    ResetUnit_instance(Execute:=FALSE);
    SCU_P1_BaudrateCfg:=USINT#8;
    OperatingStart    :=FALSE;
END_IF;

// Execute ResetUnit instruction.
IF (Operating=TRUE) THEN
    ResetUnit_instance(
        Execute :=TRUE,          // Execution condition
        UnitNo  :=_CBU_No00); // Unit number

    IF (ResetUnit_instance.Done=TRUE) THEN
        // Processing after normal end
        Operating:=FALSE;
    END_IF;

    IF (ResetUnit_instance.Error=TRUE) THEN
        // Processing after error end
        Operating:=FALSE;
    END_IF;
END_IF;

```

GetNTPStatus

The GetNTPStatus instruction reads the NTP status.

Instruction	Name	FB/FUN	Graphic expression	ST expression
GetNTPStatus	Read NTP Status	FUN		GetNTPStatus(ExecTime, ExecNormal);

Variables

Name	Meaning	I/O	Description	Valid range	Unit	Default
Out	Return value	Output	Always TRUE	TRUE only	---	---
ExecTime	NTP last normal operation time		NTP last normal operation time	Depends on data type.	Year, month, day, hour, minutes, seconds	
Exec Normal	NTP normal end flag		TRUE: Normal end FALSE: Error end		---	

	Boolean	Bit strings					Integers							Real numbers		Times, durations, dates, and text strings				
	BOOL	BYTE	WORD	DWORD	LWORD	USINT	UINT	UDINT	ULINT	SINT	INT	DINT	LINT	REAL	LREAL	TIME	DATE	TOD	DT	STRING
Out	OK																			
ExecTime																			OK	
Exec Normal	OK																			

Function

The GetNTPStatus instruction reads the NTP status. The following information is read: *ExecTime* (NTP last normal operation time) and *ExecNormal* (NTP normal end flag).

The following figure shows a programming example.

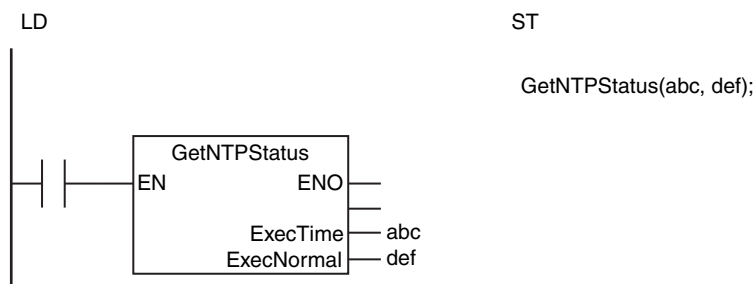

The GetNTPStatus instruction reads the NTP status.
The values of *ExecTime* and *ExecNormal* will be as follows when the last normal NTP operation was at 00:00.00 on July 7, 2011.

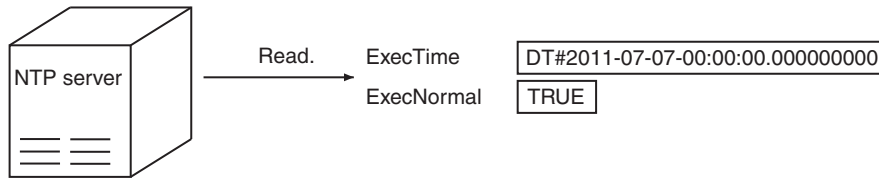

Related System-defined Variables

Name	Meaning	Data type	Description
_EIP_NTPResult	NTP Status	*1	Contains the NTP status.*2

*1 `_sNTP_RESULT`

*2 Refer to the *NJ/NX-series CPU Unit Software User's Manual* (Cat. No. W501) for details.

Precautions for Correct Use

- *Out* (Return value) is not used when the instruction is used in ST.
- This instruction reads the contents of the `_EIP_NTPResult` system-defined variable. You cannot access this variable directly. Always use this instruction to read the contents of the variable.

RestartNXUnit

The RestartNXUnit instruction restarts an EtherCAT Coupler Unit or NX Unit.

Instruction	Name	FB/FUN	Graphic expression	ST expression
RestartNXUnit	Restart NX Units	FB		RestartNXUnit_instance(Execute, UnitProxy, Done, Busy, Error, ErrorID, ErrorIDEx);

Variables

Name	Meaning	I/O	Description	Valid range	Unit	Default
UnitProxy	Specified Unit	Input	A Unit to restart: EtherCAT Coupler Unit, NX Bus Function Module or NX Unit	---	---	*

* If you omit the input parameter, the default value is not applied. A building error will occur.

	Boolean	Bit strings					Integers							Real numbers		Times, durations, dates, and text strings				
	BOOL	BYTE	WORD	DWORD	LWORD	USINT	UINT	UDINT	ULINT	SINT	INT	DINT	LINT	REAL	LREAL	TIME	DATE	TOD	DT	STRING
UnitProxy		Refer to <i>Function</i> for details on the structure <code>_sNXUNIT_ID</code> .																		

Function

The RestartNXUnit instruction restarts an EtherCAT Coupler Unit or an NX Unit on the EtherCAT Coupler Unit, and an NX Unit connected to the NX bus on the NX Bus Function Module or on the CPU Unit. You can use it to restart a specified Unit independently.

However, you cannot restart an EtherCAT Coupler Unit or NX Bus Function Module independently. If you specify an EtherCAT Coupler Unit or NX Bus Function Module, all of the NX Units that are connected to it are also restarted.

The Unit to restart is specified with *UnitProxy*.

The data type of *UnitProxy* is structure `_sNXUNIT_ID`. The meanings of the members are as follows:

Name	Meaning	Content	Data type
UnitProxy	Specified Unit	Specified Unit	<code>_sNXUNIT_ID</code>
NodeAdr	Node address	Node address of the Communications Coupler Unit	UINT
IPAdr	IP address	IP address of the Communications Coupler Unit	BYTE[5]
UnitNo	Unit number	Unit number of specified Unit	UDINT
Path	Path	Path information to the specified Unit	BYTE[64]
PathLength	Valid path length	Valid path length	USINT

Pass a device variable that is assigned to the specified EtherCAT Coupler Unit or an NX Unit on the EtherCAT Coupler Unit, and an NX Unit connected to the NX bus on the NX Bus Function Module or on the CPU Unit to *UnitProxy*.

Notation Example

The following example shows a case of restarting all EtherCAT Slave Terminals. A variable that is named 'ECAT1' with a data type of `_sNXUNIT_ID` is assigned to the EtherCAT Coupler Unit.

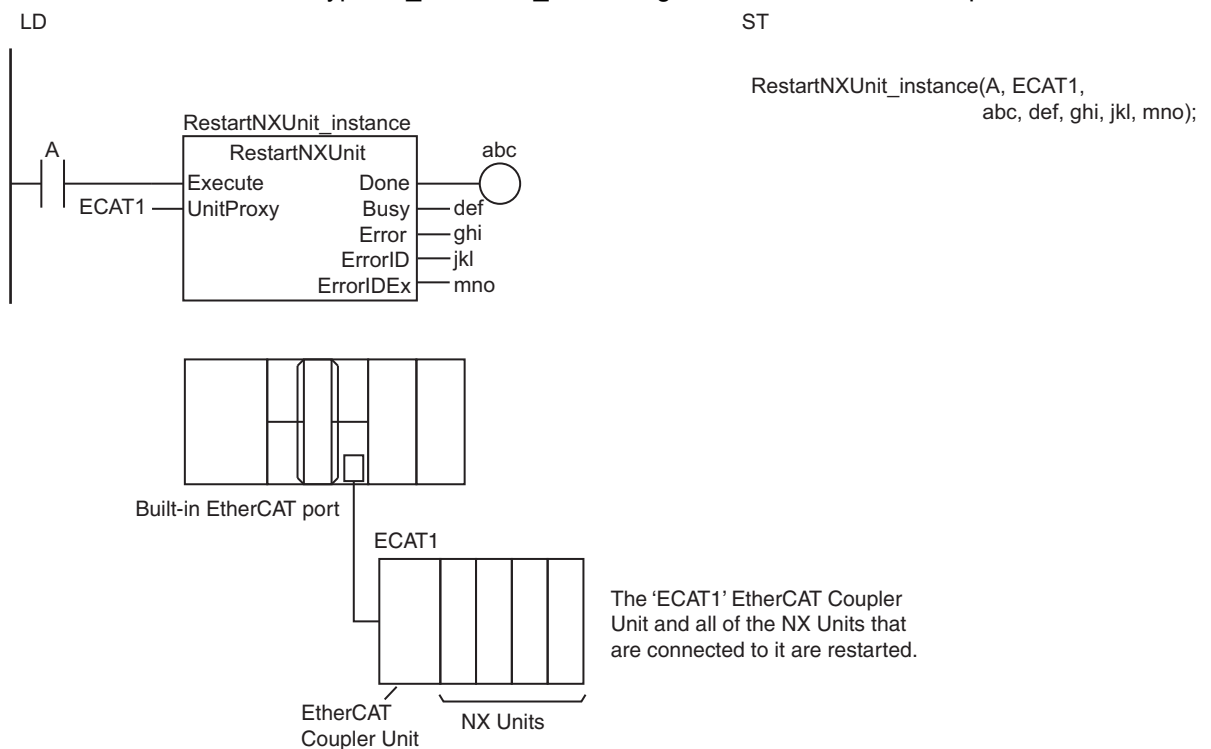

Related System-defined Variables

Name	Meaning	Data type	Description
_EC_MBXSlaVTbl[i] “i” is the node address.	Message Communications Enabled Slave Table	BOOL	This variable indicates whether communications are possible for each slave. TRUE: Communications are possible. FALSE: Communications are not possible.
_NXB_UnitMsgActiveTbl [i]	NX Unit Message Enabled Status	BOOL	This table indicates the slaves that can perform message communications. Use this variable to confirm that communications with the relevant slave are possible.

Additional Information

You can use the following procedure to write data with the following attributes to an EtherCAT Coupler Unit, an NX Unit on the EtherCAT Coupler Unit, or an NX Unit connected to the NX bus of the CPU Unit.

- Power OFF Retain attribute
 - The values are updated when the Unit is restarted.
- 1** Use the NX_ChangeWriteMode instruction (page 2-866) to change the Unit to a mode that allows writing data.
 - 2** Use the NX_WriteObj instruction (page 2-972) to write data to the Unit.
 - 3** Use the NX_SaveParam instruction (page 2-871) to save the data that you wrote.
 - 4** Use the RestartNXUnit instruction to restart the Unit.

Precautions for Correct Use

- Execution of this instruction is continued until processing is completed even if the value of *Execute* changes to FALSE or the execution time exceeds the task period. The value of *Done* changes to TRUE when processing is completed. Use this to confirm normal completion of processing.
- Refer to *Using this Section* (page 2-3) for a timing chart for *Execute*, *Done*, *Busy*, and *Error*.
- If you specify a Unit that is assigned to a motion control axis (data type *_sAXIS_REF*) for *UnitProxy*, a Controller error will occur in the Motion Control Function Module. Use the ResetMCError instruction (page 2-828) to reset the Controller error.
- For *UnitProxy*, specify the device variable that is assigned to an EtherCAT Coupler Unit or an NX Unit on the EtherCAT Coupler Unit, and an NX Unit connected to the NX bus of the NX Bus Function Module or the CPU Unit in the I/O Map of the Sysmac Studio. Refer to the *Sysmac Studio Version 1 Operation Manual* (Cat. No. W504-E1-07 or later) for details on assigning device variables.
- If the RestartNXUnit instruction is executed during execution of another RestartNXUnit instruction or execution of the NX_ChangeWriteMode instruction (page 2-866), the RestartNXUnit instruction that is executed later will be queued. Up to 192 instructions can be queued. A building error will occur if an attempt is made to queue more than 192 instructions. The time that an instruction is queued is not included in the timeout time.
- The value of *Busy* is TRUE while the instruction is queued.
- This instruction is related to NX Message Communications Errors. If too many instructions that are related to NX Message Communications Errors are executed at the same time, an NX Message Communications Error will occur. Refer to *A-5 Instructions Related to NX Message Communications Errors* for a list of the instructions that are related to NX Message Communications Errors.

- You cannot execute this instruction during execution of the following instructions: EC_DisconnectSlave, EC_ConnectSlave, EC_ChangeEnableSetting, ResetECError, RestartNXUnit, and NX_ChangeWriteMode. An error will occur if you attempt to execute it.
- Error* is TRUE if an error occurred. The meanings of the values of *ErrorID* and *ErrorIDEx* are given in the following table.

Value of <i>ErrorID</i>	Value of <i>ErrorIDEx</i>	Meaning	
16#0419	16#00000000	The data type of <i>UnitProxy</i> is not correct.	
	16#00000401	The specified Unit does not support the instruction.	
	16#00001001 16#00001002 16#00170000 16#00200000 16#00210000	An input parameter, output parameter, or in-out parameter is incorrect. Confirm that the intended parameter is used for the input parameter, output parameter, or in-out parameter.	
	16#00001010	The data size of the specified NX object does not agree with the data size specified in <i>WriteDat</i> .	
	16#00001101	The Unit is not correct. Check the Unit.	
	16#0000110B	The size of the read data is too large. Make sure that the read data specification is correct.	
	16#00001110	There is no object that corresponds to the value of <i>Obj.Index</i> .	
	16#00001111	There is no object that corresponds to the value of <i>Obj.Subindex</i> .	
	16#00002101	The specified NX object cannot be written.	
	16#00002110	The value of <i>WriteDat</i> exceeds the range of the values of the NX object to write.	
	16#00002210	The specified Unit is not in a mode that allows writing data.	
	16#00002213	Instruction execution was not possible because the specified Unit was performing an I/O check. Execute the instruction after the I/O check is completed.	
	16#2C00	16#00002230	The status of the specified Unit does not agree with the value of the read source or write destination NX object. Take the following actions if the value of <i>Obj.Index</i> is between 0x6000 and 0x6FFF or between 0x7000 and 0x7FFF. <ul style="list-style-type: none"> Delete the read source or write designation NX object from the I/O allocation settings. Reset the error for the specified Unit. Place the specified Unit in a mode that does not allow writing data.
		16#00002231	Instruction execution was not possible because the specified Unit was performing initialization. Wait for the Unit to start normal operation and then execute the instruction.
		16#0000250F	Hardware access failed. Execute the instruction again.
		16#00002601 16#00002602 16#00100000	The specified Unit does not support this instruction. Check the version of the Unit.
		16#00002603	Execution of the instruction failed. Execute the instruction again. Make sure that at least one channel is enabled in the selections of the channels to use.
16#00002621		The NX Unit is not in a status in which it can acknowledge the instruction. Wait for a while and then execute the instruction again.	
16#00010000		The specified Unit does not exist. Make sure that the Unit configuration is correct.	
16#00110000	The specified port number does not exist. Make sure that the Unit configuration is correct.		

Value of <i>ErrorID</i>	Value of <i>ErrorIDEx</i>	Meaning
16#2C00	16#00120000 16#00130000 16#00150000 16#00160000	The value of <i>UnitProxy</i> is not correct. Set the variable that indicates the specified EtherCAT Coupler Unit again.
	16#00140000	The specified node address is not correct. Make sure that the Unit configuration is correct.
	16#00300000 16#80010000	The specified Unit is busy. Execute the instruction again.
	16#00310000	The specified Unit is not supported for connection. Check the version of the Unit.
	16#80000000 16#80050000 16#81010000 16#81020000 16#82020000 16#82030000 16#82060000 to 16#8FFF0000 16#90010000 to 16#FFFE0000	An error occurred in the communications network. Execute the instruction again.
	16#80020000 16#80030000 16#81030000 16#82000000	An error occurred in the communications network. Reduce the amount of communications traffic.
	16#80040000 16#81000000 16#82010000 16#82040000 16#82050000 16#90000000	An error occurred in the communications network. Check the Unit and cable connections. Make sure that the power supply to the Unit is ON.
16#2C01	16#00000000	An attempt was made to queue more than 192 RestartNXUnit and NX_ChangeWriteMode instructions.
16#2C02	16#00000000	A timeout occurred during communications.
16#2C05	---	An error occurred in the EtherCAT network. Check the value of <i>UnitProxy</i> and the EtherCAT network configuration.
16#2C06	16#00000000	The specified Unit is already being restarted from the Sysmac Studio. Therefore, this instruction does not need to be executed.
16#2C07	16#00000000	A slave that cannot be specified for the instruction was connected at the slave node address of the specified Unit. Check the value of <i>UnitProxy</i> and the EtherCAT network configuration.



Version Information

A CPU Unit with unit version 1.05 or later and Sysmac Studio version 1.06 or higher are required to use this instruction. However, some versions/unit versions of the following products do not support restarting specified NX Units independently.

- CPU Units
- Sysmac Studio
- EtherCAT Coupler Units
- NX Units

If the unit version of a product does not support restarting specified NX Units independently, you can specify only the EtherCAT Coupler Unit as the Unit to restart.

Refer to the *NX-series EtherCAT Coupler Unit User's Manual* (Cat. No. W519-E1-03 or later) for the unit versions of products that support restarting specified NX Units independently.

Sample Programming

Refer to the sample programming for the NX_WriteObj instruction (page 2-972).

NX_ChangeWriteMode

The NX_ChangeWriteMode instruction changes an EtherCAT Coupler Unit or NX Unit to a mode that allows writing data.

Instruction	Name	FB/FUN	Graphic expression	ST expression
NX_ChangeWriteMode	Change to NX Unit Write Mode	FB		NX_ChangeWriteMode_instance (Execute, UnitProxy, Done, Busy, Error, ErrorID, ErrorIDEx);

Variables

Name	Meaning	I/O	Description	Valid range	Unit	Default
UnitProxy	Specified Unit	Input	Unit for which to change the mode	---	---	*

* If you omit the input parameter, the default value is not applied. A building error will occur.

	Boolean	Bit strings					Integers							Real numbers	Times, durations, dates, and text strings					
	BOOL	BYTE	WORD	DWORD	LWORD	USINT	UINT	UDINT	ULINT	SINT	INT	DINT	LINT	REAL	LREAL	TIME	DATE	TOD	DT	STRING
UnitProxy																				Refer to <i>Function</i> for details on the structure <code>_sNXUNIT_ID</code> .

Function

The NX_ChangeWriteMode instruction changes the mode for an EtherCAT Coupler Unit, an NX Unit on the EtherCAT Coupler Unit, or an NX Unit connected to the NX bus of the CPU Unit to a mode that allows writing data. The Unit for which to change the mode is specified with *UnitProxy*. Data can be written when the value of *Done* changes to TRUE.

The data type of *UnitProxy* is structure `_sNXUNIT_ID`. The meanings of the members are as follows:

Name	Meaning	Content	Data type
UnitProxy	Specified Unit	Unit for which to change the write mode	<code>_sNXUNIT_ID</code>
NodeAdr	Node address	Node address of the Communications Coupler Unit	UINT
IPAdr	IP address	IP address of the Communications Coupler Unit	BYTE[5]
UnitNo	Unit number	Unit number of specified Unit	UDINT
Path	Path	Path information to the specified Unit	BYTE[64]
PathLength	Valid path length	Valid path length	USINT

Pass the device variable that is assigned to the specified Unit to *UnitProxy*.

Related Instructions and Execution Procedure

You can use this instruction to write data with the following attributes to an EtherCAT Coupler Unit, an NX Unit on the EtherCAT Coupler Unit, or an NX Unit connected to the NX bus of the CPU Unit.

- Power OFF Retain attribute
- The values are updated when the Unit is restarted.

Use the following procedure to execute the related instructions.

- 1** Use the NX_ChangeWriteMode instruction to change the Units to a mode that allows writing data.
- 2** Use the NX_WriteObj instruction (page 2-972) to write data to the Unit.
- 3** Use the NX_SaveParam instruction (page 2-871) to save the data that you wrote.
- 4** Use the RestartNXUnit instruction (page 2-860) to restart the Unit.

Notation Example

The following notation example changes the 'NX1' NX Unit to a mode that allows writing data. A variable that is named 'NX1' with a data type of _sNXUNIT_ID is assigned to the NX Unit to change.

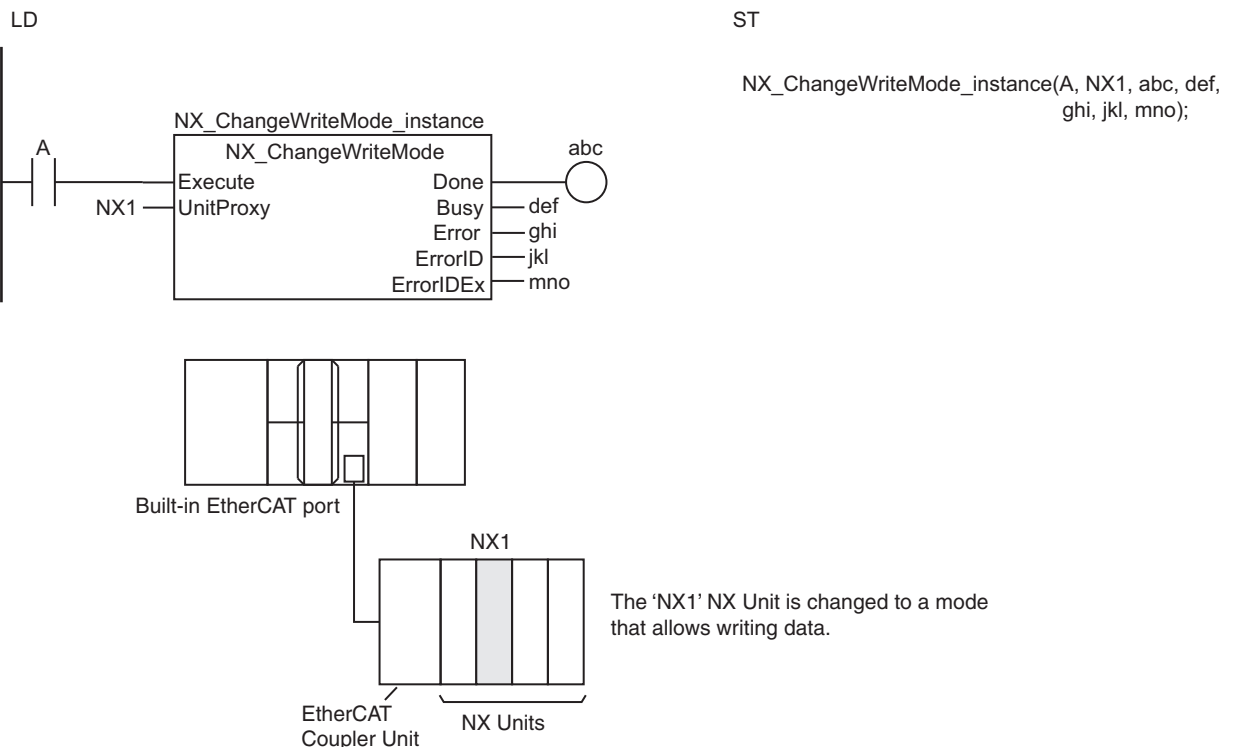

Related System-defined Variables

Name	Meaning	Data type	Description
_EC_MBXSlaveTbl[i] “i” is the node address.	Message Communications Enabled Slave Table	BOOL	This variable indicates whether communications are possible for each slave. TRUE: Communications are possible. FALSE: Communications are not possible.
_NXB_UnitMsgActiveTbl [i]	NX Unit Message Enabled Status	BOOL	This table indicates the slaves that can perform message communications. Use this variable to confirm that communications with the relevant slave are possible.

Precautions for Correct Use

- Execution of this instruction is continued until processing is completed even if the value of *Execute* changes to FALSE or the execution time exceeds the task period. The value of *Done* changes to TRUE when processing is completed. Use this to confirm normal completion of processing.
- Refer to *Using this Section* (page 2-3) for a timing chart for *Execute*, *Done*, *Busy*, and *Error*.
- If you specify a Unit that is assigned to a motion control axis (data type *_sAXIS_REF*) for *UnitProxy*, a Controller error will occur in the Motion Control Function Module. If that occurs, use the *ResetMCErr* instruction (page 2-828) to reset the Controller error.
- For *UnitProxy*, specify the device variable that is assigned to an EtherCAT Coupler Unit, an NX Unit on the EtherCAT Coupler Unit, or an NX Unit connected to the NX bus of the CPU Unit in the I/O Map of the Sysmac Studio. Refer to the *Sysmac Studio Version 1 Operation Manual* (Cat. No. W504-E1-07 or later) for details on assigning device variables.
- If the *NX_ChangeWriteMode* instruction is executed during execution of another *NX_ChangeWriteMode* instruction or execution of the *RestartNXUnit* instruction (page 2-860), the *RestartNXUnit* instruction that is executed later will be queued. Up to 192 instructions can be queued. A building error will occur if an attempt is made to queue more than 192 instructions. The time that an instruction is queued is not included in the timeout time.
- The value of *Busy* is TRUE while the instruction is queued.
- This instruction is related to NX Message Communications Errors. If too many instructions that are related to NX Message Communications Errors are executed at the same time, an NX Message Communications Error will occur. Refer to *A-5 Instructions Related to NX Message Communications Errors* for a list of the instructions that are related to NX Message Communications Errors.
- You cannot execute this instruction during execution of the following instructions: *EC_DisconnectSlave*, *EC_ConnectSlave*, *EC_ChangeEnableSetting*, *ResetECError*, *RestartNXUnit*, and *NX_ChangeWriteMode*. An error will occur if you attempt to execute it.

- *Error* is TRUE if an error occurred. The meanings of the values of *ErrorID* and *ErrorIDEx* are given in the following table.

Value of <i>ErrorID</i>	Value of <i>ErrorIDEx</i>	Meaning
16#0419	16#00000000	The data type of <i>UnitProxy</i> is not correct.
16#2C00	16#00000401	The specified Unit does not support the instruction.
	16#00001001 16#00001002 16#00170000 16#00200000 16#00210000	An input parameter, output parameter, or in-out parameter is incorrect. Confirm that the intended parameter is used for the input parameter, output parameter, or in-out parameter.
	16#00001010	The data size of the specified NX object does not agree with the data size specified in <i>WriteDat</i> .
	16#00001101	The correct Unit was not specified. Check the Unit.
	16#0000110B	The size of the read data is too large. Make sure that the read data specification is correct.
	16#00001110	There is no object that corresponds to the value of <i>Obj.Index</i> .
	16#00001111	There is no object that corresponds to the value of <i>Obj.Subindex</i> .
	16#00002101	The specified NX object cannot be written.
	16#00002110	The value of <i>WriteDat</i> exceeds the range of the values of the NX object to write.
	16#00002210	The specified Unit is not in a mode that allows writing data.
	16#00002213	Instruction execution was not possible because the specified Unit was performing an I/O check. Execute the instruction after the I/O check is completed.
	16#00002230	The status of the specified Unit does not agree with the value of the read source or write destination NX object. Take the following actions if the value of <i>Obj.Index</i> is between 0x6000 and 0x6FFF or between 0x7000 and 0x7FFF. <ul style="list-style-type: none"> • Delete the read source or write designation NX object from the I/O allocation settings. • Reset the error for the specified Unit. • Place the specified Unit in a mode that does not allow writing data.
	16#00002231	Instruction execution was not possible because the specified Unit was performing initialization. Wait for the Unit to start normal operation and then execute the instruction.
	16#0000250F	Hardware access failed. Execute the instruction again.
	16#00002601 16#00002602 16#00100000	The specified Unit does not support this instruction. Check the version of the Unit.
	16#00002603	Execution of the instruction failed. Execute the instruction again. Make sure that at least one channel is enabled in the selections of the channels to use.
	16#00002621	The NX Unit is not in a status in which it can acknowledge the instruction. Wait for a while and then execute the instruction again.
	16#00010000	The specified Unit does not exist. Make sure that the Unit configuration is correct.
	16#00110000	The specified port number does not exist. Make sure that the Unit configuration is correct.
	16#00120000 16#00130000 16#00150000 16#00160000	The value of <i>UnitProxy</i> is not correct. Set the variable that indicates the specified EtherCAT Coupler Unit again.

Value of <i>ErrorID</i>	Value of <i>ErrorIDEx</i>	Meaning	
16#2C00	16#0014 0000	The specified node address is not correct. Make sure that the Unit configuration is correct.	
	16#0030 0000 16#8001 0000	The specified Unit is busy. Execute the instruction again.	
	16#0031 0000	The specified Unit is not supported for connection. Check the version of the Unit.	
	16#8000 0000 16#8005 0000 16#8101 0000 16#8102 0000 16#8202 0000 16#8203 0000 16#8206 0000 to 16#8FFF 0000 16#9001 0000 to 16#FFFE 0000	An error occurred in the communications network. Execute the instruction again.	
	16#8002 0000 16#8003 0000 16#8103 0000 16#8200 0000	An error occurred in the communications network. Reduce the amount of communications traffic.	
	16#8004 0000 16#8100 0000 16#8201 0000 16#8204 0000 16#8205 0000 16#9000 0000	An error occurred in the communications network. Check the Unit and cable connections. Make sure that the power supply to the Unit is ON.	
	16#2C01	16#0000 0000	An attempt was made to queue more than 192 NX_ChangeWrite-Mode and RestartNXUnit instructions.
	16#2C02	16#0000 0000	A timeout occurred during communications.
	16#2C05	---	An error occurred in the EtherCAT network. Check the value of <i>UnitProxy</i> and the EtherCAT network configuration.
	16#2C07	16#0000 0000	A slave that cannot be specified for the instruction was connected at the slave node address of the specified Unit. Check the value of <i>UnitProxy</i> and the EtherCAT network configuration.



Version Information

A CPU Unit with unit version 1.05 or later and Sysmac Studio version 1.06 or higher are required to use this instruction.

Sample Programming

Refer to the sample programming for the NX_WriteObj instruction (page 2-972).

NX_SaveParam

The NX_SaveParam instruction saves the data that was written to the specified EtherCAT Coupler Unit or NX Unit.

Instruction	Name	FB/FUN	Graphic expression	ST expression
NX_SaveParam	Save NX Unit Parameters	FB		NX_SaveParam_instance(Execute, UnitProxy, TimeOut, Done, Busy, Error, ErrorID, ErrorIDEx);

Variables

Name	Meaning	I/O	Description	Valid range	Unit	Default
UnitProxy	Specified Unit	Input	Unit for which to save data	---	---	*
TimeOut	Timeout time		Timeout time If 0 is set, the timeout time is 2.0 s.	0 to 60,000	ms	2000 (2.0s)

* If you omit the input parameter, the default value is not applied. A building error will occur.

	Boolean	Bit strings					Integers						Real numbers	Times, durations, dates, and text strings						
	BOOL	BYTE	WORD	DWORD	LWORD	USINT	UINT	UDINT	ULINT	SINT	INT	DINT	LINT	REAL	LREAL	TIME	DATE	TOD	DT	STRING
UnitProxy																				
TimeOut							OK													

Function

The NX_SaveParam instruction saves the data that was written to an EtherCAT Coupler Unit, an NX Unit on the EtherCAT Coupler Unit, or an NX Unit connected to the NX bus of the CPU Unit. The Unit for which to save the data is specified with *UnitProxy*.

After the completion of saving the data, the value of *Done* changes to TRUE. Use the NX_WriteObj instruction (page 2-972) to write the data. Even if power is interrupted after this instruction is executed, the values of the data with a power OFF retain attribute are retained.

TimeOut specifies the timeout time. If a response does not return within the timeout time, it is assumed that communications failed. In that case, the Unit data is not saved.

The data type of *UnitProxy* is structure `_sNXUNIT_ID`. The meanings of the members are as follows:

Name	Meaning	Description	Data type
UnitProxy	Specified Unit	Unit for which to save data	<code>_sNXUNIT_ID</code>
NodeAdr	Node address	Node address of the Communications Coupler Unit	UINT
IPAdr	IP address	IP address of the Communications Coupler Unit	BYTE[5]
UnitNo	Unit number	Unit number of specified Unit	UDINT
Path	Path	Path information to the specified Unit	BYTE[64]
PathLength	Valid path length	Valid path length	USINT

Pass the device variable that is assigned to the specified Unit to *UnitProxy*.

Related Instructions and Execution Procedure

Depending on the attributes of the data that you write to an EtherCAT Coupler Unit, an NX Unit on the EtherCAT Coupler Unit, or an NX Unit connected to the NX bus of the CPU Unit, you must execute this instruction along with other instructions. The procedures for each case are given below.

● Execution Procedure 1

Use the following procedure to write data with the following attributes.

- Power OFF Retain attribute
- The values are updated when the Unit is restarted.

- 1** Use the `NX_ChangeWriteMode` instruction (page 2-866) to change the Unit to a mode that allows writing data.
- 2** Use the `NX_WriteObj` instruction (page 2-972) to write data to the Unit.
- 3** Use the `NX_SaveParam` instruction to save the data that you wrote.
- 4** Use the `RestartNXUnit` instruction (page 2-860) to restart the Unit.

● Execution Procedure 2

Use the following procedure to write data with the following attributes.

- Power OFF Retain attribute
- The values are updated as soon as they are written.

- 1** Use the `NX_WriteObj` instruction (page 2-972) to write data to the Unit.
- 2** Use the `NX_SaveParam` instruction to save the data that you wrote.

Notation Example

The following notation example saves the data that was written to the 'NX1' NX Unit. A variable that is named 'NX1' with a data type of `_sNXUNIT_ID` is assigned to the NX Unit.

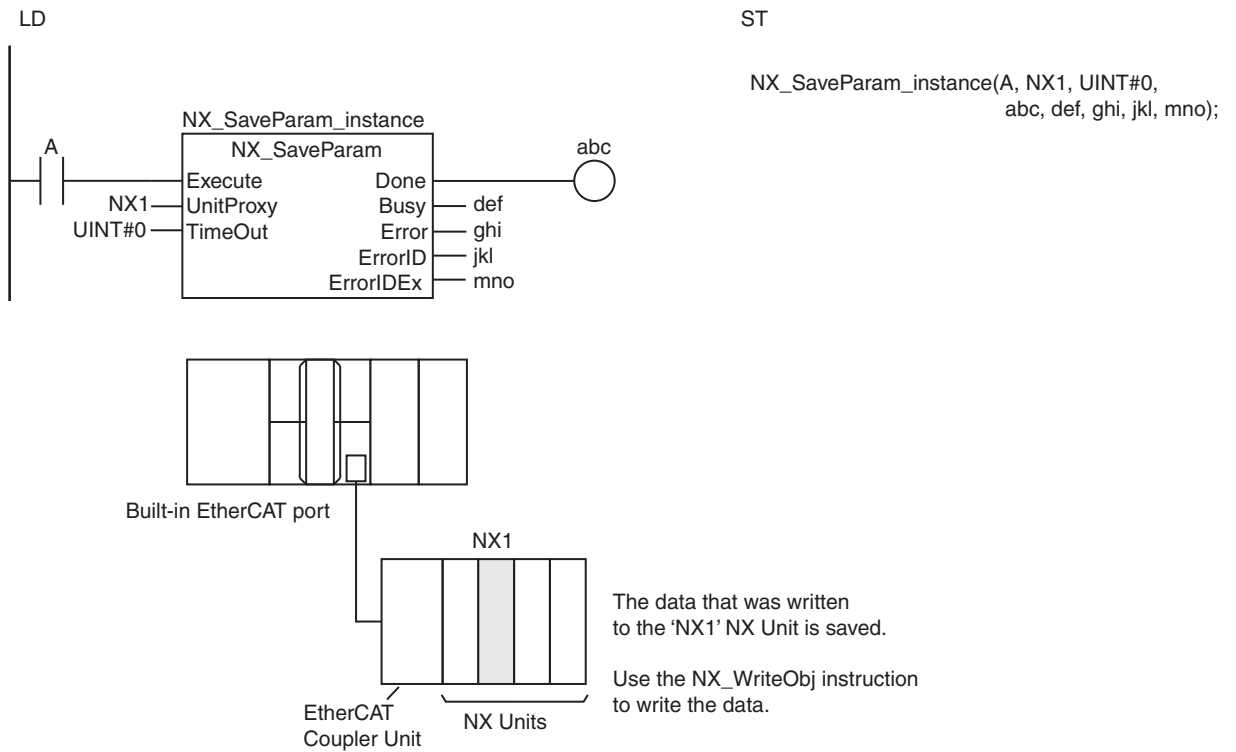

Related System-defined Variables

Name	Meaning	Data type	Description
<code>_EC_MBXSlavTbl[i]</code> "i" is the node address.	Message Communications Enabled Slave Table	BOOL	This variable indicates whether communications are possible for each slave. TRUE: Communications are possible. FALSE: Communications are not possible.

Precautions for Correct Use

- Execution of this instruction is continued until processing is completed even if the value of *Execute* changes to FALSE or the execution time exceeds the task period. The value of *Done* changes to TRUE when processing is completed. Use this to confirm normal completion of processing.
- Refer to *Using this Section* (page 2-3) for a timing chart for *Execute*, *Done*, *Busy*, and *Error*.
- This instruction will not end in an error even if the Unit specified by *UnitProxy* is already saving data. The value of *Busy* remains at TRUE and the value of *Done* changes to TRUE when saving the data is completed. Requests to save data are not queued.
- An error will not occur even if this instruction is executed without writing data to the Unit.
- Some of the Units have restrictions in the number of times that you can write data. Refer to the manuals for the specific Units for details.
- For *UnitProxy*, specify the device variable that is assigned to an EtherCAT Coupler Unit, an NX Unit on the EtherCAT Coupler Unit, or an NX Unit connected to the NX bus of the CPU Unit in the I/O Map of the Sysmac Studio. Refer to the *Sysmac Studio Version 1 Operation Manual* (Cat. No. W504-E1-07 or later) for details on assigning device variables.
- To write and save data with a Power OFF Retain attribute, execute the NX_SaveParam instruction after you execute the NX_WriteObj instruction (page 2-970). If you restart the Unit before you execute the NX_SaveParam instruction, the previous NX object data is restored.
- This instruction is related to NX Message Communications Errors. If too many instructions that are related to NX Message Communications Errors are executed at the same time, an NX Message Communications Error will occur. Refer to *A-5 Instructions Related to NX Message Communications Errors* for a list of the instructions that are related to NX Message Communications Errors.

- *Error* is TRUE if an error occurred. The meanings of the values of *ErrorID* and *ErrorIDEx* are given in the following table.

Value of <i>ErrorID</i>	Value of <i>ErrorIDEx</i>	Meaning
16#0400	16#0000 0000	<ul style="list-style-type: none"> • The value of <i>UnitProxy</i> is outside of the valid range. • The value of <i>TimeOut</i> is outside of the valid range.
16#0419	16#0000 0000	The data type of <i>UnitProxy</i> is not correct.
16#2C00	16#0000 0401	The specified Unit does not support the instruction.
	16#0000 1001 16#0000 1002 16#0017 0000 16#0020 0000 16#0021 0000	An input parameter, output parameter, or in-out parameter is incorrect. Confirm that the intended parameter is used for the input parameter, output parameter, or in-out parameter.
	16#0000 1010	The data size of the specified NX object does not agree with the data size specified in <i>WriteDat</i> .
	16#0000 1101	The correct Unit was not specified. Check the Unit.
	16#0000 110B	The size of the read data is too large. Make sure that the read data specification is correct.
	16#0000 1110	There is no object that corresponds to the value of <i>Obj.Index</i> .
	16#0000 1111	There is no object that corresponds to the value of <i>Obj.Subindex</i> .
	16#0000 2101	The specified NX object cannot be written.
	16#0000 2110	The value of <i>WriteDat</i> exceeds the range of the values of the NX object to write.
	16#0000 2210	The specified Unit is not in a mode that allows writing data.
	16#0000 2213	Instruction execution was not possible because the specified Unit was performing an I/O check. Execute the instruction after the I/O check is completed.
	16#0000 2230	The status of the specified Unit does not agree with the value of the read source or write destination NX object. Take the following actions if the value of <i>Obj.Index</i> is between 0x6000 and 0x6FFF or between 0x7000 and 0x7FFF. <ul style="list-style-type: none"> • Delete the read source or write designation NX object from the I/O allocation settings. • Reset the error for the specified Unit. • Place the specified Unit in a mode that does not allow writing data.
	16#0000 2231	Instruction execution was not possible because the specified Unit was performing initialization. Wait for the Unit to start normal operation and then execute the instruction.
	16#0000 250F	Hardware access failed. Execute the instruction again.
	16#0000 2601 16#0000 2602 16#0010 0000	The specified Unit does not support this instruction. Check the version of the Unit.
	16#0000 2603	Execution of the instruction failed. Execute the instruction again. Make sure that at least one channel is enabled in the selections of the channels to use.
	16#0000 2621	The NX Unit is not in a status in which it can acknowledge the instruction. Wait for a while and then execute the instruction again.
	16#0001 0000	The specified Unit does not exist. Make sure that the Unit configuration is correct.
	16#0011 0000	The specified port number does not exist. Make sure that the Unit configuration is correct.

Value of <i>ErrorID</i>	Value of <i>ErrorIDEx</i>	Meaning	
16#2C00	16#00120000 16#00130000 16#00150000 16#00160000	The value of <i>UnitProxy</i> is not correct. Set the variable that indicates the specified EtherCAT Coupler Unit again.	
	16#00140000	The specified node address is not correct. Make sure that the Unit configuration is correct.	
	16#00300000 16#80010000	The specified Unit is busy. Execute the instruction again.	
	16#00310000	The specified Unit is not supported for connection. Check the version of the Unit.	
	16#80000000 16#80050000 16#81010000 16#81020000 16#82020000 16#82030000 16#82060000 to 16#8FFF0000 16#90010000 to 16#FFFE0000	An error occurred in the communications network. Execute the instruction again.	
	16#80020000 16#80030000 16#81030000 16#82000000	An error occurred in the communications network. Reduce the amount of communications traffic.	
	16#80040000 16#81000000 16#82010000 16#82040000 16#82050000 16#90000000	An error occurred in the communications network. Check the Unit and cable connections. Make sure that the power supply to the Unit is ON.	
	16#2C01	16#00000000	The number of instructions that can be simultaneously executed was exceeded.
	16#2C02	16#00000000	A timeout occurred during communications.



Version Information

A CPU Unit with unit version 1.05 or later and Sysmac Studio version 1.06 or higher are required to use this instruction.

Sample Programming

Refer to the sample programming for the NX_WriteObj instruction (page 2-972).

NX_ReadTotalPowerOnTime

The NX_ReadTotalPowerOnTime instruction reads the total power ON time from a Communications Coupler Unit or NX Unit.

Instruction	Name	FB/FUN	Graphic expression	ST expression
NX_ReadTotalPowerOnTime	Read NX Unit Total Power ON Time	FB		NX_ReadTotalPowerOnTime_instance(Execute, UnitProxy, Done, Busy, Error, ErrorID, ErrorIDEx, TotalPowerOnTime);

Variables

Name	Meaning	I/O	Description	Valid range	Unit	Default
UnitProxy	Specified Unit	Input	Specifies the target NX Unit.	---	---	*
TotalPowerOnTime	Total power ON time	Output	Stores the total power ON time that was read.	Depends on data type.		0

* If you omit an input parameter, the default value is not applied. A building error will occur.

	Boolean	Bit strings				Integers							Real numbers	Times, durations, dates, and text strings							
	BOOL	BYTE	WORD	DWORD	LWORD	USINT	UINT	UDINT	ULINT	SINT	INT	DINT	LINT	REAL	LREAL	TIME	DATE	TOD	DT	STRING	
UnitProxy																					
TotalPowerOnTime																OK					

Function

The NX_ReadTotalPowerOnTime instruction reads the approximate total power ON time from a Communications Coupler Unit, an NX Unit on the Communications Coupler Unit, or an NX Unit connected to the NX bus of the CPU Unit.

The accuracy is 1 hour per month.

The Unit from which the total power ON time is read is specified with *UnitProxy*.

When the value of *Done* changes to TRUE, the total power ON time has been read.

The data type of *UnitProxy* is structure `_sNXUNIT_ID`. The meanings of the members are as follows:

Name	Meaning	Description	Data type
UnitProxy	Specified Unit	Specified Unit	_sNXUNIT_ID
NodeAdr	Node address	Node address of the Communications Coupler Unit	UINT
IPAdr	IP address	IP address of the Communications Coupler Unit	BYTE[5]
UnitNo	Unit number	Unit number of specified NX Unit	UDINT
Path	Path	Path information to the specified Unit	BYTE[64]
PathLength	Valid path length	Valid path length	USINT

Pass a device variable that is assigned to the specified Communications Coupler Unit, an NX Unit on the Communications Coupler Unit, or an NX Unit connected to the NX bus of the CPU Unit to *UnitProxy*.

Version Combinations

There are combinations in which you can read the total power ON time depending on the version of the Communications Coupler Unit connected to the CPU Unit, NX Unit on the Communications Coupler Unit, or NX Unit connected to the NX bus of the CPU Unit.

● EtherCAT Slave Terminal

Unit	Version of NX Unit	Version of EtherCAT Coupler Unit
Digital I/O Unit	Version 1.0 or later	Version 1.2 or later
Analog I/O Unit		
System Unit		
Position Interface Unit	Version 1.1 or later	
Temperature Input Unit		

● NX Unit on NX1P2 CPU Unit

Unit	Version of NX Unit
Digital I/O Unit	Version 1.0 or later
Analog I/O Unit	
System Unit	
Position Interface Unit	Version 1.1 or later
Temperature Input Unit	

Related System-defined Variables

Name	Meaning	Data type	Description
_EC_MBXSlavTbl[i] “i” is the node address.	Message Communications Enabled Slave Table	BOOL	This variable indicates when communications are possible for each slave. TRUE: Communications are possible. FALSE: Communications are not possible.
_NXB_UnitMsgActiveTbl[i]	NX Unit Message Enabled Status	BOOL	This table indicates the slaves that can perform message communications. Use this variable to confirm that communications with the relevant slave are possible.

Additional Information

If this instruction is executed by the Simulator, *Busy* changes to TRUE for only one task period after *Execute* changes from FALSE to TRUE.

Busy changes to FALSE and *Done* changes to TRUE the next task period.

The value that is read in *TotalPowerOnTime* will be 0.

Precautions for Correct Use

- Execution of this instruction is continued until processing is completed even if the value of *Execute* changes to FALSE or the execution time exceeds the task period. The value of *Done* changes to TRUE when processing is completed. Use this to confirm normal end of processing.
- Refer to *Using this Section* (page 2-3) for a timing chart for *Execute*, *Done*, *Busy*, and *Error*.
- For *UnitProxy*, specify the device variable that is assigned to an EtherCAT Coupler Unit, an NX Unit on the EtherCAT Coupler Unit, or an NX Unit connected to the NX bus of the CPU Unit in the I/O Map of the Sysmac Studio. Refer to the *Sysmac Studio Version 1 Operation Manual* (Cat. No. W504-E1-07 or later) for details on assigning device variables.
An error will occur if you specify an NX-series CPU Unit for *UnitProxy*.
- There are restrictions in the number of Units that depend on the Communications Coupler Unit. Refer to the manual for your Communications Coupler Unit for details.
- *Error* is TRUE if an error occurred. The meanings of the values of *ErrorID* and *ErrorIDEx* are given in the following table.

Value of ErrorID	Value of ErrorIDEx	Meaning
16#0400	16#00000000	The value of <i>UnitProxy</i> is outside of the valid range.
16#0419	16#00000000	The data type of <i>UnitProxy</i> is not correct.
16#2C00	16#00000401	The specified Unit does not support the instruction.
	16#00001001 16#00001002 16#00170000 16#00200000 16#00210000	An input parameter, output parameter, or in-out parameter is incorrect. Confirm that the intended parameter is used for the input parameter, output parameter, or in-out parameter.
	16#00001010	The data size of the specified NX object does not agree with the data size specified in <i>WriteDat</i> .
	16#00001101	The Unit is not correct. Check the Unit.
	16#0000110B	The size of the read data is too large. Make sure that the read data specification is correct.
	16#00001110	There is no object that corresponds to the value of <i>Obj.Index</i> .
	16#00001111	There is no object that corresponds to the value of <i>Obj.Subindex</i> .
	16#00002101	The specified NX object cannot be written.
	16#00002110	The value of <i>WriteDat</i> exceeds the range of the values of the NX object to write.
	16#00002210	The specified Unit is not in a mode that allows writing data.
	16#00002213	Instruction execution was not possible because the specified Unit was performing an I/O check. Execute the instruction after the I/O check is completed.

Value of ErrorID	Value of ErrorIDEx	Meaning
16#2C00	16#00002230	The status of the specified Unit does not agree with the value of the read source or write destination NX object. Take the following actions if the value of <i>Obj.Index</i> is between 0x6000 and 0x6FFF or between 0x7000 and 0x7FFF. <ul style="list-style-type: none"> • Delete the read source or write destination NX object from the I/O allocation settings. • Reset the error for the specified Unit. • Place the specified Unit in a mode that does not allow writing data.
	16#00002231	Instruction execution was not possible because the specified Unit was performing initialization. Wait for the Unit to start normal operation and then execute the instruction.
	16#0000250F	Hardware access failed. Execute the instruction again.
	16#00002601 16#00002602 16#00100000	The specified Unit does not support this instruction. Check the version of the Unit.
	16#00002603	Execution of the instruction failed. Execute the instruction again. Make sure that at least one channel is enabled in the selections of the channels to use.
	16#00002621	The NX Unit is not in a status in which it can acknowledge the instruction. Wait for a while and then execute the instruction again.
	16#00010000	The specified Unit does not exist. Make sure that the Unit configuration is correct.
	16#00110000	The specified port number does not exist. Make sure that the Unit configuration is correct.
	16#00120000 16#00130000 16#00150000 16#00160000	The value of <i>UnitProxy</i> is not correct. Set the variable that indicates the specified EtherCAT Coupler Unit again.
	16#00140000	The specified node address is not correct. Make sure that the Unit configuration is correct.
	16#00300000 16#80010000	The specified Unit is busy. Execute the instruction again.
	16#00310000	The specified Unit is not supported for connection. Check the version of the Unit.
	16#80000000 16#80050000 16#81010000 16#81020000 16#82020000 16#82030000 16#82060000 to 16#8FFF0000 16#90010000 to 16#FFFE0000	An error occurred in the communications network. Execute the instruction again.
	16#80020000 16#80030000 16#81030000 16#82000000	An error occurred in the communications network. Reduce the amount of communications traffic.

Value of ErrorID	Value of ErrorIDEx	Meaning
16#2C00	16#8004 0000 16#8100 0000 16#8201 0000 16#8204 0000 16#8205 0000 16#9000 0000	An error occurred in the communications network. Check the Unit and cable connections. Make sure that the power supply to the Unit is ON.
16#2C01	16#0000 0000	The number of instructions that can be simultaneously executed was exceeded.
16#2C02	16#0000 0000	A timeout occurred during communications.
16#2C05	---	An error occurred in the EtherCAT network. Check the value of <i>UnitProxy</i> and the EtherCAT network configuration.
16#2C07	16#0000 0000	A slave that cannot be specified for the instruction was connected at the slave node address of the specified Unit. Check the value of <i>UnitProxy</i> and the EtherCAT network configuration.
16#2C08	16#0000 0000	The total power ON time could not be read.

Sample Programming

Two modes are created in a program: maintenance mode and run mode.

With this sample, if the button to read the total power ON time is pressed while in maintenance mode, the total power ON time of Unit 3 (set in advance) is read.

If the total power ON time exceeds 5 years, a lamp is lit to indicate that the Unit replacement is necessary.

If the button for completion of Unit replacement is pressed after replacing the Unit, the Unit replacement warning lamp turns OFF.

The following system configuration is used.

Unit	Description
Unit 1	NX Unit (ID)
Unit 2	NX Unit (OD)
Unit 3	NX Unit (Unit from which to read the total power ON time)

Definitions of Variables

LD

Internal Variables	Variable	Data type	Initial value	Comment
	Maintenance_Mode	BOOL	FALSE	Maintenance mode
	Run_Mode	BOOL	FALSE	Run mode
	PushButton_Read	BOOL	FALSE	Reading the total power ON time
	PushButton_Changed	BOOL	FALSE	Completion of Unit replacement
	Lamp_Warning_UnitLifeTime	BOOL	FALSE	Unit replacement warning
	Read	BOOL	FALSE	
	instance	NX_ReadTotal-PowerOnTime		

External Variables	Variable	Data type	Comment
	NX_Unit	_sNXUNIT_ID	
	J01_Ch1_In00	BOOL	Maintenance mode button
	J01_Ch1_In01	BOOL	Button to read total power ON time
	J01_Ch1_In02	BOOL	Button for completion of Unit replacement
	J02_Ch1_Out00	BOOL	Unit replacement warning lamp

Get button status.

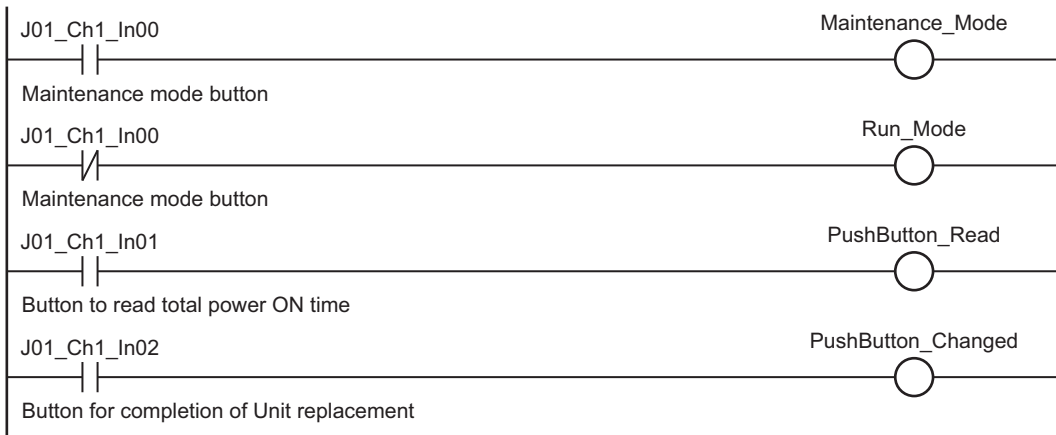

Read total power ON time.

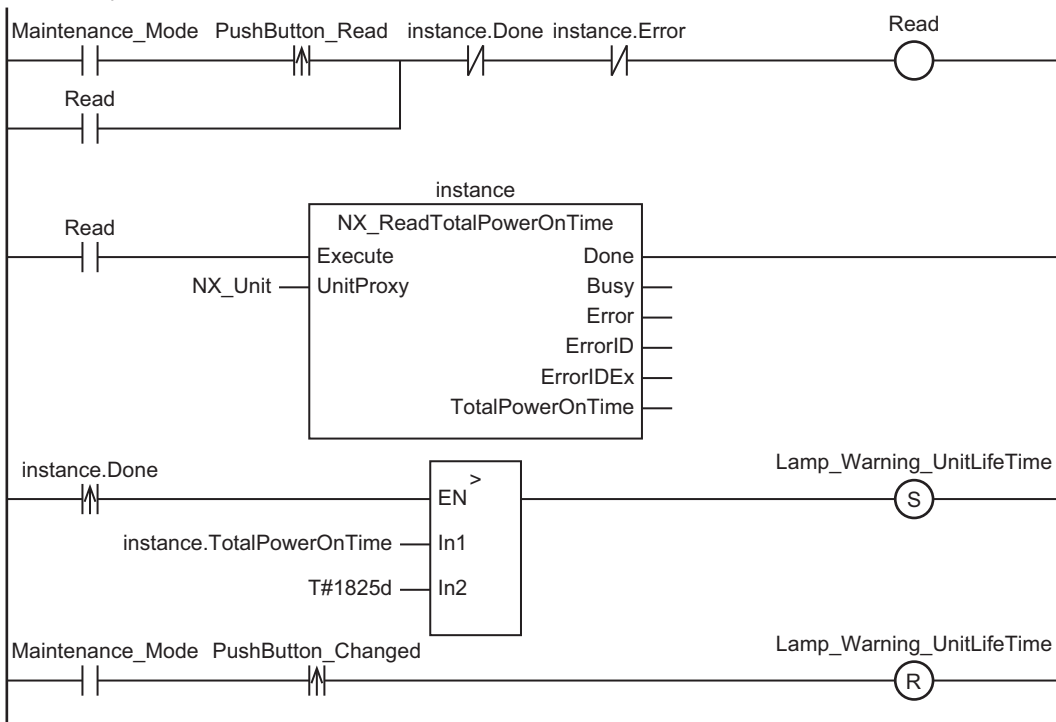

Output warning to lamp.

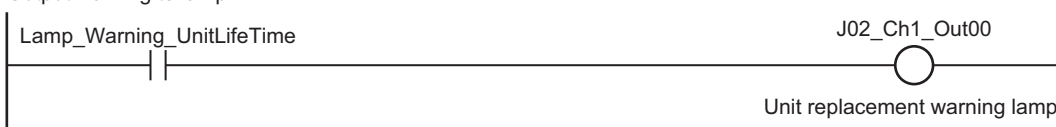

ST

Internal Variables	Variable	Data type	Initial value	Comment
	Maintenance_Mode	BOOL	FALSE	Maintenance mode
	Run_Mode	BOOL	FALSE	Run mode
	PushButton_Read	BOOL	FALSE	Reading the total power ON time
	PushButton_Changed	BOOL	FALSE	Completion of Unit replacement
	Lamp_Warning_UnitLifeTime	BOOL	FALSE	Unit replacement warning
	Read	BOOL	FALSE	
	instance	NX_ReadTotalPowerOn-Time		
	RS_instance	RS		
	RS_instance2	RS		
	R_TRIG_instance1	R_TRIG		
	R_TRIG_instance2	R_TRIG		
	R_TRIG_instance3	R_TRIG		
	PushButton_Read_R_TRIG	BOOL		
	instance_Done_R_TRIG	BOOL		
	PushButton_Change_R_TRIG	BOOL		

External Variables	Variable	Data type	Comment
	NX_Unit	_sNXUNIT_ID	
	J01_Ch1_In00	BOOL	Maintenance mode button
	J01_Ch1_In01	BOOL	Button to read total power ON time
	J01_Ch1_In02	BOOL	Button for completion of Unit replacement
	J02_Ch1_Out00	BOOL	Unit replacement warning lamp

```

// Get button status.
Maintenance_Mode := J01_Ch1_In00;
Run_Mode         := NOT(J01_Ch1_In00);
PushButton_Read  := J01_Ch1_In01;
PushButton_Changed := J01_Ch1_In02;

R_TRIG_instance1(Clk:= PushButton_Read, Q=>PushButton_Read_R_TRIG);

// Read total power ON time.
Rs_instance( Set:= (Maintenance_Mode & PushButton_Read_R_TRIG),
             Reset1:=((instance.Done) OR (instance.Error)),
             Q1=>Read);
instance(Execute:=Read, UnitProxy:=NX_Unit);

R_TRIG_instance2(Clk:= instance.Done, Q=>instance_Done_R_TRIG);
R_TRIG_instance3(Clk:= PushButton_Changed, Q=>PushButton_Changed_R_TRIG);

RS_instance2(Set:=(instance_Done_R_TRIG & (instance.TotalPowerOnTime>T#1825d)),
             Reset1:= (Maintenance_Mode & PushButton_Changed_R_TRIG),
             Q1=>Lamp_Warning_UnitLifeTime);

// Output warning to lamp.
J02_Ch1_Out00 := Lamp_Warning_UnitLifeTime;
    
```

PLC_ReadTotalPowerOnTime

The PLC_ReadTotalPowerOnTime instruction reads the total power ON time from a specified CPU Unit.

Instruction	Name	FB/ FUN	Graphic expression	ST expression
PLC_ReadTotalPowerOnTime	Read PLC Total Power ON Time	FUN		Out:=PLC_ReadTotalPowerOnTime(UnitType, ENO);



Precautions for Correct Use

You can use this instruction for the NX1P2 CPU Unit only.

Variables

Name	Meaning	I/O	Description	Valid range	Unit	Default
UnitType	Unit type	Input	Specifies the target Unit.	_CPU_UNIT	---	_CPU_UNIT
Out	Total Power ON Time	Output	Outputs the total power ON time that was read.	Depends on data type.	---	---

	Boolean	Bit strings					Integers							Real numbers	Times, durations, dates, and text strings						
	BOOL	BYTE	WORD	DWORD	LWORD	USINT	UINT	UDINT	ULINT	SINT	INT	DINT	LINT	REAL	LREAL	TIME	DATE	TOD	DT	STRING	
UnitType																					Refer to <i>Function</i> for the enumerators of the enumerated type _ePLC_UNIT_TYPE.
Out																OK					

Function

The PLC_ReadTotalPowerOnTime instruction reads the approximate total power ON time from a specified CPU Unit.

The accuracy is 1 hour per month.

Specify the Unit from which the data is read to *UnitType*.

The data type of *UnitType* is enumerated type `_ePLC_UNIT_TYPE`. The meaning of the enumerator is as follows:

Enumerator	Meaning
<code>_CPU_UNIT</code>	CPU Unit is specified.

Target Unit

● When Using the NX1P2 CPU Unit

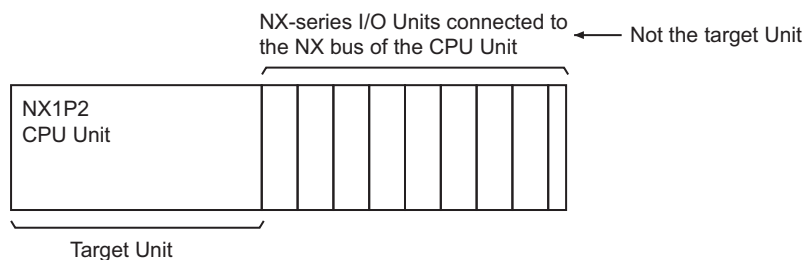

The target Unit for reading is the NX1P2 CPU Unit only.

In *UnitType*, set the `_CPU_UNIT` enumerator of the enumerated type `_ePLC_UNIT_TYPE` to specify a target Unit.

NX-series I/O Units connected to the NX bus of the CPU Unit are not the target Unit for reading.



Additional Information

To read the total power ON time for an NX-series I/O Unit, use `NX_ReadTotalPowerOnTime` on page 2-877.

Additional Information

If you execute this instruction in the Simulator, the value of *Out* is always T#0s.

Precautions for Correct Use

If the specified Unit is not the target for reading, an error will occur. *ENO* will be FALSE, and the value of *Out* will not change.

Sample Programming

This sample creates the two variables *Maintenance_Mode* and *Run_Mode* in the program.

In the two, the instruction reads the total power ON time of the NX1P2 CPU Unit when the button to read the total power ON time is pressed in *Maintenance_Mode*.

If the total power ON time exceeds 5 years, the Unit replacement warning lamp lights.

Once the Unit is replaced and the button for completion of Unit replacement is pressed, the Unit replacement warning lamp turns off.

The system configuration is as shown below.

Unit	Description
Unit 1	Unit 1, which is connected to the NX bus of the NX-series CPU Unit NX-series I/O Unit (ID)
Unit 2	Unit 2, which is connected to the NX bus of the NX-series CPU Unit NX-series I/O Unit (IO)
Unit 3	NX1P2 CPU Unit (Target for reading the total power ON time)

Definitions of Variables

ST

External Variables	Variable	Data type	Comment
	J01_Ch1_In00	BOOL	Maintenance mode button
	J01_Ch1_In01	BOOL	Button to read total power ON time
	J02_Ch1_Out00	BOOL	Unit replacement warning lamp
	Maintenance_Mode	BOOL	
	Run_Mode	BOOL	
	PushButton_Read	BOOL	
	Lamp_Warning_UnitLifeTime	BOOL	
	PowerOnTime	TIME	
	R_TRIG_instance1	R_TRIG	
	PushButton_Read_R_TRIG	BOOL	
	RS_instance	RS	

```
// Get button status.
Maintenance_Mode := J01_Ch1_In00;
Run_Mode         := NOT(J01_Ch1_In00);
PushButton_Read  := J01_Ch1_In01;

R_TRIG_instance1(clk:=PushButton_Read, Q=>PushButton_Read_R_TRIG);

// Read total operating time.
PowerOnTime := PLC_ReadTotalPowerOnTime(EN:=(Maintenance_Mode &
                                           PushButton_Read_R_TRIG),
                                           UnitType:=_CPU_UNIT);

RS_instance( Set:=(PowerOnTime > T#1825d),
             Reset1:=Maintenance_Mode,
             Q1=>Lamp_Warning_UnitLifeTime);
```

```
// Output warning to lamp.  
J02_Ch1_Out00 := Lamp_Warning_UnitLifeTime;
```

Program Control Instructions

Instruction	Name	Page
PrgStart	Enable Program	2-890
PrgStop	Disable Program	2-899
PrgStatus	Read Program Status	2-919

PrgStart

The PrgStart instruction enables the execution of the specified program.

Instruction	Name	FB/FUN	Graphic expression	ST expression
PrgStart	Enable Program	FUN		Out:=PrgStart(PrgName, isFirstRun);

Variables

Name	Meaning	I/O	Description	Valid range	Unit	Default
PrgName	Program name	Input	Name of specified program	128 bytes max. (127 single-byte alphanumeric characters plus the final NULL character)	---	*1
isFirstRun	First Program Period Flag enable		Operation of the <i>P_First_Run</i> system-defined variable in the first task period when the program is executed TRUE: Change to TRUE. FALSE: Change to FALSE.	Depends on data type.		TRUE
Out	Normal end flag	Output	Normal end flag TRUE: Normal end FALSE: Error end	Depends on data type.	---	---

*1 If you omit an input parameter, the default value is not applied. A building error will occur.

	Boolean	Bit strings				Integers							Real numbers	Times, durations, dates, and text strings						
	BOOL	BYTE	WORD	DWORD	LWORD	USINT	UINT	UDINT	ULINT	SINT	INT	DINT	LINT	REAL	LREAL	TIME	DATE	TOD	DT	STRING
PrgName																				OK
isFirstRun	OK																			
Out	OK																			

Function

The PrgStart instruction enables the execution of the program specified with *PrgName*. The specified program is executed the next time the timing for executing the program occurs. An error does not occur even if the specified program is already enabled.

The specified program can be in the same task as this instruction, or it can be in a different task.

The value of *Out* is TRUE if the instruction ends normally and FALSE if the instruction ends in an error.

Operation Example When a Program in the Current Task Is Specified

An operation example is provided below for when a program is specified that is in the same task as the task that executes the instruction.

● Enabling a Program Executed After the PrgStart Instruction

- In this example, there are three programs, P1, P2, and P3, in the same task.
- P3 is disabled from task period 1.
- The PrgStart instruction with P3 specified is executed in P2 of task period 2.
- P3 is executed after P2, so P3 is executed in task period 2.
- Thereafter, P3 remains enabled even if you do not execute the PrgStart instruction with P3 specified.

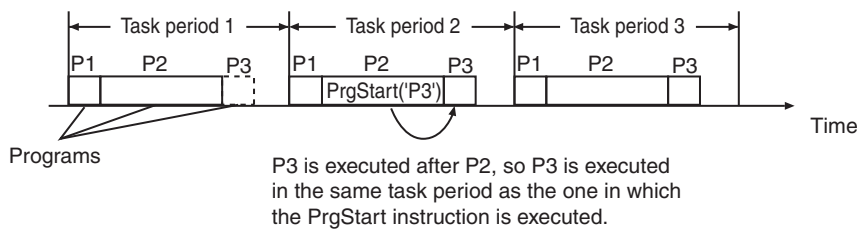

● Enabling a Program Executed Before the PrgStart Instruction

- In this example, there are three programs, P1, P2, and P3, in the same task.
- P1 is disabled from task period 1.
- The PrgStart instruction with P1 specified is executed in P2 of task period 1.
- P1 is executed before P2, so P1 is executed in task period 2.
- Thereafter, P1 remains enabled even if you do not execute the PrgStart instruction with P1 specified.

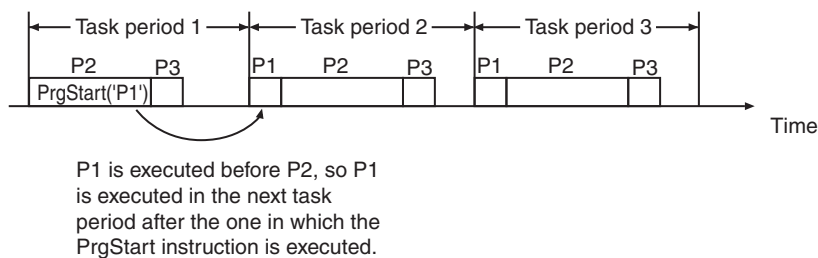

Operation Example When a Program in a Different Task Is Specified

An operation example is provided below for when a program is specified that is in a different task from the task that executes the instruction.

● Enabling a Program in a Task with a Lower Execution Priority Than the Current Task

- There are three programs in this example. P1 is in the primary periodic task, and P2 and P3 are in a periodic task.
- P3 is disabled from task period A of the periodic task.
- The PrgStart instruction with P3 specified is executed in P1 of task period 2 of the primary periodic task.
- P3 is executed in task period B of the periodic task, which is executed after the PrgStart instruction is executed.
- Thereafter, P3 remains enabled even if you do not execute the PrgStart instruction with P3 specified.

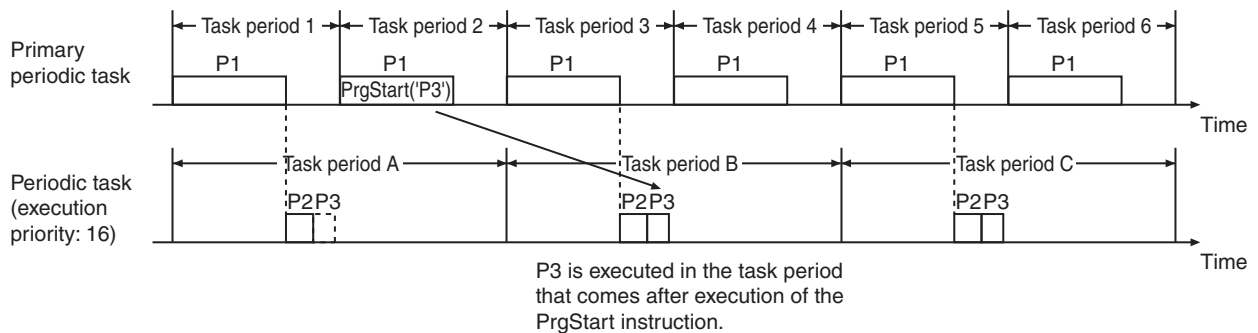

● Enabling a Program in a Task with a Higher Execution Priority Than the Current Task

- There are three programs in this example. P1 and P2 are in the primary periodic task, and P3 is in a periodic task.
- P2 is disabled from task period 1 of the primary periodic task.
- The PrgStart instruction with P2 specified is executed in P3 of task period A of the periodic task.
- P2 is executed in task period 2 of the primary periodic task, which is executed after the PrgStart instruction is executed.
- Thereafter, P2 remains enabled even if you do not execute the PrgStart instruction with P2 specified.
- The primary periodic task has a higher execution priority than a periodic task, so P3 in task period B and later is executed after processing of P2 is completed.

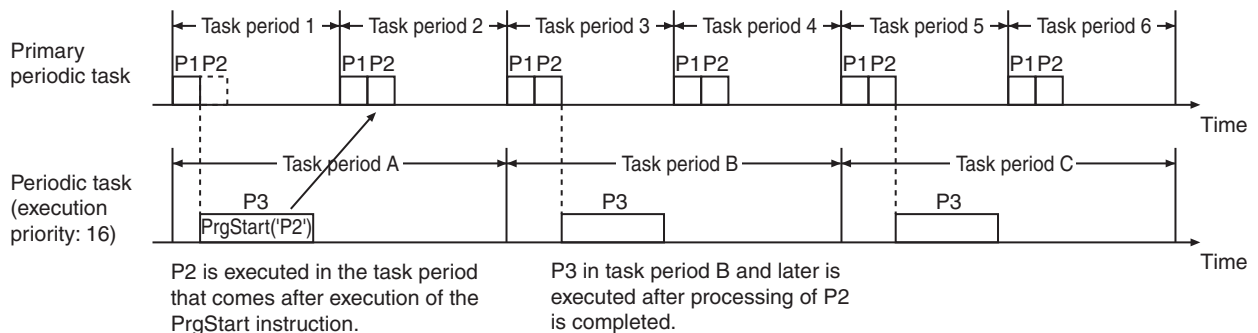

● **Enabling a Program in a Task with a Lower Execution Priority from an Event Task**

- There are three programs in this example. P1 is in an event task (execution priority: 8), and P2 and P3 are in a periodic task (execution priority: 16).
- P3 is disabled from task period 1 of the periodic task.
- The PrgStart instruction with P3 specified is executed in the event task.
- When the event task is executed, P2 and P3 in task period 2 of the periodic task are executed after processing of the event task is completed.
- As a result, P3 in task period 2 of the periodic task is executed because it comes after execution of the PrgStart instruction.
- Thereafter, P3 remains enabled even if you do not execute the PrgStart instruction with P3 specified.

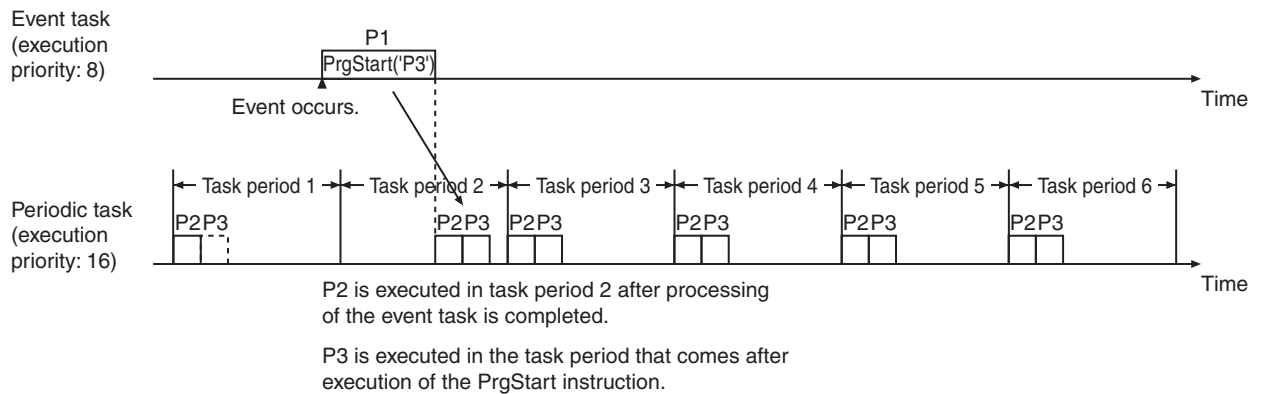

● **Enabling a Program in a Task with a Higher Execution Priority from an Event Task**

- There are three programs in this example. P1 and P2 are in the primary periodic task, and P3 is in an event task.
- P2 is disabled from task period 1 of the primary periodic task.
- The PrgStart instruction with P2 specified is executed in the event task.
- P2 is executed in task period 2 of the primary periodic task, which is executed after the PrgStart instruction is executed.
- Thereafter, P2 remains enabled even if you do not execute the PrgStart instruction with P2 specified.

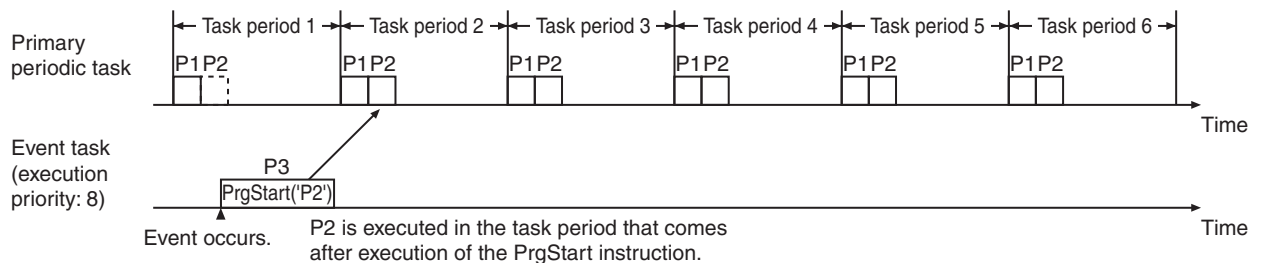

● **Enabling a Program in an Event Task with a Lower Execution Priority from a Periodic Task**

- There are three programs in this example. P1 is in a periodic task (execution priority: 16), and P2 and P3 are in an event task (execution priority: 48).
- P3 in the event task is disabled.
- The PrgStart instruction with P3 specified is executed in the periodic task.
- P3 is executed in the event task that is executed after the PrgStart instruction is executed.
- Thereafter, P3 remains enabled even if you do not execute the PrgStart instruction with P3 specified.

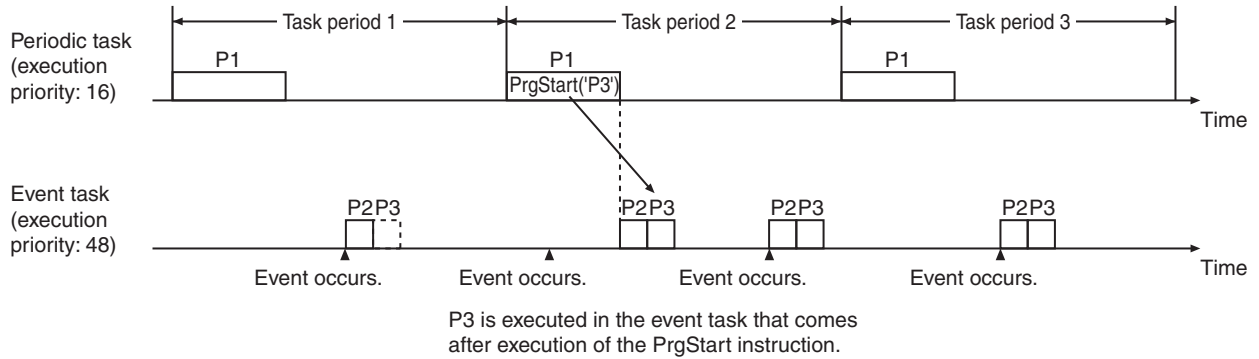

● **Enabling a Program in an Event Task with a Higher Execution Priority from a Periodic Task**

- There are three programs in this example. P1 and P2 are in an event task (execution priority: 8), and P2 is in a periodic task (execution priority: 16).
- P2 in the event task is disabled.
- The PrgStart instruction with P2 specified is executed in the periodic task.
- P2 is executed in the event task that is executed after the PrgStart instruction is executed.
- Thereafter, P2 remains enabled even if you do not execute the PrgStart instruction with P2 specified.

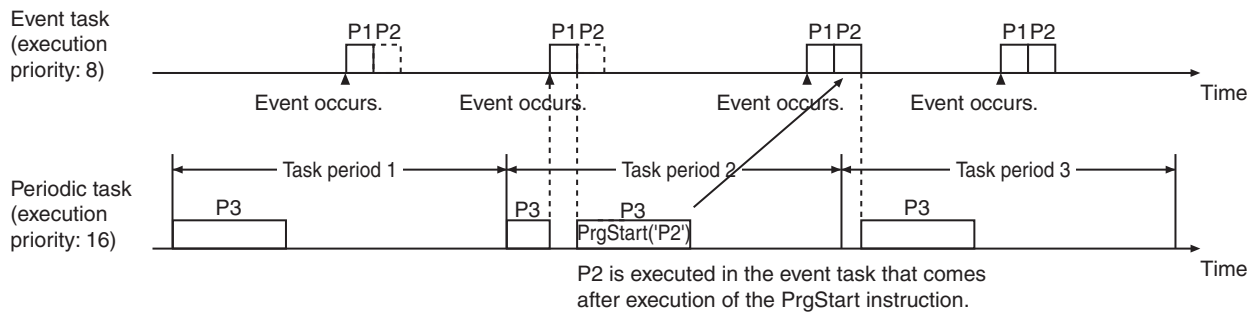

● Enabling a Program in an Event Task with a Lower Execution Priority from an Event Task

- There are three programs in this example. P1 is in an event task (execution priority: 8), and P2 and P3 are in an event task (execution priority: 48).
- P3 in the event task (execution priority: 48) is disabled.
- The PrgStart instruction with P3 specified is executed in the event task (execution priority: 8).
- P3 is executed in the event task (execution priority: 48) that is executed after the PrgStart instruction is executed.
- Thereafter, P3 remains enabled even if you do not execute the PrgStart instruction with P3 specified.

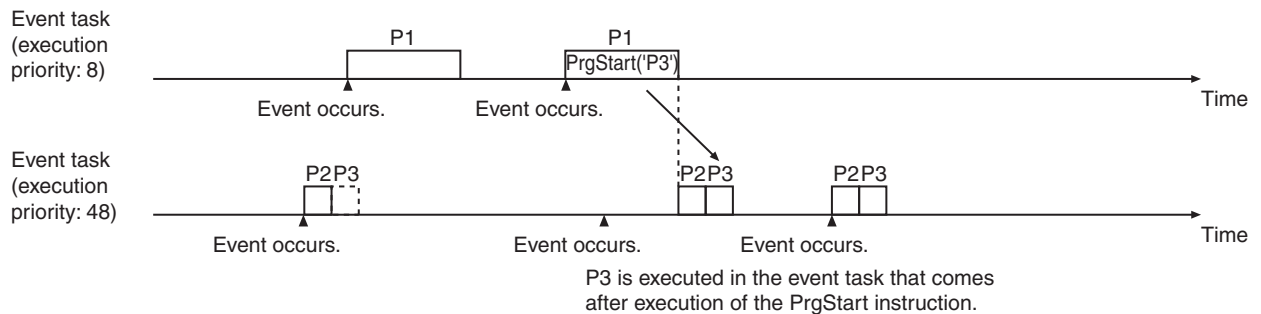

● Enabling a Program in an Event Task with a Higher Execution Priority from an Event Task

- There are three programs in this example. P1 and P2 are in an event task (execution priority: 8), and P3 is in an event task (execution priority: 48).
- P2 in the event task (execution priority: 8) is disabled.
- The PrgStart instruction with P2 specified is executed in the event task (execution priority: 48).
- P2 is executed in the event task (execution priority: 8) that is executed after the PrgStart instruction is executed.
- Thereafter, P2 remains enabled even if you do not execute the PrgStart instruction with P2 specified.

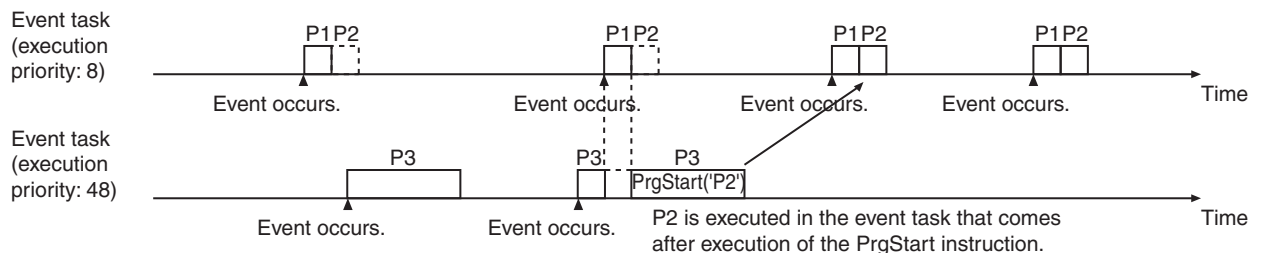

First Program Period Flag Enable (*isFirstRun*)

isFirstRun determines whether the *P_First_Run* system-defined variable is enabled as shown in the following table. If the value of *isFirstRun* is TRUE when the instruction is executed, the value of *P_First_Run* is TRUE for one task period when program execution starts. If the value of *isFirstRun* is FALSE when the instruction is executed, the value of *P_First_Run* remains FALSE even when program execution starts.

Use *isFirstRun* to perform specific processing only if specific conditions are met when program execution starts. When the specific conditions are met, change the value of *isFirstRun* to TRUE before you execute the instruction. With this program, an algorithm is used to perform specific processing when the value of *P_First_Run* is TRUE.

The relation between *isFirstRun* and *P_First_Run* is shown in the following table. The behavior of *P_First_Run* depends on whether the specified program is disabled or already enabled.

Value of <i>isFirstRun</i>	Status of the program	Value of <i>P_First_Run</i>
TRUE	Disabled.	Changes to TRUE for one task period when the program is executed. Changes to FALSE in the following task period.
	Already enabled.	Remains FALSE.
FALSE	---	Remains FALSE.

The following figures show examples of the relation between *isFirstRun* and *P_First_Run*.

● **When the Value of *isFirstRun* Is TRUE and the Program Is Disabled**

The value of *P_First_Run* changes to TRUE for one task period when execution of the program starts. Then, the value of *P_First_Run* changes to FALSE.

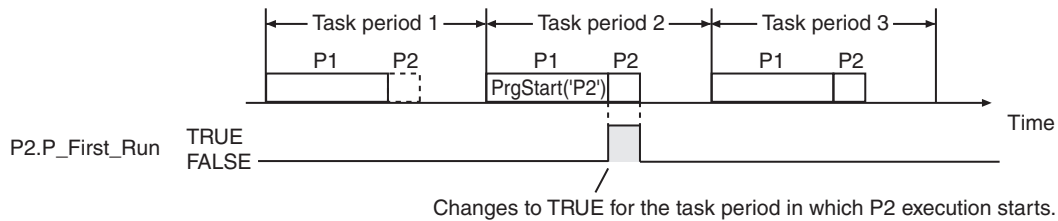

● **When the Value of *isFirstRun* Is TRUE and the Program Is Already Enabled**

The value of *P_First_Run* remains FALSE even if the PrgStart instruction is executed.

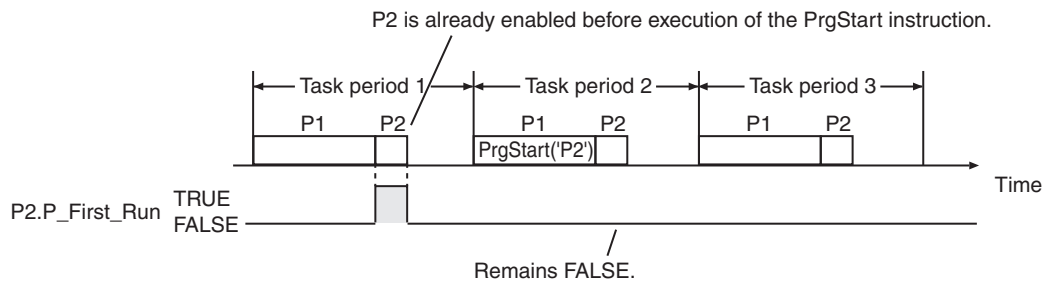

● **When the Value of *isFirstRun* Is FALSE**

The value of *P_First_Run* remains FALSE even when execution of the program starts.

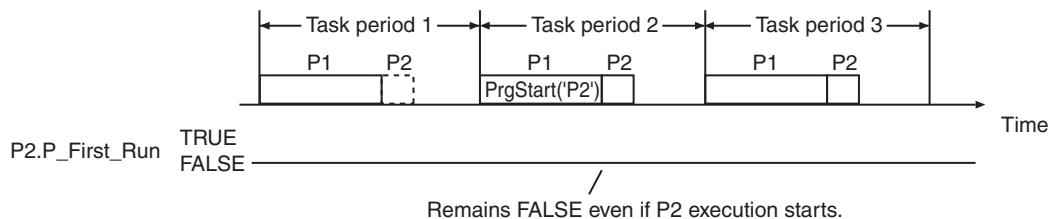

Notation Example

The following example shows the notation for specifying enabling program P1.

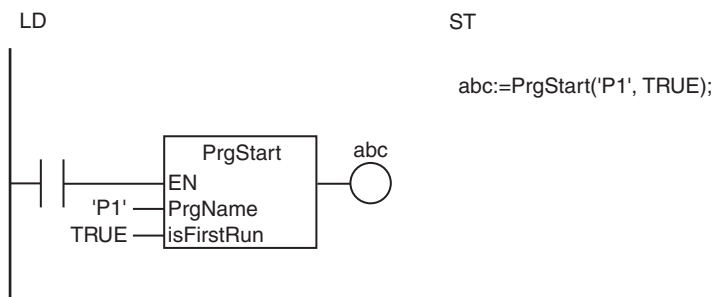

Related System-defined Variables

Name	Meaning	Data type	Description
P_First_Run	First Program Period Flag	BOOL	This flag is TRUE for one task period after execution of the program starts. Otherwise it is FALSE. However, if the value of <i>isFirstRun</i> is changed to FALSE and the PrgStart instruction is executed, <i>P_First_Run</i> remains FALSE even through execution of the program starts. Use this flag to perform specific processing when execution of a program starts.
P_First_RunMode	First RUN Period Flag	BOOL	This flag is TRUE for only one task period after the operating mode of the CPU Unit is changed from PROGRAM mode to RUN mode if execution of the program is in progress. This flag remains FALSE if execution of the program is not in progress. Use this flag to perform initialization when the CPU Unit begins operation.

Additional Information

- Use the PrgStop instruction (page 2-899) to disable a specified program from the user program.
- Use the PrgStatus instruction (page 2-919) to read the status of a specified program from the user program.

Precautions for Correct Use

- An error will not occur even if you specify a program that is already in an enabled state and execute this instruction.
- If you execute this instruction more than once for the same program, the *isFirstRun* specification in the instruction instance that was executed first is used.
- If the PrgStop instruction is executed after executing the PrgStart instruction for the same program and it is executed before the program is actually executed, the program is not executed.
- If the PrgStart instruction is executed after executing the PrgStop instruction for the same program and it is executed before the execution timing for the program, the program is not disabled.
- The operation of the programs immediately after the operating mode of the CPU Unit changes to RUN mode is controlled by the setting of the *Initial Status* for each program on the Sysmac Studio. In other words, the results of executing the PrgStart or PrgStop instruction before changing to RUN mode are not valid.
- If this instruction is executed for a program in a different task, the execution timing of the specified program will depend on the task execution priority of both tasks. In some cases, the Controller may perform unexpected operation. You can execute this instruction in the first program in the task to which the specified program is assigned to make sure that the specified program is executed in the same task period as the instruction.
- The values of the internal variables, input variables, output variables, and in-out variables from the previous time that the specified program was executed are retained. To initialize these variables before you execute the program, change the value of *isFirstRun* to TRUE before you execute the instruction and then perform initialization processing in the specified program when the value of *P_First_Run* is TRUE.
- An error will occur in the following case. *Out* will be FALSE.
 - The program specified by *PrgName* does not exist.



Version Information

A CPU Unit with unit version 1.08 or later and Sysmac Studio version 1.09 or higher are required to use this instruction.

Sample Programming

Refer to the sample programming for the PrgStop instruction (page 2-899).

PrgStop

The PrgStop instruction disables execution of the specified program.

Instruction	Name	FB/FUN	Graphic expression	ST expression
PrgStop	Disable Program	FUN		Out:=PrgStop(PrgName);

Variables

Name	Meaning	I/O	Description	Valid range	Unit	Default
PrgName	Program name	Input	Name of specified program	128 bytes max. (127 single-byte alphanumeric characters plus the final NULL character)	---	*1
Out	Normal end flag	Output	Normal end flag TRUE: Normal end FALSE: Error end	Depends on data type.	---	---

*1 If you omit an input parameter, the default value is not applied. A building error will occur.

	Boolean	Bit strings				Integers							Real numbers	Times, durations, dates, and text strings						
	BOOL	BYTE	WORD	DWORD	LWORD	USINT	UINT	UDINT	ULINT	SINT	INT	DINT	LINT	REAL	LREAL	TIME	DATE	TOD	DT	STRING
PrgName																				OK
Out	OK																			

Function

The PrgStop instruction disables execution of the program specified with *PrgName*. The specified program is disabled from the next time the timing for executing the program occurs. An error does not occur even if the specified program is already disabled.

The specified program can be in the same task as this instruction, or it can be in a different task.

You can specify the program that contains this instruction. If you specify the program that contains the instruction, the program is executed to the end in the task period in which the instruction is executed and then the program is disabled from the next task period.

The value of *Out* is TRUE if the instruction ends normally and FALSE if the instruction ends in an error.

Operation Example When a Program in the Current Task Is Specified

An operation example is provided below for when a program is specified that is in the same task as the task that executes the instruction.

● Disabling a Program Executed After the PrgStop Instruction

- In this example, there are three programs, P1, P2, and P3, in the same task.
- P3 is executed in task period 1.
- The PrgStop instruction with P3 specified is executed in P2 of task period 2.
- P3 is executed after P2, so P3 is disabled from task period 2.
- Thereafter, P3 remains disabled even if you do not execute the PrgStop instruction with P3 specified.

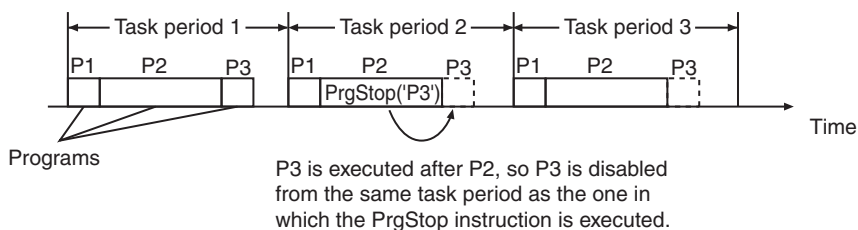

● Disabling a Program Executed Before the PrgStop Instruction

- In this example, there are three programs, P1, P2, and P3, in the same task.
- P1 is executed in task period 1.
- The PrgStop instruction with P2 specified is executed in P2 of task period 1.
- P1 is executed before P2, so P1 is disabled from task period 2.
- Thereafter, P1 remains disabled even if you do not execute the PrgStop instruction with P1 specified.

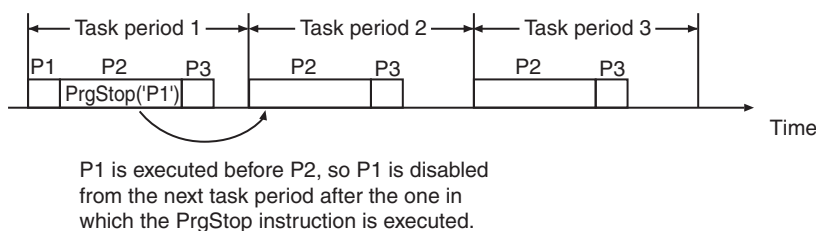

● Disabling the Program That Includes the PrgStop Instruction

- In this example, there are two programs, P1 and P2, in the same task.
- P2 is executed in task period 1.
- The PrgStop instruction with P2 specified is executed in P2 of task period 1.
- P2 is executed to the end of the program in task period 1.
- P2 is disabled from task period 2.
- Thereafter, P2 remains disabled even if you do not execute the PrgStop instruction with P2 specified.

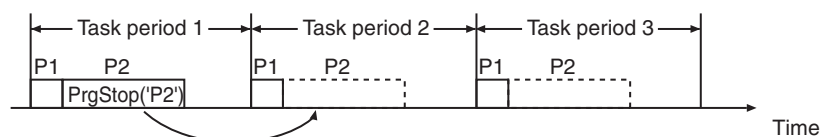

Operation Example When a Program in a Different Task Is Specified

An operation example is provided below for when a program is specified that is in a different task from the task that executes the instruction.

● Disabling a Program in a Task with a Lower Execution Priority Than the Current Task

- There are three programs in this example. P1 is in the primary periodic task, and P2 and P3 are in a periodic task.
- P3 is executed in task period A of the periodic task.
- The PrgStop instruction with P3 specified is executed in P1 of task period 2 of the primary periodic task.
- P3 is disabled from task period B of the periodic task, which is executed after the PrgStop instruction is executed.
- Thereafter, P3 remains disabled even if you do not execute the PrgStop instruction with P3 specified.

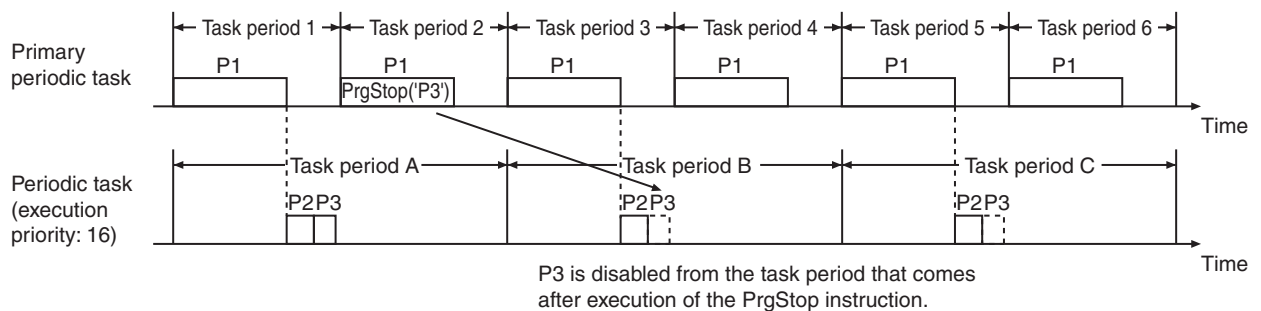

● Disabling a Program in a Task with a Higher Execution Priority Than the Current Task

- There are three programs in this example. P1 and P2 are in the primary periodic task, and P3 is in a periodic task.
- P2 is executed in task period 1 of the primary periodic task.
- The PrgStop instruction with P2 specified is executed in P3 of task period A of the periodic task.
- P2 is disabled from task period 2 of the primary periodic task, which is executed after the PrgStop instruction is executed.
- Thereafter, P2 remains disabled even if you do not execute the PrgStop instruction with P2 specified.

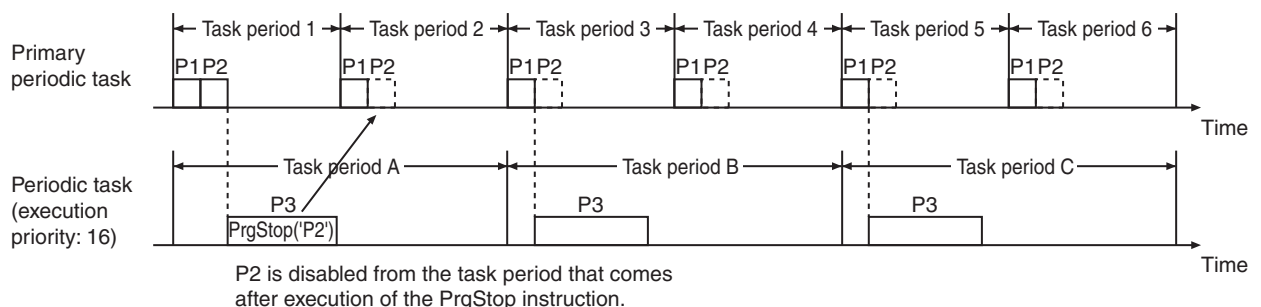

● **Disabling a Program in a Task with a Lower Execution Priority from an Event Task**

- There are three programs in this example. P1 is in an event task (execution priority: 8), and P2 and P3 are in a periodic task (execution priority: 16).
- P3 is executed in task period 1 of the periodic task.
- The PrgStop instruction with P3 specified is executed in the event task.
- When the event task is executed, P2 and P3 in task period 2 of the periodic task are executed after processing of the event task is completed.
- As a result, P3 in task period 2 of the periodic task is disabled because it comes after execution of the PrgStop instruction.
- Thereafter, P3 remains disabled even if you do not execute the PrgStop instruction with P3 specified.

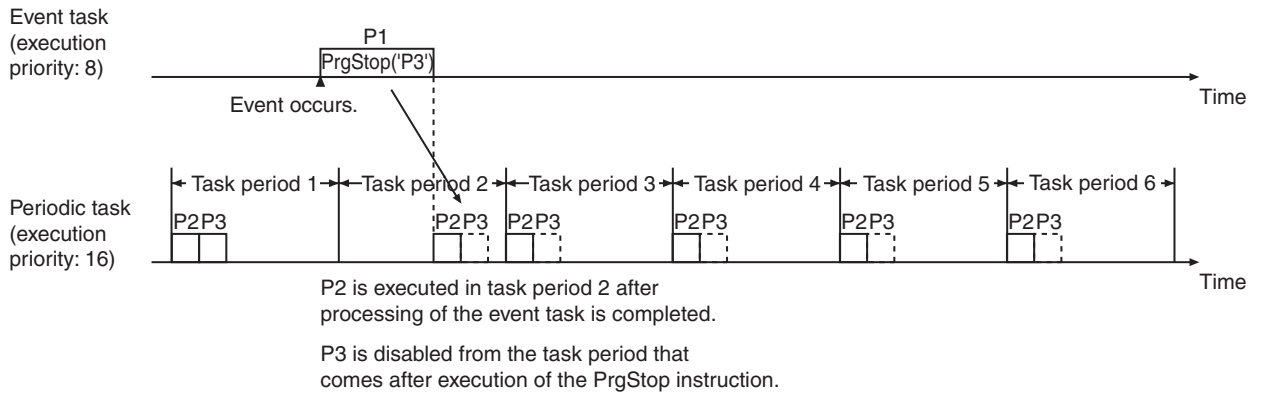

● **Disabling a Program in a Task with a Higher Execution Priority from an Event Task**

- There are three programs in this example. P1 and P2 are in the primary periodic task, and P3 is in an event task.
- P2 is executed in task period 1 of the primary periodic task.
- The PrgStop instruction with P2 specified is executed in the event task.
- P2 is disabled from task period 2 of the primary periodic task, which is executed after the PrgStop instruction is executed.
- Thereafter, P2 remains disabled even if you do not execute the PrgStop instruction with P2 specified.

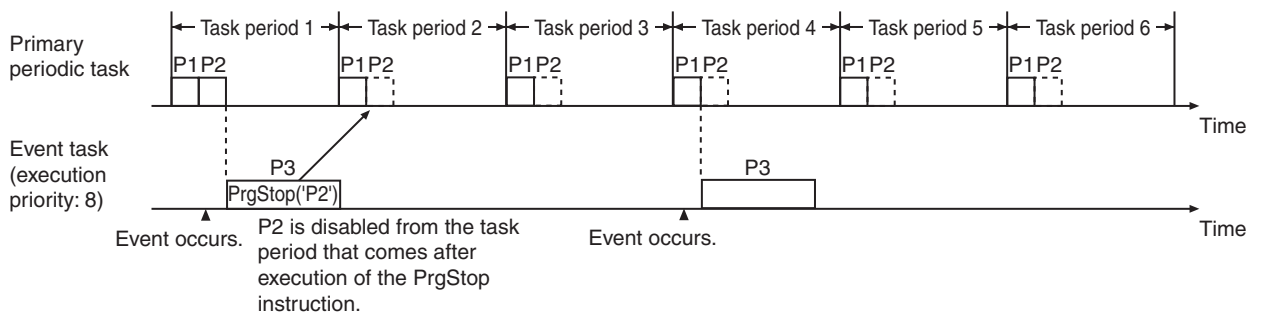

● **Disabling a Program in an Event Task with a Lower Execution Priority from a Periodic Task**

- There are three programs in this example. P1 is in a periodic task (execution priority: 16), and P2 and P3 are in an event task (execution priority: 48).
- P3 is executed in the event task.
- The PrgStop instruction with P3 specified is executed in the periodic task.
- P3 in the event task is disabled from the event task that is executed after the PrgStop instruction is executed.
- Thereafter, P3 remains disabled even if you do not execute the PrgStop instruction with P3 specified.

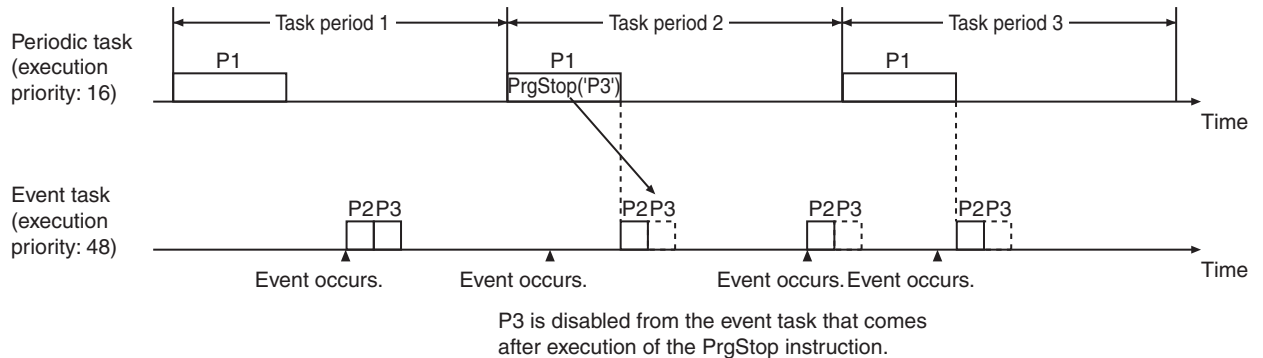

● **Disabling a Program in an Event Task with a Higher Execution Priority from a Periodic Task**

- There are three programs in this example. P1 and P2 are in an event task (execution priority: 8), and P2 is in a periodic task (execution priority: 16).
- P2 is executed in the event task.
- The PrgStop instruction with P2 specified is executed in the periodic task.
- P2 in the event task is disabled from the event task that is executed after the PrgStop instruction is executed.
- Thereafter, P2 remains disabled even if you do not execute the PrgStop instruction with P2 specified.

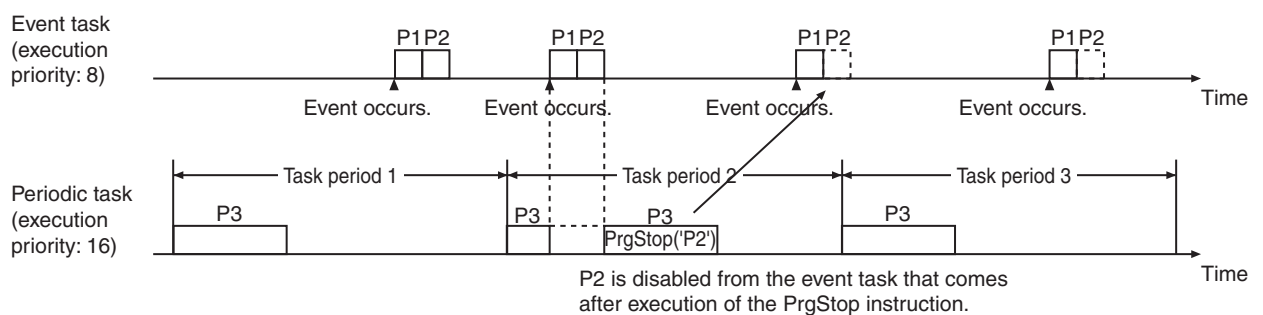

● **Disabling a Program in an Event Task with a Lower Execution Priority from an Event Task**

- There are three programs in this example. P1 is in an event task (execution priority: 8), and P2 and P3 are in an event task (execution priority: 48).
- P3 in the event task (execution priority: 48) is executed.
- The PrgStop instruction with P3 specified is executed in the event task (execution priority: 8).
- P3 in the event task (execution priority: 48) is disabled from the event task (execution priority: 48) that is executed after the PrgStop instruction is executed.
- Thereafter, P3 remains disabled even if you do not execute the PrgStop instruction with P3 specified.

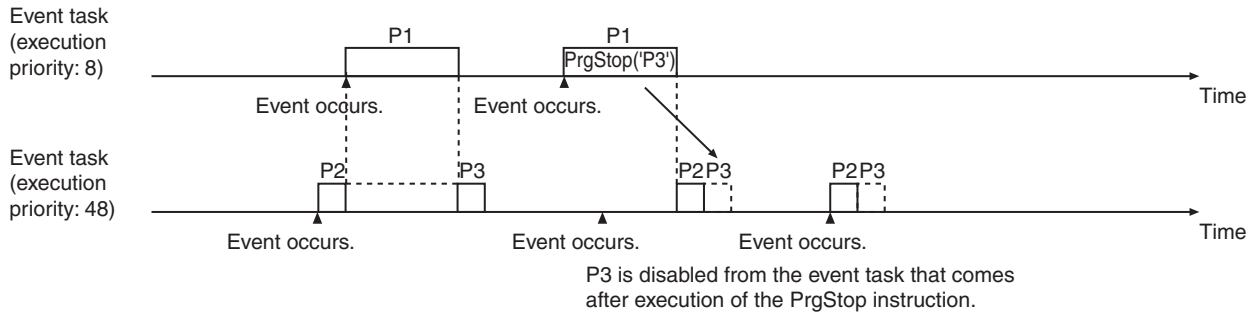

● **Disabling a Program in an Event Task with a Higher Execution Priority from an Event Task**

- There are three programs in this example. P1 and P2 are in an event task (execution priority: 8), and P3 is in an event task (execution priority: 48).
- P2 in the event task (execution priority: 8) is executed.
- The PrgStop instruction with P2 specified is executed in the event task (execution priority: 48).
- P2 in the event task (execution priority: 8) is disabled from the event task (execution priority: 8) that is executed after the PrgStop instruction is executed.
- Thereafter, P2 remains disabled even if you do not execute the PrgStop instruction with P2 specified.

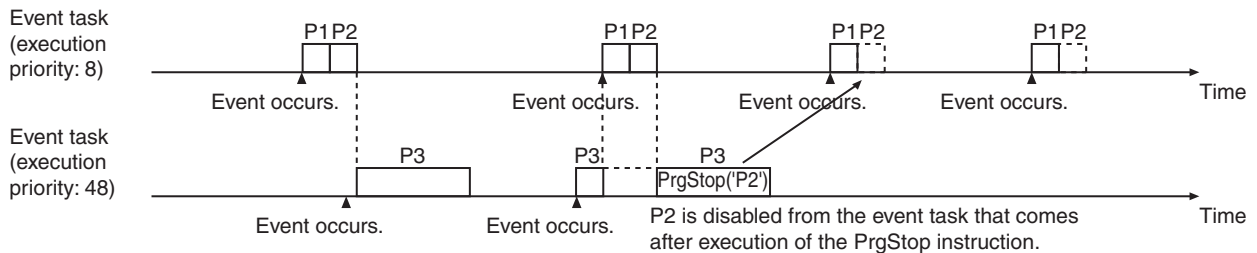

Notation Example

The following example shows the notation for specifying disabling program P1.

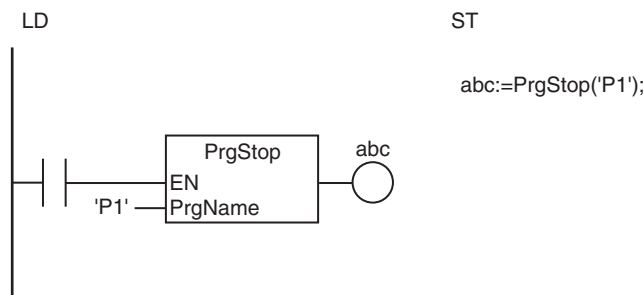

Additional Information

- Use the PrgStart instruction (page 2-890) to enable a specified program from the user program.
- Use the PrgStatus instruction (page 2-919) to read the status of a specified program from the user program.

Precautions for Correct Use

- An error will not occur even if you specify a program that is already in a disabled state and execute this instruction.
- If the PrgStop instruction is executed after executing the PrgStart instruction for the same program and it is executed before the program is actually executed, the program is not executed.
- If the PrgStart instruction is executed after executing the PrgStop instruction for the same program and it is executed before the execution timing for the program, the program is not disabled.
- Processing for instructions that have an *Execute* input variable is continued until it is completed even if the execution time exceeds the task period. Before you disable programs that have such instructions, check the values of the *Busy* output variables from the instructions first to make sure that they are FALSE (i.e., to make sure that instruction execution is not in progress).
- The execution of the NX_DOutTimeStamp or NX_AryDOutTimeStamp instruction sometimes requires more than one task. Before you disable programs that have these instructions, check the values of the *Enable* input variables to the instructions first to make sure that they are FALSE.
- The operation of the programs immediately after the operating mode of the CPU Unit changes to RUN mode is controlled by the setting of the *Initial Status* for each program on the Sysmac Studio. In other words, the results of executing the PrgStart or PrgStop instruction before changing to RUN mode are not valid.
- If this instruction is executed for a program in a different task, the timing of disabling the specified program will depend on the task execution priority of both tasks. In some cases, the Controller may perform unexpected operation. You can execute this instruction in the first program in the task to which the specified program is assigned to make sure that the specified program is disabled in the same task period as the instruction.
- Confirm the following for the specified program before you execute this instruction.
 - The execution of a motion control instruction is not still in progress.
 - Processing for instructions that have an *Execute* input variable, i.e., instructions for which execution is continued until processing is completed even if the execution time exceeds the task period, is not still in progress.
 - There are no time stamp instructions that are still waiting for the specified time.
- Program outputs are not reset when the specified program is disabled. The values from before the execution is disabled are retained. If you need to reset the outputs when the program is disabled, use master control within the specified program to reset them in advance.
- Even if you disable a program with this instruction, processing for any function block instruction with an *Execute* input variable in the program is continued to the end.
- Even if you disable a program with this instruction, processing for any motion control instructions in the program is continued to the end.
- An error will occur in the following case. *Out* will be FALSE.
 - The program specified by *PrgName* does not exist.



Version Information

A CPU Unit with unit version 1.08 or later and Sysmac Studio version 1.09 or higher are required to use this instruction.

Sample Programming

- **Example in Which One of Three Programs Is Executed in Each Consecutive Task Period**

In this example, there are three programs, P1, P2, and P3. One of each of these programs is executed in each consecutive task period and then they are repeated. Instructions are executed in the P_Main program to enable and disable these three programs.

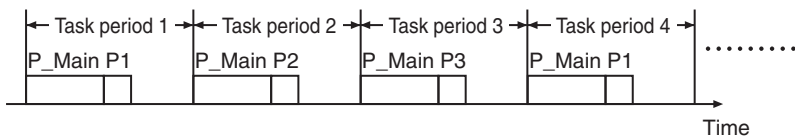

LD

Variable	Data type	Default	Comment
iStep	DINT	0	Number of program to execute

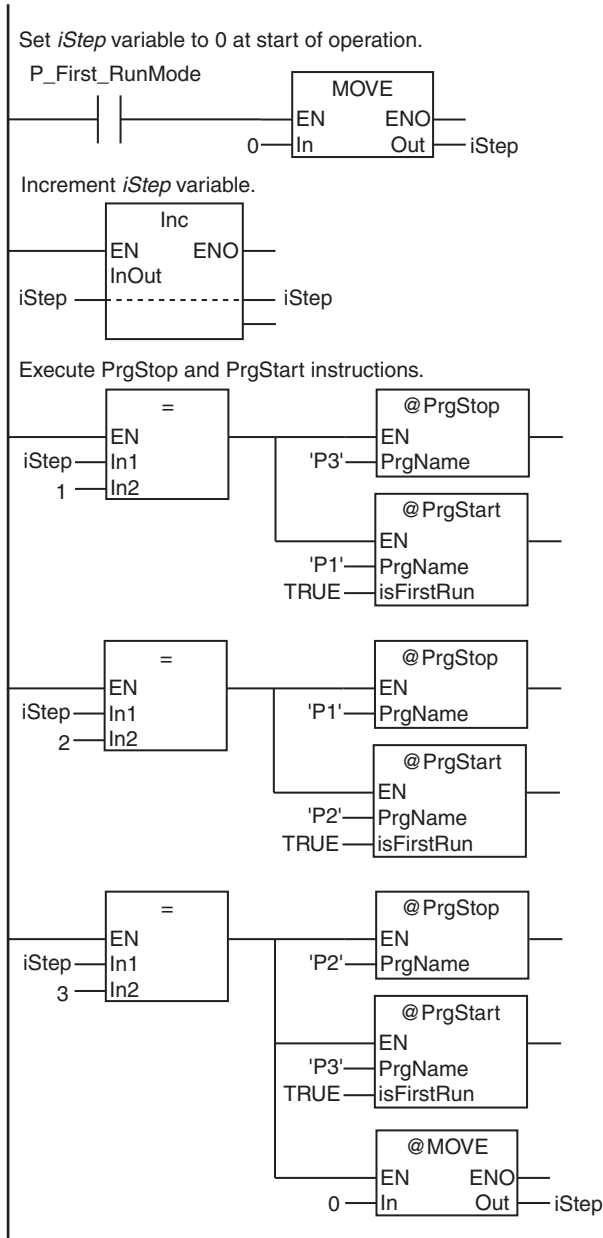

ST

Variable	Data type	Default	Comment
iStep	DINT	0	Number of program to execute

```

// Set iStep variable to 0 at start of operation.
IF P_First_RunMode THEN
  iStep:=0;
END_IF;

// Execute PrgStop and PrgStart instructions.
iStep:=iStep+1;

// PrgStop???PrgStart????
IF iStep = 1 THEN
  PrgStop('P3');
  PrgStart('P1',TRUE);
ELSIF iStep = 2 THEN
  PrgStop('P1');
  PrgStart('P2',FALSE);
ELSIF iStep = 3 THEN
  PrgStop('P2');
  PrgStart('P3',TRUE);
  iStep:=0;
END_IF;

```

● Example of Executing Only the Specified Program or Programs the Next Time Operation Starts

In this example, the program or programs to execute the next time operation starts are specified before the power supply to the Controller is turned OFF. When the power supply is next turned ON, only the specified program or programs are executed.

Programs, Modules, and Module Configuration

There are eight programs from Program 1 to Program 8.

Each program belongs to one of five modules from Module A to Module E.

Module	Programs in module
Module A	Program 1
Module B	Program 2
Module C	Program 3 and Program 4
Module D	Program 5, Program 6, and Program 7
Module E	Program 8

The programs to execute are specified by specifying a module. A combination of modules to execute is called a module configuration.

For example, if a module configuration to execute Module A and Module C was specified, Program 1, Program 3, and Program 4 would be executed.

Specifying Module Configurations to Execute

The module configurations are given with text data in a configuration file. The file name of the configuration file is Config.txt, and it is stored in the root directory of an SD Memory Card. The configuration file can contain more than one module configuration.

Before the power supply is turned OFF, a touch panel is used to specify the module configuration to execute next from the contents of the configuration file.

Format of Configuration File

The format of the configuration file is given in the following table.

Row	Contents
Row 1	Number of module configurations
Row 2 and higher	Module configuration number, Module A execution flag, ^{*1} Module B execution flag, Module C execution flag, Module D execution flag, Module E execution flag

*1 The module is executed if the flag is TRUE and not executed if the flag is FALSE.

An example of the contents of a configuration file is given below.

```
3
Config1, TRUE, TRUE, TRUE, FALSE, FALSE
Config2, TRUE, TRUE, FALSE, TRUE, FALSE
Config3, TRUE, TRUE, TRUE, FALSE, TRUE
```

This configuration file contains three configurations, Config1, Config2, and Config3. Of these, the Config1 module configuration says to execute Module A, Module B, and Module C and to not execute Module D and Module E.

Data Type Definitions

A structure called *myConfig* is defined as shown in the following table.

Structure	Variable	Data type	Offset type	Comment
▼	myConfig	STRUCT	NJ	Module configuration
	configName	STRING[32]		Module configuration name
	moduleA	BOOL		Module A execution flag
	moduleB	BOOL		Module B execution flag
	moduleC	BOOL		Module C execution flag
	moduleD	BOOL		Module D execution flag
	moduleE	BOOL		Module E execution flag

LD

Variable	Data type	Default	Retain	Comment
Open	FileOpen		---	Instance of FileOpen instruction
TopLineGetter	FileGets		---	Instance of FileGets instruction
LineGetter	FileGets		---	Instance of FileGets instruction
Close	FileClose		---	Instance of FileClose instruction
PTInput_TargetConfig-Num_Retain	USINT	0	✓	Number of the module configuration to execute next time operation starts
CurrentLineNum	USINT	1	---	Current configuration file row
TargetLineNum	USINT	0	---	Row for <i>CurrentConfig</i> in configuration file
ConfigNum	USINT	1	---	Number given in row 1 of configuration file
LineMax	USINT	3	---	Number of rows in configuration file obtained from <i>ConfigNum</i>
isOverLine	BOOL	FALSE	---	Error flag when value of <i>PTInput_TargetConfigNum_Retain</i> is larger than value of <i>LineMax</i>
Busy	BOOL	FALSE	---	Processing flag
SubDelINg	BOOL	FALSE	---	Read error end flag for <i>CurrentConfig</i>
Error	BOOL	FALSE	---	Error flag
opening	BOOL	FALSE	---	Configuration file open execution flag
myFileID	DWORD	0	---	File ID of configuration file
TopLineGetting	BOOL	FALSE	---	<i>ConfigNum</i> read execution flag
GetConfigNumDone	BOOL	FALSE	---	<i>ConfigNum</i> read done flag
SelectDone	BOOL	FALSE	---	<i>CurrentConfig</i> read done flag
reading	BOOL	FALSE	---	Configuration file row 2 or higher read execution flag
CurrentConfig	myConfig	(configName:="", moduleA:=FALSE, moduleB:=FALSE, moduleC:=FALSE, moduleD:=FALSE)	---	Module configuration to execute next time operation starts
Error_exceptOpen	BOOL	FALSE	---	Configuration file close execution flag when error occurs

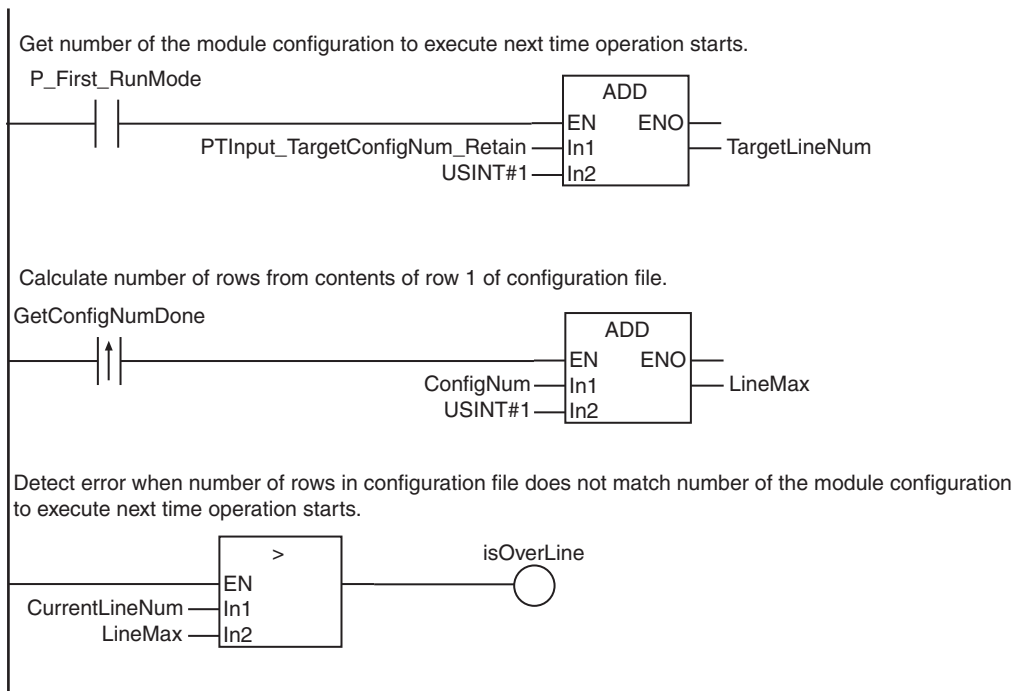

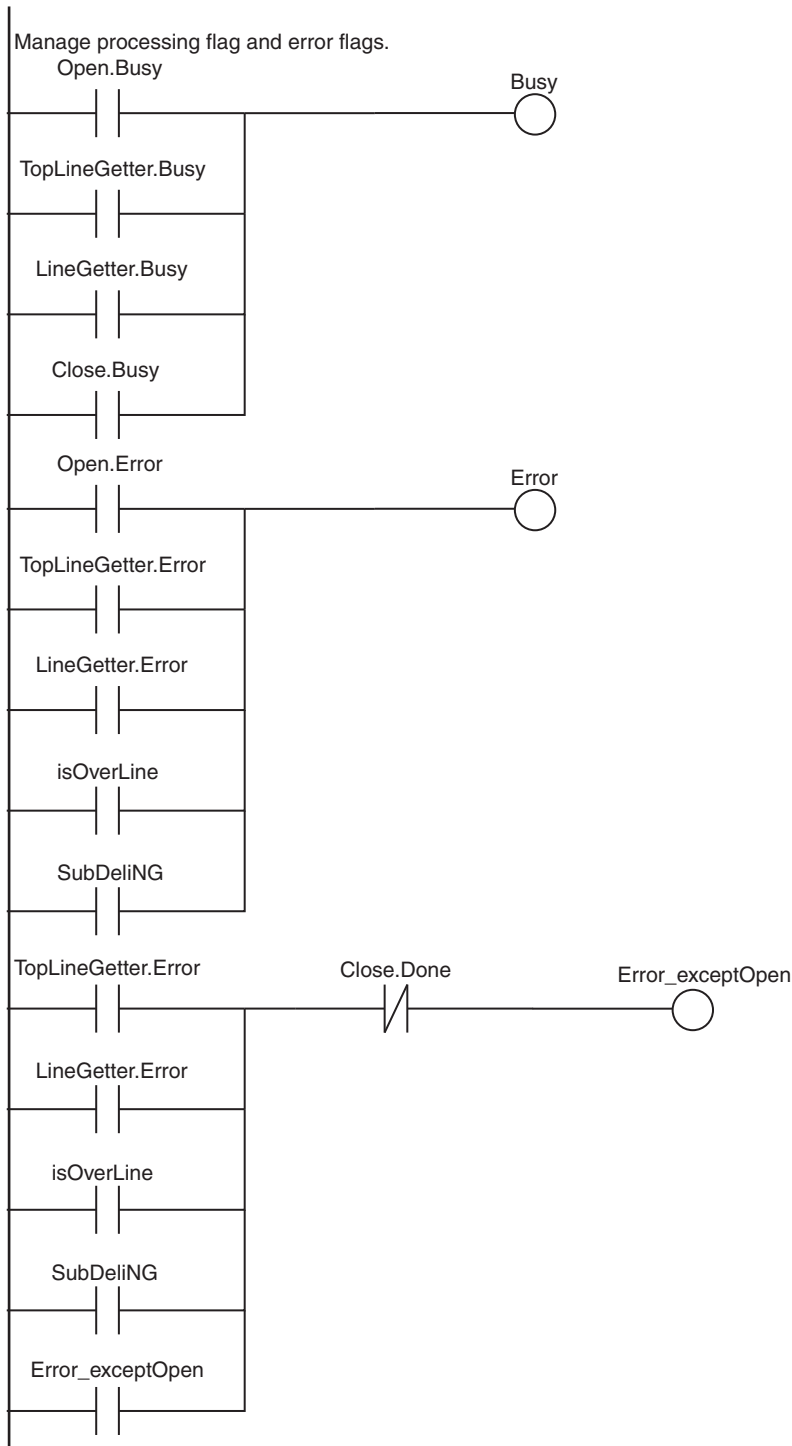

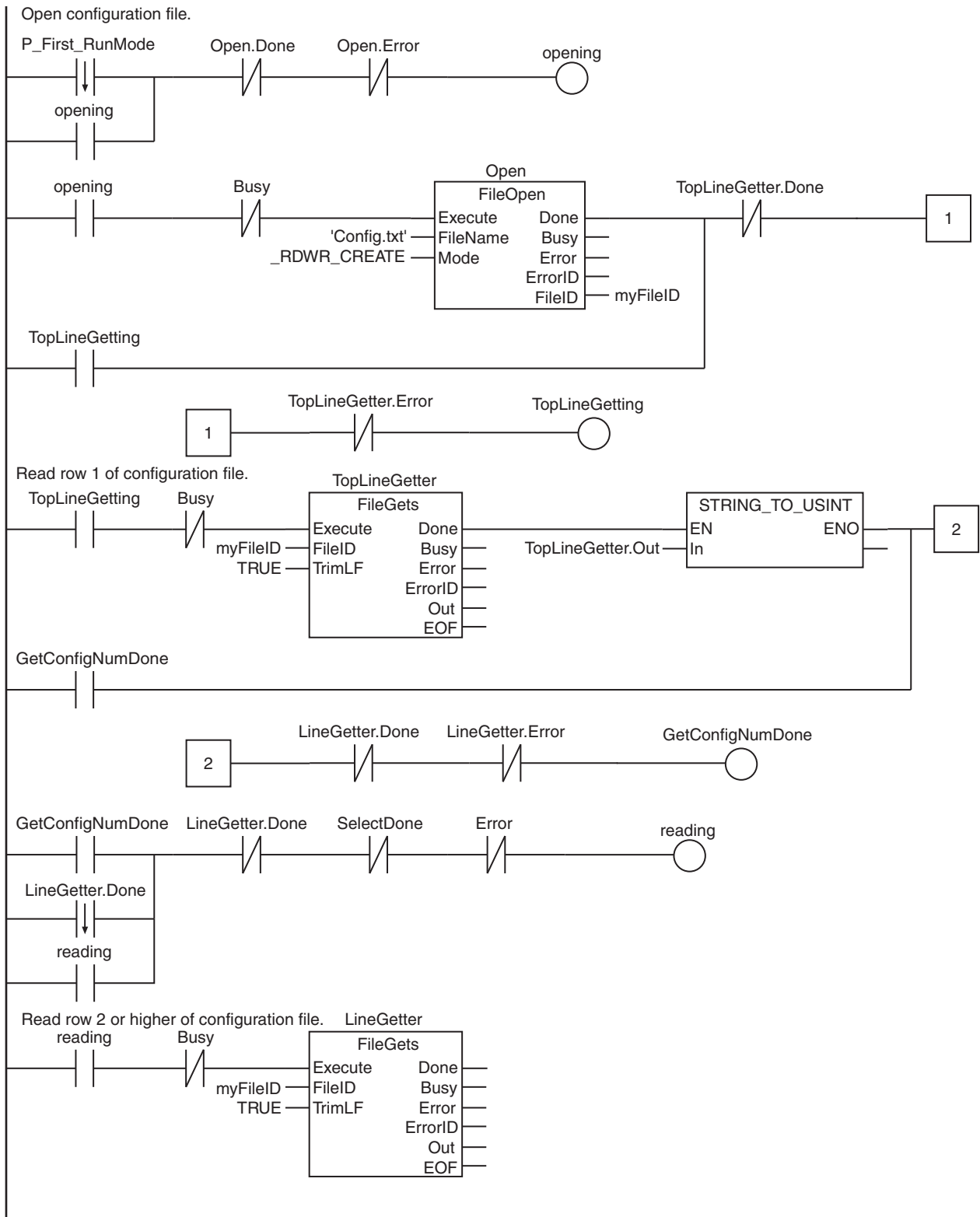

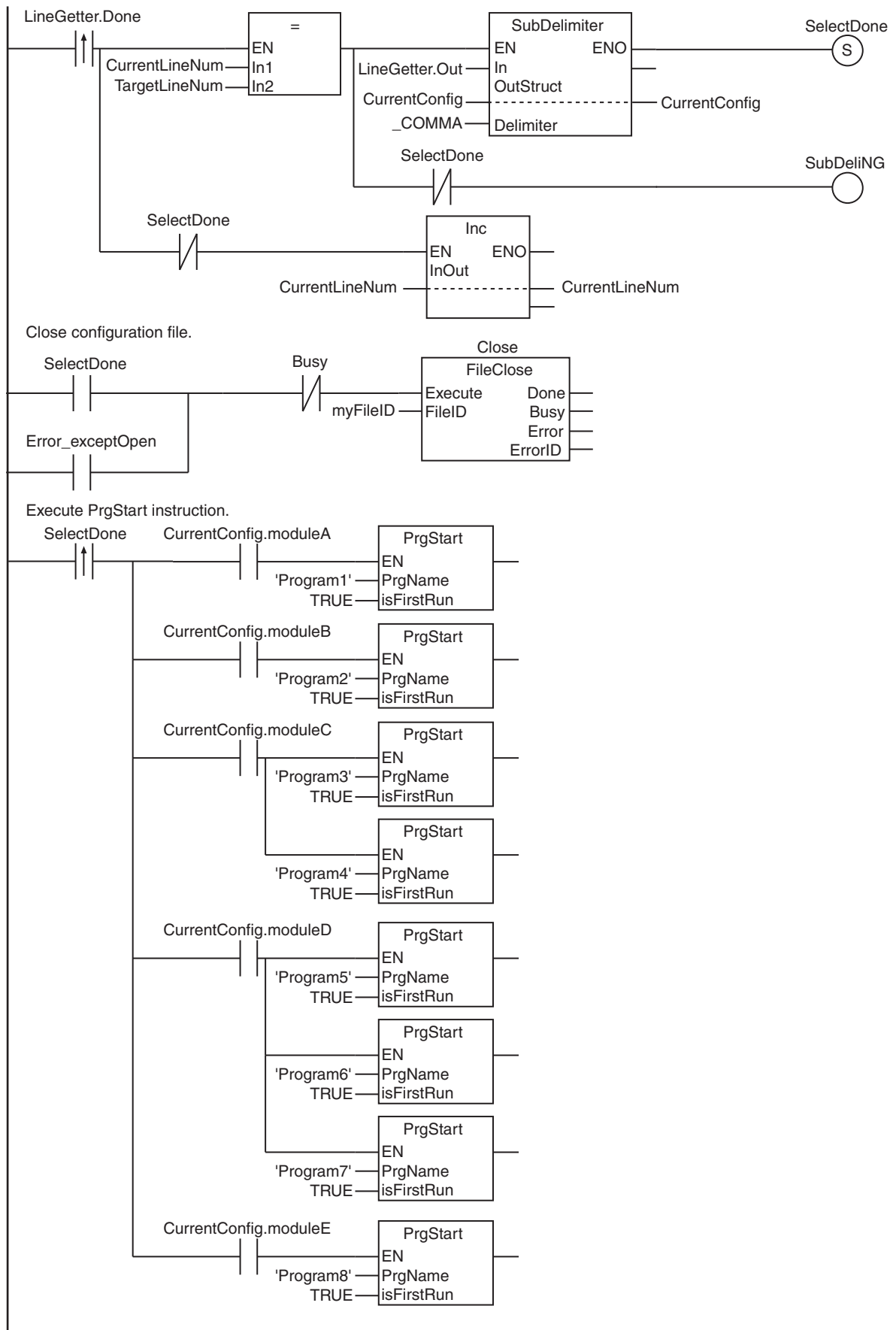

ST

Variable	Data type	Default	Retain	Comment
Open	FileOpen		---	Instance of FileOpen instruction
TopLineGetter	FileGets		---	Instance of FileGets instruction
LineGetter	FileGets		---	Instance of FileGets instruction
Close	FileClose		---	Instance of FileClose instruction
PTInput_TargetConfig-Num_Retain	USINT	0	✓	Number of the module configuration to execute next time operation starts
CurrentLineNum	USINT	1	---	Current configuration file row
TargetLineNum	USINT	0	---	Row for <i>CurrentConfig</i> in configuration file
ConfigNum	USINT	1	---	Number given in row 1 of configuration file
LineMax	USINT	3	---	Number of rows in configuration file obtained from <i>ConfigNum</i>
isOverLine	BOOL	FALSE	---	Error flag when value of <i>PTInput_TargetConfigNum_Retain</i> is larger than value of <i>LineMax</i>
Busy	BOOL	FALSE	---	Processing flag
SubDelINg	BOOL	FALSE	---	Read error end flag for <i>CurrentConfig</i>
Error	BOOL	FALSE	---	Error flag
opening	BOOL	FALSE	---	Configuration file open execution flag
myFileID	DWORD	0	---	File ID of configuration file
TopLineGetting	BOOL	FALSE	---	<i>ConfigNum</i> read execution flag
GetConfigNumDone	BOOL	FALSE	---	<i>ConfigNum</i> read done flag
SelectDone	BOOL	FALSE	---	<i>CurrentConfig</i> read done flag
reading	BOOL	FALSE	---	Configuration file row 2 or higher read execution flag
CurrentConfig	myConfig	(configName:="", moduleA:=FALSE, moduleB:=FALSE, moduleC:=FALSE, moduleD:=FALSE)	---	Module configuration to execute next time operation starts
Error_exceptOpen	BOOL	FALSE	---	Configuration file close execution flag when error occurs
R_GetConfigNumDone	R_TRIG		---	Instance of R_TRIG instruction
RS_1	RS		---	Instance of RS instruction
RS_2	RS		---	Instance of RS instruction
SecondCycle	F_TRIG		---	Instance of F_TRIG instruction
RS_3	RS		---	Instance of RS instruction
ConvertDone	BOOL	FALSE	---	Conversion done flag for converting character in row 1 of configuration file to a number.
RS_4	RS		---	Instance of RS instruction
F_LineGetterDone	F_TRIG		---	Instance of F_TRIG instruction
R_LineGetterDone	R_TRIG		---	Instance of R_TRIG instruction
isTargetLine	BOOL	FALSE	---	Flag to indicate that current row is the row of the module configuration to execute next time operation starts
SubDeliCondition	BOOL	FALSE	---	Expansion execution flag from module configuration to <i>CurrentConfig</i> .

Variable	Data type	Default	Retain	Comment
RS_5	RS		---	Instance of RS instruction
SubDeliDone	BOOL	FALSE	---	Expansion done flag from module configuration to <i>CurrentConfig</i> .
R_SelectDone	R_TRIG		---	Instance of R_TRIG instruction

```

// Get number of the module configuration to execute next time operation starts.
IF P_First_RunMode THEN
  TargetLineNum := PTInput_TargetConfigNum_Retain + USINT#1;
END_IF;

// Calculate number of rows from contents of row 1 of configuration file.
R_GetConfigNumDone(Clk:=GetConfigNumDone);
IF R_GetConfigNumDone.Q THEN
  LineMax := ConfigNum + USINT#1;
END_IF;

// Detect error when number of rows in configuration file does not match number
// of the module configuration to execute next time operation starts.
isOverLine := (CurrentLineNum > LineMax);

// Manage processing flag and error flags.
Busy := Open.Busy OR TopLineGetter.Busy OR LineGetter.Busy OR Close.Busy;

Error := Open.Error OR TopLineGetter.Error OR LineGetter.Error OR isOverLine
OR SubDelinG;

RS_1(Set:= (TopLineGetter.Error OR LineGetter.Error OR isOverLine OR SubDelinG),
reset1 := Close.Done, Q1 => Error_exceptOpen);

// Open configuration file.
SecondCycle(Clk:=P_First_RunMode);
RS_2(Set := SecondCycle.Q, reset1:=(Open.Done OR Open.Error), Q1 => opening);
Open(Execute:=(opening & NOT(Busy)), FileName :='Config.txt', FileID => myFile-
eID);
RS_3(Set := Open.Done, Reset1:=(TopLineGetter.Done OR TopLineGetter.Error),
Q1=>TopLineGetting);

// Read row 1 of configuration file.
TopLineGetter(Execute :=(TopLineGetting & NOT(Busy)), FileID := myFileID, TrimLF
:= TRUE);
ConfigNum := STRING_TO_USINT(EN:= TopLineGetter.Done, IN:=TopLineGetter.Out,
ENO=>ConvertDone);
RS_4(Set := ConvertDone, Reset1:=(LineGetter.Done OR LineGetter.Error), Q1=>Get-
ConfigNumDone);
F_LineGetterDone(Clk:=LineGetter.Done);
RS_5(Set := (GetConfigNumDone OR F_LineGetterDone.Q), Reset1:=(LineGetter.Done OR
SelectDone OR Error), Q1=>reading);

// Read row 2 or higher of configuration file.
LineGetter(Execute:=(reading & NOT(Busy)), FileID:=myFileID, TrimLF := TRUE);
R_LineGetterDone(Clk:=LineGetter.Done);
isTargetLine := (CurrentLineNum = TargetLineNum);
SubDeliCondition := (R_LineGetterDone.Q & isTargetLine);
SubDelimiter(EN := SubDeliCondition, In := LineGetter.Out, OutStruct := Current-
Config, Delimiter := _COMMA, ENO => SubDeliDone);
IF SubDeliDone THEN
  SelectDone := TRUE;
END_IF;
SubDelinG := (SubDeliCondition & NOT(SubDeliDone));
Inc(EN := (R_LineGetterDone.Q & NOT(SelectDone)), InOut:= CurrentLineNum);

```

```
// Close configuration file.
Close(Execute := ((SelectDone OR Error_exceptOpen) & NOT(Busy)), FileID := myFileID);

// Execute PrgStart instruction.
R_SelectDone(Clk:=SelectDone);
//moduleA
PrgStart(EN := (R_SelectDone.Q & CurrentConfig.moduleA), PrgName := 'Program1',
isFirstRun:=TRUE);
//moduleB
PrgStart(EN := (R_SelectDone.Q & CurrentConfig.moduleB), PrgName := 'Program2',
isFirstRun:=TRUE);
//moduleC
PrgStart(EN := (R_SelectDone.Q & CurrentConfig.moduleC), PrgName := 'Program3',
isFirstRun:=TRUE);
PrgStart(EN := (R_SelectDone.Q & CurrentConfig.moduleC), PrgName := 'Program4',
isFirstRun:=TRUE);
//moduleD
PrgStart(EN := (R_SelectDone.Q & CurrentConfig.moduleD), PrgName := 'Program5',
isFirstRun:=TRUE);
PrgStart(EN := (R_SelectDone.Q & CurrentConfig.moduleD), PrgName := 'Program6',
isFirstRun:=TRUE);
PrgStart(EN := (R_SelectDone.Q & CurrentConfig.moduleD), PrgName := 'Program7',
isFirstRun:=TRUE);
//moduleE
PrgStart(EN := (R_SelectDone.Q & CurrentConfig.moduleE), PrgName := 'Program8',
isFirstRun:=TRUE);
```

PrgStatus

The PrgStatus instruction reads the status of the specified program.

Instruction	Name	FB/FUN	Graphic expression	ST expression
PrgStatus	Read Program Status	FUN		Out:=PrgStatus(PrgName);

Variables

Name	Meaning	I/O	Description	Valid range	Unit	Default
PrgName	Program name	Input	Name of specified program	128 bytes max. (127 single-byte alphanumeric characters plus the final NULL character)	---	*1
Out	Program status	Output	Status of program the next time the timing for execution occurs TRUE: Enabled. FALSE: Disabled.	Depends on data type.	---	---

*1 If you omit an input parameter, the default value is not applied. A building error will occur.

	Boolean	Bit strings					Integers						Real numbers		Times, durations, dates, and text strings					
	BOOL	BYTE	WORD	DWORD	LWORD	USINT	UINT	UDINT	ULINT	SINT	INT	DINT	LINT	REAL	LREAL	TIME	DATE	TOD	DT	STRING
PrgName																				OK
Out	OK																			

Function

The PrgStatus instruction reads the status of the program specified with *PrgName* for the next time the timing for executing the program occurs. The value of *Out* is TRUE if the specified program will be enabled the next time the timing for executing it occurs. The value of *Out* is FALSE if the specified program will be disabled the next time the timing for executing it occurs.

The following table shows the meaning of “enabled” and “disabled” for the next time the timing for executing a program occurs.

Program status	Description
Enabled the next time the timing for execution occurs	<ul style="list-style-type: none"> The <i>Initial Status</i> for the relevant program is set to <i>Run</i> on the Sysmac Studio. The PrgStart instruction was executed for the program.
Disabled the next time the timing for execution occurs	<ul style="list-style-type: none"> The <i>Initial Status</i> for the relevant program is set to <i>Stop</i> on the Sysmac Studio. The PrgStop instruction was executed for the program.

The specified program can be in the same task as this instruction, or it can be in a different task.

Operation Example

This section provides some examples of the operation of this instruction.

● Reading the Status of a Program After the PrgStatus Instruction in the Current Task

- In this example, there are two programs, P1 and P2, in the same task.
- The PrgStop instruction with P2 specified is executed in P1 of task period 1.
- The PrgStatus instruction with P2 specified is then executed in P1 of task period 1.
- P2 was disabled for task period 1, so the value of *Out* from the PrgStatus instruction is FALSE.

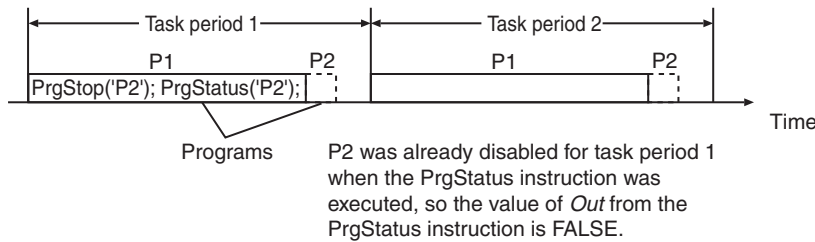

● Reading the Status of a Program Before the PrgStatus Instruction in the Current Task

- In this example, there are two programs, P1 and P2, in the same task.
- The PrgStart instruction with P1 specified is executed in P2 of task period 1.
- The PrgStatus instruction with P1 specified is then executed in P2 of task period 1.
- P1 was enabled for task period 2, so the value of *Out* from the PrgStatus instruction is TRUE.

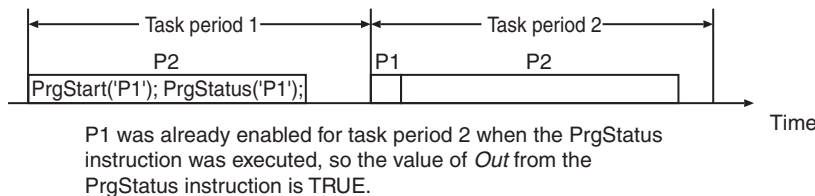

● Reading the Status of the Program That Includes the PrgStatus Instruction

- The PrgStop instruction with P1 specified is executed in P1 of task period 1.
- The PrgStatus instruction with P1 specified is then executed in P1 of task period 1.
- P1 was disabled for task period 2, so the value of *Out* from the PrgStatus instruction is FALSE.

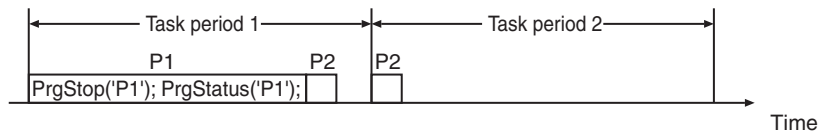

P1 was already disabled for task period 2 when the PrgStatus instruction was executed, so the value of *Out* from the PrgStatus instruction is FALSE.

Notation Example

The following example shows the notation for reading the status of the P1 program.

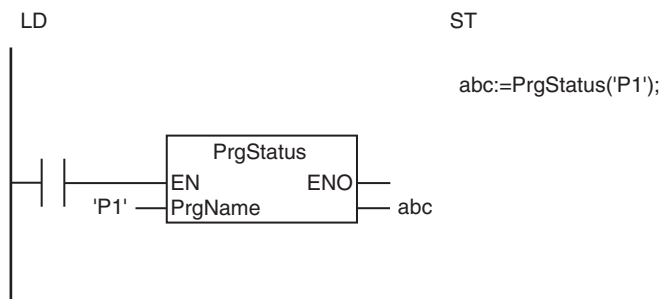

Additional Information

- Use the PrgStart instruction (page 2-890) to enable a specified program from the user program.
- Use the PrgStop instruction (page 2-899) to disable a specified program from the user program.

Precautions for Correct Use

- An error will occur in the following case. *Out* will be FALSE.
 - The program specified by *PrgName* does not exist.



Version Information

A CPU Unit with unit version 1.08 or later and Sysmac Studio version 1.09 or higher are required to use this instruction.

Sample Programming

In this example, there are three programs, P1, P2, and P3. Operations on a touch panel are used to change the program to execute.

Touch Panel Specifications

This example assumes that a touch panel is connected to the Controller.

The touch panel has the following lamps.

Lamp name	Description
P1 executing lamp	Lit when P1 execution is in progress.
P2 executing lamp	Lit when P2 execution is in progress.
P3 executing lamp	Lit when P3 execution is in progress.

The touch panel also has the following buttons.

Button name	Operation when button is pressed
Execution program change button	Each time this button is pressed, the program to execute changes in order from P1 to P2 to P3, and then returns to P1.

Global Variables

Variable	Data type	Initial value	Comment
PTIn_Type	INT	0	Execution program change button input
PTOut_P1Status	BOOL	FALSE	P1 executing lamp output
PTOut_P2Status	BOOL	FALSE	P2 executing lamp output
PTOut_P3Status	BOOL	FALSE	P3 executing lamp output

LD

External Variables	Variable	Data type	Comment
	PTIn_Type	INT	Execution program change button input
	PTOut_P1Status	BOOL	P1 executing lamp output
	PTOut_P2Status	BOOL	P2 executing lamp output
	PTOut_P3Status	BOOL	P3 executing lamp output

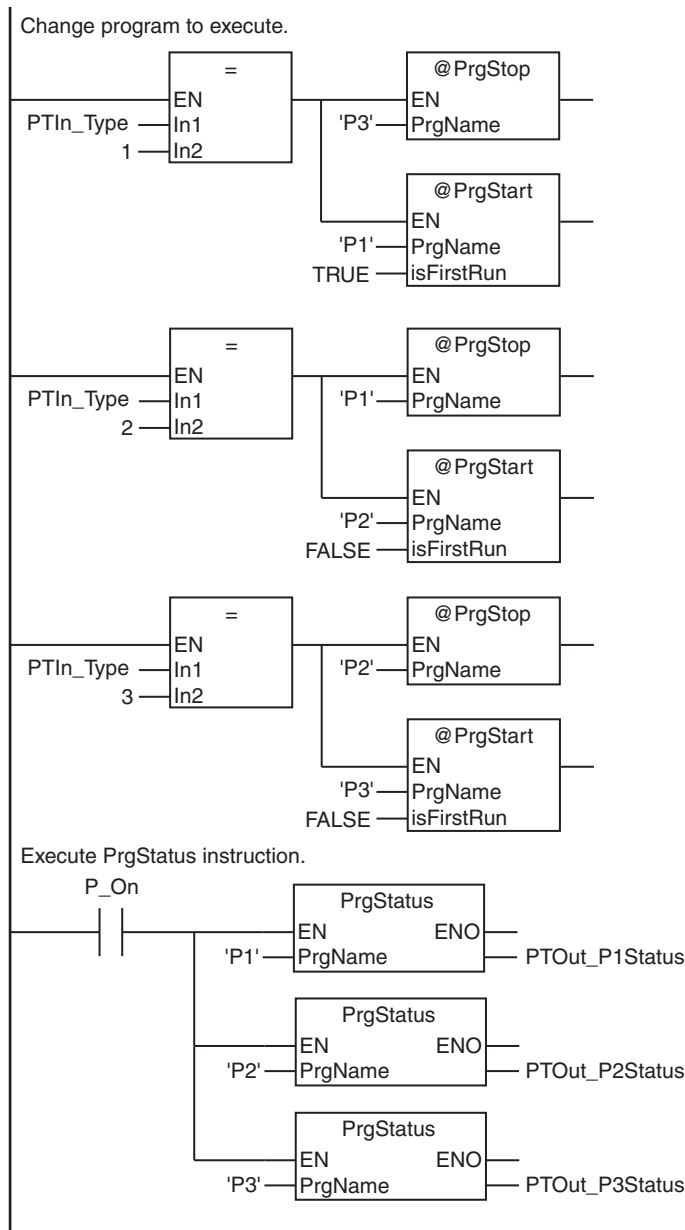

ST

External Variables	Variable	Data type	Comment
	PTIn_Type	INT	Execution program change button input
	PTOut_P1Status	BOOL	P1 executing lamp output
	PTOut_P2Status	BOOL	P2 executing lamp output
	PTOut_P3Status	BOOL	P3 executing lamp output

```

// Change program to execute.
IF PTIn_Type = 1 THEN
  PrgStop('P3');
  PrgStart('P1', TRUE);
ELSIF PTIn_Type = 2 THEN
  PrgStop('P1');
  PrgStart('P2', FALSE);
ELSIF PTIn_Type = 3 THEN
  PrgStop('P2');
  PrgStart('P3', FALSE);
END_IF;

// Execute PrgStatus instruction.
IF P_On THEN
  PTOut_P1Status:=PrgStatus('P1');
  PTOut_P2Status:=PrgStatus('P2');
  PTOut_P3Status:=PrgStatus('P3');
END_IF;

```

EtherCAT Communications Instructions

Instruction	Name	Page
EC_CoESDOWrite	Write EtherCAT CoE SDO	2-926
EC_CoESDORead	Read EtherCAT CoE SDO	2-929
EC_StartMon	Start EtherCAT Packet Monitor	2-934
EC_StopMon	Stop EtherCAT Packet Monitor	2-940
EC_SaveMon	Save EtherCAT Packets	2-942
EC_CopyMon	Transfer EtherCAT Packets	2-944
EC_DisconnectSlave	Disconnect EtherCAT Slave	2-946
EC_ConnectSlave	Connect EtherCAT Slave	2-953
EC_ChangeEnableSetting	Enable/Disable EtherCAT Slave	2-955
NX_WriteObj	Write NX Unit Object	2-972
NX_ReadObj	Read NX Unit Object	2-987

EC_CoESDOWrite

The EC_CoESDOWrite instruction writes a value to a CoE* object of a specified slave on an EtherCAT network.

Instruction	Name	FB/ FUN	Graphic expression	ST expression
EC_CoES- DOWrite	Write EtherCAT CoE SDO	FB	<pre> graph LR subgraph EC_CoESDOWrite_instance [EC_CoESDOWrite_instance] EC_CoESDOWrite[EC_CoESDOWrite] end Execute --- EC_CoESDOWrite NodeAdr --- EC_CoESDOWrite SdoObj --- EC_CoESDOWrite TimeOut --- EC_CoESDOWrite WriteDat --- EC_CoESDOWrite WriteSize --- EC_CoESDOWrite EC_CoESDOWrite --- Done EC_CoESDOWrite --- Busy EC_CoESDOWrite --- Error EC_CoESDOWrite --- ErrorID EC_CoESDOWrite --- AbortCode </pre>	EC_CoESDOWrite_instance(Execute, NodeAdr, SdoObj, TimeOut, WriteDat, WriteSize, Done, Busy, Error, ErrorID, AbortCode);

* CoE stands for CAN Application Protocol over EtherCAT.

Variables

Name	Meaning	I/O	Description	Valid range	Unit	Default
NodeAdr	Slave node address	Input	Node address of the slave to access	1 to 512*1	---	---
SdoObj	SDO parameter		SDO parameter	---	---	---
TimeOut	Timeout time		0: 2.0s 1 to 65535: 0.1 to 6553.5 s	Depends on data type.	0.1 s	20 (2.0 s)
WriteDat	Write data		Write data		---	---
WriteSize	Write data size		Write data size*2	1 to 2048	Bytes	---
AbortCode	Abort code	Output	Response code for SDO access specified by CoE 0: Normal end	Depends on data type.	---	---

*1 The range is 1 to 192 for an NJ-series CPU Unit.

*2 The write data size may be less than 1 byte, e.g., if the write data is BOOL or a BOOL array. If it is less than 1 byte, set the value of *WriteSize* to 1.

	Boolean	Bit strings					Integers							Real numbers	Times, durations, dates, and text strings					
	BOOL	BYTE	WORD	DWORD	LWORD	USINT	UINT	UDINT	ULINT	SINT	INT	DINT	LINT	REAL	LREAL	TIME	DATE	TOD	DT	STRING
NodeAdr							OK													
SdoObj	Refer to <i>Function</i> for details on the structure <code>_sSDO_ACCESS</code> .																			
TimeOut							OK													
WriteDat	OK	OK	OK	OK	OK	OK	OK	OK	OK	OK	OK	OK	OK	OK	OK	OK	OK	OK	OK	OK
	An enumeration, array, array element, structure member, or union member can also be specified.																			
WriteSize							OK													
AbortCode				OK																

Function

The EC_CoESDOWrite instruction writes data to the CoE object of the node specified with slave node address *NodeAdr*. The content of *WriteDat* is written to the object. The number of bytes of data to write is specified with *WriteSize*. The SDO parameter is specified with *SdoObj*.

The data type of *SdoObj* is structure `_sSDO_ACCESS`. The specifications are as follows:

Name	Meaning	Description	Data type	Valid range	Unit	Default
SdoObj	SDO parameter	SDO parameter	<code>_sSDO_ACCESS</code>	---	---	---
Index	Index	Index number in the object dictionary defined in CoE	UINT	1 to 65535		
Subindex	Subindex	Subindex number in the object dictionary defined in CoE	USINT			
IsCompleteAccess	Complete access	Specification of complete access of SDO TRUE: Access data for all subindexes FALSE: Access data for the specified subindex	BOOL	Depends on data type.	---	---

After the write is completed, the instruction waits for the response for the time specified with timeout time *TimeOut*. The response is stored in *AbortCode*. *AbortCode* is 0 for a normal response. A value is stored in *AbortCode* only when the value of *ErrorID* is 16#1804 (SDO abort response).

The meaning and values of *AbortCode* depend on the slave. Refer to the manual for the slave.

The following figure shows a timing chart. A value is stored in *AbortCode* when *Busy* changes to FALSE after the completion of instruction processing.

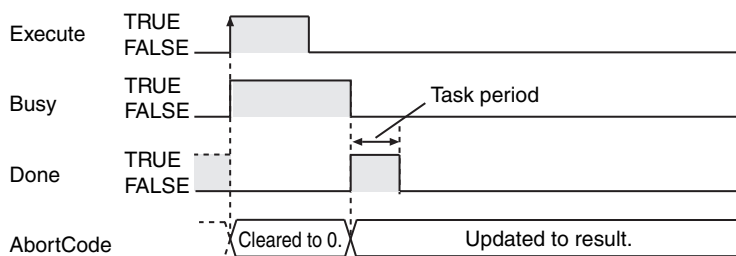

Related System-defined Variables

Name	Meaning	Data type	Description
<code>_EC_MBXSlavTbl[i]</code> "i" is the node address.	Message Communications Enabled Slave Table	BOOL	This variable indicates whether communications are possible for each slave. TRUE: Communications are possible. FALSE: Communications are not possible.

Additional Information

- Refer to the *NJ/NX-series CPU Unit Built-in EtherCAT Port User's Manual* (Cat. No. W505) or *NY-series Industrial Panel PC / Industrial Box PC Built-in EtherCAT Port User's Manual* (Cat. No. W562) for details on EtherCAT communications.
- Refer to *A-6 SDO Abort Codes* on page A-215 for the SDO abort codes.

Precautions for Correct Use

- Always use a variable for the input parameter to pass to *WriteDat*. A building error will occur if a constant is passed.
- Execution of this instruction is continued until processing is completed even if the value of *Execute* changes to FALSE or the execution time exceeds the task period. The value of *Done* changes to TRUE when processing is completed. Use this to confirm normal completion of processing.
- Refer to *Using this Section* on page 2-3 for a timing chart for *Execute*, *Done*, *Busy*, and *Error*.
- This instruction can be used only for the NJ/NX-series and NY-series Controller EtherCAT ports.
- You can execute a maximum of 32 of the following instructions at the same time:
EC_CoESDOWrite, EC_CoESDORead, EC_StartMon, EC_StopMon, EC_SaveMon, EC_CopyMon, EC_DisconnectSlave, EC_ConnectSlave, EC_ChangeEnableSetting, IOL_ReadObj, and IOL_WriteObj.
- An error occurs in the following cases. *Error* will change to TRUE.
 - The EtherCAT master is not in a state that allows message communications.
 - The slave specified with *NodeAdr* does not exist.
 - The slave specified with *NodeAdr* is not in a state that allows communications.
 - The slave returns an error response.
 - More than 32 of the following instructions were executed at the same time:
EC_CoESDOWrite, EC_CoESDORead, EC_StartMon, EC_StopMon, EC_SaveMon, EC_CopyMon, EC_DisconnectSlave, EC_ConnectSlave, EC_ChangeEnableSetting, IOL_ReadObj, and IOL_WriteObj.

EC_CoESDORead

The EC_CoESDORead instruction reads a value from a CoE* object of a specified slave on an EtherCAT network.

Instruction	Name	FB/ FUN	Graphic expression	ST expression
EC_CoES- DORead	Read EtherCAT CoE SDO	FB		EC_CoESDORead_instance(Execute, NodeAdr, SdoObj, TimeOut, ReadDat, Done, Busy, Error, ErrorID, AbortCode, ReadSize);

* CoE stands for CAN Application Protocol over EtherCAT.

Variables

Name	Meaning	I/O	Description	Valid range	Unit	Default
NodeAdr	Slave node address	Input	Node address of the slave to access	1 to 512* ¹	---	---
SdoObj	SDO parameter		SDO parameter	---	---	---
TimeOut	Timeout time		0: 2.0s 1 to 65535: 0.1 to 6553.5 s	Depends on data type.	0.1 s	0 (2.0 s)
AbortCode	Abort code	Output	Response code for SDO access specified by CoE 0: Normal end	Depends on data type.	---	---
ReadSize	Read data size		Size of data stored in <i>ReadDat</i> after the data is read* ²		Bytes	---
ReadDat	Read data	In-out	Read data buffer	Depends on data type.	---	---

*¹ The range is 1 to 192 for an NJ-series CPU Unit.

*² The read data size may be less than 1 byte, e.g., if the read data is BOOL or a BOOL array. If it is less than 1 byte, set the value of *ReadSize* to 1.

	Boolean	Bit strings					Integers							Real numbers	Times, durations, dates, and text strings					
	BOOL	BYTE	WORD	DWORD	LWORD	USINT	UINT	UDINT	ULINT	SINT	INT	DINT	LINT	REAL	LREAL	TIME	DATE	TOD	DT	STRING
NodeAdr							OK													
SdoObj	Refer to <i>Function</i> for details on the structure <i>_sSDO_ACCESS</i> .																			
TimeOut							OK													
AbortCode				OK																
ReadSize							OK													
ReadDat	OK	OK	OK	OK	OK	OK	OK	OK	OK	OK	OK	OK	OK	OK	OK	OK	OK	OK	OK	OK
	An enumeration, array, array element, structure member, or union member can also be specified.																			

Function

The EC_CoESDORead instruction reads data from the CoE object of the node specified with slave node address *NodeAdr*. The read data is stored in *ReadDat*. Then size of data that was stored is stored in *ReadSize*. The value of *ReadSize* is valid only when the data was stored successfully. The SDO parameter is specified with *SdoObj*.

The data type of *SdoObj* is structure *_sSDO_ACCESS*. The specifications are as follows:

Name	Meaning	Description	Data type	Valid range	Unit	Default
SdoObj	SDO parameter	SDO parameter	<i>_sSDO_ACCESS</i>	---	---	---
Index	Index	Index number in the object dictionary defined in CoE	UINT	1 to 65535	---	---
Subindex	Subindex	Subindex number in the object dictionary defined in CoE	USINT	Depends on data type.		
IsCompleteAccess	Complete access	Specification of complete access of SDO TRUE: Access data for all subindexes FALSE: Access data for the specified subindex	BOOL			

After the read is completed, the instruction waits for the response for the time specified with timeout time *TimeOut*. The response is stored in *AbortCode*. *AbortCode* is 0 for a normal response. A value is stored in *AbortCode* only when the value of *ErrorID* is 16#1804 (SDO abort response).

The meaning and values of *AbortCode* depend on the slave. Refer to the manual for the slave.

The following figure shows a timing chart. A value is stored in *AbortCode* when *Busy* changes to FALSE after the completion of instruction processing.

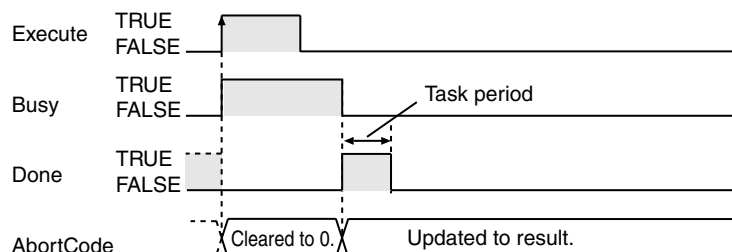

Related System-defined Variables

Name	Meaning	Data type	Description
<i>_EC_MBXSlaveTbl[i]</i> "i" is the node address.	Message Communications Enabled Slave Table	BOOL	This variable indicates whether communications are possible for each slave. TRUE: Communications are possible. FALSE: Communications are not possible.

Additional Information

- Refer to the *NJ/NX-series CPU Unit Built-in EtherCAT Port User's Manual* (Cat. No. W505) or *NY-series Industrial Panel PC / Industrial Box PC Built-in EtherCAT Port User's Manual* (Cat. No. W562) for details on EtherCAT communications.
- Refer to *A-6 SDO Abort Codes* on page A-215 for the SDO abort codes.

Precautions for Correct Use

- Execution of this instruction is continued until processing is completed even if the value of *Execute* changes to FALSE or the execution time exceeds the task period. The value of *Done* changes to TRUE when processing is completed. Use this to confirm normal completion of processing.
- Refer to *Using this Section* on page 2-3 for a timing chart for *Execute*, *Done*, *Busy*, and *Error*.
- This instruction can be used only for the NJ/NX-series and NY-series Controller EtherCAT ports.
- You can execute a maximum of 32 of the following instructions at the same time: EC_CoESDOWrite, EC_CoESDORead, EC_StartMon, EC_StopMon, EC_SaveMon, EC_CopyMon, EC_DisconnectSlave, EC_ConnectSlave, EC_ChangeEnableSetting, IOL_ReadObj, and IOL_WriteObj.
- An error occurs in the following cases. *Error* will change to TRUE.
 - The EtherCAT master is not in a state that allows message communications.
 - The slave specified with *NodeAdr* does not exist.
 - The slave specified with *NodeAdr* is not in a state that allows communications.
 - The slave returns an error response.
 - The read data size is larger than the size of *ReadDat*.
 - More than 32 of the following instructions were executed at the same time: EC_CoESDOWrite, EC_CoESDORead, EC_StartMon, EC_StopMon, EC_SaveMon, EC_CopyMon, EC_DisconnectSlave, EC_ConnectSlave, EC_ChangeEnableSetting, IOL_ReadObj and IOL_WriteObj.

Sample Programming

This sample uses an EtherCAT SDO message to read the software version of an OMRON 1S-series Servo Drive. The node address of the slave is 1.

The object index for the software version is 16#100A. The subindex is 0. The read value is stored in STRING variable *VersionInfo*.

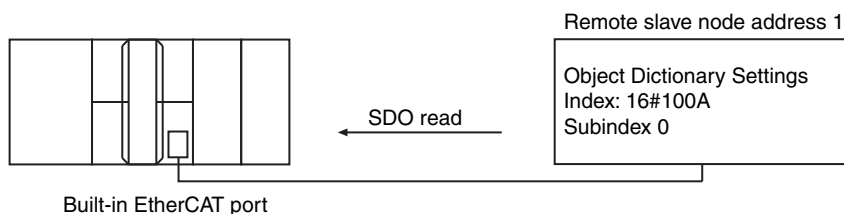

LD

Internal Variables	Variable	Data type	Initial value	Comment
	Trigger	BOOL	FALSE	Execution condition
	SdoObject	_sSDO_ACCESS	(Index:=0, Subindex:=0, IsCompleteAccess:=FALSE)	SDO parameter
	VersionInfo	STRING[256]	"	Read data
	EC_CoESDORead_instance	EC_CoESDORead		

External Variables	Variable	Data type	Constant	Comment
	_EC_MBXSlavTbl	ARRAY[1..512] OF BOOL*1	✓	Message Communications Enabled Slave Table

*1 The data type is ARRAY [1..192] OF BOOL for an NJ-series CPU Unit.

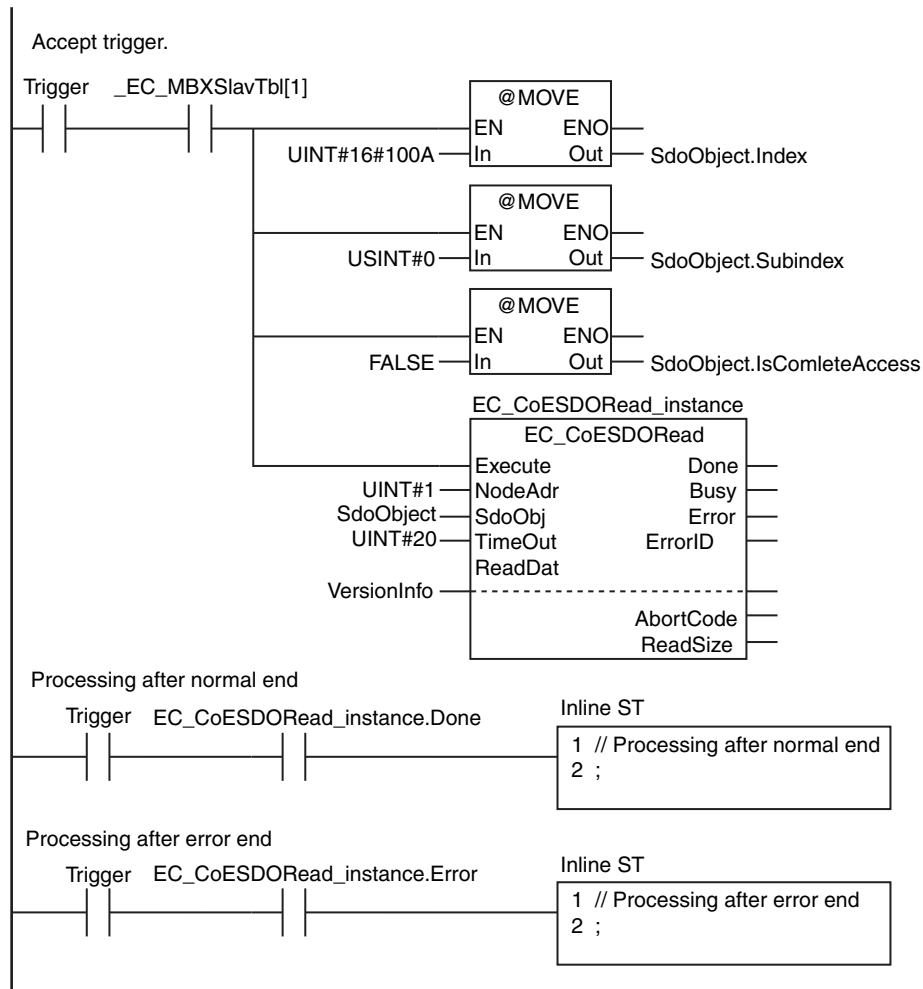

ST

Internal Variables	Variable	Data type	Initial value	Comment
	Trigger	BOOL	FALSE	Execution condition
	SdoObject	_sSDO_ACCESS	(Index:=0, Subindex:=0, IsCompleteAccess:=FALSE)	SDO parameter
	DoSdoRead	BOOL	FALSE	Processing
	VersionInfo	STRING[256]	"	Read data
	NormalEnd	UINT	0	Normal end
	ErrorEnd	UINT	0	Error end
	EC_CoESDORead_instance	EC_CoESDORead		

External Variables	Variable	Data type	Constant	Comment
	_EC_MBXSlavTbl	ARRAY[1..192] OF BOOL *1	✓	Message Communications Enabled Slave Table

*1 The data type is ARRAY [1..192] OF BOOL for an NJ-series CPU Unit.

```
// Detect when Trigger changes to TRUE.
IF ( (Trigger=TRUE) AND (DoSdoRead=FALSE) AND (_EC_MBXSlavTbl[1]=TRUE) ) THEN
  DoSdoRead :=TRUE;
  SdoObject.Index :=UINT#16#100A;
  SdoObject.Subindex :=USINT#0;
  SdoObject.IsCompleteAccess:=FALSE;
  EC_CoESDORead_instance(
    Execute:=FALSE, // Initialize instance.
    ReadDat:=VersionInfo); // Dummy
END_IF;

// Execute EC_CoESDORead instruction.
IF (DoSdoRead=TRUE) THEN
  EC_CoESDORead_instance(
    Execute :=TRUE,
    NodeAdr :=UINT#1, // Node address 1
    SdoObj :=SdoObject, // SDO parameter
    TimeOut :=UINT#20, // Timeout time: 2.0 s
    ReadDat :=VersionInfo); // Read data

  IF (EC_CoESDORead_instance.Done=TRUE) THEN
    // Processing after normal end
    NormalEnd:=NormalEnd+UINT#1;
  ELSIF (EC_CoESDORead_instance.Error=TRUE) THEN
    // Processing after error end
    ErrorEnd :=ErrorEnd+UINT#1;
  END_IF;
END_IF;
```

EC_StartMon

The EC_StartMon instruction starts execution of packet monitoring for EtherCAT communications.

Instruction	Name	FB/ FUN	Graphic expression	ST expression
EC_StartMon	Start EtherCAT Packet Monitor	FB		EC_SatrtMon_instance(Execute, Done, Busy, Error, ErrorID);

Variables

Only common variables are used.

Function

The EC_StartMon instruction starts execution of packet monitoring for EtherCAT communications. The packet monitor function collects a specified number of the most recent EtherCAT communications packets. When the specified number of packets is exceeded, old packets are discarded in order. After the EC_StartMon instruction is executed, packet monitoring continues until the EC_StopMon instruction is executed.

Related System-defined Variables

Name	Meaning	Data type	Description
_EC_PktMonStop	Packet Monitoring Stopped	BOOL	This variable shows if packet monitoring is stopped. TRUE: Stopped. FALSE: Not stopped.
_EC_PktSaving	Saving Packet Data File	BOOL	This variable shows if the instruction is saving packet data in an internal file in the main memory of the CPU Unit. TRUE: Saving. FALSE: Not saving.

Additional Information

- You cannot save collected packet data in an internal file of the main memory of the CPU Unit during ECATStartMonitor execution.
- Do the following to save packet data in an internal file in the main memory of the CPU Unit: First, execute the EC_StopMon instruction to stop packet monitoring. Then execute the EC_SaveMon instruction to save the packets.
- Refer to the *NJ/NX-series CPU Unit Built-in EtherCAT Port User's Manual* (Cat. No. W505) or *NY-series Industrial Panel PC / Industrial Box PC Built-in EtherCAT Port User's Manual* (Cat. No. W562) for details on EtherCAT communications.

Precautions for Correct Use

- Execution of this instruction is continued until processing is completed even if the value of *Execute* changes to FALSE or the execution time exceeds the task period. The value of *Done* changes to TRUE when processing is completed. Use this to confirm normal completion of processing.
- Refer to *Using this Section* on page 2-3 for a timing chart for *Execute*, *Done*, *Busy*, and *Error*.
- This instruction can be used only for the NJ/NX-series and NY-series Controller EtherCAT ports.
- You can execute a maximum of 32 of the following instructions at the same time: EC_CoESDOWrite, EC_CoESDORead, EC_StartMon, EC_StopMon, EC_SaveMon, EC_CopyMon, EC_DisconnectSlave, EC_ConnectSlave, EC_ChangeEnableSetting, IOL_ReadObj, and IOL_WriteObj.
- An error occurs in the following case. *Error* will change to TRUE.
 - A packet data save operation to an internal file in the main memory of the CPU Unit is in progress.
 - More than 32 of the following instructions were executed at the same time: EC_CoESDOWrite, EC_CoESDORead, EC_StartMon, EC_StopMon, EC_SaveMon, EC_CopyMon, EC_DisconnectSlave, EC_ConnectSlave, EC_ChangeEnableSetting, IOL_ReadObj and IOL_WriteObj.



Version Information

Depending on the unit version of the CPU Unit and the Sysmac Studio version, the following restrictions apply:

- For NX701 and NJ101 CPU Units, the instruction can be used with Sysmac Studio version 1.13 or higher.
- For an NX1P2 CPU Unit, the instruction can be used with Sysmac Studio version 1.17 or higher.
- For an NJ301 CPU Unit, the instruction can be used with the unit version 1.10 or later and Sysmac Studio version 1.12 or higher.
- For an NY-series Controller, the instruction can be used with Sysmac Studio version 1.17 or higher.

Sample Programming

This sample transfers EtherCAT communications packets to an SD Memory Card when an EtherCAT slave error occurs. The file name is 'PacketFile.' The processing procedure is as follows:

- 1** The system-defined variable `_EC_ErrSta` (EtherCAT Error) is monitored and processing is started if an error occurs.
- 2** The `EC_StopMon` instruction is used to stop execution of packet monitoring for EtherCAT communications.
- 3** The `EC_SaveMon` instruction is used to save EtherCAT communications packet data to an internal file in the main memory of the CPU Unit.
- 4** The `EC_CopyMon` instruction is used to copy that file to the SD Memory Card.
- 5** The `EC_StartMon` instruction is used to restart execution of packet monitoring for EtherCAT communications.

LD

Internal Variables	Variable	Data type	Initial value	Comment
	OperatingEnd	BOOL	FALSE	Processing completed
	Operating	BOOL	FALSE	Execution condition
	RS_instance	RS		
	EC_StopMon_instance	EC_StopMon		
	EC_SaveMon_instance	EC_SaveMon		
	EC_CopyMon_instance	EC_CopyMon		
	EC_StartMon_instance	EC_StartMon		

External Variables	Variable	Data type	Constant	Comment
	_EC_ErrSta	WORD	✓	Built-in EtherCAT Error
	_EC_PktMonStop	BOOL	✓	Packet Monitoring Stopped
	_EC_PktSaving	BOOL	✓	Saving Packet Data File
	_Card1Ready	BOOL	✓	SD Memory Card Ready Flag

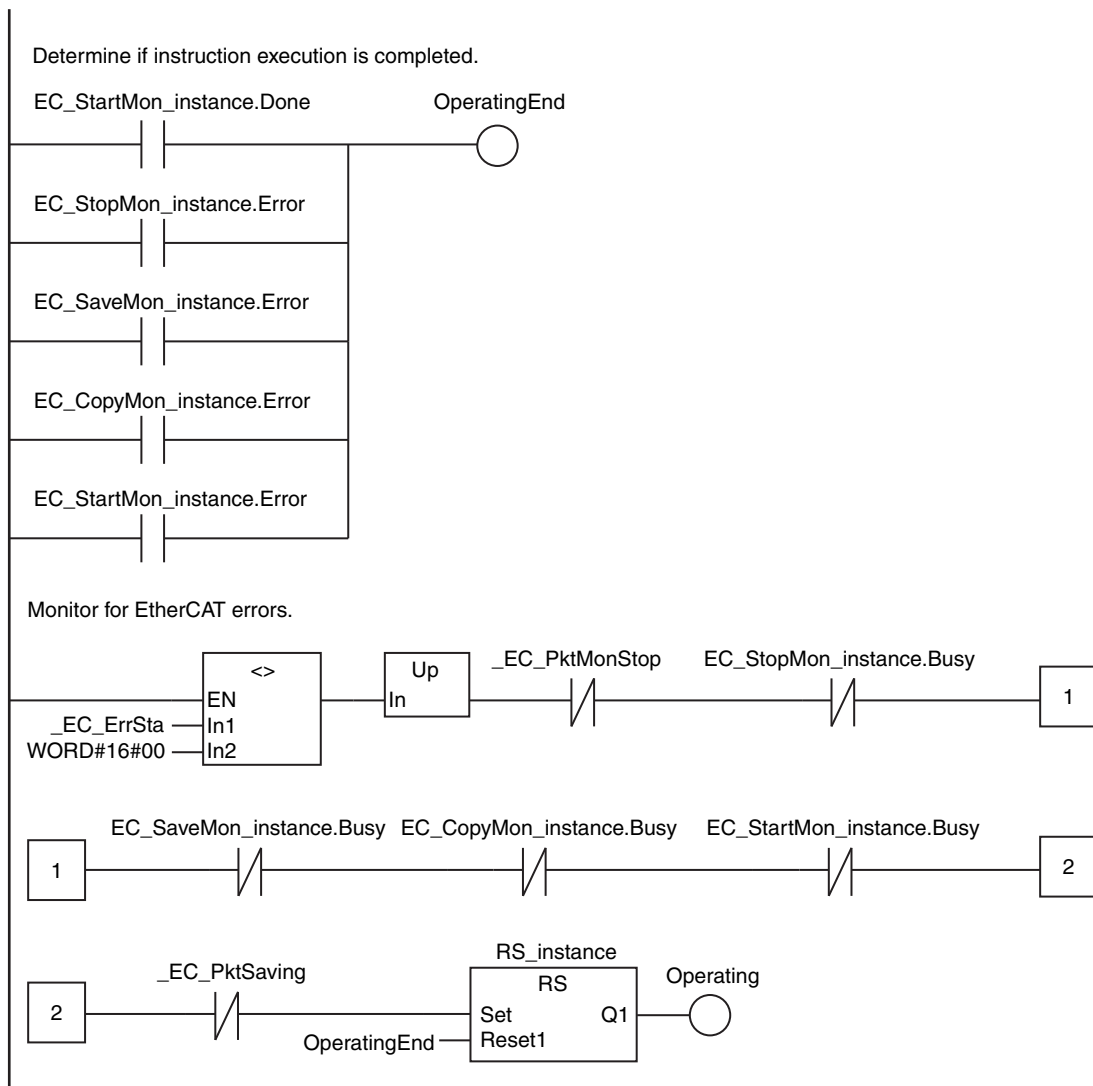

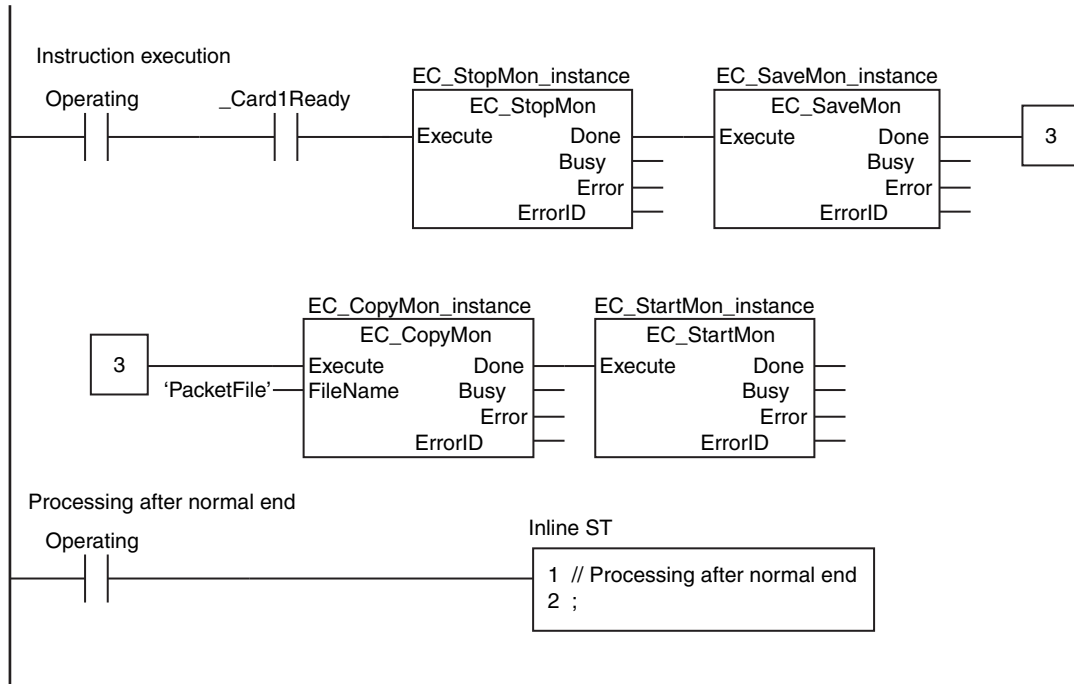

ST

Internal Variables	Variable	Data type	Initial value	Comment
	EC_Err	BOOL	FALSE	Controller error in the EtherCAT Master Function Module.
	EC_Err_Trigger	BOOL	FALSE	Detect when <i>EC_Err</i> changes to TRUE.
	DoEC_PktSave	BOOL	FALSE	Processing
	Stage	INT	0	Stage change
	R_TRIG_instance	R_TRIG		
	EC_StopMon_instance	EC_StopMon		
	EC_SaveMon_instance	EC_SaveMon		
	EC_CopyMon_instance	EC_CopyMon		
	EC_StartMon_instance	EC_StartMon		

External Variables	Variable	Data type	Constant	Comment
	_EC_ErrSta	WORD	✓	Built-in EtherCAT Error
	_EC_PktMonStop	BOOL	✓	Packet Monitoring Stopped
	_EC_PktSaving	BOOL	✓	Saving Packet Data File
	_Card1Ready	BOOL	✓	SD Memory Card Ready Flag

```
// Start sequence when _EC_ErrSta changes to TRUE.
EC_Err := (_EC_ErrSta <> WORD#16#00);
R_TRIG_instance(Clk:=EC_Err, Q=>EC_Err_Trigger);

IF ( (EC_Err_Trigger=TRUE) AND (DoEC_PktSave=FALSE) AND (_EC_PktMonStop=FALSE)
AND (_EC_PktSaving=FALSE) AND (_Card1Ready=TRUE) ) THEN
  DoEC_PktSave:=TRUE;
  Stage :=INT#1;
  EC_StopMon_instance(Execute:=FALSE); // Initialize instance.
  EC_SaveMon_instance(Execute:=FALSE);
  EC_CopyMon_instance(Execute:=FALSE);
  EC_StartMon_instance(Execute:=FALSE);
END_IF;

// Instruction execution
IF (DoEC_PktSave=TRUE) THEN
  CASE Stage OF
    1 : // Stop EtherCAT packet monitor.
      EC_StopMon_instance(
        Execute :=TRUE);

      IF (EC_StopMon_instance.Done=TRUE) THEN
        Stage:=INT#2; // Normal end
      ELSIF (EC_StopMon_instance.Error=TRUE) THEN
        Stage:=INT#10; // Error end
      END_IF;

    2 : // Save EtherCAT packet data in an internal file.
      EC_SaveMon_instance(
        Execute :=TRUE);

      IF (EC_SaveMon_instance.Done=TRUE) THEN
        Stage:=INT#3; // Normal end
      ELSIF (EC_SaveMon_instance.Error=TRUE) THEN
        Stage:=INT#20; // Error end
      END_IF;
  END_CASE;
END_IF;
```

```
3 : // Copy EtherCAT packet data file to the SD Memory Card.
    EC_CopyMon_instance(
        Execute :=TRUE,
        FileName :='PacketFile');

    IF (EC_CopyMon_instance.Done=TRUE) THEN
        Stage:=INT#4; // Normal end
    ELSIF (EC_CopyMon_instance.Error=TRUE) THEN
        Stage:=INT#30; // Error end
    END_IF;

4 : // Restart EtherCAT packet monitor.
    EC_StartMon_instance(
        Execute :=TRUE);

    IF (EC_StartMon_instance.Done=TRUE) THEN
        Stage:=INT#0; // Normal end
    ELSIF (EC_StartMon_instance.Error=TRUE) THEN
        Stage:=INT#40; // Error end
    END_IF;

0 : // Processing after normal end
    DoEC_PktSave:=FALSE;

    ELSE // Processing after error end
        DoEC_PktSave:=FALSE;
    END_CASE;
END_IF;
```

EC_StopMon

The EC_StopMon instruction stops execution of packet monitoring for EtherCAT communications.

Instruction	Name	FB/ FUN	Graphic expression	ST expression
EC_StopMon	Stop EtherCAT Packet Monitor	FB		EC_StopMon_instance(Execute, Done, Busy, Error, ErrorID);

Variables

Only common variables are used.

Function

The EC_StopMon instruction stops execution of packet monitoring for EtherCAT communications. The packet monitor function collects a specified number of the most recent EtherCAT communications packets.

Related System-defined Variables

Name	Meaning	Data type	Description
_EC_PktMonStop	Packet Monitoring Stopped	BOOL	This variable shows if packet monitoring is stopped. TRUE: Stopped. FALSE: Not stopped.
_EC_PktSaving	Saving Packet Data File	BOOL	This variable shows if the instruction is saving packet data in an internal file in the main memory of the CPU Unit. TRUE: Saving. FALSE: Not saving.

Additional Information

- Do the following to save collected packet data in an internal file in the main memory of the CPU Unit: First, stop packet monitoring. Then execute the EC_SaveMon instruction to save the packets.
- Refer to the *NJ/NX-series CPU Unit Built-in EtherCAT Port User's Manual* (Cat. No. W505) or *NY-series Industrial Panel PC / Industrial Box PC Built-in EtherCAT Port User's Manual* (Cat. No. W562) for details on EtherCAT communications.

Precautions for Correct Use

- Execution of this instruction is continued until processing is completed even if the value of *Execute* changes to FALSE or the execution time exceeds the task period. The value of *Done* changes to TRUE when processing is completed. Use this to confirm normal completion of processing.
- Refer to *Using this Section* on page 2-3 for a timing chart for *Execute*, *Done*, *Busy*, and *Error*.

- This instruction can be used only for the NJ/NX-series and NY-series Controller EtherCAT ports.
- You can execute a maximum of 32 of the following instructions at the same time: EC_CoESDOWrite, EC_CoESDORead, EC_StartMon, EC_StopMon, EC_SaveMon, EC_CopyMon, EC_DisconnectSlave, EC_ConnectSlave, EC_ChangeEnableSetting, IOL_ReadObj, and IOL_WriteObj.
- An error occurs in the following case. *Error* will change to TRUE.
 - Packet monitoring is already stopped.
 - More than 32 of the following instructions were executed at the same time: EC_CoESDOWrite, EC_CoESDORead, EC_StartMon, EC_StopMon, EC_SaveMon, EC_CopyMon, EC_DisconnectSlave, EC_ConnectSlave, EC_ChangeEnableSetting, IOL_ReadObj and IOL_WriteObj.



Version Information

Depending on the unit version of the CPU Unit and the Sysmac Studio version, the following restrictions apply:

- For NX701 and NJ101 CPU Units, the instruction can be used with Sysmac Studio version 1.13 or higher.
- For an NX1P2 CPU Unit, the instruction can be used with Sysmac Studio version 1.17 or higher.
- For an NJ301 CPU Unit, the instruction can be used with the unit version 1.10 or later and Sysmac Studio version 1.12 or higher.
- For an NY-series Controller, the instruction can be used with Sysmac Studio version 1.17 or higher.

Sample Programming

Refer to the sample programming that is provided for the EC_StartMon instruction (page 2-934).

EC_SaveMon

The EC_SaveMon instruction saves EtherCAT communications packet data to an internal file in the main memory of the CPU Unit.

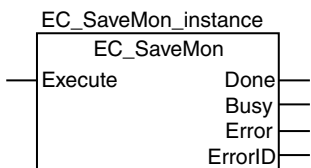
Instruction	Name	FB/ FUN	Graphic expression	ST expression
EC_SaveMon	Save EtherCAT Packets	FB		EC_SaveMon_instance(Execute, Done, Busy, Error, ErrorID);

Variables

Only common variables are used.

Function

The EC_SaveMon instruction saves EtherCAT communications packet data that was collected by the packet monitoring function to an internal file in the main memory of the CPU Unit. The packet monitor function collects a specified number of the most recent EtherCAT communications packets.

Related System-defined Variables

Name	Meaning	Data type	Description
_EC_PktMonStop	Packet Monitoring Stopped	BOOL	This variable shows if packet monitoring is stopped. TRUE: Stopped. FALSE: Not stopped.
_EC_PktSaving	Saving Packet Data File	BOOL	This variable shows if the instruction is saving packet data in an internal file in the main memory of the CPU Unit. TRUE: Saving. FALSE: Not saving.

Additional Information

- You cannot execute packet monitoring while this instruction is in execution.
- Refer to the *NJ/NX-series CPU Unit Built-in EtherCAT Port User's Manual* (Cat. No. W505) or *NY-series Industrial Panel PC / Industrial Box PC Built-in EtherCAT Port User's Manual* (Cat. No. W562) for details on EtherCAT communications.

Precautions for Correct Use

- Execution of this instruction is continued until processing is completed even if the value of *Execute* changes to FALSE or the execution time exceeds the task period. The value of *Done* changes to TRUE when processing is completed. Use this to confirm normal completion of processing.
- Refer to *Using this Section* on page 2-3 for a timing chart for *Execute*, *Done*, *Busy*, and *Error*.

- This instruction can be used only for the NJ/NX-series and NY-series Controller EtherCAT ports.
- You cannot execute this instruction while packet monitoring is in progress. Execute the EC_StopMon instruction in advance to stop packet monitoring.
- You can execute a maximum of 32 of the following instructions at the same time: EC_CoESDOWrite, EC_CoESDORead, EC_StartMon, EC_StopMon, EC_SaveMon, EC_CopyMon, EC_DisconnectSlave, EC_ConnectSlave, EC_ChangeEnableSetting, IOL_ReadObj, and IOL_WriteObj.
- An error occurs in the following case. *Error* will change to TRUE.
 - Packet monitoring is in progress.
 - More than 32 of the following instructions were executed at the same time: EC_CoESDOWrite, EC_CoESDORead, EC_StartMon, EC_StopMon, EC_SaveMon, EC_CopyMon, EC_DisconnectSlave, EC_ConnectSlave, EC_ChangeEnableSetting, IOL_ReadObj and IOL_WriteObj.

Version Information

Depending on the unit version of the CPU Unit and the Sysmac Studio version, the following restrictions apply:

- For NX701 and NJ101 CPU Units, the instruction can be used with Sysmac Studio version 1.13 or higher.
- For an NX1P2 CPU Unit, the instruction can be used with Sysmac Studio version 1.17 or higher.
- For an NJ301 CPU Unit, the instruction can be used with the unit version 1.10 or later and Sysmac Studio version 1.12 or higher.
- For an NY-series Controller, the instruction can be used with Sysmac Studio version 1.17 or higher.

Sample Programming

Refer to the sample programming that is provided for the EC_StartMon instruction (page 2-934).

EC_CopyMon

The EC_CopyMon instruction transfers packet data in an internal file in the main memory of the CPU Unit to a SD Memory Card.

Instruction	Name	FB/ FUN	Graphic expression	ST expression
EC_CopyMon	Transfer EtherCAT Packets	FB	<pre> graph LR subgraph EC_CopyMon_instance EC_CopyMon end Execute --> EC_CopyMon FileName --> EC_CopyMon EC_CopyMon --> Done EC_CopyMon --> Busy EC_CopyMon --> Error EC_CopyMon --> ErrorID </pre>	EC_CopyMon_instance(Execute, FileName, Done, Busy, Error, ErrorID);

Variables

Name	Meaning	I/O	Description	Valid range	Unit	Default
FileName	File name	Input	File name on the SD Memory Card	Depends on data type.	---	---

	Boolean	Bit strings					Integers							Real numbers	Times, durations, dates, and text strings					
	BOOL	BYTE	WORD	DWORD	LWORD	USINT	UINT	UDINT	ULINT	SINT	INT	DINT	LINT	REAL	LREAL	TIME	DATE	TOD	DT	STRING
FileName																				OK

Function

The EC_CopyMon instruction transfers packet data in an internal file in the main memory of the CPU Unit to a SD Memory Card. *FileName* specifies the file name on the SD Memory Card.

Related System-defined Variables

Name	Meaning	Data type	Description
_EC_PktSaving	Saving Packet Data File	BOOL	This variable shows if the instruction is saving packet data in an internal file in the main memory of the CPU Unit. TRUE: Saving. FALSE: Not saving.

Additional Information

Refer to the *NJ/NX-series CPU Unit Built-in EtherCAT Port User's Manual* (Cat. No. W505) or *NY-series Industrial Panel PC / Industrial Box PC Built-in EtherCAT Port User's Manual* (Cat. No. W562) for details on EtherCAT communications.

Precautions for Correct Use

- Execution of this instruction is continued until processing is completed even if the value of *Execute* changes to FALSE or the execution time exceeds the task period. The value of *Done* changes to TRUE when processing is completed. Use this to confirm normal completion of processing.
- Refer to *Using this Section* on page 2-3 for a timing chart for *Execute*, *Done*, *Busy*, and *Error*.
- This instruction can be used only for the NJ/NX-series and NY-series Controller EtherCAT ports.
- You cannot execute this instruction while a packet save operation is in progress.
- To use this instruction, execute the EC_SaveMon instruction in advance to save the packet data in an internal file in the main memory of the CPU Unit.
- You can execute a maximum of 32 of the following instructions at the same time: EC_CoESDOWrite, EC_CoESDORead, EC_StartMon, EC_StopMon, EC_SaveMon, EC_CopyMon, EC_DisconnectSlave, EC_ConnectSlave, EC_ChangeEnableSetting, IOL_ReadObj, and IOL_WriteObj.
- An error occurs in the following case. *Error* will change to TRUE.
 - A packet data file save operation is in progress.
 - More than 32 of the following instructions were executed at the same time: EC_CoESDOWrite, EC_CoESDORead, EC_StartMon, EC_StopMon, EC_SaveMon, EC_CopyMon, EC_DisconnectSlave, EC_ConnectSlave, EC_ChangeEnableSetting, IOL_ReadObj and IOL_WriteObj.



Version Information

Depending on the unit version of the CPU Unit and the Sysmac Studio version, the following restrictions apply:

- For NX701 and NJ101 CPU Units, the instruction can be used with Sysmac Studio version 1.13 or higher.
- For an NX1P2 CPU Unit, the instruction can be used with Sysmac Studio version 1.17 or higher.
- For an NJ301 CPU Unit, the instruction can be used with the unit version 1.10 or later and Sysmac Studio version 1.12 or higher.
- For an NY-series Controller, the instruction can be used with Sysmac Studio version 1.17 or higher.

Sample Programming

Refer to the sample programming that is provided for the EC_StartMon instruction (page 2-934).

EC_DisconnectSlave

The EC_DisconnectSlave instruction disconnects the specified slave from the network.

Instruction	Name	FB/ FUN	Graphic expression	ST expression
EC_DisconnectSlave	Disconnect EtherCAT Slave	FB		EC_DisconnectSlave_instance(Execute, NodeAdr, Done, Busy, Error, ErrorID);

Variables

Name	Meaning	I/O	Description	Valid range	Unit	Default
NodeAdr	Slave node address	Input	Node address of the slave to disconnect	1 to 512*	---	---

* The range is 1 to 192 for an NJ-series CPU Unit.

	Boolean	Bit strings					Integers							Real numbers	Times, durations, dates, and text strings					
	BOOL	BYTE	WORD	DWORD	LWORD	USINT	UINT	UDINT	ULINT	SINT	INT	DINT	LINT	REAL	LREAL	TIME	DATE	TOD	DT	STRING
NodeAdr							OK													

Function

The EC_DisconnectSlave instruction disconnects the slave specified with slave node address *NodeAdr* from the EtherCAT network.

Here, disconnection from the network means that the slave is placed in a state in which it does not operate even though it still exists on the network.

Related System-defined Variables

Name	Meaning	Data type	Description
_EC_EntrySlavTbl[i] “i” is the node address.	Network Connected Slave Table	BOOL[]	This variable shows if slaves are part of (i.e., exist on) the network. TRUE: Part of the network. FALSE: Not part of the network.
_EC_DisconnSlavTbl[i] “i” is the node address.	Disconnected Slave Table	BOOL[]	This variable shows the slaves for which there are currently disconnect commands in effect. TRUE: Disconnect command is in effect. FALSE: Disconnect command is not in effect.
_EC_DisableSlavTbl[i] “i” is the node address.	Disabled Slave Table	BOOL[]	This variable shows if slaves are disabled on the network. TRUE: Disabled. FALSE: Not disabled.

Additional Information

Refer to the *NJ/NX-series CPU Unit Built-in EtherCAT Port User's Manual* (Cat. No. W505) or *NY-series Industrial Panel PC / Industrial Box PC Built-in EtherCAT Port User's Manual* (Cat. No. W562) for details on EtherCAT communications.

Precautions for Correct Use

- Execution of this instruction is continued until processing is completed even if the value of *Execute* changes to FALSE or the execution time exceeds the task period. The value of *Done* changes to TRUE when processing is completed. Use this to confirm normal completion of processing.
- Refer to *Using this Section* on page 2-3 for a timing chart for *Execute*, *Done*, *Busy*, and *Error*.
- This instruction can be used only for the NJ/NX-series and NY-series Controller EtherCAT ports.
- If there are slaves with daisy-chain connections (i.e., connected to the output port) after the disconnected slave, they are disconnected from the EtherCAT network also.
- You cannot execute this instruction during execution of the following instructions: EC_DisconnectSlave, EC_ConnectSlave, EC_ChangeEnableSetting, ResetECError, RestartNXUnit, and NX_ChangeWriteMode.
- You can execute a maximum of 32 of the following instructions at the same time: EC_CoESDOWrite, EC_CoESDORead, EC_StartMon, EC_StopMon, EC_SaveMon, EC_CopyMon, EC_DisconnectSlave, EC_ConnectSlave, EC_ChangeEnableSetting, IOL_ReadObj, and IOL_WriteObj.
- An error occurs in the following case. *Error* will change to TRUE.
 - The slave specified with *NodeAdr* is not part of the EtherCAT network. That is, the value of *_EC_EntrySlavTb[i]* (Network Connected Slave Table) is FALSE.
 - The slave specified with *NodeAdr* is disabled.
 - The EC_DisconnectSlave, EC_ConnectSlave, EC_ChangeEnableSetting, ResetECError, RestartNXUnit, or NX_ChangeWriteMode instruction is already in execution.
 - More than 32 of the following instructions were executed at the same time: EC_CoESDOWrite, EC_CoESDORead, EC_StartMon, EC_StopMon, EC_SaveMon, EC_CopyMon, EC_DisconnectSlave, EC_ConnectSlave, EC_ChangeEnableSetting, IOL_ReadObj and IOL_WriteObj.

Sample Programming

This sample disconnects slave 1 from the EtherCAT network and then connects it again. When *Trigger1* changes to TRUE, the EC_DisconnectSlave instruction is executed to disconnect slave 1. When *Trigger2* changes to TRUE, the EC_ConnectSlave instruction is executed to connect slave 1 again.

Exclusive Control of Instructions

You cannot execute the EC_DisconnectSlave and EC_ConnectSlave instructions at the same time. Both of these instructions are executed over more than one task. Confirm the completion of the instruction that was executed first before you execute the other instruction. The *ExclusiveFlg* variable (Instruction Exclusive Flag) is used for this purpose. If the value of *ExclusiveFlg* is TRUE, then one of the instructions is in execution. Do not execute the next instruction while the value of *ExclusiveFlg* is TRUE.

You cannot execute the EC_DisconnectSlave and EC_ConnectSlave instructions at the same time even in separate tasks. Therefore, *ExclusiveFlg* is defined as a global variable in this sample programming. That allows this sample programming to perform exclusive control with instructions in other tasks. The same global variable, *ExclusiveFlg*, must also be used in the other tasks to perform exclusive control of the instructions.

You cannot execute the EC_ChangeEnableSetting instruction at the same time as the EC_DisconnectSlave or EC_ConnectSlave instruction. The sample programming that is provided for the EC_ChangeEnableSetting instruction on page 2-955 uses the same *ExclusiveFlg* global variable as in this sample programming as an example of exclusive control of instructions.

Definitions of Global Variables

Global Variables

Variable	Data type	Initial value	Comment
ExclusiveFlg	BOOL	FALSE	Instruction Exclusive Flag

LD

Internal Variables	Variable	Data type	Initial value	Comment
	Operating1End	BOOL	FALSE	Processing 1 completed.
	Trigger1	BOOL	FALSE	Execution condition 1
	Operating1	BOOL	FALSE	Processing 1
	RS_instance1	RS		
	EC_DisconnectSlave_instance	EC_DisconnectSlave		
	Operating2End	BOOL	FALSE	Processing 2 completed.
	Trigger2	BOOL	FALSE	Execution condition 2
	Operating2	BOOL	FALSE	Processing 2
	RS_instance2	RS		
	EC_ConnectSlave_instance	EC_ConnectSlave		

External Variables	Variable	Data type	Constant	Comment
	_EC_EntrySlavTbl	ARRAY[1..512] OF BOOL *1	✓	Network Connected Slave Table
	_EC_DisconnSlavTbl	ARRAY[1..512] OF BOOL *1	✓	Disconnected Slave Table
	ExclusiveFlg	BOOL	---	Instruction Exclusive Flag

*1 The data type is ARRAY [1..192] OF BOOL for an NJ-series CPU Unit.

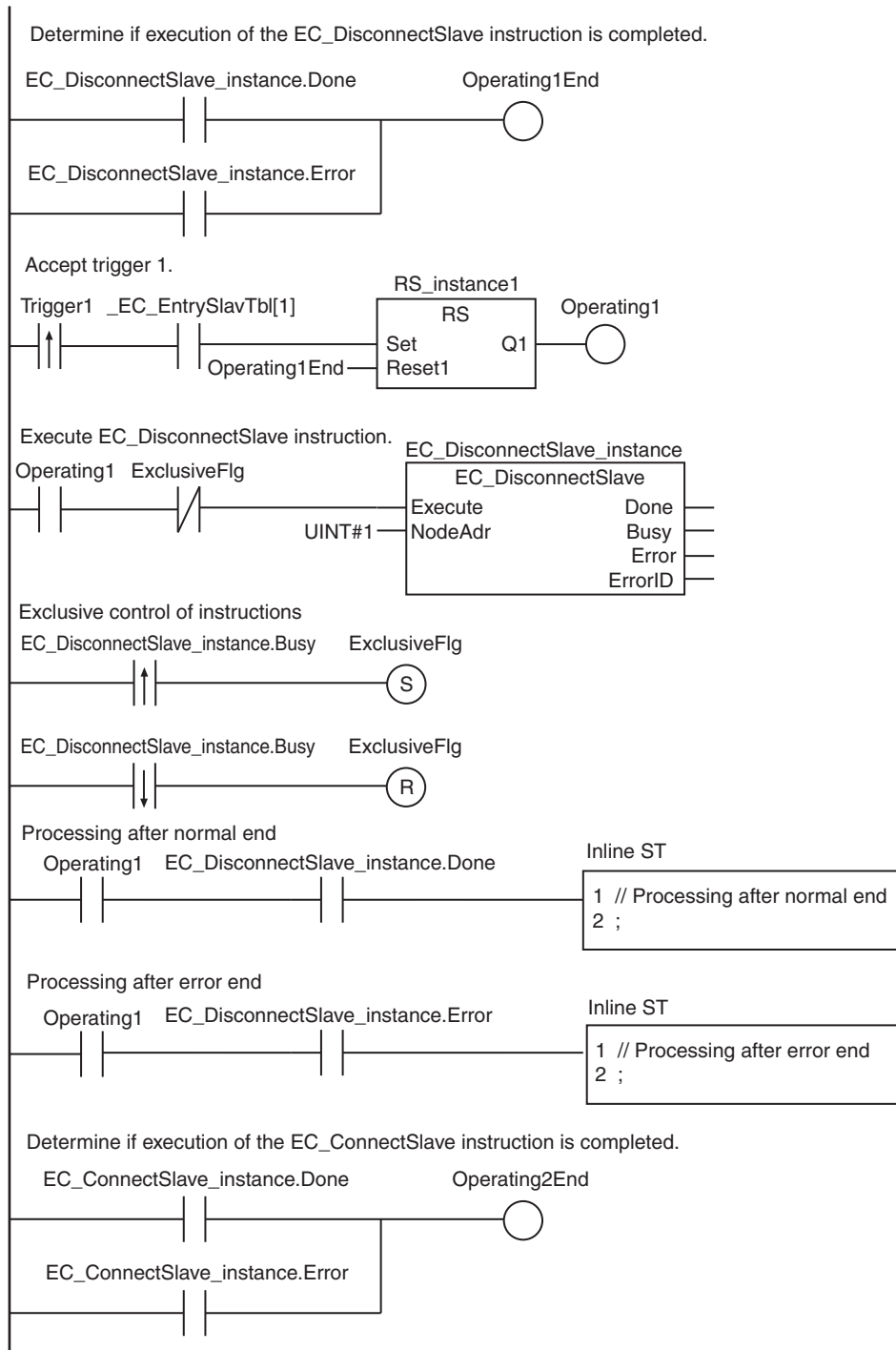

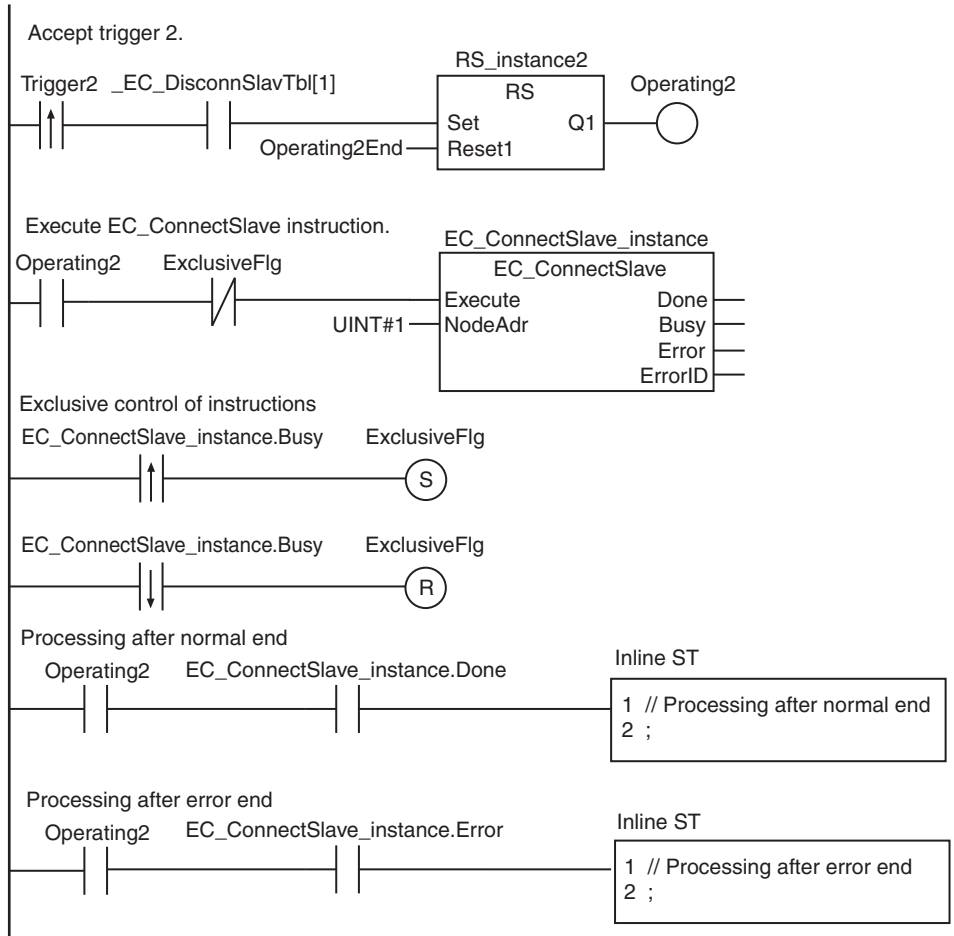

ST

Internal Variables	Variable	Data type	Initial value	Comment
	Trigger1	BOOL	FALSE	Execution condition 1
	LastTrigger1	BOOL	FALSE	Value of <i>Trigger1</i> from previous task period
	Operating1Start	BOOL	FALSE	Processing 1 started.
	Operating1	BOOL	FALSE	Processing 1
	DisconnectSet	BOOL	FALSE	EC_DisconnectSlave instruction execution is in progress.
	DisconnectReset	BOOL	FALSE	EC_DisconnectSlave instruction execution is not in progress.
	EC_DisconnectSlave_instance	EC_DisconnectSlave		
	Trigger2	BOOL	FALSE	Execution condition 2
	LastTrigger2	BOOL	FALSE	Value of <i>Trigger2</i> from previous task period
	Operating2Start	BOOL	FALSE	Processing 2 started.
	Operating2	BOOL	FALSE	Processing 2
	ConnectSet	BOOL	FALSE	EC_ConnectSlave instruction execution is in progress.
	ConnectReset	BOOL	FALSE	EC_ConnectSlave instruction execution is not in progress.
	EC_ConnectSlave_instance	EC_ConnectSlave		
	R_TRIG_instance1	R_TRIG		
	F_TRIG_instance1	F_TRIG		
	RS_instance1	RS		
	R_TRIG_instance2	R_TRIG		
	F_TRIG_instance2	F_TRIG		
	RS_instance2	RS		

External Variables	Variable	Data type	Constant	Comment
	_EC_EntrySlavTbl	ARRAY[1..512] OF BOOL *1	✓	Network Connected Slave Table
	_EC_DisconnSlavTbl	ARRAY[1..512] OF BOOL *1	✓	Disconnected Slave Table
	ExclusiveFlg	BOOL	---	Instruction Exclusive Flag

*1 The data type is ARRAY [1..192] OF BOOL for an NJ-series CPU Unit.

```
// Detect when Trigger1 changes to TRUE.
IF ( (Trigger1=TRUE) AND (LastTrigger1=FALSE) AND (_EC_EntrySlavTbl[1]=TRUE) ) THEN
    Operating1Start:=TRUE;
    Operating1      :=TRUE;
END_IF;
LastTrigger1:=Trigger1;

// Initialize EC_DisconnectSlave instruction.
IF (Operating1Start=TRUE) THEN
    EC_DisconnectSlave_instance(Execute:=FALSE);
    Operating1Start:=FALSE;
END_IF;

// Execute EC_DisconnectSlave instruction.
IF (Operating1=TRUE) THEN
```

```

EC_DisconnectSlave_instance(
    Execute:=NOT(ExclusiveFlg),
    NodeAdr:=UINT#1);

// Exclusive control of instructions
R_TRIG_instance1(EC_DisconnectSlave_instance.Busy, DisconnectSet);
F_TRIG_instance1(EC_DisconnectSlave_instance.Busy, DisconnectReset);
RS_instance1(DisconnectSet, DisconnectReset, ExclusiveFlg);

IF (EC_DisconnectSlave_instance.Done=TRUE) THEN
    // Processing after normal end
    Operating1:=FALSE;
END_IF;

IF (EC_DisconnectSlave_instance.Error=TRUE) THEN
    // Processing after error end
    Operating1:=FALSE;
END_IF;
END_IF;

// Detect when Trigger2 changes to TRUE.
IF ( (Trigger2=TRUE) AND (LastTrigger2=FALSE) AND ( _EC_DisconnSlavTbl[1]=TRUE) ) THEN
    Operating2Start:=TRUE;
    Operating2      :=TRUE;
END_IF;
LastTrigger2:=Trigger2;

// Initialize EC_ConnectSlave instruction.
IF (Operating2Start=TRUE) THEN
    EC_ConnectSlave_instance(Execute:=FALSE);
    Operating2Start:=FALSE;
END_IF;

// Execute EC_ConnectSlave instruction.
IF (Operating2=TRUE) THEN
    EC_ConnectSlave_instance(
        Execute:=NOT(ExclusiveFlg),
        NodeAdr:=UINT#1);

    // Exclusive control of instructions
    R_TRIG_instance2(EC_ConnectSlave_instance.Busy, ConnectSet);
    F_TRIG_instance2(EC_ConnectSlave_instance.Busy, ConnectReset);
    RS_instance2(ConnectSet, ConnectReset, ExclusiveFlg);

    IF (EC_ConnectSlave_instance.Done=TRUE) THEN
        // Processing after normal end
        Operating2:=FALSE;
    END_IF;

    IF (EC_ConnectSlave_instance.Error=TRUE) THEN
        // Processing after error end
        Operating2:=FALSE;
    END_IF;
END_IF;

```

EC_ConnectSlave

The EC_ConnectSlave instruction connects the specified slave to the EtherCAT network.

Instruction	Name	FB/ FUN	Graphic expression	ST expression
EC_ConnectSlave	Connect EtherCAT Slave	FB		EC_ConnectSlave_instance(Execute, NodeAdr, Done, Busy, Error, ErrorID);

Variables

Name	Meaning	I/O	Description	Valid range	Unit	Default
NodeAdr	Slave node address	Input	Node address of the slave to connect	0*1 to 512*2	---	---

*1 Here, 0 means all of the slaves that are registered in the network settings.

*2 The range is 1 to 192 for an NJ-series CPU Unit.

Version Information

For an NJ-series CPU Unit, the valid range of slave node addresses depends on the version as follows:

- Version 1.10 or later: 0 to 192
- Version 1.09 or earlier: 1 to 192

	Boolean	Bit strings				Integers							Real numbers		Times, durations, dates, and text strings					
	BOOL	BYTE	WORD	DWORD	LWORD	USINT	UINT	UDINT	ULINT	SINT	INT	DINT	LINT	REAL	LREAL	TIME	DATE	TOD	DT	STRING
NodeAdr							OK													

Function

The EC_ConnectSlave instruction connects the slave specified with slave node address *NodeAdr* to the EtherCAT network.

Here, connection to the network means that the slave exists on the network and it is placed in a state in which it operates.

Related System-defined Variables

Name	Meaning	Data type	Description
<code>_EC_EntrySlavTbl[i]</code> “i” is the node address.	Network Connected Slave Table	BOOL[]	This variable shows if slaves are part of (i.e., exist on) the network. TRUE: Part of the network. FALSE: Not part of the network.
<code>_EC_DisconnSlavTbl[i]</code> “i” is the node address.	Disconnected Slave Table	BOOL[]	This variable shows the slaves for which there are currently disconnect commands in effect. TRUE: Disconnect command is in effect. FALSE: Disconnect command is not in effect.

Additional Information

Refer to the *NJ/NX-series CPU Unit Built-in EtherCAT Port User's Manual* (Cat. No. W505) or *NY-series Industrial Panel PC / Industrial Box PC Built-in EtherCAT Port User's Manual* (Cat. No. W562) for details on EtherCAT communications.

Precautions for Correct Use

- Execution of this instruction is continued until processing is completed even if the value of *Execute* changes to FALSE or the execution time exceeds the task period. The value of *Done* changes to TRUE when processing is completed. Use this to confirm normal completion of processing.
- Refer to *Using this Section* on page 2-3 for a timing chart for *Execute*, *Done*, *Busy*, and *Error*.
- This instruction can be used only for the NJ/NX-series and NY-series Controller EtherCAT ports.
- You cannot execute this instruction during execution of the following instructions: *EC_DisconnectSlave*, *EC_ConnectSlave*, *EC_ChangeEnableSetting*, *ResetECError*, *RestartNXUnit*, and *NX_ChangeWriteMode*.
- You can execute a maximum of 32 of the following instructions at the same time: *EC_CoESDOWrite*, *EC_CoESDORed*, *EC_StartMon*, *EC_StopMon*, *EC_SaveMon*, *EC_CopyMon*, *EC_DisconnectSlave*, *EC_ConnectSlave*, *EC_ChangeEnableSetting*, *IOL_ReadObj*, and *IOL_WriteObj*.
- An error occurs in the following cases. *Error* will change to TRUE.
 - The slave specified with *NodeAdr* is not part of the EtherCAT network. That is, the value of `_EC_EntrySlavTbl[i]` (Network Connected Slave Table) is FALSE.
 - The *EC_DisconnectSlave*, *EC_ConnectSlave*, *EC_ChangeEnableSetting*, *ResetECError*, *RestartNXUnit*, or *NX_ChangeWriteMode* instruction is already in execution.
 - More than 32 of the following instructions were executed at the same time: *EC_CoESDOWrite*, *EC_CoESDORed*, *EC_StartMon*, *EC_StopMon*, *EC_SaveMon*, *EC_CopyMon*, *EC_DisconnectSlave*, *EC_ConnectSlave*, *EC_ChangeEnableSetting*, *IOL_ReadObj* and *IOL_WriteObj*.

Sample Programming

Refer to the sample programming that is provided for the *EC_DisconnectSlave* instruction (page 2-946).

EC_ChangeEnableSetting

The EC_ChangeEnableSetting instruction enables or disables an EtherCAT slave.

Instruction	Name	FB/ FUN	Graphic expression	ST expression
EC_ChangeEnableSetting	Enable/Disable EtherCAT Slave	FB		EC_ChangeEnableSetting_instance(Execute, NodeAdr, IsEnable, Done, Busy, Error, ErrorID);

Variables

Name	Meaning	I/O	Description	Valid range	Unit	Default
NodeAdr	Slave node address	Input	Node address of the EtherCAT slave to enable or disable	1 to 512*	---	1
IsEnable	Enable/disable designation		Designation of whether to enable or disable the specified EtherCAT slave TRUE: Enable FALSE: Disable	Depends on data type.		TRUE

* The range is 1 to 192 for an NJ-series CPU Unit.

	Boolean	Bit strings				Integers						Real numbers		Times, durations, dates, and text strings						
	BOOL	BYTE	WORD	DWORD	LWORD	USINT	UINT	UDINT	ULINT	SINT	INT	DINT	LINT	REAL	LREAL	TIME	DATE	TOD	DT	STRING
NodeAdr							OK													
IsEnable	OK																			

Function

The EC_ChangeEnableSetting instruction enables or disables the EtherCAT slave that is specified with slave node address *NodeAdr*. The slave is enabled if enable/disable designation *IsEnable* is TRUE and disabled if it is FALSE.

Enabling or disabling the slave is completed when the instruction is completed normally (i.e., when the value of *Done* changes to TRUE).

Whether the instruction is completed normally depends on the status of the specified EtherCAT slave, i.e., whether it is enabled or disabled, whether it is participating or not participating, and whether it exists in the EtherCAT network. The status after execution of the instruction is given in the following table according to the status of the EtherCAT slave before execution of the instruction.

Status before instruction execution			Value of <i>IsEnable</i>	Status after instruction execution	
Enabled/disabled	Participating/not participating	Exists*1		Normal/error end	Enabled/disabled
Enabled	Participating	Yes	TRUE	Normal end	Enabled
			FALSE		Disabled

Status before instruction execution			Value of <i>IsEnable</i>	Status after instruction execution	
Enabled/disabled	Participating/not participating	Exists*1		Normal/error end	Enabled/disabled
Enabled	Not participating	Yes	TRUE	Error end	Enabled (not changed)
			FALSE		
		No	TRUE		
			FALSE		
Disabled	---*2	Yes	TRUE	Normal end	Enabled
		FALSE	Disabled		
Disabled	---*2	No	TRUE	Error end	Disabled (not changed)
			FALSE		

*1 This indicates whether the specified EtherCAT slave is physically connected to the EtherCAT network.
 Yes: Physically connected. No: Not physically connected.

*2 There is no participating/not participating distinction for EtherCAT slaves that are disabled.

The following example shows how to enable the EtherCAT slave at node address 1. UINT#1 is specified for *NodeAdr* and TRUE is specified for *IsEnable*.

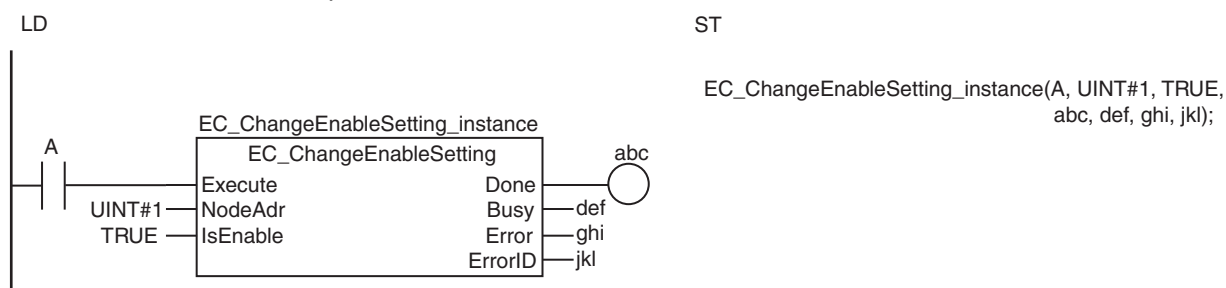

Related System-defined Variables

Name	Meaning	Data type	Description
<code>_EC_EntrySlavTbl [i]</code> "i" is the node address.	Network Connected Slave Table	BOOL[]	This variable shows if slaves are part of (i.e., exist on) the network. TRUE: Part of the network. FALSE: Not part of the network.
<code>_EC_DisconnSlavTbl[i]</code> "i" is the node address.	Disconnected Slave Table	BOOL[]	This variable shows the slaves for which there are currently disconnect commands in effect. TRUE: Disconnect command is in effect. FALSE: Disconnect command is not in effect.
<code>_EC_DisableSlavTbl[i]</code> "i" is the node address.	Disabled Slave Table	BOOL[]	This variable shows if slaves are disabled. TRUE: Disabled. FALSE: Not disabled or not part of the network.

Additional Information

- Refer to the *NJ/NX-series CPU Unit Built-in EtherCAT Port User's Manual* (Cat. No. W505) or *NY-series Industrial Panel PC / Industrial Box PC Built-in EtherCAT Port User's Manual* (Cat. No. W562) for details on EtherCAT communications.
- Use the `EC_ConnectSlave` instruction on page 2-953 to connect an EtherCAT slave to the EtherCAT network.

Precautions for Correct Use

- Execution of this instruction is continued until processing is completed even if the value of *Execute* changes to FALSE or the execution time exceeds the task period. The value of *Done* changes to TRUE when processing is completed. Use this to confirm normal completion of processing.
- Refer to *Using this Section* on page 2-3 for a timing chart for *Execute*, *Done*, *Busy*, and *Error*.
- This instruction can be used only for the NJ/NX-series and NY-series Controller EtherCAT ports.
- You cannot execute this instruction during execution of the following instructions: EC_DisconnectSlave, EC_ConnectSlave, EC_ChangeEnableSetting, ResetECError, RestartNXUnit, and NX_ChangeWriteMode.
- The execution results of this instruction are not saved in non-volatile memory in the CPU Unit. Therefore, if the power supply to the Controller is cycled after execution of this instruction or if the user program is downloaded, the enable/disable setting of the EtherCAT slave will return to the value that was set from the Sysmac Studio.
- You can execute a maximum of 32 of the following instructions at the same time: EC_CoESDOWrite, EC_CoESDORead, EC_StartMon, EC_StopMon, EC_SaveMon, EC_CopyMon, EC_DisconnectSlave, EC_ConnectSlave, EC_ChangeEnableSetting, IOL_ReadObj, and IOL_WriteObj.
- An error occurs in the following cases. *Error* will change to TRUE.
 - The slave specified with *NodeAdr* is not part of the EtherCAT network. That is, the value of *_EC_EntrySlavTbl[i]* (Network Connected Slave Table) is FALSE.
 - The value of *NodeAdr* is outside of the valid range.
 - The EC_DisconnectSlave, EC_ConnectSlave, EC_ChangeEnableSetting, ResetECError, RestartNXUnit, or NX_ChangeWriteMode instruction is already in execution.
 - More than 32 of the following instructions were executed at the same time: EC_CoESDOWrite, EC_CoESDORead, EC_StartMon, EC_StopMon, EC_SaveMon, EC_CopyMon, EC_DisconnectSlave, EC_ConnectSlave, EC_ChangeEnableSetting, IOL_ReadObj and IOL_WriteObj.



Version Information

A CPU Unit with unit version 1.04 or later and Sysmac Studio version 1.05 or higher are required to use this instruction.

Sample Programming

● Example of Disconnecting EtherCAT Slaves from the EtherCAT Network

Production line 1 in the following system is left running while EtherCAT slaves C, D, and E on production line 2 are removed. Motion control axes are already set for EtherCAT slaves C, D, and E. Therefore, the EtherCAT slaves are disabled and the axes are changed to unused axes.

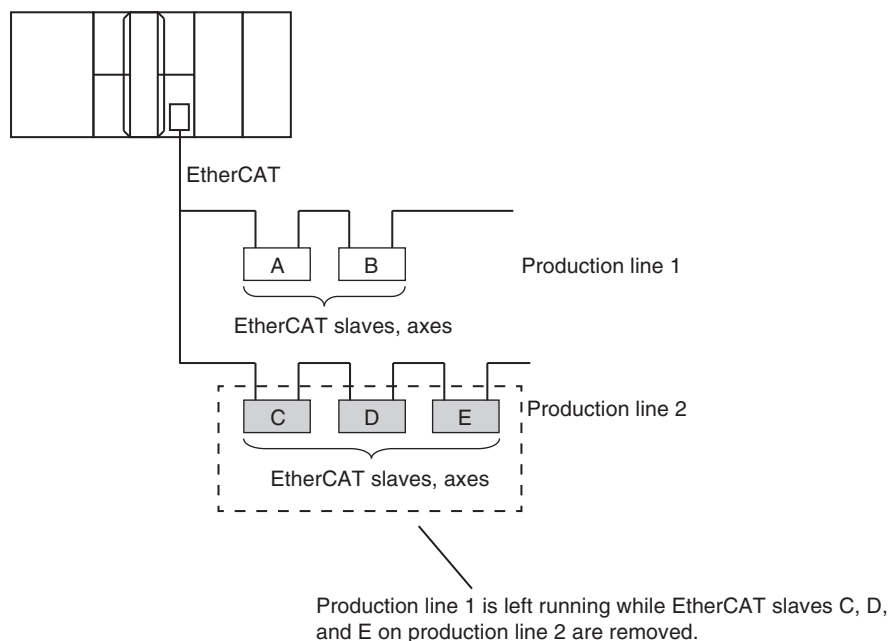

Procedure

The operating procedure for the sample programming is as follows:

- 1** The operator presses a button on an HMI to turn ON the execution condition.
- 2** The Controller disables EtherCAT slaves C, D, and E. Also, the axes for those slaves are changed to unused axes.
- 3** When disabling and changing the axes to unused axes is completed for all three slaves, the Controller lights a removal OK lamp.
- 4** After the operator confirms that the removal OK lamp is lit, the operator removes the three EtherCAT slaves.

Instruction to Change Axes to Unused Axes

The MC_ChangeAxisUse instruction is used to change the axes to unused axes. Refer to the *NJ/NX-series Motion Control Instructions Reference Manual* (Cat. No. W508) or *NY-series Motion Control Instructions Reference Manual* (Cat. No. W561) for the detailed specifications of the MC_ChangeAxisUse instruction.

Exclusive Control of Instructions

You can execute only one EC_ChangeEnableSetting instruction at the same time. Also, the EC_ChangeEnableSetting instruction is executed over more than one task. Confirm the completion of the EC_ChangeEnableSetting instruction before you execute the next EC_ChangeEnableSetting instruction. The *ExclusiveFlg* variable (Instruction Exclusive Flag) is used for this purpose. If the value of *ExclusiveFlg* is TRUE, then an EC_ChangeEnableSetting instruction is in execution. Do not execute the next EC_ChangeEnableSetting instruction while the value of *ExclusiveFlg* is TRUE.

You cannot execute the EC_ChangeEnableSetting instruction at the same time as another EC_ChangeEnableSetting instruction is in execution in another task. Therefore, *ExclusiveFlg* is defined as a global variable in this sample programming. That allows this sample programming to perform exclusive control with EC_ChangeEnableSetting instructions in the other tasks. The same global variable, *ExclusiveFlg*, must also be used in the other tasks to perform exclusive control of the instructions.

You cannot execute the EC_ChangeEnableSetting instruction at the same time as the EC_DisconnectSlave or EC_ConnectSlave instruction. The sample programming that is provided for the EC_DisconnectSlave instruction on page 2-946 uses the same *ExclusiveFlg* global variable as in this sample programming as an example of exclusive control of instructions.

Axis Variables and Node Addresses for the EtherCAT Slaves

The axis variables that are assigned to the axes for EtherCAT slaves C, D, and E and the node addresses of the slaves are given in the following table.

EtherCAT slaves	Axis variable	Node address
C	MC_Axis000	1
D	MC_Axis001	2
E	MC_Axis002	3

Definitions of Global Variables

Global Variables

Variable	Data type	Initial value	AT specification	Constant	Comment
MC_Axis000	_sAXIS_REF		MC://_MC_AX[0]	✓	Axis variable for EtherCAT slave C
MC_Axis001	_sAXIS_REF		MC://_MC_AX[1]	✓	Axis variable for EtherCAT slave D
MC_Axis002	_sAXIS_REF		MC://_MC_AX[2]	✓	Axis variable for EtherCAT slave E
ExclusiveFlg	BOOL	FALSE		---	Instruction Exclusive Flag

LD

Internal Variables	Variable	Data type	Initial value	Comment
	Operating1End	BOOL	FALSE	Processing completed
	Trigger1	BOOL	FALSE	Execution condition
	Operating1	BOOL	FALSE	Processing

Internal Variables	Variable	Data type	Initial value	Comment
	AxisUnuseDone_DevC	BOOL	FALSE	Changing axis to unused axis completed for EtherCAT slave C
	SlaveDisableDone_DevC	BOOL	FALSE	Disabling EtherCAT slave C completed
	DoneHold_DevC	BOOL	FALSE	Holding completion of processing for EtherCAT slave C
	AxisUnuseDone_DevD	BOOL	FALSE	Changing axis to unused axis completed for EtherCAT slave D
	SlaveDisableDone_DevD	BOOL	FALSE	Disabling EtherCAT slave D completed
	DoneHold_DevD	BOOL	FALSE	Holding completion of processing for EtherCAT slave D
	AxisUnuseDone_DevE	BOOL	FALSE	Changing axis to unused axis completed for EtherCAT slave E
	SlaveDisableDone_DevE	BOOL	FALSE	Disabling EtherCAT slave E completed
	DoneHold_DevE	BOOL	FALSE	Holding completion of processing for EtherCAT slave E
	Light1On	BOOL	FALSE	Lighting removal OK lamp
	MC_ChangeAxisUse_DevC	MC_ChangeAxisUse		
	EC_ChangeEnableSetting_DevC	EC_ChangeEnableSetting		
	MC_ChangeAxisUse_DevD	MC_ChangeAxisUse		
	EC_ChangeEnableSetting_DevD	EC_ChangeEnableSetting		
	MC_ChangeAxisUse_DevE	MC_ChangeAxisUse		
	EC_ChangeEnableSetting_DevE	EC_ChangeEnableSetting		

External Variables	Variable	Data type	Constant	Comment
	MC_Axis000	_sAXIS_REF	✓	Axis variable for EtherCAT slave C
	MC_Axis001	_sAXIS_REF	✓	Axis variable for EtherCAT slave D
	MC_Axis002	_sAXIS_REF	✓	Axis variable for EtherCAT slave E
	ExclusiveFlg	BOOL	---	Instruction Exclusive Flag

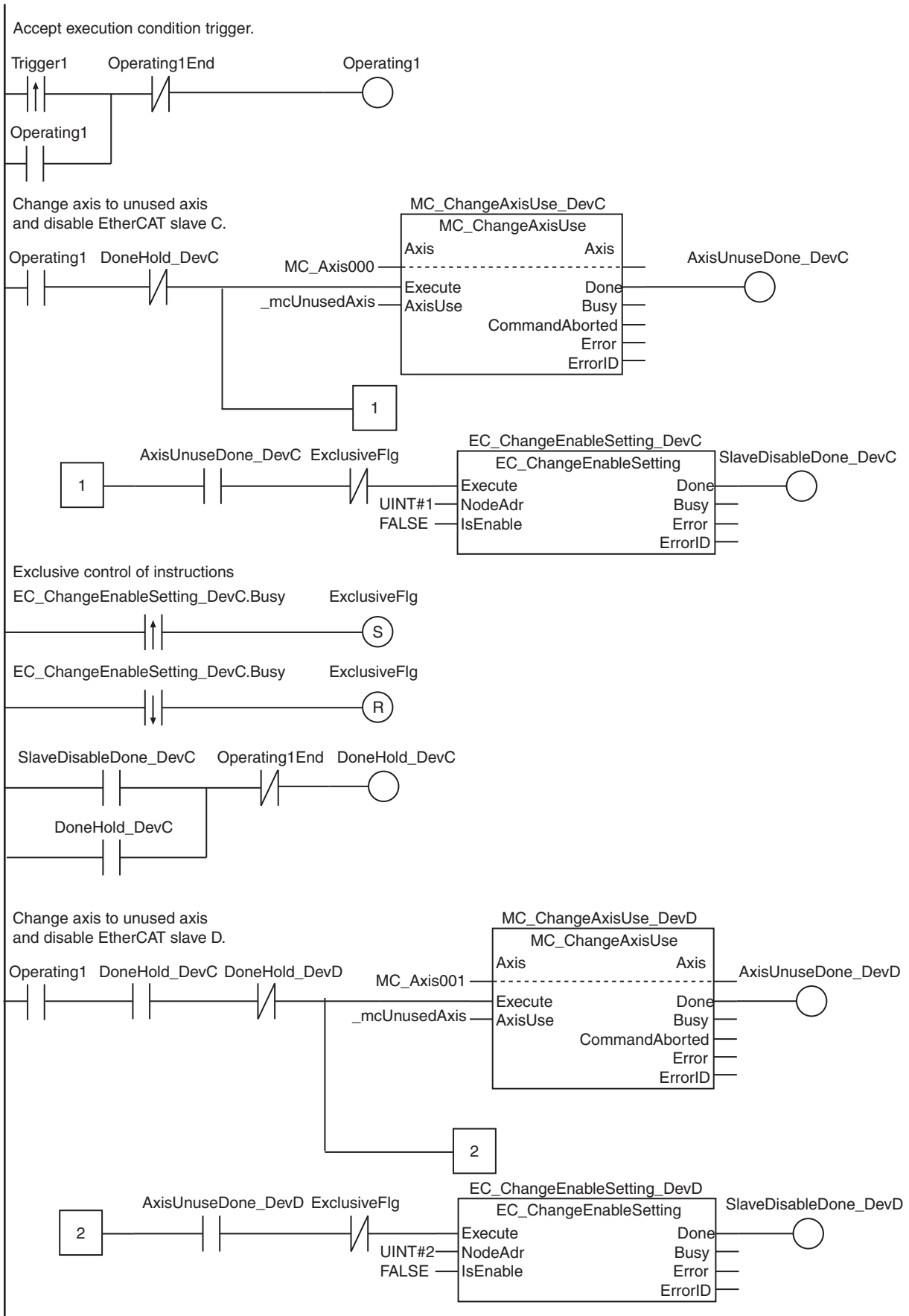

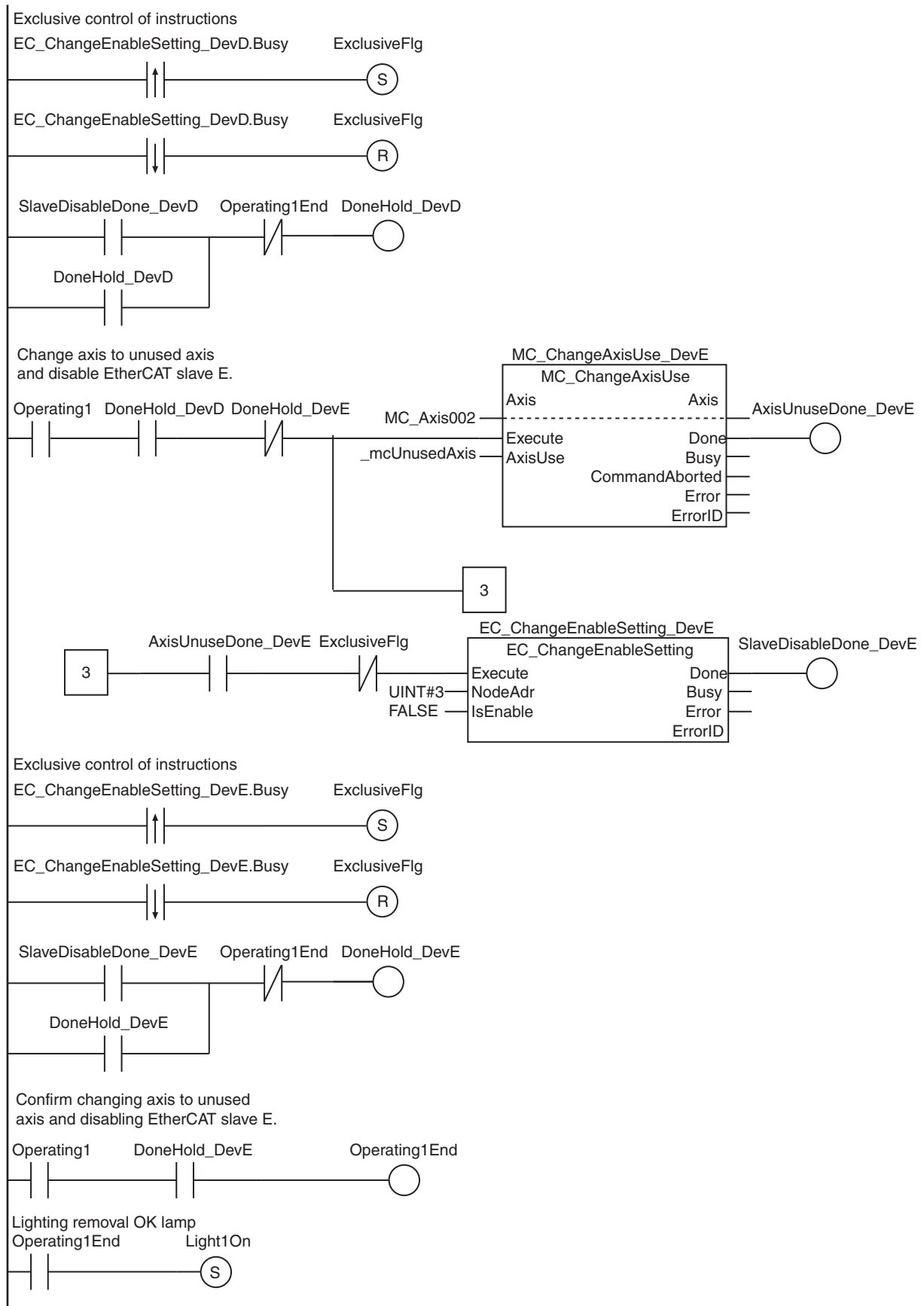

ST

Internal Variables	Variable	Data type	Initial value	Comment
	Operating1End	BOOL	FALSE	Processing completed
	Trigger1	BOOL	FALSE	Execution condition
	Operating1	BOOL	FALSE	Processing
	Operating1Set	BOOL	FALSE	Processing started
	Light1On	BOOL	FALSE	Lighting removal OK lamp
	DoneHold_DevC	BOOL	FALSE	Holding completion of processing for EtherCAT slave C
	DoneHold_DevD	BOOL	FALSE	Holding completion of processing for EtherCAT slave D
	DoneHold_DevE	BOOL	FALSE	Holding completion of processing for EtherCAT slave E
	ExclusiveFlgSet	BOOL	FALSE	Instruction Exclusive Flag ON
	ExclusiveFlgReset	BOOL	FALSE	Instruction Exclusive Flag OFF
	R_TRIG_instance1	R_TRIG		
	RS_instance1	RS		
	SR_instance1	SR		
	MC_ChangeAxisUse_DevC	MC_ChangeAxisUse		
	EC_ChangeEnableSetting_DevC	EC_ChangeEnableSetting		
	R_TRIG_DevC	R_TRIG		
	F_TRIG_DevC	F_TRIG		
	RS_ExFlg_DevC	RS		
	RS_DevC	RS		
	MC_ChangeAxisUse_DevD	MC_ChangeAxisUse		
	EC_ChangeEnableSetting_DevD	EC_ChangeEnableSetting		
	R_TRIG_DevD	R_TRIG		
	F_TRIG_DevD	F_TRIG		
	RS_ExFlg_DevD	RS		
	RS_DevD	RS		
	MC_ChangeAxisUse_DevE	MC_ChangeAxisUse		
	EC_ChangeEnableSetting_DevE	EC_ChangeEnableSetting		
	R_TRIG_DevE	R_TRIG		
	F_TRIG_DevE	F_TRIG		
	RS_ExFlg_DevE	RS		
	RS_DevE	RS		

External Variables	Variable	Data type	Constant	Comment
	MC_Axis000	_sAXIS_REF	✓	Axis variable for EtherCAT slave C
	MC_Axis001	_sAXIS_REF	✓	Axis variable for EtherCAT slave D
	MC_Axis002	_sAXIS_REF	✓	Axis variable for EtherCAT slave E
	ExclusiveFlg	BOOL	---	Instruction Exclusive Flag

```

// Accept execution condition trigger.
R_TRIG_instancel(Trigger1, Operating1Set);
RS_instancel(
    Set      :=Operating1Set,
    Reset1:=Operating1End,
    Q1      =>Operating1);

// Change axis to unused axis for EtherCAT slave C.
MC_ChangeAxisUse_DevC(
    Axis      :=MC_Axis000,
    Execute:=(Operating1 & NOT(DoneHold_DevC)),
    AxisUse:=_mcUnusedAxis);

// Disable EtherCAT slave C.
EC_ChangeEnableSetting_DevC(
    Execute :=(Operating1 & MC_ChangeAxisUse_DevC.Done & NOT(ExclusiveFlg)),
    NodeAdr :=UINT#1,
    IsEnable:=FALSE);

// Exclusive control of instructions
R_TRIG_DevC(EC_ChangeEnableSetting_DevC.Busy, ExclusiveFlgSet);
F_TRIG_DevC(EC_ChangeEnableSetting_DevC.Busy, ExclusiveFlgReset);
RS_ExFlg_DevC(
    Set      :=ExclusiveFlgSet,
    Reset1:=ExclusiveFlgReset,
    Q1      =>ExclusiveFlg);
RS_DevC(
    Set      :=EC_ChangeEnableSetting_DevC.Done,
    Reset1:=Operating1End,
    Q1      =>DoneHold_DevC);

// Change axis to unused axis for EtherCAT slave D.
MC_ChangeAxisUse_DevD(
    Axis      :=MC_Axis001,
    Execute:=(Operating1 & DoneHold_DevC & NOT(DoneHold_DevD)),
    AxisUse:=_mcUnusedAxis);

// Disable EtherCAT slave D.
EC_ChangeEnableSetting_DevD(
    Execute :=(Operating1 & DoneHold_DevC & MC_ChangeAxisUse_DevD.Done &
        NOT(ExclusiveFlg)),
    NodeAdr :=UINT#2,
    IsEnable:=FALSE);

// Exclusive control of instructions
R_TRIG_DevD(EC_ChangeEnableSetting_DevD.Busy, ExclusiveFlgSet);
F_TRIG_DevD(EC_ChangeEnableSetting_DevD.Busy, ExclusiveFlgReset);
RS_ExFlg_DevD(
    Set      :=ExclusiveFlgSet,
    Reset1:=ExclusiveFlgReset,
    Q1      =>ExclusiveFlg);
RS_DevD(
    Set      :=EC_ChangeEnableSetting_DevD.Done,
    Reset1:=Operating1End,
    Q1      =>DoneHold_DevD);

// Change axis to unused axis for EtherCAT slave E.
MC_ChangeAxisUse_DevE(
    Axis      :=MC_Axis002,
    Execute:=(Operating1 & DoneHold_DevD & NOT(DoneHold_DevE)),
    AxisUse:=_mcUnusedAxis);

// Disable EtherCAT slave E.
EC_ChangeEnableSetting_DevE(

```



```

Execute :=(Operating1 & DoneHold_DevD & MC_ChangeAxisUse_DevE.Done &
          NOT(ExclusiveFlg)),
NodeAdr :=UINT#3,
IsEnable:=FALSE);

// Exclusive control of instructions
R_TRIG_DevE(EC_ChangeEnableSetting_DevE.Busy, ExclusiveFlgSet);
F_TRIG_DevE(EC_ChangeEnableSetting_DevE.Busy, ExclusiveFlgReset);
RS_ExFlg_DevE(
  Set :=ExclusiveFlgSet,
  Reset1:=ExclusiveFlgReset,
  Q1 =>ExclusiveFlg);
RS_DevE(
  Set :=EC_ChangeEnableSetting_DevE.Done,
  Reset1:=Operating1End,
  Q1 =>DoneHold_DevE);

// Confirm changing axis to unused axis and disabling EtherCAT slave E.
Operating1End:=(Operating1 & DoneHold_DevE);

// Lighting removal OK lamp
SR_instance1(
  Set1:=Operating1End,
  Q1 =>Light1On);

```

● Example of Connecting EtherCAT Slaves to an EtherCAT Network

Production line 1 from the previous example is left running while EtherCAT slaves F and G are installed on production line 2. Motion control axes are set for EtherCAT slaves F and G. Therefore, the EtherCAT slaves are enabled and the axes are changed to used axes.

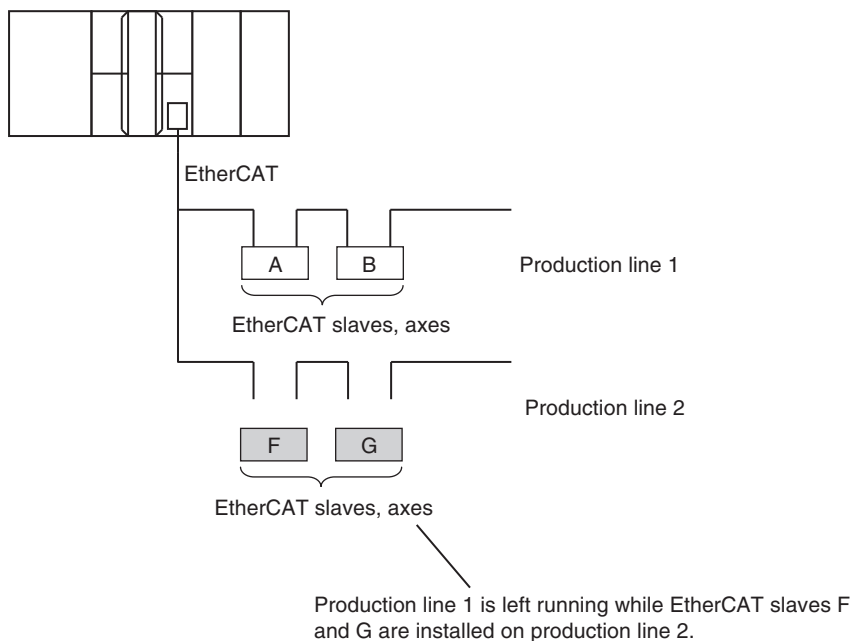

Procedure

The operating procedure for the sample programming is as follows:

- 1** The operator uses the following procedure to install EtherCAT slaves F and G.
- 2** The operator presses a button on an HMI to turn ON the execution condition.

- 3 The Controller enables EtherCAT slaves F and G. Also, the axes for those slaves are changed to used axes.
- 4 When enabling and changing the axes to used axes is completed for the two EtherCAT slaves, the Controller lights an installation completed lamp.

Instruction to Change Axes to Used Axes

The MC_ChangeAxisUse instruction is used to change axes to used axes. Refer to the *NJ/NX-series Motion Control Instructions Reference Manual* (Cat. No. W508) or *NY-series Motion Control Instructions Reference Manual* (Cat. No. W561) for the detailed specifications of the MC_ChangeAxisUse instruction.

Exclusive Control of Instructions

You can execute only one EC_ChangeEnableSetting instruction at the same time. Also, the EC_ChangeEnableSetting instruction is executed over more than one task. Confirm the completion of the EC_ChangeEnableSetting instruction before you execute the next EC_ChangeEnableSetting instruction. The *ExclusiveFlg* variable (Instruction Exclusive Flag) is used for this purpose. If the value of *ExclusiveFlg* is TRUE, then an EC_ChangeEnableSetting instruction is in execution. Do not execute the next EC_ChangeEnableSetting instruction while the value of *ExclusiveFlg* is TRUE.

You cannot execute the EC_ChangeEnableSetting instruction at the same time as another EC_ChangeEnableSetting instruction is in execution in another task. Therefore, *ExclusiveFlg* is defined as a global variable in this sample programming. That allows this sample programming to perform exclusive control with EC_ChangeEnableSetting instructions in the other tasks. The same global variable, *ExclusiveFlg*, must also be used in the other tasks to perform exclusive control of the instructions.

You cannot execute the EC_ChangeEnableSetting instruction at the same time as the EC_DisconnectSlave or EC_ConnectSlave instruction. The sample programming that is provided for the EC_DisconnectSlave instruction on page 2-946 uses the same *ExclusiveFlg* global variable as in this sample programming as an example of exclusive control of instructions.

Axis Variables and Node Addresses for the EtherCAT Slaves

The axis variables that are assigned to the axes for EtherCAT slaves F and G and the node addresses of the slaves are given in the following table.

EtherCAT slaves	Axis variable	Node address
F	MC_Axis003	4
G	MC_Axis004	5

Definitions of Global Variables

Global Variables

Variable	Data type	Initial value	AT specification	Constant	Comment
MC_Axis003	_sAXIS_REF		MC://_MC_AX[3]	✓	Axis variable for EtherCAT slave F
MC_Axis004	_sAXIS_REF		MC://_MC_AX[4]	✓	Axis variable for EtherCAT slave G
ExclusiveFlg	BOOL	FALSE		---	Instruction Exclusive Flag

LD

Internal Variables	Variable	Data type	Initial value	Comment
	Operating2End	BOOL	FALSE	Processing completed
	Trigger2	BOOL	FALSE	Execution condition
	Operating2	BOOL	FALSE	Processing
	AxisUseDone_DevF	BOOL	FALSE	Changing axis to used axis completed for EtherCAT slave F
	SlaveEnableDone_DevF	BOOL	FALSE	Enabling EtherCAT slave F completed
	DoneHold_DevF	BOOL	FALSE	Holding completion of processing for EtherCAT slave F
	AxisUseDone_DevG	BOOL	FALSE	Changing axis to used axis completed for EtherCAT slave G
	SlaveEnableDone_DevG	BOOL	FALSE	Enabling EtherCAT slave G completed
	DoneHold_DevG	BOOL	FALSE	Holding completion of processing for EtherCAT slave G
	Light2On	BOOL	FALSE	Lighting installation completed lamp
	MC_ChangeAxisUse_DevF	MC_ChangeAxisUse		
	EC_ChangeEnableSetting_DevF	EC_ChangeEnableSetting		
	MC_ChangeAxisUse_DevG	MC_ChangeAxisUse		
	EC_ChangeEnableSetting_DevG	EC_ChangeEnableSetting		

External Variables	Variable	Data type	Constant	Comment
	MC_Axis003	_sAXIS_REF	✓	Axis variable for EtherCAT slave F
	MC_Axis004	_sAXIS_REF	✓	Axis variable for EtherCAT slave G
	ExclusiveFlg	BOOL	---	Instruction Exclusive Flag

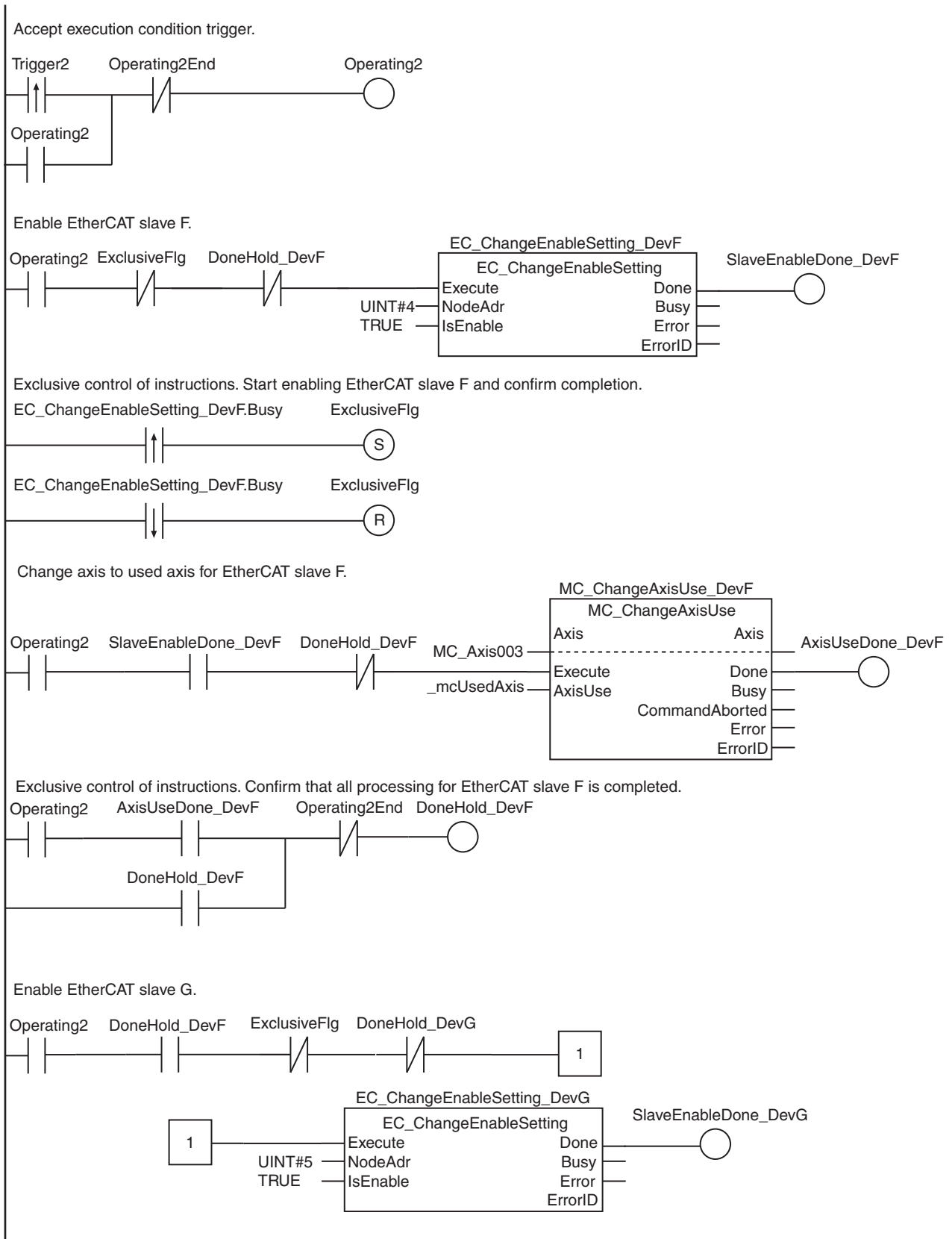

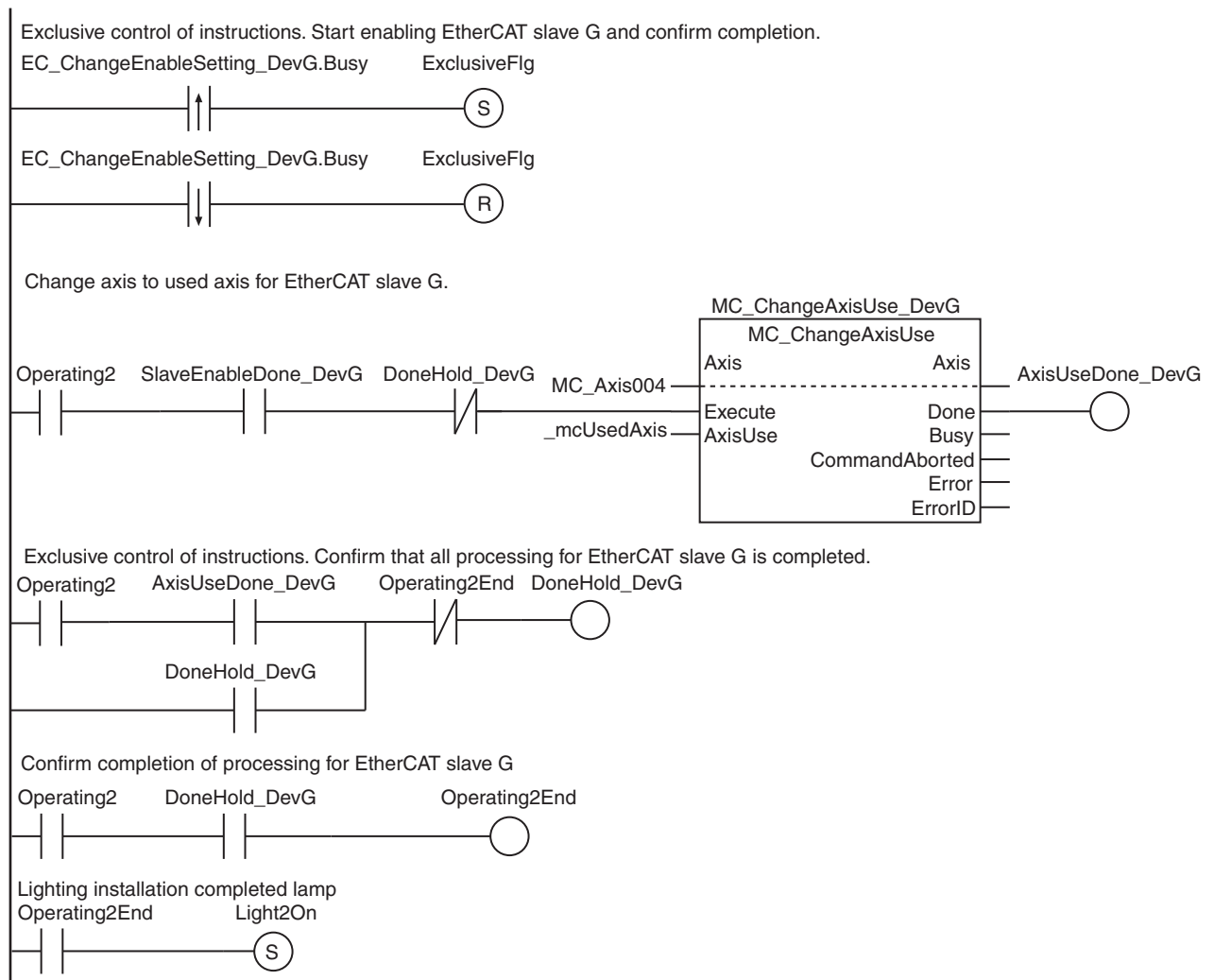

ST

Internal Variables	Variable	Data type	Initial value	Comment
	Operating2End	BOOL	FALSE	Processing completed
	Trigger2	BOOL	FALSE	Execution condition
	Operating2	BOOL	FALSE	Processing
	Operating2Set	BOOL	FALSE	Processing started
	Light2On	BOOL	FALSE	Lighting installation completed lamp
	DoneHold_DevF	BOOL	FALSE	Holding completion of processing for EtherCAT slave F
	DoneHold_DevG	BOOL	FALSE	Holding completion of processing for EtherCAT slave G
	ExclusiveFlgSet	BOOL	FALSE	Instruction Exclusive Flag ON
	ExclusiveFlgReset	BOOL	FALSE	Instruction Exclusive Flag OFF
	R_TRIG_instance2	R_TRIG		
	RS_instance2	RS		
	SR_instance2	SR		
	MC_ChangeAxisUse_DevF	MC_ChangeAxisUse		

Internal Variables	Variable	Data type	Initial value	Comment
	EC_ChangeEnableSetting_DevF	EC_ChangeEnableSetting		
	R_TRIG_DevF	R_TRIG		
	F_TRIG_DevF	F_TRIG		
	RS_ExFlg_DevF	RS		
	RS_DevF	RS		
	MC_ChangeAxisUse_DevG	MC_ChangeAxisUse		
	EC_ChangeEnableSetting_DevG	EC_ChangeEnableSetting		
	R_TRIG_DevG	R_TRIG		
	F_TRIG_DevG	F_TRIG		
	RS_ExFlg_DevG	RS		
	RS_DevG	RS		

External Variables	Variable	Data type	Constant	Comment
	MC_Axis003	_sAXIS_REF	✓	Axis variable for EtherCAT slave F
	MC_Axis004	_sAXIS_REF	✓	Axis variable for EtherCAT slave G
	ExclusiveFlg	BOOL	---	Instruction Exclusive Flag

```

// Accept execution condition trigger.
R_TRIG_instance2(Trigger2, Operating2Set);
RS_instance2(
    Set :=Operating2Set,
    Reset1:=Operating2End,
    Q1 =>Operating2);

// Enable EtherCAT slave F.
EC_ChangeEnableSetting_DevF(
    Execute :=(Operating2 & NOT(ExclusiveFlg) & NOT(DoneHold_DevF)),
    NodeAdr :=UINT#4,
    IsEnable:=TRUE);

// Exclusive control of instructions. Start enabling EtherCAT slave F and confirm
// completion.
R_TRIG_DevF(EC_ChangeEnableSetting_DevF.Busy, ExclusiveFlgSet);
F_TRIG_DevF(EC_ChangeEnableSetting_DevF.Busy, ExclusiveFlgReset);
RS_ExFlg_DevF(
    Set :=ExclusiveFlgSet,
    Reset1:=ExclusiveFlgReset,
    Q1 =>ExclusiveFlg);

// Change axis to used axis for EtherCAT slave F.
MC_ChangeAxisUse_DevF(
    Axis :=MC_Axis003,
    Execute:=(Operating2 & EC_ChangeEnableSetting_DevF.Done & NOT(DoneHold_DevF)),
    AxisUse:=_mcUsedAxis);

// Exclusive control of instructions. Confirm that all processing for EtherCAT
// slave F is completed.
RS_DevF(
    Set :=(Operating2 & MC_ChangeAxisUse_DevF.Done),
    Reset1:=Operating2End,
    Q1 =>DoneHold_DevF);

// Enable EtherCAT slave G.
EC_ChangeEnableSetting_DevG(

```

```

Execute :=(Operating2 & DoneHold_DevF & NOT(ExclusiveFlg) &
          NOT(DoneHold_DevG)),
NodeAdr :=UINT#5,
IsEnable:=TRUE);

// Exclusive control of instructions. Start enabling EtherCAT slave F and confirm
// completion.
R_TRIG_DevG(EC_ChangeEnableSetting_DevG.Busy, ExclusiveFlgSet);
F_TRIG_DevG(EC_ChangeEnableSetting_DevG.Busy, ExclusiveFlgReset);
RS_ExFlg_DevG(
  Set    :=ExclusiveFlgSet,
  Reset1:=ExclusiveFlgReset,
  Q1     =>ExclusiveFlg);

// Change axis to used axis for EtherCAT slave G.
MC_ChangeAxisUse_DevG(
  Axis    :=MC_Axis004,
  Execute:=(Operating2 & EC_ChangeEnableSetting_DevG.Done & NOT(DoneHold_DevG)),
  AxisUse:=_mcUsedAxis);

// Exclusive control of instructions. Confirm that all processing for EtherCAT
// slave G is completed.
RS_DevG(
  Set    :=(Operating2 & MC_ChangeAxisUse_DevG.Done),
  Reset1:=Operating2End,
  Q1     =>DoneHold_DevG);

// Confirm completion of processing for EtherCAT slave G
Operating2End:=Operating2 & DoneHold_DevG;

// Lighting installation completed lamp
SR_instance2(
  Set1:=Operating2End,
  Q1  =>Light2On);

```

NX_WriteObj

The NX_WriteObj instruction writes data to an NX object in an EtherCAT Coupler Unit or NX Unit.

Instruction	Name	FB/FUN	Graphic expression	ST expression
NX_WriteObj	Write NX Unit Object	FB		NX_WriteObj_instance(Execute, UnitProxy, Obj, TimeOut, WriteDat, Done, Busy, Error, ErrorID, ErrorIDEx);

Variables

Name	Meaning	I/O	Description	Valid range	Unit	Default
UnitProxy	Specified Unit	Input	Unit to which to write data	---	---	*
Obj	Object parameter		Object parameter			---
TimeOut	Timeout time		Timeout time	0 to 60,000	ms	2000 (2.0s)
WriteDat	Write data		If 0 is set, the timeout time is 2.0 s.	Depends on data type.	---	*

* If you omit the input parameter, the default value is not applied. A building error will occur.

	Boolean	Bit strings				Integers							Real numbers	Times, durations, dates, and text strings						
	BOOL	BYTE	WORD	DWORD	LWORD	USINT	UINT	UDINT	ULINT	SINT	INT	DINT	LINT	REAL	LREAL	TIME	DATE	TOD	DT	STRING
UnitProxy	Refer to <i>Function</i> for details on the structure <code>_sNXUNIT_ID</code> .																			
Obj	Refer to <i>Function</i> for details on the structure <code>_sNXOBJ_ACCESS</code> .																			
TimeOut							OK													
WriteDat	OK	OK	OK	OK	OK	OK	OK	OK	OK	OK	OK	OK	OK	OK	OK	OK	OK	OK	OK	OK
	An array can also be specified.																			

Function

The NX_WriteObj instruction writes the contents of *WriteDat* to an NX object in an EtherCAT Coupler Unit, an NX Unit on the EtherCAT Coupler Unit, or an NX Unit connected to the NX bus of the CPU Unit. The Unit for which to write the data is specified with *UnitProxy*.

TimeOut specifies the timeout time. If a response does not return within the timeout time, it is assumed that communications failed. In that case, the data is not written.

The data type of *UnitProxy* is structure `_sNXUNIT_ID`. The meanings of the members are as follows:

Name	Meaning	Content	Data type
UnitProxy	Specified Unit	Specified Unit	<code>_sNXUNIT_ID</code>
NodeAdr	Node address	Node address of the Communications Coupler Unit	UINT
IPAdr	IP address	IP address of the Communications Coupler Unit	BYTE[5]
UnitNo	Unit number	Unit number of specified Unit	UDINT
Path	Path	Path information to the specified Unit	BYTE[64]
PathLength	Valid path length	Valid path length	USINT

Pass the device variable that is assigned to the specified Unit to *UnitProxy*.

The data type of *Obj* is structure `_sNXOBJ_ACCESS`. The meanings of the members are as follows:

Name	Meaning	Description	Data type	Valid range	Unit	Default
Obj	Object parameter	Object parameter	<code>_sNXOBJ_ACCESS</code>	---	---	---
Index	Index	Index	UINT	Depends on data type.	---	0
Subindex	Subindex	Subindex	USINT			
IsCompleteAccess*1	Complete access	Complete access	BOOL	FALSE only		FALSE

*1 This member is not used for this instruction. Always set the value to FALSE.

Related Instructions and Execution Procedure

Depending on the attributes of the data that you write to an EtherCAT Coupler Unit, an NX Unit on the EtherCAT Coupler Unit, or an NX Unit connected to the NX bus of the CPU Unit, you must execute this instruction along with other instructions. The procedures for each case are given below.

● Execution Procedure 1

Use the following procedure to write data with the following attributes.

- Power OFF Retain attribute
- The values are updated when the Unit is restarted.

- 1** Use the `NX_ChangeWriteMode` instruction (page 2-866) to change the Unit to a mode that allows writing data.
- 2** Use the `NX_WriteObj` instruction to write data to the Unit.
- 3** Use the `NX_SaveParam` instruction (page 2-871) to save the data that you wrote.
- 4** Use the `RestartNXUnit` instruction (page 2-860) to restart the Unit.

● Execution Procedure 2

Use the following procedure to write data with the following attributes.

- Power OFF Retain attribute
- The values are updated as soon as they are written.

- 1 Use the NX_WriteObj instruction to write data to the Unit.
- 2 Use the NX_SaveParam instruction (page 2-871) to save the data that you wrote.

● **Execution Procedure 3**

Use the following procedure to write data with the following attributes.

- No Power OFF Retain attribute

- 1 Use the NX_WriteObj instruction to write data to the Unit.

Notation Example

The following notation example shows how to set the NX-OD4121 Digital Output Unit to hold the present value of the output when the load becomes disconnected.

A variable that is named 'NX1' with a data type of _sNXUNIT_ID is assigned to the Unit to which to write the data.

For the NX-OD4121, the index of the Load OFF Output Setting parameter is UINT#16#5011 and the subindex is USINT#1.

To hold the present value, BYTE#16#01 is written to the Load Rejection Output Setting parameter.

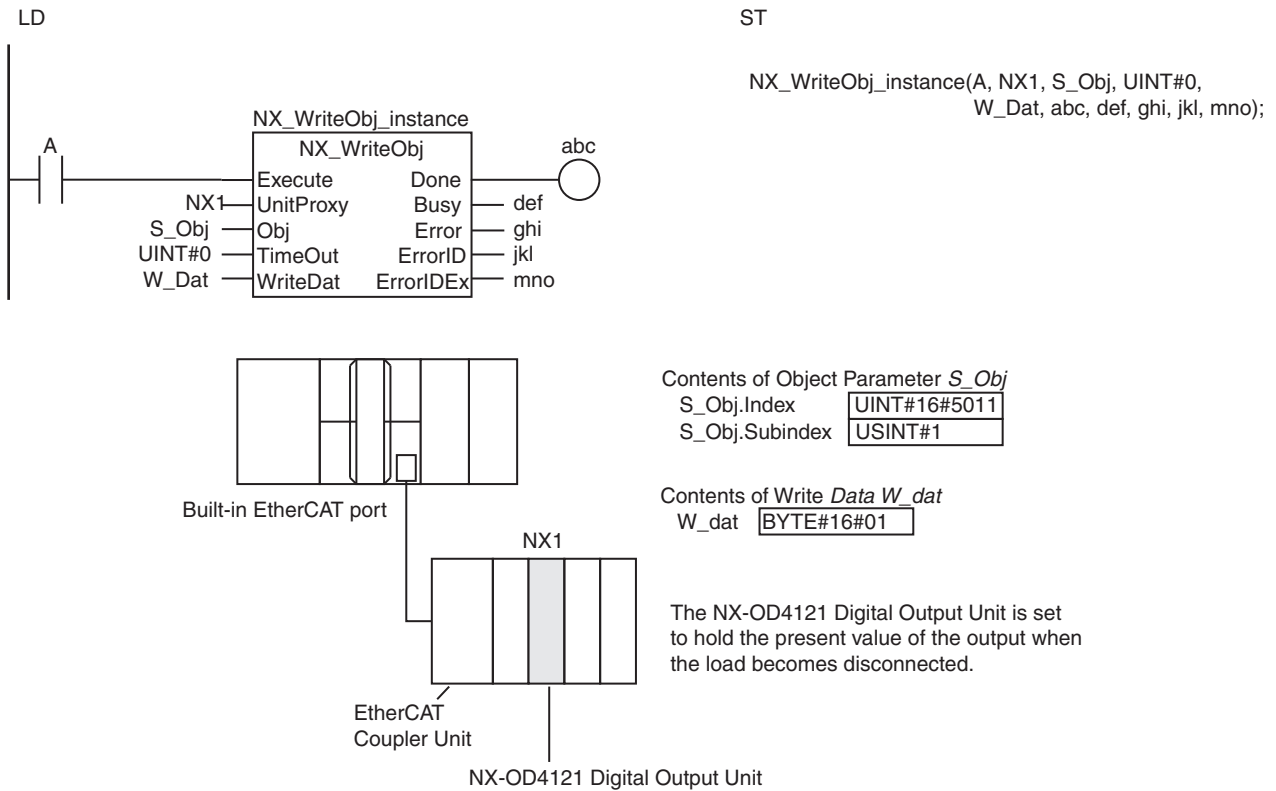

Contents of Object Parameter *S_Obj*

S_Obj.Index	UINT#16#5011
S_Obj.Subindex	USINT#1

Contents of Write Data *W_dat*

W_dat	BYTE#16#01
-------	------------

The NX-OD4121 Digital Output Unit is set to hold the present value of the output when the load becomes disconnected.

Related System-defined Variables

Name	Meaning	Data type	Description
_EC_MBXSlavTbl[i] “i” is the node address.	Message Communications Enabled Slave Table	BOOL	This variable indicates whether communications are possible for each slave. TRUE: Communications are possible. FALSE: Communications are not possible.
_NXB_UnitMsgActiveTbl [i]	NX Unit Message Enabled Status	BOOL	This table indicates the slaves that can perform message communications. Use this variable to confirm that communications with the relevant slave are possible.

Precautions for Correct Use

- Execution of this instruction is continued until processing is completed even if the value of *Execute* changes to FALSE or the execution time exceeds the task period. The value of *Done* changes to TRUE when processing is completed. Use this to confirm normal completion of processing.
- Refer to *Using this Section* (page 2-3) for a timing chart for *Execute*, *Done*, *Busy*, and *Error*.
- If *WriteDat* is an array, make sure that the overall size of the array is the same as the size of the NX object to write in the specified Unit.
- For *UnitProxy*, specify the device variable that is assigned to an EtherCAT Coupler Unit, an NX Unit on the EtherCAT Coupler Unit, or an NX Unit connected to the NX bus of the CPU Unit in the I/O Map of the Sysmac Studio. Refer to the *Sysmac Studio Version 1 Operation Manual* (Cat. No. W504-E1-07 or later) for details on assigning device variables.
- Always use a variable for the parameter to pass to *WriteDat*. A building error will occur if a constant is passed.
- To write and save data with a Power OFF Retain attribute, execute the *NX_SaveParam* instruction (page 2-871) after you execute the *NX_WriteObj* instruction. If you restart the Unit before you execute the *NX_SaveParam* instruction, the previous NX object data is restored.
- This instruction is related to NX Message Communications Errors. If too many instructions that are related to NX Message Communications Errors are executed at the same time, an NX Message Communications Error will occur. Refer to *Instructions Related to NX Message Communications Errors* (page A-214) for a list of the instructions that are related to NX Message Communications Errors.

- *Error* is TRUE if an error occurred. The meanings of the values of *ErrorID* and *ErrorIDEx* are given in the following table.

Value of <i>ErrorID</i>	Value of <i>ErrorIDEx</i>	Meaning
16#0400	16#00000000	<ul style="list-style-type: none"> • The value of <i>UnitProxy</i> is outside of the valid range. • The value of <i>TimeOut</i> is outside of the valid range.
16#0419	16#00000000	<ul style="list-style-type: none"> • The data type of <i>UnitProxy</i> is not correct. • The data type of <i>WriteDat</i> is not correct.
16#041B	16#00000000	More than 2,048 bytes of data was specified for <i>WriteDat</i> .
16#2C00	16#00000401	The specified Unit does not support the instruction.
	16#00001001 16#00001002 16#00170000 16#00200000 16#00210000	An input parameter, output parameter, or in-out parameter is incorrect. Confirm that the intended parameter is used for the input parameter, output parameter, or in-out parameter.
	16#00001010	The data size of the specified NX object does not agree with the data size specified in <i>WriteDat</i> .
	16#00001101	The correct Unit was not specified. Check the Unit.
	16#0000110B	The size of the read data is too large. Make sure that the read data specification is correct.
	16#00001110	There is no object that corresponds to the value of <i>Obj.Index</i> .
	16#00001111	There is no object that corresponds to the value of <i>Obj.Subindex</i> .
	16#00002101	The specified NX object cannot be written.
	16#00002110	The value of <i>WriteDat</i> exceeds the range of the values of the NX object to write.
	16#00002210	The specified Unit is not in a mode that allows writing data.
	16#00002213	Instruction execution was not possible because the specified Unit was performing an I/O check. Execute the instruction after the I/O check is completed.
	16#00002230	<p>The status of the specified Unit does not agree with the value of the read source or write destination NX object. Take the following actions if the value of <i>Obj.Index</i> is between 0x6000 and 0x6FFF or between 0x7000 and 0x7FFF.</p> <ul style="list-style-type: none"> • Delete the read source or write designation NX object from the I/O allocation settings. • Reset the error for the specified Unit. • Place the specified Unit in a mode that does not allow writing data.
	16#00002231	Instruction execution was not possible because the specified Unit was performing initialization. Wait for the Unit to start normal operation and then execute the instruction.
	16#0000250F	Hardware access failed. Execute the instruction again.
	16#00002601 16#00002602 16#00100000	The specified Unit does not support this instruction. Check the version of the Unit.
	16#00002603	Execution of the instruction failed. Execute the instruction again. Make sure that at least one channel is enabled in the selections of the channels to use.
	16#00002621	The NX Unit is not in a status in which it can acknowledge the instruction. Wait for a while and then execute the instruction again.
	16#00010000	The specified Unit does not exist. Make sure that the Unit configuration is correct.
	16#00110000	The specified port number does not exist. Make sure that the Unit configuration is correct.

Value of ErrorID	Value of Error-DEx	Meaning	
16#2C00	16#00120000 16#00130000 16#00150000 16#00160000	The value of <i>UnitProxy</i> is not correct. Set the variable that indicates the specified EtherCAT Coupler Unit again.	
	16#00140000	The specified node address is not correct. Make sure that the Unit configuration is correct.	
	16#00300000 16#80010000	The specified Unit is busy. Execute the instruction again.	
	16#00310000	The specified Unit not supported for connection. Check the version of the Unit.	
	16#80000000 16#80050000 16#81010000 16#81020000 16#82020000 16#82030000 16#82060000 to 16#8FFF0000 16#90010000 to 16#FFFE0000	An error occurred in the communications network. Execute the instruction again.	
	16#80020000 16#80030000 16#81030000 16#82000000	An error occurred in the communications network. Reduce the amount of communications traffic.	
	16#80040000 16#81000000 16#82010000 16#82040000 16#82050000 16#90000000	An error occurred in the communications network. Check the Unit and cable connections. Make sure that the power supply to the Unit is ON.	
	16#2C01	16#00000000	The number of instructions that can be simultaneously executed was exceeded.
	16#2C02	16#00000000	A timeout occurred during communications.
	16#2C03	16#00000000	The size of the send message is not correct.

A CPU Unit with unit version 1.05 or later and Sysmac Studio version 1.06 or higher are required to use this instruction.

Sample Programming

● Example for Writing Data with Power OFF Retain Attribute That Is Updated at Unit Restart for an NX Unit

The following programming sets the Ch1 Input Moving Average Time object parameter for an NX-AD2203 AC Input Unit connected to an EtherCAT Coupler Unit to 500 μ s.

The node address of the EtherCAT Coupler Unit is 10.

The specifications of the Ch1 Input Moving Average Time object parameter are as follows:

Item	Value
Index	16#5004
Subindex	16#01
Setting for 500 μ s	2

The Ch1 Input Moving Average Time object parameter has a Power OFF Retain Attribute and it is updated when the Unit is restarted. Therefore, the following procedure is used.

- 1** Use the NX_ChangeWriteMode instruction to change the Unit to a mode that allows writing data.
- 2** Use the NX_WriteObj instruction to write data to the Unit.
- 3** Use the NX_SaveParam instruction to save the data that you wrote.
- 4** Use the RestartNXUnit instruction to restart the Unit.

LD

Internal Variables	Variable	Data type	Initial value	Comment
	Trigger	BOOL	FALSE	Execution condition
	ChangeCondition	BOOL	FALSE	Execution condition to change write mode
	WriteCondition	BOOL	FALSE	Execution condition to write data
	SaveCondition	BOOL	FALSE	Execution condition to save data
	RestartCondition	BOOL	FALSE	Execution condition to restart Unit
	NXUnitProxy	_sNXUNIT_ID		Unit designation for DC Input Unit
	NXUnitProxy_Coupler	_sNXUNIT_ID		Unit designation for EtherCAT Coupler Unit
	NXObject	_sNXOBJ_ACCESS	(Index:=0, Subindex:=0, IsCompleteAccess:=FALSE)	Object parameter
	VarWriteData	UINT	0	Write data
	NX_ChangeWriteMode_instance	NX_ChangeWriteMode		
	NX_WriteObj_instance	NX_WriteObj		
	NX_SaveParam_instance	NX_SaveParam		
	RestartNXUnit_instance	RestartNXUnit		

External Variables	Variable	Constant	Data type	Comment
	_EC_MBXSlavTbl	✓	ARRAY[1..512] OF BOOL *1	Message Communications Enabled Slave Table

*1 The data type is ARRAY [1..192] OF BOOL for an NJ-series CPU Unit.

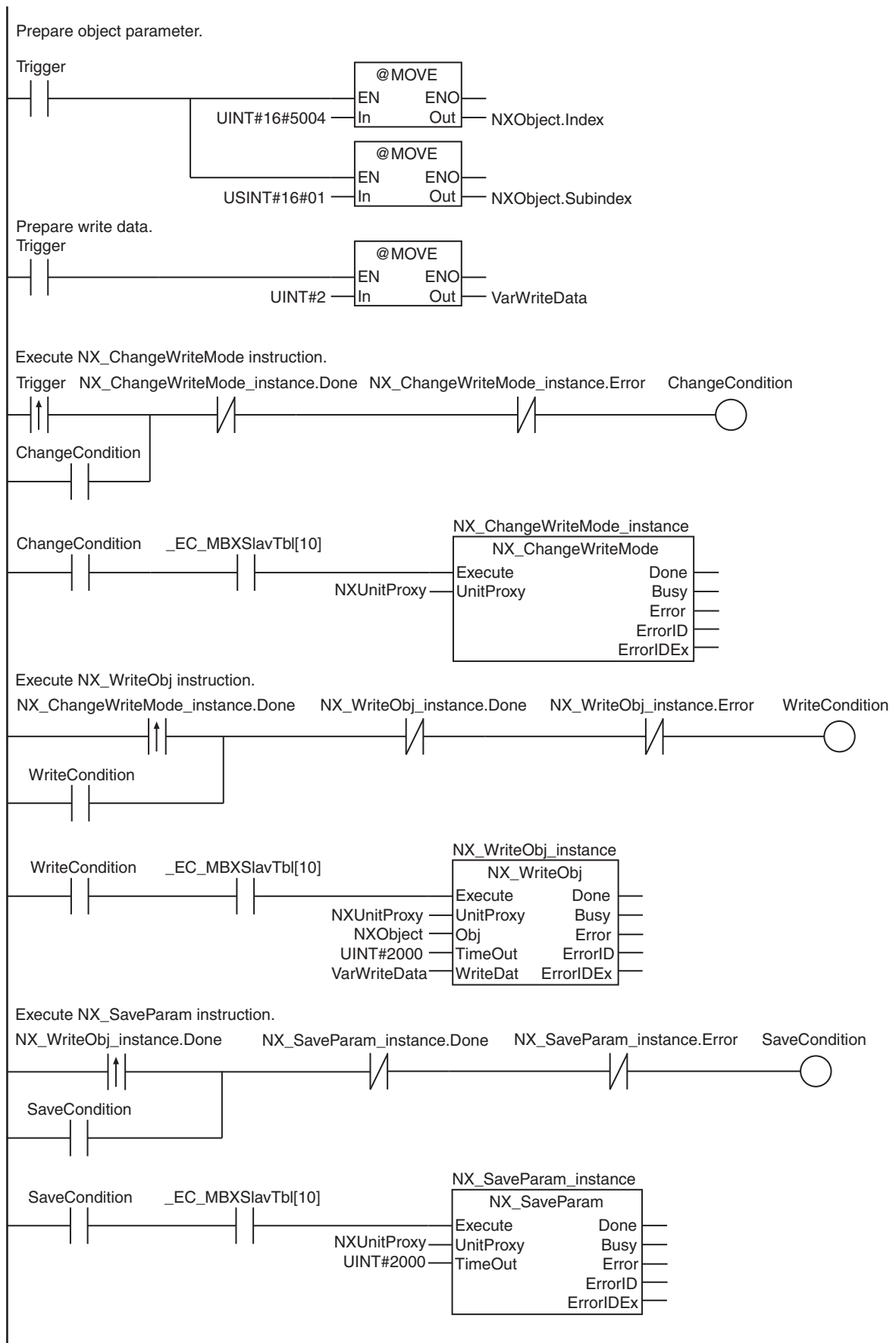

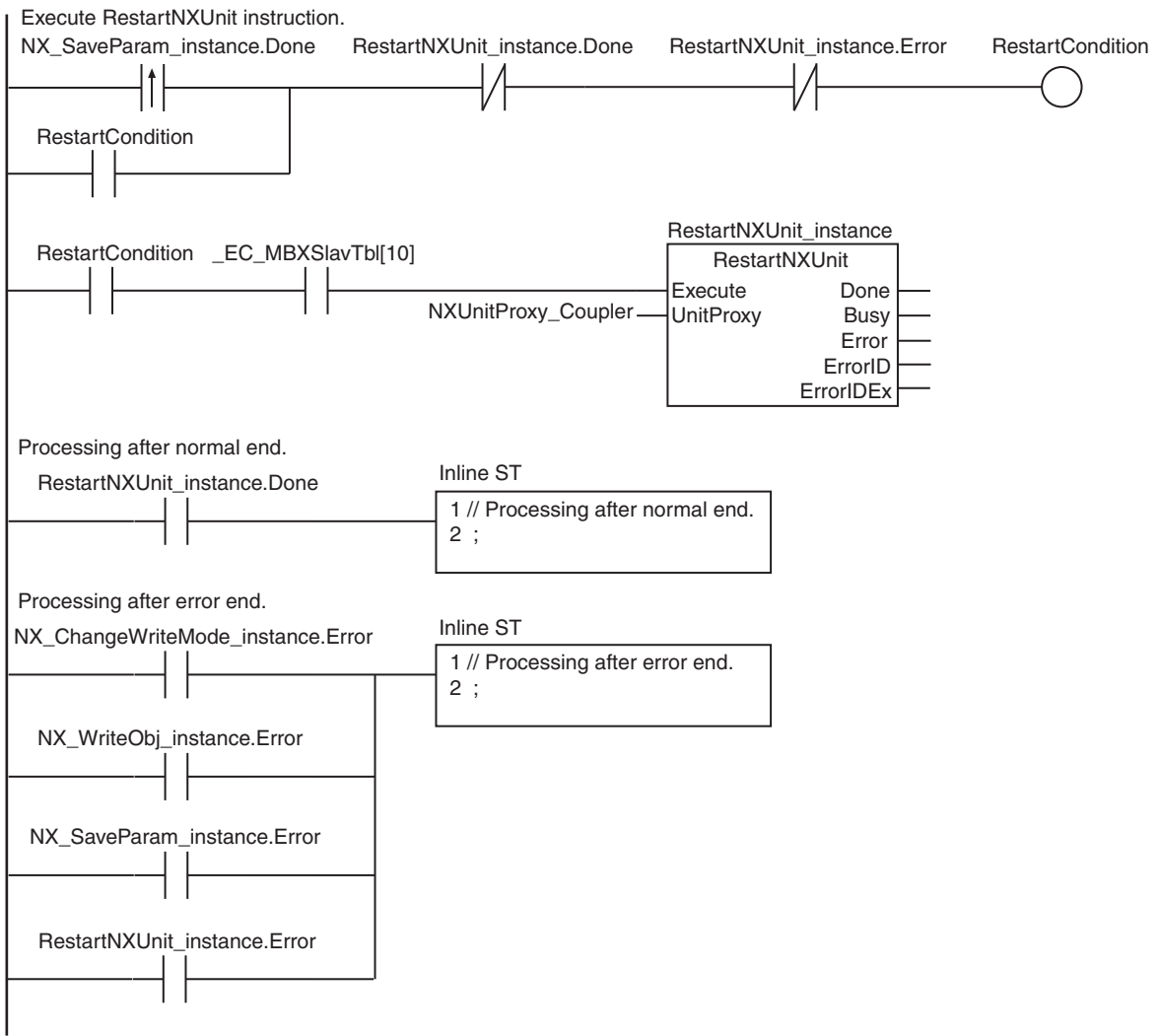

ST

Internal Variables	Variable	Data type	Initial value	Comment
	Trigger	BOOL	FALSE	Execution condition
	ChangeCondition	BOOL	FALSE	Execution condition to change write mode
	ChangeGo	BOOL	FALSE	Execution of change to write mode
	WriteCondition	BOOL	FALSE	Execution condition to write data
	WriteGo	BOOL	FALSE	Execution of data write
	SaveCondition	BOOL	FALSE	Execution condition to save data
	SaveGo	BOOL	FALSE	Execution of data save
	RestartCondition	BOOL	FALSE	Execution condition to restart Unit
	RestartGo	BOOL	FALSE	Execution of Unit restart
	NXUnitProxy	_sNXUNIT_ID		Unit designation for DC Input Unit
	NXUnitProxy_Coupler	_sNXUNIT_ID		Unit designation for EtherCAT Coupler Unit
	NXObject	_sNXOBJ_ACCESS	(Index:=0, Subindex:=0, IsCompleteAccess:=FALSE)	Object parameter
	VarWriteData	UINT	0	Write data
	NormalEnd	UINT	0	Normal end
	ErrorEnd	UINT	0	Error end
	NX_ChangeWriteMode_instance	NX_ChangeWriteMode		
	NX_WriteObj_instance	NX_WriteObj		
	NX_SaveParam_instance	NX_SaveParam		
	RestartNXUnit_instance	RestartNXUnit		
	R_Trig_instance	R_TRIG		

External Variables	Variable	Constant	Data type	Comment
	_EC_MBXSlavTbl	✓	ARRAY[1..512] OF BOOL *1	Message Communications Enabled Slave Table

*1 The data type is ARRAY [1..192] OF BOOL for an NJ-series CPU Unit.

```
// Prepare object parameter and write data.
R_Trig_instance(Clk := Trigger);
IF (R_Trig_instance.Q=TRUE) THEN
  NXObject.Index      := UINT#16#5004;
  NXObject.Subindex  := USINT#1;
  VarWriteData        := UINT#2;
END_IF;

// Execute NX_ChangeWriteMode instruction.
IF (Trigger = TRUE) THEN
  ChangeCondition := TRUE;
END_IF;

IF ((NX_ChangeWriteMode_instance.Done=TRUE) OR
(NX_ChangeWriteMode_instance.Error=TRUE)) THEN
  ChangeCondition := FALSE;
END_IF;

ChangeGo := ChangeCondition & _EC_MBXSlavTbl[10];
NX_ChangeWriteMode_instance(
  Execute      := ChangeGo,
  UnitProxy    := NXUnitProxy);
```

```

// Execute NX_WriteObj instruction.
IF (NX_ChangeWriteMode_instance.Done=TRUE) THEN
    WriteCondition := TRUE;
END_IF;

IF ((NX_WriteObj_instance.Done=TRUE) OR (NX_WriteObj_instance.Error=TRUE)) THEN
    WriteCondition := FALSE;
END_IF;

WriteGo := WriteCondition & _EC_MBXSlavTbl[10];
NX_WriteObj_instance(
    Execute := WriteGo,
    UnitProxy := NXUnitProxy,
    Obj := NXObject,
    TimeOut := UINT#2000,
    WriteDat := VarWriteData);

// Execute NX_SaveParam instruction.
IF (NX_WriteObj_instance.Done=TRUE) THEN
    SaveCondition := TRUE;
END_IF;

IF ((NX_SaveParam_instance.Done=TRUE) OR (NX_SaveParam_instance.Error=TRUE)) THEN
    SaveCondition := FALSE;
END_IF;

SaveGo := SaveCondition & _EC_MBXSlavTbl[10];
NX_SaveParam_instance(
    Execute := SaveGo,
    UnitProxy := NXUnitProxy,
    TimeOut := UINT#2000);

// Execute RestartNXUnit instruction.
IF (NX_SaveParam_instance.Done=TRUE) THEN
    RestartCondition := TRUE;
END_IF;

IF ((RestartNXUnit_instance.Done=TRUE) OR (RestartNXUnit_instance.Error=TRUE))
THEN
    RestartCondition := FALSE;
END_IF;

RestartGo := RestartCondition & _EC_MBXSlavTbl[10];
RestartNXUnit_instance(
    Execute := SaveGo,
    UnitProxy := NXUnitProxy_Coupler);

IF (RestartNXUnit_instance.Done=TRUE) THEN
    // Processing after normal end.
    NormalEnd := NormalEnd + UINT#1;
ELSIF ((NX_ChangeWriteMode_instance.Error=TRUE) OR
(NX_WriteObj_instance.Error=TRUE)
    OR (NX_SaveParam_instance.Error=TRUE) OR
(RestartNXUnit_instance.Error=TRUE)) THEN
    // Processing after error end.
    ErrorEnd := ErrorEnd + UINT#1;
END_IF;

```

● Example for Writing Data with Power OFF Retain Attribute That Is Updated after Writing the Data

The following programming sets the Ch1 Offset Value (One-point Correction) object parameter for an NX-TS2101 Temperature Input Unit connected to an EtherCAT Coupler Unit to 0.3°C.

The node address of the EtherCAT Coupler Unit is 10.

The specifications of the Ch1 Offset Value (One-point Correction) object parameter are as follows:

Item	Value
Index	16#5010
Subindex	16#01
Value to write	0.3

The Ch1 Offset Value (One-point Correction) object parameter has a Power OFF Retain Attribute and it is updated after the data is written. Therefore, the following procedure is used.

- 1** Use the NX_WriteObj instruction to write data to the Unit.
- 2** Use the NX_SaveParam instruction to save the data that you wrote.

LD

Internal Variables	Variable	Data type	Initial value	Comment
	Trigger	BOOL	FALSE	Execution condition
	WriteCondition	BOOL	FALSE	Execution condition to write data
	SaveCondition	BOOL	FALSE	Execution condition to save data
	NXUnitProxy	_sNXUNIT_ID		Unit designation for AC Input Unit
	NXUnitProxy_Coupler	_sNXUNIT_ID		Unit designation for EtherCAT Coupler Unit
	NXObject	_sNXOBJ_ACCESS	(Index:=0, Subindex:=0, IsCompleteAccess:=FALSE)	Object parameter
	VarWriteData	Real	0.0	Write data
	NX_WriteObj_instance	NX_WriteObj		
	NX_SaveParam_instance	NX_SaveParam		

External Variables	Variable	Constant	Data type	Comment
	_EC_MBXSlaveTbl	✓	ARRAY[1..512] OF BOOL *1	Message Communications Enabled Slave Table

*1 The data type is ARRAY [1..192] OF BOOL for an NJ-series CPU Unit.

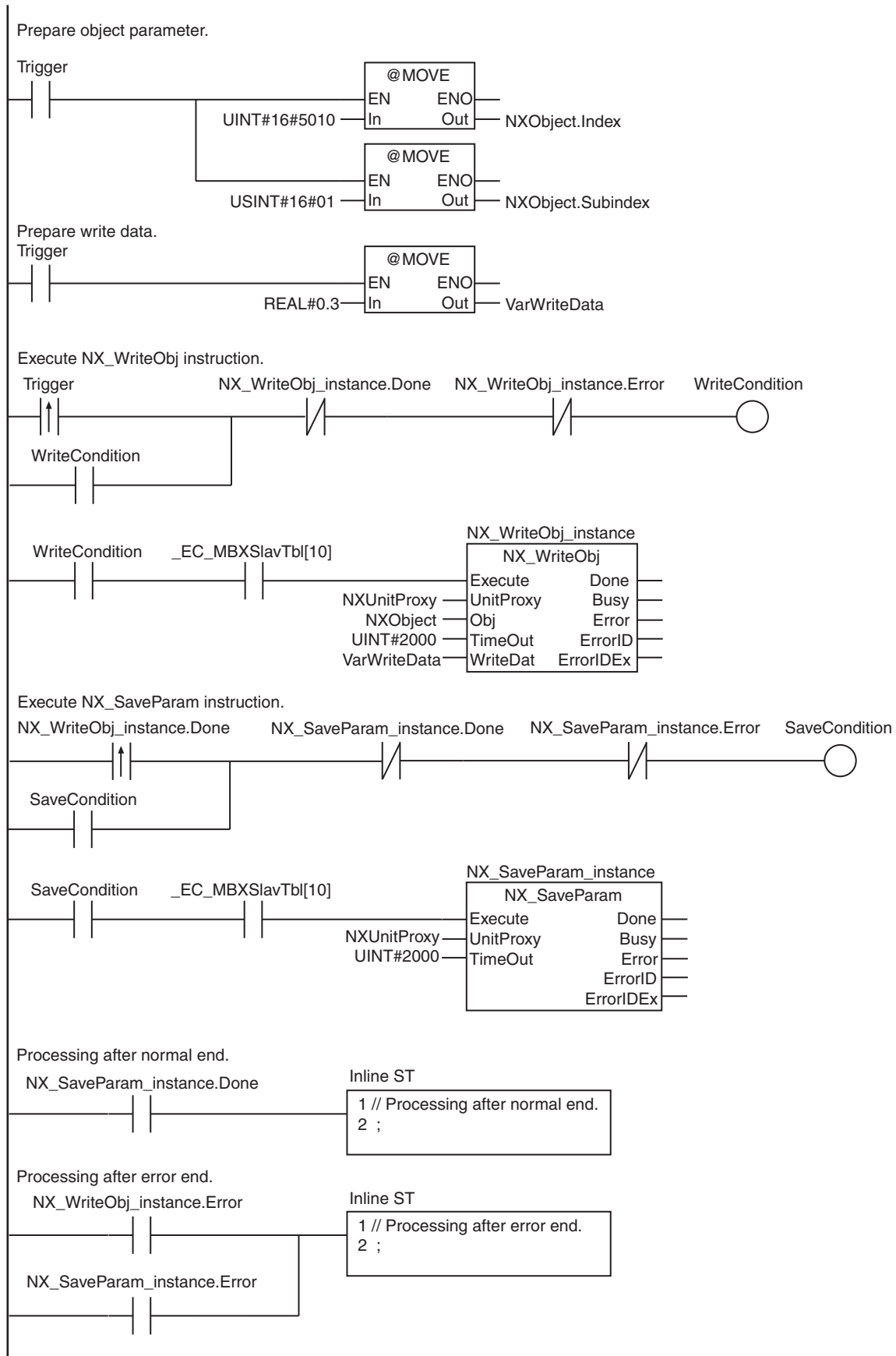

ST

Internal Variables	Variable	Data type	Initial value	Comment
	Trigger	BOOL	FALSE	Execution condition
	WriteCondition	BOOL	FALSE	Execution condition to write data
	WriteGo	BOOL	FALSE	Execution of data write
	SaveCondition	BOOL	FALSE	Execution condition to save data
	SaveGo	BOOL	FALSE	Execution of data save
	NXUnitProxy	_sNXUNIT_ID		Unit designation for Temperature Input Unit
	NXUnitProxy_Coupler	_sNXUNIT_ID		Unit designation for EtherCAT Coupler Unit
	NXObject	_sNXOBJ_ACCESS	(Index:=0, Subindex:=0, IsCompleteAccess:=FALSE)	Object parameter
	VarWriteData	REAL	0.0	Write data
	NormalEnd	UINT	0	Normal end
	ErrorEnd	UINT	0	Error end
	NX_WriteObj_instance	NX_WriteObj		
	NX_SaveParam_instance	NX_SaveParam		
	R_Trig_Instance	R_TRIG		

External Variables	Variable	Constant	Data type	Comment
	_EC_MBXSlavTbl	✓	ARRAY[1..512] OF BOOL *1	Message Communications Enabled Slave Table

*1 The data type is ARRAY [1..192] OF BOOL for an NJ-series CPU Unit.

```

// Prepare object parameter and write data.
R_Trig_instance(Clk := Trigger);
IF (R_Trig_instance.Q=TRUE) THEN
  NXObject.Index := UINT#16#5004;
  NXObject.Subindex := USINT#1;
  VarWriteData := UINT#2;
END_IF;

// Execute NX_WriteObj instruction.
IF (Trigger=TRUE) THEN
  WriteCondition := TRUE;
END_IF;

IF ((NX_WriteObj_instance.Done=TRUE) OR (NX_WriteObj_instance.Error=TRUE)) THEN
  WriteCondition := FALSE;
END_IF;

WriteGo := WriteCondition & _EC_MBXSlavTbl[10];
NX_WriteObj_instance(
  Execute := WriteGo,
  UnitProxy := NXUnitProxy,
  Obj := NXObject,
  TimeOut := UINT#2000,
  WriteDat := VarWriteData);

// Execute NX_SaveParam instruction.
IF (NX_WriteObj_instance.Done=TRUE) THEN
  SaveCondition := TRUE;
END_IF;

IF ((NX_SaveParam_instance.Done=TRUE) OR (NX_SaveParam_instance.Error=TRUE)) THEN

```

```
    SaveCondition := FALSE;
END_IF;

SaveGo := SaveCondition & _EC_MBXSlavTbl[10];
NX_SaveParam_instance(
    Execute      := SaveGo,
    UnitProxy   := NXUnitProxy,
    TimeOut     := UINT#2000);

IF (NX_SaveParam_instance.Done=TRUE) THEN
    // Processing after normal end.
    NormalEnd := NormalEnd + UINT#1;
ELSIF ((NX_WriteObj_instance.Error=TRUE) OR (NX_SaveParam_instance.Error=TRUE))
THEN
    // Processing after error end.
    ErrorEnd := ErrorEnd + UINT#1;
END_IF;
```

NX_ReadObj

The NX_ReadObj instruction reads data from an NX object in an EtherCAT Coupler Unit or NX Unit.

Instruction	Name	FB/FUN	Graphic expression	ST expression
NX_ReadObj	Read NX Unit Object	FB		NX_ReadObj_instance(Execute, UnitProxy, Obj, TimeOut, ReadDat, Done, Busy, Error, ErrorID, ErrorIDEx);

Variables

Name	Meaning	I/O	Description	Valid range	Unit	Default
UnitProxy	Specified Unit	Input	Unit from which to read data	---	---	*
Obj	Object parameter		Object parameter			---
TimeOut	Timeout time		Timeout time If 0 is set, the timeout time is 2.0 s.			0 to 60,000
ReadDat	Read data	In-out	Data read from NX object	Depends on data type.	---	---

* If you omit the input parameter, the default value is not applied. A building error will occur.

	Boolean	Bit strings					Integers							Real numbers	Times, durations, dates, and text strings					
	BOOL	BYTE	WORD	DWORD	LWORD	USINT	UINT	UDINT	ULINT	SINT	INT	DINT	LINT	REAL	LREAL	TIME	DATE	TOD	DT	STRING
UnitProxy	Refer to <i>Function</i> for details on the structure <code>_sNXUNIT_ID</code> .																			
Obj	Refer to <i>Function</i> for details on the structure <code>_sNXOBJ_ACCESS</code> .																			
TimeOut							OK													
ReadDat	OK	OK	OK	OK	OK	OK	OK	OK	OK	OK	OK	OK	OK	OK	OK	OK	OK	OK	OK	OK
	An array can also be specified.																			

Function

The NX_ReadObj instruction reads data from an NX object in an EtherCAT Coupler Unit, an NX Unit on the EtherCAT Coupler Unit, or an NX Unit connected to the NX bus of the CPU Unit and stores the data in *ReadDat*. The Unit from which the data is read is specified with *UnitProxy*.

TimeOut specifies the timeout time. If a response does not return within the timeout time, it is assumed that communications failed. In that case, the data is not read.

The data type of *UnitProxy* is structure `_sNXUNIT_ID`. The meanings of the members are as follows:

Name	Meaning	Content	Data type
UnitProxy	Specified Unit	Specified Unit	<code>_sNXUNIT_ID</code>
NodeAdr	Node address	Node address of the Communications Coupler Unit	UINT
IPAdr	IP address	IP address of the Communications Coupler Unit	BYTE[5]
UnitNo	Unit number	Unit number of specified Unit	UDINT
Path	Path	Path information to the specified Unit	BYTE[64]
PathLength	Valid path length	Valid path length	USINT

Pass the device variable that is assigned to the specified Unit to *UnitProxy*.

The data type of *Obj* is structure `_sNXOBJ_ACCESS`. The meanings of the members are as follows:

Name	Meaning	Content	Data type	Valid range	Unit	Default
Obj	Object parameter	Object parameter	<code>_sNXOBJ_ACCESS</code>	---	---	---
Index	Index	Index	UINT	Depends on data type.	---	0
Subindex	Subindex	Subindex	USINT			
IsCompleteAccess*1	Complete access	Complete access	BOOL	FALSE only		FALSE

*1 This member is not used for this instruction. Always set the value to FALSE.

Notation Example

The following notation example shows how to read the unit version from an NX-ID4342 Digital Input Unit.

The read data is stored in *Rdat*, which is a UDINT variable.

A variable that is named 'NX1' with a data type of `_sNXUNIT_ID` is assigned to the Unit from which to read the data.

For the NX-ID4342, the index of the Unit version is `UINT#16#1000` and the subindex is `USINT#6`.

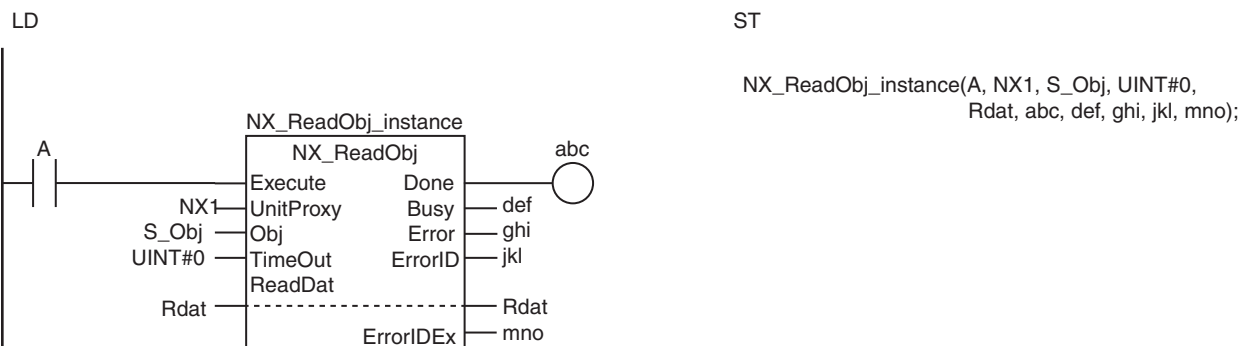

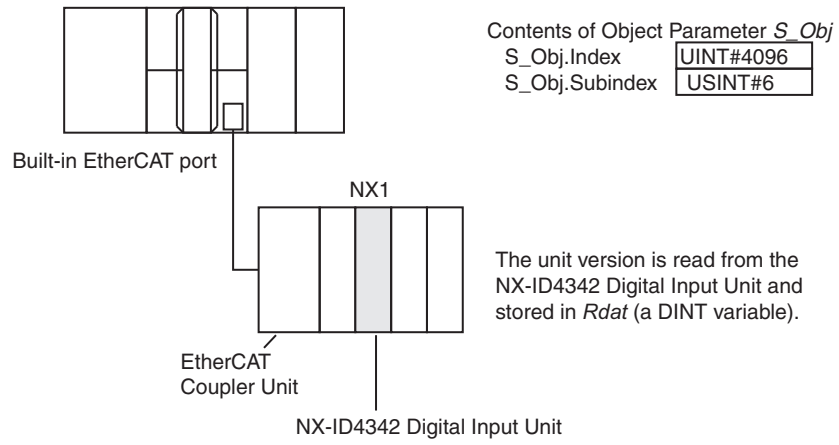

Related System-defined Variables

Variable	Name	Data type	Description
_EC_MBXSlavTbl[i] “i” is the node address.	Message Communications Enabled Slave Table	BOOL	This variable indicates whether communications are possible for each slave. TRUE: Communications are possible. FALSE: Communications are not possible.
_NXB_UnitMsgActiveTbl[i]	NX Unit Message Enabled Status	BOOL	This table indicates the slaves that can perform message communications. Use this variable to confirm that communications with the relevant slave are possible.

Precautions for Correct Use

- Execution of this instruction is continued until processing is completed even if the value of *Execute* changes to FALSE or the execution time exceeds the task period. The value of *Done* changes to TRUE when processing is completed. Use this to confirm normal completion of processing.
- Refer to *Using this Section* (page 2-3) for a timing chart for *Execute*, *Done*, *Busy*, and *Error*.
- If *ReadDat* is an array, make sure that the overall size of the array is the same as the size of the NX object to read in the specified Unit
- For *UnitProxy*, specify the device variable that is assigned to an EtherCAT Coupler Unit, an NX Unit on the EtherCAT Coupler Unit, or an NX Unit connected to the NX bus of the CPU Unit in the I/O Map of the Sysmac Studio. Refer to the *Sysmac Studio Version 1 Operation Manual* (Cat. No. W504-E1-07 or later) for details on assigning device variables.
- This instruction is related to NX Message Communications Errors. If too many instructions that are related to NX Message Communications Errors are executed at the same time, an NX Message Communications Error will occur. Refer to Instructions Related to NX Message Communications Errors (page A-214) for a list of the instructions that are related to NX Message Communications Errors.

- *Error* is TRUE if an error occurred. The meanings of the values of *ErrorID* and *ErrorIDEx* are given in the following table.

Value of <i>ErrorID</i>	Value of <i>ErrorIDEx</i>	Meaning
16#0400	16#00000000	<ul style="list-style-type: none"> • The value of <i>UnitProxy</i> is outside of the valid range. • The value of <i>TimeOut</i> is outside of the valid range.
16#0410	16#00000000	<i>ReadDat</i> is STRING data and it does not end in a NULL character.
16#0419	16#00000000	<ul style="list-style-type: none"> • The data type of <i>UnitProxy</i> is not correct. • The data type of <i>ReadDat</i> is not correct.
16#041C	16#00000000	The size of <i>ReadDat</i> is not the same as the size of the NX object to read.
16#2C00	16#00000401	The specified Unit does not support the instruction.
	16#00001001 16#00001002 16#00170000 16#00200000 16#00210000	An input parameter, output parameter, or in-out parameter is incorrect. Confirm that the intended parameter is used for the input parameter, output parameter, or in-out parameter.
	16#00001010	The data size of the specified NX object does not agree with the data size specified in <i>WriteDat</i> .
	16#00001101	The correct Unit was not specified. Check the Unit.
	16#0000110B	The size of the read data is too large. Make sure that the read data specification is correct.
	16#00001110	There is no object that corresponds to the value of <i>Obj.Index</i> .
	16#00001111	There is no object that corresponds to the value of <i>Obj.Subindex</i> .
	16#00002101	The specified NX object cannot be written.
	16#00002110	The value of <i>WriteDat</i> exceeds the range of the values of the NX object to write.
	16#00002210	The specified Unit is not in a mode that allows writing data.
	16#00002213	Instruction execution was not possible because the specified Unit was performing an I/O check. Execute the instruction after the I/O check is completed.
	16#00002230	The status of the specified Unit does not agree with the value of the read source or write destination NX object. Take the following actions if the value of <i>Obj.Index</i> is between 0x6000 and 0x6FFF or between 0x7000 and 0x7FFF. <ul style="list-style-type: none"> • Delete the read source or write designation NX object from the I/O allocation settings. • Reset the error for the specified Unit. • Place the specified Unit in a mode that does not allow writing data.
	16#00002231	Instruction execution was not possible because the specified Unit was performing initialization. Wait for the Unit to start normal operation and then execute the instruction.
	16#0000250F	Hardware access failed. Execute the instruction again.
	16#00002601 16#00002602 16#00100000	The specified Unit does not support this instruction. Check the version of the Unit.
	16#00002603	Execution of the instruction failed. Execute the instruction again. Make sure that at least one channel is enabled in the selections of the channels to use.
	16#00002621	The NX Unit is not in a status in which it can acknowledge the instruction. Wait for a while and then execute the instruction again.
16#00010000	The specified Unit does not exist. Make sure that the Unit configuration is correct.	

Value of <i>ErrorID</i>	Value of <i>ErrorIDEx</i>	Meaning	
16#2C00	16#00110000	The specified port number does not exist. Make sure that the Unit configuration is correct.	
	16#00120000 16#00130000 16#00150000 16#00160000	The value of <i>UnitProxy</i> is not correct. Set the variable that indicates the specified EtherCAT Coupler Unit again.	
	16#00140000	The specified node address is not correct. Make sure that the Unit configuration is correct.	
	16#00300000 16#80010000	The specified Unit is busy. Execute the instruction again.	
	16#00310000	The specified Unit is not supported for connection. Check the version of the Unit.	
	16#80000000 16#80050000 16#81010000 16#81020000 16#82020000 16#82030000 16#82060000 to 16#8FFF0000 16#90010000 to 16#FFFE0000	An error occurred in the communications network. Execute the instruction again.	
	16#80020000 16#80030000 16#81030000 16#82000000	An error occurred in the communications network. Reduce the amount of communications traffic.	
	16#80040000 16#81000000 16#82010000 16#82040000 16#82050000 16#90000000	An error occurred in the communications network. Check the Unit and cable connections. Make sure that the power supply to the Unit is ON.	
	16#2C01	16#00000000	The number of instructions that can be simultaneously executed was exceeded.
	16#2C02	16#00000000	A timeout occurred during communications.



Version Information

A CPU Unit with unit version 1.05 or later and Sysmac Studio version 1.06 or higher are required to use this instruction.

Sample Programming

This sample reads the value of the I/O Refresh Method 1 object parameter from an NX-ECC201 EtherCAT Coupler Unit.

The node address of the EtherCAT Coupler Unit is 10.

The values of the index and subindex of the I/O Refresh Method 1 object parameter are as follows:

Item	Value
Index	16#4002
Subindex	16#01

LD

Internal Variables	Variable	Data type	Initial value	Comment
	Trigger	BOOL	FALSE	Execution condition
	ReadCondition	BOOL	FALSE	Execution condition to read data
	NXUnitProxy	_sNXUNIT_ID		Unit designation
	NXObject	_sNXOBJ_ACCESS	(Index:=0, Subindex:=0, IsCompleteAccess:=FALSE)	Object parameter
	IoRefreshMethod	USINT	0	Read data
	NX_ReadObj_instance	NX_ReadObj		

External Variables	Variable	Constant	Data type	Comment
	_EC_MBXSlavTbl	✓	ARRAY[1..512] OF BOOL *1	Message Communications Enabled Slave Table

*1 The data type is ARRAY [1..192] OF BOOL for an NJ-series CPU Unit.

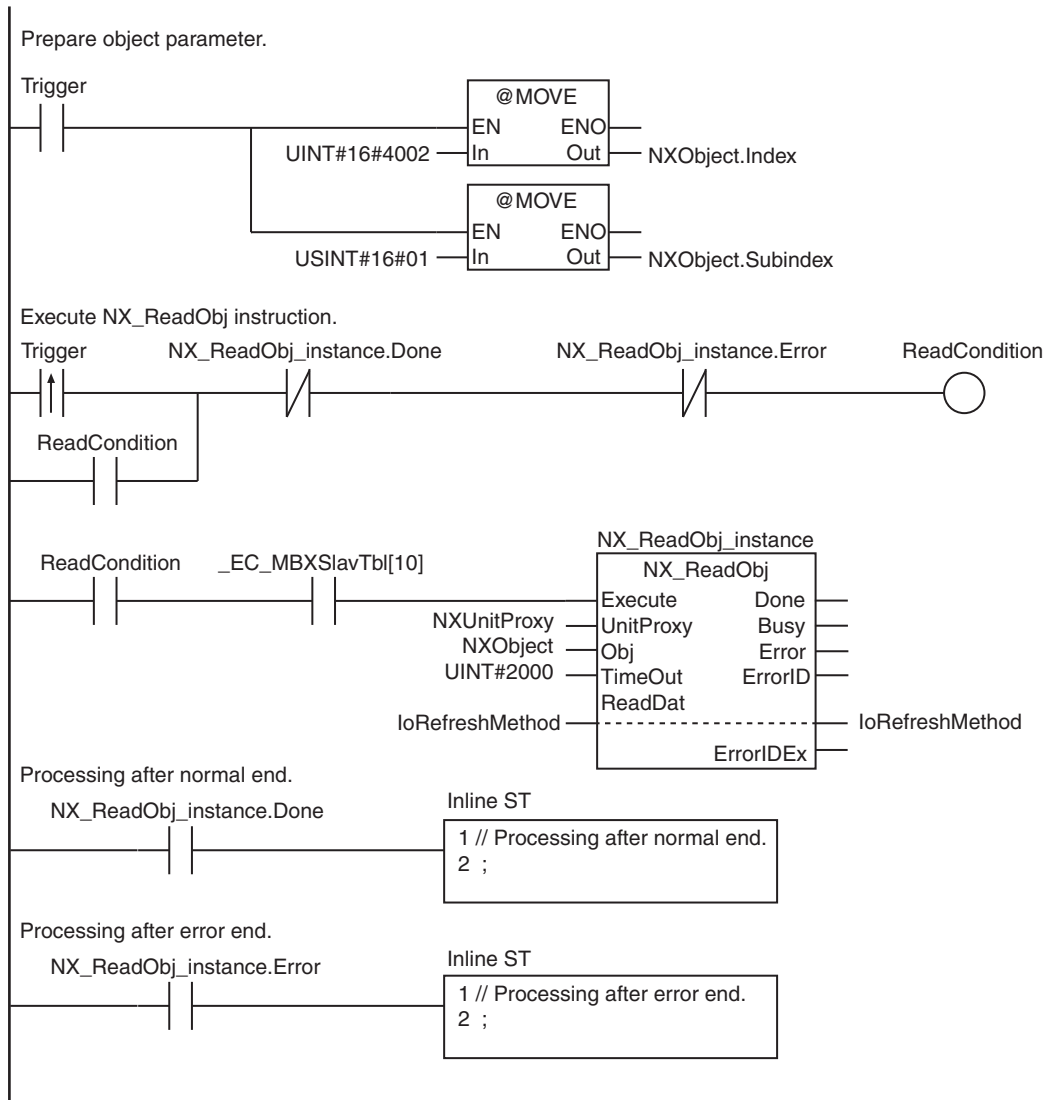

ST

Internal Variables	Variable	Data type	Initial value	Comment
	Trigger	BOOL	FALSE	Execution condition
	ReadCondition	BOOL	FALSE	Execution condition to read data
	ReadGo	BOOL	FALSE	Execution of data read
	NXUnitProxy	_sNXUNIT_ID		Unit designation
	NXObject	_sNXOBJ_ACCESS	(Index:=0, Subindex:=0, IsCompleteAccess:=FALSE)	Object parameter
	IoRefreshMethod	USINT	0	Read data
	NormalEnd	UINT	0	Normal end
	ErrorEnd	UINT	0	Error end
	R_Trig_instance	R_Trig		
	NX_ReadObj_instance	NX_ReadObj		

External Variables	Variable	Constant	Data type	Comment
	_EC_MBXSlavTbl	✓	ARRAY[1..512] OF BOOL *1	Message Communications Enabled Slave Table

*1 The data type is ARRAY [1..192] OF BOOL for an NJ-series CPU Unit.

```

// Prepare object parameter.
R_Trig_instance(Clk := Trigger);
IF (R_Trig_instance.Q=TRUE) THEN
    NXObject.Index := UINT#16#4002;
    NXObject.Subindex := USINT#1;
END_IF;

// Execute NX_ReadObj instruction.
IF (Trigger=TRUE) THEN
    ReadCondition := TRUE;
END_IF;

IF ( (NX_ReadObj_instance.Done=TRUE) OR (NX_ReadObj_instance.Error=TRUE) ) THEN
    ReadCondition := FALSE;
END_IF;

ReadGo := ReadCondition & _EC_MBXSlavTbl[10];
NX_ReadObj_instance(
    Execute := ReadGo,
    UnitProxy := NXUnitProxy,
    Obj := NXObject,
    TimeOut := UINT#2000,
    ReadDat := IoRefreshMethod);

// Processing after instruction execution.
IF (NX_ReadObj_instance.Done=TRUE) THEN
    // Processing after normal end.
    NormalEnd := NormalEnd + UINT#1;
ELSIF (NX_ReadObj_instance.Error=TRUE) THEN
    // Processing after error end.
    ErrorEnd := ErrorEnd + UINT#1;
END_IF;

```

IO-Link Communications Instruction

Instruction	Name	Page
IOL_ReadObj	Read IO-Link Device Object	2-998
IOL_WriteObj	Write IO-Link Device Object	2-1007

IOL_ReadObj

The IOL_ReadObj instruction reads data from IO-Link device objects.

Instruction	Name	FB/ FUN	Graphic expression	ST expression
IOL_ReadObj	Read IO-Link Device Object	FB		<pre>IOL_ReadObj_instance(Execute, DevicePort, DeviceObj, RetryCfg, ReadDat, Done, Busy, Error, ErrorID, ErrorType, ReadSize);</pre>



Version Information

A CPU Unit with unit version 1.12 or later and Sysmac Studio version 1.16 or higher are required to use this instruction.

Variables

	Meaning	I/O	Description	Valid range	Unit	Default
DevicePort	Device port	Input	Object that represents a device port	---	---	---
DeviceObj	IO-Link device object parameter		Specification for the IO-Link device object	---	---	---
RetryCfg	Execution retry setting		Setting for the instruction execution retry	---	---	---
ReadDat	Read data	In-out	Data read from IO-Link device	Depends on data type.	---	0
ErrorType	Error type	Output	Error code that is returned by IO-Link device is stored when <i>ErrorID</i> is 4800 hex.	16#0000 to 16#FFFF	---	---
ReadSize	Read data size		Size of data stored in <i>ReadDat</i>	10#1 to 10#232	Bytes	---

	Boolean	Bit strings				Integers							Real numbers		Times, durations, dates, and text strings					
	BOOL	BYTE	WORD	DWORD	LWORD	USINT	UINT	UDINT	ULINT	SINT	INT	DINT	LINT	REAL	LREAL	TIME	DATE	TOD	DT	STRING
DevicePort	Refer to <i>Function</i> for details on the structure <code>_sDEVICE_PORT</code> .																			
DeviceObj	Refer to <i>Function</i> for details on the structure <code>_sIOLOBJ_ACCESS</code> .																			
RetryCfg	Refer to <i>Function</i> for details on the structure <code>_sIOL_RETRY_CFG</code> .																			
ReadDat	OK	OK	OK	OK	OK	OK	OK	OK	OK	OK	OK	OK	OK	OK	OK	OK	OK	OK	OK	OK
	An array can also be specified.																			
ErrorType			OK																	
ReadSize							OK													

Function

The IOL_ReadObj instruction reads object data from IO-Link devices.

For the *DevicePort* input variable, set the IO-Link master unit and the port number to which the target IO-Link device for reading is connected.

The data type of the *DevicePort* input variable is structure `_sDEVICE_PORT`. The specifications are as follows:

Name	Meaning	Description	Data type	Valid range	Unit	Default
DevicePort	Device port	Object that represents a device port	<code>_sDEVICE_PORT</code>	---	---	---
DeviceType	Device type	Type of the device to specify	<code>_eDEVICE_TYPE</code>	<code>_DeviceNXUnit</code> <code>_DeviceEcatSlave</code> <code>_DeviceOptionBoard</code>	---	---
NxUnit	Specified Unit	NX Unit to control	<code>_sNXUNIT_ID</code>	---	---	---
EcatSlave	Specified slave	EtherCAT slave to control	<code>_sECAT_ID</code>	---	---	---
OptBoard	Specified Option Board	Option Board to control	<code>_sOPTBOARD_ID</code>	---	---	---
Reserved	Reserved	Reserved	---	---	---	---
PortNo	Port number	Port number 1: Port 1 2: Port 2 3: Port 3 4: Port 4 5: Port 5 6: Port 6 7: Port 7 8: Port 8	USINT	Depends on data type.	---	---

Use *DeviceType* to specify the device type. Specify *_DeviceNXUnit* for an NX type of IO-Link master unit and *_DeviceEcatSlave* for a GX type of IO-Link master unit. The variable used to specify the device is determined by the specified device type.

For this instruction, it is determined as follows:

To specify the NX type, use *NxUnit* to specify the device. In this case, *EcatSlave* is not used. To *NxUnit*, pass the device variable that is assigned to the device to specify.

To specify the GX type, use *EcatSlave* to specify the device. In this case, *NxUnit* is not used. To *EcatSlave*, pass the device variable that is assigned to the device to specify.

Use *PortNo* to set the port number to which the IO-Link device is connected.

The number of ports differs depending on the type of IO-Link master unit.

NX type: 1 to 4

GX type: 1 to 8

The data type of *DeviceType* is enumerated type *_eDEVICE_TYPE*.

The meanings of the enumerators of enumerated type *_eDEVICE_TYPE* are as follows:

Enumerator	Meaning
<i>_DeviceNXUnit</i>	NX Unit is specified.
<i>_DeviceEcatSlave</i>	EtherCAT slave is specified.

Use the *DeviceObj* input variable to specify the object parameter for the IO-Link device from which data is read.

The data type of the *DeviceObj* input variable is structure *_sIOLOBJ_ACCESS*. The specifications are as follows:

Name	Meaning	Description	Data type	Valid range	Unit	Default
<i>DeviceObj</i>	IO-Link device object parameter	Specification for the IO-Link device object	<i>_sIOLOBJ_ACCESS</i>	---	---	---
Index	Index	Index	UINT	Depends on data type.	---	---
Subindex	Subindex	Set 0 to read from the entire index.	USINT	Depends on data type.	---	---

Use the *RetryCfg* input variable to set retry processing for instruction execution.

The data type of *RetryCfg* is structure *_sIOL_RETRY_CFG*. The specifications are as follows:

Name	Meaning	Description	Data type	Valid range	Unit	Default
<i>RetryCfg</i>	Execution retry setting	Setting for the instruction execution retry	<i>_sIOL_RETRY_CFG</i>	---	---	---
TimeOut	Timeout time	2.0 s when the timeout time is set to 0	TIME	0 to 300 s	---	T#2.0s
RetryNum	Number of retries	3 times if the number of retries at timeout is set to 0	UINT	Depends on data type.	Times	3

Data read from the IO-Link device is stored in the *ReadDat* in-out variable.

Timing Charts

The following figures show the timing charts.

● Normal end

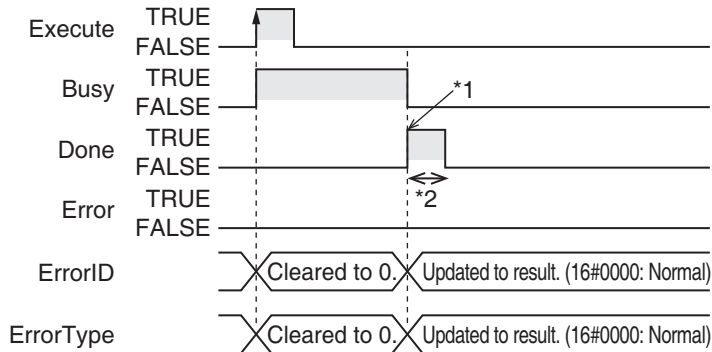

*1 Reading completed.

*2 Task period

● Error end

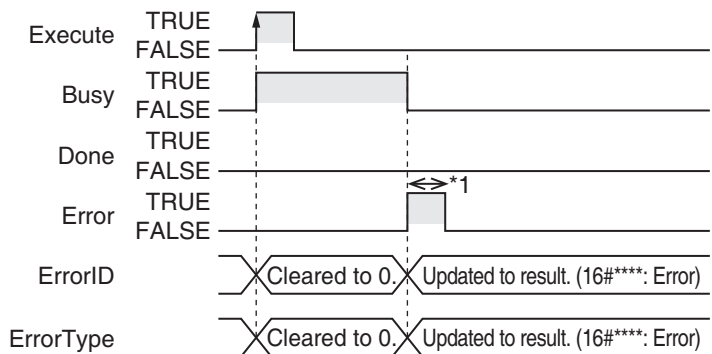

*1 Task period

Related System-defined Variables

Name	Meaning	Data type	Description
_EC_MBXSlavTbl	Message Communications Enabled Slave Table	ARRAY[1..512] OF BOOL*1	This table indicates the slaves that can perform message communications. Slaves are given in the table in the order of slave node addresses. TRUE: Communications are possible. FALSE: Communications are not possible.

*1 The data type is ARRAY [1..192] OF BOOL for an NJ-series CPU Unit.

Precautions for Correct Use

- Execution of this instruction is continued until processing is completed even if the value of *Execute* changes to FALSE or the execution time exceeds the task period. The value of *Done* changes to TRUE when processing is completed. Use this to confirm normal completion of processing.
- For *DevicePort.NxUnit* and *DevicePort.EcatSlave*, specify the device variable that is assigned to the IO-Link master unit in the I/O Map of the Sysmac Studio. Refer to the *Sysmac Studio Version 1 Operation Manual* (Cat. No. W504-E1-07 or later) for details on assigning device variables.
- The size of the variable specified for *ReadDat* must be larger than the size of the object that is actually read.
- If *ReadDat* is STRING data, specify a variable whose size is the sum of the actually read string and a NULL character.
- If *ReadDat* is STRING data, the size that is output to *ReadSize* does not include the NULL character.
- Always use a variable for the parameter to pass to *ReadDat*. A building error will occur if a constant is passed.
- You can execute only one instruction at a time for the IO-Link master unit regardless of its type (NX or GX).
- You cannot use this instruction in an event task. A compiling error will occur.
- This instruction is executed when *Execute* changes to TRUE. The instruction is not executed when *Execute* is always TRUE.
- You can use a maximum of 64 instances for the IOL_ReadObj and IOL_WriteObj instructions.
- An error will occur in the following cases.
 - A value that is out of range was set for *DevicePort.NxUnit* or *DevicePort.EcatSlave*.
 - The size of the IO-Link device object to read is larger than the size of *ReadDat*. If this error occurs, the read data is not stored in *ReadDat*.
 - An error response was received from the IO-Link device.
The upper eight bits represent *ErrorCode*, and lower eight bits represent *AdditionalCode*.
For *ErrorCode* and *AdditionalCode*, refer to the Error type specifications of the IO-Link Communication Specification. You can obtain the Error type specifications from the IO-Link Consortium.
<http://www.io-link.com/>
 - The specified IO-Link master unit does not exist.
 - The maximum number of messages that the IO-Link master can process is exceeded. Instruction execution is not possible because the IO-Link master is processing the messages from other applications.
 - The specified IO-Link master unit is not in a condition to receive messages.
 - More than 32 of the following instructions were executed at the same time: EC_CoESDOWrite, EC_CoESDORead, EC_StartMon, EC_StopMon, EC_SaveMon, EC_CopyMon, EC_DisconnectSlave, EC_ConnectSlave, EC_ChangeEnableSetting, IOL_ReadObj, and IOL_WriteObj.
 - A timeout occurred during communications.
 - The specified port of the IO-Link master unit is not the IO-Link mode. The port is disabled or in the SIO mode.
 - The IO-Link device is not connected to the specified port on the IO-Link master unit.
 - The IO power is not supplied to the specified port of the IO-Link master unit.
 - The specified port of the IO-Link master unit had a verification error or communications error.

Sample Programming

In this sample, an IO-Link master unit (NX-ILM400) is connected to an EtherCAT Coupler Unit (NX-ECC203).

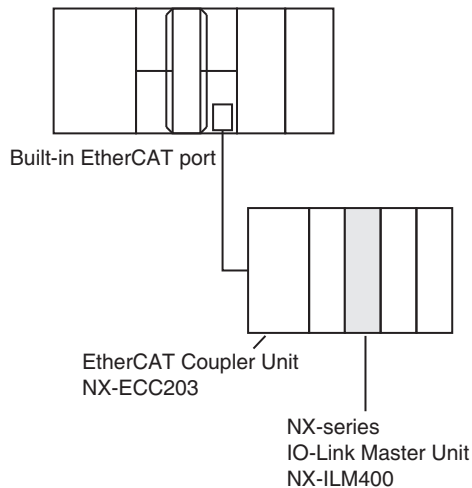

The error log (Index:37/Subindex:0) of 30 bytes is read from the photoelectric sensor (E3Z) connected to port 1 on the NX-ILM400. The read data is stored in *DeviceErrorLog*.

The node address of the NX-ECC203 is 10.

LD

Internal Variables	Variable	Data type	Initial value	Comment
	Trigger	BOOL	FALSE	Execution condition
	ReadCondition	BOOL	FALSE	Data reading execution condition
	DevicePort	_sDEVICE_PORT		
	DeviceObject	_sIOLOBJ_ACCESS	(Index:=0, Sub-index:=0)	Specification for the IO-Link device object
	DeviceErrorLog	ARRAY[1..30] OF BYTE		Read data
	IOL_ReadObj_instance	IOL_ReadObj		

External Variables	Variable	Constant	Initial value	Comment
	_EC_MBXSlaVtbl	<input checked="" type="checkbox"/>	ARRAY[1..512] OF BOOL*1	Message Communications Enabled Slave Table
	IO_LINK_Unit	<input checked="" type="checkbox"/>	Set the device variable which specifies NX-ILM400 as the initial value of the structure member <i>NxUnit</i> .	

*1 For NJ-series CPU Units, the data type is ARRAY [1..192] OF BOOL.

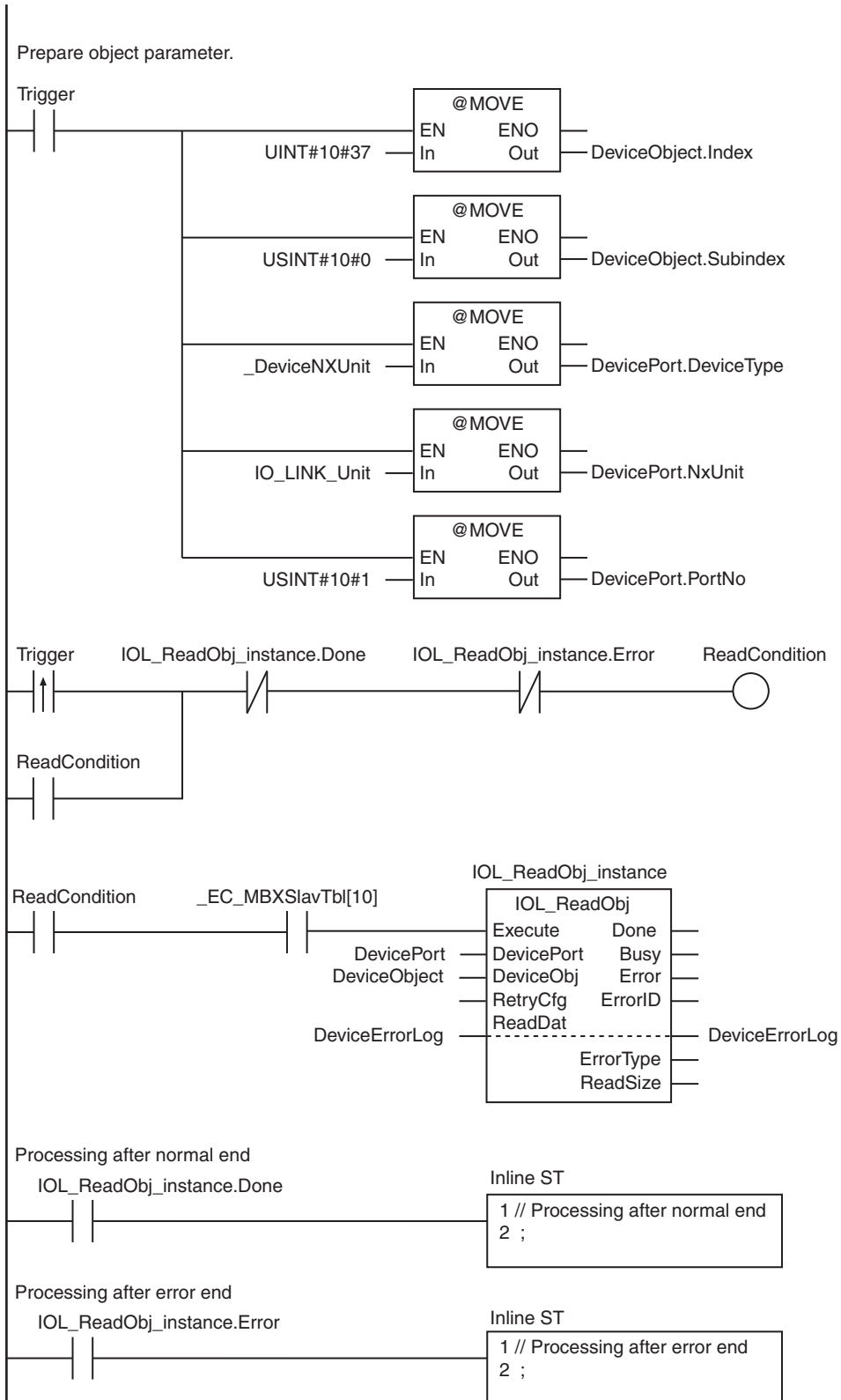

ST

Internal Variables	Variable	Data type	Initial value	Comment
	Trigger	BOOL	FALSE	Execution condition
	ReadGo	BOOL	FALSE	Data reading execution
	DevicePort	_sDEVICE_PORT		
	DeviceObject	_sIOLOBJ_ACCESS	(Index:=0, Sub-index:=0)	Specification for the IO-Link device object
	DeviceErrorLog	ARRAY[1..30] OF BYTE		Read data
	NormalEnd	UINT	0	Normal end
	ErrorEnd	UINT	0	Error end
	R_Trig_instance	R_Trig		
	IOL_ReadObj_instance	IOL_ReadObj		

External Variables	Variable	Constant	Initial value	Comment
	_EC_MBXSlavTbl	<input checked="" type="checkbox"/>	ARRAY[1..512] OF BOOL*1	Message Communications Enabled Slave Table
	IO_LINK_Unit	<input checked="" type="checkbox"/>	Set the device variable which specifies NX-ILM400 as the initial value of the structure member <i>NxUnit</i> .	

*1 For NJ-series CPU Units, the data type is ARRAY [1..192] OF BOOL.

```
// Prepare object parameter.
R_Trig_instance(Clk := Trigger);
IF (R_Trig_instance.Q=TRUE) THEN
    DeviceObject.Index := UINT#10#37;
    DeviceObject.Subindex := USINT#0;
    DevicePort.DeviceType := _eDEVICE_TYPE#_DeviceNXUnit;
    DevicePort.NxUnit := IO_LINK_Unit;
    DevicePort.PortNo := USINT#10#1;
    IF ( _EC_MBXSlavTbl[10] =TRUE) THEN
        ReadGo := TRUE;
    END_IF;
END_IF;

IF ( (IOL_ReadObj_instance.Done=TRUE) OR (IOL_ReadObj_instance.Error=TRUE) ) THEN
    ReadGo := FALSE;
END_IF;

// Execute IOL_ReadObj instruction.
IOL_ReadObj_instance(
    Execute := ReadGo,
    DevicePort := DevicePort,
    DeviceObj := DeviceObject,
    ReadDat := DeviceErrorLog);

// Processing after instruction execution
IF (IOL_ReadObj_instance.Done=TRUE) THEN
    // Processing after normal end
    NormalEnd := NormalEnd + UINT#1;
ELSIF (IOL_ReadObj_instance.Error=TRUE) THEN
```

```
    // Processing after error end  
    ErrorEnd := ErrorEnd + UINT#1;  
END_IF;
```

IOL_WriteObj

The IOL_WriteObj instruction writes data to IO-Link device objects.

Instruction	Name	FB/ FUN	Graphic expression	ST expression
IOL_WriteObj	Write IO-Link Device Object	FB		<pre>IOL_WriteObj_instance(Execute, DevicePort, DeviceObj, RetryCfg, WriteDat, WriteSize, Done, Busy, Error, ErrorID, ErrorType);</pre>



Version Information

A CPU Unit with unit version 1.12 or later and Sysmac Studio version 1.16 or higher are required to use this instruction.

Variables

	Meaning	I/O	Description	Valid range	Unit	Default
DevicePort	Device port	Input	Object that represents a device port	---	---	---
DeviceObj	IO-Link device object parameter		Specification for the IO-Link device object	---	---	---
RetryCfg	Execution retry setting		Setting for the instruction execution retry	---	---	---
WriteDat	Write data		Data written to IO-Link device	Depends on data type.	---	---
WriteSize	Write data size		Write data size*1	10#1 to 10#232	Bytes	---
ErrorType	Error type	Output	Error code that is returned by IO-Link device is stored when <i>ErrorID</i> is 4800 hex.	16#0000 to 16#FFFF	---	---

*1 Input 1 if the written data is a BOOL data. Input the number of elements if the written data is a BOOL array.

	Boolean	Bit strings					Integers							Real numbers	Times, durations, dates, and text strings					
	BOOL	BYTE	WORD	DWORD	LWORD	USINT	UINT	UDINT	ULINT	SINT	INT	DINT	LINT	REAL	LREAL	TIME	DATE	TOD	DT	STRING
DevicePort	Refer to <i>Function</i> for details on the structure <code>_sDEVICE_PORT</code> .																			
DeviceObj	Refer to <i>Function</i> for details on the structure <code>_sIOLOBJ_ACCESS</code> .																			
RetryCfg	Refer to <i>Function</i> for details on the structure <code>_sIOL_RETRY_CFG</code> .																			
WriteDat	OK	OK	OK	OK	OK	OK	OK	OK	OK	OK	OK	OK	OK	OK	OK	OK	OK	OK	OK	OK
	An array can also be specified.																			
WriteSize							OK													
ErrorType			OK																	

Function

The `IOL_WriteObj` instruction writes object data to IO-Link devices.

For the *DevicePort* input variable, set the IO-Link master unit and the port number to which the target IO-Link device for writing is connected.

The data type of the *DevicePort* input variable is structure `_sDEVICE_PORT`. The specifications are as follows:

Name	Meaning	Description	Data type	Valid range	Unit	Default
DevicePort	Device port	Object that represents a device port	<code>_sDEVICE_PORT</code>	---	---	---
DeviceType	Device type	Type of the device to specify	<code>_eDEVICE_TYPE</code>	<code>_DeviceNXUnit</code> <code>_DeviceEcatSlave</code> <code>_DeviceOptionBoard</code>	---	---
NxUnit	Specified Unit	NX Unit to control	<code>_sNXUNIT_ID</code>	---	---	---
EcatSlave	Specified slave	EtherCAT slave to control	<code>_sECAT_ID</code>	---	---	---
OptBoard	Specified Option Board	Option Board to control	<code>_sOPTBOARD_ID</code>	---	---	---
Reserved	Reserved	Reserved	---	---	---	---
PortNo	Port number	Port number 1: Port 1 2: Port 2 3: Port 3 4: Port 4 5: Port 5 6: Port 6 7: Port 7 8: Port 8	USINT	Depends on data type.	---	---

Use *DeviceType* to specify the device type. Specify *_DeviceNXUnit* for an NX type of IO-Link master unit and *_DeviceEcatSlave* for a GX type of IO-Link master unit. The variable used to specify the device is determined by the specified device type.

For this instruction, it is determined as follows:

To specify the NX type, use *NxUnit* to specify the device. In this case, *EcatSlave* is not used. To *NxUnit*, pass the device variable that is assigned to the device to specify.

To specify the GX type, use *EcatSlave* to specify the device. In this case, *NxUnit* is not used. To *EcatSlave*, pass the device variable that is assigned to the device to specify.

Use *PortNo* to set the port number to which the IO-Link device is connected.

The number of ports differs depending on the type of IO-Link master unit.

NX type: 1 to 4

GX type: 1 to 8

The data type of *DeviceType* is enumerated type *_eDEVICE_TYPE*.

The meanings of the enumerators of enumerated type *_eDEVICE_TYPE* are as follows:

Enumerator	Meaning
<i>_DeviceNXUnit</i>	NX Unit is specified.
<i>_DeviceEcatSlave</i>	EtherCAT slave is specified.

Use the *DeviceObj* input variable to specify the object parameter for the IO-Link device to which data is written. The data type of the *DeviceObj* input variable is structure *_sIOLOBJ_ACCESS*. The specifications are as follows:

Name	Meaning	Description	Data type	Valid range	Unit	Default
DeviceObj	IO-Link device object parameter	Specification for the IO-Link device object	<i>_sIOLOBJ_ACCESS</i>	---	---	---
Index	Index	Index	UINT	Depends on data type.	---	---
Subindex	Subindex	Set 0 to read from the entire index.	USINT	Depends on data type.	---	---

Use the *RetryCfg* input variable to set retry processing for instruction execution.

The data type of *RetryCfg* is structure *_sIOL_RETRY_CFG*. The specifications are as follows:

Name	Meaning	Description	Data type	Valid range	Unit	Default
RetryCfg	Execution retry setting	Setting for the instruction execution retry	<i>_sIOL_RETRY_CFG</i>	---	---	---
TimeOut	Timeout time	2.0 s when the timeout time is set to 0	TIME	0 to 300 s	---	T#2.0s
RetryNum	Number of retries	3 times if the number of retries at timeout is set to 0	UINT	Depends on data type.	Times	3

Use the *WriteDat* input variable to specify the data to write to the IO-Link device.

Timing Charts

The following figures show the timing charts.

● Normal end

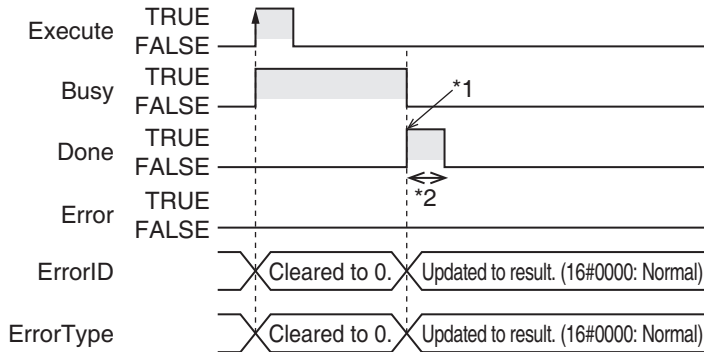

*1 Writing completed.

*2 Task period

● Error end

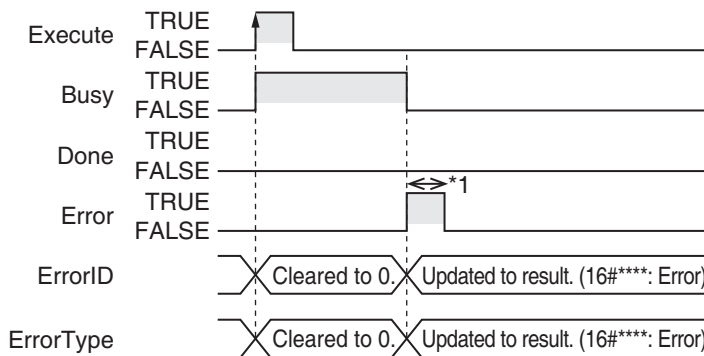

*1 Task period

Related System-defined Variables

Name	Name	Data type	Description
_EC_MBXSlavTbl	Message Communications Enabled Slave Table	ARRAY[1..512] OF BOOL *1	<p>This table indicates the slaves that can perform message communications.</p> <p>Slaves are given in the table in the order of slave node addresses.</p> <p>TRUE: Communications are possible.</p> <p>FALSE: Communications are not possible.</p>

*1 The data type is ARRAY [1..192] OF BOOL for an NJ-series CPU Unit.

Precautions for Correct Use

- Execution of this instruction is continued until processing is completed even if the value of *Execute* changes to FALSE or the execution time exceeds the task period. The value of *Done* changes to TRUE when processing is completed. Use this to confirm normal completion of processing.
- For *DevicePort.NxUnit* and *DevicePort.EcatSlave*, specify the device variable that is assigned to the IO-Link master unit in the I/O Map of the Sysmac Studio. Refer to the *Sysmac Studio Version 1 Operation Manual* (Cat. No. W504-E1-07 or later) for details on assigning device variables.
- Always use a variable for the parameter to pass to *WriteDat*. A building error will occur if a constant is passed.
- You can execute only one instruction at a time for the IO-Link master unit regardless of its type (NX or GX).
- You cannot use this instruction in an event task. A compiling error will occur.
- This instruction is executed when *Execute* changes to TRUE. The instruction is not executed when *Execute* is always TRUE.
- You can use a maximum of 64 instances for the IOL_ReadObj and IOL_WriteObj instructions.
- An error will occur in the following cases.
 - A value that is out of range was set for *DevicePort.NxUnit* or *DevicePort.EcatSlave*.
 - The value of *TimeOut* is outside of the valid range.
 - The data type of *DevicePort* is invalid.
 - More than 232 bytes of data was specified for *WriteDat*.
 - An error response was received from the IO-Link device.
The upper eight bits represent *ErrorCode*, and lower eight bits represent *AdditionalCode*.
For *ErrorCode* and *AdditionalCode*, refer to the Error type specifications of the *IO-Link Communication Specification*. You can obtain the Error type specifications from the IO-Link Consortium.
<http://www.io-link.com/>
 - The specified IO-Link master unit does not exist.
 - The maximum number of messages that the IO-Link master can process is exceeded. Instruction execution is not possible because the IO-Link master is processing the messages from other applications.
 - The specified IO-Link master unit is not in a condition to receive messages.
 - More than 32 of the following instructions were executed at the same time: EC_CoESDOWrite, EC_CoESDORead, EC_StartMon, EC_StopMon, EC_SaveMon, EC_CopyMon, EC_DisconnectSlave, EC_ConnectSlave, EC_ChangeEnableSetting, IOL_ReadObj, and IOL_WriteObj.
 - A timeout occurred during communications.
 - The specified port of the IO-Link master unit is not the IO-Link mode. The port is disabled or in the SIO mode.
 - The IO-Link device is not connected to the specified port on the IO-Link master unit.
 - The IO power is not supplied to the specified port of the IO-Link master unit.
 - The specified port of the IO-Link master unit had a verification error or communications error.

Sample Programming

In this sample, an IO-Link master unit (NX-ILM400) is connected to an EtherCAT Coupler Unit (NX-ECC203).

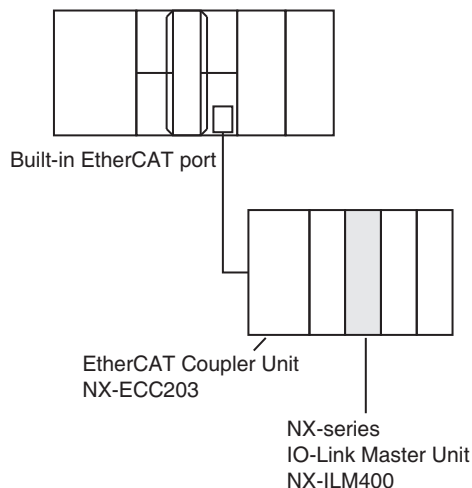

The value 01 is written to the one-byte SwitchPoint Logic Output 1 (Index: 61/Subindex: 1) of the photo-electric sensor (E3Z) connected to port 1 on the NX-ILM400. The written data is stored in *SwitchPoint*. The node address of the NX-ECC203 is 10.

LD

Internal Variables	Variable	Data type	Initial value	Comment
	Trigger	BOOL	FALSE	Execution condition
	WriteCondition	BOOL	FALSE	Data writing execution condition
	DevicePort	_sDEVICE_PORT		
	DeviceObject	_sIOLOBJ_ACCESS	(Index:=0, Sub-index:=0)	Specification for the IO-Link device object
	SwitchPoint	USINT	USINT#01	Write data
	IOL_WriteObj_instance	IOL_WriteObj		

External Variables	Variable	Constant	Initial value	Comment
	_EC_MBXSlavTbl	<input checked="" type="checkbox"/>	ARRAY[1..512] OF BOOL ^{*1}	Message Communications Enabled Slave Table
	IO_LINK_Unit	<input checked="" type="checkbox"/>	Set the device variable which specifies NX-ILM400 as the initial value of the structure member <i>NxUnit</i> .	

*1 For NJ-series CPU Units, the data type is ARRAY [1..192] OF BOOL.

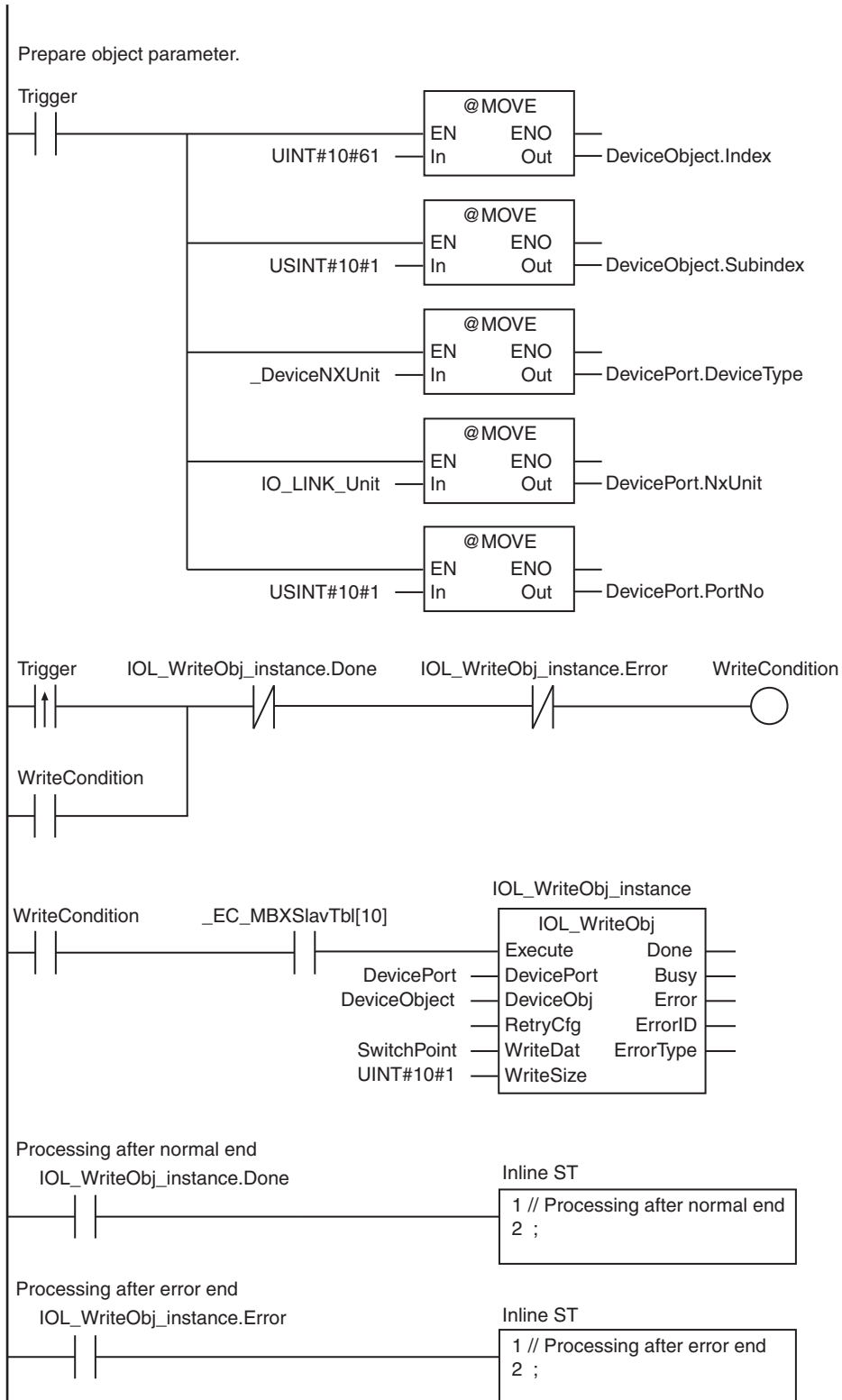

ST

Internal Variables	Variable	Data type	Initial value	Comment
	Trigger	BOOL	FALSE	Execution condition
	WriteGo	BOOL	FALSE	Data writing execution
	DevicePort	_sDEVICE_PORT		
	DeviceObject	_sIOLOBJ_ACCESS	(Index:=0, Sub-index:=0)	Specification for the IO-Link device object
	SwitchPoint	USINT	USINT#01	Write data
	NormalEnd	UINT	0	Normal end
	ErrorEnd	UINT	0	Error end
	R_Trig_instance	R_Trig		
	IOL_WriteObj_instance	IOL_WriteObj		

External Variables	Variable	Constant	Initial value	Comment
	_EC_MBXSlavTbl	☑	ARRAY[1..512] OF BOOL*1	Message Communications Enabled Slave Table
	IO_LINK_Unit	☑	Set the device variable which specifies NX-ILM400 as the initial value of the structure member <i>NxUnit</i> .	

*1 For NJ-series CPU Units, the data type is ARRAY [1..192] OF BOOL.

```
// Prepare object parameter.
R_Trig_instance(Clk := Trigger);
IF (R_Trig_instance.Q=TRUE) THEN
    DeviceObject.Index := USINT#10#61;
    DeviceObject.Subindex := USINT#1;
    DevicePort.DeviceType:= _eDEVICE_TYPE#_DeviceNXUnit;
    DevicePort.NxUnit:= IO_LINK_Unit;
    DevicePort.PortNo:= USINT#10#1;
    IF ( _EC_MBXSlavTbl [10] =TRUE) THEN
        WriteGo := TRUE;
    END_IF;
END_IF;

IF ( (IOL_WriteObj_instance.Done=TRUE) OR (IOL_WriteObj_instance.Error=TRUE) ) THEN
    WriteGo := FALSE;
END_IF;

// Execute IOL_WriteObj instruction.
IOL_WriteObj_instance(
    Execute := WriteGo,
    DevicePort:= DevicePort,
    DeviceObj := DeviceObject,
    WriteDat := SwitchPoint,
    WriteSize := USINT#10#1);

// Processing after instruction execution
IF (IOL_WriteObj_instance.Done=TRUE) THEN
    // Processing after normal end
    NormalEnd := NormalEnd + USINT#1;
END_IF;
```

```
ELSIF (IOL_WriteObj_instance.Error=TRUE) THEN
    // Processing after error end
    ErrorEnd := ErrorEnd + UINT#1;
END_IF;
```

EtherNet/IP Communications Instructions

Instruction	Name	Page	Instruction	Name	Page
CIPOpen	Open CIP Class 3 Connection (Large_Forward_Open)	2-1018	SkdTCPRcv	TCP Socket Receive	2-1099
CIPOpenWithDataSize	Open CIP Class 3 Connection with Specified Data Size	2-1027	SkdTCPSend	TCP Socket Send	2-1102
CIPRead	Read Variable Class 3 Explicit	2-1031	SkdGetTCPStatus	Read TCP Socket Status	2-1105
CIPWrite	Write Variable Class 3 Explicit	2-1037	SkdClose	Close TCP/UDP Socket	2-1108
CIPSend	Send Explicit Message Class 3	2-1043	SkdClearBuf	Clear TCP/UDP Socket Receive Buffer	2-1111
CIPClose	Close CIP Class 3 Connection	2-1048	SkdSetOption	Set TCP Socket Option	2-1114
CIPUCMMRead	Read Variable UCMM Explicit	2-1051	ChangeIPAdr	Change IP Address	2-1119
CIPUCMMWrite	Write Variable UCMM Explicit	2-1056	ChangeFTPAccount	Change FTP Account	2-1127
CIPUCMMSend	Send Explicit Message UCMM	2-1063	ChangeNTPServerAdr	Change NTP Server Address	2-1131
SkdUDPCreate	Create UDP Socket	2-1073	FTPGetFileList	Get FTP Server File List	2-1135
SkdUDPRcv	UDP Socket Receive	2-1081	FTPGetFile	Get File from FTP Server	2-1152
SkdUDPSend	UDP Socket Send	2-1084	FTPPutFile	Put File onto FTP Server	2-1161
SkdTCPAccept	Accept TCP Socket	2-1087	FTPRemoveFile	Delete FTP Server File	2-1172
SkdTCPConnect	Connect TCP Socket	2-1090	FTPRemoveDir	Delete FTP Server Directory	2-1182

CIPOpen

Opens a CIP class 3 connection (Large_Forward_Open) with the specified remote node. The data length is set to 1,994 bytes.

Instruction	Name	FB/ FUN	Graphic expression	ST expression
CIPOpen	Open CIP Class 3 Connection (Large_Forward_Open)	FB	<pre> graph LR subgraph CIPOpen_instance subgraph CIPOpen Execute --- Done RoutePath --- Busy TimeOut --- Error Error --- ErrorID ErrorID --- ErrorIDEx ErrorIDEx --- Handle end end </pre>	CIPOpen_instance(Execute, RoutePath, TimeOut, Done, Busy, Error, ErrorID, ErrorIDEx, Handle);

Variables

Name	Meaning	I/O	Description	Valid range	Unit	Default
RoutePath	Route path	Input	Route path	Depends on data type.	---	---
TimeOut	Timeout time		Timeout time	1 to 65535	0.1 s	20 (2 s)
Handle	Handle	Output	Handle	---	---	---

	Boolean	Bit strings					Integers							Real numbers	Times, durations, dates, and text strings					
	BOOL	BYTE	WORD	DWORD	LWORD	USINT	UINT	UDINT	ULINT	SINT	INT	DINT	LINT	REAL	LREAL	TIME	DATE	TOD	DT	STRING
RoutePath																				OK
TimeOut							OK													
Handle	Refer to <i>Function</i> for details on the structure <code>_sCIP_HANDLE</code> .																			

Function

The CIPOpen instruction opens a CIP class 3 connection (Large_Forward_Open) with a remote node on a CIP network. The remote node is specified with route path *RoutePath*. The data length is set to 1,994 bytes. *Handle* is output when the connection is open.

TimeOut specifies the connection timeout time. If a response does not return from the remote node within the connection timeout time after the CIPSend, CIPWrite, or CIPRead instruction is executed, it is assumed that communications failed. The connection timeout time is reset when the CIPRead, CIPWrite, or CIPSend instruction is executed and the remote node returns a response.

The data type of *Handle* is structure `_sCIP_HANDLE`. The specifications are as follows:

Name	Meaning	Description	Data type	Valid range	Unit	Default
Handle	Handle	Handle	<code>_sCIP_HANDLE</code>	---	---	---
Handle	Handle	Handle	UDINT	Depends on data type.	---	---

The following example is for when *RoutePath* is '02\192.168.250.2' and *TimeOut* is UINT#20. The Open CIP Class 3 Connection (*Large_Forward_Open*) instruction opens a CIP class 3 connection with the remote node with an IP address of 192.168.250.2. The timeout time is 2 s. The handle is assigned to variable *pqr*.

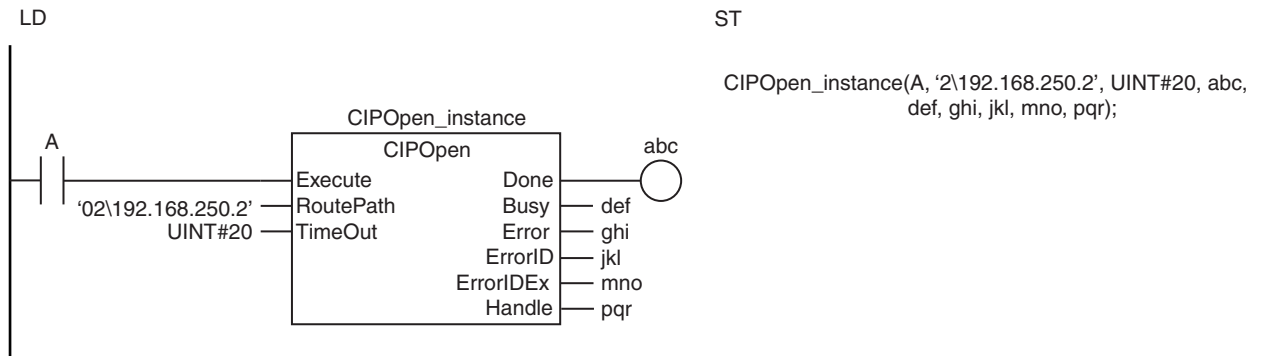

The Open CIP Class 3 Connection (*Large_Forward_Open*) instruction opens a CIP class 3 connection with a remote node on a CIP network. The remote node is specified with *RoutePath*.

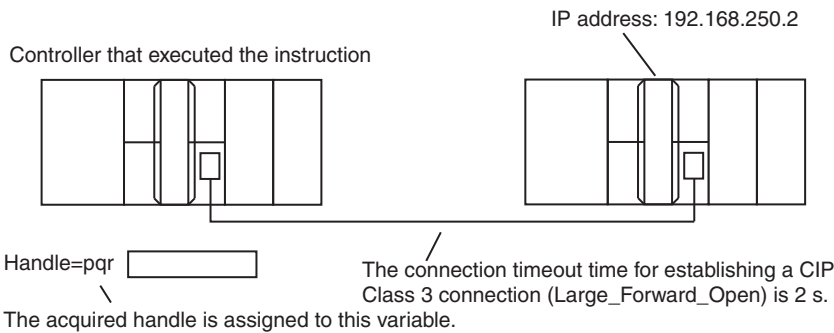

If the value of *ErrorID* is WORD#16#1C00, the CIP message error code is stored in *ErrorIDEx*. The meaning and values of *ErrorIDEx* depend on the remote node. Refer to the manual for the remote node.

Related System-defined Variables

Name	Meaning	Data type	Description
<u>_EIP_EtnOnlineSta</u> ^{*1}	Online	BOOL	This variable indicates when built-in EtherNet/IP port communications can be used. TRUE: Communications are possible. FALSE: Communications are not possible.
<u>_EIP1_EtnOnlineSta</u> ^{*2}			
<u>_EIP2_EtnOnlineSta</u> ^{*3}			
<u>_EIPIn1_EtnOnlineSta</u> ^{*4}			

*1 Use this variable name for an NJ-series CPU Unit.

*2 Use this variable name for port 1 on an NX-series CPU Unit, or for an NY-series Controller.

*3 Use this variable name for port 2 on an NX-series CPU Unit.

*4 Use this variable name for the internal port on an NY-series Controller.

Additional Information

- Refer to the following manuals for details on CIP communications.
 - NJ/NX-series CPU Unit Built-in EtherNet/IP Port User's Manual* (Cat. No. W506)
 - NY-series Industrial Panel PC / Industrial Box PC Built-in EtherNet/IP Port User's Manual* (Cat. No. W563)

- *CJ-series EtherNet/IP Units Operation Manual for NJ-series CPU Unit (Cat. No. W495)*
- To establish a Forward Open connection or a connection with any given data length, use *CIPOpenWithDataSize* on page 2-1027.



Version Information

A CPU Unit with unit version 1.06 or later and Sysmac Studio version 1.07 or higher are required to use the *CIPOpenWithDataSize* instruction.

Precautions for Correct Use

- Execution of this instruction is continued until processing is completed even if the value of *Execute* changes to FALSE or the execution time exceeds the task period. The value of *Done* changes to TRUE when processing is completed. Use this to confirm normal completion of processing.
- Refer to *Using this Section* on page 2-3 for a timing chart for *Execute*, *Done*, *Busy*, and *Error*.
- You must execute this instruction or the *CIPOpenWithDataSize* instruction before you execute the *CIPRead*, *CIPWrite*, or *CIPSend* instruction.
- For this instruction, the first timeout time after a connection is established is 10 s even if the value of *TimeOut* is set to less than 100 (10 s).
- Use the *CIPClose* instruction to close connections that were opened with the *CIPOpen* instruction.
- Even if the connection times out, the handle created by this instruction will remain. Always use the *CIPClose* instruction to close the connection.
- Handles that are created with this instruction are disabled when you change to PROGRAM mode.
- You can create a maximum of 32 handles at the same time.
- You can use this instruction only through a built-in EtherNet/IP port on an NY-series Controller or an NJ/NX-series CPU Unit, or through a port on an EtherNet/IP Unit connected to an NJ-series CPU Unit.
- An error occurs in the following cases. *Error* will change to TRUE.
 - The value of *TimeOut* is outside of the valid range.
 - The text string in *RoutePath* is not valid.
 - More than 32 CIP-related instructions were executed simultaneously.
 - An attempt was made to open a connection beyond the CIPClass connection resources (32 connections).
 - A connection opened response was not received.
 - The remote node to which to open a connection does not support *Large_Forward_Open*.
 - There is a setting error for the local IP address.
 - A duplicated IP error occurred.
 - All TCP connections are already in use.
 - The instruction was executed when there was a BOOTP server error.



Version Information

For CPU Unit version 1.10 or later, the value of *Handle* does not change even if *Error* changes to TRUE. For version 1.09 or earlier, the value of *Handle* changes to 0.

Sample Programming

This sample uses CIP class 3 messages to write a variable, read a variable, and send a message. The Controllers are connected to an EtherNet/IP network. The IP address of the remote node is 192.168.250.2.

The following procedure is used.

- 1** The CIPOpen is used to open a class 3 connection (Large_Forward_Open). The timeout time is 2 s.
- 2** The CIPWrite instruction is used to write the value of a variable at a remote node. The variable name at the remote node is *WritingDat* and the contents of the *WriteDat* is written to it. *WritingDat* must be defined as a global variable at the remote node and the Network Publish attribute must be set.
- 3** The CIPRead instruction is used to read the value of a variable at a remote node. The value of the variable *OriginalDat* at the other node is read and the read value is stored in the *ReadDat* variable. *OriginalDat* must be defined as a global variable at the remote node and the Network Publish attribute must be set.
- 4** The CIPSend instruction is used to send an explicit message to a remote node. The contents of the message is to read identity information (product name). The class ID, instance ID, attribute ID, and service code are as follows: The response data is stored in the *ResDat* variable.

Item	Value
Class ID	1
Instance ID	1
Attribute ID	7
Service code	16#0E

- 5** The CIPClose instruction is used to close the class 3 connection.

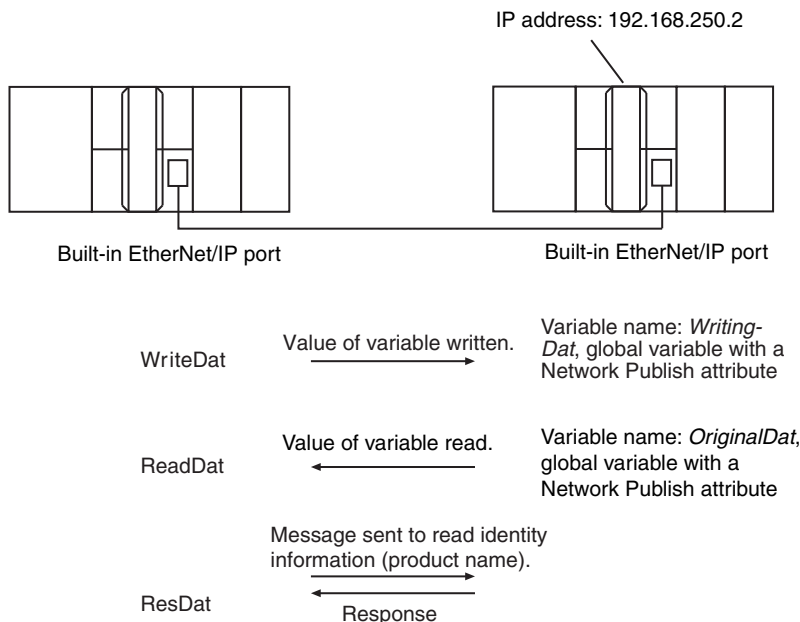

LD

Variable	Data type	Initial value	Comment
OperatingEnd	BOOL	FALSE	Processing completed
Trigger	BOOL	FALSE	Execution condition
Operating	BOOL	FALSE	Processing
WriteDat	INT	1234	Write data
ReadDat	INT	0	Read data
ReqPath	_sREQUEST_PATH	(ClassID:=0, InstanceID:=0, isAttributeID:=FALSE, AttributeID:=0)	Request path
ResDat	ARRAY[0..10] OF BYTE	[11(16#0)]	Response data
Dummy	BYTE	16#0	Dummy
RS_instance	RS		
CIPOpen_instance	CIPOpen		
CIPWrite_instance	CIPWrite		
CIPRead_instance	CIPRead		
CIPSend_instance	CIPSend		
CIPClose_instance	CIPClose		

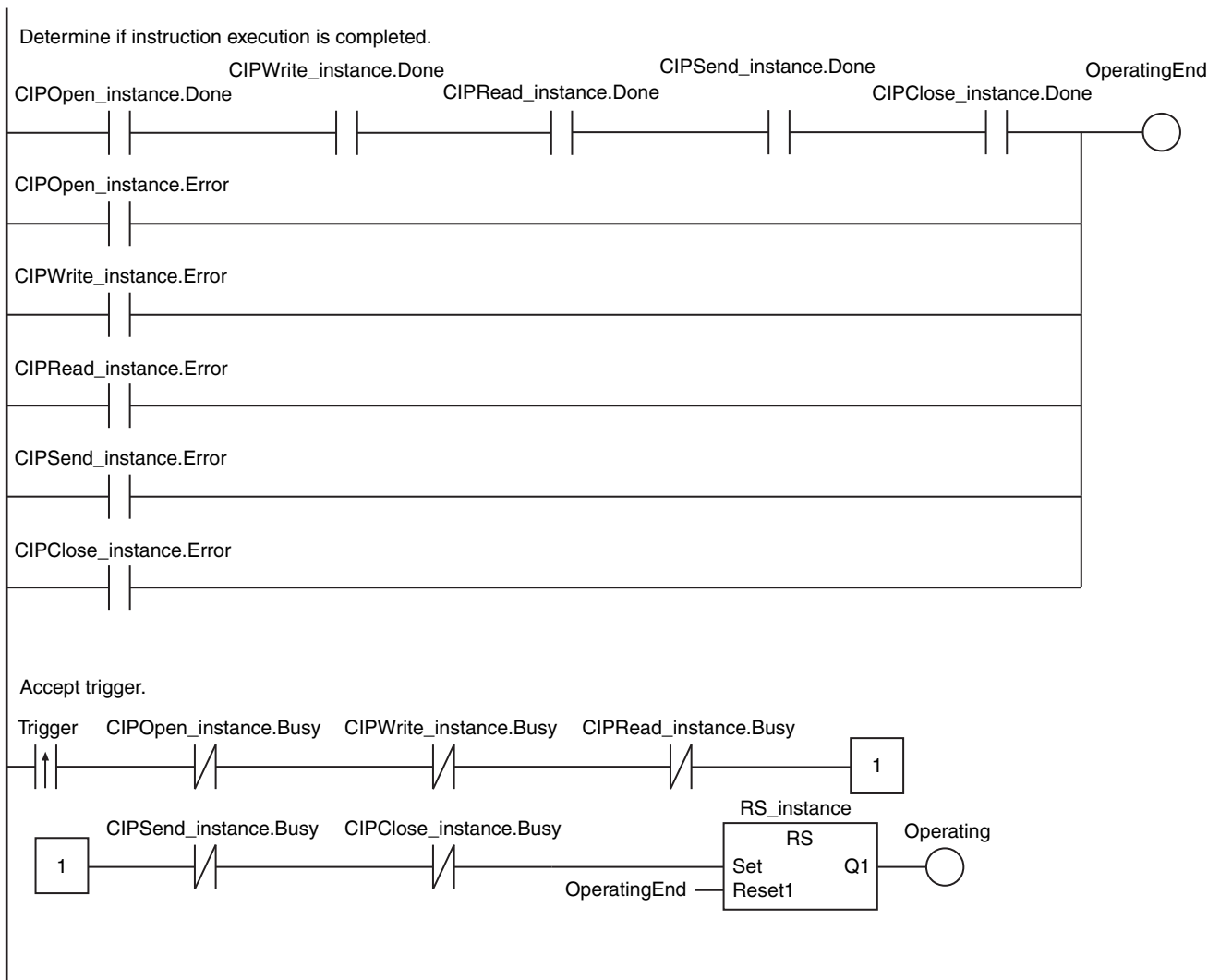

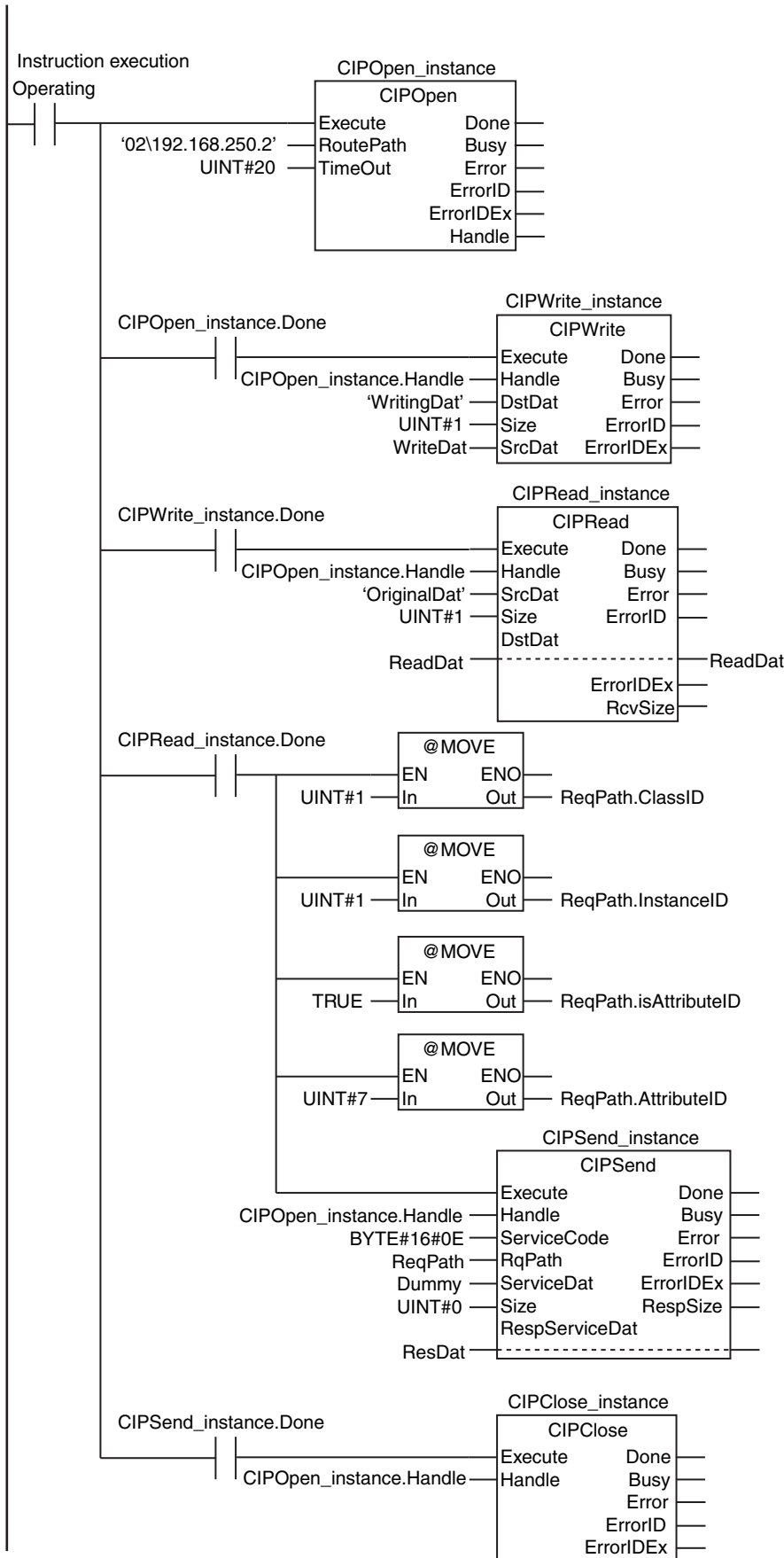

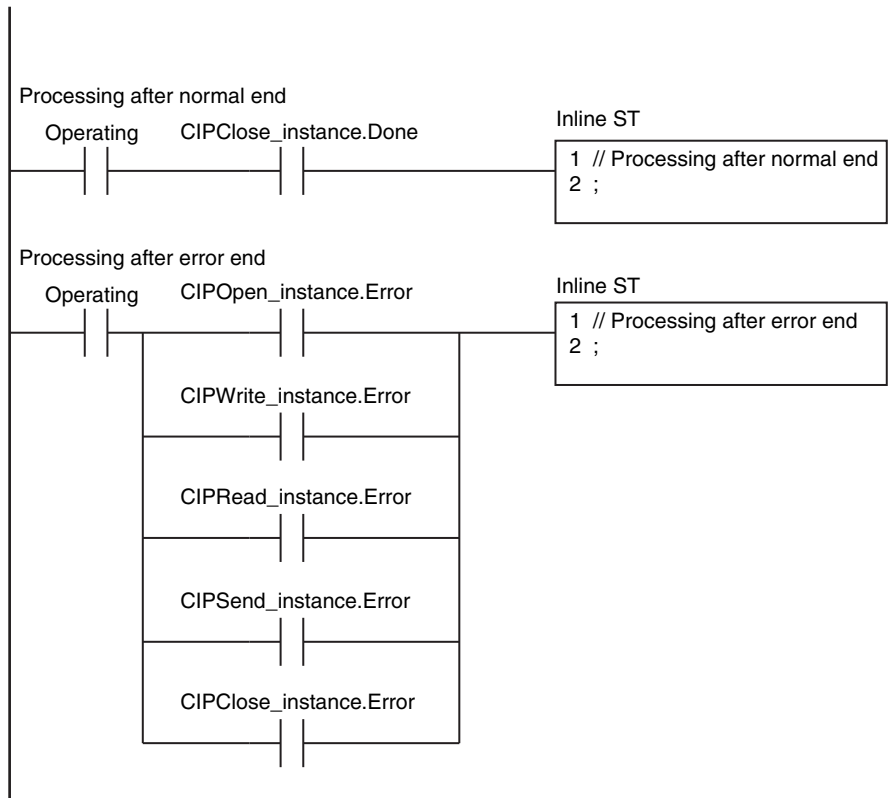

ST

Internal Variables	Variable	Data type	Initial value	Comment
	Trigger	BOOL	FALSE	Execution condition
	DoCIPTrigger	BOOL	FALSE	Processing
	Stage	INT	0	Stage change
	WriteDat	INT	0	Write data
	ReadDat	INT	0	Read data
	ReqPath	_sREQUEST_PATH	(ClassID:=0, InstanceID:=0, isAttributeID:=FALSE, AttributeID:=0)	Request path
	ResDat	ARRAY[0..10] OF BYTE	[11(16#0)]	Response data
	Dummy	BYTE	16#0	Dummy
	CIPOpen_instance	CIPOpen		
	CIPWrite_instance	CIPWrite		
	CIPRead_instance	CIPRead		
	CIPSend_instance	CIPSend		
	CIPClose_instance	CIPClose		

External Variables	Variable	Constant	Data type	Comment
	_EIP_EtnOnlineSta	✓	BOOL	Online

```
// Start sequence when Trigger changes to TRUE.
IF ( (Trigger=TRUE) AND (DoCIPTrigger=FALSE) AND (_Eip_EtnOnlineSta=TRUE) ) THEN
  DoCIPTrigger:=TRUE;
  Stage :=INT#1;
  CIPOpen_instance(Execute :=FALSE); // Initialize instance.
  CIPWrite_instance(
    Execute :=FALSE, // Initialize instance.
    SrcDat :=WriteDat); // Dummy
  CIPRead_instance( // Initialize instance.
    Execute :=FALSE, // Dummy
    DstDat :=ReadDat); // Dummy
  CIPSend_instance(
    Execute :=FALSE, // Initialize instance.
    ServiceDat := Dummy, // Dummy
    RespServiceDat :=ResDat); // Dummy
  CIPClose_instance(Execute:=FALSE); // Initialize instance.
END_IF;
```

```
IF (DoCIPTrigger=TRUE) THEN
  CASE Stage OF
  1 : // Open CIP Class 3 Connection (Large_Forward_Open)
    CIPOpen_instance(
      Execute :=TRUE,
      Timeout :=UINT#20, // Timeout time: 2.0 s
      RoutePath :='02\192.168.250.2'); // Route path

    IF (CIPOpen_instance.Done=TRUE) THEN
      Stage:=INT#2; // Normal end
    ELSIF (CIPOpen_instance.Error=TRUE) THEN
      Stage:=INT#10; // Error end
    END_IF;

  2 : // Request writing value of variable.
    CIPWrite_instance(
      Execute :=TRUE,
```

```

        Handle :=CIPOpen_instance.Handle, // Handle
        DstDat :='WritingDat',           // Destination variable name
        Size   :=UINT#1,                 // Number of elements to write
        SrcDat :=WriteDat);             // Write data

    IF (CIPWrite_instance.Done=TRUE) THEN
        Stage:=INT#3;                    // Normal end
    ELSIF (CIPWrite_instance.Error=TRUE) THEN
        Stage:=INT#20;                   // Error end
    END_IF;

3 :      // Request reading value of variable.
    CIPRead_instance(
        Execute :=TRUE,
        Handle   :=CIPOpen_instance.Handle, // Handle
        SrcDat   :='OriginalDat',           // Destination variable name
        Size     :=UINT#1,                 // Number of elements to read
        DstDat   :=ReadDat);             // Read data

    IF (CIPRead_instance.Done=TRUE) THEN
        Stage:=INT#4;                    // Normal end
    ELSIF (CIPRead_instance.Error=TRUE) THEN
        Stage:=INT#30;                   // Error end
    END_IF;

4 :      // Send message
    ReqPath.ClassID      :=UINT#01;
    ReqPath.InstanceID   :=UINT#01;
    ReqPath.isAttributeID :=TRUE;
    ReqPath.AttributeID  :=UINT#07;
    CIPSend_instance(
        Execute      :=TRUE,
        Handle       :=CIPOpen_instance.Handle, // Handle
        ServiceCode  :=BYTE#16#0E,           // Service code
        RqPath       :=ReqPath,              // Request path
        ServiceDat   :=Dummy,                // Service data
        Size         :=UINT#0,               // Number of elements
        RespServiceDat:=ResDat);            // Response data

    IF (CIPSend_instance.Done=TRUE) THEN
        Stage:=INT#5; // Normal end
    ELSIF (CIPSend_instance.Error=TRUE) THEN
        Stage:=INT#40; // Error end
    END_IF;

5 :      // Request closing CIP class 3 connection.
    CIPClose_instance(
        Execute :=TRUE,
        Handle  :=CIPOpen_instance.Handle); // Handle

    IF (CIPClose_instance.Done=TRUE) THEN
        Stage:=INT#0;
    ELSIF (CIPClose_instance.Error=TRUE) THEN
        Stage:=INT#50;
    END_IF;

0:      // Processing after normal end
    DoCIPTrigger:=FALSE;
    Trigger      :=FALSE;

    ELSE // Processing after error end
        DoCIPTrigger:=FALSE;
        Trigger      :=FALSE;
    END_CASE;
END_IF;

```

CIPOpenWithDataSize

The CIPOpenWithDataSize instruction opens a CIP class 3 connection with the specified remote node that allows class 3 explicit messages of the specified data length or shorter to be sent and received.

Instruction	Name	FB/ FUN	Graphic expression	ST expression
CIPOpenWith-DataSize	Open CIP Class 3 Connection with Specified Data Size	FB		CIPOpen_instance(Execute, RoutePath, TimeOut, DataSize, Done, Busy, Error, ErrorID, ErrorIDEx, Handle);

Variables

Name	Meaning	I/O	Description	Valid range	Unit	Default
RoutePath	Route path	Input	Route path	Depends on data type.	---	---
TimeOut	Timeout time		Timeout time	1 to 65,535	0.1 s	20 (2s)
DataSize	Data length		Data length	6 to 8,192*1*2	Bytes	1994
Handle	Handle	Output	Handle	---	---	---

*1 The range is 6 to 1,994 for NX1P2 and NJ-series CPU Units.

*2 With a CPU Unit with unit version 1.10 or earlier or Sysmac Studio version 1.14 or lower, the minimum value is 10.

	Boolean	Bit strings				Integers								Real numbers		Times, durations, dates, and text strings				
	BOOL	BYTE	WORD	DWORD	LWORD	USINT	UINT	UDINT	ULINT	SINT	INT	DINT	LINT	REAL	LREAL	TIME	DATE	TOD	DT	STRING
RoutePath																				OK
TimeOut							OK													
DataSize							OK													
Handle	Refer to <i>Function</i> for details on the structure <code>_sCIP_HANDLE</code> .																			

Function

The CIPOpenWithDataSize instruction opens a CIP class 3 connection with a remote node on a CIP network. The remote node is specified with route path *RoutePath*. Data length *DataSize* specifies the data length of class 3 explicit messages that can be sent and received.

The class 3 connection service is determined by the value of *DataSize* as given in the following table.

Value of <i>DataSize</i> [bytes]	Service
509 or less	Forward_Open
510 to 8,192*1	Large_Forward_Open

*1 The range is 510 to 1,994 for NX1P2 and NJ-series CPU Units.

Handle is output when the connection is open.

TimeOut specifies the connection timeout time. If a response does not return from the remote node within the connection timeout time after the CIPSend, CIPWrite, or CIPRead instruction is executed, it is assumed that communications failed. The connection timeout time is reset when the CIPRead, CIPWrite, or CIPSend instruction is executed and the remote node returns a response.

The data type of *Handle* is structure *_sCIP_HANDLE*. The specifications are as follows:

Name	Meaning	Description	Data type	Valid range	Unit	Default
Handle	Handle	Handle	_sCIP_HANDLE	---	---	---
Handle	Handle	Handle	UDINT	Depends on data type.	---	---

The following example is for when *RoutePath* is '02\192.168.250.2' and *TimeOut* is UINT#20. The CIPOpenWithDataSize instruction opens a CIP class 3 connection with the remote node with an IP address of 192.168.250.2. The data length is 1,994 bytes and the timeout time is 2 s. The handle is assigned to variable *pqr*.

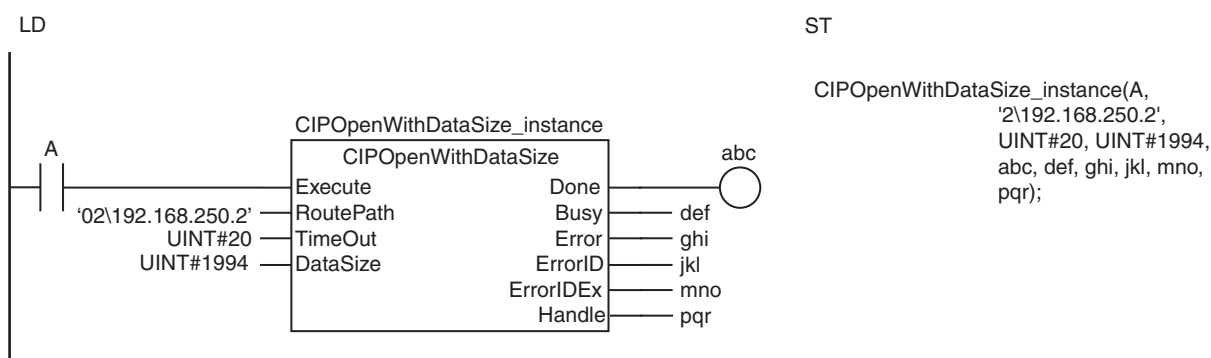

The CIPOpenWithDataSize instruction opens a CIP class 3 connection with a remote node on a CIP network. The remote node is specified with *RoutePath*.

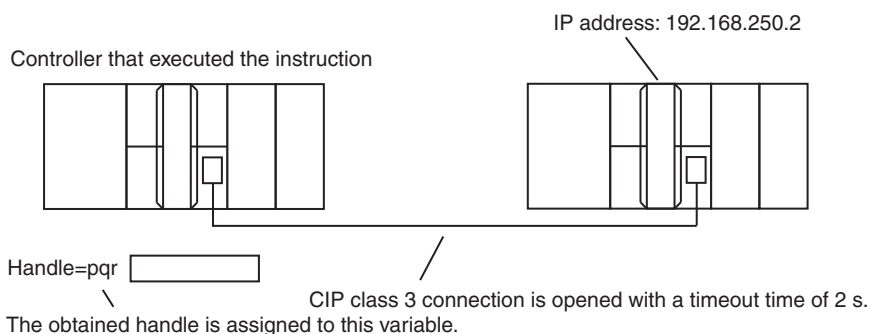

If the value of *ErrorID* is WORD#16#1C00, the CIP message error code is stored in *ErrorIDEx*. The meaning and values of *ErrorIDEx* depend on the remote node. Refer to the manual for the remote node.

Related System-defined Variables

Name	Meaning	Data type	Description
<i>_EIP_EtnOnlineSta</i> *1	Online	BOOL	This variable indicates when built-in EtherNet/IP port communications can be used. TRUE: Communications are possible. FALSE: Communications are not possible.
<i>_EIP1_EtnOnlineSta</i> *2			
<i>_EIP2_EtnOnlineSta</i> *3			
<i>_EIPIn1_EtnOnlineSta</i> *4			

*1 Use this variable name for an NJ-series CPU Unit.

- *2 Use this variable name for port 1 on an NX-series CPU Unit, or for an NY-series Controller.
- *3 Use this variable name for port 2 on an NX-series CPU Unit.
- *4 Use this variable name for the internal port on an NY-series Controller.

Additional Information

- Refer to the following manuals for details on CIP communications.
 - *NJ/NX-series CPU Unit Built-in EtherNet/IP Port User's Manual* (Cat. No. W506)
 - *NY-series Industrial Panel PC / Industrial Box PC Built-in EtherNet/IP Port User's Manual* (Cat. No. W563)
 - *CJ-series EtherNet/IP Units Operation Manual for NJ-series CPU Unit* (Cat. No. W495)
- To use `Large_Forward_Open` as the class 3 connection service, you can also use the `CIPOpen` instruction (page 2-1018).

Precautions for Correct Use

- Execution of this instruction is continued until processing is completed even if the value of *Execute* changes to FALSE or the execution time exceeds the task period. The value of *Done* changes to TRUE when processing is completed. Use this to confirm normal completion of processing.
- Refer to *Using this Section* (page 2-3) for a timing chart for *Execute*, *Done*, *Busy*, and *Error*.
- You must execute this instruction or the `CIPOpen` instruction before you execute the `CIPRead`, `CIPWrite`, or `CIPSend` instruction.
- For this instruction, the first timeout time after a connection is established is 10 s even if the value of *Timeout* is set to less than 100 (10 s).
- Use the `CIPClose` instruction to close connections that were opened with the `CIPOpenWithDataSize` instruction.
- Even if the connection times out, the handle created by this instruction will remain. Always use the `CIPClose` instruction to close the connection.
- Handles that are created with this instruction are disabled when you change to PROGRAM mode.
- You can create a maximum of 32 handles at the same time.
- You can use this instruction only through a built-in EtherNet/IP port on an NY-series Controller or an NJ/NX-series CPU Unit, or through a port on an EtherNet/IP Unit connected to an NJ-series CPU Unit.
- An error occurs in the following cases. *Error* will change to TRUE.
 - The value of *Timeout* is outside of the valid range.
 - The text string in *RoutePath* is not valid.
 - More than 32 CIP-related instructions were executed simultaneously.
 - An attempt was made to open a connection beyond the `CIPClass` connection resources (32 connections).
 - A connection opened response was not received.
 - The value of *DataSize* is 510 to 1,994 and the remote node to which to open a connection does not support `Large_Forward_Open`.
 - There is a setting error for the local IP address.
 - A duplicated IP error occurred.
 - All TCP connections are already in use.
 - The instruction was executed when there was a BOOTP server error.



Version Information

- A CPU Unit with unit version 1.06 or later and Sysmac Studio version 1.07 or higher are required to use this instruction.
 - For CPU Unit version 1.10 or later, the value of *Handle* does not change even if *Error* changes to TRUE. For version 1.09 or earlier, the value of *Handle* changes to 0.
-

CIPRead

The CIPRead instruction uses a class 3 explicit message to read the value of a variable in another Controller on a CIP network.

Instruction	Name	FB/ FUN	Graphic expression	ST expression
CIPRead	Read Variable Class 3 Explicit	FB	<pre> graph LR subgraph CIPRead_instance [CIPRead_instance] direction TB CIPRead[CIPRead] end Execute --- CIPRead Handle --- CIPRead SrcDat --- CIPRead Size --- CIPRead DstDat --- CIPRead CIPRead --- Done CIPRead --- Busy CIPRead --- Error CIPRead --- ErrorID CIPRead --- ErrorIDEx CIPRead --- RcvSize </pre>	CIPRead_instance(Execute, Handle, SrcDat, Size, DstDat, Done, Busy, Error, ErrorID, ErrorIDEx, RcvSize);

Variables

Name	Meaning	I/O	Description	Valid range	Unit	Default
Handle	Handle	Input	Handle obtained with CIPOpen or CIPOpenWithDataSize instruction	---	---	---
SrcDat	Source variable name		Name of variable to read in other Controller	Depends on data type.		"
Size	Number of elements to read		Number of elements to read	0 to 8,186*1		1
DstDat	Read data	In-out	Read data value	Depends on data type.	---	---
RcvSize	Read data size	Output	Read data size	0 to 8,186*1	Bytes	---

*1 The range is 0 to 1,988 for NX1P2 and NJ-series CPU Units.

	Boolean	Bit strings				Integers							Real numbers	Times, durations, dates, and text strings						
	BOOL	BYTE	WORD	DWORD	LWORD	USINT	UINT	UDINT	ULINT	SINT	INT	DINT	LINT	REAL	LREAL	TIME	DATE	TOD	DT	STRING
Handle		Refer to <i>Function</i> for details on the structure <code>_sCIP_HANDLE</code> .																		
SrcDat																				OK
Size							OK													
DstDat	OK	OK	OK	OK	OK	OK	OK	OK	OK	OK	OK	OK	OK	OK	OK	OK	OK	OK	OK	OK
	An enumeration, array, structure, structure member, or union member can also be specified.*																			
RcvSize							OK													

* You cannot specify a STRING array.

Function

The CIPRead instruction reads the value of the network variable specified with source variable name *SrcDat* from another Controller on a CIP network. The other Controller is specified with *Handle*.

The read data value is stored in *DstDat*.

Size specifies the number of elements to read. If *SrcDat* is an array, specify the number of elements to read with *Size*. If *SrcDat* is not an array, always specify 1 for *Size*. If the value of *Size* is 0, nothing is read regardless of whether *SrcDat* is an array or not.

When the read operation is completed, the number of bytes of the data that was read is assigned to read data size *RcvSize*.

The maximum size of the data that you can read depends on the instruction that established the connection and the data type of the data that is read as shown in the following table.

Instruction that established the connection	Data type of read data	Maximum size of data that you can read [bytes]
CIPOpen	Structure	1984
	STRING	1986
	Other data type	1988
CIPOpenWithDataSize	Structure	<i>DataSetSize</i> in CIPOpenWithDataSize instruction – 10
	STRING	<i>DataSetSize</i> in CIPOpenWithDataSize instruction – 8
	Other data type	<i>DataSetSize</i> in CIPOpenWithDataSize instruction – 6

The data type of *Handle* is structure `_sCIP_HANDLE`. The specifications are as follows:

Name	Meaning	Description	Data type	Valid range	Unit	Default
Handle	Handle	Handle	<code>_sCIP_HANDLE</code>	---	---	---
Handle	Handle	Handle	UDINT	Depends on data type.	---	---

If the value of *ErrorID* is `WORD#16#1C00`, the CIP message error code is stored in *ErrorIDEx*.

In the following example, the value of variable *abc* in the remote Controller is read and stored in the variable *def* in the local Controller. The number of elements to read *Size* is `UINT#1`. The data type of *abc* and *def* is `SINT`. The size of `SINT` data is one byte, so the value of the read data size *vwx* is `UINT#1`.

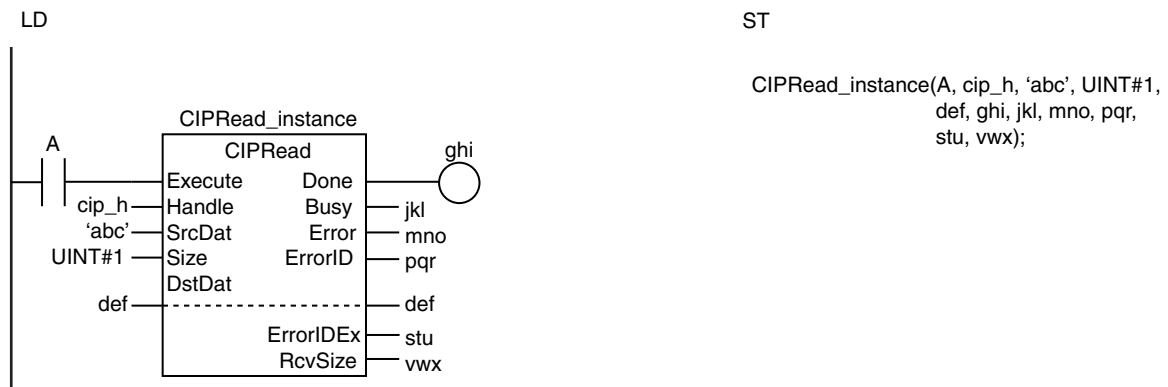

The value of variable *SrcDat* in remote Controller on the CIP network specified by the handle *Handle* is assigned to variable *DstDat* in the local Controller. *Size* specifies the number of elements to read. The size of data that was read is assigned to *RcvSize*.

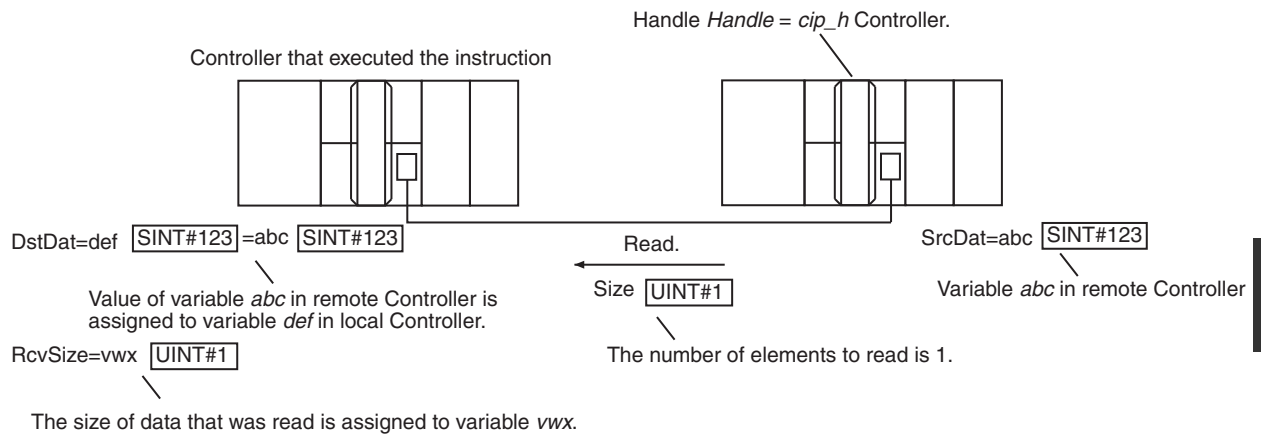

Reading Arrays

To read array data, pass a subscripted array element to *SrcDat* as the parameter. Also pass a subscripted array element to *DstDat* as the parameter.

The following example reads the four array variable elements *abc[3]* to *abc[6]* from the remote Controller and stores the results in array variable elements *def[10]* to *def[13]* in the local Controller. The data type of *abc* and *def* is INT. The size of INT data is two bytes, so the value of the read data size *vwx* is *UINT#8*.

LD

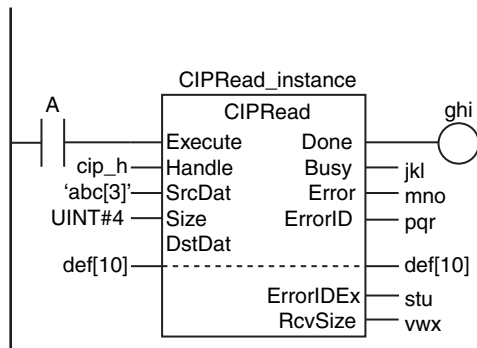

ST

```
CIPRead_instance(A, cip_h, 'abc[3]', UINT#4,
def[10], ghi, jkl, mno, pqr,
stu, vwx);
```

Values of array variable elements *abc[3]* to *abc[6]* in remote Controller are assigned to array variable elements *def[10]* to *def[13]* in local Controller.

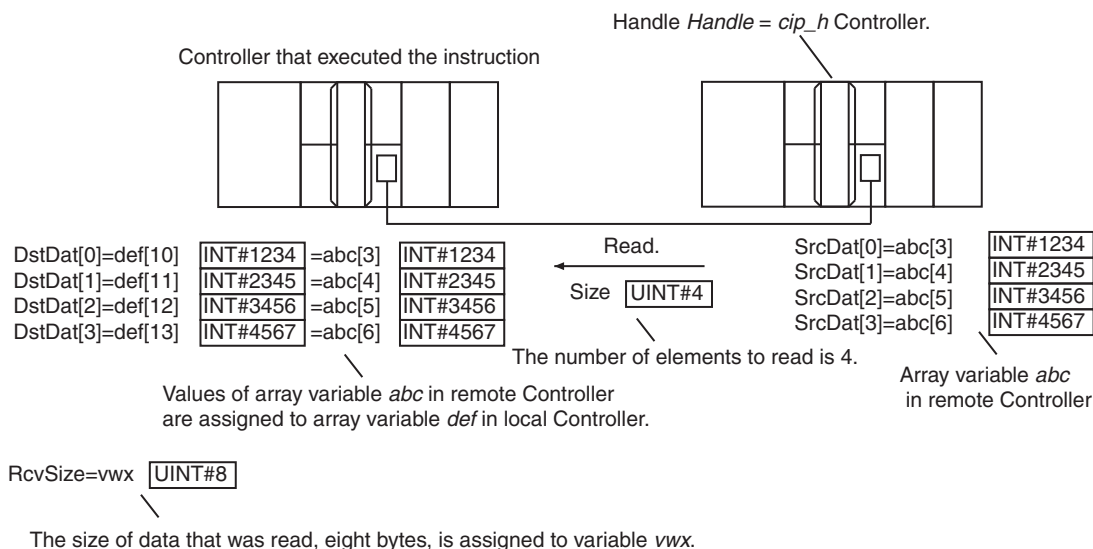

Related System-defined Variables

Name	Meaning	Data type	Description
<u>_EIP_EtnOnlineSta</u> ^{*1}	Online	BOOL	This variable indicates when built-in EtherNet/IP port communications can be used. TRUE: Communications are possible. FALSE: Communications are not possible.
<u>_EIP1_EtnOnlineSta</u> ^{*2}			
<u>_EIP2_EtnOnlineSta</u> ^{*3}			
<u>_EIPIn1_EtnOnlineSta</u> ^{*4}			

*1 Use this variable name for an NJ-series CPU Unit.

*2 Use this variable name for port 1 on an NX-series CPU Unit, or for an NY-series Controller.

*3 Use this variable name for port 2 on an NX-series CPU Unit.

*4 Use this variable name for the internal port on an NY-series Controller.

Additional Information

Refer to the following manuals for details on CIP communications.

- *NJ/NX-series CPU Unit Built-in EtherNet/IP Port User's Manual* (Cat. No. W506)
- *NY-series Industrial Panel PC / Industrial Box PC Built-in EtherNet/IP Port User's Manual* (Cat. No. W563)
- *CJ-series EtherNet/IP Units Operation Manual for NJ-series CPU Unit* (Cat. No. W495)

Precautions for Correct Use

- Execution of this instruction is continued until processing is completed even if the value of *Execute* changes to FALSE or the execution time exceeds the task period. The value of *Done* changes to TRUE when processing is completed. Use this to confirm normal completion of processing.
- Refer to *Using this Section* on page 2-3 for a timing chart for *Execute*, *Done*, *Busy*, and *Error*.
- Execute the *CIPOpen* or *CIPOpenWithDataSize* instruction to obtain the value for *Handle* before you execute this instruction.
- You can use this instruction only through a built-in EtherNet/IP port on an NY-series Controller or an NJ/NX-series CPU Unit, or through a port on an EtherNet/IP Unit connected to an NJ-series CPU Unit.

- If a variable is read from an OMRON Controller, the variable must be published to the network. Publish the variable to the network in advance.
- You cannot specify an address in memory for CJ-series Units directly to read data. To read specific addresses in memory for CJ-series Units, use an AT specification in advance to assign the memory addresses to a variable.
- You cannot specify an address in local memory for CJ-series Units directly to store data. To store data in specific addresses in memory for CJ-series Units, use an AT specification in advance to assign the memory addresses to *DstDat*.
- The characters that can be used in *SrcDat* are specified in the following table.

Item	Specification
Maximum number of bytes	127 bytes
Character code	UTF-8
Applicable characters	Alphanumeric characters (not case sensitive), single-byte Katakana, multibyte characters, and '_' (underbars)
Prohibited text strings	<ul style="list-style-type: none"> • Any text string that starts with ASCII characters 0 to 9 (character codes 16#30 to 16#39) • A text string that consists of only a single _ (underbar) ASCII character • Any text string that includes two or more consecutive _ (underbar) ASCII characters • Any text string that starts with an _ (underbar) ASCII character • Any text string that ends with an _ (underbar) ASCII character • Any text string that starts with "P_"

- An error occurs in the following cases. *Error* will change to TRUE.
 - The value of *Size* is outside of the valid range.
 - The text string in *SrcDat* is not valid.
 - The data type of the value that was read does not agree with the data type of *DstDat*.
 - The size of data that was read exceeds the range of *DstDat*.
 - A data type that is not supported was specified for *DstDat*.
 - An error response defined by CIP was returned.
 - The value of *Handle.Handle* is outside of the valid range.
 - More than 32 CIP-related instructions were executed simultaneously.
 - The connection that was established with the CIPOpen or CIPOpenWithDataSize instruction has timed out.
 - The size of *SrcDat* exceeded the data size determined by the instruction that established the connection and the data type of the read data.

- For this instruction, expansion error code *ErrorIDEx* gives the CIP message error code. The meanings are as follows:

Value	Error
16#02000000	Normal communications are not possible due to a high load at the remote node.
16#04000000	The specified source variable is one of the following data types and it does not exist on the other Controller. <ul style="list-style-type: none"> Basic data type Enumeration Structure Union Array
16#05000000	The specified source variable is one of the following and it does not exist on the other Controller. <ul style="list-style-type: none"> Enumeration enumerator Structure member Union member Array element
16#08000000	The requested service does not support.
16#0C008010	The specified source variable is being downloaded.
16#0C008011	
16#11000000	The value of Size exceeds the data size that can currently be read.
16#1F000102	The variable to read is a variable that is not possible to read.
16#1F008007	The inaccessible variable is specified.
16#20008017	The specified source variable is not an array and the number of elements to read is not 1.
16#20008018	The specified source variable is an array and the number of elements to read exceeds the number of elements in the array.
16#26000000	The specified destination variable contains only the NULL character.

Sample Programming

Refer to the sample programming that is provided for the CIPOpen instruction (page 2-1018).

CIPWrite

The CIPWrite instruction uses a class 3 explicit message to write the value of a variable in another Controller on a CIP network.

Instruction	Name	FB/ FUN	Graphic expression	ST expression
CIPWrite	Write Variable Class 3 Explicit	FB	<pre> graph LR subgraph CIPWrite_instance [CIPWrite_instance] CIPWrite end Execute --- CIPWrite Handle --- CIPWrite DstDat --- CIPWrite Size --- CIPWrite SrcDat --- CIPWrite CIPWrite --- Done CIPWrite --- Busy CIPWrite --- Error CIPWrite --- ErrorID CIPWrite --- ErrorIDEx </pre>	CIPWrite_instance(Execute, Handle, DstDat, Size, SrcDat, Done, Busy, Error, ErrorID, ErrorIDEx);

Variables

Name	Meaning	I/O	Description	Valid range	Unit	Default
Handle	Handle	Input	Handle obtained with CIPOpen or CIPOpenWithDataSize instruction	---	---	---
DstDat	Destination variable name		Name of variable to write in another Controller	Depends on data type.		"
Size	Number of elements to write		Number of elements to write	0 to 8,178*1	---	1
SrcDat	Source data		Data value to write	Depends on data type.		*2

*1 The range is 0 to 1,980 for NX1P2 and NJ-series CPU Units.

*2 If you omit an input parameter, the default value is not applied. A building error will occur.

	Boolean	Bit strings				Integers							Real numbers	Times, durations, dates, and text strings							
	BOOL	BYTE	WORD	DWORD	LWORD	USINT	UINT	UDINT	ULINT	SINT	INT	DINT	LINT	REAL	LREAL	TIME	DATE	TOD	DT	STRING	
Handle																					
	Refer to <i>Function</i> for details on the structure <code>_sCIP_HANDLE</code> .																				
DstDat																					OK
Size							OK														
SrcDat	OK	OK	OK	OK	OK	OK	OK	OK	OK	OK	OK	OK	OK	OK	OK	OK	OK	OK	OK	OK	OK
Handle	An enumeration, array*, structure, structure member, or union member can also be specified.																				

* You cannot specify a STRING array.

Function

The CIPWrite instruction writes the value of the network variable specified with destination variable name *DstDat* at another Controller on a CIP network. The other Controller is specified with *Handle*. The content of source data *SrcDat* is written.

Size specifies the number of elements to write. If *DstDat* is an array, specify the number of elements to write with *Size*. If *DstDat* is not an array, always specify 1 for *Size*. If the value of *Size* is 0, nothing is written regardless of whether *DstDat* is an array or not.

The data type of *Handle* is structure `_sCIP_HANDLE`. The specifications are as follows:

Name	Meaning	Description	Data type	Valid range	Unit	Default
Handle	Handle	Handle	<code>_sCIP_HANDLE</code>	---	---	---
Handle	Handle	Handle	UDINT	Depends on data type.	---	---

If the value of *ErrorID* is `WORD#16#1C00`, the CIP message error code is stored in *ErrorIDEx*.

The following example writes the value of variable *def* from the local Controller to the variable *abc* in the remote Controller. The number of elements to write *Size* is `UINT#1`.

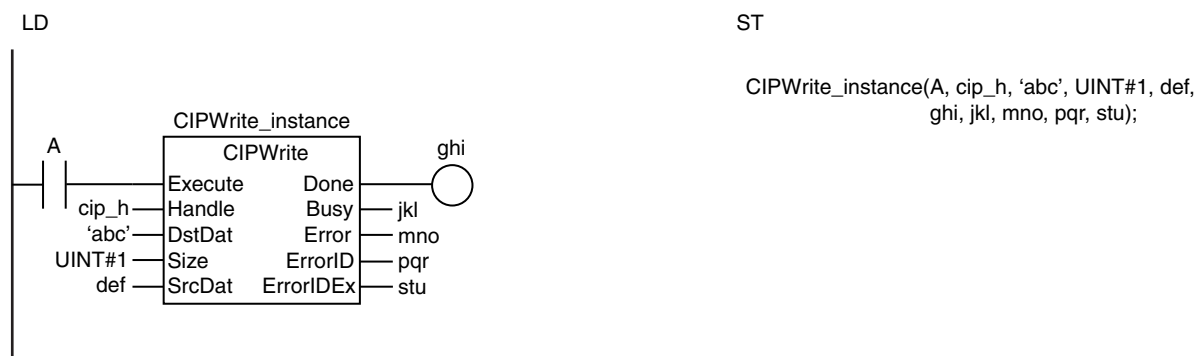

```
CIPWrite_instance(A, cip_h, 'abc', UINT#1, def,
ghi, jkl, mno, pqr, stu);
```

The value of variable *SrcDat* in the local Controller is assigned to variable *DstDat* in the remote Controller on the CIP network specified by the handle *Handle*. *Size* specifies the number of elements to write.

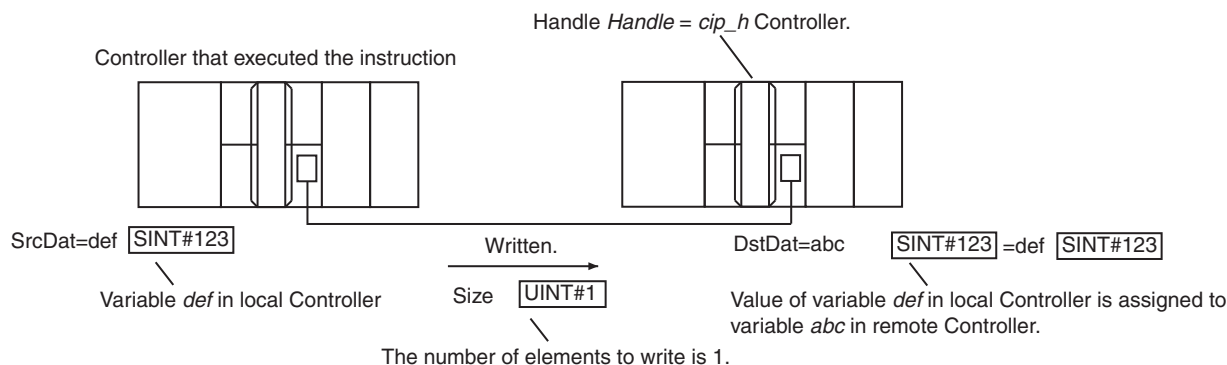

Writing Arrays

To write array data, pass a subscripted array element to *DstDat* as the parameter. Also pass a subscripted array element to *SrcDat* as the parameter.

The following example stores the contents of array variable elements *def[10]* to *def[13]* in the four array variable elements *abc[3]* to *abc[6]*.

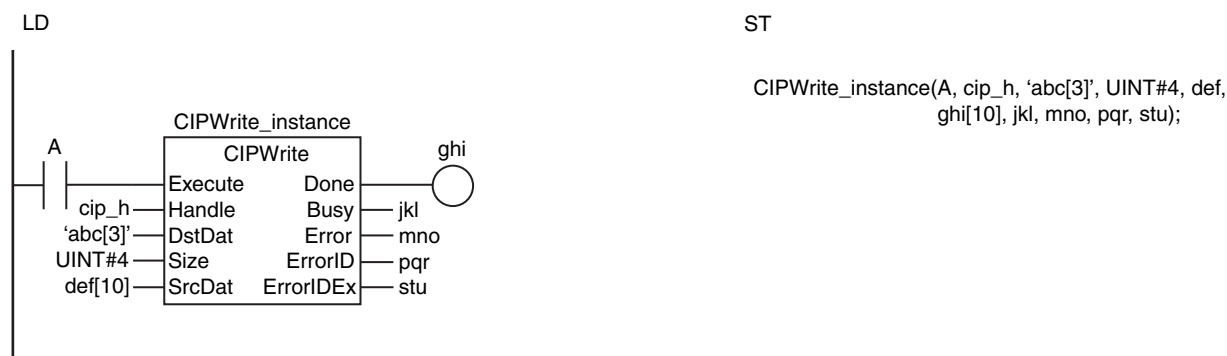

```
CIPWrite_instance(A, cip_h, 'abc[3]', UINT#4, def,
ghi[10], jkl, mno, pqr, stu);
```

Values of array variable elements *def*[10] to *def*[13] in local Controller are assigned to array variable elements *abc*[3] to *abc*[6] in remote Controller.

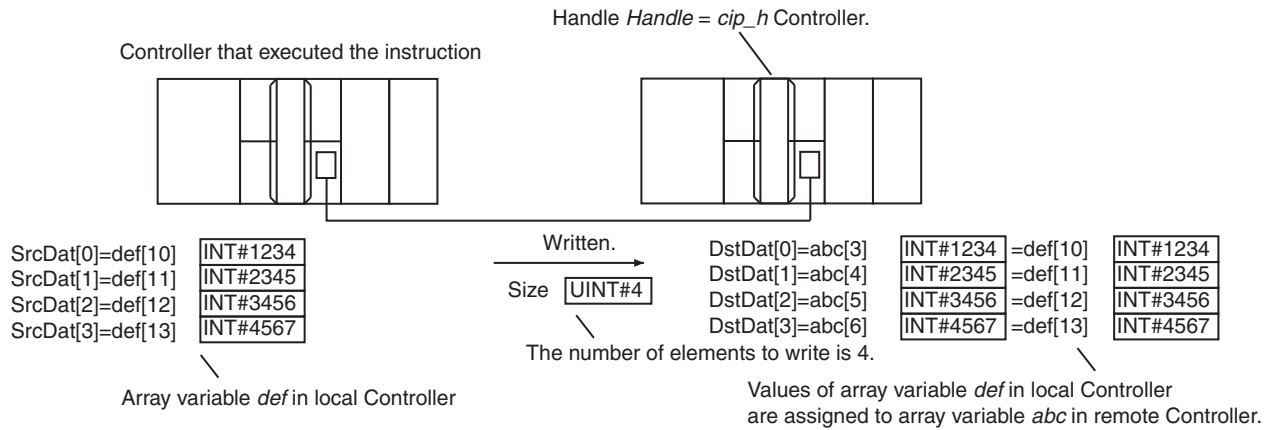

Maximum Write Data Size

The maximum size of the data that you can write depends on the data type and variable name that are specified for *DstDat*, as given in the following table.

Maximum write data size [bytes] = Base size – Size of variable name of *DstDat*

Item in above formula	Meaning
Base size	Connections established with the CIPOpen instruction <ul style="list-style-type: none"> Data type of variable specified for <i>DstDat</i> is a structure: 1,984 bytes Data type of variable specified for <i>DstDat</i> is a STRING: 1,986 bytes Other data types: 1,988 bytes
	Connections established with the CIPOpenWithDataSize instruction <ul style="list-style-type: none"> Use the following formula when the data type of variable specified for <i>DstDat</i> is a structure: Base size [bytes] = <i>DataSize</i> in CIPOpenWithDataSize instruction – 10 Use the following formula when the data type of variable specified for <i>DstDat</i> is a STRING: Base size [bytes] = <i>DataSize</i> in CIPOpenWithDataSize instruction – 8 Use the following formula for other data types. Base size [bytes] = <i>DataSize</i> in CIPOpenWithDataSize instruction – 6

Item in above formula	Meaning
Size of variable name of <i>DstDat</i>	<ul style="list-style-type: none"> The size of the variable name is calculated as the total bytes for the ASCII characters in all structure levels plus two times the number of levels. If the number of bytes of ASCII characters in a level is an odd number, add 1. If a level in the structure is an array, add four times the number of dimensions in the array. Periods and commas in the structure and arrays are not included in the variable name size. <p>Example 1: When the Variable Name of <i>DstDat</i> Is <i>aaa.bbbbb[1,2,3].cc</i></p> <ul style="list-style-type: none"> The text string “aaa” in the first level is 3 bytes. It is an odd number, so 1 is added to make 4 bytes. The text string “bbbb[1,2,3]” in the second level is 5 bytes. It is an odd number, so 1 is added to make 6 bytes. Also <i>bbbb[1,2,3]</i> is a three-dimensional array, so 3 times 4, or 12, is added to make 18 bytes. The text string “cc” in the third level is 2 bytes. It is an even number, so 2 bytes is used in the calculation. If we add the number of levels 3 times 2, or 6, to 4 bytes for the first level, 18 bytes for the second level, and 2 bytes for the third level, the size of the variable name come to 30 bytes. <p>Example 2: When the Variable Name of <i>DstDat</i> Is <i>val</i></p> <ul style="list-style-type: none"> The text string “val” in the first level is 3 bytes. It is an odd number, so 1 is added to make 4 bytes. If we then add the number of levels 1 times 2, or 2, the size of the variable name is 6 bytes. <p>Example 3: When the Variable Name of <i>DstDat</i> Is <i>array[8]</i>.</p> <ul style="list-style-type: none"> The text string “array” in the first level is 5 bytes. It is an odd number, so 1 is added to make 6 bytes. It is a one-dimensional array. Therefore, 1 times 4, or 4, is added. If we then add the number of levels 1 times 2, or 2, the size of the variable name is 12 bytes.

Related System-defined Variables

Name	Meaning	Data type	Description
<i>_EIP_EtnOnlineSta</i> *1	Online	BOOL	This variable indicates when built-in EtherNet/IP port communications can be used. TRUE: Communications are possible. FALSE: Communications are not possible.
<i>_EIP1_EtnOnlineSta</i> *2			
<i>_EIP2_EtnOnlineSta</i> *3			
<i>_EIPIn1_EtnOnlineSta</i> *4			

*1 Use this variable name for an NJ-series CPU Unit.

*2 Use this variable name for port 1 on an NX-series CPU Unit, or for an NY-series Controller.

*3 Use this variable name for port 2 on an NX-series CPU Unit.

*4 Use this variable name for the internal port on an NY-series Controller.

Additional Information

Refer to the following manuals for details on CIP communications.

- NJ/NX-series CPU Unit Built-in EtherNet/IP Port User's Manual* (Cat. No. W506)
- NY-series Industrial Panel PC / Industrial Box PC Built-in EtherNet/IP Port User's Manual* (Cat. No. W563)
- CJ-series EtherNet/IP Units Operation Manual for NJ-series CPU Unit* (Cat. No. W495)

Precautions for Correct Use

- Execution of this instruction is continued until processing is completed even if the value of *Execute* changes to FALSE or the execution time exceeds the task period. The value of *Done* changes to TRUE when processing is completed. Use this to confirm normal completion of processing.
- Refer to *Using this Section* on page 2-3 for a timing chart for *Execute*, *Done*, *Busy*, and *Error*.
- Execute the *CIPOpen* or *CIPOpenWithDataSize* instruction to obtain the value for *Handle* before you execute this instruction.
- Always use a variable for the input parameter to pass to *SrcDat*. A building error will occur if a constant is passed.
- If *SrcDat* is an enumeration, you cannot directly pass an enumerator to it. A building error will occur if an enumerator is passed to it directly.
- You can use this instruction only through a built-in EtherNet/IP port on an NY-series Controller or an NJ/NX-series CPU Unit, or through a port on an EtherNet/IP Unit connected to an NJ-series CPU Unit.
- If a variable is written to an OMRON Controller, the variable must be published to the network. Publish the variable to the network in advance.
- You cannot specify an address in memory for CJ-series Units directly to write data. To write specific addresses in memory for CJ-series Units, use an AT specification in advance to assign the memory addresses to a variable.
- You cannot directly specify an address in local memory for CJ-series Units. To write specific addresses in memory for CJ-series Units, use an AT specification in advance to assign the memory addresses to *SrcDat*.
- The characters that can be used in *DstDat* are specified in the following table.

Item	Specification
Maximum number of bytes	127 bytes
Character code	UTF-8
Applicable characters	Alphanumeric characters (not case sensitive), single-byte Katakana, multibyte characters, and '_' (underbars)
Prohibited text strings	<ul style="list-style-type: none"> • Any text string that starts with ASCII characters 0 to 9 (character codes 16#30 to 16#39) • A text string that consists of only a single _ (underbar) ASCII character • Any text string that includes two or more consecutive _ (underbar) ASCII characters • Any text string that starts with an _ (underbar) ASCII character • Any text string that ends with an _ (underbar) ASCII character • Any text string that starts with "P_"

- An error occurs in the following cases. *Error* will change to TRUE.
 - The value of *Size* is outside of the valid range.
 - The text string in *DstDat* is not valid.
 - The value of *Size* exceeds the range of *SrcDat*.
 - A data type that is not supported was specified for *SrcDat*.
 - An error response defined by CIP was returned.
 - The value of *Handle.Handle* is outside of the valid range.
 - More than 32 CIP-related instructions were executed simultaneously.
 - The connection that was established with the *CIPOpen* or *CIPOpenWithDataSize* instruction has timed out.
 - The total of the size in *DstDat* and the value of *SrcDat* exceeded the data size determined by the instruction that established the connection and the data type of the write data.

- For this instruction, expansion error code *ErrorIDEx* gives the CIP message error code. The meanings are as follows:

Value	Error
16#02000000	Normal communications are not possible due to a high load at the remote node.
16#04000000	The specified source variable is one of the following data types and it does not exist on the other Controller. <ul style="list-style-type: none"> Basic data type Enumeration Structure Union Array
16#05000000	The specified source variable is one of the following and it does not exist on the other Controller. <ul style="list-style-type: none"> Enumeration enumerator Structure member Union member Array element
16#08000000	The requested service does not support.
16#0C008010	The specified source variable is being downloaded.
16#0C008011	
16#1F000102	<ul style="list-style-type: none"> The specified destination variable has a Constant attribute, so it cannot be written. The write data does not agree with the number of write elements.
16#1F008007	The inaccessible variable is specified.
16#20008017	The specified destination variable is not an array and the number of elements to write is not 1.
16#20008018	The specified destination variable is an array and the number of elements to write exceeds the number of elements in the array.
16#20008028	<ul style="list-style-type: none"> The specified destination variable is an enumeration and the write data is not the value of an enumerator. The specified destination variable has a Range Specification attribute and the write data is out of range.
16#26000000	The specified destination variable contains only the NULL character.

Sample Programming

Refer to the sample programming that is provided for the CIPOpen instruction (page 2-1018).

CIPSend

The CIPSend instruction sends a class 3 CIP message to a specified device on a CIP network.

Instruction	Name	FB/ FUN	Graphic expression	ST expression
CIPSend	Send Explicit Message Class 3	FB	<pre> graph LR subgraph CIPSend_instance [CIPSend_instance] direction TB subgraph CIPSend_box [CIPSend] direction LR Execute --- Done Handle --- Busy ServiceCode --- Error RqPath --- ErrorID ServiceDat --- ErrorIDEx Size --- RespSize RespServiceDat --- RespServiceDat end end </pre>	CIPSend_instance(Execute, Handle, ServiceCode, RqPath, ServiceDat, Size, RespServiceDat, Done, Busy, Error, ErrorID, ErrorIDEx, RespSize);

Variables

Name	Meaning	I/O	Description	Valid range	Unit	Default
Handle	Handle	Input	Handle obtained with CIPOpen or CIPOpenWithDataSize instruction	---	---	---
ServiceCode	Service code		Service code	Depends on data type.		
RqPath	Request path		Request path	---		
ServiceDat	Service data		Service data to send	Depends on data type.		
Size	Number of elements to send		Number of elements to send			
RespServiceDat	Response data	In-out	Response data	Depends on data type.	---	---
RespSize	Response size	Output	Response data size	Depends on data type.	Bytes	---

* If you omit an input parameter, the default value is not applied. A building error will occur.

	Boolean	Bit strings				Integers								Real numbers	Times, durations, dates, and text strings					
	BOOL	BYTE	WORD	DWORD	LWORD	USINT	UINT	UDINT	ULINT	SINT	INT	DINT	LINT	REAL	LREAL	TIME	DATE	TOD	DT	STRING
Handle	Refer to <i>Function</i> for details on the structure <code>_sCIP_HANDLE</code> .																			
ServiceCode		OK																		
RqPath	Refer to <i>Function</i> for details on the structure <code>_sREQUEST_PATH</code> or <code>_sREQUEST_PATH_EX</code> *1.																			
ServiceDat		OK	OK	OK	OK	OK	OK	OK	OK	OK	OK	OK	OK	OK						
	An array, structure member, or union member can also be specified.																			
Size							OK													
RespService-Dat		OK	OK	OK	OK	OK	OK	OK	OK	OK	OK	OK	OK	OK						
	An array, structure member, or union member can also be specified.																			
RespSize							OK													

*1 A CPU Unit with unit version 1.11 or later and Sysmac Studio version 1.15 or higher are required to specify `_sREQUEST_PATH_EX` type.

Function

The CIPSend instruction sends service data *ServiceDat* for the service specified with service code *ServiceCode* as a class 3 explicit message.

The destination is specified with handle *Handle*.

RqPath specifies the request path.

Size specifies the number of elements to send. If *ServiceDat* is an array, specify the number of elements to send with *Size*. If *ServiceDat* is not an array, always specify 1 for *Size*. If no service data is required, set *Size* to 0.

The response data received later is stored in *RespServiceDat*. The number of bytes of the response data is stored in *RespSize*.

The data type of *Handle* is structure `_sCIP_HANDLE`. The specifications are as follows:

Name	Meaning	Description	Data type	Valid range	Unit	Default
Handle	Handle	Handle	<code>_sCIP_HANDLE</code>	---	---	---
Handle	Handle	Handle	UDINT	Depends on data type.	---	---

The data type of *RqPath* is structure `_sREQUEST_PATH` or `_sREQUEST_PATH_EX`.

Normally, use `_sREQUEST_PATH`. When you want to specify any logical format size, use `_sREQUEST_PATH_EX`. The specifications are as follows:

- `_sREQUEST_PATH` type

Name	Meaning	Description	Data type	Valid range	Unit	Default
RqPath	Request path	Request path	<code>_sREQUEST_PATH</code>	---	---	---
ClassID	Class ID	Class ID	UINT	Depends on data type.	---	0
InstanceID	Instance ID	Instance ID	UINT			FALSE
isAttributeID	Attribute usage	TRUE:Attribute ID used. FALSE:Attribute ID not used.	BOOL			0
AttributeID	Attribute ID	Attribute ID	UINT			

Note The logical format size of each ID in `_sREQUEST_PATH` type is 16 bits.

- `_sREQUEST_PATH_EX` type

Name	Meaning	Description	Data type	Valid range	Unit	Default
RqPath	Request path	Request path	<code>_sREQUEST_PATH_EX</code>	---	---	---
ClassIDLogicalFormat	Class ID logical format	Class ID data size	<code>_eCIP_LOGICAL_FORMAT</code>	Depends on data type.	---	<code>_8BIT</code>
ClassID	Class ID	Class ID	UDINT			0
InstanceIDLogicalFormat	Instance ID logical format	Instance ID data size	<code>_eCIP_LOGICAL_FORMAT</code>			<code>_8BIT</code>
InstanceID	Instance ID	Instance ID	UDINT			0
isAttributeID	Attribute usage	TRUE:Attribute ID used. FALSE:Attribute ID not used.	BOOL			FALSE
AttributeIDLogicalFormat	Attribute ID logical format	Attribute ID data size	<code>_eCIP_LOGICAL_FORMAT</code>			<code>_8BIT</code>
AttributeID	Attribute ID	Attribute ID	UDINT			0

The data type of *ClassIDLogicalFormat*, *InstanceIDLogicalFormat*, and *AttributeIDLogicalFormat* is enumerated type `_eCIP_LOGICAL_FORMAT`.

The meanings of the enumerators of enumerated type `_eCIP_LOGICAL_FORMAT` are as follows:

Enumerator	Meaning
<code>_8BIT</code>	8 bits
<code>_16BIT</code>	16 bits
<code>_32BIT</code>	32 bits

If the value of *ErrorID* is `WORD#16#1C00`, the CIP message error code is stored in *ErrorIDEx*. The meaning and values of *ErrorIDEx* depend on the remote node. Refer to the manual for the remote node.

Sending and Receiving Arrays

If *ServiceDat* or *RespServiceDat* is an array, pass a subscripted array element to it as the parameter.

Maximum Read/Write Data Size

The maximum size of the data that you can read depends on whether the connection was opened with the CIPOpen instruction or the CIPOpenWithDataSize instruction as shown in the following table.

Instruction that opened the connection	Maximum size of data that you can read
CIPOpen	1,990 bytes
CIPOpenWithDataSize	With 8,188*1 as the upper limit, responses returned by the server can be read.

*1 The maximum size is 1,990 for NX1P2 and NJ-series CPU Units.

The maximum size of the data that you can write depends on whether there is a request path attribute and the instruction that established the connection, as given below.

Maximum write data size [bytes] = Base size – Attribute usage

Item in above formula	Meaning
Base size	<ul style="list-style-type: none"> Connection established with the CIPOpen instruction: 1,992 bytes Connection established with the CIPOpenWithDataSize instruction: <i>Data-Size</i> in CIPOpenWithDataSize instruction – 2
Attribute usage*1	Attribute ID used: 14 bytes Attribute ID not used: 10 bytes

*1 With a CPU Unit with unit version 1.10 or earlier or Sysmac Studio version 1.14 or lower, the values are as follows:

Attribute ID used: 12 bytes

Attribute ID not used: 8 bytes

Related System-defined Variables

Name	Meaning	Data type	Description
_EIP_EtnOnlineSta*1	Online	BOOL	This variable indicates when built-in EtherNet/IP port communications can be used. TRUE: Communications are possible. FALSE: Communications are not possible.
_EIP1_EtnOnlineSta*2			
_EIP2_EtnOnlineSta*3			
_EIPIn1_EtnOnlineSta*4			

*1 Use this variable name for an NJ-series CPU Unit.

*2 Use this variable name for port 1 on an NX-series CPU Unit, or for an NY-series Controller.

*3 Use this variable name for port 2 on an NX-series CPU Unit.

*4 Use this variable name for the internal port on an NY-series Controller.

Additional Information

Refer to the following manuals for details on CIP communications.

- NJ/NX-series CPU Unit Built-in EtherNet/IP Port User's Manual* (Cat. No. W506)
- NY-series Industrial Panel PC / Industrial Box PC Built-in EtherNet/IP Port User's Manual* (Cat. No. W563)
- CJ-series EtherNet/IP Units Operation Manual for NJ-series CPU Unit* (Cat. No. W495)

Precautions for Correct Use

- Execution of this instruction is continued until processing is completed even if the value of *Execute* changes to FALSE or the execution time exceeds the task period. The value of *Done* changes to TRUE when processing is completed. Use this to confirm normal completion of processing.
- Refer to *Using this Section* on page 2-3 for a timing chart for *Execute*, *Done*, *Busy*, and *Error*.
- Execute the CIPOpen or CIPOpenWithDataSize instruction to obtain the value for *Handle* before you execute this instruction.
- Always use a variable for the input parameter to pass to *ServiceDat*. A building error will occur if a constant is passed.
- You can use this instruction only through a built-in EtherNet/IP port on an NY-series Controller or an NJ/NX-series CPU Unit, or through a port on an EtherNet/IP Unit connected to an NJ-series CPU Unit.
- If a variable is written to an OMRON Controller, the variable must be published to the network. Publish the variable to the network in advance.
- An error occurs in the following cases. *Error* will change to TRUE.
 - A value that is out of valid range is set for *RqPath.ClassIDLogicalFormat* or *RqPath.AttributeIDLogicalFormat*.
 - A mismatch occurred between the following two variables: the size specified for *RqPath.ClassIDLogicalFormat* and the data size of *RqPath.ClassID*, the size specified for *RqPath.InstanceIDLogicalFormat* and the data size of *RqPath.InstanceID*, or the size specified for *RqPath.AttributeIDLogicalFormat* and the data size of *RqPath.AttributeID*.
 - The value of *Size* exceeds the write data range.
 - The value of *Size* exceeds the range of *ServiceDat*.
 - The value of *RespSize* exceeds the range of *RespServiceDat*.
 - A data type that is not supported was specified for *ServiceDat*.
 - A data type that is not supported was specified for *RespServiceDat*.
 - A variable whose data type is other than *_sREQUEST_PATH* or *_sREQUEST_PATH_EX* is specified for *RqPath*.
 - An error response defined by CIP was returned.
 - The value of *Handle.Handle* is outside of the valid range.
 - More than 32 CIP-related instructions were executed simultaneously.
 - The connection that was established with the CIPOpen or CIPOpenWithDataSize instruction has timed out.
 - The total of the sizes of *RqPath* and *ServiceDat* exceeded the data size determined by the instruction that established the connection.

Sample Programming

Refer to the sample programming that is provided for the CIPOpen instruction (page 2-1018).

CIPClose

The CIPClose instruction closes the CIP class 3 connection to the specified handle.

Instruction	Name	FB/ FUN	Graphic expression	ST expression
CIPClose	Close CIP Class 3 Connection	FB		CIPClose_instance(Execute, Handle, Done, Busy, Error, ErrorID, ErrorIDEx);

Variables

Name	Meaning	I/O	Description	Valid range	Unit	Default
Handle	Handle	Input	Handle obtained with CIPOpen or CIPOpenWithDataSize instruction	---	---	---

	Boolean	Bit strings					Integers							Real numbers	Times, durations, dates, and text strings						
		BOOL	BYTE	WORD	DWORD	LWORD	USINT	UINT	UDINT	ULINT	SINT	INT	DINT		LINT	REAL	LREAL	TIME	DATE	TOD	DT
Handle		Refer to <i>Function</i> for details on the structure <code>_sCIP_HANDLE</code> .																			

Function

The CIPClose instruction closes the CIP class 3 connection specified with the handle *Handle*.

The data type of *Handle* is structure `_sCIP_HANDLE`. The specifications are as follows:

Name	Meaning	Description	Data type	Valid range	Unit	Default
Handle	Handle	Handle	<code>_sCIP_HANDLE</code>	---	---	---
Handle	Handle	Handle	UDINT	Depends on data type.	---	---

The following figure shows a programming example. The CIPClose instruction closes the CIP class 3 connection specified with *Handle* (= `cip_h`).

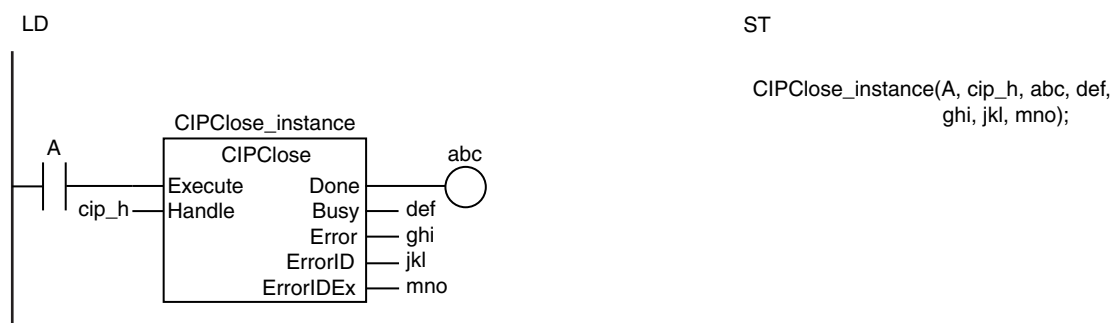

The CIPClose instruction closes the CIP class 3 connection specified with *Handle*.

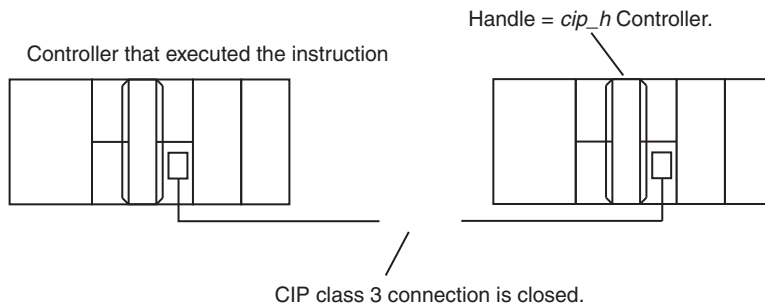

Related System-defined Variables

Name	Meaning	Data type	Description
<u>_EIP_EtnOnlineSta</u> ^{*1}	Online	BOOL	This variable indicates when built-in EtherNet/IP port communications can be used. TRUE: Communications are possible. FALSE: Communications are not possible.
<u>_EIP1_EtnOnlineSta</u> ^{*2}			
<u>_EIP2_EtnOnlineSta</u> ^{*3}			
<u>_EIPIn1_EtnOnlineSta</u> ^{*4}			

*1 Use this variable name for an NJ-series CPU Unit.

*2 Use this variable name for port 1 on an NX-series CPU Unit, or for an NY-series Controller.

*3 Use this variable name for port 2 on an NX-series CPU Unit.

*4 Use this variable name for the internal port on an NY-series Controller.

Additional Information

Refer to the following manuals for details on CIP communications.

- *NJ/NX-series CPU Unit Built-in EtherNet/IP Port User's Manual* (Cat. No. W506)
- *NY-series Industrial Panel PC / Industrial Box PC Built-in EtherNet/IP Port User's Manual* (Cat. No. W563)
- *CJ-series EtherNet/IP Units Operation Manual for NJ-series CPU Unit* (Cat. No. W495)

Precautions for Correct Use

- Execution of this instruction is continued until processing is completed even if the value of *Execute* changes to FALSE or the execution time exceeds the task period. The value of *Done* changes to TRUE when processing is completed. Use this to confirm normal completion of processing.
- Refer to *Using this Section* on page 2-3 for a timing chart for *Execute*, *Done*, *Busy*, and *Error*.
- Specify the handle that was obtained with the CIPOpen or CIPOpenWithDataSize instruction for *Handle*.
- You can use this instruction only through a built-in EtherNet/IP port on an NY-series Controller or an NJ/NX-series CPU Unit, or through a port on an EtherNet/IP Unit connected to an NJ-series CPU Unit.
- This instruction does not use *ErrorIDEx*.
- An error occurs in the following cases. *Error* will change to TRUE.
 - The value of *Handle.Handle* is outside of the valid range.
 - More than 32 CIP-related instructions were executed simultaneously.

Sample Programming

Refer to the sample programming that is provided for the CIPOpen instruction (page 2-1018).

CIPUCMMRead

The CIPUCMMRead instruction uses a UCMM explicit message to read the value of a variable in another Controller on the specified CIP network.

Instruction	Name	FB/ FUN	Graphic expression	ST expression
CIPUCMM Read	Read Variable UCMM Explicit	FB		CIPUCMMRead_instance(Execute, RoutePath, TimeOut, SrcDat, Size, DstDat, Done, Busy, Error, ErrorID, ErrorIDEx, RcvSize);

Variables

Name	Meaning	I/O	Description	Valid range	Unit	Default
RoutePath	Route path	Input	Route path	Depends on data type.	----	---
TimeOut	Timeout time		Timeout time	1 to 65535	0.1 s	20 (2 s)
SrcDat	Source variable name		Name of variable to read in other Controller	Depends on data type.		"
Size	Number of elements to read		Number of elements to read	0 to 496	---	1
DstDat	Read data	In-out	Read data value	Depends on data type.	---	---
RcvSize	Read data size	Output	Read data size	0 to 496	Bytes	---

	Boolean	Bit strings					Integers							Real numbers	Times, durations, dates, and text strings					
	BOOL	BYTE	WORD	DWORD	LWORD	USINT	UINT	UDINT	ULINT	SINT	INT	DINT	LINT	REAL	LREAL	TIME	DATE	TOD	DT	STRING
RoutePath								OK												OK
TimeOut							OK													
SrcDat																				OK
Size							OK													
DstDat	OK	OK	OK	OK	OK	OK	OK	OK	OK	OK	OK	OK	OK	OK	OK	OK	OK	OK	OK	OK
	An enumeration, array, structure, structure member, or union member can also be specified.*																			
RcvSize								OK												

* You cannot specify a STRING array.

Function

The CIPUCMMRead instruction reads the value of the network variable specified with source variable name *SrcDat* from another Controller on a CIP network. The other Controller is specified with route path *RoutePath*.

The read data value is stored in *DstDat*.

Size specifies the number of elements to read. If *SrcDat* is an array, specify the number of elements to read with *Size*. If *SrcDat* is not an array, always specify 1 for *Size*. If the value of *Size* is 0, nothing is read regardless of whether *SrcDat* is an array or not.

When the read operation is completed, the number of bytes of the data that was read is assigned to read data size *RcvSize*. The maximum size of the data that you can read depends on the data type of the variable as follows:

- Structure: 492 bytes
- STRING: 494 bytes
- Other data types: 496 bytes

Timeout specifies the timeout time. If a response does not return within the timeout time, it is assumed that communications failed.

If the value of *ErrorID* is WORD#16#1C00, the CIP message error code is stored in *ErrorIDEx*.

In the following example, the value of variable *abc* in the remote Controller is read and stored in the variable *def* in the local Controller. The number of elements to read *Size* is UINT#1. The data type of *abc* and *def* is SINT. The size of SINT data is one byte, so the value of the read data size *vwx* is UINT#1.

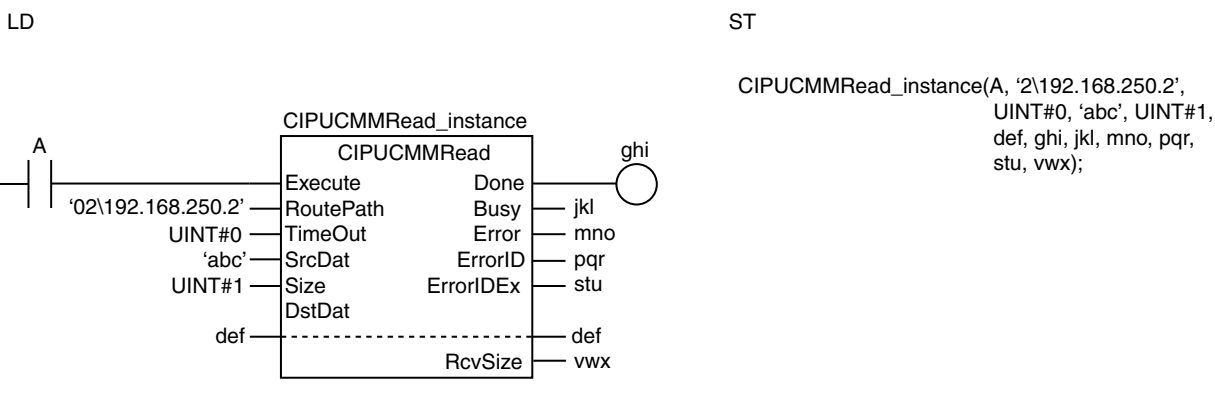

Value of variable *SrcDat* in remote Controller on the CIP network specified by the route path *RoutePath* is assigned to variable *DstDat* in local Controller. *Size* specifies the number of elements to read. The size of data that was read is assigned to *RcvSize*.

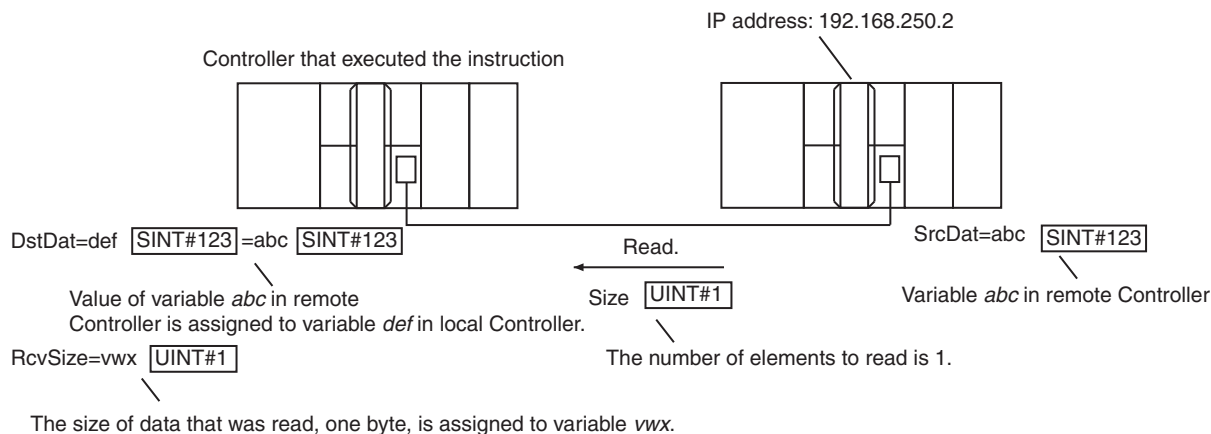

Reading Arrays

To read array data, pass a subscripted array element to *SrcDat* as the parameter. Also pass a subscripted array element to *DstDat* as the parameter.

The following example reads the four array variable elements *abc[3]* to *abc[6]* from the remote Controller and stores the results in array variable elements *def[10]* to *def[13]* in the local Controller. The data type of *abc* and *def* is INT. The size of INT data is two bytes, so the value of the read data size *vwX* is UINT#8.

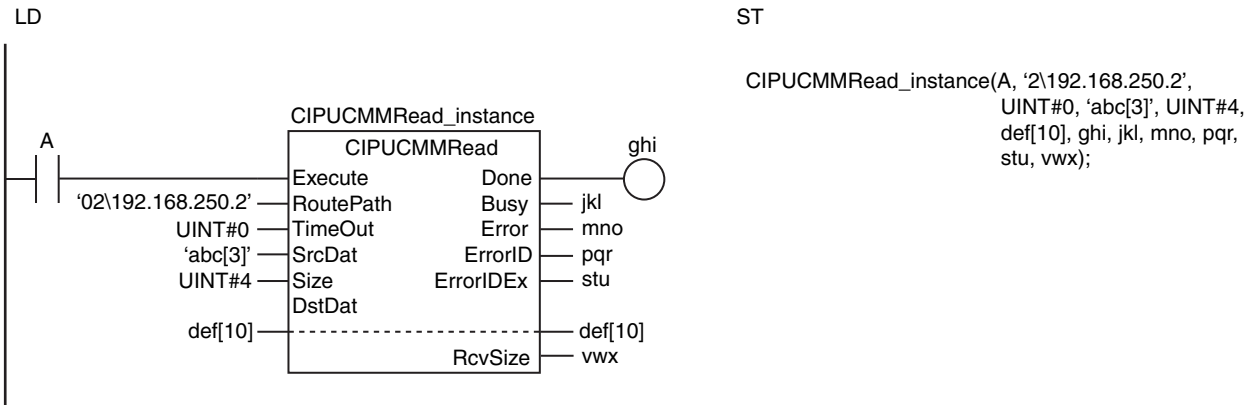

Values of array variable elements *abc[3]* to *abc[6]* in remote Controller are assigned to array variable elements *def[10]* to *def[13]* in local Controller.

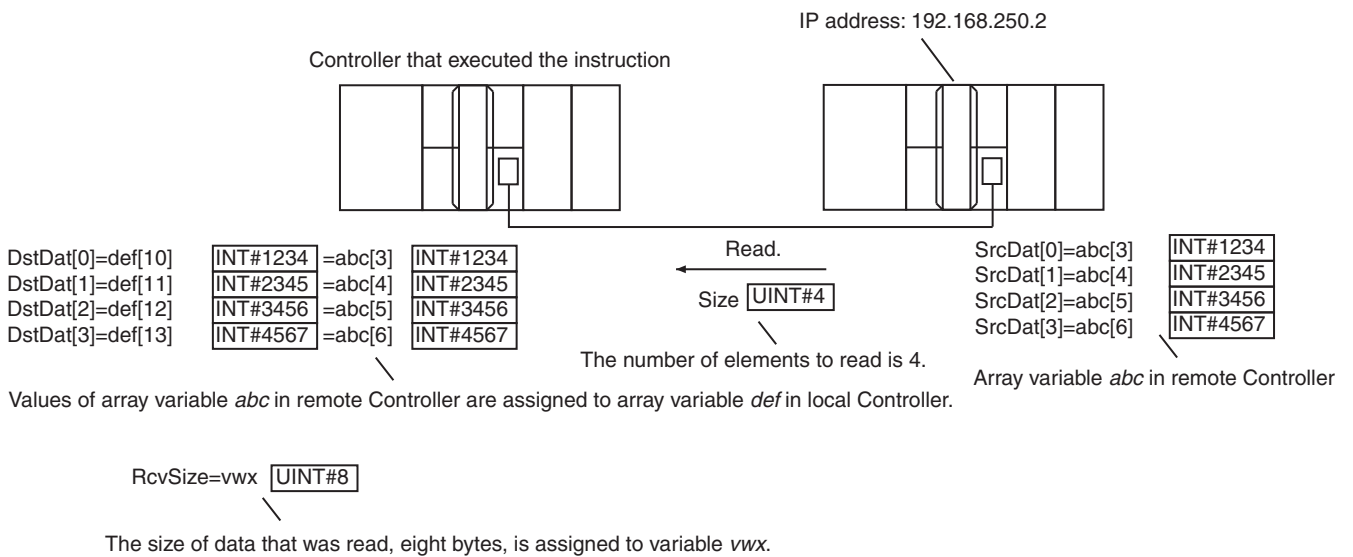

Related System-defined Variables

Name	Meaning	Data type	Description
<u>_EIP_EtnOnlineSta</u> *1	Online	BOOL	This variable indicates when built-in EtherNet/IP port communications can be used. TRUE: Communications are possible. FALSE: Communications are not possible.
<u>_EIP1_EtnOnlineSta</u> *2			
<u>_EIP2_EtnOnlineSta</u> *3			
<u>_EIPIn1_EtnOnlineSta</u> *4			

*1 Use this variable name for an NJ-series CPU Unit.

*2 Use this variable name for port 1 on an NX-series CPU Unit, or for an NY-series Controller.

*3 Use this variable name for port 2 on an NX-series CPU Unit.

*4 Use this variable name for the internal port on an NY-series Controller.

Additional Information

Refer to the following manuals for details on CIP communications.

- *NJ/NX-series CPU Unit Built-in EtherNet/IP Port User's Manual* (Cat. No. W506)
- *NY-series Industrial Panel PC / Industrial Box PC Built-in EtherNet/IP Port User's Manual* (Cat. No. W563)
- *CJ-series EtherNet/IP Units Operation Manual for NJ-series CPU Unit* (Cat. No. W495)

Precautions for Correct Use

- Execution of this instruction is continued until processing is completed even if the value of *Execute* changes to FALSE or the execution time exceeds the task period. The value of *Done* changes to TRUE when processing is completed. Use this to confirm normal completion of processing.
- Refer to *Using this Section* on page 2-3 for a timing chart for *Execute*, *Done*, *Busy*, and *Error*.
- This instruction can be used only for the built-in EtherNet/IP ports on NJ/NX-series CPU Units and NY-series Controllers.
- If a variable is read from an OMRON Controller, the variable must be published to the network. Publish the variable to the network in advance.
- You cannot specify an address in memory for CJ-series Units directly to read data. To read specific addresses in memory for CJ-series Units, use an AT specification in advance to assign the memory addresses to a variable.
- You cannot specify an address in local memory for CJ-series Units directly to store data. To store data in specific addresses in memory for CJ-series Units, use an AT specification in advance to assign the memory addresses to *DstDat*.
- The characters that can be used in *SrcDat* are specified in the following table.

Item	Specification
Maximum number of bytes	127 bytes
Character code	UTF-8
Applicable characters	Alphanumeric characters (not case sensitive), single-byte Katakana, multibyte characters, and '_' (underbars)
Prohibited text strings	<ul style="list-style-type: none"> • Any text string that starts with ASCII characters 0 to 9 (character codes 16#30 to 16#39) • A text string that consists of only a single _ (underbar) ASCII character • Any text string that includes two or more consecutive _ (underbar) ASCII characters • Any text string that starts with an _ (underbar) ASCII character • Any text string that ends with an _ (underbar) ASCII character • Any text string that starts with "P_"

- An error occurs in the following cases. *Error* will change to TRUE.
 - The value of *TimeOut* is outside of the valid range.
 - The value of *Size* is outside of the valid range.
 - The text string in *SrcDat* is not valid.
 - The data type of the value that was read does not agree with the data type of *DstDat*.
 - The size of data that was read exceeds the range of *DstDat*.
 - A data type that is not supported was specified for *DstDat*.
 - An error response defined by CIP was returned.
 - The text string in *RoutePath* is not valid.
 - More than 32 CIP-related instructions were executed simultaneously.
 - A response was not received even though the timeout time was exceeded.

- There is a setting error for the local IP address.
 - The instruction was executed when there was a BOOTP server error.
 - A duplicated IP error occurred.
- For this instruction, expansion error code *ErrorIDEx* gives the CIP message error code. The meanings are as follows:

Value	Error
16#02000000	Normal communications are not possible due to a high load at the remote node.
16#04000000	The specified source variable is one of the following data types and it does not exist on the other Controller. <ul style="list-style-type: none"> • Basic data type • Enumeration • Structure • Union • Array
16#05000000	The specified source variable is one of the following and it does not exist on the other Controller. <ul style="list-style-type: none"> • Enumeration enumerator • Structure member • Union member • Array element
16#08000000	The requested service does not support.
16#0C008010	The specified source variable is being downloaded.
16#0C008011	
16#11000000	The value of Size is exceeds the data size that can currently be read.
16#1F000102	The variable to read is a variable that is not possible to read.
16#1F008007	The inaccessible variable is specified.
16#20008017	The specified source variable is not an array and the number of elements to read is not 1.
16#20008018	The specified source variable is an array and the number of elements to read exceeds the number of elements in the array.
16#26000000	The specified destination variable contains only the NULL character.

Sample Programming

Refer to the sample programming that is provided for the CIPUCMMSend instruction (page 2-1063).

CIPUCMMWrite

The CIPUCMMWrite instruction uses a UCMM explicit message to write the value of a variable in another Controller on a CIP network.

Instruction	Name	FB/ FUN	Graphic expression	ST expression
CIPUCMM Write	Write Variable UCMM Explicit	FB		CIPUCMMWrite_instance(Execute, RoutePath, TimeOut, DstDat, Size, SrcDat, Done, Busy, Error, ErrorID, ErrorIDEx);

Variables

Name	Meaning	I/O	Description	Valid range	Unit	Default
RoutePath	Route path	Input	Route path	Depends on data type.	---	---
TimeOut	Timeout time		Timeout time	1 to 65535	0.1 s	20 (2 s)
DstDat	Destination variable name		Name of variable to write in another Controller	Depends on data type.	---	"
Size	Number of elements to write		Number of elements to write	0 to 488		1
SrcDat	Source data		Data value to write	Depends on data type.		*

* If you omit an input parameter, the default value is not applied. A building error will occur.

	Boolean	Bit strings					Integers							Real numbers		Times, durations, dates, and text strings					
	BOOL	BYTE	WORD	DWORD	LWORD	USINT	UINT	UDINT	ULINT	SINT	INT	DINT	LINT	REAL	LREAL	TIME	DATE	TOD	DT	STRING	
RoutePath																				OK	
TimeOut							OK														
DstDat																				OK	
Size							OK														
SrcDat	OK	OK	OK	OK	OK	OK	OK	OK	OK	OK	OK	OK	OK	OK	OK	OK	OK	OK	OK	OK	
	An enumeration, array*, structure, structure member, or union member can also be specified.																				

* You cannot specify a STRING array.

Function

The CIPUCMMWrite instruction writes the value of the network variable specified with destination variable name *DstDat* at another Controller on a CIP network. The other Controller is specified with route path *RoutePath*.

The content of source data *SrcDat* is written.

Size specifies the number of elements to write. If *DstDat* is an array, specify the number of elements to write with *Size*. If *DstDat* is not an array, always specify 1 for *Size*. If the value of *Size* is 0, nothing is written regardless of whether *DstDat* is an array or not.

TimeOut specifies the timeout time. If a response does not return within the timeout time, it is assumed that communications failed.

If the value of *ErrorID* is WORD#16#1C00, the CIP message error code is stored in *ErrorIDEx*.

The following example writes the value of variable *def* from the local Controller to the variable *abc* in the remote Controller. The number of elements to write *Size* is UINT#1.

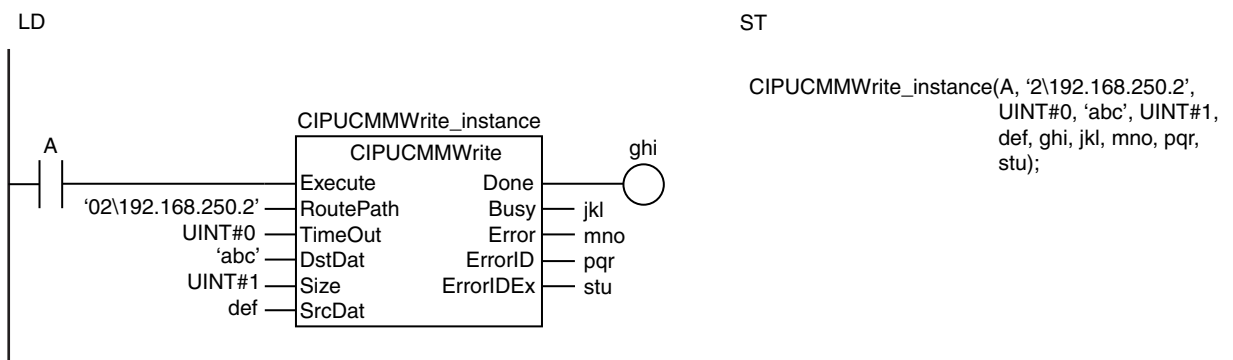

Value of variable *SrcDat* in local Controller is assigned to variable *DstDat* in remote Controller on the CIP network specified by the route path *RoutePath*. *Size* specifies the number of elements to write.

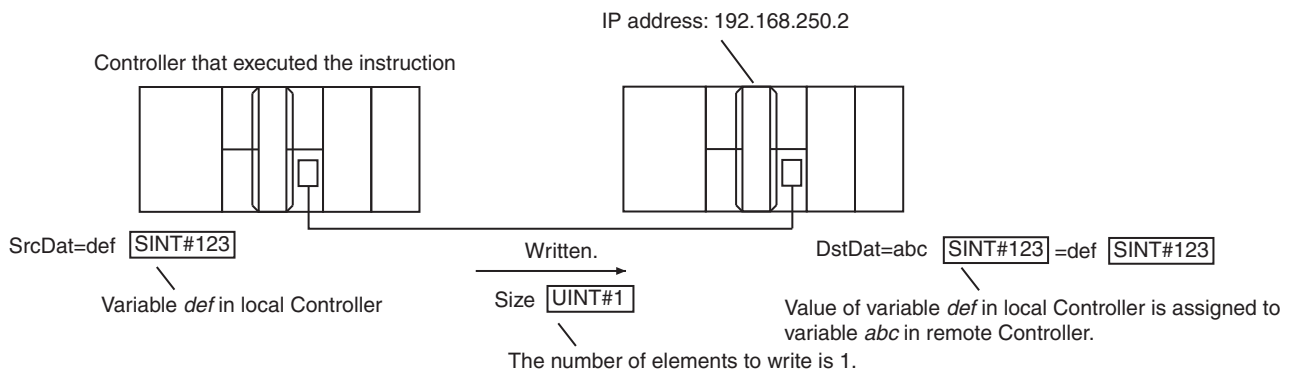

Writing Arrays

To write array data, pass a subscripted array element to *DstDat* as the parameter. Also pass a subscripted array element to *SrcDat* as the parameter.

The following example stores the contents of array variable elements *def[10]* to *def[13]* in the four array variable elements *abc[3]* to *abc[6]*.

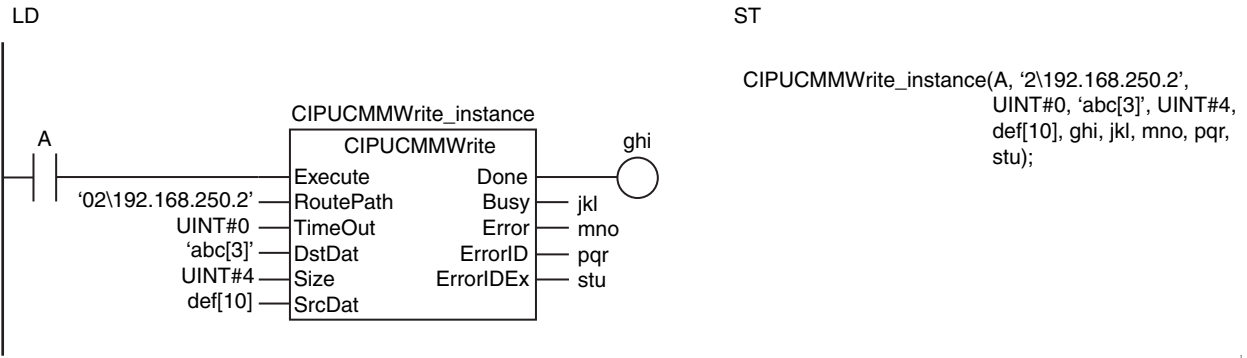

Values of array variable elements *def[10]* to *def[13]* in local Controller are assigned to array variable elements *abc[3]* to *abc[6]* in remote Controller.

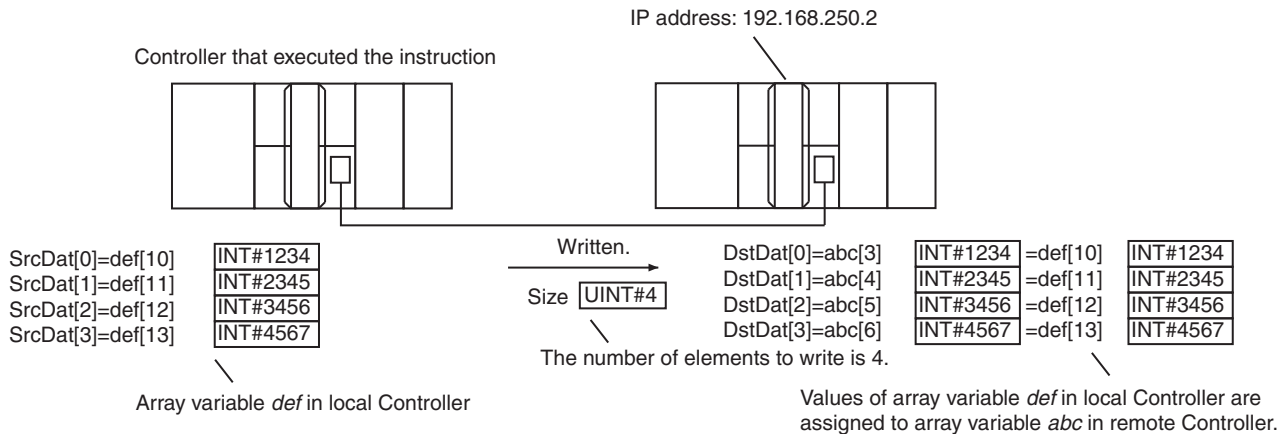

Maximum Write Data Size

The maximum size of the data that you can write depends on the data type and variable name that are specified for *DstDat* and the route path, as given in the following table.

Maximum write data size [bytes] = Base size – Size of variable name of *DstDat* – Path information size

Item in above formula	Meaning
Base size	<ul style="list-style-type: none"> Data type of variable specified for <i>DstDat</i> is a structure: 492 bytes Data type of variable specified for <i>DstDat</i> is a STRING: 494 bytes Other data types: 496 bytes

Item in above formula	Meaning
Size of variable name of <i>DstDat</i>	<ul style="list-style-type: none"> • The size of the variable name is calculated as the total bytes for the ASCII characters in all structure levels plus two times the number of levels. • If the number of bytes of ASCII characters in a level is an odd number, add 1. • If a level in the structure is an array, add four times the number of dimensions in the array. • Periods and commas in the structure and arrays are not included in the variable name size. <p>Example 1: When the Variable Name of <i>DstDat</i> Is <i>aaa.bbbbb[1,2,3].cc</i></p> <ul style="list-style-type: none"> • The text string “aaa” in the first level is 3 bytes. It is an odd number, so 1 is added to make 4 bytes. • The text string “bbbb[1,2,3]” in the second level is 5 bytes. It is an odd number, so 1 is added to make 6 bytes. • Also <i>bbbb[1,2,3]</i> is a three-dimensional array, so 3 times 4, or 12, is added to make 18 bytes. • The text string “cc” in the third level is 2 bytes. It is an even number, so 2 bytes is used in the calculation. • If we add the number of levels 3 times 2, or 6, to 4 bytes for the first level, 18 bytes for the second level, and 2 bytes for the third level, the size of the variable name come to 30 bytes. <p>Example 2: When the Variable Name of <i>DstDat</i> Is <i>val</i></p> <ul style="list-style-type: none"> • The text string “val” in the first level is 3 bytes. It is an odd number, so 1 is added to make 4 bytes. • If we then add the number of levels 1 times 2, or 2, the size of the variable name is 6 bytes. <p>Example 3: When the Variable Name of <i>DstDat</i> Is <i>array[8]</i>.</p> <ul style="list-style-type: none"> • The text string “array” in the first level is 5 bytes. It is an odd number, so 1 is added to make 6 bytes. • It is a one-dimensional array. Therefore, 1 times 4, or 4, is added. • If we then add the number of levels 1 times 2, or 2, the size of the variable name is 12 bytes.

Item in above formula	Meaning
Path information size	<ul style="list-style-type: none"> • If there are no hops, the path information size is 0 bytes.* • If there are hops, the path information size is the route path size plus 12 bytes. • The route path size is the bytes size of the ASCII characters in the route path. • However, the following precautions apply. <ul style="list-style-type: none"> • If the address portion starts with “#”, calculate the network and address portions as a total of 2 bytes. • If the address portion does not start with “#”, calculate the network portion as 2 bytes. • If the address portion does not start with “#” and the number of bytes in the ASCII characters for the address portion is an odd number, add 1 byte. • Do not include the level separator, “\”, between levels of the route path in the route path size. • Do not include the first hop in the route path size. <p>Example 1: When the Route Path Is 01\#11\02\192.168.250.2\01\#01</p> <ul style="list-style-type: none"> • The first hop in the route path size is not included, so ignore ‘01\#11’ at the start of the path. • The network type is ‘02’, so use 2 bytes in the calculation. • The address portion is ‘192.168.250.2’, so use 13 bytes in the calculation. It is an odd number, so 1 is added to make 14 bytes. • For the following ‘01\#01’, the address portion starts with “#”, so the network and address portions are calculated as a total of 2 bytes. • If you add all of the above sizes, the size of the route path is 18 bytes. • If we then add 12 bytes to the route path size, the path information size is 30 bytes. <p>Example 2: When the Route Path Is 02\192.168.250.2\01\#00</p> <ul style="list-style-type: none"> • The first hop in the route path size is not included, so ignore ‘02\192.168.250.2’ at the start of the path. • For the following ‘01\#01’, the address portion starts with “#”, so the network and address portions are calculated as a total of 2 bytes. • Therefore, the size of the route path is 2 bytes. • If we then add 12 bytes to the route path size, the path information size is 14 bytes. <p>Example 3: When the Route Path Is 02\192.168.250.2</p> <ul style="list-style-type: none"> • If there are no hops, the path information size is 0 bytes.

* A hop is routing between the sending node and receiving node. For example, if the route path is 02\192.168.250.2\01\#00, the message is first routed to the node with an IP address of 192.168.250.2 to send the message to unit address 00. This involves one hop.

Related System-defined Variables

Name	Meaning	Data type	Description
_EIP_EtnOnlineSta*1	Online	BOOL	This variable indicates when built-in EtherNet/IP port communications can be used. TRUE: Communications are possible. FALSE: Communications are not possible.
_EIP1_EtnOnlineSta*2			
_EIP2_EtnOnlineSta*3			
_EIPIn1_EtnOnlineSta*4			

*1 Use this variable name for an NJ-series CPU Unit.

*2 Use this variable name for port 1 on an NX-series CPU Unit, or for an NY-series Controller.

*3 Use this variable name for port 2 on an NX-series CPU Unit.

*4 Use this variable name for the internal port on an NY-series Controller.

Additional Information

Refer to the following manuals for details on CIP communications.

- *NJ/NX-series CPU Unit Built-in EtherNet/IP Port User's Manual* (Cat. No. W506)
- *NY-series Industrial Panel PC / Industrial Box PC Built-in EtherNet/IP Port User's Manual* (Cat. No. W563)
- *CJ-series EtherNet/IP Units Operation Manual for NJ-series CPU Unit* (Cat. No. W495)

Precautions for Correct Use

- Execution of this instruction is continued until processing is completed even if the value of *Execute* changes to FALSE or the execution time exceeds the task period. The value of *Done* changes to TRUE when processing is completed. Use this to confirm normal completion of processing.
- Refer to *Using this Section* on page 2-3 for a timing chart for *Execute*, *Done*, *Busy*, and *Error*.
- Always use a variable for the input parameter to pass to *SrcDat*. A building error will occur if a constant is passed.
- If *SrcDat* is an enumeration, you cannot directly pass an enumerator to it. A building error will occur if an enumerator is passed to it directly.
- You can use this instruction only through an NJ/NX-series CPU Unit, through a built-in EtherNet/IP port on an NY-series Controller, or through an EtherNet/IP Unit connected to an NJ-series CPU Unit.
- If a variable is written to an OMRON Controller, the variable must be published to the network. Publish the variable to the network in advance.
- You cannot specify an address in memory for CJ-series Units directly to write data. To write specific addresses in memory for CJ-series Units, use an AT specification in advance to assign the memory addresses to a variable.
- You cannot directly specify an address in local memory for CJ-series Units. To write specific addresses in memory for CJ-series Units, use an AT specification in advance to assign the memory addresses to *SrcDat*.
- The characters that can be used in *DstDat* are specified in the following table.

Item	Specification
Maximum number of bytes	127 bytes
Character code	UTF-8
Applicable characters	Alphanumeric characters (not case sensitive), single-byte Katakana, multibyte characters, and '_' (underbars)
Prohibited text strings	<ul style="list-style-type: none"> • Any text string that starts with ASCII characters 0 to 9 (character codes 16#30 to 16#39) • A text string that consists of only a single _ (underbar) ASCII character • Any text string that includes two or more consecutive _ (underbar) ASCII characters • Any text string that starts with an _ (underbar) ASCII character • Any text string that ends with an _ (underbar) ASCII character • Any text string that starts with "P_"

- An error occurs in the following cases. *Error* will change to TRUE.
 - The value of *TimeOut* is outside of the valid range.
 - The value of *Size* is outside of the valid range.
 - The text string in *DstDat* is not valid.
 - The value of *Size* exceeds the range of *SrcDat*.
 - A data type that is not supported was specified for *SrcDat*.

- An error response defined by CIP was returned.
 - The text string in *RoutePath* is not valid.
 - More than 32 CIP-related instructions were executed simultaneously.
 - A response was not received even though the timeout time was exceeded.
 - There is a setting error for the local IP address.
 - A duplicated IP error occurred.
- For this instruction, expansion error code *ErrorIDEx* gives the CIP message error code. The meanings are as follows:

Value	Error
16#02000000	Normal communications are not possible due to a high load at the remote node.
16#04000000	The specified source variable is one of the following data types and it does not exist on the other Controller. <ul style="list-style-type: none"> • Basic data type • Enumeration • Structure • Union • Array
16#05000000	The specified source variable is one of the following and it does not exist on the other Controller. <ul style="list-style-type: none"> • Enumeration enumerator • Structure member • Union member • Array element
16#08000000	The requested service does not support.
16#0C008010	The specified destination variable is being downloaded.
16#0C008011	
16#1F00102	The specified destination variable has a Constant attribute, so it cannot be written.
16#1F008007	The inaccessible variable is specified.
16#20008017	The specified destination variable is not an array and the number of elements to write is not 1.
16#20008018	The specified destination variable is an array and the number of elements to write exceeds the number of elements in the array.
16#20008028	<ul style="list-style-type: none"> • The specified destination variable is an enumeration and the write data is not the value of an enumerator. • The specified destination variable has a Range Specification attribute and the write data is out of range.
16#26000000	The specified destination variable name is only the NULL character.

Sample Programming

Refer to the sample programming that is provided for the CIPUCMMSend instruction (page 2-1063).

CIPUCMMSend

The CIPUCMMSend instruction sends a UCMM CIP message to a specified device on a CIP network.

Instruction	Name	FB/ FUN	Graphic expression	ST expression
CIPUCMM Send	Send Explicit Message UCMM	FB		CIPUCMMSend_instance(Execute, RoutePath, TimeOut, ServiceCode, RqPath, ServiceDat, Size, RespServiceDat, Done, Busy, Error, ErrorID, ErrorIDEx, RespSize);

Variables

Name	Meaning	I/O	Description	Valid range	Unit	Default
RoutePath	Route path	Input	Route path	Depends on data type.	---	---
TimeOut	Timeout time		Timeout time	1 to 65535	0.1 s	20 (2.0 s)
ServiceCode	Service code		Service code	Depends on data type.	---	---
RqPath	Request path		Request path	---	---	*
ServiceDat	Command data		Data to send	Depends on data type.	---	1
Size	Number of elements to send		Number of elements to send	Depends on data type.		
RespServiceDat	Response data	In-out	Response data	Depends on data type.	---	---
RespSize	Response size	Output	Response data size	Depends on data type.	Bytes	---

* If you omit an input parameter, the default value is not applied. A building error will occur.

	Boolean	Bit strings				Integers							Real numbers		Times, durations, dates, and text strings					
	BOOL	BYTE	WORD	DWORD	LWORD	USINT	UINT	UDINT	ULINT	SINT	INT	DINT	LINT	REAL	LREAL	TIME	DATE	TOD	DT	STRING
RoutePath																				OK
TimeOut							OK													
Service Code		OK																		
ReqPath	Refer to <i>Function</i> for details on the structure <code>_sREQUEST_PATH</code> or <code>_sREQUEST_PATH_EX</code> *1.																			
ServiceDat		OK	OK	OK	OK	OK	OK	OK	OK	OK	OK	OK	OK	OK						
	An array, structure member, or union member can also be specified.																			
Size							OK													

	Boolean	Bit strings					Integers							Real numbers		Times, durations, dates, and text strings				
	BOOL	BYTE	WORD	DWORD	LWORD	USINT	UINT	UDINT	ULINT	SINT	INT	DINT	LINT	REAL	LREAL	TIME	DATE	TOD	DT	STRING
RespServiceDat		OK	OK	OK	OK	OK	OK	OK	OK	OK	OK	OK	OK	OK						
	An array, structure member, or union member can also be specified.																			
RespSize							OK													

*1 A CPU Unit with unit version 1.11 or later and Sysmac Studio version 1.15 or higher are required to specify `_sREQUEST_PATH_EX` type.

Function

The CIPUCMMSend instruction sends command data *ServiceDat* for the service specified with service code *ServiceCode* as a UCMM explicit message.

The destination is specified with route path *RoutePath*.

RqPath specifies the request path.

Size specifies the number of elements to send. If *ServiceDat* is an array, specify the number of elements to send with *Size*. If *ServiceDat* is not an array, always specify 1 for *Size*. If no service data is required, set *Size* to 0.

The response data received later is stored in *RespServiceDat*. The number of bytes of the response data is stored in *RespSize*.

TimeOut specifies the timeout time. If a response does not return within the timeout time, it is assumed that communications failed.

The data type of *RqPath* is structure `_sREQUEST_PATH` or `_sREQUEST_PATH_EX`.

Normally, use `_sREQUEST_PATH`. When you want to specify the logical format size, use `_sREQUEST_PATH_EX`. The specifications are as follows:

- `_sREQUEST_PATH` type

Name	Meaning	Description	Data type	Valid range	Unit	Default
RqPath	Request path	Request path	<code>_sREQUEST_PATH</code>	---	---	---
ClassID	Class ID	Class ID	UINT	Depends on data type.	---	0
InstanceID	Instance ID	Instance ID	UINT			FALSE
isAttributeID	Attribute usage	TRUE:Attribute ID used. FALSE:Attribute ID not used.	BOOL			0
AttributeID	Attribute ID	Attribute ID	UINT			

Note The logical format size of each ID in `_sREQUEST_PATH` type is 16 bits.

- `_sREQUEST_PATH_EX` type

Name	Meaning	Description	Data type	Valid range	Unit	Default
RqPath	Request path	Request path	<code>_sREQUEST_PATH_EX</code>	---	---	---
ClassIDLogicalFormat	Class ID logical format	Class ID data size	<code>_eCIP_LOGICAL_FORMAT</code>	Depends on data type.	---	_8BIT
ClassID	Class ID	Class ID	UDINT			0
InstanceIDLogicalFormat	Instance ID logical format	Instance ID data size	<code>_eCIP_LOGICAL_FORMAT</code>			_8BIT
InstanceID	Instance ID	Instance ID	UDINT			0
isAttributeID	Attribute usage	TRUE:Attribute ID used. FALSE:Attribute ID not used.	BOOL			FALSE
AttributeIDLogicalFormat	Attribute ID logical format	Attribute ID data size	<code>_eCIP_LOGICAL_FORMAT</code>			_8BIT
AttributeID	Attribute ID	Attribute ID	UDINT			0

The data type of *ClassIDLogicalFormat*, *InstanceIDLogicalFormat*, and *AttributeIDLogicalFormat* is enumerated type `_eCIP_LOGICAL_FORMAT`.

The meanings of the enumerators of enumerated type `_eCIP_LOGICAL_FORMAT` are as follows:

Enumerator	Meaning
<code>_8BIT</code>	8 bits
<code>_16BIT</code>	16 bits
<code>_32BIT</code>	32 bits

If the value of *ErrorID* is `WORD#16#1C00`, the CIP message error code is stored in *ErrorIDEx*. The meaning and values of *ErrorIDEx* depend on the remote node. Refer to the manual for the remote node.

Sending and Receiving Arrays

If *ServiceDat* or *RespServiceDat* is an array, pass a subscripted array element to it as the parameter.

Maximum Read/Write Data Size

You can read a maximum of 492 bytes of data. The maximum size of the data that you can write depends on whether there is a request path attribute and the route path that is used, as given below.

Maximum write data size [bytes] = Base size – Attribute usage – Path information size

Item in above formula	Meaning
Base size	500 bytes
Attribute usage*1	Attribute ID used: 14 bytes Attribute ID not used: 10 bytes

Item in above formula	Meaning
Path information size	<ul style="list-style-type: none"> • If there are no hops, the path information size is 0 bytes.*2 • If there are hops, the path information size is the route path size plus 12 bytes. • The route path size is the bytes size of the ASCII characters in the route path. • However, the following precautions apply. <ul style="list-style-type: none"> • If the address portion starts with “#”, calculate the network and address portions as a total of 2 bytes. • If the address portion does not start with “#”, calculate the network portion as 2 bytes. • If the address portion does not start with “#” and the number of bytes in the ASCII characters for the address portion is an odd number, add 1 byte. • Do not include the level separator, “\”, between levels of the route path in the route path size. • Do not include the first hop in the route path size. <p>Example 1: When the Route Path Is 01\#11\02\192.168.250.2\01\#01</p> <ul style="list-style-type: none"> • The first hop in the route path size is not included, so ignore ‘01\#11’ at the start of the path. • The network type is ‘02’, so use 2 bytes in the calculation. • The address portion is ‘192.168.250.2’, so use 13 bytes in the calculation. It is an odd number, so 1 is added to make 14 bytes. • For the following ‘01\#01’, the address portion starts with “#”, so the network and address portions are calculated as a total of 2 bytes. • If you add all of the above sizes, the size of the route path is 18 bytes. • If we then add 12 bytes to the route path size, the path information size is 30 bytes. <p>Example 2: When the Route Path Is 02\192.168.250.2\01\#00</p> <ul style="list-style-type: none"> • The first hop in the route path size is not included, so ignore ‘02\192.168.250.2’ at the start of the path. • For the following ‘01\#01’, the address portion starts with “#”, so the network and address portions are calculated as a total of 2 bytes. • Therefore, the size of the route path is 2 bytes. • If we then add 12 bytes to the route path size, the path information size is 14 bytes. <p>Example 3: When the Route Path Is 02\192.168.250.2</p> <ul style="list-style-type: none"> • If there are no hops, the path information size is 0 bytes.

*1 With a CPU Unit with unit version 1.10 or earlier or Sysmac Studio version 1.14 or lower, the values are as follows:

Attribute ID used: 12 bytes

Attribute ID not used: 8 bytes

*2 A hop is routing between the sending node and receiving node. For example, if the route path is 02\192.168.250.2\01\#00, the message is first routed to the node with an IP address of 192.168.250.2 to send the message to unit address 00. This involves one hop.

Related System-defined Variables

Name	Meaning	Data type	Description
<code>_EIP_EtnOnlineSta</code> *1	Online	BOOL	This variable indicates when built-in EtherNet/IP port communications can be used. TRUE: Communications are possible. FALSE: Communications are not possible.
<code>_EIP1_EtnOnlineSta</code> *2			
<code>_EIP2_EtnOnlineSta</code> *3			
<code>_EIPIn1_EtnOnlineSta</code> *4			

*1 Use this variable name for an NJ-series CPU Unit.

*2 Use this variable name for port 1 on an NX-series CPU Unit, or for an NY-series Controller.

*3 Use this variable name for port 2 on an NX-series CPU Unit.

*4 Use this variable name for the internal port on an NY-series Controller.

Additional Information

Refer to the following manuals for details on CIP communications.

- *NJ/NX-series CPU Unit Built-in EtherNet/IP Port User's Manual* (Cat. No. W506)
- *NY-series Industrial Panel PC / Industrial Box PC Built-in EtherNet/IP Port User's Manual* (Cat. No. W563)
- *CJ-series EtherNet/IP Units Operation Manual for NJ-series CPU Unit* (Cat. No. W495)

Precautions for Correct Use

- Execution of this instruction is continued until processing is completed even if the value of *Execute* changes to FALSE or the execution time exceeds the task period. The value of *Done* changes to TRUE when processing is completed. Use this to confirm normal completion of processing.
- Refer to *Using this Section* on page 2-3 for a timing chart for *Execute*, *Done*, *Busy*, and *Error*.
- Always use a variable for the input parameter to pass to *ServiceDat*. A building error will occur if a constant is passed.
- You can use this instruction only through a built-in EtherNet/IP port on an NY-series Controller or an NJ/NX-series CPU Unit, or through a port on an EtherNet/IP Unit connected to an NJ-series CPU Unit.
- If a variable is written to an OMRON Controller, the variable must be published to the network. Publish the variable to the network in advance.
- An error occurs in the following cases. *Error* will change to TRUE.
 - A value that is out of valid range is set for *RqPath.ClassIDLogicalFormat* or *RqPath.AttributeIDLogicalFormat*.
 - A mismatch occurred between the following two variables: the size specified for *RqPath.ClassIDLogicalFormat* and the data size of *RqPath.ClassID*, the size specified for *RqPath.InstanceIDLogicalFormat* and the data size of *RqPath.InstanceID*, or the size specified for *RqPath.AttributeIDLogicalFormat* and the data size of *RqPath.AttributeID*.
 - The value of *TimeOut* is outside of the valid range.
 - The value of *Size* exceeds the write data range.
 - The value of *Size* exceeds the range of *ServiceDat*.
 - The value of *RespSize* exceeds the range of *RespServiceDat*.
 - A data type that is not supported was specified for *ServiceDat*.
 - A data type that is not supported was specified for *RespServiceDat*.
 - A variable whose data type is other than `_sREQUEST_PATH` or `_sREQUEST_PATH_EX` is specified for *RqPath*.
 - There is a setting error for the local IP address.

- A duplicated IP error occurred.
- The instruction was executed when there was a BOOTP server error.
- An error response defined by CIP was returned.
- The text string in *RoutePath* is not valid.
- More than 32 CIP-related instructions were executed simultaneously.
- A response was not received even though the timeout time was exceeded.

Sample Programming

This sample uses CIP UCMM messages to write a variable, read a variable, and send a message. The Controllers are connected to an EtherNet/IP network. The IP address of the remote node is 192.168.250.2.

The following procedure is used.

- 1** The CIPUCMMWrite instruction is used to write the value of a variable at a remote node. The variable name at the remote node is *WritingDat* and the contents of the *WriteDat* is written to it. *WritingDat* must be defined as a global variable at the remote node and the Network Publish attribute must be set.
- 2** The CIPUCMMRead instruction is used to read the value of a variable at a remote node. The value of the variable *OriginalDat* at the other node is read and the read value is stored in the *ReadDat* variable. *OriginalDat* must be defined as a global variable at the remote node and the Network Publish attribute must be set.
- 3** The CIPUCMMSend instruction is used to send an explicit message to a remote node. The contents of the message is to read identity information (product name). The class ID, instance ID, attribute ID, and service code are as follows: The response data is stored in the *ResDat* variable.

Item	Value
Class ID	1
Instance ID	1
Attribute ID	7
Service code	16#0E

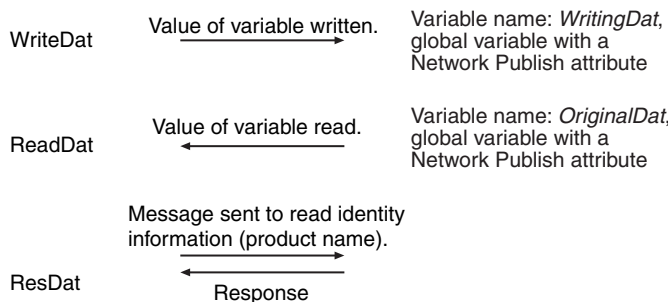
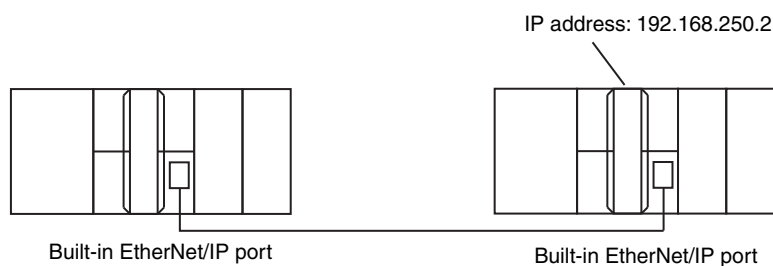

LD

Variable	Data type	Initial value	Comment
OperatingEnd	BOOL	FALSE	Processing completed
Trigger	BOOL	FALSE	Execution condition
Operating	BOOL	FALSE	Processing
WriteDat	INT	1234	Write data
ReadDat	INT	0	Read data
ReqPath	_sREQUEST_PATH	(ClassID:=0, InstanceID:=0, isAttributeID:=FALSE, AttributeID:=0)	Request path
ResDat	ARRAY[0..10] OF BYTE	[11(16#0)]	Response data
Dummy	BYTE	16#0	Dummy
RS_instance	RS		
CIPUCMMWrite_instance	CIPUCMMWrite		
CIPUCMMRead_instance	CIPUCMMRead		
CIPUCMMSend_instance	CIPUCMMSend		

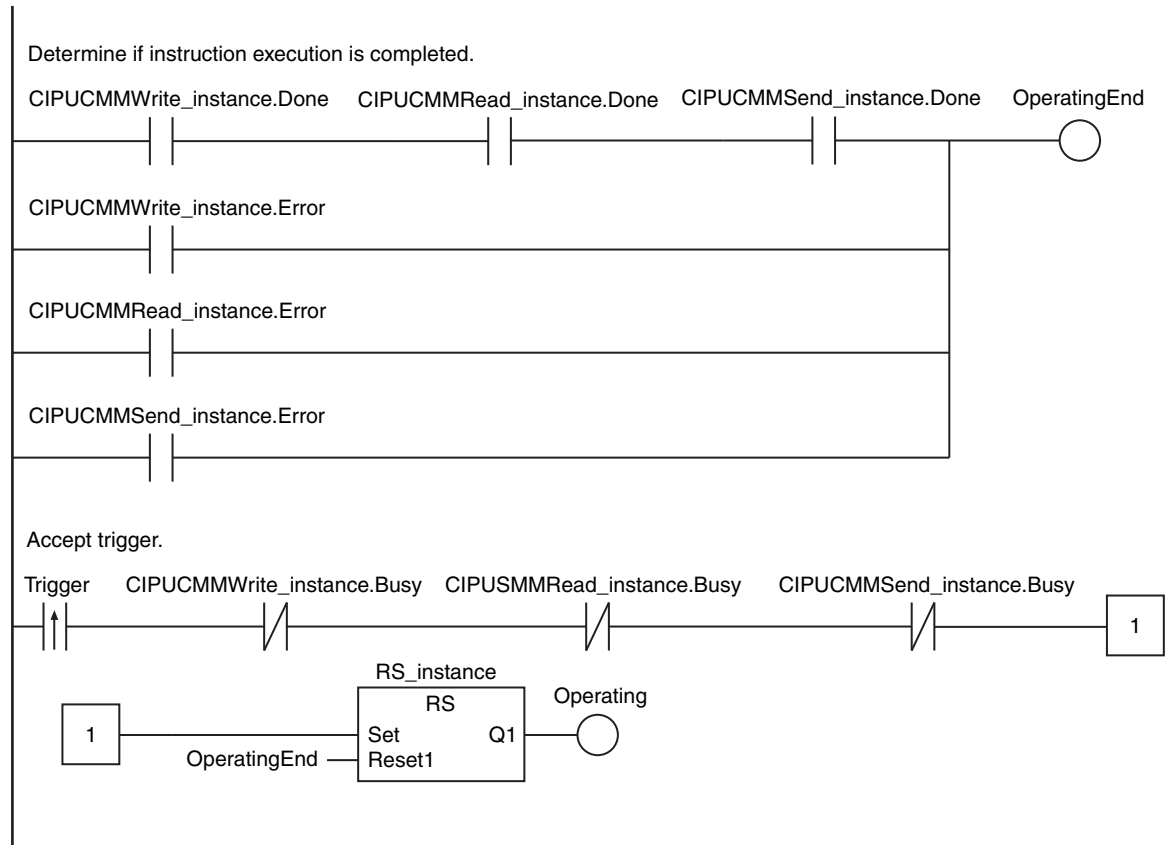

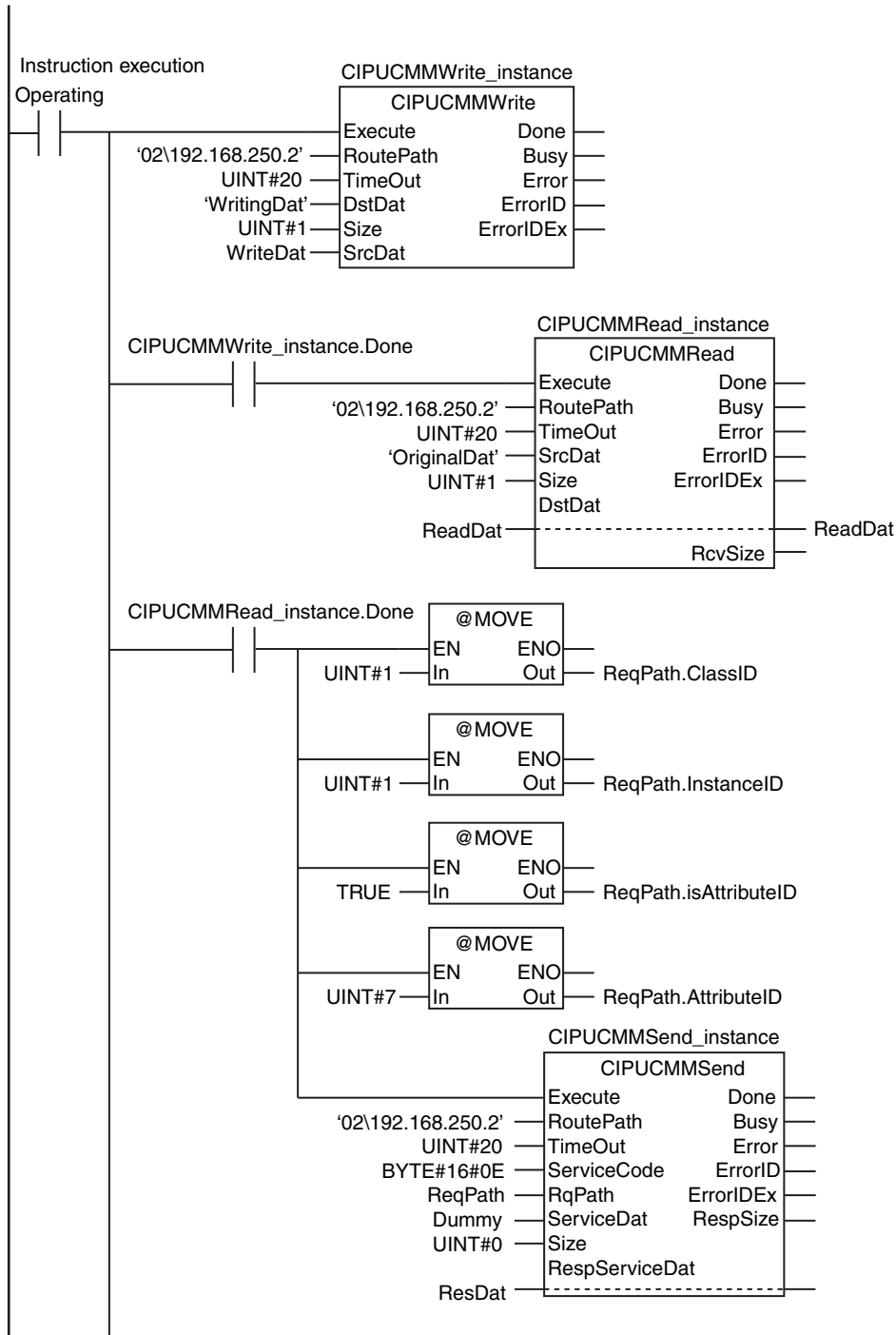

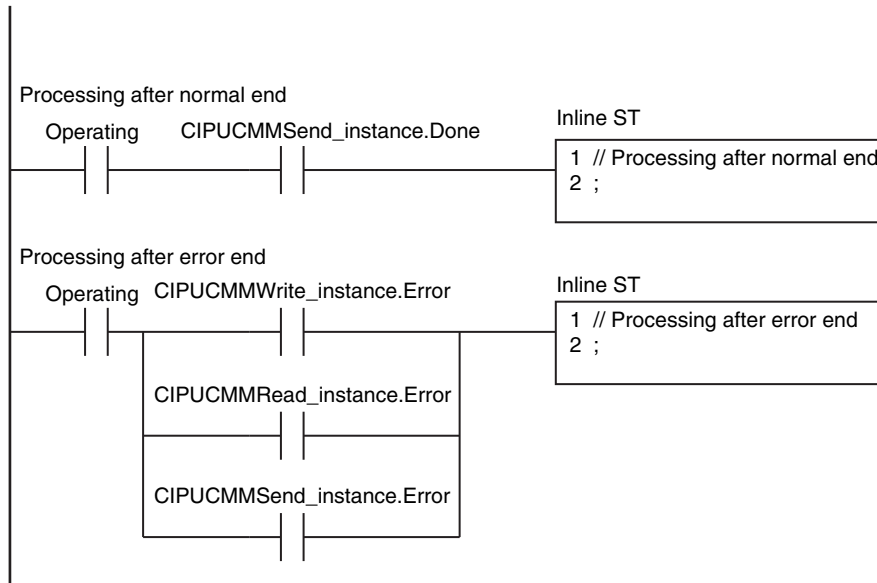

ST

Internal Variables	Variable	Data type	Initial value	Comment
	Trigger	BOOL	FALSE	Execution condition
	DoUCMMTrigger	BOOL	FALSE	Processing
	Stage	INT	0	Stage change
	WriteDat	INT	0	Write data
	ReadDat	INT	0	Read data
	ReqPath	_sREQUEST_PATH	(ClassID:=0, InstanceID:=0, isAttributeID:=FALSE, AttributeID:=0)	Request path
	ResDat	ARRAY[0..10] OF BYTE	[11(16#0)]	Response data
	Dummy	BYTE	16#0	Dummy
	CIPUCMMWrite_instance	CIPUCMMWrite		
	CIPUCMMRead_instance	CIPUCMMRead		
	CIPUCMMSend_instance	CIPUCMMSend		

External Variables	Variable	Constant	Data type	Comment
	_EIP_EtnOnlineSta	✓	BOOL	Online

```
// Start sequence when Trigger changes to TRUE.
IF ( (Trigger=TRUE) AND (DoUCMMTrigger=FALSE) AND (_Eip_EtnOnlineSta=TRUE) ) THEN
  DoUCMMTrigger:=TRUE;
  Stage :=INT#1;
  CIPUCMMWrite_instance(
    Execute :=FALSE, // Initialize instance.
    SrcDat :=WriteDat); // Dummy
  CIPUCMMRead_instance( // Initialize instance.
    Execute :=FALSE, // Dummy
    DstDat :=ReadDat); // Dummy
  CIPUCMMSend_instance(
    Execute :=FALSE, // Initialize instance.
    ServiceDat := Dummy, // Dummy
    RespServiceDat:=ResDat); // Dummy
```

```

END_IF;

IF (DoUCMMTrigger=TRUE) THEN
  CASE Stage OF
    1 :    // Request writing value of variable.
        CIPUCMMWrite_instance(
          Execute    :=TRUE,
          RoutePath :='02\192.168.250.2',    // Route path
          Timeout   :=UINT#20,              // Timeout time
          DstDat    :='WritingDat',         // Destination variable name
          Size      :=UINT#1,               // Number of elements to write
          SrcDat    :=WriteDat);           // Write data

        IF (CIPUCMMWrite_instance.Done=TRUE) THEN
          Stage:=INT#2;    // Normal end
        ELSIF (CIPUCMMWrite_instance.Error=TRUE) THEN
          Stage:=INT#10;  // Error end
          END_IF;

    2 :    // Request reading value of variable.
        CIPUCMMRead_instance(
          Execute    :=TRUE,
          RoutePath :='02\192.168.250.2',    // Route path
          Timeout   :=UINT#20,              // Timeout time
          SrcDat    :='OriginalDat',         // Destination variable name
          Size      :=UINT#1,               // Number of elements to read
          DstDat    :=ReadDat);           // Read data

        IF (CIPUCMMRead_instance.Done=TRUE) THEN
          Stage:=INT#3;    // Normal end
        ELSIF (CIPUCMMRead_instance.Error=TRUE) THEN
          Stage:=INT#40;  // Error end
          END_IF;

    3 :    // Send message
        ReqPath.ClassID    :=UINT#01;
        ReqPath.InstanceID :=UINT#01;
        ReqPath.isAttributeID:=TRUE;
        ReqPath.AttributeID :=UINT#07;
        CIPUCMMSend_instance(
          Execute    :=TRUE,
          RoutePath  :='02\192.168.250.2',    // Route path
          Timeout    :=UINT#20,              // Timeout time
          ServiceCode :=BYTE#16#0E,         // Service code
          RqPath     :=ReqPath,             // Request path
          ServiceDat :=Dummy,               // Service data
          Size       :=UINT#0,              // Number of elements
          RespServiceDat:=ResDat);         // Response data

        IF (CIPUCMMSend_instance.Done=TRUE) THEN
          Stage:=INT#0;    // Normal end
        ELSIF (CIPUCMMSend_instance.Error=TRUE) THEN
          Stage:=INT#30;  // Error end
          END_IF;

    0 :    // Processing after normal end
        DoUCMMTrigger:=FALSE;
        Trigger       :=FALSE;

  ELSE    // Processing after error end
    DoUCMMTrigger:=FALSE;
    Trigger       :=FALSE;
  END_CASE;
END_IF;

```

SktUDPCreate

The SktUDPCreate instruction creates a UDP socket request to open a servo port for the built-in EtherNet/IP.

Instruction	Name	FB/ FUN	Graphic expression	ST expression
SktUDP Create	Create UDP Socket	FB		SktUDPCreate_instance(Execute, SrcUdpPort, Done, Busy, Error, ErrorID, Socket);

Variables

Name	Meaning	I/O	Description	Valid range	Unit	Default
SrcUdpPort	Local UDP port number	Input	Local UDP port number	1 to 65535	---	1
Socket	Socket	Output	Socket	---	---	---

	Boolean	Bit strings					Integers							Real numbers	Times, durations, dates, and text strings					
	BOOL	BYTE	WORD	DWORD	LWORD	USINT	UINT	UDINT	ULINT	SINT	INT	DINT	LINT	REAL	LREAL	TIME	DATE	TOD	DT	STRING
SrcUdpPort							OK													
Socket	Refer to <i>Function</i> for details on the structure <code>_sSOCKET</code> .																			

Function

The SktUDPCreate instruction opens the port specified with the local UDP port number *SrcUdpPort*. To do this, it executes the Socket() and Bind() socket functions. Information on the socket that is opened is stored in *Socket*. The UDP port is open when the instruction is completed normally (i.e., when the value of *Done* changes to TRUE).

The data type of *Socket* is structure `_sSOCKET`. The specifications are as follows:

Name	Meaning	Description	Data type	Valid range	Unit	Default
Socket	Socket	Socket	<code>_sSOCKET</code>	---	---	---
Handle	Handle	Handle for data communications	UDINT	Depends on data type.	---	0
SrcAdr*1	Local address	Local IP address and port number	<code>_sSOCKET_ADDRESS</code>	---	---	---
PortNo	Port number	Port number	UINT	1 to 65535		0
IpAdr*1	IP address	IP address or host name. A DNS or Hosts setting is required to use a host name.	STRING	Depends on data type.	---	„
DstAdr*1	Destination address	Destination IP address and port number	<code>_sSOCKET_ADDRESS</code>	---	---	---
PortNo*1	Port number	Port number	UINT	1 to 65535		0
IpAdr*1	IP address	IP address or host name. A DNS or Hosts setting is required to use a host name.	STRING	Depends on data type.	---	„

*1 A value of 0 or NULL is output for these members.

Related System-defined Variables

Name	Meaning	Data type	Description
<code>_EIP_EtnOnlineSta*1</code>	Online	BOOL	This variable indicates when built-in EtherNet/IP port communications can be used. TRUE: Communications are possible. FALSE: Communications are not possible.
<code>_EIP1_EtnOnlineSta*2</code>			
<code>_EIP2_EtnOnlineSta*3</code>			
<code>_EIPIn1_EtnOnlineSta*4</code>			

*1 Use this variable name for an NJ-series CPU Unit.

*2 Use this variable name for port 1 on an NX-series CPU Unit, or for an NY-series Controller.

*3 Use this variable name for port 2 on an NX-series CPU Unit.

*4 Use this variable name for the internal port on an NY-series Controller.

Additional Information

Refer to the *NJ/NX-series CPU Unit Built-in EtherNet/IP Port User's Manual* (Cat. No. W506) or *NY-series Industrial Panel PC / Industrial Box PC Built-in EtherNet/IP Port User's Manual* (Cat. No. W563) for details on socket services.

Precautions for Correct Use

- Execution of this instruction is continued until processing is completed even if the value of *Execute* changes to FALSE or the execution time exceeds the task period. The value of *Done* changes to TRUE when processing is completed. Use this to confirm normal completion of processing.
- Refer to *Using this Section* on page 2-3 for a timing chart for *Execute*, *Done*, *Busy*, and *Error*.
- This instruction can be used only for the built-in EtherNet/IP on NJ/NX-series CPU Units and NY-series Controllers.
- Use the *SktClose* instruction to close handles that are created with this instruction.
- Handles that are created with this instruction are disabled when you change to PROGRAM mode.

- You can execute a maximum of 32 of the following instructions at the same time: SktUDPCreate, SktUDPRcv, SktUDPSend, SktTCPAccept, SktTCPConnect, SktTCPRcv, SktTCPSend, SktGetTCP-Status, SktClose, SktClearBuf, and SktSetOption.
- An error occurs in the following cases. *Error* will change to TRUE.
 - There is a setting error for the local IP address.
 - The value of *SrcUdpPort* is outside of the valid range.
 - The port that is specified with *SrcUdpPort* is already open or close processing is in progress for it.
 - The port that is specified with *ScrUdpPort* is already in use.

Version Information

- The number of sockets that you can open at the same time depends on the unit version of the CPU Unit as shown in the following table. These limits are the totals for both UDP and TCP sockets.

Unit version of CPU Unit	Number of sockets
1.03 or higher	30 max.
1.02 or lower	16 max.

- For CPU Unit version 1.10 or later, the value of *Socket* does not change even if *Error* changes to TRUE. For version 1.09 or earlier, the value of *Socket* changes to 0.

Sample Programming

In this sample, the UDP socket service is used for data communications between the NJ/NX-series Controller and a remote node.

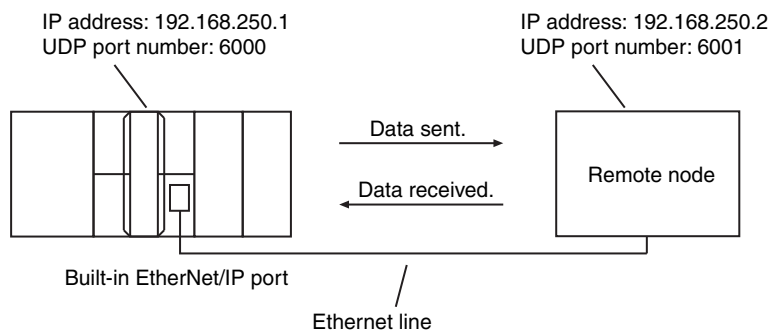

The processing procedure is as follows:

- The SktUDPCreate instruction is used to request creating a UDP socket.
- The SktUDPSend instruction is used to request sending data. The data in *SendSocketDat[]* is sent.
- The SktUDPRcv instruction is used to request receiving data. The received data is stored in *RcvSocketDat[]*.
- The SktClose instruction is used to close the socket.

ST

Internal Variables	Variable	Data type	Initial value	Comment
	Trigger	BOOL	FALSE	Execution condition
	DoSendAndRcv	BOOL	FALSE	Processing
	Stage	INT	0	Stage change
	RcvSocketDat	ARRAY[0..1999] OF BYTE	[2000(16#0)]	Receive data
	WkSocket	_sSOCKET	(Handle:=0, SrcAdr:=(PortNo:=0, IpAdr:="), DstAdr:=(PortNo:=0, IpAdr:="))	Socket
	SendSocketDat	ARRAY[0..1999] OF BYTE	[2000(16#0)]	Send data
	SkUDPCreate_instance	SkUDPCreate		
	SkUDPSend_instance	SkUDPSend		
	SkUDPRcv_instance	SkUDPRcv		
	SkClose_instance	SkClose		

External Variables	Variable	Data type	Constant	Comment
	_EIP_EtnOnlineSta	BOOL	✓	Online

```
// Start sequence when Trigger changes to TRUE.
IF ( (Trigger=TRUE) AND (DoSendAndRcv=FALSE) AND (_Eip_EtnOnlineSta=TRUE) ) THEN
  DoSendAndRcv:=TRUE;
  Stage      :=INT#1;
  SkUDPCreate_instance(Execute:=FALSE);           // Initialize instance.
  SkUDPSend_instance(                               // Initialize instance.
    Execute   :=FALSE,
    SendDat   :=SendSocketDat[0]); // Dummy
  SkUDPRcv_instance(                               // Initialize instance.
    Execute   :=FALSE,
    RcvDat    :=RcvSocketDat[0]); // Dummy
  SkClose_instance(Execute:=FALSE);           // Initialize instance.
END_IF;
```

```
IF (DoSendAndRcv=TRUE) THEN
  CASE Stage OF
  1 : // Request creating socket.
    SkUDPCreate_instance(
      Execute :=TRUE,
      SrcUdpPort:=UINT#6000, // Local UDP port number
      Socket    =>WkSocket); // Socket

    IF (SkUDPCreate_instance.Done=TRUE) THEN
      Stage:=INT#2; // Normal end
    ELSIF (SkUDPCreate_instance.Error=TRUE) THEN
      Stage:=INT#10; // Error end
    END_IF;

  2 : // Request sending data
    WkSocket.DstAdr.PortNo:=UINT#6001;
    WkSocket.DstAdr.IpAdr :='192.168.250.2';
    SkUDPSend_instance(
      Execute:=TRUE,
      Socket :=WkSocket, // Socket
      SendDat:=SendSocketDat[0], // Send data
      Size :=UINT#2000); // Send data size
```



```

        IF (SkUDPSend_instance.Done=TRUE) THEN
            Stage:=INT#3;    // Normal end
        ELSIF (SkUDPSend_instance.Error=TRUE) THEN
            Stage:=INT#20;   // Error end
        END_IF;

3 :    // Request receiving data.
    SkUDPRcv_instance(
        Execute:=TRUE,
        Socket :=WkSocket,           // Socket
        TimeOut:=UINT#0,             // Timeout time
        Size   :=UINT#2000,          // Receive data size
        RcvDat :=RcvSocketDat[0]);  // Receive data

        IF (SkUDPRcv_instance.Done=TRUE) THEN
            Stage:=INT#4;   // Normal end
        ELSIF (SkUDPRcv_instance.Error=TRUE) THEN
            Stage:=INT#30;  // Error end
        END_IF;

4 :    // Request closing.
    SktClose_instance(
        Execute:=TRUE,
        Socket :=WkSocket); // Socket

        IF (SktClose_instance.Done=TRUE) THEN
            Stage:=INT#0;   // Normal end
        ELSIF (SktClose_instance.Error=TRUE) THEN
            Stage:=INT#40;  // Error end
        END_IF;

0 :    // Normal end
    DoSendAndRcv:=FALSE;
    Trigger      :=FALSE;

ELSE   // Interrupted by error.
    DoSendAndRcv:=FALSE;
    Trigger      :=FALSE;
END_CASE;

END_IF;

```

● Programming in the Remote Node

In this example, programming is also required in the remote node. The order of sending and receiving is reversed in comparison with the above procedure.

- 1** The `SktUDPCreate` instruction is used to request creating a UDP socket.
- 2** The `SktUDPRcv` instruction is used to request receiving data. The received data is stored in `RcvSocketDat[]`.
- 3** The `SktUDPSend` instruction is used to request sending data. The data in `SendSocketDat[]` is sent.
- 4** The `SktClose` instruction is used to close the socket.

ST

Internal Variables	Variable	Data type	Initial value	Comment
	Trigger	BOOL	FALSE	Execution condition
	DoSendAndRcv	BOOL	FALSE	Processing
	Stage	INT	0	Stage change
	RcvSocketDat	ARRAY[0..1999] OF BYTE	[2000(16#0)]	Receive data
	WkSocket	_sSOCKET	(Handle:=0, SrcAdr:=(PortNo:=0, IpAdr:="), DstAdr:=(PortNo:=0, IpAdr:="))	Socket
	SendSocketDat	ARRAY[0..1999] OF BYTE	[2000(16#0)]	Send data
	SkUDPCreate_instance	SkUDPCreate		
	SkUDPSend_instance	SkUDPSend		
	SkUDPRcv_instance	SkUDPRcv		
	SkClose_instance	SkClose		

External Variables	Variable	Data type	Constant	Comment
	_EIP_EtnOnlineSta	BOOL	✓	Online

```
// Start sequence when Trigger changes to TRUE.
IF ( (Trigger=TRUE) AND (DoSendAndRcv=FALSE) AND (_Eip_EtnOnlineSta=TRUE) ) THEN
  DoSendAndRcv:=TRUE;
  Stage :=INT#1;
  SkUDPCreate_instance(Execute:=FALSE); // Initialize instance.
  SkUDPSend_instance( // Initialize instance.
    Execute :=FALSE,
    SendDat :=SendSocketDat[0]); // Dummy
  SkUDPRcv_instance( // Initialize instance.
    Execute :=FALSE,
    RcvDat :=RcvSocketDat[0]); // Dummy
  SkClose_instance(Execute:=FALSE); // Initialize instance.
END_IF;
```

```
IF (DoSendAndRcv=TRUE) THEN
  CASE Stage OF
  1 : // Request creating socket.
    SkUDPCreate_instance(
      Execute :=TRUE,
      SrcUdpPort:=UINT#6001, // Local UDP port number
      Socket =>WkSocket); // Socket

    IF (SkUDPCreate_instance.Done=TRUE) THEN
      Stage:=INT#2; // Normal end
    ELSIF (SkUDPCreate_instance.Error=TRUE) THEN
      Stage:=INT#10; // Error end
    END_IF;

  2 : // Request receiving data
    SkUDPRcv_instance(
      Execute:=TRUE,
      Socket :=WkSocket, // Socket
      TimeOut:=UINT#0, // Timeout time
      Size :=UINT#2000, // Receive data size
      RcvDat :=RcvSocketDat[0]); // Receive data
```

```

IF (SkUDPRcv_instance.Done=TRUE) THEN
    Stage:=INT#3; // Normal end
ELSIF (SkUDPRcv_instance.Error=TRUE) THEN
    Stage:=INT#20; // Error end
END_IF;

3 : // Request sending data.
WkSocket.DstAdr.PortNo:=UINT#6000;
WkSocket.DstAdr.IpAdr :='192.168.250.1';
SkUDPSend_instance(
    Execute :=TRUE,
    Socket :=WkSocket, // Socket
    SendDat :=SendSocketDat[0], // Send data
    Size :=UINT#2000); // Send data size

IF (SkUDPSend_instance.Done=TRUE) THEN
    Stage:=INT#4; // Normal end
ELSIF (SkUDPSend_instance.Error=TRUE) THEN
    Stage:=INT#30; // Error end
END_IF;

4 : // Request closing.
SkClose_instance(
    Execute:=TRUE,
    Socket :=WkSocket); // Socket

IF (SkClose_instance.Done=TRUE) THEN
    Stage:=INT#0; // Normal end
ELSIF (SkClose_instance.Error=TRUE) THEN
    Stage:=INT#40; // Error end
END_IF;

0 : // Normal end
DoSendAndRcv:=FALSE;
Trigger :=FALSE;

ELSE // Interrupted by error.
DoSendAndRcv:=FALSE;
Trigger :=FALSE;
END_CASE;

END_IF;

```

SktUDPRcv

The SktUDPRcv instruction reads the data from the receive buffer for a UDP socket for the built-in EtherNet/IP.

Instruction	Name	FB/ FUN	Graphic expression	ST expression
SktUDPRcv	UDP Socket Receive	FB	<pre> graph LR subgraph SktUDPRcv_instance [SktUDPRcv] Execute --- Done Socket --- Busy TimeOut --- Error Size --- ErrorID RcvDat --- RcvSize RcvSize --- SendNodeAdr end </pre>	SktUDPRcv_instance(Execute, Socket, TimeOut, Size, RcvDat, Done, Busy, Error, ErrorID, RcvSize, SendNodeAdr);

Variables

Name	Meaning	I/O	Description	Valid range	Unit	Default
Socket	Socket	Input	Socket	---	---	---
TimeOut	Timeout time		0: No timeouts 1 to 65535: 0.1 to 6553.5s	Depends on data type.	0.1 s	0
Size	Stored size		The number of bytes to read from the receive buffer	0 to 2000	Bytes	1
RcvDat[] (array)	Receive data	In-out	Receive data	Depends on data type.	---	---
RcvSize	Receive data size	Output	The number of bytes actually stored in <i>RcvDat[]</i>	0 to 2000	Bytes	---
SendNodeAdr	Source node address		Source node address	---	---	---

	Boolean	Bit strings					Integers							Real numbers	Times, durations, dates, and text strings					
	BOOL	BYTE	WORD	DWORD	LWORD	USINT	UINT	UDINT	ULINT	SINT	INT	DINT	LINT	REAL	LREAL	TIME	DATE	TOD	DT	STRING
Socket		Refer to <i>Function</i> for details on the structure <code>_sSOCKET</code> .																		
TimeOut							OK													
Size							OK													
RcvDat[] (array)		OK																		
RcvSize							OK													
SendNodeAdr		Refer to <i>Function</i> for details on the structure <code>_sSOCKET_ADDRESS</code> .																		

Function

The SktUDPRcv instruction stores the data in the receive buffer for the socket that is specified with *Socket* in receive data *RcvDat[]*. The number of bytes to store is specified with *Size*. The number of bytes that is actually stored is assigned to *RcvSize*. The node address of the node that sent the data is stored in *SendNodeAdr*.

If there is no data in the receive buffer, the instruction waits for data for the time that is set with timeout time *TimeOut*. Storage of the data to *RcvDat[]* is completed when the instruction is completed normally (i.e., when the value of *Done* changes to TRUE).

The data type of *Socket* is structure `_sSOCKET`. The specifications are as follows:

Name	Meaning	Description	Data type	Valid range	Unit	Default
Socket	Socket	Socket	<code>_sSOCKET</code>	---	---	---
Handle	Handle	Handle for data communications	UDINT	Depends on data type.	---	0
SrcAdr*	Local address	Local IP address and port number	<code>_sSOCKET_ADDRESS</code>	---	---	---
PortNo*	Port number	Port number	UINT	1 to 65535	---	0
IpAdr*	IP address	IP address or host name. A DNS or Hosts setting is required to use a host name.	STRING	Depends on data type.		,
DstAdr*	Destination address	Destination IP address and port number	<code>_sSOCKET_ADDRESS</code>	---	---	---
PortNo*	Port number	Port number	UINT	1 to 65535	---	0
IpAdr*	IP address	IP address or host name. A DNS or Hosts setting is required to use a host name.	STRING	Depends on data type.		,

* These members are not used for this instruction.

The data type of *SendNodeAdr* is structure `_sSOCKET_ADDRESS`. The specifications are as follows:

Name	Meaning	Description	Data type	Valid range	Unit	Default
SendNodeAdr	Source node address	Source node address	<code>_sSOCKET_ADDRESS</code>	---	---	---
PortNo	Port number	UDP port number of the source node	UINT	1 to 65535	---	---
IpAdr	IP address	IP address of the source node	STRING	Depends on data type.	---	---

Related System-defined Variables

Name	Meaning	Data type	Description
<code>_EIP_EtnOnlineSta</code> *1	Online	BOOL	This variable indicates when built-in EtherNet/IP port communications can be used. TRUE: Communications are possible. FALSE: Communications are not possible.
<code>_EIP1_EtnOnlineSta</code> *2			
<code>_EIP2_EtnOnlineSta</code> *3			
<code>_EIPIn1_EtnOnlineSta</code> *4			

*1 Use this variable name for an NJ-series CPU Unit.

*2 Use this variable name for port 1 on an NX-series CPU Unit, or for an NY-series Controller.

*3 Use this variable name for port 2 on an NX-series CPU Unit.

*4 Use this variable name for the internal port on an NY-series Controller.

Additional Information

Refer to the *NJ/NX-series CPU Unit Built-in EtherNet/IP Port User's Manual* (Cat. No. W506) or *NY-series Industrial Panel PC / Industrial Box PC Built-in EtherNet/IP Port User's Manual* (Cat. No. W563) for details on socket services.

Precautions for Correct Use

- Execution of this instruction is continued until processing is completed even if the value of *Execute* changes to FALSE or the execution time exceeds the task period. The value of *Done* changes to TRUE when processing is completed. Use this to confirm normal completion of processing.
- Refer to *Using this Section* on page 2-3 for a timing chart for *Execute*, *Done*, *Busy*, and *Error*.
- This instruction can be used only for the built-in EtherNet/IP on NJ/NX-series CPU Units and NY-series Controllers.
- Up to 2,000 bytes of data can be read from the receive buffer with one instruction.
- If the size of data that was received by the specified socket is smaller than the value of *Size*, then all of the received data is stored in *RecDat[]*. Then size of data that was stored is stored in *RcvSize*.
- If the size of data that was received by the specified socket is larger than the value of *Size*, then the size of received data specified by *Size* is stored in *RecDat[]*.
- The receive data is not read if the value of *Size* is 0.
- If the *SktClose* instruction closes the connection when there is no data in the receive buffer, a normal end occurs without waiting to receive data even if a timeout has not occurred. The value of *RcvSize* is 0 in that case.
- You can execute a maximum of 32 of the following instructions at the same time: *SktUDPCreate*, *SktUDPRcv*, *SktUDPSend*, *SktTCPAccept*, *SktTCPConnect*, *SktTCPRcv*, *SktTCPSend*, *SktGetTCP-Status*, *SktClose*, *SktClearBuf*, and *SktSetOption*.
- An error occurs in the following cases. *Error* will change to TRUE.
 - There is a setting error for the local IP address.
 - Data reception is in progress for the socket specified with *Socket*.
 - The socket specified with *Socket* is not open.
 - The handle specified by *Socket.Handle* does not exist.

Sample Programming

Refer to the sample programming that is provided for the *SktUDPCreate* instruction (page 2-1073).

SktUDPSend

The SktUDPSend instruction sends data from a UDP port for the built-in EtherNet/IP.

Instruction	Name	FB/ FUN	Graphic expression	ST expression
SktUDPSend	UDP Socket Send	FB		SktUDPSend_instance(Execute, Socket, SendDat, Size, Done, Busy, Error, ErrorID);

Variables

Name	Meaning	I/O	Description	Valid range	Unit	Default
Socket	Socket	Input	Socket	---	---	---
SendDat[] (array)	Send data		Send data	Depends on data type.		
Size	Send data size		Send data size	0 to 2000	Bytes	1

	Boolean	Bit strings				Integers							Real numbers	Times, durations, dates, and text strings							
	BOOL	BYTE	WORD	DWORD	LWORD	USINT	UINT	UDINT	ULINT	SINT	INT	DINT	LINT	REAL	LREAL	TIME	DATE	TOD	DT	STRING	
Socket																					
SendDat[] (array)		OK																			
Size							OK														

Function

The SktUDPSend instruction sends send data *SendDat[]* from the socket that is specified with *Socket*. The number of bytes to send is specified with *Size*. The remote node is specified with *Socket.DstAdr*. Transmission of *SendDat[]* to the send buffer is completed when the instruction is completed normally (i.e., when the value of *Done* changes to TRUE).

The data type of *Socket* is structure `_sSOCKET`. The specifications are as follows:

Name	Meaning	Description	Data type	Valid range	Unit	Default
Socket	Socket	Socket	<code>_sSOCKET</code>	---	---	---
Handle	Handle	Handle for data communications	UDINT	Depends on data type.	---	0
SrcAdr*	Local address	Local IP address and port number	<code>_sSOCKET_ADDRESS</code>	---	---	---
PortNo*	Port number	Port number	UINT	1 to 65535		0
IpAdr*	IP address	IP address or host name. A DNS or Hosts setting is required to use a host name.	STRING	Depends on data type.	---	,"
DstAdr	Destination address	Destination IP address and port number	<code>_sSOCKET_ADDRESS</code>	---	---	---
PortNo	Port number	Port number	UINT	1 to 65535		0
IpAdr	IP address	IP address or host name. A DNS or Hosts setting is required to use a host name.	STRING	Depends on data type.	---	,"

* These members are not used for this instruction.

Related System-defined Variables

Name	Meaning	Data type	Description
<code>_EIP_EtnOnlineSta</code> *1	Online	BOOL	This variable indicates when built-in EtherNet/IP port communications can be used. TRUE: Communications are possible. FALSE: Communications are not possible.
<code>_EIP1_EtnOnlineSta</code> *2			
<code>_EIP2_EtnOnlineSta</code> *3			
<code>_EIPIn1_EtnOnlineSta</code> *4			

*1 Use this variable name for an NJ-series CPU Unit.

*2 Use this variable name for port 1 on an NX-series CPU Unit, or for an NY-series Controller.

*3 Use this variable name for port 2 on an NX-series CPU Unit.

*4 Use this variable name for the internal port on an NY-series Controller.

Additional Information

Refer to the *NJ/NX-series CPU Unit Built-in EtherNet/IP Port User's Manual* (Cat. No. W506) or *NY-series Industrial Panel PC / Industrial Box PC Built-in EtherNet/IP Port User's Manual* (Cat. No. W563) for details on socket services.

Precautions for Correct Use

- Execution of this instruction is continued until processing is completed even if the value of *Execute* changes to FALSE or the execution time exceeds the task period. The value of *Done* changes to TRUE when processing is completed. Use this to confirm normal completion of processing.
- Refer to *Using this Section* on page 2-3 for a timing chart for *Execute*, *Done*, *Busy*, and *Error*.
- This instruction can be used only for the built-in EtherNet/IP on NJ/NX-series CPU Units and NY-series Controllers.
- Up to 2,000 bytes of data can be sent with one instruction. A maximum of 2,000 bytes is sent even if the *SendDat[]* array is larger than 2,000 bytes. Only 1,472 bytes can be sent if the broadcast address is specified.
- If the value of *Size* is 0, then 0 bytes of send data is transmitted on the line.

- You can execute a maximum of 32 of the following instructions at the same time: SktUDPCreate, SktUDPRcv, SktUDPSend, SktTCPAccept, SktTCPConnect, SktTCPRcv, SktTCPStatus, SktClose, SktClearBuf, and SktSetOption.
- An error occurs in the following cases. *Error* will change to TRUE.
 - There is a setting error for the local IP address.
 - The value of a member of *Socket* is outside of the valid range.
 - Data transmission is in progress for the socket specified with *Socket*.
 - The socket specified with *Socket* is not open.
 - The remote node for *Socket* was specified with a domain name and address resolution failed.
 - The handle specified by *Socket.Handle* does not exist.
 - The value of *Size* exceeds the number of elements in *SendDat[]*.

Sample Programming

Refer to the sample programming that is provided for the SktUDPCreate instruction (page 2-1073).

SkTcPAccept

The SkTcPAccept instruction requests accepting a TCP socket for the built-in EtherNet/IP.

Instruction	Name	FB/ FUN	Graphic expression	ST expression
SkTcPAccept	Accept TCP Socket	FB		SkTcPAccept_instance(Execute, SrcTcpPort, TimeOut, Done, Busy, Error, ErrorID, Socket);

Variables

Name	Meaning	I/O	Description	Valid range	Unit	Default
SrcTcpPort	Local TCP port number	Input	Local TCP port number	1 to 65535	---	1
TimeOut	Timeout time		0: No timeouts 1 to 65535: 0.1 to 6553.5s	Depends on data type.	0.1 s	0
Socket	Socket	Output	Socket	---	---	---

	Boolean	Bit strings				Integers							Real numbers	Times, durations, dates, and text strings						
	BOOL	BYTE	WORD	DWORD	LWORD	USINT	UINT	UDINT	ULINT	SINT	INT	DINT	LINT	REAL	LREAL	TIME	DATE	TOD	DT	STRING
SrcTcpPort							OK													
TimeOut							OK													
Socket	Refer to <i>Function</i> for details on the structure <code>_sSOCKET</code> .																			

Function

The SkTcPAccept instruction requests accepting the port specified with the local TCP port number *SrcTcpPort*. To do this, it executes the `Socket()`, `Bind()`, `Listen()`, and `Accept()` socket functions. The instruction waits for the time set with timeout time *TimeOut* for a connection to be established with the remote node. The connection is established when the instruction is completed normally (i.e., when the value of *Done* changes to TRUE).

The data type of *Socket* is structure `_sSOCKET`. The specifications are as follows:

Name	Meaning	Description	Data type	Valid range	Unit	Default
Socket	Socket	Socket	<code>_sSOCKET</code>	---	---	---
Handle	Handle	Handle for data communications	UDINT	Depends on data type.	---	0
SrcAdr	Local address	Local IP address and port number	<code>_sSOCKET_ADDRESS</code>	---	---	---
PortNo	Port number	Port number	UINT	1 to 65535		0
IpAdr*1	IP address	IP address or host name. A DNS or Hosts setting is required to use a host name.	STRING	Depends on data type.	---	“
DstAdr	Destination address	Destination IP address and port number	<code>_sSOCKET_ADDRESS</code>	---	---	---
PortNo	Port number	Port number	UINT	1 to 65535		0
IpAdr	IP address	IP address or host name. A DNS or Hosts setting is required to use a host name.	STRING	Depends on data type.	---	“

*1 NULL is output for this member.

Related System-defined Variables

Name	Meaning	Data type	Description
<code>_EIP_EtnOnlineSta*1</code>	Online	BOOL	This variable indicates when built-in EtherNet/IP port communications can be used. TRUE: Communications are possible. FALSE: Communications are not possible.
<code>_EIP1_EtnOnlineSta*2</code>			
<code>_EIP2_EtnOnlineSta*3</code>			
<code>_EIPIn1_EtnOnlineSta*4</code>			

*1 Use this variable name for an NJ-series CPU Unit.

*2 Use this variable name for port 1 on an NX-series CPU Unit, or for an NY-series Controller.

*3 Use this variable name for port 2 on an NX-series CPU Unit.

*4 Use this variable name for the internal port on an NY-series Controller.

Additional Information

- Refer to the *NJ/NX-series CPU Unit Built-in EtherNet/IP Port User's Manual* (Cat. No. W506) or *NY-series Industrial Panel PC / Industrial Box PC Built-in EtherNet/IP Port User's Manual* (Cat. No. W563) for details on socket services.
- You can execute this instruction more than once to open connections to more than one client with one local port number. A different socket is returned for each connection.

Precautions for Correct Use

- Execution of this instruction is continued until processing is completed even if the value of *Execute* changes to FALSE or the execution time exceeds the task period. The value of *Done* changes to TRUE when processing is completed. Use this to confirm normal completion of processing.
- Refer to *Using this Section* on page 2-3 for a timing chart for *Execute*, *Done*, *Busy*, and *Error*.
- This instruction can be used only for the built-in EtherNet/IP on NJ/NX-series CPU Units and NY-series Controllers.
- Use the *SktClose* instruction to close handles that are created with this instruction.
- Handles that are created with this instruction are disabled when you change to PROGRAM mode.
- You can execute a maximum of 32 of the following instructions at the same time: *SktUDPCreate*, *SktUDPRcv*, *SktUDPSend*, *SktTCPAccept*, *SktTCPConnect*, *SktTCPRcv*, *SktTCPSend*, *SktGetTCPStatus*, *SktClose*, *SktClearBuf*, and *SktSetOption*.
- An error occurs in the following cases. *Error* will change to TRUE.
 - There is a setting error for the local IP address.
 - The value of *SrcTcpPort* is outside of the valid range.
 - Open processing is in progress for the socket specified with *SrcTcpPort*.
 - Close processing is in progress for the socket specified with *SrcTcpPort*.
 - A connection is not opened within the time that is specified with *TimeOut*.



Version Information

- The number of sockets that you can open at the same time depends on the unit version of the CPU Unit as shown in the following table. These limits are the totals for both UDP and TCP sockets.

Unit version of CPU Unit	Number of sockets
1.03 or higher	30 max.
1.02 or lower	16 max.

- For CPU Unit version 1.10 or later, the value of *Socket* does not change even if *Error* changes to TRUE. For version 1.09 or earlier, the value of *Socket* changes to 0.

Sample Programming

Refer to the sample programming that is provided for the *SktTCPConnect* instruction (page 2-1090).

SkdTCPConnect

The SkdTCPConnect instruction connects to a remote TCP port from the built-in EtherNet/IP.

Instruction	Name	FB/ FUN	Graphic expression	ST expression
SkdTCP Connect	Connect TCP Socket	FB		SkdTCPConnect_instance(Execute, SrcTcpPort, DstAdr, DstTcpPort, Done, Busy, Error, ErrorID, Socket);

Variables

Name	Meaning	I/O	Description	Valid range	Unit	Default
SrcTcpPort	Local TCP port number	Input	Local TCP port number. If 0 is specified, an available TCP port that is 1024 or higher is automatically assigned. Well-known port numbers are not assigned.	Depends on data type.	---	0
DstAdr	Destination address		Destination IP address or host name	200 bytes max.		---
DstTcpPort	Destination TCP port number		Destination TCP port number	1 to 65,535		1
Socket	Socket	Output	Socket	---	---	---

	Boolean	Bit strings					Integers							Real numbers		Times, durations, dates, and text strings				
	BOOL	BYTE	WORD	DWORD	LWORD	USINT	UINT	UDINT	ULINT	SINT	INT	DINT	LINT	REAL	LREAL	TIME	DATE	TOD	DT	STRING
SrcTcpPort							OK													
DstAdr																				OK
DstTcpPort							OK													
Socket	Refer to <i>Function</i> for details on the structure <code>_sSOCKET</code> .																			

Function

The SktTCPConnect instruction requests a connection between local TCP port number *SrcTcpPort* and destination TCP port number *DstTcpPort* at destination address *DstAdr*. To do this, it executes the Connect() socket function. The connection is established when the instruction is completed normally (i.e., when the value of *Done* changes to TRUE).

The data type of *Socket* is structure `_sSOCKET`. The specifications are as follows:

Name	Meaning	Description	Data type	Valid range	Unit	Default
Socket	Socket	Socket	<code>_sSOCKET</code>	---	---	---
Handle	Handle	Handle for data communications	UDINT	Depends on data type.	---	0
SrcAdr	Local address	Local IP address and port number	<code>_sSOCKET_ADDRESS</code>	---	---	---
PortNo	Port number	Port number	UINT	1 to 65535		0
IpAdr*1	IP address	IP address or host name. A DNS or Hosts setting is required to use a host name.	STRING	Depends on data type.	---	"
DstAdr	Destination address	Destination IP address and port number	<code>_sSOCKET_ADDRESS</code>	---	---	---
PortNo	Port number	Port number	UINT	1 to 65535		0
IpAdr	IP address	IP address or host name. A DNS or Hosts setting is required to use a host name.	STRING	Depends on data type.	---	"

*1 NULL is output for this member.

Related System-defined Variables

Name	Meaning	Data type	Description
<code>_EIP_EtnOnlineSta</code> *1	Online	BOOL	This variable indicates when built-in EtherNet/IP port communications can be used. TRUE: Communications are possible. FALSE: Communications are not possible.
<code>_EIP1_EtnOnlineSta</code> *2			
<code>_EIP2_EtnOnlineSta</code> *3			
<code>_EIPIn1_EtnOnlineSta</code> *4			

*1 Use this variable name for an NJ-series CPU Unit.

*2 Use this variable name for port 1 on an NX-series CPU Unit, or for an NY-series Controller.

*3 Use this variable name for port 2 on an NX-series CPU Unit.

*4 Use this variable name for the internal port on an NY-series Controller.

Additional Information

Refer to the *NJ/NX-series CPU Unit Built-in EtherNet/IP Port User's Manual* (Cat. No. W506) or *NY-series Industrial Panel PC / Industrial Box PC Built-in EtherNet/IP Port User's Manual* (Cat. No. W563) for details on socket services.

Precautions for Correct Use

- Execution of this instruction is continued until processing is completed even if the value of *Execute* changes to FALSE or the execution time exceeds the task period. The value of *Done* changes to TRUE when processing is completed. Use this to confirm normal completion of processing.
- Refer to *Using this Section* on page 2-3 for a timing chart for *Execute*, *Done*, *Busy*, and *Error*.
- This instruction can be used only for the built-in EtherNet/IP on NJ/NX-series CPU Units and NY-series Controllers.
- Use the *SktClose* instruction to close handles that are created with this instruction.
- Handles that are created with this instruction are disabled when you change to PROGRAM mode.
- You can execute a maximum of 32 of the following instructions at the same time: *SktUDPCreate*, *SktUDPRcv*, *SktUDPSend*, *SktTCPAccept*, *SktTCPConnect*, *SktTCPRcv*, *SktTCPSend*, *SktGetTCP-Status*, *SktClose*, *SktClearBuf*, and *SktSetOption*.
- An error occurs in the following cases. *Error* will change to TRUE.
 - There is a setting error for the local IP address.
 - The value of *DstAdr* is outside of the valid range.
 - The value of *DstTcpPort* is outside of the valid range.
 - The TCP port that is specified with *SrcTcpPort* is already open.
 - The remote node that is specified with *DstAdr* does not exist.
 - The remote node that is specified with *DstAdr* and *DstTcpPort* is not waiting for a connection.
 - Address resolution failed for the host name that is specified with *DstAdr*.
 - A connection is already open for the same client (IP address and TCP port).



Version Information

- The number of sockets that you can open at the same time depends on the unit version of the CPU Unit as shown in the following table. These limits are the totals for both UDP and TCP sockets.

Unit version of CPU Unit	Number of sockets
1.03 or higher	30 max.
1.02 or lower	16 max.

- For CPU Unit version 1.10 or later, the value of *Socket* does not change even if *Error* changes to TRUE. For version 1.09 or earlier, the value of *Socket* changes to 0.

Sample Programming

In this sample, the TCP socket service is used for data communications between the NJ/NX-series Controller and a remote node.

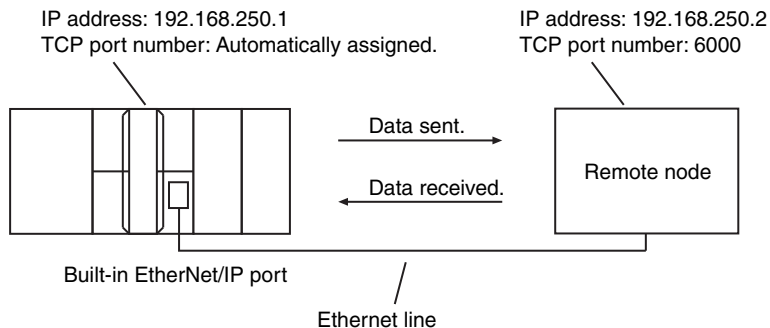

The processing procedure is as follows:

- 1** The SktTCPConnect instruction is used to request connecting to the TCP port on the remote node.
- 2** The SktClearBuf instruction is used to clear the receive buffer for a TCP socket.
- 3** The SktGetTCPStatus instruction is used to read the status of a TCP socket.
- 4** The SktTCPSend instruction is used to request sending data. The data in *SendSocketDat[]* is sent.
- 5** The SktTCPRcv instruction is used to request receiving data. The received data is stored in *RcvSocketDat[]*.
- 6** The SktClose instruction is used to close the socket.

ST

Internal Variables	Variable	Data type	Initial value	Comment
	Trigger	BOOL	FALSE	Execution condition
	DoTCP	BOOL	FALSE	Processing
	Stage	INT	0	Stage change
	RcvSocketDat	ARRAY[0..1999] OF BYTE	[2000(16#0)]	Receive data
	WkSocket	_sSOCKET	(Handle:=0, SrcAdr:=(PortNo:=0, IpAdr:="), DstAdr:=(PortNo:=0, IpAdr:="))	Socket
	SendSocketDat	ARRAY[0..1999] OF BYTE	[2000(16#0)]	Send data
	SkdTCPConnect_instance	SkdTCPConnect		
	SkdClearBuf_instance	SkdClearBuf		
	SkdGetTCPStatus_instance	SkdGetTCPStatus		
	SkdTCPSEND_instance	SkdTCPSEND		
	SkdTCPRcv_instance	SkdTCPRcv		
	SkdClose_instance	SkdClose		

External Variables	Variable	Data type	Constant	Comment
	_EIP_EtnOnlineSta	BOOL	✓	Online

```
// Start sequence when Trigger changes to TRUE.
IF ( (Trigger=TRUE) AND (DoTCP=FALSE) AND (_Eip_EtnOnlineSta=TRUE) ) THEN
  DoTCP :=TRUE;
  Stage :=INT#1;
  SkdTCPConnect_instance(Execute:=FALSE); // Initialize instance.
  SkdClearBuf_instance(Execute:=FALSE); // Initialize instance.
  SkdGetTCPStatus_instance(Execute:=FALSE); // Initialize instance.
  SkdTCPSEND_instance(
    Execute:=FALSE,
    SendDat:=SendSocketDat[0]; // Dummy
  SkdTCPRcv_instance(
    Execute:=FALSE,
    RcvDat :=RcvSocketDat[0]; // Dummy
  SkdClose_instance(Execute:=FALSE); // Initialize instance.
END_IF;

IF (DoTCP=TRUE) THEN
  CASE Stage OF
  1 : // Request a connection.
    SkdTCPConnect_instance(
      Execute :=TRUE,
      SrcTcpPort:=UINT#0, // Local TCP port number: Automatically assigned.
      DstAdr :='192.168.250.2', // Remote IP address
      DstTcpPort:=UINT#6000, // Destination TCP port number
      Socket =>WkSocket); // Socket

    IF (SkdTCPConnect_instance.Done=TRUE) THEN
      Stage:=INT#2; // Normal end
    ELSIF (SkdTCPConnect_instance.Error=TRUE) THEN
      Stage:=INT#10; // Error end
    END_IF;
  END_IF;

```

```

2 : // Clear receive buffer.
    SktClearBuf_instance(
        Execute:=TRUE,
        Socket :=WkSocket); // Socket

    IF (SktClearBuf_instance.Done=TRUE) THEN
        Stage:=INT#3; // Normal end
    ELSIF (SktClearBuf_instance.Error=TRUE) THEN
        Stage:=INT#20; // Error end
    END_IF;

3 : // Request reading status.
    SktGetTCPStatus_instance(
        Execute:=TRUE,
        Socket :=WkSocket); // Socket

    IF (SktGetTCPStatus_instance.Done=TRUE) THEN
        Stage:=INT#4; // Normal end
    ELSIF (SktGetTCPStatus_instance.Error=TRUE) THEN
        Stage:=INT#30; // Error end
    END_IF;

4 : // Request sending data
    SktTCPSEND_instance(
        Execute:=TRUE,
        Socket :=WkSocket, // Socket
        SendDat:=SendSocketDat[0], // Send data
        Size :=UINT#2000); // Send data size

    IF (SktTCPSEND_instance.Done=TRUE) THEN
        Stage:=INT#5; // Normal end
    ELSIF (SktTCPSEND_instance.Error=TRUE) THEN
        Stage:=INT#40; // Error end
    END_IF;

5 : // Request receiving data
    SktTCPRCV_instance(
        Execute:=TRUE,
        Socket :=WkSocket, // Socket
        TimeOut:=UINT#0, // Timeout time
        Size :=UINT#2000, // Receive data size
        RcvDat :=RcvSocketDat[0]); // Receive data

    IF (SktTCPRCV_instance.Done=TRUE) THEN
        Stage:=INT#6; // Normal end
    ELSIF (SktTCPRCV_instance.Error=TRUE) THEN
        Stage:=INT#50; // Error end
    END_IF;

6 : // Request closing.
    SktClose_instance(
        Execute:=TRUE,
        Socket :=WkSocket); // Socket

    IF (SktClose_instance.Done=TRUE) THEN
        Stage:=INT#0; // Normal end
    ELSIF (SktClose_instance.Error=TRUE) THEN
        Stage:=INT#40; // Error end
    END_IF;

0 : // Normal end
    DoTCP :=FALSE;
    Trigger :=FALSE;

```

```
ELSE // Interrupted by error.  
    DoTCP :=FALSE;  
    Trigger :=FALSE;  
END_CASE;  
  
END_IF;
```

● Programming in the Remote Node

In this example, programming is also required in the remote node. The order of sending and receiving is reversed in comparison with the above procedure.

- 1** The SktTCPAccept instruction is used to request accepting a TCP socket.
- 2** The SktTCPRcv instruction is used to request receiving data. The received data is stored in *RcvSocketDat[]*.
- 3** The SktTCPSend instruction is used to request sending data. The data in *SendSocketDat[]* is sent.
- 4** The SktClose instruction is used to close the socket.

ST

Internal Variables	Variable	Data type	Initial value	Comment
	Trigger	BOOL	FALSE	Execution condition
	DoTCP	BOOL	FALSE	Processing
	Stage	INT	0	Stage change
	RcvSocketDat	ARRAY[0..1999] OF BYTE	[2000(16#0)]	Receive data
	WkSocket	_sSOCKET	(Handle:=0, SrcAdr:=(PortNo:=0, IpAdr:="), DstAdr:=(PortNo:=0, IpAdr:="))	Socket
	SendSocketDat	ARRAY[0..1999] OF BYTE	[2000(16#0)]	Send data
	SkTcPAccept_instance	SkTcPAccept		
	SkTcPSEND_instance	SkTcPSEND		
	SkTcPRcv_instance	SkTcPRcv		
	SkTcClose_instance	SkTcClose		

External Variables	Variable	Data type	Constant	Comment
	_EIP_EtnOnlineSta	BOOL	✓	Online

```
// Start sequence when Trigger changes to TRUE.
IF ( Trigger=TRUE) AND (DoTCP=FALSE) AND ( _Eip_EtnOnlineSta=TRUE) ) THEN
  DoTCP:=TRUE;
  Stage:=INT#1;
  SkTcPAccept_instance(Execute:=FALSE); // Initialize instance.
  SkTcPSEND_instance( // Initialize instance.
    Execute :=FALSE,
    SendDat :=SendSocketDat [0]); // Dummy
  SkTcPRcv_instance( // Initialize instance.
    Execute :=FALSE,
    RcvDat :=RcvSocketDat [0]); // Dummy
  SkTcClose_instance(Execute:=FALSE); // Initialize instance.
END_IF;
```

```
IF (DoTCP=TRUE) THEN
  CASE Stage OF
  1 : // Request accepting a socket connection.
    SkTcPAccept_instance(
      Execute :=TRUE,
      SrcTcpPort:=UINT#6000, // Local TCP port number
      TimeOut :=UINT#0, // Timeout time
      Socket =>WkSocket); // Socket

    IF (SkTcPAccept_instance.Done=TRUE) THEN
      Stage:=INT#2; // Normal end
    ELSIF (SkTcPAccept_instance.Error=TRUE) THEN
      Stage:=INT#10; // Error end
    END_IF;

  2 : // Request receiving data
    SkTcPRcv_instance(
      Execute:=TRUE,
      Socket :=WkSocket, // Socket
      TimeOut:=UINT#0, // Timeout time
      Size :=UINT#2000, // Receive data size
      RcvDat :=RcvSocketDat [0]); // Receive data
```

```

IF (SkdTCPRcv_instance.Done=TRUE) THEN
    Stage:=INT#3;    // Normal end
ELSIF (SkdTCPRcv_instance.Error=TRUE) THEN
    Stage:=INT#20;   // Error end
END_IF;

3 :    // Request sending data.
SendSocketDat:=RcvSocketDat;
SkdTCPSend_instance(
    Execute:=TRUE,
    Socket :=WkSocket,           // Socket
    SendDat:=SendSocketDat[0], // Send data
    Size   :=UINT#2000);        // Send data size

IF (SkdTCPSend_instance.Done=TRUE) THEN
    Stage:=INT#4;   // Normal end
ELSIF (SkdTCPSend_instance.Error=TRUE) THEN
    Stage:=INT#30; // Error end
END_IF;

4 :    // Request closing.
SkdClose_instance(
    Execute:=TRUE,
    Socket :=WkSocket); // Socket

IF (SkdClose_instance.Done=TRUE) THEN
    Stage:=INT#0;   // Normal end
ELSIF (SkdClose_instance.Error=TRUE) THEN
    Stage:=INT#40; // Error end
END_IF;

0 :    // Normal end
DoTCP :=FALSE;
Trigger:=FALSE;

ELSE // Interrupted by error.
    DoTCP :=FALSE;
    Trigger:=FALSE;
END_CASE;

END_IF;

```

SkTTCPRcv

The SkTTCPRcv instruction reads the data from the receive buffer for a TCP socket for the built-in EtherNet/IP.

Instruction	Name	FB/ FUN	Graphic expression	ST expression
SkTTCPRcv	TCP Socket Receive	FB	<pre> SkTTCPRcv_instance SkTTCPRcv Execute --- Done Socket --- Busy TimeOut --- Error Size --- ErrorID RcvDat --- RcvSize --- </pre>	SkTTCPRcv_instance(Execute, Socket, TimeOut, Size, RcvDat, Done, Busy, Error, ErrorID, RcvSize);

Variables

Name	Meaning	I/O	Description	Valid range	Unit	Default
Socket	Socket	Input	Socket	---	---	---
TimeOut	Timeout time		0: No timeouts 1 to 65535: 0.1 to 6553.5s	Depends on data type.	0.1 s	0
Size	Stored size		The number of bytes to read from the receive buffer	0 to 2000	Bytes	1
RcvDat[] (array)	Receive data	In-out	Receive data	Depends on data type.	---	---
RcvSize	Receive data size	Output	The number of bytes actually stored in <i>RcvDat[]</i>	1 to 2000	Bytes	---

	Boolean	Bit strings				Integers							Real numbers		Times, durations, dates, and text strings						
	BOOL	BYTE	WORD	DWORD	LWORD	USINT	UINT	UDINT	ULINT	SINT	INT	DINT	LINT	REAL	LREAL	TIME	DATE	TOD	DT	STRING	
Socket																					
TimeOut							OK														
Size							OK														
RcvDat[] (array)		OK																			
RcvSize							OK														

Function

The SktTCPRcv instruction stores the data in the receive buffer for the socket that is specified with *Socket* in receive data *RcvDat[]*. The number of bytes to store is specified with *Size*. The number of bytes that is actually stored is assigned to *RcvSize*. If there is no data in the receive buffer, the instruction waits for data for the time that is set with timeout time *TimeOut*. Storage of the data to *RcvDat[]* is completed when the instruction is completed normally (i.e., when the value of *Done* changes to TRUE).

The data type of *Socket* is structure `_sSOCKET`. The specifications are as follows:

Name	Meaning	Description	Data type	Valid range	Unit	Default
Socket	Socket	Socket	<code>_sSOCKET</code>	---	---	---
Handle	Handle	Handle for data communications	UDINT	Depends on data type.	---	0
SrcAdr*	Local address	Local IP address and port number	<code>_sSOCKET_ADDRESS</code>	---	---	---
PortNo*	Port number	Port number	UINT	1 to 65535		0
IpAdr*	IP address	IP address or host name. A DNS or Hosts setting is required to use a host name.	STRING	Depends on data type.	---	''
DstAdr*	Destination address	Destination IP address and port number	<code>_sSOCKET_ADDRESS</code>	---	---	---
PortNo*	Port number	Port number	UINT	1 to 65535		0
IpAdr*	IP address	IP address or host name. A DNS or Hosts setting is required to use a host name.	STRING	Depends on data type.	---	''

* These members are not used for this instruction.

Related System-defined Variables

Name	Meaning	Data type	Description
<code>_EIP_EtnOnlineSta</code> *1	Online	BOOL	This variable indicates when built-in EtherNet/IP port communications can be used. TRUE: Communications are possible. FALSE: Communications are not possible.
<code>_EIP1_EtnOnlineSta</code> *2			
<code>_EIP2_EtnOnlineSta</code> *3			
<code>_EIPIn1_EtnOnlineSta</code> *4			

*1 Use this variable name for an NJ-series CPU Unit.

*2 Use this variable name for port 1 on an NX-series CPU Unit, or for an NY-series Controller.

*3 Use this variable name for port 2 on an NX-series CPU Unit.

*4 Use this variable name for the internal port on an NY-series Controller.

Additional Information

Refer to the *NJ/NX-series CPU Unit Built-in EtherNet/IP Port User's Manual* (Cat. No. W506) or *NY-series Industrial Panel PC / Industrial Box PC Built-in EtherNet/IP Port User's Manual* (Cat. No. W563) for details on socket services.

Precautions for Correct Use

- Execution of this instruction is continued until processing is completed even if the value of *Execute* changes to FALSE or the execution time exceeds the task period. The value of *Done* changes to TRUE when processing is completed. Use this to confirm normal completion of processing.
- Refer to *Using this Section* on page 2-3 for a timing chart for *Execute*, *Done*, *Busy*, and *Error*.
- This instruction can be used only for the built-in EtherNet/IP on NJ/NX-series CPU Units and NY-series Controllers.
- Up to 2,000 bytes of data can be read with one instruction. A maximum of 2,000 bytes is read even if the *RcvDat[]* array is larger than 2,000 bytes.
- If the size of data that was received by the specified socket is smaller than the value of *Size*, then all of the received data is stored in *RecDat[]*. Then size of data that was stored is stored in *RcvSize*.
- If the size of data that was received by the specified socket is larger than the value of *Size*, then the size of received data specified by *Size* is stored in *RecDat[]*.
- The receive data is not read if the value of *Size* is 0.
- If the *SktClose* instruction closes the connection when there is no data in the receive buffer, an error end occurs even if a timeout has not occurred.
- You can execute a maximum of 32 of the following instructions at the same time: *SktUDPCreate*, *SktUDPRcv*, *SktUDPSend*, *SktTCPAccept*, *SktTCPConnect*, *SktTCPRcv*, *SktTCPSend*, *SktGetTCP-Status*, *SktClose*, *SktClearBuf*, and *SktSetOption*.
- An error occurs in the following cases. *Error* will change to TRUE.
 - There is a setting error for the local IP address.
 - The value of a member of *Socket* is outside of the valid range.
 - Data reception is in progress for the socket specified with *Socket*.
 - The socket specified with *Socket* is not connected.
 - The handle specified by *Socket.Handle* does not exist.
 - Data was not received before the time that is specified with *TimeOut* expired.
 - The socket was closed with the *SktClose* instruction.

Sample Programming

Refer to the sample programming that is provided for the *SktTCPConnect* instruction (page 2-1090).

SktTCPSend

The SktTCPSend instruction sends data from a TCP port for the built-in EtherNet/IP.

Instruction	Name	FB/ FUN	Graphic expression	ST expression
SktTCPSend	TCP Socket Send	FB		SktTCPSend_instance(Execute, Socket, SendDat, Size, Done, Busy, Error, ErrorID);

Variables

Name	Meaning	I/O	Description	Valid range	Unit	Default
Socket	Socket	Input	Socket	---	---	---
SendDat[] (array)	Send data		Send data	Depends on data type.		
Size	Send data size		Send data size	0 to 2000	Bytes	1

	Boolean	Bit strings				Integers							Real numbers	Times, durations, dates, and text strings							
	BOOL	BYTE	WORD	DWORD	LWORD	USINT	UINT	UDINT	ULINT	SINT	INT	DINT	LINT	REAL	LREAL	TIME	DATE	TOD	DT	STRING	
Socket																					
SendDat[] (array)		OK																			
Size							OK														

Function

The SktTCPSend instruction sends send data *SendDat[]* from the socket that is specified with *Socket*. The number of bytes to send is specified with *Size*.

The data type of *Socket* is structure `_sSOCKET`. The specifications are as follows:

Name	Meaning	Description	Data type	Valid range	Unit	Default
Socket	Socket	Socket	<code>_sSOCKET</code>	---	---	---
Handle	Handle	Handle for data communications	UDINT	Depends on data type.	---	0
SrcAdr*	Local address	Local IP address and port number	<code>_sSOCKET_ADDRESS</code>	---	---	---
PortNo*	Port number	Port number	UINT	1 to 65535		0
IpAdr*	IP address	IP address or host name. A DNS or Hosts setting is required to use a host name.	STRING	Depends on data type.	---	,"
DstAdr*	Destination address	Destination IP address and port number	<code>_sSOCKET_ADDRESS</code>	---	---	---
PortNo*	Port number	Port number	UINT	1 to 65535		0
IpAdr*	IP address	IP address or host name. A DNS or Hosts setting is required to use a host name.	STRING	Depends on data type.	---	,"

* These members are not used for this instruction.

Related System-defined Variables

Name	Meaning	Data type	Description
<code>_EIP_EtnOnlineSta</code> *1	Online	BOOL	This variable indicates when built-in EtherNet/IP port communications can be used. TRUE: Communications are possible. FALSE: Communications are not possible.
<code>_EIP1_EtnOnlineSta</code> *2			
<code>_EIP2_EtnOnlineSta</code> *3			
<code>_EIPIn1_EtnOnlineSta</code> *4			

*1 Use this variable name for an NJ-series CPU Unit.

*2 Use this variable name for port 1 on an NX-series CPU Unit, or for an NY-series Controller.

*3 Use this variable name for port 2 on an NX-series CPU Unit.

*4 Use this variable name for the internal port on an NY-series Controller.

Additional Information

Refer to the *NJ/NX-series CPU Unit Built-in EtherNet/IP Port User's Manual* (Cat. No. W506) or *NY-series Industrial Panel PC / Industrial Box PC Built-in EtherNet/IP Port User's Manual* (Cat. No. W563) for details on socket services.

Precautions for Correct Use

- Execution of this instruction is continued until processing is completed even if the value of *Execute* changes to FALSE or the execution time exceeds the task period. The value of *Done* changes to TRUE when processing is completed. Use this to confirm normal completion of processing.
- Refer to *Using this Section* on page 2-3 for a timing chart for *Execute*, *Done*, *Busy*, and *Error*.
- This instruction can be used only for the built-in EtherNet/IP on NJ/NX-series CPU Units and NY-series Controllers.
- Up to 2,000 bytes of data can be sent with one instruction. A maximum of 2,000 bytes is sent even if the *SendDat[]* array is larger than 2,000 bytes.
- Data is not sent if the value of *Size* is 0.

- You can execute a maximum of 32 of the following instructions at the same time: SktUDPCreate, SktUDPRcv, SktUDPSend, SktTCPAccept, SktTCPConnect, SktTCPRcv, SktTCPSend, SktGetTCP-Status, SktClose, SktClearBuf, and SktSetOption.
- An error occurs in the following cases. *Error* will change to TRUE.
 - There is a setting error for the local IP address.
 - The value of a member of *Socket* is outside of the valid range.
 - Data transmission is in progress for the socket specified with *Socket*.
 - The socket specified with *Socket* is not connected.
 - The handle specified by *Socket.Handle* does not exist.

Sample Programming

Refer to the sample programming that is provided for the SktTCPConnect instruction (page 2-1090).

SktGetTCPStatus

The SktGetTCPStatus instruction reads the status of a TCP socket.

Instruction	Name	FB/ FUN	Graphic expression	ST expression
SktGetTCP Status	Read TCP Socket Status	FB		SktGetTCPStatus_instance(Execute, Socket, Done, Busy, Error, ErrorID, TcpStatus, DatRcvFlag);

Variables

Name	Meaning	I/O	Description	Valid range	Unit	Default
Socket	Socket	Input	Socket	---	---	---
TcpStatus	TCP connection status	Output	TCP connection status	*	---	---
DatRcvFlag	Data Received Flag		TRUE: Data is received. FALSE: Data is not received.	Depends on data type.		

* _CLOSED, _LISTEN, _SYN_SENT, _SYN_RECEIVED, _ESTABLISHED, _CLOSE_WAIT, _FIN_WAIT1, _CLOSING, _LAST_ACK, _FIN_WAIT2, or _TIME_WAIT

	Boolean	Bit strings				Integers							Real numbers	Times, durations, dates, and text strings							
	BOOL	BYTE	WORD	DWORD	LWORD	USINT	UINT	UDINT	ULINT	SINT	INT	DINT	LINT	REAL	LREAL	TIME	DATE	TOD	DT	STRING	
Socket																					Refer to <i>Function</i> for details on the structure _sSOCKET.
TcpStatus																					Refer to <i>Function</i> for the enumerators of the enumerated type _eCONNECTION_STATE.
DatRcvFlag	OK																				

Function

The SktGetTCPStatus instruction gets the TCP connection status *TcpStatus* of the socket that is specified with *Socket*. If there is receive data in the receive buffer, the value of data received flag *DatRcvFlag* changes to TRUE. Storage of the data to *TcpStatus* and *DatRcvFlag* is completed when the instruction is completed normally (i.e., when the value of *Done* changes to TRUE).

The data type of *Socket* is structure `_sSOCKET`. The specifications are as follows:

Name	Meaning	Description	Data type	Valid range	Unit	Default
Socket	Socket	Socket	<code>_sSOCKET</code>	---	---	---
Handle	Handle	Handle for data communications	UDINT	Depends on data type.	---	0
SrcAdr*	Local address	Local IP address and port number	<code>_sSOCKET_ADDRESS</code>	---	---	---
PortNo*	Port number	Port number	UINT	1 to 65535		0
IpAdr*	IP address	IP address or host name. A DNS or Hosts setting is required to use a host name.	STRING	Depends on data type.	---	,
DstAdr*	Destination address	Destination IP address and port number	<code>_sSOCKET_ADDRESS</code>	---	---	---
PortNo*	Port number	Port number	UINT	1 to 65535		0
IpAdr*	IP address	IP address or host name. A DNS or Hosts setting is required to use a host name.	STRING	Depends on data type.	---	,

* These members are not used for this instruction.

The data type of *TcpStatus* is enumerated type `_eCONNECTION_STATE`. The meanings of the enumerators of enumerated type `_eCONNECTION_STATE` are as follows:

Enumerators	Meaning
<code>_CLOSED</code>	CLOSED status
<code>_LISTEN</code>	LISTEN status
<code>_SYN_SENT</code>	SYN SENT status
<code>_SYN_RECEIVED</code>	SYN RECEIVED status
<code>_ESTABLISHED</code>	ESTABLISHED status
<code>_CLOSE_WAIT</code>	CLOSE WAIT status
<code>_FIN_WAIT1</code>	FIN WAIT1 status
<code>_CLOSING</code>	CLOSING status
<code>_LAST_ACK</code>	LAST ACK status
<code>_FIN_WAIT2</code>	FIN WAIT2 status
<code>_TIME_WAIT</code>	TIME WAIT status

Related System-defined Variables

Name	Meaning	Data type	Description
<code>_EIP_EtnOnlineSta</code> *1	Online	BOOL	This variable indicates when built-in EtherNet/IP port communications can be used. TRUE: Communications are possible. FALSE: Communications are not possible.
<code>_EIP1_EtnOnlineSta</code> *2			
<code>_EIP2_EtnOnlineSta</code> *3			
<code>_EIPIn1_EtnOnlineSta</code> *4			

*1 Use this variable name for an NJ-series CPU Unit.

*2 Use this variable name for port 1 on an NX-series CPU Unit, or for an NY-series Controller.

*3 Use this variable name for port 2 on an NX-series CPU Unit.

*4 Use this variable name for the internal port on an NY-series Controller.

Additional Information

Refer to the *NJ/NX-series CPU Unit Built-in EtherNet/IP Port User's Manual* (Cat. No. W506) or *NY-series Industrial Panel PC / Industrial Box PC Built-in EtherNet/IP Port User's Manual* (Cat. No. W563) for details on socket services.

Precautions for Correct Use

- Execution of this instruction is continued until processing is completed even if the value of *Execute* changes to FALSE or the execution time exceeds the task period. The value of *Done* changes to TRUE when processing is completed. Use this to confirm normal completion of processing.
- Refer to *Using this Section* on page 2-3 for a timing chart for *Execute*, *Done*, *Busy*, and *Error*.
- This instruction can be used only for the built-in EtherNet/IP on NJ/NX-series CPU Units and NY-series Controllers.
- You can execute a maximum of 32 of the following instructions at the same time: SktUDPCreate, SktUDPRcv, SktUDPSend, SktTCPAccept, SktTCPConnect, SktTCPRcv, SktTCPSend, SktGetTCPStatus, SktClose, SktClearBuf, and SktSetOption.
- An error occurs in the following cases. *Error* will change to TRUE.
 - The value of a member of *Socket* is outside of the valid range.
 - The handle specified by *Socket.Handle* does not exist.

Sample Programming

Refer to the sample programming that is provided for the SktTCPConnect instruction (page 2-1090).

SktClose

The SktClose instruction closes the specified TCP or UDP socket for the built-in EtherNet/IP.

Instruction	Name	FB/ FUN	Graphic expression	ST expression
SktClose	Close TCP/UDP Socket	FB	<pre> SktClose_instance ┌───────────┐ │ SktClose │ │ ── Execute ── Done ──> │ ── Socket ── Busy ──> │ ── Error ──> │ ── ErrorID ──> └───────────┘ </pre>	SktClose_instance(Execute, Socket, Done, Busy, Error, ErrorID);

Variables

Name	Meaning	I/O	Description	Valid range	Unit	Default
Socket	Socket	Input	Socket	---	---	---

	Boolean	Bit strings					Integers							Real numbers	Times, durations, dates, and text strings					
	BOOL	BYTE	WORD	DWORD	LWORD	USINT	UINT	UDINT	ULINT	SINT	INT	DINT	LINT	REAL	LREAL	TIME	DATE	TOD	DT	STRING
Socket		Refer to <i>Function</i> for details on the structure <code>_sSOCKET</code> .																		

Function

The SktClose instruction closes the socket that is specified with *Socket*. If a TCP socket is specified, the socket is disconnected before it is closed. If the socket handle *Socket.Handle* is 0, all TCP and UDP ports that currently use the socket service are closed. Close processing for the TCPUDP sockets is completed when the instruction is completed normally (i.e., when the value of *Done* changes to TRUE).

The data type of *Socket* is structure `_sSOCKET`. The specifications are as follows:

Name	Meaning	Description	Data type	Valid range	Unit	Default
Socket	Socket	Socket	<code>_sSOCKET</code>	---	---	---
Handle	Handle	Handle of the connection to close. 0: Closes all TCP connections that currently use the socket service.	UDINT	Depends on data type.	---	0
SrcAdr*	Local address	Local IP address and port number	<code>_sSOCKET_ADDRESS</code>	---	---	---
PortNo*	Port number	Port number	UINT	1 to 65535		0
IpAdr*	IP address	IP address or host name. A DNS or Hosts setting is required to use a host name.	STRING	Depends on data type.	---	''
DstAdr*	Destination address	Destination IP address and port number	<code>_sSOCKET_ADDRESS</code>	---	---	---
PortNo*	Port number	Port number	UINT	1 to 65535		0
IpAdr*	IP address	IP address or host name. A DNS or Hosts setting is required to use a host name.	STRING	Depends on data type.	---	''

* These members are not used for this instruction.

Related System-defined Variables

Name	Meaning	Data type	Description
<code>_EIP_EtnOnlineSta</code> *1	Online	BOOL	This variable indicates when built-in EtherNet/IP port communications can be used. TRUE: Communications are possible. FALSE: Communications are not possible.
<code>_EIP1_EtnOnlineSta</code> *2			
<code>_EIP2_EtnOnlineSta</code> *3			
<code>_EIPIn1_EtnOnlineSta</code> *4			

*1 Use this variable name for an NJ-series CPU Unit.

*2 Use this variable name for port 1 on an NX-series CPU Unit, or for an NY-series Controller.

*3 Use this variable name for port 2 on an NX-series CPU Unit.

*4 Use this variable name for the internal port on an NY-series Controller.

Additional Information

Refer to the *NJ/NX-series CPU Unit Built-in EtherNet/IP Port User's Manual* (Cat. No. W506) or *NY-series Industrial Panel PC / Industrial Box PC Built-in EtherNet/IP Port User's Manual* (Cat. No. W563) for details on socket services.

Precautions for Correct Use

- Execution of this instruction is continued until processing is completed even if the value of *Execute* changes to FALSE or the execution time exceeds the task period. The value of *Done* changes to TRUE when processing is completed. Use this to confirm normal completion of processing.
- Refer to *Using this Section* on page 2-3 for a timing chart for *Execute*, *Done*, *Busy*, and *Error*.
- This instruction can be used only for the built-in EtherNet/IP on NJ/NX-series CPU Units and NY-series Controllers.

- If the `SktUDPRcv` or `SktTCPRcv` instruction is executed and then the `SktClose` instruction is executed while the socket for the specified handle is on standby to received data, the standby status is canceled.
- If more than one connection is open for the same local port number, only the connection for the specified socket is closed.
- If the value of the socket handle `Socket.Handle` is 0, all connections that are on standby for the `SktTCPAccept` instruction are canceled.
- You can execute a maximum of 32 of the following instructions at the same time: `SktUDPCreate`, `SktUDPRcv`, `SktUDPSend`, `SktTCPAccept`, `SktTCPConnect`, `SktTCPRcv`, `SktTCPSend`, `SktGetTCPStatus`, `SktClose`, `SktClearBuf`, and `SktSetOption`.
- An error occurs in the following cases. `Error` will change to `TRUE`.
 - There is a setting error for the local IP address.
 - The value of a member of `Socket` is outside of the valid range.
 - The handle specified by `Socket.Handle` does not exist.

Sample Programming

Refer to the sample programming for the following instructions: `SktUDPCreate` (page 2-1073) and `SktTCPConnect` (page 2-1090).

SktClearBuf

The SktClearBuf instruction clears the receive buffer for the specified TCP or UDP socket for the built-in EtherNet/IP.

Instruction	Name	FB/ FUN	Graphic expression	ST expression
SktClearBuf	Clear TCP/UDP Socket Receive Buffer	FB		SktClearBuf_instance(Execute, Socket, Done, Busy, Error, ErrorID);

Variables

Name	Meaning	I/O	Description	Valid range	Unit	Default
Socket	Socket	Input	Socket	---	---	---

	Boolean	Bit strings					Integers							Real numbers	Times, durations, dates, and text strings						
		BOOL	BYTE	WORD	DWORD	LWORD	USINT	UINT	UDINT	ULINT	SINT	INT	DINT		LINT	REAL	LREAL	TIME	DATE	TOD	DT
Socket		Refer to <i>Function</i> for details on the structure <code>_sSOCKET</code> .																			

Function

The SktClearBuf instruction clears the receive buffer for the socket that is specified with *Socket*. Clear processing of the receive buffer is completed when the instruction is completed normally (i.e., when the value of *Done* changes to TRUE).

The data type of *Socket* is structure `_sSOCKET`. The specifications are as follows:

Name	Meaning	Description	Data type	Valid range	Unit	Default
Socket	Socket	Socket	<code>_sSOCKET</code>	---	---	---
Handle	Handle	The handle of the socket to clear the receive buffer	UDINT	Depends on data type.	---	0
SrcAdr*	Local address	Local IP address and port number	<code>_sSOCKET_ADDRESS</code>	---	---	---
PortNo*	Port number	Port number	UINT	1 to 65535	---	0
IpAdr*	IP address	IP address or host name. A DNS or Hosts setting is required to use a host name.	STRING	Depends on data type.		,
DstAdr*	Destination address	Destination IP address and port number	<code>_sSOCKET_ADDRESS</code>	---	---	---
PortNo*	Port number	Port number	UINT	1 to 65535	---	0
IpAdr*	IP address	IP address or host name. A DNS or Hosts setting is required to use a host name.	STRING	Depends on data type.		,

* These members are not used for this instruction.

Related System-defined Variables

Name	Meaning	Data type	Description
<code>_EIP_EtnOnlineSta</code> *1	Online	BOOL	This variable indicates when built-in EtherNet/IP port communications can be used. TRUE: Communications are possible. FALSE: Communications are not possible.
<code>_EIP1_EtnOnlineSta</code> *2			
<code>_EIP2_EtnOnlineSta</code> *3			
<code>_EIPIn1_EtnOnlineSta</code> *4			

*1 Use this variable name for an NJ-series CPU Unit.

*2 Use this variable name for port 1 on an NX-series CPU Unit, or for an NY-series Controller.

*3 Use this variable name for port 2 on an NX-series CPU Unit.

*4 Use this variable name for the internal port on an NY-series Controller.

Additional Information

Refer to the *NJ/NX-series CPU Unit Built-in EtherNet/IP Port User's Manual* (Cat. No. W506) or *NY-series Industrial Panel PC / Industrial Box PC Built-in EtherNet/IP Port User's Manual* (Cat. No. W563) for details on socket services.

Precautions for Correct Use

- Execution of this instruction is continued until processing is completed even if the value of *Execute* changes to FALSE or the execution time exceeds the task period. The value of *Done* changes to TRUE when processing is completed. Use this to confirm normal completion of processing.
- Refer to *Using this Section* on page 2-3 for a timing chart for *Execute*, *Done*, *Busy*, and *Error*.
- This instruction can be used only for the built-in EtherNet/IP on NJ/NX-series CPU Units and NY-series Controllers.
- You can execute a maximum of 32 of the following instructions at the same time: *SktUDPCreate*, *SktUDPRcv*, *SktUDPSend*, *SktTCPAccept*, *SktTCPConnect*, *SktTCPRcv*, *SktTCPSend*, *SktGetTCPStatus*, *SktClose*, *SktClearBuf*, and *SktSetOption*.
- An error occurs in the following cases. *Error* will change to TRUE.
 - The value of a member of *Socket* is outside of the valid range.

- The socket that is specified by *Socket* does not exist.
- The handle specified by *Socket.Handle* does not exist.

Sample Programming

Refer to the sample programming that is provided for the SktTCPConnect instruction (page 2-1090).

SktSetOption

The SktSetOption instruction sets the option for TCP socket specified for the built-in EtherNet/IP.

Instruction	Name	FB/ FUN	Graphic expression	ST expression
SktSetOption	Set TCP Socket Option	FB		SktSetOption_instance(Execute, Socket, OptionType, OptionParam, Done, Busy, Error, ErrorID);



Version Information

A CPU Unit with unit version 1.12 or later and Sysmac Studio version 1.16 or higher are required to use this instruction.

For an NX1P2 CPU Unit, a CPU Unit with unit version 1.14 or later and Sysmac Studio 1.18 or higher are required to use this instruction.

Variables

Name	Meaning	I/O	Description	Valid range	Unit	Default
Socket	Socket	Input	Socket	---	---	---
OptionType	Option type		Type of socket option	---	---	---
OptionParam	Option parameter		Setting parameters according to the specified socket option	---	---	---

	Boolean	Bit strings					Integers							Real numbers		Times, durations, dates, and text strings				
	BOOL	BYTE	WORD	DWORD	LWORD	USINT	UINT	UDINT	ULINT	SINT	INT	DINT	LINT	REAL	LREAL	TIME	DATE	TOD	DT	STRING
Socket		Refer to <i>Function</i> for details on the structure <code>_sSOCKET</code> .																		
OptionType		Refer to <i>Function</i> for the enumerators of the enumerated type <code>_eSKT_OPTION_TYPE</code> .																		
OptionParam	OK*1																			

*1 A constant (literal) cannot be input. Specify a variable.

Function

The SktSetOption instruction sets the socket option for the socket specified with *Socket*.

Done changes to TRUE when processing of the instruction is completed normally.

The socket option setting is completed when processing of the instruction is completed normally.

The data type of Socket is structure `_sSOCKET`. The specifications are as follows:

Name	Meaning	Description	Data type	Valid range	Unit	Default
Socket	Socket	Socket	<code>_sSOCKET</code>	---	---	---
Handle	Handle	The handle of the socket to clear the receive buffer	UDINT	Depends on data type.	---	0
SrcAdr(*)	Local address	Local IP address and port number	<code>_sSOCKET_ADDRESS</code>	---	---	---
PortNo(*)	Port number	Port number	UINT	1 to 65,535		0
IpAdr(*)	IP address	IP address or host name. A DNS or Hosts setting is required to use a host name.	STRING	Depends on data type.	---	''
DstAdr(*)	Destination address	Destination IP address and port number	<code>_sSOCKET_ADDRESS</code>	---	---	---
PortNo(*)	Port number	Port number	UINT	1 to 65,535		0
IpAdr(*)	IP address	IP address or host name. A DNS or Hosts setting is required to use a host name.	STRING	Depends on data type.	---	''

* These members are not used for this instruction.

The following table shows the value of *OptionType* that you can specify and the data type of *OptionParam* that you can select for the specified *OptionType*. Also, the default operation when this instruction is not used is given by the default value below.

OptionType		OptionParam		
Enumerator	Meaning	Selectable data type	Meaning of value	Default
<code>_TCP_NODELAY</code>	Specifies the <code>TCP_NODELAY</code> option. It can be used only for TCP socket.	BOOL	TRUE*1 : <code>TCP_NODELAY</code> option enabled FALSE: <code>TCP_NODELAY</code> option disabled	FALSE

*1 When it is set to TRUE, the Nagle algorithm is disabled. With this setting, even small data is not transmitted collectively.

Related System-defined Variables

Name	Meaning	Data type	Description
_EIP_EtnOnlineSta *1	Online	BOOL	This variable indicates when built-in EtherNet/IP port communications can be used. TRUE: Communications are possible. FALSE: Communications are not possible.
_EIP1_EtnOnlineSta *2			
_EIP2_EtnOnlineSta *3			
_EIPIn1_EtnOnlineSta *4			

*1 Use this variable name for an NJ-series CPU Unit.

*2 Use this variable name for port 1 on an NX-series CPU Unit, or for an NY-series Controller.

*3 Use this variable name for port 2 on an NX-series CPU Unit.

*4 Use this variable name for the internal port on an NY-series Controller.

Additional Information

Refer to the *NJ/NX-series CPU Unit Built-in EtherNet/IP Port User's Manual* (Cat. No. W506) or the *NY-series Industrial Panel PC / Industrial Box PC Built-in EtherNet/IP Port User's Manual* (Cat. No. W563) for details on the socket service functions.

Precautions for Correct Use

- Execution of this instruction is continued until processing is completed even if the value of *Execute* changes to FALSE or the execution time exceeds the task period. The value of *Done* changes to TRUE when processing is completed. Use this to confirm normal completion of processing.
- Refer to *Using this Section* on page 2-3 for a timing chart for *Execute*, *Done*, *Busy*, and *Error*.
- This instruction can be used only for the built-in EtherNet/IP on the NJ/NX-series CPU Units and on the NY-series Controllers.
- You can use this instruction after the socket handle is opened by the *SktTCPAccept*, or *SktTCPConnect* instruction and before data transmission is started by *SktTCPRcv*, *SktTCPSend*, or *SktClearBuf* instruction. An error will occur if you execute this instruction after data transmission is started.
- You must set the socket option for each handle specified with *Socket*. The socket option that was set is enabled while the handle is open. After closing the handle with the *SktClose* instruction, execute the *SktTCPAccept* and *SktTCPConnect* instructions again to open the handle, and then execute this instruction to set the socket option.
- You can execute a maximum of 32 of the following instructions at the same time: *SktUDPCreate*, *SktUDPRcv*, *SktUDPSend*, *SktTCPAccept*, *SktTCPConnect*, *SktTCPRcv*, *SktTCPSend*, *SktGetTCPStatus*, *SktClose*, *SktClearBuf*, and *SktSetOption*.
- An error will occur in the following cases. *Error* will change to TRUE.
 - The value of a member of *Socket* is outside of the valid range.
 - The data type specified for *OptionParam* is not supported by *OptionType*.
 - The specified handle socket already started transmission.
 - The specified socket type is not supported by the handle type. Such a case includes when the *TCP_NODELAY* is executed for UDP socket.
 - The handle specified by *Socket.Handle* does not exist.

Sample Programming

ST

Internal Variables	Variable	Data type	Initial value	Comment
	Trigger	BOOL	FALSE	Execution condition
	DoTCP	BOOL	FALSE	Processing
	Stage	INT	0	State transition
	WkSocket	_sSOCKET	(Handle:=0, SrcAdr:=(PortNo:=0,IpAdr:="), DstAdr:=(PortNo:=0,IpAdr:="))	Socket
	SendSocketDat	ARRAY[0..1999] OF BYTE		Send data
	Nodelay	BOOL	TRUE	<i>NoDelay</i> setting
	SkdTCPConnect_instance	SkdTCPConnect		
	SkdSetOption_instance	SkdSetOption		
	SkdTCPSend_instance	SkdTCPSend		
	SkdClose_instance	SkdClose		

```
// Start sequence when Trigger changes to TRUE.
IF ((Trigger=TRUE) AND (DoTCP=FALSE) AND (_EIP_EtnOnlineSta=TRUE)) THEN
  DoTCP:=TRUE;
  Nodelay:=TRUE;
  Stage:=INT#1;
  SkdTCPConnect_instance(Execute:=FALSE); // Initialize instance.
  SkdSetOption_instance( // Initialize instance.
    Execute:=FALSE,
    OptionType:=_TCP_NODELAY,
    OptionParam:= Nodelay);
  SkdSetOption_instance(Execute:=FALSE); // Initialize instance.
  SkdTCPSend_instance( // Initialize instance.
    Execute:=FALSE,
    SendDat:=SendSocketDat[0]); // Dummy
  SkdClose_instance(Execute:=FALSE); // Initialize instance.
END_IF;

IF (DoTCP=TRUE) THEN
  CASE Stage OF
  1 : // Request a connection.
    SkdTCPConnect_instance(
      Execute:=TRUE,
      SrcTcpPort:=UINT#0, // Local UDP port number: Automatically
      assigned.
      DstAdr:='192.168.250.2', // Remote IP address
      DstTcpPort:=UINT#6000, // Destination TCP port number
      Socket =>WkSocket); // Socket
    IF (SkdTCPConnect_instance.Done=TRUE) THEN
      Stage:=INT#2; // Normal end
    ELSIF (SkdTCPConnect_instance.Error=TRUE) THEN
      Stage:= INT#10; // Error end
    
```

```

        END_IF;

2 :// Set Socket Option
  SktSetOption_instance(
    Execute:=TRUE,
    Socket:=WkSocket); // Socket
    OptionType:=_TCP_NODELAY, // Option type
    OptionParam:= Nodelay); // NODELAY enabled
  IF (SktSetOption_instance.Done=TRUE) THEN
    Stage:=INT#3; // Normal end
  ELSIF (SktSetOption_instance.Error=TRUE) THEN
    Stage:=INT#20; // Error end
  END_IF;

3 :// Send request
  SktTCPSend_instance(
    Execute:=TRUE,
    Socket:=WkSocket); // Socket
    SendDat:=SendSocketDat[0], // Send data
    Size:=UINT#2000); // Send data size
  IF (SktTCPSend_instance.Done=TRUE) THEN
    Stage:=INT#4; // Normal end
  ELSIF (SktTCPSend_instance.Error=TRUE) THEN
    Stage:= INT#30; // Error end
  END_IF;

4 :// Request closing data.
  SktClose_instance(
    Execute:=TRUE,
    Socket:=WkSocket); // Socket
  IF (SktClose_instance.Done=TRUE) THEN
    Stage:=INT#0; // Normal end
  ELSIF (SktClose_instance.Error=TRUE) THEN
    Stage:= INT#40; // Error end
  END_IF;

0 :// Normal end
  DoTCP:=FALSE;
  Trigger:=FALSE;

  ELSE// Interrupted by error.
    DoTCP:=FALSE;
    Trigger:=FALSE;
  END_CASE;
END_IF;

```

ChangeIPAdr

The ChangeIPAdr instruction changes the IP address of the built-in EtherNet/IP port on a CPU Unit or the IP address of an EtherNet/IP Unit.

Instruction	Name	FB/ FUN	Graphic expression	ST expression
ChangeIPAdr	Change IP Address	FB	<pre> graph LR subgraph ChangeIPAdr_instance [ChangeIPAdr_instance] subgraph ChangeIPAdr [ChangeIPAdr] Execute --- In_Execute UnitNo --- In_UnitNo BootPControl --- In_BootPControl IPAdr --- In_IPAdr SubnetMask --- In_SubnetMask DefaultGateway --- In_DefaultGateway Done --- Out_Done Busy --- Out_Busy Error --- Out_Error ErrorID --- Out_ErrorID end end </pre>	ChangeIPAdr_instance(Execute, UnitNo, BootPControl, IPAdr, SubnetMask, DefaultGateway, Done, Busy, Error, ErrorID);

Variables

Name	Meaning	I/O	Description	Valid range	Unit	Default
UnitNo	Unit number	Input	Unit number for which to change the IP address	_CBU_CPU * ¹ , _CBU_CPU_P ort1 * ² , _CBU_CPU_P ort2 * ³ , _CBU_CPU_In Port1 * ⁴ , or _CBU_No00 to _CBU_No15 * ⁵	---	_CBU_No00
BootP Control	IP address assignment method and setting timing		Method to obtain the IP address and the setting timing	0 to 3 * ⁶		0
IPAdr[] (array)* ⁷	IP address		IP address	* ⁸		---
Subnet Mask[] (array)* ⁷	Subnet mask		Subnet mask			
Default Gateway[] (array)* ⁷	Default gateway		Default gateway			

*1 Specification is possible for an NJ-series CPU Unit.

*2 Specification is possible for port 1 on an NX-series CPU Unit or an NY-series Controller. You can specify _CBU_CPU instead of _CBU_CPU_Port1.

*3 Specification is possible for port 2 on an NX-series CPU Unit.

*4 Specification is possible for an NY-series Controller.

*5 Specification is possible for an NJ-series CPU Unit.

*6 The range is 0 to 2 for port 1 on an NX-series CPU Unit, for NJ-series CPU Unit, and for an NY-series Controller; 0 to 3 for port 2 on an NX-series CPU Unit; and 0 for the internal port on an NY-series Controller.

*7 This is a 4-element array with element numbers 0 to 3.

*8 The valid range depends on whether you specify the built-in EtherNet/IP port or an EtherNet/IP Unit for *UnitNo* (Unit number). Refer to *Function*, below, for details.

	Boolean	Bit strings				Integers							Real numbers		Times, durations, dates, and text strings					
	BOOL	BYTE	WORD	DWORD	LWORD	USINT	UINT	UDINT	ULINT	SINT	INT	DINT	LINT	REAL	LREAL	TIME	DATE	TOD	DT	STRING
UnitNo	Refer to <i>Function</i> for the enumerators of the enumerated type <code>_eUnitNo</code> .																			
BootP Control							OK													
IPAdr[] (array)		OK																		
	Specify an array.																			
Subnet Mask[] (array)		OK																		
	Specify an array.																			
BootP Control		OK																		
Default Gateway[] (array)	Specify an array.																			

Function

The `ChangeIPAdr` instruction changes the IP address of the built-in EtherNet/IP port, internal port, or EtherNet/IP Unit that is specified with *UnitNo* (Unit number) according to IP address assignment method and setting timing *BootPControl*.

If you specify the built-in EtherNet/IP port with *UnitNo*, the port goes to link OFF status when execution of the instruction ends and then goes to link ON status with the new IP address.

If the internal port is specified with *UnitNo*, the `_EIPIn1_EtnOnlineSta` system-defined variable changes to FALSE when execution of the instruction ends. Communications with the new IP address is enabled when the variable changes to TRUE. If you specify an EtherNet/IP Unit with *UnitNo*, the EtherNet/IP Unit is restarted when execution of the instruction ends. Communications with the new IP address is enabled when restarting the Unit ends.

You can use this instruction to change the IP address of the built-in EtherNet/IP port, internal port, or an EtherNet/IP Unit from an HMI.

The data type of *UnitNo* is enumerated type `_eUnitNo`. The meanings of the enumerators are as follows:

Enumerator	Meaning
<code>_CBU_CPU*1</code>	Built-in EtherNet/IP port
<code>_CBU_CPU_Port1*2</code>	Built-in EtherNet/IP communications port 1
<code>_CBU_CPU_Port2*3</code>	Built-in EtherNet/IP communications port 2
<code>_CBU_CPU_InPort1*4</code>	Internal port 1
<code>_CBU_No00 to _CBU_No15*5</code>	Unit number 00 to 15 of the EtherNet/IP Unit

*1 Specification is possible for an NJ-series CPU Unit.

*2 Specification is possible for an NX-series CPU Unit or an NY-series Controller. You can specify `_CBU_CPU` instead of `_CBU_CPU_Port1`.

*3 Specification is possible for an NX-series CPU Unit. You cannot use it for CPU Units without Communications Port 2.

*4 Specification is possible for an NY-series Controller.

*5 Specification is possible for an NJ-series CPU Unit.

The value of *BootPControl* determines how to obtain the new IP address and when to set it, as described in the following table.

For *BootPControl*, you can specify a value in the range of 0 to 2 for port 1 on an NX-series CPU Unit, for NJ-series CPU Unit, and for an NY-series Controller. The range is 0 to 3 for port 2 on an NX-series CPU Unit. You can specify only 0 for internal port on an NY-series Controller.

Value of <i>BootPControl</i>	Method to obtain the IP address	When to change the IP address
0	The IP address is obtained from IP address <i>IPAddr[]</i> , subnet mask <i>SubnetMask[]</i> , and default gateway <i>DefaultGateway[]</i> .	The IP address is set only once each time the instruction is executed (fixed setting).
1	The IP address is obtained from the BOOTP server.	The IP address is set once when the instruction is executed and then once each time the power supply to the Controller is turned ON.
2	The IP address is obtained from the BOOTP server.	The IP address is set only once each time the instruction is executed (fixed setting).
3	The port is set to an unused port. Any existing IP address is deleted.	The IP address is set only once each time the instruction is executed (fixed setting).

Set the IP address, subnet mask, and default gateway in order in elements 0 to 3 of *IPAddr[]*, *SubnetMask[]*, and *DefaultGateway[]*. For example, if the new IP address is 130.58.17.32, set *IPAddr[0]* to BYTE#16#82, *IPAddr[1]* to BYTE#16#3A, *IPAddr[2]* to BYTE#16#11 and *IPAddr[3]* to BYTE#16#20.

The valid ranges of *IPAddr[]*, *SubnetMask[]*, and *DefaultGateway[]* depend on whether you specify the built-in EtherNet/IP port or an EtherNet/IP Unit for *UnitNo*, as shown below. The valid ranges of the values are valid only when the value of *BootPControl* is set to 0.

Setting of <i>UnitNo</i>	Input variable	Valid range
Built-in EtherNet/IP port Internal port	<i>IPAddr[]</i> (array)	The following IP addresses cannot be used. All other IP addresses are valid. <ul style="list-style-type: none"> IP addresses that start with 127, 0, or 255 IP addresses with a host ID for which all bits are 0's or for which all bits are 1's Class D IP addresses (224.0.0.0 to 239.255.255.255) Class E IP addresses (240.0.0.0 to 255.255.255.255) IP addresses that are reserved for AutoIP*1 (169.254.0.0 to 169.254.255.255) IP addresses of USB ports (192.168.255.0 to 192.168.255.255)*2
	<i>SubnetMask[]</i> (array)	192.0.0.0 to 255.255.255.252
	<i>DefaultGateway[]</i> (array)	The following IP addresses cannot be used. All other IP addresses are valid. <ul style="list-style-type: none"> IP addresses that start with 127, 0, or 255 There is only one address for which all bits are 1's Class D addresses (224.0.0.0 to 239.255.255.255) Class E IP addresses (240.0.0.0 to 255.255.255.255) IP addresses that are reserved for AutoIP*1 (169.254.0.0 to 169.254.255.255) IP addresses of USB ports (192.168.255.0 to 192.168.255.255)*2

Setting of UnitNo	Input variable	Valid range
EtherNet/IP Unit	IPAdr[] (array)	The following IP addresses cannot be used. All other IP addresses are valid. <ul style="list-style-type: none"> • IP addresses that start with 127 • Class D IP addresses (224.0.0.0 to 239.255.255.255) • Class E IP addresses (240.0.0.0 to 255.255.255.255)
	SubnetMask[] (array)	<ul style="list-style-type: none"> • 0.0.0.0 • 192.0.0.0 to 255.255.255.252
	DefaultGateway[] (array)	The following IP addresses cannot be used. All other IP addresses are valid. <ul style="list-style-type: none"> • IP addresses that start with 127 • Class D IP addresses (224.0.0.0 to 239.255.255.255) • Class E IP addresses (240.0.0.0 to 255.255.255.255)

*1 AutoIP is an automatic IP address assignment feature of Windows 98 and later operating systems.

*2 NX1P2 CPU Units and NY-series Controllers have no USB port.

The values of *IPAdr[]*, *SubnetMask[]*, and *DefaultGateway[]* are ignored when the value of *BootPControl* is 1 or 2. Therefore, the values of *IPAdr[]*, *SubnetMask[]*, and *DefaultGateway[]* can be outside of the valid ranges.

If you specify the built-in EtherNet/IP port for *UnitNo*, you can use the *_EIP_EtnOnlineSta*, *_EIP1_EtnOnlineSta*, *_EIP2_EtnOnlineSta*, and *_EIPIn1_EtnOnlineSta* system-defined variables to see if communications are possible.

Here, *_EIP_EtnOnlineSta* is used as an example, but this information also applies to *_EIP1_EtnOnlineSta*, *_EIP2_EtnOnlineSta* and *_EIPIn1_EtnOnlineSta*.

When *Busy* changes to FALSE, *_EIP_EtnOnlineSta* changes to FALSE. When communications using the new IP address are enabled, *_EIP_EtnOnlineSta* changes to TRUE.

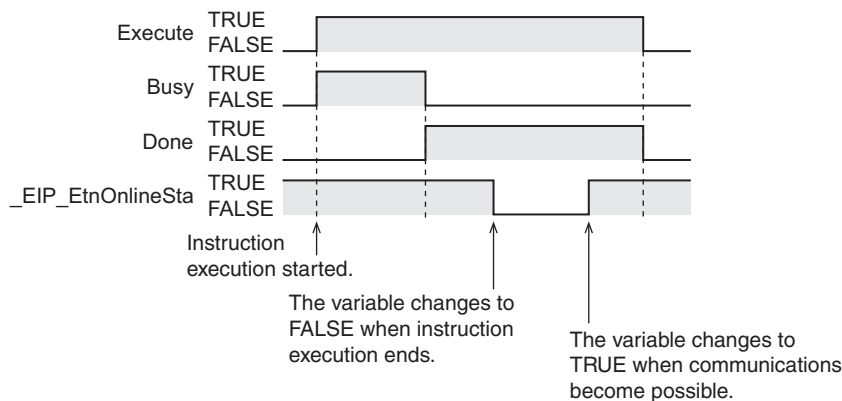

The following example shows how to change the IP address of the EtherNet/IP Unit with unit number 00 to the IP address that is obtained from the BOOTP server each time the instruction is executed. If A (*Execute*) is changed to TRUE from an HMI or other device, the IP address is changed to the IP address that is obtained from the BOOTP server. Then, each time the power supply is turned ON, the IP address is changed to the IP address that is obtained from the BOOTP server.

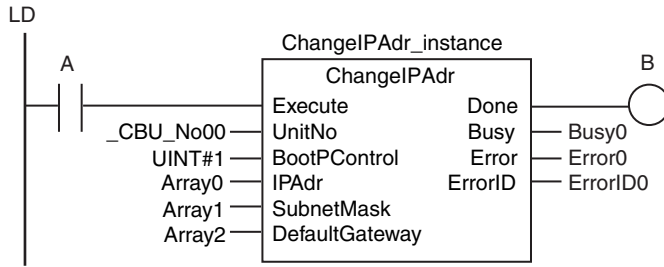

ST

```
ChangeIPAdr_instance(A, _CBU_No00, UINt#1, Array0, Array1, Array2, B, Busy0, Error0, ErrorID0);
```

The IP address that was obtained from the BOOTP server is set for the EtherNet/IP Unit with a unit number of 00. Then, each time the power supply is turned ON, the IP address is reset to the IP address that is obtained from the BOOTP server.

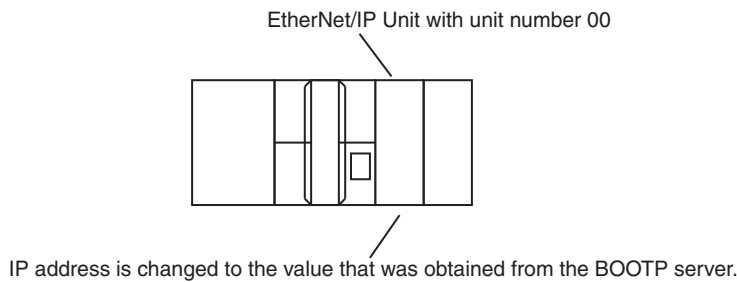

Related System-defined Variables

Name	Meaning	Data type	Description
<u>_EIP_EtnOnlineSta</u> ^{*1}	Online	BOOL	This variable indicates when built-in EtherNet/IP port communications can be used. TRUE: Communications are possible. FALSE: Communications are not possible.
<u>_EIP1_EtnOnlineSta</u> ^{*2}			
<u>_EIP2_EtnOnlineSta</u> ^{*3}			
<u>_EIPIn1_EtnOnlineSta</u> ^{*4}			

*1 Use this variable name for an NJ-series CPU Unit.

*2 Use this variable name for port 1 on an NX-series CPU Unit, or for an NY-series Controller.

*3 Use this variable name for port 2 on an NX-series CPU Unit.

*4 Use this variable name for the internal port on an NY-series Controller.

Additional Information

- If you specify the built-in EtherNet/IP port with *UnitNo*, the following events are recorded in the event log when the instruction is executed.
 - Link OFF Detected
 - IP Address Fixed
- If you specify the internal port with *UnitNo*, the following events are recorded in the event log when the instruction is executed.
 - IP Address Fixed
- You can change the IP address with this instruction even if the CPU Unit is write protected.

Precautions for Correct Use

- Execution of this instruction is continued until processing is completed even if the value of *Execute* changes to FALSE or the execution time exceeds the task period. The value of *Done* changes to TRUE when processing is completed. Use this to confirm normal completion of processing.
- Refer to *Using this Section* on page 2-3 for a timing chart for *Execute*, *Done*, *Busy*, and *Error*.
- If you specify the built-in EtherNet/IP port with *UnitNo*, communications with the built-in EtherNet/IP port will be disabled temporarily when execution of the instruction ends. Confirm that the system will not be adversely affected even if the built-in EtherNet/IP port goes to link OFF status.
- If you specify an EtherNet/IP Unit with *UnitNo*, the EtherNet/IP Unit is restarted when execution of the instruction ends. Confirm that the system will not be adversely affected even if the EtherNet/IP Unit is restarted.
- You cannot use this instruction in an event task. A compiling error will occur.
- *Error* is TRUE if an error occurred. The meanings of the values of *ErrorID* are given in the following table.

Value of <i>ErrorID</i>	Error name	Description
16#0400	Input Value Out of Range	The value of an input variable is outside of the valid range.
16#2400	No Execution Right	The instruction was executed when changing the status was not possible. <ul style="list-style-type: none"> • While changing the settings was already in progress • While restarting the built-in EtherNet/IP port was in progress • While downloading tag data link settings from the Network Configurator was in progress
16#2402	Too Many Simultaneous Instruction Executions	Too many ChangeIPAdr, ChangeFTPAccount, and ChangeNT-PServerAdr instructions were executed at the same time.
16#240D	IP Address Setting Invalid	The network address of the specified port is the same as the network address of another port.



Version Information

A CPU Unit with unit version 1.02 or later and Sysmac Studio version 1.03 or higher are required to use this instruction.

Sample Programming

This sample changes the IP address of the built-in EtherNet/IP port to the following fixed IP address.

Item	Value
IP address	192.168.250.10
Subnet mask	255.255.255.0
Default gateway	0.0.0.0

LD

Variable	Data type	Initial value	Comment
ChangeTrigger	BOOL	False	Change Flag
SettingTrigger	BOOL	False	Changing IP Address Flag
Done0	BOOL	False	IP address changed
Error0	BOOL	False	Error in changing the IP address
Busy0	BOOL	False	Changing IP address
ErrorID0	WORD	16#0	Error ID for changing the IP address

Variable	Data type	Initial value	Comment
NewIPAddress	ARRAY[0..3] OF BYTE	[4(16#0)]	IP address
NewSubnetMask	ARRAY[0..3] OF BYTE	[4(16#0)]	Subnet mask
NewDefaultGateway	ARRAY[0..3] OF BYTE	[4(16#0)]	Default gateway
RS_instance	RS		
ChangeIPAdr_instance	ChangeIPAdr		

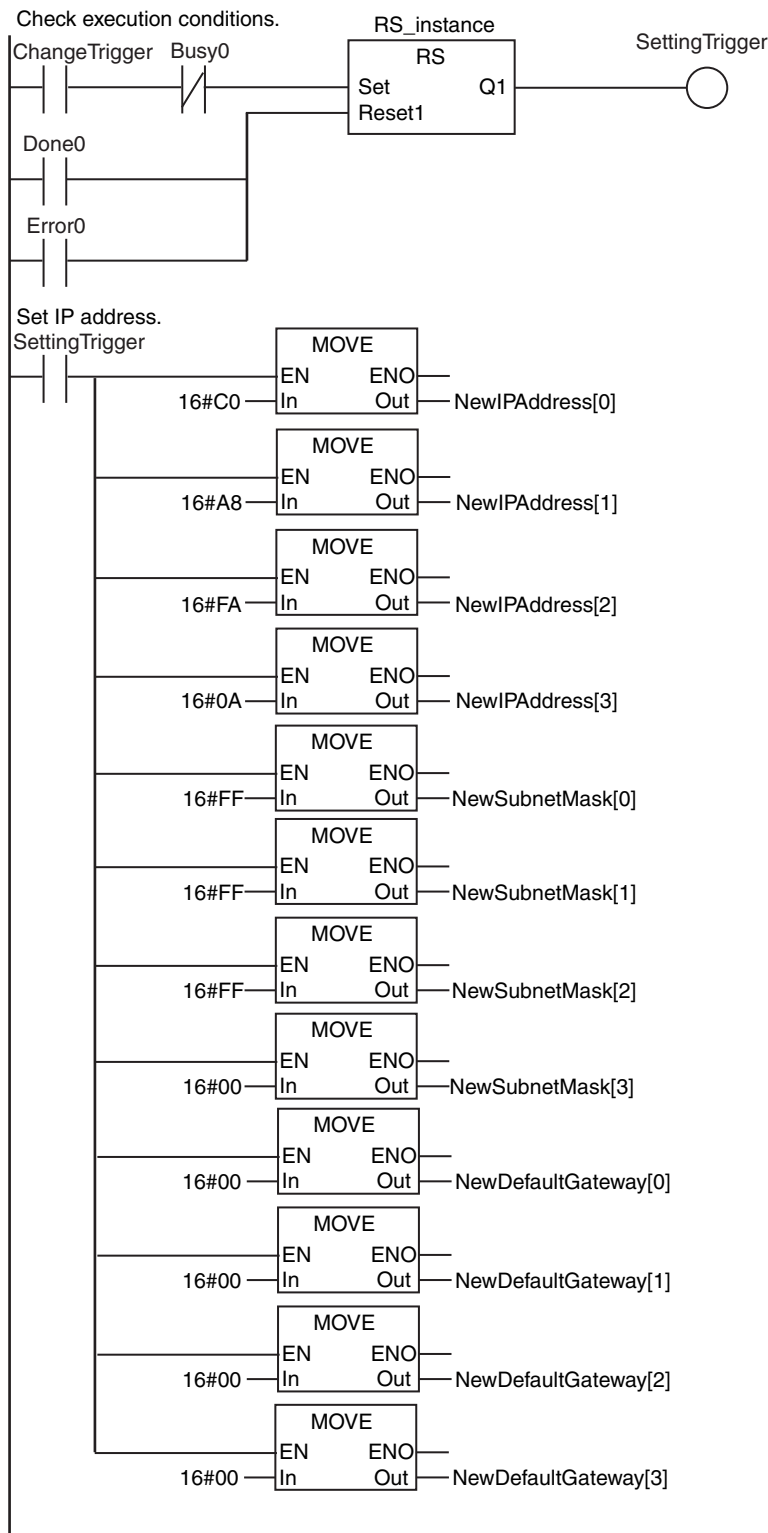

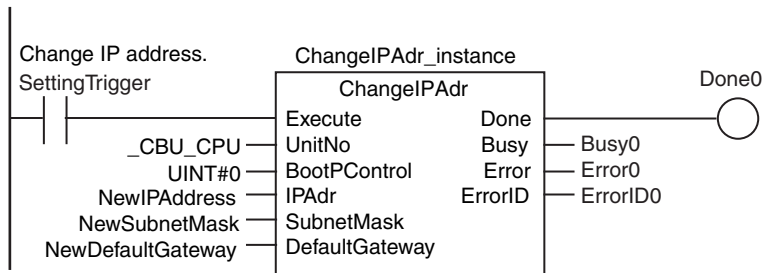

ST

Variable	Data type	Initial value	Comment
ChangeTrigger	BOOL	False	Change Flag
SettingTrigger	BOOL	False	Changing IP Address Flag
Done0	BOOL	False	IP address changed
Error0	BOOL	False	Error in changing the IP address
Busy0	BOOL	False	Changing IP address
ErrorID0	WORD	16#0	Error ID for changing the IP address
NewIPAddress	ARRAY[0..3] OF BYTE	[4(16#0)]	IP address
NewSubnetMask	ARRAY[0..3] OF BYTE	[4(16#0)]	Subnet mask
NewDefaultGateway	ARRAY[0..3] OF BYTE	[4(16#0)]	Default gateway
RS_instance	RS		
ChangeIPAdr_instance	ChangeIPAdr		

```

//Check execution conditions.
IF ((ChangeTrigger=TRUE) AND (Busy0=FALSE)) THEN
    SettingTrigger:= TRUE;
END_IF;

IF ((Done0=TRUE) OR (Error0=TRUE)) THEN
    SettingTrigger:= FALSE;
END_IF;

//Set IP address.
IF (SettingTrigger=TRUE) THEN
    NewIPAddress[0] := 16#C0;
    NewIPAddress[1] := 16#A8;
    NewIPAddress[2] := 16#FA;
    NewIPAddress[3] := 16#0A;
    NewSubnetMask[0] := 16#FF;
    NewSubnetMask[1] := 16#FF;
    NewSubnetMask[2] := 16#FF;
    NewSubnetMask[3] := 16#00;
    NewDefaultGateway[0] := 16#00;
    NewDefaultGateway[1] := 16#00;
    NewDefaultGateway[2] := 16#00;
    NewDefaultGateway[3] := 16#00;
END_IF;

//Change IP address.
ChangeIPAdr_instance(
    Execute := SettingTrigger,
    UnitNo := _CBU_CPU,
    BootPControl := UINT#0,
    IPAdr := NewIPAddress,
    SubnetMask := NewSubnetMask,
    DefaultGateway := NewDefaultGateway,
    Done =>Done0,
    Busy =>Busy0,
    Error =>Error0,
    ErrorID =>ErrorID0);
    
```

ChangeFTPAccount

The ChangeFTPAccount instruction changes the FTP login name and password of the built-in EtherNet/IP port on a CPU Unit or those of an EtherNet/IP Unit.

Instruction	Name	FB/ FUN	Graphic expression	ST expression
ChangeFTP Account	Change FTP Account	FB		ChangeFTPAccount_instance(Execute, UnitNo, NewUserName, NewPassword, Done, Busy, Error, ErrorID);

Variables

Name	Meaning	I/O	Description	Valid range	Unit	Default
UnitNo	Unit number	Input	Unit number for which to change the FTP login name and password	_CBU_CPU or _CBU_No00 to _CBU_No15*1	---	_CBU_No00
New UserName	Login name		Login name	1 to 12 single-byte alphanumeric characters (case sensitive)		---
New Password	Password		Password	*2		

*1 You can set *_CBU_No00* to *_CBU_No15* only for an NJ-series CPU Unit.

*2 The valid range depends on whether you specify the built-in EtherNet/IP port or an EtherNet/IP Unit for *UnitNo* (Unit number). Refer to Function, below, for details.

	Boolean	Bit strings					Integers							Real numbers	Times, durations, dates, and text strings						
	BOOL	BYTE	WORD	DWORD	LWORD	USINT	UINT	UDINT	ULINT	SINT	INT	DINT	LINT	REAL	LREAL	TIME	DATE	TOD	DT	STRING	
UnitNo																					
New UserName																					OK
New Password																					OK

Function

The ChangeFTPAccount instruction changes the FTP login name and password of the built-in EtherNet/IP port or EtherNet/IP Unit that is specified with *UnitNo* (Unit number), to the values specified with FTP login name *NewUserName* and password *NewPassword*.

When *Execute* changes from FALSE to TRUE, the values of *NewUserName* and *NewPassword* are written as the FTP login name and password of the built-in EtherNet/IP port. The value of *Busy* remains TRUE during execution of the instruction, and the value of *Done* changes to TRUE when reception of the setting change request is completed. The settings are not applied yet when *Done* changes to TRUE.

If you specify an EtherNet/IP Unit with *UnitNo*, the EtherNet/IP Unit is restarted when execution of the instruction ends. The new login name and password are enabled when restarting the Unit ends.

You can use this instruction to change the FTP login name and password of the built-in EtherNet/IP port or an EtherNet/IP Unit from an HMI.

The data type of *UnitNo* is enumerated type *_eUnitNo*. The meanings of the enumerators are as follows:

Enumerator	Meaning
<i>_CBU_CPU</i>	Built-in EtherNet/IP port
<i>_CBU_No00</i> to <i>_CBU_No15</i> *1	Unit number 00 to 15 of the EtherNet/IP Unit

*1 This can be set only for an NJ-series CPU Unit.

The valid range of the value of *NewPassword* depends on whether you specify the built-in EtherNet/IP port or an EtherNet/IP Unit for *UnitNo* (Unit number), as given below.

Setting of <i>UnitNo</i>	Valid range
Built-in EtherNet/IP port	8 to 32 single-byte alphanumeric characters (case sensitive)
EtherNet/IP Unit	1 to 8 single-byte alphanumeric characters (case sensitive)

The following example shows how to change the FTP login name and password of the EtherNet/IP Unit with unit number 00. If A (*Execute*) is changed to TRUE from an HMI or other device, the FTP login name is changed to 'OMRON' and the password is changed to 'omron0123'.

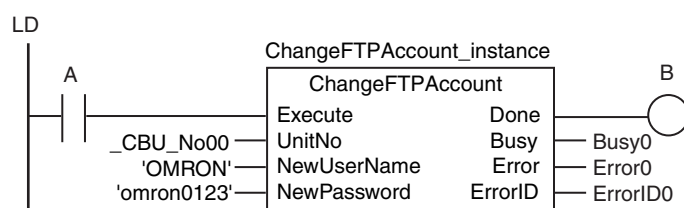

ST

```
ChangeFTPAccount_instance(A,_CBU_No00,'OMRON','omron0123',B,Busy0,Error0,ErrorID0);
```

The FTP login name is changed to 'OMRON' and the password is changed to 'omron0123' for the EtherNet/IP Unit with unit number 00.

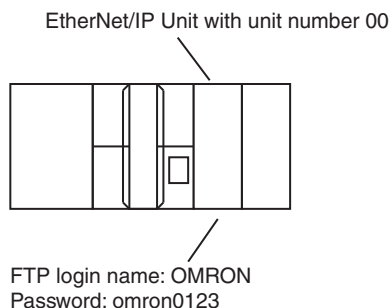

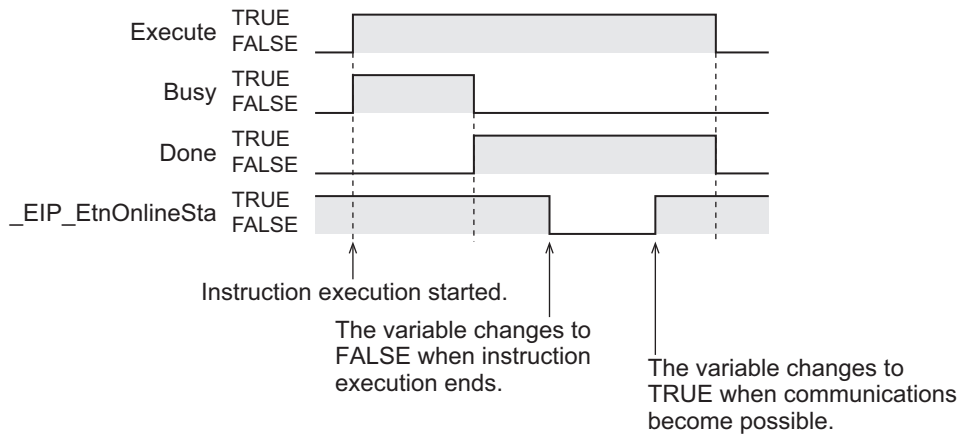

Related System-defined Variables

Name	Meaning	Data type	Description
_EIP_EtnOnlineSta ^{*1}	Online	BOOL	This variable indicates when built-in EtherNet/IP port communications can be used. TRUE: Communications are possible. FALSE: Communications are not possible.
_EIP1_EtnOnlineSta ^{*2}			
_EIP2_EtnOnlineSta ^{*3}			
_EIPIn1_EtnOnlineSta ^{*4}			

*1 Use this variable name for an NJ-series CPU Unit.

*2 Use this variable name for port 1 on an NX-series CPU Unit, or for an NY-series Controller.

*3 Use this variable name for port 2 on an NX-series CPU Unit.

*4 Use this variable name for the internal port on an NY-series Controller.

Additional Information

- You can change the FTP login name and password with this instruction even if the CPU Unit is write protected.
- Even if you change the FTP login name and password with this instruction during a file transfer, the file transfer will continue.

Precautions for Correct Use

- Execution of this instruction is continued until processing is completed even if the value of *Execute* changes to FALSE or the execution time exceeds the task period. The value of *Done* changes to TRUE when processing is completed. Use this to confirm normal completion of processing.
- Refer to *Using this Section* on page 2-3 for a timing chart for *Execute*, *Done*, *Busy*, and *Error*.
- You cannot use this instruction in an event task. A compiling error will occur.
- Error* is TRUE if an error occurred. The meanings of the values of *ErrorID* are given in the following table.

Value of <i>ErrorID</i>	Error name	Description
16#0400	Input Value Out of Range	<ul style="list-style-type: none"> The value of an input variable is outside of the valid range. The value of an input variable is incorrect.
16#2400	No Execution Right	<p>The instruction was executed when changing the status was not possible.</p> <ul style="list-style-type: none"> While changing the settings was already in progress While restarting the built-in EtherNet/IP port was in progress While downloading tag data link settings from the Network Configurator is in progress
16#2402	Too Many Simultaneous Instruction Executions	Too many ChangeIPAdr, ChangeFTPAccount, and ChangeNT-PServerAdr instructions were executed at the same time.



Version Information

A CPU Unit with unit version 1.02 or later and Sysmac Studio version 1.03 or higher are required to use this instruction.

ChangeNTPServerAdr

The ChangeNTPServerAdr instruction changes the address of the NTP server of the built-in EtherNet/IP port on a CPU Unit or the address of an EtherNet/IP Unit.

Instruction	Name	FB/ FUN	Graphic expression	ST expression
ChangeNTPServerAdr	Change NTP Server Address	FB		ChangeNTPServerAdr_instance(Execute, UnitNo, AdrType, IPAdr, HostName, Done, Busy, Error, ErrorID);

Variables

Name	Meaning	I/O	Description	Valid range	Unit	Default
UnitNo	Unit number	Input	Unit number for which to change the NTP server address	_CBU_CPU or _CBU_No00 to _CBU_No15*1	---	_CBU_No00
AdrType	Server setting method		NTP Server Address Setting Method TRUE: Host name FALSE: IP address	Depends on data type.		FALSE
IPAdr[] (array)*2	IP address		IP address of the NTP server	*3		---
HostName	Host name		Host name of the address of the NTP server	1 to 200 single-byte alphanumeric characters, "-" (hyphen), and "." (dot)*4		

*1 You can set *_CBU_No00* to *_CBU_No15* only for an NJ-series CPU Unit.

*2 This is a 4-element array with element numbers 0 to 3.

*3 The valid range depends on whether you specify the built-in EtherNet/IP port or an EtherNet/IP Unit for *UnitNo* (Unit number). Refer to *Function*, below, for details.

*4 There can be between 1 and 63 single-byte alphanumeric characters between any two dots. The valid range of *HostName* is valid only when server setting method *AdrType* is FALSE.

	Boolean	Bit strings				Integers						Real numbers	Times, durations, dates, and text strings							
	BOOL	BYTE	WORD	DWORD	LWORD	USINT	UINT	UDINT	ULINT	SINT	INT	DINT	LINT	REAL	LREAL	TIME	DATE	TOD	DT	STRING
UnitNo																				
AdrType	OK																			

	Boolean	Bit strings				Integers							Real numbers		Times, durations, dates, and text strings					
	BOOL	BYTE	WORD	DWORD	LWORD	USINT	UINT	UDINT	ULINT	SINT	INT	DINT	LINT	REAL	LREAL	TIME	DATE	TOD	DT	STRING
IPAdr[] (array)		OK																		
	Specify an array.																			
HostName																				OK

Function

The ChangeNTPServerAdr instruction changes the address of the NTP server of the built-in EtherNet/IP port or EtherNet/IP Unit that is specified with unit number *UnitNo*.

If server setting method *AdrType* is TRUE, the NTP server address is changed to IP address *IPAdr[]*. If server setting method *AdrType* is FALSE, the NTP server address is changed to host name *HostName*. When *Execute* changes from FALSE to TRUE, the values of *IPAdr[]* or *HostName* are written as the NTP server address. The value of *Busy* remains TRUE during execution of the instruction, and the value of *Done* changes to TRUE when reception of the setting change request is completed. The settings are not applied yet when *Done* changes to TRUE.

If you specify an EtherNet/IP Unit with *UnitNo*, the EtherNet/IP Unit is restarted when execution of the instruction ends. The new NTP server address is enabled when restarting the Unit ends.

You can use this instruction to change the NTP server address of the built-in EtherNet/IP port or an EtherNet/IP Unit from an HMI.

The data type of *UnitNo* is enumerated type *_eUnitNo*. The meanings of the enumerators are as follows:

Enumerator	Meaning
_CBU_CPU	Built-in EtherNet/IP port
_CBU_No00 to _CBU_No15*1	Unit number 00 to 15 of the EtherNet/IP Unit

*1 This can be set only for an NJ-series CPU Unit.

Set the IP address in order in elements 0 to 3 of *IPAdr[]*. For example, to change the NTP server address to IP address 130.58.17.32, set *IPAdr[0]* to BYTE#16#82, *IPAdr[1]* to BYTE#16#3A, *IPAdr[2]* to BYTE#16#11 and *IPAdr[3]* to BYTE#16#20.

The valid range of the value of *IPAdr[]* depends on whether you specify the built-in EtherNet/IP port or an EtherNet/IP Unit for unit number *UnitNo*, as given below. The valid ranges of the values are valid only when *AdrType* is TRUE.

Setting of <i>UnitNo</i>	Valid range
Built-in EtherNet/IP port	The following IP addresses cannot be used. All other IP addresses are valid. <ul style="list-style-type: none"> IP addresses that start with 127, 0, or 255 Class D IP addresses (224.0.0.0 to 239.255.255.255) Class E IP addresses (240.0.0.0 to 255.255.255.255) IP addresses that are reserved for AutoIP* (169.254.0.0 to 169.254.255.255) IP addresses of USB ports (192.168.255.0 to 192.168.255.255)
EtherNet/IP Unit	The following IP addresses cannot be used. All other IP addresses are valid. <ul style="list-style-type: none"> IP addresses that start with 127 Class D IP addresses (224.0.0.0 to 239.255.255.255) Class E IP addresses (240.0.0.0 to 255.255.255.255)

* AutoIP is an automatic IP address assignment feature of Windows 98 and later operating systems.

The following example shows how to change the NTP server address of the EtherNet/IP Unit with unit number 00. If A (*Execute*) is changed to TRUE from an HMI or other device, the NTP server address is changed. For example, assume that *IPAdr0[0]* is BYTE#16#C0, *IPAdr0[1]* is BYTE#16#A8, *IPAdr0[2]* is BYTE#16#FA, and *IPAdr0[3]* is BYTE#16#0A. If *Type (AdrType)* is TRUE, the NTP server address is changed to IP address 192.168.250.10. If *Type (AdrType)* is FALSE, the NTP server address is changed to host name ServerA.

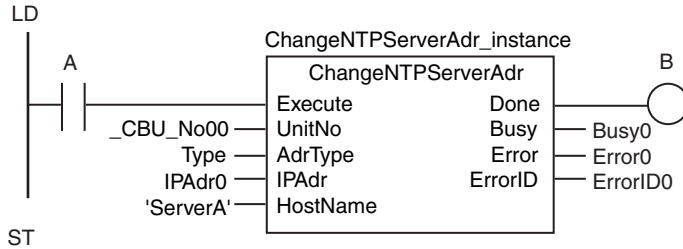

```
ChangeNTPServerAdr_instance(A,_CBU_No00,Type,IPAdr0,'ServerA',B,Busy0,Error0,ErrorID0);
```

The NTP server address of the EtherNet/IP Unit with a unit number of 00 is changed to an IP address of 192.168.250.10.

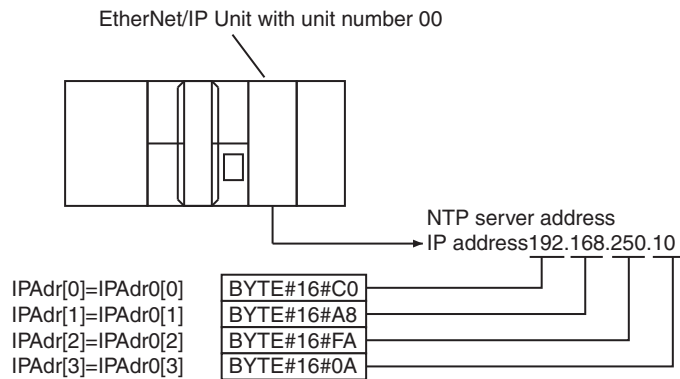

You can use the *_EIP_EtnOnlineSta*, *_EIP1_EtnOnlineSta*, or *_EIP2_EtnOnlineSta* system-defined variable to see if the port is in link ON status.

Here, *_EIP_EtnOnlineSta* is used as an example, but this information also applies to *_EIP1_EtnOnlineSta* and *_EIP2_EtnOnlineSta*.

When *Busy* changes to FALSE, the port changes to link OFF status and *_EIP_EtnOnlineSta* changes to FALSE. When the port then changes to link ON status, *_EIP_EtnOnlineSta* changes to TRUE.

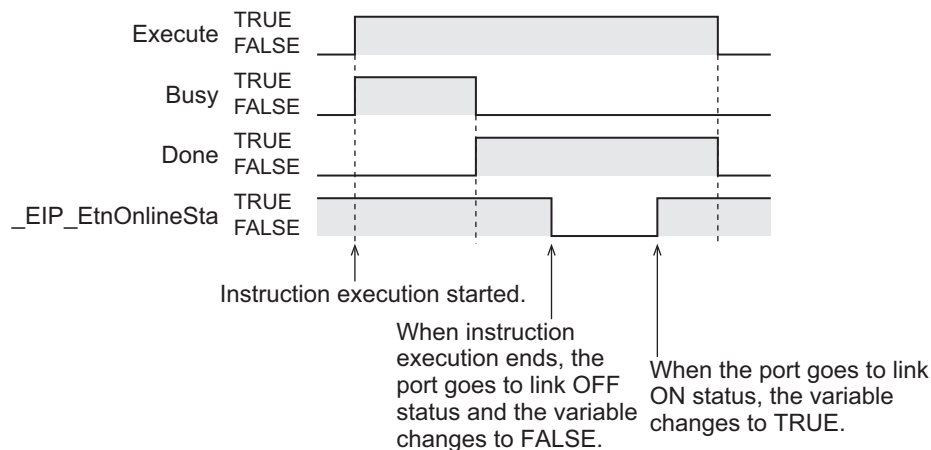

Related System-defined Variables

Name	Meaning	Data type	Description
_EIP_EtnOnlineSta*1	Online	BOOL	This variable indicates when built-in EtherNet/IP port communications can be used. TRUE: Communications are possible. FALSE: Communications are not possible.
_EIP1_EtnOnlineSta*2			
_EIP2_EtnOnlineSta*3			

*1 Use this variable name for an NJ-series CPU Unit.

*2 Use this variable name for port 1 on an NX-series CPU Unit.

*3 Use this variable name for port 2 on an NX-series CPU Unit.

Additional Information

- You can change the NTP server address with this instruction even if the CPU Unit is write protected.
- If the NTP server whose address is to change is set to operate at a specified time interval, measuring the specified time interval will start when execution of this instruction ends.

Precautions for Correct Use

- Execution of this instruction is continued until processing is completed even if the value of *Execute* changes to *FALSE* or the execution time exceeds the task period. The value of *Done* changes to *TRUE* when processing is completed. Use this to confirm normal completion of processing.
- Refer to *Using this Section* on page 2-3 for a timing chart for *Execute*, *Done*, *Busy*, and *Error*.
- You cannot use this instruction in an event task. A compiling error will occur.
- Error* is *TRUE* if an error occurred. The meanings of the values of *ErrorID* are given in the following table.

Value of <i>ErrorID</i>	Error name	Description
16#0400	Input Value Out of Range	The value of <i>IPAdr[]</i> or <i>HostName</i> is not correct*1
16#2400	No Execution Right	The instruction was executed when changing the status was not possible. <ul style="list-style-type: none"> While changing the settings was already in progress While restarting the built-in EtherNet/IP port was in progress While downloading tag data link settings from the Network Configurator is in progress
16#2402	Too Many Simultaneous Instruction Executions	Too many <i>ChangeIPAdr</i> , <i>ChangeFTPAccount</i> , and <i>ChangeNTPServerAdr</i> instructions were executed at the same time.

*1 The setting range is checked only for the specified *AdrType*.



Version Information

A CPU Unit with unit version 1.02 or later and Sysmac Studio version 1.03 or higher are required to use this instruction.

FTPGetFileList

The FTPGetFileList instruction gets a list of the files in the FTP server.

Instruction	Name	FB/FUN	Graphic expression	ST expression
FTPGetFileList	Get FTP Server File List	FB		<pre>FTPGetFileList_instance(Execute, ConnectSvr, SvrDirName, GetFileNum, SortOrder, ExecOption, RetryCfg, Cancel, FileList, Done, Busy, CommandCanceled, Error, ErrorID, ErrorIDEx, StoredNum);</pre>

Variables

Name	Meaning	I/O	Description	Valid range	Unit	Default
Connect Svr	Connected FTP server settings	Input	Setting parameters for the connected FTP server	---	---	*1
SvrDir Name	FTP server directory name		Name of FTP server directory for which to get the file list	256 bytes max. (255 single-byte alphanumeric characters plus the final NULL character)*2		**3
GetFile Num	Number of files to list		Number of files to list	1 to 1000		1
SortOrder*4	Sort order		Order to sort the file list	_NAME_ASC, _NAME_DESC, _DATE_ASC, _DATE_DESC		_NAME_ASC
Exec Option	FTP execution options		Options for FTP execution	---		---
RetryCfg	Execution retry settings		Instruction execution retry settings	---		---
Cancel	Cancel		TRUE: Instruction execution is canceled. FALSE: Instruction execution is not canceled.	Depends on data type.		FALSE

Name	Meaning	I/O	Description	Valid range	Unit	Default
FileList[] array*5*6*7	File details	In-out	Details for the obtained file list	---	---	*1
Command-Canceled	Cancel completed	Output	TRUE: Canceling completed. FALSE: Canceling not completed.	Depends on data type.	---	---
StoredNum	Number of files obtained in list		Number of files for which details were obtained	0 to 1000		

- *1 If you omit an input parameter, the default value is not applied. A building error will occur.
- *2 You cannot use the following characters in FTP server directory names: * ? < > | "
- *3 The default is the home directory when you log onto the FTP server.
- *4 If the FTP server does not support sorting names, the names are in ascending order regardless of the value of *SortOrder*.
- *5 The array can have a maximum of 1,000 elements.
- *6 This is a one-dimensional array. If an array with more than one dimension is specified, a building error will occur.
- *7 The first array element number is 0. If a number other than 0 is specified for the first array element, a building error will occur.

	Boolean	Bit strings				Integers								Real numbers		Times, durations, dates, and text strings					
	BOOL	BYTE	WORD	DWORD	LWORD	USINT	UINT	UDINT	ULINT	SINT	INT	DINT	LINT	REAL	LREAL	TIME	DATE	TOD	DT	STRING	
ConnectSvr	Refer to <i>Function</i> for details on the structure <code>_sFTP_CONNECT_SVR</code> .																				
SvrDirName																					OK
GetFileNum							OK														
SortOrder	Refer to <i>Function</i> for the enumerators of the enumerated type <code>_eFILE_SORT_ORDER</code> .																				
ExecOption	Refer to <i>Function</i> for details on the structure <code>_sFTP_EXEC_OPTION</code> .																				
RetryCfg	Refer to <i>Function</i> for details on the structure <code>_sFTP_RETRY_CFG</code> .																				
Cancel	OK																				
FileList[] array	Refer to <i>Function</i> for details on the structure <code>_sFTP_FILE_DETAIL</code> .																				
Command Canceled	OK																				
StoredNum							OK														

Function

The FTPGetFileList instruction gets a list of files and file details from the specified directory *SvrDirName* on the connected FTP server *ConnectSvr*.

Specify the number of files to list in *GetFileNum*. Specify the order in which to sort the obtained file information in *SortOrder*.

The data type of *ConnectSvr* is structure `_sFTP_CONNECT_SVR`. The specifications are as follows:

Name	Meaning	Description	Data type	Valid range	Unit	Default
ConnectSvr	Connected FTP server settings	Setting parameters for the connected FTP server	<code>_sFTP_CONNECT_SVR</code>	---	---	---
Adr	Address	IP address or host name*1	STRING	1 to 200 bytes*2	---	---
PortNo	Port number	TCP port number of FTP server control connection	UINT	0 to 65535*3		
UserName	User name	User name on FTP server	STRING	33 bytes max.*4*5*6		
Password	Password	FTP server password	STRING	33 bytes max.*4*5*6		

*1 A separate DNS or Hosts setting is required to specify a host name.

*2 You can use the following single-byte characters: A to Z, a to z, 0 to 9, - (hyphen), . (period), and _ (underbar).

*3 If you specify 0, TCP port number 21 is used.

*4 You can use the following single-byte characters: A to Z, a to z, 0 to 9, - (hyphen), . (period), and _ (underbar). You can also use \ and @ for a CPU Unit with unit version 1.16 or later.

*5 The NULL character at the end must be counted in the number of bytes.

*6 For CPU Units with unit version 1.08, specify a text string of one character or more. An error will occur if you specify a text string that contains only the final NULL character.

The data type of *SortOrder* is enumerated type `_eFILE_SORT_ORDER`. The meanings of the enumerators are as follows:

Enumerator	Meaning
<code>_NAME_ASC</code>	Ascending order of names
<code>_NAME_DESC</code>	Descending order of names
<code>_DATE_ASC</code>	Ascending order of last modified dates
<code>_DATE_DESC</code>	Descending order of last modified dates

The file details is stored in *FileList[]*. The number of files for which information was obtained is stored in *StoredNum*.

The data type of *FileList[]* is structure `_SFTP_FILE_DETAIL`. The specifications are as follows:

Name	Meaning	Description	Data type	Valid range	Unit	Default
FileList	File details	Details for the obtained file list	<code>_SFTP_FILE_DETAIL</code>	---	---	---
Name	File or folder name	File or folder name	STRING	256 bytes max. (255 single-byte alphanumeric characters plus the final NULL character)	---	---
ModifiedDate	Last modified date	The last modified data of the file or folder	DATE_AND_TIME	---		
Size	File size	The file size*1	ULINT		Bytes	
ReadOnly	Read-only attribute	The read-only attribute of the file or folder TRUE: Read only FALSE: Not read only	BOOL	Depends on data type.	---	
Folder	Folder	TRUE: Folder FALSE: Not a folder	BOOL			

*1 The file size is 0 for a folder.

Specifying Options for FTP Server Processing

The operation specified with *ExecOption* is performed to obtain the file list from the FTP server.

The option settings are the same as those for the `FTPGetFile` instruction (page 2-1152). Refer to the specified page for details.

However, the only option that is valid for this instruction is *ExecOption.PassiveMode*.

Specifying Retrying Connection Processing with the FTP Server

Connection processing with the FTP server times out and ends when the specified timeout time *RetryCfg.TimeOut* is exceeded before a connection is successfully established. If the FTP server rejects the connection, processing ends before reaching the timeout time. After failing to connect, connection processing is retried after the specified retry interval *RetryCfg.RetryInterval*. If a connection with the FTP server is not established within the number of retries specified with *RetryCfg.RetryNum*, an instruction execution error occurs.

If, after a successful connection to the FTP server, a problem occurs on the network that interrupts file transfer for longer than the time specified with *RetryCfg.TimeOut*, a timeout occurs and retry processing is not performed.

The data type of *RetryCfg* is structure `_sFTP_RETRY_CFG`. The specifications are as follows:

Name	Meaning	Description	Data type	Valid range	Unit	Default
RetryCfg	Execution retry settings	Instruction execution retry settings	<code>_sFTP_RETRY_CFG</code>	---	---	---
TimeOut	Timeout time	Timeout time for a connection to the FTP server	UINT	0 to 60* ¹	Seconds	20
RetryNum	Number of retries	The number of retries when connection fails	UINT	0 to 3	Times	0
RetryInterval	Retry interval	The interval for retrying when connection fails	UINT	0 to 65535* ²	Seconds	1

*1 If 0 is set, the timeout time is 20 s.

*2 If 0 is set, the retry interval is 1 s.

The following figure shows the relation between the timeout time, number of retries, and retry interval when an FTP client performs connection processing to a FTP server.

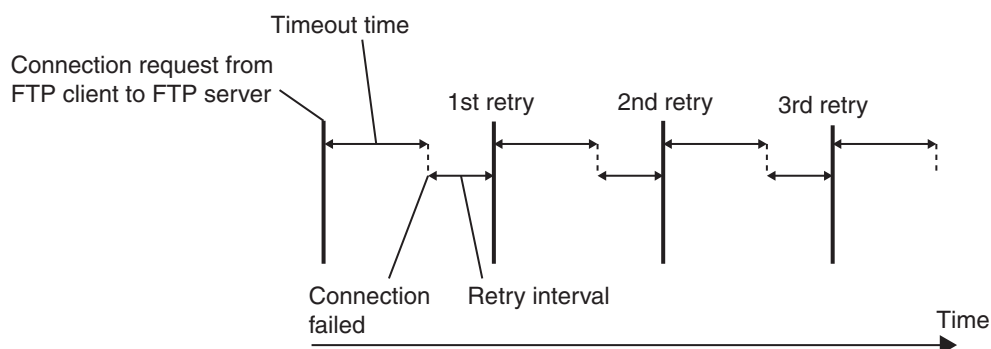

● **Successfully Connecting to the FTP Server**

When connection processing to the FTP server is successfully completed and the file list is obtained from the FTP server, the following processing is performed.

- A value of 16#0000 is stored in *ErrorID*.
- The obtained data is stored in the output data, such as *FileList[]*.
- The value of *Done* is changed to TRUE.

The following timing chart is an example for successful connection processing to the FTP server.

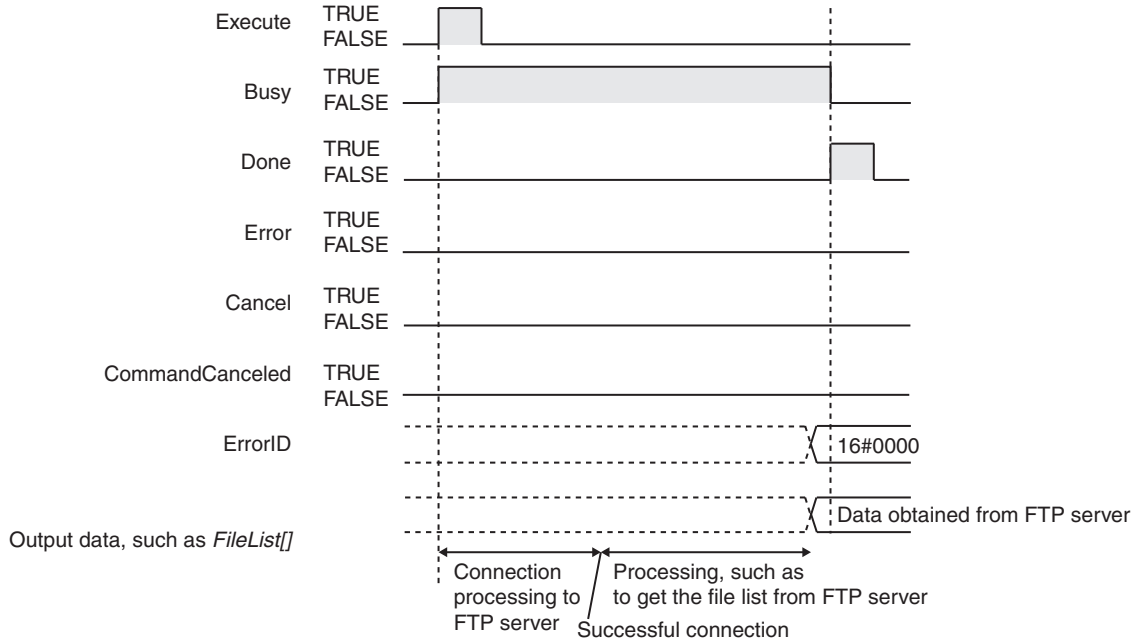

● **Failing to Connect to the FTP Server**

The following processing is performed when connection processing to the FTP server fails.

- The error code is stored in *ErrorID*.
- The value of *Error* is changed to TRUE.

The following timing chart is an example for when connection processing to the FTP server fails.

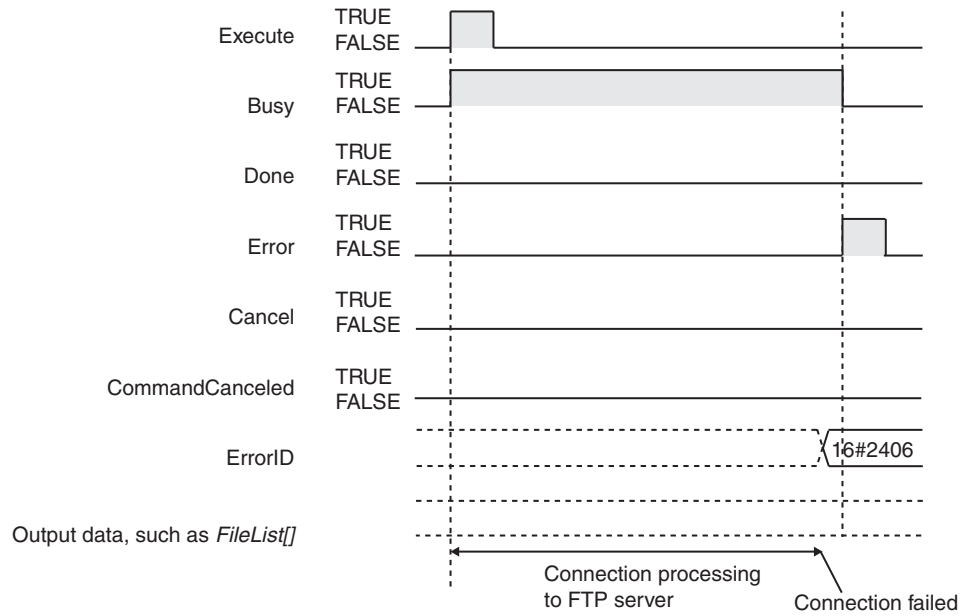

Canceling Instruction Execution

If *Cancel* changes to TRUE during instruction execution, processing with the FTP server is forced to end. You can use it to end processing when obtaining the file list or connection processing to the FTP server is taking too much time.

● When *Cancel* Changes to TRUE during Processing with the FTP Server

The following occurs if *Cancel* changes to TRUE while the FTPGetFileList instruction is obtaining a file list from the FTP server.

Any file details that were obtained from the FTP server is stored in *FileList[]*.

The number of files for which file details were correctly obtained is stored in *StoredNum*.

The value of *Done* does not change to TRUE.

The value of *CommandCanceled* changes to TRUE when cancellation is completed. Use this to confirm normal completion of cancellation.

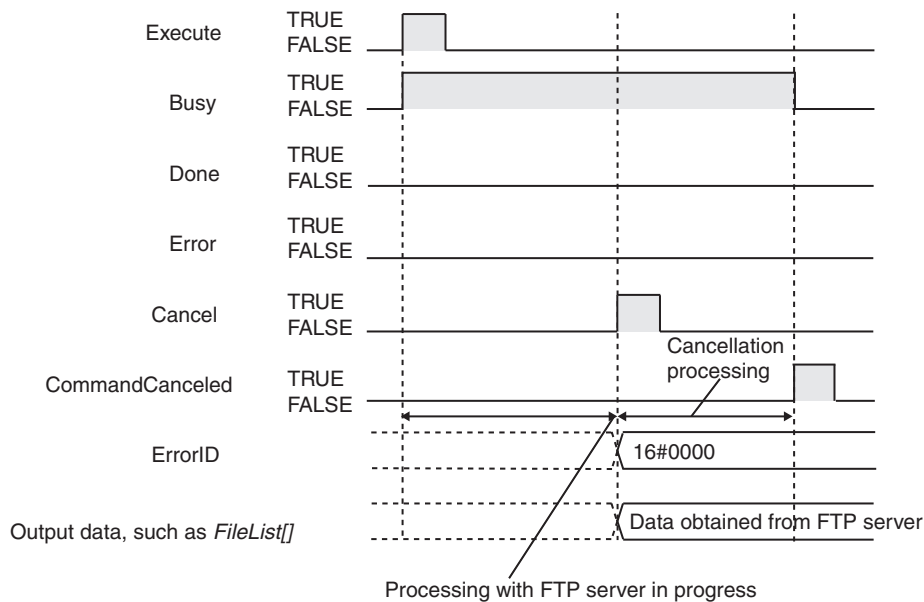

● **When Processing with the FTP Server Is Completed Before Cancellation Processing Is Started**

Even if *Cancel* is changed to TRUE, *Done* changes to TRUE to indicate normal completion if processing with the FTP server is completed before cancellation processing is started. The value of *CommandCanceled* does not change to TRUE.

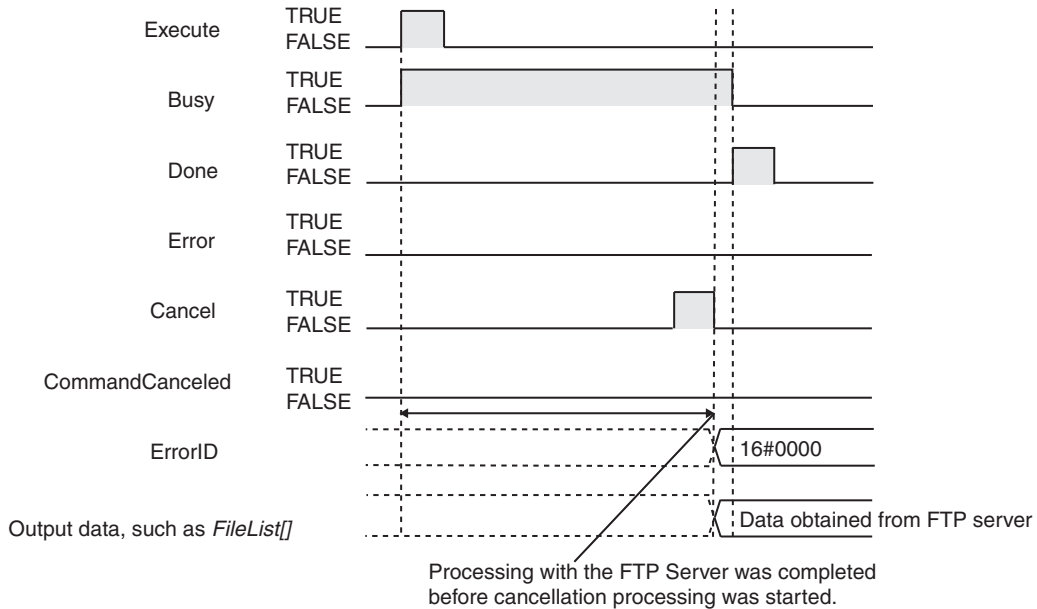

● **When both *Cancel* and *Execute* Are TRUE**

If both *Cancel* and *Execute* are TRUE, cancellation is given priority and processing is not performed with the FTP server. *CommandCanceled* changes to TRUE.

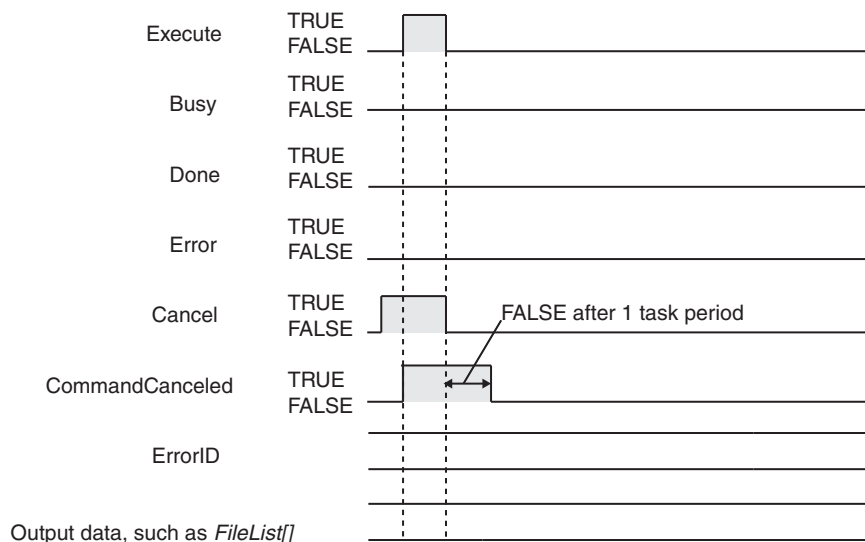

Related System-defined Variables

Name	Meaning	Data type	Description
_EIP_EtnOnlineSta*1	Online	BOOL	This variable indicates when built-in EtherNet/IP port communications can be used. TRUE: Communications are possible. FALSE: Communications are not possible.
_EIP1_EtnOnlineSta*2			
_EIP2_EtnOnlineSta*3			
_EIPIn1_EtnOnlineSta*4			

*1 Use this variable name for an NJ-series CPU Unit.

*2 Use this variable name for port 1 on an NX-series CPU Unit, or for an NY-series Controller.

*3 Use this variable name for port 2 on an NX-series CPU Unit.

*4 Use this variable name for the internal port on an NY-series Controller.

Precautions for Correct Use

- This instruction can be used only for the built-in EtherNet/IP ports on NJ/NX-series CPU Units and NY-series Controllers.
- Execution of this instruction is continued until processing is completed even if the value of *Execute* changes to FALSE or the execution time exceeds the task period. The value of *Done* changes to TRUE when processing is completed. Use this to confirm normal completion of processing.
- Refer to *Using this Section* (page 2-3) for a timing chart for *Execute*, *Done*, *Busy*, and *Error*.
- If there are no files or subdirectories in the directory specified by the *SvrDirName* input variable, *Done* changes to TRUE to indicate a normal end. If 0 is stored in *StoredNum*, nothing is stored in *FileList[]*.
- If the number of array elements in *FileList[]* is less than the number of files specified with the *GetFileNum* input variable, only the file information that will fit in *FileList[]* is stored and the file information that does not fit is not stored. In this case, *Error* does not change to TRUE.
- If a file name exceeds 255 characters, the first 255 characters are stored in *Name* in *FileList[]*. In this case, *Error* does not change to TRUE.
- It may be impossible to obtain some or all of the specified file details depending on FTP server specifications. The members of *FileList[]* take the following values for files for which details are not obtained. In this case, the value of *Error* is FALSE.

Member	Value
ModifiedDate	DT#1970-01-01-00:00:00.000000000
Size	0
ReadOnly	FALSE
Folder	FALSE

- You can execute a maximum of 3 of the following instructions at the same time: FTPGetFileList, FTPGetFile, FTPPutFile, FTPRemoveFile, and FTPRemoveDir.
- An error will occur in the following cases. *Error* will change to TRUE.
 - The value of any input parameter is outside of the valid range.
 - “..” is specified for a directory level in *SvrDirName*.
 - An incorrect path such as “//” is specified for *SvrDirName*.
 - The directory specified by *SvrDirName* does not exist on the FTP server.
 - The FTP server specified by *ConnectSvr* does not exist on the network or the specified FTP server is not operating.
 - More than 3 of the following instructions were executed at the same time: FTPGetFileList, FTPGetFile, FTPPutFile, FTPRemoveFile, and FTPRemoveDir.

- File transfer processing was interrupted during FTP server connection processing by a problem on the network.
- For this instruction, expansion error code *ErrorIDEx* gives the FTP response code that was returned by the FTP server. The following table lists typical values of *ErrorIDEx* and describes the meanings of the errors and the corrections. For details, refer to FTP server specifications. An expansion error code is output to *ErrorIDEx* when the value of error code *ErrorID* is WORD#16#2407.

Value of <i>ErrorIDEx</i>	Meaning	Correction
16#000001A9	It was not possible to establish a data connection.	If you use FTP communications with an FTP server over the Internet, make sure that the FTP open mode is not set to active.
16#000001AA	The connection was closed. Data transfer was aborted.	Check the connection to the FTP server. Make sure that the FTP server is operating.
16#000001C2	It was not possible to perform the requested file operation. Using the file was not possible, e.g., it is already open.	Make sure that the file is not open for any other application.
16#00000212	User login was not possible.	Check the FTP user name and password.
16#00000214	An account to save files is required.	Check the FTP user access rights.
16#00000226	Execution of the requested file operation was not possible because using the file was not possible, e.g., accessing it was not possible because it was not found.	Make sure that a file with the specified name exists in the directory on the FTP server. Check the access rights of the specified file.
16#00000229	Execution was not possible because the file name was not correct.	Check the access rights of the specified directory.



Version Information

A CPU Unit with unit version 1.08 or later and Sysmac Studio version 1.09 or higher are required to use this instruction.

Sample Programming

The following programming downloads a file from the /Recipe directory on the FTP server and stores it in the root directory of an SD Memory Card.

The file to download is the last file in the /Recipe directory on the FTP server when the files are sorted in ascending order of names.

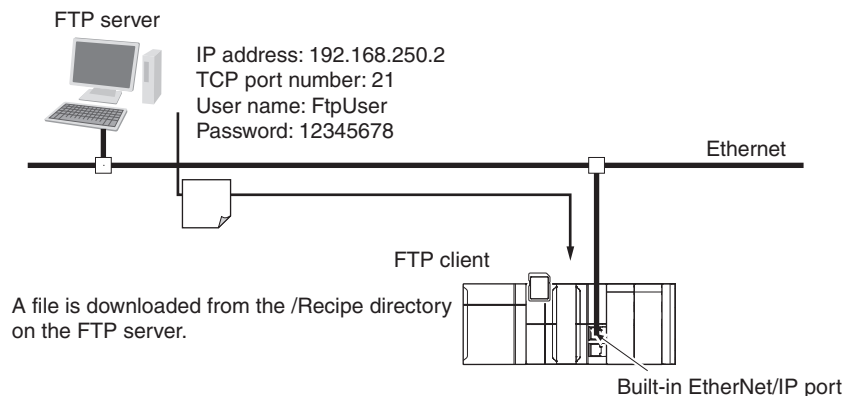

The Controller is connected to the FTP server through an EtherNet/IP network. The settings of the parameters to connect to the FTP server are given in the following table.

Parameter	Value
IP address	192.168.250.2
TCP port number	21
User name	FtpUser
Password	12345678

The following procedure is used.

- 1 The FTPGetFileList instruction is used to get a file list from the FTP server. The following table gives the FTP server directory name, number of files to list, sort order, and variable to store file details.

Item	Specification
FTP server directory name	'/Recipe'
Number of files to list	1000
Sort order	Ascending order of names
Variable to store file details	FTPFileList[]

- 2 The FTPGetFile instruction is used to download the last file from the file list obtained in step 1 when the list is in ascending order of names. The file is stored in the root directory on the SD Memory Card.
- 3 Normal end processing is executed if all processing ends normally. Processing for an error end is performed if an error occurs.

LD

Internal Variables	Variable	Data type	Initial value	Comment
	FTPGetFileList_instance	FTPGetFileList		Instance of FTPGetFileList instruction
	FTPGetFile_instance	FTPGetFile		Instance of FTPGetFile instruction
	FTPAddr	_sFTP_CONNECT_SVR	(Adr := "", PortNo := 0, UserName := "", Password := "")	Connected FTP server settings
	FTPFileList	ARRAY[0..999] OF _sFTP_FILE_DETAIL	[1000((Name := "", ModifiedDate := DT#1970-01-01-00:00:00, Size := 0, ReadOnly := False, Folder := False))]	File details
	GetResult	ARRAY[0..0] OF _sFTP_FILE_RESULT	[(Name := "", TxError := False, RemoveError := False, Reserved := [4(16#0)])]	Downloaded file results
	FTPStoredNum	UINT	0	Number of files obtained in file list
	LastFileIndex	UINT	0	Index of last file when list is in ascending order of names
	RS_instance	RS		Instance of RS instruction
	OperatingEnd	BOOL	FALSE	Processing completed
	Trigger	BOOL	FALSE	Execution condition
	Operating	BOOL	FALSE	Processing

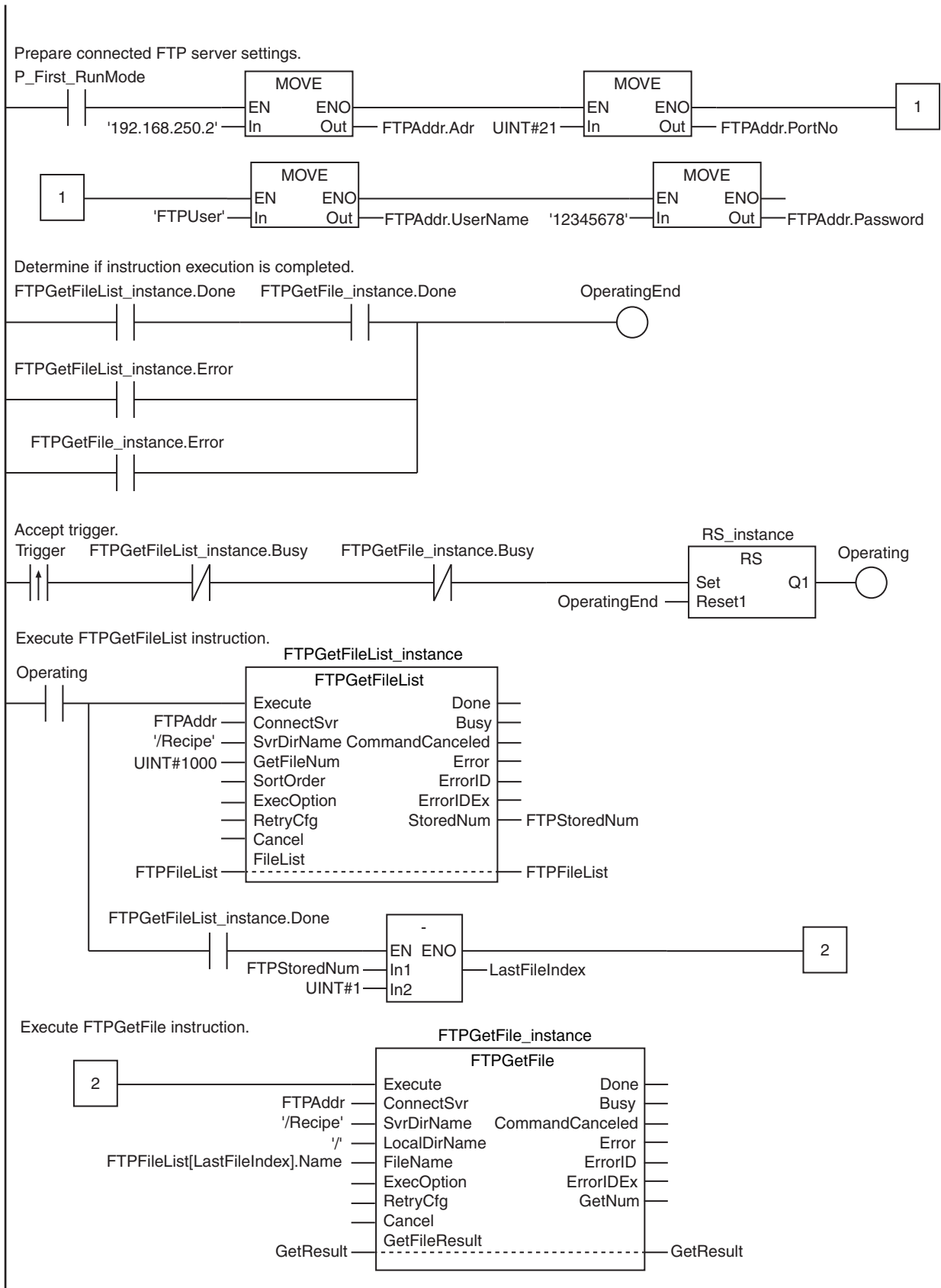

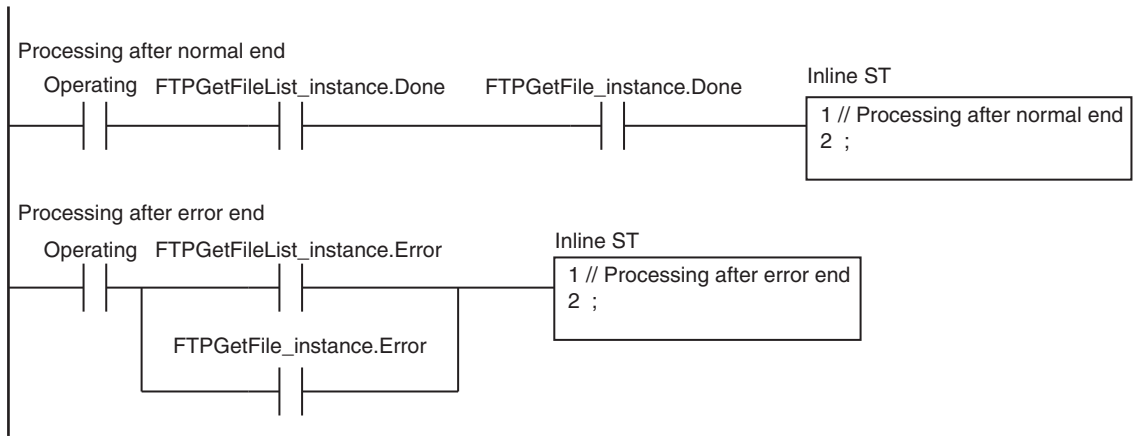

ST

Internal Variables	Variable	Data type	Initial value	Comment
	R_TRIG_instance	R_TRIG		Instance of R_TRIG instruction
	UP_Q	BOOL	FALSE	Trigger output
	FTPGetFile_instance	FTPGetFile		Instance of FTPGetFile instruction
	FTPGetFileList_instance	FTPGetFileList		Instance of FTPGetFileList instruction
	FTPFileList	ARRAY[0..999] OF _sFTP_FILE_DE-TAIL	[1000((Name := ", Modified-Date := DT#1970-01-01-00:00:00, Size := 0, ReadOnly := False, Folder := False))]	File details
	FTPStoredNum	UINT	0	Number of files obtained in file list
	DoFTPTrigger	BOOL	FALSE	Execution condition for FTPGetFileList and FTPGetFile
	FTPAddr	_sFTP_CONNECT_SVR	(Adr := ", PortNo := 0, UserName := ", Password := ")	Connected FTP server settings
	GetResult	ARRAY[0..0] OF _sFTP_FILE_RESULT	[(Name := ", TxError := False, RemoveError := False, Reserved := [4(16#0)])]	Downloaded file results
	Stage	UINT	0	Instruction execution stage
	Trigger	BOOL	FALSE	Execution condition

```
// Prepare connected FTP server settings.
IF P_First_RunMode THEN
  FTPAddr.Adr      := '192.168.250.2'; // Address
  FTPAddr.PortNo  := UINT#21;         // Port number
  FTPAddr.UserName := 'FtpUser';     // User name
  FTPAddr.Password := '12345678';    // Password
END_IF;

Accept trigger.
R_TRIG_instance(Trigger, UP_Q);
IF ( (UP_Q = TRUE) AND (FTPGetFileList_instance.Busy = FALSE) AND
    (FTPGetFile_instance.Busy = FALSE) ) THEN
  DoFTPTrigger := TRUE;
  Stage := INT#1;
  FTPGetFileList_instance( // Initialize instance.
    Execute      := FALSE,
    ConnectSvr   := FTPAddr,
    SvrDirName   := '/Recipe',
    GetFileNum   := UINT#1000,
    FileList     := FTPFileList,
    StoredNum    => FTPStoredNum);
  FTPGetFile_instance( // Initialize instance.
    Execute      := FALSE,
    ConnectSvr   := FTPAddr,
    SvrDirName   := '/Recipe',
    LocalDirName := '/',
    FileName     := '',
    GetFileResult := GetResult);
END_IF;
```

```

IF (DoFTPTrigger = TRUE) THEN
CASE Stage OF
  1 : // Execute FTPGetFileList instruction
    FTPGetFileList_instance(
      Execute      := TRUE,           // Execution
      ConnectSvr  := FTPAddr,       // Connected FTP server
      SvrDirName  := '/Recipe',     // FTP server directory name
      GetFileNum  := UINT#1000,     // Number of files to list
      FileList    := FTPFileList,   // File details
      StoredNum   => FTPStoredNum) ;// Number of files obtained in list
    IF (FTPGetFileList_instance.Done = TRUE) THEN
      Stage := INT#2;               // To next stage
    ELSIF (FTPGetFileList_instance.Error = TRUE) THEN
      Stage := INT#10;              // Error end
    END_IF;
  2 : // Execute FTPGetFile instruction.
    FTPGetFile_instance(
      Execute      := TRUE,
      // Execution
      ConnectSvr   := FTPAddr,
      // Connected FTP server
      SvrDirName   := '/Recipe',
      // FTP server directory name
      LocalDirName := '/',
      // Local directory name
      FileName     := FTPFileList[FTPStoredNum - 1].Name,
      // File name
      GetFileResult := GetResult) ;
      // Downloaded file results
    IF (FTPGetFile_instance.Done = TRUE) THEN
      Stage := INT#0;                // Normal end
    ELSIF (FTPGetFile_instance.Error = TRUE) THEN
      Stage := INT#20;               // Error end
    END_IF;
  0: // Processing after normal end
    DoFTPTrigger:=FALSE;
    Trigger      :=FALSE;
  ELSE // Processing after error end
    DoFTPTrigger:=FALSE;
    Trigger      :=FALSE;
  END_CASE;
END_IF;

```

FTPGetFile

The FTPGetFile instruction downloads a file from the FTP server.

Instruction	Name	FB/FUN	Graphic expression	ST expression
FTPGetFile	Get File from FTP Server	FB		<pre>FTPGetFile_instance(Execute, ConnectSvr, SvrDirName, LocalDirName, FileName, ExecOption, RetryCfg, Cancel, GetFileResult, Done, Busy, CommandCanceled, Error, ErrorID, ErrorIDEx, GetNum);</pre>

Variables

Name	Meaning	I/O	Description	Valid range	Unit	Default
Connect Svr	Connected FTP server settings	Input	Setting parameters for the connected FTP server	---	---	*1
SvrDir Name	FTP server directory name		Name of FTP server directory from which to download a file	256 bytes max. (255 single-byte alphanumeric characters plus the final NULL character)*2		"*3
LocalDir Name	Local directory name		Name of the directory in which to store the file downloaded from the FTP server	256 bytes max. (255 single-byte alphanumeric characters plus the final NULL character)		'/'
FileName	File name		Name of file to download*4	256 bytes max. (255 single-byte alphanumeric characters plus the final NULL character)*5		*1
Exec Option	FTP execution options		Options for FTP execution	---		---
RetryCfg	Execution retry settings		Instruction execution retry settings	---		---
Cancel	Cancel		TRUE: Instruction execution is canceled. FALSE: Instruction execution is not canceled.	Depends on data type.		FALSE

Name	Meaning	I/O	Description	Valid range	Unit	Default
GetFileResult[] array*6*7*8	Downloaded file results	In-out	Downloaded file results	---	---	*1
Command-Canceled	Cancel completed	Output	TRUE: Canceling completed. FALSE: Canceling not completed.	Depends on data type.	---	---
GetNum	Number of files to download		Number of files to download	---		

- *1 If you omit an input parameter, the default value is not applied. A building error will occur.
- *2 You cannot use the following characters in FTP server directory names: * ? < > | "
- *3 The default is the home directory when you log onto the FTP server.
- *4 You can use wildcards in file names.
- *5 You cannot use the following character in file names: |
- *6 The array can have a maximum of 1,000 elements.
- *7 This is a one-dimensional array. If an array with more than one dimension is specified, a building error will occur.
- *8 The first array element number is 0. If a number other than 0 is specified for the first array element, a building error will occur.

	Boolean	Bit strings					Integers						Real numbers	Times, durations, dates, and text strings						
	BOOL	BYTE	WORD	DWORD	LWORD	USINT	UINT	UDINT	ULINT	SINT	INT	DINT	LINT	REAL	LREAL	TIME	DATE	TOD	DT	STRING
ConnectSvr	Refer to <i>Function</i> for details on the structure <code>_sFTP_CONNECT_SVR</code> .																			
SvrDirName																				OK
LocalDirName																				OK
FileName																				OK
ExecOption	Refer to <i>Function</i> for details on the structure <code>_sFTP_EXEC_OPTION</code> .																			
RetryCfg	Refer to <i>Function</i> for details on the structure <code>_sFTP_RETRY_CFG</code> .																			
Cancel	OK																			
GetFileResult[] array	Refer to <i>Function</i> for details on the structure <code>_sFTP_FILE_RESULT</code> .																			
Command Canceled	OK																			
GetNum							OK													

Function

The FTPGetFile instruction downloads the file specified with *FileName* from the specified directory *SvrDirName* on the connected FTP server *ConnectSvr* to the directory specified with *LocalDirName* in the SD Memory Card. If the specified directory *LocalDirName* does not exist in the SD Memory Card, a new directory is created and the specified file is downloaded.

You can use wildcards in *FileName*. This allows you to download more than one file at one time.

The results of downloading is stored in *GetFileResult[]* for each file. Store the number of files to download in *GetNum*. If you use a wildcard in *FileName*, store the number of files with names that match the wildcard.

If the actual number of transferred files is different, the value of *GetFileResult[]*.TxError changes to TRUE.

If an error occurs when deleting the source file after the download, the value of *GetFileResult[]*.RemoveError changes to TRUE.

With an NY-series Controller, files are downloaded into the shared folder (Virtual SD Memory Card). Before downloading files to the Virtual SD Memory Card, you must make the settings for the Virtual SD Memory Card. Refer to the *NY-series Industrial Panel PC / Industrial Box PC Software User's Manual* (Cat. No. W558) for details on a Virtual SD Memory Card.

The data type of *ConnectSvr* is structure `_sFTP_CONNECT_SVR`. The specifications are as follows:

Name	Meaning	Description	Data type	Valid range	Unit	Default
ConnectSvr	Connected FTP server settings	Setting parameters for the connected FTP server	<code>_sFTP_CONNECT_SVR</code>	---	---	---
Adr	Address	IP address or host name*1	STRING	1 to 200 bytes*2	---	---
PortNo	Port number	TCP port number of FTP server control connection	UINT	0 to 65535*3		
UserName	User name	User name on FTP server	STRING	33 bytes max.*4*5*6		
Password	Password	FTP server password	STRING	33 bytes max.*4*5*6		

*1 A separate DNS or Hosts setting is required to specify a host name.

*2 You can use the following single-byte characters: A to Z, a to z, 0 to 9, - (hyphen), . (period), and _ (underbar).

*3 If you specify 0, TCP port number 21 is used.

*4 You can use the following single-byte characters: A to Z, a to z, 0 to 9, - (hyphen), . (period), and _ (underbar). You can also use \ and @ for a CPU Unit with unit version 1.16 or later.

*5 The NULL character at the end must be counted in the number of bytes.

*6 For CPU Units with unit version 1.08, specify a text string of one character or more. An error will occur if you specify a text string that contains only the final NULL character.

The data type of *GetFileResult[]* is structure `_sFTP_FILE_RESULT`. The specifications are as follows:

Name	Meaning	Description	Data type	Valid range	Unit	Default
GetFileResult	Downloaded file results	Transferred file results	<code>_sFTP_FILE_RESULT</code>	---	---	---
Name	File name*1	Transferred file name	STRING	256 bytes max. (255 single-byte alphanumeric characters plus the final NULL character)	---	---
TxError	Transfer error	TRUE: Transfer ended in an error. FALSE: Transfer ended normally.	BOOL	Depends on data type.		
RemoveError	Deletion error	TRUE: Deletion ended in an error. FALSE: Deletion ended normally.	BOOL			
Reserved	Reserved	Reserved by the system.	ARRAY[0..3] Of Byte	---		

*1 The file name extension is included.

Using Wildcards to Specify File Names

You can use wildcards to specify the names of the files to download in *FileName*.

As wildcards, you can specify “*” and “?”. “*” represents one or more characters. “?” represents only one character.

Examples of using wildcard specifications are given below.

Assume that the FTP server directory has the following file structure.

```

|—DataFiles (specified directory)
| | LogA01.log
| | LogA02.txt
| | LogB.log
| | LogC.txt
| | ControlDataA1.csv
| | ControlDataA10.csv
| | ControlDataA100.csv
| | ControlDataB10.csv
| | ControlDataC100.csv
|—ControlSubDataFiles (subdirectory)
|   SubData_A001.txt
|   SubData_A002.txt

```

As shown in the following table, the way that the wildcards are used determines the files that are specified.

Wildcard specification	Specified files
Log*.log	LogA01.log, LogB.log
Log?.log	LogB.log
Log?.*	LogB.log, LogC.txt
Data	ControlDataA1.csv, ControlDataA10.csv, ControlDataA100.csv, ControlDataB10.csv, ControlDataC100.csv, (ControlSubDataFiles)* ¹
*	All files except for those in the subdirectory
.	All files except for those in the subdirectory
??	No files
???????	LogB.log, LogC.txt

*1 Subdirectory files will also be included for some FTP server specifications.

If you specify wildcards, you can download up to 1,000 files.

If *GetFileResult[].TxError* or *GetFileResult[].RemoveError* is TRUE as the result of downloading files, *Error* changes to TRUE, the corresponding error code for the first error is stored in *ErrorID* and the error response from the FTP server is stored in *ErrorIDEx*.

Specifying Options for FTP Server Processing

The operation specified with *ExecOption* is performed to download files from the FTP server.

The data type of *ExecOption* is structure `_sFTP_EXEC_OPTION`. The specifications are as follows:

Name	Meaning	Description	Data type	Valid range	Unit	Default
ExecOption	FTP execution options	Options for FTP execution	<code>_sFTP_EXEC_OPTION</code>	---	---	---
PassiveMode	Passive mode specification	TRUE: Passive mode FALSE: Active mode	BOOL	Depends on data type.	---	FALSE
ASCIIMode	ASCII mode specification	TRUE: ASCII mode FALSE: Binary mode	BOOL			
FileRemove	File deletion after transfer specification*1	TRUE: Delete files after transfer. FALSE: Do not delete files after transfer.	BOOL			
OverWrite	Overwrite specification	TRUE: Overwrite files at transfer destination. FALSE: Do not overwrite files at transfer destination.	BOOL			
Reserved	Reserved	Reserved by the system.	ARRAY[0..7] Of Byte			

*1 The transfer source files are not deleted when the transfer fails.

The meanings of the options are described next.

● *PassiveMode* (Passive Mode Specification)

The passive mode specification tells whether to use passive mode for the data connection request to the FTP server. If passive mode is not specified, active mode is used for the data connection request to the FTP server.

Refer to the *NJ/NX-series CPU Unit Built-in EtherNet/IP Port User's Manual* (Cat. No. W506) or *NY-series Industrial Panel PC / Industrial Box PC Built-in EtherNet/IP Port User's Manual* (Cat. No. W563) for details on connection request methods.

The values and their meanings for *PassiveMode* are given in the following table.

Set value	Meaning
TRUE	The data connection request with the FTP server is performed in passive mode. The data connection request is performed from the FTP client.
FALSE	The data connection request with the FTP server is performed in active mode. The data connection request is performed from the FTP server.

● **ASCII Mode (ASCII Mode Specification)**

The ASCII mode specification tells whether ASCII mode is used as the transfer mode from the transfer source system to the transfer destination system. If ASCII mode is not specified, binary mode is used as the transfer mode from the transfer source system to the transfer destination system.

The values and their meanings for *ASCII Mode* are given in the following table.

Set value	Meaning
TRUE	ASCII mode is used as the transfer mode from the transfer source system to the transfer destination system. Text line feed codes are converted from those for the transfer source system to those for the transfer destination system.
FALSE	Binary mode is used as the transfer mode from the transfer source system to the transfer destination system. Text line feed codes are transferred as is from the transfer source system.

● **File Remove (File Deletion after Transfer Specification)**

The file deletion after transfer specification tells whether to delete the transfer source files after they are transferred to the transfer destination.

The values and their meanings for *File Remove* are given in the following table.

Set value	Meaning
TRUE	The transfer source files are deleted.
FALSE	The transfer source files are not deleted.

● **OverWrite (Overwrite Specification)**

The overwrite specification tells whether to overwrite files with the same name at the transfer destination when files are downloaded. If overwriting is not specified, files with the same name as those at the transfer destination are not transferred.

File names are not case sensitive.

The values and their meanings for *OverWrite* are given in the following table.

Set value	Meaning
TRUE	The transfer destination files are overwritten.
FALSE	The transfer destination files are not overwritten. The files are not transferred to the transfer destination.

Specifying Retrying Connection Processing with the FTP Server

You can specify retrying connection processing with the FTP server.

The operation for the retry settings is the same as that for the FTPGetFileList instruction (page 2-1135). Refer to the specified page for details.

Canceling Instruction Execution

You can cancel execution of the FTPGetFile instruction after execution has started.

The results of downloading files from the FTP server up to the point where it is canceled are stored in *GetNum* and *GetFileResult[]*.

The operation for cancellation is the same as that for the FTPGetFileList instruction (page 2-1135). Refer to the specified page for details.

Related System-defined Variables

Name	Meaning	Data type	Description
_EIP_EtnOnlineSta* ¹	Online	BOOL	This variable indicates when built-in EtherNet/IP port communications can be used. TRUE: Communications are possible. FALSE: Communications are not possible.
_EIP1_EtnOnlineSta* ²			
_EIP2_EtnOnlineSta* ³			
_EIPIn1_EtnOnlineSta* ⁴			
_Card1Ready	SD Memory Card Ready Flag	BOOL	This variable indicates whether the SD Memory Card is recognized and usable. TRUE: Can be used. FALSE: Cannot be used.

*1 Use this variable name for an NJ-series CPU Unit.

*2 Use this variable name for port 1 on an NX-series CPU Unit, or for an NY-series Controller.

*3 Use this variable name for port 2 on an NX-series CPU Unit.

*4 Use this variable name for the internal port on an NY-series Controller.

Precautions for Correct Use

- This instruction can be used only for the built-in EtherNet/IP ports on NJ/NX-series CPU Units and NY-series Controllers.
- Execution of this instruction is continued until processing is completed even if the value of *Execute* changes to FALSE or the execution time exceeds the task period. The value of *Done* changes to TRUE when processing is completed. Use this to confirm normal completion of processing.
- Refer to Using this Section (page 2-3) for a timing chart for *Execute*, *Done*, *Busy*, and *Error*.
- If the number of downloaded file results to store exceeds the number of array elements in *GetFileResult[]*, the results that will not fit are not stored. In this case, *Error* does not change to TRUE.
- If a file name exceeds 255 characters, the first 255 characters are stored in *Name* in *GetFileResult[]*. In this case, *Error* does not change to TRUE.
- You can execute a maximum of 3 of the following instructions at the same time: FTPGetFileList, FTPGetFile, FTPPutFile, FTPRemoveFile, and FTPRemoveDir.
- If a wildcard is used in the file name and an error occurs for more than one file, the results of the first file for which the value of *GetFileResult[]*.*TxError* is TRUE of all the files for which results are stored in *GetFileResult[]* are stored in *ErrorID* and *ErrorIDEx*.
- File names are not case sensitive. Therefore, if the only difference between the names of the files at the transfer destination and the transfer files is in capitalization, the files are detected as having the same names. The following is performed in this case.

Value of <i>OverWrite</i>	Overwrite specification	Processing
TRUE	Overwrite	The files are overwritten.
FALSE	Do not overwrite.	The transfer destination files are not overwritten. The files are not transferred to the transfer destination.

- If the file specified by *FileName* does not exist in the specified directory on the FTP server, a transfer error occurs and the value of *GetFileResult[]*.*TxError* changes to TRUE.
- If the name specified for *FileName* is actually the name of a directory, a transfer error occurs and the value of *GetFileResult[]*.*TxError* changes to TRUE.
- If *ExecOption.FileRemove* is TRUE and the file specified with *FileName* has a read-only attribute, a deletion error occurs and *GetFileResult[]*.*RemoveError* changes to TRUE.

- An error will occur in the following cases. *Error* will change to TRUE.
 - The value of any input parameter is outside of the valid range.
 - “..” is specified for a directory level in *SvrDirName* or *LocalDirName*.
 - An incorrect path such as “//” is specified for *SvrDirName* or *LocalDirName*.
 - The directory specified by *SvrDirName* does not exist on the FTP server.
 - More than 1,000 files to download exist in the FTP server directory specified with *SvrDirName*.
 - The file directory specified with *FileName* does not exist in the download source directory on the FTP server.
 - *ExecOption.OverWrite* is FALSE and a file with the same name as the specified file name *FileName* already exists in the specified directory *SvrDirName*.
 - *ExecOption.FileRemove* is TRUE but a file with a name that matches *FileName* has a read-only attribute.
 - The FTP server specified by *ConnectSvr* does not exist on the network or the specified FTP server is not operating.
 - Accessing the file specified with *FileName* failed because there is no access right to the file or the file is corrupted.
 - More than 3 of the following instructions were executed at the same time: FTPGetFileList, FTPGetFile, FTPPutFile, FTPRemoveFile, and FTPRemoveDir.
 - The SD Memory Card is not in a usable condition.
 - The SD Memory Card is write protected.
 - There is insufficient space available on the SD Memory Card.
 - The maximum number of files or directories was exceeded on the SD Memory Card.
- For this instruction, expansion error code *ErrorIDEx* gives the FTP response code that was returned by the FTP server. The following table lists typical values of *ErrorIDEx* and describes the meanings of the errors and the corrections. For details, refer to FTP server specifications. An expansion error code is output to *ErrorIDEx* when the value of error code *ErrorID* is WORD#16#2407.

Value of <i>ErrorIDEx</i>	Meaning	Correction
16#000001A9	It was not possible to establish a data connection.	If you use FTP communications with an FTP server over the Internet, make sure that the FTP open mode is not set to active.
16#000001AA	The connection was closed. Data transfer was aborted.	Check the connection to the FTP server. Make sure that the FTP server is operating.
16#000001C2	It was not possible to perform the requested file operation. Using the file was not possible, e.g., it is already open.	Make sure that the file is not open for any other application.
16#00000212	User login was not possible.	Check the FTP user name and password.
16#00000214	An account to save files is required.	Check the FTP user access rights.
16#00000226	Execution of the requested file operation was not possible because using the file was not possible, e.g., accessing it was not possible because it was not found.	Make sure that a file with the specified name exists in the directory on the FTP server. Check the access rights of the specified file.
16#00000229	Execution was not possible because the file name was not correct.	Check the access rights of the specified directory.



Version Information

A CPU Unit with unit version 1.08 or later and Sysmac Studio version 1.09 or higher are required to use this instruction.

Sample Programming

Refer to the sample programming for the FTPGetFileList instruction (page 2-1135).

FTPputFile

The FTPputFile instruction uploads a file to the FTP server.

Instruction	Name	FB/FUN	Graphic expression	ST expression
FTPputFile	Put File onto FTP Server	FB		<pre>FTPputFile_instance(Execute, ConnectSvr, SvrDirName, LocalDirName, FileName, ExecOption, RetryCfg, Cancel, PutFileResult, Done, Busy, CommandCanceled, Error, ErrorID, ErrorIDEx, PutNum);</pre>

Variables

Name	Meaning	I/O	Description	Valid range	Unit	Default
Connect Svr	Connected FTP server settings	Input	Setting parameters for the connected FTP server	---		*1
SvrDir Name	FTP server directory name		Name of FTP server directory to which to upload a file	256 bytes max. (255 single-byte alphanumeric characters plus the final NULL character)*2		**3
LocalDir Name	Local directory name		Name of the directory in which to store the file uploaded to the FTP server	256 bytes max. (255 single-byte alphanumeric characters plus the final NULL character)	---	'/'
FileName	File name		Name of file to upload*4			*1
Exec Option	FTP execution options		Options for FTP execution			
RetryCfg	Execution retry settings		Instruction execution retry settings	---		---
Cancel	Cancel		TRUE: Instruction execution is canceled. FALSE: Instruction execution is not canceled.	Depends on data type.		FALSE

Name	Meaning	I/O	Description	Valid range	Unit	Default
PutFileResult[] array*5*6*7	Uploaded file results	In-out	Uploaded file results	---	---	*1
CommandCanceled	Cancel completed	Output	TRUE: Canceling completed. FALSE: Canceling not completed.	Depends on data type.	---	---
PutNum	Number of files to upload		Number of files to upload	---		

- *1 If you omit an input parameter, the default value is not applied. A building error will occur.
- *2 You cannot use the following characters in FTP server directory names: * ? < > | "
- *3 The default is the home directory when you log onto the FTP server.
- *4 You can use wildcards in file names.
- *5 The array can have a maximum of 1,000 elements.
- *6 This is a one-dimensional array. If an array with more than one dimension is specified, a building error will occur.
- *7 The first array element number is 0. If a number other than 0 is specified for the first array element, a building error will occur.

	Boolean	Bit strings				Integers							Real numbers		Times, durations, dates, and text strings					
	BOOL	BYTE	WORD	DWORD	LWORD	USINT	UINT	UDINT	ULINT	SINT	INT	DINT	LINT	REAL	LREAL	TIME	DATE	TOD	DT	STRING
ConnectSvr	Refer to <i>Function</i> for details on the structure <code>_sFTP_CONNECT_SVR</code> .																			
SvrDirName																				OK
LocalDirName																				OK
FileName																				OK
ExecOption	Refer to <i>Function</i> for details on the structure <code>_sFTP_EXEC_OPTION</code> .																			
RetryCfg	Refer to <i>Function</i> for details on the structure <code>_sFTP_RETRY_CFG</code> .																			
Cancel	OK																			
PutFileResult[] array	Refer to <i>Function</i> for details on the structure <code>_sFTP_FILE_RESULT</code> .																			
CommandCanceled	OK																			
PutNum							OK													

Function

The FTPPutFile instruction uploads the file specified with *FileName* in the specified directory *LocalDirName* in the SD Memory Card to the directory specified with *SvrDirName* on the connected FTP server *ConnectSvr*. If the specified directory *SvrDirName* does not exist on the FTP server, a new directory is created and the specified file is uploaded.

You can use wildcards in *FileName*. This allows you to upload more than one file at one time.

The results of uploading is stored in *PutFileResult[]* for each file. Store the number of files to upload in *PutNum*. If you use a wildcard in *FileName*, store the number of files with names that match the wildcard.

If the actual number of transferred files is different, the value of *PutFileResult[]*.TxError changes to TRUE.

If an error occurs when deleting the source file after the upload, the value of `PutFileResult[].RemoveError` changes to TRUE.

With an NY-series Controller, files are downloaded into the shared folder (Virtual SD Memory Card). Before downloading files to the Virtual SD Memory Card, you must make the settings for the Virtual SD Memory Card. Refer to the *NY-series Industrial Panel PC / Industrial Box PC Software User's Manual* (Cat. No. W558) for details on a Virtual SD Memory Card.

The data type of `ConnectSvr` is structure `_sFTP_CONNECT_SVR`. The specifications are as follows:

Name	Meaning	Description	Data type	Valid range	Unit	Default
ConnectSvr	Connected FTP server settings	Setting parameters for the connected FTP server	<code>_sFTP_CONNECT_SVR</code>	---	---	---
Adr	Address	IP address or host name*1	STRING	1 to 200 bytes*2	---	---
PortNo	Port number	TCP port number of FTP server control connection	UINT	0 to 65535*3		
UserName	User name	User name on FTP server	STRING	33 bytes max.*4*5*6		
Password	Password	FTP server password	STRING	33 bytes max.*4*5*6		

*1 A separate DNS or Hosts setting is required to specify a host name.

*2 You can use the following single-byte characters: A to Z, a to z, 0 to 9, - (hyphen), . (period), and _ (underbar).

*3 If you specify 0, TCP port number 21 is used.

*4 You can use the following single-byte characters: A to Z, a to z, 0 to 9, - (hyphen), . (period), and _ (underbar). You can also use \ and @ for a CPU Unit with unit version 1.16 or later.

*5 The NULL character at the end must be counted in the number of bytes.

*6 For CPU Units with unit version 1.08, specify a text string of one character or more. An error will occur if you specify a text string that contains only the final NULL character.

The data type of `PutFileResult[]` is structure `_sFTP_FILE_RESULT`. The specifications are as follows:

Name	Meaning	Description	Data type	Valid range	Unit	Default
PutFileResult	Uploaded file results	Transferred file results	<code>_sFTP_FILE_RESULT</code>	---	---	---
Name	File name*1	Transferred file name	STRING	256 bytes max. (255 single-byte alphanumeric characters plus the final NULL character)	---	---
TxError	Transfer error	TRUE: Transfer ended in an error. FALSE: Transfer ended normally.	BOOL	Depends on data type.		
RemoveError	Deletion error	TRUE: Deletion ended in an error. FALSE: Deletion ended normally.	BOOL			
Reserved	Reserved	Reserved by the system.	ARRAY[0..3] Of Byte	---		

*1 The file name extension is included.

Using Wildcards to Specify File Names

You can use wildcards to specify the names of the files to upload.

Wildcard specifications are the same as those for the FTPGetFile instruction (page 2-1152). Refer to the specified page for details.

Specifying Options for FTP Server Processing

You can specify FTP server processing options when you upload files.

The option settings are the same as those for the FTPGetFile instruction (page 2-1152). Refer to the specified page for details.

Specifying Retrying Connection Processing with the FTP Server

You can specify retrying connection processing with the FTP server.

The operation for the retry settings is the same as that for the FTPGetFileList instruction (page 2-1135). Refer to the specified page for details.

Canceling Instruction Execution

You can cancel execution of the FTPPutFile instruction after execution has started.

The results of uploading files from the FTP server up to the point where it is canceled are stored in *Put-Num* and *PutFileResult[]*.

The operation for cancellation is the same as that for the FTPGetFileList instruction (page 2-1135). Refer to the specified page for details.

Related System-defined Variables

Name	Meaning	Data type	Description
_EIP_EtnOnlineSta* ¹	Online	BOOL	This variable indicates when built-in EtherNet/IP port communications can be used. TRUE: Communications are possible. FALSE: Communications are not possible.
_EIP1_EtnOnlineSta* ²			
_EIP2_EtnOnlineSta* ³			
_EIPIn1_EtnOnlineSta* ⁴			
_Card1Ready	SD Memory Card Ready Flag	BOOL	This variable indicates whether the SD Memory Card is recognized and usable. TRUE : Can be used. FALSE: Cannot be used.

*1 Use this variable name for an NJ-series CPU Unit.

*2 Use this variable name for port 1 on an NX-series CPU Unit, or for an NY-series Controller.

*3 Use this variable name for port 2 on an NX-series CPU Unit.

*4 Use this variable name for the internal port on an NY-series Controller.

Precautions for Correct Use

- This instruction can be used only for the built-in EtherNet/IP ports on NJ/NX-series CPU Units and NY-series Controllers.
- Execution of this instruction is continued until processing is completed even if the value of *Execute* changes to FALSE or the execution time exceeds the task period. The value of *Done* changes to TRUE when processing is completed. Use this to confirm normal completion of processing.
- Refer to Using this Section (page 2-3) for a timing chart for *Execute*, *Done*, *Busy*, and *Error*.
- If the number of uploaded file results to store exceeds the number of array elements in *PutFileResult[]*, the results that will not fit are not stored. In this case, *Error* does not change to TRUE.
- If a file name exceeds 255 characters, the first 255 characters are stored in *Name* in *PutFileResult[]*. In this case, *Error* does not change to TRUE.
- You can execute a maximum of 3 of the following instructions at the same time: FTPGetFileList, FTPGetFile, FTPPutFile, FTPRemoveFile, and FTPRemoveDir.
- If a wildcard is used in the file name and an error occurs for more than one file, the results of the first file for which the value of *PutFileResult[].TxError* is TRUE of all the files for which results are stored in *PutFileResult[]* are stored in *ErrorID* and *ErrorIDEx*.
- File names are not case sensitive. Therefore, if the only difference between the names of the files at the transfer destination and the transfer files is in capitalization, the files are detected as having the same names. The following is performed in this case.

Value of Over-Write	Overwrite specification	Processing
TRUE	Overwrite	If overwriting is not specified, the operation depends on the FTP server specifications.
FALSE	Do not overwrite.	The transfer destination files are not overwritten. The files are not transferred to the transfer destination.

- If the file specified by *FileName* does not exist in the specified directory on the SD Memory Card, a transfer error occurs and the value of *PutFileResult[].TxError* changes to TRUE.
- If the name specified for *FileName* is actually the name of a directory, a transfer error occurs and the value of *PutFileResult[].TxError* changes to TRUE.
- If *ExecOption.FileRemove* is TRUE and the file specified with *FileName* has a read-only attribute, a deletion error occurs and the value of *PutFileResult[].RemoveError* changes to TRUE.

- An error will occur in the following cases. *Error* will change to TRUE.
 - The value of any input parameter is outside of the valid range.
 - “..” is specified for a directory level in *SvrDirName* or *LocalDirName*.
 - An incorrect path such as “/” is specified for *SvrDirName* or *LocalDirName*.
 - The directory specified by *SvrDirName* does not exist on the FTP server.
 - The directory specified by *LocalDirName* does not exist on the FTP client.
 - More than 1,000 files to upload exist in the directory specified with *LocalDirName*.
 - The file directory specified with *FileName* does not exist in the upload source directory on the SD Memory Card.
 - *ExecOption.OverWrite* is FALSE and a file with the same name as the specified file name *FileName* already exists in the specified directory *SvrDirName*.
 - *ExecOption.FileRemove* is TRUE but a file with a name that matches *FileName* has a read-only attribute.
 - The FTP server specified by *ConnectSvr* does not exist on the network or the specified FTP server is not operating.
 - Accessing the file specified with *FileName* failed because there is no access right to the file or the file is corrupted.
 - More than 3 of the following instructions were executed at the same time: FTPGetFileList, FTPGetFile, FTPPutFile, FTPRemoveFile, and FTPRemoveDir.
 - The SD Memory Card is not in a usable condition.
- For this instruction, expansion error code *ErrorIDEx* gives the FTP response code that was returned by the FTP server. The following table lists typical values of *ErrorIDEx* and describes the meanings of the errors and the corrections. For details, refer to FTP server specifications. An expansion error code is output to *ErrorIDEx* when the value of error code *ErrorID* is WORD#16#2407.

Value of <i>ErrorIDEx</i>	Meaning	Correction
16#000001A9	It was not possible to establish a data connection.	If you use FTP communications with an FTP server over the Internet, make sure that the FTP open mode is not set to active.
16#000001AA	The connection was closed. Data transfer was aborted.	Check the connection to the FTP server. Make sure that the FTP server is operating.
16#000001C2	It was not possible to perform the requested file operation. Using the file was not possible, e.g., it is already open.	Make sure that the file is not open for any other application.
16#00000212	User login was not possible.	Check the FTP user name and password.
16#00000214	An account to save files is required.	Check the FTP user access rights.
16#00000226	Execution of the requested file operation was not possible because using the file was not possible, e.g., accessing it was not possible because it was not found.	Make sure that a file with the specified name exists in the directory on the FTP server. Check the access rights of the specified file.
16#00000229	Execution was not possible because the file name was not correct.	Check the access rights of the specified directory.

Version Information

A CPU Unit with unit version 1.08 or later and Sysmac Studio version 1.09 or higher are required to use this instruction.

Sample Programming

This programming executes an SD Memory Card backup and then uploads all of the backup-related files to the /Backup/yyyy-mm-dd directory on the FTP server.

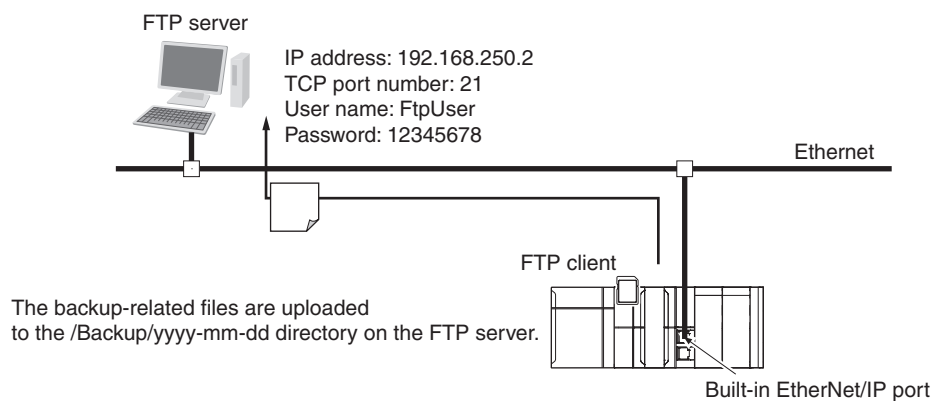

The Controller is connected to the FTP server through an EtherNet/IP network. The settings of the parameters to connect to the FTP server are given in the following table.

Parameter	Value
IP address	192.168.250.2
TCP port number	21
User name	FtpUser
Password	12345678

The following procedure is used.

- 1** The BackupToMemoryCard instruction is used to save NJ/NX-series Controller backup-related files to the root directory on the SD Memory Card.
- 2** The FTPPutFile instruction is used to upload the backup-related files to the /Backup/yyyy-mm-dd directory on the FTP server.
The wildcard specification *.* is used to specify the names of the files to transfer.
- 3** Normal end processing is executed if all processing ends normally. Processing for an error end is performed if an error occurs.

LD

Internal Variables	Variable	Data type	Initial value	Comment
	FTPPutFile_instance	FTPPutFile		Instance of FTPPutFile instruction
	FTPAddr	_sFTP_CONNECT_SVR	(Adr := ", PortNo := 0, UserName := ", Password := ")	Connected FTP server settings
	PutResult	ARRAY[0..0] OF _sFTP_FILE_RESULT	[(Name := ", TxError := False, RemoveError := False, Reserved := [4(16#0)])]	Uploaded file results
	RS_instance	RS		Instance of RS instruction
	OperatingEnd	BOOL	FALSE	Processing completed
	Trigger	BOOL	FALSE	Execution condition
	Operating	BOOL	FALSE	Processing
	BackupToMemoryCard_instance	BackupToMemoryCard		Instance of BackupToMemoryCard instruction

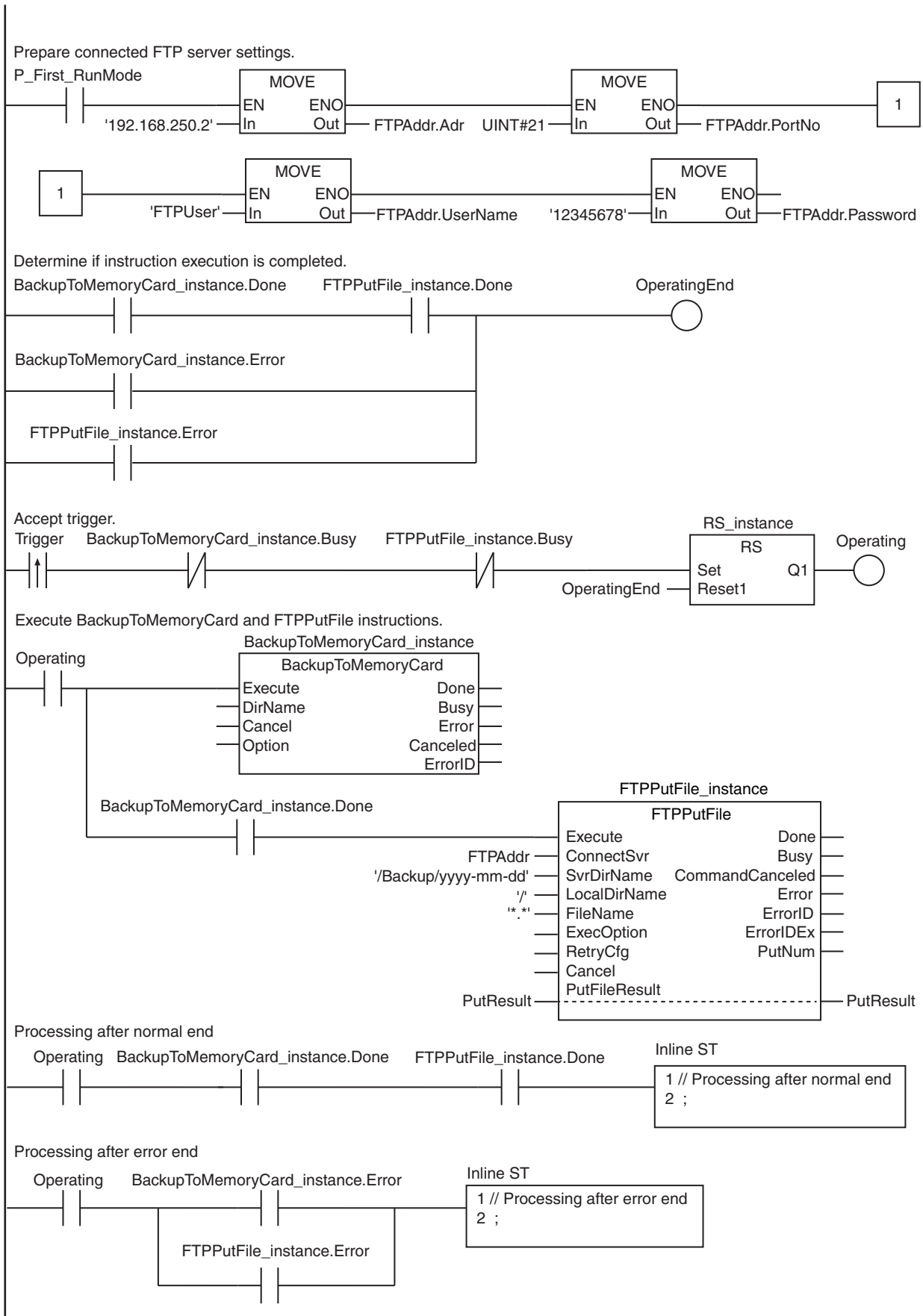

ST

Internal Variables	Variable	Data type	Initial value	Comment
	R_TRIG_instance	R_TRIG		Instance of R_TRIG instruction
	UP_Q	BOOL	FALSE	Trigger output
	FTPputFile_instance	FTPputFile		Instance of FTPputFile instruction
	DoFTPTrigger	BOOL	FALSE	Execution condition for BackupToMemoryCard and FTPputFile
	FTPAddr	_sFTP_CONNECT_SVR	(Adr := ", PortNo := 0, UserName := ", Password := ")	Connected FTP server settings
	PutResult	ARRAY[0..0] OF _sFTP_FILE_RESULT	[(Name := ", TxError := False, RemoveError := False, Reserved := [4(16#0)])]	Uploaded file results
	Stage	UINT	0	Instruction execution stage
	Trigger	BOOL	FALSE	Execution condition
	BackupToMemoryCard_instance	BackupToMemoryCard		Instance of BackupToMemoryCard instruction

```

// Prepare connected FTP server settings.
IF P_First_RunMode THEN
  FTPAddr.Adr      := '192.168.250.2'; // Address
  FTPAddr.PortNo  := UINT#21;         // Port number
  FTPAddr.UserName := 'FtpUser';      // User name
  FTPAddr.Password := '12345678';     // Password
END_IF;

// Accept trigger.
R_TRIG_instance(Trigger, UP_Q);
IF ( (UP_Q = TRUE) AND (BackupToMemoryCard_instance.Busy = FALSE) AND
    (FTPputFile_instance.Busy = FALSE) ) THEN
  DoFTPTrigger := TRUE;
  Stage := INT#1;
  BackupToMemoryCard_instance( // Initialize instance.
    Execute := FALSE);
  FTPputFile_instance( // Initialize instance.
    Execute      := FALSE,
    ConnectSvr   := FTPAddr,
    SvrDirName   := '/Backup/yyyy-mm-dd',
    LocalDirName := '/',
    FileName     := '*.*',
    PutFileResult := PutResult);
END_IF;

IF (DoFTPTrigger = TRUE) THEN
  CASE Stage OF
    1: // Execute BackupToMemoryCard instruction.
      BackupToMemoryCard_instance(
        Execute := TRUE, // Execution
        IF (BackupToMemoryCard_instance.Done = TRUE) THEN
          Stage := INT#2; // To next stage
        ELSIF (BackupToMemoryCard_instance.Error = TRUE) THEN
          Stage := INT#10; // Error end
        END_IF;
    2: // Execute FTPputFile instruction.
  
```

```

FTPputFile_instance(
    Execute           := TRUE,           // Execution
    ConnectSvr       := FTPAddr,       // Connected FTP server
    SvrDirName        := '/Backup/yyyy-mm-dd', // FTP server directory name
    LocalDirName      := '/',           // Local directory name
    FileName          := '*.*',         // File name
    PutFileResult     := PutResult) ;   // Uploaded file results
IF (FTPputFile_instance.Done = TRUE) THEN
    Stage := INT#0; // Normal end
ELSIF (FTPputFile_instance.Error = TRUE) THEN
    Stage := INT#20; // Error end
END_IF;
0: // Processing after normal end
DoFTPTrigger:=FALSE;
Trigger      :=FALSE;
ELSE // Processing after error end
DoFTPTrigger:=FALSE;
Trigger      :=FALSE;
END_CASE;
END_IF;

```

FTPRemoveFile

The FTPRemoveFile instruction deletes a file from the FTP server.

Instruction	Name	FB/FUN	Graphic expression	ST expression
FTPRemove File	Delete FTP Server File	FB		<pre>FTPRemoveFile_instance(Execute, ConnectSvr, SvrDirName, FileName, ExecOption, RetryCfg, Cancel, RemoveFileResult, Done, Busy, CommandCanceled, Error, ErrorID, ErrorIDEx, RemoveNum);</pre>

Variables

Name	Meaning	I/O	Description	Valid range	Unit	Default
Connect Svr	Connected FTP server settings	Input	Setting parameters for the connected FTP server	---	---	*1
SvrDir Name	FTP server directory name		Name of FTP server directory containing the file to delete	256 bytes max. (255 single-byte alphanumeric characters plus the final NULL character)*2		**3
FileName	File name		Name of file to delete*4	256 bytes max. (255 single-byte alphanumeric characters plus the final NULL character)*5		*1
Exec Option	FTP execution options		Options for FTP execution	---		---
RetryCfg	Execution retry settings		Instruction execution retry settings			
Cancel	Cancel		TRUE: Instruction execution is canceled. FALSE: Instruction execution is not canceled.	Depends on data type.		---

Name	Meaning	I/O	Description	Valid range	Unit	Default
Remove FileResult []array*6*7*8	Deleted file results	In-out	Deleted file results	---	---	*1
Command Canceled	Cancel completed	Output	TRUE: Canceling completed. FALSE: Canceling not completed.	Depends on data type.	---	---
Remove Num	Number of files to delete		Number of files to delete	---		

- *1 If you omit an input parameter, the default value is not applied. A building error will occur.
- *2 You cannot use the following characters in FTP server directory names: * ? < > | "
- *3 The default is the home directory when you log onto the FTP server.
- *4 You can use wildcards in file names.
- *5 You cannot use the following character in file names: |
- *6 The array can have a maximum of 1,000 elements.
- *7 This is a one-dimensional array. If an array with more than one dimension is specified, a building error will occur.
- *8 The first array element number is 0. If a number other than 0 is specified for the first array element, a building error will occur.

	Boolean	Bit strings				Integers							Real numbers		Times, durations, dates, and text strings					
	BOOL	BYTE	WORD	DWORD	LWORD	USINT	UINT	UDINT	ULINT	SINT	INT	DINT	LINT	REAL	LREAL	TIME	DATE	TOD	DT	STRING
ConnectSvr	Refer to <i>Function</i> for details on the structure <code>_sFTP_CONNECT_SVR</code> .																			
SvrDirName																				OK
FileName																				OK
ExecOption	Refer to <i>Function</i> for details on the structure <code>_sFTP_EXEC_OPTION</code> .																			
RetryCfg	Refer to <i>Function</i> for details on the structure <code>_sFTP_RETRY_CFG</code> .																			
Cancel	OK																			
Remove FileResult[] array	Refer to <i>Function</i> for details on the structure <code>_sFTP_FILE_RESULT</code> .																			
Command Canceled	OK																			
RemoveNum							OK													

Function

The FTPRemoveFile instruction deletes the file specified by *FileName* in the specified directory *SvrDirName* on the connected FTP server *ConnectSvr*.

You can use wildcards in *FileName*. This allows you to delete more than one file at one time.

The results of deleting files is stored by file in *RemoveFileResult[]*. Store the number of files to delete in *RemoveNum*. If you use a wildcard in *FileName*, store the number of files with names that match the wildcard.

If the actual number of deleted files is different, the value of *RemoveFileResult[].RemoveError* changes to TRUE.

The data type of *ConnectSvr* is structure `_sFTP_CONNECT_SVR`. The specifications are as follows:

Name	Meaning	Description	Data type	Valid range	Unit	Default
ConnectSvr	Connected FTP server settings	Setting parameters for the connected FTP server	<code>_sFTP_CONNECT_SVR</code>	---	---	---
Adr	Address	IP address or host name*1	STRING	1 to 200 bytes*2	---	---
PortNo	Port number	TCP port number of FTP server control connection	UINT	0 to 65535*3		
UserName	User name	User name on FTP server	STRING	33 bytes max.*4*5*6		
Password	Password	FTP server password	STRING	33 bytes max.*4*5*6		

*1 A separate DNS or Hosts setting is required to specify a host name.

*2 You can use the following single-byte characters: A to Z, a to z, 0 to 9, - (hyphen), . (period), and _ (underscore).

*3 If you specify 0, TCP port number 21 is used.

*4 You can use the following single-byte characters: A to Z, a to z, 0 to 9, - (hyphen), . (period), and _ (underscore). You can also use \ and @ for a CPU Unit with unit version 1.16 or later.

*5 The NULL character at the end must be counted in the number of bytes.

*6 For CPU Units with unit version 1.08, specify a text string of one character or more. An error will occur if you specify a text string that contains only the final NULL character.

The data type of *RemoveFileResult[]* is structure `_sFTP_FILE_RESULT`. The specifications are as follows:

Name	Meaning	Description	Data type	Valid range	Unit	Default
RemoveFile Result	Deleted file results	Transferred file results	<code>_sFTP_FILE_RESULT</code>	---	---	---
Name	File name*1	Transferred file name	STRING	256 bytes max. (255 single-byte alphanumeric characters plus the final NULL character)	---	---
TxError	Transfer error	TRUE: Transfer ended in an error. FALSE: Transfer ended normally.	BOOL	Depends on data type.		
RemoveError	Deletion error	TRUE: Deletion ended in an error. FALSE: Deletion ended normally.	BOOL			
Reserved	Reserved	Reserved by the system.	ARRAY[0..3] Of Byte	---		

*1 The file name extension is included.

Using Wildcards to Specify File Names

You can use wildcards to specify the names of the files to delete.

Wildcard specifications are the same as those for the `FTPGetFile` instruction (page 2-1152). Refer to the specified page for details.

Specifying Options for FTP Server Processing

The operation specified with *ExecOption* is performed to delete the files from the FTP server.

The option settings are the same as those for the FTPGetFile instruction (page 2-1152). Refer to the specified page for details.

However, the only option that is valid for this instruction is *ExecOption.PassiveMode*.

Specifying Retrying Connection Processing with the FTP Server

You can specify retrying connection processing with the FTP server.

The operation for the retry settings is the same as that for the FTPGetFileList instruction (page 2-1135). Refer to the specified page for details.

Canceling Instruction Execution

You can cancel execution of the FTPRemoveFile instruction after execution has started.

The results of deleting files from the FTP server up to the point where it is canceled are stored in *RemoveNum* and *RemoveFileResult[]*.

The operation for cancellation is the same as that for the FTPGetFileList instruction (page 2-1135). Refer to the specified page for details.

Related System-defined Variables

Name	Meaning	Data type	Description
_EIP_EtnOnlineSta*1	Online	BOOL	This variable indicates when built-in EtherNet/IP port communications can be used. TRUE: Communications are possible. FALSE: Communications are not possible.
_EIP1_EtnOnlineSta*2			
_EIP2_EtnOnlineSta*3			
_EIPIn1_EtnOnlineSta*4			

*1 Use this variable name for an NJ-series CPU Unit.

*2 Use this variable name for port 1 on an NX-series CPU Unit, or for an NY-series Controller.

*3 Use this variable name for port 2 on an NX-series CPU Unit.

*4 Use this variable name for the internal port on an NY-series Controller.

Precautions for Correct Use

- This instruction can be used only for the built-in EtherNet/IP ports on NJ/NX-series CPU Units.
- Execution of this instruction is continued until processing is completed even if the value of *Execute* changes to FALSE or the execution time exceeds the task period. The value of *Done* changes to TRUE when processing is completed. Use this to confirm normal completion of processing.
- Refer to Using this Section (page 2-3) for a timing chart for *Execute*, *Done*, *Busy*, and *Error*.
- If the number of deleted files exceeds the number of array elements in *RemoveFileResult[]*, the results that will not fit are not stored. In this case, *Error* does not change to TRUE.
- If a file name exceeds 255 characters, the first 255 characters are stored in *Name* in *RemoveFileResult[]*. In this case, *Error* does not change to TRUE.
- You can execute a maximum of 3 of the following instructions at the same time: FTPGetFileList, FTPGetFile, FTPPutFile, FTPRemoveFile, and FTPRemoveDir.

- If a wildcard is used in the file name and an error occurs for more than one file, the results of the first file for which the value of *RemoveFileResult[]*.*TxError* is TRUE of all the files for which results are stored in *RemoveFileResult[]* are stored in *ErrorID* and *ErrorIDEx*.
- In the following cases, the value of *RemoveFileResult[]*.*RemoveError* changes to TRUE.
 - The file directory specified with *FileName* does not exist on the FTP server.
 - A file specified with *FileName* has a read-only attribute.
 - The name specified for *FileName* is actually the name of a directory.
- An error will occur in the following cases. *Error* will change to TRUE.
 - The value of any input parameter is outside of the valid range.
 - “.” is specified for a directory level in *SvrDirName*.
 - An incorrect path such as “/” is specified for *SvrDirName*.
 - The directory specified by *SvrDirName* does not exist on the FTP server.
 - More than 1,000 files to delete exist in the directory specified with *SvrDirName*.
 - A file that matches the file name specified with a wildcard in *FileName* does not exist in the directory on the FTP server.
 - A file specified with *FileName* has a read-only attribute.
 - The FTP server specified by *ConnectSvr* does not exist on the network or the specified FTP server is not operating.
 - More than 3 of the following instructions were executed at the same time: FTPGetFileList, FTPGetFile, FTPPutFile, FTPRemoveFile, and FTPRemoveDir.
- For this instruction, expansion error code *ErrorIDEx* gives the FTP response code that was returned by the FTP server. The following table lists typical values of *ErrorIDEx* and describes the meanings of the errors and the corrections. For details, refer to FTP server specifications. An expansion error code is output to *ErrorIDEx* when the value of error code *ErrorID* is WORD#16#2407.

Value of <i>ErrorIDEx</i>	Meaning	Correction
16#000001A9	It was not possible to establish a data connection.	If you use FTP communications with an FTP server over the Internet, make sure that the FTP open mode is not set to active.
16#000001AA	The connection was closed. Data transfer was aborted.	Check the connection to the FTP server. Make sure that the FTP server is operating.
16#000001C2	It was not possible to perform the requested file operation. Using the file was not possible, e.g., it is already open.	Make sure that the file is not open for any other application.
16#00000212	User login was not possible.	Check the FTP user name and password.
16#00000214	An account to save files is required.	Check the FTP user access rights.
16#00000226	Execution of the requested file operation was not possible because using the file was not possible, e.g., accessing it was not possible because it was not found.	Make sure that a file with the specified name exists in the directory on the FTP server. Check the access rights of the specified file.
16#00000229	Execution was not possible because the file name was not correct.	Check the access rights of the specified directory.



Version Information

A CPU Unit with unit version 1.08 or later and Sysmac Studio version 1.09 or higher are required to use this instruction.

Sample Programming

This programming deletes all of the files in the /Backup/yyyy-mm-dd directory on the FTP server. It then deletes the /Backup/yyyy-mm-dd directory too.

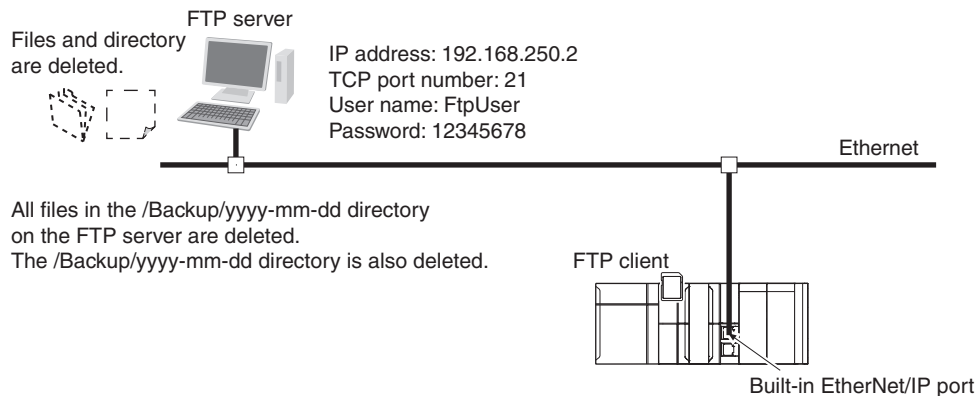

The Controller is connected to the FTP server through an EtherNet/IP network. The settings of the parameters to connect to the FTP server are given in the following table.

Parameter	Value
IP address	192.168.250.2
TCP port number	21
User name	FtpUser
Password	12345678

The following procedure is used.

- 1** The FTPRemoveFile instruction is used to delete all of the files in the /Backup/yyyy-mm-dd directory on the FTP server. The wildcard specification *.* is used to specify the names of the files to delete.
- 2** The FTPRemoveDir instruction is used to delete the /Backup/yyyy-mm-dd directory from the FTP server.
- 3** Normal end processing is executed if all processing ends normally. Processing for an error end is performed if an error occurs.

LD

Internal Variables	Variable	Data type	Initial value	Comment
	FTPRemove-File_instance	FTPRemoveFile		Instance of FTPRemove-File instruction
	FTPRemove-Dir_instance	FTPRemoveDir		Instance of FTPRemove-Dir instruction
	FTPAddr	_sFTP_CONNECT_SVR	(Adr := ", PortNo := 0, UserName := ", Password := ")	Connected FTP server settings
	RemoveResult	ARRAY[0..0] OF _sFTP_FILE_RESULT	[(Name := ", TxError := False, RemoveError := False, Reserved := [4(16#0)])]	Deleted file results
	RS_instance	RS		Instance of RS instruction
	OperatingEnd	BOOL	FALSE	Processing completed
	Trigger	BOOL	FALSE	Execution condition
	Operating	BOOL	FALSE	Processing

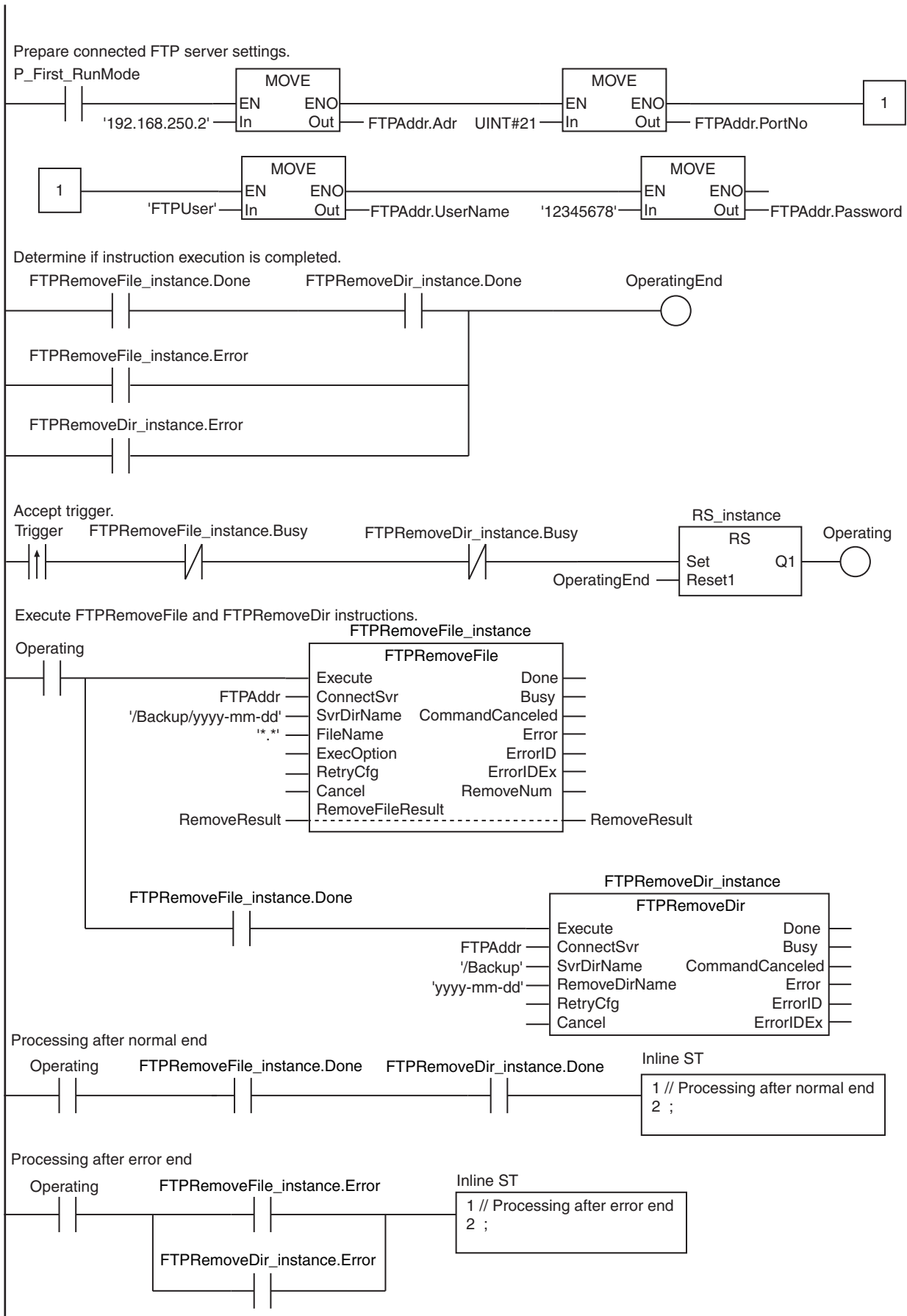

ST

Internal Variables	Variable	Data type	Initial value	Comment
	R_TRIG_instance	R_TRIG		Instance of R_TRIG instruction
	UP_Q	BOOL	FALSE	Trigger output
	FTPRemove-File_instance	FTPRemoveFile		Instance of FTPRemove-File instruction
	FTPRemove-Dir_instance	FTPRemoveDir		Instance of FTPRemove-Dir instruction
	DoFTPTrigger	BOOL	FALSE	Execution condition for FTPRemoveFile and FTPRemoveDir
	FTPAddr	_sFTP_CONNECT_SVR	(Adr := ", PortNo := 0, UserName := ", Password := ")	Connected FTP server settings
	RemoveResult	ARRAY[0..0] OF _sFTP_FILE_RESULT	[(Name := ", TxError := False, RemoveError := False, Reserved := [4(16#0)])]	Deleted file results
	Stage	UINT	0	Instruction execution stage
	Trigger	BOOL	FALSE	Execution condition

```

// Prepare connected FTP server settings.
IF P_First_RunMode THEN
  FTPAddr.Adr      := '192.168.250.2'; // Address
  FTPAddr.PortNo  := UINT#21;         // Port number
  FTPAddr.UserName := 'FtpUser';      // User name
  FTPAddr.Password := '12345678';     // Password
END_IF;

// Accept trigger.
R_TRIG_instance(Trigger, UP_Q);
IF ( (UP_Q = TRUE) AND (FTPRemoveFile_instance.Busy = FALSE) AND
    (FTPRemoveDir_instance.Busy = FALSE) ) THEN
  DoFTPTrigger := TRUE;
  Stage := INT#1;
  FTPRemoveFile_instance( // Initialize instance.
    Execute      := FALSE,
    ConnectSvr   := FTPAddr,
    SvrDirName   := '/Backup/yyyy-mm-dd',
    FileName     := '*.*',
    RemoveFileResult := RemoveResult) ;
  FTPRemoveDir_instance( // Initialize instance.
    Execute      := FALSE,
    ConnectSvr   := FTPAddr,
    SvrDirName   := '/Backup',
    RemoveDirName := 'yyyy-mm-dd') ;
END_IF;

IF (DoFTPTrigger = TRUE) THEN
  CASE Stage OF
    1 : // Execute FTPRemoveFile instruction.
      FTPRemoveFile_instance(
        Execute      := TRUE, // Execution
        ConnectSvr   := FTPAddr, // Connected FTP server
        SvrDirName   := '/Backup/yyyy-mm-dd', //FTP server directory name
        FileName     := '*.*', // File name
        RemoveFileResult := RemoveResult) ; // Deleted file results
  
```



```

IF (FTPRemoveFile_instance.Done = TRUE) THEN
  Stage := INT#2; // To next stage
ELSIF (FTPRemoveFile_instance.Error = TRUE) THEN
  Stage := INT#10; // Error end
END_IF;
2 : // Execute FTPRemoveDir instruction.
  FTPRemoveDir_instance(
    Execute      := TRUE,          // Execution
    ConnectSvr   := FTPAddr,      // Connected FTP server
    SvrDirName   := '/Backup',    // FTP server directory name
    RemoveDirName := 'yyyy-mm-dd') ; // Directory to delete
  IF (FTPRemoveDir_instance.Done = TRUE) THEN
    Stage:=INT#0; // Normal end
  ELSIF (FTPRemoveDir_instance.Error = TRUE) THEN
    Stage:=INT#20; // Error end
  END_IF;
0 : // Processing after normal end
  DoFTPTrigger:=FALSE;
  Trigger      :=FALSE;
ELSE // Processing after error end
  DoFTPTrigger:=FALSE;
  Trigger      :=FALSE;
END_CASE;
END_IF;

```

FTPRemoveDir

The FTPRemoveDir instruction deletes a directory from the FTP server.

Instruction	Name	FB/FUN	Graphic expression	ST expression
FTPRemoveDir	Delete FTP Server Directory	FB		<pre>FTPRemoveDir_instance(Execute, ConnectSvr, SvrDirName, RemoveDirName, Cancel, RetryCfg, Done, Busy, CommandCanceled, Error, ErrorID, ErrorIDEx);</pre>

Variables

Name	Meaning	I/O	Description	Valid range	Unit	Default
Connect Svr	Connected FTP server settings	Input	Setting parameters for the connected FTP server	---	---	*1
SvrDir Name	FTP server directory name		Name of FTP server directory containing the directory to delete	256 bytes max. (255 single-byte alphanumeric characters plus the final NULL character)*2		**3
RemoveDir-Name	Directory to delete		Directory to delete	256 bytes max. (255 single-byte alphanumeric characters plus the final NULL character)		*1
RetryCfg	Execution retry settings		Instruction execution retry settings	---		---
Cancel	Cancel		TRUE: Instruction execution is canceled. FALSE: Instruction execution is not canceled.	Depends on data type.		FALSE
Command-Canceled	Cancel completed	Output	TRUE: Canceling completed. FALSE: Canceling not completed.	---	---	---

*1 If you omit an input parameter, the default value is not applied. A building error will occur.

*2 You cannot use the following characters in FTP server directory names: * ? < > | "

*3 The default is the home directory when you log onto the FTP server.

	Boolean	Bit strings				Integers							Real numbers		Times, durations, dates, and text strings					
	BOOL	BYTE	WORD	DWORD	LWORD	USINT	UINT	UDINT	ULINT	SINT	INT	DINT	LINT	REAL	LREAL	TIME	DATE	TOD	DT	STRING
ConnectSvr	Refer to <i>Function</i> for details on the structure <code>_sFTP_CONNECT_SVR</code> .																			
SvrDirName																				OK
RemoveDirName																				OK
RetryCfg	Refer to <i>Function</i> for details on the structure <code>_sFTP_RETRY_CFG</code> .																			
Cancel	OK																			
Command Canceled	OK																			

Function

The FTPRemoveDir instruction deletes the specified directory *RemoveDirName* from the directory containing the directory to delete *SvrDirName* on the connected FTP server *ConnectSvr*.

When the value of *Done* in the instruction changes to TRUE, deletion of the specified directory is already completed. If the instruction fails to delete the directory, the value of *Error* changes to TRUE.

The data type of *ConnectSvr* is structure `_sFTP_CONNECT_SVR`. The specifications are as follows:

Name	Meaning	Description	Data type	Valid range	Unit	Default
ConnectSvr	Connected FTP server settings	Setting parameters for the connected FTP server	<code>_sFTP_CONNECT_SVR</code>	---	---	---
Adr	Address	IP address or host name*1	STRING	1 to 200 bytes*2	---	---
PortNo	Port number	TCP port number of FTP server control connection	UINT	0 to 65535*3		
UserName	User name	User name on FTP server	STRING	33 bytes max.*4*5*6		
Password	Password	FTP server password	STRING	33 bytes max.*4*5*6		

*1 A separate DNS or Hosts setting is required to specify a host name.

*2 You can use the following single-byte characters: A to Z, a to z, 0 to 9, - (hyphen), . (period), and _ (underbar).

*3 If you specify 0, TCP port number 21 is used.

*4 You can use the following single-byte characters: A to Z, a to z, 0 to 9, - (hyphen), . (period), and _ (underbar). You can also use \ and @ for a CPU Unit with unit version 1.16 or later.

*5 The NULL character at the end must be counted in the number of bytes.

*6 For CPU Units with unit version 1.08, specify a text string of one character or more. An error will occur if you specify a text string that contains only the final NULL character.

Specifying Retrying Connection Processing with the FTP Server

You can specify retrying connection processing with the FTP server.

The operation for retrying is the same as that for the FTPGetFileList instruction (page 2-1135). Refer to the specified page for details.

Canceling Instruction Execution

You can cancel execution of the FTPRemoveDir instruction after execution has started.

The operation for cancellation is the same as that for the FTPGetFileList instruction (page 2-1135). Refer to the specified page for details.

Related System-defined Variables

Name	Meaning	Data type	Description
_EIP_EtnOnlineSta*1	Online	BOOL	This variable indicates when built-in EtherNet/IP port communications can be used. TRUE: Communications are possible. FALSE: Communications are not possible.
_EIP1_EtnOnlineSta*2			
_EIP2_EtnOnlineSta*3			
_EIPIn1_EtnOnlineSta*4			

*1 Use this variable name for an NJ-series CPU Unit.

*2 Use this variable name for port 1 on an NX-series CPU Unit, or for an NY-series Controller.

*3 Use this variable name for port 2 on an NX-series CPU Unit.

*4 Use this variable name for the internal port on an NY-series Controller.

Precautions for Correct Use

- This instruction can be used only for the built-in EtherNet/IP ports on NJ/NX-series CPU Units.
- Execution of this instruction is continued until processing is completed even if the value of *Execute* changes to FALSE or the execution time exceeds the task period. The value of *Done* changes to TRUE when processing is completed. Use this to confirm normal completion of processing.
- Refer to Using this Section (page 2-3) for a timing chart for *Execute*, *Done*, *Busy*, and *Error*.
- Even if you use *Cancel* to cancel the execution of this instruction, sometimes the directory on the FTP server is deleted depending on the timing of when *Cancel* changes to TRUE. Check the directory on the FTP server.
- You can execute a maximum of 3 of the following instructions at the same time: FTPGetFileList, FTPGetFile, FTPPutFile, FTPRemoveFile, and FTPRemoveDir.
- An error will occur in the following cases. *Error* will change to TRUE.
 - The value of any input parameter is outside of the valid range.
 - The directory specified by *SvrDirName* does not exist on the FTP server.
 - “..” is specified for a directory level in *SvrDirName* or *RemoveDirName*.
 - An incorrect path such as “/” is specified for *SvrDirName* or *RemoveDirName*.
 - The directory specified by *RemoveDirName* does not exist on the FTP server.
 - There are no files or subdirectories in the directory specified with *RemoveDirName*.
 - The directory specified with *RemoveDirName* has a read-only attribute.
 - The FTP server specified by *ConnectSvr* does not exist on the network or the specified FTP server is not operating.

- More than 3 of the following instructions were executed at the same time: FTPGetFileList, FTPGetFile, FTPPutFile, FTPRemoveFile, and FTPRemoveDir.
- For this instruction, expansion error code *ErrorIDEx* gives the FTP response code that was returned by the FTP server. The following table lists typical values of *ErrorIDEx* and describes the meanings of the errors and the corrections. For details, refer to FTP server specifications. An expansion error code is output to *ErrorIDEx* when the value of error code *ErrorID* is WORD#16#2407.

Value of <i>ErrorIDEx</i>	Meaning	Correction
16#000001A9	It was not possible to establish a data connection.	If you use FTP communications with an FTP server over the Internet, make sure that the FTP open mode is not set to active.
16#000001AA	The connection was closed. Data transfer was aborted.	Check the connection to the FTP server. Make sure that the FTP server is operating.
16#000001C2	It was not possible to perform the requested file operation. Using the file was not possible, e.g., it is already open.	Make sure that the file is not open for any other application.
16#00000212	User login was not possible.	Check the FTP user name and password.
16#00000214	An account to save files is required.	Check the FTP user access rights.
16#00000226	Execution of the requested file operation was not possible because using the file was not possible, e.g., accessing it was not possible because it was not found.	Make sure that a file with the specified name exists in the directory on the FTP server. Check the access rights of the specified file.
16#00000229	Execution was not possible because the file name was not correct.	Check the access rights of the specified directory.



Version Information

A CPU Unit with unit version 1.08 or later and Sysmac Studio version 1.09 or higher are required to use this instruction.

Sample Programming

Refer to the sample programming for the FTPRemoveFile instruction (page 2-1172).

Serial Communications Instructions

Instruction	Name	Page
ExecPMCR	Protocol Macro	2-1188
SerialSend	SCU Send Serial	2-1201
SerialRcv and SerialRcvNoClear	SCU Receive Serial and SCU Receive Serial without Receive Buffer Clear	2-1212
SendCmd	Send Command	2-1227
NX_SerialSend	Send No-protocol Data	2-1240
NX_SerialRcv	Receive No-protocol Data	2-1253
NX_ModbusRtuCmd	Send Modbus RTU General Com- mand	2-1267
NX_ModbusRtuRead	Send Modbus RTU Read Com- mand	2-1277
NX_ModbusRtuWrite	Send Modbus RTU Write Com- mand	2-1288
NX_SerialSigCtl	Serial Control Signal ON/OFF Switching	2-1299
NX_SerialSigRead	Read Serial Control Signal	2-1308
NX_SerialStatusRead	Read Serial Port Status	2-1313
NX_SerialBufClear	Clear Buffer	2-1318
NX_SerialStartMon	Start Serial Line Monitoring	2-1328
NX_SerialStopMon	Stop Serial Line Monitoring	2-1333

ExecPMCR

The ExecPMCR instruction requests execution of a communications sequence (protocol data) registered in a Serial Communications Unit.

Instruction	Name	FB/ FUN	Graphic expression	ST expression
ExecPMCR	Protocol Macro	FB		ExecPMCR_instance(Execute, Port, SeqNo, SrcDat, DstDat, Done, Busy, Error, ErrorID, ErrorIDEx);



Precautions for Correct Use

You cannot use this instruction in an NX-series CPU Unit.

Variables

Name	Meaning	I/O	Description	Valid range	Unit	Default
Port	Destination port	Input	Destination port	---	---	---
SeqNo	Communications sequence number		Communications sequence number	0 to 999		0
SrcDat[] (array)	Send data array		Send data array	Depends on data type.		*
DstDat[] (array)	Receive data array	In-out	Receive data array	Depends on data type.	---	---

* If you omit the input parameter, the default value is not applied. A building error will occur.

	Boolean	Bit strings					Integers							Real numbers		Times, durations, dates, and text strings				
	BOOL	BYTE	WORD	DWORD	LWORD	USINT	UINT	UDINT	ULINT	SINT	INT	DINT	LINT	REAL	LREAL	TIME	DATE	TOD	DT	STRING
Port		Refer to <i>Function</i> for details on the structure <code>_sPORT</code> .																		
SeqNo							OK													
SrcDat[] (array)			OK																	
DstDat[] (array)			OK																	

Function

The ExecPMCR instruction requests execution of the sequence that is specified with communications sequence number *SeqNo* from the specified destination port *Port*.

If data is sent, it is sent from the second element (*SrcDat[1]*) of send data array *SrcDat[]*. The number of array elements to send is specified in *SrcDat[0]*.

If data is received successfully, the receive data is stored from the second element (*DstDat[1]*) of receive data array *DstDat[]*. The number of receive data elements is stored in *DstDat[0]*.

If data is not received successfully, the contents of *DstDat[]* from before instruction execution is retained for the number of elements specified in *DstDat[0]*.

The data type of destination port *Port* is the structure `_sPORT`. The specifications are as follows:

Name	Meaning	Description	Data type	Valid range	Unit	Default
Port	Destination port	Destination port	<code>_sPORT</code>	---	---	---
UnitNo	Unit number	Unit number of Serial Communications Unit	<code>_eUnitNo</code>	<code>_CBU_No00</code> to <code>_CBU_No15</code>	---	<code>_CBU_No00</code>
PhysicPortNo	Serial port number	Serial port number on Serial Communications Unit	USINT	1 or 2	---	1

The following figure shows a timing chart. Communications is performed to the end after the value of *Done* changes to TRUE.

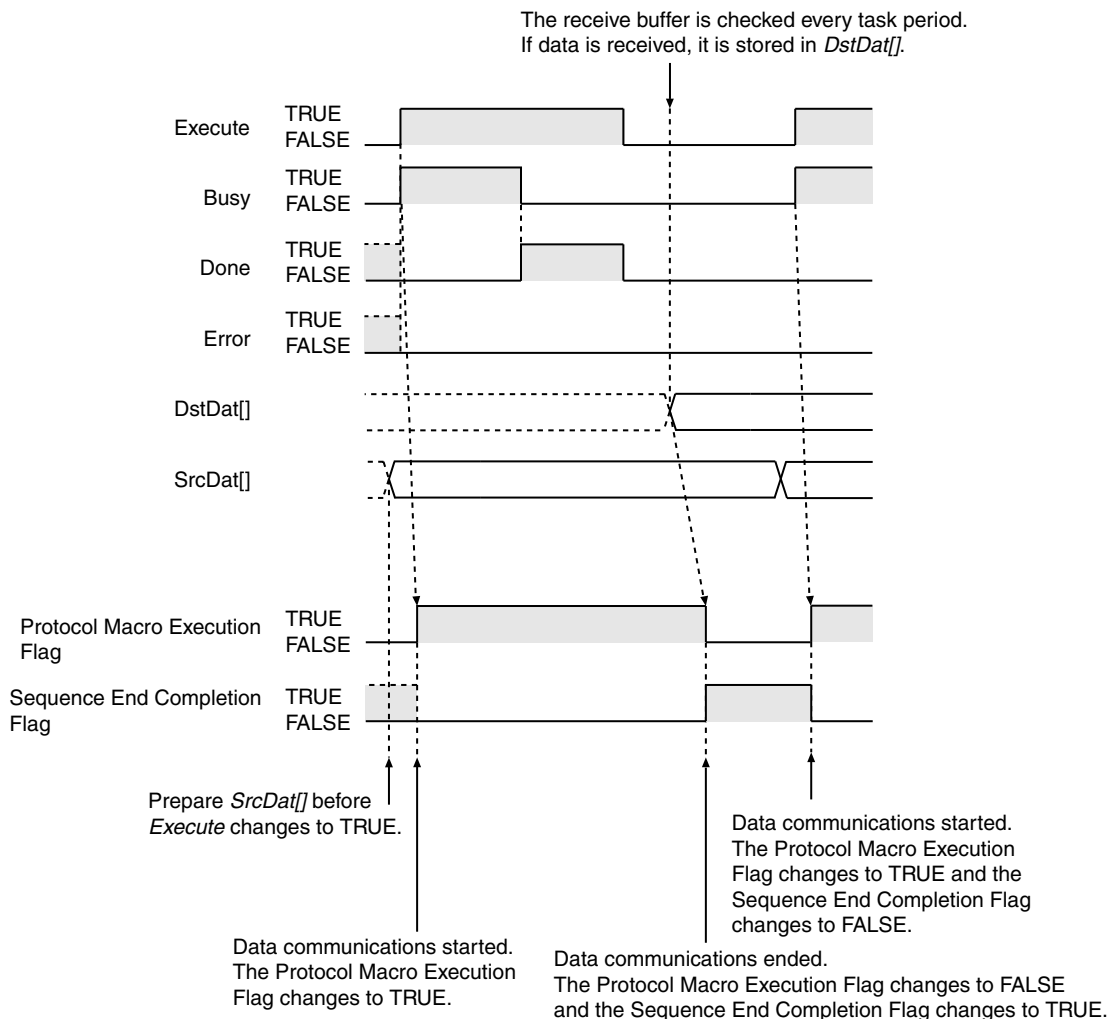

Related System-defined Variables

Name	Meaning	Data type	Description
_Port_numUsingPort	Number of Used Ports	USINT	This is the number of ports that are currently used.
_Port_isAvailable	Network Communications Instruction Enabled Flag	BOOL	TRUE: A port is available. FALSE: A port is not available.
_CJB_SCU##P1ChgSta, _CJB_SCU##P2ChgSta*	Serial Communications Unit ## Port 1/2 Settings Changing Flag	BOOL	TRUE: The serial port settings are currently being changed. FALSE: The serial port settings are currently not being changed.

* "##" denotes the unit number on the Serial Communications Unit.

Related Semi-user-defined Variables

Name	Meaning	Data type	Description
P#_PmrExecSta*	Protocol Macro Execution Flag	BOOL	TRUE: Protocol macro execution is in progress. FALSE: Protocol macro execution is not in progress or failed.
P#_PmrSeqEndSta*	Sequence End Completion Flag	BOOL	TRUE: The sequence was completed with an End. FALSE: The sequence was not completed with an End.
P#_PmrSeqAbtSta*	Sequence Abort Completion Flag	BOOL	TRUE: The sequence was completed with an Abort. FALSE: The sequence was not completed with an Abort.

* "#" denotes the port number on the Serial Communications Unit.

Additional Information

Refer to the *SYSMAC CX-Protocol Operation Manual* (Cat. No. W344) for details on protocol macros.

Precautions for Correct Use

- The ExecPMCR instruction starts execution of a protocol macro. Use the *P#PmrExecSta* (Protocol Macro Execution Flag) system-defined variable to check the status of protocol macro execution.
- Execution of this instruction is continued until processing is completed even if the value of *Execute* changes to FALSE or the execution time exceeds the task period. The value of *Done* changes to TRUE when processing is completed. Use this to confirm normal completion of processing.
- Refer to *Using this Section* on page 2-3 for a timing chart for *Execute*, *Done*, *Busy*, and *Error*.
- An address in memory for CJ-series Units must be specified in the AT Specification attribute of *DstDat[]*.
- Set the value of *SrcDat[0]* and *DstDat[0]* to 0 to use a direct specification and link word specification. An error occurs if you set any other constant or variable, and the instruction is not executed.
- If the value of *DstDat[0]* is 0 or 1 and reception fails, all elements in *DstDat[]* change to 0.
- The instruction is executed only when there is an available port. Therefore, use the system-defined variable *_Port_isAvailable* (Network Communications Instruction Enabled Flag) in an N.O. execution condition for the instruction.
- The instruction is not executed while *Busy* is TRUE. Therefore, use *Busy* in an N.C. execution condition for the instruction.

- The Protocol Macro Execution Flag (semi-user-defined variable *P#_PmrExecSta*) changes to TRUE when instruction execution is started. It changes to FALSE after the communications sequence is completed and the receive data is stored in *DstDat[]*. You cannot execute this instruction for the same serial port while *P#_PmrExecSta* is TRUE. Therefore, use *P#_PmrExecSta* in an N.C. execution condition for the instruction.
- If the instruction is used in ST, make sure that the instruction is processed each task period as long as instruction execution continues. Otherwise, normal processing is sometimes not possible.
- An error occurs in the following cases. *Error* will change to TRUE.
 - The serial communications mode is not set to Protocol Macro Mode when the instruction is executed.
 - The value of *_Port_isAvailable* is FALSE.
 - The value of *SeqNo* is outside of the valid range.
 - The value of *SeqNo* is not registered to a Serial Communications Unit.
 - The value of *Port.UnitNo* or *Port.PhysicPortNo* is outside of the valid range.
 - There is no CJ-series Serial Communications Unit with the specified unit number.
 - The value of *SrcDat[0]* exceeds the size of *SrcDat[]*.
 - The value of *DstDat[0]* exceeds the size of *DstDat[]*.
 - The value of *SrcDat[0]* or *DstDat[0]* exceeds 250 words.
 - Communications fail.
 - An address in memory for CJ-series Units is not specified in the AT Specification attribute of *Dst-Dat[]*.
- For this instruction, expansion error code *ErrorIDEx* gives the communications response code. The values and meanings are listed in the following table. An expansion error code is output to *ErrorIDEx* when the value of error code *ErrorID* is WORD#16#0800.

Value	Error	Correction
16#00000001	The communications service was interrupted.	<ul style="list-style-type: none"> • Check the data link execution status. • Check the capacity of the transfer destination area on the third node.
16#00000101	The local node is not part of the network.	Make the local node part of the network.
16#00000102	A token timeout occurred.	Set the local node address to within the maximum node address.
16#00000103	The retry count was exceeded.	Perform internode tests. If communications is not normal, check the operating environment.
16#00000104	The allowable number of send frames was exceeded.	Check the status of events in the network and reduce the number of events in each task period. Or, increase the number of allowable send frames.
16#00000105	The IP address of the local node is out of range.	Set the rotary switches on the Serial Communications Unit correctly.
16#00000106	The IP address of the local node is also used by another node in the network.	Change one of the node addresses that are duplicated.
16#00000201	The remote node is not part of the network.	Make the remote node part of the network.
16#00000202	A Unit with the specified unit address does not exist at the destination.	Correctly set the unit address for the destination network address.
16#00000203	The third node is not part of the network.	<ul style="list-style-type: none"> • Check the address of the Unit that is the third node. • Specify only one node for the third node.
16#00000204	The remote node is busy.	Increase the setting of the number of retries or correct the system so that communications traffic is not concentrated on the remote node.
16#00000205	A response timeout occurred.	Check the settings of the communications parameters.
16#00000206	There is an error in the transmission path.	<ul style="list-style-type: none"> • Attempt retries. • If this error occurs frequently, check for noise.

Value	Error	Correction
16#00000301	A Communications Controller Error occurred.	Refer to the operation manual for the relevant Unit and make suitable corrections.
16#00000302	There is an error in the CPU Unit at the remote node.	Refer to the manual for the CPU Unit at the remote node and remove the error.
16#00000303	There is an error in the relevant Controller and a response is not returned.	Check the communications status on the network and restart the relevant Controller. If the error still occurs, replace the relevant Controller.
16#00000304	The unit number setting is not correct.	Set the rotary switches on the Serial Communications Unit correctly.
16#00000401	The command that was sent is not supported.	Set the command array correctly.
16#00000402	The Unit model or version is not supported.	Check the Unit model and version.
16#00000501	The remote address setting is wrong.	Set the destination address in the routing tables.
16#00000502	Routing tables are not registered.	Set the source node, destination node, and relay nodes in the routing tables.
16#00000503	There is an error in the routing tables.	Correct the settings in the routing tables.
16#00000504	There are too many relay points.	Restructure the networks or correct the routing tables so that commands are used within a three-layer range.
16#00001001	The command is too long.	Set the command array correctly.
16#00001002	The command is too short.	Set the command array correctly.
16#00001003	The number of write elements that is specified in the command does not agree with the number of write data.	Specify the same number of write elements and write data.
16#00001004	The command format is incorrect.	Set the command array correctly.
16#00001005	There is an error in the header.	Correct the settings in the routing tables.
16#00001101	The area type does not exist.	Refer to the command variables and parameter type codes and set the relevant codes.
16#00001102	An access size is wrong.	Correctly set the variable and parameter access sizes.
16#00001103	An out-of-range address was specified.	Specify an address that is within the process range.
16#00001104	The address range was exceeded.	<ul style="list-style-type: none"> Specify an address that is within the process range. Correct the settings in the data link table.
16#00001106	A communications sequence number that is not registered was specified.	Correct the communications sequence number or add the sequence with the CX-Protocol.
16#00001109	An interrelationship error occurred.	<ul style="list-style-type: none"> Correct the size relationships in the command data. Correct the settings in the data link table.
16#0000110A	Data is redundant.	<ul style="list-style-type: none"> Cancel the current process or wait for it to be completed before you execute the command. Correct the settings in the data link table.
16#0000110B	The response is too long.	Set the number of elements in the command array correctly.
16#0000110C	This is another parameter error.	Set the command array correctly.
16#00002002	The data is protected.	Execute the command again after clearing the protection.
16#00002003	There is no registered table.	Set the table correctly.
16#00002004	There is no data that matches the search data.	Set the search data correctly.
16#00002005	The relevant program number does not exist.	Set a valid program number.
16#00002006	The relevant file does not exist.	Set the file name correctly, including the subdirectory names.

Value	Error	Correction
16#00002007	A verification error occurred.	<ul style="list-style-type: none"> • Check the contents of memory and write the correct data. • Check the contents of the file.
16#00002101	Access is not possible because the area is read-only.	Execute the command again after clearing the write protection.
16#00002102	The data is protected or the data link table cannot be written.	<ul style="list-style-type: none"> • Execute the command again after clearing the write protection. • Set the system settings in the data link table.
16#00002103	Registration is not possible.	<ul style="list-style-type: none"> • Create the file after deleting unnecessary files or prepare new file memory. • Execute the command again after closing open files.
16#00002105	The relevant program number does not exist.	Set a valid program number.
16#00002106	The relevant file does not exist.	Set the file name correctly, including the subdirectory names.
16#00002107	A file with the same name already exists.	Execute the command again after changing the name of the file to write.
16#00002108	The change is not possible because an error occurred when trying to make it.	Correct the settings.
16#00002201	The operation was not possible because a protocol macros is already in execution.	Use an N.C. program input for the Protocol Macro Execution Flag.
16#00002202	The operating mode is wrong.	Check the operating mode.
16#00002203	The operating mode is wrong for the instruction (PROGRAM mode).	Check the operating mode of the Controller.
16#00002204	The operating mode is wrong for the instruction (DEBUG mode).	Check the operating mode of the Controller.
16#00002205	The operating mode is wrong for the instruction (MONITOR mode).	Check the operating mode of the Controller.
16#00002206	The operating mode is wrong for the instruction (RUN mode).	Check the operating mode of the Controller.
16#00002207	The specified mode is not the polling node.	Confirm which node is the polling node of the network.
16#00002208	The operating mode is wrong for the instruction.	Check step activation status.
16#00002211	The Unit is busy.	Increase the setting of the number of retries or correct the system so that communications traffic is not concentrated on the relevant Unit.
16#00002301	The file device does not exist.	Insert the media. Or, format the EM.
16#00002302	There is no file memory.	Check the file memory device.
16#00002303	There is no built-in clock.	Check the specifications of the model.
16#00002401	A checksum error occurred in the protocol macro data or the data transfer is not yet completed.	Transfer the protocol macro data from the CX-Protocol again.
16#00002502	There is an error in the part of memory for processing.	Transfer the correct data to memory.
16#00002503	The registered I/O Unit configuration does not agree with the physical Unit configuration.	Check the I/O Unit configuration.
16#00002504	There are too many local or remote I/O points.	Set the number of local and remote I/O points correctly.
16#00002505	An error occurred in a data transmission between the CPU Unit and a CPU Bus Unit.	Check the Units and the connecting cables. After removing the error, execute a command to reset the error.
16#00002506	The same rack number, unit number, or I/O address is set more than once.	Correct the settings so that each number is unique.
16#00002507	An error occurred in a data transmission between the CPU Unit and an I/O Unit.	Check the Units and connecting cables. After removing the error, execute a command to reset the error.

Value	Error	Correction
16#00002509	There is an error in SYSMAC BUS/2 data transmission.	Check the Units and connecting cables. After removing the error, execute a command to reset the error.
16#0000250A	An error occurred in a CPU Bus Unit data transmission.	Check the Units and connecting cables. After removing the error, execute a command to reset the error.
16#0000250D	The same word setting is used more than once.	Set the I/O words correctly.
16#0000250F	There is an error in memory.	<ul style="list-style-type: none"> For internal memory, execute the command again after writing the correct data. For a Memory Card or EM file memory, execute the expansion memory format command. If the error cannot be reset with the above corrections, replace the memory.
16#00002510	The end station setting is wrong.	Set the end station correctly.
16#00002601	Protection is already cleared.	You do not need to clear protection.
16#00002602	The password was wrong.	Specify the correct password.
16#00002604	The data is protected.	<ul style="list-style-type: none"> Execute the command again after clearing the write protection. Wait for the service that is currently in execution to end or stop the service, and then execute the command again.
16#00002605	The service is busy.	Wait for the service that is currently in execution to end or stop the service, and then execute the command again.
16#00002606	The service is stopped.	Execute the relevant service as required.
16#00002607	You do not have the execution right.	<ul style="list-style-type: none"> Execute the operation from the node that accessed the data link. If the error still occurs after restarting, replace the Controller.
16#00002608	The environment is not set.	Make the necessary settings.
16#00002609	The required items are not set.	Set the required items.
16#0000260A	The specified number is already defined.	Execute the command again after changing the specified number to an action or transition number that is not already registered.
16#0000260B	The error cannot be reset.	Remove the cause of the error and then execute the error reset command.
16#00003001	You do not have access rights.	Wait for the access right to be cleared and then execute the command again.
16#00004001	The service was interrupted.	Execute the command again after clearing the cause of the service interruption.

Note In addition to the codes in the above table, the values of bits 6, 7, and 15 in the end code can be TRUE. If the value of bit 6 or 7 is TRUE, there is an error in the CPU Unit at the destination. If the value of bit 15 is TRUE, an error occurred during a network relay.

Sample Programming

In this sample, a CJ-series Serial Communications Unit is used for data communications with an OMRON Temperature Controller. The present value of the Temperature Controller is read with a protocol macro. CompoWay/F master sequence 610 (Read Variable Area) is used. The contents of send data array *SendData[]* is sent from the Controller. The data received from the Temperature Controller is stored in receive data array *RecvData[]*.

The following communications specifications are used.

Item	Description
Unit used	Serial Communications Unit
Unit number	2
Port number	1 (RS-422/485)
Communications sequence number	610 (Read Variable Area)
Remote node number	3
Data to read	Present value

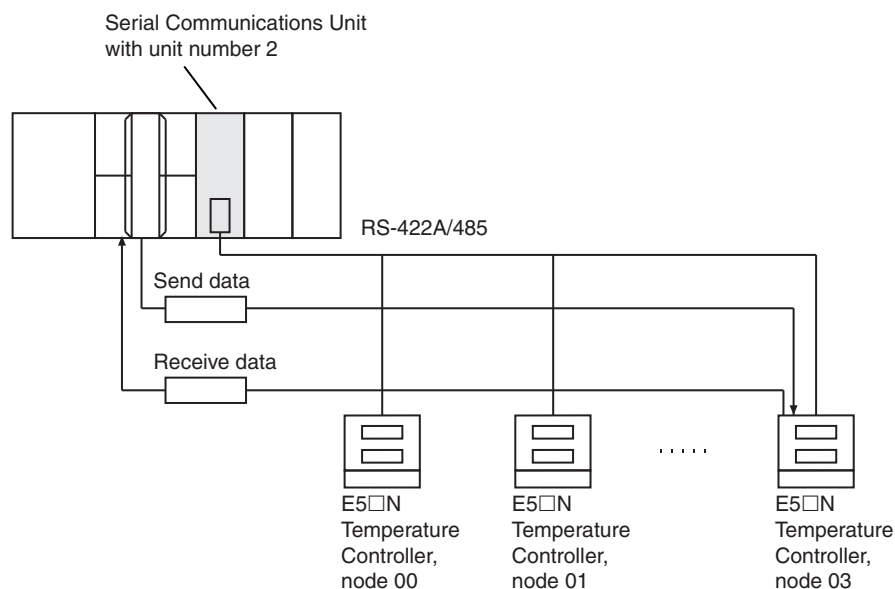

The communications data for sequence 610 (Read Variable Area) is allocated as shown below.

Send Data: WORD Array

SendData[0]	Number of send data words
SendData[1]	Not used. Node No.
SendData[2]	Variable type
SendData[3]	Read start address
SendData[4]	Number of elements

Receive Data: WORD Array

RecvData[0]	Number of receive data words
RecvData[1]	Response code
RecvData[2]	Receive data
RecvData[3]	

The contents of send data *SendData[]* and receive data *RecvData[]* are as follows:

Send Data: WORD Array

Variable	Item	Contents	Value
SendData[0]	Number of send data words	Five words from <i>SendData[0]</i> to <i>SendData[4]</i> are sent.	WORD#16#0005
SendData[1]	Node number	Node 3 is used.	WORD#16#0003
SendData[2]	Variable type + Upper byte of read start address	To read the present value, the variable type is BYTE#16#C0 and the read start address is WORD#16#00.	WORD#16#C000
SendData[3]	Lower byte of read start address + BYTE#16#00 (fixed value)		WORD#16#0000
SendData[4]	Number of elements	One element is read.	WORD#16#0001

Receive Data: WORD Array

Variable	Item	Contents	Value
RecvData[0]	Number of receive data words	Four words from <i>RecvData[0]</i> to <i>RecvData[3]</i> are received.	WORD#16#0004
RecvData[1]	Response code	WORD#16#0000 is returned for a normal end.	
RecvData[2]	Receive data	The lower two bytes of the present value of the Temperature Controller are returned.	
RecvData[3]		The upper two bytes of the present value of the Temperature Controller are returned.	

If the data is received successfully, the lower two bytes (*RecvData[2]*) and the upper two bytes (*RecvData[3]*) of the present value of the Temperature Controller are assigned to *TmpData*.

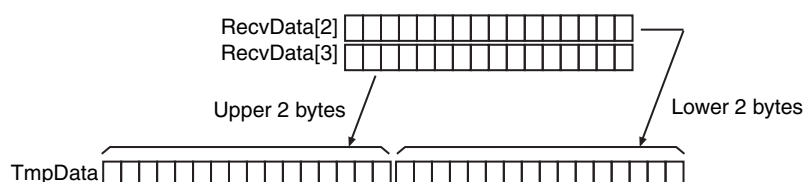

Definitions of Global Variables

Global Variables

Name	Data type	AT ^{*1}	Comment
SCU_P1_PmrSeqEndSta	BOOL	IOBus://rack#0/slot#0/P1_PmrSta/P1_PmrSeqEndSta	Sequence End Completion Flag
SCU_P1_PmrSeqAbtSta	BOOL	IOBus://rack#0/slot#0/P1_PmrSta/P1_PmrSeqAbtSta	Sequence Abort Completion Flag
SCU_P1_PmrExecSta	BOOL	IOBus://rack#0/slot#0/P1_PmrSta/P1_PmrExecSta	Protocol Macro Execution Flag

*1 AT when the Serial Communications Unit is mounted to slot number 0 in rack number 0

LD

Internal Variables	Variable	Data type	Initial value	AT	Retain	Comment
	OperatingEnd	BOOL	FALSE			Processing completed
	Trigger	BOOL	FALSE			Execution condition
	Operating	BOOL	FALSE			Processing
	InPort	_sPORT	(UnitNo:=_CBU_No00, PhysicPortNo:=0)			Port settings
	SendData	ARRAY[0..4] OF WORD	[5(16#0)]			Send data
	RecvData	ARRAY[0..3] OF WORD	[4(16#0)]	%D200	✓	Receive data
	TmpData	DINT	0			Present value
	RS_instance	RS				
	ExecPMCR_instance	ExecPMCR				

External Variables	Variable	Data type	Comment
	SCU_P1_PmrSeqEndSta	BOOL	Sequence End Completion Flag
	SCU_P1_PmrSeqAbtSta	BOOL	Sequence Abort Completion Flag
	SCU_P1_PmrExecSta	BOOL	Protocol Macro Execution Flag
	_Port_isAvailable	BOOL	Network Communications Instruction Enabled Flag

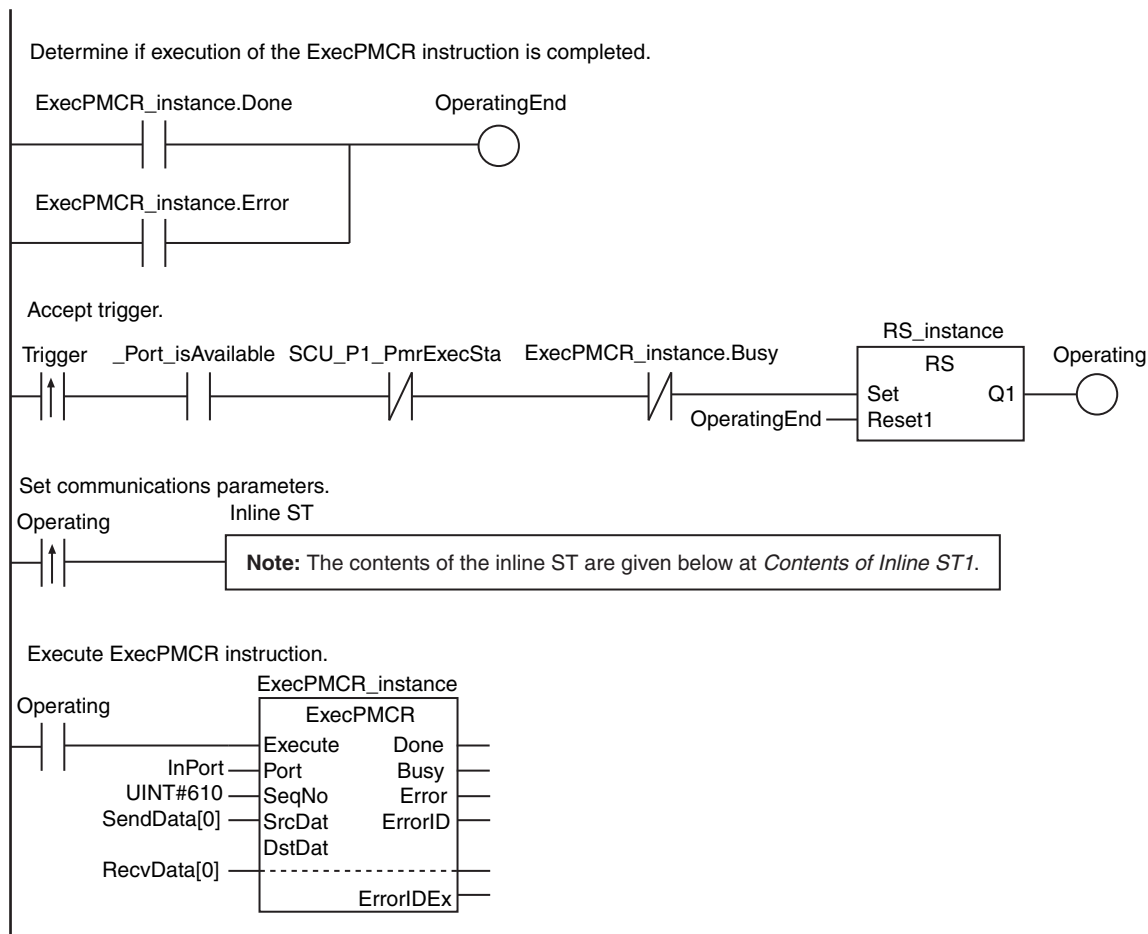

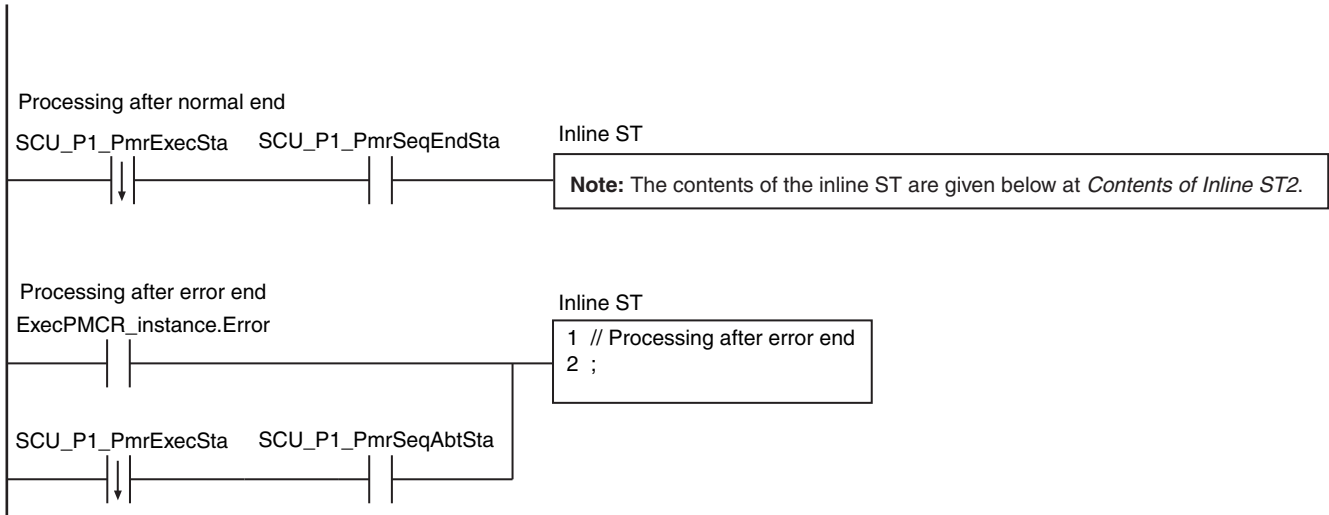

Contents of Inline ST1

```
InPort.UnitNo      :=_CBU_No02; // Serial Communications Unit with unit number 2
InPort.PhysicPortNo:=USINT#1;  // Port number 1
SendData[0]       :=WORD#16#0005;
SendData[1]       :=WORD#16#0003;
SendData[2]       :=WORD#16#C000;
SendData[3]       :=WORD#16#0000;
SendData[4]       :=WORD#16#0001;
RecvData[0]       :=WORD#16#0004;
```

Contents of Inline ST2

```
// Processing after normal end
TmpData:=DWORD_TO_DINT(SHL(WORD_TO_DWORD(
    RecvData[3]), 16) OR WORD_TO_DWORD(RecvData[2]));
```

ST

Internal Variables	Variable	Data type	Initial value	AT	Retain	Comment
	State	INT	0			Current state
	Trigger	BOOL	FALSE			Execution condition
	LastTrigger	BOOL	FALSE			Value of <i>Trigger</i> from previous task period
	InPort	_sPORT	(UnitNo:=_CBU_No00, PhysicPortNo:=0)			Port settings
	SendData	ARRAY[0..4] OF WORD	[5(16#0)]			Send data
	RecvData	ARRAY[0..3] OF WORD	[4(16#0)]	%D200	✓	Receive data
	End_ExecPMCR	BOOL	FALSE			Completion of ExecPMCR instruction execution
	TmpData	DINT	0			Present value
	RS_instance	RS				
	ExecPMCR_instance	ExecPMCR				
	F_TRIG_instance	F_TRIG				

External Variables	Variable	Data type	Comment
	SCU_P1_PmrSeqEndSta	BOOL	Sequence End Completion Flag
	SCU_P1_PmrSeqAbtSta	BOOL	Sequence Abort Completion Flag
	SCU_P1_PmrExecSta	BOOL	Protocol Macro Execution Flag
	_Port_isAvailable	BOOL	Network Communications Instruction Enabled Flag

```

// Accept trigger.
IF (State=INT#0) THEN
  IF ( (Trigger=TRUE) AND (LastTrigger=FALSE) AND (_Port_isAvailable=TRUE) AND (SCU_P1_PmrExecSta<>TRUE)
    AND (ExecPMCR_instance.Busy<>TRUE) ) THEN
    State:=INT#1;
  END_IF;
END_IF;
LastTrigger:=Trigger;

// Set communications parameters and initialize ExecPMCR instruction.
IF (State=INT#1) THEN
  InPort.UnitNo      :=_CBU_No02; // Serial Communications Unit with unit number 2
  InPort.PhysicPortNo :=USINT#1;  // Port number 1
  SendData[0]       :=WORD#16#0005;
  SendData[1]       :=WORD#16#0003;
  SendData[2]       :=WORD#16#C000;
  SendData[3]       :=WORD#16#0000;
  SendData[4]       :=WORD#16#0001;
  RecvData[0]       :=WORD#16#0004;
  ExecPMCR_instance(
    Execute :=FALSE, // Initialize ExecPMCR instruction.
    SrcDat  :=SendData[0], // Dummy
    DstDat  :=RecvData[0]);
  State:=INT#2;
END_IF;

// Execute ExecPMCR instruction.
IF (State=INT#2) THEN
  ExecPMCR_instance(
    Execute :=TRUE,

```

```
    Port    :=InPort,
    SeqNo   :=UINT#610,
    SrcDat  :=SendData[0],
    DstDat  :=RecvData[0]);

F_TRIG_instance(SCU_P1_PmrExecSta, End_ExecPMCR);

IF (End_ExecPMCR=TRUE) THEN
    End_ExecPMCR:=FALSE;
    State:=INT#3;
END_IF;

IF (ExecPMCR_instance.Error=TRUE) THEN
    State:=INT#5;
END_IF;

END_IF;

// Confirm completion of ExecPMCR instruction execution.
IF (State=INT#3) THEN
    IF (SCU_P1_PmrSeqEndSta=TRUE) THEN
        State:=INT#4;
    END_IF;
    IF (SCU_P1_PmrSeqAbtSta=TRUE) THEN
        State:=INT#5;
    END_IF;
END_IF;

IF (State=INT#4) THEN
    // Processing after normal end.
    TmpData:=DWORD_TO_DINT(SHL(WORD_TO_DWORD(RecvData[3]), 16)
        OR WORD_TO_DWORD(RecvData[2]));
    State:=INT#0;
END_IF;

IF (State=INT#5) THEN
    // Processing after error end
    State:=INT#0;
END_IF;
```

SerialSend

The SerialSend instruction sends data in No-protocol Mode from a serial port on a Serial Communications Unit.

Instruction	Name	FB/ FUN	Graphic expression	ST expression
SerialSend	SCU Send Serial	FB	<pre> SerialSend_instance SerialSend - Execute Done - Port Busy - SrcDat Error - SendSize ErrorID ErrorIDEx </pre>	SerialSend_instance(Execute, Port, SrcDat, SendSize, Done, Busy, Error, ErrorID, ErrorIDEx);



Precautions for Correct Use

You cannot use this instruction in an NX-series CPU Unit.

Variables

Name	Meaning	I/O	Description	Valid range	Unit	Default
Port	Destination port	Input	Destination port	---	---	---
SrcDat[] (array)	Send data array		Send data array	Depends on data type.		*
SendSize	Send data size		Data size to send from <i>SrcDat[]</i>	0 to 256	Bytes	1

* If you omit an input parameter, the default value is not applied. A building error will occur.

	Boolean	Bit strings				Integers							Real numbers		Times, durations, dates, and text strings						
	BOOL	BYTE	WORD	DWORD	LWORD	USINT	UINT	UDINT	ULINT	SINT	INT	DINT	LINT	REAL	LREAL	TIME	DATE	TOD	DT	STRING	
Port																					
SrcDat[] (array)		OK																			
SendSize							OK														

Function

The SerialSend instruction sends data in No-protocol Mode from the port and the Serial Communications Unit specified with *Port*.

The data that is sent is contained in send data array *SrcDat[]*. The data size to send is specified in send data size *SendSize*.

To attach start and end codes to the send data, set them in the DM Area words that are assigned to the Special Unit.

If you add start and end codes, the maximum number of bytes to send is 259 (1-byte start code, 2-byte end code (for CR+LF specification), and 256 bytes of send data).

The data type of destination port *Port* is the structure *_sPORT*. The specifications are as follows:

Name	Meaning	Description	Data type	Valid range	Unit	Default
Port	Destination port	Destination port	_sPORT	---	---	---
UnitNo	Unit number	Unit number of Serial Communications Unit	_eUnitNo	_CBU_No00 to _CBU_No15		_CBU_No00
PhysicPortNo	Serial port number	Serial port number on Serial Communications Unit	USINT	1 or 2	---	1

The following figure shows a timing chart. Communications is performed to the end after the value of *Done* changes to TRUE.

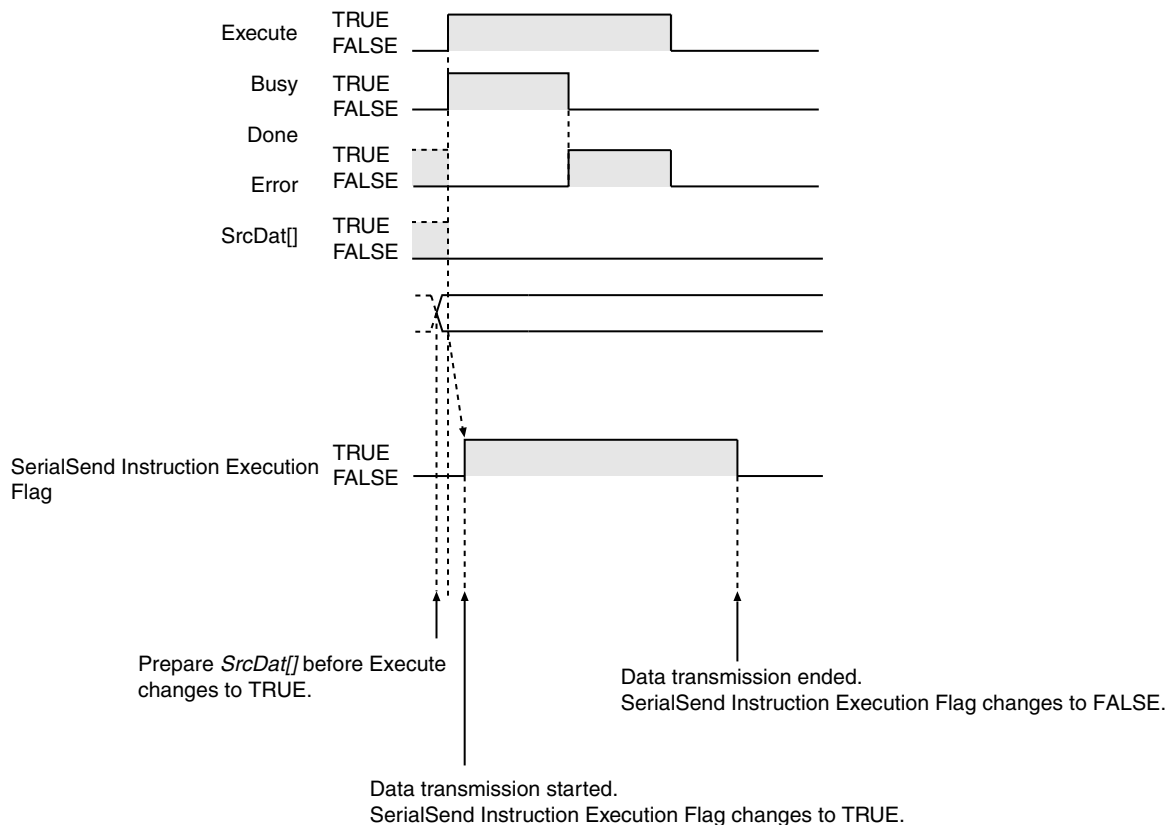

Related System-defined Variables

Name	Meaning	Data type	Description
<code>_Port_numUsingPort</code>	Number of Used Ports	USINT	This is the number of ports that are currently used.
<code>_Port_isAvailable</code>	Network Communications Instruction Enabled Flag	BOOL	TRUE: A port is available. FALSE: A port is not available.

Related Semi-user-defined Variables

Name	Meaning	Data type	Description
<code>P#_NopSerialSendExecSta*</code>	SerialSend Instruction Execution Flag	BOOL	TRUE: Execution of the SerialSend instruction is in progress. FALSE: Execution of the SerialSend instruction is not in progress.
<code>P#_NopStartCodeYNCfg*</code>	No-protocol Start Code Enable	BOOL	TRUE: Start code FALSE: No start code
<code>P#_NopEndCodeYNCfg*</code>	No-protocol End Code Enable	BOOL	TRUE: End code FALSE: No end code
<code>P#_NopCRLFcfg*</code>	No-protocol CR LF Specification	BOOL	TRUE: CR+LF FALSE: No CR+LF
<code>P#_NopStartCodeCfg*</code>	No-protocol Start Code	USINT	16#00 to 16#FF
<code>P#_NopEndCodeCfg*</code>	No-protocol End Code	USINT	16#00 to 16#FF

* “#” denotes the port number on the Serial Communications Unit.

Additional Information

Refer to the following manual for details on no-protocol communications.

- *CJ-series Serial Communications Units Operation Manual for NJ-series CPU Unit (Cat. No. W494)*

Precautions for Correct Use

- Execution of this instruction is continued until processing is completed even if the value of *Execute* changes to FALSE or the execution time exceeds the task period. The value of *Done* changes to TRUE when processing is completed. Use this to confirm normal completion of processing.
- Refer to *Using this Section* on page 2-3 for a timing chart for *Execute*, *Done*, *Busy*, and *Error*.
- You can use this instruction only for a Serial Communications Unit's serial port that is set to No-protocol Mode.
- Nothing is sent if the value of *SendSize* is 0. When the instruction is executed, the value of *Done* changes to TRUE.
- Even when attaching a start or end code, do not include it in the value of *SendSize*.
- The instruction is executed only when there is an available port. Therefore, use the system-defined variable `_Port_isAvailable` (Network Communications Instruction Enabled Flag) in an N.O. execution condition for the instruction.
- The instruction is not executed while *Busy* is TRUE. Therefore, use *Busy* in an N.C. execution condition for the instruction.
- You cannot execute this instruction while the SerialSend Instruction Executing Flag (semi-user-defined variable `P#NopSerialSendExecSta`) is TRUE. Use `P#NopSerialSendExecSta` in an N.C. execution condition for the instruction.
- If the instruction is used in ST, make sure that the instruction is processed each task period as long as instruction execution continues. Otherwise, normal processing is sometimes not possible.

- An error occurs in the following cases. *Error* will change to TRUE.
 - The serial communications mode is not set to No-protocol Mode when the instruction is executed.
 - The value of *_Port_isAvailable* is FALSE.
 - The value of *Port.UnitNo* or *Port.PhysicPortNo* is outside of the valid range.
 - There is no CJ-series Serial Communications Unit with the specified unit number.
 - The value of *SendSize* is outside of the valid range.
 - The value of *SendSize* exceeds the size of *SrcDat[]*.
 - Communications fail.
 - The instruction is executed during a Unit restart.
- For this instruction, expansion error code *ErrorIDEx* gives the communications response code. The values and meanings are listed in the following table. An expansion error code is output to *ErrorIDEx* when the value of error code *ErrorID* is WORD#16#0800.

Value	Error	Correction
16#00000001	The communications service was interrupted.	<ul style="list-style-type: none"> • Check the data link execution status. • Check the capacity of the transfer destination area on the third node.
16#00000101	The local node is not part of the network.	Make the local node part of the network.
16#00000102	A token timeout occurred.	Set the local node address to within the maximum node address.
16#00000103	The retry count was exceeded.	Perform internode tests. If communications is not normal, check the operating environment.
16#00000104	The allowable number of send frames was exceeded.	Check the status of events in the network and reduce the number of events in each task period. Or, increase the number of allowable send frames.
16#00000105	The IP address of the local node is out of range.	Set the rotary switches on the Serial Communications Unit correctly.
16#00000106	The IP address of the local node is also used by another node in the network.	Change one of the node addresses that are duplicated.
16#00000201	The remote node is not part of the network.	Make the remote node part of the network.
16#00000202	A Unit with the specified unit address does not exist at the destination.	Correctly set the unit address for the destination network address.
16#00000203	The third node is not part of the network.	<ul style="list-style-type: none"> • Check the address of the Unit that is the third node. • Specify only one node for the third node.
16#00000204	The remote node is busy.	Increase the setting of the number of retries or correct the system so that communications traffic is not concentrated on the remote node.
16#00000205	A response timeout occurred.	Check the settings of the communications parameters.
16#00000206	There is an error in the transmission path.	<ul style="list-style-type: none"> • Attempt retries. • If this error occurs frequently, check for noise.
16#00000301	A Communications Controller Error occurred.	Refer to the operation manual for the relevant Unit and make suitable corrections.
16#00000302	There is an error in the CPU Unit at the remote node.	Refer to the manual for the CPU Unit at the remote node and remove the error.
16#00000303	There is an error in the relevant Controller and a response is not returned.	Check the communications status on the network and restart the relevant Controller. If the error still occurs, replace the relevant Controller.
16#00000304	The unit number setting is not correct.	Set the rotary switches on the Serial Communications Unit correctly.
16#00000401	The command that was sent is not supported.	Set the command array correctly.
16#00000402	The Unit model or version is not supported.	Check the Unit model and version.

Value	Error	Correction
16#00000501	The remote address setting is wrong.	Set the destination address in the routing tables.
16#00000502	Routing tables are not registered.	Set the source node, destination node, and relay nodes in the routing tables.
16#00000503	There is an error in the routing tables.	Correct the settings in the routing tables.
16#00000504	There are too many relay points.	Restructure the networks or correct the routing tables so that commands are used within a three-layer range.
16#00001001	The command is too long.	Set the command array correctly.
16#00001002	The command is too short.	Set the command array correctly.
16#00001003	The number of write elements that is specified in the command does not agree with the number of write data.	Specify the same number of write elements and write data.
16#00001004	The command format is incorrect.	Set the command array correctly.
16#00001005	There is an error in the header.	Correct the settings in the routing tables.
16#00001101	The area type does not exist.	Refer to the command variables and parameter type codes and set the relevant codes.
16#00001102	An access size is wrong.	Correctly set the variable and parameter access sizes.
16#00001103	An out-of-range address was specified.	Specify an address that is within the process range.
16#00001104	The address range was exceeded.	<ul style="list-style-type: none"> Specify an address that is within the process range. Correct the settings in the data link table.
16#00001106	A communications sequence number that is not registered was specified.	Correct the communications sequence number or add the sequence with the CX-Protocol.
16#00001109	An interrelationship error occurred.	<ul style="list-style-type: none"> Correct the size relationships in the command data. Correct the settings in the data link table.
16#0000110A	Data is redundant.	<ul style="list-style-type: none"> Cancel the current process or wait for it to be completed before you execute the command. Correct the settings in the data link table.
16#0000110B	The response is too long.	Set the number of elements in the command array correctly.
16#0000110C	This is another parameter error.	Set the command array correctly.
16#00002002	The data is protected.	Execute the command again after clearing the protection.
16#00002003	There is no registered table.	Set the table correctly.
16#00002004	There is no data that matches the search data.	Set the search data correctly.
16#00002005	The relevant program number does not exist.	Set a valid program number.
16#00002006	The relevant file does not exist.	Set the file name correctly, including the subdirectory names.
16#00002007	A verification error occurred.	<ul style="list-style-type: none"> Check the contents of memory and write the correct data. Check the contents of the file.
16#00002101	Access is not possible because the area is read-only.	Execute the command again after clearing the write protection.
16#00002102	The data is protected or the data link table cannot be written.	<ul style="list-style-type: none"> Execute the command again after clearing the write protection. Set the system settings in the data link table.
16#00002103	Registration is not possible.	<ul style="list-style-type: none"> Create the file after deleting unnecessary files or prepare new file memory. Execute the command again after closing open files.
16#00002105	The relevant program number does not exist.	Set a valid program number.

Value	Error	Correction
16#00002106	The relevant file does not exist.	Set the file name correctly, including the subdirectory names.
16#00002107	A file with the same name already exists.	Execute the command again after changing the name of the file to write.
16#00002108	The change is not possible because an error occurred when trying to make it.	Correct the settings.
16#00002201	The operation was not possible because a protocol macros is already in execution.	Use an N.C. program input for the Protocol Macro Execution Flag.
16#00002202	The operating mode is wrong.	Check the operating mode.
16#00002203	The operating mode is wrong for the instruction (PROGRAM mode).	Check the operating mode of the Controller.
16#00002204	The operating mode is wrong for the instruction (DEBUG mode).	Check the operating mode of the Controller.
16#00002205	The operating mode is wrong for the instruction (MONITOR mode).	Check the operating mode of the Controller.
16#00002206	The operating mode is wrong for the instruction (RUN mode).	Check the operating mode of the Controller.
16#00002207	The specified mode is not the polling node.	Confirm which node is the polling node of the network.
16#00002208	The operating mode is wrong for the instruction.	Check step activation status.
16#00002211	The Unit is busy.	Increase the setting of the number of retries or correct the system so that communications traffic is not concentrated on the relevant Unit.
16#00002301	The file device does not exist.	Insert the media. Or, format the EM.
16#00002302	There is no file memory.	Check the file memory device.
16#00002303	There is no built-in clock.	Check the specifications of the model.
16#00002401	A checksum error occurred in the protocol macro data or the data transfer is not yet completed.	Transfer the protocol macro data from the CX-Protocol again.
16#00002502	There is an error in the part of memory for processing.	Transfer the correct data to memory.
16#00002503	The registered I/O Unit configuration does not agree with the physical Unit configuration.	Check the I/O Unit configuration.
16#00002504	There are too many local or remote I/O points.	Set the number of local and remote I/O points correctly.
16#00002505	An error occurred in a data transmission between the CPU Unit and a CPU Bus Unit.	Check the Units and the connecting cables. After removing the error, execute a command to reset the error.
16#00002506	The same rack number, unit number, or I/O address is set more than once.	Correct the settings so that each number is unique.
16#00002507	An error occurred in a data transmission between the CPU Unit and an I/O Unit.	Check the Units and the connecting cables. After removing the error, execute a command to reset the error.
16#00002509	There is an error in SYSMAC BUS/2 data transmission.	Check the Units and the connecting cables. After removing the error, execute a command to reset the error.
16#0000250A	An error occurred in a CPU Bus Unit data transmission.	Check the Units and the connecting cables. After removing the error, execute a command to reset the error.
16#0000250D	The same word setting is used more than once.	Set the I/O words correctly.

Value	Error	Correction
16#0000250F	There is an error in memory.	<ul style="list-style-type: none"> For internal memory, execute the command again after writing the correct data. For a Memory Card or EM file memory, execute the expansion memory format command. If the error cannot be reset with the above corrections, replace the memory.
16#00002510	The end station setting is wrong.	Set the end station correctly.
16#00002601	Protection is already cleared.	You do not need to clear protection.
16#00002602	The password was wrong.	Specify the correct password.
16#00002604	The data is protected.	<ul style="list-style-type: none"> Execute the command again after clearing the write protection. Wait for the service that is currently in execution to end or stop the service, and then execute the command again.
16#00002605	The service is busy.	Wait for the service that is currently in execution to end or stop the service, and then execute the command again.
16#00002606	The service is stopped.	Execute the relevant service as required.
16#00002607	You do not have the execution right.	<ul style="list-style-type: none"> Execute the operation from the node that accessed the data link. If the error still occurs after restarting, replace the Controller.
16#00002608	The environment is not set.	Make the necessary settings.
16#00002609	The required items are not set.	Set the required items.
16#0000260A	The specified number is already defined.	Execute the command again after changing the specified number to an action or transition number that is not already registered.
16#0000260B	The error cannot be reset.	Remove the cause of the error and then execute the error reset command.
16#00003001	You do not have access rights.	Wait for the access right to be cleared and then execute the command again.
16#00004001	The service was interrupted.	Execute the command again after clearing the cause of the service interruption.

Note In addition to the codes in the above table, the values of bits 6, 7, and 15 in the end code can be TRUE. If the value of bit 6 or 7 is TRUE, there is an error in the CPU Unit at the destination. If the value of bit 15 is TRUE, an error occurred during a network relay.

Sample Programming

In this sample, a no-protocol command is sent to the barcode reader that is connected to serial port 2 of a CJ-series Serial Communications Unit (unit number 0, device name 'Barcode'). The scene number acquisition command (@READ) is sent. The send data is the contents of the array variable *SendDat[]*. There is no start code and the end code is 16#0D (CR).

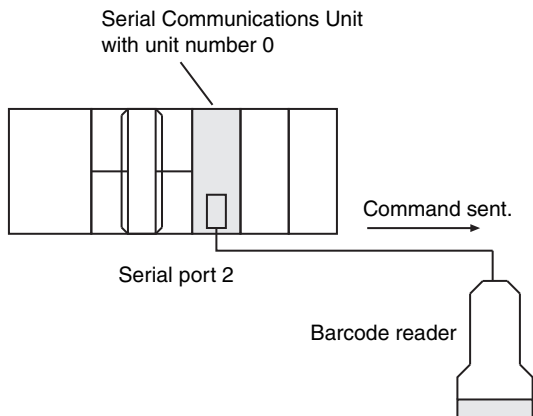

The settings of Serial Communications Unit are given in the following table.

Item	Set value
Port 2: User-specified Setting Inclusion	User settings
Port 2: Serial Communications Mode	No-protocol
Port 2: Data Length	8 bits
Port 2: Stop Bits	1 bit
Port 2: Parity	No
Port 2: Baud Rate	38,400 bps
Port 2: No-Protocol End Code	D
Port 2: No-Protocol Start Code Inclusion Setting	No
Port 2: No-Protocol End Code Inclusion Setting	Yes (Specify a desired end code.)

The text string '@READ' is separated into individual characters and the character codes are stored in the array elements of *SendDat[]*. Therefore, BYTE#16#40 (@) is stored in *SendData[0]*, BYTE#16#52(R) is stored in *SendData[1]*, etc. The StringToAry instruction is used to store the character codes.

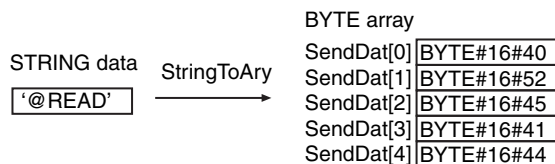

Definitions of Global Variables

Global Variables

Name	Data type	AT*1	Comment
Barcode_P2_NopSerialSendExecSta	BOOL	IOBus://rack#0/slot#0/P2_NopSta/P2_NopSerialSendExecSta	SerialSend Instruction Execution Flag

*1 AT when the Serial Communications Unit is mounted to slot number 0 in rack number 0.

LD

Internal Variables	Variable	Data type	Initial value	Comment
	OperatingEnd	BOOL	FALSE	Processing completed
	Trigger	BOOL	FALSE	Execution condition
	Operating	BOOL	FALSE	Processing
	InPort	_sPORT	(UnitNo:=_CBU_No00, PhysicPortNo:=0)	Port settings
	SendDat	ARRAY[0..4] OF BYTE	[5(16#0)]	Send data
	RS_instance	RS		
	SerialSend_instance	SerialSend		

External Variables	Variable	Data type	Comment
	_Port_isAvailable	BOOL	Network Communications Instruction Enabled Flag
	Barcode_P2_NopSerialSendExecSta	BOOL	SerialSend Instruction Execution Flag

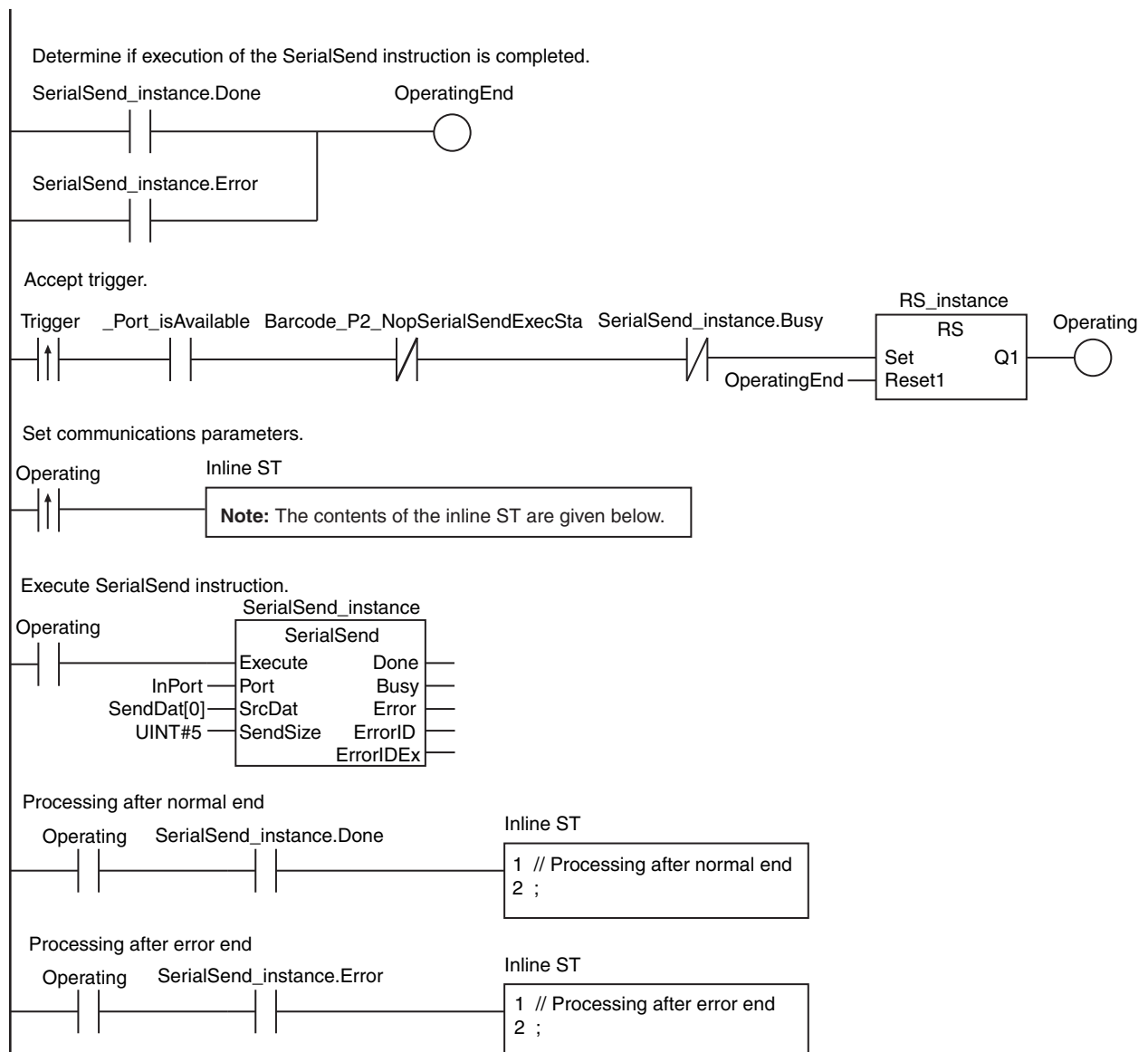

Contents of Inline ST

```
StringToAry(In      := '@READ', AryOut:=SendDat[0]); // Prepare SendDat [].  
InPort.UnitNo      := _CBU_No00;                    // Serial Communications Unit with unit number 0  
InPort.PhysicPortNo:=USINT#2;                       // Serial port 2
```

ST

Internal Variables	Variable	Data type	Initial value	Comment
	Trigger	BOOL	FALSE	Execution condition
	LastTrigger	BOOL	FALSE	Value of Trigger from previous task period
	OperatingStart	BOOL	FALSE	Processing started
	Operating	BOOL	FALSE	Processing
	InPort	_sPORT	(UnitNo:=_CBU_No00, PhysicPortNo:=0)	Port settings
	SendDat	ARRAY[0..4] OF BYTE	[5(16#0)]	Send data
	SerialSend_instance	SerialSend		

External Variables	Variable	Data type	Comment
	_Port_isAvailable	BOOL	Network Communications Instruction Enabled Flag
	Barcode_P2_NopSerialSendExecSta	BOOL	SerialSend Instruction Execution Flag

```

// Detect when Trigger changes to TRUE.
IF ( (Trigger=TRUE) AND (LastTrigger=FALSE) AND (_Port_isAvailable=TRUE)
    AND (Barcode_P2_NopSerialSendExecSta=FALSE) AND (SerialSend_instance.Busy=FALSE) ) THEN
    OperatingStart:=TRUE;
    Operating      :=TRUE;
END_IF;
LastTrigger:=Trigger;

// Set communications parameters and initialize SerialSend instruction.
IF (OperatingStart=TRUE) THEN
    SerialSend_instance(
        Execute:=FALSE,
        SrcDat :=SendDat[0]);
    StringToAry(In      := '@READ', AryOut:=SendDat[0]);
    InPort.UnitNo      :=_CBU_No00; // Serial Communications Unit with unit number 0
    InPort.PhysicPortNo :=USINT#2;  // Serial port 2
    OperatingStart     :=FALSE;
END_IF;

// Execute SerialSend instruction.
IF (Operating=TRUE) THEN
    SerialSend_instance(
        Execute :=TRUE,
        Port     :=InPort, // Port settings
        SrcDat   :=SendDat[0], // Send data
        SendSize :=UINT#5); // Send data size

    IF (SerialSend_instance.Done=TRUE) THEN
        // Processing after normal end
        Operating:=FALSE;
    END_IF;

    IF (SerialSend_instance.Error=TRUE) THEN
        // Processing after error end
        Operating:=FALSE;
    END_IF;
END_IF;

```

SerialRcv and SerialRcvNoClear

The SerialRcv and SerialRcvNoClear instructions receive data in No-protocol Mode from a serial port on a Serial Communications Unit.

SerialRcv: Clears the receive buffer after reading the data.

SerialRcvNoClear: Does not clear the receive buffer after reading the data.

Instruction	Name	FB/ FUN	Graphic expression	ST expression
SerialRcv	SCU Receive Serial	FB		SerialRcv_instance(Execute, Port, Size, DstDat, Done, Busy, Error, ErrorID, ErrorIDEx, RcvSize);
SerialRcvNoClear	SCU Receive Serial without Receive Buffer Clear	FB		SerialRcvNoClear_instance(Execute, Port, Size, DstDat, Done, Busy, Error, ErrorID, ErrorIDEx, RcvSize);



Precautions for Correct Use

You cannot use this instruction in an NX-series CPU Unit.

Variables

Name	Meaning	I/O	Description	Valid range	Unit	Default
Port	Destination port	Input	Destination port	---	---	---
Size	Receive data size		Size of receive data stored in <i>DstDat[]</i>	0 to 256	Bytes	1
DstDat[] (array)	Receive data array	In-out	Receive data array	Depends on data type.	---	---
RcvSize	Receive data storage size	Output	Size of receive data that was actually stored in <i>DstDat[]</i>	0 to 256	Bytes	---

	Boolean	Bit strings				Integers							Real numbers	Times, durations, dates, and text strings						
	BOOL	BYTE	WORD	DWORD	LWORD	USINT	UINT	UDINT	ULINT	SINT	INT	DINT	LINT	REAL	LREAL	TIME	DATE	TOD	DT	STRING
Port	Refer to <i>Function</i> for details on the structure <code>_sPORT</code> .																			
Size							OK													
DstDat[] (array)		OK																		
RcvSize							OK													

Function

First, data is received in No-protocol Mode from the serial port specified with *Port* and stored in the receive buffer in the Serial Communications Unit. This instruction transfers the number of bytes specified with receive data size *Size* from the receive buffer to receive data array *DstDat[]*.

After the data is transferred, the number of array elements that was actually stored in *DstDat[]* is assigned to the receive data storage size *RcvSize*.

If the amount of data in the receive buffer is smaller than *Size*, all of the data in the receive buffer is transferred to *DstDat[]*. The data size that was actually stored in *DstDat[]* is assigned to *RcvSize*.

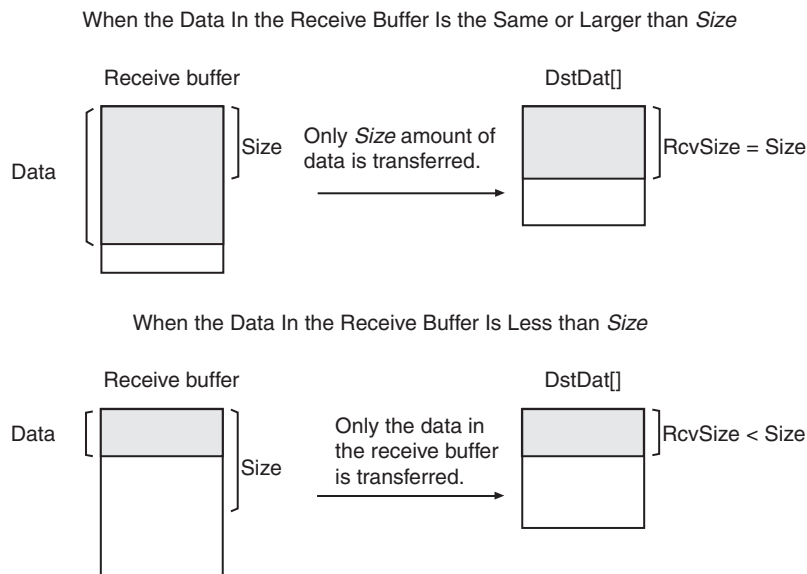

Start Code and End Code in Receive Data

Device variables are used in the user program to recognize the start code and end code in the receive data. The start and end codes are deleted from the receive data before it is stored in *DstDat[]*.

Code to attach	Device variable for port 1	Value
Specified start code	P1_NopStartCodeYNCfg	TRUE
	P1_NopStartCodeCfg	Start code (16#00 to 16#FF)
Specified end code	P1_NopEndCodeYNCfg	TRUE
	P1_NopCRLFCfg	FALSE
	P1_NopEndCodeCfg	End code (16#00 to 16#FF)
CR+LF as end code	P1_NopEndCodeYNCfg	TRUE
	P1_NopCRLFCfg	TRUE

If you add start and end codes, the maximum number of bytes to receive is 259 (1-byte start code, 2-byte end code (for CR+LF specification), and 256 bytes of send data).

Data Types of Destination Port *Port*

The data type of destination port *Port* is the structure `_sPORT`. The specifications are as follows:

Name	Meaning	Description	Data type	Valid range	Unit	Default
Port	Destination port	Destination port	<code>_sPORT</code>	---	---	---
UnitNo	Unit number	Unit number of Serial Communications Unit	<code>_eUnitNo</code>	<code>_CBU_No00</code> to <code>_CBU_No15</code>		<code>_CBU_No00</code>
PhysicPortNo	Serial port number	Serial port number on Serial Communications Unit	USINT	1 or 2	---	1

Timing Chart

The following figure shows a timing chart.

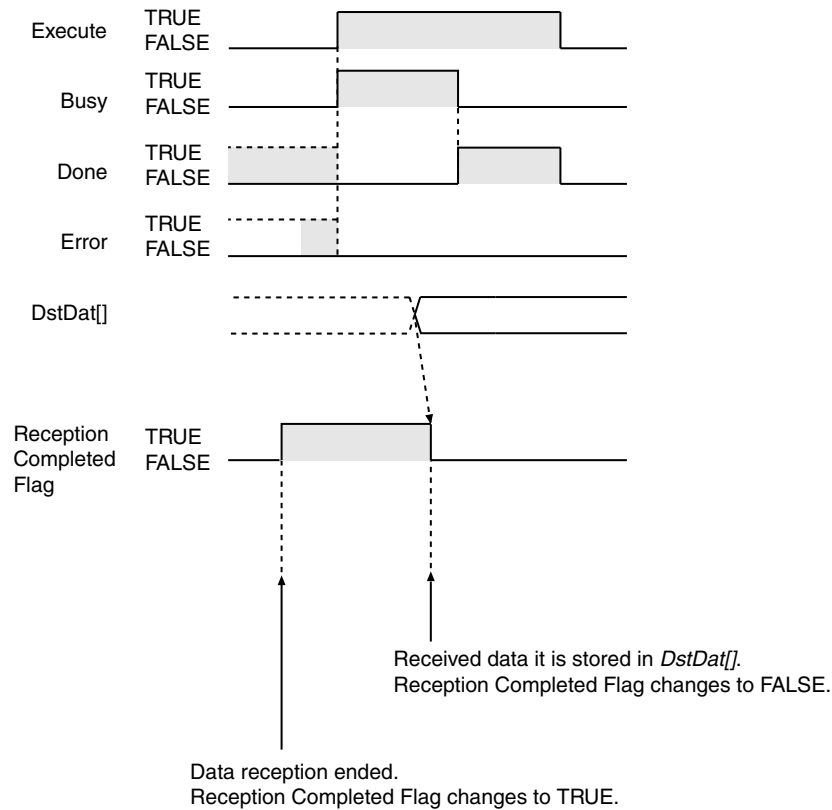

Difference between the SerialRcv and SerialRcvNoClear Instructions

The SerialRcv and SerialRcvNoClear instructions are different in whether the receive buffer is cleared after data is transferred from the receive buffer to *DstDat[]*.

The SerialRcv instruction clears the receive buffer after it transfers the data. Therefore, if the data in the receive buffer is larger than *Size*, the remaining data is discarded after the transfer.

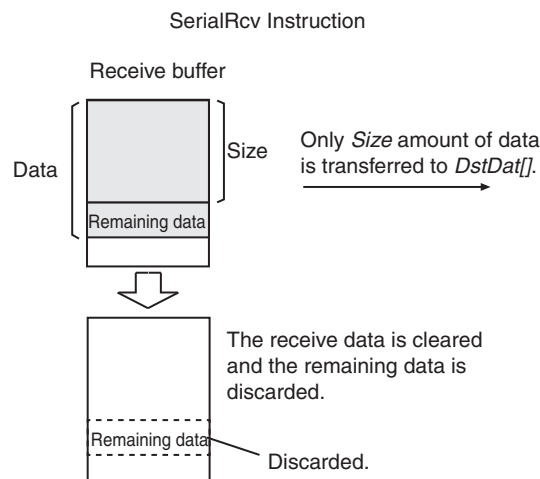

The SerialRcvNoClear instruction clears only the data that was transferred after the data transfer. The data that remains in the receive buffer is moved to the front of the receive buffer. If new data enters the receive buffer after that, it is stored after the data that was moved to the front of the buffer.

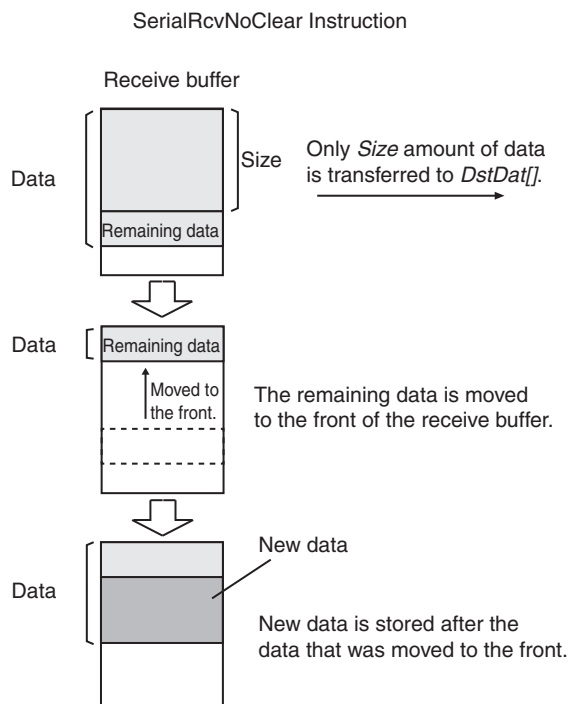

Related System-defined Variables

Name	Meaning	Data type	Description
_Port_numUsingPort	Number of Used Ports	USINT	This is the number of ports that are currently used.
_Port_isAvailable	Network Communications Instruction Enabled Flag	BOOL	TRUE: A port is available. FALSE: A port is not available.

Related Semi-user-defined Variables

Name	Meaning	Data type	Description
P#_NopRcvOvfSta*	Reception Overflow Flag	BOOL	TRUE: The Unit received more than the specified amount of data (i.e., data was received after the Reception Completed Flag changed to TRUE). FALSE: The Unit did not receive more than the specified number of bytes.
P#_NopRcvCompleteSta*	Reception Completed Flag	BOOL	TRUE: Reception was completed. FALSE: No data received or currently receiving data.
P#_NopRcvCntSta*	Reception Counter	UINT	16#0000 to 16#0100: Number of bytes of receive data
P#_NopStartCodeYNCfg*	No-protocol Start Code Enable	BOOL	TRUE: Start code FALSE: None
P#_NopEndCodeYNCfg*	No-protocol End Code Enable	BOOL	TRUE: End code FALSE: None
P#_NopCRLFcfg*	No-protocol CR LF Specification	BOOL	TRUE: CR+LF FALSE: No CR+LF

Name	Meaning	Data type	Description
P#_NopRcvDatSzCfg*	Number of No-protocol Receive Data Bytes	USINT	16#01 to 16#FF: 1 to 255 bytes 16#00: 256 bytes
P#_NopStartCodeCfg*	No-protocol Start Code	USINT	16#00 to 16#FF
P#_NopEndCodeCfg*	No-protocol End Code	USINT	16#00 to 16#FF
P#_TransErr*	Transmission Error	BOOL	TRUE: Error occurred. FALSE: No error occurred.
P#_OverRunErr*	Overrun Error	BOOL	TRUE: Error occurred. FALSE: No error occurred.

* “#” denotes the port number on the Serial Communications Unit.

Additional Information

- The Reception Completed Flag (*P#_NopRcvCompleteSta*) changes to TRUE at the following times.
 - The amount of data set in Number of No-protocol Receive Data Bytes (*P#_NopRcvDatSzCfg*) is received.
 - The specified end code is received.
 - A total of 256 bytes of data is received.
- The Reception Overflow Flag (*P#_NopRcvOvfSta*) changes to TRUE at the following times.
 - Data is received when this instruction is not executed and the Reception Completed Flag (*P#_NopRcvCompleteSta*) is TRUE.
 - More than the amount of data set in Number of No-protocol Receive Data Bytes (*P#_NopRcvDatSzCfg*) is received.
- Refer to the following manual for details on no-protocol communications.
 - *CJ-series Serial Communications Units Operation Manual for NJ-series CPU Unit* (Cat. No. W494)

Precautions for Correct Use

- Execution of this instruction is continued until processing is completed even if the value of *Execute* changes to FALSE or the execution time exceeds the task period. The value of *Done* changes to TRUE when processing is completed. Use this to confirm normal completion of processing.
- Refer to *Using this Section* on page 2-3 for a timing chart for *Execute*, *Done*, *Busy*, and *Error*.
- Execute the instruction only when the Reception Completed Flag (*P#_NopRcvCompleteSta*) is TRUE.
- When data is received, always execute this instruction to transfer the data in the receive buffer to *DstDat[]*. No more data is received until the previous data is transferred.
- Reception stops automatically after 259 bytes of data is received. If this instruction is not executed after that and more data is received, Overrun Error (*P#_OverRunErr*) changes to TRUE.
- Even when a start or end code is attached, do not include it in the value of *Size*.
- You can use this instruction only for a Serial Communications Unit's serial port that is set to No-protocol Mode.
- If the value of *Size* is 0, the data in the receive buffer is not transferred to *DstDat[]*. If that occurs, the Reception Completed Flag (*P#_NopRcvCompleteSta*) and Reception Overflow Flag (*P#_NopRcvOvfSta*) will change to FALSE. Also, the Reception Counter (*P#_NopRcvCntSta*) will be 0.
- The instruction is executed only when there is an available port. Therefore, use the system-defined variable *_Port_isAvailable* (Network Communications Instruction Enabled Flag) in an N.O. execution condition for the instruction.
- Execute the instruction only when the Reception Completed Flag (*P#_NopRcvCompleteSta*) is TRUE.

- The instruction is not executed while *Busy* is TRUE. Therefore, use *Busy* in an N.C. execution condition for the instruction.
- If the instruction is used in ST, make sure that the instruction is processed each task period as long as instruction execution continues. Otherwise, normal processing is sometimes not possible.
- The receive buffer in the Serial Communications Unit is cleared when the SerialRcv instruction is executed. Therefore, you cannot separate the data in the receive buffer to transfer it to *DstDat[]*.
- For the SerialRcv instruction, any receive data that exceeds the size specified with *Size* is discarded the next time the SerialRcv instruction is executed.
- An error occurs in the following cases. *Error* will change to TRUE.
 - The serial communications mode is not set to No-protocol Mode when the instruction is executed.
 - The value of *_Port_isAvailable* is FALSE.
 - The value of *Port.UnitNo* or *Port.PhysicPortNo* is outside of the valid range.
 - There is no CJ-series Serial Communications Unit with the specified unit number.
 - The value of *Size* is outside of the valid range.
 - The value of *Size* exceeds the size of *DstDat[]*.
 - Communications fail.
 - The instruction is executed during a Unit restart.
- For this instruction, expansion error code *ErrorIDEx* gives the communications response code. The values and meanings are listed in the following table. An expansion error code is output to *ErrorIDEx* when the value of error code *ErrorID* is WORD#16#0800.

Value	Error	Correction
16#00000001	The communications service was interrupted.	<ul style="list-style-type: none"> • Check the data link execution status. • Check the capacity of the transfer destination area on the third node.
16#00000101	The local node is not part of the network.	Make the local node part of the network.
16#00000102	A token timeout occurred.	Set the local node address to within the maximum node address.
16#00000103	The retry count was exceeded.	Perform internode tests. If communications is not normal, check the operating environment.
16#00000104	The allowable number of send frames was exceeded.	Check the status of events in the network and reduce the number of events in each task period. Or, increase the number of allowable send frames.
16#00000105	The IP address of the local node is out of range.	Set the rotary switches on the Serial Communications Unit correctly.
16#00000106	The IP address of the local node is also used by another node in the network.	Change one of the node addresses that are duplicated.
16#00000201	The remote node is not part of the network.	Make the remote node part of the network.
16#00000202	A Unit with the specified unit address does not exist at the destination.	Correctly set the unit address for the destination network address.
16#00000203	The third node is not part of the network.	<ul style="list-style-type: none"> • Check the address of the Unit that is the third node. • Specify only one node for the third node.
16#00000204	The remote node is busy.	Increase the setting of the number of retries or correct the system so that communications traffic is not concentrated on the remote node.
16#00000205	A response timeout occurred.	Check the settings of the communications parameters.
16#00000206	There is an error in the transmission path.	<ul style="list-style-type: none"> • Attempt retries. • If this error occurs frequently, check for noise.
16#00000301	A Communications Controller Error occurred.	Refer to the operation manual for the relevant Unit and make suitable corrections.
16#00000302	There is an error in the CPU Unit at the remote node.	Refer to the manual for the CPU Unit at the remote node and remove the error.

Value	Error	Correction
16#00000303	There is an error in the relevant Controller and a response is not returned.	Check the communications status on the network and restart the relevant Controller. If the error still occurs, replace the relevant Controller.
16#00000304	The unit number setting is not correct.	Set the rotary switches on the Serial Communications Unit correctly.
16#00000401	The command that was sent is not supported.	Set the command array correctly.
16#00000402	The Unit model or version is not supported.	Check the Unit model and version.
16#00000501	The remote address setting is wrong.	Set the destination address in the routing tables.
16#00000502	Routing tables are not registered.	Set the source node, destination node, and relay nodes in the routing tables.
16#00000503	There is an error in the routing tables.	Correct the settings in the routing tables.
16#00000504	There are too many relay points.	Restructure the networks or correct the routing tables so that commands are used within a three-layer range.
16#00001001	The command is too long.	Set the command array correctly.
16#00001002	The command is too short.	Set the command array correctly.
16#00001003	The number of write elements that is specified in the command does not agree with the number of write data.	Specify the same number of write elements and write data.
16#00001004	The command format is incorrect.	Set the command array correctly.
16#00001005	There is an error in the header.	Correct the settings in the routing tables.
16#00001101	The area type does not exist.	Refer to the command variables and parameter type codes and set the relevant codes.
16#00001102	An access size is wrong.	Correctly set the variable and parameter access sizes.
16#00001103	An out-of-range address was specified.	Specify an address that is within the process range.
16#00001104	The address range was exceeded.	<ul style="list-style-type: none"> Specify an address that is within the process range. Correct the settings in the data link table.
16#00001106	A communications sequence number that is not registered was specified.	Correct the communications sequence number or add the sequence with the CX-Protocol.
16#00001109	An interrelationship error occurred.	<ul style="list-style-type: none"> Correct the size relationships in the command data. Correct the settings in the data link table.
16#0000110A	Data is redundant.	<ul style="list-style-type: none"> Cancel the current process or wait for it to be completed before you execute the command. Correct the settings in the data link table.
16#0000110B	The response is too long.	Set the number of elements in the command array correctly.
16#0000110C	This is another parameter error.	Set the command array correctly.
16#00002002	The data is protected.	Execute the command again after clearing the protection.
16#00002003	There is no registered table.	Set the table correctly.
16#00002004	There is no data that matches the search data.	Set the search data correctly.
16#00002005	The relevant program number does not exist.	Set a valid program number.
16#00002006	The relevant file does not exist.	Set the file name correctly, including the subdirectory names.
16#00002007	A verification error occurred.	<ul style="list-style-type: none"> Check the contents of memory and write the correct data. Check the contents of the file.

Value	Error	Correction
16#00002101	Access is not possible because the area is read-only.	Execute the command again after clearing the write protection.
16#00002102	The data is protected or the data link table cannot be written.	<ul style="list-style-type: none"> Execute the command again after clearing the write protection. Set the system settings in the data link table.
16#00002103	Registration is not possible.	<ul style="list-style-type: none"> Create the file after deleting unnecessary files or prepare new file memory. Execute the command again after closing open files.
16#00002105	The relevant program number does not exist.	Set a valid program number.
16#00002106	The relevant file does not exist.	Set the file name correctly, including the subdirectory names.
16#00002107	A file with the same name already exists.	Execute the command again after changing the name of the file to write.
16#00002108	The change is not possible because an error occurred when trying to make it.	Correct the settings.
16#00002201	The operation was not possible because a protocol macros is already in execution.	Use an N.C. program input for the Protocol Macro Execution Flag.
16#00002202	The operating mode is wrong.	Check the operating mode.
16#00002203	The operating mode is wrong for the instruction (PROGRAM mode).	Check the operating mode of the Controller.
16#00002204	The operating mode is wrong for the instruction (DEBUG mode).	Check the operating mode of the Controller.
16#00002205	The operating mode is wrong for the instruction (MONITOR mode).	Check the operating mode of the Controller.
16#00002206	The operating mode is wrong for the instruction (RUN mode).	Check the operating mode of the Controller.
16#00002207	The specified mode is not the polling node.	Confirm which node is the polling node of the network.
16#00002208	The operating mode is wrong for the instruction.	Check step activation status.
16#00002211	The Unit is busy.	Increase the setting of the number of retries or correct the system so that communications traffic is not concentrated on the relevant Unit.
16#00002301	The file device does not exist.	Insert the media. Or, format the EM.
16#00002302	There is no file memory.	Check the file memory device.
16#00002303	There is no built-in clock.	Check the specifications of the model.
16#00002401	A checksum error occurred in the protocol macro data or the data transfer is not yet completed.	Transfer the protocol macro data from the CX-Protocol again.
16#00002502	There is an error in the part of memory for processing.	Transfer the correct data to memory.
16#00002503	The registered I/O Unit configuration does not agree with the physical Unit configuration.	Check the I/O Unit configuration.
16#00002504	There are too many local or remote I/O points.	Set the number of local and remote I/O points correctly.
16#00002505	An error occurred in a data transmission between the CPU Unit and a CPU Bus Unit.	Check the Units and the connecting cables. After removing the error, execute a command to reset the error.
16#00002506	The same rack number, unit number, or I/O address is set more than once.	Correct the settings so that each number is unique.
16#00002507	An error occurred in a data transmission between the CPU Unit and an I/O Unit.	Check the Units and the connecting cables. After removing the error, execute a command to reset the error.
16#00002509	There is an error in SYSMAC BUS/2 data transmission.	Check the Units and the connecting cables. After removing the error, execute a command to reset the error.

Value	Error	Correction
16#0000250A	An error occurred in a CPU Bus Unit data transmission.	Check the Units and the connecting cables. After removing the error, execute a command to reset the error.
16#0000250D	The same word setting is used more than once.	Set the I/O words correctly.
16#0000250F	There is an error in memory.	<ul style="list-style-type: none"> For internal memory, execute the command again after writing the correct data. For a Memory Card or EM file memory, execute the expansion memory format command. If the error cannot be reset with the above corrections, replace the memory.
16#00002510	The end station setting is wrong.	Set the end station correctly.
16#00002601	Protection is already cleared.	You do not need to clear protection.
16#00002602	The password was wrong.	Specify the correct password.
16#00002604	The data is protected.	<ul style="list-style-type: none"> Execute the command again after clearing the write protection. Wait for the service that is currently in execution to end or stop the service, and then execute the command again.
16#00002605	The service is busy.	Wait for the service that is currently in execution to end or stop the service, and then execute the command again.
16#00002606	The service is stopped.	Execute the relevant service as required.
16#00002607	You do not have the execution right.	<ul style="list-style-type: none"> Execute the operation from the node that accessed the data link. If the error still occurs after restarting, replace the Controller.
16#00002608	The environment is not set.	Make the necessary settings.
16#00002609	The required items are not set.	Set the required items.
16#0000260A	The specified number is already defined.	Execute the command again after changing the specified number to an action or transition number that is not already registered.
16#0000260B	The error cannot be reset.	Remove the cause of the error and then execute the error reset command.
16#00003001	You do not have access rights.	Wait for the access right to be cleared and then execute the command again.
16#00004001	The service was interrupted.	Execute the command again after clearing the cause of the service interruption.

Note In addition to the codes in the above table, the values of bits 6, 7, and 15 in the end code can be TRUE. If the value of bit 6 or 7 is TRUE, there is an error in the CPU Unit at the destination. If the value of bit 15 is TRUE, an error occurred during a network relay.



Version Information

A CPU Unit with unit version 1.03 or later, Sysmac Studio version 1.04 or higher, and a Serial Communications Unit with unit version 2.1 or later are required to use the SerialRcvNoClear instruction.

Sample Programming

In this sample, data that was read by the barcode reader that is connected to serial port 2 of a CJ-series Serial Communications Unit (unit number 0, device name 'Barcode') is received. The receive data is stored in array variable *RecvDat[]*. There is no start code and the end code is 16#0D (CR).

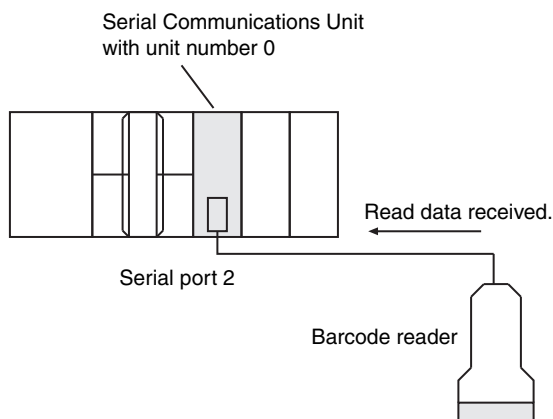

The settings of Serial Communications Unit are given in the following table.

Item	Set value
Port 2: User-specified Setting Inclusion	User settings
Port 2: Serial Communications Mode	No-protocol
Port 2: Data Length	8 bits
Port 2: Stop Bits	1 bit
Port 2: Parity	No
Port 2: Baud Rate	38,400 bps
Port 2: No-Protocol End Code	D
Port 2: No-Protocol Start Code Inclusion Setting	No
Port 2: No-Protocol End Code Inclusion Setting	Yes (Specify a desired end code.)

The number from the barcode reader is separated into individual characters and bit strings for the character codes are stored in *RecvDat[]*. One element of the *RecvDat[]* array corresponds to one character from the barcode. First, the *AryToString* instruction is used to convert the data to a text string (*RecvStringDat*). Then, the *STRING_TO_ULINT* instruction is used to convert the data to an ULINT integer (*Code*).

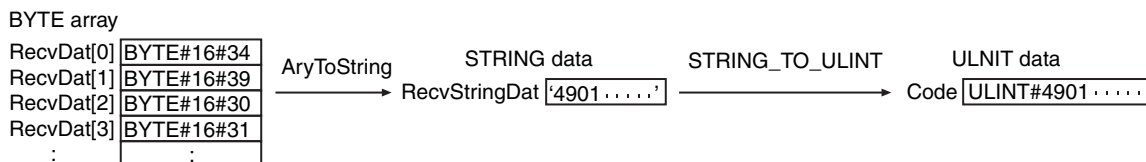

Definitions of Global Variables

Global Variables

Name	Data type	AT*1	Comment
Barcode_P2_NopRcvCompleteSta	BOOL	IOBus://rack#0/slot#0/P2_NopSta /P2_NopRcvCompleteSta	Reception Completed Flag

*1 AT when the Serial Communications Unit is mounted to slot number 0 in rack number 0.

LD

Internal Variables	Variable	Data type	Initial value	Comment
	OperatingEnd	BOOL	FALSE	Processing completed
	Trigger	BOOL	FALSE	Execution condition
	Operating	BOOL	FALSE	Processing
	InPort	_sPORT	(UnitNo:=_CBU_No00, PhysicPortNo:=0)	Port settings
	RecvDat	ARRAY[0..12] OF BYTE	[13(16#0)]	Receive data
	RecvSize	UINT	0	Receive data size
	RecvStringDat	STRING[255]	"	Barcode text string
	Code	ULINT	0	Barcode integer
	RS_instance	RS		
	SerialRcv_instance	SerialRcv		

External Variables	Variable	Data type	Comment
	_Port_isAvailable	BOOL	Network Communications Instruction Enabled Flag
	Barcode_P2_NopRcvCompleteSta	BOOL	Reception Completed Flag

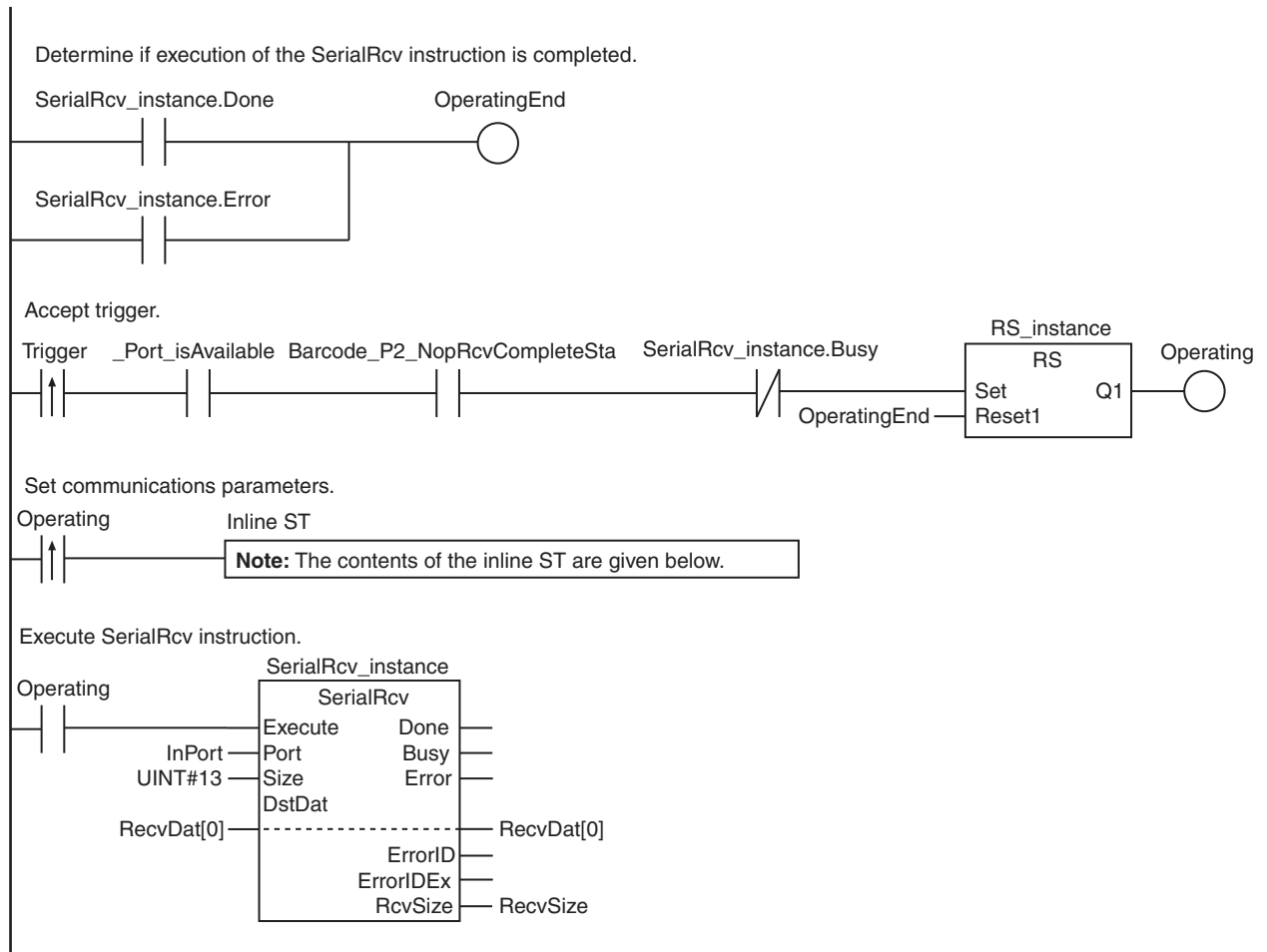

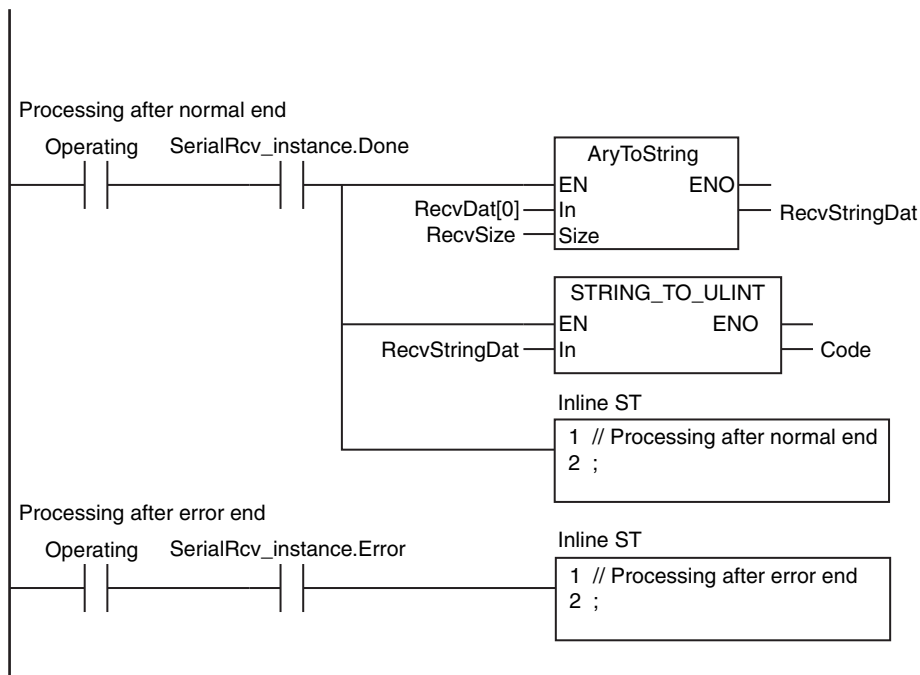

Contents of Inline ST

```
InPort.UnitNo      :=_CBU_No00; // Serial Communications Unit with unit number 0
InPort.PhysicPortNo:=USINT#2;  // Serial port 2
```

ST

Internal Variables	Variable	Data type	Initial value	Comment
	Trigger	BOOL	FALSE	Execution condition
	LastTrigger	BOOL	FALSE	Value of Trigger from previous task period
	OperatingStart	BOOL	FALSE	Processing started
	Operating	BOOL	FALSE	Processing
	InPort	_sPORT	(UnitNo:=_CBU_No00, PhysicPortNo:=0)	Port settings
	RecvDat	ARRAY[0..12] OF BYTE	[13(16#0)]	Receive data
	RecvSize	UINT	0	Receive data size
	RecvStringDat	STRING[255]	"	Barcode text string
	Code	ULINT	0	Barcode integer
	SerialRcv_instance	SerialRcv		

External Variables	Variable	Data type	Comment
	_Port_isAvailable	BOOL	Network Communications Instruction Enabled Flag
	Barcode_P2_NopRcvCompleteSta	BOOL	Reception Completed Flag

```

// Detect when Trigger changes to TRUE.
IF ( (Trigger=TRUE) AND (LastTrigger=FALSE) AND (_Port_isAvailable=TRUE)
    AND (Barcode_P2_NopRcvCompleteSta=TRUE) AND (SerialRcv_instance.Busy=FALSE) ) THEN
    OperatingStart:=TRUE;
    Operating      :=TRUE;
END_IF;
LastTrigger:=Trigger;

// Set communications parameters and initialize SerialRcv instruction.
IF (OperatingStart=TRUE) THEN
    SerialRcv_instance(
        Execute:=FALSE,           // Initialize instance.
        Port   :=InPort,         // Port settings
        Size   :=UINT#13,        // Receive data size
        DstDat :=RecvDat[0],     // Receive data
        RcvSize=>RecvSize);      // Data size that was actually received
    InPort.UnitNo      :=_CBU_No00; // Serial Communications Unit with unit number 0
    InPort.PhysicPortNo :=USINT#2;  // Serial port 2
    OperatingStart     :=FALSE;
END_IF;

// Execute SerialRcv instruction.
IF (Operating=TRUE) THEN
    SerialRcv_instance(
        Execute :=TRUE,
        Port    :=InPort,
        Size    :=UINT#13,
        DstDat  :=RecvDat[0],
        RcvSize =>RecvSize);

    IF (SerialRcv_instance.Done=TRUE) THEN
        // Processing after normal end
        RecvStringDat :=AryToString(In:=RecvDat[0], Size:=RecvSize); // Convert character codes to a text string.
        Code          :=STRING_TO_ULINT(RecvStringDat);              // Convert text string to an integer.
        Operating     :=FALSE;
    END_IF;
END_IF;

```

```
IF (SerialRcv_instance.Error=TRUE) THEN
    // Processing after error end
    Operating:=FALSE;
END_IF;
END_IF;
```

SendCmd

The SendCmd instruction uses a serial gateway and sends a command to a Serial Communications Unit. Or, it sends an explicit command to a DeviceNet Unit or CompoNet Master Unit.

Instruction	Name	FB/ FUN	Graphic expression	ST expression
SendCmd	Send Command	FB	<pre> graph LR subgraph SendCmd_instance [SendCmd_instance] subgraph SendCmd_box [SendCmd] direction TB Execute --- Done DstNetAdr --- Busy CommPort --- Error CmdDat --- ErrorID CmdSize --- ErrorIDEx RespDat --- ErrorIDEx Option --- ErrorIDEx end end </pre>	SendCmd_instance(Execute, DstNetAdr, CommPort, CmdDat, CmdSize, RespDat, Option, Done, Busy, Error, ErrorID, ErrorIDEx);



Precautions for Correct Use

You cannot use this instruction in an NX-series CPU Unit.

Variables

Name	Meaning	I/O	Description	Valid range	Unit	Default
DstNetAdr	Destination network address	Input	Destination network address	---	---	---
CommPort	Destination serial port		Destination serial port	Only _NONE		_NONE
CmdDat[] (array)	Command array		Command to send	Depends on data type.		*
CmdSize	Command data size		Command data size	2 to maximum data length (depends on network type)	Bytes	2
Option	Response		Response monitoring and retry specifications	---	---	---
RespDat[] (array)	Response storage array	In-out	Array to store response	Depends on data type.	---	---

* If you omit an input parameter, the default value is not applied. A building error will occur.

	Boolean	Bit strings				Integers							Real numbers		Times, durations, dates, and text strings					
	BOOL	BYTE	WORD	DWORD	LWORD	USINT	UINT	UDINT	ULINT	SINT	INT	DINT	LINT	REAL	LREAL	TIME	DATE	TOD	DT	STRING
DstNetAdr																				
CommPort																				
CmdDat[] (array)		OK																		

	Boolean	Bit strings					Integers							Real numbers		Times, durations, dates, and text strings				
	BOOL	BYTE	WORD	DWORD	LWORD	USINT	UINT	UDINT	ULINT	SINT	INT	DINT	LINT	REAL	LREAL	TIME	DATE	TOD	DT	STRING
CmdSize							OK													
Option	Refer to <i>Function</i> for details on the structure <code>_sRESPONSE</code> .																			
RespDat[] (array)		OK																		

Function

The SendCmd instruction sends the contents of command array *CmdDat[]* to the destination specified with destination network address *DstNetAdr* and destination serial port *CommPort*. The command data size *CmdSize* specifies how many elements of *CmdDat[]* contain the command. The response that is returned is stored in response storage array *RespDat[]*.

The data type of *DstNetAdr* is structure `_sDNET_ADR`. The specifications are as follows:

Name	Meaning	Description	Data type	Valid range	Unit	Default
DstNetAdr	Destination network address	Destination network address	<code>_sDNET_ADR</code>	---	---	---
NetNo	Network address	Network address	USINT	0	---	0
NodeNo	Node address	Node address	USINT			
UnitNo	Unit address	Unit address	BYTE	Depends on data type.		16#00

The data type of *CommPort* is enumerated type `_ePORT`. The meanings of the enumerators of enumerated type `_ePORT` are as follows:

Enumerators	Meaning
<code>_NONE</code>	The destination is not a serial port in Host Link Mode.

The data type of *Option* is structure `_sRESPONSE`. The specifications are as follows:

Name	Meaning	Description	Data type	Valid range	Unit	Default
Option	Response	Response monitoring and retry specifications	<code>_sRESPONSE</code>	---	---	---
isNonResp	No response	TRUE:Response is not required. FALSE:Response is required.	BOOL	Depends on data type.	---	FALSE
TimeOut	Timeout time	Timeout time 0: 2.0 s	UINT			
Retry	Retry count	Retry count	USINT	0 to 15	Times	0

If the value of the Response Not Necessary Flag (*Option.isNonResp*) is FALSE and the response does not return within the value set for the Timeout Time (*Option.TimeOut*), the command is resent until there is a response. *Option.Retry* specifies the number of retries. The timeout time is *Option.TimeOut* multiplied by 0.1 s. However, if the value of *Option.TimeOut* is 0, the timeout time is 2.0 s. The default value of *Option.TimeOut* is 2.0 s. No responses are received for broadcast data. Also, the command is not resent.

Related System-defined Variables

Name	Meaning	Description
<code>_Port_numUsingPort</code>	Number of Used Ports	This is the number of ports that are currently used.
<code>_Port_isAvailable</code>	Network Communications Instruction Enabled Flag	TRUE: A port is available. FALSE: A port is not available.

Additional Information

- The command or response is sometimes lost during communications due to noise or other factors. You can increase reliability by setting *Option.Retry* to a value higher than 0 to perform retry processing when a response is not returned.
- To specify a serial port with the serial gateway function, specify the unit address of the serial port for *DstNetAdr.UnitNo*. The unit addresses of the ports on Serial Communications Units are as follows:
 - Port 1
Unit address = $\text{BYTE\#16\#80} + \text{BYTE\#16\#04} \times \text{unit number (hex)}$
Example for Unit Number 1
 $\text{BYTE\#16\#80} + \text{BYTE\#16\#04} \times 1 = \text{BYTE\#16\#84}$
 - Port 2
Unit address = $\text{BYTE\#16\#81} + \text{BYTE\#16\#04} \times \text{unit number (hex)}$
Example for Unit Number 2
 $\text{BYTE\#16\#81} + \text{BYTE\#16\#04} \times 2 = \text{BYTE\#16\#89}$

Precautions for Correct Use

- The instruction is executed only when there is an available port. Therefore, use the system-defined variable *_Port_isAvailable* (Network Communications Instruction Enabled Flag) in an N.O. execution condition for the instruction.
- Execution of this instruction is continued until processing is completed even if the value of *Execute* changes to FALSE or the execution time exceeds the task period. The value of *Done* changes to TRUE when processing is completed. Use this to confirm normal completion of processing.
- If the instruction is used in ST, make sure that the instruction is processed each task period as long as instruction execution continues. Otherwise, normal processing is sometimes not possible.
- The command is not sent if the value of *CmdSize* is 0. When the instruction is executed, the value of *Done* changes to TRUE.
- Refer to *Using this Section* on page 2-3 for a timing chart for *Execute*, *Done*, *Busy*, and *Error*.
- An error occurs in the following cases. *Error* will change to TRUE.
 - The value of *CommPort* is outside of the valid range.
 - The value of a member of *DstNetAdr* is outside of the valid range.
 - The value of *CmdSize* is outside of the valid range.
 - The value of a member of *Option* is outside of the valid range.
 - The value of *CmdSize* exceeds the size of *CmdDat[]*.
 - The response size exceeds the size of *RespDat[]*.
 - The value of *_Port_isAvailable* is FALSE.
 - Communications fail.

- For this instruction, expansion error code *ErrorIDEx* gives the communications response code. The values and meanings are listed in the following table. An expansion error code is output to *ErrorIDEx* when the value of error code *ErrorID* is WORD#16#0800.

Value	Error	Correction
16#00000001	The communications service was interrupted.	<ul style="list-style-type: none"> Check the data link execution status. Check the capacity of the transfer destination area on the third node.
16#00000101	The local node is not part of the network.	Make the local node part of the network.
16#00000102	A token timeout occurred.	Set the local node address to within the maximum node address.
16#00000103	The retry count was exceeded.	Perform internode tests. If communications is not normal, check the operating environment.
16#00000104	The allowable number of send frames was exceeded.	Check the status of events in the network and reduce the number of events in each task period. Or, increase the number of allowable send frames.
16#00000105	The IP address of the local node is out of range.	Set the rotary switches on the Serial Communications Unit correctly.
16#00000106	The IP address of the local node is also used by another node in the network.	Change one of the node addresses that are duplicated.
16#00000201	The remote node is not part of the network.	Make the remote node part of the network.
16#00000202	A Unit with the specified unit address does not exist at the destination.	Correctly set the unit address for the destination network address.
16#00000203	The third node is not part of the network.	<ul style="list-style-type: none"> Check the address of the Unit that is the third node. Specify only one node for the third node.
16#00000204	The remote node is busy.	Increase the setting of the number of retries or correct the system so that communications traffic is not concentrated on the remote node.
16#00000205	A response timeout occurred.	Check the settings of the communications parameters.
16#00000206	There is an error in the transmission path.	<ul style="list-style-type: none"> Attempt retries. If this error occurs frequently, check for noise.
16#00000301	A Communications Controller Error occurred.	Refer to the operation manual for the relevant Unit and make suitable corrections.
16#00000302	There is an error in the CPU Unit at the remote node.	Refer to the manual for the CPU Unit at the remote node and remove the error.
16#00000303	There is an error in the relevant Controller and a response is not returned.	Check the communications status on the network and restart the relevant Controller. If the error still occurs, replace the relevant Controller.
16#00000304	The unit number setting is not correct.	Set the rotary switches on the Serial Communications Unit correctly.
16#00000401	The command that was sent is not supported.	Set the command array correctly.
16#00000402	The Unit model or version is not supported.	Check the Unit model and version.
16#00000501	The remote address setting is wrong.	Set the destination address in the routing tables.
16#00000502	Routing tables are not registered.	Set the source node, destination node, and relay nodes in the routing tables.
16#00000503	There is an error in the routing tables.	Correct the settings in the routing tables.
16#00000504	There are too many relay points.	Restructure the networks or correct the routing tables so that commands are used within a three-layer range.
16#00001001	The command is too long.	Set the command array correctly.
16#00001002	The command is too short.	Set the command array correctly.

Value	Error	Correction
16#00001003	The number of write elements that is specified in the command does not agree with the number of write data.	Specify the same number of write elements and write data.
16#00001004	The command format is incorrect.	Set the command array correctly.
16#00001005	There is an error in the header.	Correct the settings in the routing tables.
16#00001101	The area type does not exist.	Refer to the command variables and parameter type codes and set the relevant codes.
16#00001102	An access size is wrong.	Correctly set the variable and parameter access sizes.
16#00001103	An out-of-range address was specified.	Specify an address that is within the process range.
16#00001104	The address range was exceeded.	<ul style="list-style-type: none"> Specify an address that is within the process range. Correct the settings in the data link table.
16#00001106	A communications sequence number that is not registered was specified.	Correct the communications sequence number or add the sequence with the CX-Protocol.
16#00001109	An interrelationship error occurred.	<ul style="list-style-type: none"> Correct the size relationships in the command data. Correct the settings in the data link table.
16#0000110A	Data is redundant.	<ul style="list-style-type: none"> Cancel the current process or wait for it to be completed before you execute the command. Correct the settings in the data link table.
16#0000110B	The response is too long.	Set the number of elements in the command array correctly.
16#0000110C	This is another parameter error.	Set the command array correctly.
16#00002002	The data is protected.	Execute the command again after clearing the protection.
16#00002003	There is no registered table.	Set the table correctly.
16#00002004	There is no data that matches the search data.	Set the search data correctly.
16#00002005	The relevant program number does not exist.	Set a valid program number.
16#00002006	The relevant file does not exist.	Set the file name correctly, including the subdirectory names.
16#00002007	A verification error occurred.	<ul style="list-style-type: none"> Check the contents of memory and write the correct data. Check the contents of the file.
16#00002101	Access is not possible because the area is read-only.	Execute the command again after clearing the write protection.
16#00002102	The data is protected or the data link table cannot be written.	<ul style="list-style-type: none"> Execute the command again after clearing the write protection. Set the system settings in the data link table.
16#00002103	Registration is not possible.	<ul style="list-style-type: none"> Create the file after deleting unnecessary files or prepare new file memory. Execute the command again after closing open files.
16#00002105	The relevant program number does not exist.	Set a valid program number.
16#00002106	The relevant file does not exist.	Set the file name correctly, including the subdirectory names.
16#00002107	A file with the same name already exists.	Execute the command again after changing the name of the file to write.
16#00002108	The change is not possible because an error occurred when trying to make it.	Correct the settings.
16#00002201	The operation was not possible because a protocol macros is already in execution.	Use an N.C. program input for the Protocol Macro Execution Flag.
16#00002202	The operating mode is wrong.	Check the operating mode.

Value	Error	Correction
16#00002203	The operating mode is wrong for the instruction (PROGRAM mode).	Check the operating mode of the Controller.
16#00002204	The operating mode is wrong for the instruction (DEBUG mode).	Check the operating mode of the Controller.
16#00002205	The operating mode is wrong for the instruction (MONITOR mode).	Check the operating mode of the Controller.
16#00002206	The operating mode is wrong for the instruction (RUN mode).	Check the operating mode of the Controller.
16#00002207	The specified mode is not the polling node.	Confirm which node is the polling node of the network.
16#00002208	The operating mode is wrong for the instruction.	Check step activation status.
16#00002211	The Unit is busy.	Increase the setting of the number of retries or correct the system so that communications traffic is not concentrated on the relevant Unit.
16#00002301	The file device does not exist.	Insert the media. Or, format the EM.
16#00002302	There is no file memory.	Check the file memory device.
16#00002303	There is no built-in clock.	Check the specifications of the model.
16#00002401	A checksum error occurred in the protocol macro data or the data transfer is not yet completed.	Transfer the protocol macro data from the CX-Protocol again.
16#00002502	There is an error in the part of memory for processing.	Transfer the correct data to memory.
16#00002503	The registered I/O Unit configuration does not agree with the physical Unit configuration.	Check the I/O Unit configuration.
16#00002504	There are too many local or remote I/O points.	Set the number of local and remote I/O points correctly.
16#00002505	An error occurred in a data transmission between the CPU Unit and a CPU Bus Unit.	Check the Units and the connecting cables. After removing the error, execute a command to reset the error.
16#00002506	The same rack number, unit number, or I/O address is set more than once.	Correct the settings so that each number is unique.
16#00002507	An error occurred in a data transmission between the CPU Unit and an I/O Unit.	Check the Units and the connecting cables. After removing the error, execute a command to reset the error.
16#00002509	There is an error in SYSMAC BUS/2 data transmission.	Check the Units and the connecting cables. After removing the error, execute a command to reset the error.
16#0000250A	An error occurred in a CPU Bus Unit data transmission.	Check the Units and the connecting cables. After removing the error, execute a command to reset the error.
16#0000250D	The same word setting is used more than once.	Set the I/O words correctly.
16#0000250F	There is an error in memory.	<ul style="list-style-type: none"> • For internal memory, execute the command again after writing the correct data. • For a Memory Card or EM file memory, execute the expansion memory format command. • If the error cannot be reset with the above corrections, replace the memory.
16#00002510	The end station setting is wrong.	Set the end station correctly.
16#00002601	Protection is already cleared.	You do not need to clear protection.
16#00002602	The password was wrong.	Specify the correct password.

Value	Error	Correction
16#00002604	The data is protected.	<ul style="list-style-type: none"> Execute the command again after clearing the write protection. Wait for the service that is currently in execution to end or stop the service, and then execute the command again.
16#00002605	The service is busy.	Wait for the service that is currently in execution to end or stop the service, and then execute the command again.
16#00002606	The service is stopped.	Execute the relevant service as required.
16#00002607	You do not have the execution right.	<ul style="list-style-type: none"> Execute the operation from the node that accessed the data link. If the error still occurs after restarting, replace the Controller.
16#00002608	The environment is not set.	Make the necessary settings.
16#00002609	The required items are not set.	Set the required items.
16#0000260A	The specified number is already defined.	Execute the command again after changing the specified number to an action or transition number that is not already registered.
16#0000260B	The error cannot be reset.	Remove the cause of the error and then execute the error reset command.
16#00003001	You do not have access rights.	Wait for the access right to be cleared and then execute the command again.
16#00004001	The service was interrupted.	Execute the command again after clearing the cause of the service interruption.

Note In addition to the codes in the above table, the values of bits 6, 7, and 15 in the end code can be TRUE. If the value of bit 6 or 7 is TRUE, there is an error in the CPU Unit at the destination. If the value of bit 15 is TRUE, an error occurred during a network relay.

Sample Programming

In this sample, the SendCmd instruction sends an explicit message via a DeviceNet Unit. This sample reads the vendor ID from the slave with node address 16#0B through the DeviceNet Unit with unit address 16#10.

The following communications specifications are used.

Item	Description
Unit address of DeviceNet Unit	16#10
Slave node address	16#0B
Service code	16#0E
Class ID	1
Instance ID	1
Attribute ID	1
Timeout time	2.0 s
Retry count	2

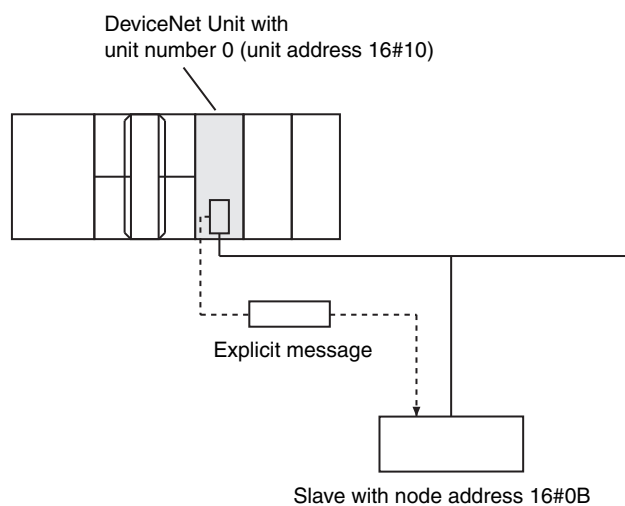

The contents of command array *SendDat[]* and response storage array *RecvDat[]* are as follows:

Command Array: BYTE array

Array element	Item	Content	Value
SendDat[0]	Command code	The command code to send an explicit message is 16#2801.	BYTE#16#28
SendDat[1]			BYTE#16#01
SendDat[2]	Slave node address	The node address is 16#0B.	BYTE#16#0B
SendDat[3]	Service code	The service code to read the value of a specified attribute (Get Attribute Single) is 16#0E.	BYTE#16#0E
SendDat[4]	Class ID	The class ID of the Identity object is 16#0001.	BYTE#16#00
SendDat[5]			BYTE#16#01
SendDat[6]	Instance ID	---	BYTE#16#00
SendDat[7]			BYTE#16#01
SendDat[8]	Attribute ID	The attribute ID of the vendor ID (Vendor ID) is 16#01.	BYTE#16#01

Response Storage Array: BYTE Array

Array element	Item	Content
RecvDat[0]	Command code	The command code to send an explicit message is 16#2801.
RecvDat[1]		

Array element	Item	Content
RecvDat[2]	Completion code	The completion code is 16#0000 for a normal end.
RecvDat[3]		
RecvDat[4]	Number of bytes received after the slave node address	4 bytes
RecvDat[5]		
RecvDat[6]	Slave node address	The node address is 16#0B for a normal end.
RecvDat[7]	Service code	The service code for a normal end is 16#8E.
RecvDat[8]	Vendor ID	Slave vendor ID.
RecvDat[9]		

Definitions of Global Variables

Global Variables

Name	Data type	AT*1	Comment
DeviceNet_OnlineSta	BOOL	IOBus://rack#0/slot#0/Unit2Sta /OnlineSta	Online

*1 AT when the Serial Communications Unit is mounted to slot number 0 in rack number 0.

LD

Internal Variables	Variable	Data type	Initial value	Comment
	OperatingEnd	BOOL	FALSE	Processing completed
	Trigger	BOOL	FALSE	Execution condition
	Operating	BOOL	FALSE	Processing
	InDNetAdr	_sDNET_ADR	(NetNo:=0, NodeNo:=0, UnitNo:=16#0)	Destination network address
	InOption	_sRESPONSE	(isNonResp:=FALSE, TimeOut:=0, Retry:=0)	Response
	SendDat	ARRAY[0..8] OF BYTE	[9(16#0)]	Send data
	RecvDat	ARRAY[0..9] OF BYTE	[10(16#0)]	Receive data
	RS_instance	RS		
	SendCmd_instance	SendCmd		

External Variables	Variable	Data type	Comment
	_Port_isAvailable	BOOL	Network Communications Instruction Enabled Flag

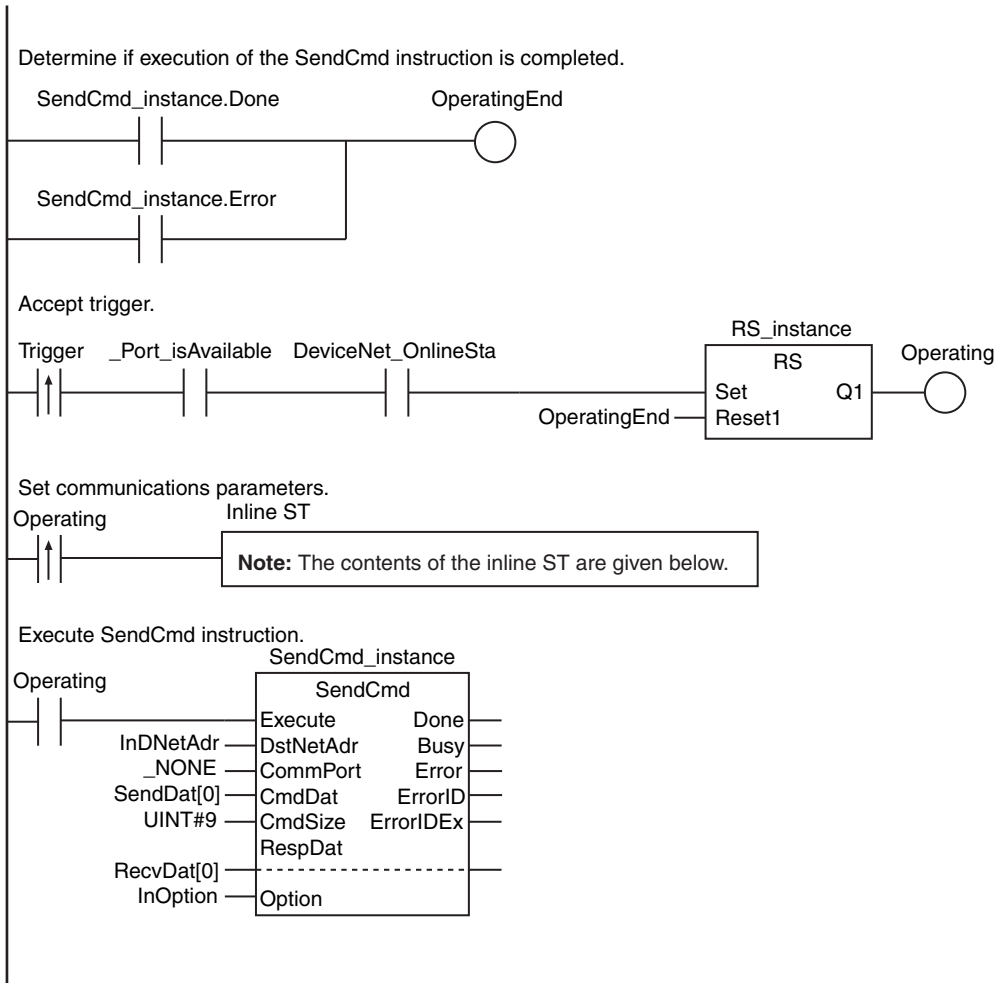

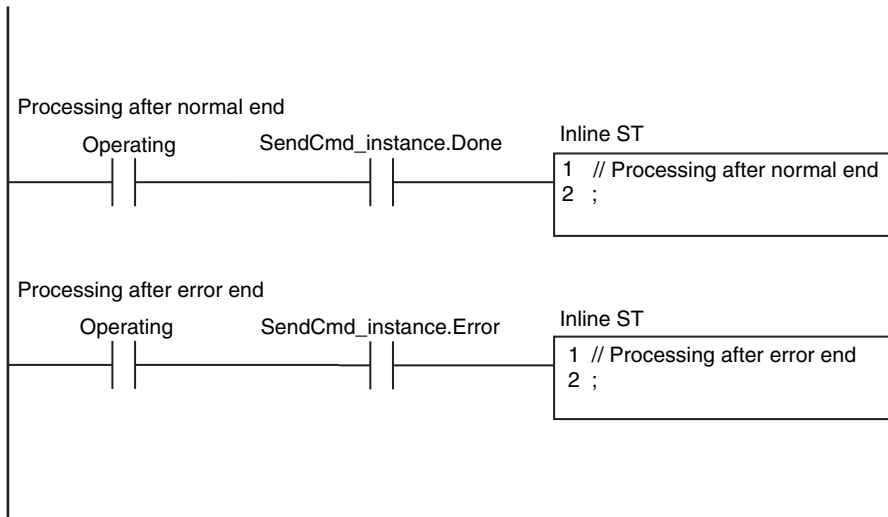

Contents of Inline ST

```

InDNetAdr.NetNo      :=USINT#0;      // Set network address.
InDNetAdr.NodeNo    :=USINT#0;
InDNetAdr.UnitNo    :=BYTE#16#10;
InOption.isNonResp  :=FALSE;        // Set response.
InOption.TimeOut    :=UINT#20;
InOption.Retry      :=USINT#2;
SendDat [0]         :=BYTE#16#28;    // Set command array.
SendDat [1]         :=BYTE#16#01;
SendDat [2]         :=BYTE#16#0B;
SendDat [3]         :=BYTE#16#0E;
SendDat [4]         :=BYTE#16#00;
SendDat [5]         :=BYTE#16#01;
SendDat [6]         :=BYTE#16#00;
SendDat [7]         :=BYTE#16#01;
SendDat [8]         :=BYTE#16#01;

```

ST

Internal Variables	Variable	Data type	Initial value	Comment
	Trigger	BOOL	FALSE	Execution condition
	LastTrigger	BOOL	FALSE	Value of <i>Trigger</i> from previous task period
	OperatingStart	BOOL	FALSE	Processing started
	Operating	BOOL	FALSE	Processing
	InDNetAdr	_sDNET_ADR	(NetNo:=0, NodeNo:=0, UnitNo:=16#0)	Destination network address
	InOption	_sRESPONSE	(isNonResp:=FALSE, TimeOut:=0, Retry:=0)	Response
	SendDat	ARRAY[0..8] OF BYTE	[9(16#0)]	Send data
	RecvDat	ARRAY[0..9] OF BYTE	[10(16#0)]	Receive data
	SendCmd_instance	SendCmd		

External Variables	Variable	Data type	Comment
	DeviceNet_OnlineSta	BOOL	Online
	_Port_isAvailable	BOOL	Network Communications Instruction Enabled Flag

```
// Detect when Trigger changes to TRUE.
IF ( (Trigger=TRUE) AND (LastTrigger=FALSE) AND (_Port_isAvailable=TRUE)
      AND (DeviceNet_OnlineSta=TRUE) ) THEN
  OperatingStart:=TRUE;
  Operating      :=TRUE;
END_IF;
LastTrigger:=Trigger;

// Set communications parameters and initialize SendCmd instruction.
IF (OperatingStart=TRUE) THEN
  SendCmd_instance(
    Execute      :=FALSE,
    DstNetAdr    :=InDNetAdr,
    CommPort     :=_NONE,
    CmdDat       :=SendDat [0],
    CmdSize      :=UINT#9,
    RespDat      :=RecvDat [0],
    Option       :=InOption);
  InDNetAdr.NetNo  :=USINT#0;      // Set network address.
  InDNetAdr.NodeNo :=USINT#0;
  InDNetAdr.UnitNo :=BYTE#16#10;
  InOption.isNonResp:=FALSE;      // Set response.
  InOption.TimeOut :=UINT#20;
  InOption.Retry   :=USINT#2;
  SendDat [0]      :=BYTE#16#28;  // Set command array.
  SendDat [1]      :=BYTE#16#01;
  SendDat [2]      :=BYTE#16#0B;
  SendDat [3]      :=BYTE#16#0E;
  SendDat [4]      :=BYTE#16#00;
  SendDat [5]      :=BYTE#16#01;
  SendDat [6]      :=BYTE#16#00;
  SendDat [7]      :=BYTE#16#01;
  SendDat [8]      :=BYTE#16#01;
  OperatingStart   :=FALSE;
END_IF;

// Execute SendCmd instruction.
IF (Operating=TRUE) THEN
```

```
SendCmd_instance(  
    Execute :=TRUE,  
    DstNetAdr:=InDNetAdr,  
    CommPort :=_NONE,  
    CmdDat :=SendDat[0],  
    CmdSize :=UINT#9,  
    RespDat :=RecvDat[0],  
    Option :=InOption);  
  
IF (SendCmd_instance.Done=TRUE) THEN  
    // Processing after normal end  
    Operating:=FALSE;  
END_IF;  
  
IF (SendCmd_instance.Error=TRUE) THEN  
    // Processing after error end  
    Operating:=FALSE;  
END_IF;  
END_IF;
```

NX_SerialSend

The NX_SerialSend instruction sends data in No-protocol Mode from a serial port on an NX-series Communications Interface Unit or Option Board.

Instruction	Name	FB/ FUN	Graphic expression	ST expression
NX_SerialSend	Send No-protocol Data	FB		<pre>NX_SerialSend_instance(Execute, DevicePort, SendDat, SendSize, SendCfg, Option, Abort, Done, Busy, CommandAborted, Error, ErrorID);</pre>



Version Information

A CPU Unit with unit version 1.11 or later and Sysmac Studio version 1.15 or higher are required to use this instruction.

Variables

Name	Meaning	I/O	Description	Valid range	Unit	Default
DevicePort	Device port	Input	Object that represents a device port	---	---	---
SendDat[] (array)	Send data array		Send data array	Depends on data type.	---	*1
SendSize	Send data size		Send data size	0 to 4096	Bytes	0
SendCfg	Conditions attached to send data		Conditions attached to send data	---	---	---
Option	Option		Option	---	---	---
Abort	Interruption		Interruption of instruction execution	Depends on data type.	---	FALSE
Command-Aborted	Interruption completion	Output	Interruption completion	Depends on data type.	---	---

*1 If you omit an input parameter, the default value is not applied. A building error will occur.

	Boolean	Bit strings				Integers							Real numbers		Times, durations, dates, and text strings					
	BOOL	BYTE	WORD	DWORD	LWORD	USINT	UINT	UDINT	ULINT	SINT	INT	DINT	LINT	REAL	LREAL	TIME	DATE	TOD	DT	STRING
DevicePort	Refer to <i>Function</i> for details on the structure <code>_sDEVICE_PORT</code> .																			
SendDat[] (array)	OK																			
SendSize						OK														
SendCfg	Refer to <i>Function</i> for details on the structure <code>_sSERIAL_CFG</code> .																			
Option	Refer to <i>Function</i> for details on the structure <code>_sSERIAL_SEND_OPTION</code> .																			
Abort	OK																			
Command-Aborted	OK																			

Function

The NX_SerialSend instruction sends data in No-protocol Mode from the specified port on an NX-series Communications Interface Unit or Option Board.

The data type of the *DevicePort* input variable is structure `_sDEVICE_PORT`. The specifications are as follows:

Name	Meaning	Description	Data type	Valid range	Unit	Default
DevicePort	Device port	Object that represents a device port	<code>_sDEVICE_PORT</code>	---	---	---
DeviceType	Device type	Type of the device to specify	<code>_eDEVICE_TYPE</code>	<code>_DeviceNXUnit</code> <code>_DeviceEcatSlave</code> <code>_DeviceOptionBoard</code>	---	---
NxUnit	Specified Unit	NX Unit to control	<code>_sNXUNIT_ID</code>	---	---	---
EcatSlave	Specified slave	EtherCAT slave to control	<code>_sECAT_ID</code>	---	---	---
OptBoard	Specified Option Board	Option Board to control	<code>_sOPTBOARD_ID</code>	---	---	---
Reserved	Reserved	Reserved	Reserved	---	---	---
PortNo	Port number	Port number 1: Port 1 2: Port 2	USINT	Depends on data type.	---	---

Use *DeviceType* to specify the device type. Set this to `_DeviceNXUnit` for an NX Unit and `_DeviceOptionBoard` for an Option Board. The variable used to specify the device is determined by the specified device type.

To specify an NX Unit, use *NxUnit* to specify the device.

In this case, *EcatSlave* and *OptBoard* are not used.

To *NxUnit*, pass the device variable that is assigned to the node location information on the I/O Map for the device to specify.

To specify an Option Board, use *OptBoard* to specify the device.

In this case, *NxUnit* and *EcatSlave* are not used.

To *OptBoard*, pass the device variable that is assigned to the node location information on the I/O Map for the device to specify.

If you use this instruction, be sure to assign a device variable to the node location information. Do not assign device variables to any I/O ports following the node location information that are indicated by “W” under the R/W column.

The figure below is an example of using this instruction for port 1 on an NX-CIF210.

Position	Port	Description	R/W	Data Type	Variable
Unit1	NX-CIF210	Node location information	R	_sNXUNIT_ID	N1_Node_location_information
		Ch1 Output SID	W	JSINT	
		Ch1 Input SID Response	W	JSINT	
		Ch1 Output Data Type	W	WORD	
		Ch1 Output Sub Info	W	WORD	
		Ch1 Output Data Length	W	JINT	
		Ch1 Output Data 01	W	ARRAY[0..3] OF BYTE	
		Ch1 Output Data 02	W	ARRAY[0..3] OF BYTE	
		Ch1 Output Data 03	W	ARRAY[0..3] OF BYTE	
		Ch1 Output Data 04	W	ARRAY[0..3] OF BYTE	
		Ch1 Output Data 05	W	ARRAY[0..3] OF BYTE	

Refer to the *Sysmac Studio Version 1 Operation Manual* (Cat. No. W504-E1-07 or later) for details on assigning a device variable to the node location information.

Use *PortNo* to specify the port number.

- 1: Port 1
- 2: Port 2

For an NX Unit, set this to Port 1 or Port 2.

For an Option Board, set this to Port 1.

The data type of *Device Type* is enumerated type `_eDEVICE_TYPE`.

The meanings of the enumerators of enumerated type `_eDEVICE_TYPE` are as follows:

Enumerator	Meaning
<code>_DeviceNXUnit</code>	NX Unit is specified.
<code>_DeviceEcatSlave</code>	EtherCAT slave is specified.
<code>_DeviceOptionBoard</code>	Option Board is specified.

In this instruction, you can specify `_DeviceNXUnit` or `_DeviceOptionBoard`.

Data of the size specified with the *SendSize* input variable is sent from the send data specified with the *SendDat* input variable. If the value of *SendSize* is 0, nothing is sent. When the instruction is executed, the value of *Done* changes to TRUE instead of *Busy*.

To attach start and end codes to the send data, set them in the *SendCfg* input variable.

The data type of the *SendCfg* input variable is structure `_sSERIAL_CFG`. The specifications are as follows:

Name	Meaning	Description	Data type	Valid range	Unit	Default
SendCfg	Conditions attached to send data	Conditions attached to send data	<code>_sSERIAL_CFG</code>	---	---	---
StartTrig	Start code existence	Start code existence	<code>_eSERIAL_START</code>	<code>_SERIAL_START_NONE</code> <code>_SERIAL_START_STARTCODE1</code> <code>_SERIAL_START_STARTCODE2</code>	---	<code>_SERIAL_START_NONE</code>
StartCode	Start code	Start code	BYTE[2]	Depends on data type.	---	[2(16#0)]
EndTrig	End code existence	End code existence	<code>_eSERIAL_END</code>	<code>_SERIAL_END_NONE</code> <code>_SERIAL_END_ENDCODE1</code> <code>_SERIAL_END_ENDCODE2</code> <code>_SERIAL_END_TERMINATION_CHAR</code> <code>_SERIAL_END_RCV_SIZE</code>	---	<code>_SERIAL_END_NONE</code>
EndCode	End code	End code	BYTE[2]	Depends on data type.	---	[2(16#0)]
RcvSizeCfg	Receive size	Not used in this instruction.	UINT	0 to 4096	Bytes	0

The data type of *StartTrig* is enumerated type `_eSERIAL_START`.

The meanings of the enumerators of enumerated type `_eSERIAL_START` are as follows:

Enumerator	Meaning
<code>_SERIAL_START_NONE</code>	None
<code>_SERIAL_START_STARTCODE1</code>	1-byte code
<code>_SERIAL_START_STARTCODE2</code>	2-byte code

The data type of *EndTrig* is enumerated type `_eSERIAL_END`.

The meanings of the enumerators of enumerated type `_eSERIAL_END` are as follows:

Enumerator	Meaning
<code>_SERIAL_END_NONE</code>	None
<code>_SERIAL_END_ENDCODE1</code>	1-byte code
<code>_SERIAL_END_ENDCODE2</code>	2-byte code
<code>_SERIAL_END_TERMINATION_CHAR</code>	Termination condition
<code>_SERIAL_END_RCV_SIZE</code>	Receive size

Refer to *Operation of Start Code and End Code* on page 2-1257 for details on the operation of start code and end code.

To delay data transmission from the Controller to an NX-series Communications Interface Unit, set a delay time in units of 0.01 s with the *Option.SendDelay* input variable. The data type of the *Option* input variable is structure `_sSERIAL_SEND_OPTION`. The specifications are as follows:

Name	Meaning	Description	Data type	Valid range	Unit	Default
Option	Option	Option	<code>_sSERIAL_SEND_OPTION</code>	---	---	---
SendDelay	Send delay time	Send delay time	UINT	Depends on data type.	0.01 s	0

An error occurs if this instruction is executed for Units other than NX-series Communications Interface Units and Option Boards.

Operation of Start Code and End Code

Use *SendCfg.StartTrig* and *SendCfg.EndTrig* to specify the conditions of start and end codes that are attached to the send data.

If you attach a start or end code to the send data, exclude it from the value set for the *SendSize* input variable.

The operations of *StartTrig* and *EndTrig* are given below.

Value of <i>StartTrig</i>	Operation
<code>_SERIAL_START_NONE</code>	---
<code>_SERIAL_START_STARTCODE1</code>	<i>SendDat</i> is sent with start code attached to its beginning. Example: STX
<code>_SERIAL_START_STARTCODE2</code>	

Value of <i>EndTrig</i>	Operation
<code>_SERIAL_END_NONE</code>	---
<code>_SERIAL_END_ENDCODE1</code>	<i>SendDat</i> is sent with end code attached to its end. Example: ETX
<code>_SERIAL_END_ENDCODE2</code>	
<code>_SERIAL_END_TERMINATION_CHAR</code>	Error
<code>_SERIAL_END_RCV_SIZE</code>	Error

Interruption of Instruction Execution

If *Abort* is changed to TRUE during instruction execution, the execution is interrupted.

When the instruction execution is interrupted, *CommandAborted* changes to TRUE. The instruction is interrupted even when the data transmission is in progress.

If the change of *Abort* is too late to interrupt the execution, *Done* changes to TRUE and the instruction ends normally.

If both *Abort* and *Execute* are changed to TRUE, *CommandAborted* changes to TRUE.

The interruption operation only finishes the *Busy* processing, and it does not clear the send buffer. To clear the buffer, use the `NX_SerialBufClear` instruction.

Timing Charts

The following figures show the timing charts.

● Normal end (when *SendDelay* is 0 (0 s))

The operation is as follows when *SendDelay* is 0 (0 s).

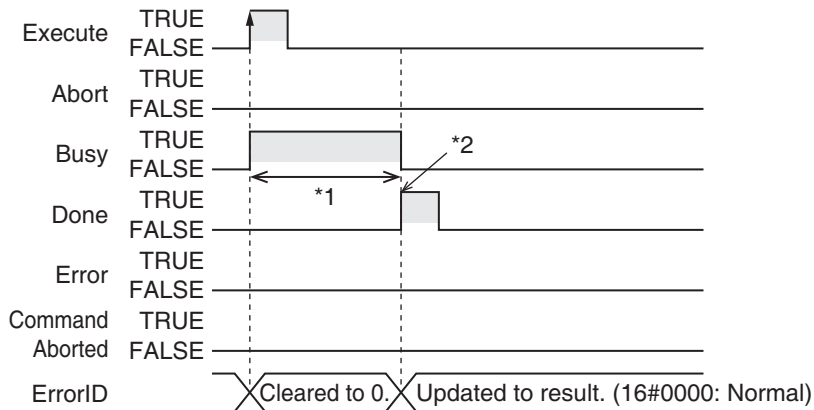

● Normal end (when *SendDelay* is 100 (1 s))

The operation is as follows when *SendDelay* is 100 (1 s).

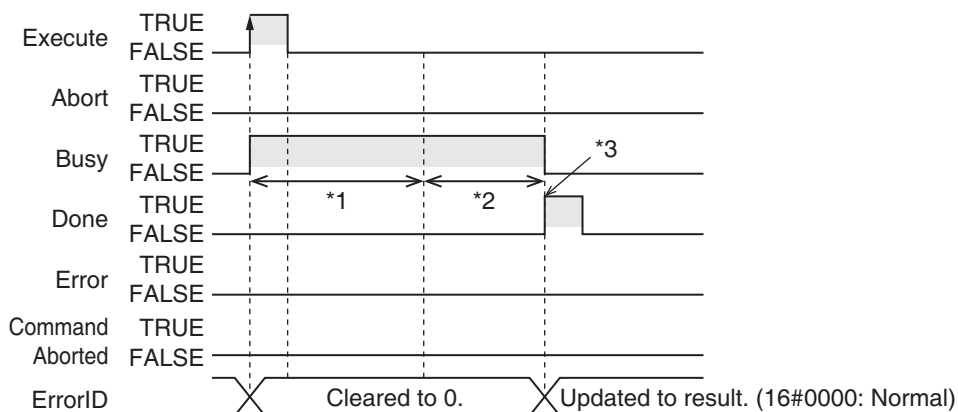

● **Interruption executed (when *Busy* is TRUE)**

The operation is as follows if *Abort* is changed to TRUE while *Busy* is TRUE.

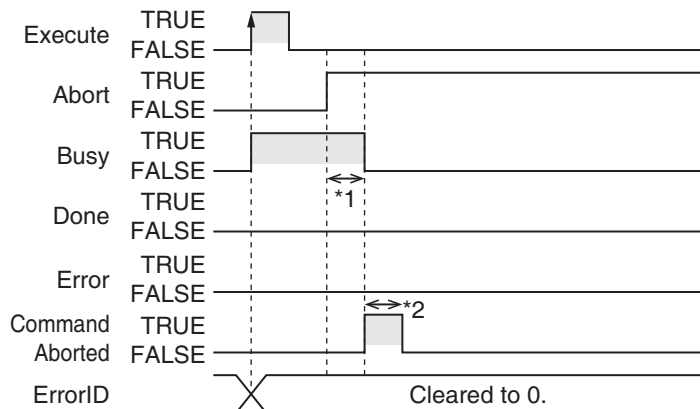

*1 Interruption processing

*2 Changes to FALSE after one task period.

● **Interruption executed (when *Execute* is TRUE)**

The operation is as follows if both *Abort* and *Execute* are changed to TRUE.

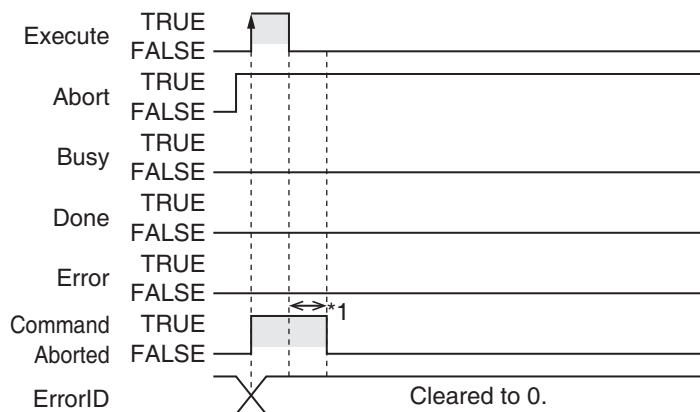

*1 Changes to FALSE after one task period.

Related System-defined Variables

The following device variable name is created automatically for an EtherCAT Coupler Unit whose device name is E001.

Name	Meaning	Data type	Description
_PLC_OptBoardSta	Option Board Status	ARRAY[1..2] of _sOPTBOARD_STA	<ul style="list-style-type: none"> This stores the status of the Option Board.
_NXB_UnitIOActiveTbl	NX Unit I/O Data Active Status	ARRAY[0..8] OF BOOL	<ul style="list-style-type: none"> This status tells the NX Units whether I/O data communications can be processed. The subscript of the array corresponds to the NX Unit numbers. A subscript of 0 means the NX bus master.

Precautions for Correct Use

- When *Abort* remains FALSE, this instruction is executed until the completion of processing even if *Execute* changes to FALSE or the execution time exceeds the task period. The value of *Done* changes to TRUE when processing is completed. Use this to confirm normal completion of processing. If *Abort* is changed to TRUE during instruction execution, *CommandAborted* or *Done* changes to TRUE.
- A compiling error will occur if you use this instruction in an event task. Do not use this instruction in event tasks.
- A CIF Unit Initialized error may occur when the NX-series Communications Interface Unit is restarted. Send or receive the data again, if necessary.
- If you use this instruction, do not assign device variables to any I/O ports that are indicated by "W" under the R/W column on the I/O Map Tab Page in the Sysmac Studio for the applicable NX-series Communications Interface Unit.
- An error will occur in the following cases. *Error* will change to TRUE.
 - A value that is out of range is set for *SendSize*, *SendCfg.StartTrig*, *SendCfg.EndTrig*, *DevicePort.DevicePortType*, or *DevicePort.PortNo*.
 - The array variable specified with *SendDat* is smaller than the size specified with *SendSize*.
 - The Unit, Option Board, or port specified with *DevicePort* does not exist.
 - The data type of *DevicePort* is invalid.
 - If more than 32 instructions from the NX_SerialSend instruction, NX_SerialRcv instruction, NX_ModbusRtuCmd instruction, NX_ModbusRtuRead instruction, NX_ModbusRtuWrite instruction, NX_SerialSigCtl instruction, NX_SerialSigRead instruction, NX_SerialStatusRead instruction, NX_SerialBufClear instruction, NX_SerialStartMon instruction and NX_SerialStopMon instruction are executed at the same time.
 - This instruction is executed with a device port variable that is the same as the one specified for the instruction which is still being executed. In this case, the instruction which is still being executed is one of the followings.
The NX_SerialSend instruction, NX_ModbusRtuCmd instruction, NX_ModbusRtuRead instruction, and NX_ModbusWrite instruction.
 - This instruction is executed for Units other than NX-series Communications Interface Units and Option Boards.
 - The serial communications mode of the specified Option Board is not *No-protocol*.

Sample Programming

In this sample, an NX-series Communications Interface Unit (NX-CIF210) is connected to an EtherCAT Coupler Unit (NX-ECC203).

The unit number of the NX-CIF210 is set to 1.

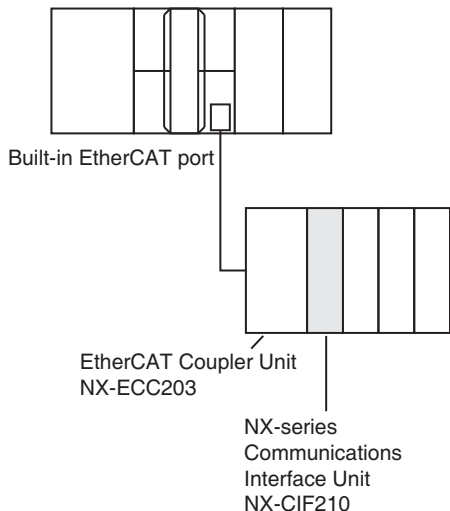

A no-protocol command is sent to the barcode reader that is connected to serial port 2 of the NX-CIF210. The send command is the scene number acquisition command (@READ).

For the send command, the StringToAry instruction is used to separate the text string '@READ' into individual characters and convert them to the character codes. The character codes are stored in the array elements of SendDat[].

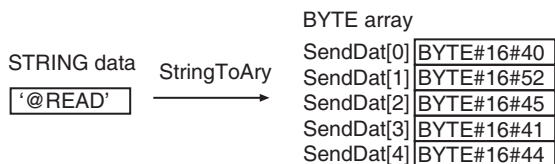

There is no start code. End code is 16#OD (CR).

The settings of NX-CIF210 are given in the following table.

Item	Set value
Port 2: Baud Rate	38,400 bps
Port 2: Data Length	8 bits
Port 2: Parity	None
Port 2: Stop Bits	1 bit
Port 2: Flow Control	None

Definitions of Global Variables

Global Variables

Name	Data type	AT	Comment
E001_NX_Unit_I_O_Data_Active_Status_63	ARRAY[0..63] OF BOOL	ECAT://node#1/NX Unit I/O Data Active Status 125	Usage of I/O data for 63 NX Units.
N1_Node_location_information	_sNXUNIT_ID	---	Device variable to specify NX-CIF210*1

*1 On the Sysmac Studio, right-click an NX-series slave terminal unit, select **Display Node Location Port**, and set the device variable. Refer to the *Sysmac Studio Version 1 Operation Manual* (Cat. No. W504-E1-07 or later) for details.

LD

Internal Variables	Variable	Data type	Initial value	Comment
	OperationEnd	BOOL	FALSE	Processing completed
	Trigger	BOOL	FALSE	Execution condition
	Operating	BOOL	FALSE	Processing
	DevicePort	_sDEVICE_PORT		Port settings
	SendDat	ARRAY [0..5] OF BYTE	[6(16#0)]	Send data
	SendSize	UINT	0	Send data size
	RS_instance	RS		
	NX_SerialSend_instance	NX_SerialSend		
	SendCfg	_sSERIAL_SEND_CFG		
	StartTrig	_eSERIAL_START	_SERIAL_START_NONE	Without start code
	StartCode	BYTE[2]	[2(16#0)]	
	EndTrig	_eSERIAL_END	_SERIAL_END_END-CODE1	With end code
	EndCode	BYTE[2]	[16#0D,16#00]	16#0D(CR)

External Variables	Variable	Data type	Comment
	E001_NX_Unit_I_O_Data_Active_Status_63	ARRAY[0..63] OF BOOL	<ul style="list-style-type: none"> Usage of I/O data for 63 NX Units. If the relevant Unit number is 1, E001_NX_Unit_I_O_Data_Active_Status_63[1] is used.
	N1_Node_location_information	_sNXUNIT_ID	Device variable to specify NX-CIF210

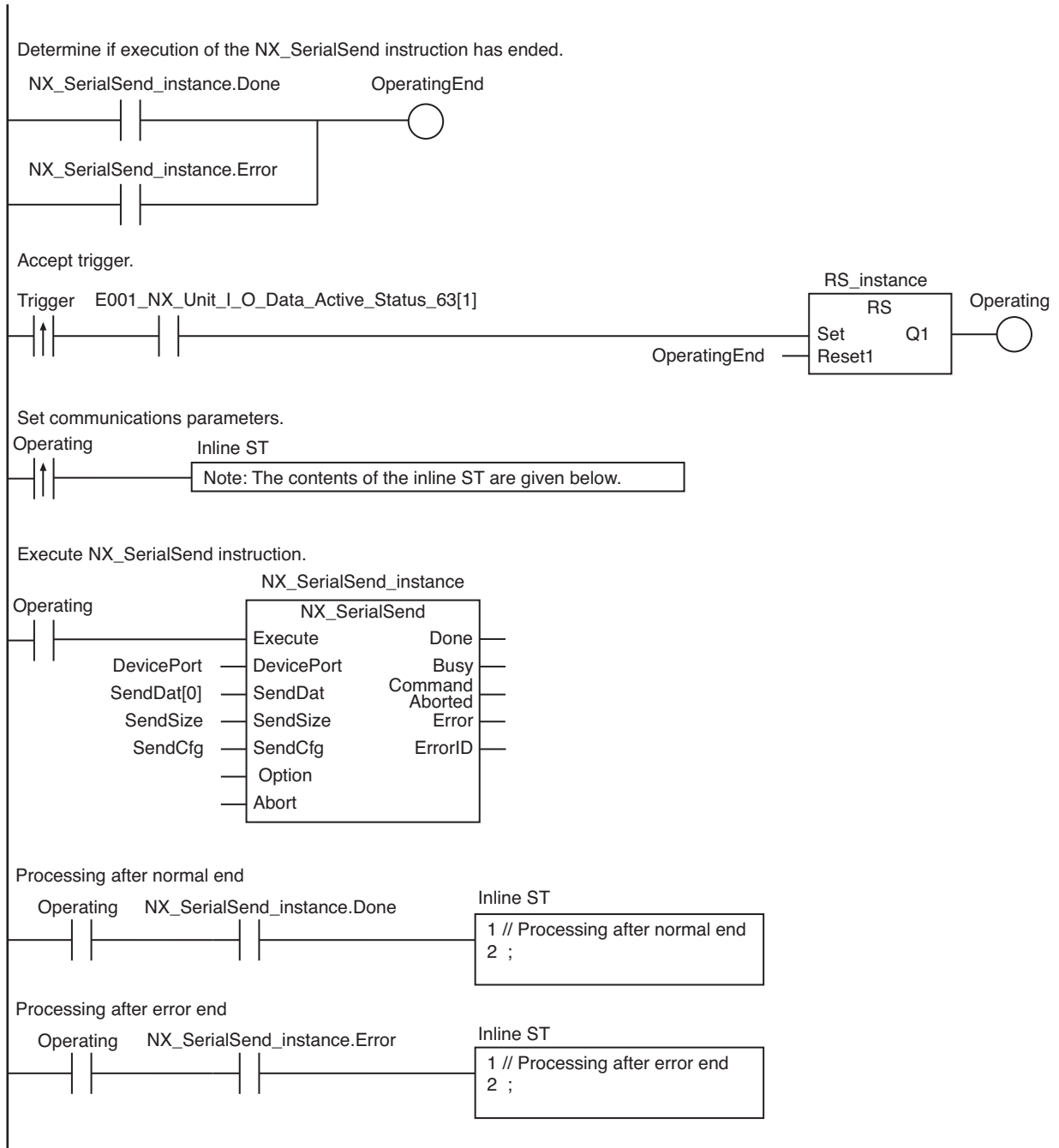

● Contents of Inline ST

```

DevicePort.DeviceType:=_eDEVICE_TYPE#_DeviceNXUnit;
DevicePort.NxUnit:=N1_Node_location_information;
DevicePort.PortNo:=2;
StringToAry(In:='@READ', AryOut:=SendDat[0]);
SendSize := UINT#10#5;
    
```

ST

Internal Variables	Variable	Data type	Initial value	Comment
	Trigger	BOOL	FALSE	Execution condition
	LastTrigger	BOOL	FALSE	Value of Trigger from previous task period
	OperatingStart	BOOL	FALSE	Processing started
	Operating	BOOL	FALSE	Processing
	DevicePort	_sDEVICE_PORT		Port settings
	SendDat	ARRAY [0..5] of BYTE	[6(16#0)]	Send data
	SendSize	UINT	0	Send data size
	NX_SerialSend_instance	NX_SerialSend		
	SendCfg	_sSERIAL_CFG		
	StartTrig	_eSERIAL_START	_SERIAL_START_NONE	Without start code
	StartCode	BYTE[2]	[2(16#0)]	
	EndTrig	_eSERIAL_END	_SERIAL_END_ENDCODE1	With end code
	EndCode	BYTE[2]	[16#0D,16#00]	16#0D(CR)

External Variables	Variable	Data type	Comment
	E001_NX_Unit_I_O_Data_Active_Status_63	ARRAY[0..63] OF BOOL	<ul style="list-style-type: none"> Usage of I/O data for 63 NX Units. If the relevant Unit number is 1, E001_NX_Unit_I_O_Data_Active_Status_63[1] is used.
	N1_Node_location_information	_sNXUNIT_ID	Device variable to specify NX-CIF210

```

// Detect when Trigger changes to TRUE.
IF ( (Trigger=TRUE) AND (LastTrigger=FALSE)
    AND (E001_NX_Unit_I_O_Data_Active_Status_63[1]) AND
    (NX_SerialSend_instance.Busy=FALSE) ) THEN
    OperatingStart:=TRUE;
    Operating:=TRUE;
    DevicePort.DeviceType:=_eDEVICE_TYPE#_DeviceNXUnit;
    DevicePort.NxUnit:=N1_Node_location_information;
    DevicePort.PortNo:=2;
END_IF;
LastTrigger:=Trigger;

// Set communications parameters and initialize NX_SerialSend instruction.
IF (OperatingStart=TRUE) THEN
    NX_SerialSend_instance(
        Execute:=FALSE,
        DevicePort:=DevicePort;
        SendDat:=SendDat [0],
        SendSize:=UINT#1,
        SendCfg:=SendCfg);
    StringToAry(In:='@READ', AryOut:=SendDat [0]);
    SendSize:=UINT#10#5;
    OperatingStart:=FALSE;
END_IF;

// Execute NX_SerialSend instruction.

```

```
IF (Operating=TRUE) THEN
    NX_SerialSend_instance(
        Execute:=TRUE,
        DevicePort:=DevicePort, // Port settings
        SendDat:=SendDat[0],    // Send data
        SendSize:=SendSize,     // Send data size
        SendCfg:=SendCfg);     // End code settings
    IF (NX_SerialSend_instance.Done=TRUE) THEN
        // Processing after normal end

        Operating:=FALSE;
    END_IF;

    IF (NX_SerialSend_instance.Error=TRUE) THEN
        // Processing after error end

        Operating:=FALSE;
    END_IF;
END_IF;
```

NX_SerialRcv

The NX_SerialRcv instruction reads data in No-protocol Mode from a serial port on an NX-series Communications Interface Unit or Option Board.

Instruction	Name	FB/ FUN	Graphic expression	ST expression
NX_SerialRcv	Receive No-protocol Data	FB		<pre>NX_SerialRcv_instance(Execute, DevicePort, RcvDat, Size, RcvCfg, Option, Abort, Done, Busy, CommandAborted, Error, ErrorID, RcvSize);</pre>



Version Information

A CPU Unit with unit version 1.11 or later and Sysmac Studio version 1.15 or higher are required to use this instruction.

Variables

Name	Meaning	I/O	Description	Valid range	Unit	Default
DevicePort	Device port	Input	Object that represents a device port	---	---	---
Size	Storage size		Size of <i>RcvDat</i> in bytes	1 to 4096	Bytes	1
RcvCfg	Reception completion setting		Reception completion setting	---	---	---
Option	Option		Option	---	---	---
Abort	Interruption		Interruption of instruction execution	---	---	FALSE
RcvDat[] (array)	Receive data	In-out	Variable to store data received from the receive buffer	Depends on data type.	---	---
Command-Aborted	Interruption completion	Output	Interruption completion	Depends on data type.	---	---
RcvSize	Receive size		Size of data actually received from the receive buffer	0 to 4096	Bytes	---

	Boolean	Bit strings					Integers							Real numbers		Times, durations, dates, and text strings				
	BOOL	BYTE	WORD	DWORD	LWORD	USINT	UINT	UDINT	ULINT	SINT	INT	DINT	LINT	REAL	LREAL	TIME	DATE	TOD	DT	STRING
DevicePort	Refer to <i>Function</i> for details on the structure <code>_sDEVICE_PORT</code> .																			
Size							OK													
RcvCfg	Refer to <i>Function</i> for details on the structure <code>_sSERIAL_CFG</code> .																			
Option	Refer to <i>Function</i> for details on the structure <code>_sSERIAL_RCV_OPTION</code> .																			
Abort	OK																			
RcvDat[] (array)		OK																		
Command- Aborted	OK																			
RcvSize							OK													

Function

The `NX_SerialRcv` instruction reads data in No-protocol Mode from the specified port on an NX-series Communications Interface Unit or Option Board.

The data type of the `DevicePort` input variable is structure `_sDEVICE_PORT`. The specifications are as follows:

Name	Meaning	Description	Data type	Valid range	Unit	Default
DevicePort	Device port	Object that represents a device port	<code>_sDEVICE_PORT</code>	---	---	---
DeviceType	Device type	Type of the device to specify	<code>_eDEVICE_TYPE</code>	<code>_DeviceNXUnit</code> <code>_DeviceEcatSlave</code> <code>_DeviceOptionBoard</code>	---	---
NxUnit	Specified Unit	NX Unit to control	<code>_sNXUNIT_ID</code>	---	---	---
EcatSlave	Specified slave	EtherCAT slave to control	<code>_sECAT_ID</code>	---	---	---
OptBoard	Specified Option Board	Option Board to control	<code>_sOPTBOARD_ID</code>	---	---	---
Reserved	Reserved	Reserved	Reserved	---	---	---
PortNo	Port number	Port number 1: Port 1 2: Port 2	USINT	Depends on data type.	---	---

Use `DeviceType` to specify the device type. Set this to `_DeviceNXUnit` for an NX Unit and `_DeviceOptionBoard` for an Option Board. The variable used to specify the device is determined by the specified device type.

To specify an NX Unit, use `NxUnit` to specify the device.

In this case, `EcatSlave` and `OptBoard` are not used.

To `NxUnit`, pass the device variable that is assigned to the node location information on the I/O Map for the device to specify.

To specify an Option Board, use *OptBoard* to specify the device.

In this case, *NxUnit* and *EcatSlave* are not used.

To *OptBoard*, pass the device variable that is assigned to the node location information on the I/O Map for the device to specify.

If you use this instruction, be sure to assign a device variable to the node location information. Do not assign device variables to any I/O ports following the node location information that are indicated by “W” under the R/W column.

The figure below is an example of using this instruction for port 1 on an NX-CIF210.

Position	Port	Description	R/W	Data Type	Variable
Unit1	NX-CIF210	Node location information	R	_sNXUNIT_ID	N1_Node_location_information
		Ch1 Output SID	W	USINT	
		Ch1 Input SID Response	W	USINT	
		▶ Ch1 Output Data Type	W	WORD	
		Ch1 Output Sub Info	W	WORD	
		Ch1 Output Data Length	W	UINT	
		▶ Ch1 Output Data 01	W	ARRAY[0..3] OF BYTE	
		Ch1 Output Data 02	W	ARRAY[0..3] OF BYTE	
		▶ Ch1 Output Data 03	W	ARRAY[0..3] OF BYTE	
		▶ Ch1 Output Data 04	W	ARRAY[0..3] OF BYTE	
		▶ Ch1 Output Data 05	W	ARRAY[0..3] OF BYTE	

Refer to the *Sysmac Studio Version 1 Operation Manual* (Cat. No. W504-E1-07 or later) for details on assigning a device variable to the node location information.

Use *PortNo* to specify the port number.

- 1: Port 1
- 2: Port 2

For an NX Unit, set this to Port 1 or Port 2.

For an Option Board, set this to Port 1.

The data type of *DeviceType* is enumerated type `_eDEVICE_TYPE`.

The meanings of the enumerators of enumerated type `_eDEVICE_TYPE` are as follows:

Enumerator	Meaning
<code>_DeviceNXUnit</code>	NX Unit is specified.
<code>_DeviceEcatSlave</code>	EtherCAT slave is specified.
<code>_DeviceOptionBoard</code>	Option Board is specified.

In this instruction, you can specify `_DeviceNXUnit` or `_DeviceOptionBoard`.

First, data received by the Unit is stored in the receive buffer.

Use the *RcvDat* in-out variable to specify the variable to store data received from the receive buffer.

Use the *Size* input variable to set the size of *RcvDat* in bytes.

The *RcvSize* output variable represents the size of data actually received from the receive buffer.

When the receive data includes start or end code, you must set the *RcvCfg* input variable.

The data type of *RcvCfg* input variable is structure `_sSERIAL_CFG`. The specifications are as follows:

Name	Meaning	Description	Data type	Valid range	Unit	Default
RcvCfg	Reception completion setting	Reception completion setting	<code>_sSERIAL_CFG</code>	---	---	---
StartTrig	Start code existence	Start code existence	<code>_eSERIAL_START</code>	<code>_SERIAL_START_NONE</code> <code>_SERIAL_START_STARTCODE1</code> <code>_SERIAL_START_STARTCODE2</code>	---	<code>_SERIAL_START_NONE</code>
StartCode	Start code	Start code	BYTE[2]	Depends on data type.	---	[2(16#0)]
EndTrig	End code existence	End code existence	<code>_eSERIAL_END</code>	<code>_SERIAL_END_NONE</code> <code>_SERIAL_END_ENDCODE1</code> <code>_SERIAL_END_ENDCODE2</code> <code>_SERIAL_END_TERMINATION_CHAR</code> <code>_SERIAL_END_RCV_SIZE</code>	---	<code>_SERIAL_END_NONE</code>
EndCode	End code	End code	BYTE[2]	Depends on data type.	---	[2(16#0)]
RcvSizeCfg	Receive size	Receive size specified when end code is <code>_SERIAL_END_RCV_SIZE</code>	UINT	0 to 4,096	Bytes	0

The data type of *StartTrig* is enumerated type `_eSERIAL_START`.

The meanings of the enumerators of enumerated type `_eSERIAL_START` are as follows:

Enumerator	Meaning
<code>_SERIAL_START_NONE</code>	None
<code>_SERIAL_START_STARTCODE1</code>	1-byte code
<code>_SERIAL_START_STARTCODE2</code>	2-byte code

The data type of *EndTrig* is enumerated type `_eSERIAL_END`.

The meanings of the enumerators of enumerated type `_eSERIAL_END` are as follows:

Enumerator	Meaning
<code>_SERIAL_END_NONE</code>	None
<code>_SERIAL_END_ENDCODE1</code>	1-byte code
<code>_SERIAL_END_ENDCODE2</code>	2-byte code
<code>_SERIAL_END_TERMINATION_CHAR</code>	Termination condition
<code>_SERIAL_END_RCV_SIZE</code>	Receive size

Refer to *Operation of Start Code and End Code* on page 2-1257 for details on the operation of start code and end code.

To set options, use the *Option* input variable.

The data type of the *Option* input variable is structure `_eSERIAL_RCV_OPTION`. The specifications are as follows:

Name	Meaning	Description	Data type	Valid range	Unit	Default
Option	Option	Option	<code>_sSERIAL_RCV_OPTION</code>	---	---	---
TimeOut*1	Timeout time	Timeout time	UINT	Depends on data type.	0.1 s	20
LastDatRcv (Reserved)	Last data reception	Last data reception	BOOL	FALSE *2	---	FALSE
ClearBuf	Receive buffer clear condition	Receive buffer clear condition	BOOL	Depends on data type.	---	FALSE

*1 An error occurs if the processing does not ends normally within the specified time.
If *TimeOut* is set to 0, the completion of processing will be waited indefinitely.

*2 Always set the value to FALSE.

An error occurs if this instruction is executed for Units other than NX-series Communications Interface Units and Option Boards.

Operation of Start Code and End Code

Use the *RcvCfg.StartTrig* input variable to set the start code condition for the receive data, and use the *RcvCfg.EndTrig* input variable to set the end code condition for the receive data.

The following table shows operation based on combination of *StartTrig* and *EndTrig*.

StartTrig	EndTrig	Operation
<code>_SERIAL_START_NONE</code>	<code>_SERIAL_END_NONE</code>	Data in the receive buffer is received. If there is no receive data in the receive buffer, 0 byte is output to the <i>RcvSize</i> output variable and the receive instruction ends normally. If this condition is set, the data of the storage size that is remaining in the receive buffer is read.
	<code>_SERIAL_END_ENDCODE1</code> <code>_SERIAL_END_ENDCODE2</code>	The following range of data is received from the receive buffer: from the beginning to the end code. Example: ETX
	<code>_SERIAL_END_TERMINATION_CHAR</code>	The following range of data is received from the receive buffer: from the beginning to the data detected as the end. *1
	<code>_SERIAL_END_RCV_SIZE</code>	The following range of data is received from the receive buffer: from the beginning to the receive size specified in <i>RcvSizeCfg</i> . Processing is performed only after the specified amount of data is accumulated in the buffer.

StartTrig	EndTrig	Operation
_SERIAL_START_STARTCODE1 _SERIAL_START_STARTCODE2	_SERIAL_END_NONE	The following range of data is received from the receive buffer: from the start code to the end of data.
	_SERIAL_END_ENDCODE1	The following range of data is received from the receive buffer: from the start code to the end code. Example: ETX
	_SERIAL_END_ENDCODE2	
	_SERIAL_END_TERMINATION_CHAR	The following range of data is received from the receive buffer: from the start code to the data detected as the end. *1
	_SERIAL_END_RCV_SIZE	The following range of data is received from the receive buffer: from the start code to the receive size specified in <i>Rcv-Size</i> . Processing is performed only after the specified amount of data is accumulated in the buffer.

*1 If the number of characters detected as the end of data in the Communications Interface Unit is set to 0 (Do not detect the end), reception will continue until the data of the storage size specified in the *Size* input variable is received.



Precautions for Correct Use

If `_SERIAL_END_TERMINATION_CHAR` is selected when an Option Board is specified, an error will occur.

Operation When Receive Data Storage Is Insufficient

If the receive data storage specified in the *Size* input variable is smaller than the received data, operation is performed according to the combination of start and end codes, as shown below.

StartTrig	EndTrig	Operation
_SERIAL_START_NONE	_SERIAL_END_NONE	Normal end
	_SERIAL_END_ENDCODE1	Error end, but data is received. Example: ETX
	_SERIAL_END_ENDCODE2	
	_SERIAL_END_TERMINATION_CHAR	Error end, but data is received.*1
	_SERIAL_END_RCV_SIZE	<ul style="list-style-type: none"> • Error end for an input value check error • Data cannot be received.
_SERIAL_START_STARTCODE1 _SERIAL_START_STARTCODE2	_SERIAL_END_NONE	Error end, but data is received.
	_SERIAL_END_ENDCODE1	Error end, but data is received. Example: ETX
	_SERIAL_END_ENDCODE2	
	_SERIAL_END_TERMINATION_CHAR	Error end, but data is received.*1
	_SERIAL_END_RCV_SIZE	<ul style="list-style-type: none"> • Error end for an input value check error • Data cannot be received.

*1 An error occurs if an Option Board is specified.

Data of the size of the storage *RcvDat* is received and the rest of data is retained in the receive buffer. The retained data can be received when the next *SerialRcv* instruction is executed.

For example, when 10-byte data exists in the receive buffer and the capacity of the receive data storage *RcvDat* is 5 bytes, 5-byte data is received and other 5-byte data is retained in the receive buffer. The value of the *RcvSize* output variable will be 5 bytes, which represents the size of data that is stored.

Receive buffer		Receive data storage <i>RcvDat</i> []
1st byte	Receive processing is performed.	1
2nd byte		2
3rd byte		3
4th byte		4
5th byte		5
6th byte	Cannot be stored in <i>RcvDat</i> . Data is retained in the receive buffer.	---
7th byte		
8th byte	Receive processing for the data is performed when the next <i>NX_SerialRcv</i> instruction is executed.	
9th byte		
10th byte		

Interruption of Instruction Execution

If *Abort* is changed to TRUE during instruction execution, the execution is interrupted.

When the instruction execution is interrupted, *CommandAborted* changes to TRUE.

If the change of *Abort* is too late to interrupt the execution, *Done* changes to TRUE and the instruction ends normally.

If both *Abort* and *Execute* are changed to TRUE, *CommandAborted* changes to TRUE.

This interruption operation only finishes the *Busy* processing, and it does not clear the receive buffer. To clear the buffer, use the *NX_SerialBufClear* instruction.

Timing Charts

The following figures show the timing charts.

● Normal end

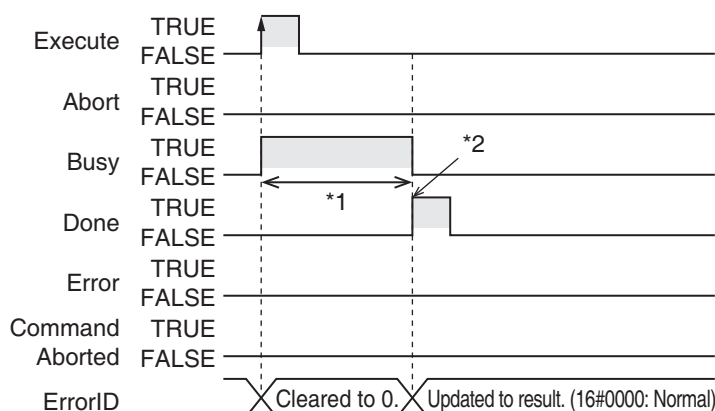

*1 Receive processing

*2 Data is received in No-protocol mode.

● **Interruption executed (when *Busy* is TRUE)**

The operation is as follows if *Abort* is changed to TRUE while *Busy* is TRUE.

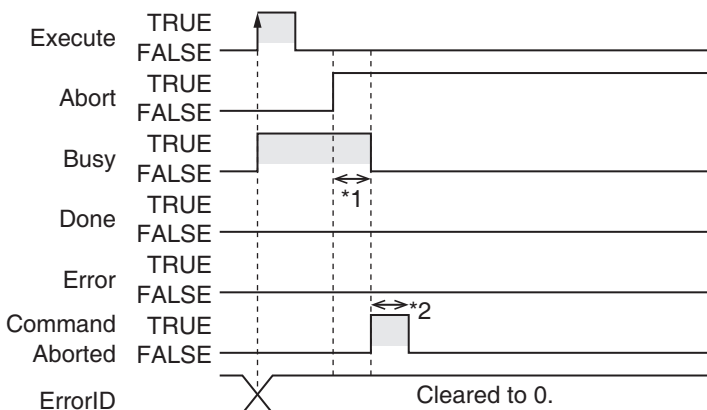

*1 Interruption processing

*2 Changes to FALSE after one task period.

● **Interruption executed (when *Execute* is TRUE)**

The operation is as follows if both *Abort* and *Execute* are changed to TRUE.

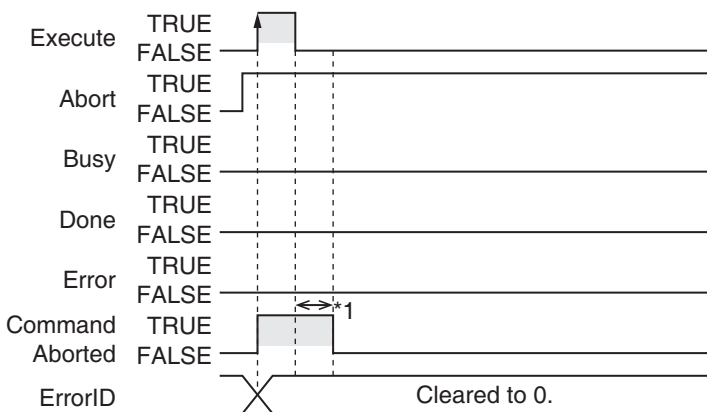

*1 Changes to FALSE after one task period.

Related System-defined Variables

Name	Meaning	Data type	Description
_PLC_OptBoardSta	Option Board Status	ARRAY[1..2] of _sOPTBOARD_STA	<ul style="list-style-type: none"> This stores the status of the Option Board.
_NXB_UnitIOActiveTbl	NX Unit I/O Data Active Status	ARRAY[0..8] OF BOOL	<ul style="list-style-type: none"> This status tells the NX Units whether I/O data communications can be processed. The subscript of the array corresponds to the NX Unit numbers. A subscript of 0 means the NX bus master.

Precautions for Correct Use

- When *Abort* remains FALSE, this instruction is executed until the completion of processing even if *Execute* changes to FALSE or the execution time exceeds the task period. The value of *Done* changes to TRUE when processing is completed. Use this to confirm normal completion of processing. If *Abort* is changed to TRUE during instruction execution, *CommandAborted* or *Done* changes to TRUE.
- Data is not received when *RcvCfg.EndTrig* is `_SERIAL_END_RCV_SIZE` and the value of the *RcvCfg.RcvSizeCfg* input variable is 0. In this case, the value of *Done* changes to TRUE at instruction execution.
- A compiling error will occur if you use this instruction in an event task. Do not use this instruction in event tasks.
- A CIF Unit Initialized error may occur when the NX-series Communications Interface Unit is restarted. Send or receive the data again, if necessary.
- If you use this instruction, do not assign device variables to any I/O ports that are indicated by "W" under the R/W column on the I/O Map Tab Page in the Sysmac Studio for the applicable NX-series Communications Interface Unit.
- An error will occur in the following cases. *Error* will change to TRUE.
 - A value that is out of range is set for *RcvCfg.RcvSizeCfg* while *RcvCfg.EndTrig* is set to `_SERIAL_END_RCV_SIZE`.
 - A value that is out of range is set for *Size*, *DevicePort.DevicePortType* or *DevicePort.PortNo*.
 - *Option.LastDatRcv* is TRUE.
 - The array variable specified with the *RcvDat* in-out variable is smaller than the size specified with the *Size* input variable.
 - The storage size that is specified by *Size* for saving the data in *RcvDat* is smaller than the actually received data.
 - The Unit, Option Board, or port specified with *DevicePort* does not exist.
 - The data type of *DevicePort* is invalid.
 - `_SERIAL_END_TERMINATION_CHAR` is selected with *RcvCfg.EndTrig* when an Option Board is specified with *DevicePort*.
 - If more than 32 instructions from the `NX_SerialSend` instruction, `NX_SerialRcv` instruction, `NX_ModbusRtuCmd` instruction, `NX_ModbusRtuRead` instruction, `NX_ModbusRtuWrite` instruction, `NX_SerialSigCtl` instruction, `NX_SerialSigRead` instruction, `NX_SerialStatusRead` instruction, `NX_SerialBufClear` instruction, `NX_SerialStartMon` instruction and `NX_SerialStopMon` instruction are executed at the same time.
 - The receive buffer is full.
 - This instruction is executed with a device port variable that is the same as the one specified for the instruction which is still being executed. In this case, the instruction which is still being executed is one of the followings. The `NX_SerialRcv` instruction, `NX_ModbusRtuCmd` instruction, `NX_ModbusRtuRead` instruction, and `NX_ModbusRtuWrite` instruction.
 - A parity error occurred in the data received.
 - A framing error occurred in the data received.
 - An overrun error occurred in the data received.
 - Timeout time elapsed.
 - This instruction is executed for Units other than NX-series Communications Interface Units and Option Boards.
 - The serial communications mode of the specified Option Board is not *No-protocol*.

Sample Programming

In this sample, an NX-series Communications Interface Unit (NX-CIF210) is connected to an EtherCAT Coupler Unit (NX-ECC203).

The unit number of the NX-CIF210 is set to 1.

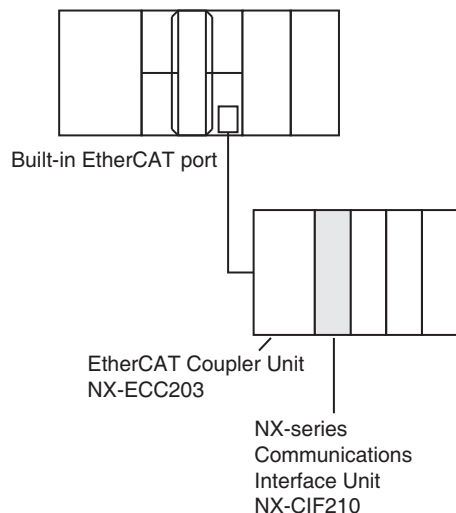

Data that was read by the barcode reader which is connected to serial port 2 of the NX-CIF210 is obtained.

The receive data is stored in the *RecvDat* in-out variable. There is no start code. End code is 16#OD (CR).

The settings of NX-CIF210 are given in the following table.

Item	Set value
Port 2: Baud Rate	38,400 bps
Port 2: Data Length	8 bits
Port 2: Parity	None
Port 2: Stop Bits	1 bit
Port 2: Flow Control	None

Definitions of Global Variables

Global Variables

Name	Data type	AT	Comment
E001_NX_Unit_I_O_Data_Active_Status_63	ARRAY[0..63] OF BOOL	ECAT://node#1/NX Unit I/O Data Active Status 125	Usage of I/O data for 63 NX Units.
N1_Node_location_information	_sNXUNIT_ID	---	Device variable to specify NX-CIF210*1

*1 On the Sysmac Studio, right-click an NX-series slave terminal unit, select **Display Node Location Port**, and set the device variable. Refer to the *Sysmac Studio Version 1 Operation Manual* (Cat. No. W504-E1-07 or later) for details.

LD

Internal Variables	Variable	Data type	Initial value	Comment
	OperationEnd	BOOL	FALSE	Processing completed
	Trigger	BOOL	FALSE	Execution condition
	Operating	BOOL	FALSE	Processing
	DevicePort	_sDEVICE_PORT		Port settings
	RecvDat	ARRAY [0..255] of BYTE	[256(16#0)]	Receive data
	RecvSize	UINT	0	Receive data size
	RecvStringDat	STRING[257]	"	
	Code	ULINT	0	Barcode (integer)
	RS_instance	RS		
	NX_Serial-Rcv_instance	NX_SerialRcv		
	RcvCfg	_sSERIAL_CFG		Reception completion setting
	StartTrig	_eSERIAL_START	_SERIAL_START_NONE	Without start code
	StartCode	BYTE[2]	[2(16#0)]	
	EndTrig	_eSERIAL_END	_SERIAL_END_ENDCODE1	With end code
	EndCode	BYTE[2]	[16#0D,16#00]	16#0D(CR)
	RcvSizeCfg	UINT	0	
	Option	_sSERIAL_RCV_OPTION		Option
	TimeOut	TIME	TIME#0s	
	LastDatRcv	BOOL	FALSE	

External Variables	Variable	Data type	Comment
	E001_NX_Unit_I_O_Data_Active_Status_63	ARRAY[0..63] OF BOOL	<ul style="list-style-type: none"> Usage of I/O data for 63 NX Units. If the relevant Unit number is 1, E001_NX_Unit_I_O_Data_Active_Status_63[1] is used.
	N1_Node_location_information	_sNXUNIT_ID	Device variable to specify NX-CIF210

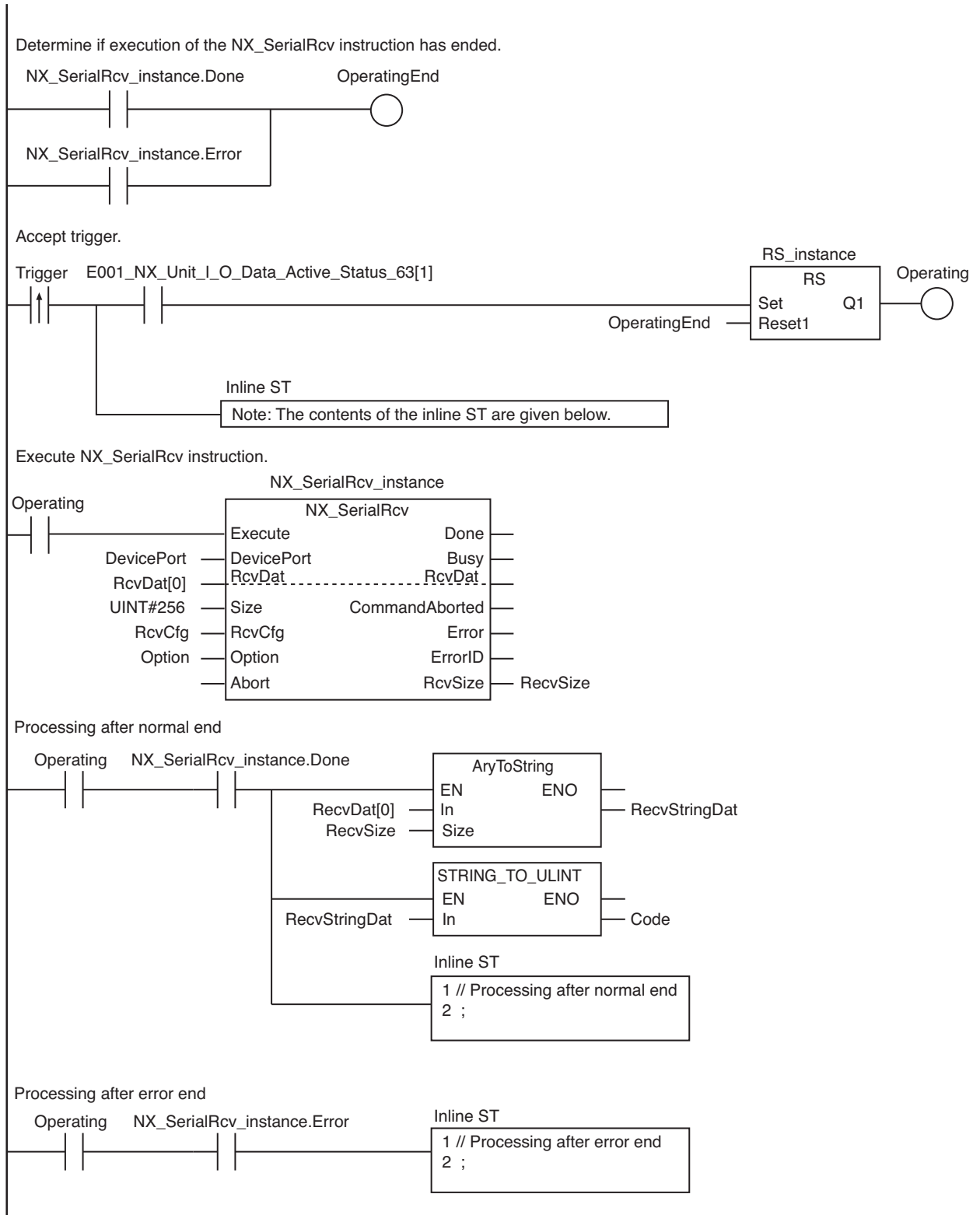

● Contents of Inline ST

```

DevicePort.DeviceType:=_eDEVICE_TYPE#_DeviceNXUnit;
DevicePort.NxUnit:=N1_Node_location_information;
DevicePort.PortNo:=2;
    
```

ST

Internal Variables	Variable	Data type	Initial value	Comment
	Trigger	BOOL	FALSE	Execution condition
	LastTrigger	BOOL	FALSE	Value of Trigger from previous task period
	OperatingStart	BOOL	FALSE	Processing started
	Operating	BOOL	FALSE	Processing
	DevicePort	_sDEVICE_PORT		Port settings
	RecvDat	ARRAY [0..255] of BYTE	[256(16#0)]	Receive data
	RecvSize	UINT	0	Receive data size
	RecvStringDat	STRING[257]	"	
	Code	ULINT	0	Barcode (integer)
	NX_SerialRcv_instance	NX_SerialRcv		
	RcvCfg	_sSERIAL_CFG		Reception completion setting
	StartTrig	_eSERIAL_START	_SERIAL_START_NONE	Without start code
	StartCode	BYTE[2]	[2(16#0)]	
	EndTrig	_eSERIAL_END	_SERIAL_END_END-CODE1	With end code
	EndCode	BYTE[2]	[16#0D,16#00]	16#0D(CR)
	RcvSizeCfg	UINT	0	
	Option	_sSERIAL_RCV_OPTION		Option
	TimeOut	TIME	TIME#0s	
	LastDatRcv	BOOL	FALSE	

External Variables	Variable	Data type	Comment
	E001_NX_Unit_I_O_Data_Active_Status_63	ARRAY[0..63] OF BOOL	<ul style="list-style-type: none"> Usage of I/O data for 63 NX Units. If the relevant Unit number is 1, E001_NX_Unit_I_O_Data_Active_Status_63[1] is used.
	N1_Node_location_information	_sNXUNIT_ID	Device variable to specify NX-CIF210

```
// Detect when Trigger changes to TRUE.
IF ( (Trigger=TRUE) AND (LastTrigger=FALSE)
    AND(E001_NX_Unit_I_O_Data_Active_Status_63[1]) AND (SerialRcv_instance.Busy=FALSE) ) THEN
    OperatingStart:=TRUE;
    Operating:=TRUE;
    DevicePort.DeviceType:=_eDEVICE_TYPE#_DeviceNXUnit;
    DevicePort.NxUnit:=N1_Node_location_information;
    DevicePort.Port.PortNo:=2;
END_IF;
LastTrigger:=Trigger;

// Set communications parameters and initialize SerialRcv instruction.
```

```

IF (OperatingStart=TRUE) THEN
    NX_SerialRcv_instance(
        Execute:=FALSE,           // Initialize instance.
        DevicePort:=DevicePort, // Port settings
        Size:=UINT#256,,         // Receive data size
        RcvDat:=RcvDat,          // Receive data
        RcvSize=>RcvSize);       // Data size that was actu-
ally received
    OperatingStart:=FALSE;
END_IF;
// Execute NX_SerialRcv instruction.
IF (Operating=TRUE) THEN
    NX_SerialRcv_instance(
        Execute:=TRUE,
        DevicePort:=DevicePort,
        Size:=UINT#256,
        RcvDat:=RcvDat,
        RcvSize=>RcvSize);
    IF (NX_SerialRcv_instance.Done=TRUE) THEN
        // Processing after normal end
        RcvStringDat:=AryToString(In:=RcvDat[0],Size:=RcvSize); // Con-
vert character codes to a text string.
        Code:=STRING_TO_ULINT(RcvDat); // Convert text string to an inte-
ger.

        Operating:=FALSE;
    END_IF;
    IF (NX_SerialRcv_instance.Error=TRUE) THEN
        // Processing after error end
        Operating:=FALSE;
    END_IF;
END_IF;

```

NX_ModbusRtuCmd

The NX_ModbusRtuCmd instruction sends general commands from a serial port on an NX-series Communications Interface Unit or Option Board to Modbus-RTU slaves using Modbus-RTU protocol.

Instruction	Name	FB/ FUN	Graphic expression	ST expression
NX_ModbusRtuCmd	Send Modbus RTU General Command	FB		<pre>NX_ModbusRtuCmd_instance(Execute, DevicePort, SlaveAdr, CmdDat, CmdSize, RespDat, Option, Abort, Done, Busy, CommandAborted, Error, ErrorID, ErrorIDEx, RespSize);</pre>



Version Information

A CPU Unit with unit version 1.11 or later and Sysmac Studio version 1.15 or higher are required to use this instruction.

Variables

Name	Meaning	I/O	Description	Valid range	Unit	Default
DevicePort	Device port	Input	Object that represents a device port	---	---	---
SlaveAdr	Slave address		Address of Modbus-RTU slave*1	0 to 247	---	1
CmdDat[] (array)	Command data		Command data	Depends on data type.	---	*2
CmdSize	Command data size		Command data size	1 to 253	Bytes	*2*3
Option	Option		Option	---	---	---
Abort	Interruption		Interruption of instruction execution	Depends on data type.	---	FALSE
RespDat[] (array)	Read data	In-out	Variable that stores read data	Depends on data type.	---	---
Command-Aborted	Interruption completion	Output	Interruption completion	Depends on data type.	---	---
RespSize	Receive size		Receive data size	1 to 253	Bytes	*4

*1 If 0 is set, you can broadcast commands to Modbus-RTU slaves.

- *2 If you omit an input parameter, the default value is not applied. A building error will occur.
- *3 Set the total number of bytes for the function code and command data. The number of bytes for the function code is one.
- *4 The total number of bytes for the function code and read data is stored. The number of bytes for the function code is one.

	Boolean	Bit strings					Integers							Real numbers		Times, durations, dates, and text strings				
	BOOL	BYTE	WORD	DWORD	LWORD	USINT	UINT	UDINT	ULINT	SINT	INT	DINT	LINT	REAL	LREAL	TIME	DATE	TOD	DT	STRING
DevicePort	Refer to <i>Function</i> for details on the structure <code>_sDEVICE_PORT</code> .																			
SlaveAdr							OK													
CmdDat[] (array)		OK																		
CmdSize							OK													
Option	Refer to <i>Function</i> for details on the structure <code>_sSERIAL_MODBUSRTU_OPTION</code> .																			
Abort	OK																			
Resp-Dat[]array		OK																		
Command-Aborted	OK																			
RespSize							OK													

Function

The `NX_ModbusRtuCmd` instruction sends general commands from a serial port on an NX-series Communications Interface Unit or Option Board to Modbus-RTU slaves using Modbus-RTU protocol.

This instruction ends normally when a normal response to the sent command is received.

When a command is broadcasted, this instruction ends normally without waiting for responses from slaves.

The data type of the *DevicePort* input variable is structure `_sDEVICE_PORT`. The specifications are as follows:

Name	Meaning	Description	Data type	Valid range	Unit	Default
DevicePort	Device port	Object that represents a device port	<code>_sDEVICE_PORT</code>	---	---	---
DeviceType	Device type	Type of the device to specify	<code>_eDEVICE_TYPE</code>	<code>_DeviceNXUnit</code> <code>_DeviceEcat-Slave</code> <code>_DeviceOption-Board</code>	---	---
NxUnit	Specified Unit	NX Unit to control	<code>_sNXUNIT_ID</code>	---	---	---
EcatSlave	Specified slave	EtherCAT slave to control	<code>_sECAT_ID</code>	---	---	---
OptBoard	Specified Option Board	Option Board to control	<code>_sOPTBOARD_ID</code>	---	---	---
Reserved	Reserved	Reserved	Reserved	---	---	---
PortNo	Port number	Port number 1: Port 1 2: Port 2	USINT	Depends on data type.	---	---

Use *DeviceType* to specify the device type. Set this to `_DeviceNXUnit` for an NX Unit and `_DeviceOptionBoard` for an Option Board. The variable used to specify the device is determined by the specified device type.

To specify an NX Unit, use *NxUnit* to specify the device.

In this case, *EcatSlave* and *OptBoard* are not used.

To *NxUnit*, pass the device variable that is assigned to the node location information on the I/O Map for the device to specify.

To specify an Option Board, use *OptBoard* to specify the device.

In this case, *NxUnit* and *EcatSlave* are not used.

To *OptBoard*, pass the device variable that is assigned to the node location information on the I/O Map for the device to specify.

If you use this instruction, be sure to assign a device variable to the node location information. Do not assign device variables to any I/O ports following the node location information that are indicated by “W” under the R/W column.

The figure below is an example of using this instruction for port 1 on an NX-CIF210.

Position	Port	Description	R/W	Data Type	Variable
Unit1	▼ NX-CIF210				
	Node location information	Node location information	R	_sNXUNIT_ID	N1_Node_location_information
	⋮				
	Ch1 Output SID	Ch1 Output SID	W	USINT	
	Ch1 Input SID Response	Ch1 Input SID Response	W	USINT	
	▶ Ch1 Output Data Type	Ch1 Output Data Type	W	WORD	
	Ch1 Output Sub Info	Ch1 Output Sub Info	W	WORD	
	Ch1 Output Data Length	Ch1 Output Data Length	W	UINT	
	▶ Ch1 Output Data 01	Ch1 Output Data 01	W	ARRAY[0..3] OF BYTE	
	▶ Ch1 Output Data 02	Ch1 Output Data 02	W	ARRAY[0..3] OF BYTE	
	▶ Ch1 Output Data 03	Ch1 Output Data 03	W	ARRAY[0..3] OF BYTE	
	▶ Ch1 Output Data 04	Ch1 Output Data 04	W	ARRAY[0..3] OF BYTE	
	▶ Ch1 Output Data 05	Ch1 Output Data 05	W	ARRAY[0..3] OF BYTE	

Refer to the *Sysmac Studio Version 1 Operation Manual* (Cat. No. W504-E1-07 or later) for details on assigning a device variable to the node location information.

Use *PortNo* to specify the port number.

1: Port 1

2: Port 2

For an NX Unit, set this to Port 1 or Port 2.

For an Option Board, set this to Port 1.

The data type of *DeviceType* is enumerated type `_eDEVICE_TYPE`.

The meanings of the enumerators of enumerated type `_eDEVICE_TYPE` are as follows:

Enumerator	Meaning
<code>_DeviceNXUnit</code>	NX Unit is specified.
<code>_DeviceEcatSlave</code>	EtherCAT slave is specified.
<code>_DeviceOptionBoard</code>	Option Board is specified.

In this instruction, you can specify `_DeviceNXUnit` or `_DeviceOptionBoard`.

Use the *SlaveAdr* input variable to specify the address of a Modbus-RTU slave.

To broadcast commands to Modbus-RTU slaves, set the *SlaveAdr* input variable to 0.

Set the command data with the *CmdDat* input variable, and set the size of command data with the *CmdSize* input variable.

CRC is attached by the instruction.

Use the *RespDat* in-out variable to specify the variable to store the read data.

The *RespSize* output variable represents the size of received data.

To set options, use the *Option* input variable.

The data type of the *Option* input variable is structure `_sSERIAL_MODBUSRTU_OPTION`. The specifications are as follows:

Name	Meaning	Description	Data type	Valid range	Unit	Default
Option	Option	Option	<code>_sSERIAL_MODBUSRTU_OPTION</code>	---	---	---
SendDelay	Send delay time	Send delay time in units of 0.01 s	UINT	Depends on data type.	0.01 s	0
TimeOut	Timeout time	2.0 s when the timeout time is set to 0	UINT	Depends on data type.	0.1 s	20
NoResponse	No response	<ul style="list-style-type: none"> Set TRUE when no response is waited for the send command. If TRUE is set, this instruction sends a command and ends normally without waiting for the elapse of the timeout time. 	BOOL	Depends on data type.	---	FALSE
Retry	Retry count	Retry count	USINT	0 to 15	---	0

An error occurs if this instruction is executed for Units other than NX-series Communications Interface Units and Option Boards.

Interruption of Instruction Execution

If *Abort* is changed to TRUE during instruction execution, the execution is interrupted.

When the instruction execution is interrupted, *CommandAborted* changes to TRUE.

If the change of *Abort* is too late to interrupt the execution, *Done* changes to TRUE and the instruction ends normally.

If both *Abort* and *Execute* are changed to TRUE, *CommandAborted* changes to TRUE.

This interruption operation only finishes the *Busy* processing, and it does not clear the send or receive buffer. To clear the buffer, use the `NX_SerialBufClear` instruction.

Timing Charts

The following figures show the timing charts.

● Normal end (when *SendDelay* is 0 (0 s))

The operation is as follows when *SendDelay* is 0 (0 s).

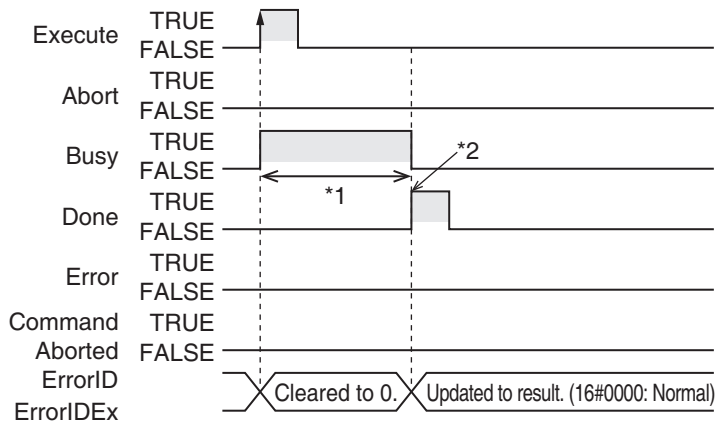

*1 Processing with Modbus-RTU slave

*2 A response to the command is received.

● Normal end (when *SendDelay* is 100 (1 s))

The operation is as follows when *SendDelay* is 100 (1 s).

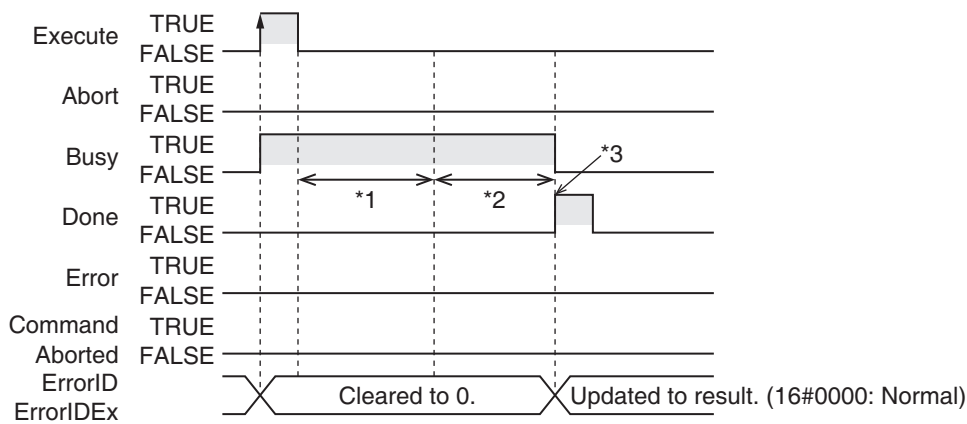

*1 The send delay time of 1 s

*2 A command is sent to a Modbus-RTU slave, and a response is received from the Modbus-RTU slave.

*3 A response to the command is received.

● **Interruption executed (when *Busy* is TRUE)**

The operation is as follows if *Abort* is changed to TRUE while *Busy* is TRUE.

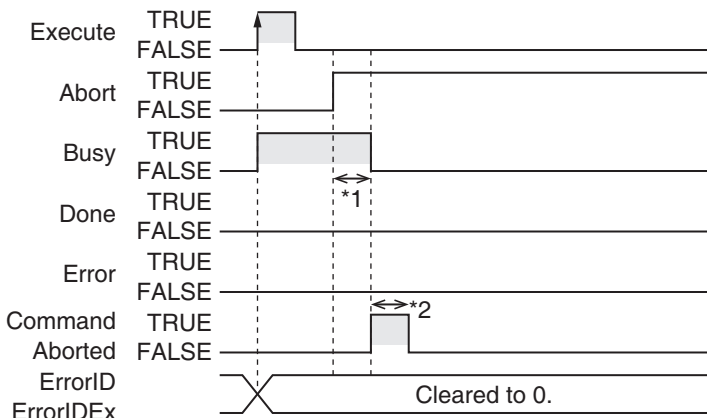

*1 Interruption processing

*2 Changes to FALSE after one task period.

● **Interruption executed (when *Execute* is TRUE)**

The operation is as follows if both *Abort* and *Execute* are changed to TRUE.

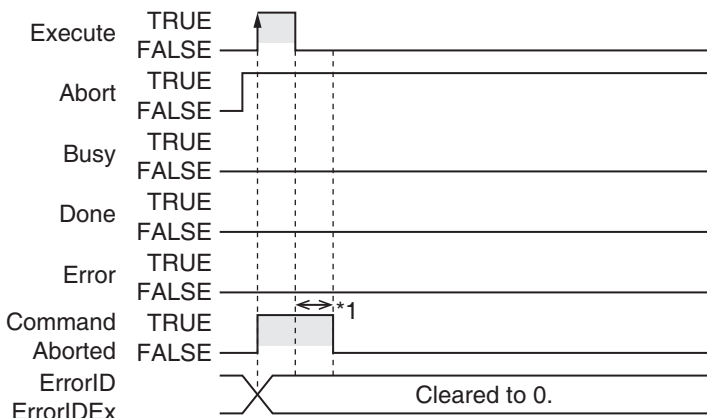

*1 Changes to FALSE after one task period.

Related System-defined Variables

Name	Meaning	Data type	Description
_PLC_OptBoardSta	Option Board Status	ARRAY[1..2] of _sOPTBOARD_STA	<ul style="list-style-type: none"> This stores the status of the Option Board.
_NXB_UnitIOActiveTbl	NX Unit I/O Data Active Status	ARRAY[0..8] OF BOOL	<ul style="list-style-type: none"> This status tells the NX Units whether I/O data communications can be processed. The subscript of the array corresponds to the NX Unit numbers. A subscript of 0 means the NX bus master.

Additional Information

The frame format used in Modbus-RTU mode is as follows.

Slaves Address	Function Code	Data	CRC
1 byte	1 byte	0 to 252 bytes	2 bytes*

* In CRC code, the low byte comes first, and the high byte comes second.

Refer to the *MODBUS Application Protocol Specification* for the specifications of the MODBUS communications protocol.

You can obtain *MODBUS Application Protocol Specification* from Modbus Organization, Inc.

<http://www.modbus.org/>

Precautions for Correct Use

- Execution of this instruction is continued until processing is completed even if the value of *Execute* changes to FALSE or the execution time exceeds the task period. The value of *Done* changes to TRUE when processing is completed. Use this to confirm normal completion of processing. If *Abort* is changed to TRUE during instruction execution, *CommandAborted* or *Done* changes to TRUE.
- A compiling error will occur if you use this instruction in an event task. Do not use this instruction in event tasks.
- A CIF Unit Initialized error may occur when the NX-series Communications Interface Unit is restarted. Send or receive the data again, if necessary.
- If you use this instruction, do not assign device variables to any I/O ports that are indicated by “W” under the R/W column on the I/O Map Tab Page in the Sysmac Studio for the applicable NX-series Communications Interface Unit.
- Data may still remain in the buffer of the target device port in the following cases. To clear the buffer, execute the NX_SerialBufClear instruction before executing the following instruction: NX_ModbusRtuCmd instruction, NX_ModbusRtuRead instruction, or NX_ModbusRtuWrite instruction.
 - After the operation starts or when you change the operating mode to RUN mode.
 - The retry was set (i.e., *Option.Retry* is not 0) in the previous instruction execution.
 - The previous instruction execution is interrupted (i.e., the *CommandAborted* output variable is TRUE).
 - An error occurred (i.e., *Error* is TRUE) in the previous instruction execution.
- An error will occur in the following cases. *Error* will change to TRUE.
 - A value that is out of range was set for *CmdSize*, *Option.Retry*, *DevicePort.DevicePortType*, *DevicePort.PortNo*, or *SlaveAdr*.
 - The variable specified with *CmdDat* is smaller than the size specified with *CmdSize*.
 - The size of the received data is larger than the size of the variable set in *RespDat*.
 - The Unit or port specified with *DevicePort* does not exist.
 - The data type of *DevicePort* is invalid.
 - If more than 32 instructions from the NX_SerialSend instruction, NX_SerialRcv instruction, NX_ModbusRtuCmd instruction, NX_ModbusRtuRead instruction, NX_ModbusRtuWrite instruction, NX_SerialSigCtl instruction, NX_SerialSigRead instruction, NX_SerialStatusRead instruction, NX_SerialBufClear instruction, NX_SerialStartMon instruction and NX_SerialStopMon instruction are executed at the same time.
 - This instruction is executed with a device port variable that is the same as the one specified for the instruction which is still being executed. In this case, the instruction which is still being executed is one of the followings.
The NX_SerialSend instruction, NX_SerialRcv instruction, NX_ModbusRtuCmd instruction, NX_ModbusRtuRead instruction, and NX_ModbusRtuWrite instruction.
 - A parity error occurred in the data received.

- A framing error occurred in the data received.
 - An overrun error occurred in the data received.
 - CRC mismatch occurred for the received data.
 - Timeout time elapsed.
 - This instruction is executed for Units other than NX-series Communications Interface Units and Option Boards.
 - An Exception Response was received from a Modbus-RTU slave. You can check Exception Codes with the *ErrorIDEx* output variable.
 - There was an invalid function code, receive size, etc. in the response data from a Modbus-RTU slave.
 - The serial communications mode of the specified Option Board is not *Modbus-RTU master*.
- In this instruction, the expansion error code *ErrorIDEx* is displayed when an error is detected in a Modbus-RTU slave. An expansion error code is output to *ErrorIDEx* when the value of error code *ErrorID* is WORD#16#0C10. The display format is ErrorIDEx=000000XX. For the value XX, refer to the Exception Code specifications of the MODBUS communications protocol. Refer to the *MODBUS Application Protocol Specification* for the Exception Code specifications of the MODBUS communications protocol. You can obtain *MODBUS Application Protocol Specification* from Modbus Organization, Inc. <http://www.modbus.org/>

Sample Programming

In this sample, an NX-series Communications Interface Unit (NX-CIF210) is connected to an EtherCAT Coupler Unit (NX-ECC203).

The unit number of the NX-CIF210 is set to 1.

For the Unit operation settings of the NX-CIF210, set **Ch2 Number of Characters to Determine the End** to 35. The number of characters is regarded as 3.5 during operation because the unit for setting the Number of Characters to Determine the End is 0.1 character.

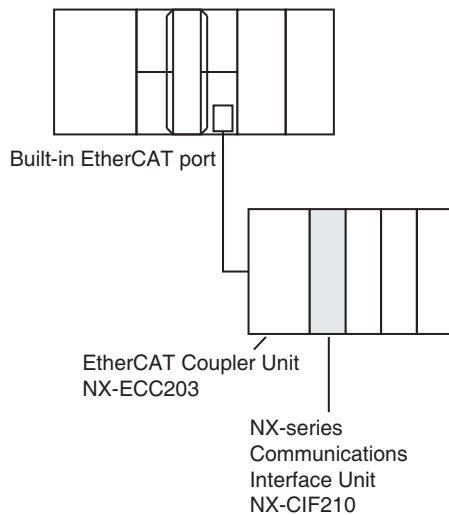

A Modbus-RTU command is sent from serial port 2 of the NX-CIF210.

When *ModbusCmdRequestTrigger* turns ON, a holding register starting from address 32 (BYTE#16#0020) in slave address 1 is read.

General commands are sent/received to read a variable.

Internal Variables	Variable	Data type	Initial value	Comment
	NX_ModbusRtuCmd_instance	NX_ModbusRtuCmd		
	ModbusCmdDat	ARRAY[0..19] OF BYTE	[6(16#0)]	MODBUS command data
	ModbusDatSize	UINT	UINT#0	MODBUS command data total size (byte)
	Done	BOOL	BOOL#FALSE	
	Busy	BOOL	BOOL#FALSE	
	ModbusStage	INT	INT#0	MODBUS communications status
	RspSize	UINT	UINT#0	Actually received data size (byte)
	RespDat	ARRAY[0..275] OF BYTE	[6(16#0)]	Received data storage area
	Error	BOOL		
	ErrorID	WORD		

Internal Variables	Variable	Data type	Initial value	Comment
	ModbusCmdRequestTrigger	BOOL	FALSE	Execution condition
	SlaveAdr	UINT	UINT#0	Slave address
	DevicePort	_sDEVICE_PORT		Port settings

```

IF ( (ModbusCmdRequestTrigger=TRUE)
    AND (ModbusStage=INT#0) ) THEN
    SlaveAdr := 1; // Slave address
    ModbusCmdDat[1]:=BYTE#16#03; // Function code (read variable)
    ModbusCmdDat[2]:=BYTE#16#00; // Reading start address (H)
    ModbusCmdDat[3]:=BYTE#16#20; // Reading start address (L)
    ModbusCmdDat[4]:=BYTE#16#00; // Number of data (H)
    ModbusCmdDat[5]:=BYTE#16#01; // Number of data (L)
    ModbusDatSize:=5;
    ModbusStage:=1;
    DevicePort.DeviceType:=_eDEVICE_TYPE#_DeviceNXUnit;
    DevicePort.NxUnit:=N1_Node_location_information;
    DevicePort.PortNo:=2;
END_IF

// General command sending/receiving
NX_ModbusRtuCmd_instance( Execute:=ModbusCmdRequestTrigger,
    DevicePort:=DevicePort,
    SlaveAdr:=SlaveAdr,
    CmdDat:=ModbusCmdDat[1],
    CmdSize:=ModbusDatSize,
    RespDat:=RspDat[0],
    Done=>Done,
    Busy=>Busy,
    Error=>Error,
    ErrorID=>ErrorID,
    RespSize=>RespSize);

IF ModbusStage=1 THEN
    ModbusCmdRequestTrigger:=FALSE;
    // Error occurred.
    IF (Error<>FALSE) THEN
        ModbusStage:=0;
    ELSE
        ModbusStage:=2;
    END_IF;
ELSIF (ModbusStage=2) THEN
    // Reception completed.
    IF (Error=FALSE) AND (Done=TRUE) THEN
        // Received command interpretation

        ModbusStage:=0;

        // Reception processing in progress
        ELSIF (Busy=TRUE) THEN

        // Reception failed.
        ELSE

            ModbusStage:=0;
        END_IF;
    END_IF;
END_IF;

```

NX_ModbusRtuRead

The NX_ModbusRtuRead instruction sends read commands from a serial port on an NX-series Communications Interface Unit or Option Board to Modbus-RTU slaves using Modbus-RTU protocol.

Instruction	Name	FB/ FUN	Graphic expression	ST expression
NX_ModbusRtuRead	Send Modbus RTU Read Command	FB		<pre>NX_ModbusRtuRead_instance(Execute, DevicePort, SlaveAdr, ReadCmd, ReadDat, Option, Abort, Done, Busy, CommandAborted, Error, ErrorID, ErrorIDEx, ReadSize);</pre>



Version Information

A CPU Unit with unit version 1.11 or later and Sysmac Studio version 1.15 or higher are required to use this instruction.

Variables

Name	Meaning	I/O	Description	Valid range	Unit	Default
DevicePort	Device port	Input	Object that represents a device port	---	---	---
SlaveAdr	Slave address		Address of Modbus-RTU slave*1	1 to 247	---	1
ReadCmd	Read command		Read command	---	---	*2
Option	Option		Option	---	---	---
Abort	Interruption		Interruption of instruction execution	Depends on data type.	---	FALSE
ReadDat[] (array)	Read data	In-out	Variable that stores read data	Depends on data type.	---	---
Command-Aborted	Interruption completion	Output	Interruption completion	Depends on data type.	---	---
ReadSize	Receive size		Receive data size	1 to 2,000*3	---*4	---

*1 An error occurs if 0 is set.

*2 If you omit an input parameter, the default value is not applied. A building error will occur.

*3 If receive data is WORD data, the upper limit value is 125.

*4 The unit is the same as the unit of read data specified with *ReadCmd.Fun*.

	Boolean	Bit strings					Integers						Real numbers		Times, durations, dates, and text strings					
	BOOL	BYTE	WORD	DWORD	LWORD	USINT	UINT	UDINT	ULINT	SINT	INT	DINT	LINT	REAL	LREAL	TIME	DATE	TOD	DT	STRING
DevicePort	Refer to <i>Function</i> for details on the structure <code>_sDEVICE_PORT</code> .																			
SlaveAdr							OK													
ReadCmd	Refer to <i>Function</i> for details on the structure <code>_sSERIAL_MODBUSRTU_READ</code> .																			
Option	Refer to <i>Function</i> for details on the structure <code>_sSERIAL_MODBUSRTU_OPTION</code> .																			
Abort	OK																			
ReadDat[] (array)	OK		OK																	
	An array can also be specified.																			
Command-Aborted	OK																			
ReadSize							OK													

Function

The `NX_ModbusRtuRead` instruction sends read commands from a serial port on an NX-series Communications Interface Unit or Option Board to Modbus-RTU slaves using Modbus-RTU protocol. The requested data is read from the Modbus-RTU slaves.

This instruction ends normally when a normal response to the sent command is received.

The data type of the `DevicePort` input variable is structure `_sDEVICE_PORT`. The specifications are as follows:

Name	Meaning	Description	Data type	Valid range	Unit	Default
DevicePort	Device port	Object that represents a device port	<code>_sDEVICE_PORT</code>	---	---	---
DeviceType	Device type	Type of the device to specify	<code>_eDEVICE_TYPE</code>	<code>_DeviceNXUnit</code> <code>_DeviceEcatSlave</code> <code>_DeviceOptionBoard</code>	---	---
NxUnit	Specified Unit	NX Unit to control	<code>_sNXUNIT_ID</code>	---	---	---
EcatSlave	Specified slave	EtherCAT slave to control	<code>_sECAT_ID</code>	---	---	---
OptBoard	Specified Option Board	Option Board to control	<code>_sOPTBOARD_ID</code>	---	---	---
Reserved	Reserved	Reserved	Reserved	---	---	---
PortNo	Port number	Port number 1: Port 1 2: Port 2	USINT	Depends on data type.	---	---

Use `DeviceType` to specify the device type. Set this to `_DeviceNXUnit` for an NX Unit and `_DeviceOptionBoard` for an Option Board. The variable used to specify the device is determined by the specified device type.

To specify an NX Unit, use `NxUnit` to specify the device.

In this case, `EcatSlave` and `OptBoard` are not used.

To *NxUnit*, pass the device variable that is assigned to the node location information on the I/O Map for the device to specify.

To specify an Option Board, use *OptBoard* to specify the device.

In this case, *NxUnit* and *EcatSlave* are not used.

To *OptBoard*, pass the device variable that is assigned to the node location information on the I/O Map for the device to specify.

If you use this instruction, be sure to assign a device variable to the node location information. Do not assign device variables to any I/O ports following the node location information that are indicated by “W” under the R/W column.

The figure below is an example of using this instruction for port 1 on an NX-CIF210.

Position	Port	Description	R/W	Data Type	Variable
Unit1	▼ NX-CIF210	Node location information	R	_sNXUNIT_ID	N1_Node_location_information
		...			
		Ch1 Output SID	W	USINT	
		Ch1 Input SID Response	W	USINT	
		▶ Ch1 Output Data Type	W	WORD	
		Ch1 Output Sub Info	W	WORD	
		Ch1 Output Data Length	W	UINT	
		▶ Ch1 Output Data 01	W	ARRAY[0..3] OF BYTE	
		▶ Ch1 Output Data 02	W	ARRAY[0..3] OF BYTE	
		▶ Ch1 Output Data 03	W	ARRAY[0..3] OF BYTE	
		▶ Ch1 Output Data 04	W	ARRAY[0..3] OF BYTE	
		▶ Ch1 Output Data 05	W	ARRAY[0..3] OF BYTE	

Refer to the *Sysmac Studio Version 1 Operation Manual* (Cat. No. W504-E1-07 or later) for details on assigning a device variable to the node location information.

Use *PortNo* to specify the port number.

- 1: Port 1
- 2: Port 2

For an NX Unit, set this to Port 1 or Port 2.

For an Option Board, set this to Port 1.

The data type of *DeviceType* is enumerated type *_eDEVICE_TYPE*.

The meanings of the enumerators of enumerated type *_eDEVICE_TYPE* are as follows:

Enumerator	Meaning
_DeviceNXUnit	NX Unit is specified.
_DeviceEcatSlave	EtherCAT slave is specified.
_DeviceOptionBoard	Option Board is specified.

In this instruction, you can specify *_DeviceNXUnit* or *_DeviceOptionBoard*.

Use the *SlaveAdr* input variable to specify the address of a Modbus-RTU slave.

If 0 is set for the *SlaveAdr* input variable, an error occurs and you cannot broadcast commands to Modbus-RTU slaves.

Use the *ReadCmd* input variable to specify the read command.

CRC is attached by the instruction.

The data type of *ReadCmd* input variable is structure `_sSERIAL_MODBUSRTU_READ`. The specifications are as follows:

Name	Meaning	Description	Data type	Valid range	Unit	Default
ReadCmd	Read command	Read command	<code>_sSERIAL_MODBUSRTU_READ</code>	---	---	---
Fun	Function code	Function code	<code>_eMDB_FUN</code>	<code>_MDB_READ_COILS</code> <code>_MDB_READ_DISCRETE_INPUTS</code> <code>_MDB_READ_HOLDING_REGISTERS</code> <code>_MDB_READ_INPUT_REGISTERS</code>	---	<code>_MDB_READ_COILS</code>
ReadAdr	Read address	Read start address	UINT	Depends on data type.	---	0
ReadSize	Read size	Read size	UINT	Depends on function code.	---*1	<code>_MDB_READ_COILS</code>

*1 The unit is the same as the unit of read data specified with *ReadCmd.Fun*.

The data type of *Fun* is enumerated type `_eMDB_FUN`.

The meanings of the enumerators of enumerated type `_eMDB_FUN` are as follows:

Enumerator	Meaning
<code>_MDB_READ_COILS</code>	Read outputs (bit)
<code>_MDB_READ_DISCRETE_INPUTS</code>	Read inputs (bit)
<code>_MDB_READ_HOLDING_REGISTERS</code>	Read holding registers (word)
<code>_MDB_READ_INPUT_REGISTERS</code>	Read input registers (word)

The valid range that you can specify with *ReadSize* varies depending on the function code.

Each value is determined by the size of data that is read and the maximum command length.

The specifications are as follows:

Function code	ReadSize
<code>_MDB_READ_COILS</code>	1 to 2,000 (bit)
<code>_MDB_READ_DISCRETE_INPUTS</code>	1 to 2,000 (bit)
<code>_MDB_READ_HOLDING_REGISTERS</code>	1 to 125 (word)
<code>_MDB_READ_INPUT_REGISTERS</code>	1 to 125 (word)

Use the *ReadDat* in-out variable to specify the variable to store the read data.

The data type that you can use for *ReadDat* differs depending on the function code.

The specifications are as follows:

Function code	Data type
_MDB_READ_COILS	BOOL BOOL[]
_MDB_READ_DISCRETE_INPUTS	BOOL BOOL[]
_MDB_READ_HOLDING_REGISTERS	WORD WORD[]
_MDB_READ_INPUT_REGISTERS	WORD WORD[]

The *ReadSize* output variable represents the size of data that was read.

To set options, use the *Option* input variable.

The data type of the *Option* input variable is structure `_sSERIAL_MODBUSRTU_OPTION`. The specifications are as follows:

Name	Meaning	Description	Data type	Valid range	Unit	Default
Option	Option	Option	<code>_sSERIAL_MODBUSRTU_OPTION</code>	---	---	---
SendDelay	Send delay time	Send delay time	UINT	Depends on data type.	0.01 s	0
TimeOut	Timeout time	2.0 s when the timeout time is set to 0	UINT	Depends on data type.	0.1 s	20
NoResponse	No response	Not used in this instruction.	BOOL	Depends on data type.	---	FALSE
Retry	Retry count	Retry count	USINT	0 to 15	---	0

An error occurs if this instruction is executed for Units other than NX-series Communications Interface Units and Option Boards.

Interruption of Instruction Execution

If *Abort* is changed to TRUE during instruction execution, the execution is interrupted.

When the instruction execution is interrupted, *CommandAborted* changes to TRUE.

If the change of *Abort* is too late to interrupt the execution, *Done* changes to TRUE and the instruction ends normally.

If both *Abort* and *Execute* are changed to TRUE, *CommandAborted* changes to TRUE.

This interruption operation only finishes the *Busy* processing for the instruction, and it does not clear the send or receive buffer. To clear the buffer, use the `NX_SerialBufClear` instruction.

Timing Charts

The following figures show the timing charts.

● Normal end (when *SendDelay* is 0 (0 s))

The operation is as follows when *SendDelay* is 0 (0 s).

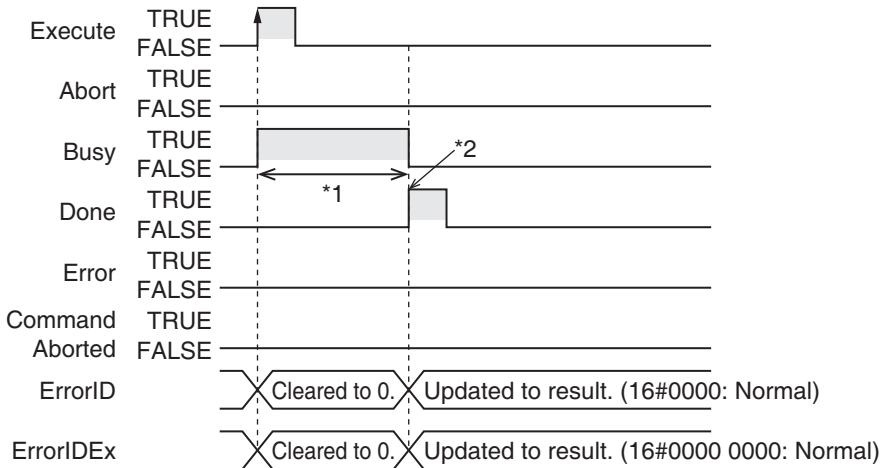

*1 Processing with Modbus-RTU slave

*2 A response to the command is received.

● Normal end (when *SendDelay* is 100 (1 s))

The operation is as follows when *SendDelay* is 100 (1 s).

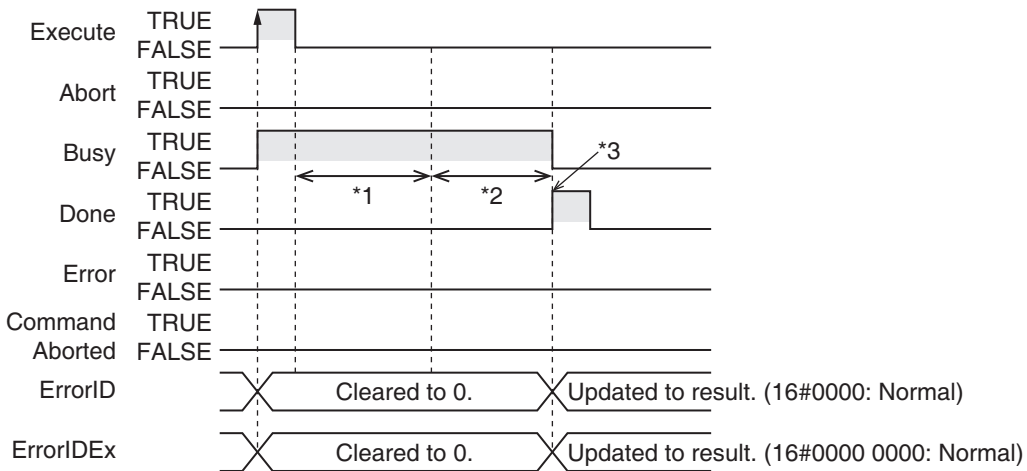

*1 The send delay time of 1 s

*2 A read command is sent to Modbus-RTU slave, and a response is received from Modbus-RTU slave.

*3 A response to the command is received.

● Interruption executed (when *Busy* is TRUE)

The operation is as follows if *Abort* is changed to TRUE while *Busy* is TRUE.

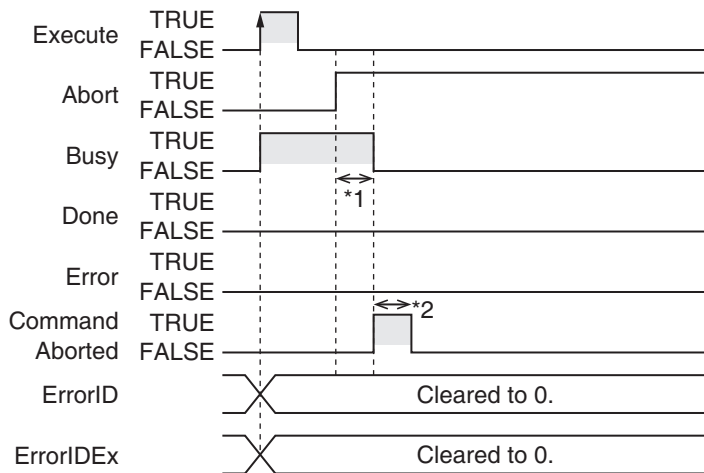

*1 Interruption processing

*2 Changes to FALSE after one task period.

● Interruption executed (when *Execute* is TRUE)

The operation is as follows if both *Abort* and *Execute* are changed to TRUE.

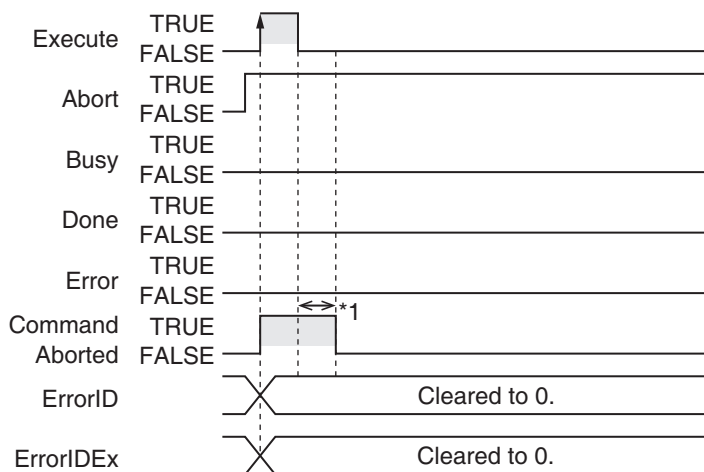

*1 Changes to FALSE after one task period.

Related System-defined Variables

Name	Meaning	Data type	Description
_PLC_OptBoardSta	Option Board Status	ARRAY[1..2] of _sOPTBOARD_STA	<ul style="list-style-type: none"> This stores the status of the Option Board.
_NXB_UnitIOActiveTbl	NX Unit I/O Data Active Status	ARRAY[0..8] OF BOOL	<ul style="list-style-type: none"> This status tells the NX Units whether I/O data communications can be processed. The subscript of the array corresponds to the NX Unit numbers. A subscript of 0 means the NX bus master.

Additional Information

Refer to the *MODBUS Application Protocol Specification* for the specifications of the MODBUS communications protocol.

You can obtain *MODBUS Application Protocol Specification* from Modbus Organization, Inc.

<http://www.modbus.org/>

Precautions for Correct Use

- Execution of this instruction is continued until processing is completed even if the value of *Execute* changes to FALSE or the execution time exceeds the task period. The value of *Done* changes to TRUE when processing is completed. Use this to confirm normal completion of processing. If *Abort* is changed to TRUE during instruction execution, *CommandAborted* or *Done* changes to TRUE.
- A compiling error will occur if you use this instruction in an event task. Do not use this instruction in event tasks.
- A CIF Unit Initialized error may occur when the NX-series Communications Interface Unit is restarted. Send or receive the data again, if necessary.
- If you use this instruction, do not assign device variables to any I/O ports that are indicated by “W” under the R/W column on the I/O Map Tab Page in the Sysmac Studio for the applicable NX-series Communications Interface Unit.
- Data may still remain in the buffer of the target device port in the following cases. To clear the buffer, execute the *NX_SerialBufClear* instruction before executing the following instruction: *NX_ModbusRtuCmd* instruction, *NX_ModbusRtuRead* instruction, or *NX_ModbusRtuWrite* instruction.
 - After the operation starts or when you change the operating mode to RUN mode.
 - The retry was set (i.e., *Option.Retry* is not 0) in the previous instruction execution.
 - The previous instruction execution is interrupted (i.e., the *CommandAborted* output variable is TRUE).
 - An error occurred (i.e., *Error* is TRUE) in the previous instruction execution.
- An error will occur in the following cases. *Error* will change to TRUE.
 - A value that is out of range was set for *SlaveAdr*, *ReadCmd.ReadSize*, *ReadCmd.Fun*, *Option.Retry*, *DevicePort.DevicePortType*, or *DevicePort.PortNo*.
 - The variable specified with *ReadDat* is smaller than the size specified with *ReadCmd.ReadSize*.
 - The Unit or port specified with *DevicePort* does not exist.
 - The data type of *DevicePort* or *RespDat* is invalid.
 - If more than 32 instructions from the *NX_SerialSend* instruction, *NX_SerialRcv* instruction, *NX_ModbusRtuCmd* instruction, *NX_ModbusRtuRead* instruction, *NX_ModbusRtuWrite* instruction, *NX_SerialSigCtl* instruction, *NX_SerialSigRead* instruction, *NX_SerialStatusRead* instruction, *NX_SerialBufClear* instruction, *NX_SerialStartMon* instruction and *NX_SerialStopMon* instruction are executed at the same time.
 - This instruction is executed with a device port variable that is the same as the one specified for the instruction which is still being executed. In this case, the instruction which is still being executed is one of the followings.
The *NX_SerialSend* instruction, *NX_SerialRcv* instruction, *NX_ModbusRtuCmd* instruction, *NX_ModbusRtuRead* instruction, and *NX_ModbusRtuWrite* instruction.
 - A parity error occurred in the data received.
 - A framing error occurred in the data received.
 - An overrun error occurred in the data received.
 - CRC mismatch occurred for the received data.
 - Timeout time elapsed. (When the retry is set, timeout time is multiplied by the number of retries.)
 - This instruction is executed for Units other than NX-series Communications Interface Units and Option Boards.

- An Exception Response was received from a Modbus-RTU slave. You can check Exception Codes with the *ErrorIDEx* output variable.
- There was an invalid function code, receive size, etc. in the response data from a Modbus-RTU slave.
- The serial communications mode of the specified Option Board is not *Modbus-RTU master*.
- In this instruction, the expansion error code *ErrorIDEx* is displayed when an error is detected in a Modbus-RTU slave. An expansion error code is output to *ErrorIDEx* when the value of error code *ErrorID* is WORD#16#0C10. The display format is ErrorIDEx=000000XX. For the value XX, refer to the Exception Code specifications of the MODBUS communications protocol. Refer to the *MODBUS Application Protocol Specification* for the Exception Code specifications of the MODBUS communications protocol. You can obtain *MODBUS Application Protocol Specification* from Modbus Organization, Inc. <http://www.modbus.org/>

Sample Programming

In this sample, an NX-series Communications Interface Unit (NX-CIF210) is connected to an EtherCAT Coupler Unit (NX-ECC203).

The unit number of the NX-CIF210 is set to 1.

For the Unit operation settings of the NX-CIF210, set **Ch2 Number of Characters to Determine the End** to 35. The number of characters is regarded as 3.5 during operation because the unit for setting the Number of Characters to Determine the End is 0.1 character.

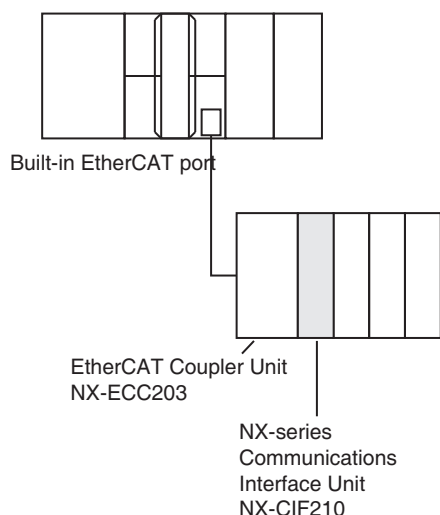

A Modbus-RTU command is sent from serial port 2 of the NX-CIF210.

When *ModbusCmdRequestTrigger* turns ON, the status of an output starting from address 19 in slave address 1 is read.

A read command is sent to read a variable.

Internal Variables	Variable	Data type	Initial value	Comment
	NX_ModbusRtuRead_instance	NX_ModbusRtuRead		
	Done	BOOL		
	Busy	BOOL		
	ModbusStage	INT	INT#0	MODBUS communications status
	Error	BOOL		
	ErrorID	WORD		
	ModbusCmdRequestTrigger	BOOL	FALSE	Execution condition
	SlaveAdr	UINT	UINT#0	Slave address
	DevicePort	_sDEVICE_PORT		Port settings
	ReadCmd	_sSERIAL_MODBUS-RTU_READ		
	ReadDat	BOOL	[6(16#0)]	
	ReadSize	UINT	UINT#0	

```
IF ( (ModbusCmdRequestTrigger=TRUE)
    AND (ModbusStage=INT#0) ) THEN
```

```

        SlaveAdr:=1;
        ReadCmd.FUN:=_MDB_READ_COILS;
        ReadCmd.ReadAdr:=19;
        ReadCmd.ReadSize:=1;
        ModbusStage=1;
        DevicePort.DeviceType:=_eDEVICE_TYPE#_DeviceNXUnit;
        DevicePort.NxUnit:=N1_Node_location_information;
        DevicePort.PortNo:=2;
    END_IF;
    // Command sending/receiving
    NX_ModbusRtuRead_instance (Execute:=ModbusCmdRequestTrigger,
                               DevicePort:=DevicePort,
                               SlaveAdr:=SlaveAdr,
                               ReadCmd:=ReadCmd,
                               ReadDat:=ReadDat,
                               Done=>Done,
                               Busy=>Busy,
                               Error=>Error,
                               ReadSize=>ReadSize);

    IF (ModbusStage=1) THEN
        // Sending/receiving finished successfully.
        IF (Error=FALSE) THEN
            ModbusStage:=2;
        // Error occurred.
        ELSE
            ModbusStage:=0;
            ModbusCmdRequestTrigger:=FALSE;
        END_IF;
    ELSIF (ModbusStage=2) THEN
        // Reception completed.
        IF (Error=FALSE) AND (Done=TRUE) THEN
            ModbusStage:=0;
            ModbusCmdRequestTrigger:=FALSE;
        // Reception processing in progress
        ELSIF (Busy=TRUE) THEN

            // Reception failed.
        ELSE

            ModbusStage:=0;
            ModbusCmdRequestTrigger:=FALSE;
        END_IF;
    END_IF;
END_IF;

```

NX_ModbusRtuWrite

The NX_ModbusRtuWrite instruction sends write commands from a serial port on an NX-series Communications Interface Unit or Option Board to Modbus-RTU slaves using Modbus-RTU protocol.

Instruction	Name	FB/ FUN	Graphic expression	ST expression
NX_ModbusRtuWrite	Send Modbus RTU Write Command	FB		NX_ModbusRtuWrite_instance(Execute, DevicePort, SlaveAdr, WriteCmd, WriteDat, Option, Abort, Done, Busy, CommandAborted, Error, ErrorID, ErrorIDEx);



Version Information

A CPU Unit with unit version 1.11 or later and Sysmac Studio version 1.15 or higher are required to use this instruction.

Variables

Name	Meaning	I/O	Description	Valid range	Unit	Default
DevicePort	Device port	Input	Object that represents a device port	---	---	---
SlaveAdr	Slave address		Address of Modbus-RTU slave*1	0 to 247	---	1
WriteCmd	Write command		Write command	---	---	*2
WriteDat[] (array)	Write data		Write data	Depends on data type.	---	*2
Option	Option		Option	---	---	---
Abort	Interruption	Output	Interruption of instruction execution	Depends on data type.	---	FALSE
Command-Aborted	Interruption completion		Interruption completion	Depends on data type.	---	---

*1 If 0 is set, you can broadcast commands to Modbus-RTU slaves.

*2 If you omit an input parameter, the default value is not applied. A building error will occur.

	Boolean	Bit strings				Integers							Real numbers	Times, durations, dates, and text strings						
	BOOL	BYTE	WORD	DWORD	LWORD	USINT	UINT	UDINT	ULINT	SINT	INT	DINT	LINT	REAL	LREAL	TIME	DATE	TOD	DT	STRING
DevicePort	Refer to <i>Function</i> for details on the structure <code>_sDEVICE_PORT</code> .																			
SlaveAdr						OK														
WriteCmd	Refer to <i>Function</i> for details on the structure <code>_sSERIAL_MODBUSRTU_WRITE</code> .																			
WriteDat[] (array)	OK		OK																	
	An array can also be specified.																			
Option	Refer to <i>Function</i> for details on the structure <code>_sSERIAL_MODBUSRTU_OPTION</code> .																			
Abort	OK																			
Command-Aborted	OK																			

Function

The `NX_ModbusRtuWrite` instruction sends write commands from a serial port on an NX-series Communications Interface Unit or Option Board to Modbus-RTU slaves using Modbus-RTU protocol.

This instruction ends normally when a normal response to the sent command is received.

When a command is broadcasted, this instruction ends normally without waiting for responses from slaves.

The data type of the `DevicePort` input variable is structure `_sDEVICE_PORT`. The specifications are as follows:

Name	Meaning	Description	Data type	Valid range	Unit	Default
DevicePort	Device port	Object that represents a device port	<code>_sDEVICE_PORT</code>	---	---	---
DeviceType	Device type	Type of the device to specify	<code>_eDEVICE_TYPE</code>	<code>_DeviceNXUnit</code> <code>_DeviceEcatSlave</code> <code>_DeviceOptionBoard</code>	---	---
NxUnit	Specified Unit	NX Unit to control	<code>_sNXUNIT_ID</code>	---	---	---
EcatSlave	Specified slave	EtherCAT slave to control	<code>_sECAT_ID</code>	---	---	---
OptBoard	Specified Option Board	Option Board to control	<code>_sOPTBOARD_ID</code>	---	---	---
Reserved	Reserved	Reserved	Reserved	---	---	---
PortNo	Port number	Port number 1: Port 1 2: Port 2	USINT	Depends on data type.	---	---

Use `DeviceType` to specify the device type. Set this to `_DeviceNXUnit` for an NX Unit and `_DeviceOptionBoard` for an Option Board. The variable used to specify the device is determined by the specified device type.

To specify an NX Unit, use `NxUnit` to specify the device.

In this case, `EcatSlave` and `OptBoard` are not used.

To *NxUnit*, pass the device variable that is assigned to the node location information on the I/O Map for the device to specify.

To specify an Option Board, use *OptBoard* to specify the device.

In this case, *NxUnit* and *EcatSlave* are not used.

To *OptBoard*, pass the device variable that is assigned to the node location information on the I/O Map for the device to specify.

If you use this instruction, be sure to assign a device variable to the node location information. Do not assign device variables to any I/O ports following the node location information that are indicated by “W” under the R/W column.

The figure below is an example of using this instruction for port 1 on an NX-CIF210.

Position	Port	Description	R/W	Data Type	Variable
Unit1	NX-CIF210	Node location information	R	_sNXUNIT_ID	N1_Node_location_information
⋮					
		Ch1 Output SID	W	USINT	
		Ch1 Input SID Response	W	USINT	
		▶ Ch1 Output Data Type	W	WORD	
		Ch1 Output Sub Info	W	WORD	
		Ch1 Output Data Length	W	UINT	
		▶ Ch1 Output Data 01	W	ARRAY[0..3] OF BYTE	
		▶ Ch1 Output Data 02	W	ARRAY[0..3] OF BYTE	
		▶ Ch1 Output Data 03	W	ARRAY[0..3] OF BYTE	
		▶ Ch1 Output Data 04	W	ARRAY[0..3] OF BYTE	
		▶ Ch1 Output Data 05	W	ARRAY[0..3] OF BYTE	

Refer to the *Sysmac Studio Version 1 Operation Manual* (Cat. No. W504-E1-07 or later) for details on assigning a device variable to the node location information.

Use *PortNo* to specify the port number.

1: Port 1

2: Port 2

For an NX Unit, set this to Port 1 or Port 2.

For an Option Board, set this to Port 1.

The data type of *DeviceType* is enumerated type `_eDEVICE_TYPE`.

The meanings of the enumerators of enumerated type `_eDEVICE_TYPE` are as follows:

Enumerator	Meaning
<code>_DeviceNXUnit</code>	NX Unit is specified.
<code>_DeviceEcatSlave</code>	EtherCAT slave is specified.
<code>_DeviceOptionBoard</code>	Option Board is specified.

In this instruction, you can specify `_DeviceNXUnit` or `_DeviceOptionBoard`.

Use the *SlaveAdr* input variable to specify the address of a Modbus-RTU slave.

To broadcast commands to Modbus-RTU slaves, set the *SlaveAdr* input variable to 0.

Use the *WriteCmd* input variable to specify the write command.

CRC is attached by the instruction.

The data type of *WriteCmd* input variable is structure `_sSERIAL_MODBUSRTU_WRITE`. The specifications are as follows:

Name	Meaning	Description	Data type	Valid range	Unit	Default
WriteCmd	Write command	Write command	<code>_sSERIAL_MODBUSRTU_WRITE</code>	---	---	---
Fun	Function code	Function code	<code>_eMDB_FUN</code>	<code>_MDB_WRITE_SINGLE_COIL</code> <code>_MDB_WRITE_SINGLE_REGISTER</code> <code>_MDB_WRITE_MULTIPLE_COILS</code> <code>_MDB_WRITE_MULTIPLE_REGISTERS</code>	---	<code>_eMDB_WRITE_SINGLE_COIL</code>
WriteAdr	Write address	Write start address	UINT	Depends on data type.	---	0
WriteSize	Write size	Write size	UINT	Depends on function code.	---	<code>_MDB_WRITE_SINGLE_COIL</code>

The data type of *Fun* is enumerated type `_eMDB_FUN`.

The meanings of the enumerators of enumerated type `_eMDB_FUN` are as follows:

Enumerator	Meaning
<code>_MDB_WRITE_SINGLE_COIL</code>	Write an output (bit)
<code>_MDB_WRITE_SINGLE_REGISTER</code>	Write a holding register (word)
<code>_MDB_WRITE_MULTIPLE_COILS</code>	Write multiple outputs (bit)
<code>_MDB_WRITE_MULTIPLE_REGISTERS</code>	Write multiple holding registers (word)

The valid range that you can specify with *WriteSize* varies depending on the function code.

Each value is determined by the size of data that is written and the maximum command length.

The specifications are as follows:

Function code	WriteSize
<code>_MDB_WRITE_SINGLE_COIL</code>	1 (bit)
<code>_MDB_WRITE_SINGLE_REGISTER</code>	1 (word)
<code>_MDB_WRITE_MULTIPLE_COILS</code>	1 to 1,968 (bit)
<code>_MDB_WRITE_MULTIPLE_REGISTERS</code>	1 to 123 (word)

Use the *WriteDat* input variable to specify the data to write.

The data type that you can use for *WriteDat* differs depending on the function code.

The specifications are as follows:

Function code	Data type
_MDB_WRITE_SINGLE_COIL	BOOL BOOL[]
_MDB_WRITE_SINGLE_REGISTER	WORD WORD[]
_MDB_WRITE_MULTIPLE_COILS	BOOL BOOL[]
_MDB_WRITE_MULTIPLE_REGISTERS	WORD WORD[]

To set options, use the *Option* input variable. The specifications are as follows:

The data type of the *Option* input variable is structure `_sSERIAL_MODBUS_OPTION`. The specifications are as follows:

Name	Meaning	Description	Data type	Valid range	Unit	Default
Option	Option	Option	<code>_sSERIAL_MODBUSRTU_OPTION</code>	---	---	---
SendDelay	Send delay time	Send delay time	UINT	Depends on data type.	0.01 s	0
TimeOut	Timeout time	2.0 s when the timeout time is set to 0	UINT	Depends on data type.	0.1 s	20
NoResponse	No response	Not used in this instruction.	BOOL	Depends on data type.	---	FALSE
Retry	Retry count	Retry count	USINT	0 to 15	---	0

An error occurs if this instruction is executed for Units other than NX-series Communications Interface Units and Option Boards.

Interruption of Instruction Execution

If *Abort* is changed to TRUE during instruction execution, the execution is interrupted.

When the instruction execution is interrupted, *CommandAborted* changes to TRUE.

If the change of *Abort* is too late to interrupt the execution, *Done* changes to TRUE and the instruction ends normally.

If both *Abort* and *Execute* are changed to TRUE, *CommandAborted* changes to TRUE.

This interruption operation only finishes the *Busy* processing for the instruction, and it does not clear the send or receive buffer. To clear the buffer, use the `NX_SerialBufClear` instruction.

Timing Charts

The following figures show the timing charts.

● Normal end (when *SendDelay* is 0 (0 s))

The operation is as follows when *SendDelay* is 0 (0 s).

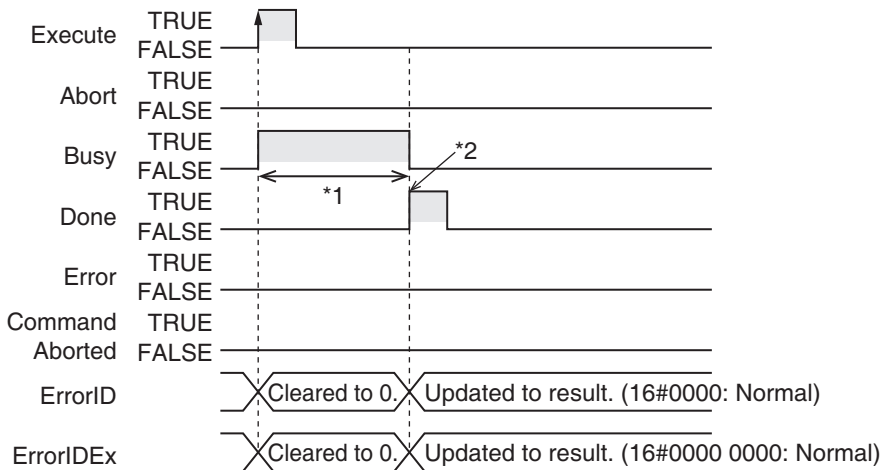

● Normal end (when *SendDelay* is 100 (1 s))

The operation is as follows when *SendDelay* is 100 (1 s).

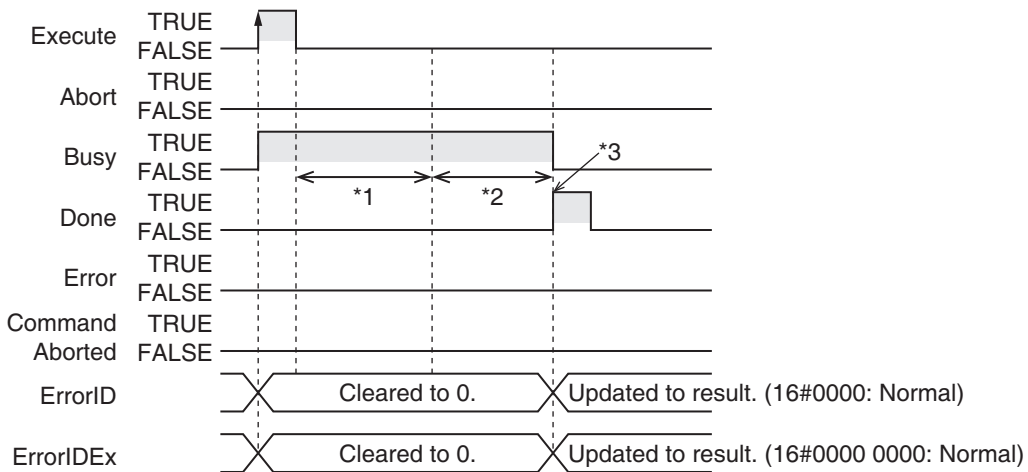

● **Interruption executed (when *Busy* is TRUE)**

The operation is as follows if *Abort* is changed to TRUE while *Busy* is TRUE.

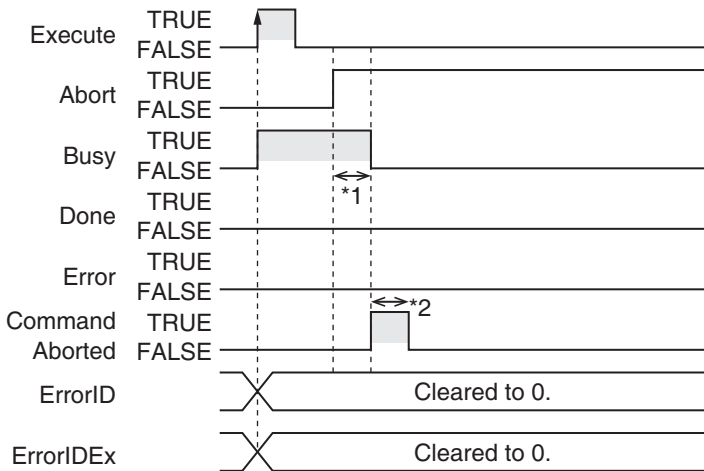

*1 Interruption processing

*2 Changes to FALSE after one task period.

● **Interruption executed (when *Execute* is TRUE)**

The operation is as follows if both *Abort* and *Execute* are changed to TRUE.

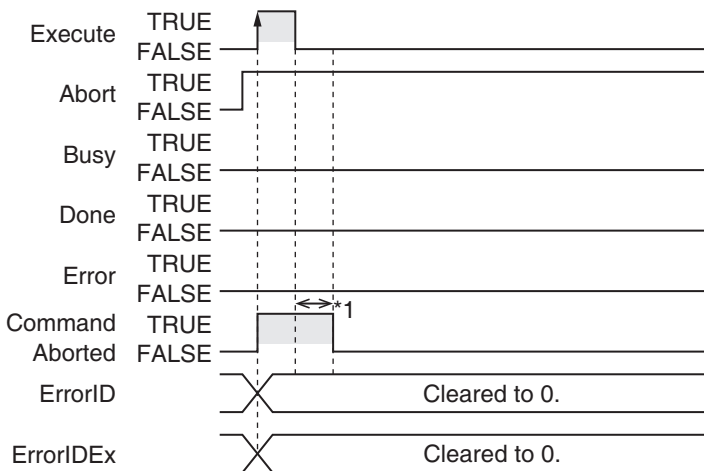

*1 Changes to FALSE after one task period.

Related System-defined Variables

Name	Meaning	Data type	Description
_PLC_OptBoardSta	Option Board Status	ARRAY[1..2] of _sOPTBOARD_STA	<ul style="list-style-type: none"> This stores the status of the Option Board.
_NXB_UnitIOActiveTbl	NX Unit I/O Data Active Status	ARRAY[0..8] OF BOOL	<ul style="list-style-type: none"> This status tells the NX Units whether I/O data communications can be processed. The subscript of the array corresponds to the NX Unit numbers. A subscript of 0 means the NX bus master.

Additional Information

Refer to the *MODBUS Application Protocol Specification* for the specifications of the MODBUS communications protocol.

You can obtain *MODBUS Application Protocol Specification* from Modbus Organization, Inc.

<http://www.modbus.org/>

Precautions for Correct Use

- Execution of this instruction is continued until processing is completed even if the value of *Execute* changes to FALSE or the execution time exceeds the task period. The value of *Done* changes to TRUE when processing is completed. Use this to confirm normal completion of processing. If *Abort* is changed to TRUE during instruction execution, *CommandAborted* or *Done* changes to TRUE.
- A compiling error will occur if you use this instruction in an event task. Do not use this instruction in event tasks.
- A CIF Unit Initialized error may occur when the NX-series Communications Interface Unit is restarted. Send or receive the data again, if necessary.
- If you use this instruction, do not assign device variables to any I/O ports that are indicated by "W" under the R/W column on the I/O Map Tab Page in the Sysmac Studio for the applicable NX-series Communications Interface Unit.
- Data may still remain in the buffer of the target device port in the following cases. To clear the buffer, execute the NX_SerialBufClear instruction before executing the following instruction: NX_ModbusRtuCmd instruction, NX_ModbusRtuRead instruction, or NX_ModbusRtuWrite instruction.
 - After the operation starts or when you change the operating mode to RUN mode.
 - The retry was set (i.e., *Option.Retry* is not 0) in the previous instruction execution.
 - The previous instruction execution is interrupted (i.e., the *CommandAborted* output variable is TRUE).
 - An error occurred (i.e., *Error* is TRUE) in the previous instruction execution.
- An error will occur in the following cases. *Error* will change to TRUE.
 - A value that is out of range was set for *SlaveAdr*, *WriteCmd.Fun*, *WriteCmd.WriteSize*, *Option.Retry*, *DevicePort.DevicePortType*, or *DevicePort.PortNo*.
 - The variable specified with *WriteDat* is smaller than the size specified with *WriteCmd.WriteSize*.
 - The Unit or port specified with *DevicePort* does not exist.
 - The data type of *DevicePort* or *WriteDat* is invalid.
 - If more than 32 instructions from the NX_SerialSend instruction, NX_SerialRcv instruction, NX_ModbusRtuCmd instruction, NX_ModbusRtuRead instruction, NX_ModbusRtuWrite instruction, NX_SerialSigCtl instruction, NX_SerialSigRead instruction, NX_SerialStatusRead instruction, NX_SerialBufClear instruction, NX_SerialStartMon instruction and NX_SerialStopMon instruction are executed at the same time.
 - This instruction is executed with a device port variable that is the same as the one specified for the instruction which is still being executed. In this case, the instruction which is still being executed is one of the followings.
The NX_SerialSend instruction, NX_SerialRcv instruction, NX_ModbusRtuCmd instruction, NX_ModbusRtuRead instruction, and NX_ModbusRtuWrite instruction.
 - A parity error occurred in the data received.
 - A framing error occurred in the data received.
 - An overrun error occurred in the data received.
 - CRC mismatch occurred for the received data.
 - Timeout time elapsed.
 - This instruction is executed for Units other than NX-series Communications Interface Units and Option Boards.

- An Exception Response was received from a Modbus-RTU slave. You can check Exception Codes with the *ErrorIDEx* output variable.
- There was an invalid function code, receive size, etc. in the response data from a Modbus-RTU slave.
- The serial communications mode of the specified Option Board is not *Modbus-RTU master*.
- In this instruction, the expansion error code *ErrorIDEx* is displayed when an error is detected in a Modbus-RTU slave. An expansion error code is output to *ErrorIDEx* when the value of error code *ErrorID* is WORD#16#0C10. The display format is ErrorIDEx=000000XX. For the value XX, refer to the Exception Code specifications of the MODBUS communications protocol.
Refer to the *MODBUS Application Protocol Specification* for the Exception Code specifications of the MODBUS communications protocol.
You can obtain *MODBUS Application Protocol Specification* from Modbus Organization, Inc.
<http://www.modbus.org/>

Sample Programming

In this sample, an NX-series Communications Interface Unit (NX-CIF210) is connected to an EtherCAT Coupler Unit (NX-ECC203).

The unit number of the NX-CIF210 is set to 1.

For the Unit operation settings of the NX-CIF210, set **Ch2 Number of Characters to Determine the End** to 35. The number of characters is regarded as 3.5 during operation because the unit for setting the Number of Characters to Determine the End is 0.1 character.

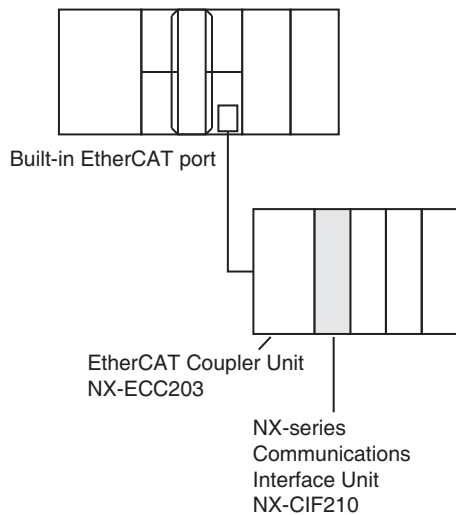

A Modbus-RTU command is sent from serial port 2 of the NX-CIF210.

When *ModbusCmdRequestTrigger* turns ON, an output starting from address 149 in slave address 1 is turned ON.

Write commands are sent/received to write a variable.

Internal Variables	Variable	Data type	Initial value	Comment
	NX_ModbusRtuWrite_instance	NX_ModbusRtuWrite		
	Done	BOOL	BOOL#FALSE	
	Busy	BOOL	BOOL#FALSE	
	ModbusStage	INT	INT#0	MODBUS communications status
	Error	BOOL		
	ErrorID	WORD		
	ModbusCmdRequestTrigger	BOOL	FALSE	Execution condition
	SlaveAdr	UINT	UINT#0	Slave address
	DevicePort	_sDEVICE_PORT		Port settings
	WriteCmd	_sSERIAL_MODBUS-RTU_WRITE		
	WriteDat	BOOL	[6(16#0)]	

```

IF ( (ModbusCmdRequestTrigger=TRUE)
    AND (ModbusStage=INT#0) ) THEN

    WriteCmd.FUN:=WRITE_SINGLE_COIL;
    WriteCmd.WriteAdr:=149;
    WriteCmd.WriteSize:=1;

    ModbusCmdRequestTrigger:= FALSE;
    ModbusStage:=1;
    DevicePort.DeviceType:=_eDEVICE_TYPE#_DeviceNXUnit;
    DevicePort.NxUnit:=N1_Node_location_information;
    DevicePort.PortNo:=2;
END_IF;

// Command sending/receiving
NX_ModbusRtuWrite_instance (Execute:=ModbusCmdRequestTrigger,
                            DevicePort:=DevicePort,
                            SlaveAdr:=SlaveAdr,
                            WriteCmd:=WriteCmd,
                            WriteDat:=WriteDat,
                            Error=>Error,
                            ErrorID=>ErrorID);

IF (ModbusStage=1) THEN
    // Sending/receiving finished successfully.
    IF (Error=FALSE) THEN
        ModbusStage:=2;
    // Error occurred.
    ELSE
        ModbusStage:=0;
    END_IF;
ELSIF (ModbusStage=2) THEN
    // Reception completed.
    IF (Error=FALSE) AND (Done=TRUE) THEN
        ModbusStage:=0;
    // Reception processing in progress
    ELSIF (Busy=TRUE) THEN

        // Reception failed.
        ELSE

            ModbusStage:=0;
        END_IF;
    END_IF;
END_IF;

```

NX_SerialSigCtl

The NX_SerialSigCtl instruction turns ON or OFF the ER or RS signal of a serial port on an NX-series Communications Interface Unit or Option Board.

Instruction	Name	FB/ FUN	Graphic expression	ST expression
NX_SerialSigCtl	Serial Control Signal ON/OFF Switching	FB		NX_SerialSigCtl_instance(Execute, DevicePort, Kind, Sig, TimeOut, Done, Busy, Error, ErrorID);

Version Information

A CPU Unit with unit version 1.11 or later and Sysmac Studio version 1.15 or higher are required to use this instruction.

Variables

Name	Meaning	I/O	Description	Valid range	Unit	Default
DevicePort	Device port	Input	Object that represents a device port	---	---	---
Kind	Signal command		Signal command	_RS_SIG _ER_SIG*1	---	*2
Sig	ON/OFF command		ON/OFF command	Depends on data type.	---	*2
TimeOut	Timeout time		2.0 s when the timeout time is set to 0	Depends on data type.	0.1 s	0

*1 You cannot use _CS_SIG or _DR_SIG. If either of them is specified, an error will occur when the instruction is executed.

*2 If you omit an input parameter, the default value is not applied. A building error will occur.

	Boolean	Bit strings				Integers							Real numbers	Times, durations, dates, and text strings						
	BOOL	BYTE	WORD	DWORD	LWORD	USINT	UINT	UDINT	ULINT	SINT	INT	DINT	LINT	REAL	LREAL	TIME	DATE	TOD	DT	STRING
DevicePort																				
Kind																				
Sig	OK																			
TimeOut							OK													

Function

The `NX_SerialSigCtl` instruction turns ON or OFF the ER or RS signal of a serial port on an NX-series Communications Interface Unit or Option Board.

The data type of the *DevicePort* input variable is structure `_sDEVICE_PORT`. The specifications are as follows:

Name	Meaning	Description	Data type	Valid range	Unit	Default
DevicePort	Device port	Object that represents a device port	<code>_sDEVICE_PORT</code>	---	---	---
DeviceType	Device type	Type of the device to specify	<code>_eDEVICE_TYPE</code>	<code>_DeviceNXUnit</code> <code>_DeviceEcatSlave</code> <code>_DeviceOptionBoard</code>	---	---
NxUnit	Specified Unit	NX Unit to control	<code>_sNXUNIT_ID</code>	---	---	---
EcatSlave	Specified slave	EtherCAT slave to control	<code>_sECAT_ID</code>	---	---	---
OptBoard	Specified Option Board	Option Board to control	<code>_sOPTBOARD_ID</code>	---	---	---
Reserved	Reserved	Reserved	Reserved	---	---	---
PortNo	Port number	Port number 1: Port 1 2: Port 2	USINT	Depends on data type.	---	---

Use *DeviceType* to specify the device type. Set this to `_DeviceNXUnit` for an NX Unit and `_DeviceOptionBoard` for an Option Board. The variable used to specify the device is determined by the specified device type.

To specify an NX Unit, use *NxUnit* to specify the device.

In this case, *EcatSlave* and *OptBoard* are not used.

To *NxUnit*, pass the device variable that is assigned to the node location information on the I/O Map for the device to specify.

To specify an Option Board, use *OptBoard* to specify the device.

In this case, *NxUnit* and *EcatSlave* are not used.

To *OptBoard*, pass the device variable that is assigned to the node location information on the I/O Map for the device to specify.

If you use this instruction, be sure to assign a device variable to the node location information. Do not assign device variables to any I/O ports following the node location information that are indicated by “W” under the R/W column.

The figure below is an example of using this instruction for port 1 on an NX-CIF210.

Position	Port	Description	R/W	Data Type	Variable
Unit1	NX-CIF210	Node location information	R	_sNXUNIT_ID	N1_Node_location_information
⋮					
		Ch1 Output SID	W	USINT	
		Ch1 Input SID Response	W	USINT	
		▶ Ch1 Output Data Type	W	WORD	
		Ch1 Output Sub Info	W	WORD	
		Ch1 Output Data Length	W	UINT	
		▶ Ch1 Output Data 01	W	ARRAY[0..3] OF BYTE	
		Ch1 Output Data 02	W	ARRAY[0..3] OF BYTE	
		▶ Ch1 Output Data 03	W	ARRAY[0..3] OF BYTE	
		▶ Ch1 Output Data 04	W	ARRAY[0..3] OF BYTE	
		▶ Ch1 Output Data 05	W	ARRAY[0..3] OF BYTE	

Refer to the *Sysmac Studio Version 1 Operation Manual* (Cat. No. W504-E1-07 or later) for details on assigning a device variable to the node location information.

Use *PortNo* to specify the port number.

- 1: Port 1
- 2: Port 2

For an NX Unit, set this to Port 1 or Port 2.

For an Option Board, set this to Port 1.

The data type of *DeviceType* is enumerated type `_eDEVICE_TYPE`.

The meanings of the enumerators of enumerated type `_eDEVICE_TYPE` are as follows:

Enumerator	Meaning
<code>_DeviceNXUnit</code>	NX Unit is specified.
<code>_DeviceEcatSlave</code>	EtherCAT slave is specified.
<code>_DeviceOptionBoard</code>	Option Board is specified.

In this instruction, you can specify `_DeviceNXUnit` or `_DeviceOptionBoard`.

Use the *Kind* input variable to select the ER or RS signal.

When the *Sig* input variable is TRUE, the ER or RS signal turns ON.

When the *Sig* input variable is FALSE, the ER or RS signal turns OFF.

The data type of *Kind* is enumerated type `_eSERIAL_SIG`.

The meanings of the enumerators of enumerated type `_eSERIAL_SIG` are as follows:

Enumerator	Meaning
<code>_RS_SIG</code>	RS signal
<code>_ER_SIG</code>	ER signal
<code>_CS_SIG</code>	CS signal
<code>_DR_SIG</code>	DR signal

An error occurs if this instruction is executed for Units other than NX-series Communications Interface Units and Option Boards.

Timing Charts

The following figures show the timing charts.

● Normal end

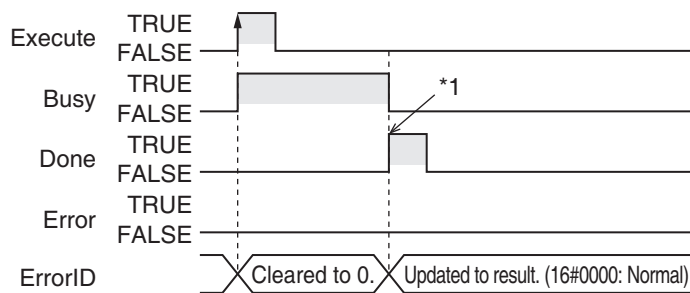

*1 Signal ON/OFF control is completed.

● Error end

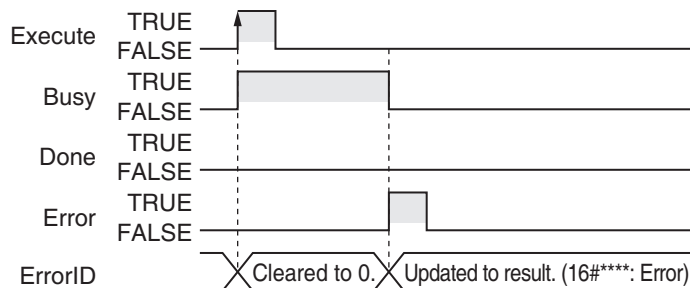

Related System-defined Variables

Name	Meaning	Data type	Description
<code>_PLC_OptBoardSta</code>	Option Board Status	ARRAY[1..2] of <code>_sOPTBOARD_STA</code>	<ul style="list-style-type: none"> This stores the status of the Option Board.
<code>_NXB_UnitIOActiveTbl</code>	NX Unit I/O Data Active Status	ARRAY[0..8] OF <code>BOOL</code>	<ul style="list-style-type: none"> This status tells the NX Units whether I/O data communications can be processed. The subscript of the array corresponds to the NX Unit numbers. A subscript of 0 means the NX bus master.

Precautions for Correct Use

- Execution of this instruction is continued until processing is completed even if the value of *Execute* changes to FALSE or the execution time exceeds the task period. The value of *Done* changes to TRUE when processing is completed. Use this to confirm normal completion of processing.
- A compiling error will occur if you use this instruction in an event task. Do not use this instruction in event tasks.
- This instruction does not check the communications protocol and wiring conditions. Check the wiring conditions and communications protocol before you use this instruction.
- A CIF Unit Initialized error may occur when the NX-series Communications Interface Unit is restarted. Send or receive the data again, if necessary.
- If you use this instruction, do not assign device variables to any I/O ports that are indicated by "W" under the R/W column on the I/O Map Tab Page in the Sysmac Studio for the applicable NX-series Communications Interface Unit.
- An error will occur in the following cases. *Error* will change to TRUE.
 - A value that is out of range was set for *Kind*, *DevicePort.DevicePortType*, or *DevicePort.PortNo*.
 - The Unit, Option Board, or port specified with *DevicePort* does not exist.
 - If an RS-422A/485 serial port is specified for *DevicePort*.
 - When **RS/CS flow control** is selected for the flow control setting of the NX-series Communications Interface Unit and this instruction sends "RS Signal ON" or "RS Signal OFF".
 - If more than 32 instructions from the NX_SerialSend instruction, NX_SerialRcv instruction, NX_ModbusRtuCmd instruction, NX_ModbusRtuRead instruction, NX_ModbusRtuWrite instruction, NX_SerialSigCtl instruction, NX_SerialSigRead instruction, NX_SerialStatusRead instruction, NX_SerialBufClear instruction, NX_SerialStartMon instruction and NX_SerialStopMon instruction are executed at the same time.
 - This instruction is executed with a device port variable that is the same as the one specified for the instruction which is still being executed. In this case, the instruction which is still being executed is one of the followings.
The NX_SerialSigRead instruction, NX_SerialStatusRead instruction, NX_SerialSigCtl instruction, NX_SerialBufClear instruction, NX_SerialStartMon instruction, and NX_SerialStopMon instruction.
 - Timeout time elapsed during serial communications.
 - This instruction is executed for Units other than NX-series Communications Interface Units and Option Boards.
 - The serial communications mode of the specified Option Board is not *No-protocol* or *Modbus-RTU master*.

Sample Programming

In this sample, an NX-series Communications Interface Unit (NX-CIF210) is connected to an EtherCAT Coupler Unit (NX-ECC203).

The unit number of the NX-CIF210 is set to 1.

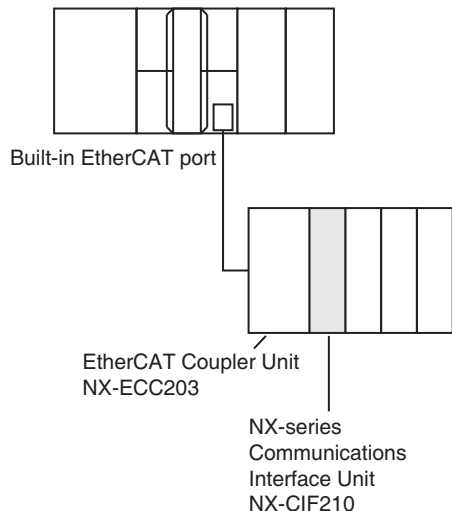

The ER signal is turned ON if the SetER signal is turned ON for a no-protocol remote node that is connected to serial port 2 of the NX-CIF210. The ER signal is turned OFF if the ResetER signal is turned ON for the same remote node.

Definitions of Global Variables

Global Variables

Name	Data type	AT	Comment
E001_NX_Unit_I_O_Data_Active_Status_63	ARRAY[0..63] OF BOOL	ECAT://node#1/NX Unit I/O Data Active Status 125	Usage of I/O data for 63 NX Units.
N1_Node_location_information	_sNXUNIT_ID	---	Device variable to specify NX-CIF210*1

*1 On the Sysmac Studio, right-click an NX-series slave terminal unit, select **Display Node Location Port**, and set the device variable. Refer to the *Sysmac Studio Version 1 Operation Manual* (Cat. No. W504-E1-07 or later) for details.

LD

Internal Variables	Variable	Data type	Initial value	Comment
	OperationEnd	BOOL	FALSE	Processing completed
	SetER	BOOL	FALSE	ER signal ON execution condition
	ResetER	BOOL	FALSE	ER signal OFF execution condition
	Operating	BOOL	FALSE	Processing
	DevicePort	_sDEVICE_PORT		Port settings
	RS_instance	RS	---	<i>Operating</i> retained
	CfgValue	RS	---	Value determined by <i>SetER</i> or <i>ResetER</i>
	NX_SerialSigCtl_instance	NX_SerialSigCtl	---	

External Variables	Variable	Data type	Comment
	E001_NX_Unit_I_O_Data_Active_Status_63	ARRAY[0..63] OF BOOL	<ul style="list-style-type: none"> Usage of I/O data for 63 NX Units. If the relevant Unit number is 1, E001_NX_Unit_I_O_Data_Active_Status_63[1] is used.
	N1_Node_location_information	_sNXUNIT_ID	Device variable to specify NX-CIF210

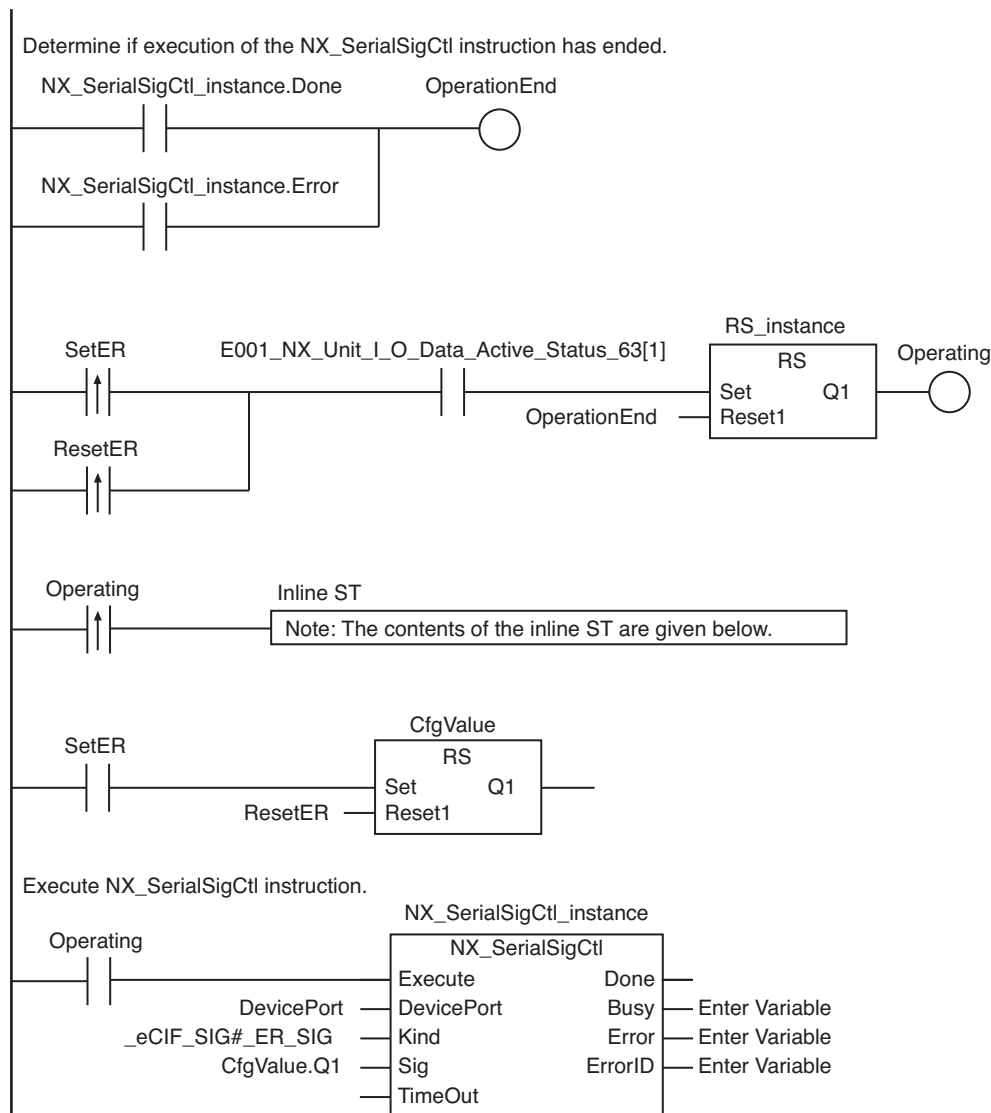

● Contents of Inline ST

```
DevicePort.DeviceType:=_eDEVICE_TYPE#_DeviceNXUnit;
DevicePort.NxUnit:=N1_Node_location_information;
DevicePort.PortNo:=2;
```

ST

Internal Variables	Variable	Data type	Initial value	Comment
	OperatingStart	BOOL	FALSE	Processing started
	SetER	BOOL	FALSE	ER signal ON execution condition
	ResetER	BOOL	FALSE	ER signal OFF execution condition
	DevicePort	_sDEVICE_PORT		Port settings
	CfgValue	RS	---	Value determined by SetER or ResetER
	NX_SerialSigCtl_instance	NX_SerialSigCtl	---	

External Variables	Name	Data type	Comment
	E001_NX_Unit_I_O_Data_Active_Status_63	ARRAY[0..63] OF BOOL	<ul style="list-style-type: none"> Usage of I/O data for 63 NX Units. If the relevant Unit number is 1, E001_NX_Unit_I_O_Data_Active_Status_63[1] is used.
	N1_Node_location_information	_sNXUNIT_ID	Device variable to specify NX-CIF210

```

// Detection of SetER or ResetER
IF (NX_SerialSigCtl_instance.Done OR NX_SerialSigCtl_instance.Error) THEN
    OperatingStart:=FALSE;
ELSE_IF
    OperatingStart:=(SetER OR ResetER)
                        AND E001_NX_Unit_I_O_Data_Active_Statu-
tus_63 [1]
                        AND NOT(P_FirstRun);
    DevicePort.DeviceType:=_eDEVICE_TYPE#_DeviceNXUnit;
    DevicePort.NxUnit:=N1_Node_location_information;
    DevicePort.PortNo:=2;
END_IF;

// ER signal value is determined.
CfgValue(Set:=SetER, Reset1:=ResetER);

// NX_SerialSigCtl instruction is executed.
NX_SerialSigCtl_instance(Execute:=OperatingStart,
                        DevicePort:=DevicePort,
                        Kind:=_eSERIAL_SIG#_SIG_ER,
                        Sig:=CfgValue.Q1);

```

NX_SerialSigRead

The NX_SerialSigRead instruction reads the CS or DR signal of a serial port on an Option Board.

Instruction	Name	FB/ FUN	Graphic expression	ST expression
NX_SerialSigRead	Read Serial Control Signal	FB		NX_SerialSigRead_instance(Execute, DevicePort, Kind, TimeOut, Done, Busy, Error, ErrorID, Sig);



Precautions for Correct Use

You can use this instruction for an Option Board for the NX1P2 CPU Unit only.

Variables

Name	Meaning	I/O	Description	Valid range	Unit	Default
DevicePort	Device port	Input	Object that represents a device port	---	---	---
Kind	Signal command		Signal command	_CS_SIG _DR_SIG *1	---	*2
TimeOut	Timeout time		2.0 s when the timeout time is set to 0	Depends on data type.	0.1 s	0
Sig	Signal	Output	Outputs the signal that was read.	Depends on data type.	---	---

*1 You cannot use _RS_SIG or _ER_SIG. If either of them is specified, an error will occur when the instruction is executed.

*2 If you omit an input parameter, the default value is not applied. A building error will occur.

	Boolean	Bit strings				Integers								Real numbers	Times, durations, dates, and text strings					
	BOOL	BYTE	WORD	DWORD	LWORD	USINT	UINT	UDINT	ULINT	SINT	INT	DINT	LINT	REAL	LREAL	TIME	DATE	TOD	DT	STRING
DevicePort																				
Kind																				
TimeOut							OK													
Sig	OK																			

Function

The NX_SerialSigRead instruction reads the CS or DR signal of a serial port on an Option Board. If a signal that was read is ON, the *Sig* output variable is TRUE. If the signal is OFF, Sig is FALSE. The data type of the *DevicePort* input variable is structure `_sDEVICE_PORT`. The specifications are as follows:

Name	Meaning	Description	Data type	Valid range	Unit	Default
DevicePort	Device port	Object that represents a device port	<code>_sDEVICE_PORT</code>	---	---	---
DeviceType	Device type	Type of the device to specify	<code>_eDEVICE_TYPE</code>	<code>_DeviceNXUnit</code> <code>_DeviceEcatSlave</code> <code>_DeviceOptionBoard</code>	---	---
NxUnit	Specified Unit	NX Unit to control	<code>_sNXUNIT_ID</code>	---	---	---
EcatSlave	Specified slave	EtherCAT slave to control	<code>_sECAT_ID</code>	---	---	---
OptBoard	Specified Option Board	Option Board to control	<code>_sOPTBOARD_ID</code>	---	---	---
Reserved	Reserved	Reserved	Reserved	---	---	---
PortNo	Port number	Port number 1: Port 1 2: Port 2	USINT	Depends on data type.	---	---

Use *DeviceType* to specify the device type. For an Option Board, set this to `_DeviceOptionBoard`. The variable used to specify the device is determined by the specified device type.

To specify an Option Board, use *OptBoard* to specify the device.

In this case, *NxUnit* and *EcatSlave* are not used.

To *OptBoard*, pass the device variable that is assigned to the node location information on the I/O Map for the device to specify.

If you use this instruction, be sure to assign a device variable to the node location information. Do not assign device variables to any I/O ports following the node location information that are indicated by “W” under the R/W column.

The figure below is an example of using this instruction for port 1 on an NX-CIF210.

Assign a variable.

Position Unit1	Port	Description	R/W	Data Type	Variable
	▼ NX-CIF210	Node location information	R	_sNXUNIT_ID	N1_Node_location_information
⋮					
		Ch1 Output SID	W	_USINT	
		Ch1 Input SID Response	W	_USINT	
		▶ Ch1 Output Data Type	W	_WORD	
		Ch1 Output Sub Info	W	_WORD	
		Ch1 Output Data Length	W	_UINT	
		▶ Ch1 Output Data 01	W	ARRAY[0..3] OF BYTE	
		▶ Ch1 Output Data 02	W	ARRAY[0..3] OF BYTE	
		▶ Ch1 Output Data 03	W	ARRAY[0..3] OF BYTE	
		▶ Ch1 Output Data 04	W	ARRAY[0..3] OF BYTE	
		▶ Ch1 Output Data 05	W	ARRAY[0..3] OF BYTE	

Do not assign variables.

Refer to the *Sysmac Studio Version 1 Operation Manual* (Cat. No. W504-E1-07 or later) for details on assigning a device variable to the node location information.

Use *PortNo* to specify the port number.

1: Port 1

2: Port 2

For an Option Board, set this to Port 1.

The data type of *DeviceType* is enumerated type `_eDEVICE_TYPE`.

The meanings of the enumerators of enumerated type `_eDEVICE_TYPE` are as follows:

Enumerator	Meaning
<code>_DeviceNXUnit</code>	NX Unit is specified.
<code>_DeviceEcatSlave</code>	EtherCAT slave is specified.
<code>_DeviceOptionBoard</code>	Option Board is specified.

In this instruction, you can specify `_DeviceOptionBoard`.

Use the *Kind* input variable to select the CS or DR signal.

The data type of *Kind* is enumerated type `_eSERIAL_SIG`.

The meanings of the enumerators of enumerated type `_eSERIAL_SIG` are as follows:

Enumerator	Meaning
<code>_RS_SIG</code>	RS signal
<code>_ER_SIG</code>	ER signal
<code>_CS_SIG</code>	CS signal
<code>_DR_SIG</code>	DR signal

Timing Charts

The following figures show the timing charts.

● Normal end

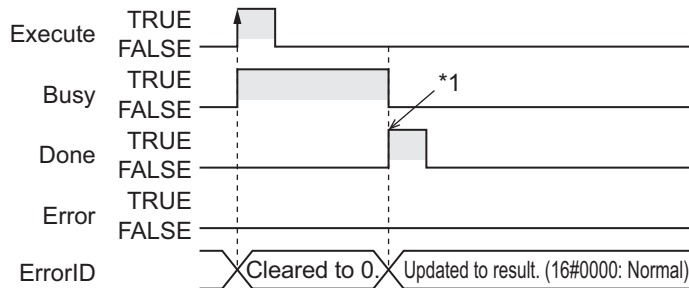

*1. Signal reading is completed.

● Error end

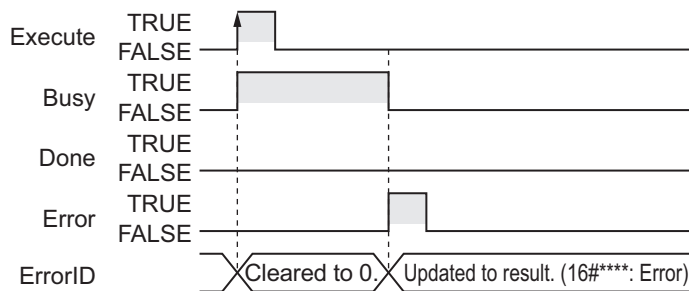

Related System-defined Variables

Name	Meaning	Data type	Description
_PLC_OptBoardSta	Option Board Status	ARRAY[1..2] of _sOPTBOARD_ STA	<ul style="list-style-type: none"> This stores the status of the Option Board.

Precautions for Correct Use

- Execution of this instruction is continued until processing is completed even if the value of *Execute* changes to FALSE or the execution time exceeds the task period. The value of *Done* changes to TRUE when processing is completed. Use this to confirm normal completion of processing.
- A compiling error will occur if you use this instruction in an event task. Do not use this instruction in event tasks.
- This instruction does not check the communications protocol and wiring conditions. Check the wiring conditions and communications protocol before you use this instruction.
- A CIF Unit Initialized error may occur when the NX-series Communications Interface Unit is restarted. Send or receive the data again, if necessary.
- If you use this instruction, do not assign device variables to any I/O ports that are indicated by “W” under the R/W column on the I/O Map Tab Page in the Sysmac Studio for the applicable NX-series Communications Interface Unit.
- An error will occur in the following cases. *Error* will change to TRUE.
 - A value that is out of range was set for *Kind*, *DevicePort.DevicePortType*, or *DevicePort.PortNo*.
 - The Unit, Option Board, or port specified with *DevicePort* does not exist.
 - An RS-422A/485 serial port is specified with *DevicePort*.
 - If more than 32 instructions from the NX_SerialSend instruction, NX_SerialRcv instruction, NX_ModbusRtuCmd instruction, NX_ModbusRtuRead instruction, NX_ModbusRtuWrite instruction, NX_SerialSigCtl instruction, NX_SerialSigRead instruction, NX_SerialStatusRead instruction, NX_SerialBufClear instruction, NX_SerialStartMon instruction and NX_SerialStopMon instruction are executed at the same time.
 - This instruction is executed with a device port variable that is the same as the one specified for the instruction which is still being executed. In this case, the instruction which is still being executed is one of the followings.
The NX_SerialSigCtl instruction, NX_SerialSigRead instruction, NX_SerialStatusRead instruction, NX_SerialBufClear instruction, NX_SerialStartMon instruction, and NX_SerialStopMon instruction.
 - Timeout time elapsed during serial communications.
 - The instruction is executed for other than Option Boards.
 - The serial communications mode of the specified Option Board is not *No-protocol* or *Modbus-RTU master*.

Sample Programming

Refer to the sample programming for *NX_SerialSigCtl* on page 2-1299.

NX_SerialStatusRead

The NX_SerialStatusRead instruction reads the status of a serial port on an Option Board.

Instruction	Name	FB/ FUN	Graphic expression	ST expression
NX_SerialStatusRead	Read Serial Port Status	FB		<pre>NX_SerialStatusRead_instance(Execute, DevicePort, TimeOut, Done, Busy, Error, ErrorID, PortStatus);</pre>



Precautions for Correct Use

You can use this instruction for an Option Board for the NX1P2 CPU Unit only.

Variables

Name	Meaning	I/O	Description	Valid range	Unit	Default
DevicePort	Device port	Input	Object that represents a device port	---	---	---
TimeOut	Timeout time		2.0 s when the timeout time is set to 0	Depends on data type.	0.1 s	0
PortStatus	Port status	Output	Outputs the port status that was read.	---	---	---

	Boolean	Bit strings				Integers							Real numbers	Times, durations, dates, and text strings							
	BOOL	BYTE	WORD	DWORD	LWORD	USINT	UINT	UDINT	ULINT	SINT	INT	DINT	LINT	REAL	LREAL	TIME	DATE	TOD	DT	STRING	
DevicePort																					
TimeOut							OK														
PortStatus																					

Function

The NX_SerialStatusRead instruction reads the status of a serial port on an Option Board.

The data type of the *DevicePort* input variable is structure `_sDEVICE_PORT`. The specifications are as follows:

Name	Meaning	Description	Data type	Valid range	Unit	Default
DevicePort	Device port	Object that represents a device port	<code>_sDEVICE_PORT</code>	---	---	---
DeviceType	Device type	Type of the device to specify	<code>_eDEVICE_TYPE</code>	<code>_DeviceNXUnit</code> <code>_DeviceEcatSlave</code> <code>_DeviceOptionBoard</code>	---	---
NxUnit	Specified Unit	NX Unit to control	<code>_sNXUNIT_ID</code>	---	---	---
EcatSlave	Specified slave	EtherCAT slave to control	<code>_sECAT_ID</code>	---	---	---
OptBoard	Specified Option Board	Option Board to control	<code>_sOPTBOARD_ID</code>	---	---	---
Reserved	Reserved	Reserved	Reserved	---	---	---
PortNo	Port number	Port number 1: Port 1 2: Port 2	USINT	Depends on data type.	---	---

Use *DeviceType* to specify the device type. For an Option Board, set this to `_DeviceOptionBoard`. The variable used to specify the device is determined by the specified device type.

To specify an Option Board, use *OptBoard* to specify the device. In this case, *NxUnit*, *EcatSlave*, and *Reserved* are not used.

To *OptBoard*, pass the device variable that is assigned to the node location information on the I/O Map for the device to specify.

If you use this instruction, be sure to assign a device variable to the node location information. Do not assign device variables to any I/O ports following the node location information that are indicated by “W” under the R/W column.

The figure below is an example of using this instruction for port 1 on an NX-CIF210.

The figure shows a screenshot of the Sysmac Studio I/O Map configuration. The top part shows the 'Node location information' for 'NX-CIF210' with a red arrow pointing to the 'Variable' column where 'N1_Node_location_information' is assigned. A red arrow labeled 'Assign a variable.' points to this assignment. Below this, a list of other ports (Ch1 Output SID, Ch1 Input SID Response, Ch1 Output Data Type, Ch1 Output Sub Info, Ch1 Output Data Length, Ch1 Output Data 01-05) is shown. A red arrow labeled 'Do not assign variables.' points to the empty 'Variable' column for these ports, indicating that variables should not be assigned to them.

Refer to the *Sysmac Studio Version 1 Operation Manual* (Cat. No. W504-E1-07 or later) for details on assigning a device variable to the node location information.

Use *PortNo* to specify the port number.

1: Port 1

2: Port 2

For an Option Board, set this to Port 1.

The data type of *DeviceType* is enumerated type `_eDEVICE_TYPE`.

The meanings of the enumerators of enumerated type `_eDEVICE_TYPE` are as follows:

Enumerator	Meaning
<code>_DeviceNXUnit</code>	NX Unit is specified.
<code>_DeviceEcatSlave</code>	EtherCAT slave is specified.
<code>_DeviceOptionBoard</code>	Option Board is specified.

In this instruction, you can specify `_DeviceOptionBoard`.

The data type of *PortStatus* output variable is structure `_sSERIAL_PORT_STATUS`. The specifications are as follows:

Name	Meaning	Description	Data type	Valid range	Unit	Default
PortStatus	Port status	Outputs the port status that was read.	<code>_sSERIAL_PORT_STATUS</code>	---	---	---
FullRcvBuf	Data discarded due to full receive buffer	TRUE: Data was discarded.*1 FALSE: Data was not discarded.	BOOL	Depends on data type.	---	---
Reserved	Reserved	Reserved	Reserved	---	---	---

*1 Data in the receive buffer may not be complete.

Timing Charts

The following figures show the timing charts.

● Normal end

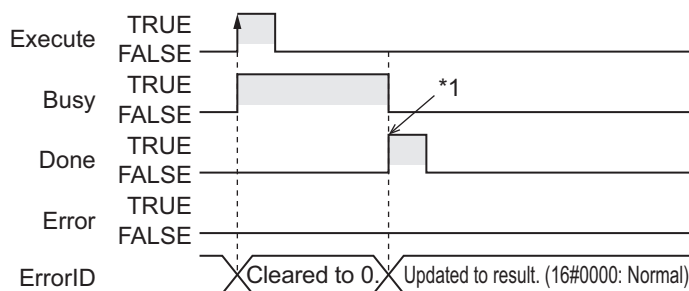

*1. Port status reading is completed.

● Error end

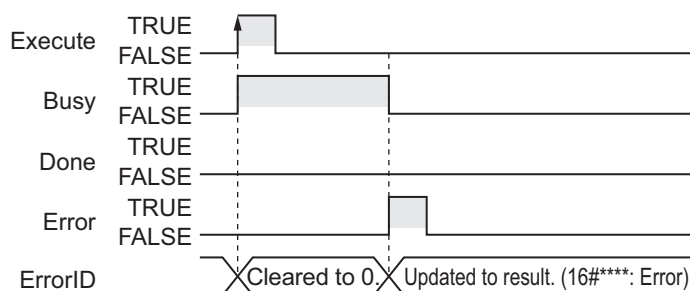

Related System-defined Variables

Name	Meaning	Data type	Description
_PLC_OptBoardSta	Option Board Status	ARRAY[1..2] of _sOPTBOARD_ STA	<ul style="list-style-type: none"> This stores the status of the Option Board.

Precautions for Correct Use

- Execution of this instruction is continued until processing is completed even if the value of *Execute* changes to FALSE or the execution time exceeds the task period. The value of *Done* changes to TRUE when processing is completed. Use this to confirm normal completion of processing.
- A compiling error will occur if you use this instruction in an event task. Do not use this instruction in event tasks.
- This instruction does not check the communication protocol and wiring conditions. Before use, check the wiring conditions and communication protocol.
- A CIF Unit Initialized error may occur when the NX-series Communications Interface Unit is restarted. Send or receive the data again, if necessary.
- If you use this instruction, do not assign device variables to any I/O ports that are indicated by “W” under the R/W column on the I/O Map Tab Page in the Sysmac Studio for the applicable NX-series Communications Interface Unit.
- An error will occur in the following cases. *Error* will change to TRUE.
 - A value that is out of range was set for *Kind*, *DevicePort.DevicePortType*, or *DevicePort.PortNo*.
 - The Unit, Option Board, or port specified with *DevicePort* does not exist.
 - If more than 32 instructions from the NX_SerialSend instruction, NX_SerialRcv instruction, NX_ModbusRtuCmd instruction, NX_ModbusRtuRead instruction, NX_ModbusRtuWrite instruction, NX_SerialSigCtl instruction, NX_SerialSigRead instruction, NX_SerialStatusRead instruction, NX_SerialBufClear instruction, NX_SerialStartMon instruction and NX_SerialStopMon instruction are executed at the same time.
 - This instruction is executed with a device port variable that is the same as the one specified for the instruction which is still being executed. In this case, the instruction which is still being executed is one of the followings.
NX_SerialSigCtl instruction, NX_SerialSigRead instruction, NX_SerialStatusRead instruction, NX_SerialBufClear instruction, NX_SerialStartMon instruction, and NX_SerialStopMon instruction.
 - Timeout time elapsed during serial communications.
 - The instruction is executed for other than Option Boards.
 - The serial communications mode of the specified Option Board is not *No-protocol* or *Modbus-RTU master*.

Sample Programming

Refer to the sample programming for *NX_SerialSigCtl* on page 2-1299.

NX_SerialBufClear

The NX_SerialBufClear instruction clears the send or receive buffer.

Instruction	Name	FB/ FUN	Graphic expression	ST expression
NX_SerialBufClear	Clear Buffer	FB		NX_SerialBufClear_instance(Execute DevicePort, BufKind, TimeOut, Done, Busy, Error, ErrorID);



Version Information

A CPU Unit with unit version 1.11 or later and Sysmac Studio version 1.15 or higher are required to use this instruction.

Variables

Name	Meaning	I/O	Description	Valid range	Unit	Default
DevicePort	Device port	Input	Object that represents a device port	---	---	---
BufKind	Buffer type		Type (send or receive) of buffer	_BUF_SENDRCV _BUF_SEND _BUF_RCV	---	_BUF-SENDRCV
TimeOut	Timeout time		2.0 s when the timeout time is set to 0	Depends on data type.	0.1 s	0

	Boolean	Bit strings				Integers							Real numbers		Times, durations, dates, and text strings						
	BOOL	BYTE	WORD	DWORD	LWORD	USINT	UINT	UDINT	ULINT	SINT	INT	DINT	LINT	REAL	LREAL	TIME	DATE	TOD	DT	STRING	
DevicePort																					
BufKind																					
TimeOut							OK														

Function

The NX_SerialBufClear clears data in a buffer according to the setting of type of the port and buffer. The instruction ends normally when the clear processing is completed.

The data type of the *DevicePort* input variable is structure `_sDEVICE_PORT`. The specifications are as follows:

Name	Meaning	Description	Data type	Valid range	Unit	Default
DevicePort	Device port	Object that represents a device port	<code>_sDEVICE_PORT</code>	---	---	---
DeviceType	Device type	Type of the device to specify	<code>_eDEVICE_TYPE</code>	<code>_DeviceNXUnit</code> <code>_DeviceEcatSlave</code> <code>_DeviceOptionBoard</code>	---	---
NxUnit	Specified Unit	NX Unit to control	<code>_sNXUNIT_ID</code>	---	---	---
EcatSlave	Specified slave	EtherCAT slave to control	<code>_sECAT_ID</code>	---	---	---
OptBoard	Specified Option Board	Option Board to control	<code>_sOPTBOARD_ID</code>	---	---	---
Reserved	Reserved	Reserved	Reserved	---	---	---
PortNo	Port number	Port number 1: Port 1 2: Port 2	USINT	Depends on data type.	---	---

Use *DeviceType* to specify the device type. Set this to `_DeviceNXUnit` for an NX Unit and `_DeviceOptionBoard` for an Option Board. The variable used to specify the device is determined by the specified device type.

To specify an NX Unit, use *NxUnit* to specify the device.

In this case, *EcatSlave* and *OptBoard* are not used.

To *NxUnit*, pass the device variable that is assigned to the node location information on the I/O Map for the device to specify.

To specify an Option Board, use *OptBoard* to specify the device.

In this case, *NxUnit* and *EcatSlave* are not used.

To *OptBoard*, pass the device variable that is assigned to the node location information on the I/O Map for the device to specify.

If you use this instruction, be sure to assign a device variable to the node location information. Do not assign device variables to any I/O ports following the node location information that are indicated by “W” under the R/W column.

The figure below is an example of using this instruction for port 1 on an NX-CIF210.

Assign a variable.

Position Unit1	Port	Description	R/W	Data Type	Variable
	▼ NX-CIF210				
	Node location information	Node location information	R	_sNXUNIT_ID	N1_Node_location_information
	⋮				
	Ch1 Output SID	Ch1 Output SID	W	USINT	
	Ch1 Input SID Response	Ch1 Input SID Response	W	USINT	
	▶ Ch1 Output Data Type	Ch1 Output Data Type	W	WORD	
	Ch1 Output Sub Info	Ch1 Output Sub Info	W	WORD	
	Ch1 Output Data Length	Ch1 Output Data Length	W	UINT	
	▶ Ch1 Output Data 01	Ch1 Output Data 01	W	ARRAY[0..3] OF BYTE	
	▶ Ch1 Output Data 02	Ch1 Output Data 02	W	ARRAY[0..3] OF BYTE	
	▶ Ch1 Output Data 03	Ch1 Output Data 03	W	ARRAY[0..3] OF BYTE	
	▶ Ch1 Output Data 04	Ch1 Output Data 04	W	ARRAY[0..3] OF BYTE	
	▶ Ch1 Output Data 05	Ch1 Output Data 05	W	ARRAY[0..3] OF BYTE	

Do not assign variables.

Refer to the *Sysmac Studio Version 1 Operation Manual* (Cat. No. W504-E1-07 or later) for details on assigning a device variable to the node location information.

Use *PortNo* to specify the port number.

1: Port 1

2: Port 2

For an NX Unit, set this to Port 1 or Port 2.

For an Option Board, set this to Port 1.

The data type of *DeviceType* is enumerated type `_eDEVICE_TYPE`.

The meanings of the enumerators of enumerated type `_eDEVICE_TYPE` are as follows:

Enumerator	Meaning
<code>_DeviceNXUnit</code>	NX Unit is specified.
<code>_DeviceEcatSlave</code>	EtherCAT slave is specified.
<code>_DeviceOptionBoard</code>	Option Board is specified.

In this instruction, you can specify `_DeviceNXUnit` or `_DeviceOptionBoard`.

Specify the port with *Port*, and specify the buffer to clear with *BufKind*.

Data is not cleared if it is the data that the NX-series Communications Interface Unit received from the external devices after the receive buffer is cleared.

The data type of *BufKind* is enumerated type `_eSERIAL_BUF_KIND`.

The meanings of the enumerators of enumerated type `_eSERIAL_BUF_KIND` are as follows:

Enumerator	Meaning
<code>_BUF_SENDRCV</code>	Send buffer and receive buffer
<code>_BUF_SEND</code>	Send buffer
<code>_BUF_RCV</code>	Receive buffer

An error occurs if this instruction is executed for Units other than NX-series Communications Interface Units and Option Boards.

Timing Charts

The following figures show the timing charts.

● Normal end

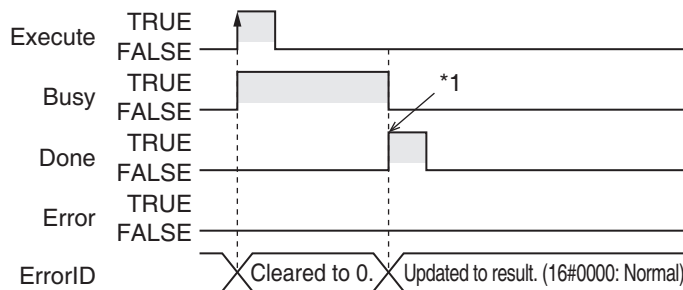

*1 Buffer clear processing is completed.

● Error end

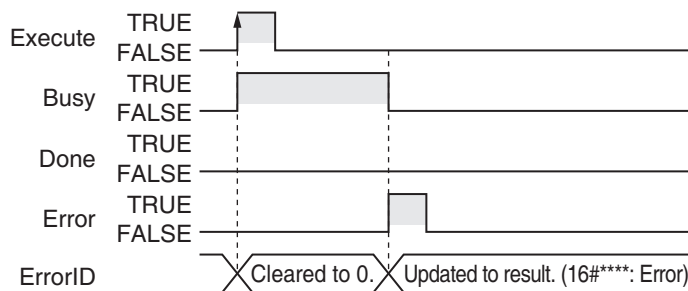

Related System-defined Variables

Name	Meaning	Data type	Description
<code>_PLC_OptBoardSta</code>	Option Board Status	ARRAY[1..2] of <code>_sOPTBOARD_STA</code>	<ul style="list-style-type: none"> This stores the status of the Option Board.
<code>_NXB_UnitIOActiveTbl</code>	NX Unit I/O Data Active Status	ARRAY[0..8] OF BOOL	<ul style="list-style-type: none"> This status tells the NX Units whether I/O data communications can be processed. The subscript of the array corresponds to the NX Unit numbers. A subscript of 0 means the NX bus master.

Precautions for Correct Use

- Execution of this instruction is continued until processing is completed even if the value of *Execute* changes to FALSE or the execution time exceeds the task period. The value of *Done* changes to TRUE when processing is completed. Use this to confirm normal completion of processing.
- A compiling error will occur if you use this instruction in an event task. Do not use this instruction in event tasks.
- This instruction does not check the communication protocol and wiring conditions. Before use, check the wiring conditions and communication protocol.
- A CIF Unit Initialized error may occur when the NX-series Communications Interface Unit is restarted. Send or receive the data again, if necessary.
- If you use this instruction, do not assign device variables to any I/O ports that are indicated by “W” under the R/W column on the I/O Map Tab Page in the Sysmac Studio for the applicable NX-series Communications Interface Unit.
- An error will occur in the following cases. *Error* will change to TRUE.
 - A value that is out of range was set for *BufKind*, *DevicePort.DevicePortType*, or *DevicePort.PortNo*.
 - The Unit, Option Board, or port specified with *DevicePort* does not exist.
 - If more than 32 instructions from the NX_SerialSend instruction, NX_SerialRcv instruction, NX_ModbusRtuCmd instruction, NX_ModbusRtuRead instruction, NX_ModbusRtuWrite instruction, NX_SerialSigCtl instruction, NX_SerialSigRead instruction, NX_SerialStatusRead instruction, NX_SerialBufClear instruction, NX_SerialStartMon instruction and NX_SerialStopMon instruction are executed at the same time.
 - This instruction is executed with a device port variable that is the same as the one specified for the instruction which is still being executed. In this case, the instruction which is still being executed is one of the followings.
The NX_SerialSend instruction, NX_SerialRcv instruction, NX_ModbusRtuCmd instruction, NX_ModbusRtuRead instruction, NX_ModbusRtuWrite instruction, NX_SerialSigCtl instruction, NX_SerialSigRead instruction, NX_SerialStatusRead instruction, NX_SerialBufClear instruction, NX_SerialStartMon instruction, and NX_SerialStopMon instruction.
 - Timeout time elapsed during serial communications.
 - This instruction is executed for Units other than NX-series Communications Interface Units and Option Boards.
 - The serial communications mode of the specified Option Board is not *No-protocol* or *Modbus-RTU master*.

Sample Programming

In this sample, an NX-series Communications Interface Unit (NX-CIF210) is connected to an EtherCAT Coupler Unit (NX-ECC203).

The unit number of the NX-CIF210 is set to 1.

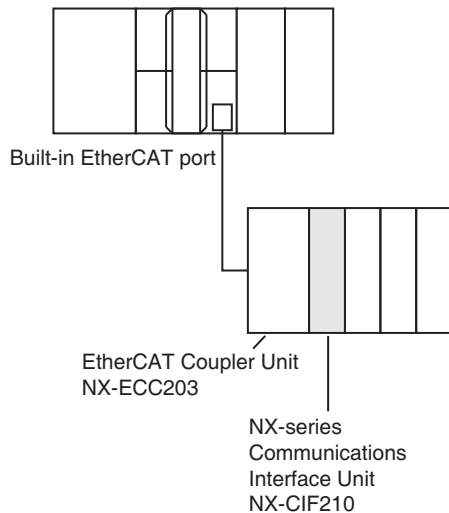

This instruction clears the receive buffer of serial port 2 on NX-CIF210. When clear processing is completed, the instruction waits for data that does not have start code and has the CR end code.

Definitions of Global Variables

Global Variables

Name	Data type	AT	Comment
E001_NX_Unit_I_O_Data_Active_Status_63	ARRAY[0..63] OF BOOL	ECAT://node#1/NX Unit I/O Data Active Status 125	Usage of I/O data for 63 NX Units.
N1_Node_location_information	_sNXUNIT_ID	---	Device variable to specify NX-CIF210*1

*1 On the Sysmac Studio, right-click an NX-series slave terminal unit, select **Display Node Location Port**, and set the device variable. Refer to the *Sysmac Studio Version 1 Operation Manual* (Cat. No. W504-E1-07 or later) for details.

LD

Internal Variables	Variable	Data type	Initial value	Comment
	OperatingEnd	BOOL	FALSE	Buffer clear processing finished
	Trigger	BOOL	FALSE	Buffer clear execution condition
	Operating	BOOL	FALSE	Buffer clear processing in progress
	SelectSendBuf	BOOL	FALSE	Send buffer selection
	SelectRcvBuf	BOOL	FALSE	Receive buffer selection
	BufKind	_eSERIAL_BUF_KIND	_BUF_SENDRCV	Buffer setting
	DevicePort	_sDEVICE_PORT		Port settings
	NX_SerialBuf-Clear_instance	NX_SerialBufClear	---	
	RcvingEnd	BOOL		Receive processing completed
	Rcving	BOOL		Receive processing in progress
	RcvCfg	_sSERIAL_CFG		Reception completion setting
	StartTrig	_eSERIAL_START	_SERIAL_START_NONE	
	StartCode	ARRAY[0..1] OF BYTE	[2(16#0)]	
	EndTrig	_eSERIAL_END	_SERIAL_END_CODE1	
	EndCode	ARRAY[0..1] OF BYTE	[16#0D,16#00]	End code: CR
	RcvSizeCfg	UINT	0	
	Option	_sSERIAL_RCV_OPTION		
	TimeOut	TIME	TIME#0s	
	LastDatRcv	BOOL	FALSE	
	ClearBuf	BOOL	FALSE	

External Variables	Variable	Data type	Comment
	E001_NX_Unit_I_O_Data_Active_Status_63	ARRAY[0..63] OF BOOL	<ul style="list-style-type: none"> Usage of I/O data for 63 NX Units. If the relevant Unit number is 1, E001_NX_Unit_I_O_Data_Active_Status_63[1] is used.
	N1_Node_location_information	_sNXUNIT_ID	Device variable to specify NX-CIF210

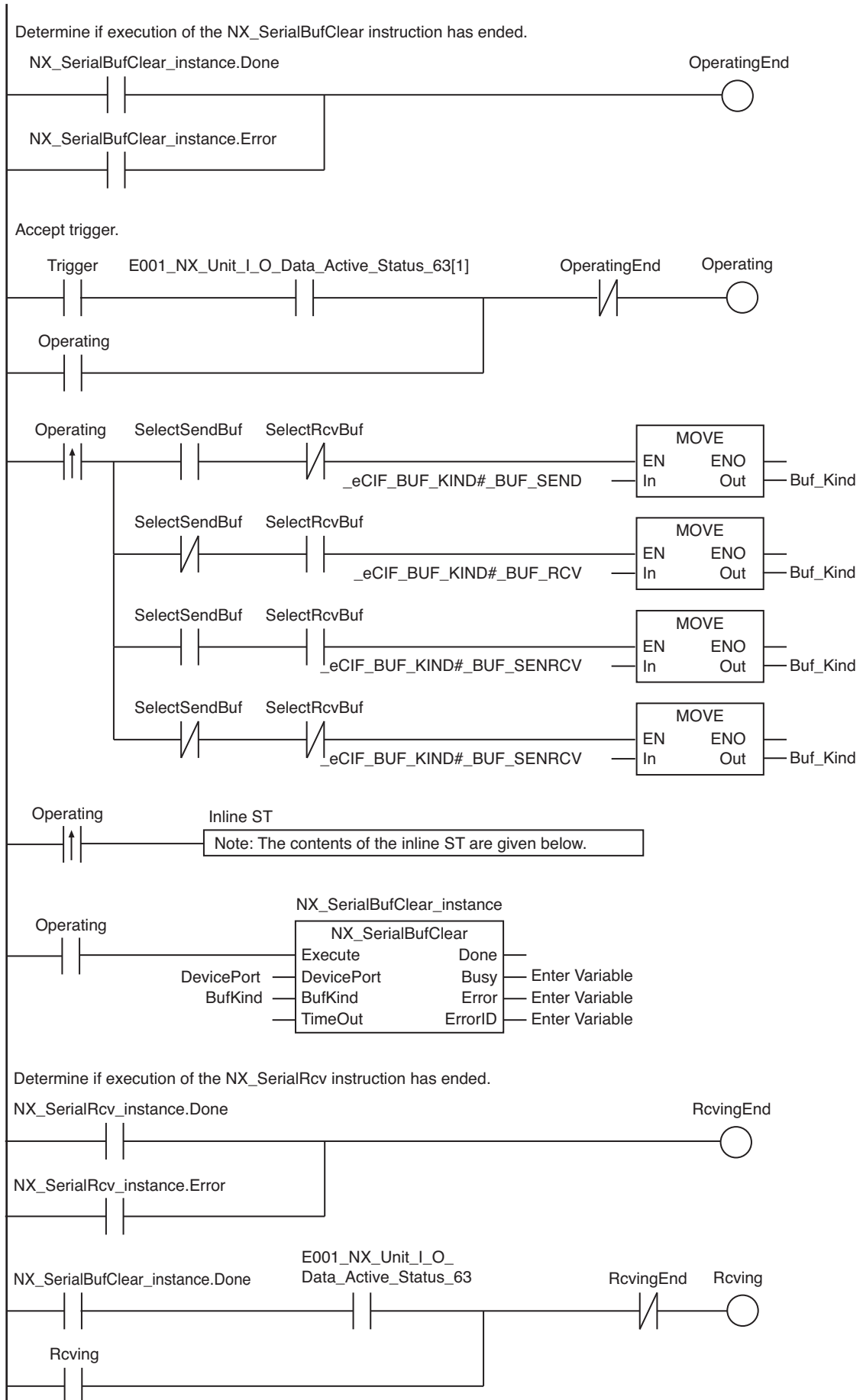

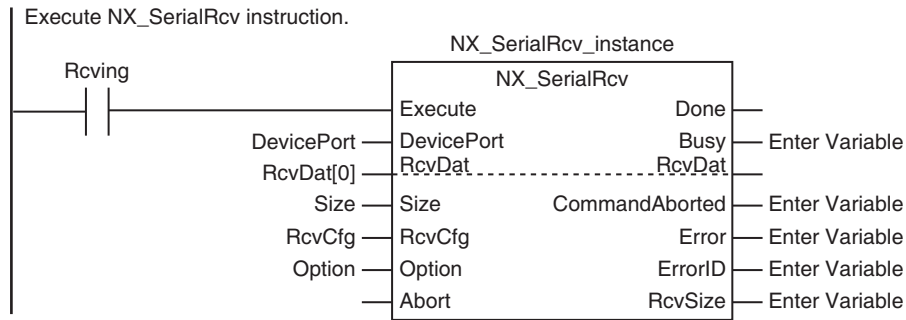

● Contents of Inline ST

```
DevicePort.DeviceType:=_eDEVICE_TYPE#_DeviceNXUnit;
DevicePort.NxUnit:=N1_Node_location_information;
DevicePort.PortNo:=2;
```

ST

Internal Variables	Variable	Data type	Initial value	Comment
	OperatingEnd	BOOL	FALSE	Buffer clear processing finished
	Trigger	BOOL	FALSE	Buffer clear execution condition
	Operating	BOOL	FALSE	Buffer clear processing in progress
	SelectSendBuf	BOOL	FALSE	Send buffer selection
	SelectRcvBuf	BOOL	FALSE	Receive buffer selection
	BufKind	_eSERIAL_BUF_KIND	_BUF_SENDRCV	Buffer setting
	DevicePort	_sDEVICE_PORT		Port settings
	NX_SerialBuf-Clear_instance	NX_SerialBufClear	---	
	RcvingEnd	BOOL		Receive processing completed
	Rcving	BOOL		Receive processing in progress
	RcvCfg	_sSERIAL_CFG		Reception completion setting
	StartTrig	_eSERIAL_START	_SERIAL_START_NONE	
	StartCode	ARRAY[0..1] OF BYTE	[2(16#0)]	
	EndTrig	_eSERIAL_END	_SERIAL_END_CODE1	
	EndCode	ARRAY[0..1] OF BYTE	[16#0D,16#00]	End code: CR
	RcvSizeCfg	UINT	0	
	Option	_sSERIAL_RCV_OPTION		
	TimeOut	TIME	TIME#0s	
	LastDatRcv	BOOL	FALSE	
	ClearBuf	BOOL	FALSE	

External Variables	Variable	Data type	Comment
	E001_NX_Unit_I_O_Data_Active_Status_63	ARRAY[0..63] OF BOOL	<ul style="list-style-type: none"> Usage of I/O data for 63 NX Units. If the relevant Unit number is 1, E001_NX_Unit_I_O_Data_Active_Status_63[1] is used.
	N1_Node_location_information	_sNXUNIT_ID	Device variable to specify NX-CIF210

```

// Condition setting
RS_instancel(Set:=Trigger AND E001_NX_Unit_I_O_Data_Active_Status_63[1]
             Reset1:=OperatingEnd,
             Q1=>Operating);
R_Trigger_instance(Clk:=Operating);
IF ( (R_Trigger_instance.Q=TRUE) ) THEN
    DevicePort.DeviceType:=_eDEVICE_TYPE#_DeviceNXUnit;
    DevicePort.NxUnit:=N1_Node_location_information;
    DevicePort.PortNo:=2;
    IF( (SelectSendBuf=TRUE) THEN
        IF(SelectRcvBuf=TRUE) THEN
            BufKind:=_eSERIAL_BUF_KIND#_BUF_SENDRCV;
        ELSE
            BufKind:=_eSERIAL_BUF_KIND#_BUF_SEND;
        END_IF;
    ELSE
        IF (SelectRcvBuf=TRUE) THEN
            BufKind:=_eSERIAL_BUF_KIND#_BUF_RCV;
        ELSE
            BufKind:=_eSERIAL_BUF_KIND#_BUF_SENDRCV;
        END_IF
    END_IF;
END_IF;

// Execute buffer clear
NX_SerialBufClear_instance(Execute:=Operating,
                           DevicePort:=DevicePort,
                           BufKind:=BufKind);

//
RS_instane2(Set:=NX_SerialBufClear.Done AND
            E001_NX_Unit_I_O_Data_Active_Status_63[1],
            Reset1:=NX_SerialRcv_instance.Done OR NX_SerialRcv_instance.Error,
            Q1=>Rcving);

//
NX_SerialRcv_instance(Execute:=Rcving,
                     DevicePort:=DevicePort,
                     RcvDat:=RcvDat[0],
                     Size:=Size,
                     RcvCfg:=RcvCfg,
                     Option:=Option);

```

NX_SerialStartMon

The NX_SerialStartMon instruction starts serial line monitoring of an NX-series Communications Interface Unit.

Instruction	Name	FB/ FUN	Graphic expression	ST expression
NX_SerialStartMon	Start Serial Line Monitoring	FB		<pre>NX_SerialStartMon_instance(Execute, DevicePort, Continuous, TimeOut, Done, Busy, Error, ErrorID);</pre>



Precautions for Correct Use

You cannot use this instruction for an Option Board for the NX1P2 CPU Unit.



Version Information

A CPU Unit with unit version 1.11 or later and Sysmac Studio version 1.15 or higher are required to use this instruction.

Variables

Name	Meaning	I/O	Description	Valid range	Unit	Default
DevicePort	Device port	Input	Object that represents a device port	---	---	---
Continuous	Continuous monitoring		Serial line monitor operation method TRUE: Continuous FALSE: One-shot	Depends on data type.	---	FALSE
TimeOut	Timeout time		2.0 s when the timeout time is set to 0	Depends on data type.	0.1 s	0

	Boolean	Bit strings				Integers								Real numbers	Times, durations, dates, and text strings						
	BOOL	BYTE	WORD	DWORD	LWORD	USINT	UINT	UDINT	ULINT	SINT	INT	DINT	LINT	REAL	LREAL	TIME	DATE	TOD	DT	STRING	
DevicePort																					
Continuous	OK																				
TimeOut							OK														

Function

The NX_SerialStartMon instruction starts serial line monitoring of an NX-series Communications Interface Unit.

This instruction ends normally after serial line monitoring starts.

The data type of the *DevicePort* input variable is structure `_sDEVICE_PORT`. The specifications are as follows:

Variables	Meaning	Description	Data type	Valid range	Unit	Default
DevicePort	Device port	Object that represents a device port	<code>_sDEVICE_PORT</code>	---	---	---
DeviceType	Device type	Type of the device to specify	<code>_eDEVICE_TYPE</code>	<code>_DeviceNXUnit</code> <code>_DeviceEcatSlave</code> <code>_DeviceOptionBoard</code>	---	---
NxUnit	Specified Unit	NX Unit to control	<code>_sNXUNIT_ID</code>	---	---	---
EcatSlave	Specified slave	EtherCAT slave to control	<code>_sECAT_ID</code>	---	---	---
OptBoard	Specified Option Board	Option Board to control	<code>_sOPTBOARD_ID</code>	---	---	---
Reserved	Reserved	Reserved	Reserved	---	---	---
PortNo	Port number	Port number 1: Port 1 2: Port 2	USINT	Depends on data type.	---	---

Use *DeviceType* to specify the device type. Set this to `_DeviceNXUnit` for an NX Unit. The variable used to specify the device is determined by the specified device type.

In this instruction, *NxUnit* is used to specify the device. *EcatSlave* and *OptBoard* are not used.

To *NxUnit*, pass the device variable that is assigned to the node location information on the I/O Map for the device to specify.

If you use this instruction, be sure to assign a device variable to the node location information. Do not assign device variables to any I/O ports following the node location information that are indicated by “W” under the R/W column.

The figure below is an example of using this instruction for port 1 on an NX-CIF210.

Assign a variable.

Position Unit1	Port	Description	R/W	Data Type	Variable
	▼ NX-CIF210				
	Node location information	Node location information	R	_sNXUNIT_ID	N1_Node_location_information
	⋮				
	Ch1 Output SID	Ch1 Output SID	W	USINT	
	Ch1 Input SID Response	Ch1 Input SID Response	W	USINT	
	▶ Ch1 Output Data Type	Ch1 Output Data Type	W	WORD	
	Ch1 Output Sub Info	Ch1 Output Sub Info	W	WORD	
	Ch1 Output Data Length	Ch1 Output Data Length	W	UINT	
	▶ Ch1 Output Data 01	Ch1 Output Data 01	W	ARRAY[0..3] OF BYTE	
	▶ Ch1 Output Data 02	Ch1 Output Data 02	W	ARRAY[0..3] OF BYTE	
	▶ Ch1 Output Data 03	Ch1 Output Data 03	W	ARRAY[0..3] OF BYTE	
	▶ Ch1 Output Data 04	Ch1 Output Data 04	W	ARRAY[0..3] OF BYTE	
	▶ Ch1 Output Data 05	Ch1 Output Data 05	W	ARRAY[0..3] OF BYTE	

Do not assign variables.

Refer to the *Sysmac Studio Version 1 Operation Manual* (Cat. No. W504-E1-07 or later) for details on assigning a device variable to the node location information.

Use *PortNo* to specify the port number.

- 1: Port 1
- 2: Port 2

The data type of *DeviceType* is enumerated type `_eDEVICE_TYPE`.

The meanings of the enumerators of enumerated type `_eDEVICE_TYPE` are as follows:

Enumerator	Meaning
<code>_DeviceNXUnit</code>	NX Unit is specified.
<code>_DeviceEcatSlave</code>	EtherCAT slave is specified.
<code>_DeviceOptionBoard</code>	Option Board is specified.

In this instruction, you can specify `_DeviceNXUnit`.

When the *Continuous* input variable is TRUE, continuous monitoring is selected and the monitoring is continued until the `NX_SerialStopMon` instruction is executed.

When the *Continuous* input variable is FALSE, one-shot monitoring is selected and serial line monitoring is continued until the buffer becomes full or the `NX_SerialStopMon` instruction is executed.

An error occurs if this instruction is executed for Units other than NX-series Communications Interface Units.

Timing Charts

The following figures show the timing charts.

● Normal end

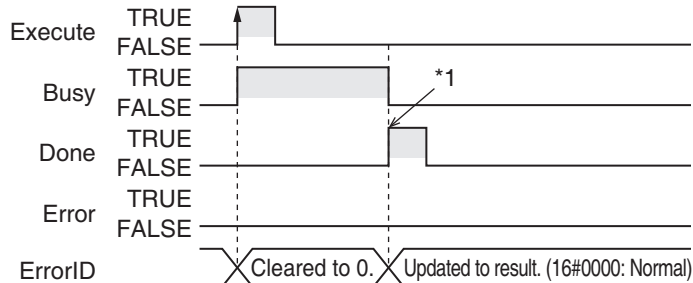

*1 Serial line monitoring is started.

● Error end

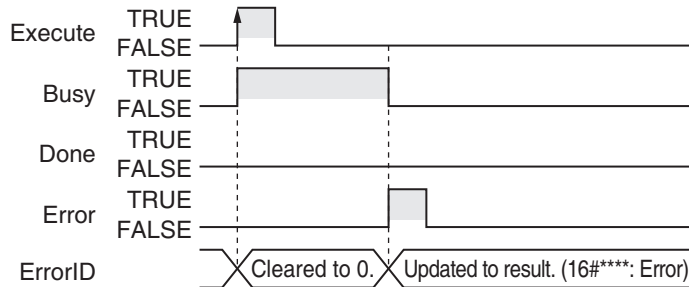

Related System-defined Variables

Name	Meaning	Data type	Description
_NXB_UnitIOActiveTbl	NX Unit I/O Data Active Status	ARRAY[0..8] OF BOOL	<ul style="list-style-type: none"> This status tells the NX Units whether I/O data communications can be processed. The subscript of the array corresponds to the NX Unit numbers. A subscript of 0 means the NX bus master.

Precautions for Correct Use

- Execution of this instruction is continued until processing is completed even if the value of *Execute* changes to FALSE or the execution time exceeds the task period. The value of *Done* changes to TRUE when processing is completed. Use this to confirm normal completion of processing.
- A compiling error will occur if you use this instruction in an event task. Do not use this instruction in event tasks.
- A CIF Unit Initialized error may occur when the NX-series Communications Interface Unit is restarted. Send or receive the data again, if necessary.
- If you use this instruction, do not assign device variables to any I/O ports that are indicated by “W” under the R/W column on the I/O Map Tab Page in the Sysmac Studio for the applicable NX-series Communications Interface Unit.
- An error will occur in the following cases. *Error* will change to TRUE.
 - A value that is out of range was set for *DevicePort.DevicePortType* or *DevicePort.PortNo*.
 - The Unit, Option Board, or port specified with *DevicePort* does not exist.
 - If more than 32 instructions from the NX_SerialSend instruction, NX_SerialRcv instruction, NX_ModbusRtuCmd instruction, NX_ModbusRtuRead instruction, NX_ModbusRtuWrite instruction, NX_SerialSigCtl instruction, NX_SerialSigRead instruction, NX_SerialStatusRead instruction, NX_SerialBufClear instruction, NX_SerialStartMon instruction and NX_SerialStopMon instruction are executed at the same time.
 - This instruction is executed with a device port variable that is the same as the one specified for the instruction which is still being executed. In this case, the instruction which is still being executed is one of the followings.
The NX_SerialSigCtl instruction, NX_SerialSigRead instruction, NX_SerialStatusRead instruction, NX_SerialBufClear instruction, NX_SerialStartMon instruction, and NX_SerialStopMon instruction.
 - Timeout time elapsed during serial communications.
 - This instruction is executed for Units other than NX-series Communications Interface Units and Option Boards.

NX_SerialStopMon

The NX_SerialStopMon instruction stops serial line monitoring of an NX-series Communications Interface Unit.

Instruction	Name	FB/ FUN	Graphic expression	ST expression
NX_SerialStopMon	Stop Serial Line Monitoring	FB		<pre>NX_SerialStopMon_instance(Execute, DevicePort, TimeOut, Done, Busy, Error, ErrorID);</pre>



Precautions for Correct Use

You cannot use this instruction for an Option Board for the NX1P2 CPU Unit.



Version Information

A CPU Unit with unit version 1.11 or later and Sysmac Studio version 1.15 or higher are required to use this instruction.

Variables

Name	Meaning	I/O	Description	Valid range	Unit	Default
DevicePort	Device port	Input	Object that represents a device port	---	---	---
TimeOut	Timeout time		2.0 s when the timeout time is set to 0	Depends on data type.	0.1 s	0

	Boolean	Bit strings				Integers							Real numbers	Times, durations, dates, and text strings							
	BOOL	BYTE	WORD	DWORD	LWORD	USINT	UINT	UDINT	ULINT	SINT	INT	DINT	LINT	REAL	LREAL	TIME	DATE	TOD	DT	STRING	
DevicePort																					Refer to <i>Function</i> for details on the structure <code>_sDEVICE_PORT</code> .
TimeOut							OK														

Function

The NX_SerialStopMon instruction stops serial line monitoring of an NX-series Communications Interface Unit.

This instruction ends normally after serial line monitoring stops.

The data type of the *DevicePort* input variable is structure `_sDEVICE_PORT`. The specifications are as follows:

Variables	Meaning	Description	Data type	Valid range	Unit	Default
DevicePort	Device port	Object that represents a device port	<code>_sDEVICE_PORT</code>	---	---	---
DeviceType	Device type	Type of the device to specify	<code>_eDEVICE_TYPE</code>	<code>_DeviceNXUnit</code> <code>_DeviceEcatSlave</code> <code>_DeviceOptionBoard</code>	---	---
NxUnit	Specified Unit	NX Unit to control	<code>_sNXUNIT_ID</code>	---	---	---
EcatSlave	Specified slave	EtherCAT slave to control	<code>_sECAT_ID</code>	---	---	---
OptBoard	Specified Option Board	Option Board to control	<code>_sOPTBOARD_ID</code>	---	---	---
Reserved	Reserved	Reserved	Reserved	---	---	---
PortNo	Port number	Port number 1: Port 1 2: Port 2	USINT	Depends on data type.	---	---

Use *DeviceType* to specify the device type. Set this to `_DeviceNXUnit` for an NX Unit. The variable used to specify the device is determined by the specified device type.

In this instruction, *NxUnit* is used to specify the device. *EcatSlave* and *OptBoard* are not used.

To *NxUnit*, pass the device variable that is assigned to the node location information on the I/O Map for the device to specify.

If you use this instruction, be sure to assign a device variable to the node location information. Do not assign device variables to any I/O ports following the node location information that are indicated by “W” under the R/W column.

The figure below is an example of using this instruction for port 1 on an NX-CIF210.

Position	Port	Description	R/W	Data Type	Variable
Unit1	▼ NX-CIF210	Node location information	R	<code>_sNXUNIT_ID</code>	<code>N1_Node_location_information</code>
		⋮			
		Ch1 Output SID	W	USINT	
		Ch1 Input SID Response	W	USINT	
		▶ Ch1 Output Data Type	W	WORD	
		Ch1 Output Sub Info	W	WORD	
		Ch1 Output Data Length	W	UINT	
		▶ Ch1 Output Data 01	W	ARRAY[0..3] OF BYTE	
		▶ Ch1 Output Data 02	W	ARRAY[0..3] OF BYTE	
		▶ Ch1 Output Data 03	W	ARRAY[0..3] OF BYTE	
		▶ Ch1 Output Data 04	W	ARRAY[0..3] OF BYTE	
		▶ Ch1 Output Data 05	W	ARRAY[0..3] OF BYTE	

Assign a variable.

Do not assign variables.

Refer to the *Sysmac Studio Version 1 Operation Manual* (Cat. No. W504-E1-07 or later) for details on assigning a device variable to the node location information.

Use *PortNo* to specify the port number.

- 1: Port 1
- 2: Port 2

The data type of *DeviceType* is enumerated type `_eDEVICE_TYPE`.

The meanings of the enumerators of enumerated type `_eDEVICE_TYPE` are as follows:

Enumerator	Meaning
<code>_DeviceNXUnit</code>	NX Unit is specified.
<code>_DeviceEcatSlave</code>	EtherCAT slave is specified.
<code>_DeviceOptionBoard</code>	Option Board is specified.

In this instruction, you can specify `_DeviceNXUnit`.

An error occurs if this instruction is executed for Units other than NX-series Communications Interface Units.

Timing Charts

The following figures show the timing charts.

● Normal end

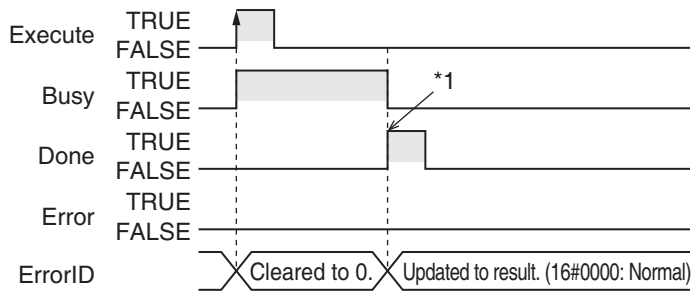

● Error end

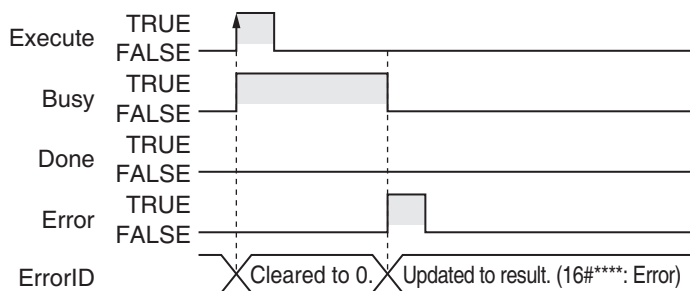

Related System-defined Variables

Name	Meaning	Data type	Description
_NXB_UnitIOActiveTbl	NX Unit I/O Data Active Status	ARRAY[0..8] OF BOOL	<ul style="list-style-type: none"> This status tells the NX Units whether I/O data communications can be processed. The subscript of the array corresponds to the NX Unit numbers. A subscript of 0 means the NX bus master.

Precautions for Correct Use

- Execution of this instruction is continued until processing is completed even if the value of *Execute* changes to FALSE or the execution time exceeds the task period. The value of *Done* changes to TRUE when processing is completed. Use this to confirm normal completion of processing.
- A compiling error will occur if you use this instruction in an event task. Do not use this instruction in event tasks.
- A CIF Unit Initialized error may occur when the NX-series Communications Interface Unit is restarted. Send or receive the data again, if necessary.
- If you use this instruction, do not assign device variables to any I/O ports that are indicated by “W” under the R/W column on the I/O Map Tab Page in the Sysmac Studio for the applicable NX-series Communications Interface Unit.
- An error will occur in the following cases. *Error* will change to TRUE.
 - A value that is out of range was set for *DevicePort.DevicePortType* or *DevicePort.PortNo*.
 - The Unit, Option Board, or port specified with *DevicePort* does not exist.
 - If more than 32 instructions from the NX_SerialSend instruction, NX_SerialRcv instruction, NX_ModbusRtuCmd instruction, NX_ModbusRtuRead instruction, NX_ModbusRtuWrite instruction, NX_SerialSigCtl instruction, NX_SerialSigRead instruction, NX_SerialStatusRead instruction, NX_SerialBufClear instruction, NX_SerialStartMon instruction and NX_SerialStopMon instruction are executed at the same time.
 - This instruction is executed with a device port variable that is the same as the one specified for the instruction which is still being executed. In this case, the instruction which is still being executed is one of the followings.
The NX_SerialSigCtl instruction, NX_SerialSigRead instruction, NX_SerialStatusRead instruction, NX_SerialBufClear instruction, NX_SerialStartMon instruction, and NX_SerialStopMon instruction.
 - Timeout time elapsed during serial communications.
 - This instruction is executed for Units other than NX-series Communications Interface Units and Option Boards.

SD Memory Card Instructions

Instruction	Name	Page
FileWriteVar	Write Variable to File	2-1338
FileReadVar	Read Variable from File	2-1343
FileOpen	Open File	2-1348
FileClose	Close File	2-1352
FileSeek	Seek File	2-1355
FileRead	Read File	2-1359
FileWrite	Write File	2-1367
FileGets	Get Text String	2-1375
FilePuts	Put Text String	2-1383
FileCopy	Copy File	2-1392
FileRemove	Delete File	2-1401
FileRename	Change File Name	2-1406
DirCreate	Create Directory	2-1411
DirRemove	Delete Directory	2-1414
BackupToMemoryCard	SD Memory Card Backup	2-1417

FileWriteVar

The FileWriteVar instruction writes the value of a variable to the specified file in the SD Memory Card. The value is written in binary format.

Instruction	Name	FB/FUN	Graphic expression	ST expression
FileWriteVar	Write Variable to File	FB		FileWriteVar_instance(Execute, FileName, WriteVar, OverWrite, Done, Busy, Error, ErrorID);

Variables

Name	Meaning	I/O	Description	Valid range	Unit	Default
FileName	File name	Input	Name of file to which to write variable	66 bytes max. (65 single-byte alphanumeric characters plus the final NULL character)	---	"
WriteVar	Variable		Variable to write	Depends on data type.		*
OverWrite	Overwrite enable		TRUE: Enable overwrite. FALSE: Prohibit overwrite.			FALSE

* If you omit the input parameter, the default value is not applied. A building error will occur.

	Boolean	Bit strings					Integers							Real numbers	Times, durations, dates, and text strings						
	BOOL	BYTE	WORD	DWORD	LWORD	USINT	UINT	UDINT	ULINT	SINT	INT	DINT	LINT	REAL	LREAL	TIME	DATE	TOD	DT	STRING	
FileName																				OK	
WriteVar	OK	OK	OK	OK	OK	OK	OK	OK	OK	OK	OK	OK	OK	OK	OK	OK	OK	OK	OK	OK	OK
	An enumeration, array, array element, structure, or structure member can also be specified.																				
OverWrite	OK																				

Function

The FileWriteVar instruction writes the value of variable *WriteVar* to the file specified by *FileName* in the SD Memory Card. The value is written in binary format. You can specify an enumeration, array, array element, structure, or structure member for *WriteVar*.

If a file with the name *FileName* does not exist on the SD Memory Card, it is created. *FileName* includes the path. If a specified directory does not exist in the SD Memory Card, it is created. However, the directory is created only when only the lowest directory level of the specified path does not exist.

If a file with the name *FileName* already exists in the SD Memory Card, the following processing is performed depending on the value of overwrite enable *OverWrite*.

Value of <i>OverWrite</i>	Processing
TRUE (Enable overwrite.)	The existing file is overwritten.
FALSE (Prohibit overwrite.)	The file is not overwritten and an error occurs.

The following figure shows a programming example. The contents of array variable abc[0] is written to a file named 'Temp/f_name.bin.' Variable abc is an INT array variable with three elements.

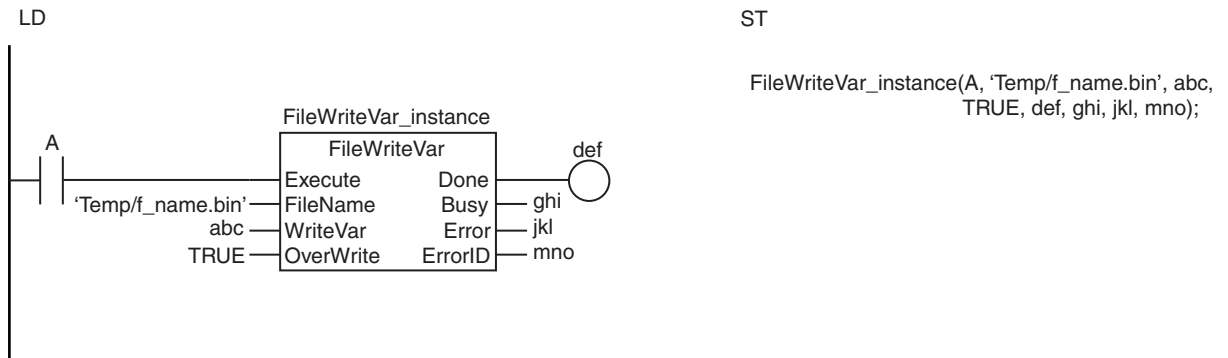

```
FileWriteVar_instance(A, 'Temp/f_name.bin', abc,
TRUE, def, ghi, jkl, mno);
```

The FileWriteVar instruction writes the value of variable WriteVar to the file specified by FileName in the SD Memory Card. The value is written in binary format.

File FileName = 'Temp/f_name.bin'

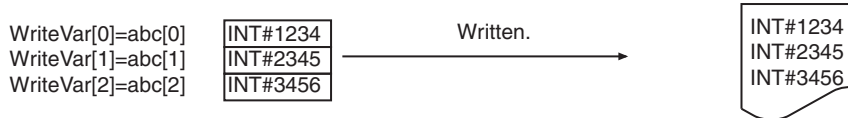

Related System-defined Variables

Name	Meaning	Data type	Description
_Card1Ready	SD Memory Card Ready Flag	BOOL	This flag indicates if the SD Memory Card can be accessed by instructions and communications commands.*1 TRUE: Can be used. FALSE: Cannot be used.
_Card1Protect*2	SD Memory Card Write Protected Flag	BOOL	This flag indicates if the SD Memory Card is write protected when it is inserted and ready to use. TRUE: Write protected. FALSE: Not write protected.
_Card1Err*2	SD Memory Card Error Flag	BOOL	This flag indicates if an unspecified SD Memory Card (e.g., an SDHC card) is mounted or if the format is incorrect (i.e., not FAT16 or corrupted). TRUE: Error. FALSE: No error.
_Card1Access*2	SD Memory Card Access Flag	BOOL	This flag indicates if the SD Memory Card is currently being accessed. TRUE: Being accessed. FALSE: Not being accessed.
_Card1PowerFail	SD Memory Card Power Interruption Flag	BOOL	This flag indicates if an error occurred in completing processing when power was interrupted during access*3. This flag is not cleared automatically. TRUE: Error. FALSE: No error.

*1 For the NJ/NX-series, it is a precondition that the SD Memory Card is physically inserted and mounted normally. For an NY-series Controller, it is a precondition that the shared folder is detected by the Controller.

*2 These variables are not used for the NY-series Controller. They are fixed to FALSE.

*3 For the NJ/NX-series, this indicates an access to the SD Memory Card. For an NY-series Controller, this indicates an access to the shared folder.

Additional Information

The root directory of the file name is the top level of the SD Memory Card.

Precautions for Correct Use

- Execution of this instruction is continued until processing is completed even if the value of *Execute* changes to FALSE or the execution time exceeds the task period. The value of *Done* changes to TRUE when processing is completed. Use this to confirm normal completion of processing.
- Refer to *Using this Section* on page 2-3 for a timing chart for *Execute*, *Done*, *Busy*, and *Error*.
- Always use a variable for the input parameter to pass to *WriteVar*. A building error will occur if a constant is passed.
- If *WriteVar* is an enumeration, you cannot directly pass an enumerator to it. A building error will occur if an enumerator is passed to it directly.
- If the specified file is larger than the size of *WriteVar*, an error does not occur and only data that corresponds to the size of *WriteVar* is written. Once this instruction is executed, the specified file is reduced to the size of *WriteVar*.
- Data is written in byte increments. The lower bytes are written before the upper bytes (little endian).
- If *WriteVar* is a structure, adjustment areas between members may be inserted depending on the composition.
- Do not simultaneously access the same file. Perform exclusive control of SD Memory Card instructions in the user program.
- An error occurs in the following cases. *Error* will change to TRUE.
 - The SD Memory Card is not in a usable condition.
 - The SD Memory Card is write protected.
 - There is insufficient space available on the SD Memory Card.
 - The value of *FileName* is not a valid file name.
 - The maximum number of files or directories is exceeded.
 - A file with the name *FileName* already exists and the file is being accessed.
 - A file with the name *FileName* already exists and the value of *OverWrite* is FALSE.
 - A file with the name *FileName* already exists and the file is write protected.
 - If more than four SD Memory Card instructions that do not have a *FileID* variable (i.e., *FileWriteVar*, *FileReadVar*, *FileCopy*, *DirCreate*, *FileRemove*, *DirRemove*, and *FileRename*) are executed at the same time.
 - The value of *FileName* exceeds the maximum number of bytes allowed in a file name.
 - An error that prevents access occurs during SD Memory Card access.

Sample Programming

This sample writes all of array variable *Var1[]* to the file 'File1.dat.'

LD

Internal Variables	Variable	Data type	Initial value	Comment
	OperatingEnd	BOOL	FALSE	Processing completed.
	Trigger	BOOL	FALSE	Execution condition
	Operating	BOOL	FALSE	Processing
	Var1	ARRAY[0..999] OF INT	[1000(0)]	Write data
	RS_instance	RS		
	FileWriteVar_instance	FileWriteVar		

External Variables	Variable	Data type	Comment
	_Card1Ready	BOOL	SD Memory Card Ready Flag

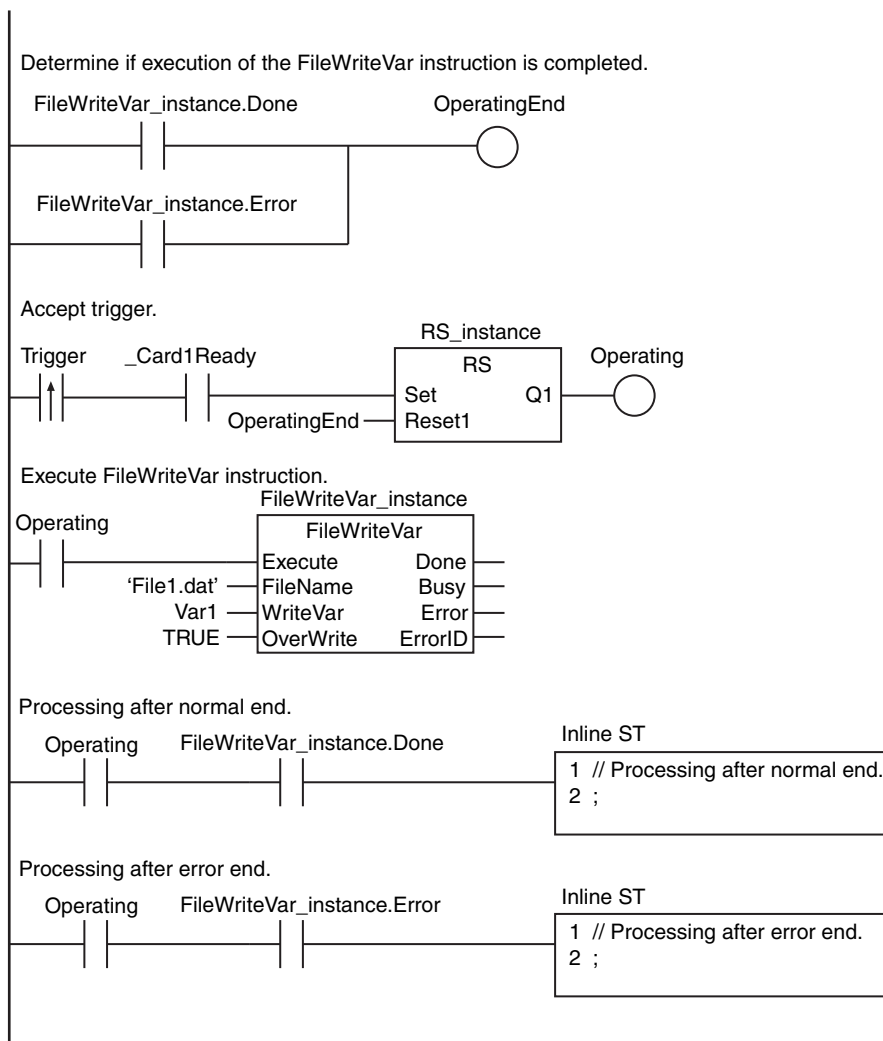

ST

Internal Variables	Variable	Data type	Initial value	Comment
	Trigger	BOOL	FALSE	Execution condition
	LastTrigger	BOOL	FALSE	Value of <i>Trigger</i> from previous task period
	OperatingStart	BOOL	FALSE	Processing started.
	Operating	BOOL	FALSE	Processing
	Var1	ARRAY[0..999] OF INT	[1000(0)]	Variable
	FileWriteVar_instance	FileWriteVar		

External Variables	Variable	Data type	Comment
	_Card1Ready	BOOL	SD Memory Card Ready Flag

```
// Detect when Trigger changes to TRUE.
IF ( (Trigger=TRUE) AND (LastTrigger=FALSE) AND (_Card1Ready=TRUE) ) THEN
    OperatingStart:=TRUE;
    Operating      :=TRUE;
END_IF;
LastTrigger:=Trigger;

// Initialize FileWriteVar instruction.
IF (OperatingStart=TRUE) THEN
    FileWriteVar_instance(
        Execute      :=FALSE,
        WriteVar     :=Var1);
    OperatingStart :=FALSE;
END_IF;

// Execute FileWriteVar instruction.
IF (Operating=TRUE) THEN
    FileWriteVar_instance(
        Execute :=TRUE,
        FileName :='File1.dat', // File name
        WriteVar :=Var1,       // Variable
        OverWrite:=TRUE);     // Enable overwrite.

    IF (FileWriteVar_instance.Done=TRUE) THEN
        // Processing after normal end.
        Operating:=FALSE;
    END_IF;

    IF (FileWriteVar_instance.Error=TRUE) THEN
        // Processing after error end.
        Operating:=FALSE;
    END_IF;
END_IF;
```

FileReadVar

The FileReadVar instruction reads the contents of the specified file on the SD Memory Card as binary data and writes it to a variable.

Instruction	Name	FB/FUN	Graphic expression	ST expression
FileReadVar	Read Variable from File	FB	<pre> FileReadVar_instance ┌───────────┬───────────┐ │ FileReadVar │ │ ├───────────┴───────────┤ │ Execute Done │ ├───────────┬───────────┤ │ FileName Busy │ ├───────────┬───────────┤ │ ReadVar │ │ ├───────────┴───────────┤ │ Error │ │ ├───────────┬───────────┤ │ ErrorID │ │ └───────────┴───────────┘ </pre>	FileReadVar_instance(Execute, FileName, ReadVar, Done, Busy, Error, ErrorID);

Variables

Name	Meaning	I/O	Description	Valid range	Unit	Default
FileName	File name	Input	Name of file to read	66 bytes max. (65 single-byte alphanumeric characters plus the final NULL character)	---	"
ReadVar	Variable to write	In-out	Variable to which to write the value that was read	Depends on data type.	---	---

	Boolean	Bit strings				Integers							Real numbers		Times, durations, dates, and text strings					
	BOOL	BYTE	WORD	DWORD	LWORD	USINT	UINT	UDINT	ULINT	SINT	INT	DINT	LINT	REAL	LREAL	TIME	DATE	TOD	DT	STRING
FileName																				OK
ReadVar	OK	OK	OK	OK	OK	OK	OK	OK	OK	OK	OK	OK	OK	OK	OK	OK	OK	OK	OK	OK

An enumeration, array, array element, structure, or structure member can also be specified.

Function

The FileReadVar instruction reads the contents of the file specified by *FileName* from the SD Memory Card as binary data. The contents that is read is assigned to variable to write *ReadVar*. You can specify an enumeration, array, array element, structure, or structure member for *ReadVar*.

The following figure shows a programming example. Here, the contents of the file called 'Temp/f_name.bin' is read and written to the array variable abc[]. Variable abc is an INT array variable with three elements.

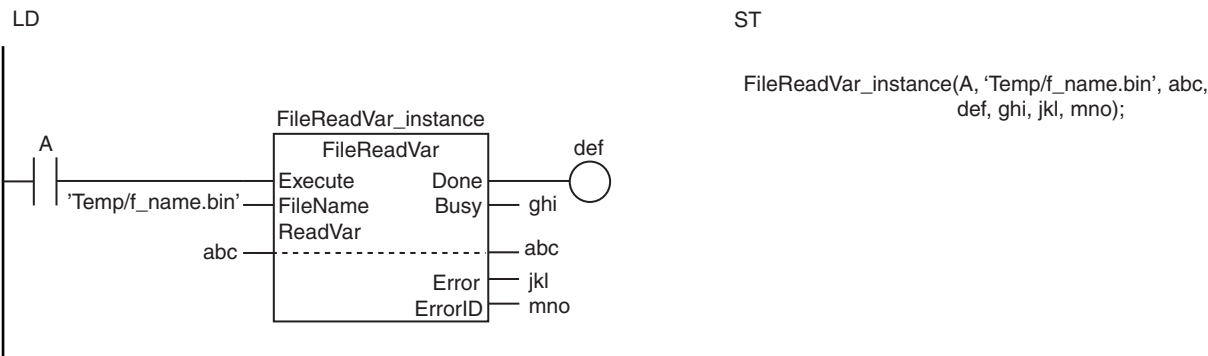

The FileReadVar instruction reads the contents of the file specified by *FileName* from the SD Memory Card as binary data and assigns it to variable *ReadVar*.

File *FileName* = 'Temp/f_name.bin'

ReadVar[0]=abc[0]
ReadVar[1]=abc[1]
ReadVar[2]=abc[2]

INT#1234
INT#2345
INT#3456

Read.

INT#1234
INT#2345
INT#3456

Related System-defined Variables

Name	Meaning	Data type	Description
_Card1Ready	SD Memory Card Ready Flag	BOOL	This flag indicates if the SD Memory Card can be accessed by instructions and communications commands.*1 TRUE: Can be used. FALSE: Cannot be used.
_Card1Protect*2	SD Memory Card Write Protected Flag	BOOL	This flag indicates if the SD Memory Card is write protected when it is inserted and ready to use. TRUE: Write protected. FALSE: Not write protected.
_Card1Err*2	SD Memory Card Error Flag	BOOL	This flag indicates if an unspecified SD Memory Card (e.g., an SDHC card) is mounted or if the format is incorrect (i.e., not FAT16 or corrupted). TRUE: Error. FALSE: No error.
_Card1Access*2	SD Memory Card Access Flag	BOOL	This flag indicates if the SD Memory Card is currently being accessed. TRUE: Being accessed. FALSE: Not being accessed.
_Card1PowerFail	SD Memory Card Power Interruption Flag	BOOL	This flag indicates if an error occurred in completing processing when power was interrupted during access*3. This flag is not cleared automatically. TRUE: Error. FALSE: No error.

*1 For the NJ/NX-series, it is a precondition that the SD Memory Card is physically inserted and mounted normally. For an NY-series Controller, it is a precondition that the shared folder is detected by the Controller.

*2 These variables are not used for the NY-series Controller. They are fixed to FALSE.

*3 For the NJ/NX-series, this indicates an access to the SD Memory Card. For an NY-series Controller, this indicates an access to the shared folder.

Additional Information

The root directory of the file name is the top level of the SD Memory Card.

Precautions for Correct Use

- Execution of this instruction is continued until processing is completed even if the value of *Execute* changes to FALSE or the execution time exceeds the task period. The value of *Done* changes to TRUE when processing is completed. Use this to confirm normal completion of processing.
- Refer to *Using this Section* on page 2-3 for a timing chart for *Execute*, *Done*, *Busy*, and *Error*.
- If the specified file is larger than the size of *ReadVar*, an error does not occur and only data that corresponds to the size of *ReadVar* is read.
- If the specified file is smaller than the size of *ReadVar*, an error does not occur and only data that corresponds to the size of the specified file is read. The remaining area in *ReadVar* will retain the values from before execution of this instruction.
- Data is read in byte increments. The lower bytes are read before the upper bytes (little endian).
- If *ReadVar* is a structure, adjustment areas between members may be inserted depending on the composition.
- Do not simultaneously access the same file. Perform exclusive control of SD Memory Card instructions in the user program.
- You cannot specify a device variable for *ReadVar*. If you specify a device variable, the value that was read is not assigned to *ReadVar*.
- An error occurs in the following cases. *Error* will change to TRUE.
 - The SD Memory Card is not in a usable condition.
 - The file specified by *FileName* does not exist.
 - The value of *FileName* is not a valid file name.
 - The file specified by *FileName* is being accessed.
 - If more than four SD Memory Card instructions that do not have a *FileID* variable (i.e., *FileWriteVar*, *FileReadVar*, *FileCopy*, *DirCreate*, *FileRemove*, *DirRemove*, and *FileRename*) are executed at the same time.
 - The value of *FileName* exceeds the maximum number of bytes allowed in a file name.
 - An error that prevents access occurs during SD Memory Card access.

Sample Programming

This sample reads the contents of the file 'File1.dat' and stores it in array variable *Var1*.

LD

Internal Variables	Variable	Data type	Initial value	Comment
	OperatingEnd	BOOL	FALSE	Processing completed.
	Trigger	BOOL	FALSE	Execution condition
	Operating	BOOL	FALSE	Processing
	Var1	ARRAY[0..999] OF INT	[1000(0)]	Read data
	RS_instance	RS		
	FileReadVar_instance	FileReadVar		

External Variables	Variable	Data type	Comment
	_Card1Ready	BOOL	SD Memory Card Ready Flag

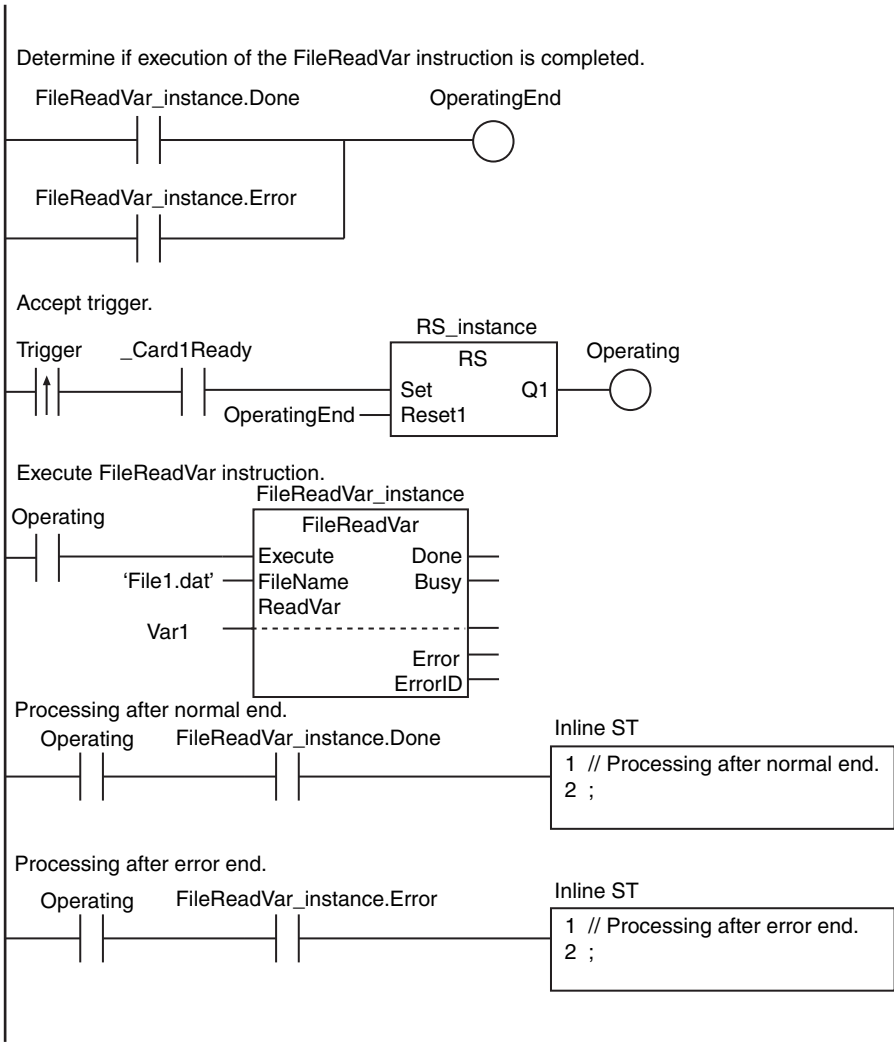

ST

Internal Variables	Variable	Data type	Initial value	Comment
	Trigger	BOOL	FALSE	Execution condition
	LastTrigger	BOOL	FALSE	Value of <i>Trigger</i> from previous task period
	OperatingStart	BOOL	FALSE	Processing started.
	Operating	BOOL	FALSE	Processing
	Var1	ARRAY[0..999] OF INT	[1000(0)]	Variable to read
	FileReadVar_instance	FileReadVar		

External Variables	Variable	Data type	Comment
	_Card1Ready	BOOL	SD Memory Card Ready Flag

```

// Detect when Trigger changes to TRUE.
IF ( (Trigger=TRUE) AND (LastTrigger=FALSE) AND (_Card1Ready=TRUE) ) THEN
    OperatingStart:=TRUE;
    Operating      :=TRUE;
END_IF;
LastTrigger:=Trigger;

// Initialize FileReadVar instruction.
IF (OperatingStart=TRUE) THEN
    FileReadVar_instance(
        Execute :=FALSE,
        ReadVar :=Var1);
    OperatingStart:=FALSE;
END_IF;

// Execute FileReadVar instruction.
IF (Operating=TRUE) THEN
    FileReadVar_instance(
        Execute :=TRUE,
        FileName :='File1.dat', // File name
        ReadVar :=Var1);      // Variable to read

    IF (FileReadVar_instance.Done=TRUE) THEN
        // Processing after normal end.
        Operating:=FALSE;
    END_IF;

    IF (FileReadVar_instance.Error=TRUE) THEN
        // Processing after error end.
        Operating:=FALSE;
    END_IF;
END_IF;

```

FileOpen

The FileOpen instruction opens the specified file in the SD Memory Card.

Instruction	Name	FB/FUN	Graphic expression	ST expression
FileOpen	Open File	FB		FileOpen_instance(Execute, FileName, Mode, Done, Busy, Error, ErrorID, FileID);

Variables

Name	Meaning	I/O	Description	Valid range	Unit	Default
FileName	File name	Input	Name of file to open	66 bytes max. (65 single-byte alphanumeric characters plus the final NULL character)	---	"
Mode	Open mode		Mode in which to open file	*		_READ_EXIST
FileID	File ID	Output	ID of file that was opened	Depends on data type.	---	---

* _READ_EXIST, _RDWR_EXIST, _WRITE_CREATE, _RDWR_CREATE, _WRITE_APPEND and _RDWR_APPEND

	Boolean	Bit strings				Integers							Real numbers		Times, durations, dates, and text strings					
	BOOL	BYTE	WORD	DWORD	LWORD	USINT	UINT	UDINT	ULINT	SINT	INT	DINT	LINT	REAL	LREAL	TIME	DATE	TOD	DT	STRING
FileName																				OK
Mode	Refer to <i>Function</i> for the enumerators for the enumerated type <code>_eFOPEN_MODE</code> .																			
FileID				OK																

Function

The FileOpen instruction opens the file specified by *FileName* in the SD Memory Card in the mode specified by *Mode*. The result is output to file ID *FileID*. *FileID* is used to specify the file in other instructions, such as FileRead and FileWrite.

The data type of *Mode* is enumerated type `_eFOPEN_MODE`. The meanings of the enumerators are as follows:

Enumerator	Meaning
_READ_EXIST	Use this value to open a text file to read it. The file is read from the beginning.
_RDWR_EXIST	Use this value to open a file to read and write it. The file is read and written from the beginning.
_WRITE_CREATE	Use this value to open a file to write it. If the file already exists, the contents is discarded and the file size is set to 0. If the file does not exist, a new file is created. The file is written from the beginning. However, if the file already exists and it is write-protected, an error occurs and the file is not opened.

Enumerator	Meaning
_RDWR_CREATE	Use this value to open a file to read and write it. If the file already exists, the contents is discarded and the file size is set to 0. If the file does not exist, a new file is created. The file is read and written from the beginning.
_WRITE_APPEND	Use this value to open a file to append data to it. If the file does not exist, a new file is created. The data is appended to the end of the file. However, if the file already exists and it is write-protected, an error occurs and the file is not opened.
_RDWR_APPEND	Use this value to open a file to read and append data to it. If the file does not exist, a new file is created. The file is read from the beginning. The data is appended to the end of the file.

The following figure shows a programming example. The file named 'Temp/f_name.bin' is opened to append data to it. The file ID is assigned to variable mno.

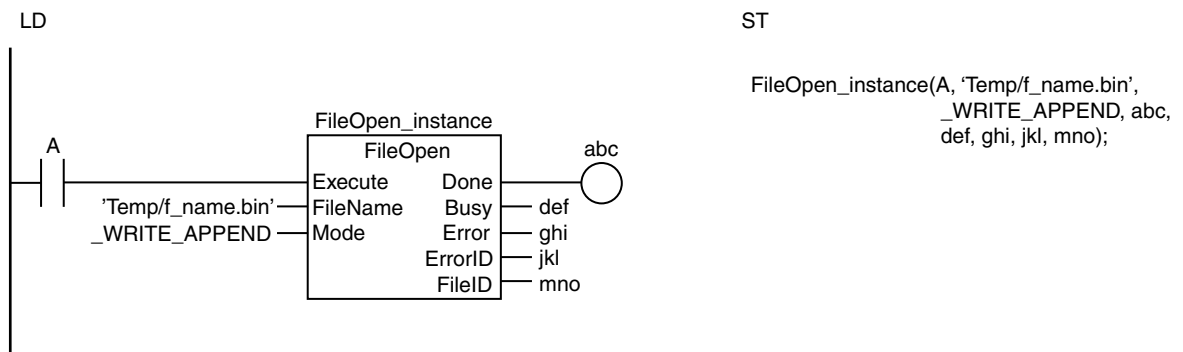

```

    ST
    FileOpen_instance(A, 'Temp/f_name.bin',
    _WRITE_APPEND, abc,
    def, ghi, jkl, mno);
  
```

The FileOpen instruction opens the file specified by *FileName* from the SD Memory Card to append data to it.
The file ID is assigned to variable *FileID*.

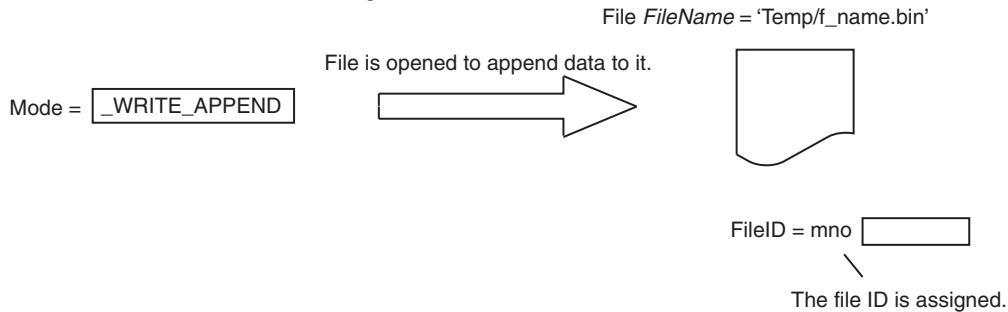

Related System-defined Variables

Name	Meaning	Data type	Description
_Card1Ready	SD Memory Card Ready Flag	BOOL	This flag indicates if the SD Memory Card can be accessed by instructions and communications commands.*1 TRUE: Can be used. FALSE: Cannot be used.
_Card1Protect*2	SD Memory Card Write Protected Flag	BOOL	This flag indicates if the SD Memory Card is write protected when it is inserted and ready to use. TRUE: Write protected. FALSE: Not write protected.
_Card1Err*2	SD Memory Card Error Flag	BOOL	This flag indicates if an unspecified SD Memory Card (e.g., an SDHC card) is mounted or if the format is incorrect (i.e., not FAT16 or corrupted). TRUE: Error. FALSE: No error.
_Card1Access*2	SD Memory Card Access Flag	BOOL	This flag indicates if the SD Memory Card is currently being accessed. TRUE: Being accessed. FALSE: Not being accessed.
_Card1PowerFail	SD Memory Card Power Interruption Flag	BOOL	This flag indicates if an error occurred in completing processing when power was interrupted during access*3. This flag is not cleared automatically. TRUE: Error. FALSE: No error.

*1 For the NJ/NX-series, it is a precondition that the SD Memory Card is physically inserted and mounted normally. For an NY-series Controller, it is a precondition that the shared folder is detected by the Controller.

*2 These variables are not used for the NY-series Controller. They are fixed to FALSE.

*3 For the NJ/NX-series, this indicates an access to the SD Memory Card. For an NY-series Controller, this indicates an access to the shared folder.

Additional Information

The root directory of the file name is the top level of the SD Memory Card.

Precautions for Correct Use

- Execution of this instruction is continued until processing is completed even if the value of *Execute* changes to FALSE or the execution time exceeds the task period. The value of *Done* changes to TRUE when processing is completed. Use this to confirm normal completion of processing.
- Refer to *Using this Section* on page 2-3 for a timing chart for *Execute*, *Done*, *Busy*, and *Error*.
- This instruction must be executed before any of the following instructions: FileSeek, FileRead, FileWrite, FileGets, and FilePuts.
- You must use the FileClose instruction to close any file that is opened with this instruction after you finish using it.
- A value is stored in *FileID* when the instruction is completed. Specifically, it is stored when the value of *Done* changes from FALSE to TRUE.
- If a file is open when the operating mode of the CPU Unit is changed to PROGRAM mode or when a major fault level Controller error occurs, the file is closed by the system. Any read/write operations that are in progress are completed to the end.

- For an NJ/NX-series CPU Unit, if a file is open when the power supply is stopped with the SD Memory Card power supply switch, the file is not corrupted. However, use the FileClose instruction to close the file, since the file remains open.
- For an NJ/NX-series CPU Unit, if a file is open and the SD Memory Card is removed before the SD Memory Card power supply switch is pressed, the contents of the file will sometimes be corrupted. Always turn OFF the power supply before removing the SD Memory Card.
- For an NJ/NX-series CPU Unit, if a file is open and the SD Memory Card is removed before the SD Memory Card power supply switch is pressed, the file will remain open. Use the FileClose instruction to close the file.
- For an NJ/NX-series CPU Unit, if a file is open when the power supply is stopped or the SD Memory Card is removed, the file will remain open, but it will not be possible to read or write the file even if the SD Memory Card is inserted again. To read/write the file, close the file and then open it again.
- Do not simultaneously access the same file. Perform exclusive control of SD Memory Card instructions in the user program.
- An error occurs in the following cases. *Error* will change to TRUE.
 - The SD Memory Card is not in a usable condition.
 - The SD Memory Card is write protected.
 - The value of *Mode* is `_READ_EXIST` or `_RDWR_EXIST` and the file specified with *FileName* does not exist.
 - The value of *FileName* is not a valid file name.
 - The maximum number of files or directories is exceeded.
 - The file specified by *FileName* is being accessed.
 - The file specified by *FileName* is write protected.
 - An attempt was made to open more than five files at the same time.
 - The value of *FileName* exceeds the maximum number of bytes allowed in a file name.
 - An error that prevents access occurs during SD Memory Card access.
 - The value of *Mode* is outside of the valid range.
 - For CPU Unit version 1.10 or later, if you try to open a file that is already open, a File Already in Use error occurs and the file ID of the open file is stored in the *FileID* output variable. The *FileID* output variable does not change if any other error occurs. For CPU Unit version 1.09 or earlier, 0 is stored in the *FileID* output variable if an error occurs.

Sample Programming

Refer to the sample programming for the following instructions: FileRead (page 2-1359), FileWrite (page 2-1367), FileGets (page 2-1375), and FilePuts (page 2-1383).

FileClose

The FileClose instruction closes the specified file in the SD Memory Card.

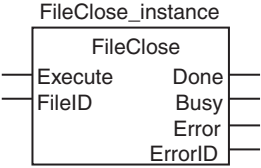
Instruction	Name	FB/FUN	Graphic expression	ST expression
FileClose	Close File	FB		FileClose_instance(Execute, FileID, Done, Busy, Error, ErrorID);

Variables

Name	Meaning	I/O	Description	Valid range	Unit	Default
FileID	File ID	Input	ID of file to close	Depends on data type.	---	0

	Boolean	Bit strings					Integers							Real numbers	Times, durations, dates, and text strings						
		BOOL	BYTE	WORD	DWORD	LWORD	USINT	UINT	UDINT	ULINT	SINT	INT	DINT		LINT	REAL	LREAL	TIME	DATE	TOD	DT
FileID				OK																	

Function

The FileClose instruction closes the file specified by *FileID* in the SD Memory Card.

The following figure shows a programming example. Here, the file whose file ID is the value of variable *abc* is closed.

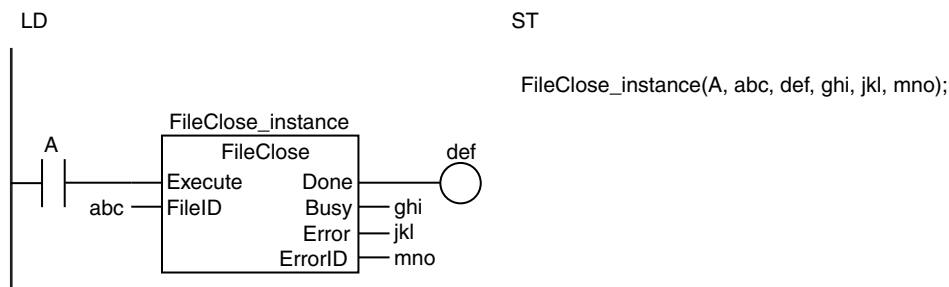

The FileClose instruction closes the file specified by *FileID* in the SD Memory Card.

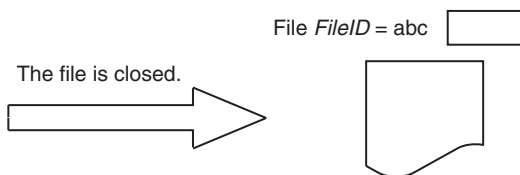

Related System-defined Variables

Name	Meaning	Data type	Description
_Card1Ready	SD Memory Card Ready Flag	BOOL	This flag indicates if the SD Memory Card can be accessed by instructions and communications commands.*1 TRUE: Can be used. FALSE: Cannot be used.
_Card1Protect*2	SD Memory Card Write Protected Flag	BOOL	This flag indicates if the SD Memory Card is write protected when it is inserted and ready to use. TRUE: Write protected. FALSE: Not write protected.
_Card1Err*2	SD Memory Card Error Flag	BOOL	This flag indicates if an unspecified SD Memory Card (e.g., an SDHC card) is mounted or if the format is incorrect (i.e., not FAT16 or corrupted). TRUE: Error. FALSE: No error.
_Card1Access*2	SD Memory Card Access Flag	BOOL	This flag indicates if the SD Memory Card is currently being accessed. TRUE: Being accessed. FALSE: Not being accessed.
_Card1PowerFail	SD Memory Card Power Interruption Flag	BOOL	This flag indicates if an error occurred in completing processing when power was interrupted during access*3. This flag is not cleared automatically. TRUE: Error. FALSE: No error.

*1 For the NJ/NX-series, it is a precondition that the SD Memory Card is physically inserted and mounted normally. For an NY-series Controller, it is a precondition that the shared folder is detected by the Controller.

*2 These variables are not used for the NY-series Controller. They are fixed to FALSE.

*3 For the NJ/NX-series, this indicates an access to the SD Memory Card. For an NY-series Controller, this indicates an access to the shared folder.

Additional Information

You must open files with the FileOpen instruction for the following instructions: FileSeek, FileRead, FileWrite, FileGets, and FilePuts.

Precautions for Correct Use

- Execution of this instruction is continued until processing is completed even if the value of *Execute* changes to FALSE or the execution time exceeds the task period. The value of *Done* changes to TRUE when processing is completed. Use this to confirm normal completion of processing.
- Refer to *Using this Section* on page 2-3 for a timing chart for *Execute*, *Done*, *Busy*, and *Error*.
- You must use the FileOpen instruction in advance to obtain the value for *FileID*.
- You must use this instruction to close any file that is opened with the FileOpen instruction after you finish using it.
- If a file is open when the operating mode of the CPU Unit is changed to PROGRAM mode or when a major fault level Controller error occurs, the file is closed by the system. Any read/write operations that are in progress are completed to the end.

- For an NJ/NX-series CPU Unit, if a file is open when the power supply is stopped with the SD Memory Card power supply switch, the file is not corrupted. However, use the FileClose instruction to close the file, since the file remains open.
- For an NJ/NX-series CPU Unit, if a file is open and the SD Memory Card is removed before the SD Memory Card power supply switch is pressed, the contents of the file will sometimes be corrupted. Always turn OFF the power supply before removing the SD Memory Card.
- For an NJ/NX-series CPU Unit, if a file is open and the SD Memory Card is removed before the SD Memory Card power supply switch is pressed, the file will remain open. Use the FileClose instruction to close the file.
- For an NJ/NX-series CPU Unit, if a file is open when the power supply is stopped or the SD Memory Card is removed, the file will remain open, but it will not be possible to read or write the file even if the SD Memory Card is inserted again. To read/write the file, close the file and then open it again.
- Do not simultaneously access the same file. Perform exclusive control of SD Memory Card instructions in the user program.
- An error occurs in the following cases. *Error* will change to TRUE.
 - The file specified by *FileID* does not exist.
 - The file specified by *FileID* is already closed.
 - The file specified by *FileID* is being accessed.
 - An error that prevents access occurs during SD Memory Card access.
 - The SD Memory Card is not in a usable condition.

Sample Programming

Refer to the sample programming for the following instructions: FileRead (page 2-1359), FileWrite (page 2-1367), FileGets (page 2-1375), and FilePuts (page 2-1383).

FileSeek

The FileSeek instruction sets a file position indicator in the specified file in the SD Memory Card.

Instruction	Name	FB/FUN	Graphic expression	ST expression
FileSeek	Seek File	FB	<pre> FileSeek_instance ┌─── FileSeek ───┐ │ Execute Done │ │ FileID Busy │ │ Offset Error │ │ Origin ErrorID │ └───┬───┬───┬───┘ </pre>	FileSeek_instance(Execute, FileID, Offset, Origin, Done, Busy, Error, ErrorID);

Variables

Name	Meaning	I/O	Description	Valid range	Unit	Default
FileID	File ID	Input	ID of file in which to set file position indicator	Depends on data type.	---	0
Offset	Offset		Offset from <i>Origin</i>		Bytes	
Origin	Reference position		Reference position for file position indicator	_SEEK_SET, _SEEK_CUR, or _SEEK_END	---	_SEEK_SET

	Boolean	Bit strings					Integers							Real numbers		Times, durations, dates, and text strings				
	BOOL	BYTE	WORD	DWORD	LWORD	USINT	UINT	UDINT	ULINT	SINT	INT	DINT	LINT	REAL	LREAL	TIME	DATE	TOD	DT	STRING
FileID				OK																
Offset											OK									
Origin	Refer to <i>Function</i> for the enumerators for the enumerated type <code>_eFSEEK_ORIGIN</code> .																			

Function

The FileSeek instruction sets a file position indicator in the file specified by file ID *FileID* in the SD Memory Card. A file position indicator is the position in a file at which to start reading or writing when an instruction such as the FileRead or FileWrite instruction is executed. For example, to read from the beginning of a file, set a file position indicator at the beginning of the file with the FileSeek instruction, and then execute the FileRead instruction. The file position indicator is set at offset *Offset* from reference position *Origin*.

The data type of *Origin* is enumerated type `_eFSEEK_ORIGIN`. The meanings of the enumerators are as follows:

Enumerator	Meaning
<code>_SEEK_SET</code>	Beginning of file
<code>_SEEK_CUR</code>	Location of current file position indicator
<code>_SEEK_END</code>	End of file

The following figure shows a programming example. A file position indicator is set at 100 bytes from the beginning of the file.

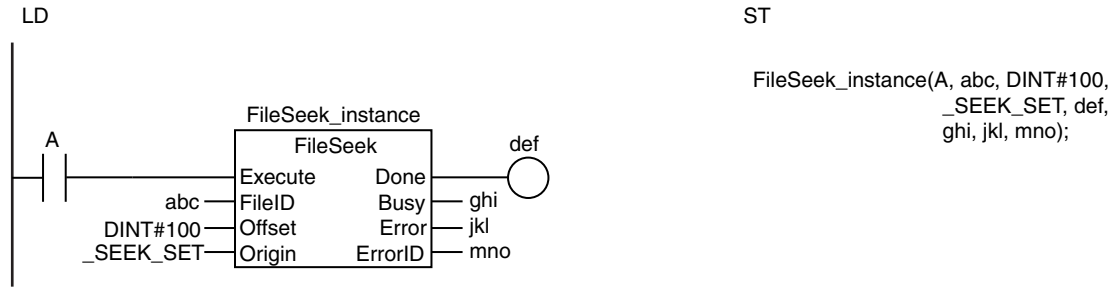

The FileSeek instruction sets a file position indicator in the file specified by *FileID* in the SD Memory Card. The file position indicator is at the position that is *Offset* from the beginning of the file.

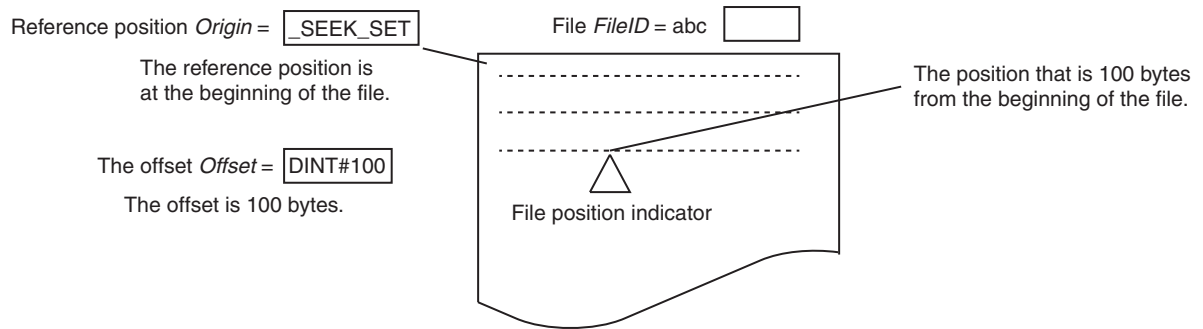

Related System-defined Variables

Name	Meaning	Data type	Description
_Card1Ready	SD Memory Card Ready Flag	BOOL	This flag indicates if the SD Memory Card can be accessed by instructions and communications commands.*1 TRUE: Can be used. FALSE: Cannot be used.
_Card1Protect*2	SD Memory Card Write Protected Flag	BOOL	This flag indicates if the SD Memory Card is write protected when it is inserted and ready to use. TRUE: Write protected. FALSE: Not write protected.
_Card1Err*2	SD Memory Card Error Flag	BOOL	This flag indicates if an unspecified SD Memory Card (e.g., an SDHC card) is mounted or if the format is incorrect (i.e., not FAT16 or corrupted). TRUE: Error. FALSE: No error.
_Card1Access*2	SD Memory Card Access Flag	BOOL	This flag indicates if the SD Memory Card is currently being accessed. TRUE: Being accessed. FALSE: Not being accessed.
_Card1PowerFail	SD Memory Card Power Interruption Flag	BOOL	This flag indicates if an error occurred in completing processing when power was interrupted during access*3. This flag is not cleared automatically. TRUE: Error. FALSE: No error.

*1 For the NJ/NX-series, it is a precondition that the SD Memory Card is physically inserted and mounted normally. For an NY-series Controller, it is a precondition that the shared folder is detected by the Controller.

*2 These variables are not used for the NY-series Controller. They are fixed to FALSE.

*3 For the NJ/NX-series, this indicates an access to the SD Memory Card. For an NY-series Controller, this indicates an access to the shared folder.

Precautions for Correct Use

- Execution of this instruction is continued until processing is completed even if the value of *Execute* changes to FALSE or the execution time exceeds the task period. The value of *Done* changes to TRUE when processing is completed. Use this to confirm normal completion of processing.
- Refer to *Using this Section* on page 2-3 for a timing chart for *Execute*, *Done*, *Busy*, and *Error*.
- You must use the FileOpen instruction to obtain the value for *FileID* before you execute this instruction.
- Do not simultaneously access the same file. Perform exclusive control of SD Memory Card instructions in the user program.
- An error occurs in the following cases. *Error* will change to TRUE.
 - The value of *Origin* is outside of the valid range.
 - The SD Memory Card is not in a usable condition.
 - The file specified by *FileID* does not exist.
 - The file specified by *FileID* is being accessed.
 - The position specified by *Origin* and *Offset* exceeds the file size.
 - An error that prevents access occurs during SD Memory Card access.

Sample Programming

Refer to the sample programming for the following instructions: FileRead (page 2-1359) and FileWrite (page 2-1367).

FileRead

The FileRead instruction reads the data from the specified file in the SD Memory Card.

Instruction	Name	FB/FUN	Graphic expression	ST expression
FileRead	Read File	FB	<p>The graphic expression shows a box labeled 'FileRead' with the following connections:</p> <ul style="list-style-type: none"> Input: Execute Input: FileID Input: ReadBuf Input: Size Output: Done Output: Busy Output: Error Output: ErrorID Output: ReadSize Output: EOF 	FileRead_instance(Execute, FileID, ReadBuf, Size, Done, Busy, Error, ErrorID, ReadSize, EOF);

Variables

Name	Meaning	I/O	Description	Valid range	Unit	Default
FileID	File ID	Input	ID of file to read	Depends on data type.	---	0
Size	Number of elements to read		Number of elements to read			1
ReadBuf[] (array)	Read buffer	In-out	Buffer in which to write data that was read	Depends on data type.	---	---
ReadSize	Number of read elements	Output	Number of elements that were actually read	Depends on data type.	---	---
EOF	End of file		Whether end of file was reached TRUE: Reached. FALSE: Not reached.			

	Boolean	Bit strings				Integers							Real numbers	Times, durations, dates, and text strings						
	BOOL	BYTE	WORD	DWORD	LWORD	USINT	UINT	UDINT	ULINT	SINT	INT	DINT	LINT	REAL	LREAL	TIME	DATE	TOD	DT	STRING
FileID				OK																
Size							OK													
ReadBuf[] (array)	OK	OK	OK	OK	OK	OK	OK	OK	OK	OK	OK	OK	OK	OK	OK	OK	OK	OK	OK	OK
	Arrays enumerations or structures can also be specified.																			
ReadSize							OK													
EOF	OK																			

Function

The FileRead instruction reads the data from position of the file position indicator in the file specified by file ID *FileID* in the SD Memory Card. It then stores the data in read buffer *ReadBuf[]*. The file position indicator is set at the desired location in advance with the FileSeek instruction. The amount of data that is read is the size of the data type of *ReadBuf[]* times *Size*. You can specify an array of enumerations or structures for *ReadBuf[]*. The actual number of elements that were read is stored in *ReadSize*. Normally, *Size* and *ReadSize* will have the same values. If the amount of data from the file position indicator to the end of the file is smaller than *Size*, an error will not occur and the data to the end of the file is stored in *ReadBuf[]*. If that occurs, the value of *ReadSize* will be smaller than the value of *Size*. If data is read to the end of the file, end of file *EOF* changes to TRUE. Otherwise, the value of *EOF* will be FALSE.

The following figure shows a programming example. If the read buffer *def[]* is a BYTE array, 100 bytes of data is read from the file.

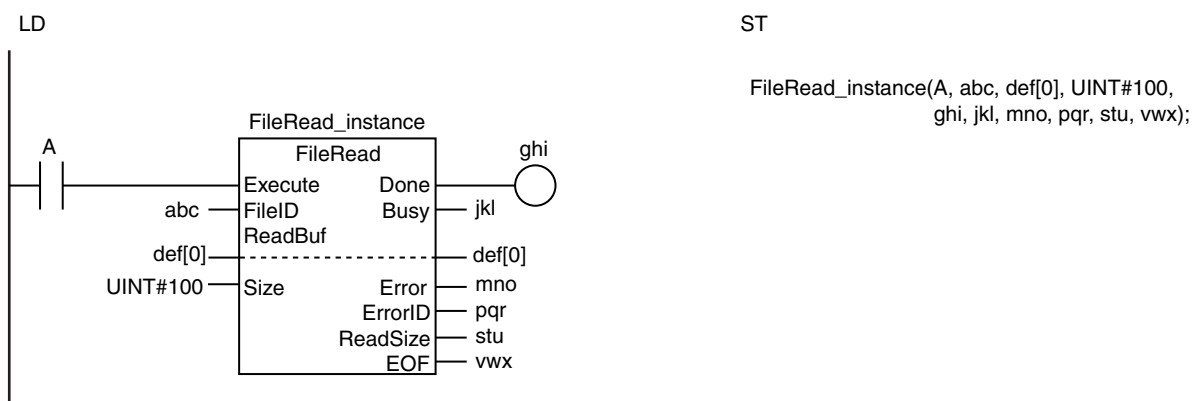

```

    ST
    FileRead_instance(A, abc, def[0], UINT#100,
    ghi, jkl, mno, pqr, stu, vwx);
  
```

The FileRead instruction reads *Size* elements from the position of the file position indicator in the file specified by *FileID* in the SD Memory Card. It then stores the data in read buffer *ReadBuf[]*. The actual data size that was read is output to *ReadSize*.

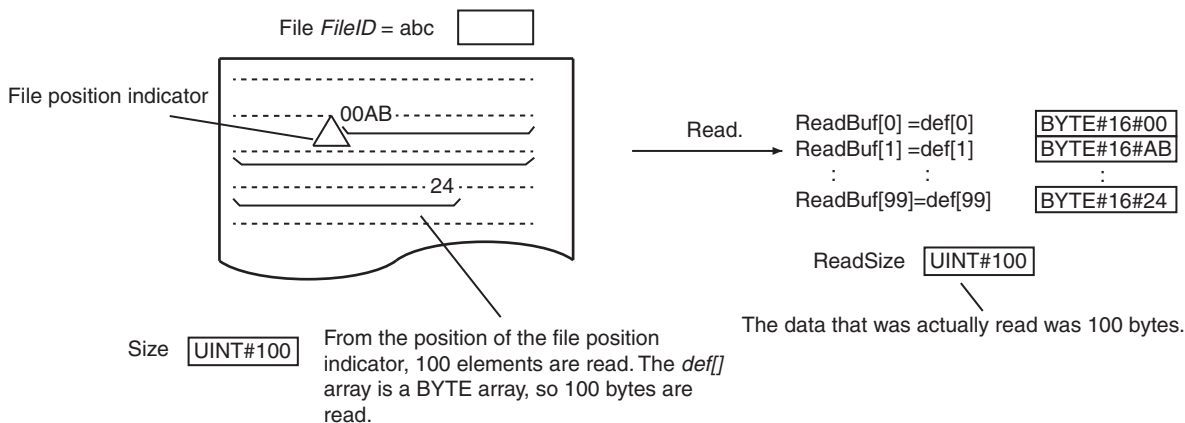

Related System-defined Variables

Name	Meaning	Data type	Description
_Card1Ready	SD Memory Card Ready Flag	BOOL	This flag indicates if the SD Memory Card can be accessed by instructions and communications commands.*1 TRUE: Can be used. FALSE: Cannot be used.

Name	Meaning	Data type	Description
_Card1Protect*2	SD Memory Card Write Protected Flag	BOOL	This flag indicates if the SD Memory Card is write protected when it is inserted and ready to use. TRUE: Write protected. FALSE: Not write protected.
_Card1Err*2	SD Memory Card Error Flag	BOOL	This flag indicates if an unspecified SD Memory Card (e.g., an SDHC card) is mounted or if the format is incorrect (i.e., not FAT16 or corrupted). TRUE: Error. FALSE: No error.
_Card1Access*2	SD Memory Card Access Flag	BOOL	This flag indicates if the SD Memory Card is currently being accessed. TRUE: Being accessed. FALSE: Not being accessed.
_Card1PowerFail	SD Memory Card Power Interruption Flag	BOOL	This flag indicates if an error occurred in completing processing when power was interrupted during access*3. This flag is not cleared automatically. TRUE: Error. FALSE: No error.

*1 For the NJ/NX-series, it is a precondition that the SD Memory Card is physically inserted and mounted normally. For an NY-series Controller, it is a precondition that the shared folder is detected by the Controller.

*2 These variables are not used for the NY-series Controller. They are fixed to FALSE.

*3 For the NJ/NX-series, this indicates an access to the SD Memory Card. For an NY-series Controller, this indicates an access to the shared folder.

Precautions for Correct Use

- Execution of this instruction is continued until processing is completed even if the value of *Execute* changes to FALSE or the execution time exceeds the task period. The value of *Done* changes to TRUE when processing is completed. Use this to confirm normal completion of processing.
- Refer to *Using this Section* on page 2-3 for a timing chart for *Execute*, *Done*, *Busy*, and *Error*.
- If the data is read to the end of the file and the size of the data is not evenly divisible by the size of the data type of *ReadBuf[]*, the data that is insufficient for the data size of *ReadBuf[]* is discarded. The file position indicator advances to the end of the file, and the value of *EOF* changes to TRUE.
- Elements beyond *Size* times *ReadBuf[]* (i.e., the elements not overwritten when data is read) will retain the values from before execution of this instruction.
- You must use the *FileOpen* instruction to obtain the value for *FileID* before you execute this instruction.
- Data is read in byte increments. The lower bytes are read before the upper bytes (little endian).
- A value is stored in *EOF* when the instruction is completed. Specifically, it is stored when the value of *Done* changes from FALSE to TRUE.
- If *ReadBuf[]* is an array of structures, adjustment areas between members may be inserted depending on the composition.
- If the operating mode of the CPU Unit is changed to PROGRAM mode or when a major fault level Controller error occurs during instruction execution, the file is closed by the system. Any read/write operations that are in progress are completed to the end.
- Do not simultaneously access the same file. Perform exclusive control of SD Memory Card instructions in the user program.
- You cannot specify a device variable for *ReadBuf[]*. If you specify a device variable, the data that was read is not assigned to *ReadBuf[]*.
- An error occurs in the following cases. *Error* will change to TRUE.

- The number of array elements in *ReadBuf[]* is smaller than the value of *Size*.
- The SD Memory Card is not in a usable condition.
- The file specified by *FileID* does not exist.
- The file specified by *FileID* is being accessed.
- The file specified by *FileID* was not opened in a reading mode.
- An error that prevents access occurs during SD Memory Card access.

Sample Programming

In this sample, four bytes of data are read from the second byte from beginning of the file named 'ABC.bin.' The data is written to BYTE array variable *InDat[]*. The processing procedure is as follows:

- 1** The FileOpen instruction is used to open the file 'ABC.bin.'
- 2** The FileSeek instruction is used to set a file position indicator at the second byte from the beginning of the file.
- 3** The FileRead instruction is used to read four bytes of data from the position of the file position indicator and store it in array variable *InDat[]*.
- 4** The FileClose instruction is used to close the file 'ABC.bin.'

LD

Internal Variables	Variable	Data type	Initial value	Comment
	OperatingEnd	BOOL	FALSE	Processing completed.
	Trigger	BOOL	FALSE	Execution condition
	Operating	BOOL	FALSE	Processing
	Fid	DWORD	16#0	File ID
	InDat	ARRAY[0..999] OF BYTE	[1000(16#0)]	Read data
	RS_instance	RS		
	FileOpen_instance	FileOpen		
	FileSeek_instance	FileSeek		
	FileRead_instance	FileRead		
	FileClose_instance	FileClose		

External Variables	Variable	Data type	Comment
	_Card1Ready	BOOL	SD Memory Card Ready Flag

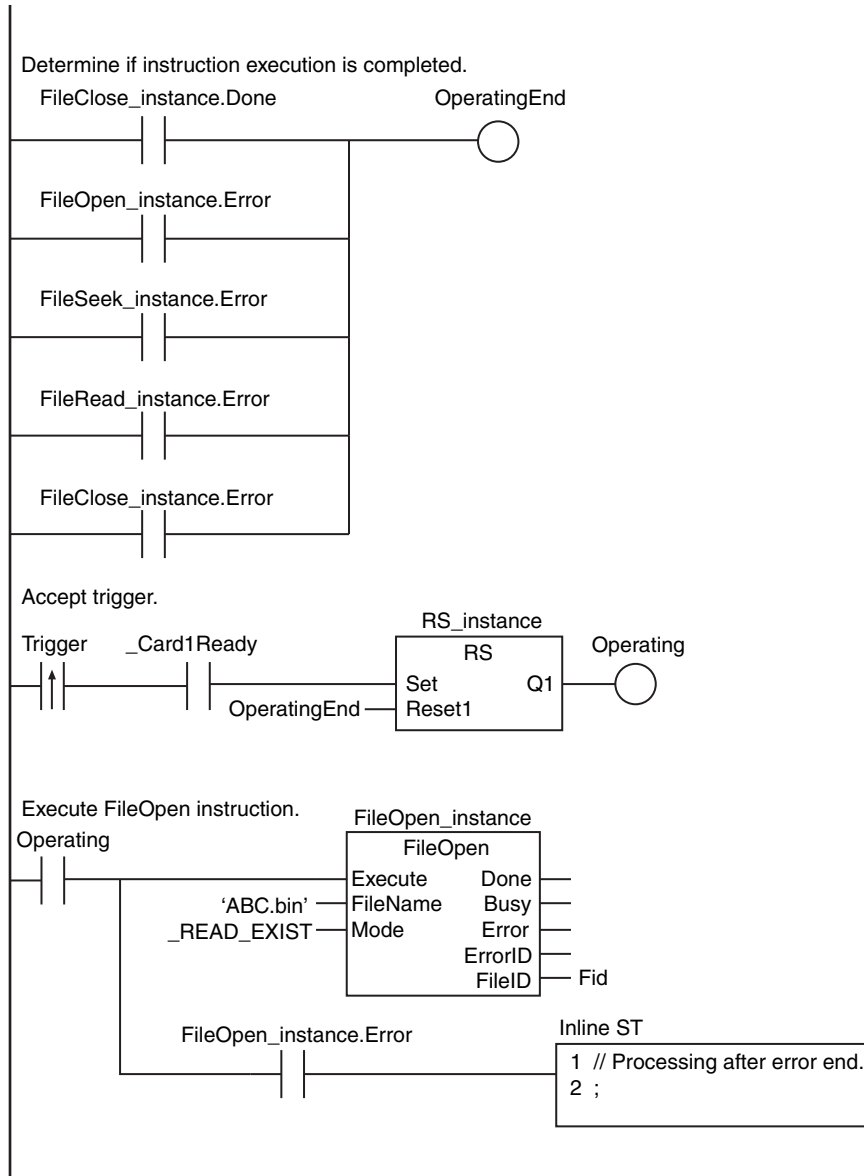

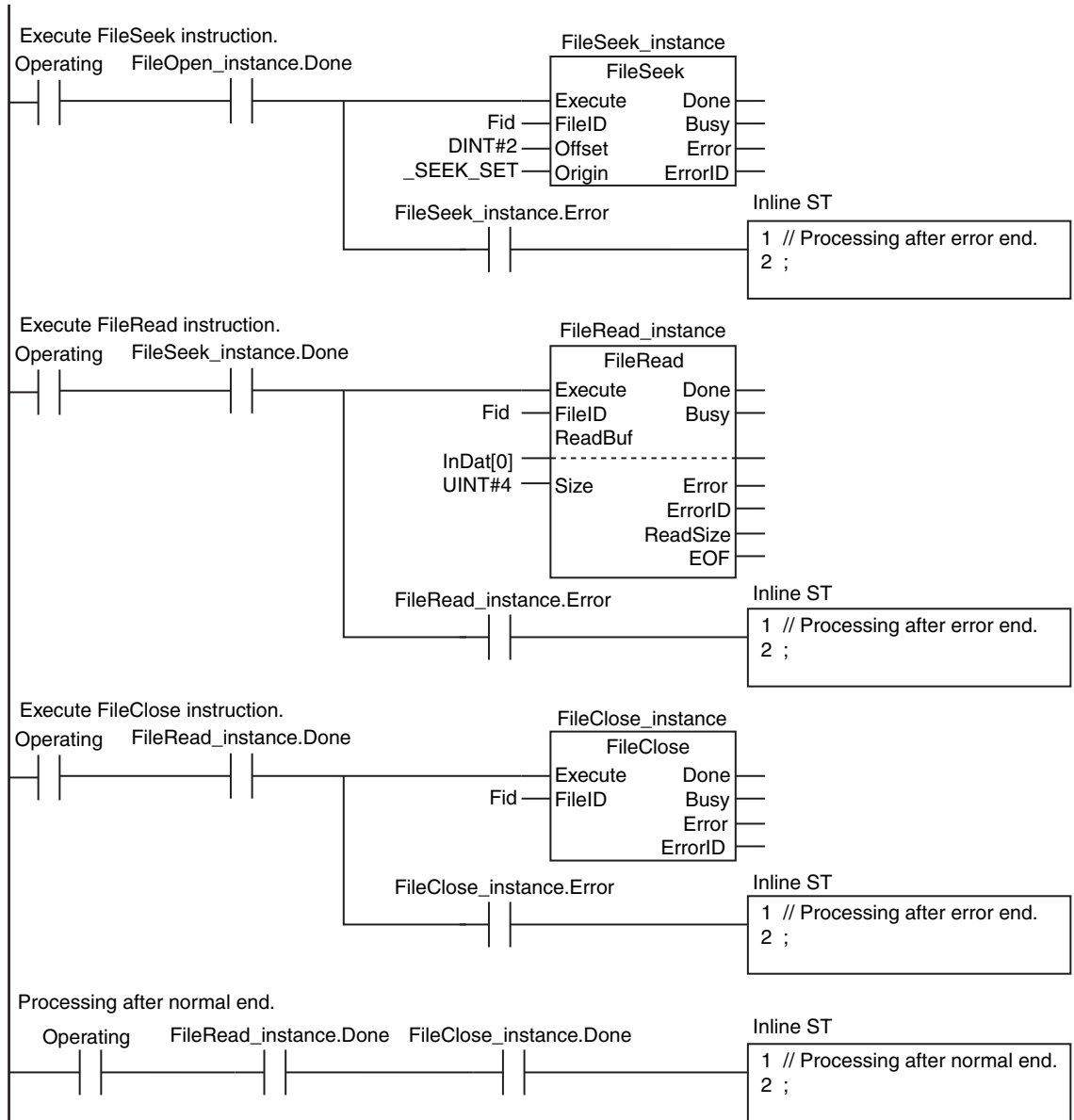

ST

Internal Variables	Variable	Data type	Initial value	Comment
	Trigger	BOOL	FALSE	Execution condition
	LastTrigger	BOOL	FALSE	Value of <i>Trigger</i> from previous task period
	OperatingStart	BOOL	FALSE	Processing started.
	Operating	BOOL	FALSE	Processing
	InDat	ARRAY[0..999] OF BYTE	[1000(16#0)]	Read data
	Stage	INT	0	Stage change
	Fid	DWORD	16#0	File ID
	FileOpen_instance	FileOpen		
	FileSeek_instance	FileSeek		
	FileRead_instance	FileRead		
	FileClose_instance	FileClose		

External Variables	Variable	Data type	Comment
	_Card1Ready	BOOL	SD Memory Card Ready Flag

```
// Start sequence when Trigger changes to TRUE.
IF ( (Trigger=TRUE) AND (LastTrigger=FALSE) AND (_Card1Ready=TRUE) ) THEN
    OperatingStart:=TRUE;
    Operating      :=TRUE;
END_IF;
LastTrigger:=Trigger;

// Initialize instance.
IF (OperatingStart=TRUE) THEN
    FileOpen_instance(Execute:=FALSE); // Initialize instance.
    FileSeek_instance(Execute:=FALSE); // Initialize instance.
    FileRead_instance(
        Execute:=FALSE, // Initialize instance.
        ReadBuf:=InDat[0]); // Dummy
    FileClose_instance(Execute:=FALSE); // Initialize instance.
    Stage      :=INT#1;
    OperatingStart:=FALSE;
END_IF;

// Execute instructions.
IF (Operating=TRUE) THEN
    CASE Stage OF
    1 : // Open file.
        FileOpen_instance(
            Execute:=TRUE,
            FileName:='ABC.bin', // File name
            Mode :=_READ_EXIST, // Read file.
            FileID =>Fid); // File ID

        IF (FileOpen_instance.Done=TRUE) THEN
            Stage:=INT#2; // Normal end
        END_IF;

        IF (FileOpen_instance.Error=TRUE) THEN
            Stage:=INT#99; // Error end
        END_IF;
    END_CASE;
END_IF;
```

```

2 :    // Seek file.
      FileSeek_instance(
          Execute:=TRUE,
          FileID :=Fid,      // File ID
          Offset  :=DINT#2,  // File position indicator goes to second byte from the beginning.
          Origin  :=_SEEK_SET);

      IF (FileSeek_instance.Done=TRUE) THEN
          Stage:=INT#3;    // Normal end
      END_IF;

      IF (FileSeek_instance.Error=TRUE) THEN
          Stage:=INT#99;   // Error end
      END_IF;

3 :    // Read file.
      FileRead_instance(
          Execute :=TRUE,
          FileID  :=Fid,    // File ID
          ReadBuf :=InDat[0], // Read buffer
          Size    :=UINT#4); // Number of elements to read: 4 bytes

      IF (FileRead_instance.Done=TRUE) THEN
          Stage:=INT#4;    // Normal end
      END_IF;

      IF (FileRead_instance.Error=TRUE) THEN
          Stage:=INT#99;   // Error end
      END_IF;

4 :    // Close file.
      FileClose_instance(
          Execute:=TRUE,
          FileID :=Fid);   // File ID

      IF (FileClose_instance.Done=TRUE) THEN
          Operating:=FALSE; // Normal end
      END_IF;

      IF (FileClose_instance.Error=TRUE) THEN
          Stage:=INT#99;   // Error end
      END_IF;

99 :
      Operating:=FALSE;    // Processing after error end.
      END_CASE;
END_IF;

```

FileWrite

The FileWrite instruction writes data to the specified file in the SD Memory Card.

Instruction	Name	FB/FUN	Graphic expression	ST expression
FileWrite	Write File	FB		FileWrite_instance(Execute, FileID, WriteBuf, Size, Done, Busy, Error, ErrorID, WriteSize);

Variables

Name	Meaning	I/O	Description	Valid range	Unit	Default
FileID	File ID	Input	ID of file to write	Depends on data type.	---	0
WriteBuf[] (array)	Write buffer		Write data			*
Size	Number of elements to write		Number of elements to write			1
WriteSize	Number of written elements	Output	Number of elements that were actually written	Depends on data type.	---	---

* If you omit the input parameter, the default value is not applied. A building error will occur.

	Boolean	Bit strings				Integers							Real numbers		Times, durations, dates, and text strings					
	BOOL	BYTE	WORD	DWORD	LWORD	USINT	UINT	UDINT	ULINT	SINT	INT	DINT	LINT	REAL	LREAL	TIME	DATE	TOD	DT	STRING
FileID				OK																
WriteBuf[] (array)	OK	OK	OK	OK	OK	OK	OK	OK	OK	OK	OK	OK	OK	OK	OK	OK	OK	OK	OK	OK
	Arrays of enumerations or structures can also be specified.																			
Size							OK													
WriteSize							OK													

Function

The FileWrite instruction writes data to the position of the file position indicator in the file specified by file ID *FileID* in the SD Memory Card. The file position indicator is set at the desired location in advance with the FileSeek instruction. The contents of the write buffer *WriteBuf[]* is written to the file. The amount of data that is written is the size of the data type of *WriteBuf[]* times *Size*. You can specify an array of enumerations or structures for *WriteBuf[]*. The data size that is actually written is output to *WriteSize*.

The following figure shows a programming example. If the write buffer *def[]* is BYTE data, 100 bytes of data is written to the file.

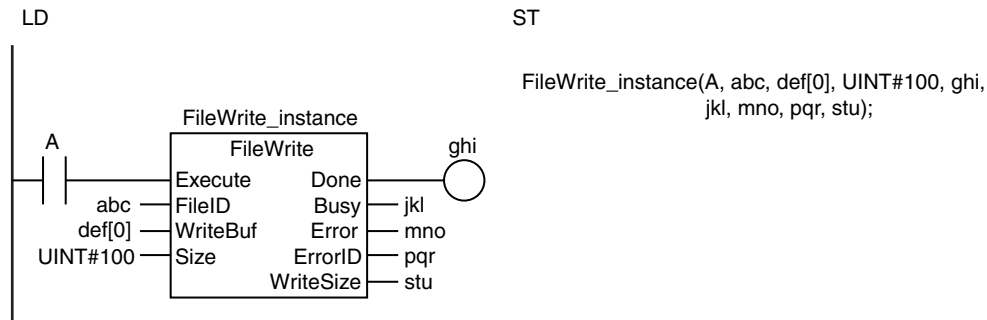

The FileWrite instruction writes the contents of the write buffer *WriteBuf[]* to the position of the file position indicator in the file specified by *FileID* in the SD Memory Card. Then the data size that is actually written is output to *WriteSize*.

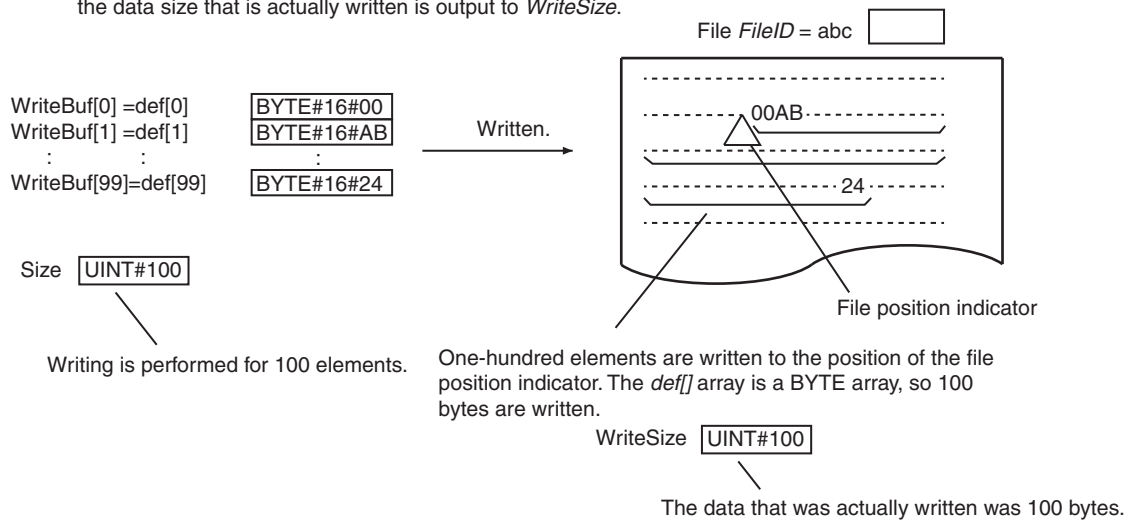

Related System-defined Variables

Name	Meaning	Data type	Description
_Card1Ready	SD Memory Card Ready Flag	BOOL	This flag indicates if the SD Memory Card can be accessed by instructions and communications commands.*1 TRUE: Can be used. FALSE: Cannot be used.
_Card1Protect*2	SD Memory Card Write Protected Flag	BOOL	This flag indicates if the SD Memory Card is write protected when it is inserted and ready to use. TRUE: Write protected. FALSE: Not write protected.

Name	Meaning	Data type	Description
_Card1Err*2	SD Memory Card Error Flag	BOOL	This flag indicates if an unspecified SD Memory Card (e.g., an SDHC card) is mounted or if the format is incorrect (i.e., not FAT16 or corrupted). TRUE: Error. FALSE: No error.
_Card1Access*2	SD Memory Card Access Flag	BOOL	This flag indicates if the SD Memory Card is currently being accessed. TRUE: Being accessed. FALSE: Not being accessed.
_Card1PowerFail	SD Memory Card Power Interruption Flag	BOOL	This flag indicates if an error occurred in completing processing when power was interrupted during access*3. This flag is not cleared automatically. TRUE: Error. FALSE: No error.

*1 For the NJ/NX-series, it is a precondition that the SD Memory Card is physically inserted and mounted normally. For an NY-series Controller, it is a precondition that the shared folder is detected by the Controller.

*2 These variables are not used for the NY-series Controller. They are fixed to FALSE.

*3 For the NJ/NX-series, this indicates an access to the SD Memory Card. For an NY-series Controller, this indicates an access to the shared folder.

Precautions for Correct Use

- Execution of this instruction is continued until processing is completed even if the value of *Execute* changes to FALSE or the execution time exceeds the task period. The value of *Done* changes to TRUE when processing is completed. Use this to confirm normal completion of processing.
- Refer to *Using this Section* on page 2-3 for a timing chart for *Execute*, *Done*, *Busy*, and *Error*.
- You must use the FileOpen instruction to obtain the value for *FileID* before you execute this instruction.
- Data is written in byte increments. The lower bytes are written before the upper bytes (little endian).
- If *WriteBuf[]* is an array of structures, adjustment areas between members may be inserted depending on the composition.
- If the operating mode of the CPU Unit is changed to PROGRAM mode or when a major fault level Controller error occurs during instruction execution, the file is closed by the system. Any read/write operations that are in progress are completed to the end.
- Do not simultaneously access the same file. Perform exclusive control of SD Memory Card instructions in the user program.
- An error occurs in the following cases. *Error* will change to TRUE.
 - The number of array elements in *WriteBuf[]* is smaller than the value of *Size*.
 - The SD Memory Card is not in a usable condition.
 - The SD Memory Card is write protected.
 - There is insufficient space available on the SD Memory Card.
 - The file specified by *FileID* does not exist.
 - The file specified by *FileID* is being accessed.
 - The file specified by *FileID* was not opened in a writing mode.
 - An error that prevents access occurs during SD Memory Card access.

Sample Programming

Here, four bytes of data are written from the second byte from the beginning of the file 'ABC.bin.' The contents of the BYTE array variable *OutDat[]* is written to the file. The processing procedure is as follows:

- 1** The FileOpen instruction is used to open the file 'ABC.bin.'
- 2** The FileSeek instruction is used to set a file position indicator at the second byte from the beginning of the file.
- 3** The FileWrite instruction is used to write four bytes from array variable *OutDat[]* to the position of the file position indicator.
- 4** The FileClose instruction is used to close the file 'ABC.bin.'

LD

Internal Variables	Variable	Data type	Initial value	Comment
	OperatingEnd	BOOL	FALSE	Processing completed.
	Trigger	BOOL	FALSE	Execution condition
	Operating	BOOL	FALSE	Processing
	Fid	DWORD	16#0	File ID
	OutDat	ARRAY[0..999] OF BYTE	[1000(16#0)]	Write data
	RS_instance	RS		
	FileOpen_instance	FileOpen		
	FileSeek_instance	FileSeek		
	FileWrite_instance	FileWrite		
	FileClose_instance	FileClose		

External Variables	Variable	Data type	Comment
	_Card1Ready	BOOL	SD Memory Card Ready Flag

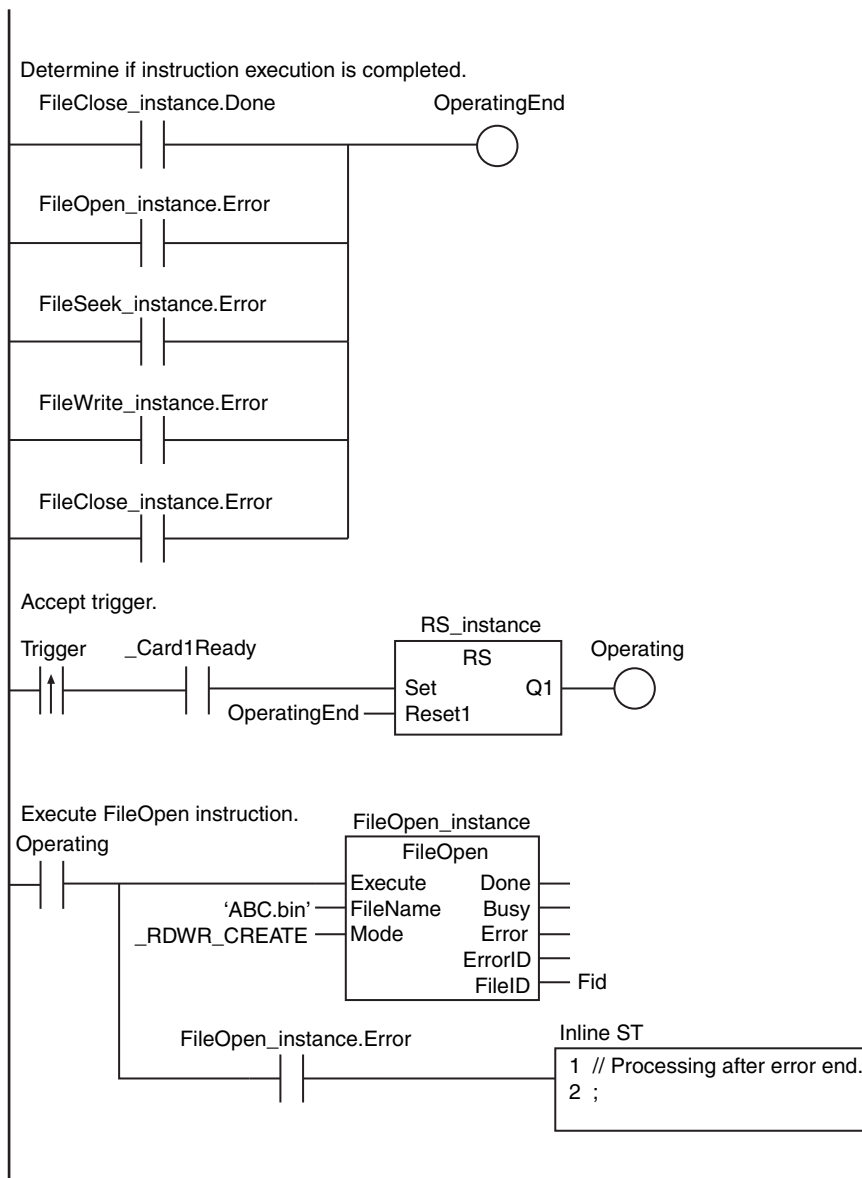

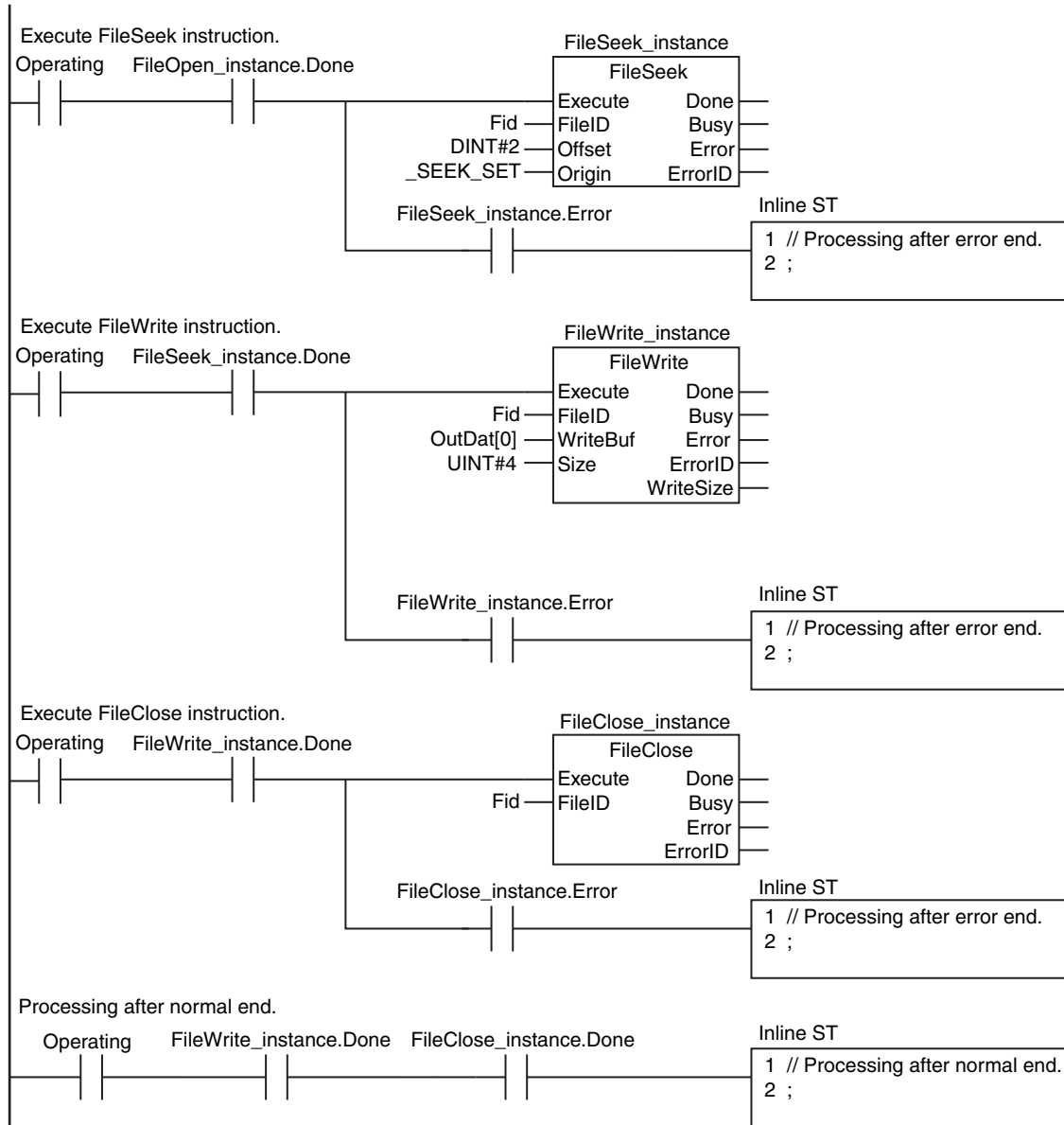

ST

Internal Variables	Variable	Data type	Initial value	Comment
	Trigger	BOOL	FALSE	Execution condition
	LastTrigger	BOOL	FALSE	Value of <i>Trigger</i> from previous task period
	OperatingStart	BOOL	FALSE	Processing started.
	Operating	BOOL	FALSE	Processing
	OutDat	ARRAY[0..999] OF BYTE	[1000(16#0)]	Write data
	Stage	INT	0	Stage change
	Fid	DWORD	16#0	File ID
	FileOpen_instance	FileOpen		
	FileSeek_instance	FileSeek		
	FileWrite_instance	FileWrite		
	FileClose_instance	FileClose		

External Variables	Variable	Data type	Comment
	_Card1Ready	BOOL	SD Memory Card Ready Flag

```
// Start sequence when Trigger changes to TRUE.
IF ( (Trigger=TRUE) AND (LastTrigger=FALSE) AND (_Card1Ready=TRUE) ) THEN
    OperatingStart:=TRUE;
    Operating      :=TRUE;
END_IF;
LastTrigger:=Trigger;

// Initialize instance.
IF (OperatingStart=TRUE) THEN
    FileOpen_instance(Execute:=FALSE);
    FileSeek_instance(Execute:=FALSE);
    FileWrite_instance(
        Execute      :=FALSE,
        WriteBuf     :=OutDat[0]);
    FileClose_instance(Execute:=FALSE);
    Stage           :=INT#1;
    OperatingStart:=FALSE;
END_IF;

// Execute instructions.
IF (Operating=TRUE) THEN
    CASE Stage OF
    1 : // Open file.
        FileOpen_instance(
            Execute :=TRUE,
            FileName:='ABC.bin', // File name
            Mode     :=_RDWR_CREATE, // Read file and write.
            FileID   =>Fid); // File ID

        IF (FileOpen_instance.Done=TRUE) THEN
            Stage:=INT#2; // Normal end
        END_IF;

        IF (FileOpen_instance.Error=TRUE) THEN
            Stage:=INT#99; // Error end
        END_IF;
    END_CASE;
END_IF;
```

```

2 :    // Seek file.
      FileSeek_instance(
          Execute :=TRUE,
          FileID  :=Fid,    // File ID
          Offset  :=DINT#2, // File position indicator goes to second byte from the beginning.
          Origin  :=_SEEK_SET);

      IF (FileSeek_instance.Done=TRUE) THEN
          Stage:=INT#3;    // Normal end
      END_IF;

      IF (FileSeek_instance.Error=TRUE) THEN
          Stage:=INT#99;  // Error end
      END_IF;

3 :    // Write file.
      FileWrite_instance(
          Execute :=TRUE,
          FileID  :=Fid,    // File ID
          WriteBuf:=OutDat[0], // Write buffer
          Size    :=UINT#4); // Number of elements to write: 4 bytes

      IF (FileWrite_instance.Done=TRUE) THEN
          Stage:=INT#4;    // Normal end
      END_IF;

      IF (FileWrite_instance.Error=TRUE) THEN
          Stage:=INT#99;  // Error end
      END_IF;

4 :    // Close file.
      FileClose_instance(
          Execute:=TRUE,
          FileID :=Fid);    // File ID

      IF (FileClose_instance.Done=TRUE) THEN
          Operating:=FALSE; // Normal end
      END_IF;

      IF (FileClose_instance.Error=TRUE) THEN
          Stage:=INT#99;    // Error end
      END_IF;

99 :
      Operating:=FALSE;    // Processing after error end.
      END_CASE;
END_IF;

```

FileGets

The FileGets instruction reads a text string of one line from the specified file in the SD Memory Card.

Instruction	Name	FB/FUN	Graphic expression	ST expression
FileGets	Get Text String	FB		FileGets_instance(Execute, FileID, TrimLF, Done, Busy, Error, ErrorID, Out, EOF);

Variables

Name	Meaning	I/O	Description	Valid range	Unit	Default
FileID	File ID	Input	ID of file to read	Depends on data type.	---	0
TrimLF	Line feed designation		Handling of the line feed code of text string that was read TRUE: Delete. FALSE: Do not delete.			FALSE
Out	Read text string	Output	Text string that was read	Depends on data type.	---	---
EOF	End of file		Whether end of file was reached TRUE: Reached. FALSE: Not reached.			

	Boolean	Bit strings				Integers							Real numbers		Times, durations, dates, and text strings					
	BOOL	BYTE	WORD	DWORD	LWORD	USINT	UINT	UDINT	ULINT	SINT	INT	DINT	LINT	REAL	LREAL	TIME	DATE	TOD	DT	STRING
FileID				OK																
TrimLF	OK																			
Out																				OK
EOF	OK																			

Function

The FileGets instruction reads a text string of one line from the position of the file position indicator in the file specified by file ID *FileID* in the SD Memory Card. The file position indicator is set at the desired location in advance with the FileSeek instruction. Line endings are determined by a line feed code. The text string that is read is written to read text string *Out*. The following three line feeds are automatically detected: CR, LF, and CR+LF. If line feed designation *TrimLF* is TRUE, the line feed code is deleted from the text string before it is written to *Out*. If data is read to the end of the file, end of file *EOF* changes to TRUE. Otherwise, the value of *EOF* will be FALSE.

The following figure shows a programming example. Here, a text string of one line is read from a file, the line feed code is deleted, and the result is written to *pqr*.

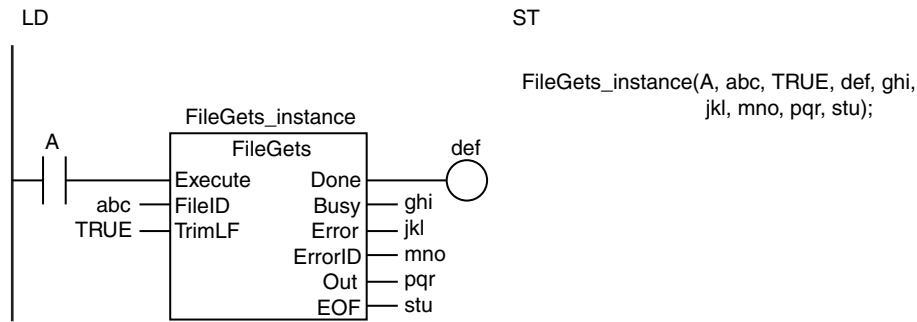

The FileGets instruction reads a text string of one line from the position of the file position indicator in the file specified by *FileID* in the SD Memory Card and stores it in the read text string *Out*. The line feed code is deleted.

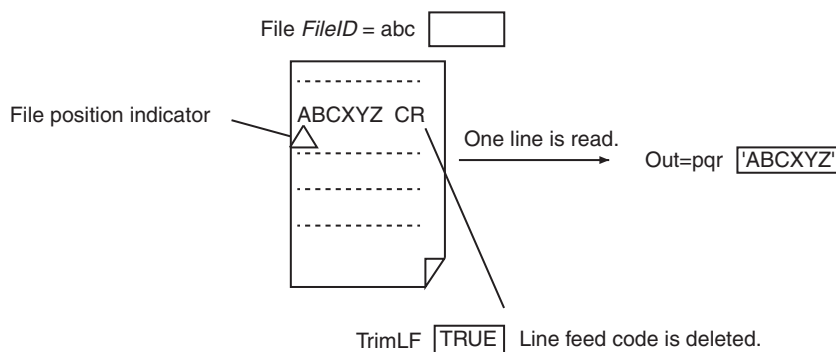

Related System-defined Variables

Name	Meaning	Data type	Description
_Card1Ready	SD Memory Card Ready Flag	BOOL	This flag indicates if the SD Memory Card can be accessed by instructions and communications commands.*1 TRUE: Can be used. FALSE: Cannot be used.
_Card1Protect*2	SD Memory Card Write Protected Flag	BOOL	This flag indicates if the SD Memory Card is write protected when it is inserted and ready to use. TRUE: Write protected. FALSE: Not write protected.

Name	Meaning	Data type	Description
_Card1Err*2	SD Memory Card Error Flag	BOOL	This flag indicates if an unspecified SD Memory Card (e.g., an SDHC card) is mounted or if the format is incorrect (i.e., not FAT16 or corrupted). TRUE: Error. FALSE: No error.
_Card1Access*2	SD Memory Card Access Flag	BOOL	This flag indicates if the SD Memory Card is currently being accessed. TRUE: Being accessed. FALSE: Not being accessed.
_Card1PowerFail	SD Memory Card Power Interruption Flag	BOOL	This flag indicates if an error occurred in completing processing when power was interrupted during access*3. This flag is not cleared automatically. TRUE: Error. FALSE: No error.

*1 For the NJ/NX-series, it is a precondition that the SD Memory Card is physically inserted and mounted normally. For an NY-series Controller, it is a precondition that the shared folder is detected by the Controller.

*2 These variables are not used for the NY-series Controller. They are fixed to FALSE.

*3 For the NJ/NX-series, this indicates an access to the SD Memory Card. For an NY-series Controller, this indicates an access to the shared folder.

Precautions for Correct Use

- Execution of this instruction is continued until processing is completed even if the value of *Execute* changes to FALSE or the execution time exceeds the task period. The value of *Done* changes to TRUE when processing is completed. Use this to confirm normal completion of processing.
- Refer to *Using this Section* on page 2-3 for a timing chart for *Execute*, *Done*, *Busy*, and *Error*.
- If the length of the one-line text string exceeds 1,986 bytes (with UTF-8 character codes, including the final NULL character), the first 1,985 bytes of the text string are stored in *Out* with a NULL character attached.
- You must use the FileOpen instruction to obtain the value for *FileID* before you execute this instruction.
- If the operating mode of the CPU Unit is changed to PROGRAM mode or when a major fault level Controller error occurs during instruction execution, the file is closed by the system. Any read/write operations that are in progress are completed to the end.
- Do not simultaneously access the same file. Perform exclusive control of SD Memory Card instructions in the user program.
- An error occurs in the following cases. *Error* will change to TRUE.
 - The SD Memory Card is not in a usable condition.
 - The file specified by *FileID* does not exist.
 - The file specified by *FileID* is being accessed.
 - The file specified by *FileID* was not opened in a reading mode.
 - An error that prevents access occurs during SD Memory Card access.

Sample Programming

Here, multiple text strings that are separated by CR codes are stored in a file named 'ABC.csv.' All of them are text strings of numbers. One line at a time is read from the file, the text strings are converted to integers, and the results are stored in INT array variable *InDat[]*. Processing is ended when all of the data to the end of the file is read.

It is assumed that this sample programming is in a periodic task.

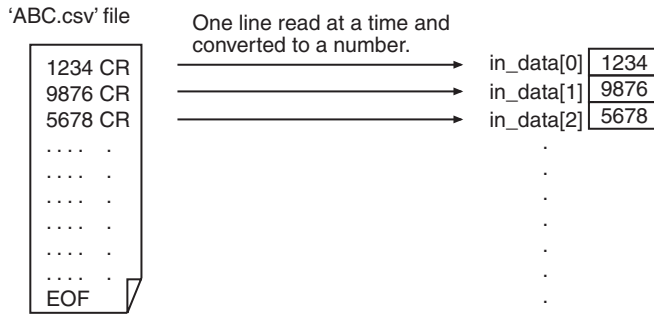

The processing procedure is as follows:

- 1** The FileOpen instruction is used to open the file 'ABC.csv.'
- 2** The FileGets instruction is used to read one line from the file.
- 3** The STRING_TO_INT instruction is used to convert the text string that was read to an integer and store it in *InDat[]*.
- 4** Steps 2 and 3 are repeated until the EOF (end of file).
- 5** The FileClose instruction is used to close the file.

LD

Internal Variables	Variable	Data type	Initial value	Comment
	OperatingEnd	BOOL	FALSE	Processing completed.
	Trigger	BOOL	FALSE	Execution condition
	Operating	BOOL	FALSE	Processing
	Index	INT	0	<i>InDat[]</i> element index
	Fid	DWORD	16#0	File ID
	InDat	ARRAY[0..999] OF INT	[1000(0)]	Integer data
	RS_instance	RS		
	FileOpen_instance	FileOpen		
	FileGets_instance	FileGets		
	FileClose_instance	FileClose		

External Variables	Variable	Data type	Comment
	_Card1Ready	BOOL	SD Memory Card Ready Flag

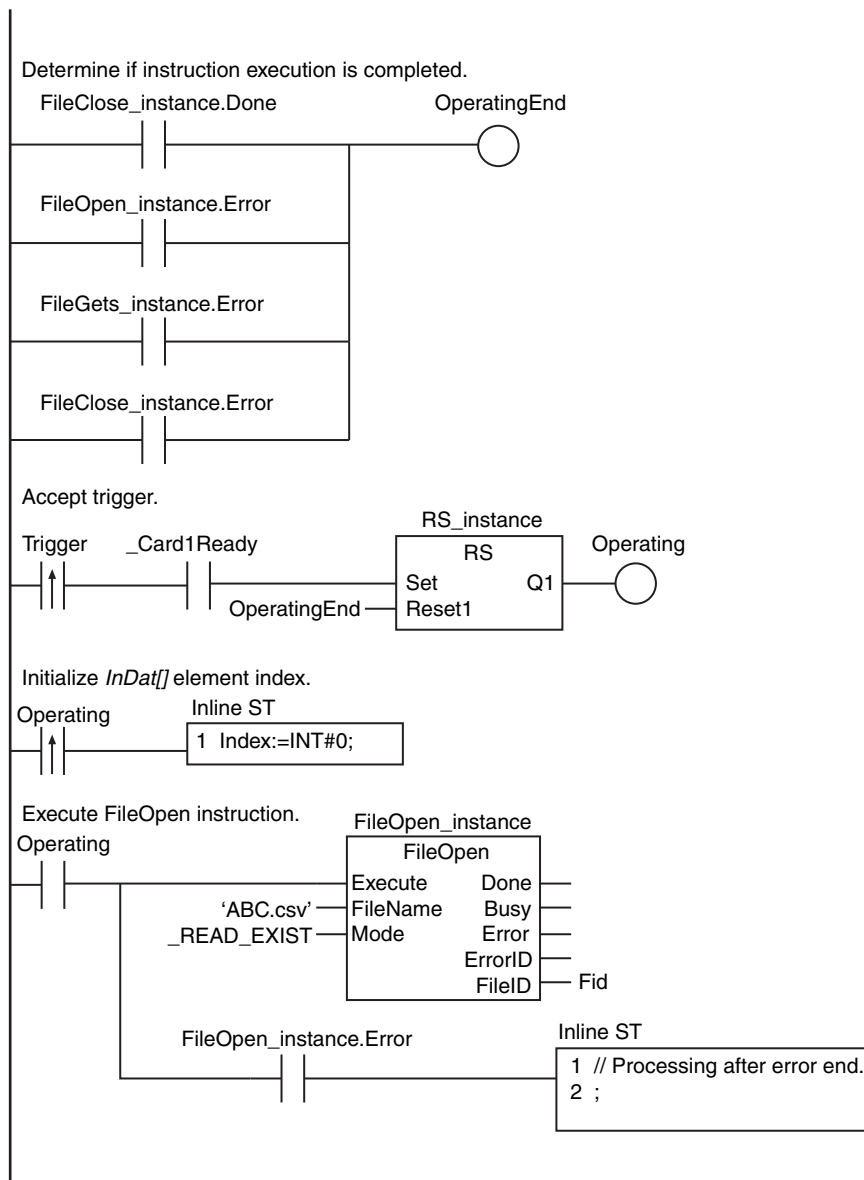

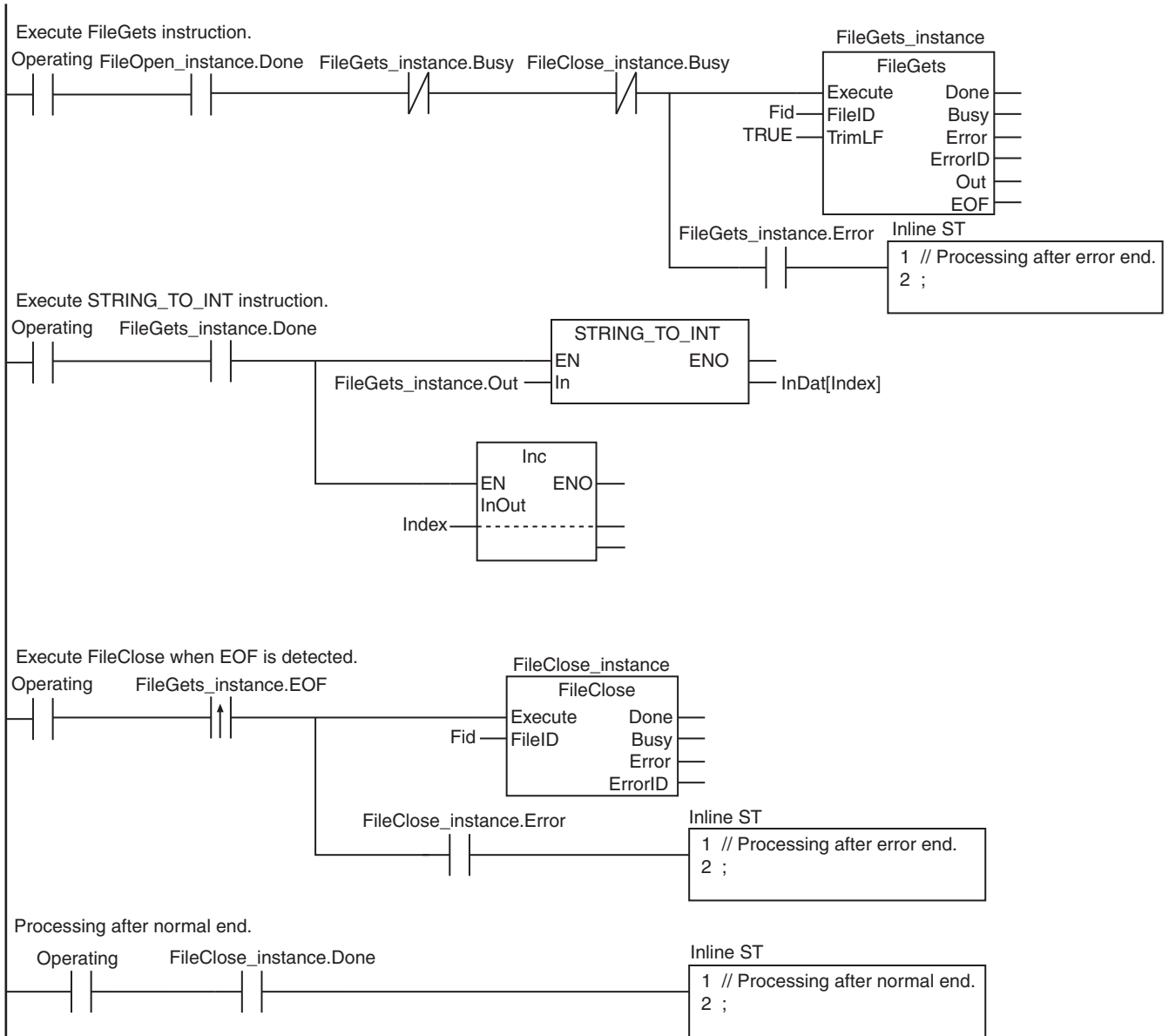

ST

Internal Variables	Variable	Data type	Initial value	Comment
	Trigger	BOOL	FALSE	Execution condition
	LastTrigger	BOOL	FALSE	Value of <i>Trigger</i> from previous task period
	OperatingStart	BOOL	FALSE	Processing started.
	Operating	BOOL	FALSE	Processing
	InDat	ARRAY[0..999] OF INT	[1000(0)]	Integer data
	Stage	INT	0	Stage change
	Index	INT	0	<i>InDat</i> [] element index
	Fid	DWORD	16#0	File ID
	FileOpen_instance	FileOpen		
	FileGets_instance	FileGets		
	FileClose_instance	FileClose		

External Variables	Variable	Data type	Comment
	_Card1Ready	BOOL	SD Memory Card Ready Flag

```
// Start sequence when Trigger changes to TRUE.
IF ( (Trigger=TRUE) AND (LastTrigger=FALSE) AND (_Card1Ready=TRUE) ) THEN
    OperatingStart:=TRUE;
    Operating      :=TRUE;
END_IF;
LastTrigger:=Trigger;

// Initialize instance.
IF (OperatingStart=TRUE) THEN
    FileOpen_instance(Execute:=FALSE);
    FileGets_instance(Execute:=FALSE);
    FileClose_instance(Execute:=FALSE);
    Stage :=INT#1;
    Index :=INT#0;
    OperatingStart:=FALSE;
END_IF;

// Execute instructions.
IF (Operating=TRUE) THEN
    CASE Stage OF
    1 : // Open file.
        FileOpen_instance(
            Execute:=TRUE,
            FileName:='ABC.csv', // File name
            Mode :=_READ_EXIST, // Read file.
            FileID =>Fid); // File ID

        IF (FileOpen_instance.Done=TRUE) THEN
            Stage:=INT#2; // Normal end
        END_IF;

        IF (FileOpen_instance.Error=TRUE) THEN
            Stage:=INT#99; // Error end
        END_IF;

    2 : // Read text string.
        FileGets_instance(
            Execute:=TRUE,
```

```

        FileID :=Fid,
        TrimLF :=TRUE);

IF (FileGets_instance.Done=TRUE) THEN
    // Convert the text string that was read to an integer.
    InDat[Index]:=STRING_TO_INT(FileGets_instance.Out);
    Index:=Index+INT#1;

    // Reached end of file.
    IF (FileGets_instance.EOF=TRUE) THEN
        Stage:=INT#3;    // Normal end
    ELSE
        FileGets_instance(Execute:=FALSE);
    END_IF;
END_IF;

IF (FileGets_instance.Error=TRUE) THEN
    Stage:=INT#99;    // Error end
END_IF;

3 :    // Close file.
FileClose_instance(
    Execute:=TRUE,
    FileID :=Fid);    // File ID

IF (FileClose_instance.Done=TRUE) THEN
    Operating:=FALSE; // Normal end
END_IF;

IF (FileClose_instance.Error=TRUE) THEN
    Stage:=INT#99;    // Error end
END_IF;

99 :    // Processing after error end.
Operating:=FALSE;
END_CASE;
END_IF;

```

FilePuts

The FilePuts instruction writes a text string to the specified file in the SD Memory Card.

Instruction	Name	FB/FUN	Graphic expression	ST expression
FilePuts	Put Text String	FB		FilePuts_instance(Execute, FileID, In, Done, Busy, Error, ErrorID);

Variables

Name	Meaning	I/O	Description	Valid range	Unit	Default
FileID	File ID	Input	ID of file to write	Depends on data type.	---	0
In	Write text string		Text string to write			"

	Boolean	Bit strings					Integers							Real numbers		Times, durations, dates, and text strings				
	BOOL	BYTE	WORD	DWORD	LWORD	USINT	UINT	UDINT	ULINT	SINT	INT	DINT	LINT	REAL	LREAL	TIME	DATE	TOD	DT	STRING
FileID				OK																
In																				OK

Function

The FilePuts instruction writes a text string to the position of the file position indicator in the file specified by file ID *FileID* in the SD Memory Card. The file position indicator is set at the desired location in advance with the FileSeek instruction. The contents of write text string *In* is written to the file.

The following figure shows a programming example. Here, the contents of array element *def[0]* is written to the file.

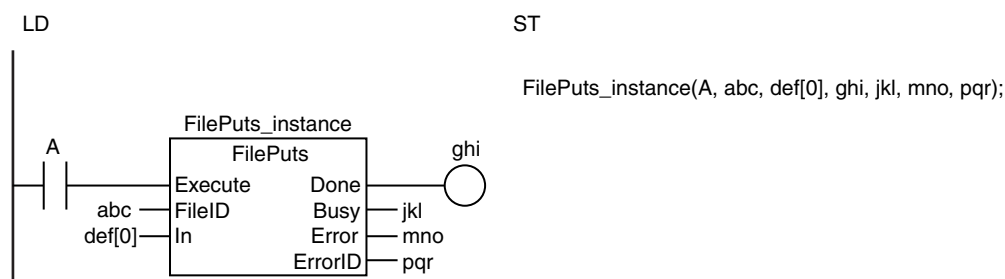

2 Instruction Descriptions

The FilePuts instruction writes the contents of the write text string *In* to the position of the file position indicator in the file specified by *FileID* in the SD Memory Card.

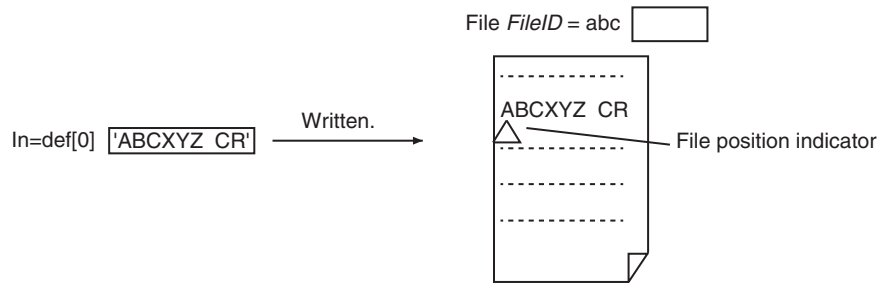

Related System-defined Variables

Name	Meaning	Data type	Description
_Card1Ready	SD Memory Card Ready Flag	BOOL	This flag indicates if the SD Memory Card can be accessed by instructions and communications commands.*1 TRUE: Can be used. FALSE: Cannot be used.
_Card1Protect*2	SD Memory Card Write Protected Flag	BOOL	This flag indicates if the SD Memory Card is write protected when it is inserted and ready to use. TRUE: Write protected. FALSE: Not write protected.
_Card1Err*2	SD Memory Card Error Flag	BOOL	This flag indicates if an unspecified SD Memory Card (e.g., an SDHC card) is mounted or if the format is incorrect (i.e., not FAT16 or corrupted). TRUE: Error. FALSE: No error.
_Card1Access*2	SD Memory Card Access Flag	BOOL	This flag indicates if the SD Memory Card is currently being accessed. TRUE: Being accessed. FALSE: Not being accessed.
_Card1PowerFail	SD Memory Card Power Interruption Flag	BOOL	This flag indicates if an error occurred in completing processing when power was interrupted during access*3. This flag is not cleared automatically. TRUE: Error. FALSE: No error.

*1 For the NJ/NX-series, it is a precondition that the SD Memory Card is physically inserted and mounted normally. For an NY-series Controller, it is a precondition that the shared folder is detected by the Controller.

*2 These variables are not used for the NY-series Controller. They are fixed to FALSE.

*3 For the NJ/NX-series, this indicates an access to the SD Memory Card. For an NY-series Controller, this indicates an access to the shared folder.

Additional Information

To create a line feed after you write the text string, add a line feed code to the end of *In*.

Precautions for Correct Use

- Execution of this instruction is continued until processing is completed even if the value of *Execute* changes to FALSE or the execution time exceeds the task period. The value of *Done* changes to TRUE when processing is completed. Use this to confirm normal completion of processing.
- Refer to *Using this Section* on page 2-3 for a timing chart for *Execute*, *Done*, *Busy*, and *Error*.
- You must use the FileOpen instruction to obtain the value for *FileID* before you execute this instruction.
- If the operating mode of the CPU Unit is changed to PROGRAM mode or when a major fault level Controller error occurs during instruction execution, the file is closed by the system. Any read/write operations that are in progress are completed to the end.
- Do not simultaneously access the same file. Perform exclusive control of SD Memory Card instructions in the user program.
- An error occurs in the following cases. *Error* will change to TRUE.
 - The SD Memory Card is not in a usable condition.
 - The SD Memory Card is write protected.
 - There is insufficient space available on the SD Memory Card.
 - The file specified by *FileID* does not exist.
 - The file specified by *FileID* is being accessed.
 - The file specified by *FileID* was not opened in a writing mode.
 - An error that prevents access occurs during SD Memory Card access.

Sample Programming

Here, 100 lines of the contents of INT array variable *Dat[0..9,0..99]* are stored in a file named 'ABC.csv' in CSV file format. Each line contains ten text strings of numbers. Commas are inserted between them. A CR+LF code is added to the end of the line. The procedure is as follows:

- 1** One element of *Dat[]* is converted to one text string and stored in the STRING variable *Temp*.
- 2** Except at the end of a line, a comma is added to the end of *Temp*. At the end of the line, a CR+LF code is added to the end of *Temp*. These are joined in the STRING variable *StrDat*.
- 3** When the end of the line is reached, *StrDat* is written to the file.
- 4** Steps 1 to 3 are repeated for 100 lines.

INT array

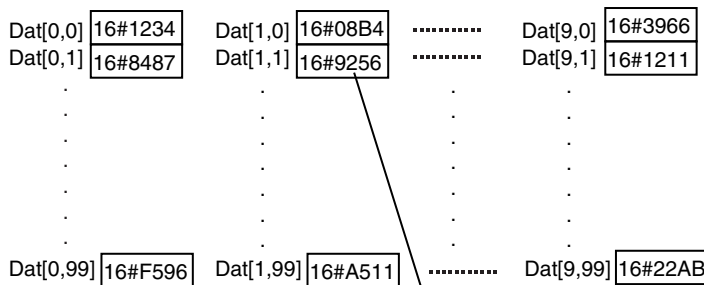

Converted to STRING data one at a time.



Commas are added between text strings, a CR code is added to the end, and the results are joined.

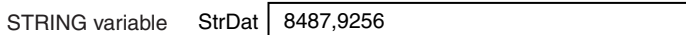

The line is written to the file when the end of the line is reached.

'ABC.csv' file

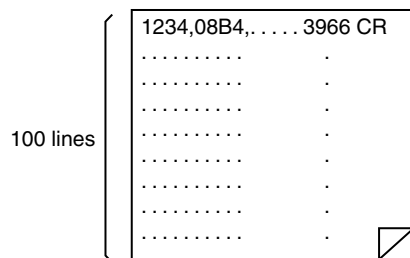

LD

Internal Variables	Variable	Data type	Initial value	Comment
	OperatingEnd	BOOL	FALSE	Processing completed.
	Trigger	BOOL	FALSE	Execution condition
	Operating	BOOL	FALSE	Processing
	Index0	INT	0	Column index
	Index1	INT	0	Row index
	Fid	DWORD	16#0	File ID
	StrDat	STRING[255]	"	Text string data
	Dat	ARRAY[0..99,0..9] OF INT	[1000(0)]	Numeric data
	Temp	STRING[255]	"	Temporary data
	RS_instance	RS		
	FileOpen_instance	FileOpen		
	FilePuts_instance	FilePuts		
	FileClose_instance	FileClose		

External Variables	Variable	Data type	Comment
	_Card1Ready	BOOL	SD Memory Card Ready Flag

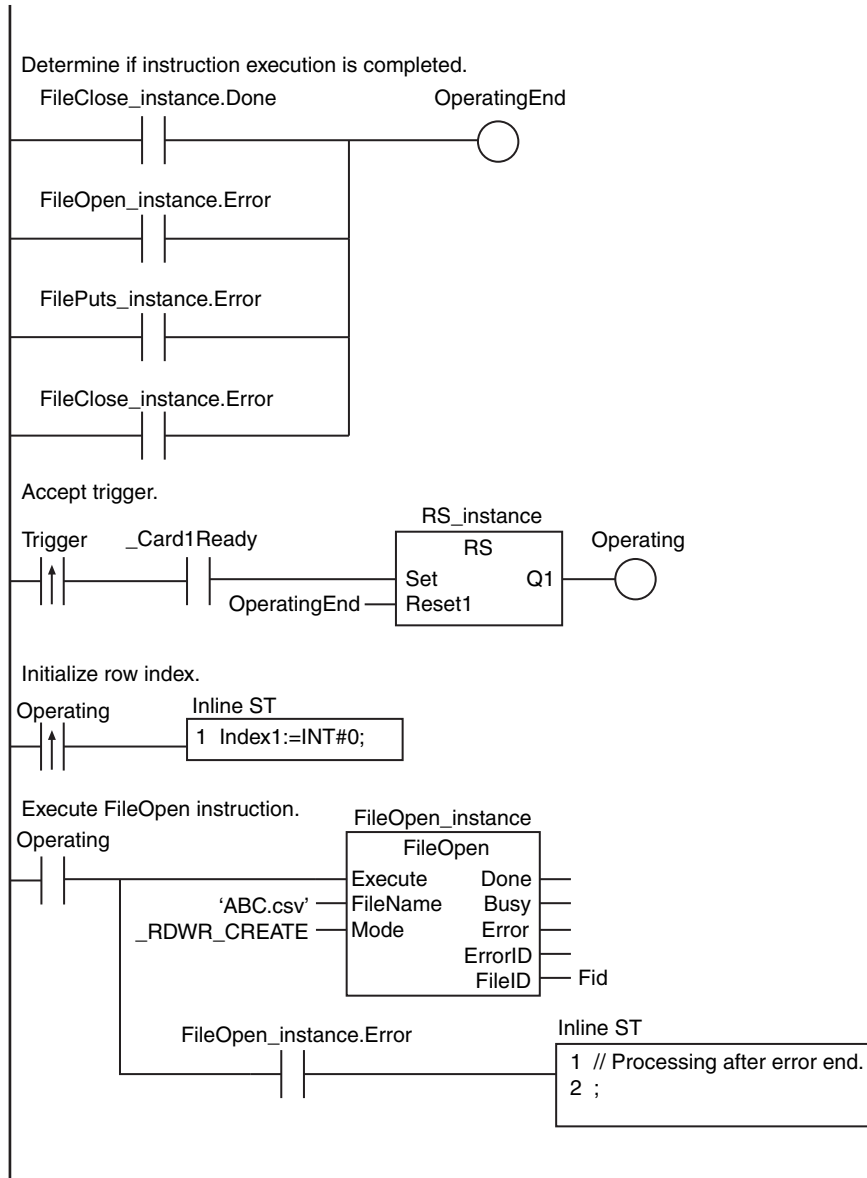

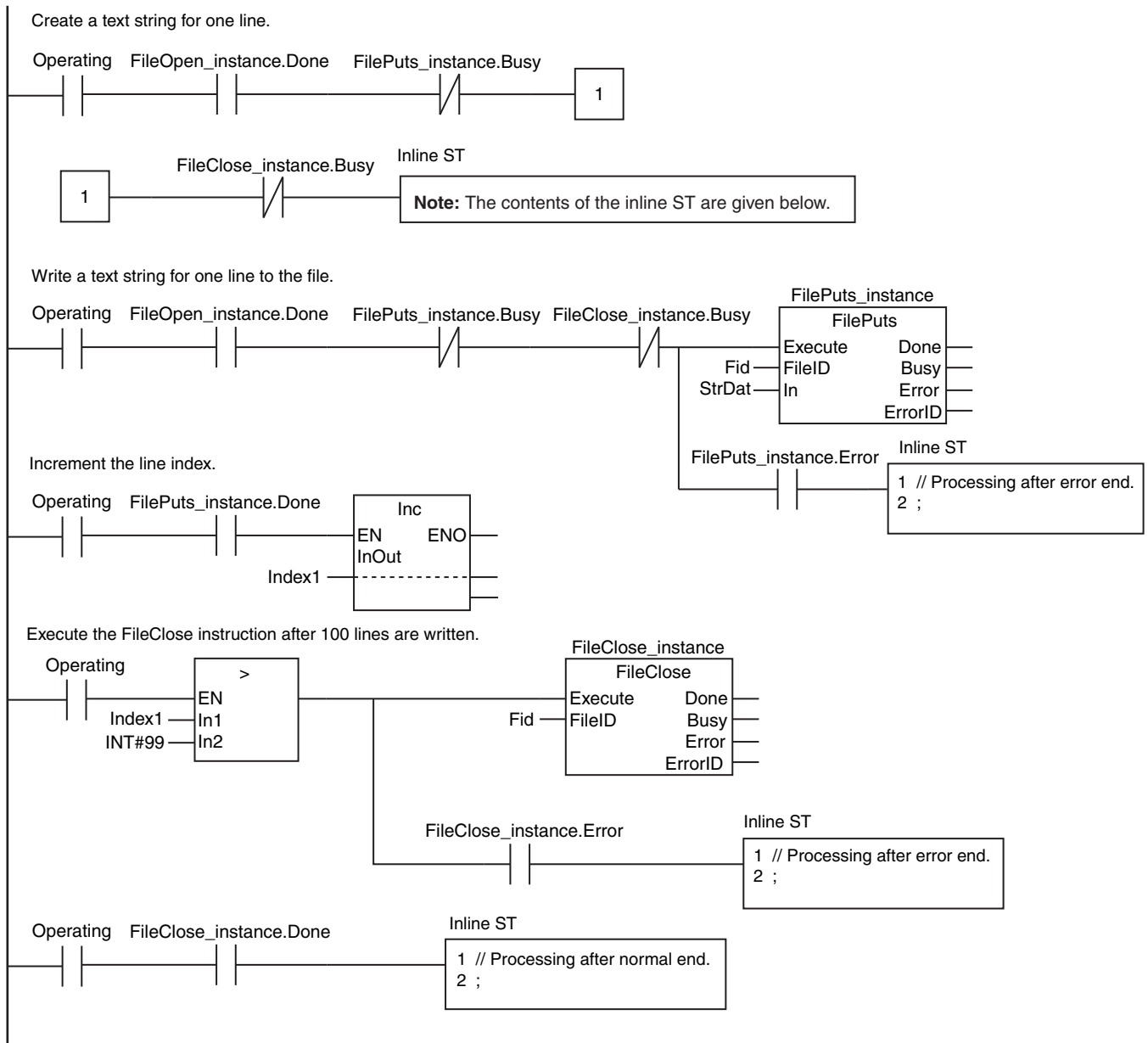

Contents of Inline ST

```
StrDat:='';

// Concatenate text strings 0 to 8.
FOR Index0:=INT#0 TO INT#8 BY INT#1 DO
    Temp :=INT_TO_STRING(Dat[Index1, Index0]);
    Temp :=CONCAT(In1:=Temp, In2:=',');
    StrDat:=CONCAT(In1:=StrDat, In2:=Temp);
END_FOR;

// Concatenate text string 9 and add CR+LF.
Temp :=INT_TO_STRING(Dat[Index1, Index0]);
Temp :=CONCAT(In1:=Temp, In2:='$r$1'); // CR+LF
StrDat:=CONCAT(In1:=StrDat, In2:=Temp);
```

ST

Internal Variables	Variable	Data type	Initial value	Comment
	Trigger	BOOL	FALSE	Execution condition
	LastTrigger	BOOL	FALSE	Value of <i>Trigger</i> from previous task period
	OperatingStart	BOOL	FALSE	Processing started.
	Operating	BOOL	FALSE	Processing
	Stage	INT	0	Stage change
	Index0	INT	0	Column index
	Index1	INT	0	Row index
	Fid	DWORD	16#0	File ID
	StrDat	STRING[255]	"	Text string data
	Dat	ARRAY[0..99,0..9] OF INT	[1000(0)]	Numeric data
	Temp	STRING[255]	"	Temporary data
	FileOpen_instance	FileOpen		
	FilePuts_instance	FilePuts		
	FileClose_instance	FileClose		

External Variables	Variable	Data type	Comment
	_Card1Ready	BOOL	SD Memory Card Ready Flag

```
// Start sequence when Trigger changes to TRUE.
IF ( (Trigger=TRUE) AND (LastTrigger=FALSE) AND (_Card1Ready=TRUE) ) THEN
    OperatingStart:=TRUE;
    Operating      :=TRUE;
END_IF;
LastTrigger:=Trigger;

// Initialize instance.
IF (OperatingStart=TRUE) THEN
    FileOpen_instance(Execute:=FALSE);
    FilePuts_instance(Execute:=FALSE);
    FileClose_instance(Execute:=FALSE);
    Stage :=INT#1;
    Index1 :=INT#0; // Initialize row index.
    OperatingStart:=FALSE;
END_IF;

// Execute instructions.
IF (Operating=TRUE) THEN
    CASE Stage OF
    1 : // Open file.
        FileOpen_instance(
            Execute :=TRUE,
            FileName:='ABC.csv', // File name
            Mode :=_RDWR_CREATE, // Read file
            FileID =>Fid); // File ID

        IF (FileOpen_instance.Done=TRUE) THEN
            Stage:=INT#2; // Normal end
        END_IF;

        IF (FileOpen_instance.Error=TRUE) THEN
            Stage:=INT#99; // Error end
        END_IF;
    END_CASE;
END_IF;
```

```

2 :      // Create a text string for one line.
      StrDat:='';

      // Concatenate text strings 0 to 8.
      FOR Index0 :=INT#0 TO INT#8 BY INT#1 DO
          Temp :=INT_TO_STRING(Dat[Index1, Index0]);
          Temp :=CONCAT(In1:=Temp, In2:=',');
          StrDat:=CONCAT(In1:=StrDat, In2:=Temp);
      END_FOR;

      // Concatenate text string 9 and add CR+LF.
      Temp :=INT_TO_STRING(Dat[Index1, Index0]);
      Temp :=CONCAT(In1:=Temp, In2:='$r$1');
      StrDat:=CONCAT(In1:=StrDat, In2:=Temp);

      Stage:=INT#3;

3 :      // Write text string.
      FilePuts_instance(
          Execute:=TRUE,
          FileID :=Fid,
          In      :=StrDat);

      IF (FilePuts_instance.Done=TRUE) THEN
          Index1:=Index1+INT#1;

          IF (Index1>INT#99) THEN // If 100 lines were written...
              Stage:=INT#4;
          ELSE
              FilePuts_instance(Execute:=FALSE);
              Stage:=INT#2;
          END_IF;
      END_IF;

      IF (FilePuts_instance.Error=TRUE) THEN
          Stage:=INT#99; // Error end
      END_IF;

4 :      // Close file.
      FileClose_instance(
          Execute:=TRUE,
          FileID :=Fid); // File ID

      IF (FileClose_instance.Done=TRUE) THEN
          Operating:=FALSE; // Normal end
      END_IF;

      IF (FileClose_instance.Error=TRUE) THEN
          Stage:=INT#99; // Error end
      END_IF;

99 :      // Processing after error end.
          Operating:=FALSE;
      END_CASE;
END_IF;

```

FileCopy

The FileCopy instruction copies the specified file in the SD Memory Card.

Instruction	Name	FB/FUN	Graphic expression	ST expression
FileCopy	Copy File	FB	<pre> FileCopy_instance ┌── FileCopy ──┐ │ Execute │ │ SrcFileName │ │ DstFileName │ │ OverWrite │ └── Done │ Busy │ Error │ ErrorID │ </pre>	FileCopy_instance(Execute, SrcFileName, DstFileName, OverWrite, Done, Busy, Error, ErrorID);

Variables

Name	Meaning	I/O	Description	Valid range	Unit	Default
SrcFile Name	Source file	Input	Name of file to copy	66 bytes max. (65 single-byte alphanumeric characters plus the final NULL character)	---	"
DstFile Name	Destination file		Name of destination file			
OverWrite	Overwrite enable		TRUE: Enable overwrite. FALSE: Prohibit overwrite.	Depends on data type.		FALSE

	Boolean	Bit strings					Integers							Real numbers		Times, durations, dates, and text strings				
	BOOL	BYTE	WORD	DWORD	LWORD	USINT	UINT	UDINT	ULINT	SINT	INT	DINT	LINT	REAL	LREAL	TIME	DATE	TOD	DT	STRING
SrcFile Name																				OK
DstFile Name																				OK
OverWrite	OK																			

Function

The FileCopy instruction copies the file specified by source file *SrcFileName* to designation file *DstFileName* in the SD Memory Card.

If a file with the name *DstFileName* already exists in the SD Memory Card, the following processing is performed depending on the value of overwrite enable *OverWrite*.

Value of <i>OverWrite</i>	Treatment
TRUE (Enable overwrite.)	The existing file is overwritten.
FALSE (Prohibit overwrite.)	The file is not overwritten and an error occurs.

The following figure shows a programming example. Here, the file 'DEF.bin' is overwritten with the file 'ABC.bin.'

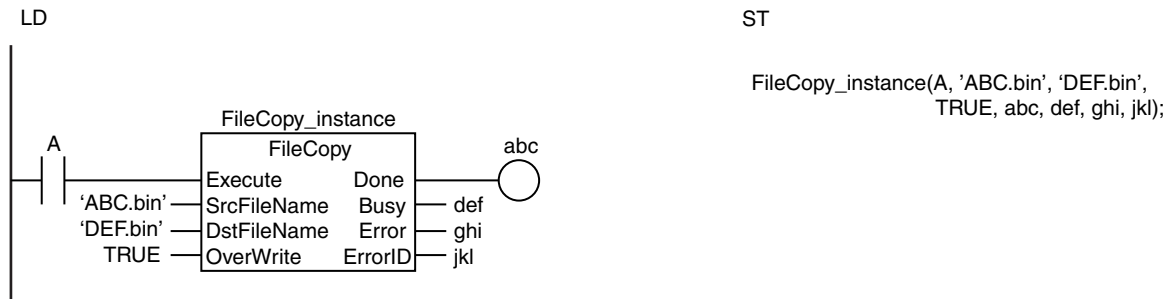

```

    ST
    FileCopy_instance(A, 'ABC.bin', 'DEF.bin',
    TRUE, abc, def, ghi, jkl);
  
```

The FileCopy instruction overwrites the file specified by source file *SrcFileName* to designation file *DstFileName* in the SD Memory Card.

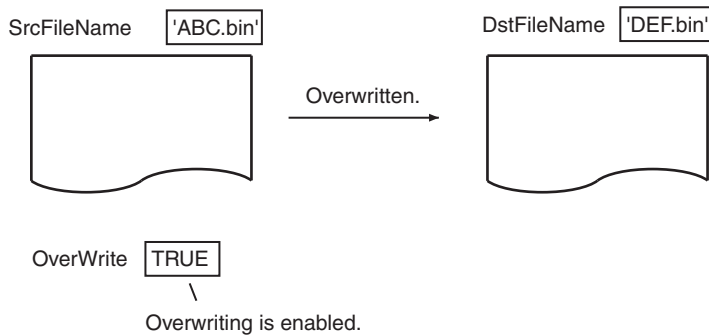

Related System-defined Variables

Name	Meaning	Data type	Description
_Card1Ready	SD Memory Card Ready Flag	BOOL	This flag indicates if the SD Memory Card can be accessed by instructions and communications commands.*1 TRUE: Can be used. FALSE: Cannot be used.
_Card1Protect*2	SD Memory Card Write Protected Flag	BOOL	This flag indicates if the SD Memory Card is write protected when it is inserted and ready to use. TRUE: Write protected. FALSE: Not write protected.
_Card1Err*2	SD Memory Card Error Flag	BOOL	This flag indicates if an unspecified SD Memory Card (e.g., an SDHC card) is mounted or if the format is incorrect (i.e., not FAT16 or corrupted). TRUE: Error. FALSE: No error.
_Card1Access*2	SD Memory Card Access Flag	BOOL	This flag indicates if the SD Memory Card is currently being accessed. TRUE: Being accessed. FALSE: Not being accessed.
_Card1PowerFail	SD Memory Card Power Interruption Flag	BOOL	This flag indicates if an error occurred in completing processing when power was interrupted during access*3. This flag is not cleared automatically. TRUE: Error. FALSE: No error.

- *1 For the NJ/NX-series, it is a precondition that the SD Memory Card is physically inserted and mounted normally. For an NY-series Controller, it is a precondition that the shared folder is detected by the Controller.
- *2 These variables are not used for the NY-series Controller. They are fixed to FALSE.
- *3 For the NJ/NX-series, this indicates an access to the SD Memory Card. For an NY-series Controller, this indicates an access to the shared folder.

Additional Information

The root directory of the file name is the top level of the SD Memory Card.

Precautions for Correct Use

- Execution of this instruction is continued until processing is completed even if the value of *Execute* changes to FALSE or the execution time exceeds the task period. The value of *Done* changes to TRUE when processing is completed. Use this to confirm normal completion of processing.
- Refer to *Using this Section* on page 2-3 for a timing chart for *Execute*, *Done*, *Busy*, and *Error*.
- If the copy operation fails, the file specified by *DstFileName* may remain in an incomplete state in the SD Memory Card.
- If a file is open when the operating mode of the CPU Unit is changed to PROGRAM mode or when a major fault level Controller error occurs, the file is closed by the system. Any read/write operations that are in progress are completed to the end.
- For an NJ/NX-series CPU Unit, if a file is open when the power supply is stopped with the SD Memory Card power supply switch, the file is not corrupted.
- For an NJ/NX-series CPU Unit, if a file is open and the SD Memory Card is removed before the SD Memory Card power supply switch is pressed, the contents of the file will sometimes be corrupted. Always turn OFF the power supply before removing the SD Memory Card.
- For an NJ/NX-series CPU Unit, if a file is open when the power supply is stopped or the SD Memory Card is removed, it will not be possible to read or write the file even if the SD Memory Card is inserted again.
- Do not simultaneously access the same file. Perform exclusive control of SD Memory Card instructions in the user program.
- An error occurs in the following cases. *Error* will change to TRUE.
 - The SD Memory Card is not in a usable condition.
 - The SD Memory Card is write protected.
 - There is insufficient space available on the SD Memory Card.
 - The file specified by *SrcFileName* does not exist.
 - The value of *SrcFileName* is not a valid file name.
 - The value of *DstFileName* is not a valid file name.
 - The maximum number of files or directories is exceeded.
 - The file specified by *SrcFileName* or *DstFileName* is already being accessed.
 - A file with the name *DstFileName* already exists and the value of *OverWrite* is FALSE.
 - A file with the name *DstFileName* already exists and the file is write protected.
 - If more than four SD Memory Card instructions that do not have a *FileID* variable (i.e., *FileWriteVar*, *FileReadVar*, *FileCopy*, *DirCreate*, *FileRemove*, *DirRemove*, and *FileRename*) are executed at the same time.
 - The value of *DstFileName* exceeds the maximum number of bytes allowed in a file name.
 - An error that prevents access occurs during SD Memory Card access.

Sample Programming

The following procedure is used to move a file.

- 1** The DirCreate instruction is used to create a directory called 'Dir1' in the SD Memory Card.
- 2** The FileCopy instruction is used to copy the file named 'ABC.bin' in the existing directory 'Dir0' to the directory 'Dir1.'
- 3** The DirRemove instruction is used to delete the directory 'Dir0' (the source of the copy).

1. Create directory.



2. Copy file.

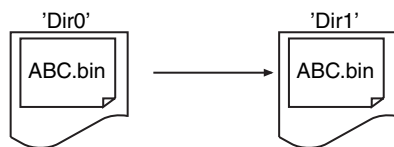

3. Delete directory.

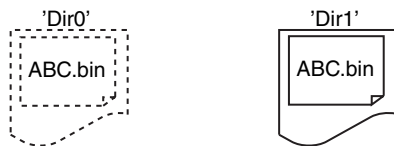

LD

Internal Variables	Variable	Data type	Initial value	Comment
	OperatingEnd	BOOL	FALSE	Processing completed.
	Trigger	BOOL	FALSE	Execution condition
	Operating	BOOL	FALSE	Processing
	RS_instance	RS		
	DirCreate_instance	DirCreate		
	FileCopy_instance	FileCopy		
	DirRemove_instance	DirRemove		

External Variables	Variable	Data type	Comment
	_Card1Ready	BOOL	SD Memory Card Ready Flag

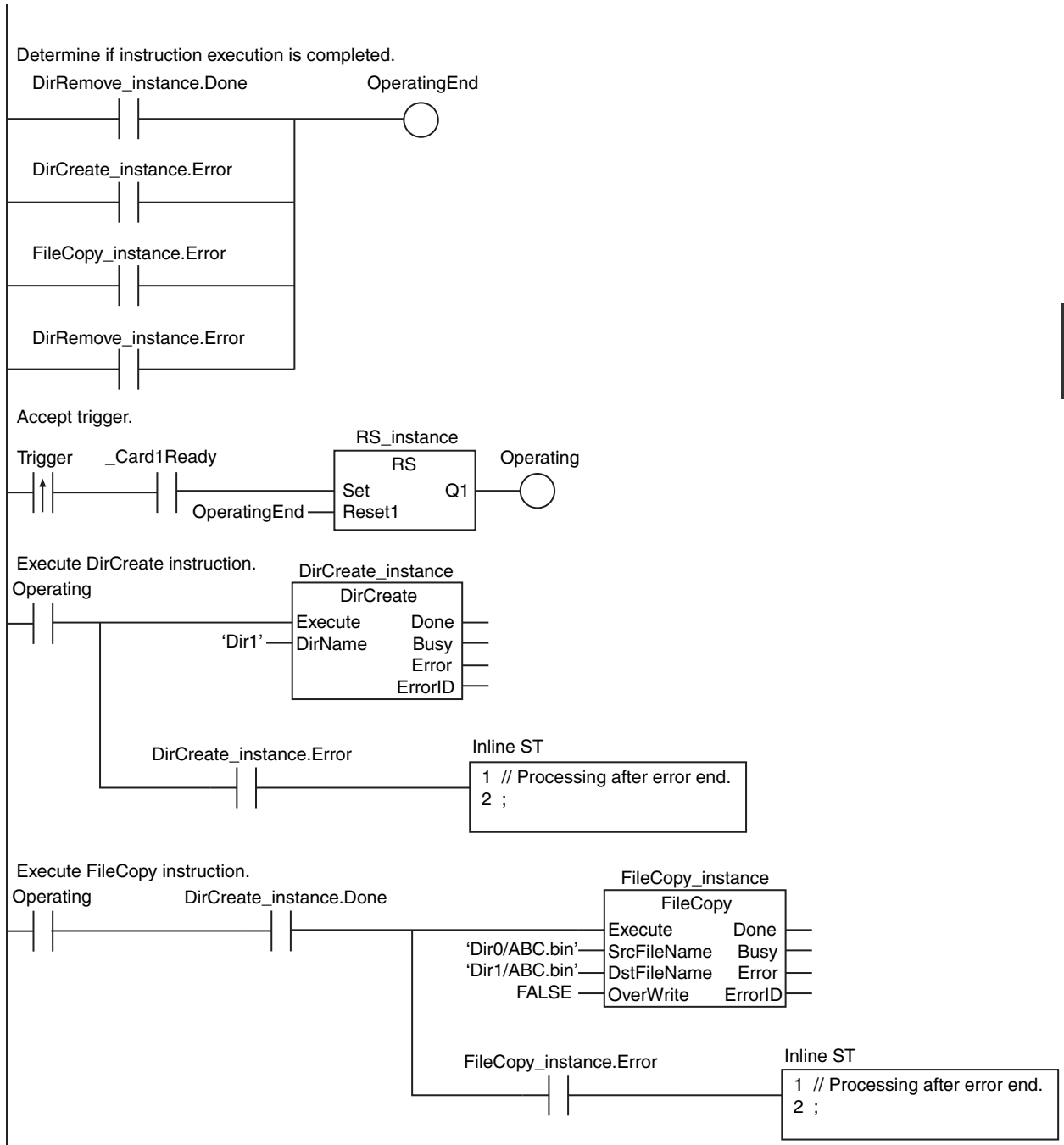

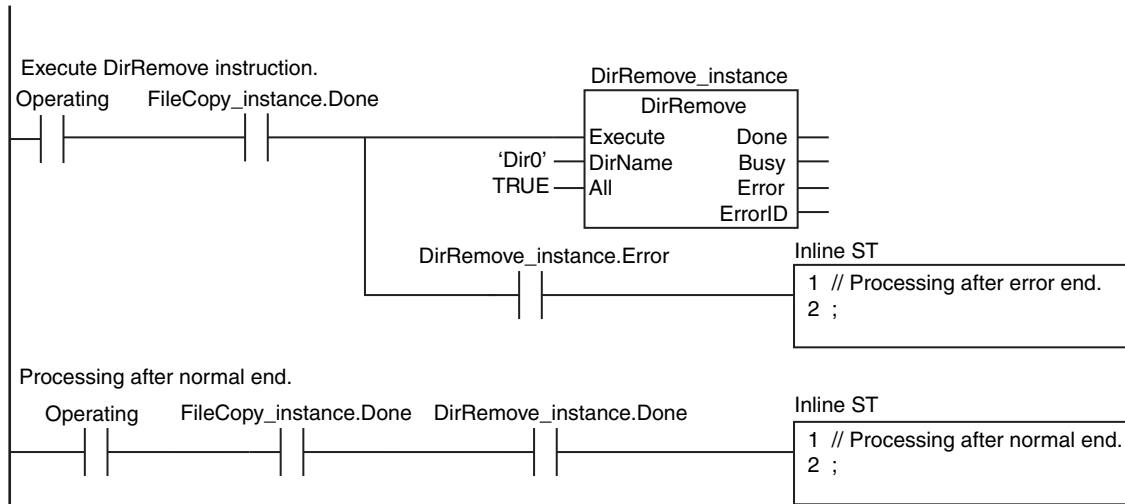

ST

Internal Variables	Variable	Data type	Initial value	Comment
	Trigger	BOOL	FALSE	Execution condition
	LastTrigger	BOOL	FALSE	Value of <i>Trigger</i> from previous task period
	OperatingStart	BOOL	FALSE	Processing started.
	Operating	BOOL	FALSE	Processing
	Stage	INT	0	Stage change
	DirCreate_instance	DirCreate		
	FileCopy_instance	FileCopy		
	DirRemove_instance	DirRemove		

External Variables	Variable	Data type	Comment
	_Card1Ready	BOOL	SD Memory Card Ready Flag

```

// Start sequence when Trigger changes to TRUE.
IF ( (Trigger=TRUE) AND (LastTrigger=FALSE) AND (_Card1Ready=TRUE) ) THEN
    OperatingStart:=TRUE;
    Operating      :=TRUE;
END_IF;
LastTrigger:=Trigger;

// Initialize instance.
IF (OperatingStart=TRUE) THEN
    DirCreate_instance(Execute:=FALSE);
    FileCopy_instance(Execute:=FALSE);
    DirRemove_instance(Execute:=FALSE);
    Stage              :=INT#1;
    OperatingStart:=FALSE;
END_IF;

// Execute instructions.
IF (Operating=TRUE) THEN
    CASE Stage OF
    1 : // Create directory.
        DirCreate_instance(
            Execute:=TRUE,
            DirName:='Dir1'); // Directory name

        IF (DirCreate_instance.Done=TRUE) THEN
            Stage:=INT#2; // Normal end
        END_IF;

        IF (DirCreate_instance.Error=TRUE) THEN
            Stage:=INT#99; // Error end
        END_IF;

    2 : // Copy file.
        FileCopy_instance(
            Execute      :=TRUE,
            SrcFileName:='Dir0/ABC.bin', // Name of file to copy
            DstFileName:='Dir1/ABC.bin', // Name of destination file
            OverWrite   :=FALSE); // Prohibit overwrite.

        IF (FileCopy_instance.Done=TRUE) THEN
            Stage:=INT#3;
        END_IF;
    END_CASE;
END_IF;

```

```
IF (FileCopy_instance.Error=TRUE) THEN
    Stage:=INT#99;
END_IF;

3 :      // Delete directory.
DirRemove_instance(
    Execute :=TRUE,
    DirName :='Dir0',    // Directory name
    All     :=TRUE);    // Delete files and subdirectories.

IF (DirRemove_instance.Done=TRUE) THEN
    Operating:=FALSE;    // Normal end
END_IF;

IF (DirRemove_instance.Error=TRUE) THEN
    Stage:=INT#99;      // Error end
END_IF;

99 :      // Processing after error end.
    Operating:=FALSE;
END_CASE;
END_IF;
```

FileRemove

The FileRemove instruction deletes the specified file from the SD Memory Card.

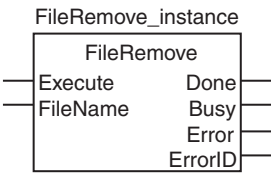
Instruction	Name	FB/FUN	Graphic expression	ST expression
FileRemove	Delete File	FB		FileRemove_instance(Execute, FileName, Done, Busy, Error, ErrorID);

Variables

Name	Meaning	I/O	Description	Valid range	Unit	Default
FileName	File name	Input	Name of file to delete	66 bytes max. (65 single-byte alphanumeric characters plus the final NULL character)	---	"

	Boolean	Bit strings				Integers							Real numbers	Times, durations, dates, and text strings						
	BOOL	BYTE	WORD	DWORD	LWORD	USINT	UINT	UDINT	ULINT	SINT	INT	DINT	LINT	REAL	LREAL	TIME	DATE	TOD	DT	STRING
FileName																				OK

Function

The FileRemove instruction deletes the file specified by file name *FileName* from the SD Memory Card. The following figure shows a programming example. Here, the file named 'ABC.bin' is deleted.

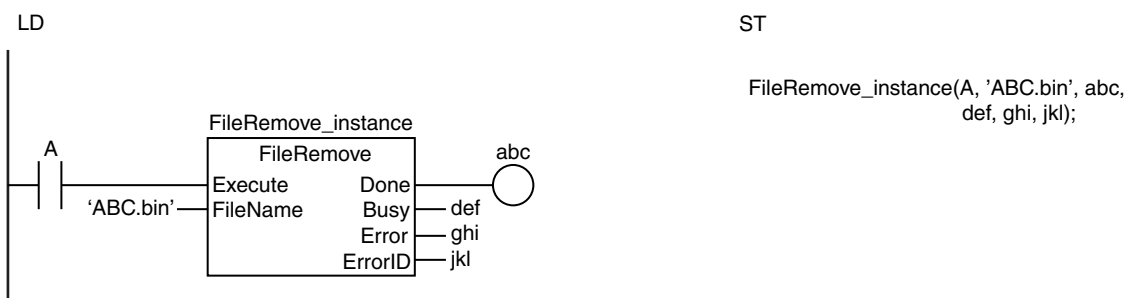

The FileRemove instruction deletes the file specified by *FileName* from the SD Memory Card.

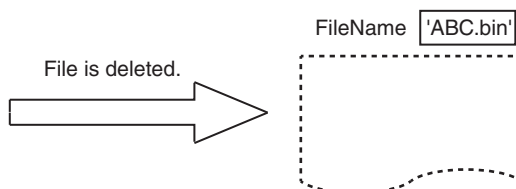

Related System-defined Variables

Name	Meaning	Data type	Description
_Card1Ready	SD Memory Card Ready Flag	BOOL	This flag indicates if the SD Memory Card can be accessed by instructions and communications commands.*1 TRUE: Can be used. FALSE: Cannot be used.
_Card1Protect*2	SD Memory Card Write Protected Flag	BOOL	This flag indicates if the SD Memory Card is write protected when it is inserted and ready to use. TRUE: Write protected. FALSE: Not write protected.
_Card1Err*2	SD Memory Card Error Flag	BOOL	This flag indicates if an unspecified SD Memory Card (e.g., an SDHC card) is mounted or if the format is incorrect (i.e., not FAT16 or corrupted). TRUE: Error. FALSE: No error.
_Card1Access*2	SD Memory Card Access Flag	BOOL	This flag indicates if the SD Memory Card is currently being accessed. TRUE: Being accessed. FALSE: Not being accessed.
_Card1PowerFail	SD Memory Card Power Interruption Flag	BOOL	This flag indicates if an error occurred in completing processing when power was interrupted during access*3. This flag is not cleared automatically. TRUE: Error. FALSE: No error.

*1 For the NJ/NX-series, it is a precondition that the SD Memory Card is physically inserted and mounted normally. For an NY-series Controller, it is a precondition that the shared folder is detected by the Controller.

*2 These variables are not used for the NY-series Controller. They are fixed to FALSE.

*3 For the NJ/NX-series, this indicates an access to the SD Memory Card. For an NY-series Controller, this indicates an access to the shared folder.

Additional Information

The root directory of the file name is the top level of the SD Memory Card.

Precautions for Correct Use

- Execution of this instruction is continued until processing is completed even if the value of *Execute* changes to FALSE or the execution time exceeds the task period. The value of *Done* changes to TRUE when processing is completed. Use this to confirm normal completion of processing.
- Refer to *Using this Section* on page 2-3 for a timing chart for *Execute*, *Done*, *Busy*, and *Error*.
- If a file is open when the operating mode of the CPU Unit is changed to PROGRAM mode or when a major fault level Controller error occurs, the file is closed by the system. Any read/write operations that are in progress are completed to the end.
- For an NJ/NX-series CPU Unit, if a file is open when the power supply is stopped with the SD Memory Card power supply switch, the file is not corrupted.
- For an NJ/NX-series CPU Unit, if a file is open and the SD Memory Card is removed before the SD Memory Card power supply switch is pressed, the contents of the file will sometimes be corrupted. Always turn OFF the power supply before removing the SD Memory Card.

- For an NJ/NX-series CPU Unit, if a file is open when the power supply is stopped or the SD Memory Card is removed, it will not be possible to read or write the file even if the SD Memory Card is inserted again.
- Do not simultaneously access the same file. Perform exclusive control of SD Memory Card instructions in the user program.
- An error occurs in the following cases. *Error* will change to TRUE.
 - The SD Memory Card is not in a usable condition.
 - The SD Memory Card is write protected.
 - The file specified by *FileName* does not exist.
 - The file specified by *FileName* is being accessed.
 - A file with the name *FileName* already exists and the file is write protected.
 - If more than four SD Memory Card instructions that do not have a *FileID* variable (i.e., FileWriteVar, FileReadVar, FileCopy, DirCreate, FileRemove, DirRemove, and FileRename) are executed at the same time.
 - The value of *FileName* exceeds the maximum number of characters allowed in a file name.
 - An error that prevents access occurs during SD Memory Card access.

Sample Programming

In this sample, the file named 'ABC.bin' is deleted from the SD Memory Card.

LD

Internal Variables	Variable	Data type	Initial value	Comment
	OperatingEnd	BOOL	FALSE	Processing completed.
	Trigger	BOOL	FALSE	Execution condition
	Operating	BOOL	FALSE	Processing
	RS_instance	RS		
	FileRemove_instance	FileRemove		

External Variables	Variable	Data type	Comment
	_Card1Ready	BOOL	SD Memory Card Ready Flag

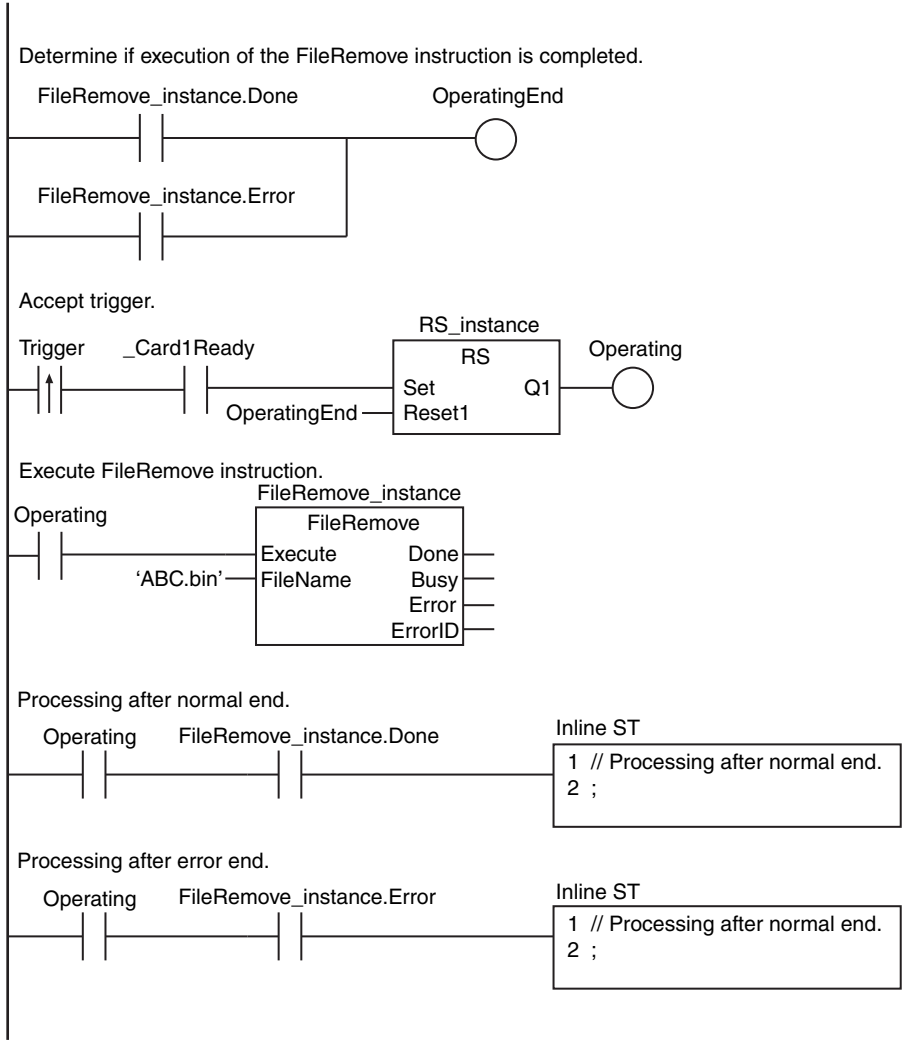

ST

Internal Variables	Variable	Data type	Initial value	Comment
	Trigger	BOOL	FALSE	Execution condition
	LastTrigger	BOOL	FALSE	Value of <i>Trigger</i> from previous task period
	OperatingStart	BOOL	FALSE	Processing started.
	Operating	BOOL	FALSE	Processing
	FileRemove_instance	FileRemove		

External Variables	Variable	Data type	Comment
	_Card1Ready	BOOL	SD Memory Card Ready Flag

```

// Start sequence when Trigger changes to TRUE.
IF ( (Trigger=TRUE) AND (LastTrigger=FALSE) AND (_Card1Ready=TRUE) ) THEN
    OperatingStart:=TRUE;
    Operating      :=TRUE;
END_IF;
LastTrigger:=Trigger;

// Initialize instance.
IF (OperatingStart=TRUE) THEN
    FileRemove_instance(Execute:=FALSE);
    OperatingStart:=FALSE;
END_IF;

// Execute FileRemove instruction.
IF (Operating=TRUE) THEN
    FileRemove_instance(
        Execute :=TRUE,
        FileName:='ABC.bin'); // File name

    IF (FileRemove_instance.Done=TRUE) THEN
        Operating:=FALSE; // Normal end
    END_IF;

    IF (FileRemove_instance.Error=TRUE) THEN
        Operating:=FALSE; // Error end
    END_IF;
END_IF;

```

FileRename

The FileRename instruction changes the name of the specified file or directory in the SD Memory Card.

Instruction	Name	FB/FUN	Graphic expression	ST expression
FileRename	Change File Name	FB	<div style="border: 1px solid black; padding: 5px; width: fit-content; margin: 0 auto;"> <div style="text-align: center;">FileRename_instance</div> <div style="text-align: center;">FileRename</div> <div style="display: flex; justify-content: space-between; border-top: 1px solid black; border-bottom: 1px solid black;"> Execute Done </div> <div style="display: flex; justify-content: space-between; border-bottom: 1px solid black;"> FileName Busy </div> <div style="display: flex; justify-content: space-between; border-bottom: 1px solid black;"> NewName Error </div> <div style="display: flex; justify-content: space-between;"> OverWrite ErrorID </div> </div>	FileRename_instance(Execute, FileName, NewName, OverWrite, Done, Busy, Error, ErrorID);

Variables

Name	Meaning	I/O	Description	Valid range	Unit	Default
FileName	Original file name	Input	Original file name	66 bytes max. (65 single-byte alphanumeric characters plus the final NULL character)	---	"
NewName	New file name		New file name			
OverWrite	Overwrite enable		TRUE: Enable overwrite. FALSE: Prohibit overwrite.	Depends on data type.		FALSE

	Boolean	Bit strings					Integers							Real numbers	Times, durations, dates, and text strings					
	BOOL	BYTE	WORD	DWORD	LWORD	USINT	UINT	UDINT	ULINT	SINT	INT	DINT	LINT	REAL	LREAL	TIME	DATE	TOD	DT	STRING
FileName																				OK
NewName																				OK
OverWrite	OK																			

Function

The FileRename instruction changes the name of the file or directory specified by original file name *FileName* to new file name *NewName* in the SD Memory Card.

If a file or directory with the name *NewName* already exists in the SD Memory Card, the following processing is performed depending on the value of overwrite enable *OverWrite*.

Value of <i>OverWrite</i>	Treatment
TRUE (Enable overwrite.)	The existing file or directory is overwritten.
FALSE (Prohibit overwrite.)	The file or directory is not overwritten and an error occurs.

The following figure shows a programming example. Here, the name of the file 'ABC.bin' is changed to 'DEF.bin.'

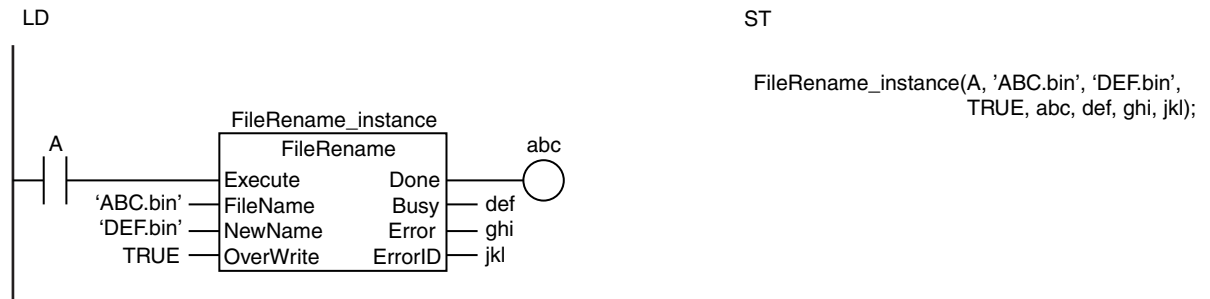

```
FileRename_instance(A, 'ABC.bin', 'DEF.bin',
TRUE, abc, def, ghi, jkl);
```

The FileRename instruction changes the name of the file specified by original file name *FileName* to new file name *NewName* in the SD Memory Card. If the file already exists, it is overwritten.

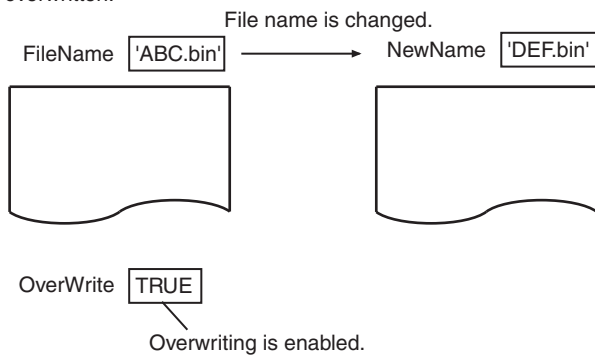

Related System-defined Variables

Name	Meaning	Data type	Description
_Card1Ready	SD Memory Card Ready Flag	BOOL	This flag indicates if the SD Memory Card can be accessed by instructions and communications commands.*1 TRUE: Can be used. FALSE: Cannot be used.
_Card1Protect*2	SD Memory Card Write Protected Flag	BOOL	This flag indicates if the SD Memory Card is write protected when it is inserted and ready to use. TRUE: Write protected. FALSE: Not write protected.
_Card1Err*2	SD Memory Card Error Flag	BOOL	This flag indicates if an unspecified SD Memory Card (e.g., an SDHC card) is mounted or if the format is incorrect (i.e., not FAT16 or corrupted). TRUE: Error. FALSE: No error.
_Card1Access*2	SD Memory Card Access Flag	BOOL	This flag indicates if the SD Memory Card is currently being accessed. TRUE: Being accessed. FALSE: Not being accessed.
_Card1PowerFail	SD Memory Card Power Interruption Flag	BOOL	This flag indicates if an error occurred in completing processing when power was interrupted during access*3. This flag is not cleared automatically. TRUE: Error. FALSE: No error.

- *1 For the NJ/NX-series, it is a precondition that the SD Memory Card is physically inserted and mounted normally. For an NY-series Controller, it is a precondition that the shared folder is detected by the Controller.
- *2 These variables are not used for the NY-series Controller. They are fixed to FALSE.
- *3 For the NJ/NX-series, this indicates an access to the SD Memory Card. For an NY-series Controller, this indicates an access to the shared folder.

Additional Information

The root directory of the file name is the top level of the SD Memory Card.

Precautions for Correct Use

- Execution of this instruction is continued until processing is completed even if the value of *Execute* changes to FALSE or the execution time exceeds the task period. The value of *Done* changes to TRUE when processing is completed. Use this to confirm normal completion of processing.
- Refer to *Using this Section* on page 2-3 for a timing chart for *Execute*, *Done*, *Busy*, and *Error*.
- If the directories are different for *FileName* and *NewName*, the file is moved to the directory that is specified with *NewName*.
- If a file is open when the operating mode of the CPU Unit is changed to PROGRAM mode or when a major fault level Controller error occurs, the file is closed by the system. Any read/write operations that are in progress are completed to the end.
- For an NJ/NX-series CPU Unit, if a file is open when the power supply is stopped with the SD Memory Card power supply switch, the file is not corrupted.
- For an NJ/NX-series CPU Unit, if a file is open and the SD Memory Card is removed before the SD Memory Card power supply switch is pressed, the contents of the file will sometimes be corrupted. Always turn OFF the power supply before removing the SD Memory Card.
- For an NJ/NX-series CPU Unit, if a file is open when the power supply is stopped or the SD Memory Card is removed, it will not be possible to read or write the file even if the SD Memory Card is inserted again.
- Do not simultaneously access the same file. Perform exclusive control of SD Memory Card instructions in the user program.
- An error occurs in the following cases. *Error* will change to TRUE.
 - The SD Memory Card is not in a usable condition.
 - The SD Memory Card is write protected.
 - The file directory specified with *FileName* does not exist.
 - The value of *FileName* or *NewName* is not a valid file name or directory name.
 - The file specified by *FileName* is being accessed.
 - There is a subdirectory in the directory that was specified for *FileName* and the value of *OverWrite* is TRUE.
 - A file with the name *NewName* already exists and the value of *OverWrite* is FALSE.
 - A file with the name *NewName* already exists, the file is write protected, and the value of *OverWrite* is TRUE.
 - If more than four SD Memory Card instructions that do not have a *FileID* variable (i.e., *FileWriteVar*, *FileReadVar*, *FileCopy*, *DirCreate*, *FileRemove*, *DirRemove*, and *FileRename*) are executed at the same time.
 - The value of *NewName* exceeds the maximum number of characters allowed in a file name or directory name.
 - An error that prevents access occurs during SD Memory Card access.
 - The maximum number of directories is exceeded.

Sample Programming

In this sample, the name of the file 'ABC.bin' is changed to 'DEF.bin' on the SD Memory Card.

LD

Internal Variables	Variable	Data type	Initial value	Comment
	OperatingEnd	BOOL	FALSE	Processing completed.
	Trigger	BOOL	FALSE	Execution condition
	Operating	BOOL	FALSE	Processing
	RS_instance	RS		
	FileRename_instance	FileRename		

External Variables	Variable	Data type	Comment
	_Card1Ready	BOOL	SD Memory Card Ready Flag

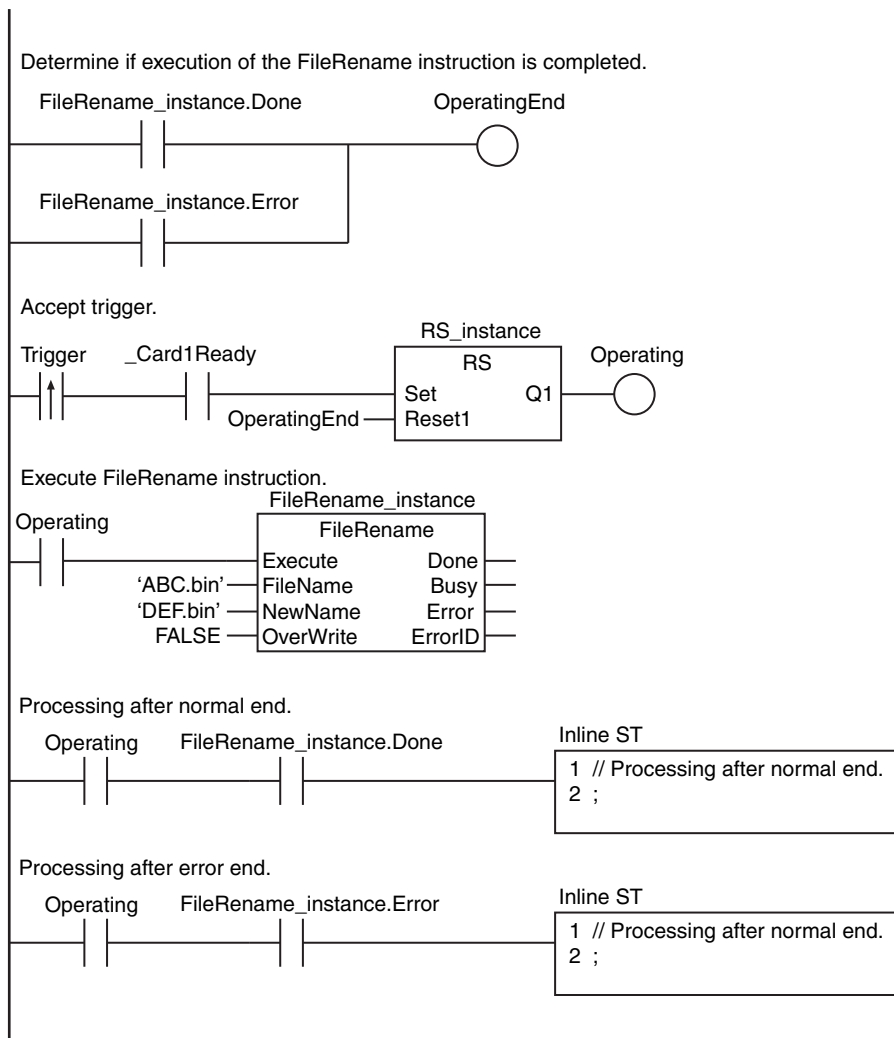

ST

Internal Variables	Variable	Data type	Initial value	Comment
	Trigger	BOOL	FALSE	Execution condition
	LastTrigger	BOOL	FALSE	Value of <i>Trigger</i> from previous task period
	OperatingStart	BOOL	FALSE	Processing started.
	Operating	BOOL	FALSE	Processing
	FileRename_instance	FileRename		

External Variables	Variable	Data type	Comment
	_Card1Ready	BOOL	SD Memory Card Ready Flag

```
// Start sequence when Trigger changes to TRUE.
IF ( (Trigger=TRUE) AND (LastTrigger=FALSE) AND (_Card1Ready=TRUE) ) THEN
    OperatingStart:=TRUE;
    Operating      :=TRUE;
END_IF;
LastTrigger:=Trigger;

// Initialize instance.
IF (OperatingStart=TRUE) THEN
    FileRename_instance(Execute:=FALSE);
    OperatingStart:=FALSE;
END_IF;

// Execute FileRename instruction.
IF (Operating=TRUE) THEN
    FileRename_instance(
        Execute :=TRUE,
        FileName :='ABC.bin', // Original file name
        NewName  :='DEF.bin', // New file name
        OverWrite:=FALSE);    // Prohibit overwrite.

    IF (FileRename_instance.Done=TRUE) THEN
        Operating:=FALSE;           // Normal end
    END_IF;

    IF (FileRename_instance.Error=TRUE) THEN
        Operating:=FALSE;           // Error end
    END_IF;
END_IF;
```

DirCreate

The DirCreate instruction creates a directory with the specified name in the SD Memory Card.

Instruction	Name	FB/FUN	Graphic expression	ST expression
DirCreate	Create Directory	FB		DirCreate_instance(Execute, DirName, Done, Busy, Error, ErrorID);

Variables

Name	Meaning	I/O	Description	Valid range	Unit	Default
DirName	Directory to create	Input	Name of directory to create	66 bytes max. (65 single-byte alphanumeric characters plus the final NULL character)	---	"

	Boolean	Bit strings				Integers							Real numbers	Times, durations, dates, and text strings						
	BOOL	BYTE	WORD	DWORD	LWORD	USINT	UINT	UDINT	ULINT	SINT	INT	DINT	LINT	REAL	LREAL	TIME	DATE	TOD	DT	STRING
DirName																				OK

Function

The DirCreate instruction creates a directory with the name specified by directory to create *Dir* in the SD Memory Card.

The following figure shows a programming example. Here, a directory named 'Dir0' is created.

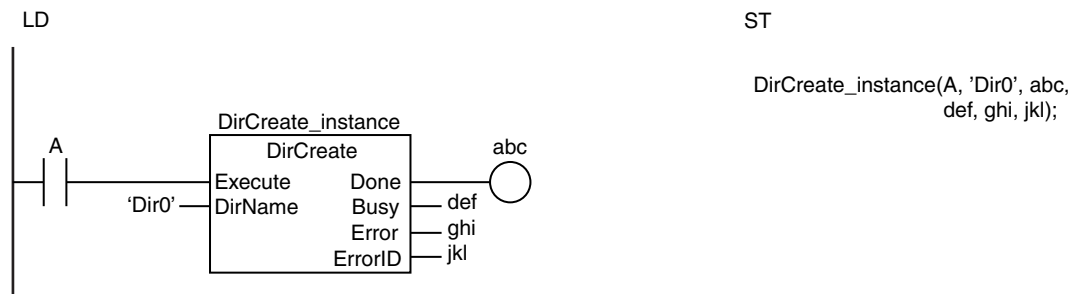

The DirCreate instruction creates a directory with the name specified by *DirName* in the SD Memory Card.

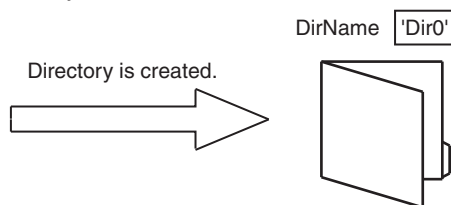

Related System-defined Variables

Name	Meaning	Data type	Description
_Card1Ready	SD Memory Card Ready Flag	BOOL	This flag indicates if the SD Memory Card can be accessed by instructions and communications commands.*1 TRUE: Can be used. FALSE: Cannot be used.
_Card1Protect*2	SD Memory Card Write Protected Flag	BOOL	This flag indicates if the SD Memory Card is write protected when it is inserted and ready to use. TRUE: Write protected. FALSE: Not write protected.
_Card1Err*2	SD Memory Card Error Flag	BOOL	This flag indicates if an unspecified SD Memory Card (e.g., an SDHC card) is mounted or if the format is incorrect (i.e., not FAT16 or corrupted). TRUE: Error. FALSE: No error.
_Card1Access*2	SD Memory Card Access Flag	BOOL	This flag indicates if the SD Memory Card is currently being accessed. TRUE: Being accessed. FALSE: Not being accessed.
_Card1PowerFail	SD Memory Card Power Interruption Flag	BOOL	This flag indicates if an error occurred in completing processing when power was interrupted during access*3. This flag is not cleared automatically. TRUE: Error. FALSE: No error.

*1 For the NJ/NX-series, it is a precondition that the SD Memory Card is physically inserted and mounted normally. For an NY-series Controller, it is a precondition that the shared folder is detected by the Controller.

*2 These variables are not used for the NY-series Controller. They are fixed to FALSE.

*3 For the NJ/NX-series, this indicates an access to the SD Memory Card. For an NY-series Controller, this indicates an access to the shared folder.

Additional Information

The root directory of the file name is the top level of the SD Memory Card.

Precautions for Correct Use

- Execution of this instruction is continued until processing is completed even if the value of *Execute* changes to FALSE or the execution time exceeds the task period. The value of *Done* changes to TRUE when processing is completed. Use this to confirm normal completion of processing.
- Refer to *Using this Section* on page 2-3 for a timing chart for *Execute*, *Done*, *Busy*, and *Error*.

- If a file is open when the operating mode of the CPU Unit is changed to PROGRAM mode or when a major fault level Controller error occurs, the file is closed by the system. Any read/write operations that are in progress are completed to the end.
- For an NJ/NX-series CPU Unit, if a file is open when the power supply is stopped with the SD Memory Card power supply switch, the file is not corrupted.
- For an NJ/NX-series CPU Unit, if a file is open and the SD Memory Card is removed before the SD Memory Card power supply switch is pressed, the contents of the file will sometimes be corrupted. For an NJ/NX-series CPU Unit, if a file is open and the SD Memory Card is removed before the SD Memory Card power supply switch is pressed, the contents of the file will sometimes be corrupted. Always turn OFF the power supply before removing the SD Memory Card.
- For an NJ/NX-series CPU Unit, if a file is open when the power supply is stopped or the SD Memory Card is removed, it will not be possible to read or write the file even if the SD Memory Card is inserted again.
- Do not simultaneously access the same file. Perform exclusive control of SD Memory Card instructions in the user program.
- An error occurs in the following cases. *Error* will change to TRUE.
 - The SD Memory Card is not in a usable condition.
 - The SD Memory Card is write protected.
 - There is insufficient space available on the SD Memory Card.
 - The maximum number of directories is exceeded.
 - The directory specified by *DirName* already exists.
 - If more than four SD Memory Card instructions that do not have a *FileID* variable (i.e., *FileWriteVar*, *FileReadVar*, *FileCopy*, *DirCreate*, *FileRemove*, *DirRemove*, and *FileRename*) are executed at the same time.
 - The value of *DirName* is not a valid directory name.
 - The value of *DirName* exceeds the maximum number of characters allowed in a directory name.
 - An error that prevents access occurs during SD Memory Card access.
 - The file specified by *FileName* is being accessed.

Sample Programming

Refer to the sample programming that is provided for the *FileCopy* instruction (page 2-1392).

DirRemove

The DirRemove instruction deletes the specified directory from the SD Memory Card.

Instruction	Name	FB/FUN	Graphic expression	ST expression
DirRemove	Delete Directory	FB	<pre> graph LR subgraph DirRemove_Instance [DirRemove_instance] subgraph DirRemove_Box [DirRemove] Execute[Execute] DirName[DirName] All[All] Done[Done] Busy[Busy] Error[Error] ErrorID[ErrorID] end end Execute --- DirRemove_Box DirName --- DirRemove_Box All --- DirRemove_Box DirRemove_Box --- Done DirRemove_Box --- Busy DirRemove_Box --- Error DirRemove_Box --- ErrorID </pre>	DirRemove_instance(Execute, DirName, All, Done, Busy, Error, ErrorID);

Variables

Name	Meaning	I/O	Description	Valid range	Unit	Default
DirName	Directory to delete	Input	Directory to delete	66 bytes max. (65 single-byte alphanumeric characters plus the final NULL character)	---	"
All	All designation		Specifies whether to delete files and subdirectories inside specified directory TRUE: Delete files and subdirectories. FALSE: Do not delete.	Depends on data type.		FALSE

	Boolean	Bit strings					Integers							Real numbers		Times, durations, dates, and text strings				
	BOOL	BYTE	WORD	DWORD	LWORD	USINT	UINT	UDINT	ULINT	SINT	INT	DINT	LINT	REAL	LREAL	TIME	DATE	TOD	DT	STRING
DirName																				OK
All	OK																			

Function

The DirRemove instruction deletes the directory with the name specified by directory to delete *Dir* from the SD Memory Card.

If there are files or subdirectories in the specified directory, the following processing is performed according to the value of all designation *All*.

Value of <i>All</i>	Treatment
TRUE	All files and subdirectories are deleted along with the specified directory.
FALSE	The specified directory is not deleted and an error occurs.

The following figure shows a programming example. Here, a directory named 'Dir1' is deleted.

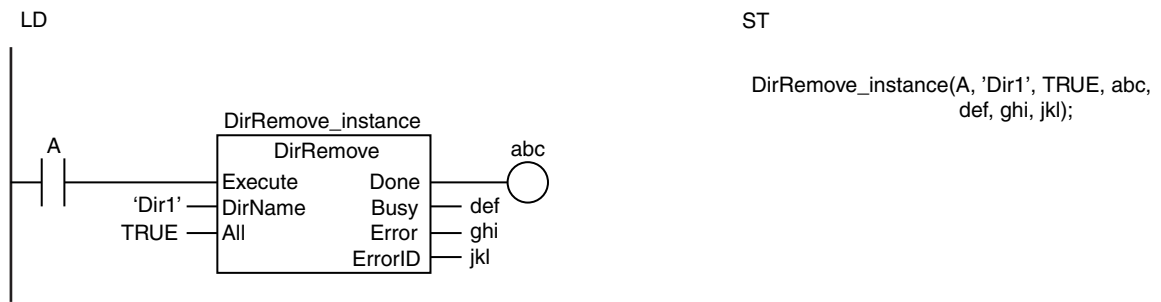

```

    DirRemove_instance(A, 'Dir1', TRUE, abc,
    def, ghi, jkl);
  
```

The DirRemove instruction deletes the directory with the name specified by *DirName* from the SD Memory Card. Files and subdirectories inside specified directory are deleted too.

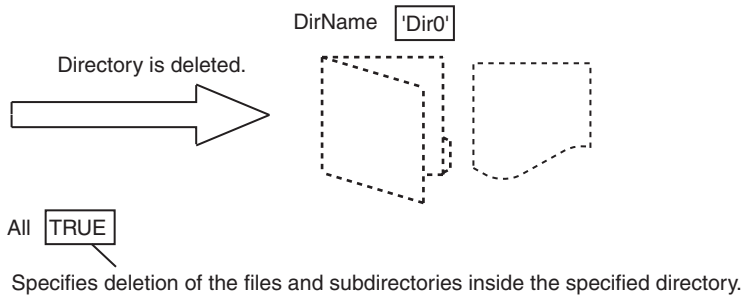

Related System-defined Variables

Name	Meaning	Data type	Description
_Card1Ready	SD Memory Card Ready Flag	BOOL	This flag indicates if the SD Memory Card can be accessed by instructions and communications commands.*1 TRUE: Can be used. FALSE: Cannot be used.
_Card1Protect*2	SD Memory Card Write Protected Flag	BOOL	This flag indicates if the SD Memory Card is write protected when it is inserted and ready to use. TRUE: Write protected. FALSE: Not write protected.
_Card1Err*2	SD Memory Card Error Flag	BOOL	This flag indicates if an unspecified SD Memory Card (e.g., an SDHC card) is mounted or if the format is incorrect (i.e., not FAT16 or corrupted). TRUE: Error. FALSE: No error.
_Card1Access*2	SD Memory Card Access Flag	BOOL	This flag indicates if the SD Memory Card is currently being accessed. TRUE: Being accessed. FALSE: Not being accessed.
_Card1PowerFail	SD Memory Card Power Interruption Flag	BOOL	This flag indicates if an error occurred in completing processing when power was interrupted during access*3. This flag is not cleared automatically. TRUE: Error. FALSE: No error.

*1 For the NJ/NX-series, it is a precondition that the SD Memory Card is physically inserted and mounted normally. For an NY-series Controller, it is a precondition that the shared folder is detected by the Controller.

*2 These variables are not used for the NY-series Controller. They are fixed to FALSE.

*3 For the NJ/NX-series, this indicates an access to the SD Memory Card. For an NY-series Controller, this indicates an access to the shared folder.

Additional Information

The root directory of the file name is the top level of the SD Memory Card.

Precautions for Correct Use

- Execution of this instruction is continued until processing is completed even if the value of *Execute* changes to FALSE or the execution time exceeds the task period. The value of *Done* changes to TRUE when processing is completed. Use this to confirm normal completion of processing.
- Refer to *Using this Section* on page 2-3 for a timing chart for *Execute*, *Done*, *Busy*, and *Error*.
- If a file is open when the operating mode of the CPU Unit is changed to PROGRAM mode or when a major fault level Controller error occurs, the file is closed by the system. Any read/write operations that are in progress are completed to the end.
- For an NJ/NX-series CPU Unit, if a file is open when the power supply is stopped with the SD Memory Card power supply switch, the file is not corrupted.
- For an NJ/NX-series CPU Unit, if a file is open and the SD Memory Card is removed before the SD Memory Card power supply switch is pressed, the contents of the file will sometimes be corrupted. Always turn OFF the power supply before removing the SD Memory Card.
- For an NJ/NX-series CPU Unit, if a file is open when the power supply is stopped or the SD Memory Card is removed, it will not be possible to read or write the file even if the SD Memory Card is inserted again.
- If the directory that is specified with *DirName* is write protected, an error occurs and the directory is not deleted. However, any files or directories that are not write-protected inside that directory are deleted.
- Do not simultaneously access the same file. Perform exclusive control of SD Memory Card instructions in the user program.
- An error occurs in the following cases. *Error* will change to TRUE.
 - The SD Memory Card is not in a usable condition.
 - The SD Memory Card is write protected.
 - If the value of *All* is TRUE and the directory specified with *DirName* is being accessed by another instruction.
 - If the value of *All* is FALSE and the directory specified with *DirName* contains a file or directory.
 - The directory specified by *DirName* is write-protected.
 - The directory that is specified with *DirName* contains write-protected files or write-protected directories.
 - If more than four SD Memory Card instructions that do not have a *FileID* variable (i.e., *FileWriteVar*, *FileReadVar*, *FileCopy*, *DirCreate*, *FileRemove*, *DirRemove*, and *FileRename*) are executed at the same time.
 - The directory specified by *DirName* does not exist.
 - The value of *DirName* exceeds the maximum number of characters allowed in a directory name.
 - An error that prevents access occurs during SD Memory Card access.

Sample Programming

Refer to the sample programming that is provided for the *FileCopy* instruction (page 2-1392).

BackupToMemoryCard

The BackupToMemoryCard instruction backs up data to an SD Memory Card.

Instruction	Name	FB/ FUN	Graphic expression	ST expression
BackupToMemoryCard	SD Memory Card Backup	FB		BackupToMemoryCard_instance(Execute, DirName, Cancel, Option, Done, Busy, Error, Canceled, ErrorID);

Variables

Name	Meaning	I/O	Description	Valid range	Unit	Default
DirName	Directory to save in	Input	Name of directory in which to save the backup data	64 bytes max. (63 single-byte alphanumeric characters plus the final NULL character)	---	''
Cancel	Cancel		Canceling the backup TRUE: Cancel FALSE: Do not cancel	Depends on data type.		FALSE
Option	For future expansion		This variable is for future expansion. It is not necessary to connect a parameter.	---		---
Canceled	Cancel completed	Output	A flag that indicates if canceling was completed TRUE: Canceling completed FALSE: Canceling failed	Depends on data type.	---	---

	Boolean	Bit strings				Integers							Real numbers		Times, durations, dates, and text strings					
	BOOL	BYTE	WORD	DWORD	LWORD	USINT	UINT	UDINT	ULINT	SINT	INT	DINT	LINT	REAL	LREAL	TIME	DATE	TOD	DT	STRING
DirName																				OK
Cancel	OK																			
Option	For future expansion. It is not necessary to connect a parameter.																			
Canceled	OK																			

Function

The BackupToMemoryCard instruction backs up data to an SD Memory Card.

This instruction performs the same processing as the processing that is performed for the front panel switch on the CPU Unit, the *_Card1BkupCmd* system-defined variable, or the SD Memory Card backup performed from the SD Memory Card Window on the Sysmac Studio.

Specify the name of the directory in which to save the backup data with *DirName*.

If the value of *DirName* is "" (i.e., a text string with a length of 0 characters), the backup data is saved in the root directory of the SD Memory Card.

DirName can be omitted. If you omit *DirName*, the following data is save in the following directory.

Instruction execution	Directory to save in
1st execution	Root directory
2nd execution and beyond	The previously specified directory

If the directory that is specified with *DirName* does not exist in the SD Memory Card, a new directory is created and the backup data is saved in it.

If a file with the same name as the backup file already exists in the directory specified with *DirName*, the backup file is overwritten.

If the value of *Cancel* changes to TRUE during backup processing, the backup processing is canceled. If backup processing is canceled, the backup file will not be created. If a backup file already exists in the directory specified with *DirName*, the backup file is not overwritten and remains unchanged.

You can cancel only the backup processing that is being executed for the same function block instance.

When canceling is completed, the value of *Canceled* changes to TRUE. Depending on when the value of *Cancel* changes to TRUE, it might be too late to cancel processing, and backup processing may be competed to the end. If canceling was not performed in time, the value of *Canceled* will be FALSE and the value of *Done* will be TRUE.

If the value of *Cancel* is TRUE, backup processing is not performed even if the value of *Execute* is TRUE.

Option is for future expansion. Do not connect a parameter to it.

Timing Chart for Canceling

Timing charts for the instruction variables are provided below for canceling.

● When Canceling Is Successful, and *Execute* Changes to FALSE Before *Canceled* Changes to TRUE

- Backup processing is executed when the value of *Execute* changes to TRUE. The value of *Busy* changes to TRUE.
- Backup processing is canceled when the value of *Cancel* changes to TRUE.
- When canceling is completed, the value of *Busy* changes to FALSE and the value of *Canceled* changes to TRUE.
- The value of *Execute* is changed to FALSE before the value of *Canceled* changes to TRUE.
- The value of *Canceled* changes to FALSE after one task period.
- Because canceling was successful, the value of *Done* changes to FALSE.

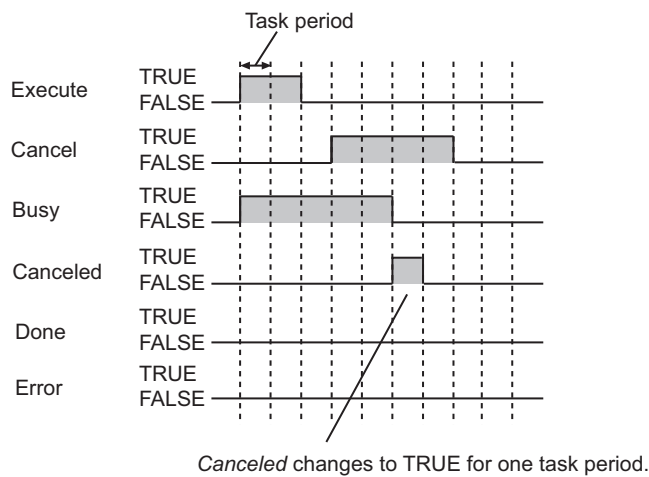

● **When Canceling Is Successful, and *Execute* Changes to FALSE After *Canceled* Changes to TRUE**

- Backup processing is executed when the value of *Execute* changes to TRUE. The value of *Busy* changes to TRUE.
- Backup processing is canceled when the value of *Cancel* changes to TRUE.
- When canceling is completed, the value of *Busy* changes to FALSE and the value of *Canceled* changes to TRUE.
- The value of *Execute* is changed to FALSE after the value of *Canceled* changes to TRUE.
- The value of *Canceled* remains TRUE until the value of *Execute* changes to FALSE.
- Because canceling was successful, the value of *Done* changes to FALSE.

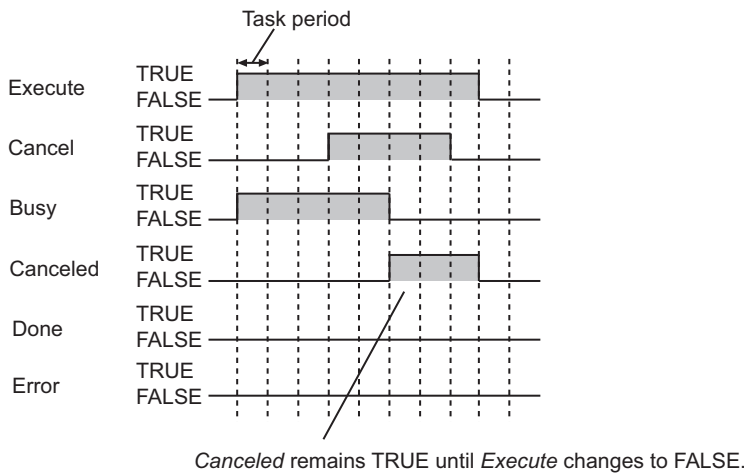

● **When Canceling Is Not Performed in Time**

- Backup processing is executed when the value of *Execute* changes to TRUE. The value of *Busy* changes to TRUE.
- The value of *Cancel* is changed to TRUE. Backup processing continues because canceling was not performed in time.
- When backup processing is completed, the value of *Busy* changes to FALSE.
- Backup processing was completed to the end, so the value of *Done* changes to TRUE.
- Canceling was not performed in time, so the value of *Canceled* remains FALSE.

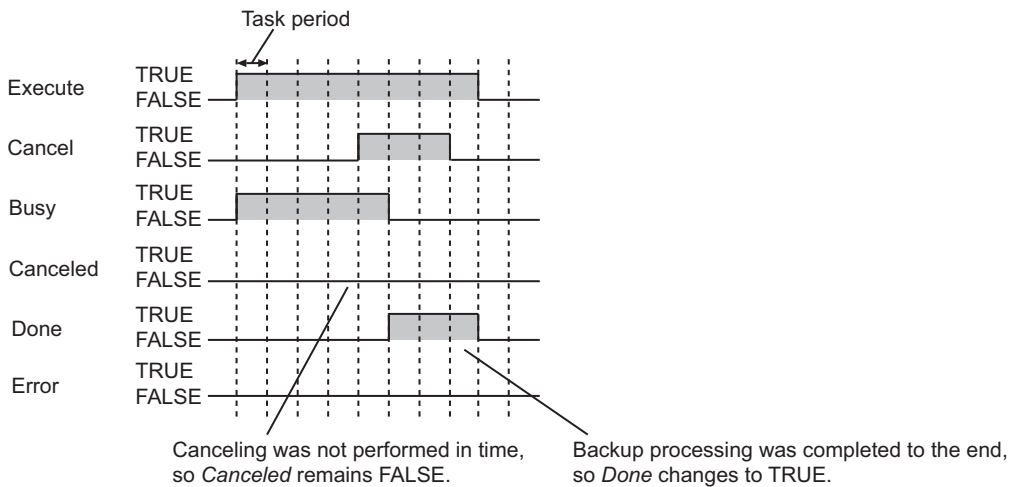

● **When the Value of *Execute* Is Changed to TRUE While the Value of *Cancel* Is TRUE**

- The value of *Cancel* is changed to TRUE.
- Backup processing is not executed even if the value of *Execute* is changed to TRUE. Therefore, the value of *Busy* remains FALSE.
- It is assumed that backup processing was canceled, so the value of *Canceled* changes to TRUE.
- When the value of *Execute* is changed to FALSE, the value of *Canceled* changes to FALSE.

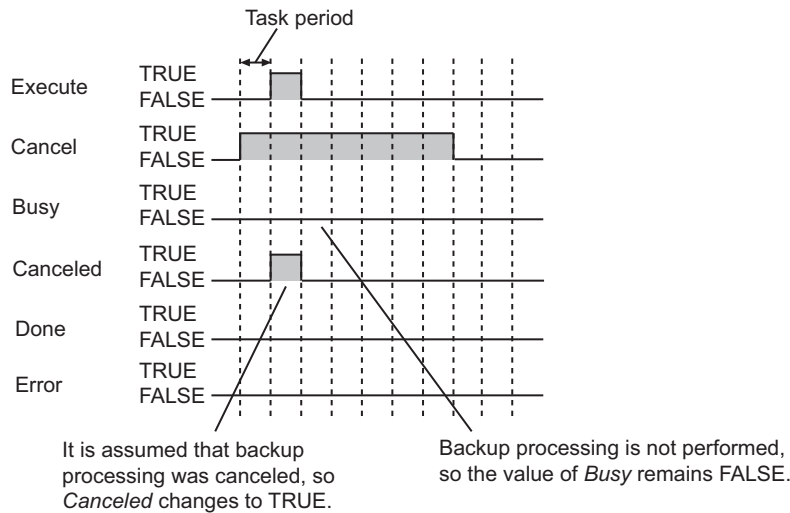

Notation Example

The following figure shows a programming example. The backup file is saved in a directory called Dir1.

LD

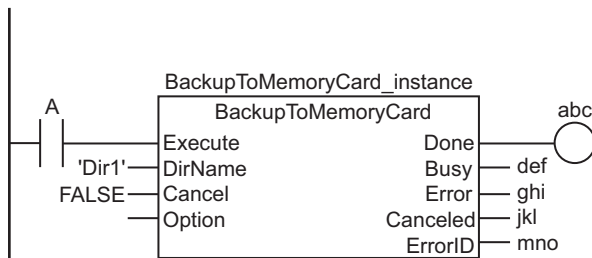

ST

```
BackupToMemoryCard_instance(A, 'Dir1', FALSE,
                             , abc, def, ghi, jkl,
                             mno);
```

Related System-defined Variables

Variable	Name	Data type	Description
_Card1Ready	SD Memory Card Ready Flag	BOOL	This flag indicates if the SD Memory Card can be accessed by instructions and communications commands.*1 TRUE: Can be used. FALSE: Cannot be used.
_Card1Protect*2	SD Memory Card Write Protected Flag	BOOL	This flag indicates if the SD Memory Card is write protected when it is inserted and ready to use. TRUE: Write protected. FALSE: Not write protected.
_Card1Err*2	SD Memory Card Error Flag	BOOL	This flag indicates if an unspecified SD Memory Card (e.g., an SDHC card) is mounted or if the format is incorrect (i.e., not FAT16 or corrupted). TRUE: Error. FALSE: No error.
_Card1Access*2	SD Memory Card Access Flag	BOOL	This flag indicates if the SD Memory Card is currently being accessed. TRUE: Being accessed. FALSE: Not being accessed.
_Card1Deteriorated*2	SD Memory Card Life Warning Flag	BOOL	This flag indicates if the end of the life of the SD Memory Card is detected. TRUE: End of life detected. FALSE: Not detected.
_Card1PowerFail	SD Memory Card Power Interruption Flag	BOOL	This flag indicates if an error occurred in completing processing when power was interrupted during access*3. This flag is not cleared automatically. TRUE: Error. FALSE: No error.
_BackupBusy	Backup Function Busy Flag	BOOL	This flag indicates if a backup, restoration, or verification is in progress. TRUE: Backup, restore, or compare operation is in progress. FALSE: Backup, restore, or compare operation is not in progress.

*1 For the NJ/NX-series, it is a precondition that the SD Memory Card is physically inserted and mounted normally. For an NY-series Controller, it is a precondition that the shared folder is detected by the Controller.

*2 These variables are not used for the NY-series Controller. They are fixed to FALSE.

*3 For the NJ/NX-series, this indicates an access to the SD Memory Card. For an NY-series Controller, this indicates an access to the shared folder.

Additional Information

- Refer to the *NJ/NX-series CPU Unit Software User's Manual* (Cat. No. W501) or *NY-series Industrial Panel PC / Industrial Box PC Software User's Manual* (Cat. No. W558) for details on the backup functions.
- The root directory of the file name is the top level of the SD Memory Card.

Precautions for Correct Use

- Execution of this instruction is continued until processing is completed even if the value of *Execute* changes to FALSE or the execution time exceeds the task period. The value of *Done* changes to TRUE when processing is completed. Use this to confirm normal completion of processing.
- Refer to *Using this Section* (page 2-3) for a timing chart for *Execute*, *Done*, *Busy*, and *Error*.
- For an NJ/NX-series CPU Unit, if a file is open and the SD Memory Card is removed before the SD Memory Card power supply switch is pressed, the contents of the file will sometimes be corrupted. Always turn OFF the power supply before removing the SD Memory Card.
- Even if data backup to the SD Memory Card is prohibited, you can execute this instruction to backup the data. No error will occur.
- The values of the following system-defined variables that are related to backup do not change when this instruction is executed.
 - SD Memory Card Backup Command: `_CardBkupCmd`
 - SD Memory Card Backup Status: `_Card1BkupSta`
- Do not read or write backup-related files during execution of this instruction. If you read a file that is being written, unexpected processing may occur.
- Backup processing will continue even if the operating mode of the CPU Unit is changed during execution of this instruction. If you change the operating mode from RUN mode to PROGRAM mode and then back to RUN mode, the value of *Busy* will be FALSE even if backup processing is in progress. If you cancel backup processing under that condition, the value of *Canceled* will change to TRUE.
- An error will occur in the following cases. *Error* will change to TRUE.
 - The SD Memory Card is not in a usable condition.
 - The SD Memory Card is write protected.
 - There is insufficient space available on the SD Memory Card.
 - The maximum number of files or directories is exceeded.
 - A file already exists with the same name as the name specified with *DirName*.
 - The value of *DirName* is not a valid directory name.
 - An error that prevents access occurs during SD Memory Card access.
 - Another backup operation is already in progress.
 - Backup processing failed.



Version Information

A CPU Unit with unit version 1.08 or later and Sysmac Studio version 1.09 or higher are required to use this instruction.

Sample Programming

In this example, the BackupToMemoryCard instruction backs up data to an SD Memory Card every day just after midnight. The backup-related files are stored in directories named /Backup/yyyy-mm-dd in the SD Memory Card. The directory name gives the date when the backup was executed. “yyyy” is the year, “mm” is the month, and “dd” is the day of the month.

Touch Panel Specifications

This example assumes that a touch panel is connected to the Controller.

The touch panel has the following lamps.

Lamp name	Description
Backup normal end lamp	Lights when backup processing ends normally.
Backup canceled lamp	Lights when backup processing is successfully canceled.
Backup error end lamp	Lights when backup processing ends in an error.
SD Memory Card life warning lamp	Lights when the life of the SD Memory Card was exceeded.
SD Memory Card power interrupted lamp	Lights when power to the SD Memory Card was interrupted during backup processing.

The touch panel also has the following buttons.

Button name	Operation when button is pressed
Lamps OFF button	Turns OFF the Backup Normal End Lamp, Backup Canceled Lamp, Backup Error End Lamp, and SD Memory Card Power Interrupted Lamp.
Cancel button	Cancels the backup.

Global Variables

Variable	Data type	Initial value	Comment
PTOut_Warning_SDLife	BOOL	FALSE	Output to SD Memory Card life warning lamp
PTOut_Warning_PwrFail_onBackup	BOOL	FALSE	Output to SD Memory Card power interrupted lamp
PTOut_Done	BOOL	FALSE	Output to backup normal end lamp
PTOut_Cancel	BOOL	FALSE	Output to backup canceled lamp
PTOut_Error	BOOL	FALSE	Output to backup error end lamp
PTIn_Check_Backup	BOOL	FALSE	Input from lamps OFF button
PTIn_Cancel	BOOL	FALSE	Input from cancel button

LD

Internal Variables	Variable	Data type	Initial value	Comment
	CardOK	BOOL	FALSE	SD Memory Card Normal Flag
	Backup_inst	BackupToMemory-Card		Instance of Backup-ToMemoryCard instruction
	PreviousDay	USINT	0	Date of previous task period
	CurrentDT	DATE_AND_TIME	ST#1970-01-01-00:00:00.000000000	Current date and time
	Current_sDt	_sDT	(Year:=0, Month:=0, Day:=0, Hour:=0, Min:=0, Sec:=0, NSec:=0)	The current date and time separated into the year, month, day, hour, minutes, seconds, and nanoseconds.
	BackupCondition	BOOL	FALSE	Backup Condition Established Flag
	tmpString	STRING[256]	"	Temporary text string used when creating directory name
	tmpString2	STRING[256]	"	Temporary text string used when creating directory name
	BackupPath	STRING[64]	"	Directory name
	Cancel	BOOL	FALSE	Cancel Conditions Established Flag.

External Variables	Variable	Data type	Constant	Comment
	_Card1Ready	BOOL	✓	SD Memory Card Ready Flag
	_Card1Protect	BOOL	✓	SD Memory Card Write Protected Flag
	_Card1Err	BOOL	✓	SD Memory Card Error Flag
	_Card1Deteriorated	BOOL	✓	SD Memory Card Life Warning Flag
	_Card1PowerFail	BOOL	---	SD Memory Card Power Interruption Flag
	_BackupBusy	BOOL	✓	Backup Function Busy Flag
	PTOut_Warning_SDLife	BOOL	---	Output to SD Memory Card life warning lamp
	PTOut_Warning_Pwr-Fail_onBackup	BOOL	---	Output to SD Memory Card power interrupted lamp
	PTOut_Done	BOOL	---	Output to backup normal end lamp
	PTOut_Cancel	BOOL	---	Output to backup canceled lamp
	PTOut_Error	BOOL	---	Output to backup error end lamp
	PTIn_Check_Backup	BOOL	---	Input from lamps OFF button
	PTIn_Cancel	BOOL	---	Input from cancel button

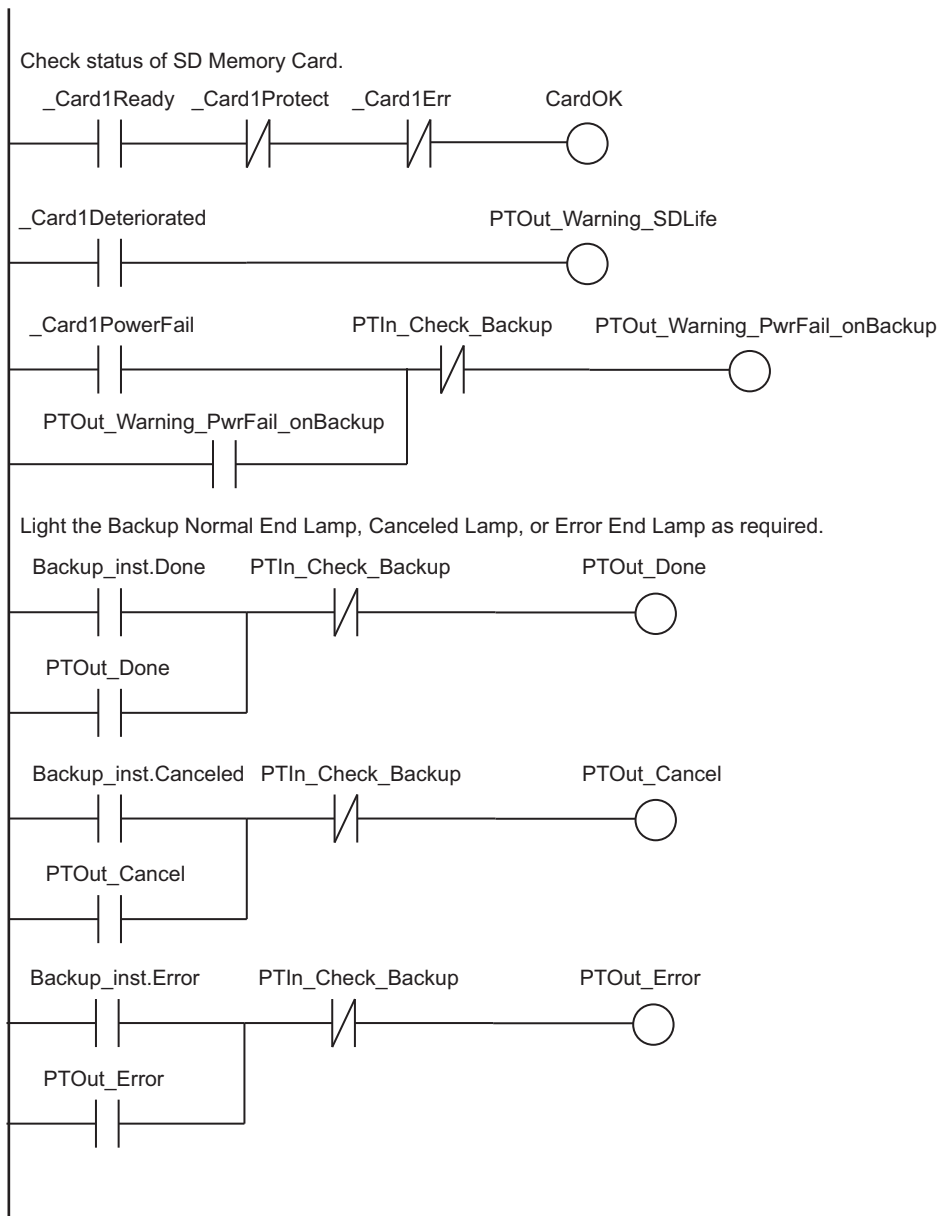

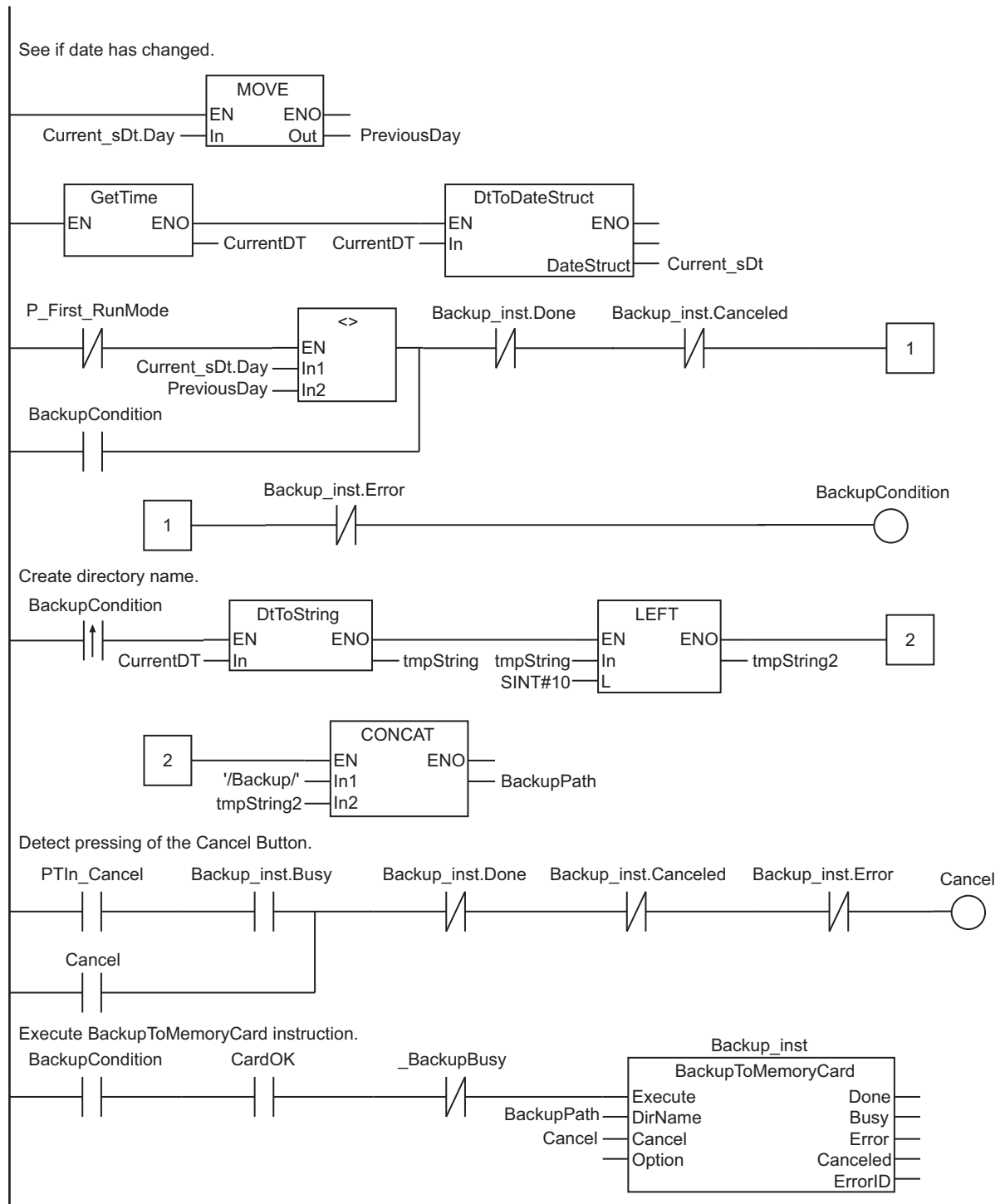

ST

Internal Variables	Variable	Data type	Initial value	Comment
	CardOK	BOOL	FALSE	SD Memory Card Normal Flag
	Backup_inst	BackupToMemory-Card		Instance of Backup-ToMemoryCard instruction
	PreviousDay	USINT	0	Date of previous task period
	CurrentDT	DATE_AND_TIME	ST#1970-01-01-00:00:00.000000000	Current date and time
	Current_sDt	_sDT	(Year:=0, Month:=0, Day:=0, Hour:=0, Min:=0, Sec:=0, NSec:=0)	The current date and time separated into the year, month, day, hour, minutes, seconds, and nanoseconds.
	BackupCondition	BOOL	FALSE	Backup Condition Established Flag
	tmpString	STRING[256]	"	Temporary text string used when creating directory name
	tmpString2	STRING[256]	"	Temporary text string used when creating directory name
	BackupPath	STRING[64]	"	Directory name
	Cancel	BOOL	FALSE	Cancel Conditions Established Flag
	RS1	RS		Instance 1 of Reset-Priority Keep instruction
	RS2	RS		Instance 2 of Reset-Priority Keep instruction
	RS3	RS		Instance 3 of Reset-Priority Keep instruction
	RS4	RS		Instance 4 of Reset-Priority Keep instruction
	RS5	RS		Instance 5 of Reset-Priority Keep instruction
	RS6	RS		Instance 6 of Reset-Priority Keep instruction

External Variables	Variable	Data type	Constant	Comment
	_Card1Ready	BOOL	✓	SD Memory Card Ready Flag
	_Card1Protect	BOOL	✓	SD Memory Card Write Protected Flag
	_Card1Err	BOOL	✓	SD Memory Card Error Flag
	_Card1Deteriorated	BOOL	✓	SD Memory Card Life Warning Flag
	_Card1PowerFail	BOOL	---	SD Memory Card Power Interruption Flag
	_BackupBusy	BOOL	✓	Backup Function Busy Flag
	PTOut_Warning_SDLife	BOOL	---	Output to SD Memory Card life warning lamp
	PTOut_Warning_Pwr-Fail_onBackup	BOOL	---	Output to SD Memory Card power interrupted lamp
	PTOut_Done	BOOL	---	Output to backup normal end lamp
	PTOut_Cancel	BOOL	---	Output to backup canceled lamp
	PTOut_Error	BOOL	---	Output to backup error end lamp
	PTIn_Check_Backup	BOOL	---	Input from lamps OFF button
	PTIn_Cancel	BOOL	---	Input from cancel button

```

// Check status of SD Memory Card.
CardOK := _Card1Ready OR NOT(_Card1Protect) OR NOT(_Card1Err);
PTOut_Warning_SDCardLife := _Card1Deteriorated;
RS1(Set := _Card1PowerFail, Reset1 := PTIn_Check_Backup,
Q1=>PTOut_Warning_PwrFail_onBackup);

// Light the Backup Normal End Lamp, Canceled Lamp, or Error End Lamp as
required.
RS2(Set := Backup_inst.Done,
Reset1 := PTIn_Check_Backup,
Q1 => PTOut_Done);
RS3(Set := Backup_inst.Canceled,
Reset1 := PTIn_Check_Backup,
Q1 => PTOut_Cancel);
RS4(Set := Backup_inst.Error,
Reset1 := PTIn_Check_Backup,
Q1 => PTOut_Error);

// See if date has changed.
PreviousDay := Current_sDT.Day;
CurrentDT:=GetTime();
DtToDateStruct(In := CurrentDT,DateStruct=>Current_sDT);
RS5(Set := ( NOT (P_First_RunMode) & (Current_sDT.Day<>PreviousDay) ,
Reset1 := (Backup_inst.Done OR Backup_inst.Canceled OR Backup_inst.Error) ,
Q1 => BackupCondition);

// Create directory name.
IF(BackupCondition) THEN
BackupPath := CONCAT('/Backup/', Left(In:= DtToString(CurrentDT),
L:=SINT#10));
END_IF;

// Detect pressing of the Cancel Button.
RS6(Set := (PTIn_Cancel &Backup_inst.Busy),
Reset1 := (Backup_inst.Done OR Backup_inst.Canceled OR Backup_inst.Error),
Q1 => Cancel);

```

```
// Execute BackupToMemoryCard instruction.  
Backup_inst(Execute := (BackupCondition & CardOK & NOT (_BackupBusy)),  
            DirName := BackupPath,  
            Cancel := Cancel);
```

Time Stamp Instructions

Instruction	Name	Page
NX_DOutTimeStamp	Write Digital Output with Specified Time Stamp	2-1434
NX_AryDOutTimeStamp	Write Digital Output Array with Specified Time Stamp	2-1440

NX_DOutTimeStamp

The NX_DOutTimeStamp instruction writes a value to the output bit of a Digital Output Unit that supports time stamp refreshing.

Instruction	Name	FB/ FUN	Graphic expression	ST expression
NX_DOutTime-Stamp	Write Digital Output with Specified Time Stamp	FB		NX_DOutTimeStamp_instance(Enable, SetDOut, SetTimeStamp, SyncOutTime, DOut, TimeStamp);

Variables

Name	Meaning	I/O	Description	Valid range	Unit	Default
Enable	Enable	Input	TRUE: Value of <i>SetDOut</i> is output. FALSE: Output changes to FALSE when <i>Enable</i> changes to FALSE.	Depends on data type.	---	FALSE
SetDOut	Output value		Output value			
SetTime-Stamp	Specified time stamp		Time to output value			
SyncOut Time	Time stamp of synchronous output		The <i>Time Stamp</i> of <i>Synchronous Output</i> device variable of the EtherCAT Coupler Unit or an NX Unit on the CPU Unit		ns	(*)
DOut	DOut Unit output bit	In-out	The <i>Output Bit</i> ** device variable of the Digital Output Unit that supports time stamp refreshing	Depends on data type.	---	---
TimeStamp	Time stamp		The <i>Output Bit</i> ** <i>Time Stamp</i> device variable of the Digital Output Unit that supports time stamp refreshing			

* If you omit an input parameter, the default value is not applied. A building error will occur.

	Boolean	Bit strings					Integers							Real numbers		Times, durations, dates, and text strings				
	BOOL	BYTE	WORD	DWORD	LWORD	USINT	UINT	UDINT	ULINT	SINT	INT	DINT	LINT	REAL	LREAL	TIME	DATE	TOD	DT	STRING
Enable	OK																			
SetDOut	OK																			
SetTime-Stamp								OK												
SyncOut Time								OK												
DOut	OK																			
TimeStamp								OK												

Function

When the value of *Enable* is TRUE, the NX_DOutTimeStamp instruction writes output value *SetDOut* to the output bit of a Digital Output Unit that supports time stamp refreshing at the specified time. When *Enable* changes to FALSE, the value of the output bit changes to FALSE from the next task period.

The error between the specified time and the output time is $\pm 1 \mu\text{s}$ max.

SyncOutTime (Time stamp of synchronous output) is based on the clock information in the EtherCAT Coupler Unit or NX Unit connected to the NX bus on the CPU Unit under which the Digital Output Unit that supports time stamp refreshing is connected. Specify the *Time Stamp of Synchronous Output* device variable of the EtherCAT Coupler Unit or NX Unit connected to the NX bus on the CPU Unit under which the Digital Output Unit is connected.

However, you must add 0x200A:02 (Time Stamp of Synchronous Output) to the I/O entries for the EtherCAT Coupler Unit.

Set the DOut Unit output bit *DOut* to the *Output Bit *** device variable that is assigned to the output bit of the Digital Output Unit that supports time stamp refreshing.

Set time stamp *TimeStamp* to the *Output Bit ** Time Stamp* device variable that is assigned to the output bit time stamp of the Digital Output Unit that supports time stamp refreshing.

Specifying the Output Time

Use the following procedure to specify the output time.

- 1** Get the device variable that is assigned to the clock information that is to serve as the reference time for the Unit bit.
- 2** Calculate the difference between the obtained clock information and the time to write the data to the output bit in nanoseconds and add it to the device variable from step 1.
- 3** Pass the results of adding the time difference to specified time stamp *SetTimeStamp* in the NX_DOutTimeStamp instruction.

For details, refer to the sample programming that is provided for this instruction.

Precautions for Correct Use

- You can execute this instruction only for a Digital Output Unit that supports time stamp refreshing. However, an error will not occur even if you execute this instruction when no Digital Output Unit that supports time stamp refreshing is connected.
- If an EtherCAT communications error occurs or if the task period is exceeded, the writing may not occur at the specified time. In that case, the value is output in the next task period or later.
- If the device variables that are used with this instruction are used with other instructions in the same or a different program, perform exclusive control processing.
- Set *SyncOutTime* to the *Time Stamp of Synchronous Output* device variable of the EtherCAT Coupler Unit or NX Unit connected to the NX bus on the CPU Unit under which the Digital Output Unit that supports time stamp refreshing is connected. However, an error will not occur even if another variable is specified.
- Set *DOut* and *TimeStamp* to the device variables of the Digital Output Unit that supports time stamp refreshing where the bit value is to be output. However, an error will not occur even if other variables are specified.
- Set *DOut* and *TimeStamp* to the device variables for the same channel of the same Unit. However, an error will not occur even if other variables are specified.
- If a previous time is specified for *SetTimeStamp*, the bit value is written in the next task period. In that case, the value of *TimeStamp* is 0.



Version Information

A CPU Unit with unit version 1.06 or later and Sysmac Studio version 1.07 or higher are required to use this instruction.

Sample Programming

In this sample, 10 ms after the value of input bit 00 of a Digital Input Unit that supports time stamp refreshing changes to TRUE, output bit 00 of a Digital Output Unit that supports time stamp refreshing changes to TRUE.

It is assumed that the value of input bit 00 is TRUE for longer than the I/O refresh period of the NX bus. A change to TRUE in input bit 00 is used as the input trigger in this sample. If the value of input bit 00 is TRUE for less than the I/O refresh period of the NX bus, the change to TRUE in input bit 00 is sometimes not detected. To solve that problem, for example, you could change the programming to use a change in the time that input bit 00 changes as the input trigger. Refer to the *NX-series Digital I/O Units User's Manual* (Cat. No. W521) for sample programming that turns ON an output after a specified time period expires after a change in a sensor input.

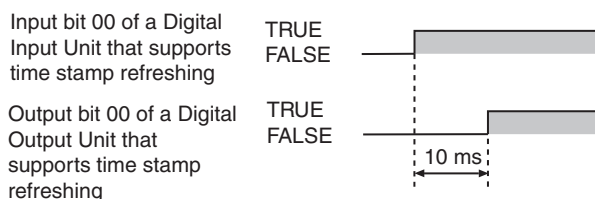

Network Configuration

The configuration of the network is given in the following table. A Slave Terminal with the following configuration is connected at EtherCAT node address 1. The device names that are given in the following table are used.

Unit number	Model number	Unit	Device name
0	NX-ECC201	EtherCAT Coupler Unit	E001
1	NX-ID3344	Digital Input Unit that supports time stamp refreshing	N1
2	NX-OD2154	Digital Output Unit that supports time stamp refreshing	N2

Unit Operation Settings

The Unit operation settings of the Digital Input Unit that supports time stamp refreshing are given in the following table.

Item	Set value	Meaning
Time Stamp (Trigger Setting): Input Bit 00 Trigger Setting	FALSE	Edge to read input changed time: Rising edge
Time Stamp (Mode Setting): Input Bit 00 Mode Setting	TRUE	Operating mode to read input changed time: One-shot (First changed time)

I/O Map

The following I/O map settings are used.

Position	Port	Description	R/W	Data type	Variable	Variable type
Node1	Time Stamp of Synchronous Output	Contains the time stamp for the timing of synchronous outputs from the connected NX Unit. (Unit: ns)	R	ULINT	E001_Time_Stamp_of_Synchronous_Output	Global variable
Unit1	Input Bit 00	Input bit 00	R	BOOL	N1_Input_Bit_00	Global variable
Unit1	Input Bit 00 Time Stamp	Input changed time for input bit 00	R	ULINT	N1_Input_Bit_00_Time_Stamp	Global variable
Unit2	Output Bit 00 Time Stamp	Specified time for output bit 00	W	ULINT	N2_Output_Bit_00_Time_Stamp	Global variable
Unit2	Output Bit 00	Output bit 00	W	BOOL	N2_Output_Bit_00	Global variable

LD

Internal Variables	Variable	Data type	Initial value	Comment
	SetTimeStamp	ULINT	0	Specified time stamp
	SetDOut	BOOL	FALSE	Output value
	NX_DOutTimeStamp_instance	NX_DOutTimeStamp		

External Variables	Variable	Data type	Constant	Comment
	N1_Input_Bit_00	BOOL	---	Input bit 00
	N1_Input_Bit_00_Time_Stamp	ULINT	---	Input changed time for input bit 00
	E001_Time_Stamp_of_Synchronous_Output	ULINT	---	Time stamp for the timing of synchronous outputs from the connected NX Unit
	N2_Output_Bit_00	BOOL	---	Output bit 00
	N2_Output_Bit_00_Time_Stamp	ULINT	---	Specified time for output bit 00

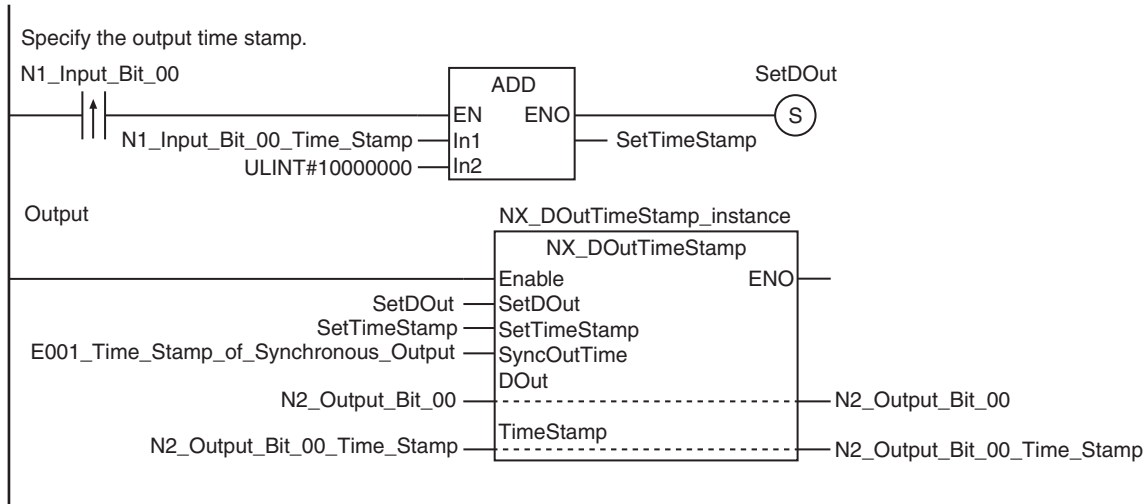

ST

Internal Variables	Variable	Data type	Initial value	Comment
	SetEN	BOOL	FALSE	Execution condition
	SetTimeStamp	ULINT	0	Specified time stamp
	SetDOut	BOOL	FALSE	Output value
	R_TRIG_instance	R_TRIG		
	NX_DOutTimeStamp_instance	NX_DOutTimeStamp		

External Variables	Variable	Data type	Constant	Comment
	N1_Input_Bit_00	BOOL	---	Input bit 00
	N1_Input_Bit_00_Time_Stamp	ULINT	---	Input changed time for input bit 00
	E001_Time_Stamp_of_Synchronous_Output	ULINT	---	Time stamp for the timing of synchronous outputs from the connected NX Unit
	N2_Output_Bit_00	BOOL	---	Output bit 00
	N2_Output_Bit_00_Time_Stamp	ULINT	---	Specified time for output bit 00

```

// Execution trigger input
R_TRIG_instance( N1_Input_Bit_00, SetEN);

// Specify the output time stamp.
IF ( SetEN = TRUE ) THEN
    SetDOut      := TRUE;
    SetTimeStamp := N1_Input_Bit_00_Time_Stamp + ULINT#10000000;
END_IF;

// Output
NX_DOutTimeStamp_instance(
    Enable      := TRUE,
    SetDOut     := SetDOut,
    SetTimeStamp := SetTimeStamp,
    SyncOutTime := E001_Time_Stamp_of_Synchronous_Output,
    DOut        := N2_Output_Bit_00,
    TimeStamp   := N2_Output_Bit_00_Time_Stamp);

```

NX_AryDOutTimeStamp

The NX_AryDOutTimeStamp instruction outputs pulses from a Digital Output Unit that supports time stamp refreshing.

Instruction	Name	FB/ FUN	Graphic expression	ST expression
NX_AryDOutTimeStamp	Write Digital Output Array with Specified Time Stamp	FB		NX_AryDOutTimeStamp_instance(Enable, SetDOut, SyncOutTime, DOut, TimeStamp);

Variables

Name	Meaning	I/O	Description	Valid range	Unit	Default
Enable	Enable	Input	TRUE: Output changes according to the setting of <i>SetDOut</i> . FALSE: Output changes to FALSE when <i>Enable</i> changes to FALSE.	Depends on data type.	---	FALSE
SyncOutTime	Time stamp of synchronous output		The <i>Time Stamp of Synchronous Output</i> device variable of the EtherCAT Coupler Unit or an NX Unit on the CPU Unit		ns	(*)
SetDOut	Output pulses	In-out	Output pulses	---	---	---
DOut	DOut Unit output bit		The <i>Output Bit **</i> device variable of the Digital Output Unit that supports time stamp refreshing	Depends on data type.		
TimeStamp	Time stamp		The <i>Output Bit ** Time Stamp</i> device variable of the Digital Output Unit that supports time stamp refreshing			

* If you omit the input parameter, the default value is not applied. A building error will occur.

	Boolean	Bit strings				Integers							Real numbers		Times, durations, dates, and text strings					
	BOOL	BYTE	WORD	DWORD	LWORD	USINT	UINT	UDINT	ULINT	SINT	INT	DINT	LINT	REAL	LREAL	TIME	DATE	TOD	DT	STRING
Enable	OK																			
SyncOutTime								OK												
SetDOut	Refer to <i>Function</i> for details on the structure <i>_sOUTPUT_REF</i> .																			
DOut	OK																			
TimeStamp								OK												

Function

When the value of *Enable* is TRUE, the NX_AryDOutTimeStamp instruction outputs the pulses set with output pulses *SetDOut* from a Digital Output Unit that supports time stamp refreshing at the specified times. When the value of *Enable* changes to FALSE, the NX_AryDOutTimeStamp instruction outputs FALSE to the Digital Output Unit that supports time stamp refreshing.

The error between the specified time and the output time is $\pm 1 \mu\text{s}$ max.

SyncOutTime (Time stamp of synchronous output) is based on the clock information in the EtherCAT Coupler Unit or NX Unit connected to the NX bus on the CPU Unit under which the Digital Output Unit that supports time stamp refreshing is connected. Specify the *Time Stamp of Synchronous Output* device variable of the EtherCAT Coupler Unit or NX Unit connected to the NX bus on the CPU Unit under which the Digital Output Unit is connected.

However, you must add 0x200A:02 (Time Stamp of Synchronous Output) to the I/O entries for the EtherCAT Coupler Unit.

Set the DOut Unit output bit *DOut* to the *Output Bit *** device variable that is assigned to the output bit of the Digital Output Unit that supports time stamp refreshing.

Set time stamp *TimeStamp* to the *Output Bit ** Time Stamp* device variable that is assigned to the output bit time stamp of the Digital Output Unit that supports time stamp refreshing.

Specifying the Output Time

Use the following procedure to specify the output time.

- 1** Get the device variable that is assigned to the clock information that is to serve as the reference time for the Unit bit.
- 2** Calculate the difference between the obtained clock information and the time to turn ON the output bit in nanoseconds and add it to the device variable from step 1.
- 3** Pass the results of adding the time difference to *SetDOut.OnTime[]* in the NX_AryDOutTimeStamp instruction.
- 4** In the same way as in step 2, calculate the difference between the obtained clock information and the time to turn OFF the output bit in nanoseconds and add it to the device variable from step 1.
- 5** Pass the results of adding the time difference to *SetDOut.OffTime[]* in the NX_AryDOutTimeStamp instruction.

Specifying the Output Pulses

The data type of output pulses *SetDOut* is structure *_sOUTPUT_REF*. The specifications are as follows:

Name	Meaning	Description	Data type	Valid range	Unit	Default
SetDOut	Output pulses	Output pulses	<i>_sOUTPUT_REF</i>	---	---	---
EnableOut	Output enable	Output enable flag TRUE: Enable <i>OnTime</i> and <i>OffTime</i> settings. FALSE: Disable <i>OnTime</i> and <i>OffTime</i> settings.	BOOL	Depends on data type.	---	FALSE
OnTime[] array	ON times	Times at which to turn ON the output bit	ARRAY[0..15] OF ULINT		ns	0 for all elements
OffTime[] array	OFF times	Times at which to turn OFF the output bit	ARRAY[0..15] OF ULINT			

The ON times *OnTime[]* and OFF times *OffTime[]* arrays each have 16 elements. The values of the elements with the same element numbers in both arrays are the ON time and OFF time for one pulse. Therefore, you can specify up to 16 pulses. If the value of the same element in both arrays is 0, the values of all of the elements past them are disabled.

For example, the following figure shows the output operation for the following values of the elements of *OnTime[]* and *OffTime[]*. The times specified in the following table indicate the number of milliseconds after the reference time.

Name	Element numbers				
	0	1	2	3	4
OnTime[]	10 ms later	30 ms later	60 ms later	0	90 ms later
OffTime[]	20 ms later	35 ms later	80 ms later	0	100 ms later

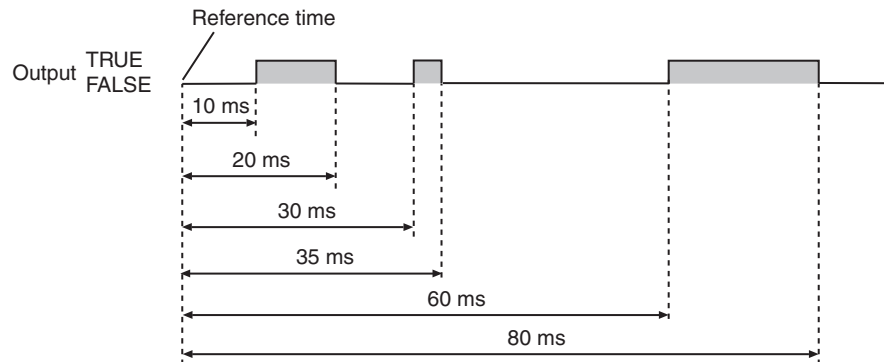

The values of the elements of *OnTime[]* and *OffTime[]* do not need to be in chronological order. For example, the output operation for the following values of the elements of *OnTime[]* and *OffTime[]* would be the same as the one shown above.

Name	Element numbers				
	0	1	2	3	4
OnTime[]	30 ms later	60 ms later	10 ms later	0	90 ms later
OffTime[]	35 ms later	80 ms later	20 ms later	0	100 ms later

● **EnableOut (Output Enable)**

Output enable *EnableOut* enables the settings in *OnTime[]* and *OffTime[]*. If the value of *EnableOut* is FALSE, the output value is FALSE regardless of the values in *OnTime[]* and *OffTime[]*.

You can change the value of *EnableOut* during execution of the instruction.

When the value of *EnableOut* changes to FALSE, the output value changes to FALSE.

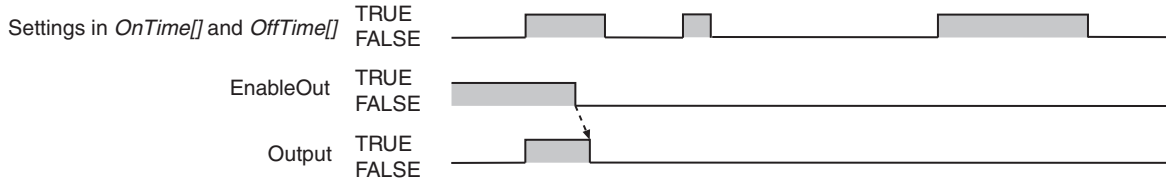

When the value of *EnableOut* changes to TRUE, the values in *OnTime[]* and *OffTime[]* are enabled.

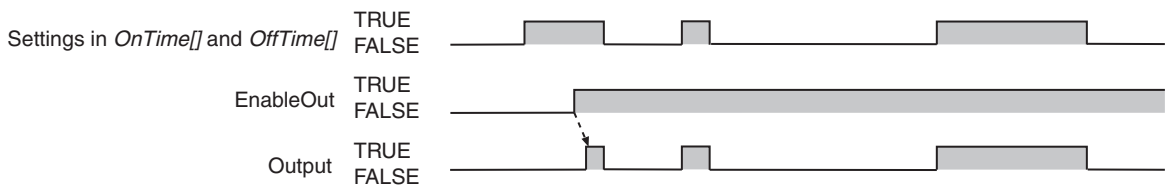

● **Minimum Output Pulse Width**

To output pulses with a time accuracy of 1 μs, set each of the interval between *OnTime[]* and *OffTime[]* to at least twice the task period. If the interval is less than two task periods, the pulse will be delayed from the specified ON/OFF time by one task period when the pulse is not output as specified.

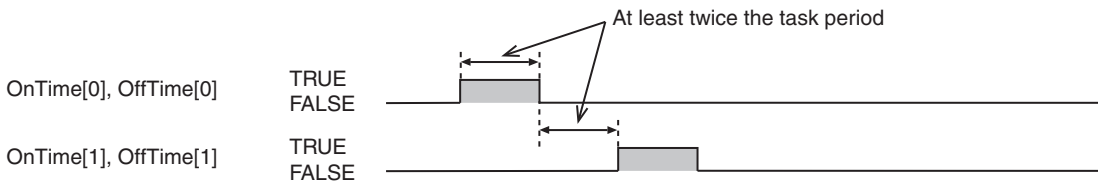

Refer to the following description for details on the operation.

● **Setting the Same Value for the Same Elements of *OnTime[]* and *OffTime[]***

If you set the same value for the same elements of *OnTime[]* and *OffTime[]*, the output will remain FALSE. Therefore, the following figure shows the output operation for the following values of the elements of the two arrays.

Name	Element numbers		
	0	1	2
<i>OnTime[]</i>	10 ms later	30 ms later	0
<i>OffTime[]</i>	20 ms later	30 ms later	0

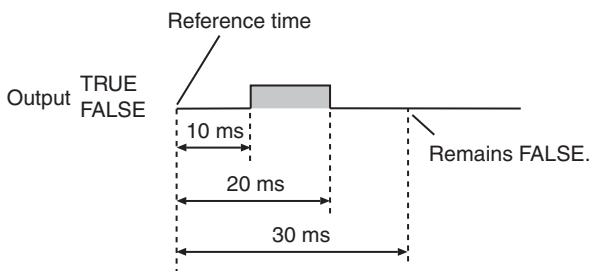

● **When Value in *OnTime[]* Is Larger Than Value in *OffTime[]* for the Same Element**

If the value in *OnTime[]* is larger than value in *OffTime[]* for the same element, the output value will change to FALSE first and then change to TRUE.

Also, if the lowest value of the elements of *OnTime[]* is larger than the lowest value of the elements of *OffTime[]*, the output value will change to TRUE immediately after the instruction is executed. Also, if the highest value of the elements of *OnTime[]* is larger than the highest value of the elements of *OffTime[]*, the output value will remain TRUE after the instruction is executed.

Therefore, the following figure shows the output operation for the following values of the elements of the two arrays.

Name	Element numbers		
	0	1	2
OnTime[]	20 ms later	35 ms later	0
OffTime[]	10 ms later	30 ms later	0

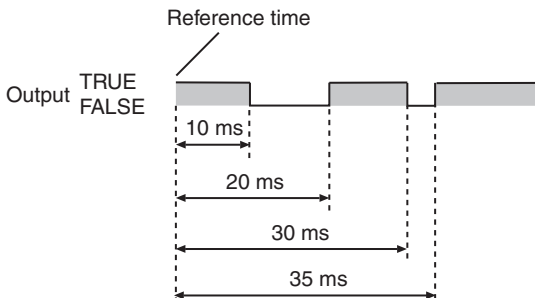

● **When Value of One Element in *OnTime[]* and *OffTime[]* Is 0**

If the value of the element in *OnTime[]* or *OffTime[]* is 0, the value of the output will change to TRUE or FALSE immediately after execution of the instruction.

If the only the value of the element in *OnTime[]* is 0, the value of the output will change to TRUE immediately after execution of the instruction. Therefore, the following figure shows the output operation for the following values of the elements of the two arrays.

Name	Element numbers		
	0	1	2
OnTime[]	0	30 ms later	0
OffTime[]	20 ms later	35 ms later	0

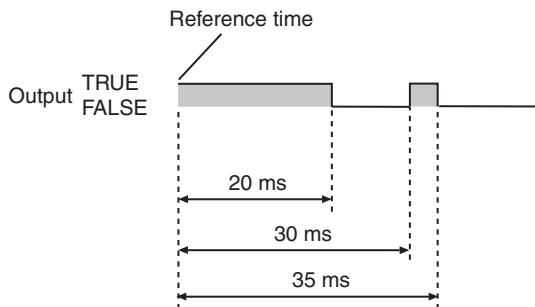

If the only the value of the element in *OffTime[]* is 0, the value of the output will change to FALSE immediately after execution of the instruction. Therefore, the following figure shows the output operation for the following values of the elements of the two arrays.

Name	Element numbers		
	0	1	2
OnTime[]	10 ms later	35 ms later	0
OffTime[]	0	30 ms later	0

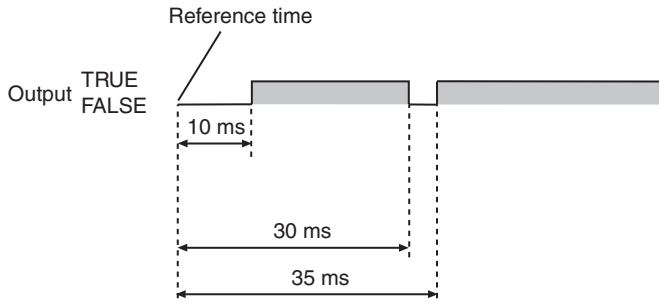

● **When, in the Same Task Period, the Output Value Is Consecutively Set to TRUE and FALSE**

If the output value is consecutively set to TRUE and FALSE in the same task period, the value of the output will not change.

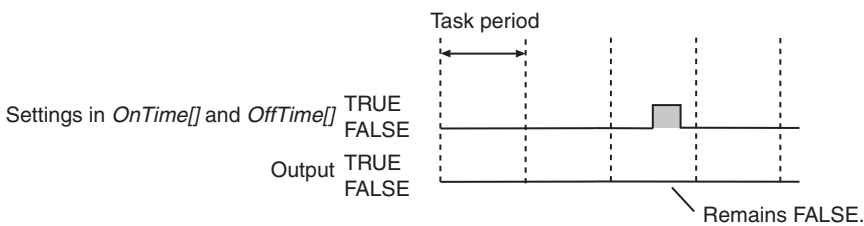

● **Changing the Values in *OnTime[]* or *OffTime[]* While the Instruction Is Enabled**

You can change the values in *OnTime[]* and *OffTime[]* while the instruction is enabled. The changes are valid the next time the instruction is executed.

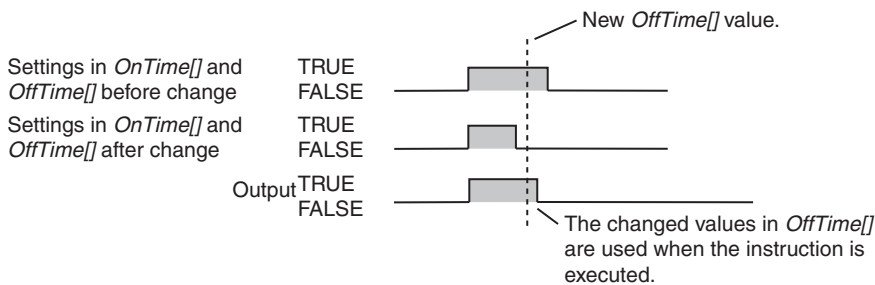

● **Overlapping TRUE Settings for an Output Value**

If TRUE settings for an output value overlap, an error will not occur and the output value will remain TRUE. The same logic applies when the FALSE settings for an output value overlap. Therefore, the following figure shows the output operation for the following values of the elements of the two arrays.

Name	Element numbers		
	0	1	2
<i>OnTime[]</i>	10 ms later	20 ms later	0
<i>OffTime[]</i>	30 ms later	40 ms later	0

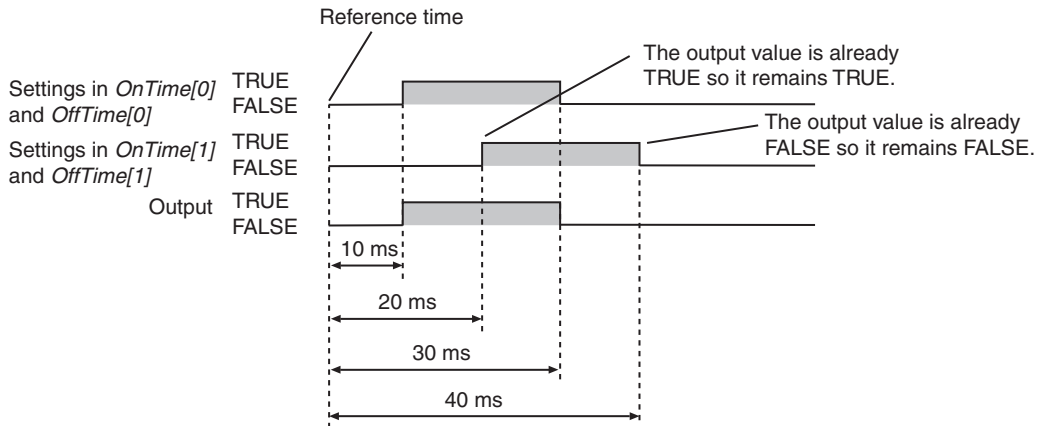

● **Simultaneous TRUE and FALSE Settings for an Output Value**

If there are TRUE and FALSE settings at the same time for an output value, an error will not occur and the setting for the element in *OnTime[]* and *OffTime[]* with the lower element number is given priority. Therefore, the following figure shows the output operation for the following values of the elements of the two arrays.

Name	Element numbers		
	0	1	2
<i>OnTime[]</i>	10 ms later	20 ms later	0
<i>OffTime[]</i>	20 ms later	30 ms later	0

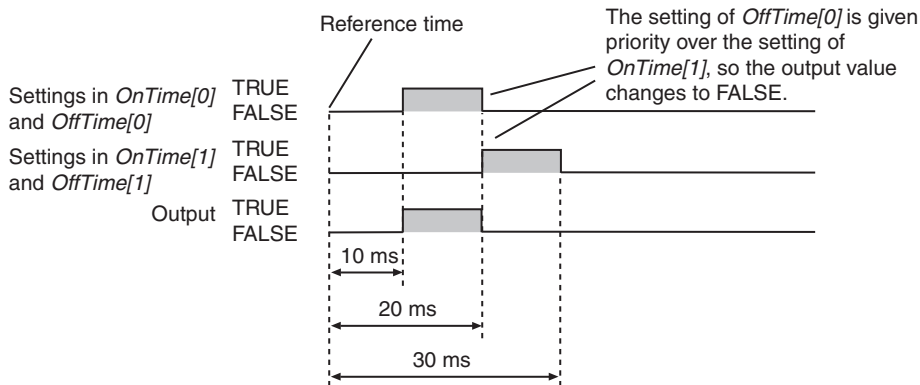

Additional Information

This instruction is used with the MC_DigitalCamSwitch instruction. Refer to the *NJ/NX-series Motion Control Instructions Reference Manual* (Cat. No. W508) for the detailed specifications of the MC_DigitalCamSwitch instruction.

Precautions for Correct Use

- You can execute this instruction only for a Digital Output Unit that supports time stamp refreshing. However, an error will not occur even if you execute this instruction when no Digital Output Unit that supports time stamp refreshing is connected.
- If an EtherCAT communications error occurs or if the task period is exceeded, the output may not occur at the specified time. In that case, the value is output in the next task period or later.
- If the device variables that are used with this instruction are used with other instructions in the same or a different program, perform exclusive control processing.
- Set *SyncOutTime* to the *Time Stamp of Synchronous Output* device variable of the EtherCAT Coupler Unit or NX Unit connected to the NX bus on the CPU Unit under which the Digital Output Unit that supports time stamp refreshing is connected. However, an error will not occur even if other variables are specified.

- Set *DOut* and *Timestamp* to the device variables of the Digital Output Unit that supports time stamp refreshing where the bit value is to be output. However, an error will not occur even if other variables are specified.
- Set *DOut* and *Timestamp* to the device variables for the same channel of the same Unit. However, an error will not occur even if other variables are specified.



Version Information

A CPU Unit with unit version 1.06 or later and Sysmac Studio version 1.07 or higher are required to use this instruction.

Sample Programming

For sample programming, refer to the section on the MC_DigitalCamSwitch instruction in the *NJ/NX-series Motion Control Instructions Reference Manual* (Cat. No. W508).

Other Instructions

Instruction	Name	Page
ReadNbit_**	N-bit Read Group	2-1450
WriteNbit_**	N-bit Write Group	2-1452
ChkRange	Check Subrange Variable	2-1454
GetMyTaskStatus	Read Current Task Status	2-1456
GetMyTaskInterval	Read Current Task Period	2-1459
Task_IsActive	Determine Task Status	2-1462
Lock and Unlock	Lock Tasks/Unlock Tasks	2-1464
ActEventTask	Activate Event Task	2-1471
Get**Clk	Get Clock Pulse Group	2-1477
Get**Cnt	Get Incrementing Free-running Counter Group	2-1478

ReadNbit_**

The ReadNbit_** instructions read zero or more bits from a bit string.

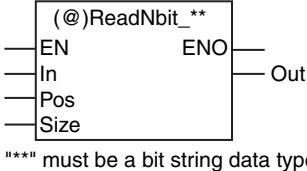
Instruction	Name	FB/FUN	Graphic expression	ST expression
ReadNbit_**	N-bit Read Group	FUN		Out:=ReadNbit_**(In, Pos, Size); "***" must be a bit string data type.

Variables

Name	Meaning	I/O	Description	Valid range	Unit	Default
In	Read source	Input	Bit string to read	Depends on data type.	---	0
Pos	Read position		Bit position to read	0 to No. of bits in <i>In</i> - 1		
Size	Read size		Number of bits to read	0 to No. of bits in <i>In</i>		
Out	Read result	Output	Read result	Depends on data type.	---	---

	Boolean	Bit strings					Integers							Real numbers	Times, durations, dates, and text strings					
	BOOL	BYTE	WORD	DWORD	LWORD	USINT	UINT	UDINT	ULINT	SINT	INT	DINT	LINT	REAL	LREAL	TIME	DATE	TOD	DT	STRING
In		OK	OK	OK	OK															
Pos						OK														
Size						OK														
Out	Must be same data type as <i>In</i>																			

Function

A ReadNbit_** instruction reads the values of the upper *Size* bits from read position *Pos* in source bit string *In*. It assigns the values to read result *Out*.

The name of the instruction is determined by the data types of *In* and *Out*. For example, if *In* and *Out* are the WORD data type, the instruction is ReadNbit_WORD.

The following example shows the ReadNbit_BYTE instruction when *In* is BYTE#16#89, *Pos* is USINT#2 and *Size* is USINT#4.

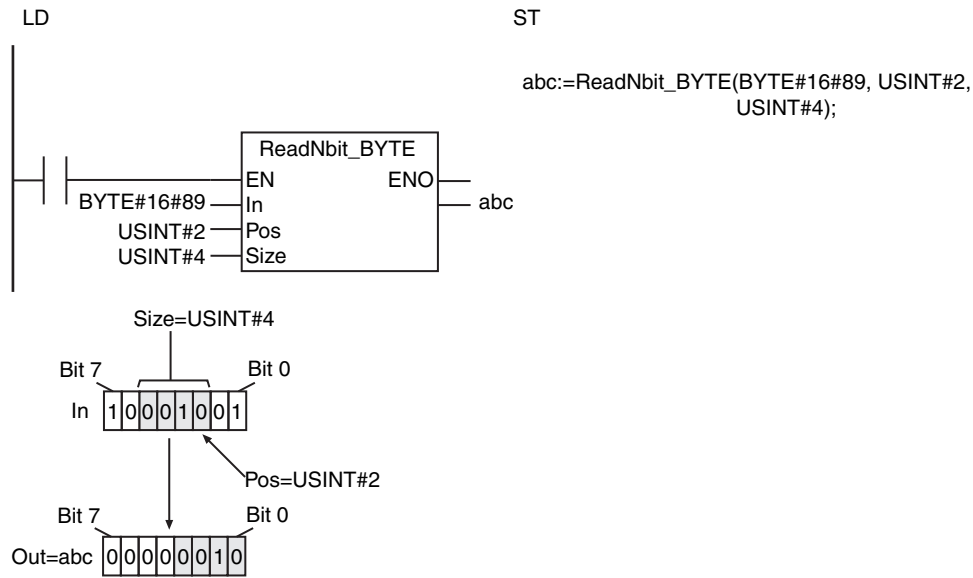

Additional Information

Use a WriteNbit_** instruction to write zero or more bits to a bit string.

Precautions for Correct Use

- The data types of *In* and *Out* must be the same.
- If the value of *Size* is 0, the value of *Out* is 16#0.
- An error occurs in the following cases. *ENO* will be FALSE, and *Out* will not change.
 - The value of *Size* is outside of the valid range.
 - The value of *Pos* is outside of the valid range.
 - The bit string in *In* does not have enough bits for the number of bits specified by *Size* from the position specified by *Pos*.

WriteNbit_**

The WriteNbit_** instructions write zero or more bits to a bit string.

Instruction	Name	FB/FUN	Graphic expression	ST expression
WriteNbit_**	N-bit Write Group	FUN		WriteNbit_**(In, Pos, Size, InOut); "***" must be a bit string data type.

Variables

Name	Meaning	I/O	Description	Valid range	Unit	Default
In	Read source	Input	Bit string from which to read bits to write to <i>InOut</i>	Depends on data type.	---	0
Pos	Write position		Bit position to which to write	0 to No. of bits in <i>InOut</i> -1		
Size	Write size		Number of bits to write	0 to No. of bits in <i>In</i>		
InOut	Write target	In-out	Write result	Depends on data type.	---	---
Out	Return value	Output	Always TRUE	TRUE only	---	---

	Boolean	Bit strings				Integers							Real numbers	Times, durations, dates, and text strings						
	BOOL	BYTE	WORD	DWORD	LWORD	USINT	UINT	UDINT	ULINT	SINT	INT	DINT	LINT	REAL	LREAL	TIME	DATE	TOD	DT	STRING
In		OK	OK	OK	OK															
Pos						OK														
Size						OK														
InOut	Must be same data type as <i>In</i>																			
Out	OK																			

Function

A WriteNbit_** instruction first reads the lower *Size* bits from read source *In*. Then it writes the values that it read to write position *Pos* in write target *InOut*.

The name of the instruction is determined by the data types of *In* and *Out*. For example, if *In* and *Out* are the WORD data type, the instruction is WriteNbit_WORD.

ChkRange

The ChkRange instruction determines if the value of a variable is within the valid range of the range type specification.

Instruction	Name	FB/FUN	Graphic expression	ST expression
ChkRange	Check Subrange Variable	FUN		Out:=ChkRange(In, Val);

Variables

Name	Meaning	I/O	Description	Valid range	Unit	Default
In	Variable to check	Input	Variable to check	Depends on data type.	---	*
Val	Range specification variable		Range specification variable	Depends on the range specification.		
Out	Check result	Output	Check result	Depends on data type.	---	---

* If you omit the input parameter, the default value is not applied. A building error will occur.

	Boolean	Bit strings					Integers						Real numbers	Times, durations, dates, and text strings						
	BOOL	BYTE	WORD	DWORD	LWORD	USINT	UINT	UDINT	ULINT	SINT	INT	DINT	LINT	REAL	LREAL	TIME	DATE	TOD	DT	STRING
In						OK	OK	OK	OK	OK	OK	OK								
Val	The basic data type that is the basis for the range specification must be the same as <i>In</i> .																			
Out	OK																			

Function

The ChkRange instruction determines if the value of variable to check *In* is within the valid range of the range specification variable *Val*. If the value is within the valid range, check result *Out* is TRUE. If the value is not within the valid range, check result *Out* is FALSE.

Additional Information

You can define the range type specification for integer variables (USINT, UINT, UDINT, ULINT, SINT, INT, DINT, and LINT).

Precautions for Correct Use

- If *In* is not a range specification variable, the value of *Out* changes to TRUE.
- If this instruction is used in a ladder diagram, the value of *Out* changes to FALSE if an error occurs in the previous instruction on the rung.

Sample Programming

Here, the result of addition *i* is checked to see if it is within the valid range (10 to 99) of the range specification variable *x*. If it is not within the valid range, the value of variable *Correct* is assigned to variable *x*.

LD

Variable	Data type	Initial value
i	INT	0
abc	INT	0
def	INT	0
x	INT(10..99)	10
Correct	INT	0

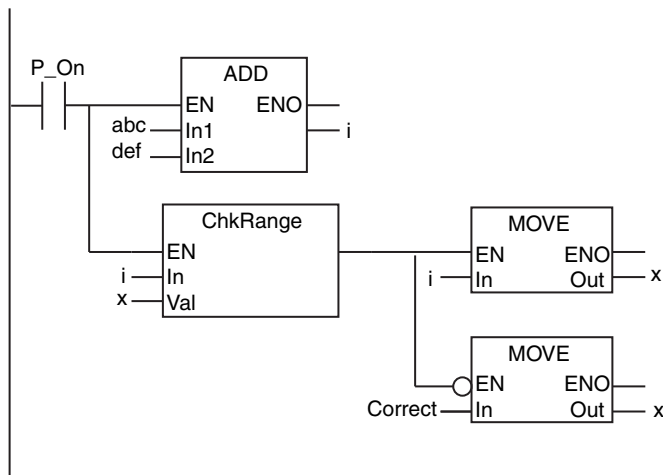

ST

Variable	Data type	Initial value
i	INT	0
abc	INT	0
def	INT	0
Chk	BOOL	FALSE
x	INT(10..99)	10
Correct	INT	0

```

i := abc+def;
Chk:=ChkRange(i, x); // Check subrange variable.

IF (Chk=TRUE) THEN
    x := i; // Assign i to x if value of i is in range.
ELSE
    x := Correct; // Assign Correct to x if value of i is out of range.
END_IF;

```

GetMyTaskStatus

The GetMyTaskStatus reads the status of the current task.

Instruction	Name	FB/FUN	Graphic expression	ST expression
GetMyTaskStatus	Read Current Task Status	FUN		GetMyTaskStatus(LastExecTime, MaxExecTime, MinExecTime, ExecCount, Exceeded, ExceedCount);

Variables

Name	Meaning	I/O	Description	Valid range	Unit	Default
Out	Return value	Output	Always TRUE	TRUE only	---	---
LastExec Time	Last task execution time		Last task execution time of the current task	Depends on data type.*	ns	
MaxExec Time	Maximum task execution time		Maximum task execution time of the current task			
MinExec Time	Minimum task execution time		Minimum task execution time of the current task			
ExecCount	Task execution count		Number of task executions of the current task	Depends on data type.	---	
Exceeded	Task period exceeded flag		TRUE: The last execution of the current task was not completed within the task period. FALSE: The last execution of the current task was completed within the task period.			
Exceed-Count	Task period exceeded count	The number of times the current task has exceeded the task period.				

* Negative numbers are excluded.

	Boolean	Bit strings					Integers							Real numbers		Times, durations, dates, and text strings				
	BOOL	BYTE	WORD	DWORD	LWORD	USINT	UINT	UDINT	ULINT	SINT	INT	DINT	LINT	REAL	LREAL	TIME	DATE	TOD	DT	STRING
Out						OK														
LastExec Time																OK				
MaxExec Time																OK				
MinExec Time																OK				

	Boolean	Bit strings					Integers							Real numbers		Times, durations, dates, and text strings				
	BOOL	BYTE	WORD	DWORD	LWORD	USINT	UINT	UDINT	ULINT	SINT	INT	DINT	LINT	REAL	LREAL	TIME	DATE	TOD	DT	STRING
ExecCount								OK												
Exceeded	OK																			
Exceed-Count								OK												

Function

The GetMyTaskStatus reads the status of the current task. The task status includes the last task execution time *LastExecTime*, maximum task execution time *MaxExecTime*, minimum task execution time *MinExecTime*, task execution count *ExecCount*, task period exceeded flag *Exceeded*, and task period exceeded count *ExceedCount*.

Additional Information

MaxExecTime, *MinExecTime*, *ExecCount*, and *ExceedCount* are reset at the following times.

- When operation is started
- When a reset operation is executed from the Task Execution Time Monitor of the Sysmac Studio.

Precautions for Correct Use

- When the value of *ExecCount* or *ExceedCount* exceeds the maximum value of UDINT data (4,294,967,295), it returns to 0.
- Return value *Out* is not used when the instruction is used in ST.

Sample Programming

In this sample, the GetMyTaskStatus reads the status of the current task. If the previous task execution time exceeds 400 μ s (400000 ns), the value of the *Warning* variable changes to TRUE.

LD

Variable	Data type	Initial value	Comment
ExecTime_t	TIME	T#0s	Previous task execution time (TIME data)
ExecTime_ns	INT	0	Previous task execution time (nanoseconds LINT data)
Warning	BOOL	FALSE	Warning

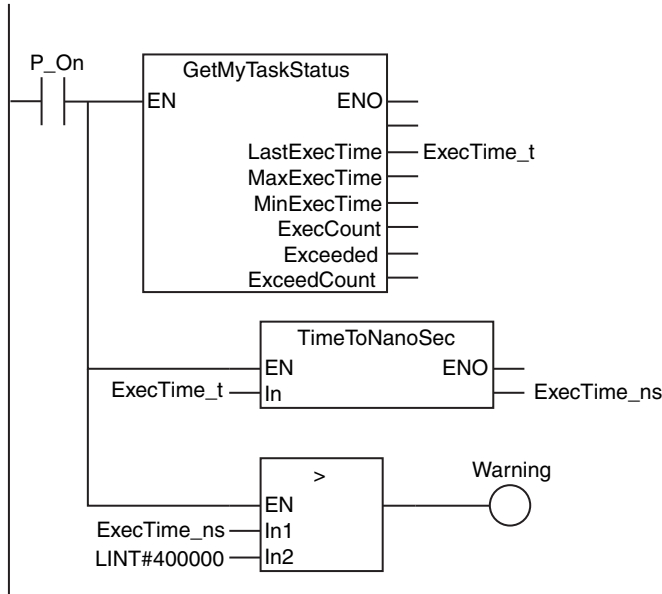

ST

Variable	Data type	Initial value	Comment
ExecTime_t	TIME	T#0s	Previous task execution time (TIME data)
ExecTime_ns	LINT	0	Previous task execution time (nanoseconds LINT data)
Warning	BOOL	FALSE	Warning

```

GetMyTaskStatus>LastExecTime=>ExecTime_t); // Get previous task period.
ExecTime_ns:=TimeToNanoSec(ExecTime_t); // Convert previous task period from TIME data to nanoseconds.
IF (ExecTime_ns>DINT#400000) THEN // If previous task period exceeds 400,000 ns...
    Warning:=TRUE; // Assign TRUE to Warning variable.
ELSE
    Warning:=FALSE;
END_IF;
    
```

GetMyTaskInterval

The GetMyTaskInterval instruction reads the task period of the current task.

Instruction	Name	FB/FUN	Graphic expression	ST expression
GetMyTaskInterval	Read Current Task Period	FUN		Out:=GetMyTaskInterval();

Variables

Name	Meaning	I/O	Description	Valid range	Unit	Default
Out	Task period	Output	Task period of current task	Depends on data type.*1	ms	---

*1 Negative numbers are excluded.

	Boolean	Bit strings					Integers							Real numbers	Times, durations, dates, and text strings					
	BOOL	BYTE	WORD	DWORD	LWORD	USINT	UINT	UDINT	ULINT	SINT	INT	DINT	LINT	REAL	LREAL	TIME	DATE	TOD	DT	STRING
Out																OK				

Function

The GetMyTaskInterval instruction reads the task period of the current task and stores it in task period *Out* if the task that executes the instruction is the primary periodic task or a periodic task.

If an event task executes the instruction, the value of *Out* will be T#0s.

The following figure shows a programming example. If the task period of the current task is 1 ms, the value of *abc* will be T#1ms.

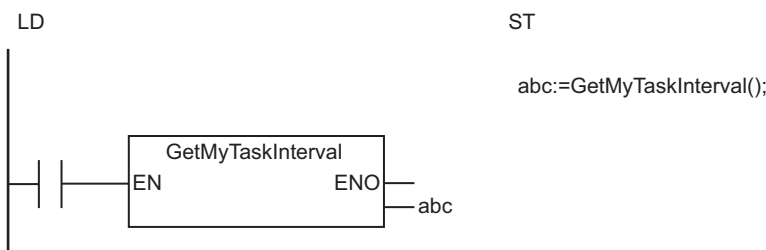



Version Information

A CPU Unit with unit version 1.08 or later and Sysmac Studio version 1.09 or higher are required to use this instruction.

Sample Programming

This example reads the task period of the current task when this program is first executed after operation starts. Then the task period that was read is converted from TIME data to LREAL data in milliseconds. This sample programming can be used, for example, to calculate the axis target position for each task period.

The following procedure is used to convert TIME data to LREAL data in milliseconds.

- 1** The GetMyTaskInterval instruction is used to read the task period as TIME data.
- 2** The TimeToNanoSec instruction is used to convert TIME data to LINT data in nanoseconds.
- 3** The LINT_TO_LREAL instruction is used to convert LINT data in nanoseconds to LREAL data in nanoseconds.
- 4** The DIV instruction is used to divide the result of step 3 by 1,000,000 to convert to milliseconds.

LD

Variable	Data type	Default	Comment
Intv_tm	TIME	T#0s	Task period as TIME data
Intv_ns	LINT	0	Task period as LINT data in nanoseconds
Intv	LREAL	0	Task period as LREAL data in milliseconds

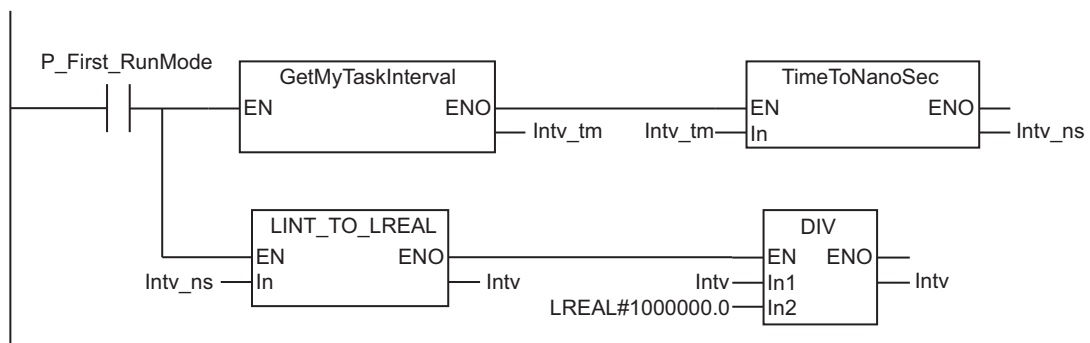

ST

Variable	Data type	Default	Comment
Intv	LREAL	0	Task period as LREAL data in milliseconds

```
IF P_First_RunMode = TRUE THEN
  Intv := LINT_TO_LREAL(TimeToNanoSec(GetMyTaskInterval()))/1000000;
END_IF;
```

Task_IsActive

The Task_IsActive instruction determines if the specified task is currently in execution.

Instruction	Name	FB/FUN	Graphic expression	ST expression
Task_IsActive	Determine Task Status	FUN		Out:=Task_IsActive(TaskName);

Variables

Name	Meaning	I/O	Description	Valid range	Unit	Default
TaskName	Task name	Input	Task name	64 bytes max. (63 single-byte alphanumeric characters plus the final NULL character)	---	"
Out	Judgement	Output	TRUE: Task is in execution or on standby. FALSE: Not active	Depends on data type.	---	---

	Boolean	Bit strings					Integers							Real numbers	Times, durations, dates, and text strings					
	BOOL	BYTE	WORD	DWORD	LWORD	USINT	UINT	UDINT	ULINT	SINT	INT	DINT	LINT	REAL	LREAL	TIME	DATE	TOD	DT	STRING
TaskName																				OK
Out	OK																			

Function

The Task_IsActive instruction determines if the task specified with *TaskName* is currently in execution or on standby. “On standby” means that a high-priority task was started after this task was started, so processing has been interrupted.

If it is being executed or on standby, the value of judgement *Out* is TRUE. If it is not being executed, the value of *Out* is FALSE.

Precautions for Correct Use

- You cannot use a variable to which a text string was assigned for *TaskName*. Directly specify a text string.
- If this instruction is used in a ladder diagram, the value of *Out* changes to FALSE if an error occurs in the previous instruction on the rung.
- An error occurs in the following case. The value of *Out* does not change.
 - The task specified with *TaskName* does not exist.

Sample Programming

In this sample, the instruction determines whether periodic task Tc2 is active when the value of variable A changes to TRUE. If it is active, the value of variable B changes to TRUE.

LD

Variable	Data type	Initial value	Comment
A	BOOL	FALSE	
B	BOOL	FALSE	
Tc2_Run	BOOL	FALSE	Task Tc2 execution status

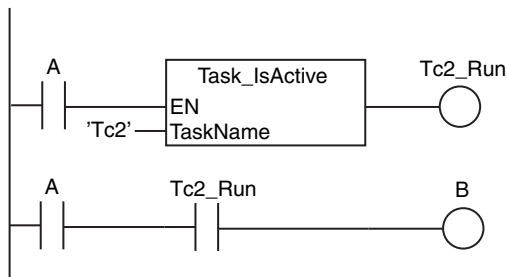

ST

Variable	Data type	Initial value	Comment
A	BOOL	FALSE	
B	BOOL	FALSE	
Tc2_Run	BOOL	FALSE	Task Tc2 execution status

```

IF (A=TRUE) THEN
  // Determine task status.
  Tc2_Run:=Task_IsActive('Tc2');
  // Make variable B TRUE if Tc2 is running.
  IF (Tc2_Run=TRUE) THEN
    B := TRUE;
  END_IF;
END_IF;

```

Lock and Unlock

Lock: Starts an exclusive lock between tasks. Execution of any other task with a lock region with the same lock number is disabled.

Unlock: Stops an exclusive lock between tasks.

Instruction	Name	FB/FUN	Graphic expression	ST expression
Lock	Lock Tasks	FUN		Lock(Index);
Unlock	Unlock Tasks	FUN		Unlock(Index);

Variables

Name	Meaning	I/O	Description	Valid range	Unit	Default
Index	Lock number	Input	Lock number	Depends on data type.	---	0
Out	Return value	Output	Always TRUE	TRUE only	---	---

	Boolean	Bit strings					Integers							Real numbers	Times, durations, dates, and text strings					
	BOOL	BYTE	WORD	DWORD	LWORD	USINT	UINT	UDINT	ULINT	SINT	INT	DINT	LINT	REAL	LREAL	TIME	DATE	TOD	DT	STRING
Index						OK														
Out	OK																			

Function

The Lock and Unlock instructions create lock regions. If a lock region in one task is being executed, the lock regions with the same lock number in other tasks are not executed. Specify the lock number with *Index*.

The following figure shows a programming example.

Both task T1 and task T2 contain a lock region with *Index* set to 1. If the Lock instruction in T2 is executed first, the lock region in T1 is not executed until the Unlock instruction is executed in T2.

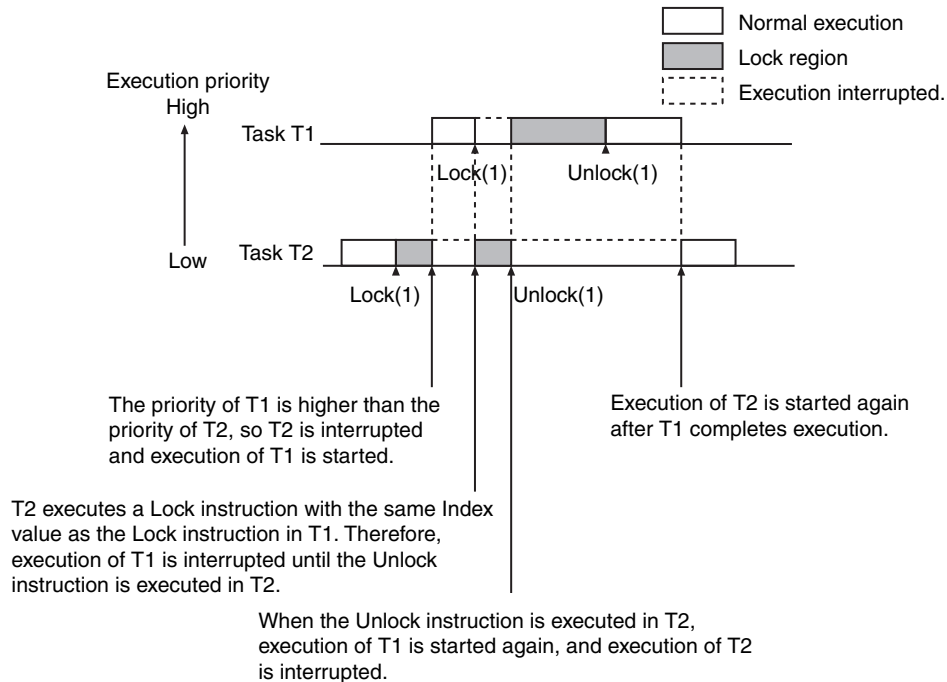

Lock regions with different values for *Index* do not affect each other.

Additional Information

- The Lock and Unlock instructions are used when the same data is read/written from more than one task. They are used to prevent other tasks from reading/writing the data while a certain task is reading/writing the data.
- As long as the *Index* values are different, more than one pair of Lock and Unlock instructions can be placed in the same POU. The instruction pairs can also be nested.

Precautions for Correct Use

- Do not make lock regions any longer than necessary. If the lock region is too long, the task execution period may be exceeded.
- Always use the Lock and Unlock instructions together as a set in the same section of the same POU.
- You can set a maximum of 16,777,215 lock regions at the same time.

- If Lock instructions are used in more than one task, a deadlock may occur if they are positioned poorly. A Task Execution Timeout Error will occur if there is a deadlock and a total stop is performed.

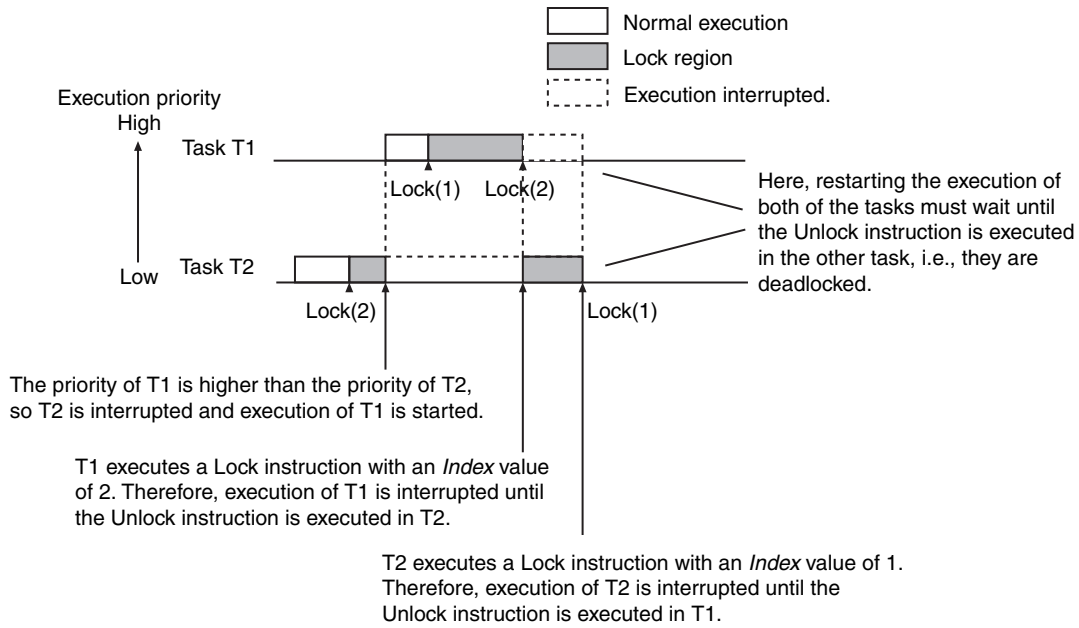

- An error occurs in the following case. The value of *Out* does not change.
 - There are more than 16,777,215 lock region at the same time.

Sample Programming

Here, program P1 in task T1 and program P2 in task T2 both access the same global variable *GTable1*. When the value of write request *WriteReq* changes to TRUE, P1 writes one record to record array *GTable1.Record[]* and increments *GTable1.Index*. When read request *ReadReq* changes to TRUE, P2 decrements *GTable1.Index* and reads one record from *GTable1.Record[]*. The Lock instruction is used so that reading and writing do not occur at the same time.

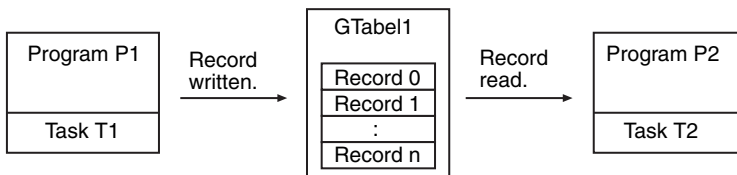

Definition of Global Variable *GTable*

Data type

Variable	Data type	Comment
USERTABLE	STRUCT	Record storage structure
Index	INT	Index
Record	ARRAY[0..99] OF LREAL	Record array

Global Variables

Variable	Data type	Initial value	Comment
GTable1	USERTABLE	(Index:=0,Record:=[100(0.0)])	Record storage structure

Program P1

LD

Internal Variables	Variable	Data type	Initial value	Comment
	WriteReq	BOOL	FALSE	Write request
	InDat	LREAL	0.0	Write data

External Variables	Variable	Data type	Comment
	GTable1	USERTABLE	Record storage structure

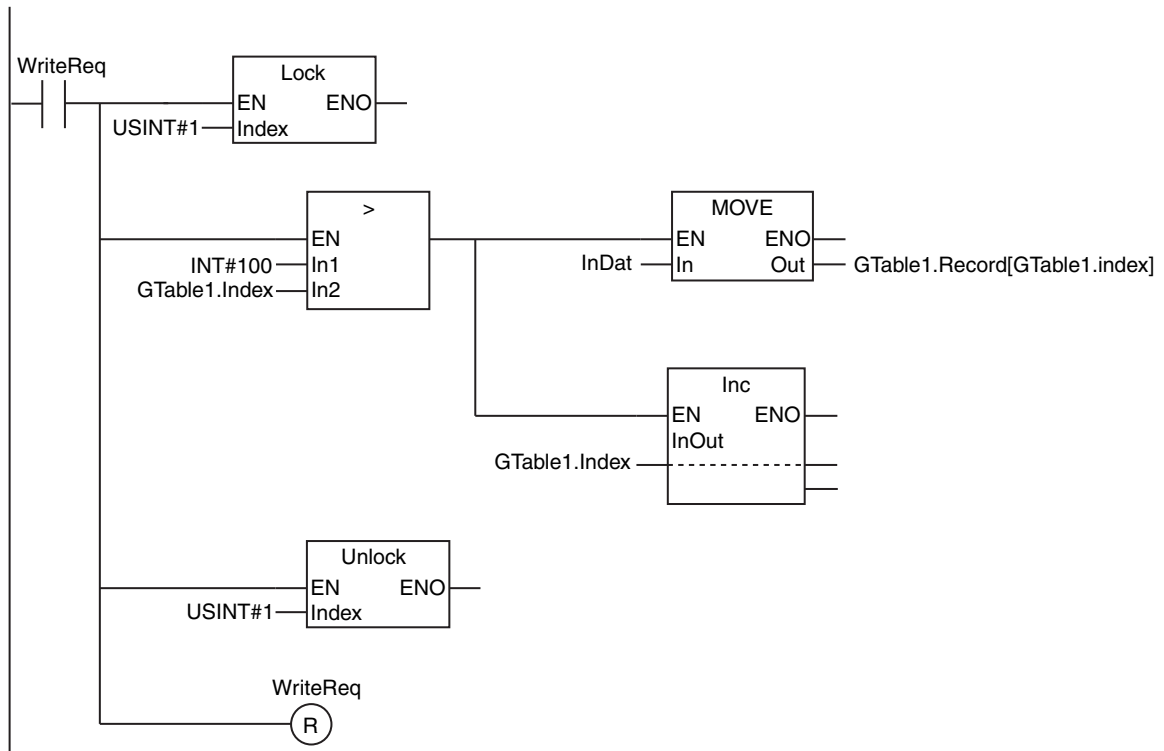

ST

Internal Variables	Variable	Data type	Initial value	Comment
	WriteReq	BOOL	FALSE	Write request
	InDat	LREAL	0.0	Write data

External Variables	Variable	Data type	Comment
	GTable1	USERTABLE	Record storage structure

```
// Detect write request.
IF (WriteReq=TRUE) THEN

    // Execute Lock instruction.
    Lock(USINT#1);

    IF (INT#100>GTable1.Index) THEN
        GTable1.Record[GTable1.Index] :=InDat;
        GTable1.Index                 :=GTable1.Index+INT#1;
    END_IF;

    // Execute Unlock instruction.
```

```
        Unlock(USINT#1);  
        WriteReq:=FALSE;  
  
END_IF;
```

Program P2

LD

Internal Variables	Variable	Data type	Initial value	Comment
	ReadReq	BOOL	FALSE	Read request
	OutDat	LREAL	0.0	Read data

External Variables	Variable	Data type	Comment
	GTable1	USERTABLE	Record storage structure

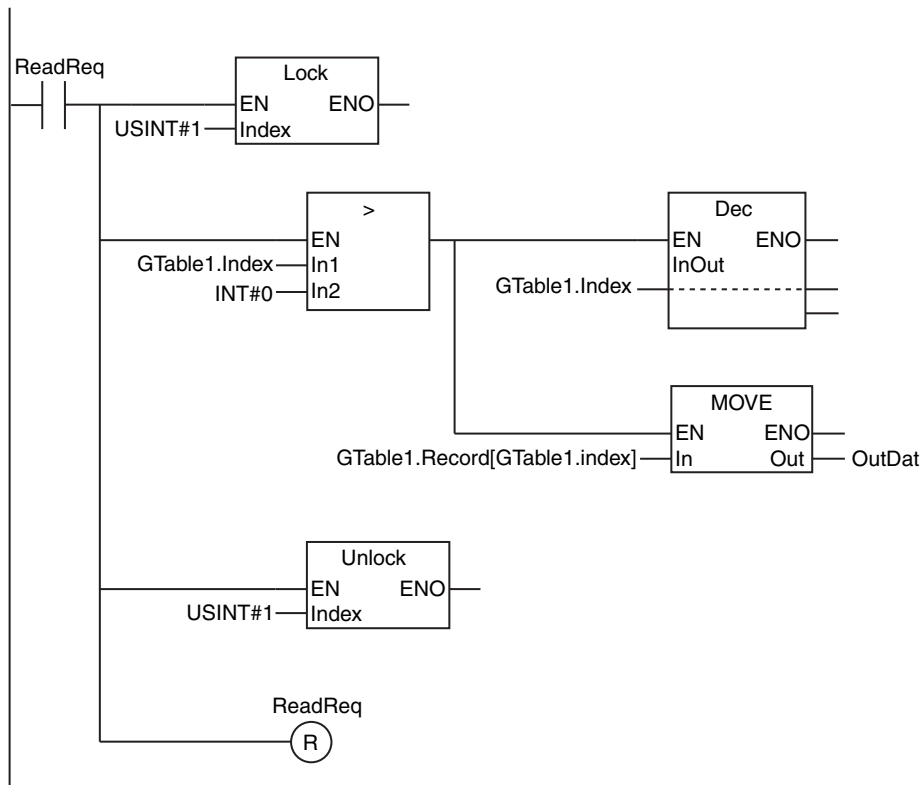

ST

Internal Variables	Variable	Data type	Initial value	Comment
	ReadReq	BOOL	FALSE	Read request
	OutDat	LREAL	0.0	Read data

External Variables	Variable	Data type	Comment
	GTable1	USERTABLE	Record storage structure

```
// Detect read request.
IF (ReadReq=TRUE) THEN

    // Execute Lock instruction.
    Lock (USINT#1);

    IF (GTable1.Index>INT#0) THEN
        GTable1.Index:=GTable1.Index-INT#1;
        OutDat      :=GTable1.Record[GTable1.Index];
    END_IF;

```

```
        // Execute Unlock instruction.  
        Unlock(USINT#1);  
        ReadReq:=FALSE;  
  
    END_IF;
```

ActEventTask

The ActEventTask instruction activates an event task.

Instruction	Name	FB/ FUN	Graphic expression	ST expression
ActEventTask	Activate Event Task	FUN		ActEventTask(TaskName);

Variables

Name	Meaning	I/O	Description	Valid range	Unit	Default
TaskName	Task name	Input	The name of the event task to activate	64 bytes max. (63 single-byte alphanumeric characters plus the final NULL character)	---	"
Out	Return value	Output	TRUE: The instruction was executed without any errors. FALSE: The instruction was not executed or an error occurred.	Depends on data type.	---	---

	Boolean	Bit strings					Integers						Real numbers	Times, durations, dates, and text strings						
	BOOL	BYTE	WORD	DWORD	LWORD	USINT	UINT	UDINT	ULINT	SINT	INT	DINT	LINT	REAL	LREAL	TIME	DATE	TOD	DT	STRING
TaskName																				OK
Out	OK																			

Function

The ActEventTask instruction activates the event task with task name *TaskName*. The event task operates according to its task execution priority.

If an event task is started that has an execution priority that is lower than the execution priority of the task in which this instruction was executed, the event task is executed after completion of the execution of the task in which this instruction was executed. For example, assume that the execution priority of event task T2 is lower than the execution priority of periodic task T1. If the ActEventTask instruction is executed for T2 in T1, the execution of T1 is completed before T2 is executed.

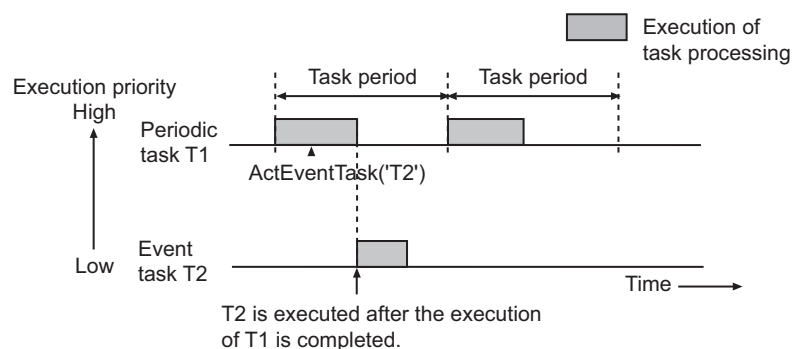

If an event task is started that has an execution priority that is higher than the execution priority of the task in which this instruction was executed, the execution of the task in which this instruction was executed is paused and the event task is executed. For example, assume that the execution priority of periodic task T2 is lower than the execution priority of event task T1. If the ActEventTask instruction is executed for T1 in T2, the execution of T2 is paused to execute T1.

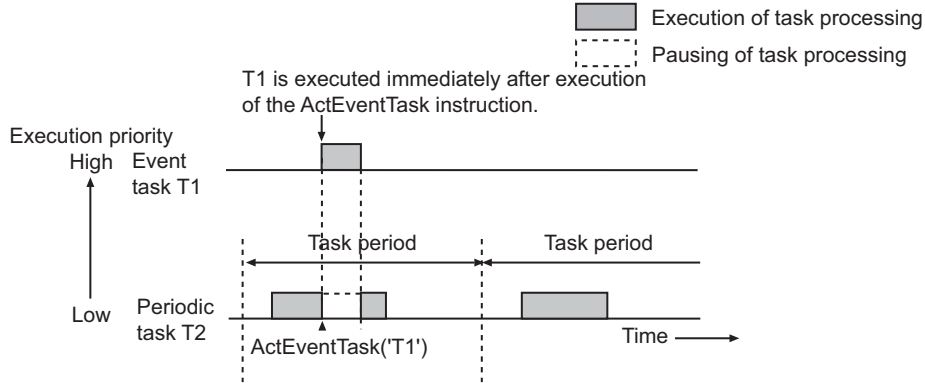

The following figure shows a programming example. When the value of variable *A* is TRUE, event task 'Te' is executed.

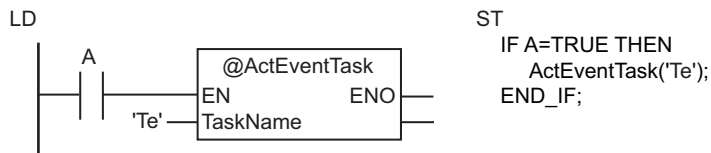

Assume that the program with these instructions is assigned to periodic task T1 and that the execution priority of Te is lower than that of T1. If this instruction is executed in T1, the execution of T1 is completed before Te is executed.

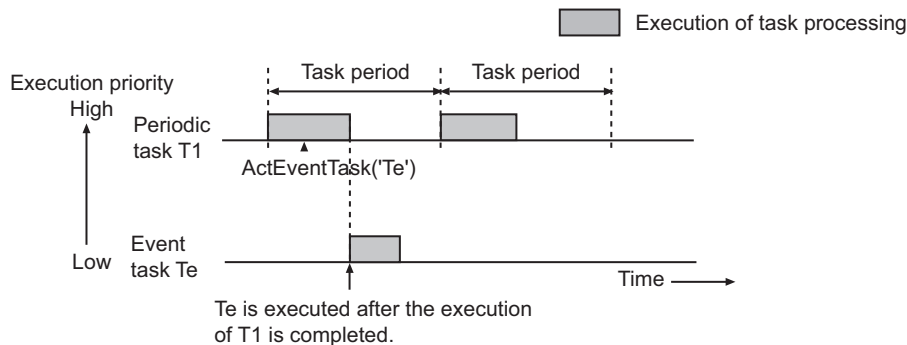

Related System-defined Variables

Name	Meaning	Data type	Description
_ ** _Active ^{*1}	Task Active Flag	BOOL	This variable indicates the execution status of the task. ^{*2} TRUE: Execution processing is in progress. FALSE: Stopped.

^{*1} The asterisks (**) are replaced with the task name.

^{*2} Refer to the *NJ/NX-series CPU Unit Software User's Manual* (Cat. No. W501) or *NY-series Industrial Panel PC / Industrial Box PC Software User's Manual* (Cat. No. W558) for details.

Additional Information

Operation of `_**_Active` System-defined Variable

- When this instruction is executed, the `_**_Active` system-defined variable for the specified event task will change to TRUE. It will change to FALSE when execution of the event task is completed. For example, assume that the execution priority of event task T2 is lower than the execution priority of periodic task T1. When the `ActEventTask` instruction is executed for T2 in T1, the system-defined variable `_T2_Active` will change as shown in the following figure.

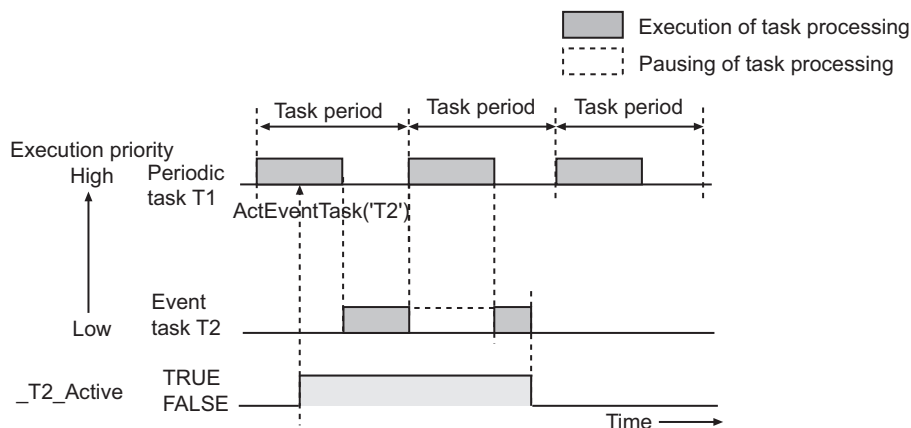

- The event task will not be executed even if this instruction is executed while the system-defined variable `_**_Active` for the event task is TRUE.

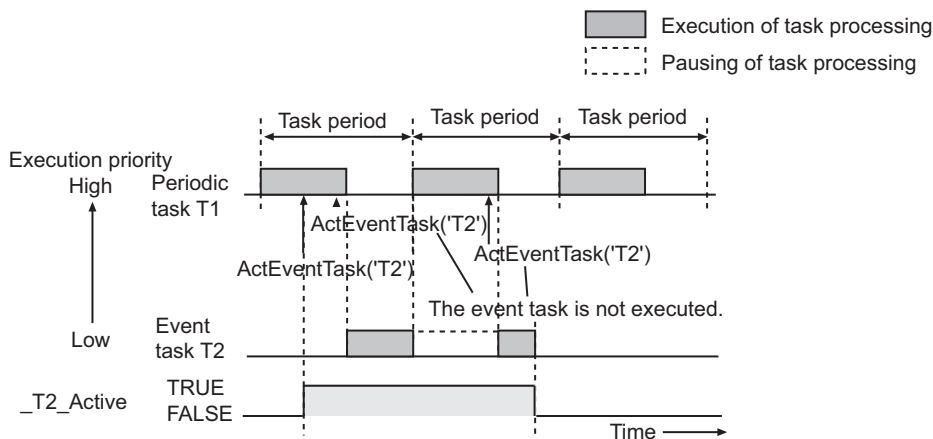

Executing an Event Task Only Once and Executing It Repeatedly

Use the following type of programming when you want to execute an event task only once when the value of a specified variable changes and when you want to execute an event task repeatedly as long as the variable has a specific value.

Example 1: Executing an Event Task Only Once When the Value of a Specified Variable Changes

If you use an upward differentiation instruction option for the instruction as shown below, event task 'Task1' will be executed only once when the value of BOOL variable `BoolVar` changes from FALSE to TRUE.

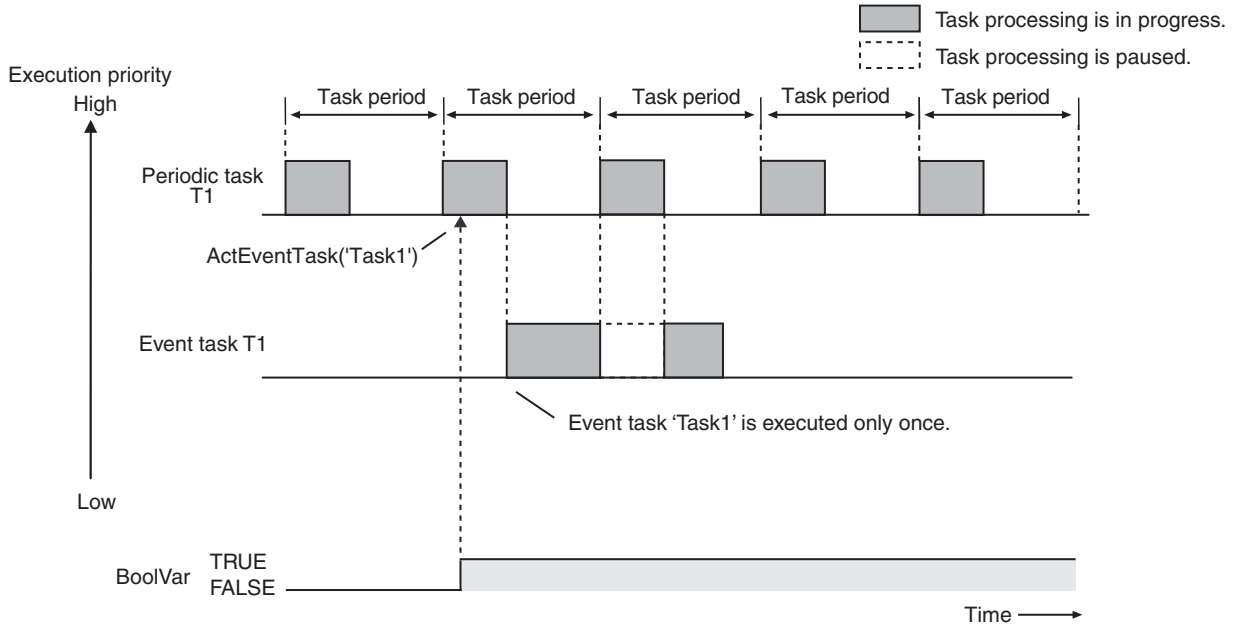
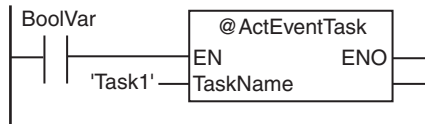

Example 2: Executing an Event Task Repeatedly as Long as a Variable Has a Specific Value

If you do not use an upward differentiation instruction option for the instruction as shown below, event task 'Task1' will be executed repeatedly as long as the value of BOOL variable *BoolVar* is TRUE. However, if this instruction is executed for Task1 while Task1 execution is in progress, it will be ignored.

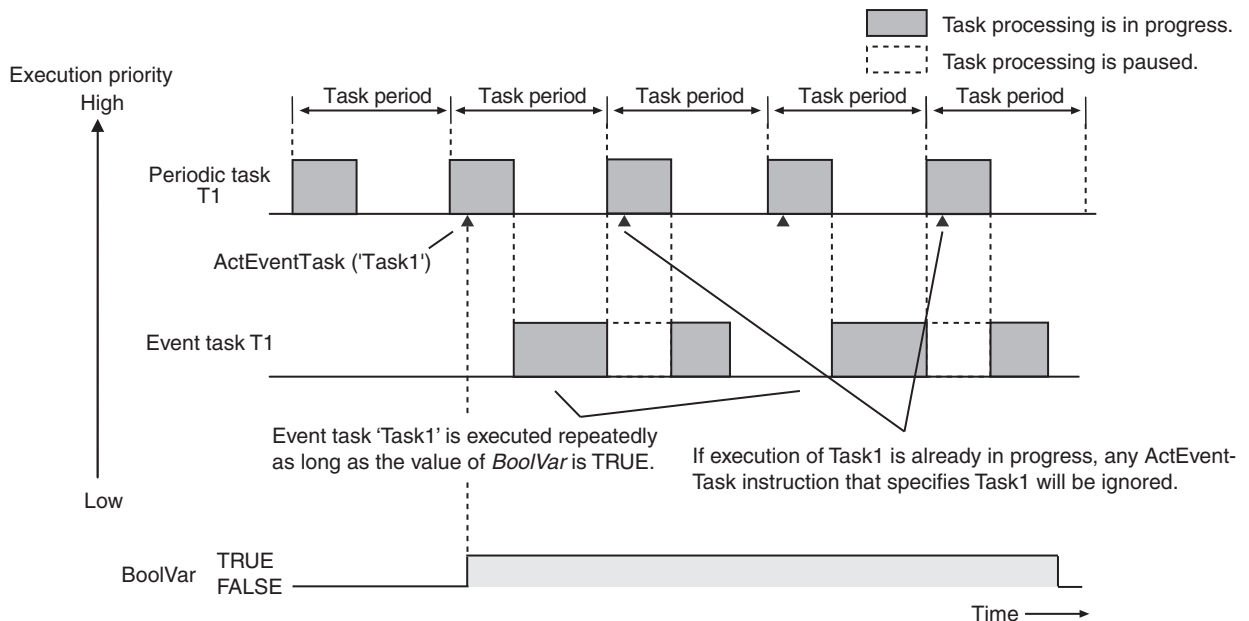
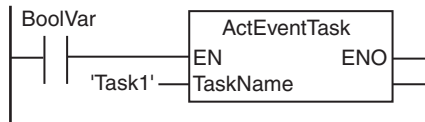

Precautions for Correct Use

- To reduce the instruction execution time, execute this instruction only when it is necessary to execute the event task. If the instruction is executed while the system-defined variable `__Active` is TRUE, processing time is required even if the event task is not executed.
- An error will occur if the event task that is specified with *TaskName* does not exist. *ENO* will be FALSE.



Version Information

A CPU Unit with unit version 1.03 or later and Sysmac Studio version 1.04 or higher are required to use this instruction.

Sample Programming

● Example of Executing an Event Task When the Value of a Variable Meets the Specified Condition

Event task 'Te' is executed only once when the value of variable *RcdNum* changes from less than the value of the variable *MaxRcdNum* to greater than or equal to the value of *MaxRcdNum*.

LD

Variable	Data type	Initial value
RcdNum	INT	0
MaxRcdNum	INT	100

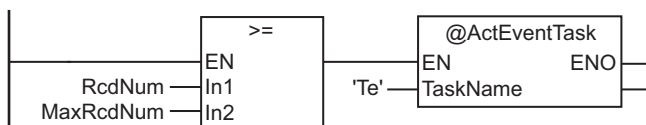

ST

Variable	Data type	Initial value
RcdNum	INT	0
MaxRcdNum	INT	100
met	BOOL	FALSE

```

IF (RcdNum>=MaxRcdNum) THEN
  IF (met=FALSE) THEN
    ActEventTask('Te');
    met:=TRUE;
  END_IF;
ELSE
  met:=FALSE;
END_IF;

```

● Example of Confirming Completion of Event Task before Proceeding

In this example, event task 'Task1' is executed each time the value of *Trigger* changes to TRUE. The Task_IsActive instruction is used to see when execution of Task 1 is completed.

LD

Name	Data type	Initial value	Comment
Trigger	BOOL	FALSE	Execution condition
Operating	BOOL	FALSE	Checking event task execution in progress
Active	BOOL	FALSE	Event task execution in progress

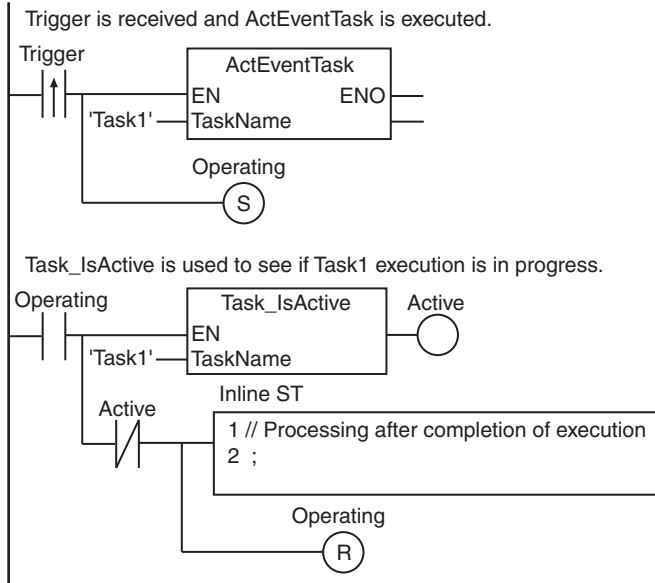

ST

Name	Data type	Initial value	Comment
Trigger	BOOL	FALSE	Execution condition
LastTrigger	BOOL	FALSE	Value of <i>Trigger</i> from previous task period
Operating	BOOL	FALSE	Checking event task execution in progress
Active	BOOL	FALSE	Event task execution in progress

```
// Start sequence when Trigger changes to TRUE.
IF ( (Trigger=TRUE) AND (LastTrigger=FALSE) ) THEN
    ActEventTask('Task1');          // Execute event task 'Task1'.
    Operating:=TRUE;
END_IF;
LastTrigger:=Trigger;

// See if Task1 execution is in progress.
IF (Operating=TRUE) THEN
    Active:=Task_IsActive('Task1');

    IF (Active=FALSE) THEN          // Task1 execution completed.
        Operating:=FALSE;
    END_IF;
END_IF;
```

Get**Clk

The Get**Clk instruction outputs a clock pulse at the specified cycle.

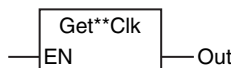
Instruction	Name	FB/FUN	Graphic expression	ST expression
Get**Clk	Get Clock Pulse Group	FUN	 <p>*** must be 100 us, 1 ms, 10 ms, 20 ms, 100 ms, 1 s, or 1 min.</p>	Out:=Get**Clk(); "***" must be 100 us, 1 ms, 10 ms, 20 ms, 100 ms, 1 s, or 1 min.

Variables

Name	Meaning	I/O	Description	Valid range	Unit	Default
Out	Clock pulse	Output	Clock pulse	Depends on data type.	---	---

	Boolean	Bit strings				Integers							Real numbers	Times, durations, dates, and text strings						
	BOOL	BYTE	WORD	DWORD	LWORD	USINT	UINT	UDINT	ULINT	SINT	INT	DINT	LINT	REAL	LREAL	TIME	DATE	TOD	DT	STRING
Out	OK																			

Function

The Get**Clk instruction outputs a clock pulse at the specified cycle.

The clock pulse period is 100 us, 1 ms, 10 ms, 20 ms, 100 ms, 1 s, or 1 min.

The name of the instruction is determined by the period of the clock pulse. For example, if the period of the clock pulse is 10 ms, the instruction name is Get10msClk.

The following example is for the Get1sClk instruction.

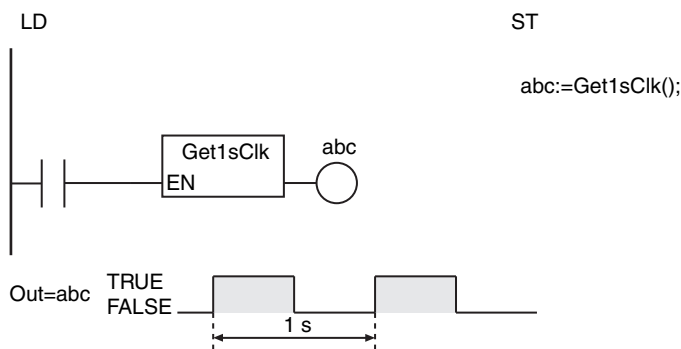

Precautions for Correct Use

- When the instruction is executed, the first value of *Out* may be TRUE or it may be FALSE.
- If this instruction is used in a ladder diagram, the value of *Out* changes to FALSE if an error occurs in the previous instruction on the rung.

Get**Cnt

The Get**Cnt instruction gets the values of free-running counters of the specified cycle.

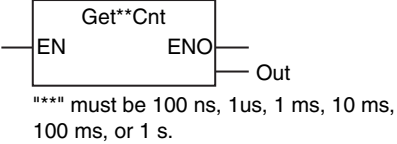
Instruction	Name	FB/FUN	Graphic expression	ST expression
Get**Cnt	Get Incrementing Free-running Counter Group	FUN		Out:=Get**Cnt(); "*** must be 100 ns, 1 us, 1 ms, 10 ms, 100 ms, or 1 s.

Variables

Name	Meaning	I/O	Description	Valid range	Unit	Default
Out	Count	Output	Value of free-running counter	Depends on data type.	---	---

	Boolean	Bit strings					Integers					Real numbers	Times, durations, dates, and text strings								
		BOOL	BYTE	WORD	DWORD	LWORD	USINT	UINT	UDINT	ULINT	SINT		INT	DINT	LINT	REAL	LREAL	TIME	DATE	TOD	DT
Out									OK												

Function

The Get**Cnt instruction gets the values of free-running counters of the specified cycle.

A free-running counter is a counter that is incremented at a specific period. *Out* is the current value of the count. The counter period is 100 ns, 1 us, 1 ms, 10 ms, 100 ms, or 1 s.

The name of the instruction is determined by counter period. For example, if the counter period is 10 ms, the instruction name is Get10msCnt.

The following example is for the Get1sCnt instruction.

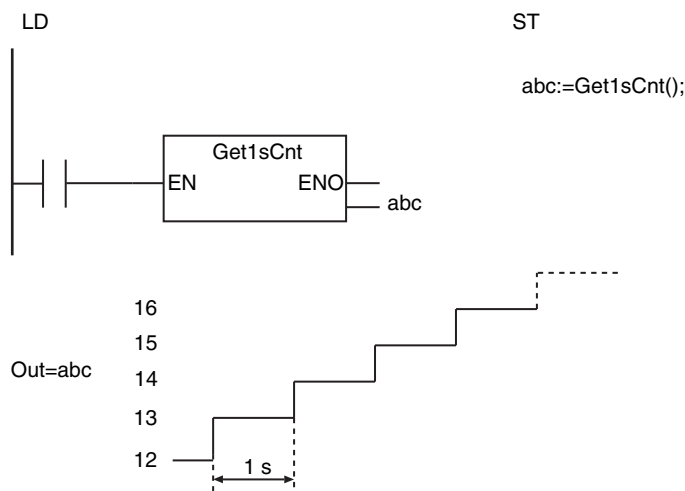

Precautions for Correct Use

- Free-running counters start counting as soon as the power supply is turned ON. When the count exceeds the valid range of ULINT data (18,446,744,073,709,551,615), it returns to 0 and counting continues.
- This instruction only gets the current value of the free-running counter. It does not reset the counter to 0.
- The first value of *Out* cannot be predicted. It will not necessarily start from 0.

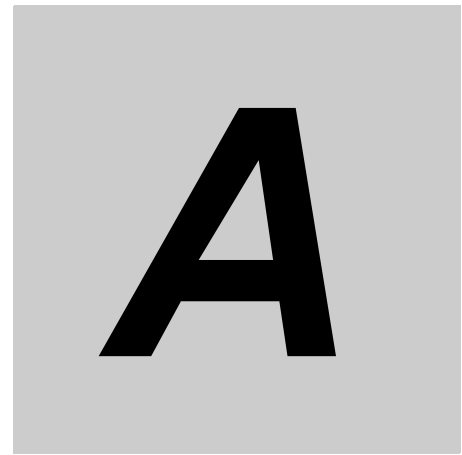

Appendices

A

A-1 Error Codes That You Can Check with ErrorID	A-2
A-2 Error Code Descriptions	A-21
A-3 Error Code Details	A-55
A-4 Instructions You Cannot Use in Event Tasks	A-212
A-5 Instructions Related to NX Message Communications Errors	A-214
A-6 SDO Abort Codes	A-215
A-7 Version Information	A-216

A-1 Error Codes That You Can Check with *ErrorID*

Error codes are assigned to the errors that can occur when instructions are executed. When you use instructions that have an error code output variable (*ErrorID*), you can use the error codes to program error processing.

The following table lists the instructions with *ErrorID* and the error codes that can occur for those instructions. Refer to *Error Code Details* on page A-55 for the meanings of the error codes.



Additional Information

You can check for errors for instructions that do not have *ErrorID* in the events in the event log.

Type	Instruction	Name	Error code	Error name
Analog Control Instructions	PIDAT	PID Control with Autotuning	16#0400	Input Value Out of Range
			16#0401	Input Mismatch
	PIDAT_HeatCool	Heating/Cooling PID with Autotuning	16#0400	Input Value Out of Range
			16#0401	Input Mismatch
	AC_StepProgram	Step Program	16#0400	Input Value Out of Range
	System Control Instructions	ResetPLCError	Reset PLC Controller Error	---
ResetCJBErro		Reset I/O Bus Error	16#0400	Input Value Out of Range
			16#040D	Illegal Unit Specified
ResetMCErro		Reset Motion Control Error	---	---
ResetECErro		Reset EtherCAT Error	16#041A	Multi-execution of Instructions
GetNXUnitError		Get NX Unit Error Status	16#0400	Input Value Out of Range
			16#041A	Multi-execution of Instructions
			16#2C00	NX Message Error
			16#2C02	NX Message Timeout
ResetUnit		Restart Unit	16#0400	Input Value Out of Range
			16#040D	Illegal Unit Specified
			16#040F	Unit Restart Failed
RestartNXUnit		Restart NX Unit	16#0400	Input Value Out of Range
			16#0419	Incorrect Data Type
			16#2C00	NX Message Error
			16#2C01	NX Message Resource Overflow
			16#2C02	NX Message Timeout
			16#2C05	NX Message EtherCAT Network Error
			16#2C06	External Restart Already Executed for Specified NX Units
16#2C07		Unapplicable Unit Specified for Instruction		

Type	Instruction	Name	Error code	Error name
System Control Instructions	NX_ChangeWriteMode	Change to NX Unit Write Mode	16#0400	Input Value Out of Range
			16#0419	Incorrect Data Type
			16#2C00	NX Message Error
			16#2C01	NX Message Resource Overflow
			16#2C02	NX Message Timeout
			16#2C05	NX Message EtherCAT Network Error
	NX_SaveParam	Save NX Unit Parameters	16#0400	Input Value Out of Range
			16#0419	Incorrect Data Type
			16#2C00	NX Message Error
			16#2C01	NX Message Resource Overflow
	NX_ReadTotalPowerOnTime	Read NX Unit Total Power ON Time	16#2C02	NX Message Timeout
			16#0400	Input Value Out of Range
			16#0419	Incorrect Data Type
			16#2C00	NX Message Error
			16#2C01	NX Message Resource Overflow
EtherCAT Communications Instructions	EC_CoESDOWrite	Write EtherCAT CoE SDO	16#2C08	Invalid Total Power ON Time Record
			16#0400	Input Value Out of Range
			16#1800	EtherCAT Communications Error
			16#1801	EtherCAT Slave Does Not Respond
			16#1802	EtherCAT Timeout
			16#1804	SDO Abort Error
	EC_CoESDORead	Read EtherCAT CoE SDO	16#1808	Communications Resource Overflow
			16#0400	Input Value Out of Range
			16#1800	EtherCAT Communications Error
			16#1801	EtherCAT Slave Does Not Respond
			16#1802	EtherCAT Timeout
			16#1803	Reception Buffer Overflow
EC_StartMon	Start EtherCAT Packet Monitor	16#1804	SDO Abort Error	
		16#1805	Saving Packet Monitor File	
		16#1807	Packet Monitoring Function in Operation	
EC_StopMon	Stop EtherCAT Packet Monitor	16#1808	Communications Resource Overflow	
		16#1806	Packet Monitoring Function Not Started	
			16#1808	Communications Resource Overflow

Type	Instruction	Name	Error code	Error name
EtherCAT Communications Instructions	EC_SaveMon	Save EtherCAT Packets	16#1805	Saving Packet Monitor File
			16#1807	Packet Monitoring Function in Operation
			16#1808	Communications Resource Overflow
	EC_CopyMon	Transfer EtherCAT Packets	16#0400	Input Value Out of Range
			16#1400	SD Memory Card Access Failure
			16#1401	SD Memory Card Write-protected
			16#1402	SD Memory Card Insufficient Capacity
			16#1403	File Does Not Exist
			16#1404	Too Many Files/ Directories
			16#1405	File Already in Use
			16#140A	Write Access Denied
			16#140B	Too Many Files Open
			16#140D	File or Directory Name Is Too Long
			16#140E	SD Memory Card Access Failed
			16#1808	Communications Resource Overflow
	EC_DisconnectSlave	Disconnect EtherCAT Slave	16#1800	EtherCAT Communications Error
			16#1801	EtherCAT Slave Does Not Respond
			16#1808	Communications Resource Overflow
	EC_ConnectSlave	Connect EtherCAT Slave	16#1800	EtherCAT Communications Error
			16#1801	EtherCAT Slave Does Not Respond
			16#1808	Communications Resource Overflow
	EC_ChangeEnableSetting	Enable/Disable EtherCAT Slave	16#1800	EtherCAT Communications Error
			16#1801	EtherCAT Slave Does Not Respond
			16#1808	Communications Resource Overflow
	NX_WriteObj	Write NX Unit Object	16#0400	Input Value Out of Range
			16#0419	Incorrect Data Type
			16#041B	Data Capacity Exceeded
			16#2C00	NX Message Error
			16#2C01	NX Message Resource Overflow
			16#2C02	NX Message Timeout
16#2C03			Incorrect NX Message Length	

Type	Instruction	Name	Error code	Error name
EtherCAT Communications Instructions	NX_ReadObj	Read NX Unit Object	16#0400	Input Value Out of Range
			16#0410	Text String Format Error
			16#0419	Incorrect Data Type
			16#041C	Different Data Sizes
			16#2C00	NX Message Error
			16#2C01	NX Message Resource Overflow
			16#2C02	NX Message Timeout
IO-Link Communications Instructions	IOL_ReadObj	Read IO-Link Device Object	16#0400	Input Value Out of Range
			16#0410	Text String Format Error
			16#0419	Incorrect Data Type
			16#041C	Different Data Sizes
			16#4800	Device Error Received
			16#4801	Specified Unit Does Not Exist
			16#4802	Message Processing Limit Exceeded
			16#4803	Specified Unit Status Error
			16#4804	Too Many Simultaneous Instruction Executions
			16#4805	Communications Timeout
			16#4806	Invalid Mode
			16#4807	I/O Power OFF Status
			16#4808	Verification Error
	IOL_WriteObj	Write IO-Link Device Object	16#0400	Input Value Out of Range
			16#0419	Incorrect Data Type
			16#041B	Data Capacity Exceeded
			16#4800	Device Error Received
			16#4801	Specified Unit Does Not Exist
			16#4802	Message Processing Limit Exceeded
			16#4803	Specified Unit Status Error
16#4804	Too Many Simultaneous Instruction Executions			
16#4805	Communications Timeout			
16#4806	Invalid Mode			
16#4807	I/O Power OFF Status			
16#4808	Verification Error			

Type	Instruction	Name	Error code	Error name
EtherNet/IP Communications Instructions	CIPOpen	Open CIP Class 3 Connection (Large_Forward_Open)	16#0400	Input Value Out of Range
			16#1C00	Explicit Message Error
			16#1C01	Incorrect Route Path
			16#1C03	CIP Communications Resource Overflow
			16#1C04	CIP Timeout
			16#1C05	Class-3 Connection Not Established
			16#2000	Local IP Address Setting Error
	16#2004	Local IP Address Not Set		
	CIPOpenWithDataSize	Open CIP Class 3 Connection with Specified Data Size	16#0400	Input Value Out of Range
			16#1C00	Explicit Message Error
			16#1C01	Incorrect Route Path
			16#1C03	CIP Communications Resource Overflow
			16#1C04	CIP Timeout
			16#1C05	Class-3 Connection Not Established
			16#2000	Local IP Address Setting Error
	16#2004	Local IP Address Not Set		
	CIPRead	Read Variable Class 3 Explicit	16#0400	Input Value Out of Range
			16#0407	Data Range Exceeded
			16#0419	Incorrect Data Type
			16#1C00	Explicit Message Error
			16#1C02	CIP Handle Out of Range
			16#1C03	CIP Communications Resource Overflow
			16#1C04	CIP Timeout
	16#1C06	CIP Communications Data Size Exceeded		
	CIPWrite	Write Variable Class 3 Explicit	16#0400	Input Value Out of Range
			16#0406	Illegal Data Position Specified
			16#0407	Data Range Exceeded
			16#0419	Incorrect Data Type
16#1C00			Explicit Message Error	
16#1C02			CIP Handle Out of Range	
16#1C03			CIP Communications Resource Overflow	
16#1C04	CIP Timeout			
16#1C06	CIP Communications Data Size Exceeded			

Type	Instruction	Name	Error code	Error name
EtherNet/IP Communications Instructions	CIPSend	Send Explicit Message Class 3	16#0400	Input Value Out of Range
			16#0401	Input Mismatch
			16#0406	Illegal Data Position Specified
			16#0407	Data Range Exceeded
			16#0419	Incorrect Data Type
			16#1C00	Explicit Message Error
			16#1C02	CIP Handle Out of Range
			16#1C03	CIP Communications Resource Overflow
			16#1C04	CIP Timeout
			16#1C06	CIP Communications Data Size Exceeded
	CIPClose	Close CIP Class 3 Connection	16#1C02	CIP Handle Out of Range
			16#1C03	CIP Communications Resource Overflow
	CIPUCMMRead	Read Variable UCMM Explicit	16#0400	Input Value Out of Range
			16#0407	Data Range Exceeded
			16#0419	Incorrect Data Type
			16#1C00	Explicit Message Error
			16#1C01	Incorrect Route Path
			16#1C03	CIP Communications Resource Overflow
			16#1C04	CIP Timeout
			16#2000	Local IP Address Setting Error
	CIPUCMMWrite	Write Variable UCMM Explicit	16#0400	Input Value Out of Range
			16#0406	Illegal Data Position Specified
			16#0419	Incorrect Data Type
			16#1C00	Explicit Message Error
			16#1C01	Incorrect Route Path
			16#1C03	CIP Communications Resource Overflow
			16#1C04	CIP Timeout
			16#2000	Local IP Address Setting Error
		16#2004	Local IP Address Not Set	

Type	Instruction	Name	Error code	Error name
EtherNet/IP Communications Instructions	CIPUCMMSend	Send Explicit Message UCMM	16#0400	Input Value Out of Range
			16#0401	Input Mismatch
			16#0406	Illegal Data Position Specified
			16#0407	Data Range Exceeded
			16#0419	Incorrect Data Type
			16#1C00	Explicit Message Error
			16#1C01	Incorrect Route Path
			16#1C03	CIP Communications Resource Overflow
			16#1C04	CIP Timeout
			16#2000	Local IP Address Setting Error
			16#2004	Local IP Address Not Set
SktUDPCreate	Create UDP Socket	16#0400	Input Value Out of Range	
		16#2000	Local IP Address Setting Error	
		16#2001	TCP/UDP Port Already in Use	
		16#2003	Socket Status Error	
		16#2004	Local IP Address Not Set	
		16#2008	Socket Communications Resource Overflow	
SktUDPRcv	UDP Socket Receive	16#0400	Input Value Out of Range	
		16#0407	Data Range Exceeded	
		16#0419	Incorrect Data Type	
		16#2003	Socket Status Error	
		16#2006	Socket Timeout	
		16#2007	Socket Handle Out of Range	
		16#2008	Socket Communications Resource Overflow	
SktUDPSend	UDP Socket Send	16#0400	Input Value Out of Range	
		16#0406	Data Range Exceeded	
		16#0419	Incorrect Data Type	
		16#2002	Address Resolution Failed	
		16#2003	Socket Status Error	
		16#2007	Socket Handle Out of Range	
		16#2008	Socket Communications Resource Overflow	

Type	Instruction	Name	Error code	Error name
EtherNet/IP Communications Instructions	SkdTCPAccept	Accept TCP Socket	16#0400	Input Value Out of Range
			16#2000	Local IP Address Setting Error
			16#2001	TCP/UDP Port Already in Use
			16#2002	Address Resolution Failed
			16#2003	Socket Status Error
			16#2004	Local IP Address Not Set
			16#2006	Socket Timeout
	SkdTCPConnect	Connect TCP Socket	16#0400	Input Value Out of Range
			16#2000	Local IP Address Setting Error
			16#2001	TCP/UDP Port Already in Use
			16#2002	Address Resolution Failed
			16#2003	Socket Status Error
			16#2004	Local IP Address Not Set
			16#2006	Socket Timeout
	SkdTCPRcv	TCP Socket Receive	16#0400	Input Value Out of Range
			16#0407	Data Range Exceeded
			16#0419	Incorrect Data Type
			16#2003	Socket Status Error
			16#2006	Socket Timeout
			16#2007	Socket Handle Out of Range
	SkdTCPSEND	TCP Socket Send	16#0400	Input Value Out of Range
			16#0406	Data Range Exceeded
			16#0419	Incorrect Data Type
			16#2003	Socket Status Error
			16#2006	Socket Timeout
			16#2007	Socket Handle Out of Range
	SkdGetTCPStatus	Read TCP Socket Status	16#2003	Socket Status Error
			16#2007	Socket Handle Out of Range
			16#2008	Socket Communications Resource Overflow
	SkdClose	Close TCP/UDP Socket	16#2007	Socket Handle Out of Range
			16#2008	Socket Communications Resource Overflow

Type	Instruction	Name	Error code	Error name
EtherNet/IP Communications Instructions	SktClearBuf	Clear TCP/UDP Socket Receive Buffer	16#2007	Socket Handle Out of Range
			16#2008	Socket Communications Resource Overflow
	SktSetOption	Set TCP Socket Option	16#0400	Input Value Out of Range
			16#0419	Incorrect Data Type
			16#2003	Socket Status Error
			16#2007	Socket Handle Out of Range
			16#2008	Socket Communications Resource Overflow
	ChangeIPAdr	Change IP Address	16#0400	Input Value Out of Range
			16#040D	Illegal Unit Specified
			16#2400	No Execution Right
	ChangeFTPAccount	Change FTP Account	16#0400	Input Value Out of Range
			16#040D	Illegal Unit Specified
			16#2400	No Execution Right
	ChangeNTPServerAdr	Change NTP Server Address	16#0400	Input Value Out of Range
			16#040D	Illegal Unit Specified
			16#2400	No Execution Right
	FTPGetFileList	Get FTP Server File List	16#0400	Input Value Out of Range
			16#2403	FTP Client Execution Limit Exceeded
			16#2405	Directory Does Not Exist (FTP)
			16#2406	FTP Server Connection Error
			16#2407	Destination FTP Server Execution Failure
	FTPGetFile	Get File from FTP Server	16#0400	Input Value Out of Range
			16#2403	FTP Client Execution Limit Exceeded
			16#2404	File Number Limit Exceeded
			16#2405	Directory Does Not Exist (FTP)
			16#2406	FTP Server Connection Error
			16#2407	Destination FTP Server Execution Failure
			16#2408	SD Memory Card Access Failed for FTP
			16#2409	Specified File Does Not Exist
			16#240A	Specified File Is Write Protected
			16#240C	Specified File Access Failed

Type	Instruction	Name	Error code	Error name
EtherNet/IP Communications Instructions	FTPputFile	Put File onto FTP Server	16#0400	Input Value Out of Range
			16#2403	FTP Client Execution Limit Exceeded
			16#2404	File Number Limit Exceeded
			16#2405	Directory Does Not Exist (FTP)
			16#2406	FTP Server Connection Error
			16#2407	Destination FTP Server Execution Failure
			16#2408	SD Memory Card Access Failed for FTP
			16#2409	Specified File Does Not Exist
			16#240A	Specified File Is Write Protected
			16#240B	Failed To Delete Specified File
			16#240C	Specified File Access Failed
			FTPremoveFile	Delete FTP Server File
16#2403	FTP Client Execution Limit Exceeded			
16#2404	File Number Limit Exceeded			
16#2405	Directory Does Not Exist (FTP)			
16#2406	FTP Server Connection Error			
16#2407	Destination FTP Server Execution Failure			
16#2409	Specified File Does Not Exist			
FTPremoveDir	Delete FTP Server Directory	16#0400	Input Value Out of Range	
		16#2405	Directory Does Not Exist (FTP)	
		16#2406	FTP Server Connection Error	
		16#2407	Destination FTP Server Execution Failure	
Serial Communications Instructions	ExecPMCR	Protocol Macro	16#0400	Input Value Out of Range
			16#0406	Illegal Data Position Specified
			16#0407	Data Range Exceeded
			16#040D	Illegal Unit Specified
			16#0413	Undefined CJ-series Memory Address
			16#0419	Incorrect Data Type
			16#0C00	Illegal Serial Communications Mode
			16#0800	FINS Error
16#0801	FINS Port Already in Use			

Type	Instruction	Name	Error code	Error name
Serial Communications Instructions	SerialSend	SCU Send Serial	16#0400	Input Value Out of Range
			16#0406	Illegal Data Position Specified
			16#040D	Illegal Unit Specified
			16#0419	Incorrect Data Type
			16#0C00	Illegal Serial Communications Mode
			16#0800	FINS Error
			16#0801	FINS Port Already in Use
	SerialRcv	SCU Receive Serial	16#0400	Input Value Out of Range
			16#0407	Data Range Exceeded
			16#040D	Illegal Unit Specified
			16#0419	Incorrect Data Type
			16#0C00	Illegal Serial Communications Mode
			16#0800	FINS Error
			16#0801	FINS Port Already in Use
	SerialRcvNoClear	SCU Receive Serial without Receive Buffer Clear	16#0400	Input Value Out of Range
			16#0407	Data Range Exceeded
			16#040D	Illegal Unit Specified
			16#0419	Incorrect Data Type
			16#0C00	Illegal Serial Communications Mode
			16#0801	FINS Port Already in Use
	SendCmd	Send Command	16#0400	Input Value Out of Range
			16#0406	Illegal Data Position Specified
			16#0407	Data Range Exceeded
			16#0419	Incorrect Data Type
			16#0800	FINS Error
			16#0801	FINS Port Already in Use
	NX_SerialSend	Send No-protocol Data	16#0400	Input Value Out of Range
			16#0406	Illegal Data Position Specified
16#040D			Illegal Unit Specified	
16#0419			Incorrect Data Type	
16#041D			Too Many Simultaneous Instruction Executions	
16#0C04			Multi-execution of Ports	
16#0C0C			Instruction Executed to Inapplicable Port	
16#0C0D	CIF Unit Initialized			

Type	Instruction	Name	Error code	Error name
Serial Communications Instructions	NX_SerialRcv	Receive No-protocol Data	16#0400	Input Value Out of Range
			16#0406	Illegal Data Position Specified
			16#0407	Data Range Exceeded
			16#040D	Illegal Unit Specified
			16#0419	Incorrect Data Type
			16#041D	Too Many Simultaneous Instruction Executions
			16#0C03	Full Reception Buffer
			16#0C04	Multi-execution of Ports
			16#0C05	Parity Error
			16#0C06	Framing Error
			16#0C07	Overrun Error
			16#0C0B	Serial Communications Timeout
			16#0C0C	Instruction Executed to Inapplicable Port
			16#0C0D	CIF Unit Initialized
	NX_ModbusRtuCmd	Send Modbus-RTU General Command	16#0400	Input Value Out of Range
			16#0406	Illegal Data Position Specified
			16#0407	Data Range Exceeded
			16#040D	Illegal Unit Specified
			16#0419	Incorrect Data Type
			16#041D	Too Many Simultaneous Instruction Executions
			16#0C03	Full Reception Buffer
			16#0C04	Multi-execution of Ports
			16#0C05	Parity Error
			16#0C06	Framing Error
16#0C07	Overrun Error			
16#0C08	CRC Mismatch			
16#0C0B	Serial Communications Timeout			
16#0C0C	Instruction Executed to Inapplicable Port			
16#0C0D	CIF Unit Initialized			
16#0C10	Exceptional Modbus Response			
16#0C11	Invalid Modbus Response			

Type	Instruction	Name	Error code	Error name
Serial Communications Instructions	NX_ModbusRtuRead	Send Modbus-RTU Read Command	16#0400	Input Value Out of Range
			16#0406	Illegal Data Position Specified
			16#040D	Illegal Unit Specified
			16#0419	Incorrect Data Type
			16#041D	Too Many Simultaneous Instruction Executions
			16#0C03	Full Reception Buffer
			16#0C04	Multi-execution of Ports
			16#0C05	Parity Error
			16#0C06	Framing Error
			16#0C07	Overrun Error
			16#0C08	CRC Mismatch
			16#0C0B	Serial Communications Timeout
			16#0C0C	Instruction Executed to Inapplicable Port
			16#0C0D	CIF Unit Initialized
	16#0C10	Exceptional Modbus Response		
	16#0C11	Invalid Modbus Response		
	NX_ModbusRtuWrite	Send Modbus-RTU Write Command	16#0400	Input Value Out of Range
			16#0406	Illegal Data Position Specified
			16#040D	Illegal Unit Specified
			16#0419	Incorrect Data Type
			16#041D	Too Many Simultaneous Instruction Executions
			16#0C03	Full Reception Buffer
			16#0C04	Multi-execution of Ports
			16#0C05	Parity Error
16#0C06			Framing Error	
16#0C07			Overrun Error	
16#0C08			CRC Mismatch	
16#0C0B			Serial Communications Timeout	
16#0C0C			Instruction Executed to Inapplicable Port	
16#0C0D			CIF Unit Initialized	
16#0C10	Exceptional Modbus Response			
16#0C11	Invalid Modbus Response			

Type	Instruction	Name	Error code	Error name
Serial Communications Instructions	NX_SerialSigCtl	Serial Control Signal ON/OFF Switching	16#0400	Input Value Out of Range
			16#040D	Illegal Unit Specified
			16#0419	Incorrect Data Type
			16#041D	Too Many Simultaneous Instruction Executions
			16#0C04	Multi-execution of Ports
			16#0C0B	Serial Communications Timeout
			16#0C0C	Instruction Executed to Inapplicable Port
			16#0C0D	CIF Unit Initialized
	NX_SerialSigRead	Read Serial Control Signal	16#0400	Input Value Out of Range
			16#040D	Illegal Unit Specified
			16#0419	Incorrect Data Type
			16#041D	Exceeded Simultaneous Instruction Executed Resources
			16#0C04	Multi-execution of Ports
			16#0C0B	Serial Communications Timeout
			16#0C0C	Instruction Executed to Inapplicable Port
			16#0C0D	CIF Unit Initialized
	NX_SerialStatusRead	Read Serial Port Status	16#0400	Input Value Out of Range
			16#040D	Illegal Unit Specified
			16#0419	Incorrect Data Type
			16#041D	Exceeded Simultaneous Instruction Executed Resources
			16#0C04	Multi-execution of Ports
			16#0C0B	Serial Communications Timeout
			16#0C0C	Instruction Executed to Inapplicable Port
			16#0C0D	CIF Unit Initialized
	NX_SerialBufClear	Clear Buffer	16#0400	Input Value Out of Range
			16#040D	Illegal Unit Specified
			16#0419	Incorrect Data Type
			16#041D	Too Many Simultaneous Instruction Executions
16#0C04			Multi-execution of Ports	
16#0C0B			Serial Communications Timeout	
16#0C0C			Instruction Executed to Inapplicable Port	
16#0C0D			CIF Unit Initialized	

Type	Instruction	Name	Error code	Error name
Serial Communications Instructions	NX_SerialStartMon	Start Serial Line Monitoring	16#0400	Input Value Out of Range
			16#040D	Illegal Unit Specified
			16#0419	Incorrect Data Type
			16#041D	Too Many Simultaneous Instruction Executions
			16#0C04	Multi-execution of Ports
			16#0C0B	Serial Communications Timeout
			16#0C0C	Instruction Executed to Inapplicable Port
	NX_SerialStopMon	Stop Serial Line Monitoring	16#0400	Input Value Out of Range
			16#040D	Illegal Unit Specified
			16#0419	Incorrect Data Type
			16#041D	Too Many Simultaneous Instruction Executions
			16#0C04	Multi-execution of Ports
			16#0C0B	Serial Communications Timeout
			16#0C0C	Instruction Executed to Inapplicable Port
SD Memory Card Instructions	FileWriteVar	Write Variable to File	16#0400	Input Value Out of Range
			16#1400	SD Memory Card Access Failure
			16#1401	SD Memory Card Write-protected
			16#1402	SD Memory Card Insufficient Capacity
			16#1403	File Does Not Exist
			16#1404	Too Many Files/ Directories
			16#1405	File Already in Use
			16#1409	That File Name Already Exists
			16#140A	Write Access Denied
			16#140B	Too Many Files Open
			16#140D	File or Directory Name Is Too Long
	FileReadVar	Read Variable from File	16#0400	Input Value Out of Range
			16#1400	SD Memory Card Access Failure
			16#1403	File Does Not Exist
			16#1405	File Already in Use
			16#140B	Too Many Files Open
			16#140D	File or Directory Name Is Too Long
			16#140E	SD Memory Card Access Failed

Type	Instruction	Name	Error code	Error name
SD Memory Card Instructions	FileOpen	Open File	16#0400	Input Value Out of Range
			16#1400	SD Memory Card Access Failure
			16#1401	SD Memory Card Write-protected
			16#1403	File Does Not Exist
			16#1404	Too Many Files/ Directories
	FileOpen	Open File	16#1405	File Already in Use
			16#140A	Write Access Denied
			16#140B	Too Many Files Open
			16#140D	File or Directory Name Is Too Long
			16#140E	SD Memory Card Access Failed
	FileClose	Close File	16#1400	SD Memory Card Access Failure
			16#1403	File Does Not Exist
			16#1405	File Already in Use
			16#140E	SD Memory Card Access Failed
	FileSeek	Seek File	16#0400	Input Value Out of Range
			16#1400	SD Memory Card Access Failure
			16#1403	File Does Not Exist
			16#1405	File Already in Use
			16#1407	Offset Out of Range
			16#140E	SD Memory Card Access Failed
	FileRead	Read File	16#0406	Illegal Data Position Specified
			16#0419	Incorrect Data Type
			16#1400	SD Memory Card Access Failure
			16#1403	File Does Not Exist
			16#1405	File Already in Use
			16#1406	Open Mode Mismatch
			16#140E	SD Memory Card Access Failed
	FileWrite	Write File	16#0406	Illegal Data Position Specified
			16#0419	Incorrect Data Type
			16#1400	SD Memory Card Access Failure
			16#1401	SD Memory Card Write-protected
			16#1402	SD Memory Card Insufficient Capacity
16#1403			File Does Not Exist	
16#1405			File Already in Use	
16#1406			Open Mode Mismatch	
16#140E			SD Memory Card Access Failed	

Type	Instruction	Name	Error code	Error name
SD Memory Card Instructions	FileGets	Get Text String	16#1400	SD Memory Card Access Failure
			16#1403	File Does Not Exist
			16#1405	File Already in Use
			16#1406	Open Mode Mismatch
			16#140E	SD Memory Card Access Failed
	FilePuts	Put Text String	16#1400	SD Memory Card Access Failure
			16#1401	SD Memory Card Write-protected
			16#1402	SD Memory Card Insufficient Capacity
			16#1403	File Does Not Exist
			16#1405	File Already in Use
	FilePuts	Put Text String	16#1406	Open Mode Mismatch
			16#140E	SD Memory Card Access Failed
	FileCopy	Copy File	16#0400	Input Value Out of Range
			16#1400	SD Memory Card Access Failure
			16#1401	SD Memory Card Write-protected
			16#1402	SD Memory Card Insufficient Capacity
			16#1403	File Does Not Exist
			16#1404	Too Many Files/ Directories
			16#1405	File Already in Use
			16#1409	That File Name Already Exists
			16#140A	Write Access Denied
			16#140B	Too Many Files Open
			16#140D	File or Directory Name Is Too Long
			16#140E	SD Memory Card Access Failed
	FileRemove	Delete File	16#0400	Input Value Out of Range
			16#1400	SD Memory Card Access Failure
			16#1401	SD Memory Card Write-protected
			16#1403	File Does Not Exist
			16#1405	File Already in Use
			16#140A	Write Access Denied
			16#140B	Too Many Files Open
			16#140E	SD Memory Card Access Failed

Type	Instruction	Name	Error code	Error name
SD Memory Card Instructions	FileRename	Change File Name	16#0400	Input Value Out of Range
			16#1400	SD Memory Card Access Failure
			16#1401	SD Memory Card Write-protected
			16#1403	File Does Not Exist
			16#1404	Too Many Files/ Directories
			16#1405	File Already in Use
			16#1408	Directory Not Empty
			16#1409	That File Name Already Exists
			16#140A	Write Access Denied
			16#140B	Too Many Files Open
			16#140D	File or Directory Name Is Too Long
	16#140E	SD Memory Card Access Failed		
	DirCreate	Create Directory	16#0400	Input Value Out of Range
			16#1400	SD Memory Card Access Failure
			16#1401	SD Memory Card Write-protected
			16#1402	SD Memory Card Insufficient Capacity
			16#1404	Too Many Files/ Directories
			16#1405	File Already in Use
			16#1409	That File Name Already Exists
			16#140B	Too Many Files Open
			16#140C	Directory Does Not Exist
			16#140D	File or Directory Name Is Too Long
			16#140E	SD Memory Card Access Failed
	DirRemove	Delete Directory	16#0400	Input Value Out of Range
			16#1400	SD Memory Card Access Failure
			16#1401	SD Memory Card Write-protected
			16#1405	File Already in Use
			16#1408	Directory Not Empty
			16#140A	Write Access Denied
			16#140B	Too Many Files Open
			16#140C	Directory Does Not Exist
			16#140D	File or Directory Name Is Too Long
			16#140E	SD Memory Card Access Failed

Type	Instruction	Name	Error code	Error name
SD Memory Card Instructions	BackupToMemoryCard	SD Memory Card Backup	16#0400	Input Value Out of Range
			16#1400	SD Memory Card Access Failure
			16#1401	SD Memory Card Write-protected
			16#1402	SD Memory Card Insufficient Capacity
			16#1404	Too Many Files/ Directories
			16#1409	That File Name Already Exists
			16#140C	Directory Does Not Exist
			16#140E	SD Memory Card Access Failed
			16#140F	Backup Operation Already in Progress
			16#1410	Cannot Execute Backup
			16#1411	Unit/Slave Backup Failed

A-2 Error Code Descriptions

This section provides a table of errors (events) that occur for instructions. The lower four digits of the event code give the error code for the instruction. For descriptions of the error codes, refer to the descriptions of the corresponding event codes. For example, if the error code of the instruction is 16#0400, refer to the description of the event with event code 54010400 hex.

Event levels are given in the table as follows:

Maj: Major fault level

Prt: Partial fault level

Min: Minor fault level

Obs: Observation

Info: Information

A version in parentheses in the *Event code* column is the unit version of the CPU Unit when the event occurs for only specific unit versions of the CPU Unit.

Refer to *A-3 Error Code Details* for details on the error codes.

Refer to the *NJ/NX-series Troubleshooting Manual* (Cat. No. W503) for error (event) concepts and for all of the event codes that may occur for an NJ/NX-series Controller. Event codes for instructions are supported by CPU Units with unit version 1.02 or later.

Event code	Event name	Meaning	Assumed cause	Level					Refer- ence
				Maj	Prt	Min	Obs	Info	
54010400 hex	Input Value Out of Range	An input parameter for an instruction exceeded the valid range for an input variable. Or, division by an integer of 0 occurred in division or remainder calculations.	<ul style="list-style-type: none"> An input parameter for an instruction exceeded the valid range for an input variable. Or, division by an integer of 0 occurred in division or remainder calculations. 				√		page A-56
54010401 hex	Input Mismatch	The relationship for the instruction input parameters did not meet required conditions. Or, a numeric value during or after instruction execution did not meet conditions.	<ul style="list-style-type: none"> The relationship for an input parameter did not meet required conditions. A value when processing an instruction or in the result does not meet the conditions. 				√		page A-56
54010402 hex	Floating-point Error	Non-numeric data was input for a floating-point number input parameter to an instruction.	<ul style="list-style-type: none"> Non-numeric data was input for a floating-point number input parameter to an instruction. 				√		page A-57
54010403 hex	BCD Error	A value that was not BCD was input for a BCD input parameter to an instruction.	<ul style="list-style-type: none"> A hexadecimal digit of A, B, C, D, E, or F was input for a BCD input parameter to an instruction. 				√		page A-57

Event code	Event name	Meaning	Assumed cause	Level					Reference
				Maj	Prt	Min	Obs	Info	
54010404 hex	Signed BCD Error	An illegal value was input for the most significant digit for a signed BCD input parameter to an instruction.	<ul style="list-style-type: none"> An illegal value was input for the most significant digit for a signed BCD input parameter to an instruction. The most-significant digit was 2 to F when <code>_BCD0</code> was specified as the BCD format. The most-significant digit was A, B, C, D, or E when <code>_BCD2</code> was specified as the BCD format. The most-significant digit was B, C, D, or E when <code>_BCD3</code> was specified as the BCD format. 				√		page A-58
54010405 hex	Illegal Bit Position Specified	The bit position specified for an instruction was illegal.	<ul style="list-style-type: none"> The bit position specified for an instruction exceeds the data range. 				√		page A-58
54010406 hex	Illegal Data Position Specified	A memory address or data size that was specified for the instruction is not suitable.	<ul style="list-style-type: none"> A memory address that was specified for an instruction was outside the valid range. The data size that was specified for an instruction exceeded the valid range. For example, the data type of a variable and the data size may not agree. 				√		page A-59
54010407 hex	Data Range Exceeded	The results of instruction processing exceeded the data area range of the output parameter.	<ul style="list-style-type: none"> The results of instruction processing, such as the number of array elements, exceeded the data area range of the output parameter. 				√		page A-59
54010409 hex	No Errors to Clear	An instruction to clear a Controller error was executed when there was no error in the Controller.	<ul style="list-style-type: none"> An instruction to clear a Controller error was executed when there was no error in the Controller. 				√		page A-60
5401040B hex	No User Errors to Clear	An instruction to clear user-defined errors was executed when there was no user-defined error.	<ul style="list-style-type: none"> An instruction to clear user-defined errors was executed when there was no user-defined error. 				√		page A-60
5401040C hex	Limit Exceeded for User-defined Errors	An attempt was made to use the Create User-defined Error instruction to create more than the maximum number of user-defined errors.	<ul style="list-style-type: none"> An attempt was made to use the Create User-defined Error instruction to create more than the maximum number of user-defined errors. 				√		page A-61
5401040D hex	Illegal Unit Specified	The Unit specified for an instruction does not exist.	<ul style="list-style-type: none"> A Unit that does not exist in the Unit configuration information was specified. A Unit that is in the Unit configuration information was specified, but the Units does not actually exist in the Controller. 				√		page A-61
5401040F hex	Unit Restart Failed	Restarting a Special I/O Unit or CPU Bus Unit failed.	<ul style="list-style-type: none"> The Special I/O Unit or CPU Bus Unit is processing data. 				√		page A-62

Event code	Event name	Meaning	Assumed cause	Level					Reference
				Maj	Prt	Min	Obs	Info	
54010410 hex	Text String Format Error	The text string input to an instruction is not correct.	<ul style="list-style-type: none"> The text string that is input to the instruction for conversion to a number does not represent a number or it does not represent a positive number. The input text string does not end in NULL. 				√		page A-62
54010411 hex	Illegal Program Specified	The program specified for an instruction does not exist.	<ul style="list-style-type: none"> The program specified by the function does not exist (e.g., it was deleted). 				√		page A-63
54010413 hex	Undefined CJ-series Memory Address	The required specification is missing for a variable for which CJ-series Unit memory must be specified.	<ul style="list-style-type: none"> The required AT specification is missing for a variable for which CJ-series Unit memory must be specified. 				√		page A-63
54010414 hex	Stack Underflow	There is no data in a stack.	<ul style="list-style-type: none"> An attempt was made to read data from a stack that contains no data. 				√		page A-64
54010416 hex	Illegal Number of Array Elements or Dimensions	The valid range was exceeded for the number of array elements or dimensions in an array I/O parameter for an instruction.	<ul style="list-style-type: none"> The valid range was exceeded for the number of array elements or dimensions in an array I/O parameter for an instruction. 				√		page A-64
54010417 hex	Specified Task Does Not Exist	The task specified for the instruction does not exist.	<ul style="list-style-type: none"> The specified task does not exist. 				√		page A-65
54010418 hex	Unallowed Task Specification	An unallowed task was specified for an instruction.	<ul style="list-style-type: none"> The local task, the primary periodic task, or a periodic task was specified. 				√		page A-65
54010419 hex	Incorrect Data Type	A data type that cannot be used for an instruction is specified for an input or in-out variable.	<ul style="list-style-type: none"> A data type that cannot be used for an instruction is specified for an input or in-out variable. 				√		page A-66
5401041A hex	Multi-execution of Instructions	Multi-execution was specified for an instruction that does not support it.	<ul style="list-style-type: none"> Execution of an instruction that does not support multi-execution of instructions was specified more than once. 				√		page A-66
5401041B hex (Ver. 1.02 or later)	Data Capacity Exceeded	Processing was not possible because the data that was passed to the instruction was too large.	<ul style="list-style-type: none"> Data that exceeded the size that can be processed was passed to an instruction. 				√		page A-67
5401041C hex (Ver. 1.04 or later)	Different Data Sizes	The size of the data specified for instruction input or in-out data is different from the size of the target parameter.	<ul style="list-style-type: none"> Data of a size that is different from the size of the target parameter was specified for the input or in-out data of an instruction. 				√		page A-67
5401041D hex (Ver. 1.05 or later)	Exceeded Simultaneous Instruction Executed Resources	The maximum resources that you can use for the relevant instruction group at the same time was exceeded.	<ul style="list-style-type: none"> More than the maximum number of relevant instructions were executed at the same time. 				√		page A-68
54010800 hex	FINS Error	An error occurred when a FINS command was sent or received.	<ul style="list-style-type: none"> An error occurred when a FINS command was sent or received. 				√		page A-68
54010801 hex	FINS Port Already in Use	The FINS port is being used.	<ul style="list-style-type: none"> The FINS port is being used. 				√		page A-69

Event code	Event name	Meaning	Assumed cause	Level					Reference
				Maj	Prt	Min	Obs	Info	
54010C00 hex	Illegal Serial Communications Mode	The Serial Communications Unit is not in the serial communications mode required to execute an instruction.	<ul style="list-style-type: none"> The serial communications port for the Serial Communications Unit is not set to the mode expected by the instruction. 				√		page A-69
54010C03 hex (Ver. 1.11 or later)	Full Reception Buffer	The reception buffer is full.	<ul style="list-style-type: none"> The reception buffer is full. 				√		page A-70
54010C04 hex (Ver. 1.11 or later)	Multi-execution of Ports	The serial communications instructions that cannot be executed simultaneously were executed.	<ul style="list-style-type: none"> An instruction was executed while another instruction that cannot be executed at the same time with the former instruction was executed. 				√		page A-70
54010C05 hex (Ver. 1.11 or later)	Parity Error	A parity error occurred in the data received.	<ul style="list-style-type: none"> The communications settings or baud rate settings are not compatible with the remote device. Noise 				√		page A-71
54010C06 hex (Ver. 1.11 or later)	Framing Error	A framing error occurred in the data received.	<ul style="list-style-type: none"> The communications settings or baud rate settings are not compatible with the remote device. Noise 				√		page A-71
54010C07 hex (Ver. 1.11 or later)	Overrun Error	An overrun error occurred in the data received.	<ul style="list-style-type: none"> The next data was received during processing of received data because the baud rate is too high. 				√		page A-72
54010C08 hex (Ver. 1.11 or later)	CRC Mismatch	The receive data had different CRC.	<ul style="list-style-type: none"> A wrong message was received. Noise 				√		page A-72
54010C0B hex (Ver. 1.11 or later)	Serial Communications Timeout	A timeout occurred in serial communications.	<ul style="list-style-type: none"> Wiring to the remote device is not connected. Power to the remote device is OFF. The communications settings or baud rate settings are not compatible with the remote device. Noise 				√		page A-73
54010C0C hex (Ver. 1.11 or later)	Instruction Executed to Inapplicable Port	An instruction was executed to an inapplicable port.	<ul style="list-style-type: none"> An instruction was executed to an inapplicable port. 				√		page A-73
54010C0D hex (Ver. 1.13 or later)	CIF Unit Initialized	A CIF Unit was initialized, so the communications data buffered in the CIF Unit was lost.	<ul style="list-style-type: none"> A CIF Unit was initialized. 				√		page A-74
54010C10 hex (Ver. 1.11 or later)	Exceptional Modbus Response	An exceptional code was returned from the Modbus slave.	<ul style="list-style-type: none"> An error was detected on the Modbus slave. 				√		page A-74
54010C11 hex (Ver. 1.11 or later)	Invalid Modbus Response	An unexpected response was returned from the Modbus slave.	<ul style="list-style-type: none"> The function code or data size of the response received from the Modbus slave was incorrect. 				√		page A-75

Event code	Event name	Meaning	Assumed cause	Level					Reference
				Maj	Prt	Min	Obs	Info	
54011400 hex	SD Memory Card Access Failure	SD Memory Card access failed when an instruction was executed.	<ul style="list-style-type: none"> An SD Memory Card is either not inserted or is not inserted properly. The SD Memory Card is broken. The SD Memory Card slot is broken. 				√		page A-75
54011401 hex	SD Memory Card Write-protected	An attempt was made to write to a write-protected SD Memory Card when an instruction was executed.	<ul style="list-style-type: none"> An attempt was made to write to a write-protected SD Memory Card. 				√		page A-76
54011402 hex	SD Memory Card Insufficient Capacity	The capacity of the SD Memory Card was insufficient when writing to the SD Memory Card for an instruction.	<ul style="list-style-type: none"> The SD Memory Card has run out of free space. 				√		page A-76
54011403 hex	File Does Not Exist	The file specified for an instruction does not exist. Or, the specified file is corrupted.	<ul style="list-style-type: none"> The specified file does not exist. The specified file is corrupted. The SD Memory Card cannot be normally accessed due to a contact failure or other causes. 				√		page A-77
54011404 hex	Too Many Files/Directories	The maximum number of files/directories was exceeded when creating a file/directory for an instruction.	<ul style="list-style-type: none"> The number of files or directories exceeded the maximum number. 				√		page A-77
54011405 hex	File Already in Use	A file specified for an instruction cannot be accessed because it is already being used.	<ul style="list-style-type: none"> An instruction attempted to read or write a file already being accessed by another instruction. 				√		page A-78
54011406 hex	Open Mode Mismatch	A file operation for an instruction was inconsistent with the open mode of the file.	<ul style="list-style-type: none"> The file open mode specified by the Open File instruction does not match the file operation attempted by a subsequent SD Memory Card instruction. 				√		page A-78
54011407 hex	Offset Out of Range	Access to the address is not possible for the offset specified for an instruction.	<ul style="list-style-type: none"> An attempt was made to access beyond the size of the file. 				√		page A-79
54011408 hex	Directory Not Empty	A directory was not empty when the Delete Directory instruction was executed or when an attempt was made to change the directory name.	<ul style="list-style-type: none"> A directory was not empty when the Delete Directory instruction was executed. A directory contained another directory when an attempt was made to change the directory name. 				√		page A-79
54011409 hex	That File Name Already Exists	An instruction could not be executed because the file name specified for the instruction already exists.	<ul style="list-style-type: none"> A file already exists with the same name as the name specified for the instruction to create. 				√		page A-80
5401140A hex	Write Access Denied	An attempt was made to write to a write-protected file or directory when an instruction was executed.	<ul style="list-style-type: none"> The file or directory specified for the instruction to write is write-protected. 				√		page A-80

Event code	Event name	Meaning	Assumed cause	Level					Reference
				Maj	Prt	Min	Obs	Info	
5401140B hex	Too Many Files Open	The maximum number of open files was exceeded when opening a file for an instruction.	<ul style="list-style-type: none"> The maximum number of open files was exceeded when opening a file for an instruction. 				√		page A-81
5401140C hex	Directory Does Not Exist	The directory specified for an instruction does not exist.	<ul style="list-style-type: none"> The directory specified for an instruction does not exist. 				√		page A-81
5401140D hex	File or Directory Name Is Too Long	The file name or directory name that was specified for an instruction is too long.	<ul style="list-style-type: none"> The file name or directory name that was specified for the instruction to create is too long. 				√		page A-82
5401140E hex	SD Memory Card Access Failed	SD Memory Card access failed.	<ul style="list-style-type: none"> The SD Memory Card is broken. The SD Memory Card slot is broken. 				√		page A-82
5401140F hex (Ver. 1.08 or later)	Backup Operation Already in Progress	Another backup operation is already in progress.	<ul style="list-style-type: none"> Another backup operation is already in progress. 				√		page A-83
54011410 hex (Ver. 1.08 or later)	Cannot Execute Backup	Execution of a backup operation was not possible because execution of another operation was in progress.	<ul style="list-style-type: none"> Execution of the instruction was attempted during execution of online editing. Execution of the instruction was attempted during execution of a Save Cam Table instruction. Execution of the instruction was attempted while a CPU Unit name change operation was in progress. 				√		page A-83
54011411 hex (Ver. 1.08 or later)	Unit/Slave Backup Failed	A Unit/slave backup operation failed.	<ul style="list-style-type: none"> A Unit/slave backup operation failed. 				√		page A-84
54011800 hex	EtherCAT Communications Error	Accessing the EtherCAT network failed when an instruction was executed.	<ul style="list-style-type: none"> The EtherCAT network is not in a usable status. 				√		page A-85
54011801 hex	EtherCAT Slave Does Not Respond	Accessing the target slave failed when an instruction was executed.	<ul style="list-style-type: none"> The target slave does not exist. The target slave is not in an operating condition. 				√		page A-85
54011802 hex	EtherCAT Timeout	A timeout occurred while trying to access an EtherCAT slave when an instruction was executed.	<ul style="list-style-type: none"> Communications with the target slave timed out. 				√		page A-86
54011803 hex	Reception Buffer Overflow	The receive data from an EtherCAT slave overflowed the receive buffer when an instruction was executed.	<ul style="list-style-type: none"> The receive data from the slave overflowed the receive buffer. 				√		page A-86
54011804 hex	SDO Abort Error	An SDO abort error was received from an EtherCAT slave when an instruction was executed.	<ul style="list-style-type: none"> Depends on the specifications of the slave. 				√		page A-87
54011805 hex	Saving Packet Monitor File	An instruction for packet monitoring was executed while saving an EtherCAT packet monitor file.	<ul style="list-style-type: none"> An instruction for packet monitoring was executed while saving an EtherCAT packet monitor file. 				√		page A-87

Event code	Event name	Meaning	Assumed cause	Level					Reference
				Maj	Prt	Min	Obs	Info	
54011806 hex	Packet Monitoring Function Not Started	A Stop EtherCAT Packet Monitor instruction was executed when EtherCAT packet monitoring was stopped.	<ul style="list-style-type: none"> A Stop EtherCAT Packet Monitor instruction was executed when EtherCAT packet monitoring was stopped. 				√		page A-88
54011807 hex	Packet Monitoring Function in Operation	A Start EtherCAT Packet Monitor instruction was executed when EtherCAT packet monitoring was already being executed.	<ul style="list-style-type: none"> The Start EtherCAT Packet Monitor instruction was executed again while the EtherCAT packet monitoring function was already in operation. 				√		page A-88
54011808 hex	Communications Resource Overflow	More than 32 EtherCAT communications instructions were executed at the same time.	<ul style="list-style-type: none"> More than 32 EtherCAT communications instructions were executed at the same time. The EtherCAT communications instructions are listed below. EC_CoESDOWrite instruction EC_CoESDORead instruction EC_ConnectSlave instruction EC_DisconnectSlave instruction EC_StartMon instruction EC_SaveMon instruction EC_StopMon instruction EC_CopyMon instruction 				√		page A-89
54011809 hex (Ver. 1.01 or later)	Packet Monitoring Function Not Supported	Packets cannot be monitored.	<ul style="list-style-type: none"> An instruction for packet monitoring was executed for a CPU Unit that does not support packet monitoring. 				√		page A-89
54011C00 hex	Explicit Message Error	An error response code was returned for an explicit message that was sent with a CIP communications instruction.	<ul style="list-style-type: none"> Depends on the nature of the error. 				√		page A-90
54011C01 hex	Incorrect Route Path	The format of the route path that is specified for a CIP communications instruction is not correct.	<ul style="list-style-type: none"> The format of the route path that is specified for a CIP communications instruction is not correct. 				√		page A-90
54011C02 hex	CIP Handle Out of Range	The handle that is specified for the CIP communications instruction is not correct.	<ul style="list-style-type: none"> The handle that is specified for the CIP communications instruction is not correct. 				√		page A-91
54011C03 hex	CIP Communications Resource Overflow	The maximum resources that you can use for CIP communications instructions at the same time was exceeded.	<ul style="list-style-type: none"> More than 32 CIP communications instructions were executed at the same time. An attempt was made to use more than 32 handles at the same time. 				√		page A-91

Event code	Event name	Meaning	Assumed cause	Level					Reference
				Maj	Prt	Min	Obs	Info	
54011C04 hex	CIP Timeout	A CIP timeout occurred during execution of a CIP communications instruction.	<ul style="list-style-type: none"> A device does not exist for the specified IP address. The CIP connection for the specified handle timed out and was closed. Power to the remote device is OFF. Communications are stopped at the remote device. The Ethernet cable connector for EtherNet/IP is disconnected. The Ethernet cable for EtherNet/IP is disconnected. Noise 				√		page A-92
54011C05 hex (Ver. 1.06 or later)	Class-3 Connection Not Established	Establishing a class-3 connection failed for a CIP communications instruction.	<ul style="list-style-type: none"> The CIPOpen instruction was executed for a device that does not support class 3 (Large_Forward_Open). The CIPOpenWithData-Size instruction was executed with a specified data size of 510 bytes or larger for a device that does not support class 3 (Large_Forward_Open). 				√		page A-93
54011C06 hex (Ver. 1.06 or later)	CIP Communications Data Size Exceeded	An attempt was made to send a class-3 explicit message with a data size that is larger than the sendable size with a CIP communications instruction.	<ul style="list-style-type: none"> The data size that was specified for the input variable to the CIPRead, CIPWrite, or CIPSend instruction exceeded the data size that was specified with the CIPOpen-WithData-Size instruction. 				√		page A-94
54012000 hex	Local IP Address Setting Error	An instruction was executed when there was a setting error in the local IP address.	<ul style="list-style-type: none"> An instruction was executed when there was a setting error in the local IP address. 				√		page A-94
54012001 hex	TCP/UDP Port Already in Use	The UDP or TCP port was already in use when the instruction was executed.	<ul style="list-style-type: none"> The UDP or TCP port is already in use. 				√		page A-95
54012002 hex	Address Resolution Failed	Address resolution failed for a remote node with the host name that was specified in the instruction.	<ul style="list-style-type: none"> The host name specified for the instruction is not correct. The hosts and DNS settings in the Controller are incorrect. The DNS server settings are incorrect. 				√		page A-95

Event code	Event name	Meaning	Assumed cause	Level					Refer-ence
				Maj	Prt	Min	Obs	Info	
54012003 hex	Socket Status Error	The status was not suitable for execution of the socket service instruction.	<ul style="list-style-type: none"> • SktUDPCreate Instruction The UDP port specified with the <i>SrcUdpPort</i> input variable is in one of the following states. <ul style="list-style-type: none"> • It is already open. • It is being closed. • SktUDPRcv Instruction <ul style="list-style-type: none"> • The specified socket is receiving data. • The specified socket is closed. • SktUDPSend Instruction <ul style="list-style-type: none"> • The specified socket is sending data. • The specified socket is closed. • SktTCPAccept Instruction The specified TCP port is in one of the following states. <ul style="list-style-type: none"> • The port is being opened. • The port is being closed. • A connection is already established for this instruction for the same IP address and TCP port. • SktTCPConnect Instruction <ul style="list-style-type: none"> • The TCP port that is specified with the <i>SrcTcpPort</i> input variable is already open. • The remote node that is specified with <i>DstAdr</i> input variable does not exist. • The remote node that is specified with <i>DstAdr</i> and <i>DstTcpPort</i> input variables is not waiting for a connection. • SktTCPRcv Instruction <ul style="list-style-type: none"> • The specified socket is receiving data. • The specified socket is closed. • SktTCPSEND Instruction <ul style="list-style-type: none"> • The specified socket is sending data. • The specified socket is closed. • The send buffer of the specified socket is full (because the power to the remote node is OFF, the line is disconnected, etc.) • SktSetOption Instruction <ul style="list-style-type: none"> • The specified socket already started transmission. 				√		page A-96

Event code	Event name	Meaning	Assumed cause	Level					Reference
				Maj	Prt	Min	Obs	Info	
54012003 hex	Socket Status Error	The status was not suitable for execution of the socket service instruction.	<ul style="list-style-type: none"> An option type which is not supported by the specified socket was selected. 				√		page A-96
54012004 hex	Local IP Address Not Set	The local IP address was not set when a socket service instruction was executed.	<ul style="list-style-type: none"> There is a BOOTP server setting error. The BOOTP server does not exist. The local IP address is not set because operation just started. 				√		page A-98
54012006 hex	Socket Timeout	A timeout occurred for a socket service instruction.	<ul style="list-style-type: none"> SktTCPAccept instruction: There was no request for a connection from the remote node during the user-set timeout time. SktTCPPrCv or SktUDPrCv instruction: Data was not received from the remote node during the user-set timeout time. 				√		page A-98
54012007 hex	Socket Handle Out of Range	The handle that is specified for the socket service instruction is not correct.	<ul style="list-style-type: none"> The handle that is specified for the socket service instruction is not correct. 				√		page A-99
54012008 hex	Socket Communications Resource Overflow	The maximum resources that you can use for socket service instructions at the same time was exceeded.	<ul style="list-style-type: none"> More than 32 socket service instructions were executed at the same time. More than 30 socket handles were used at the same time. (For CPU Units with unit version 1.02 or earlier, more than 16 socket handles were used at the same time.) 				√		page A-99

Event code	Event name	Meaning	Assumed cause	Level					Reference
				Maj	Prt	Min	Obs	Info	
54012400 hex (Ver. 1.02 or later)	No Execution Right	An instruction to change the settings of an EtherNet/IP port was executed when execution was not possible.	<ul style="list-style-type: none"> An instruction to change the settings of the built-in EtherNet/IP port or a CJ-series EtherNet/IP Unit was executed when restart processing was in progress for the built-in EtherNet/IP port. An instruction to change the settings of a CJ-series EtherNet/IP Unit was executed when restart processing was in progress for the Unit. An instruction to change the settings of the built-in EtherNet/IP port or a CJ-series EtherNet/IP Unit was executed when changing settings was in progress for an instruction or CIP message for the built-in EtherNet/IP port. An instruction to change the settings of a CJ-series EtherNet/IP Unit was executed when changing settings was in progress for an instruction or CIP message for the Unit. The unit number that was specified for the instruction is not for a built-in EtherNet/IP port or a CJ-series EtherNet/IP Unit. 				√		page A-100
54012401 hex (Ver. 1.02 or later)	Settings Update Failed	It was not possible to update the settings of the CJ-series EtherNet/IP Unit that were changed.	<ul style="list-style-type: none"> Restart processing for a Unit or built-in EtherNet/IP port was started during execution of an instruction to change the settings of a CJ-series EtherNet/IP Unit. 				√		page A-101
54012402 hex (Ver. 1.02 or later)	Too Many Simultaneous Instruction Executions	Too many instructions to change the communications setup of the Controller were executed at the same time.	<ul style="list-style-type: none"> Two or more instructions to change the communications setup of the Controller were executed at the same time. 				√		page A-101
54012403 hex (Ver. 1.08 or later)	FTP Client Execution Limit Exceeded	Too many FTP client communications instructions were executed at the same time.	<ul style="list-style-type: none"> Four or more FTP client communications instructions were executed at the same time. 				√		page A-102
54012404 hex (Ver. 1.08 or later)	File Number Limit Exceeded	The number of files specified with a wildcard for an FTP client communications instruction exceeded 1,000.	<ul style="list-style-type: none"> The number of files specified with a file name that contained a wildcard for an FTP client communications instruction exceeded 1,000. 				√		page A-102
54012405 hex (Ver. 1.08 or later)	Directory Does Not Exist (FTP)	The directory specified for an FTP client communications instruction does not exist in the Controller or an incorrect path was specified.	<ul style="list-style-type: none"> The directory specified for an FTP client communications instruction does not exist in the Controller or an incorrect path was specified. 				√		page A-103

Event code	Event name	Meaning	Assumed cause	Level					Reference
				Maj	Prt	Min	Obs	Info	
54012406 hex (Ver. 1.08 or later)	FTP Server Connection Error	The destination FTP server that was specified for an FTP client communications instruction does not exist on the network or the specified FTP server is not operating.	<ul style="list-style-type: none"> The destination FTP server that was specified for an FTP client communications instruction does not exist on the network. The destination FTP server that was specified for an FTP client communications instruction is not operating. 				√		page A-103
54012407 hex (Ver. 1.08 or later)	Destination FTP Server Execution Failure	The destination FTP server for an FTP client communications instruction returned an error.	<ul style="list-style-type: none"> The destination FTP server for the FTP client communications instruction failed to execute the requested processing. 				√		page A-104
54012408 hex (Ver. 1.08 or later)	SD Memory Card Access Failed for FTP	SD Memory Card access from the FTP client failed.	<ul style="list-style-type: none"> An SD Memory Card is not inserted. The SD Memory Card was removed during execution of the FTP client communications instruction. The capacity of the SD Memory Card is insufficient. The SD Memory Card is write protected. 				√		page A-104
54012409 hex (Ver. 1.08 or later)	Specified File Does Not Exist	A file specified for an FTP client communications instruction does not exist.	<ul style="list-style-type: none"> A file specified for an FTP client communications instruction does not exist. 				√		page A-105
5401240A hex (Ver. 1.08 or later)	Specified File Is Write Protected	The data was not transferred because the FTP client communications instruction was set to not overwrite files with the same name.	<ul style="list-style-type: none"> The data was not transferred because the FTP client communications instruction was set to not overwrite files with the same name and a file with the specified file name already existed at the destination. 				√		page A-105
5401240B hex (Ver. 1.08 or later)	Failed To Delete Specified File	A file was not deleted after it was transferred with an FTP client communications instruction.	<ul style="list-style-type: none"> The FTP client communications instruction was set to delete files after they are transferred, but it was not possible to delete the specified file because it had a read-only attribute. It was not possible to delete the file specified for the FTP client communications instruction because it was in use by another application. 				√		page A-106
5401240C hex (Ver. 1.08 or later)	Specified File Access Failed	An FTP transfer for an FTP client communications instruction failed because file access failed.	<ul style="list-style-type: none"> The file specified for the FTP client communications instruction was in use by another application. The file or directory specified for the FTP client communications instruction to write is write protected. 				√		page A-107

Event code	Event name	Meaning	Assumed cause	Level					Reference
				Maj	Prt	Min	Obs	Info	
5401240D hex (Ver. 1.10 or later)	IP Address Setting Invalid	Instruction execution was not possible because there is an error between the IP address setting of the port specified in the instruction and the other port settings.	<ul style="list-style-type: none"> The network address of the port specified in the instruction is the same as the network address of another port. Both the port specified in the instruction and the other ports are set as unused ports. 				√		page A-108
54012C00 hex (Ver. 1.05 or later)	NX Message Error	An error response code was returned for an NX message.	<ul style="list-style-type: none"> Depends on the nature of the error. 				√		page A-108
54012C01 hex (Ver. 1.05 or later)	NX Message Resource Overflow	The maximum resources that you can use for NX message instructions at the same time was exceeded.	<ul style="list-style-type: none"> More than 32 NX message instructions were executed at the same time. 				√		page A-109
54012C02 hex (Ver. 1.05 or later)	NX Message Timeout	A timeout occurred during execution of an NX message.	<ul style="list-style-type: none"> The specified NX Unit does not exist. The NX message was closed because it timed out. Power to the remote Unit is OFF. Communications are stopped at the remote Unit. The communications cable connector is disconnected. The communications cable is broken. Noise 				√		page A-110
54012C03 hex (Ver. 1.05 or later)	Incorrect NX Message Length	The length of the NX message is not correct.	<ul style="list-style-type: none"> The size that is specified for WriteDat or Path is too long. 				√		page A-111
54012C05 hex (Ver. 1.05 or later)	NX Message EtherCAT Network Error	An error occurred in EtherCAT communications on the NX message path.	<ul style="list-style-type: none"> An error occurred in EtherCAT communications on the NX message path. 				√		page A-111
54012C06 hex (Ver. 1.05 or later)	External Restart Already Executed for Specified NX Units	A restart was already in execution from the Sysmac Studio when the instruction was executed.	<ul style="list-style-type: none"> A restart was already in execution from the Sysmac Studio when the instruction was executed. 				√		page A-112
54012C07 hex (Ver. 1.05 or later)	Unapplicable Unit Specified for Instruction	A slave that cannot be specified for the instruction was connected at the slave node address of the specified Unit.	<ul style="list-style-type: none"> A slave that cannot be specified for the instruction was connected to the slave node address of the specified Unit. 				√		page A-112
54012C08 hex (Ver. 1.10 or later)	Invalid Total Power ON Time Record	The total power ON time could not be read.	<ul style="list-style-type: none"> Non-volatile memory failure 				√		page A-113

Event code	Event name	Meaning	Assumed cause	Level					Reference
				Maj	Prt	Min	Obs	Info	
54013461 hex	Process Data Object Setting Missing	The PDO mapping is not correct.	<ul style="list-style-type: none"> The PDOs that are required for the motion control instruction are not mapped. The relevant instruction was executed for a device that does not have an object that supports the instruction. A motion control instruction that specifies phase Z (<code>_mcEncoderMark</code>) as the trigger conditions was executed for an axis that is mapped to an OMRON GX-EC02□□ EtherCAT Encoder slave. 				√		page A-114
54014800 hex (Ver. 1.12 or later)	Device Error Received	An error response from the device was received.	<ul style="list-style-type: none"> An error response from the device was received. 				√		page A-115
54014801 hex (Ver. 1.12 or later)	Specified Unit Does Not Exist	The specified Unit does not exist.	<ul style="list-style-type: none"> The IO-Link master is not connected to or mounted on the specified position. 				√		page A-115
54014802 hex (Ver. 1.12 or later)	Message Processing Limit Exceeded	An instruction cannot be executed because the IO-Link master is processing the message from another application.	<ul style="list-style-type: none"> An instruction cannot be executed because the IO-Link master is processing the message from another application (an instruction execution or a tool connection). 				√		page A-116
54014803 hex (Ver. 1.12 or later)	Specified Unit Status Error	The specified Unit is not in a condition to receive messages.	<ul style="list-style-type: none"> The specified Unit is not in a condition to receive messages. 				√		page A-116
54014804 hex (Ver. 1.12 or later)	Too Many Simultaneous Instruction Executions	The number of instructions that can be simultaneously executed was exceeded.	<ul style="list-style-type: none"> More than 32 NX message instructions and EtherCAT communications instructions were executed at the same time. 				√		page A-117
54014805 hex (Ver. 1.12 or later)	Communications Timeout	A timeout occurred in communications.	<ul style="list-style-type: none"> The communications timeout time is shorter than the message response time. The cable for EtherCAT or for IO-Link is broken. Noise Device failure 				√		page A-117
54014806 hex (Ver. 1.12 or later)	Invalid Mode	The specified IO-Link master port is not the IO-Link mode.	<ul style="list-style-type: none"> The specified IO-Link master port is not the IO-Link mode. 				√		page A-118
54014807 hex (Ver. 1.12 or later)	I/O Power OFF Status	The I/O power is not supplied to the specified IO-Link master port.	<ul style="list-style-type: none"> The I/O power is not supplied to the specified IO-Link master port. 				√		page A-118
54014808 hex (Ver. 1.12 or later)	Verification Error	The specified IO-Link master port had a verification error or a communications error.	<ul style="list-style-type: none"> The specified IO-Link master port had a verification error or a communications error. 				√		page A-119

Event code	Event name	Meaning	Assumed cause	Level					Reference
				Maj	Prt	Min	Obs	Info	
54015420 hex	Electronic Gear Ratio Numerator Setting Out of Range	The parameter specified for the <i>RatioNumerator</i> input variable to a motion control instruction is out of range.	<ul style="list-style-type: none"> Instruction input parameter exceeded the valid range of the input variable. 				√		page A-120
54015421 hex	Electronic Gear Ratio Denominator Setting Out of Range	The parameter specified for the <i>RatioDenominator</i> input variable to a motion control instruction is out of range.	<ul style="list-style-type: none"> Instruction input parameter exceeded the valid range of the input variable. 				√		page A-120
54015422 hex	Target Velocity Setting Out of Range	The parameter specified for the <i>Velocity</i> input variable to a motion control instruction is out of range.	<ul style="list-style-type: none"> Instruction input parameter exceeded the valid range of the input variable. 				√		page A-121
54015423 hex	Acceleration Setting Out of Range	The parameter specified for the <i>Acceleration</i> input variable to a motion control instruction is out of range.	<ul style="list-style-type: none"> Instruction input parameter exceeded the valid range of the input variable. 				√		page A-121
54015424 hex	Deceleration Setting Out of Range	The parameter specified for the <i>Deceleration</i> input variable to a motion control instruction is out of range.	<ul style="list-style-type: none"> Instruction input parameter exceeded the valid range of the input variable. 				√		page A-122
54015425 hex	Jerk Setting Out of Range	The parameter specified for the <i>Jerk</i> input variable to a motion control instruction is out of range.	<ul style="list-style-type: none"> Instruction input parameter exceeded the valid range of the input variable. 				√		page A-122
54015427 hex	Torque Ramp Setting Out of Range	The parameter specified for the <i>TorqueRamp</i> input variable to a motion control instruction is out of range.	<ul style="list-style-type: none"> Instruction input parameter exceeded the valid range of the input variable. 				√		page A-123
54015428 hex	Master Coefficient Scaling Out of Range	The parameter specified for the <i>MasterScaling</i> input variable to a motion control instruction is out of range.	<ul style="list-style-type: none"> Instruction input parameter exceeded the valid range of the input variable. 				√		page A-123
54015429 hex	Slave Coefficient Scaling Out of Range	The parameter specified for the <i>SlaveScaling</i> input variable to a motion control instruction is out of range.	<ul style="list-style-type: none"> Instruction input parameter exceeded the valid range of the input variable. 				√		page A-124
5401542A hex	Feeding Velocity Setting Out of Range	The parameter specified for the <i>FeedVelocity</i> input variable to a motion control instruction is out of range.	<ul style="list-style-type: none"> The Feed Velocity (input variable <i>FeedVelocity</i>) is still at the default (0). 				√		page A-124
5401542B hex	Buffer Mode Selection Out of Range	The parameter specified for the <i>BufferMode</i> input variable to a motion control instruction is out of range.	<ul style="list-style-type: none"> Instruction input parameter exceeded the valid range of the input variable. 				√		page A-125
5401542C hex	Coordinate System Selection Out of Range	The parameter specified for the <i>CoordSystem</i> input variable to a motion control instruction is out of range.	<ul style="list-style-type: none"> Instruction input parameter exceeded the valid range of the input variable. 				√		page A-125

Event code	Event name	Meaning	Assumed cause	Level					Reference
				Maj	Prt	Min	Obs	Info	
5401542D hex	Circular Interpolation Mode Selection Out of Range	The parameter specified for the <i>CircMode</i> input variable to a motion control instruction is out of range.	<ul style="list-style-type: none"> Instruction input parameter exceeded the valid range of the input variable. 				√		page A-126
5401542E hex	Direction Selection Out of Range	The parameter specified for the <i>Direction</i> input variable to a motion control instruction is out of range.	<ul style="list-style-type: none"> Instruction input parameter exceeded the valid range of the input variable. 				√		page A-126
5401542F hex	Path Selection Out of Range	The parameter specified for the <i>PathChoice</i> input variable to a motion control instruction is out of range.	<ul style="list-style-type: none"> Instruction input parameter exceeded the valid range of the input variable. 				√		page A-127
54015430 hex	Position Type Selection Out of Range	The parameter specified for the <i>ReferenceType</i> input variable to a motion control instruction is out of range.	<ul style="list-style-type: none"> Instruction input parameter exceeded the valid range of the input variable. 				√		page A-127
54015431 hex	Travel Mode Selection Out of Range	The parameter specified for the <i>MoveMode</i> input variable to a motion control instruction is out of range.	<ul style="list-style-type: none"> Instruction input parameter exceeded the valid range of the input variable. 				√		page A-128
54015432 hex	Transition Mode Selection Out of Range	The parameter specified for the <i>TransitionMode</i> input variable to a motion control instruction is out of range.	<ul style="list-style-type: none"> Instruction input parameter exceeded the valid range of the input variable. <i>_mcAborting</i> or <i>_mcBuffered</i> was specified for <i>BufferMode</i> and <i>_mcTMC-CornerSuperimposed</i> was specified for <i>TransitionMode</i>. 				√		page A-128
54015433 hex	Continue Method Selection Out of Range	The value of the reserved input variable <i>Continuous</i> to a motion control instruction changed.	<ul style="list-style-type: none"> The value of the reserved input variable <i>Continuous</i> changed. 				√		page A-129
54015434 hex	Combine Mode Selection Out of Range	The parameter specified for the <i>CombineMode</i> input variable to a motion control instruction is out of range.	<ul style="list-style-type: none"> Instruction input parameter exceeded the valid range of the input variable. 				√		page A-129
54015435 hex	Synchronization Start Condition Selection Out of Range	The parameter specified for the <i>LinkOption</i> input variable to a motion control instruction is out of range.	<ul style="list-style-type: none"> Instruction input parameter exceeded the valid range of the input variable. 				√		page A-130
54015436 hex	Master and Slave Defined as Same Axis	The same axis is specified for the <i>Master</i> and <i>Slave</i> input variables to a motion control instruction.	<ul style="list-style-type: none"> The parameter is the same for the <i>Master</i> and <i>Slave</i> input variables to the instruction. 				√		page A-130
54015437 hex	Master and Auxiliary Defined as Same Axis	The same axis is specified for the <i>Master</i> and <i>Auxiliary</i> input variables to a motion control instruction.	<ul style="list-style-type: none"> The parameter is the same for the <i>Master</i> and <i>Auxiliary</i> input variables to the instruction. 				√		page A-131

Event code	Event name	Meaning	Assumed cause	Level					Reference
				Maj	Prt	Min	Obs	Info	
54015438 hex	Master/Slave Axis Numbers Not in Ascending Order	The axis numbers specified for the <i>Master</i> and <i>Slave</i> input variables to a motion control instruction are not in ascending order.	<ul style="list-style-type: none"> The parameters for the <i>Master</i> and <i>Slave</i> input variables to the instruction were not in ascending order when <i>_mclatest-Command</i> was specified for the <i>ReferenceType</i> input variable to the instruction. 				√		page A-131
54015439 hex	Incorrect Cam Table Specification	The parameter specified for the <i>CamTable</i> input variable to a motion control instruction is out of range.	<ul style="list-style-type: none"> Something other than a cam data variable was specified for the <i>CamTable</i> input variable to the instruction. 				√		page A-132
5401543A hex	Synchronization Stopped	A synchronized control motion control instruction was executed, but conditions required for execution were not met.	<ul style="list-style-type: none"> The MC_CamOut (End Cam Operation) instruction was executed even though the MC_CamIn (Start Cam Operation) instruction is not being executed. The MC_GearOut (End Gear Operation) instruction was executed even though the MC_GearIn (Start Gear Operation) or the MC_GearInPos (Positioning Gear Operation) instruction is not being executed. The MC_Phasing (Shift Master Axis Phase) instruction was executed even though the MC_CamIn (Start Cam Operation), MC_GearIn (Start Gear Operation), MC_GearInPos (Start Gear Operation), or MC_MoveLink (Synchronous Positioning) instruction is not being executed. 				√		page A-133
5401543B hex	Motion Control Instruction Re-execution Disabled	An attempt was made to re-execute a motion control instruction that cannot be re-executed.	<ul style="list-style-type: none"> A motion control instruction that cannot be re-executed was re-executed. 				√		page A-134
5401543C hex	Motion Control Instruction Multi-execution Disabled	Multiple functions that cannot be executed simultaneously were executed for the same target (MC common, axis, or axes group).	<ul style="list-style-type: none"> Multiple functions that cannot be executed simultaneously were executed for the same target (MC common or axis). 				√		page A-134
5401543D hex	Instruction Not Allowed for Encoder Axis Type	An operation instruction was executed for an encoder axis.	<ul style="list-style-type: none"> An operation instruction was executed for an encoder axis. 				√		page A-135

Event code	Event name	Meaning	Assumed cause	Level					Reference
				Maj	Prt	Min	Obs	Info	
5401543E hex	Instruction Cannot Be Executed during Multi-axes Coordinated Control	<ul style="list-style-type: none"> An operation instruction was executed for an axis or an axes group that was in a coordinated multi-axes motion. A robot instruction that you cannot use for an axes group in a <i>GroupEnable</i> state was executed. 	<ul style="list-style-type: none"> An operation instruction was executed for an axis or an axes group that was in a coordinated multi-axes motion. The MC_SetKinTransform instruction was executed for an axes group in a <i>GroupEnable</i> state. 				√		page A-135
5401543F hex	Multi-axes Coordinated Control Instruction Executed for Disabled Axes Group	A multi-axes coordinated control instruction was executed for an axes group that was in the Axes Group Disabled state.	<ul style="list-style-type: none"> A multi-axes coordinated control instruction was executed for an axes group that was in the Axes Group Disabled state. One of the following instructions was executed for an axes group that was in a <i>GroupDisable</i> state. <ul style="list-style-type: none"> MC_MoveTimeAbsolute MC_SyncLinearConveyor MC_SyncOut MC_RobotJog 				√		page A-136
54015440 hex	Axes Group Cannot Be Enabled	Execution of the MC_GroupEnable (Enable Axes Group) instruction failed.	<ul style="list-style-type: none"> When the MC_GroupEnable (Enable Axes Group) instruction was executed, there was a composition axis that was not stopped. When the MC_GroupEnable (Enable Axes Group) instruction was executed, there was a composition axis for which the MC_TouchProbe (Enable External Latch) instruction was being executed. 				√		page A-137
54015441 hex	Impossible Axis Operation Specified when the Servo is OFF	An operation instruction was executed for an axis for which the Servo is OFF.	<ul style="list-style-type: none"> An operation instruction was executed for an axis for which the Servo is OFF. Home was preset with the MC_Home or MC_Home-WithParameter instruction for an axis for which EtherCAT process data communications are not established. 				√		page A-138
54015442 hex	Composition Axis Stopped Error	A motion instruction was executed for an axes group while the MC_Stop instruction was being executed for a composition axis.	A motion instruction was executed for an axes group while the MC_Stop instruction was being executed for a composition axis.				√		page A-139

Event code	Event name	Meaning	Assumed cause	Level					Reference
				Maj	Prt	Min	Obs	Info	
54015443 hex	Motion Control Instruction Multi-execution Buffer Limit Exceeded	The number of motion control instructions that is buffered for Buffered or Blending Buffer Modes exceeded the buffer limit.	<ul style="list-style-type: none"> An axis instruction was executed when there was already a current instruction and a buffered instruction for the same axis. An axes group instruction was executed when there was already eight current instructions and buffered instructions for the same axis. 				√		page A-139
54015444 hex	Insufficient Travel Distance	The specified motion cannot be executed for the deceleration rate or acceleration rate that was specified for multi-execution or re-execution of a positioning instruction.	<ul style="list-style-type: none"> Stopping at the target position was not possible for the specified acceleration/deceleration rate for multi-execution or re-execution of a positioning instruction when the Acceleration/Deceleration Over parameter was set to generate a minor fault and stop. 				√		page A-140
54015445 hex	Insufficient Travel Distance to Achieve Blending Transit Velocity	There is not sufficient travel distance to accelerate or decelerate to the transit velocity.	<ul style="list-style-type: none"> There was not sufficient travel distance to accelerate the current command to the transit velocity when the Acceleration/Deceleration Over parameter was set to generate a minor fault and stop. 				√		page A-141
54015446 hex	Move Link Constant Velocity Insufficient Travel Distance	The constant-velocity travel distance of the master axis is less than zero.	<ul style="list-style-type: none"> The constant velocity travel distance of the master axis is below 0 for the MC_MoveLink (Synchronous Positioning) instruction. 				√		page A-141
54015447 hex	Positioning Gear Operation Insufficient Target Velocity	For the MC_GearInPos (Positioning Gear Operation) instruction, the target velocity of the slave axis is too small to achieve the required velocity.	<ul style="list-style-type: none"> For the MC_GearInPos (Positioning Gear Operation) instruction, the value of the <i>Velocity</i> (Target Velocity) input variable is smaller than the master axis velocity multiplied by the gear ratio when the instruction was executed. 				√		page A-142
54015448 hex	Same Start Point and End Point for Circular Interpolation	The start point and end point were the same when the radius method was specified for the MC_MoveCircular2D (Circular 2D Interpolation) instruction. Or, the start point, end point, and border point were the same when the border point method was specified.	<ul style="list-style-type: none"> The start point and end point were the same when the radius method was specified for the MC_MoveCircular2D (Circular 2D Interpolation) instruction. The start point, end point, and border point were the same when the border point method was specified for the MC_MoveCircular2D (Circular 2D Interpolation) instruction. 				√		page A-142

Event code	Event name	Meaning	Assumed cause	Level					Reference
				Maj	Prt	Min	Obs	Info	
54015449 hex	Circular Interpolation Center Specification Position Out of Range	The position specified for the center point exceeded the allowed range when the center method was specified for the MC_MoveCircular2D (Circular 2D Interpolation) instruction.	<ul style="list-style-type: none"> The difference between the distance from the start point to the center point and the distance between the end point to the center point exceeded the permitted value specified for the correction allowance ratio in the axes group settings when the center designation method was specified for the MC_MoveCircular2D (Circular 2D Interpolation) instruction. 				√		page A-143
5401544A hex	Instruction Execution Error Caused by Count Mode Setting	An instruction that cannot be used when the Count Mode is set to Rotary Mode was executed for an axis that was set to Rotary Mode.	<ul style="list-style-type: none"> An instruction that cannot be used when the Count Mode is set to Rotary Mode was executed for an axis that was set to Rotary Mode. 				√		page A-143
5401544C hex	Parameter Selection Out of Range	The parameter specified for the <i>ParameterNumber</i> input variable to a motion control instruction is out of range.	<ul style="list-style-type: none"> Instruction input parameter exceeded the valid range of the input variable. 				√		page A-144
5401544D hex	Stop Method Selection Out of Range	The parameter specified for the <i>StopMode</i> input variable to a motion control instruction is out of range.	<ul style="list-style-type: none"> Instruction input parameter exceeded the valid range of the input variable. 				√		page A-144
5401544E hex	Latch ID Selection Out of Range for Trigger Input Condition	The parameter specified for the <i>TriggerInput::LatchID</i> input variable to a motion control instruction is out of range.	<ul style="list-style-type: none"> Instruction input parameter exceeded the valid range of the input variable. 				√		page A-145
5401544F hex	Setting Out of Range for Writing MC Setting	The parameter specified for the <i>SettingValue</i> input variable to a motion control instruction is out of range.	<ul style="list-style-type: none"> Instruction input parameter exceeded the valid range of the input variable. The parameter specification and the data type of the setting value do not agree. 				√		page A-145
54015450 hex	Trigger Input Condition Mode Selection Out of Range	The parameter specified for the <i>TriggerInput::Mode</i> input variable to a motion control instruction is out of range.	<ul style="list-style-type: none"> Instruction input parameter exceeded the valid range of the input variable. 				√		page A-146
54015451 hex	Drive Trigger Signal Selection Out of Range for Trigger Input Condition	The parameter specified for the <i>TriggerInput::InputDrive</i> input variable to a motion control instruction is out of range.	<ul style="list-style-type: none"> Instruction input parameter exceeded the valid range of the input variable. 				√		page A-146
54015453 hex	Motion Control Instruction Re-execution Disabled (Axis Specification)	An attempt was made to change the parameter for the <i>Axis</i> input variable when re-executing a motion control instruction. (This input variable cannot be changed when re-executing an instruction.)	<ul style="list-style-type: none"> A parameter for an input variable that cannot be changed for re-execution was changed. 				√		page A-147

Event code	Event name	Meaning	Assumed cause	Level					Reference
				Maj	Prt	Min	Obs	Info	
54015454 hex	Motion Control Instruction Re-execution Disabled (Buffer Mode Selection)	An attempt was made to change the parameter for the <i>BufferMode</i> input variable when re-executing a motion control instruction. (This input variable cannot be changed when re-executing an instruction.)	<ul style="list-style-type: none"> A parameter for an input variable that cannot be changed for re-execution was changed. 				√		page A-147
54015455 hex	Motion Control Instruction Re-execution Disabled (Direction Selection)	An attempt was made to change the parameter for the <i>Direction</i> input variable when re-executing a motion control instruction. (This input variable cannot be changed when re-executing an instruction.)	<ul style="list-style-type: none"> An input variable that cannot be changed for re-execution was changed. 				√		page A-148
54015456 hex	Motion Control Instruction Re-execution Disabled (Execution Mode)	An attempt was made to change the parameter for the <i>Periodic</i> input variable when re-executing a motion control instruction. (This input variable cannot be changed when re-executing an instruction.)	<ul style="list-style-type: none"> A parameter for an input variable that cannot be changed for re-execution was changed. 				√		page A-148
54015457 hex	Motion Control Instruction Re-execution Disabled (Axes Group Specification)	An attempt was made to change the parameter for the <i>AxesGroup</i> input variable when re-executing a motion control instruction. (This input variable cannot be changed when re-executing an instruction.)	<ul style="list-style-type: none"> A parameter for an input variable that cannot be changed for re-execution was changed. 				√		page A-149
54015458 hex	Motion Control Instruction Re-execution Disabled (Jerk Setting)	An attempt was made to change the parameter for the <i>Jerk</i> input variable when re-executing a motion control instruction. (This input variable cannot be changed when re-executing an instruction.)	<ul style="list-style-type: none"> A parameter for an input variable that cannot be changed for re-execution was changed. 				√		page A-149
54015459 hex	Motion Control Instruction Re-execution Disabled (Master Axis)	An attempt was made to change the parameter for the <i>Master</i> input variable when re-executing a motion control instruction. (This input variable cannot be changed when re-executing an instruction.)	<ul style="list-style-type: none"> A parameter for an input variable that cannot be changed for re-execution was changed. 				√		page A-150
5401545A hex	Motion Control Instruction Re-execution Disabled (MasterOffset)	An attempt was made to change the parameter for the <i>MasterOffset</i> input variable when re-executing a motion control instruction. (This input variable cannot be changed when re-executing an instruction.)	<ul style="list-style-type: none"> A parameter for an input variable that cannot be changed for re-execution was changed. 				√		page A-150

Event code	Event name	Meaning	Assumed cause	Level					Reference
				Maj	Prt	Min	Obs	Info	
5401545B hex	Motion Control Instruction Re-execution Disabled (MasterScaling)	An attempt was made to change the parameter for the <i>MasterScaling</i> input variable when re-executing a motion control instruction. (This input variable cannot be changed when re-executing an instruction.)	<ul style="list-style-type: none"> A parameter for an input variable that cannot be changed for re-execution was changed. 				√		page A-151
5401545C hex	Motion Control Instruction Re-execution Disabled (MasterStartDistance)	An attempt was made to change the parameter for the <i>MasterStartDistance</i> input variable when re-executing a motion control instruction. (This input variable cannot be changed when re-executing an instruction.)	<ul style="list-style-type: none"> A parameter for an input variable that cannot be changed for re-execution was changed. 				√		page A-151
5401545D hex	Motion Control Instruction Re-execution Disabled (Continuous)	An attempt was made to change the parameter for the <i>Continuous</i> input variable when re-executing a motion control instruction. (This input variable cannot be changed when re-executing an instruction.)	<ul style="list-style-type: none"> A parameter for an input variable that cannot be changed for re-execution was changed. 				√		page A-152
5401545E hex	Motion Control Instruction Re-execution Disabled (MoveMode)	An attempt was made to change the parameter for the <i>MoveMode</i> input variable when re-executing a motion control instruction. (This input variable cannot be changed when re-executing an instruction.)	<ul style="list-style-type: none"> A parameter for an input variable that cannot be changed for re-execution was changed. 				√		page A-152
5401545F hex	Illegal Auxiliary Axis Specification	The axis specified for the <i>Auxiliary</i> input variable to a motion control instruction does not exist.	<ul style="list-style-type: none"> An axis does not exist for the variable specified for the <i>Auxiliary</i> input variable to the instruction. 				√		page A-153
54015460 hex	Illegal Axis Specification	The axis specified for the <i>Axis</i> input variable to a motion control instruction does not exist.	<ul style="list-style-type: none"> An axis does not exist for the variable specified for the <i>Axis</i> input variable to the instruction. 				√		page A-153
54015461 hex	Illegal Axes Group Specification	The axes group specified for the <i>AxesGroup</i> input variable to a motion control instruction does not exist or is not a used group.	<ul style="list-style-type: none"> An axes group does not exist for the variable specified for the <i>AxesGroup</i> input variable to the instruction. The axes group specified for the <i>AxesGroup</i> input variable to the instruction is not specified as a used group. 				√		page A-154

Event code	Event name	Meaning	Assumed cause	Level					Reference
				Maj	Prt	Min	Obs	Info	
54015462 hex	Illegal Master Axis Specification	The axis that is specified for the <i>Master</i> input variable to a motion control instruction is not correct.	<ul style="list-style-type: none"> An axis does not exist for the variable specified for the <i>Master</i> input variable to the instruction. The axis that was specified for the <i>Master</i> input variable to the MC_Phasing (Shift Master Axis Phase) instruction is not the master axis for syncing. The master axis and a slave axis are not assigned to the same task. 				√		page A-155
54015463 hex	Motion Control Instruction Re-execution Disabled (SlaveOffset)	An attempt was made to change the <i>SlaveOffset</i> input variable when re-executing a motion control instruction. (This input variable cannot be changed when re-executing an instruction.)	<ul style="list-style-type: none"> A parameter for an input variable that cannot be changed for re-execution was changed. 				√		page A-156
54015464 hex	Motion Control Instruction Re-execution Disabled (SlaveScaling)	An attempt was made to change the <i>SlaveScaling</i> input variable when re-executing a motion control instruction. (This input variable cannot be changed when re-executing an instruction.)	<ul style="list-style-type: none"> A parameter for an input variable that cannot be changed for re-execution was changed. 				√		page A-156
54015465 hex	Motion Control Instruction Re-execution Disabled (StartPosition)	An attempt was made to change the <i>StartPosition</i> input variable when re-executing a motion control instruction. (This input variable cannot be changed when re-executing an instruction.)	<ul style="list-style-type: none"> A parameter for an input variable that cannot be changed for re-execution was changed. 				√		page A-157
54015466 hex	Instruction Execution Error with Undefined Home	High-speed homing or an interpolation instruction was executed when home was undefined.	<ul style="list-style-type: none"> High-speed homing was executed when home was undefined. An interpolation instruction was executed for an axes group that includes an axis with no defined home. One of the following robot instructions was executed for an axes group that includes a logical axis with no defined home. <ul style="list-style-type: none"> MC_SetKinTransform MC_MoveTimeAbsolute MC_SyncLinearConveyor MC_SyncOut MC_GroupMon MC_RobotJog 				√		page A-158

Event code	Event name	Meaning	Assumed cause	Level					Reference
				Maj	Prt	Min	Obs	Info	
54015467 hex	Motion Control Instruction Re-execution Disabled (Position Type)	An attempt was made to change the <i>Reference-Type</i> input variable when re-executing a motion control instruction. (This input variable cannot be changed when re-executing an instruction.)	<ul style="list-style-type: none"> A parameter for an input variable that cannot be changed for re-execution was changed. 				√		page A-159
54015468 hex	Unused Axis Specification for Master Axis	The master axis specified for a motion control instruction is an unused axis.	<ul style="list-style-type: none"> The master axis specified for a motion control instruction is an unused axis. 				√		page A-159
54015469 hex	First Position Setting Out of Range	The parameter specified for the <i>FirstPosition</i> input variable to a motion control instruction is out of range.	<ul style="list-style-type: none"> Instruction input parameter exceeded the valid range of the input variable. 				√		page A-160
5401546A hex	Last Position Setting Out of Range	The parameter specified for the <i>LastPosition</i> input variable to a motion control instruction is out of range.	<ul style="list-style-type: none"> Instruction input parameter exceeded the valid range of the input variable. 				√		page A-160
5401546B hex	Illegal First/Last Position Size Relationship (Linear Mode)	The parameter specified for the <i>LastPosition</i> input variable to a motion control instruction is smaller than the parameter specified for the <i>FirstPosition</i> input variable.	<ul style="list-style-type: none"> The value of the <i>LastPosition</i> input parameter is less than the value of the <i>FirstPosition</i> input variable for the instruction when the Count Mode is set to Linear Mode. 				√		page A-161
5401546C hex	Master Sync Start Position Setting Out of Range	The parameter specified for the <i>MasterSyncPosition</i> input variable to a motion control instruction is out of range.	<ul style="list-style-type: none"> Instruction input parameter exceeded the valid range of the input variable. 				√		page A-161
5401546D hex	Slave Sync Start Position Setting Out of Range	The parameter specified for the <i>SlaveSyncPosition</i> input variable to a motion control instruction is out of range.	<ul style="list-style-type: none"> Instruction input parameter exceeded the valid range of the input variable. 				√		page A-162
5401546E hex	Duplicate Latch ID for Trigger Input Condition	The same latch ID was specified for more than one motion control instruction.	<ul style="list-style-type: none"> The same latch ID is used simultaneously for more than one of the following instructions: <i>MC_TouchProbe</i> (Enable External Latch) instruction, <i>MC_MoveLink</i> (Synchronous Positioning) instruction, and <i>MC_MoveFeed</i> (Interrupt Feeding) instruction. The <i>MC_AbortTrigger</i> (Disable External Latch) instruction was executed to cancel a latch that was used by an instruction other than the <i>MC_TouchProbe</i> (Enable External Latch) instruction. 				√		page A-162
5401546F hex	Jerk Override Factor Out of Range	The parameter specified for the <i>JerkFactor</i> input variable to a motion control instruction is out of range.	<ul style="list-style-type: none"> Instruction input parameter exceeded the valid range of the input variable. 				√		page A-163

Event code	Event name	Meaning	Assumed cause	Level					Reference
				Maj	Prt	Min	Obs	Info	
54015470 hex	Acceleration/Deceleration Override Factor Out of Range	The parameter specified for the <i>AccFactor</i> input variable to a motion control instruction is out of range.	<ul style="list-style-type: none"> Instruction input parameter exceeded the valid range of the input variable. 				√		page A-163
54015471 hex	First Position Method Specification Out of Range	The parameter specified for the <i>StartMode</i> input variable to a motion control instruction is out of range.	<ul style="list-style-type: none"> Instruction input parameter exceeded the valid range of the input variable. 				√		page A-164
54015472 hex	Motion Control Instruction Re-execution Disabled (First Position Method)	An attempt was made to change the <i>StartMode</i> input variable when re-executing a motion control instruction. (This input variable cannot be changed when re-executing an instruction.)	<ul style="list-style-type: none"> A parameter for an input variable that cannot be changed for re-execution was changed. 				√		page A-164
54015474 hex	Unused Axis Specification for Auxiliary Axis	The axis specified for the <i>Auxiliary</i> input variable to a motion control instruction is an unused axis.	<ul style="list-style-type: none"> The axis specified for the <i>Auxiliary</i> input variable to the instruction is an unused axis. 				√		page A-165
54015475 hex	Position Gear Value Error	Synchronized motion is not possible for the velocity, acceleration rate, and deceleration rate that were input to a motion control instruction.	<ul style="list-style-type: none"> The specified synchronized motion cannot be performed at the velocity, acceleration rate, or deceleration rate that is input to the instruction. 				√		page A-165
54015476 hex	Position Gear Master Axis Zero Velocity	The velocity of the master axis was zero when a motion control instruction was started.	<ul style="list-style-type: none"> The velocity of the master axis was 0 when the instruction was started. 				√		page A-166
54015478 hex	Target Position Setting Out of Range	The parameter specified for the <i>Position</i> input variable to a motion control instruction is out of range.	<ul style="list-style-type: none"> Instruction input parameter exceeded the valid range of the input variable. The target position of a Rotary Mode axis is not within the ring setting range. 				√		page A-166
54015479 hex	Travel Distance Out of Range	The parameter that was specified for the <i>Distance</i> input variable to a motion control instruction is out of range or the target position with the value of <i>Distance</i> added is out of range.	<ul style="list-style-type: none"> The absolute value of the instruction input parameter exceeded the range of 40-bit data when it is converted to pulses. For a Linear Mode axis, the target position with the travel distance added exceeded signed 40-bit data when the absolute value is converted to pulses. 				√		page A-167
5401547A hex	Cam Table Start Point Setting Out of Range	The parameter specified for the <i>StartPosition</i> input variable to a motion control instruction is out of range.	<ul style="list-style-type: none"> Instruction input parameter exceeded the valid range of the input variable. 				√		page A-167
5401547B hex	Cam Master Axis Following First Position Setting Out of Range	The parameter specified for the <i>MasterStartDistance</i> input variable to a motion control instruction is out of range.	<ul style="list-style-type: none"> Instruction input parameter exceeded the valid range of the input variable. 				√		page A-168

Event code	Event name	Meaning	Assumed cause	Level					Reference
				Maj	Prt	Min	Obs	Info	
5401547C hex	Circular Interpolation Radius Setting Error	It was not possible to create a circular path for the specified radius when the radius method was specified for the MC_MoveCircular2D (Circular 2D Interpolation) instruction.	<ul style="list-style-type: none"> For the MC_MoveCircular2D (Circular 2D Interpolation) instruction, it was not possible to create a circular path for the specified radius when the radius method was specified for circular interpolation. 				√		page A-168
5401547D hex	Circular Interpolation Radius Overflow	For the MC_MoveCircular2D (Circular 2D Interpolation) instruction, the radius of the circle exceeded the maximum value for the border point or center specification method.	<ul style="list-style-type: none"> For the MC_MoveCircular2D (Circular 2D Interpolation) instruction, the radius of the circle exceeded 40-bit data when it is converted to pulses for the border point or center specification method. 				√		page A-169
5401547E hex	Circular Interpolation Setting Out of Range	The parameter specified for the <i>CircAxes</i> input variable to a motion control instruction is out of range.	<ul style="list-style-type: none"> Instruction input parameter exceeded the valid range of the input variable. The axes that were specified in <i>CircAxes</i> are not included in the composition axes in the Axes Group Settings. The same axis was specified for both axes of <i>CircAxes</i>. 				√		page A-170
5401547F hex	Auxiliary/Slave Axis Numbers Not in Ascending Order	The values of the parameters for the <i>Auxiliary</i> and <i>Slave</i> input variables to a motion control instruction are not in ascending order.	<ul style="list-style-type: none"> The parameters for the <i>Auxiliary</i> and <i>Slave</i> input variables to the instruction are not in ascending order. 				√		page A-170
54015480 hex	Cam Table Property Ascending Data Error at Update	A phase that was not in ascending order was found during calculating the number of valid data. Or, after calculations, the number of valid data is 0.	<ul style="list-style-type: none"> A phase that was not in ascending order was found when calculating the number of valid data. After calculations, the number of valid data is 0. 				√		page A-171
54015481 hex	MC_WriteTarget Out of Range	The parameter specified for the <i>Target</i> input variable to a motion control instruction is out of range.	<ul style="list-style-type: none"> Instruction input parameter exceeded the valid range of the input variable. 				√		page A-171
54015482 hex	Master Travel Distance Specification Out of Range	The parameter specified for the <i>MasterDistance</i> input variable to a motion control instruction is out of range.	<ul style="list-style-type: none"> Instruction input parameter exceeded the valid range of the input variable. 				√		page A-172
54015483 hex	Master Distance in Acceleration Specification Out of Range	The parameter specified for the <i>MasterDistance-ACC</i> input variable to a motion control instruction is out of range.	<ul style="list-style-type: none"> Instruction input parameter exceeded the valid range of the input variable. 				√		page A-172
54015484 hex	Master Distance in Deceleration Specification Out of Range	The parameter specified for the <i>MasterDistance-DEC</i> input variable to a motion control instruction is out of range.	<ul style="list-style-type: none"> Instruction input parameter exceeded the valid range of the input variable. 				√		page A-173

Event code	Event name	Meaning	Assumed cause	Level					Reference
				Maj	Prt	Min	Obs	Info	
54015487 hex	Execution Mode Selection Out of Range	The parameter specified for the <i>ExecutionMode</i> input variable to a motion control instruction is out of range.	<ul style="list-style-type: none"> Instruction input parameter exceeded the valid range of the input variable. 				√		page A-173
54015488 hex	Permitted Following Error Out of Range	The parameter specified for the <i>PermittedDeviation</i> input variable to a motion control instruction is out of range.	<ul style="list-style-type: none"> Instruction input parameter exceeded the valid range of the input variable. 				√		page A-174
54015489 hex	Border Point/Center Position/Radius Specification Out of Range	The parameter specified for the <i>AuxPoint</i> input variable to a motion control instruction is out of range.	<ul style="list-style-type: none"> The value of <i>AuxPoint</i> exceeded signed 40-bit data when converted to pulses for the border point or center specification method. For a radius specifications, the absolute value of <i>AuxPoint[0]</i> exceeded 40-bit data when it is converted to pulses. 				√		page A-174
5401548A hex	End Point Specification Out of Range	The parameter specified for the <i>EndPoint</i> input variable to a motion control instruction is out of range.	<ul style="list-style-type: none"> The instruction input parameter exceeded the range of signed 40-bit data when it is converted to pulses. 				√		page A-175
5401548B hex	Slave Travel Distance Specification Out of Range	The parameter specified for the <i>SlaveDistance</i> input variable to a motion control instruction is out of range.	<ul style="list-style-type: none"> The instruction input parameter exceeded the range of 40-bit data when it is converted to pulses. 				√		page A-175
5401548C hex	Phase Shift Amount Out of Range	The parameter specified for the <i>PhaseShift</i> input variable to a motion control instruction is out of range.	<ul style="list-style-type: none"> The absolute value of the instruction input parameter exceeded the range of 40-bit data when it is converted to pulses. 				√		page A-176
5401548D hex	Feeding Distance Out of Range	The parameter specified for the <i>FeedDistance</i> input variable to a motion control instruction is out of range.	<ul style="list-style-type: none"> The absolute value of the instruction input parameter exceeded the range of 40-bit data when it is converted to pulses. 				√		page A-176
5401548E hex	Auxiliary and Slave Defined as Same Axis	The same axis was specified for the <i>Auxiliary</i> and <i>Slave</i> input variables to a motion control instruction.	<ul style="list-style-type: none"> The parameter is the same for the <i>Auxiliary</i> and <i>Slave</i> input variables to the instruction. 				√		page A-177
5401548F hex	Relative Position Selection Out of Range	The parameter specified for the <i>Relative</i> input variable to a motion control instruction is out of range.	<ul style="list-style-type: none"> Instruction input parameter exceeded the valid range of the input variable. 				√		page A-177
54015490 hex	Cam Transition Specification Out of Range	The parameter specified for the <i>CamTransition</i> input variable to a motion control instruction is out of range.	<ul style="list-style-type: none"> Instruction input parameter exceeded the valid range of the input variable. 				√		page A-178
54015491 hex	Synchronized Control End Mode Selection Out of Range	The parameter specified for the <i>OutMode</i> input variable to a motion control instruction is out of range.	<ul style="list-style-type: none"> Instruction input parameter exceeded the valid range of the input variable. 				√		page A-178

Event code	Event name	Meaning	Assumed cause	Level					Reference
				Maj	Prt	Min	Obs	Info	
54015492 hex	Enable External Latch Instruction Execution Disabled	<i>_mclImmediateStop</i> was specified for the <i>Stop-Mode</i> input variable when the MC_TouchProbe (Enable External Latch) instruction was executed in Drive Mode for an encoder axis.	<ul style="list-style-type: none"> <i>_mclImmediateStop</i> was specified for the <i>Stop-Mode</i> input variable when the MC_TouchProbe (Enable External Latch) instruction was executed in Drive Mode for an encoder axis. 				√		page A-179
54015493 hex	Master Axis Offset Out of Range	The parameter specified for the <i>MasterOffset</i> input variable to a motion control instruction is out of range.	<ul style="list-style-type: none"> The instruction input parameter exceeded the range of signed 40-bit data when it is converted to pulses. 				√		page A-179
54015494 hex	Slave Axis Offset Out of Range	The parameter specified for the <i>SlaveOffset</i> input variable to a motion control instruction is out of range.	<ul style="list-style-type: none"> The instruction input parameter exceeded the range of signed 40-bit data when it is converted to pulses. 				√		page A-180
54015495 hex	Command Current Position Count Selection Out of Range	The parameter specified for the <i>CmdPosMode</i> input variable to a motion control instruction is out of range.	<ul style="list-style-type: none"> Instruction input parameter exceeded the valid range of the input variable. 				√		page A-180
54015496 hex	Master Axis Gear Ratio Numerator Out of Range	The parameter specified for the <i>RatioNumerator-Master</i> input variable to a motion control instruction is out of range.	<ul style="list-style-type: none"> Instruction input parameter exceeded the valid range of the input variable. 				√		page A-181
54015497 hex	Master Axis Gear Ratio Denominator Out of Range	The parameter specified for the <i>RatioDenominator-Master</i> input variable to a motion control instruction is out of range.	<ul style="list-style-type: none"> Instruction input parameter exceeded the valid range of the input variable. 				√		page A-181
54015498 hex	Auxiliary Axis Gear Ratio Numerator Out of Range	The parameter specified for the <i>RatioNumeratorAuxiliary</i> input variable to a motion control instruction is out of range.	<ul style="list-style-type: none"> Instruction input parameter exceeded the valid range of the input variable. 				√		page A-182
54015499 hex	Auxiliary Axis Gear Ratio Denominator Out of Range	The parameter specified for the <i>RatioDenominatorAuxiliary</i> input variable to a motion control instruction is out of range.	<ul style="list-style-type: none"> Instruction input parameter exceeded the valid range of the input variable. 				√		page A-182
5401549A hex	Master Axis Position Type Selection Out of Range	The parameter specified for the <i>ReferenceType-Master</i> input variable to a motion control instruction is out of range.	<ul style="list-style-type: none"> Instruction input parameter exceeded the valid range of the input variable. 				√		page A-183
5401549B hex	Auxiliary Axis Position Type Selection Out of Range	The parameter specified for the <i>Reference-TypeAuxiliary</i> input variable to a motion control instruction is out of range.	<ul style="list-style-type: none"> Instruction input parameter exceeded the valid range of the input variable. 				√		page A-183
5401549C hex	Target Position Ring Counter Out of Range	Operation is not possible because the target position is out of range for the ring counter of the executed instruction.	<ul style="list-style-type: none"> High-speed homing was executed when 0 was not included in the ring counter. 				√		page A-184

Event code	Event name	Meaning	Assumed cause	Level					Reference
				Maj	Prt	Min	Obs	Info	
5401549D hex (Ver. 1.01 or later)	Axes Group Composition Axis Setting Out of Range	The parameter specified for the <i>Axes</i> input variable to a motion control instruction is out of range.	<ul style="list-style-type: none"> Instruction input parameter exceeded the valid range of the input variable. The composition axes in the axes group are not assigned to the same task. 				√		page A-184
5401549E hex (Ver. 1.04 or later)	Axis Use Setting Out of Range	The parameter specified for the <i>AxisUse</i> input variable to a motion control instruction is out of range.	<ul style="list-style-type: none"> Instruction input parameter exceeded the valid range of the input variable. 				√		page A-185
54015700 hex (Ver. 1.03 or later)	Homing Parameter Setting Out of Range	The parameter specified for the <i>HomingParameter</i> input variable to a motion control instruction is out of range.	<ul style="list-style-type: none"> Instruction input parameter exceeded the valid range of the input variable. 				√		page A-185
54015702 hex (Ver. 1.04 or later)	Axis Use Change Error	The MC_ChangeAxisUse (Change Axis Use) instruction was executed when the axis was not stopped or when the command velocity of the axis was saturated.	<ul style="list-style-type: none"> The MC_ChangeAxisUse (Change Axis Use) instruction was executed when the axis was not stopped or when the command velocity of the axis was saturated. 				√		page A-186
54015703 hex (Ver. 1.06 or later)	Cannot Change Axis Use	The MC_ChangeAxisUse (Change Axis Use) instruction was executed in a way that would cause the maximum number of used real axes or the maximum number of used motion control servo axes to be exceeded.	<ul style="list-style-type: none"> The MC_ChangeAxisUse (Change Axis Use) instruction was executed in a way that would cause the maximum number of used real axes to be exceeded. The MC_ChangeAxisUse (Change Axis Use) instruction was executed in a way that would cause the maximum number of used motion control servo axes to be exceeded. 				√		page A-187
54015720 hex (Ver. 1.04 or later)	Motion Control Parameter Setting Error When Changing Axis Use	The motion control parameter settings for the axis that was changed to a used axis are incorrect.	<ul style="list-style-type: none"> The MC_ChangeAxisUse (Change Axis Use) instruction was used to change an unused axis to a used axis, but the motion control parameter settings of the axis are not correct. The power supply was interrupted while a download of the motion control parameter settings was in progress. The non-volatile memory is faulty or the life of the non-volatile memory has been exceeded. 				√		page A-188

Event code	Event name	Meaning	Assumed cause	Level					Reference
				Maj	Prt	Min	Obs	Info	
54015721 hex (Ver. 1.04 or later)	Required Process Data Object Not Set When Changing Axis Use	The objects that are required for the axis type of the axis that was changed to a used axis are not set.	<ul style="list-style-type: none"> The objects that are required for the axis type of the axis that was changed to a used axis are not set in the PDO map settings. The power supply was interrupted while a download of the motion control parameter settings was in progress. The non-volatile memory is faulty or the life of the non-volatile memory has been exceeded. The MC_ChangeAxisUse (Change Axis Use) instruction was executed for an axis that is set to <i>Unused axis (unchangeable to used axis)</i>. 				√		page A-189
54015722 hex (Ver. 1.06 or later)	Actual Position Overflow/Underflow	An instruction was executed that is not supported during an actual position overflow/underflow.	<ul style="list-style-type: none"> An instruction was executed that is not supported during an actual position overflow or underflow. 				√		page A-190
54015723 hex (Ver. 1.06 or later)	Switch Structure Track Number Setting Out of Range	The value of <i>TrackNumber</i> that is specified in the <i>Switches</i> in-out variable to a motion control instruction is out of range.	<ul style="list-style-type: none"> The value of the member of the structure variable that was specified for the in-out variable of the instruction is out of range. 				√		page A-190
54015724 hex (Ver. 1.06 or later)	Switch Structure First ON Position Setting Out of Range	The value of <i>FirstOnPosition</i> that is specified in the <i>Switches</i> in-out variable to a motion control instruction is out of range.	<ul style="list-style-type: none"> The value of the member of the structure variable that was specified for the in-out variable of the instruction is out of range. 				√		page A-191
54015725 hex (Ver. 1.06 or later)	Switch Structure Last ON Position Setting Out of Range	The value of <i>LastOnPosition</i> that is specified in the <i>Switches</i> in-out variable to a motion control instruction is out of range.	<ul style="list-style-type: none"> The value of the member of the structure variable that was specified for the in-out variable of the instruction is out of range. 				√		page A-191
54015726 hex (Ver. 1.06 or later)	Switch Structure Axis Direction Out of Range	The value of <i>AxisDirection</i> that is specified in the <i>Switches</i> in-out variable to a motion control instruction is out of range.	<ul style="list-style-type: none"> The value of the member of the structure variable that was specified for the in-out variable of the instruction is out of range. 				√		page A-192
54015727 hex (Ver. 1.06 or later)	Switch Structure Cam Switch Mode Out of Range	The value of <i>CamSwitchMode</i> that is specified in the <i>Switches</i> in-out variable to a motion control instruction is out of range.	<ul style="list-style-type: none"> The value of the member of the structure variable that was specified for the in-out variable of the instruction is out of range. 				√		page A-192
54015728 hex (Ver. 1.06 or later)	Switch Structure Duration Setting Out of Range	The value of <i>Duration</i> that is specified in the <i>Switches</i> in-out variable to a motion control instruction is out of range.	<ul style="list-style-type: none"> The value of the member of the structure variable that was specified for the in-out variable of the instruction is out of range. 				√		page A-193
54015729 hex (Ver. 1.06 or later)	Track Option Structure ON Compensation Setting Out of Range	The value of <i>OnCompensation</i> that is specified in the <i>TrackOptions</i> in-out variable to a motion control instruction is out of range.	<ul style="list-style-type: none"> The value of the member of the structure variable that was specified for the in-out variable of the instruction is out of range. 				√		page A-193

Event code	Event name	Meaning	Assumed cause	Level					Reference
				Maj	Prt	Min	Obs	Info	
5401572A hex (Ver. 1.06 or later)	Track Option Structure OFF Compensation Setting Out of Range	The value of <i>OffCompensation</i> that is specified in the <i>TrackOptions</i> in-out variable to a motion control instruction is out of range.	<ul style="list-style-type: none"> The value of the member of the structure variable that was specified for the in-out variable of the instruction is out of range. 				√		page A-194
5401572B hex (Ver. 1.06 or later)	Number of Array Elements in Switch Structure Variable Out of Range	The number of elements in an array in the structure variable that is specified in the <i>Switches</i> in-out variable to a motion control instruction is out of range.	<ul style="list-style-type: none"> The number of elements in an array of the structure variable that was specified for the in-out variable of the instruction is out of range. 				√		page A-194
5401572C hex (Ver. 1.06 or later)	Number of Array Elements in Output Signal Structure Variable Out of Range	The number of elements in an array in the structure variable that is specified in the <i>Outputs</i> in-out variable to a motion control instruction is out of range.	<ul style="list-style-type: none"> The number of elements in an array of the structure variable that was specified for the in-out variable of the instruction is out of range. 				√		page A-195
5401572D hex (Ver. 1.06 or later)	Number of Array Elements in Track Option Structure Variable Out of Range	The number of elements in an array in the structure variable that is specified in the <i>TrackOptions</i> in-out variable to a motion control instruction is out of range.	<ul style="list-style-type: none"> The number of elements in an array of the structure variable that was specified for the in-out variable of the instruction is out of range. 				√		page A-195
5401572E hex (Ver. 1.06 or later)	Numbers of Elements in Output Signals and Track Option Arrays Not Matched	The arrays in the structure variables that are specified for the <i>Outputs</i> and <i>TrackOptions</i> in-out variables to a motion control instruction do not have the same number of elements.	<ul style="list-style-type: none"> The arrays in the output signal structure variable and track option structure variable that are specified for the in-out variables to the instruction do not have the same number of elements. 				√		page A-196
5401572F hex (Ver. 1.06 or later)	Motion Control Instruction Multi-execution Disabled (Master Axis)	A <i>Master</i> in-out variable that cannot be changed during multi-execution of instructions was changed	<ul style="list-style-type: none"> A <i>Master</i> in-out variable that cannot be changed during multi-execution of instructions was changed. 				√		page A-197
54015730 hex (Ver. 1.06 or later)	Motion Control Instruction Multi-execution Disabled (Position Type Selection)	A <i>ReferenceType</i> in-out variable that cannot be changed during multi-execution of instructions was changed	<ul style="list-style-type: none"> A <i>ReferenceType</i> in-out variable that cannot be changed during multi-execution of instructions was changed. 				√		page A-197
54015731 hex (Ver. 1.06 or later)	Same Track Number Setting in Switch Structure Out of Range	The same track number was specified more than the allowable number of times for the <i>TrackNumber</i> in the <i>Switches</i> in-out variable to a motion control instruction.	<ul style="list-style-type: none"> The same track number was specified more than the allowable number of times for the <i>TrackNumber</i> in the <i>Switches</i> in-out variable to a motion control instruction. 				√		page A-198
5401573A hex (Ver. 1.08 or later)	Cannot Write Axis Parameters	The instruction was executed for an axis that is not an unused axis.	<ul style="list-style-type: none"> The instruction was executed for a used axis or an undefined axis. 				√		page A-198
5401573B hex (Ver. 1.08 or later)	Axis Parameter Setting Out of Range	The parameter specified for the <i>AxisParameter</i> input variable to a motion control instruction is outside of the valid range.	<ul style="list-style-type: none"> The parameter specified for the <i>AxisParameter</i> input variable to the instruction is out of range for the input variable. 				√		page A-199
5401573C hex (Ver. 1.08 or later)	Cam Property Setting Out of Range	The parameter specified for the <i>CamProperty</i> input variable to a motion control instruction is outside of the valid range.	<ul style="list-style-type: none"> The parameter specified for the <i>CamProperty</i> input variable to the instruction is out of range for the input variable. 				√		page A-199

Event code	Event name	Meaning	Assumed cause	Level					Reference
				Maj	Prt	Min	Obs	Info	
5401573D hex (Ver. 1.08 or later)	Cam Node Setting Out of Range	The parameter specified for the <i>CamNodes</i> input variable to a motion control instruction is outside of the valid range.	<ul style="list-style-type: none"> The parameter specified for the <i>CamNodes</i> input variable to the instruction is out of range for the input variable. 				√		page A-200
5401573E hex (Ver. 1.08 or later)	Incorrect Cam Node Type Specification	The parameter specified for the <i>CamNodes</i> input variable to a motion control instruction is not an <i>_sMC_CAM_NODE</i> array variable.	<ul style="list-style-type: none"> The parameter specified for the <i>CamNodes</i> input variable to the instruction is not an <i>_sMC_CAM_NODE</i> array variable. 				√		page A-200
5401573F hex (Ver. 1.08 or later)	Insufficient Nodes in Cam Table	The array variable of the parameter specified for the <i>CamNodes</i> input variable to a motion control instruction has a <i>Phase</i> value of 0 for element number 0.	<ul style="list-style-type: none"> The array variable of the parameter specified for the <i>CamNodes</i> input variable to the instruction has a <i>Phase</i> (master axis phase) value of 0 for element number 0. 				√		page A-201
54015740 hex (Ver. 1.08 or later)	Cam Node Master Axis Phase Not in Ascending Order	The values of <i>Phase</i> in the array variable of the parameter specified for the <i>CamNodes</i> input variable to a motion control instruction are not in ascending order according to the element numbers.	<ul style="list-style-type: none"> The values of <i>Phase</i> (master axis phase) in the array variable of the parameter specified for the <i>CamNodes</i> input variable to the instruction are not in ascending order according to the element numbers. Or, truncating the digits that are not effective more than seven digits caused the phases to not be in ascending order. 				√		page A-201
54015741 hex (Ver. 1.08 or later)	Too Many Data Points in Cam Table	The number of generated cam data points exceeded the number of elements in the array in the cam data variable that is specified for the <i>CamTable</i> input variable to a motion control instruction.	<ul style="list-style-type: none"> The number of cam data points in the generated cam table exceeded the number of elements in the array in the cam data variable that is specified for the <i>CamTable</i> input variable to the instruction. 				√		page A-202
54015742 hex (Ver. 1.08 or later)	Cam Table Displacement Overflow	<i>Distance</i> in the generated cam table exceeded the range of REAL data.	<ul style="list-style-type: none"> <i>Distance</i> in the generated cam table exceeded the range of REAL data. 				√		page A-203
54015743 hex (Ver. 1.08 or later)	Aborted Cam Table Used	A cam data variable that was aborted during generation was specified for the <i>CamTable</i> input variable to an instruction.	<ul style="list-style-type: none"> A cam data variable that was aborted during generation due to an error in the <i>MC_GenerateCamTable</i> (Generate Cam Table) instruction was specified for the <i>CamTable</i> input variable to the instruction. 				√		page A-204
54015749 hex (Ver. 1.10 or later)	Execution ID Setting Out of Range	The parameter specified for the <i>ExecID</i> input variable to a motion control instruction is out of range.	<ul style="list-style-type: none"> The parameter specified for the <i>ExecID</i> input variable to the instruction is out of range for the input variable. 				√		page A-205
5401574A hex (Ver. 1.10 or later)	Position Offset Out of Range	The parameter specified for the <i>OffsetPosition</i> input variable to a motion control instruction is out of range.	<ul style="list-style-type: none"> The position offset exceeded the range of signed 40-bit data when it was converted to pulses. 				√		page A-205

Event code	Event name	Meaning	Assumed cause	Level					Reference
				Maj	Prt	Min	Obs	Info	
5401574B hex (Ver. 1.10 or later)	PDS State Transition Command Selection Out of Range	The parameter specified for the <i>TransitionCmd</i> input variable to a motion control instruction is out of range.	<ul style="list-style-type: none"> Instruction input parameter exceeded the valid range of the input variable. 				√		page A-206
5401574C hex (Ver. 1.13 or later)	Single-axis Position Control Axis Motion Control Instruction Execution Disabled	An operation instruction was executed for a single-axis position control axis.	<ul style="list-style-type: none"> An operation instruction was executed for a single-axis position control axis. 				√		page A-206
54016440 hex	Target Position Positive Software Limit Exceeded	The specified position exceeds the positive software limit.	<ul style="list-style-type: none"> The parameter specified for the <i>Position</i> input variable to the instruction is beyond the positive software limit. The first position is beyond the positive software limit and an instruction that specifies motion in the opposite direction of the software limit was executed. The parameter that was specified for the <i>AuxPoint</i> input variable to a border point MC_MoveCircular2D (Circular 2D Interpolation) instruction is beyond the positive software limit. 				√		page A-207
54016441 hex	Target Position Negative Software Limit Exceeded	The specified position exceeds the negative software limit.	<ul style="list-style-type: none"> The parameter specified for the <i>Position</i> input variable to the instruction is beyond the negative software limit. The first position is beyond the negative software limit and an instruction that specifies motion in the opposite direction of the software limit was executed. The parameter that was specified for the <i>AuxPoint</i> input variable to a border point MC_MoveCircular2D (Circular 2D Interpolation) instruction is beyond the negative software limit. 				√		page A-208
54016442 hex	Command Position Overflow/Underflow	Positioning, an instruction in the underflow/overflow direction, or an instruction for which the direction is not specified was executed when there was an underflow/overflow in the command position.	<ul style="list-style-type: none"> One of the following was executed when there was a command position overflow/underflow. <ul style="list-style-type: none"> A positioning instruction A continuous control instruction in the underflow/overflow direction An instruction for which the direction is not specified (syncing or torque control) 				√		page A-209

Event code	Event name	Meaning	Assumed cause	Level					Reference
				Maj	Prt	Min	Obs	Info	
54016443 hex	Positive Limit Input	An instruction was executed for a motion in the positive direction when the positive limit input was ON.	<ul style="list-style-type: none"> An instruction for a motion in the positive direction was executed when the positive limit input was ON, or an instruction for a motion with no direction specification was executed when the positive limit input was ON. An axes group motion control instruction was executed when the positive limit input was ON. 				√		page A-210
54016444 hex	Negative Limit Input	An instruction for a motion in the negative direction was executed when the negative limit input was ON.	<ul style="list-style-type: none"> An instruction for a motion in the negative direction was executed when the negative limit input was ON, or an instruction for a motion with no direction specification was executed when the negative limit input was ON. An axes group motion control instruction was executed when the negative limit input was ON. 				√		page A-211
54017422 hex	Servo Main Circuits OFF	An attempt was made to turn ON the Servo when the main circuit power supply to the Servo Drive was OFF.	<ul style="list-style-type: none"> An attempt was made to turn ON the Servo when the main circuit power supply to the Servo Drive was OFF. 				√		page A-211

A-3 Error Code Details

This appendix provides detailed information on errors (events) that occur for instructions. The lower four digits of the event code give the error code for the instruction. For descriptions of the error codes, refer to the descriptions of the corresponding event codes. For example, if the error code of the instruction is 16#0400, refer to the description of the event with event code 54010400 hex.

Error Descriptions

The items that are used to describe individual errors (events) are described in the following copy of an error table.

Event name	Gives the name of the error.			Event code	Gives the code of the error.	
Meaning	Gives a short description of the error.					
Source	Gives the source of the error.		Source details	Gives details on the source of the error.	Detection timing	Tells when the error is detected.
Error attributes	Level	Tells the level of influence on control.*1	Recovery	Gives the recovery method.*2	Log category	Tells which log the error is saved in.*3
Effects	User program	Tells what will happen to execution of the user program.*4	Operation	Provides special information on the operation that results from the error.		
Indicators	Gives the status of the built-in EtherNet/IP port and built-in EtherCAT port indicators. Indicator status is given only for errors in the EtherCAT Master Function Module and the EtherNet/IP Function Module.					
System-defined variables	Variable	Data type		Name		
	Lists the variable names, data types, and meanings for system-defined variables that provide direct error notification, that are directly affected by the error, or that contain settings that cause the error.					
Cause and correction	Assumed cause		Correction		Prevention	
	Lists the possible causes, corrections, and preventive measures for the error.					
Attached information	This is the attached information that is displayed by the Sysmac Studio or an HMI.*5					
Precautions/Remarks	Provides precautions, restrictions, and supplemental information.					

- *1 One of the following:
 Major fault: Major fault level
 Partial fault: Partial fault level
 Minor fault: Minor fault level
 Observation Information
- *2 One of the following:
 Automatic recovery: Normal status is restored automatically when the cause of the error is removed.
 Error reset: Normal status is restored when the error is reset after the cause of the error is removed.
 Cycle the power supply: Normal status is restored when the power supply to the Controller is turned OFF and then back ON after the cause of the error is removed.
 Controller reset: Normal status is restored when the Controller is reset after the cause of the error is removed.
 Depends on cause: The recovery method depends on the cause of the error.
- *3 One of the following:
 System: System event log
 Access: Access event log
- *4 One of the following:
 Continues: Execution of the user program will continue.
 Stops: Execution of the user program stops.
 Starts: Execution of the user program starts.
- *5 Refer to the appendices of the *NJ/NX-series Troubleshooting Manual* (Cat. No. W503) for the applicable range of the HMI Troubleshooter.

Instructions

Event name	Input Value Out of Range		Event code	54010400 hex		
Meaning	An input parameter for an instruction exceeded the valid range for an input variable. Or, division by an integer of 0 occurred in division or remainder calculations.					
Source	PLC Function Module		Source details	Instruction	Detection timing	At instruction execution
Error attributes	Level	Observation	Recovery	---	Log category	System
Effects	User program	Continues.	Operation	The relevant instruction will end according to specifications.		
System-defined variables	Variable		Data type		Name	
	None		---		---	
Cause and correction	Assumed cause		Correction		Prevention	
	An input parameter for an instruction exceeded the valid range for an input variable. Or, division by an integer of 0 occurred in division or remainder calculations.		Check the valid range for the input variables of the instruction. Make sure the input parameters are within the valid range and that no division by 0 or remainder calculation for 0 is performed.		Set the value of the input parameter to the instruction so that the input range is not exceeded.	
Attached information	<p>Attached Information 1: Error Location</p> <p>Attached Information 2: Error Location Details (Rung Number). For a program section, the rung number from the start of the section is given. For ST, the line number is given.</p> <p>Attached Information 3: Names of the Instruction and Instruction Instance Where the Error Occurred. If there is more than one possible instruction, information is given on all of them. Nothing is given if the instruction cannot be identified.</p> <p>Attached Information 4: Expansion Error Code (<i>ErrorIDEx</i>)</p>					
Precautions/Remarks	If a program is changed after an error occurs, the attached information that is displayed may not be correct.					

Event name	Input Mismatch		Event code	54010401 hex		
Meaning	The relationship for the instruction input parameters did not meet required conditions. Or, a numeric value during or after instruction execution did not meet conditions.					
Source	PLC Function Module		Source details	Instruction	Detection timing	At instruction execution
Error attributes	Level	Observation	Recovery	---	Log category	System
Effects	User program	Continues.	Operation	The relevant instruction will end according to specifications.		
System-defined variables	Variable		Data type		Name	
	None		---		---	
Cause and correction	Assumed cause		Correction		Prevention	
	The relationship for an input parameter did not meet required conditions.		Check the meaning and the relationship of the input variables of the instruction. Correct them so that the relationships for the input parameters meet the required conditions.		Set the input parameter to the instruction so that the value meets the conditions of the relationship for the input variables.	
	A value when processing an instruction or in the result does not meet the conditions.		Check the execution process of the instruction. Set the value of the input parameter so that it does not cause inappropriate processing results.		Check the execution process of the instruction. Set the input parameter so that it does not cause this error during processing.	
Attached information	<p>Attached Information 1: Error Location</p> <p>Attached Information 2: Error Location Details (Rung Number). For a program section, the rung number from the start of the section is given. For ST, the line number is given.</p> <p>Attached Information 3: Names of the Instruction and Instruction Instance Where the Error Occurred. If there is more than one possible instruction, information is given on all of them. Nothing is given if the instruction cannot be identified.</p> <p>Attached Information 4: Expansion Error Code (<i>ErrorIDEx</i>)</p>					
Precautions/Remarks	If a program is changed after an error occurs, the attached information that is displayed may not be correct.					

Event name	Floating-point Error			Event code	54010402 hex	
Meaning	Non-numeric data was input for a floating-point number input parameter to an instruction.					
Source	PLC Function Module		Source details	Instruction	Detection timing	At instruction execution
Error attributes	Level	Observation	Recovery	---	Log category	System
Effects	User program	Continues.	Operation	The relevant instruction will end according to specifications.		
System-defined variables	Variable		Data type		Name	
	None		---		---	
Cause and correction	Assumed cause		Correction		Prevention	
	Non-numeric data was input for a floating-point number input parameter to an instruction.		Correct the instruction so that a numeric value is input for the floating-point number input parameter.		Use numeric values for the floating-point number input parameters.	
Attached information	<p>Attached Information 1: Error Location</p> <p>Attached Information 2: Error Location Details (Rung Number). For a program section, the rung number from the start of the section is given. For ST, the line number is given.</p> <p>Attached Information 3: Names of the Instruction and Instruction Instance Where the Error Occurred. If there is more than one possible instruction, information is given on all of them. Nothing is given if the instruction cannot be identified.</p> <p>Attached Information 4: Expansion Error Code (<i>ErrorIDEx</i>)</p>					
Precautions/Remarks	If a program is changed after an error occurs, the attached information that is displayed may not be correct.					

Event name	BCD Error			Event code	54010403 hex	
Meaning	A value that was not BCD was input for a BCD input parameter to an instruction.					
Source	PLC Function Module		Source details	Instruction	Detection timing	At instruction execution
Error attributes	Level	Observation	Recovery	---	Log category	System
Effects	User program	Continues.	Operation	The relevant instruction will end according to specifications.		
System-defined variables	Variable		Data type		Name	
	None		---		---	
Cause and correction	Assumed cause		Correction		Prevention	
	A hexadecimal digit of A, B, C, D, E, or F was input for a BCD input parameter to an instruction.		Correct the instruction so that BCD data is input for the BCD input parameter.		Change the BCD input parameter for the instruction to BCD data.	
Attached information	<p>Attached Information 1: Error Location</p> <p>Attached Information 2: Error Location Details (Rung Number). For a program section, the rung number from the start of the section is given. For ST, the line number is given.</p> <p>Attached Information 3: Names of the Instruction and Instruction Instance Where the Error Occurred. If there is more than one possible instruction, information is given on all of them. Nothing is given if the instruction cannot be identified.</p> <p>Attached Information 4: Expansion Error Code (<i>ErrorIDEx</i>)</p>					
Precautions/Remarks	If a program is changed after an error occurs, the attached information that is displayed may not be correct.					

Event name	Signed BCD Error		Event code	54010404 hex		
Meaning	An illegal value was input for the most significant digit for a signed BCD input parameter to an instruction.					
Source	PLC Function Module		Source details	Instruction	Detection timing	At instruction execution
Error attributes	Level	Observation	Recovery	---	Log category	System
Effects	User program	Continues.	Operation	The relevant instruction will end according to specifications.		
System-defined variables	Variable		Data type		Name	
	None		---		---	
Cause and correction	Assumed cause		Correction		Prevention	
	<p>An illegal value was input for the most significant digit for a signed BCD input parameter to an instruction.</p> <ul style="list-style-type: none"> The most-significant digit was 2 to F when <code>_BCD0</code> was specified as the BCD format. The most-significant digit was A, B, C, D, or E when <code>_BCD2</code> was specified as the BCD format. The most-significant digit was B, C, D, or E when <code>_BCD3</code> was specified as the BCD format. 		<p>Correct the instruction so that proper signed BCD data is input for the BCD input parameter.</p>		<p>Set the most-significant digit of the signed BCD data input parameter for the instruction to the correct value.</p>	
Attached information	<p>Attached Information 1: Error Location</p> <p>Attached Information 2: Error Location Details (Rung Number). For a program section, the rung number from the start of the section is given. For ST, the line number is given.</p> <p>Attached Information 3: Names of the Instruction and Instruction Instance Where the Error Occurred. If there is more than one possible instruction, information is given on all of them. Nothing is given if the instruction cannot be identified.</p> <p>Attached Information 4: Expansion Error Code (<i>ErrorIDEx</i>)</p>					
Precautions/Remarks	If a program is changed after an error occurs, the attached information that is displayed may not be correct.					

Event name	Illegal Bit Position Specified		Event code	54010405 hex		
Meaning	The bit position specified for an instruction was illegal.					
Source	PLC Function Module		Source details	Instruction	Detection timing	At instruction execution
Error attributes	Level	Observation	Recovery	---	Log category	System
Effects	User program	Continues.	Operation	The relevant instruction will end according to specifications.		
System-defined variables	Variable		Data type		Name	
	None		---		---	
Cause and correction	Assumed cause		Correction		Prevention	
	<p>The bit position specified for an instruction exceeds the data range.</p>		<p>Correct the instruction so that the bit position specified for an instruction does not exceed the data range.</p>		<p>Use the instruction so that the bit position specified for an instruction does not exceed the data range.</p>	
Attached information	<p>Attached Information 1: Error Location</p> <p>Attached Information 2: Error Location Details (Rung Number). For a program section, the rung number from the start of the section is given. For ST, the line number is given.</p> <p>Attached Information 3: Names of the Instruction and Instruction Instance Where the Error Occurred. If there is more than one possible instruction, information is given on all of them. Nothing is given if the instruction cannot be identified.</p> <p>Attached Information 4: Expansion Error Code (<i>ErrorIDEx</i>)</p>					
Precautions/Remarks	If a program is changed after an error occurs, the attached information that is displayed may not be correct.					

Event name	Illegal Data Position Specified			Event code	54010406 hex	
Meaning	A memory address or data size that was specified for the instruction is not suitable.					
Source	PLC Function Module		Source details	Instruction	Detection timing	At instruction execution
Error attributes	Level	Observation	Recovery	---	Log category	System
Effects	User program	Continues.	Operation	The relevant instruction will end according to specifications.		
System-defined variables	Variable		Data type		Name	
	None		---		---	
Cause and correction	Assumed cause		Correction		Prevention	
	A memory address that was specified for an instruction was outside the valid range. The data size that was specified for an instruction exceeded the valid range. For example, the data type of a variable and the data size may not agree.		Correct the instruction so that the data position or data size specified for an instruction does not exceed the range of the data area.		Use the instruction so that the data position or data size specified for an instruction does not exceed the data range.	
Attached information	<p>Attached Information 1: Error Location</p> <p>Attached Information 2: Error Location Details (Rung Number). For a program section, the rung number from the start of the section is given. For ST, the line number is given.</p> <p>Attached Information 3: Names of the Instruction and Instruction Instance Where the Error Occurred. If there is more than one possible instruction, information is given on all of them. Nothing is given if the instruction cannot be identified.</p> <p>Attached Information 4: Expansion Error Code (<i>ErrorIDEx</i>)</p>					
Precautions/Remarks	If a program is changed after an error occurs, the attached information that is displayed may not be correct.					

Event name	Data Range Exceeded			Event code	54010407 hex	
Meaning	The results of instruction processing exceeded the data area range of the output parameter.					
Source	PLC Function Module		Source details	Instruction	Detection timing	At instruction execution
Error attributes	Level	Observation	Recovery	---	Log category	System
Effects	User program	Continues.	Operation	The relevant instruction will end according to specifications.		
System-defined variables	Variable		Data type		Name	
	None		---		---	
Cause and correction	Assumed cause		Correction		Prevention	
	The results of instruction processing, such as the number of array elements, exceeded the data area range of the output parameter.		Correct the input parameters so that the processing result of the instruction does not exceed the range of the data area of the output parameter.		Set the input parameter so that the processing result of the instruction does not exceed the range of the data area of the output parameter.	
Attached information	<p>Attached Information 1: Error Location</p> <p>Attached Information 2: Error Location Details (Rung Number). For a program section, the rung number from the start of the section is given. For ST, the line number is given.</p> <p>Attached Information 3: Names of the Instruction and Instruction Instance Where the Error Occurred. If there is more than one possible instruction, information is given on all of them. Nothing is given if the instruction cannot be identified.</p> <p>Attached Information 4: Expansion Error Code (<i>ErrorIDEx</i>)</p>					
Precautions/Remarks	If a program is changed after an error occurs, the attached information that is displayed may not be correct.					

Event name	No Errors to Clear		Event code	54010409 hex		
Meaning	An instruction to clear a Controller error was executed when there was no error in the Controller.					
Source	PLC Function Module		Source details	Instruction	Detection timing	At instruction execution
Error attributes	Level	Observation	Recovery	---	Log category	System
Effects	User program	Continues.	Operation	The relevant instruction will end according to specifications. The output or Unit operation is not affected.		
System-defined variables	Variable		Data type		Name	
	None		---		---	
Cause and correction	Assumed cause		Correction		Prevention	
	An instruction to clear a Controller error was executed when there was no error in the Controller.		Correct the program so that the instruction is executed when there is a Controller error.		Write the program so that the instruction is executed when there is a Controller error.	
Attached information	<p>Attached Information 1: Error Location</p> <p>Attached Information 2: Error Location Details (Rung Number). For a program section, the rung number from the start of the section is given. For ST, the line number is given.</p> <p>Attached Information 3: Names of the Instruction and Instruction Instance Where the Error Occurred. If there is more than one possible instruction, information is given on all of them. Nothing is given if the instruction cannot be identified.</p> <p>Attached Information 4: Expansion Error Code (<i>ErrorIDEx</i>)</p>					
Precautions/Remarks	If a program is changed after an error occurs, the attached information that is displayed may not be correct.					

Event name	No User Errors to Clear		Event code	5401040B hex		
Meaning	An instruction to clear user-defined errors was executed when there was no user-defined error.					
Source	PLC Function Module		Source details	Instruction	Detection timing	At instruction execution
Error attributes	Level	Observation	Recovery	---	Log category	System
Effects	User program	Continues.	Operation	The relevant instruction will end according to specifications. The output or Unit operation is not affected.		
System-defined variables	Variable		Data type		Name	
	None		---		---	
Cause and correction	Assumed cause		Correction		Prevention	
	An instruction to clear user-defined errors was executed when there was no user-defined error.		Correct the program so that the instruction is executed when there is a user-defined error.		Write the program so that the instruction is executed when there is a user-defined error.	
Attached information	<p>Attached Information 1: Error Location</p> <p>Attached Information 2: Error Location Details (Rung Number). For a program section, the rung number from the start of the section is given. For ST, the line number is given.</p> <p>Attached Information 3: Names of the Instruction and Instruction Instance Where the Error Occurred. If there is more than one possible instruction, information is given on all of them. Nothing is given if the instruction cannot be identified.</p> <p>Attached Information 4: Expansion Error Code (<i>ErrorIDEx</i>)</p>					
Precautions/Remarks	If a program is changed after an error occurs, the attached information that is displayed may not be correct.					

Event name	Limit Exceeded for User-defined Errors			Event code	5401040C hex	
Meaning	An attempt was made to use the Create User-defined Error instruction to create more than the maximum number of user-defined errors.					
Source	PLC Function Module		Source details	Instruction	Detection timing	At instruction execution
Error attributes	Level	Observation	Recovery	---	Log category	System
Effects	User program	Continues.	Operation	The relevant instruction will end according to specifications. The output or Unit operation is not affected.		
System-defined variables	Variable		Data type		Name	
	None		---		---	
Cause and correction	Assumed cause		Correction		Prevention	
	An attempt was made to use the Create User-defined Error instruction to create more than the maximum number of user-defined errors.		Execute the Reset User-defined Error instruction. Monitor the number of user-defined errors in the system-defined variable to check the number of user-defined errors.		Write the program so that it checks the number of user-defined errors as a condition to execute the user-defined error instruction.	
Attached information	<p>Attached Information 1: Error Location</p> <p>Attached Information 2: Error Location Details (Rung Number). For a program section, the rung number from the start of the section is given. For ST, the line number is given.</p> <p>Attached Information 3: Names of the Instruction and Instruction Instance Where the Error Occurred. If there is more than one possible instruction, information is given on all of them. Nothing is given if the instruction cannot be identified.</p> <p>Attached Information 4: Expansion Error Code (<i>ErrorIDEx</i>)</p>					
Precautions/Remarks	If a program is changed after an error occurs, the attached information that is displayed may not be correct.					

Event name	Illegal Unit Specified			Event code	5401040D hex	
Meaning	The Unit specified for an instruction does not exist.					
Source	PLC Function Module		Source details	Instruction	Detection timing	At instruction execution
Error attributes	Level	Observation	Recovery	---	Log category	System
Effects	User program	Continues.	Operation	The relevant instruction will end according to specifications. The output or Unit operation is not affected.		
System-defined variables	Variable		Data type		Name	
	None		---		---	
Cause and correction	Assumed cause		Correction		Prevention	
	A Unit that does not exist in the Unit configuration information was specified.		Correct the unit number in the instruction so that it specifies a Unit in the Unit configuration and make sure that the actual Unit exists.		Make sure that unit numbers in instructions specify Units in the Unit configuration and make sure that the actual Units exist.	
Cause and correction	A Unit that is in the Unit configuration information was specified, but the Units does not actually exist in the Controller.					
Attached information	<p>Attached Information 1: Error Location</p> <p>Attached Information 2: Error Location Details (Rung Number). For a program section, the rung number from the start of the section is given. For ST, the line number is given.</p> <p>Attached Information 3: Names of the Instruction and Instruction Instance Where the Error Occurred. If there is more than one possible instruction, information is given on all of them. Nothing is given if the instruction cannot be identified.</p> <p>Attached Information 4: Expansion Error Code (<i>ErrorIDEx</i>)</p>					
Precautions/Remarks	If a program is changed after an error occurs, the attached information that is displayed may not be correct.					

Event name	Unit Restart Failed			Event code	5401040F hex	
Meaning	Restarting a Special I/O Unit or CPU Bus Unit failed.					
Source	PLC Function Module		Source details	Instruction	Detection timing	At instruction execution
Error attributes	Level	Observation	Recovery	---	Log category	System
Effects	User program	Continues.	Operation	The relevant instruction will end according to specifications. The output or Unit operation is not affected.		
System-defined variables	Variable		Data type		Name	
	None		---		---	
Cause and correction	Assumed cause		Correction		Prevention	
	The Special I/O Unit or CPU Bus Unit is processing data.		Wait a few moments and then restart the Special I/O Unit or CPU Bus Unit.		Check to be sure that Special I/O Units and CPU Bus Units are not processing data before restarting them from the user program.	
Attached information	<p>Attached Information 1: Error Location</p> <p>Attached Information 2: Error Location Details (Rung Number). For a program section, the rung number from the start of the section is given. For ST, the line number is given.</p> <p>Attached Information 3: Names of the Instruction and Instruction Instance Where the Error Occurred. If there is more than one possible instruction, information is given on all of them. Nothing is given if the instruction cannot be identified.</p> <p>Attached Information 4: Expansion Error Code (<i>ErrorIDEx</i>)</p>					
Precautions/Remarks	If a program is changed after an error occurs, the attached information that is displayed may not be correct.					

Event name	Text String Format Error			Event code	54010410 hex	
Meaning	The text string input to an instruction is not correct.					
Source	PLC Function Module		Source details	Instruction	Detection timing	At instruction execution
Error attributes	Level	Observation	Recovery	---	Log category	System
Effects	User program	Continues.	Operation	The relevant instruction will end according to specifications.		
System-defined variables	Variable		Data type		Name	
	None		---		---	
Cause and correction	Assumed cause		Correction		Prevention	
	The text string that is input to the instruction for conversion to a number does not represent a number or it does not represent a positive number.		Correct the text string so that it is properly formatted for the instruction.		When converting a text string to a number, make sure that the text string that is input to the instruction represents a number. If the number must be positive, make sure the text string represents a positive number.	
	The input text string does not end in NULL.		Correct the text string that is input to the instruction so that it ends in NULL.		When converting a text string to a number, make sure that the text string that is input to the instruction ends in NULL.	
Attached information	<p>Attached Information 1: Error Location</p> <p>Attached Information 2: Error Location Details (Rung Number). For a program section, the rung number from the start of the section is given. For ST, the line number is given.</p> <p>Attached Information 3: Names of the Instruction and Instruction Instance Where the Error Occurred. If there is more than one possible instruction, information is given on all of them. Nothing is given if the instruction cannot be identified.</p> <p>Attached Information 4: Expansion Error Code (<i>ErrorIDEx</i>)</p>					
Precautions/Remarks	If a program is changed after an error occurs, the attached information that is displayed may not be correct.					

Event name	Illegal Program Specified			Event code	54010411 hex	
Meaning	The program specified for an instruction does not exist.					
Source	PLC Function Module		Source details	Instruction	Detection timing	At instruction execution
Error attributes	Level	Observation	Recovery	---	Log category	System
Effects	User program	Continues.	Operation	The relevant instruction will end according to specifications.		
System-defined variables	Variable		Data type		Name	
	None		---		---	
Cause and correction	Assumed cause		Correction		Prevention	
	The program specified by the function does not exist (e.g., it was deleted).		Make sure that the program that is specified by the instruction exists. Or, add the program that is specified for the instruction.		Make sure that the programs that are specified by instructions exist. Be careful not to delete any programs that are used by instructions.	
Attached information	<p>Attached Information 1: Error Location</p> <p>Attached Information 2: Error Location Details (Rung Number). For a program section, the rung number from the start of the section is given. For ST, the line number is given.</p> <p>Attached Information 3: Names of the Instruction and Instruction Instance Where the Error Occurred. If there is more than one possible instruction, information is given on all of them. Nothing is given if the instruction cannot be identified.</p> <p>Attached Information 4: Expansion Error Code (<i>ErrorIDEx</i>)</p>					
Precautions/Remarks	If a program is changed after an error occurs, the attached information that is displayed may not be correct.					

Event name	Undefined CJ-series Memory Address			Event code	54010413 hex	
Meaning	The required specification is missing for a variable for which CJ-series Unit memory must be specified.					
Source	PLC Function Module		Source details	Instruction	Detection timing	At instruction execution
Error attributes	Level	Observation	Recovery	---	Log category	System
Effects	User program	Continues.	Operation	The relevant instruction will end according to specifications.		
System-defined variables	Variable		Data type		Name	
	None		---		---	
Cause and correction	Assumed cause		Correction		Prevention	
	The required AT specification is missing for a variable for which CJ-series Unit memory must be specified.		Correct the program so that it uses the AT specification to specify CJ-series Unit memory when doing so is required by the variable.		Write the program so that it uses an AT designation to specify CJ-series Unit memory when doing so is required by the variable.	
Attached information	<p>Attached Information 1: Error Location</p> <p>Attached Information 2: Error Location Details (Rung Number). For a program section, the rung number from the start of the section is given. For ST, the line number is given.</p> <p>Attached Information 3: Names of the Instruction and Instruction Instance Where the Error Occurred. If there is more than one possible instruction, information is given on all of them. Nothing is given if the instruction cannot be identified.</p> <p>Attached Information 4: Expansion Error Code (<i>ErrorIDEx</i>)</p>					
Precautions/Remarks	If a program is changed after an error occurs, the attached information that is displayed may not be correct.					

Event name	Stack Underflow		Event code	54010414 hex		
Meaning	There is no data in a stack.					
Source	PLC Function Module		Source details	Instruction	Detection timing	At instruction execution
Error attributes	Level	Observation	Recovery	---	Log category	System
Effects	User program	Continues.	Operation	The relevant instruction will end according to specifications.		
System-defined variables	Variable		Data type		Name	
	None		---		---	
Cause and correction	Assumed cause		Correction		Prevention	
	An attempt was made to read data from a stack that contains no data.		Correct the program so that the data is read only after it is stored in the stack.		Correct the program so that the data is read only after it is stored in the stack.	
Attached information	<p>Attached Information 1: Error Location</p> <p>Attached Information 2: Error Location Details (Rung Number). For a program section, the rung number from the start of the section is given. For ST, the line number is given.</p> <p>Attached Information 3: Names of the Instruction and Instruction Instance Where the Error Occurred. If there is more than one possible instruction, information is given on all of them. Nothing is given if the instruction cannot be identified.</p> <p>Attached Information 4: Expansion Error Code (<i>ErrorIDEx</i>)</p>					
Precautions/Remarks	If a program is changed after an error occurs, the attached information that is displayed may not be correct.					

Event name	Illegal Number of Array Elements or Dimensions		Event code	54010416 hex		
Meaning	The valid range was exceeded for the number of array elements or dimensions in an array I/O parameter for an instruction.					
Source	PLC Function Module		Source details	Instruction	Detection timing	At instruction execution
Error attributes	Level	Observation	Recovery	---	Log category	System
Effects	User program	Continues.	Operation	The relevant instruction will end according to specifications.		
System-defined variables	Variable		Data type		Name	
	None		---		---	
Cause and correction	Assumed cause		Correction		Prevention	
	The valid range was exceeded for the number of array elements or dimensions in an array I/O parameter for an instruction.		Correct the instruction so that the valid range for the number of array elements or dimensions in an array I/O parameter is not exceeded.		Correct the instruction so that the valid range for the number of array elements or dimensions in an array I/O parameter is not exceeded.	
Attached information	<p>Attached Information 1: Error Location</p> <p>Attached Information 2: Error Location Details (Rung Number). For a program section, the rung number from the start of the section is given. For ST, the line number is given.</p> <p>Attached Information 3: Names of the Instruction and Instruction Instance Where the Error Occurred. If there is more than one possible instruction, information is given on all of them. Nothing is given if the instruction cannot be identified.</p> <p>Attached Information 4: Expansion Error Code (<i>ErrorIDEx</i>)</p>					
Precautions/Remarks	If a program is changed after an error occurs, the attached information that is displayed may not be correct.					

Event name	Specified Task Does Not Exist			Event code	54010417 hex	
Meaning	The task specified for the instruction does not exist.					
Source	PLC Function Module		Source details	Instruction	Detection timing	At instruction execution
Error attributes	Level	Observation	Recovery	---	Log category	System
Effects	User program	Continues.	Operation	The relevant instruction will end according to specifications.		
System-defined variables	Variable		Data type		Name	
	None		---		---	
Cause and correction	Assumed cause		Correction		Prevention	
	The specified task does not exist.		Correct the user program so that it specifies an existing task.		Write the user program so that it specifies only existing tasks.	
Attached information	<p>Attached Information 1: Error Location</p> <p>Attached Information 2: Error Location Details (Rung Number). For a program section, the rung number from the start of the section is given. For ST, the line number is given.</p> <p>Attached Information 3: Names of the Instruction and Instruction Instance Where the Error Occurred. If there is more than one possible instruction, information is given on all of them. Nothing is given if the instruction cannot be identified.</p> <p>Attached Information 4: Expansion Error Code (<i>ErrorIDEx</i>)</p>					
Precautions/Remarks	If a program is changed after an error occurs, the attached information that is displayed may not be correct.					

Event name	Unallowed Task Specification			Event code	54010418 hex	
Meaning	An unallowed task was specified for an instruction.					
Source	PLC Function Module		Source details	Instruction	Detection timing	At instruction execution
Error attributes	Level	Observation	Recovery	---	Log category	System
Effects	User program	Continues.	Operation	The relevant instruction will end according to specifications.		
System-defined variables	Variable		Data type		Name	
	None		---		---	
Cause and correction	Assumed cause		Correction		Prevention	
	The local task, the primary periodic task, or a periodic task was specified.		Correct the user program so that it specifies an event task that is not the local task.		Write the user program so that it specifies event tasks that are not the local task.	
Attached information	<p>Attached Information 1: Error Location</p> <p>Attached Information 2: Error Location Details (Rung Number). For a program section, the rung number from the start of the section is given. For ST, the line number is given.</p> <p>Attached Information 3: Names of the Instruction and Instruction Instance Where the Error Occurred. If there is more than one possible instruction, information is given on all of them. Nothing is given if the instruction cannot be identified.</p> <p>Attached Information 4: Expansion Error Code (<i>ErrorIDEx</i>)</p>					
Precautions/Remarks	If a program is changed after an error occurs, the attached information that is displayed may not be correct.					

Event name	Incorrect Data Type			Event code	54010419 hex	
Meaning	A data type that cannot be used for an instruction is specified for an input or in-out variable.					
Source	PLC Function Module		Source details	Instruction	Detection timing	At instruction execution
Error attributes	Level	Observation	Recovery	---	Log category	System
Effects	User program	Continues.	Operation	The relevant instruction will end according to specifications.		
System-defined variables	Variable		Data type		Name	
	None		---		---	
Cause and correction	Assumed cause		Correction		Prevention	
	A data type that cannot be used for an instruction is specified for an input or in-out variable.		Check the data types of the input and in-out variables of the instruction and correct them to correct data types.		Check the allowed data types for input and in-out variables for the instruction and use correct data types.	
Attached information	<p>Attached Information 1: Error Location</p> <p>Attached Information 2: Error Location Details (Rung Number). For a program section, the rung number from the start of the section is given. For ST, the line number is given.</p> <p>Attached Information 3: Names of the Instruction and Instruction Instance Where the Error Occurred. If there is more than one possible instruction, information is given on all of them. Nothing is given if the instruction cannot be identified.</p> <p>Attached Information 4: Expansion Error Code (<i>ErrorIDEx</i>)</p>					
Precautions/Remarks	If a program is changed after an error occurs, the attached information that is displayed may not be correct.					

Event name	Multi-execution of Instructions			Event code	5401041A hex	
Meaning	Multi-execution was specified for an instruction that does not support it.					
Source	PLC Function Module		Source details	Instruction	Detection timing	At instruction execution
Error attributes	Level	Observation	Recovery	---	Log category	System
Effects	User program	Continues.	Operation	The relevant instruction will end according to specifications.		
System-defined variables	Variable		Data type		Name	
	None		---		---	
Cause and correction	Assumed cause		Correction		Prevention	
	Execution of an instruction that does not support multi-execution of instructions was specified more than once.		Correct the program so that any instance of an instruction that does not support multi-execution is completed before another instance is executed.		Write the user program so that any instance of an instruction that does not support multi-execution is completed before another instance is executed.	
Attached information	<p>Attached Information 1: Error Location</p> <p>Attached Information 2: Error Location Details (Rung Number). For a program section, the rung number from the start of the section is given. For ST, the line number is given.</p> <p>Attached Information 3: Names of the Instruction and Instruction Instance Where the Error Occurred. If there is more than one possible instruction, information is given on all of them. Nothing is given if the instruction cannot be identified.</p> <p>Attached Information 4: Expansion Error Code (<i>ErrorIDEx</i>)</p>					
Precautions/Remarks	If a program is changed after an error occurs, the attached information that is displayed may not be correct.					

Event name	Data Capacity Exceeded			Event code	5401041B hex*	
Meaning	The data that was passed to the instruction was too large to process.					
Source	PLC Function Module		Source details	Instruction	Detection timing	At instruction execution
Error attributes	Level	Observation	Recovery	---	Log category	System
Source	PLC Function Module		Source details	Instruction	Detection timing	At instruction execution
Error attributes	Level	Observation	Recovery	---	Log category	System
Effects	User program	Continues.	Operation	The relevant instruction will end according to specifications.		
System-defined variables	Variable		Data type		Name	
	None		---		---	
Cause and correction	Assumed cause		Correction		Prevention	
	Data that was larger than the capacity that can be processed was passed to the instruction.		Correct the program so that the size of the data that is passed to the instruction does not exceed the processing capacity.		Make sure that the data that is passed to the instruction is not larger than the processing capacity.	
Attached information	<p>Attached Information 1: Error Location</p> <p>Attached Information 2: Error Location Details (Rung Number). For a program section, the rung number from the start of the section is given. For ST, the line number is given.</p> <p>Attached Information 3: Names of the Instruction and Instruction Instance Where the Error Occurred. If there is more than one possible instruction, information is given on all of them. Nothing is given if the instruction cannot be identified.</p> <p>Attached Information 4: Expansion Error Code (<i>ErrorIDEx</i>)</p>					
Precautions/Remarks	If a program is changed after an error occurs, the attached information that is displayed may not be correct.					

* Error code 16#041B occurs for unit version 1.02 or later of the CPU Unit.

Event name	Different Data Sizes			Event code	5401041C hex*	
Meaning	The size of the data specified for instruction input or in-out data is different from the size of the target parameter.					
Source	PLC Function Module		Source details	Instruction	Detection timing	At instruction execution
Error attributes	Level	Observation	Recovery	---	Log category	System
Effects	User program	Continues.	Operation	The relevant instruction will end according to specifications.		
System-defined variables	Variable		Data type		Name	
	None		---		---	
Cause and correction	Assumed cause		Correction		Prevention	
	Data of a size that is different from the size of the target parameter was specified for the input or in-out data of an instruction.		Check the size of the target parameter and correct the program so that the size of the input data is the same.		Check the size of the target parameter and write the program so that the size of the input data is the same.	
Attached information	<p>Attached Information 1: Error Location</p> <p>Attached Information 2: Error Location Details (Rung Number). For a program section, the rung number from the start of the section is given. For ST, the line number is given.</p> <p>Attached Information 3: Names of the Instruction and Instruction Instance Where the Error Occurred. If there is more than one possible instruction, information is given on all of them. Nothing is given if the instruction cannot be identified.</p> <p>Attached Information 4: Expansion Error Code (<i>ErrorIDEx</i>)</p>					
Precautions/Remarks	If a program is changed after an error occurs, the attached information that is displayed may not be correct.					

* Error code 16#041C occurs for unit version 1.04 or later of the CPU Unit.

Event name	Exceeded Simultaneous Instruction Executed Resources		Event code	5401041D hex*		
Meaning	The maximum resources that you can use for the relevant instruction group at the same time was exceeded.					
Source	PLC Function Module		Source details	Instruction	Detection timing	At instruction execution
Error attributes	Level	Observation	Recovery	---	Log category	System
Effects	User program	Continues.	Operation	The relevant instruction will end according to specifications.		
System-defined variables	Variable		Data type		Name	
	None		---		---	
Cause and correction	Assumed cause		Correction		Prevention	
	More than the maximum number of relevant instructions were executed at the same time.		Correct the program so that no more than the maximum number of the relevant instructions are executed at the same time.		Write the program so that no more than the maximum number of the relevant instructions are executed at the same time.	
Attached information	<p>Attached Information 1: Error Location</p> <p>Attached Information 2: Error Location Details (Rung Number). For a program section, the rung number from the start of the section is given. For ST, the line number is given.</p> <p>Attached Information 3: Names of the Instruction and Instruction Instance Where the Error Occurred. If there is more than one possible instruction, information is given on all of them. Nothing is given if the instruction cannot be identified.</p> <p>Attached Information 4: Expansion Error Code (<i>ErrorIDEx</i>)</p>					
Precautions/Remarks	If a program is changed after an error occurs, the attached information that is displayed may not be correct.					

* Error code 16#041D occurs for unit version 1.05 or later of the CPU Unit.

Event name	FINS Error		Event code	54010800 hex		
Meaning	An error occurred when a FINS command was sent or received.					
Source	PLC Function Module		Source details	Instruction	Detection timing	At instruction execution
Error attributes	Level	Observation	Recovery	---	Log category	System
Effects	User program	Continues.	Operation	The relevant instruction will end according to specifications.		
System-defined variables	Variable		Data type		Name	
	None		---		---	
Cause and correction	Assumed cause		Correction		Prevention	
	An error occurred when a FINS command was sent or received.		Check the value of the <i>ErrorIDEx</i> output variable from the instruction and refer to the description in this manual for the communications response code (<i>ErrorIDEx</i>) with the same value for the instruction.		Read the description of <i>ErrorIDEx</i> in advance for the instruction and program correctly.	
Attached information	<p>Attached Information 1: Error Location</p> <p>Attached Information 2: Error Location Details (Rung Number). For a program section, the rung number from the start of the section is given. For ST, the line number is given.</p> <p>Attached Information 3: Names of the Instruction and Instruction Instance Where the Error Occurred. If there is more than one possible instruction, information is given on all of them. Nothing is given if the instruction cannot be identified.</p> <p>Attached Information 4: Expansion Error Code (<i>ErrorIDEx</i>)</p>					
Precautions/Remarks	If a program is changed after an error occurs, the attached information that is displayed may not be correct.					

Event name	FINS Port Already in Use			Event code	54010801 hex	
Meaning	The FINS port is being used.					
Source	PLC Function Module		Source details	Instruction	Detection timing	At instruction execution
Error attributes	Level	Observation	Recovery	---	Log category	System
Effects	User program	Continues.	Operation	The relevant instruction will end according to specifications. The communications output or Unit operation is not affected.		
System-defined variables	Variable		Data type		Name	
	None		---		---	
Cause and correction	Assumed cause		Correction		Prevention	
	The FINS port is being used.		Correct the program by inserting <i>_Port.isAvailable</i> in a N.O. input condition.		Insert <i>_Port.isAvailable</i> in a N.O. input condition when you create the program.	
Attached information	<p>Attached Information 1: Error Location</p> <p>Attached Information 2: Error Location Details (Rung Number). For a program section, the rung number from the start of the section is given. For ST, the line number is given.</p> <p>Attached Information 3: Names of the Instruction and Instruction Instance Where the Error Occurred. If there is more than one possible instruction, information is given on all of them. Nothing is given if the instruction cannot be identified.</p> <p>Attached Information 4: Expansion Error Code (<i>ErrorIDEx</i>)</p>					
Precautions/Remarks	If a program is changed after an error occurs, the attached information that is displayed may not be correct.					

Event name	Illegal Serial Communications Mode			Event code	54010C00 hex	
Meaning	The Serial Communications Unit is not in the serial communications mode required to execute an instruction.					
Source	PLC Function Module		Source details	Instruction	Detection timing	At instruction execution
Error attributes	Level	Observation	Recovery	---	Log category	System
Effects	User program	Continues.	Operation	The relevant instruction will end according to specifications. The communications output will follow the specifications of the instruction. The operation of the Unit is not affected.		
System-defined variables	Variable		Data type		Name	
	None		---		---	
Cause and correction	Assumed cause		Correction		Prevention	
	The serial communications port for the Serial Communications Unit is not set to the mode expected by the instruction.		Change to the serial communications mode required to execute the instruction. Or, correct the program so that it only uses instructions that can be executed in the current mode.		Set the Serial Communications Unit to the serial communications mode required to execute the instruction. Or, correct the program so that it only uses instructions that can be executed in the currently set mode.	
Attached information	<p>Attached Information 1: Error Location</p> <p>Attached Information 2: Error Location Details (Rung Number). For a program section, the rung number from the start of the section is given. For ST, the line number is given.</p> <p>Attached Information 3: Names of the Instruction and Instruction Instance Where the Error Occurred. If there is more than one possible instruction, information is given on all of them. Nothing is given if the instruction cannot be identified.</p> <p>Attached Information 4: Expansion Error Code (<i>ErrorIDEx</i>)</p>					
Precautions/Remarks	If a program is changed after an error occurs, the attached information that is displayed may not be correct.					

Event name	Full Reception Buffer		Event code	54010C03 hex *		
Meaning	The reception buffer is full.					
Source	PLC Function Module		Source details	Instruction	Detection timing	At instruction execution
Error attributes	Level	Observation	Recovery	---	Log category	System
Effects	User program	Continues.	Operation	The relevant instruction will end according to specifications. Even if the instruction was ended by this error, the received data is saved partially for the amount the receive data storage can store.		
System-defined variables	Variable		Data type		Name	
	None		---		---	
Cause and correction	Assumed cause		Correction		Prevention	
	<p>The reception buffer is full due to the following causes.</p> <ul style="list-style-type: none"> The transmission frequency of the remote device is high. The baud rate is too high. The reception processing frequency from the buffer is low. 		<p>Take either or all of the following correction measures and ensure that the reception buffer will not be full.</p> <ul style="list-style-type: none"> Lower the transmission frequency of the remote device. Decrease the baud rate. Increase the reception processing frequency from the buffer. 		<p>Consider the following four factors and ensure that the reception buffer will not be full.</p> <ul style="list-style-type: none"> Transmission frequency of the remote device Baud rate Reception processing frequency from the buffer Using flow control 	
Attached information	<p>Attached Information 1: Error Location</p> <p>Attached Information 2: Error Location Details (Rung Number). For a program section, the rung number from the start of the section is given. For ST, the line number is given.</p> <p>Attached Information 3: Names of the Instruction and Instruction Instance Where the Error Occurred. If there is more than one possible instruction, information is given on all of them. Nothing is given if the instruction cannot be identified.</p> <p>Attached Information 4: Expansion Error Code (<i>ErrorIDEx</i>)</p>					
Precautions/Remarks	If a program is changed after an error occurs, the attached information that is displayed may not be correct.					

* Error code 16#0C03 occurs for unit version 1.11 or later of the CPU Unit.

Event name	Multi-execution of Ports		Event code	54010C04 hex *		
Meaning	The serial communications instructions that cannot be executed simultaneously were executed.					
Source	PLC Function Module		Source details	Instruction	Detection timing	At instruction execution
Error attributes	Level	Observation	Recovery	---	Log category	System
Effects	User program	Continues.	Operation	The relevant instruction will end according to specifications. The communications output will follow the specifications of the instruction.		
System-defined variables	Variable		Data type		Name	
	None		---		---	
Cause and correction	Assumed cause		Correction		Prevention	
	<p>An instruction was executed while another instruction that cannot be executed at the same time with the former instruction was executed.</p>		<p>Correct the program so that instructions that cannot be executed at the same time are mutually excluded.</p>		<p>Create a program so that instructions that cannot be executed at the same time are mutually excluded.</p>	
Attached information	<p>Attached Information 1: Error Location</p> <p>Attached Information 2: Error Location Details (Rung Number). For a program section, the rung number from the start of the section is given. For ST, the line number is given.</p> <p>Attached Information 3: Names of the Instruction and Instruction Instance Where the Error Occurred. If there is more than one possible instruction, information is given on all of them. Nothing is given if the instruction cannot be identified.</p> <p>Attached Information 4: Expansion Error Code (<i>ErrorIDEx</i>)</p>					
Precautions/Remarks	<ul style="list-style-type: none"> If a program is changed after an error occurs, the attached information that is displayed may not be correct. Refer to individual instruction descriptions for the serial communications instructions that cannot be executed at the same time. 					

* Error code 16#0C04 occurs for unit version 1.11 or later of the CPU Unit.

Event name	Parity Error			Event code	54010C05 hex *	
Meaning	A parity error occurred in the data received.					
Source	PLC Function Module		Source details	Instruction	Detection timing	At instruction execution
Error attributes	Level	Observation	Recovery	---	Log category	System
Effects	User program	Continues.	Operation	The relevant instruction will end according to specifications. The communications output will follow the specifications of the instruction.		
System-defined variables	Variable		Data type		Name	
	None		---		---	
Cause and correction	Assumed cause		Correction		Prevention	
	The communications settings or baud rate settings are not compatible with the remote device.		Make the communications settings and baud rate settings compatible with the remote device.		Make the communications settings and baud rate settings compatible with the remote device.	
	Noise		Implement noise countermeasures.		Implement noise countermeasures.	
Attached information	<p>Attached Information 1: Error Location</p> <p>Attached Information 2: Error Location Details (Rung Number). For a program section, the rung number from the start of the section is given. For ST, the line number is given.</p> <p>Attached Information 3: Names of the Instruction and Instruction Instance Where the Error Occurred. If there is more than one possible instruction, information is given on all of them. Nothing is given if the instruction cannot be identified.</p> <p>Attached Information 4: Expansion Error Code (<i>ErrorIDEx</i>)</p>					
Precautions/Remarks	If a program is changed after an error occurs, the attached information that is displayed may not be correct.					

* Error code 16#0C05 occurs for unit version 1.11 or later of the CPU Unit.

Event name	Framing Error			Event code	54010C06 hex *	
Meaning	A framing error occurred in the data received.					
Source	PLC Function Module		Source details	Instruction	Detection timing	At instruction execution
Error attributes	Level	Observation	Recovery	---	Log category	System
Effects	User program	Continues.	Operation	The relevant instruction will end according to specifications. The communications output will follow the specifications of the instruction.		
System-defined variables	Variable		Data type		Name	
	None		---		---	
Cause and correction	Assumed cause		Correction		Prevention	
	The communications settings or baud rate settings are not compatible with the remote device.		Make the communications settings and baud rate settings compatible with the remote device.		Make the communications settings and baud rate settings compatible with the remote device.	
	Noise		Implement noise countermeasures.		Implement noise countermeasures.	
Attached information	<p>Attached Information 1: Error Location</p> <p>Attached Information 2: Error Location Details (Rung Number). For a program section, the rung number from the start of the section is given. For ST, the line number is given.</p> <p>Attached Information 3: Names of the Instruction and Instruction Instance Where the Error Occurred. If there is more than one possible instruction, information is given on all of them. Nothing is given if the instruction cannot be identified.</p> <p>Attached Information 4: Expansion Error Code (<i>ErrorIDEx</i>)</p>					
Precautions/Remarks	If a program is changed after an error occurs, the attached information that is displayed may not be correct.					

* Error code 16#0C06 occurs for unit version 1.11 or later of the CPU Unit.

Event name	Overrun Error			Event code	54010C07 hex *	
Meaning	An overrun error occurred in the data received.					
Source	PLC Function Module		Source details	Instruction	Detection timing	At instruction execution
Error attributes	Level	Observation	Recovery	---	Log category	System
Effects	User program	Continues.	Operation	The relevant instruction will end according to specifications. The communications output will follow the specifications of the instruction.		
System-defined variables	Variable		Data type		Name	
	None		---		---	
Cause and correction	Assumed cause		Correction		Prevention	
	The next data was received during processing of received data because the baud rate is too high.		Reduce the baud rate.		Reduce the baud rate.	
Attached information	<p>Attached Information 1: Error Location</p> <p>Attached Information 2: Error Location Details (Rung Number). For a program section, the rung number from the start of the section is given. For ST, the line number is given.</p> <p>Attached Information 3: Names of the Instruction and Instruction Instance Where the Error Occurred. If there is more than one possible instruction, information is given on all of them. Nothing is given if the instruction cannot be identified.</p> <p>Attached Information 4: Expansion Error Code (<i>ErrorIDEx</i>)</p>					
Precautions/Remarks	If a program is changed after an error occurs, the attached information that is displayed may not be correct.					

* Error code 16#0C07 occurs for unit version 1.11 or later of the CPU Unit.

Event name	CRC Mismatch			Event code	54010C08 hex *	
Meaning	The receive data had different CRC.					
Source	PLC Function Module		Source details	Instruction	Detection timing	At instruction execution
Error attributes	Level	Observation	Recovery	---	Log category	System
Effects	User program	Continues.	Operation	The relevant instruction will end according to specifications. The communications output will follow the specifications of the instruction.		
System-defined variables	Variable		Data type		Name	
	None		---		---	
Cause and correction	Assumed cause		Correction		Prevention	
	A wrong message was received.		Correct the CRC generation method for the remote device to be the one as intended.		Confirm the CRC generation method for the remote device to be the one as intended.	
	Noise		Receive the data again. Or, implement noise countermeasures.		Implement noise countermeasures.	
Attached information	<p>Attached Information 1: Error Location</p> <p>Attached Information 2: Error Location Details (Rung Number). For a program section, the rung number from the start of the section is given. For ST, the line number is given.</p> <p>Attached Information 3: Names of the Instruction and Instruction Instance Where the Error Occurred. If there is more than one possible instruction, information is given on all of them. Nothing is given if the instruction cannot be identified.</p> <p>Attached Information 4: Expansion Error Code (<i>ErrorIDEx</i>)</p>					
Precautions/Remarks	If a program is changed after an error occurs, the attached information that is displayed may not be correct.					

* Error code 16#0C08 occurs for unit version 1.11 or later of the CPU Unit.

*

Event name	Serial Communications Timeout			Event code	54010C0B hex *	
Meaning	A timeout occurred in serial communications.					
Source	PLC Function Module		Source details	Instruction	Detection timing	At instruction execution
Error attributes	Level	Observation	Recovery	---	Log category	System
Effects	User program	Continues.	Operation	The relevant instruction will end according to specifications. The communications output will follow the specifications of the instruction.		
System-defined variables	Variable		Data type		Name	
	None		---		---	
Cause and correction	Assumed cause		Correction		Prevention	
	Wiring to the remote device is not connected.		Check the wiring to the remote device and correct the wiring if there are any problems.		Confirm that wiring to the remote device is connected.	
	Power to the remote device is OFF.		Turn ON the power to the remote device.		Confirm that the power to the remote device is turned ON.	
	The communications settings or baud rate settings are not compatible with the remote device.		Make the communications settings and baud rate settings compatible with the remote device.		Make the communications settings and baud rate settings compatible with the remote device.	
	Noise		Implement noise countermeasures.		Implement noise countermeasures.	
Attached information	<p>Attached Information 1: Error Location</p> <p>Attached Information 2: Error Location Details (Rung Number). For a program section, the rung number from the start of the section is given. For ST, the line number is given.</p> <p>Attached Information 3: Names of the Instruction and Instruction Instance Where the Error Occurred. If there is more than one possible instruction, information is given on all of them. Nothing is given if the instruction cannot be identified.</p> <p>Attached Information 4: Expansion Error Code (<i>ErrorIDEx</i>)</p>					
Precautions/Remarks	If a program is changed after an error occurs, the attached information that is displayed may not be correct.					

* Error code 16#0C0B occurs for unit version 1.11 or later of the CPU Unit.

Event name	Instruction Executed to Inapplicable Port			Event code	54010C0C hex *	
Meaning	An instruction was executed to an inapplicable port.					
Source	PLC Function Module		Source details	Instruction	Detection timing	At instruction execution
Error attributes	Level	Observation	Recovery	---	Log category	System
Effects	User program	Continues.	Operation	The relevant instruction will end according to specifications. The communications output will follow the specifications of the instruction.		
System-defined variables	Variable		Data type		Name	
	None		---		---	
Cause and correction	Assumed cause		Correction		Prevention	
	An instruction was executed to an inapplicable port.		Specify a port that is applicable for the instruction, from the device port structure, and execute the instruction.		Specify a port that is applicable for the instruction, from the device port structure, and execute the instruction.	
Attached information	<p>Attached Information 1: Error Location</p> <p>Attached Information 2: Error Location Details (Rung Number). For a program section, the rung number from the start of the section is given. For ST, the line number is given.</p> <p>Attached Information 3: Names of the Instruction and Instruction Instance Where the Error Occurred. If there is more than one possible instruction, information is given on all of them. Nothing is given if the instruction cannot be identified.</p> <p>Attached Information 4: Expansion Error Code (<i>ErrorIDEx</i>)</p>					
Precautions/Remarks	If a program is changed after an error occurs, the attached information that is displayed may not be correct.					

* Error code 16#0C0C occurs for unit version 1.11 or later of the CPU Unit.

Event name	CIF Unit Initialized		Event code	54010C0D hex *1		
Meaning	A CIF Unit was initialized, so the communications data buffered in the CIF Unit was lost.					
Source	PLC Function Module		Source details	Instruction	Detection timing	At instruction execution
Error attributes	Level	Observation	Recovery	---	Log category	System
Effects	User program	Continues.	Operation	The relevant instruction will end according to specifications. The communications output will follow the specifications of the instruction.		
System-defined variables	Variable		Data type		Name	
	None		---		---	
Cause and correction	Assumed cause		Correction		Prevention	
	A CIF Unit was initialized.		Send or receive the data again, as required.		When a program that buffers communications data in a CIF Unit is executed, do not restart the CIF Unit.	
Attached information	Attached Information 1: Error Location Attached Information 2: Error Location Details (Rung Number). For a program section, the rung number from the start of the section is given. For ST, the line number is given. Attached Information 3: Names of the Instruction and Instruction Instance Where the Error Occurred. If there is more than one possible instruction, information is given on all of them. Nothing is given if the instruction cannot be identified. Attached Information 4: Expansion Error Code (<i>ErrorIDEx</i>)					
Precautions/Remarks	If a program is changed after an error occurs, the attached information that is displayed may not be correct.					

*1 Error code 16#0C0D occurs for unit version 1.13 or later of the CPU Unit.

Event name	Exceptional Modbus Response		Event code	54010C10 hex *		
Meaning	An exceptional code was returned from the Modbus slave.					
Source	PLC Function Module		Source details	Instruction	Detection timing	At instruction execution
Error attributes	Level	Observation	Recovery	---	Log category	System
Effects	User program	Continues.	Operation	The relevant instruction will end according to specifications. The communications output will follow the specifications of the instruction.		
System-defined variables	Variable		Data type		Name	
	None		---		---	
Cause and correction	Assumed cause		Correction		Prevention	
	An error was detected on the Modbus slave.		Check the value xx in 16#0000_00xx of <i>ErrorIDEx</i> , identify error causes in the Modbus Protocol, and take required measures. Refer to the description for the relevant instruction for the reference to the Modbus Protocol.		Write the user program, including ones for remote devices, according to the Modbus Protocol.	
Attached information	Attached Information 1: Error Location Attached Information 2: Error Location Details (Rung Number). For a program section, the rung number from the start of the section is given. For ST, the line number is given. Attached Information 3: Names of the Instruction and Instruction Instance Where the Error Occurred. If there is more than one possible instruction, information is given on all of them. Nothing is given if the instruction cannot be identified. Attached Information 4: Expansion Error Code (<i>ErrorIDEx</i>)					
Precautions/Remarks	If a program is changed after an error occurs, the attached information that is displayed may not be correct.					

* Error code 16#0C10 occurs for unit version 1.11 or later of the CPU Unit.

Event name	Invalid Modbus Response			Event code	54010C11 hex *	
Meaning	An unexpected response was returned from the Modbus slave.					
Source	PLC Function Module		Source details	Instruction	Detection timing	At instruction execution
Error attributes	Level	Observation	Recovery	---	Log category	System
Effects	User program	Continues.	Operation	The relevant instruction will end according to specifications. The communications output will follow the specifications of the instruction.		
System-defined variables	Variable		Data type		Name	
	None		---		---	
Cause and correction	Assumed cause		Correction		Prevention	
	The function code or data size of the response received from the Modbus slave was incorrect.		Review the transmission sequence with the remote devices, such as the send delay, reception monitoring time, and other options.		Write the user program so that the next command is not sent before a response is returned.	
Attached information	<p>Attached Information 1: Error Location</p> <p>Attached Information 2: Error Location Details (Rung Number). For a program section, the rung number from the start of the section is given. For ST, the line number is given.</p> <p>Attached Information 3: Names of the Instruction and Instruction Instance Where the Error Occurred. If there is more than one possible instruction, information is given on all of them. Nothing is given if the instruction cannot be identified.</p> <p>Attached Information 4: Expansion Error Code (<i>ErrorIDEx</i>)</p>					
Precautions/Remarks	If a program is changed after an error occurs, the attached information that is displayed may not be correct.					

* Error code 16#0C11 occurs for unit version 1.11 or later of the CPU Unit.

Event name	SD Memory Card Access Failure			Event code	54011400 hex	
Meaning	SD Memory Card access failed when an instruction was executed.					
Source	PLC Function Module		Source details	Instruction	Detection timing	At instruction execution
Error attributes	Level	Observation	Recovery	---	Log category	System
Effects	User program	Continues.	Operation	The relevant instruction will end according to specifications. The operation of the Unit is not affected.		
System-defined variables	Variable		Data type		Name	
	None		---		---	
Cause and correction	Assumed cause		Correction		Prevention	
	An SD Memory Card is either not inserted or is not inserted properly.		Insert the SD Memory Card correctly.		Make sure that the SD Memory Card is inserted properly.	
	The SD Memory Card is broken.		Replace the SD Memory Card with one that operates normally.		None	
	The SD Memory Card slot is broken.		If this error persists even after making the above two corrections, replace the CPU Unit.		None	
Attached information	<p>Attached Information 1: Error Location</p> <p>Attached Information 2: Error Location Details (Rung Number). For a program section, the rung number from the start of the section is given. For ST, the line number is given.</p> <p>Attached Information 3: Names of the Instruction and Instruction Instance Where the Error Occurred. If there is more than one possible instruction, information is given on all of them. Nothing is given if the instruction cannot be identified.</p> <p>Attached Information 4: Expansion Error Code (<i>ErrorIDEx</i>)</p>					
Precautions/Remarks	If a program is changed after an error occurs, the attached information that is displayed may not be correct.					

Event name	SD Memory Card Write-protected		Event code	54011401 hex		
Meaning	An attempt was made to write to a write-protected SD Memory Card when an instruction was executed.					
Source	PLC Function Module		Source details	Instruction	Detection timing	At instruction execution
Error attributes	Level	Observation	Recovery	---	Log category	System
Effects	User program	Continues.	Operation	The relevant instruction will end according to specifications. The operation of the Unit is not affected.		
System-defined variables	Variable		Data type		Name	
	None		---		---	
Cause and correction	Assumed cause		Correction		Prevention	
	An attempt was made to write to a write-protected SD Memory Card.		Remove write protection from the SD Memory Card. Slide the small switch on the side of the SD Memory Card from the LOCK position to the writable position.		Use an SD Memory Card that is not write-protected when writing to the SD Memory Card.	
Attached information	<p>Attached Information 1: Error Location</p> <p>Attached Information 2: Error Location Details (Rung Number). For a program section, the rung number from the start of the section is given. For ST, the line number is given.</p> <p>Attached Information 3: Names of the Instruction and Instruction Instance Where the Error Occurred. If there is more than one possible instruction, information is given on all of them. Nothing is given if the instruction cannot be identified.</p> <p>Attached Information 4: Expansion Error Code (<i>ErrorIDEx</i>)</p>					
Precautions/Remarks	If a program is changed after an error occurs, the attached information that is displayed may not be correct.					

Event name	SD Memory Card Insufficient Capacity		Event code	54011402 hex		
Meaning	The capacity of the SD Memory Card was insufficient when writing to the SD Memory Card for an instruction.					
Source	PLC Function Module		Source details	Instruction	Detection timing	At instruction execution
Error attributes	Level	Observation	Recovery	---	Log category	System
Effects	User program	Continues.	Operation	The relevant instruction will end according to specifications. The operation of the Unit is not affected.		
System-defined variables	Variable		Data type		Name	
	None		---		---	
Cause and correction	Assumed cause		Correction		Prevention	
	The SD Memory Card has run out of free space.		Replace the SD Memory Card for one with sufficient available capacity.		Use an SD Memory Card with sufficient available space when you add files to it.	
Attached information	<p>Attached Information 1: Error Location</p> <p>Attached Information 2: Error Location Details (Rung Number). For a program section, the rung number from the start of the section is given. For ST, the line number is given.</p> <p>Attached Information 3: Names of the Instruction and Instruction Instance Where the Error Occurred. If there is more than one possible instruction, information is given on all of them. Nothing is given if the instruction cannot be identified.</p> <p>Attached Information 4: Expansion Error Code (<i>ErrorIDEx</i>)</p>					
Precautions/Remarks	<ul style="list-style-type: none"> If a program is changed after an error occurs, the attached information that is displayed may not be correct. Do not remove the SD Memory Card during Card access. That may damage the SD Memory Card or corrupt the data on it. 					

Event name	File Does Not Exist			Event code	54011403 hex	
Meaning	The file specified for an instruction does not exist. Or, the specified file is corrupted.					
Source	PLC Function Module		Source details	Instruction	Detection timing	At instruction execution
Error attributes	Level	Observation	Recovery	---	Log category	System
Effects	User program	Continues.	Operation	The relevant instruction will end according to specifications. The operation of the Unit is not affected.		
System-defined variables	Variable		Data type		Name	
	None		---		---	
Cause and correction	Assumed cause		Correction		Prevention	
	The specified file does not exist.		Make sure that the filename that is specified for the instruction exists. Or, modify the filename so that it matches the filename specified for the instruction.		Make sure that the filename that is specified for the instruction exists.	
	The specified file is corrupted.		Specify the other filename.		None.	
	The SD Memory Card cannot be normally accessed due to a contact failure or other causes.		Insert the SD Memory Card again or replace it.		None.	
Attached information	<p>Attached Information 1: Error Location</p> <p>Attached Information 2: Error Location Details (Rung Number). For a program section, the rung number from the start of the section is given. For ST, the line number is given.</p> <p>Attached Information 3: Names of the Instruction and Instruction Instance Where the Error Occurred. If there is more than one possible instruction, information is given on all of them. Nothing is given if the instruction cannot be identified.</p> <p>Attached Information 4: Expansion Error Code (<i>ErrorIDEx</i>)</p>					
Precautions/Remarks	If a program is changed after an error occurs, the attached information that is displayed may not be correct.					

Event name	Too Many Files/ Directories			Event code	54011404 hex	
Meaning	The maximum number of files/directories was exceeded when creating a file/directory for an instruction.					
Source	PLC Function Module		Source details	Instruction	Detection timing	At instruction execution
Error attributes	Level	Observation	Recovery	---	Log category	System
Effects	User program	Continues.	Operation	The relevant instruction will end according to specifications. The operation of the Unit is not affected.		
System-defined variables	Variable		Data type		Name	
	None		---		---	
Cause and correction	Assumed cause		Correction		Prevention	
	The number of files or directories exceeded the maximum number.		Delete any unnecessary files and/or directories. Or, replace the SD Memory Card with one that has fewer files and directories compared to the maximum number of files and directories for FAT16 or FAT32.		Delete unnecessary files and directories so that there are not too many files and directories on the SD Memory Card. Regularly replace the SD Memory Card when the number of files grows constantly.	
Attached information	<p>Attached Information 1: Error Location</p> <p>Attached Information 2: Error Location Details (Rung Number). For a program section, the rung number from the start of the section is given. For ST, the line number is given.</p> <p>Attached Information 3: Names of the Instruction and Instruction Instance Where the Error Occurred. If there is more than one possible instruction, information is given on all of them. Nothing is given if the instruction cannot be identified.</p> <p>Attached Information 4: Expansion Error Code (<i>ErrorIDEx</i>)</p>					
Precautions/Remarks	If a program is changed after an error occurs, the attached information that is displayed may not be correct.					

Event name	File Already in Use		Event code	54011405 hex		
Meaning	A file specified for an instruction cannot be accessed because it is already being used.					
Source	PLC Function Module		Source details	Instruction	Detection timing	At instruction execution
Error attributes	Level	Observation	Recovery	---	Log category	System
Effects	User program	Continues.	Operation	The relevant instruction will end according to specifications. The operation of the Unit is not affected.		
System-defined variables	Variable		Data type		Name	
	None		---		---	
Cause and correction	Assumed cause		Correction		Prevention	
	An instruction attempted to read or write a file already being accessed by another instruction.		Correct the program so that the relevant instruction is only executed when the <i>Busy</i> output variable for all other instructions for the same file are FALSE.		When you execute multiple instructions that access the same file, write the program so that the instructions are not executed simultaneously. Make sure that the <i>Busy</i> output variable for all other instructions for the same file is FALSE.	
Attached information	<p>Attached Information 1: Error Location</p> <p>Attached Information 2: Error Location Details (Rung Number). For a program section, the rung number from the start of the section is given. For ST, the line number is given.</p> <p>Attached Information 3: Names of the Instruction and Instruction Instance Where the Error Occurred. If there is more than one possible instruction, information is given on all of them. Nothing is given if the instruction cannot be identified.</p> <p>Attached Information 4: Expansion Error Code (<i>ErrorIDEx</i>)</p>					
Precautions/Remarks	If a program is changed after an error occurs, the attached information that is displayed may not be correct.					

Event name	Open Mode Mismatch		Event code	54011406 hex		
Meaning	A file operation for an instruction was inconsistent with the open mode of the file.					
Source	PLC Function Module		Source details	Instruction	Detection timing	At instruction execution
Error attributes	Level	Observation	Recovery	---	Log category	System
Effects	User program	Continues.	Operation	The relevant instruction will end according to specifications. The operation of the Unit is not affected.		
System-defined variables	Variable		Data type		Name	
	None		---		---	
Cause and correction	Assumed cause		Correction		Prevention	
	The file open mode specified by the Open File instruction does not match the file operation attempted by a subsequent SD Memory Card instruction.		Correct the Open File instruction to open the file in an open mode that is suitable for the file operation.		Change the Open File instruction to open the file in an open mode that is suitable for the file operation.	
Attached information	<p>Attached Information 1: Error Location</p> <p>Attached Information 2: Error Location Details (Rung Number). For a program section, the rung number from the start of the section is given. For ST, the line number is given.</p> <p>Attached Information 3: Names of the Instruction and Instruction Instance Where the Error Occurred. If there is more than one possible instruction, information is given on all of them. Nothing is given if the instruction cannot be identified.</p> <p>Attached Information 4: Expansion Error Code (<i>ErrorIDEx</i>)</p>					
Precautions/Remarks	If a program is changed after an error occurs, the attached information that is displayed may not be correct.					

Event name	Offset Out of Range			Event code	54011407 hex	
Meaning	Access to the address is not possible for the offset specified for an instruction.					
Source	PLC Function Module		Source details	Instruction	Detection timing	At instruction execution
Error attributes	Level	Observation	Recovery	---	Log category	System
Effects	User program	Continues.	Operation	The relevant instruction will end according to specifications. The operation of the Unit is not affected.		
System-defined variables	Variable		Data type		Name	
	None		---		---	
Cause and correction	Assumed cause		Correction		Prevention	
	An attempt was made to access beyond the size of the file.		Decrease the offset specified for the instruction.		Include information in the file so that the file format can be identified, and modify the program to check that information in order to perform appropriate file seeking.	
Attached information	<p>Attached Information 1: Error Location</p> <p>Attached Information 2: Error Location Details (Rung Number). For a program section, the rung number from the start of the section is given. For ST, the line number is given.</p> <p>Attached Information 3: Names of the Instruction and Instruction Instance Where the Error Occurred. If there is more than one possible instruction, information is given on all of them. Nothing is given if the instruction cannot be identified.</p> <p>Attached Information 4: Expansion Error Code (<i>ErrorIDEx</i>)</p>					
Precautions/Remarks	If a program is changed after an error occurs, the attached information that is displayed may not be correct.					

Event name	Directory Not Empty			Event code	54011408 hex	
Meaning	A directory was not empty when the Delete Directory instruction was executed or when an attempt was made to change the directory name.					
Source	PLC Function Module		Source details	Instruction	Detection timing	At instruction execution
Error attributes	Level	Observation	Recovery	---	Log category	System
Effects	User program	Continues.	Operation	The relevant instruction will end according to specifications. The operation of the Unit is not affected.		
System-defined variables	Variable		Data type		Name	
	None		---		---	
Cause and correction	Assumed cause		Correction		Prevention	
	A directory was not empty when the Delete Directory instruction was executed.		Delete all files in the relevant directory.		Check the contents of a directory before you delete the directory using the Delete Directory instruction or before you change the directory name.	
	A directory contained another directory when an attempt was made to change the directory name.		Delete all directories from the relevant directory.			
Attached information	<p>Attached Information 1: Error Location</p> <p>Attached Information 2: Error Location Details (Rung Number). For a program section, the rung number from the start of the section is given. For ST, the line number is given.</p> <p>Attached Information 3: Names of the Instruction and Instruction Instance Where the Error Occurred. If there is more than one possible instruction, information is given on all of them. Nothing is given if the instruction cannot be identified.</p> <p>Attached Information 4: Expansion Error Code (<i>ErrorIDEx</i>)</p>					
Precautions/Remarks	If a program is changed after an error occurs, the attached information that is displayed may not be correct.					

Event name	That File Name Already Exists			Event code	54011409 hex	
Meaning	An instruction could not be executed because the file name specified for the instruction already exists.					
Source	PLC Function Module		Source details	Instruction	Detection timing	At instruction execution
Error attributes	Level	Observation	Recovery	---	Log category	System
Effects	User program	Continues.	Operation	The relevant instruction will end according to specifications. The operation of the Unit is not affected.		
System-defined variables	Variable		Data type		Name	
	None		---		---	
Cause and correction	Assumed cause		Correction		Prevention	
	A file already exists with the same name as the name specified for the instruction to create.		Correct the program so that the file-name specified for the instruction does not already exist. Or, delete the existing file.		Make sure that the file specified does not already exist when you create a file with an instruction.	
Attached information	<p>Attached Information 1: Error Location</p> <p>Attached Information 2: Error Location Details (Rung Number). For a program section, the rung number from the start of the section is given. For ST, the line number is given.</p> <p>Attached Information 3: Names of the Instruction and Instruction Instance Where the Error Occurred. If there is more than one possible instruction, information is given on all of them. Nothing is given if the instruction cannot be identified.</p> <p>Attached Information 4: Expansion Error Code (<i>ErrorIDEx</i>)</p>					
Precautions/Remarks	<ul style="list-style-type: none"> • If a program is changed after an error occurs, the attached information that is displayed may not be correct. • When you delete an existing file, check to make sure that you no longer need the file. 					

Event name	Write Access Denied			Event code	5401140A hex	
Meaning	An attempt was made to write to a write-protected file or directory when an instruction was executed.					
Source	PLC Function Module		Source details	Instruction	Detection timing	At instruction execution
Error attributes	Level	Observation	Recovery	---	Log category	System
Effects	User program	Continues.	Operation	The relevant instruction will end according to specifications. The operation of the Unit is not affected.		
System-defined variables	Variable		Data type		Name	
	None		---		---	
Cause and correction	Assumed cause		Correction		Prevention	
	The file or directory specified for the instruction to write is write-protected.		Remove write protection from the file or directory specified for the instruction. Or, change the filename of the file to write.		Do not write-protect any files that need to be written to.	
Attached information	<p>Attached Information 1: Error Location</p> <p>Attached Information 2: Error Location Details (Rung Number). For a program section, the rung number from the start of the section is given. For ST, the line number is given.</p> <p>Attached Information 3: Names of the Instruction and Instruction Instance Where the Error Occurred. If there is more than one possible instruction, information is given on all of them. Nothing is given if the instruction cannot be identified.</p> <p>Attached Information 4: Expansion Error Code (<i>ErrorIDEx</i>)</p>					
Precautions/Remarks	<ul style="list-style-type: none"> • If a program is changed after an error occurs, the attached information that is displayed may not be correct. • Before you remove write protection from a file, be sure it is OK to overwrite the file. 					

Event name	Too Many Files Open			Event code	5401140B hex	
Meaning	The maximum number of open files was exceeded when opening a file for an instruction.					
Source	PLC Function Module		Source details	Instruction	Detection timing	At instruction execution
Error attributes	Level	Observation	Recovery	---	Log category	System
Effects	User program	Continues.	Operation	The relevant instruction will end according to specifications. The operation of the Unit is not affected.		
System-defined variables	Variable		Data type		Name	
	None		---		---	
Cause and correction	Assumed cause		Correction		Prevention	
	The maximum number of open files was exceeded when opening a file for an instruction.		Correct the program to decrease the number of open files.		Decrease the number of files. Or, write the program so that files that no longer need to be open are closed in order to prevent too many files from being open at once.	
Attached information	<p>Attached Information 1: Error Location</p> <p>Attached Information 2: Error Location Details (Rung Number). For a program section, the rung number from the start of the section is given. For ST, the line number is given.</p> <p>Attached Information 3: Names of the Instruction and Instruction Instance Where the Error Occurred. If there is more than one possible instruction, information is given on all of them. Nothing is given if the instruction cannot be identified.</p> <p>Attached Information 4: Expansion Error Code (<i>ErrorIDEx</i>)</p>					
Precautions/Remarks	If a program is changed after an error occurs, the attached information that is displayed may not be correct.					

Event name	Directory Does Not Exist			Event code	5401140C hex	
Meaning	The directory specified for an instruction does not exist.					
Source	PLC Function Module		Source details	Instruction	Detection timing	At instruction execution
Error attributes	Level	Observation	Recovery	---	Log category	System
Effects	User program	Continues.	Operation	The relevant instruction will end according to specifications. The operation of the Unit is not affected.		
System-defined variables	Variable		Data type		Name	
	None		---		---	
Cause and correction	Assumed cause		Correction		Prevention	
	The directory specified for an instruction does not exist.		Correct the program so that the directory specified for the instruction exists. Or, create the relevant directory in advance.		Make sure that the directory specified for the instruction directory actually exists when using an instruction that accesses a directory.	
Attached information	<p>Attached Information 1: Error Location</p> <p>Attached Information 2: Error Location Details (Rung Number). For a program section, the rung number from the start of the section is given. For ST, the line number is given.</p> <p>Attached Information 3: Names of the Instruction and Instruction Instance Where the Error Occurred. If there is more than one possible instruction, information is given on all of them. Nothing is given if the instruction cannot be identified.</p> <p>Attached Information 4: Expansion Error Code (<i>ErrorIDEx</i>)</p>					
Precautions/Remarks	If a program is changed after an error occurs, the attached information that is displayed may not be correct.					

Event name	File or Directory Name Is Too Long			Event code	5401140D hex	
Meaning	The file name or directory name that was specified for an instruction is too long.					
Source	PLC Function Module		Source details	Instruction	Detection timing	At instruction execution
Error attributes	Level	Observation	Recovery	---	Log category	System
Effects	User program	Continues.	Operation	The relevant instruction will end according to specifications. The operation of the Unit is not affected.		
System-defined variables	Variable		Data type		Name	
	None		---		---	
Cause and correction	Assumed cause		Correction		Prevention	
	The file name or directory name that was specified for the instruction to create is too long.		Correct the program so that the file name or directory name specified for the instruction is within FAT16 or FAT32 restrictions.		Write the program so that the specified file names and directory names are within FAT16 or FAT32 restrictions.	
Attached information	<p>Attached Information 1: Error Location</p> <p>Attached Information 2: Error Location Details (Rung Number). For a program section, the rung number from the start of the section is given. For ST, the line number is given.</p> <p>Attached Information 3: Names of the Instruction and Instruction Instance Where the Error Occurred. If there is more than one possible instruction, information is given on all of them. Nothing is given if the instruction cannot be identified.</p> <p>Attached Information 4: Expansion Error Code (<i>ErrorIDEx</i>)</p>					
Precautions/Remarks	If a program is changed after an error occurs, the attached information that is displayed may not be correct.					

Event name	SD Memory Card Access Failed			Event code	5401140E hex	
Meaning	SD Memory Card access failed.					
Source	PLC Function Module		Source details	Instruction	Detection timing	At instruction execution
Error attributes	Level	Observation	Recovery	---	Log category	System
Effects	User program	Continues.	Operation	The relevant instruction will end according to specifications. The operation of the Unit is not affected.		
System-defined variables	Variable		Data type		Name	
	None		---		---	
Cause and correction	Assumed cause		Correction		Prevention	
	The SD Memory Card is broken.		Replace the SD Memory Card.		None	
	The SD Memory Card slot is broken.		If this error occurs even after making the above correction, replace the CPU Unit.		None	
Attached information	<p>Attached Information 1: Error Location</p> <p>Attached Information 2: Error Location Details (Rung Number). For a program section, the rung number from the start of the section is given. For ST, the line number is given.</p> <p>Attached Information 3: Names of the Instruction and Instruction Instance Where the Error Occurred. If there is more than one possible instruction, information is given on all of them. Nothing is given if the instruction cannot be identified.</p> <p>Attached Information 4: Expansion Error Code (<i>ErrorIDEx</i>)</p>					
Precautions/Remarks	If a program is changed after an error occurs, the attached information that is displayed may not be correct.					

Event name	Backup Operation Already in Progress			Event code	5401140F hex*	
Meaning	Another backup operation is already in progress.					
Source	PLC Function Module		Source details	Instruction	Detection timing	At instruction execution
Error attributes	Level	Observation	Recovery	---	Log category	System
Effects	User program	Continues.	Operation	The relevant instruction will end according to specifications. The operation of the Unit is not affected.		
System-defined variables	Variable		Data type		Name	
	None		---		---	
Cause and correction	Assumed cause		Correction		Prevention	
	Another backup operation is already in progress.		Wait for the backup operation to end and then execute the instruction again.		Do not attempt to execute other backup operation during a backup operation.	
Attached information	<p>Attached Information 1: Error Location</p> <p>Attached Information 2: Error Location Details (Rung Number). For a program section, the rung number from the start of the section is given. For ST, the line number is given.</p> <p>Attached Information 3: Names of the Instruction and Instruction Instance Where the Error Occurred. If there is more than one possible instruction, information is given on all of them. Nothing is given if the instruction cannot be identified.</p> <p>Attached Information 4: Expansion Error Code (<i>ErrorIDEx</i>)</p>					
Precautions/Remarks	If a program is changed after an error occurs, the attached information that is displayed may not be correct.					

* Error code 16#140F occurs for unit version 1.08 or later of the CPU Unit.

Event name	Cannot Execute Backup			Event code	54011410 hex*	
Meaning	Execution of a backup operation was not possible because execution of another operation was in progress.					
Source	PLC Function Module		Source details	Instruction	Detection timing	At instruction execution
Error attributes	Level	Observation	Recovery	---	Log category	System
Effects	User program	Continues.	Operation	The relevant instruction will end according to specifications. The operation of the Unit is not affected.		
System-defined variables	Variable		Data type		Name	
	None		---		---	
Cause and correction	Assumed cause		Correction		Prevention	
	Execution of the instruction was attempted during execution of online editing.		Complete online editing and then execute the instruction again.		Do not attempt to execute a backup operation during execution of online editing.	
	Execution of the instruction was attempted during execution of a Save Cam Table instruction.		Complete the Save Cam Table instruction and then execute the instruction again.		Do not attempt to execute a backup operation during execution of a Save Cam Table instruction.	
	Execution of the instruction was attempted while a CPU Unit name change operation was in progress.		Complete the CPU Unit name change and then execute the instruction again.		Do not attempt to execute a backup operation during execution of a CPU Unit name change.	
Attached information	<p>Attached Information 1: Error Location</p> <p>Attached Information 2: Error Location Details (Rung Number). For a program section, the rung number from the start of the section is given. For ST, the line number is given.</p> <p>Attached Information 3: Names of the Instruction and Instruction Instance Where the Error Occurred. If there is more than one possible instruction, information is given on all of them. Nothing is given if the instruction cannot be identified.</p> <p>Attached Information 4: Expansion Error Code (<i>ErrorIDEx</i>)</p>					
Precautions/Remarks	If a program is changed after an error occurs, the attached information that is displayed may not be correct.					

* Error code 16#1410 occurs for unit version 1.08 or later of the CPU Unit.

Event name	Unit/Slave Backup Failed		Event code	54011411 hex*		
Meaning	A Unit/slave backup operation failed.					
Source	PLC Function Module		Source details	Instruction	Detection timing	At instruction execution
Error attributes	Level	Observation	Recovery	---	Log category	System
Effects	User program	Continues.	Operation	The relevant instruction will end according to specifications. The operation of the Unit is not affected.		
System-defined variables	Variable		Data type		Name	
	None		---		---	
Cause and correction	Assumed cause		Correction		Prevention	
	A Unit/slave backup operation failed.		Refer to the corrections for the following events: CJ-series Unit Backup Failed (102D0000 hex) or EtherCAT Slave Backup Failed (102F0000 hex).		Refer to the preventive measures for the following events: CJ-series Unit Backup Failed (102D0000 hex) or EtherCAT Slave Backup Failed (102F0000 hex).	
Attached information	<p>Attached Information 1: Error Location</p> <p>Attached Information 2: Error Location Details (Rung Number). For a program section, the rung number from the start of the section is given. For ST, the line number is given.</p> <p>Attached Information 3: Names of the Instruction and Instruction Instance Where the Error Occurred. If there is more than one possible instruction, information is given on all of them. Nothing is given if the instruction cannot be identified.</p> <p>Attached Information 4: Expansion Error Code (<i>ErrorIDEx</i>)</p>					
Precautions/Remarks	If a program is changed after an error occurs, the attached information that is displayed may not be correct.					

* Error code 16#1411 occurs for unit version 1.08 or later of the CPU Unit.

Event name	Inapplicable SD Card		Event code	54011412 hex		
Meaning	The target SD Card does not support VUC.					
Source	PLC Function Module		Source details	Instruction	Detection timing	At instruction execution
Error attributes	Level	Observation	Recovery	---	Log category	System
Effects	User program	Continues.	Operation	The relevant instruction will end according to specifications. The operation of the Unit is not affected.		
System-defined variables	Variable		Data type		Name	
	None		---		---	
Cause and correction	Assumed cause		Correction		Prevention	
	The target SD Card dose not support VUC.		Replace the SD Card to the one that supports VUC.		Use the SD Card that supports VUC when the relevant instruction is used.	
Attached information	<p>Attached Information 1: Error Location</p> <p>Attached Information 2: Error Location Details (Rung Number). For a program section, the rung number from the start of the section is given. For ST, the line number is given.</p> <p>Attached Information 3: Names of the Instruction and Instruction Instance Where the Error Occurred. If there is more than one possible instruction, information is given on all of them. Nothing is given if the instruction cannot be identified.</p> <p>Attached Information 4: Expansion Error Code (<i>ErrorIDEx</i>)</p>					
Precautions/Remarks	If a program is changed after an error occurs, the attached information that is displayed may not be correct.					

Event name	EtherCAT Communications Error			Event code	54011800 hex	
Meaning	Accessing the EtherCAT network failed when an instruction was executed.					
Source	PLC Function Module		Source details	Instruction	Detection timing	At instruction execution
Error attributes	Level	Observation	Recovery	---	Log category	System
Effects	User program	Continues.	Operation	The relevant instruction will end according to specifications.		
System-defined variables	Variable		Data type		Name	
	None		---		---	
Cause and correction	Assumed cause		Correction		Prevention	
	The EtherCAT network is not in a usable status.		Check the operation status of the EtherCAT network by checking the status of the EtherCAT master. Use this information to correct the cause of the problem.		Depends on the nature of the error.	
Attached information	<p>Attached Information 1: Error Location</p> <p>Attached Information 2: Error Location Details (Rung Number). For a program section, the rung number from the start of the section is given. For ST, the line number is given.</p> <p>Attached Information 3: Names of the Instruction and Instruction Instance Where the Error Occurred. If there is more than one possible instruction, information is given on all of them. Nothing is given if the instruction cannot be identified.</p> <p>Attached Information 4: Expansion Error Code (<i>ErrorIDEx</i>)</p>					
Precautions/Remarks	If a program is changed after an error occurs, the attached information that is displayed may not be correct.					

Event name	EtherCAT Slave Does Not Respond			Event code	54011801 hex	
Meaning	Accessing the target slave failed when an instruction was executed.					
Source	PLC Function Module		Source details	Instruction	Detection timing	At instruction execution
Error attributes	Level	Observation	Recovery	---	Log category	System
Effects	User program	Continues.	Operation	The relevant instruction will end according to specifications.		
System-defined variables	Variable		Data type		Name	
	None		---		---	
Cause and correction	Assumed cause		Correction		Prevention	
	The target slave does not exist.		Specify an existing node address.		Specify an existing node address for the target slave.	
	The target slave is not in an operating condition.		Check the status of the target EtherCAT slave. Make sure that the target slave is in a usable status.		Make sure that the target slave is in a usable status.	
Attached information	<p>Attached Information 1: Error Location</p> <p>Attached Information 2: Error Location Details (Rung Number). For a program section, the rung number from the start of the section is given. For ST, the line number is given.</p> <p>Attached Information 3: Names of the Instruction and Instruction Instance Where the Error Occurred. If there is more than one possible instruction, information is given on all of them. Nothing is given if the instruction cannot be identified.</p> <p>Attached Information 4: Expansion Error Code (<i>ErrorIDEx</i>)</p>					
Precautions/Remarks	If a program is changed after an error occurs, the attached information that is displayed may not be correct.					

Event name	EtherCAT Timeout			Event code	54011802 hex	
Meaning	A timeout occurred while trying to access an EtherCAT slave when an instruction was executed.					
Source	PLC Function Module		Source details	Instruction	Detection timing	At instruction execution
Error attributes	Level	Observation	Recovery	---	Log category	System
Effects	User program	Continues.	Operation	The relevant instruction will end according to specifications.		
System-defined variables	Variable		Data type		Name	
	None		---		---	
Cause and correction	Assumed cause		Correction		Prevention	
	Communications with the target slave timed out.		Check the operating status of the target slave and correct the cause of the problem.		Depends on the nature of the error.	
Attached information	<p>Attached Information 1: Error Location</p> <p>Attached Information 2: Error Location Details (Rung Number). For a program section, the rung number from the start of the section is given. For ST, the line number is given.</p> <p>Attached Information 3: Names of the Instruction and Instruction Instance Where the Error Occurred. If there is more than one possible instruction, information is given on all of them. Nothing is given if the instruction cannot be identified.</p> <p>Attached Information 4: Expansion Error Code (<i>ErrorIDEx</i>)</p>					
Precautions/Remarks	If a program is changed after an error occurs, the attached information that is displayed may not be correct.					

Event name	Reception Buffer Overflow			Event code	54011803 hex	
Meaning	The receive data from an EtherCAT slave overflowed the receive buffer when an instruction was executed.					
Source	PLC Function Module		Source details	Instruction	Detection timing	At instruction execution
Error attributes	Level	Observation	Recovery	---	Log category	System
Effects	User program	Continues.	Operation	The relevant instruction will end according to specifications. It will not be possible to receive data from the slave.		
System-defined variables	Variable		Data type		Name	
	None		---		---	
Cause and correction	Assumed cause		Correction		Prevention	
	The receive data from the slave overflowed the receive buffer.		Set the size of the reception buffer to a value larger than the size of the receive data from the slave.		Set the size of the receive buffer to a value larger than the size of the receive data from the slave.	
Attached information	<p>Attached Information 1: Error Location</p> <p>Attached Information 2: Error Location Details (Rung Number). For a program section, the rung number from the start of the section is given. For ST, the line number is given.</p> <p>Attached Information 3: Names of the Instruction and Instruction Instance Where the Error Occurred. If there is more than one possible instruction, information is given on all of them. Nothing is given if the instruction cannot be identified.</p> <p>Attached Information 4: Expansion Error Code (<i>ErrorIDEx</i>)</p>					
Precautions/Remarks	If a program is changed after an error occurs, the attached information that is displayed may not be correct.					

Event name	SDO Abort Error			Event code	54011804 hex	
Meaning	An SDO abort error was received from an EtherCAT slave when an instruction was executed.					
Source	PLC Function Module		Source details	Instruction	Detection timing	At instruction execution
Error attributes	Level	Observation	Recovery	---	Log category	System
Effects	User program	Continues.	Operation	The relevant instruction will end according to specifications.		
System-defined variables	Variable		Data type		Name	
	None		---		---	
Cause and correction	Assumed cause		Correction		Prevention	
	Depends on the specifications of the slave.		Refer to the manual for the slave and correct the problem.		Refer to the manual for the slave and take the necessary steps to prevent the problem.	
Attached information	<p>Attached Information 1: Error Location</p> <p>Attached Information 2: Error Location Details (Rung Number). For a program section, the rung number from the start of the section is given. For ST, the line number is given.</p> <p>Attached Information 3: Names of the Instruction and Instruction Instance Where the Error Occurred. If there is more than one possible instruction, information is given on all of them. Nothing is given if the instruction cannot be identified.</p> <p>Attached Information 4: Expansion Error Code (<i>ErrorIDEx</i>)</p>					
Precautions/Remarks	If a program is changed after an error occurs, the attached information that is displayed may not be correct.					

Event name	Saving Packet Monitor File			Event code	54011805 hex	
Meaning	An instruction for packet monitoring was executed while saving an EtherCAT packet monitor file.					
Source	PLC Function Module		Source details	Instruction	Detection timing	At instruction execution
Error attributes	Level	Observation	Recovery	---	Log category	System
Effects	User program	Continues.	Operation	The relevant instruction will end according to specifications.		
System-defined variables	Variable		Data type		Name	
	None		---		---	
Cause and correction	Assumed cause		Correction		Prevention	
	An instruction for packet monitoring was executed while saving an EtherCAT packet monitor file.		Execute the instruction for packet monitoring after saving the EtherCAT packet monitor file is completed. You can check packet monitor file save status to see if saving a packet monitor file is completed.		Execute packet monitoring instructions only after the packet monitor file is saved. You can check packet monitor file save status to see if saving a packet monitor file is completed.	
Attached information	<p>Attached Information 1: Error Location</p> <p>Attached Information 2: Error Location Details (Rung Number). For a program section, the rung number from the start of the section is given. For ST, the line number is given.</p> <p>Attached Information 3: Names of the Instruction and Instruction Instance Where the Error Occurred. If there is more than one possible instruction, information is given on all of them. Nothing is given if the instruction cannot be identified.</p> <p>Attached Information 4: Expansion Error Code (<i>ErrorIDEx</i>)</p>					
Precautions/Remarks	If a program is changed after an error occurs, the attached information that is displayed may not be correct.					

Event name	Packet Monitoring Function Not Started		Event code	54011806 hex		
Meaning	A Stop EtherCAT Packet Monitor instruction was executed when EtherCAT packet monitoring was stopped.					
Source	PLC Function Module		Source details	Instruction	Detection timing	At instruction execution
Error attributes	Level	Observation	Recovery	---	Log category	System
Effects	User program	Continues.	Operation	The relevant instruction will end according to specifications.		
System-defined variables	Variable		Data type		Name	
	None		---		---	
Cause and correction	Assumed cause		Correction		Prevention	
	A Stop EtherCAT Packet Monitor instruction was executed when EtherCAT packet monitoring was stopped.		Execute the Stop EtherCAT Packet Monitor instruction after starting the packet monitoring function. You can check packet monitoring function operation status to see if the packet monitoring function is currently in operation.		Execute the Stop EtherCAT Packet Monitor instruction after starting the packet monitoring function. You can check packet monitoring function operation status to see if the packet monitoring function is currently in operation.	
Attached information	<p>Attached Information 1: Error Location</p> <p>Attached Information 2: Error Location Details (Rung Number). For a program section, the rung number from the start of the section is given. For ST, the line number is given.</p> <p>Attached Information 3: Names of the Instruction and Instruction Instance Where the Error Occurred. If there is more than one possible instruction, information is given on all of them. Nothing is given if the instruction cannot be identified.</p> <p>Attached Information 4: Expansion Error Code (<i>ErrorIDEx</i>)</p>					
Precautions/Remarks	If a program is changed after an error occurs, the attached information that is displayed may not be correct.					

Event name	Packet Monitoring Function in Operation		Event code	54011807 hex		
Meaning	A Start EtherCAT Packet Monitor instruction was executed when EtherCAT packet monitoring was already being executed.					
Source	PLC Function Module		Source details	Instruction	Detection timing	At instruction execution
Error attributes	Level	Observation	Recovery	---	Log category	System
Effects	User program	Continues.	Operation	The relevant instruction will end according to specifications.		
System-defined variables	Variable		Data type		Name	
	None		---		---	
Cause and correction	Assumed cause		Correction		Prevention	
	The Start EtherCAT Packet Monitor instruction was executed again while the EtherCAT packet monitoring function was already in operation.		Execute the Start EtherCAT Packet Monitor instruction after the packet monitoring function was stopped. You can check packet monitoring function operation status to see if the packet monitoring function is stopped.		Execute the Start EtherCAT Packet Monitor instruction after the packet monitoring function is stopped. You can check packet monitoring function operation status to see if the packet monitoring function is stopped.	
Attached information	<p>Attached Information 1: Error Location</p> <p>Attached Information 2: Error Location Details (Rung Number). For a program section, the rung number from the start of the section is given. For ST, the line number is given.</p> <p>Attached Information 3: Names of the Instruction and Instruction Instance Where the Error Occurred. If there is more than one possible instruction, information is given on all of them. Nothing is given if the instruction cannot be identified.</p> <p>Attached Information 4: Expansion Error Code (<i>ErrorIDEx</i>)</p>					
Precautions/Remarks	If a program is changed after an error occurs, the attached information that is displayed may not be correct.					

Event name	Communications Resource Overflow			Event code	54011808 hex	
Meaning	More than 32 EtherCAT communications instructions were executed at the same time.					
Source	PLC Function Module		Source details	Instruction	Detection timing	At instruction execution
Error attributes	Level	Observation	Recovery	---	Log category	System
Effects	User program	Continues.	Operation	The relevant instruction will end according to specifications.		
System-defined variables	Variable		Data type		Name	
	None		---		---	
Cause and correction	Assumed cause		Correction		Prevention	
	<p>More than 32 EtherCAT communications instructions were executed at the same time. The EtherCAT communications instructions are listed below.</p> <ul style="list-style-type: none"> • EC_CoESDOWrite instruction • EC_CoESDORead instruction • EC_ConnectSlave instruction • EC_DisconnectSlave instruction • EC_StartMon instruction • EC_SaveMon instruction • EC_StopMon instruction • EC_CopyMon instruction 		Correct the user program so that no more than 32 EtherCAT communications instructions are executed at the same time.		Write the user program so that no more than 32 EtherCAT communications instructions are executed at the same time.	
Attached information	<p>Attached Information 1: Error Location</p> <p>Attached Information 2: Error Location Details (Rung Number). For a program section, the rung number from the start of the section is given. For ST, the line number is given.</p> <p>Attached Information 3: Names of the Instruction and Instruction Instance Where the Error Occurred. If there is more than one possible instruction, information is given on all of them. Nothing is given if the instruction cannot be identified.</p> <p>Attached Information 4: Expansion Error Code (<i>ErrorIDEx</i>)</p>					
Precautions/Remarks	If a program is changed after an error occurs, the attached information that is displayed may not be correct.					

Event name	Packet Monitoring Function Not Supported			Event code	54011809 hex*	
Meaning	Packets cannot be monitored.					
Source	PLC Function Module		Source details	Instruction	Detection timing	At instruction execution
Error attributes	Level	Observation	Recovery	---	Log category	System
Effects	User program	Continues.	Operation	The relevant instruction will end according to specifications.		
System-defined variables	Variable		Data type		Name	
	None		---		---	
Cause and correction	Assumed cause		Correction		Prevention	
	An instruction for packet monitoring was executed for a CPU Unit that does not support packet monitoring.		Do not execute the EC_StartMon, EC_SaveMon, EC_StopMon, or EC_CopyMon instruction. If packet monitoring is required, use a CPU Unit that supports packet monitoring.		Do not execute instructions for packet monitoring for a CPU Unit that does not support packet monitoring.	
Attached information	<p>Attached Information 1: Error Location</p> <p>Attached Information 2: Error Location Details (Rung Number). For a program section, the rung number from the start of the section is given. For ST, the line number is given.</p> <p>Attached Information 3: Names of the Instruction and Instruction Instance Where the Error Occurred. If there is more than one possible instruction, information is given on all of them. Nothing is given if the instruction cannot be identified.</p> <p>Attached Information 4: Expansion Error Code (<i>ErrorIDEx</i>)</p>					
Precautions/Remarks	If a program is changed after an error occurs, the attached information that is displayed may not be correct.					

* Error code 16#1809 occurs for unit version 1.01 or later of the CPU Unit.

Event name	Explicit Message Error		Event code	54011C00 hex		
Meaning	An error response code was returned for an explicit message that was sent with a CIP communications instruction.					
Source	PLC Function Module		Source details	Instruction	Detection timing	At instruction execution
Error attributes	Level	Observation	Recovery	---	Log category	System
Effects	User program	Continues.	Operation	The relevant instruction will end according to specifications.		
System-defined variables	Variable		Data type		Name	
	None		---		---	
Cause and correction	Assumed cause		Correction		Prevention	
	Depends on the nature of the error.		Check the value of the <i>ErrorIDEx</i> output variable from the instruction and refer to the description in this manual of the CIP message error code.		Depends on the nature of the error. Refer to the description in this manual of the CIP message error code.	
Attached information	<p>Attached Information 1: Error Location</p> <p>Attached Information 2: Error Location Details (Rung Number). For a program section, the rung number from the start of the section is given. For ST, the line number is given.</p> <p>Attached Information 3: Names of the Instruction and Instruction Instance Where the Error Occurred. If there is more than one possible instruction, information is given on all of them. Nothing is given if the instruction cannot be identified.</p> <p>Attached Information 4: Expansion Error Code (<i>ErrorIDEx</i>)</p>					
Precautions/Remarks	If a program is changed after an error occurs, the attached information that is displayed may not be correct.					

Event name	Incorrect Route Path		Event code	54011C01 hex		
Meaning	The format of the route path that is specified for a CIP communications instruction is not correct.					
Source	PLC Function Module		Source details	Instruction	Detection timing	At instruction execution
Error attributes	Level	Observation	Recovery	---	Log category	System
Effects	User program	Continues.	Operation	The relevant instruction will end according to specifications.		
System-defined variables	Variable		Data type		Name	
	None		---		---	
Cause and correction	Assumed cause		Correction		Prevention	
	The format of the route path that is specified for a CIP communications instruction is not correct.		Correct the route path that is specified by the instruction.		Make sure that the instructions specify correct route paths.	
Attached information	<p>Attached Information 1: Error Location</p> <p>Attached Information 2: Error Location Details (Rung Number). For a program section, the rung number from the start of the section is given. For ST, the line number is given.</p> <p>Attached Information 3: Names of the Instruction and Instruction Instance Where the Error Occurred. If there is more than one possible instruction, information is given on all of them. Nothing is given if the instruction cannot be identified.</p> <p>Attached Information 4: Expansion Error Code (<i>ErrorIDEx</i>)</p>					
Precautions/Remarks	If a program is changed after an error occurs, the attached information that is displayed may not be correct.					

Event name	CIP Handle Out of Range			Event code	54011C02 hex	
Meaning	The handle that is specified for the CIP communications instruction is not correct.					
Source	PLC Function Module		Source details	Instruction	Detection timing	At instruction execution
Error attributes	Level	Observation	Recovery	---	Log category	System
Effects	User program	Continues.	Operation	The relevant instruction will end according to specifications.		
System-defined variables	Variable		Data type		Name	
	None		---		---	
Cause and correction	Assumed cause		Correction		Prevention	
	The handle that is specified for the CIP communications instruction is not correct.		Correct the handle for the instruction to the handle that was obtained with the CIPOpen instruction.		Specify handles that were obtained with the CIPOpen instruction.	
Attached information	<p>Attached Information 1: Error Location</p> <p>Attached Information 2: Error Location Details (Rung Number). For a program section, the rung number from the start of the section is given. For ST, the line number is given.</p> <p>Attached Information 3: Names of the Instruction and Instruction Instance Where the Error Occurred. If there is more than one possible instruction, information is given on all of them. Nothing is given if the instruction cannot be identified.</p> <p>Attached Information 4: Expansion Error Code (<i>ErrorIDEx</i>)</p>					
Precautions/Remarks	If a program is changed after an error occurs, the attached information that is displayed may not be correct.					

Event name	CIP Communications Resource Overflow			Event code	54011C03 hex	
Meaning	The maximum resources that you can use for CIP communications instructions at the same time was exceeded.					
Source	PLC Function Module		Source details	Instruction	Detection timing	At instruction execution
Error attributes	Level	Observation	Recovery	---	Log category	System
Effects	User program	Continues.	Operation	The relevant instruction will end according to specifications.		
System-defined variables	Variable		Data type		Name	
	None		---		---	
Cause and correction	Assumed cause		Correction		Prevention	
	More than 32 CIP communications instructions were executed at the same time.		Correct the user program so that no more than 32 CIP communications instructions are executed at the same time.		Write the user program so that no more than 32 CIP communications instructions are executed at the same time.	
	An attempt was made to use more than 32 handles at the same time.		Correct the user program so that no more than 32 handles are used at the same time.		Write the user program so that no more than 32 handles are used at the same time.	
Attached information	<p>Attached Information 1: Error Location</p> <p>Attached Information 2: Error Location Details (Rung Number). For a program section, the rung number from the start of the section is given. For ST, the line number is given.</p> <p>Attached Information 3: Names of the Instruction and Instruction Instance Where the Error Occurred. If there is more than one possible instruction, information is given on all of them. Nothing is given if the instruction cannot be identified.</p> <p>Attached Information 4: Expansion Error Code (<i>ErrorIDEx</i>)</p>					
Precautions/Remarks	If a program is changed after an error occurs, the attached information that is displayed may not be correct.					

Event name	CIP Timeout		Event code	54011C04 hex		
Meaning	A CIP timeout occurred during execution of a CIP communications instruction.					
Source	PLC Function Module		Source details	Instruction	Detection timing	At instruction execution
Error attributes	Level	Observation	Recovery	---	Log category	System
Effects	User program	Continues.	Operation	The relevant instruction will end according to specifications.		
System-defined variables	Variable		Data type		Name	
	None		---		---	
Cause and correction	Assumed cause		Correction		Prevention	
	A device does not exist for the specified IP address.		Correct the specified IP address to the IP address of the remote device.		Specify the correct IP address of the remote device.	
	The CIP connection for the specified handle timed out and was closed.		Execute the instruction before the connection times out. Or, increase the timeout time of the connection.		Execute the instruction before the connection times out.	
	Power to the remote device is OFF.		Check the status of the remote device and start it normally.		Check the status of the remote device and start it normally.	
	Communications are stopped at the remote device.					
	The Ethernet cable connector for EtherNet/IP is disconnected.		Reconnect the connector and make sure it is mated correctly.		Connect the connector securely.	
	The Ethernet cable for EtherNet/IP is disconnected.		Replace the Ethernet cable.		None	
Noise		Implement noise countermeasures if there is excessive noise.		Implement noise countermeasures if there is excessive noise.		
Attached information	<p>Attached Information 1: Error Location</p> <p>Attached Information 2: Error Location Details (Rung Number). For a program section, the rung number from the start of the section is given. For ST, the line number is given.</p> <p>Attached Information 3: Names of the Instruction and Instruction Instance Where the Error Occurred. If there is more than one possible instruction, information is given on all of them. Nothing is given if the instruction cannot be identified.</p> <p>Attached Information 4: Expansion Error Code (<i>ErrorIDEx</i>)</p>					
Precautions/Remarks	If a program is changed after an error occurs, the attached information that is displayed may not be correct.					

Event name	Class-3 Connection Not Established		Event code	54011C05 hex*		
Meaning	Establishing a class-3 connection failed for a CIP communications instruction.					
Source	PLC Function Module		Source details	Instruction	Detection timing	At instruction execution
Error attributes	Level	Observation	Recovery	---	Log category	System
Effects	User program	Continues.	Operation	The relevant instruction will end according to specifications.		
System-defined variables	Variable		Data type		Name	
	None		---		---	
Cause and correction	Assumed cause		Correction		Prevention	
	The CIPOpen instruction was executed for a device that does not support class 3 (Large_Forward_Open).		Correct the program to use the CIPOpenWithDataSize instruction for the device that does not support class 3 (Large_Forward_Open) and set the data size to less than 510 bytes.		Write the program to use the CIPOpenWithDataSize instruction for any device that does not support class 3 (Large_Forward_Open) and set the data size to less than 510 bytes.	
	The CIPOpenWithDataSize instruction was executed with a specified data size of 510 bytes or larger for a device that does not support class 3 (Large_Forward_Open).		Correct the program to set the data size to less than 510 bytes in the CIPOpenWithDataSize instruction for the device that does not support class 3 (Large_Forward_Open).		Write the program to set the data size to less than 510 bytes in the CIPOpenWithDataSize instruction for any device that does not support class 3 (Large_Forward_Open).	
Attached information	<p>Attached Information 1: Error Location</p> <p>Attached Information 2: Error Location Details (Rung Number). For a program section, the rung number from the start of the section is given. For ST, the line number is given.</p> <p>Attached Information 3: Name of the Instruction and Instruction Instance Where the Error Occurred. If there is more than one possible instruction, information is given on all of them. Nothing is given if the instruction cannot be identified.</p> <p>Attached Information 4: Expansion Error Code (<i>ErrorIDEx</i>)</p>					
Precautions/Remarks	If a program is changed after an error occurs, the attached information that is displayed may not be correct.					

* Error code 16#1C05 occurs for unit version 1.06 or later of the CPU Unit.

Event name	CIP Communications Data Size Exceeded		Event code	54011C06 hex*		
Meaning	An attempt was made to send a class-3 explicit message with a data size that is larger than the sendable size with a CIP communications instruction.					
Source	PLC Function Module		Source details	Instruction	Detection timing	At instruction execution
Error attributes	Level	Observation	Recovery	---	Log category	System
Effects	User program	Continues.	Operation	The relevant instruction will end according to specifications.		
System-defined variables	Variable		Data type		Name	
	None		---		---	
Cause and correction	Assumed cause		Correction		Prevention	
	The data size that was specified for the input variable to the CIPRead, CIPWrite, or CIPSend instruction exceeded the data size that was specified with the CIPOpenWithDataSize instruction.		Correct the program so that the data size of the relevant instruction does not exceed the data size that was set with the CIPOpenWithDataSize instruction. Or, set the data size of the CIPOpenWithDataSize instruction to the data size of the relevant instruction or larger to establish a connection.		Write the program so that the data size of the relevant instruction does not exceed the data size that was set with the CIPOpenWithDataSize instruction. Or, set the data size of the CIPOpenWithDataSize instruction to the data size of the relevant instruction or larger to establish a connection.	
Attached information	<p>Attached Information 1: Error Location</p> <p>Attached Information 2: Error Location Details (Rung Number). For a program section, the rung number from the start of the section is given. For ST, the line number is given.</p> <p>Attached Information 3: Name of the Instruction and Instruction Instance Where the Error Occurred. If there is more than one possible instruction, information is given on all of them. Nothing is given if the instruction cannot be identified.</p> <p>Attached Information 4: Expansion Error Code (<i>ErrorIDEx</i>)</p>					
Precautions/Remarks	If a program is changed after an error occurs, the attached information that is displayed may not be correct.					

* Error code 16#1C06 occurs for unit version 1.06 or later of the CPU Unit.

Event name	Local IP Address Setting Error		Event code	54012000 hex		
Meaning	An instruction was executed when there was a setting error in the local IP address.					
Source	PLC Function Module		Source details	Instruction	Detection timing	At instruction execution
Error attributes	Level	Observation	Recovery	---	Log category	System
Effects	User program	Continues.	Operation	The relevant instruction will end according to specifications.		
System-defined variables	Variable		Data type		Name	
	None		---		---	
Cause and correction	Assumed cause		Correction		Prevention	
	An instruction was executed when there was a setting error in the local IP address.		There was a TCP/IP Basic Setting Error (IP Address Setting Error) when the instruction was executed. Remove the cause of the TCP/IP Basic Setting Error.		Set the IP addresses correctly so that a TCP/IP Basic Setting Error does not occur.	
Attached information	<p>Attached Information 1: Error Location</p> <p>Attached Information 2: Error Location Details (Rung Number). For a program section, the rung number from the start of the section is given. For ST, the line number is given.</p> <p>Attached Information 3: Names of the Instruction and Instruction Instance Where the Error Occurred. If there is more than one possible instruction, information is given on all of them. Nothing is given if the instruction cannot be identified.</p> <p>Attached Information 4: Expansion Error Code (<i>ErrorIDEx</i>)</p>					
Precautions/Remarks	If a program is changed after an error occurs, the attached information that is displayed may not be correct.					

Event name	TCP/UDP Port Already in Use			Event code	54012001 hex	
Meaning	The UDP or TCP port was already in use when the instruction was executed.					
Source	PLC Function Module		Source details	Instruction	Detection timing	At instruction execution
Error attributes	Level	Observation	Recovery	---	Log category	System
Effects	User program	Continues.	Operation	The relevant instruction will end according to specifications.		
System-defined variables	Variable		Data type		Name	
	None		---		---	
Cause and correction	Assumed cause		Correction		Prevention	
	The UDP or TCP port is already in use.		Correct the user program so that an unused port is specified for the instruction.		Write the user program so that used ports are not specified for instructions.	
Attached information	<p>Attached Information 1: Error Location</p> <p>Attached Information 2: Error Location Details (Rung Number). For a program section, the rung number from the start of the section is given. For ST, the line number is given.</p> <p>Attached Information 3: Names of the Instruction and Instruction Instance Where the Error Occurred. If there is more than one possible instruction, information is given on all of them. Nothing is given if the instruction cannot be identified.</p> <p>Attached Information 4: Expansion Error Code (<i>ErrorIDEx</i>)</p>					
Precautions/Remarks	If a program is changed after an error occurs, the attached information that is displayed may not be correct.					

Event name	Address Resolution Failed			Event code	54012002 hex	
Meaning	Address resolution failed for a remote node with the host name that was specified in the instruction.					
Source	PLC Function Module		Source details	Instruction	Detection timing	At instruction execution
Error attributes	Level	Observation	Recovery	---	Log category	System
Effects	User program	Continues.	Operation	The relevant instruction will end according to specifications.		
System-defined variables	Variable		Data type		Name	
	None		---		---	
Cause and correction	Assumed cause		Correction		Prevention	
	The host name specified for the instruction is not correct.		Correct the host name that is specified in the instruction.		Specify correct host names in instructions.	
	The hosts and DNS settings in the Controller are incorrect.		Correct the hosts and DNS settings in the Controller.		Check the hosts and DNS settings in the Controller and make sure they are correct.	
	The DNS server settings are incorrect.		Correct the DNS server settings.		Check that there are no mistakes in the DNS server settings.	
Attached information	<p>Attached Information 1: Error Location</p> <p>Attached Information 2: Error Location Details (Rung Number). For a program section, the rung number from the start of the section is given. For ST, the line number is given.</p> <p>Attached Information 3: Names of the Instruction and Instruction Instance Where the Error Occurred. If there is more than one possible instruction, information is given on all of them. Nothing is given if the instruction cannot be identified.</p> <p>Attached Information 4: Expansion Error Code (<i>ErrorIDEx</i>)</p>					
Precautions/Remarks	If a program is changed after an error occurs, the attached information that is displayed may not be correct.					

Event name	Socket Status Error		Event code	54012003 hex		
Meaning	The status was not suitable for execution of the socket service instruction.					
Source	PLC Function Module		Source details	Instruction	Detection timing	At instruction execution
Error attributes	Level	Observation	Recovery	---	Log category	System
Effects	User program	Continues.	Operation	The relevant instruction will end according to specifications.		
System-defined variables	Variable		Data type		Name	
	None		---		---	

Cause and correction	Assumed cause	Correction	Prevention
	<ul style="list-style-type: none"> • SktUDPCreate Instruction The UDP port specified with the <i>SrcUdpPort</i> input variable is in one of the following states. <ul style="list-style-type: none"> • It is already open. • It is being closed. • SktUDPRcv Instruction <ul style="list-style-type: none"> • The specified socket is receiving data. • The specified socket is closed. • SktUDPSend Instruction <ul style="list-style-type: none"> • The specified socket is sending data. • The specified socket is closed. • SktTCPAccept Instruction The specified TCP port is in one of the following states. <ul style="list-style-type: none"> • The port is being opened. • The port is being closed. • A connection is already established for this instruction for the same IP address and TCP port. • SktTCPConnect Instruction <ul style="list-style-type: none"> • The TCP port that is specified with the <i>SrcTcpPort</i> input variable is already open. • The remote node that is specified with <i>DstAdr</i> input variable does not exist. • The remote node that is specified with <i>DstAdr</i> and <i>DstTcpPort</i> input variables is not waiting for a connection. • SktTCPRcv Instruction <ul style="list-style-type: none"> • The specified socket is receiving data. • The specified socket is closed. • SktTCPSEND Instruction <ul style="list-style-type: none"> • The specified socket is sending data. • The specified socket is closed. • The send buffer of the specified socket is full (because the power to the remote node is OFF, the line is disconnected, etc.) • SktSetOption Instruction <ul style="list-style-type: none"> • The specified socket already started transmission. • An option type which is not supported by the specified socket was selected. 	<p>Remove the cause of the error for the instruction.</p>	<p>Do not execute the instruction when it will cause an error.</p>
Attached information	<p>Attached Information 1: Error Location</p> <p>Attached Information 2: Error Location Details (Rung Number). For a program section, the rung number from the start of the section is given. For ST, the line number is given.</p> <p>Attached Information 3: Names of the Instruction and Instruction Instance Where the Error Occurred. If there is more than one possible instruction, information is given on all of them. Nothing is given if the instruction cannot be identified.</p> <p>Attached Information 4: Expansion Error Code (<i>ErrorIDEx</i>)</p>		
Precautions/Remarks	<p>If a program is changed after an error occurs, the attached information that is displayed may not be correct.</p>		

Event name	Local IP Address Not Set			Event code	54012004 hex	
Meaning	The local IP address was not set when a socket service instruction was executed.					
Source	PLC Function Module		Source details	Instruction	Detection timing	At instruction execution
Error attributes	Level	Observation	Recovery	---	Log category	System
Effects	User program	Continues.	Operation	The relevant instruction will end according to specifications.		
System-defined variables	Variable		Data type		Name	
	None		---		---	
Cause and correction	Assumed cause		Correction		Prevention	
	There is a BOOTP server setting error.		Correct any errors in the BOOTP server settings.		Check that there are no mistakes in the BOOTP server settings.	
	The BOOTP server does not exist.		Make sure that the BOOTP server has started normally and is normally connected to the network.		Make sure that the BOOTP server has started normally and is normally connected to the network.	
	The local IP address is not set because operation just started.		Wait until the local IP address is set before executing socket service instructions.		Wait until the local IP address is set before executing socket service instructions.	
Attached information	<p>Attached Information 1: Error Location</p> <p>Attached Information 2: Error Location Details (Rung Number). For a program section, the rung number from the start of the section is given. For ST, the line number is given.</p> <p>Attached Information 3: Names of the Instruction and Instruction Instance Where the Error Occurred. If there is more than one possible instruction, information is given on all of them. Nothing is given if the instruction cannot be identified.</p> <p>Attached Information 4: Expansion Error Code (<i>ErrorIDEx</i>)</p>					
Precautions/Remarks	If a program is changed after an error occurs, the attached information that is displayed may not be correct.					

Event name	Socket Timeout			Event code	54012006 hex	
Meaning	A timeout occurred for a socket service instruction.					
Source	PLC Function Module		Source details	Instruction	Detection timing	At instruction execution
Error attributes	Level	Observation	Recovery	---	Log category	System
Effects	User program	Continues.	Operation	The relevant instruction will end according to specifications.		
System-defined variables	Variable		Data type		Name	
	None		---		---	
Cause and correction	Assumed cause		Correction		Prevention	
	SkTTCPAccept instruction: There was no request for a connection from the remote node during the user-set timeout time.		Correct the system and user program so that there is a connection request from the remote node within the timeout time after the instruction is executed. Or, increase the timeout time.		Set up the system and user program so that there is a connection request from the remote node within the timeout time after the instruction is executed.	
	SkTTCPRcv or SkTUDPRcv instruction: Data was not received from the remote node during the user-set timeout time.		Correct the system and user program so that data is received from the remote node within the timeout time after the instruction is executed. Or, increase the timeout time.		Set up the system and user program so that data is received from the remote node within the timeout time after the instruction is executed.	
Attached information	<p>Attached Information 1: Error Location</p> <p>Attached Information 2: Error Location Details (Rung Number). For a program section, the rung number from the start of the section is given. For ST, the line number is given.</p> <p>Attached Information 3: Names of the Instruction and Instruction Instance Where the Error Occurred. If there is more than one possible instruction, information is given on all of them. Nothing is given if the instruction cannot be identified.</p> <p>Attached Information 4: Expansion Error Code (<i>ErrorIDEx</i>)</p>					
Precautions/Remarks	If a program is changed after an error occurs, the attached information that is displayed may not be correct.					

Event name	Socket Handle Out of Range			Event code	54012007 hex	
Meaning	The handle that is specified for the socket service instruction is not correct.					
Source	PLC Function Module		Source details	Instruction	Detection timing	At instruction execution
Error attributes	Level	Observation	Recovery	---	Log category	System
Effects	User program	Continues.	Operation	The relevant instruction will end according to specifications.		
System-defined variables	Variable		Data type		Name	
	None		---		---	
Cause and correction	Assumed cause		Correction		Prevention	
	The handle that is specified for the socket service instruction is not correct.		Correct the socket handle for the instruction to the handle that was obtained with one of the following instructions. <ul style="list-style-type: none"> • SktUDPCreate instruction • SktTCPConnect instruction • SktTCPAccept instruction 		Specify handles that are obtained with the following instructions. <ul style="list-style-type: none"> • SktUDPCreate instruction • SktTCPConnect instruction • SktTCPAccept instruction 	
Attached information	<p>Attached Information 1: Error Location</p> <p>Attached Information 2: Error Location Details (Rung Number). For a program section, the rung number from the start of the section is given. For ST, the line number is given.</p> <p>Attached Information 3: Names of the Instruction and Instruction Instance Where the Error Occurred. If there is more than one possible instruction, information is given on all of them. Nothing is given if the instruction cannot be identified.</p> <p>Attached Information 4: Expansion Error Code (<i>ErrorIDEx</i>)</p>					
Precautions/Remarks	If a program is changed after an error occurs, the attached information that is displayed may not be correct.					

Event name	Socket Communications Resource Overflow			Event code	54012008 hex	
Meaning	The maximum resources that you can use for socket service instructions at the same time was exceeded.					
Source	PLC Function Module		Source details	Instruction	Detection timing	At instruction execution
Error attributes	Level	Observation	Recovery	---	Log category	System
Effects	User program	Continues.	Operation	The relevant instruction will end according to specifications.		
System-defined variables	Variable		Data type		Name	
	None		---		---	
Cause and correction	Assumed cause		Correction		Prevention	
	More than 32 socket service instructions were executed at the same time.		Correct the user program so that no more than 32 socket service instructions are executed at the same time.		Write the user program so that no more than 32 socket service instructions are executed at the same time.	
	More than 30 socket handles were used at the same time. (For CPU Units with unit version 1.02 or earlier, more than 16 socket handles were used at the same time.)		Correct the user program so that no more than 30 socket handles are used at the same time (16 for CPU Units with unit version 1.02 or earlier).		Write the user program so that no more than 30 socket handles are used at the same time (16 for CPU Units with unit version 1.02 or earlier).	
Attached information	<p>Attached Information 1: Error Location</p> <p>Attached Information 2: Error Location Details (Rung Number). For a program section, the rung number from the start of the section is given. For ST, the line number is given.</p> <p>Attached Information 3: Names of the Instruction and Instruction Instance Where the Error Occurred. If there is more than one possible instruction, information is given on all of them. Nothing is given if the instruction cannot be identified.</p> <p>Attached Information 4: Expansion Error Code (<i>ErrorIDEx</i>)</p>					
Precautions/Remarks	If a program is changed after an error occurs, the attached information that is displayed may not be correct.					

Event name	No Execution Right		Event code	54012400 hex*		
Meaning	An instruction was executed to change the settings of the EtherNet/IP port when execution was not possible.					
Source	PLC Function Module		Source details	Instruction	Detection timing	At instruction execution
Error attributes	Level	Observation	Recovery	---	Log category	System
Effects	User program	Continues.	Operation	Not affected.		
System-defined variables	Variable		Data type		Name	
	None		---		---	
Cause and correction	Assumed cause		Correction		Prevention	
	An instruction to change the settings of the built-in EtherNet/IP port or a CJ-series EtherNet/IP Unit was executed when restart processing was in progress for the built-in EtherNet/IP port.		Execute the instruction to change the settings after restart processing or setting changes for the built-in EtherNet/IP port or CJ-series EtherNet/IP Unit are completed.		Execute the instruction to change the settings when restart processing or setting changes are not in progress for the built-in EtherNet/IP port or CJ-series EtherNet/IP Unit.	
	An instruction to change the settings of a CJ-series EtherNet/IP Unit was executed when restart processing was in progress for the Unit.					
	An instruction to change the settings of the built-in EtherNet/IP port or a CJ-series EtherNet/IP Unit was executed when changing settings was in progress for an instruction or CIP message for the built-in EtherNet/IP port.					
	An instruction to change the settings of a CJ-series EtherNet/IP Unit was executed when changing settings was in progress for an instruction or CIP message for the Unit.					
The unit number that was specified for the instruction is not for a built-in EtherNet/IP port or a CJ-series EtherNet/IP Unit.		Specify the unit number of a built-in EtherNet/IP port or CJ-series EtherNet/IP Unit for the instruction. If the Unit configuration is not correct, correct the Unit configuration.		Specify the unit number of a built-in EtherNet/IP port or CJ-series EtherNet/IP Unit for the instruction.		
Attached information	<p>Attached Information 1: Error Location</p> <p>Attached Information 2: Error Location Details (Rung Number). For a program section, the rung number from the start of the section is given. For ST, the line number is given.</p> <p>Attached Information 3: Names of the Instruction and Instruction Instance Where the Error Occurred. If there is more than one possible instruction, information is given on all of them. Nothing is given if the instruction cannot be identified.</p> <p>Attached Information 4: Expansion Error Code (<i>ErrorIDEx</i>)</p>					
Precautions/Remarks	If a program is changed after an error occurs, the attached information that is displayed may not be correct.					

* Error code 16#2400 occurs for unit version 1.02 or later of the CPU Unit.

Event name	Settings Update Failed			Event code	54012401 hex*	
Meaning	It was not possible to update the settings of the CJ-series EtherNet/IP Unit that were changed.					
Source	PLC Function Module		Source details	Instruction	Detection timing	At instruction execution
Error attributes	Level	Observation	Recovery	---	Log category	System
Effects	User program	Continues.	Operation	Not affected.		
System-defined variables	Variable		Data type		Name	
	None		---		---	
Cause and correction	Assumed cause		Correction		Prevention	
	Restart processing for a Unit or built-in EtherNet/IP port was started during execution of an instruction to change the settings of a CJ-series EtherNet/IP Unit.		Execute the instruction again to change the settings after restart processing for the built-in EtherNet/IP port or CJ-series EtherNet/IP Unit is completed.		Do not start restart processing for a Unit or built-in EtherNet/IP port during execution of an instruction to change the settings of a CJ-series EtherNet/IP Unit.	
Attached information	<p>Attached Information 1: Error Location</p> <p>Attached Information 2: Error Location Details (Rung Number). For a program section, the rung number from the start of the section is given. For ST, the line number is given.</p> <p>Attached Information 3: Names of the Instruction and Instruction Instance Where the Error Occurred. If there is more than one possible instruction, information is given on all of them. Nothing is given if the instruction cannot be identified.</p> <p>Attached Information 4: Expansion Error Code (<i>ErrorIDEx</i>)</p>					
Precautions/Remarks	If a program is changed after an error occurs, the attached information that is displayed may not be correct.					

* Error code 16#2401 occurs for unit version 1.02 or later of the CPU Unit.

Event name	Too Many Simultaneous Instruction Executions			Event code	54012402 hex*	
Meaning	Too many instructions to change the communications setup of the Controller were executed at the same time.					
Source	PLC Function Module		Source details	Instruction	Detection timing	At instruction execution
Error attributes	Level	Observation	Recovery	---	Log category	System
Effects	User program	Continues.	Operation	Not affected.		
System-defined variables	Variable		Data type		Name	
	None		---		---	
Cause and correction	Assumed cause		Correction		Prevention	
	Two or more instructions to change the communications setup of the Controller were executed at the same time.		Correct the user program so that only one instruction to change the communications setup of the Controller is executed at the same time.		Write the user program so that only one instruction to change the communications setup of the Controller is executed at the same time.	
Attached information	<p>Attached Information 1: Error Location</p> <p>Attached Information 2: Error Location Details (Rung Number). For a program section, the rung number from the start of the section is given. For ST, the line number is given.</p> <p>Attached Information 3: Names of the Instruction and Instruction Instance Where the Error Occurred. If there is more than one possible instruction, information is given on all of them. Nothing is given if the instruction cannot be identified.</p> <p>Attached Information 4: Expansion Error Code (<i>ErrorIDEx</i>)</p>					
Precautions/Remarks	If a program is changed after an error occurs, the attached information that is displayed may not be correct.					

* Error code 16#2402 occurs for unit version 1.02 or later of the CPU Unit.

Event name	FTP Client Execution Limit Exceeded			Event code	54012403 hex*	
Meaning	Too many FTP client communications instructions were executed at the same time.					
Source	PLC Function Module		Source details	Instruction	Detection timing	At instruction execution
Error attributes	Level	Observation	Recovery	---	Log category	System
Effects	User program	Continues.	Operation	Not affected.		
System-defined variables	Variable		Data type		Name	
	None		---		---	
Cause and correction	Assumed cause		Correction		Prevention	
	Four or more FTP client communications instructions were executed at the same time.		Correct the user program so that no more than three FTP client communications instructions are executed at the same time.		Write the user program so that no more than three FTP client communications instructions are executed at the same time.	
Attached information	<p>Attached Information 1: Error Location</p> <p>Attached Information 2: Error Location Details (Rung Number). For a program section, the rung number from the start of the section is given. For ST, the line number is given.</p> <p>Attached Information 3: Names of the Instruction and Instruction Instance Where the Error Occurred. If there is more than one possible instruction, information is given on all of them. Nothing is given if the instruction cannot be identified.</p> <p>Attached Information 4: Expansion Error Code (<i>ErrorIDEx</i>)</p>					
Precautions/Remarks	If a program is changed after an error occurs, the attached information that is displayed may not be correct.					

* Error code 16#2403 occurs for unit version 1.08 or later of the CPU Unit.

Event name	File Number Limit Exceeded			Event code	54012404 hex*	
Meaning	The number of files specified with a wildcard for an FTP client communications instruction exceeded 1,000.					
Source	PLC Function Module		Source details	Instruction	Detection timing	At instruction execution
Error attributes	Level	Observation	Recovery	---	Log category	System
Effects	User program	Continues.	Operation	Not affected.		
System-defined variables	Variable		Data type		Name	
	None		---		---	
Cause and correction	Assumed cause		Correction		Prevention	
	The number of files specified with a file name that contained a wildcard for an FTP client communications instruction exceeded 1,000.		Correct the program so that the number of files specified with a wildcard for an FTP client communications instruction does not exceed 1,000.		Write the program so that the number of files specified with a wildcard for an FTP client communications instruction does not exceed 1,000.	
Attached information	<p>Attached Information 1: Error Location</p> <p>Attached Information 2: Error Location Details (Rung Number). For a program section, the rung number from the start of the section is given. For ST, the line number is given.</p> <p>Attached Information 3: Names of the Instruction and Instruction Instance Where the Error Occurred. If there is more than one possible instruction, information is given on all of them. Nothing is given if the instruction cannot be identified.</p> <p>Attached Information 4: Expansion Error Code (<i>ErrorIDEx</i>)</p>					
Precautions/Remarks	If a program is changed after an error occurs, the attached information that is displayed may not be correct.					

* Error code 16#2404 occurs for unit version 1.08 or later of the CPU Unit.

Event name	Directory Does Not Exist (FTP)			Event code	54012405 hex*	
Meaning	The directory specified for an FTP client communications instruction does not exist in the Controller or an incorrect path was specified.					
Source	PLC Function Module		Source details	Instruction	Detection timing	At instruction execution
Error attributes	Level	Observation	Recovery	---	Log category	System
Effects	User program	Continues.	Operation	Not affected.		
System-defined variables	Variable		Data type		Name	
	None		---		---	
Cause and correction	Assumed cause		Correction		Prevention	
	The directory specified for an FTP client communications instruction does not exist in the Controller or an incorrect path was specified.		Correct the program so that the directory specified for the FTP client communications instruction exists in the SD Memory Card.		Write the program so that the directory specified for the FTP client communications instruction exists in the SD Memory Card.	
Attached information	<p>Attached Information 1: Error Location</p> <p>Attached Information 2: Error Location Details (Rung Number). For a program section, the rung number from the start of the section is given. For ST, the line number is given.</p> <p>Attached Information 3: Names of the Instruction and Instruction Instance Where the Error Occurred. If there is more than one possible instruction, information is given on all of them. Nothing is given if the instruction cannot be identified.</p> <p>Attached Information 4: Expansion Error Code (<i>ErrorIDEx</i>)</p>					
Precautions/Remarks	If a program is changed after an error occurs, the attached information that is displayed may not be correct.					

* Error code 16#2405 occurs for unit version 1.08 or later of the CPU Unit.

Event name	FTP Server Connection Error			Event code	54012406 hex*	
Meaning	The destination FTP server that was specified for an FTP client communications instruction does not exist on the network or the specified FTP server is not operating.					
Source	PLC Function Module		Source details	Instruction	Detection timing	At instruction execution
Error attributes	Level	Observation	Recovery	---	Log category	System
Effects	User program	Continues.	Operation	Not affected.		
System-defined variables	Variable		Data type		Name	
	None		---		---	
Cause and correction	Assumed cause		Correction		Prevention	
	The destination FTP server that was specified for an FTP client communications instruction does not exist on the network.		Correct the program so that the FTP server specified for the FTP client communications instruction exists on the network.		Write the program so that the FTP server specified for the FTP client communications instruction exists on the network.	
	The destination FTP server that was specified for an FTP client communications instruction is not operating.		Start the FTP server that was specified as the destination FTP server and then execute the instruction again.		Confirm that the FTP server that is specified as the destination FTP server is operating before you execute the instruction.	
Attached information	<p>Attached Information 1: Error Location</p> <p>Attached Information 2: Error Location Details (Rung Number). For a program section, the rung number from the start of the section is given. For ST, the line number is given.</p> <p>Attached Information 3: Names of the Instruction and Instruction Instance Where the Error Occurred. If there is more than one possible instruction, information is given on all of them. Nothing is given if the instruction cannot be identified.</p> <p>Attached Information 4: Expansion Error Code (<i>ErrorIDEx</i>)</p>					
Precautions/Remarks	If a program is changed after an error occurs, the attached information that is displayed may not be correct.					

* Error code 16#2406 occurs for unit version 1.08 or later of the CPU Unit.

Event name	Destination FTP Server Execution Failure		Event code	54012407 hex*		
Meaning	The destination FTP server for an FTP client communications instruction returned an error.					
Source	PLC Function Module		Source details	Instruction	Detection timing	At instruction execution
Error attributes	Level	Observation	Recovery	---	Log category	System
Effects	User program	Continues.	Operation	Not affected.		
System-defined variables	Variable		Data type		Name	
	None		---		---	
Cause and correction	Assumed cause		Correction		Prevention	
	The destination FTP server for the FTP client communications instruction failed to execute the requested processing.		Check the response code from the destination FTP server in the value of the <i>ErrorIDEx</i> output variable from the instruction and refer to the description in this manual for the expansion error code (<i>ErrorIDEx</i>) with the same value for the instruction.		Read the description of <i>ErrorIDEx</i> in advance for the instruction and program correctly.	
Attached information	Attached Information 1: Error Location Attached Information 2: Error Location Details (Rung Number). For a program section, the rung number from the start of the section is given. For ST, the line number is given. Attached Information 3: Names of the Instruction and Instruction Instance Where the Error Occurred. If there is more than one possible instruction, information is given on all of them. Nothing is given if the instruction cannot be identified. Attached Information 4: Expansion Error Code (<i>ErrorIDEx</i>)					
Precautions/Remarks	If a program is changed after an error occurs, the attached information that is displayed may not be correct.					

* Error code 16#2407 occurs for unit version 1.08 or later of the CPU Unit.

Event name	SD Memory Card Access Failed for FTP		Event code	54012408 hex*		
Meaning	SD Memory Card access from the FTP client failed.					
Source	PLC Function Module		Source details	Instruction	Detection timing	At instruction execution
Error attributes	Level	Observation	Recovery	---	Log category	System
Effects	User program	Continues.	Operation	Not affected.		
System-defined variables	Variable		Data type		Name	
	None		---		---	
Cause and correction	Assumed cause		Correction		Prevention	
	An SD Memory Card is not inserted.		Insert an SD Memory Card and then execute the instruction again.		Insert an SD Memory Card.	
	The SD Memory Card was removed during execution of the FTP client communications instruction.		Insert an SD Memory Card and then execute the instruction again.		Do not remove the SD Memory Card during execution of the FTP client communications instruction.	
	The capacity of the SD Memory Card is insufficient.		Replace the SD Memory Card for one with sufficient available capacity.		Use an SD Memory Card with sufficient available capacity.	
Attached information	The SD Memory Card is write protected.		Remove write protection from the SD Memory Card.		Make sure that the SD Memory Card is not write protected.	
	Attached Information 1: Error Location Attached Information 2: Error Location Details (Rung Number). For a program section, the rung number from the start of the section is given. For ST, the line number is given. Attached Information 3: Names of the Instruction and Instruction Instance Where the Error Occurred. If there is more than one possible instruction, information is given on all of them. Nothing is given if the instruction cannot be identified. Attached Information 4: Expansion Error Code (<i>ErrorIDEx</i>)					
Precautions/Remarks	If a program is changed after an error occurs, the attached information that is displayed may not be correct.					

* Error code 16#2408 occurs for unit version 1.08 or later of the CPU Unit.

Event name	Specified File Does Not Exist			Event code	54012409 hex*	
Meaning	A file specified for an FTP client communications instruction does not exist.					
Source	PLC Function Module		Source details	Instruction	Detection timing	At instruction execution
Error attributes	Level	Observation	Recovery	---	Log category	System
Effects	User program	Continues.	Operation	Not affected.		
System-defined variables	Variable		Data type		Name	
	None		---		---	
Cause and correction	Assumed cause		Correction		Prevention	
	A file specified for an FTP client communications instruction does not exist.		Correct the program so that the file specified for the FTP client communications instruction exists.		Write the program so that the file specified for the FTP client communications instruction exists.	
Attached information	<p>Attached Information 1: Error Location</p> <p>Attached Information 2: Error Location Details (Rung Number). For a program section, the rung number from the start of the section is given. For ST, the line number is given.</p> <p>Attached Information 3: Names of the Instruction and Instruction Instance Where the Error Occurred. If there is more than one possible instruction, information is given on all of them. Nothing is given if the instruction cannot be identified.</p> <p>Attached Information 4: Expansion Error Code (<i>ErrorIDEx</i>)</p>					
Precautions/Remarks	If a program is changed after an error occurs, the attached information that is displayed may not be correct.					

* Error code 16#2409 occurs for unit version 1.08 or later of the CPU Unit.

Event name	Specified File Is Write Protected			Event code	5401240A hex*	
Meaning	The data was not transferred because the FTP client communications instruction was set to not overwrite files with the same name.					
Source	PLC Function Module		Source details	Instruction	Detection timing	At instruction execution
Error attributes	Level	Observation	Recovery	---	Log category	System
Effects	User program	Continues.	Operation	Not affected.		
System-defined variables	Variable		Data type		Name	
	None		---		---	
Cause and correction	Assumed cause		Correction		Prevention	
	The data was not transferred because the FTP client communications instruction was set to not overwrite files with the same name and a file with the specified file name already existed at the destination.		Set the FTP client communications instruction to overwrite files with the same name and then execute the instruction again. Or, change the file name at the source or destination and then execute the instruction again.		Set the FTP client communications instruction to overwrite files with the same name. Or, make sure different file names are used at the source and destination.	
Attached information	<p>Attached Information 1: Error Location</p> <p>Attached Information 2: Error Location Details (Rung Number). For a program section, the rung number from the start of the section is given. For ST, the line number is given.</p> <p>Attached Information 3: Names of the Instruction and Instruction Instance Where the Error Occurred. If there is more than one possible instruction, information is given on all of them. Nothing is given if the instruction cannot be identified.</p> <p>Attached Information 4: Expansion Error Code (<i>ErrorIDEx</i>)</p>					
Precautions/Remarks	If a program is changed after an error occurs, the attached information that is displayed may not be correct.					

* Error code 16#240A occurs for unit version 1.08 or later of the CPU Unit.

Event name	Failed To Delete Specified File		Event code	5401240B hex*	
Meaning	A file was not deleted after it was transferred with an FTP client communications instruction.				
Source	PLC Function Module	Source details	Instruction	Detection timing	At instruction execution
Error attributes	Level	Observation	Recovery	---	Log category System
Effects	User program	Continues.	Operation	Not affected.	
System-defined variables	Variable	Data type		Name	
	None	---		---	
Cause and correction	Assumed cause		Correction		Prevention
	The FTP client communications instruction was set to delete files after they are transferred, but it was not possible to delete the specified file because it had a read-only attribute.		Set the FTP client communications instruction to not delete files after they are transferred and then execute the instruction again. Or, change the attribute of the source file to enable writing it and then execute the instruction again.		Set the FTP client communications instruction to not delete files after they are transferred. Or do not set the attribute of source files to read-only.
	It was not possible to delete the file specified for the FTP client communications instruction because it was in use by another application.		Execute the FTP client communications instruction when the specified file is not in use by another application.		Do not use the file specified for the FTP client communications instruction in another application.
Attached information	<p>Attached Information 1: Error Location</p> <p>Attached Information 2: Error Location Details (Rung Number). For a program section, the rung number from the start of the section is given. For ST, the line number is given.</p> <p>Attached Information 3: Names of the Instruction and Instruction Instance Where the Error Occurred. If there is more than one possible instruction, information is given on all of them. Nothing is given if the instruction cannot be identified.</p> <p>Attached Information 4: Expansion Error Code (<i>ErrorIDEx</i>)</p>				
Precautions/Remarks	If a program is changed after an error occurs, the attached information that is displayed may not be correct.				

* Error code 16#240B occurs for unit version 1.08 or later of the CPU Unit.

Event name	Specified File Access Failed		Event code	5401240C hex*		
Meaning	An FTP transfer for an FTP client communications instruction failed because file access failed.					
Source	PLC Function Module		Source details	Instruction	Detection timing	At instruction execution
Error attributes	Level	Observation	Recovery	---	Log category	System
Effects	User program	Continues.	Operation	Not affected.		
System-defined variables	Variable		Data type		Name	
	None		---		---	
Cause and correction	Assumed cause		Correction		Prevention	
	The file specified for the FTP client communications instruction was in use by another application.		Execute the FTP client communications instruction when the specified file is not in use by another application.		Do not use the file specified for the FTP client communications instruction in another application.	
	The file or directory specified for the FTP client communications instruction to write is write protected.		Remove write protection from the file specified for the FTP client communications instruction to write. Or, change the filename of the file to write.		Do not write-protect the file specified for an FTP client communications instruction to write.	
Attached information	<p>Attached Information 1: Error Location</p> <p>Attached Information 2: Error Location Details (Rung Number). For a program section, the rung number from the start of the section is given. For ST, the line number is given.</p> <p>Attached Information 3: Names of the Instruction and Instruction Instance Where the Error Occurred. If there is more than one possible instruction, information is given on all of them. Nothing is given if the instruction cannot be identified.</p> <p>Attached Information 4: Expansion Error Code (<i>ErrorIDEx</i>)</p>					
Precautions/Remarks	If a program is changed after an error occurs, the attached information that is displayed may not be correct.					

* Error code 16#240C occurs for unit version 1.08 or later of the CPU Unit.

Event name	IP Address Setting Invalid		Event code	5401240D hex*		
Meaning	Instruction execution was not possible because there is an error between the IP address setting of the port specified in the instruction and the other port settings.					
Source	PLC Function Module		Source details	Instruction	Detection timing	At instruction execution
Error attributes	Level	Observation	Recovery	---	Log category	System
Effects	User program	Continues.	Operation	Operation is not affected.		
System-defined variables	Variable		Data type		Name	
	None		---		---	
Cause and correction	Assumed cause		Correction		Prevention	
	The network address of the port specified in the instruction is the same as the network address of another port.		Correct the instruction so that it specifies a network address that is not the same as the network address of another port. Or, change the network address of the other port in advance.		When using instructions to change IP addresses, specify network addresses that are not the same as the network addresses of other ports.	
	Both the port specified in the instruction and the other ports are set as unused ports.		Correct the setting of the port specified in the instruction to anything but an unused port. Or, change the unused port setting of another port in advance.		When you use an instruction to change the IP address, make sure that the port specified in the instruction and the other ports are not all set to unused ports.	
Attached information	<p>Attached Information 1: Error Location</p> <p>Attached Information 2: Error Location Details (Rung Number). For a program section, the rung number from the start of the section is given. For ST, the line number is given.</p> <p>Attached Information 3: Names of the Instruction and Instruction Instance Where the Error Occurred. If there is more than one possible instruction, information is given on all of them. Nothing is given if the instruction cannot be identified.</p> <p>Attached Information 4: Expansion Error Code (<i>ErrorIDEx</i>)</p>					
Precautions/Remarks	If a program is changed after an error occurs, the attached information that is displayed may not be correct.					

* Error code 16#240D occurs for unit version 2.00 or later of the CPU Unit.

Event name	NX Message Error		Event code	54012C00 hex*		
Meaning	An error response code was returned for an NX message.					
Source	PLC Function Module		Source details	Instruction	Detection timing	At instruction execution
Error attributes	Level	Observation	Recovery	---	Log category	System
Effects	User program	Continues.	Operation	The relevant instruction will end according to specifications.		
System-defined variables	Variable		Data type		Name	
	None		---		---	
Cause and correction	Assumed cause		Correction		Prevention	
	Depends on the nature of the error.		Check the value of the <i>ErrorIDEx</i> output variable from the instruction and refer to the description in this manual of the NX message error code.		Depends on the nature of the error. Refer to the description in this manual of the NX message error code.	
Attached information	<p>Attached Information 1: Error Location</p> <p>Attached Information 2: Error Location Details (Rung Number). For a program section, the rung number from the start of the section is given. For ST, the line number is given.</p> <p>Attached Information 3: Names of the Instruction and Instruction Instance Where the Error Occurred. If there is more than one possible instruction, information is given on all of them. Nothing is given if the instruction cannot be identified.</p> <p>Attached Information 4: Expansion Error Code (<i>ErrorIDEx</i>)</p>					
Precautions/Remarks	If a program is changed after an error occurs, the attached information that is displayed may not be correct.					

* Error code 16#2C00 occurs for unit version 1.05 or later of the CPU Unit.

Event name	NX Message Resource Overflow		Event code	54012C01 hex*		
Meaning	The maximum resources that you can use for NX message instructions at the same time was exceeded.					
Source	PLC Function Module		Source details	Instruction	Detection timing	At instruction execution
Error attributes	Level	Observation	Recovery	---	Log category	System
Effects	User program	Continues.	Operation	The relevant instruction will end according to specifications.		
System-defined variables	Variable		Data type		Name	
	None		---		---	
Cause and correction	Assumed cause		Correction		Prevention	
	More than 32 NX message instructions were executed at the same time.		Correct the user program so that no more than 32 NX message instructions are executed at the same time.		Write the user program so that no more than 32 NX message instructions are executed at the same time.	
Attached information	<p>Attached Information 1: Error Location</p> <p>Attached Information 2: Error Location Details (Rung Number). For a program section, the rung number from the start of the section is given. For ST, the line number is given.</p> <p>Attached Information 3: Names of the Instruction and Instruction Instance Where the Error Occurred. If there is more than one possible instruction, information is given on all of them. Nothing is given if the instruction cannot be identified.</p> <p>Attached Information 4: Expansion Error Code (<i>ErrorIDEx</i>)</p>					
Precautions/Remarks	If a program is changed after an error occurs, the attached information that is displayed may not be correct.					

* Error code 16#2C01 occurs for unit version 1.05 or later of the CPU Unit.

Event name	NX Message Timeout		Event code	54012C02 hex*		
Meaning	A timeout occurred during execution of an NX message.					
Source	PLC Function Module		Source details	Instruction	Detection timing	At instruction execution
Error attributes	Level	Observation	Recovery	---	Log category	System
Effects	User program	Continues.	Operation	The relevant instruction will end according to specifications.		
System-defined variables	Variable		Data type		Name	
	None		---		---	
Cause and correction	Assumed cause		Correction		Prevention	
	The specified NX Unit does not exist.		Make corrections so that the Unit specification and the remote Unit configuration agree.		Make sure that Unit specifications and the remote Unit configuration agree.	
	The NX message was closed because it timed out.		Increase the response timeout time that is specified for the <i>TimeOut</i> input variable in the instruction.		Execute instructions after setting suitable response timeout times for the <i>TimeOut</i> input variable.	
	Power to the remote Unit is OFF.		Check the status of the remote Unit and start it normally.		Check the status of the remote Unit and start it normally.	
	Communications are stopped at the remote Unit.					
	The communications cable connector is disconnected.		Reconnect the connector and make sure it is mated correctly.		Connect the connector securely.	
	The communications cable is broken.		Replace the communications cable.		None	
Noise		Implement noise countermeasures if there is excessive noise.		Implement noise countermeasures if there is excessive noise.		
Attached information	<p>Attached Information 1: Error Location</p> <p>Attached Information 2: Error Location Details (Rung Number). For a program section, the rung number from the start of the section is given. For ST, the line number is given.</p> <p>Attached Information 3: Names of the Instruction and Instruction Instance Where the Error Occurred. If there is more than one possible instruction, information is given on all of them. Nothing is given if the instruction cannot be identified.</p> <p>Attached Information 4: Expansion Error Code (<i>ErrorIDEx</i>)</p>					
Precautions/Remarks	If a program is changed after an error occurs, the attached information that is displayed may not be correct.					

* Error code 16#2C02 occurs for unit version 1.05 or later of the CPU Unit.

Event name	Incorrect NX Message Length			Event code	54012C03 hex*	
Meaning	The length of the NX message is not correct.					
Source	PLC Function Module		Source details	Instruction	Detection timing	At instruction execution
Error attributes	Level	Observation	Recovery	---	Log category	System
Effects	User program	Continues.	Operation	The relevant instruction will end according to specifications.		
System-defined variables	Variable		Data type		Name	
	None		---		---	
Cause and correction	Assumed cause		Correction		Prevention	
	The size that is specified for WriteDat or Path is too long.		Correct the program so that the size that is specified for WriteDat or Path is within the restriction.		Write the program so that the size that is specified for WriteDat or Path is within the restriction.	
Attached information	<p>Attached Information 1: Error Location</p> <p>Attached Information 2: Error Location Details (Rung Number). For a program section, the rung number from the start of the section is given. For ST, the line number is given.</p> <p>Attached Information 3: Names of the Instruction and Instruction Instance Where the Error Occurred. If there is more than one possible instruction, information is given on all of them. Nothing is given if the instruction cannot be identified.</p> <p>Attached Information 4: Expansion Error Code (<i>ErrorIDEx</i>)</p>					
Precautions/Remarks	If a program is changed after an error occurs, the attached information that is displayed may not be correct.					

* Error code 16#2C03 occurs for unit version 1.05 or later of the CPU Unit.

Event name	NX Message EtherCAT Network Error			Event code	54012C05 hex*	
Meaning	An error occurred in EtherCAT communications on the NX message path.					
Source	PLC Function Module		Source details	Instruction	Detection timing	At instruction execution
Error attributes	Level	Observation	Recovery	---	Log category	System
Effects	User program	Continues.	Operation	The relevant instruction will end according to specifications.		
System-defined variables	Variable		Data type		Name	
	None		---		---	
Cause and correction	Assumed cause		Correction		Prevention	
	An error occurred in EtherCAT communications on the NX message path.		Check for errors in EtherCAT communications and execute the instruction after clearing any errors.		Depends on the nature of the error.	
Attached information	<p>Attached Information 1: Error Location</p> <p>Attached Information 2: Error Location Details (Rung Number). For a program section, the rung number from the start of the section is given. For ST, the line number is given.</p> <p>Attached Information 3: Names of the Instruction and Instruction Instance Where the Error Occurred. If there is more than one possible instruction, information is given on all of them. Nothing is given if the instruction cannot be identified.</p> <p>Attached Information 4: Expansion Error Code (<i>ErrorIDEx</i>)</p>					
Precautions/Remarks	If a program is changed after an error occurs, the attached information that is displayed may not be correct.					

* Error code 16#2C05 occurs for unit version 1.05 or later of the CPU Unit.

Event name	External Restart Already Executed for Specified NX Units		Event code	54012C06 hex*		
Meaning	A restart was already in execution from the Sysmac Studio when the instruction was executed.					
Source	PLC Function Module		Source details	Instruction	Detection timing	At instruction execution
Error attributes	Level	Observation	Recovery	---	Log category	System
Effects	User program	Continues.	Operation	The relevant instruction will end according to specifications.		
System-defined variables	Variable		Data type		Name	
	None		---		---	
Cause and correction	Assumed cause		Correction		Prevention	
	A restart was already in execution from the Sysmac Studio when the instruction was executed.		Restarting with an instruction is not necessary if a restart was already executed from the Sysmac Studio.		Do not execute restarts from the Sysmac Studio during operation.	
Attached information	<p>Attached Information 1: Error Location</p> <p>Attached Information 2: Error Location Details (Rung Number). For a program section, the rung number from the start of the section is given. For ST, the line number is given.</p> <p>Attached Information 3: Names of the Instruction and Instruction Instance Where the Error Occurred. If there is more than one possible instruction, information is given on all of them. Nothing is given if the instruction cannot be identified.</p> <p>Attached Information 4: Expansion Error Code (<i>ErrorIDEx</i>)</p>					
Precautions/Remarks	If a program is changed after an error occurs, the attached information that is displayed may not be correct.					

* Error code 16#2C06 occurs for unit version 1.05 or later of the CPU Unit.

Event name	Unapplicable Unit Specified for Instruction		Event code	54012C07 hex*		
Meaning	A slave that cannot be specified for the instruction was connected at the slave node address of the specified Unit.					
Source	PLC Function Module		Source details	Instruction	Detection timing	At instruction execution
Error attributes	Level	Observation	Recovery	---	Log category	System
Effects	User program	Continues.	Operation	The relevant instruction will end according to specifications.		
System-defined variables	Variable		Data type		Name	
	None		---		---	
Cause and correction	Assumed cause		Correction		Prevention	
	A slave that cannot be specified for the instruction was connected to the slave node address of the specified Unit.		Connect the applicable Unit for the instruction that is specified in the network configuration information.		Do not connect a slave that cannot be specified for the instruction to the slave node address of the specified Unit.	
Attached information	<p>Attached Information 1: Error Location</p> <p>Attached Information 2: Error Location Details (Rung Number). For a program section, the rung number from the start of the section is given. For ST, the line number is given.</p> <p>Attached Information 3: Names of the Instruction and Instruction Instance Where the Error Occurred. If there is more than one possible instruction, information is given on all of them. Nothing is given if the instruction cannot be identified.</p> <p>Attached Information 4: Expansion Error Code (<i>ErrorIDEx</i>)</p>					
Precautions/Remarks	If a program is changed after an error occurs, the attached information that is displayed may not be correct.					

* Error code 16#2C07 occurs for unit version 1.05 or later of the CPU Unit.

Event name	Invalid Total Power ON Time Record		Event code	54012C08 hex*		
Meaning	The total power ON time could not be read.					
Source	PLC Function Module		Source details	Instruction	Detection timing	At instruction execution
Error attributes	Level	Observation	Recovery	---	Log category	System
Effects	User program	Continues.	Operation	The relevant instruction will end according to specifications.		
System-defined variables	Variable		Data type		Name	
	None		---		---	
Cause and correction	Assumed cause		Correction		Prevention	
	Non-volatile memory failure		Replace the Unit for which the total power ON time could not be read.		None	
Attached information	<p>Attached Information 1: Error Location</p> <p>Attached Information 2: Error Location Details (Rung Number). For a program section, the rung number from the start of the section is given. For ST, the line number is given.</p> <p>Attached Information 3: Names of the Instruction and Instruction Instance Where the Error Occurred. If there is more than one possible instruction, information is given on all of them. Nothing is given if the instruction cannot be identified.</p> <p>Attached Information 4: Expansion Error Code (<i>ErrorIDEx</i>)</p>					
Precautions/Remarks	If a program is changed after an error occurs, the attached information that is displayed may not be correct.					

* Error code 16#2C08 occurs for unit version 2.00 or later of the CPU Unit.

Event name	Process Data Object Setting Missing		Event code	54013461 hex		
Meaning	The PDO mapping is not correct.					
Source	PLC Function Module		Source details	Instruction	Detection timing	At instruction execution
Error attributes	Level	Observation	Recovery	---	Log category	System
Effects	User program	Continues.	Operation	The relevant instruction will end according to specifications.		
System-defined variables	Variable		Data type		Name	
	_MC_AX[*].MFaultLvl.Active		BOOL		Axis Minor Fault Occurrence	
Cause and correction	Assumed cause		Correction		Prevention	
	The PDOs that are required for the motion control instruction are not mapped.		Map the PDOs that are required for the instruction. Refer to the <i>Function</i> section of the relevant instruction for the required PDOs.		Map the PDOs that are required for the instructions that are used. Refer to the <i>NJ/NX-series CPU Unit Motion Control User's Manual</i> (Cat. No. W507) for the PDOs (Servo Drive settings) that you must map for each instruction.	
	The relevant instruction was executed for a device that does not have an object that supports the instruction.		Some devices do not support the relevant instruction. Refer to the manual for the target device, check to see if the relevant instruction is supported, and correct the program so that unsupported instructions are not executed.		Refer to the manual for the target device and write the program so that unsupported instructions are not executed.	
	A motion control instruction that specifies phase Z (_mcEncoderMark) as the trigger conditions was executed for an axis that is mapped to an OMRON GX-EC02□□ EtherCAT Encoder slave.		Use an external input (_mcEXT) as the trigger conditions for an axis that is mapped to an OMRON GX-EC02□□ EtherCAT Encoder slave.		Use an external input (_mcEXT) as the trigger conditions for an axis that is mapped to an OMRON GX-EC02□□ EtherCAT Encoder slave.	
Attached information	<p>Attached Information 1: Error Location</p> <p>Attached Information 2: Error Location Details (Rung Number). For a program section, the rung number from the start of the section is given. For ST, the line number is given.</p> <p>Attached Information 3: Names of the Instruction and Instruction Instance Where the Error Occurred. If there is more than one possible instruction, information is given on all of them. Nothing is given if the instruction cannot be identified.</p> <p>Attached Information 4: Expansion Error Code (<i>ErrorIDEx</i>)</p>					
Precautions/Remarks	If a program is changed after an error occurs, the attached information that is displayed may not be correct.					

Event name	Device Error Received			Event code	54014800 hex*	
Meaning	An error response from the device was received.					
Source	PLC Function Module		Source details	Instruction	Detection timing	At instruction execution
Error attributes	Level	Observation	Recovery	---	Log category	System
Effects	User program	Continues.	Operation	The relevant instruction will end according to specifications.		
System-defined variables	Variable		Data type		Name	
	None		---		---	
Cause and correction	Assumed cause		Correction		Prevention	
	An error response from the device was received.		The error code that is returned by the device is output to the <i>ErrorType</i> output variable of the instruction. Check the error information in the manual for the target device and correct the problem.		Check the error cause in the manual for the device before you write the user program and execute the instruction.	
Attached information	Attached Information 1: Error Location Attached Information 2: Error Location Details (Rung Number). For a program section, the rung number from the start of the section is given. For ST, the line number is given. Attached Information 3: Names of the Instruction and Instruction Instance Where the Error Occurred. If there is more than one possible instruction, information is given on all of them. Nothing is given if the instruction cannot be identified. Attached Information 4: Expansion Error Code (<i>ErrorType</i>)					
Precautions/Remarks	If a program is changed after an error occurs, the attached information that is displayed may not be correct.					

* Error code 16#4800 occurs for unit version 1.12 or later of the CPU Unit.

Event name	Specified Unit Does Not Exist			Event code	54014801 hex*	
Meaning	The specified Unit does not exist.					
Source	PLC Function Module		Source details	Instruction	Detection timing	At instruction execution
Error attributes	Level	Observation	Recovery	---	Log category	System
Effects	User program	Continues.	Operation	The relevant instruction will end according to specifications.		
System-defined variables	Variable		Data type		Name	
	None		---		---	
Cause and correction	Assumed cause		Correction		Prevention	
	The IO-Link master is not connected to or mounted on the specified position.		Connect or mount the IO-Link master to or on the specified position. Or, specify the position where the IO-Link master is connected or mounted.		Connect or mount the IO-Link master to or on the specified position. Or, specify the position where the IO-Link master is connected or mounted.	
Attached information	Attached Information 1: Error Location Attached Information 2: Error Location Details (Rung Number). For a program section, the rung number from the start of the section is given. For ST, the line number is given. Attached Information 3: Names of the Instruction and Instruction Instance Where the Error Occurred. If there is more than one possible instruction, information is given on all of them. Nothing is given if the instruction cannot be identified. Attached Information 4: Expansion Error Code (<i>ErrorType</i>)					
Precautions/Remarks	If a program is changed after an error occurs, the attached information that is displayed may not be correct.					

* Error code 16#4801 occurs for unit version 1.12 or later of the CPU Unit.

Event name	Message Processing Limit Exceeded		Event code	54014802 hex*		
Meaning	An instruction cannot be executed because the IO-Link master is processing the message from another application.					
Source	PLC Function Module		Source details	Instruction	Detection timing	At instruction execution
Error attributes	Level	Observation	Recovery	---	Log category	System
Effects	User program	Continues.	Operation	The relevant instruction will end according to specifications.		
System-defined variables	Variable		Data type		Name	
	None		---		---	
Cause and correction	Assumed cause		Correction		Prevention	
	An instruction cannot be executed because the IO-Link master is processing the message from another application (an instruction execution or a tool connection).		Execute the instruction again.		Perform processing for exclusive control of messages in applications (an instruction execution or a tool connection). Or, increase the number of retries.	
Attached information	<p>Attached Information 1: Error Location</p> <p>Attached Information 2: Error Location Details (Rung Number). For a program section, the rung number from the start of the section is given. For ST, the line number is given.</p> <p>Attached Information 3: Names of the Instruction and Instruction Instance Where the Error Occurred. If there is more than one possible instruction, information is given on all of them. Nothing is given if the instruction cannot be identified.</p> <p>Attached Information 4: Expansion Error Code (<i>ErrorType</i>)</p>					
Precautions/Remarks	If a program is changed after an error occurs, the attached information that is displayed may not be correct.					

* Error code 16#4802 occurs for unit version 1.12 or later of the CPU Unit.

Event name	Specified Unit Status Error		Event code	54014803 hex*		
Meaning	The specified Unit is not in a condition to receive messages.					
Source	PLC Function Module		Source details	Instruction	Detection timing	At instruction execution
Error attributes	Level	Observation	Recovery	---	Log category	System
Effects	User program	Continues.	Operation	The relevant instruction will end according to specifications.		
System-defined variables	Variable		Data type		Name	
	None		---		---	
Cause and correction	Assumed cause		Correction		Prevention	
	The specified Unit is not in a condition to receive messages.		Execute the instruction again.		When this error occurs, execute the instruction again.	
Attached information	<p>Attached Information 1: Error Location</p> <p>Attached Information 2: Error Location Details (Rung Number). For a program section, the rung number from the start of the section is given. For ST, the line number is given.</p> <p>Attached Information 3: Names of the Instruction and Instruction Instance Where the Error Occurred. If there is more than one possible instruction, information is given on all of them. Nothing is given if the instruction cannot be identified.</p> <p>Attached Information 4: Expansion Error Code (<i>ErrorType</i>)</p>					
Precautions/Remarks	If a program is changed after an error occurs, the attached information that is displayed may not be correct.					

* Error code 16#4803 occurs for unit version 1.12 or later of the CPU Unit.

Event name	Too Many Simultaneous Instruction Executions			Event code	54014804 hex*	
Meaning	The number of instructions that can be simultaneously executed was exceeded.					
Source	PLC Function Module		Source details	Instruction	Detection timing	At instruction execution
Error attributes	Level	Observation	Recovery	---	Log category	System
Effects	User program	Continues.	Operation	The relevant instruction will end according to specifications.		
System-defined variables	Variable		Data type		Name	
	None		---	---		
Cause and correction	Assumed cause		Correction		Prevention	
	More than 32 NX message instructions and EtherCAT communications instructions were executed at the same time.		Correct the user program so that no more than 32 NX message instructions and EtherCAT communications instructions are executed at the same time.		Write the user program so that no more than 32 NX message instructions and EtherCAT communications instructions are executed at the same time.	
Attached information	<p>Attached Information 1: Error Location</p> <p>Attached Information 2: Error Location Details (Rung Number). For a program section, the rung number from the start of the section is given. For ST, the line number is given.</p> <p>Attached Information 3: Names of the Instruction and Instruction Instance Where the Error Occurred. If there is more than one possible instruction, information is given on all of them. Nothing is given if the instruction cannot be identified.</p> <p>Attached Information 4: Expansion Error Code (<i>ErrorType</i>)</p>					
Precautions/Remarks	If a program is changed after an error occurs, the attached information that is displayed may not be correct.					

* Error code 16#4804 occurs for unit version 1.12 or later of the CPU Unit.

Event name	Communications Timeout			Event code	54014805 hex*	
Meaning	A timeout occurred in communications.					
Source	PLC Function Module		Source details	Instruction	Detection timing	At instruction execution
Error attributes	Level	Observation	Recovery	---	Log category	System
Effects	User program	Continues.	Operation	The relevant instruction will end according to specifications.		
System-defined variables	Variable		Data type		Name	
	None		---	---		
Cause and correction	Assumed cause		Correction		Prevention	
	The communications timeout time is shorter than the message response time.		Calculate the message response time, and make a setting so that the communications timeout time is longer than the message response time.		Calculate the message response time, and make a setting so that the communications timeout time is longer than the message response time.	
	The cable for EtherCAT or for IO-Link is broken.		Replace the cable.		None	
	Noise		Implement noise countermeasures.		Implement noise countermeasures.	
	Device failure		Replace the relevant device.		None	
Attached information	<p>Attached Information 1: Error Location</p> <p>Attached Information 2: Error Location Details (Rung Number). For a program section, the rung number from the start of the section is given. For ST, the line number is given.</p> <p>Attached Information 3: Names of the Instruction and Instruction Instance Where the Error Occurred. If there is more than one possible instruction, information is given on all of them. Nothing is given if the instruction cannot be identified.</p> <p>Attached Information 4: Expansion Error Code (<i>ErrorType</i>)</p>					
Precautions/Remarks	If a program is changed after an error occurs, the attached information that is displayed may not be correct.					

* Error code 16#4805 occurs for unit version 1.12 or later of the CPU Unit.

Event name	Invalid Mode		Event code	54014806 hex*		
Meaning	The specified IO-Link master port is not the IO-Link mode.					
Source	PLC Function Module		Source details	Instruction	Detection timing	At instruction execution
Error attributes	Level	Observation	Recovery	---	Log category	System
Effects	User program	Continues.	Operation	The relevant instruction will end according to specifications.		
System-defined variables	Variable		Data type		Name	
	None		---		---	
Cause and correction	Assumed cause		Correction		Prevention	
	The specified IO-Link master port is not the IO-Link mode.		Set the specified IO-Link master port to the IO-Link mode, and execute the instruction again.		Set the IO-Link master port to specify to the IO-Link mode, and execute the instruction.	
Attached information	<p>Attached Information 1: Error Location</p> <p>Attached Information 2: Error Location Details (Rung Number). For a program section, the rung number from the start of the section is given. For ST, the line number is given.</p> <p>Attached Information 3: Names of the Instruction and Instruction Instance Where the Error Occurred. If there is more than one possible instruction, information is given on all of them. Nothing is given if the instruction cannot be identified.</p> <p>Attached Information 4: Expansion Error Code (<i>ErrorType</i>)</p>					
Precautions/Remarks	If a program is changed after an error occurs, the attached information that is displayed may not be correct.					

* Error code 16#4806 occurs for unit version 1.12 or later of the CPU Unit.

Event name	I/O Power OFF Status		Event code	54014807 hex*		
Meaning	The I/O power is not supplied to the specified IO-Link master port.					
Source	PLC Function Module		Source details	Instruction	Detection timing	At instruction execution
Error attributes	Level	Observation	Recovery	---	Log category	System
Effects	User program	Continues.	Operation	The relevant instruction will end according to specifications.		
System-defined variables	Variable		Data type		Name	
	None		---		---	
Cause and correction	Assumed cause		Correction		Prevention	
	The I/O power is not supplied to the specified IO-Link master port.		Supply the I/O power to the specified IO-Link master port, and then execute the instruction.		Make sure that an I/O power is supplied to the specified IO-Link master port before you execute the instruction.	
Attached information	<p>Attached Information 1: Error Location</p> <p>Attached Information 2: Error Location Details (Rung Number). For a program section, the rung number from the start of the section is given. For ST, the line number is given.</p> <p>Attached Information 3: Names of the Instruction and Instruction Instance Where the Error Occurred. If there is more than one possible instruction, information is given on all of them. Nothing is given if the instruction cannot be identified.</p> <p>Attached Information 4: Expansion Error Code (<i>ErrorType</i>)</p>					
Precautions/Remarks	If a program is changed after an error occurs, the attached information that is displayed may not be correct.					

* Error code 16#4807 occurs for unit version 1.12 or later of the CPU Unit.

Event name	Verification Error		Event code	54014808 hex*		
Meaning	The specified IO-Link master port had a verification error or a communications error.					
Source	PLC Function Module		Source details	Instruction	Detection timing	At instruction execution
Error attributes	Level	Observation	Recovery	---	Log category	System
Effects	User program	Continues.	Operation	The relevant instruction will end according to specifications.		
System-defined variables	Variable		Data type		Name	
	None		---		---	
Cause and correction	Assumed cause		Correction		Prevention	
	The specified IO-Link master port had a verification error or a communications error.		Clear the error, and then execute the instruction again.		Execute the instruction while there is no error.	
Attached information	<p>Attached Information 1: Error Location</p> <p>Attached Information 2: Error Location Details (Rung Number). For a program section, the rung number from the start of the section is given. For ST, the line number is given.</p> <p>Attached Information 3: Names of the Instruction and Instruction Instance Where the Error Occurred. If there is more than one possible instruction, information is given on all of them. Nothing is given if the instruction cannot be identified.</p> <p>Attached Information 4: Expansion Error Code (<i>ErrorType</i>)</p>					
Precautions/Remarks	If a program is changed after an error occurs, the attached information that is displayed may not be correct.					

* Error code 16#4808 occurs for unit version 1.12 or later of the CPU Unit.

Event name	Electronic Gear Ratio Numerator Setting Out of Range		Event code	54015420 hex		
Meaning	The parameter specified for the <i>RatioNumerator</i> input variable to a motion control instruction is out of range.					
Source	PLC Function Module		Source details	Instruction	Detection timing	At instruction execution
Error attributes	Level	Observation	Recovery	---	Log category	System
Effects	User program	Continues.	Operation	The relevant instruction will end according to specifications.		
System-defined variables	Variable		Data type		Name	
	_MC_AX[*].MFaultLvl.Active		BOOL		Axis Minor Fault Occurrence	
Cause and correction	Assumed cause		Correction		Prevention	
	Instruction input parameter exceeded the valid range of the input variable.		Correct the parameter so that the valid range of the input variable is not exceeded for the relevant instruction.		Set the input parameter to the instruction so that the valid range of the input variable is not exceeded.	
Attached information	<p>Attached Information 1: Error Location</p> <p>Attached Information 2: Error Location Details (Rung Number). For a program section, the rung number from the start of the section is given. For ST, the line number is given.</p> <p>Attached Information 3: Names of the Instruction and Instruction Instance Where the Error Occurred. If there is more than one possible instruction, information is given on all of them. Nothing is given if the instruction cannot be identified.</p> <p>Attached Information 4: Expansion Error Code (<i>ErrorIDEx</i>)</p>					
Precautions/Remarks	If a program is changed after an error occurs, the attached information that is displayed may not be correct.					

Event name	Electronic Gear Ratio Denominator Setting Out of Range		Event code	54015421 hex		
Meaning	The parameter specified for the <i>RatioDenominator</i> input variable to a motion control instruction is out of range.					
Source	PLC Function Module		Source details	Instruction	Detection timing	At instruction execution
Error attributes	Level	Observation	Recovery	---	Log category	System
Effects	User program	Continues.	Operation	The relevant instruction will end according to specifications.		
System-defined variables	Variable		Data type		Name	
	_MC_AX[*].MFaultLvl.Active		BOOL		Axis Minor Fault Occurrence	
Cause and correction	Assumed cause		Correction		Prevention	
	Instruction input parameter exceeded the valid range of the input variable.		Correct the parameter so that the valid range of the input variable is not exceeded for the relevant instruction.		Set the input parameter to the instruction so that the valid range of the input variable is not exceeded.	
Attached information	<p>Attached Information 1: Error Location</p> <p>Attached Information 2: Error Location Details (Rung Number). For a program section, the rung number from the start of the section is given. For ST, the line number is given.</p> <p>Attached Information 3: Names of the Instruction and Instruction Instance Where the Error Occurred. If there is more than one possible instruction, information is given on all of them. Nothing is given if the instruction cannot be identified.</p> <p>Attached Information 4: Expansion Error Code (<i>ErrorIDEx</i>)</p>					
Precautions/Remarks	If a program is changed after an error occurs, the attached information that is displayed may not be correct.					

Event name	Target Velocity Setting Out of Range			Event code	54015422 hex	
Meaning	The parameter specified for the <i>Velocity</i> input variable to a motion control instruction is out of range.					
Source	PLC Function Module		Source details	Instruction	Detection timing	At instruction execution
Error attributes	Level	Observation	Recovery	---	Log category	System
Effects	User program	Continues.	Operation	The relevant instruction will end according to specifications.		
System-defined variables	Variable		Data type		Name	
	_MC_AX[*].MFaultLvl.Active		BOOL		Axis Minor Fault Occurrence	
	_MC_GRP[*].MFaultLvl.Active		BOOL		Axes Group Minor Fault Occurrence	
Cause and correction	Assumed cause		Correction		Prevention	
	Instruction input parameter exceeded the valid range of the input variable.		Correct the parameter so that the valid range of the input variable is not exceeded for the relevant instruction.		Set the input parameter to the instruction so that the valid range of the input variable is not exceeded.	
Attached information	<p>Attached Information 1: Error Location</p> <p>Attached Information 2: Error Location Details (Rung Number). For a program section, the rung number from the start of the section is given. For ST, the line number is given.</p> <p>Attached Information 3: Names of the Instruction and Instruction Instance Where the Error Occurred. If there is more than one possible instruction, information is given on all of them. Nothing is given if the instruction cannot be identified.</p> <p>Attached Information 4: Expansion Error Code (<i>ErrorIDEx</i>)</p>					
Precautions/Remarks	If a program is changed after an error occurs, the attached information that is displayed may not be correct.					

Event name	Acceleration Setting Out of Range			Event code	54015423 hex	
Meaning	The parameter specified for the <i>Acceleration</i> input variable to a motion control instruction is out of range.					
Source	PLC Function Module		Source details	Instruction	Detection timing	At instruction execution
Error attributes	Level	Observation	Recovery	---	Log category	System
Effects	User program	Continues.	Operation	The relevant instruction will end according to specifications.		
System-defined variables	Variable		Data type		Name	
	_MC_AX[*].MFaultLvl.Active		BOOL		Axis Minor Fault Occurrence	
	_MC_GRP[*].MFaultLvl.Active		BOOL		Axes Group Minor Fault Occurrence	
Cause and correction	Assumed cause		Correction		Prevention	
	Instruction input parameter exceeded the valid range of the input variable.		Correct the parameter so that the valid range of the input variable is not exceeded for the relevant instruction.		Set the input parameter to the instruction so that the valid range of the input variable is not exceeded.	
Attached information	<p>Attached Information 1: Error Location</p> <p>Attached Information 2: Error Location Details (Rung Number). For a program section, the rung number from the start of the section is given. For ST, the line number is given.</p> <p>Attached Information 3: Names of the Instruction and Instruction Instance Where the Error Occurred. If there is more than one possible instruction, information is given on all of them. Nothing is given if the instruction cannot be identified.</p> <p>Attached Information 4: Expansion Error Code (<i>ErrorIDEx</i>)</p>					
Precautions/Remarks	If a program is changed after an error occurs, the attached information that is displayed may not be correct.					

Event name	Deceleration Setting Out of Range		Event code	54015424 hex		
Meaning	The parameter specified for the <i>Deceleration</i> input variable to a motion control instruction is out of range.					
Source	PLC Function Module		Source details	Instruction	Detection timing	At instruction execution
Error attributes	Level	Observation	Recovery	---	Log category	System
Effects	User program	Continues.	Operation	The relevant instruction will end according to specifications.		
System-defined variables	Variable		Data type		Name	
	_MC_AX[*].MFaultLvl.Active		BOOL		Axis Minor Fault Occurrence	
	_MC_GRP[*].MFaultLvl.Active		BOOL		Axes Group Minor Fault Occurrence	
Cause and correction	Assumed cause		Correction		Prevention	
	Instruction input parameter exceeded the valid range of the input variable.		Correct the parameter so that the valid range of the input variable is not exceeded for the relevant instruction.		Set the input parameter to the instruction so that the valid range of the input variable is not exceeded.	
Attached information	<p>Attached Information 1: Error Location</p> <p>Attached Information 2: Error Location Details (Rung Number). For a program section, the rung number from the start of the section is given. For ST, the line number is given.</p> <p>Attached Information 3: Names of the Instruction and Instruction Instance Where the Error Occurred. If there is more than one possible instruction, information is given on all of them. Nothing is given if the instruction cannot be identified.</p> <p>Attached Information 4: Expansion Error Code (<i>ErrorIDEx</i>)</p>					
Precautions/Remarks	If a program is changed after an error occurs, the attached information that is displayed may not be correct.					

Event name	Jerk Setting Out of Range		Event code	54015425 hex		
Meaning	The parameter specified for the <i>Jerk</i> input variable to a motion control instruction is out of range.					
Source	PLC Function Module		Source details	Instruction	Detection timing	At instruction execution
Error attributes	Level	Observation	Recovery	---	Log category	System
Effects	User program	Continues.	Operation	The relevant instruction will end according to specifications.		
System-defined variables	Variable		Data type		Name	
	_MC_AX[*].MFaultLvl.Active		BOOL		Axis Minor Fault Occurrence	
	_MC_GRP[*].MFaultLvl.Active		BOOL		Axes Group Minor Fault Occurrence	
Cause and correction	Assumed cause		Correction		Prevention	
	Instruction input parameter exceeded the valid range of the input variable.		Correct the parameter so that the valid range of the input variable is not exceeded for the relevant instruction.		Set the input parameter to the instruction so that the valid range of the input variable is not exceeded.	
Attached information	<p>Attached Information 1: Error Location</p> <p>Attached Information 2: Error Location Details (Rung Number). For a program section, the rung number from the start of the section is given. For ST, the line number is given.</p> <p>Attached Information 3: Names of the Instruction and Instruction Instance Where the Error Occurred. If there is more than one possible instruction, information is given on all of them. Nothing is given if the instruction cannot be identified.</p> <p>Attached Information 4: Expansion Error Code (<i>ErrorIDEx</i>)</p>					
Precautions/Remarks	If a program is changed after an error occurs, the attached information that is displayed may not be correct.					

Event name	Torque Ramp Setting Out of Range			Event code	5401 5427 hex	
Meaning	The parameter specified for the <i>TorqueRamp</i> input variable to a motion control instruction is out of range.					
Source	PLC Function Module		Source details	Instruction	Detection timing	At instruction execution
Error attributes	Level	Observation	Recovery	---	Log category	System
Effects	User program	Continues.	Operation	The relevant instruction will end according to specifications.		
System-defined variables	Variable		Data type		Name	
	_MC_AX[*].MFAultLvl.Active		BOOL		Axis Minor Fault Occurrence	
Cause and correction	Assumed cause		Correction		Prevention	
	Instruction input parameter exceeded the valid range of the input variable.		Correct the parameter so that the valid range of the input variable is not exceeded for the relevant instruction.		Set the input parameter to the instruction so that the valid range of the input variable is not exceeded.	
Attached information	<p>Attached Information 1: Error Location</p> <p>Attached Information 2: Error Location Details (Rung Number). For a program section, the rung number from the start of the section is given. For ST, the line number is given.</p> <p>Attached Information 3: Names of the Instruction and Instruction Instance Where the Error Occurred. If there is more than one possible instruction, information is given on all of them. Nothing is given if the instruction cannot be identified.</p> <p>Attached Information 4: Expansion Error Code (<i>ErrorIDEx</i>)</p>					
Precautions/Remarks	If a program is changed after an error occurs, the attached information that is displayed may not be correct.					

Event name	Master Coefficient Scaling Out of Range			Event code	5401 5428 hex	
Meaning	The parameter specified for the <i>MasterScaling</i> input variable to a motion control instruction is out of range.					
Source	PLC Function Module		Source details	Instruction	Detection timing	At instruction execution
Error attributes	Level	Observation	Recovery	---	Log category	System
Effects	User program	Continues.	Operation	The relevant instruction will end according to specifications.		
System-defined variables	Variable		Data type		Name	
	_MC_AX[*].MFAultLvl.Active		BOOL		Axis Minor Fault Occurrence	
Cause and correction	Assumed cause		Correction		Prevention	
	Instruction input parameter exceeded the valid range of the input variable.		Correct the parameter so that the valid range of the input variable is not exceeded for the relevant instruction.		Set the input parameter to the instruction so that the valid range of the input variable is not exceeded.	
Attached information	<p>Attached Information 1: Error Location</p> <p>Attached Information 2: Error Location Details (Rung Number). For a program section, the rung number from the start of the section is given. For ST, the line number is given.</p> <p>Attached Information 3: Names of the Instruction and Instruction Instance Where the Error Occurred. If there is more than one possible instruction, information is given on all of them. Nothing is given if the instruction cannot be identified.</p> <p>Attached Information 4: Expansion Error Code (<i>ErrorIDEx</i>)</p>					
Precautions/Remarks	If a program is changed after an error occurs, the attached information that is displayed may not be correct.					

Event name	Slave Coefficient Scaling Out of Range			Event code	54015429 hex	
Meaning	The parameter specified for the <i>SlaveScaling</i> input variable to a motion control instruction is out of range.					
Source	PLC Function Module		Source details	Instruction	Detection timing	At instruction execution
Error attributes	Level	Observation	Recovery	---	Log category	System
Effects	User program	Continues.	Operation	The relevant instruction will end according to specifications.		
System-defined variables	Variable		Data type		Name	
	_MC_AX[*].MFaultLvl.Active		BOOL		Axis Minor Fault Occurrence	
Cause and correction	Assumed cause		Correction		Prevention	
	Instruction input parameter exceeded the valid range of the input variable.		Correct the parameter so that the valid range of the input variable is not exceeded for the relevant instruction.		Set the input parameter to the instruction so that the valid range of the input variable is not exceeded.	
Attached information	<p>Attached Information 1: Error Location</p> <p>Attached Information 2: Error Location Details (Rung Number). For a program section, the rung number from the start of the section is given. For ST, the line number is given.</p> <p>Attached Information 3: Names of the Instruction and Instruction Instance Where the Error Occurred. If there is more than one possible instruction, information is given on all of them. Nothing is given if the instruction cannot be identified.</p> <p>Attached Information 4: Expansion Error Code (<i>ErrorIDEx</i>)</p>					
Precautions/Remarks	If a program is changed after an error occurs, the attached information that is displayed may not be correct.					

Event name	Feeding Velocity Setting Out of Range			Event code	5401542A hex	
Meaning	The parameter specified for the <i>FeedVelocity</i> input variable to a motion control instruction is out of range.					
Source	PLC Function Module		Source details	Instruction	Detection timing	At instruction execution
Error attributes	Level	Observation	Recovery	---	Log category	System
Effects	User program	Continues.	Operation	The relevant instruction will end according to specifications.		
System-defined variables	Variable		Data type		Name	
	_MC_AX[*].MFaultLvl.Active		BOOL		Axis Minor Fault Occurrence	
Cause and correction	Assumed cause		Correction		Prevention	
	The Feed Velocity (input variable <i>FeedVelocity</i>) is still at the default (0).		Specify a positive value for the Feed Velocity (input variable <i>FeedVelocity</i>).		Set the input parameter to the instruction so that the valid range of the input variable is not exceeded.	
Attached information	<p>Attached Information 1: Error Location</p> <p>Attached Information 2: Error Location Details (Rung Number). For a program section, the rung number from the start of the section is given. For ST, the line number is given.</p> <p>Attached Information 3: Names of the Instruction and Instruction Instance Where the Error Occurred. If there is more than one possible instruction, information is given on all of them. Nothing is given if the instruction cannot be identified.</p> <p>Attached Information 4: Expansion Error Code (<i>ErrorIDEx</i>)</p>					
Precautions/Remarks	If a program is changed after an error occurs, the attached information that is displayed may not be correct.					

Event name	Buffer Mode Selection Out of Range			Event code	5401542B hex	
Meaning	The parameter specified for the <i>BufferMode</i> input variable to a motion control instruction is out of range.					
Source	PLC Function Module		Source details	Instruction	Detection timing	At instruction execution
Error attributes	Level	Observation	Recovery	---	Log category	System
Effects	User program	Continues.	Operation	The relevant instruction will end according to specifications.		
System-defined variables	Variable		Data type		Name	
	_MC_AX[*].MFaultLvl.Active		BOOL		Axis Minor Fault Occurrence	
	_MC_GRP[*].MFaultLvl.Active		BOOL		Axes Group Minor Fault Occurrence	
Cause and correction	Assumed cause		Correction		Prevention	
	Instruction input parameter exceeded the valid range of the input variable.		Correct the parameter so that the valid range of the input variable is not exceeded for the relevant instruction.		Set the input parameter to the instruction so that the valid range of the input variable is not exceeded.	
Attached information	<p>Attached Information 1: Error Location</p> <p>Attached Information 2: Error Location Details (Rung Number). For a program section, the rung number from the start of the section is given. For ST, the line number is given.</p> <p>Attached Information 3: Names of the Instruction and Instruction Instance Where the Error Occurred. If there is more than one possible instruction, information is given on all of them. Nothing is given if the instruction cannot be identified.</p> <p>Attached Information 4: Expansion Error Code (<i>ErrorIDEx</i>)</p>					
Precautions/Remarks	If a program is changed after an error occurs, the attached information that is displayed may not be correct.					

Event name	Coordinate System Selection Out of Range			Event code	5401542C hex	
Meaning	The parameter specified for the <i>CoordSystem</i> input variable to a motion control instruction is out of range.					
Source	PLC Function Module		Source details	Instruction	Detection timing	At instruction execution
Error attributes	Level	Observation	Recovery	---	Log category	System
Effects	User program	Continues.	Operation	The relevant instruction will end according to specifications.		
System-defined variables	Variable		Data type		Name	
	_MC_GRP[*].MFaultLvl.Active		BOOL		Axes Group Minor Fault Occurrence	
Cause and correction	Assumed cause		Correction		Prevention	
	Instruction input parameter exceeded the valid range of the input variable.		Correct the parameter so that the valid range of the input variable is not exceeded for the relevant instruction.		Set the input parameter to the instruction so that the valid range of the input variable is not exceeded.	
Attached information	<p>Attached Information 1: Error Location</p> <p>Attached Information 2: Error Location Details (Rung Number). For a program section, the rung number from the start of the section is given. For ST, the line number is given.</p> <p>Attached Information 3: Names of the Instruction and Instruction Instance Where the Error Occurred. If there is more than one possible instruction, information is given on all of them. Nothing is given if the instruction cannot be identified.</p> <p>Attached Information 4: Expansion Error Code (<i>ErrorIDEx</i>)</p>					
Precautions/Remarks	If a program is changed after an error occurs, the attached information that is displayed may not be correct.					

Event name	Circular Interpolation Mode Selection Out of Range		Event code	5401542D hex		
Meaning	The parameter specified for the <i>CircMode</i> input variable to a motion control instruction is out of range.					
Source	PLC Function Module		Source details	Instruction	Detection timing	At instruction execution
Error attributes	Level	Observation	Recovery	---	Log category	System
Effects	User program	Continues.	Operation	The relevant instruction will end according to specifications.		
System-defined variables	Variable		Data type		Name	
	_MC_GRP[*].MFaultLvl.Active		BOOL		Axes Group Minor Fault Occurrence	
Cause and correction	Assumed cause		Correction		Prevention	
	Instruction input parameter exceeded the valid range of the input variable.		Correct the parameter so that the valid range of the input variable is not exceeded for the relevant instruction.		Set the input parameter to the instruction so that the valid range of the input variable is not exceeded.	
Attached information	<p>Attached Information 1: Error Location</p> <p>Attached Information 2: Error Location Details (Rung Number). For a program section, the rung number from the start of the section is given. For ST, the line number is given.</p> <p>Attached Information 3: Names of the Instruction and Instruction Instance Where the Error Occurred. If there is more than one possible instruction, information is given on all of them. Nothing is given if the instruction cannot be identified.</p> <p>Attached Information 4: Expansion Error Code (<i>ErrorIDEx</i>)</p>					
Precautions/Remarks	If a program is changed after an error occurs, the attached information that is displayed may not be correct.					

Event name	Direction Selection Out of Range		Event code	5401542E hex		
Meaning	The parameter specified for the <i>Direction</i> input variable to a motion control instruction is out of range.					
Source	PLC Function Module		Source details	Instruction	Detection timing	At instruction execution
Error attributes	Level	Observation	Recovery	---	Log category	System
Effects	User program	Continues.	Operation	The relevant instruction will end according to specifications.		
System-defined variables	Variable		Data type		Name	
	_MC_AX[*].MFaultLvl.Active		BOOL		Axis Minor Fault Occurrence	
Cause and correction	Assumed cause		Correction		Prevention	
	Instruction input parameter exceeded the valid range of the input variable.		Correct the parameter so that the valid range of the input variable is not exceeded for the relevant instruction.		Set the input parameter to the instruction so that the valid range of the input variable is not exceeded.	
Attached information	<p>Attached Information 1: Error Location</p> <p>Attached Information 2: Error Location Details (Rung Number). For a program section, the rung number from the start of the section is given. For ST, the line number is given.</p> <p>Attached Information 3: Names of the Instruction and Instruction Instance Where the Error Occurred. If there is more than one possible instruction, information is given on all of them. Nothing is given if the instruction cannot be identified.</p> <p>Attached Information 4: Expansion Error Code (<i>ErrorIDEx</i>)</p>					
Precautions/Remarks	If a program is changed after an error occurs, the attached information that is displayed may not be correct.					

Event name	Path Selection Out of Range			Event code	5401542F hex	
Meaning	The parameter specified for the <i>PathChoice</i> input variable to a motion control instruction is out of range.					
Source	PLC Function Module		Source details	Instruction	Detection timing	At instruction execution
Error attributes	Level	Observation	Recovery	---	Log category	System
Effects	User program	Continues.	Operation	The relevant instruction will end according to specifications.		
System-defined variables	Variable		Data type		Name	
	_MC_GRP[*].MFaultLvl.Active		BOOL		Axes Group Minor Fault Occurrence	
Cause and correction	Assumed cause		Correction		Prevention	
	Instruction input parameter exceeded the valid range of the input variable.		Correct the parameter so that the valid range of the input variable is not exceeded for the relevant instruction.		Set the input parameter to the instruction so that the valid range of the input variable is not exceeded.	
Attached information	<p>Attached Information 1: Error Location</p> <p>Attached Information 2: Error Location Details (Rung Number). For a program section, the rung number from the start of the section is given. For ST, the line number is given.</p> <p>Attached Information 3: Names of the Instruction and Instruction Instance Where the Error Occurred. If there is more than one possible instruction, information is given on all of them. Nothing is given if the instruction cannot be identified.</p> <p>Attached Information 4: Expansion Error Code (<i>ErrorIDEx</i>)</p>					
Precautions/Remarks	If a program is changed after an error occurs, the attached information that is displayed may not be correct.					

Event name	Position Type Selection Out of Range			Event code	54015430 hex	
Meaning	The parameter specified for the <i>ReferenceType</i> input variable to a motion control instruction is out of range.					
Source	PLC Function Module		Source details	Instruction	Detection timing	At instruction execution
Error attributes	Level	Observation	Recovery	---	Log category	System
Effects	User program	Continues.	Operation	The relevant instruction will end according to specifications.		
System-defined variables	Variable		Data type		Name	
	_MC_COM.MFaultLvl.Active		BOOL		MC Common Minor Fault Occurrence	
	_MC_AX[*].MFaultLvl.Active		BOOL		Axis Minor Fault Occurrence	
Cause and correction	Assumed cause		Correction		Prevention	
	Instruction input parameter exceeded the valid range of the input variable.		Correct the parameter so that the valid range of the input variable is not exceeded for the relevant instruction.		Set the input parameter to the instruction so that the valid range of the input variable is not exceeded.	
Attached information	<p>Attached Information 1: Error Location</p> <p>Attached Information 2: Error Location Details (Rung Number). For a program section, the rung number from the start of the section is given. For ST, the line number is given.</p> <p>Attached Information 3: Names of the Instruction and Instruction Instance Where the Error Occurred. If there is more than one possible instruction, information is given on all of them. Nothing is given if the instruction cannot be identified.</p> <p>Attached Information 4: Expansion Error Code (<i>ErrorIDEx</i>)</p>					
Precautions/Remarks	If a program is changed after an error occurs, the attached information that is displayed may not be correct.					

Event name	Travel Mode Selection Out of Range		Event code	54015431 hex		
Meaning	The parameter specified for the <i>MoveMode</i> input variable to a motion control instruction is out of range.					
Source	PLC Function Module		Source details	Instruction	Detection timing	At instruction execution
Error attributes	Level	Observation	Recovery	---	Log category	System
Effects	User program	Continues.	Operation	The relevant instruction will end according to specifications.		
System-defined variables	Variable		Data type		Name	
	_MC_AX[*].MFaultLvl.Active		BOOL		Axis Minor Fault Occurrence	
	_MC_GRP[*].MFaultLvl.Active		BOOL		Axes Group Minor Fault Occurrence	
Cause and correction	Assumed cause		Correction		Prevention	
	Instruction input parameter exceeded the valid range of the input variable.		Correct the parameter so that the valid range of the input variable is not exceeded for the relevant instruction.		Set the input parameter to the instruction so that the valid range of the input variable is not exceeded.	
Attached information	<p>Attached Information 1: Error Location</p> <p>Attached Information 2: Error Location Details (Rung Number). For a program section, the rung number from the start of the section is given. For ST, the line number is given.</p> <p>Attached Information 3: Names of the Instruction and Instruction Instance Where the Error Occurred. If there is more than one possible instruction, information is given on all of them. Nothing is given if the instruction cannot be identified.</p> <p>Attached Information 4: Expansion Error Code (<i>ErrorIDEx</i>)</p>					
Precautions/Remarks	If a program is changed after an error occurs, the attached information that is displayed may not be correct.					

Event name	Transition Mode Selection Out of Range		Event code	54015432 hex		
Meaning	The parameter specified for the <i>TransitionMode</i> input variable to a motion control instruction is out of range.					
Source	PLC Function Module		Source details	Instruction	Detection timing	At instruction execution
Error attributes	Level	Observation	Recovery	---	Log category	System
Effects	User program	Continues.	Operation	The relevant instruction will end according to specifications.		
System-defined variables	Variable		Data type		Name	
	_MC_GRP[*].MFaultLvl.Active		BOOL		Axes Group Minor Fault Occurrence	
Cause and correction	Assumed cause		Correction		Prevention	
	Instruction input parameter exceeded the valid range of the input variable.		Correct the parameter so that the valid range of the input variable is not exceeded for the relevant instruction.		Set the input parameter to the instruction so that the valid range of the input variable is not exceeded.	
	_mcAborting or _mcBuffered was specified for <i>BufferMode</i> and _mcTMCornerSuperimposed was specified for <i>TransitionMode</i> .		If you specify _mcAborting or _mcBuffered for <i>BufferMode</i> , specify _mcTMNone for <i>TransitionMode</i> . If you specify _mcTMCornerSuperimposed for <i>TransitionMode</i> , specify _mcBlendingLow, _mcBlendingPrevious, _mcBlendingNext, or _mcBlendingHigh for <i>BufferMode</i> .		If you specify _mcAborting or _mcBuffered for <i>BufferMode</i> , specify _mcTMNone for <i>TransitionMode</i> . If you specify _mcTMCornerSuperimposed for <i>TransitionMode</i> , specify _mcBlendingLow, _mcBlendingPrevious, _mcBlendingNext, or _mcBlendingHigh for <i>BufferMode</i> .	
Attached information	<p>Attached Information 1: Error Location</p> <p>Attached Information 2: Error Location Details (Rung Number). For a program section, the rung number from the start of the section is given. For ST, the line number is given.</p> <p>Attached Information 3: Names of the Instruction and Instruction Instance Where the Error Occurred. If there is more than one possible instruction, information is given on all of them. Nothing is given if the instruction cannot be identified.</p> <p>Attached Information 4: Expansion Error Code (<i>ErrorIDEx</i>)</p>					
Precautions/Remarks	If a program is changed after an error occurs, the attached information that is displayed may not be correct.					

Event name	Continue Method Selection Out of Range			Event code	5401 5433 hex	
Meaning	The value of the reserved input variable <i>Continuous</i> to a motion control instruction changed.					
Source	PLC Function Module		Source details	Instruction	Detection timing	At instruction execution
Error attributes	Level	Observation	Recovery	---	Log category	System
Effects	User program	Continues.	Operation	The relevant instruction will end according to specifications.		
System-defined variables	Variable		Data type		Name	
	_MC_AX[*].MFaultLvl.Active		BOOL		Axis Minor Fault Occurrence	
Cause and correction	Assumed cause		Correction		Prevention	
	The value of the reserved input variable <i>Continuous</i> changed.		Correct the program so that the value of the reserved input variable <i>Continuous</i> does not change.		Write the user program so that the value of the reserved input variable <i>Continuous</i> does not change.	
Attached information	<p>Attached Information 1: Error Location</p> <p>Attached Information 2: Error Location Details (Rung Number). For a program section, the rung number from the start of the section is given. For ST, the line number is given.</p> <p>Attached Information 3: Names of the Instruction and Instruction Instance Where the Error Occurred. If there is more than one possible instruction, information is given on all of them. Nothing is given if the instruction cannot be identified.</p> <p>Attached Information 4: Expansion Error Code (<i>ErrorIDEx</i>)</p>					
Precautions/Remarks	If a program is changed after an error occurs, the attached information that is displayed may not be correct.					

Event name	Combine Mode Selection Out of Range			Event code	5401 5434 hex	
Meaning	The parameter specified for the <i>CombineMode</i> input variable to a motion control instruction is out of range.					
Source	PLC Function Module		Source details	Instruction	Detection timing	At instruction execution
Error attributes	Level	Observation	Recovery	---	Log category	System
Effects	User program	Continues.	Operation	The relevant instruction will end according to specifications.		
System-defined variables	Variable		Data type		Name	
	_MC_AX[*].MFaultLvl.Active		BOOL		Axis Minor Fault Occurrence	
Cause and correction	Assumed cause		Correction		Prevention	
	Instruction input parameter exceeded the valid range of the input variable.		Correct the parameter so that the valid range of the input variable is not exceeded for the relevant instruction.		Set the input parameter to the instruction so that the valid range of the input variable is not exceeded.	
Attached information	<p>Attached Information 1: Error Location</p> <p>Attached Information 2: Error Location Details (Rung Number). For a program section, the rung number from the start of the section is given. For ST, the line number is given.</p> <p>Attached Information 3: Names of the Instruction and Instruction Instance Where the Error Occurred. If there is more than one possible instruction, information is given on all of them. Nothing is given if the instruction cannot be identified.</p> <p>Attached Information 4: Expansion Error Code (<i>ErrorIDEx</i>)</p>					
Precautions/Remarks	If a program is changed after an error occurs, the attached information that is displayed may not be correct.					

Event name	Synchronization Start Condition Selection Out of Range		Event code	54015435 hex		
Meaning	The parameter specified for the <i>LinkOption</i> input variable to a motion control instruction is out of range.					
Source	PLC Function Module		Source details	Instruction	Detection timing	At instruction execution
Error attributes	Level	Observation	Recovery	---	Log category	System
Effects	User program	Continues.	Operation	The relevant instruction will end according to specifications.		
System-defined variables	Variable		Data type		Name	
	_MC_AX[*].MFaultLvl.Active		BOOL		Axis Minor Fault Occurrence	
Cause and correction	Assumed cause		Correction		Prevention	
	Instruction input parameter exceeded the valid range of the input variable.		Correct the parameter so that the valid range of the input variable is not exceeded for the relevant instruction.		Set the input parameter to the instruction so that the valid range of the input variable is not exceeded.	
Attached information	<p>Attached Information 1: Error Location</p> <p>Attached Information 2: Error Location Details (Rung Number). For a program section, the rung number from the start of the section is given. For ST, the line number is given.</p> <p>Attached Information 3: Names of the Instruction and Instruction Instance Where the Error Occurred. If there is more than one possible instruction, information is given on all of them. Nothing is given if the instruction cannot be identified.</p> <p>Attached Information 4: Expansion Error Code (<i>ErrorIDEx</i>)</p>					
Precautions/Remarks	If a program is changed after an error occurs, the attached information that is displayed may not be correct.					

Event name	Master and Slave Defined as Same Axis		Event code	54015436 hex		
Meaning	The same axis is specified for the <i>Master</i> and <i>Slave</i> input variables to a motion control instruction.					
Source	PLC Function Module		Source details	Instruction	Detection timing	At instruction execution
Error attributes	Level	Observation	Recovery	---	Log category	System
Effects	User program	Continues.	Operation	The relevant instruction will end according to specifications.		
System-defined variables	Variable		Data type		Name	
	_MC_COM.MFaultLvl.Active		BOOL		MC Common Minor Fault Occurrence	
	_MC_AX[*].MFaultLvl.Active		BOOL		Axis Minor Fault Occurrence	
Cause and correction	Assumed cause		Correction		Prevention	
	The parameter is the same for the <i>Master</i> and <i>Slave</i> input variables to the instruction.		Correct the parameters so that different axes are specified for the <i>Master</i> and <i>Slave</i> input variables to the instruction.		Specify different axes for the <i>Master</i> and <i>Slave</i> input variables to the instruction.	
Attached information	<p>Attached Information 1: Error Location</p> <p>Attached Information 2: Error Location Details (Rung Number). For a program section, the rung number from the start of the section is given. For ST, the line number is given.</p> <p>Attached Information 3: Names of the Instruction and Instruction Instance Where the Error Occurred. If there is more than one possible instruction, information is given on all of them. Nothing is given if the instruction cannot be identified.</p> <p>Attached Information 4: Expansion Error Code (<i>ErrorIDEx</i>)</p>					
Precautions/Remarks	If a program is changed after an error occurs, the attached information that is displayed may not be correct.					

Event name	Master and Auxiliary Defined as Same Axis			Event code	54015437 hex	
Meaning	The same axis is specified for the <i>Master</i> and <i>Auxiliary</i> input variables to a motion control instruction.					
Source	PLC Function Module		Source details	Instruction	Detection timing	At instruction execution
Error attributes	Level	Observation	Recovery	---	Log category	System
Effects	User program	Continues.	Operation	The relevant instruction will end according to specifications.		
System-defined variables	Variable		Data type		Name	
	_MC_AX[*].MFaultLvl.Active		BOOL		Axis Minor Fault Occurrence	
Cause and correction	Assumed cause		Correction		Prevention	
	The parameter is the same for the <i>Master</i> and <i>Auxiliary</i> input variables to the instruction.		Correct the parameters so that different axes are specified for the <i>Master</i> and <i>Auxiliary</i> input variables to the instruction.		Specify different axes for the <i>Master</i> and <i>Auxiliary</i> input variables to the instruction.	
Attached information	<p>Attached Information 1: Error Location</p> <p>Attached Information 2: Error Location Details (Rung Number). For a program section, the rung number from the start of the section is given. For ST, the line number is given.</p> <p>Attached Information 3: Names of the Instruction and Instruction Instance Where the Error Occurred. If there is more than one possible instruction, information is given on all of them. Nothing is given if the instruction cannot be identified.</p> <p>Attached Information 4: Expansion Error Code (<i>ErrorIDEx</i>)</p>					
Precautions/Remarks	If a program is changed after an error occurs, the attached information that is displayed may not be correct.					

Event name	Master/Slave Axis Numbers Not in Ascending Order			Event code	54015438 hex	
Meaning	The axis numbers specified for the <i>Master</i> and <i>Slave</i> input variables to a motion control instruction are not in ascending order.					
Source	PLC Function Module		Source details	Instruction	Detection timing	At instruction execution
Error attributes	Level	Observation	Recovery	---	Log category	System
Effects	User program	Continues.	Operation	The relevant instruction will end according to specifications.		
System-defined variables	Variable		Data type		Name	
	_MC_AX[*].MFaultLvl.Active		BOOL		Axis Minor Fault Occurrence	
Cause and correction	Assumed cause		Correction		Prevention	
	The parameters for the <i>Master</i> and <i>Slave</i> input variables to the instruction were not in ascending order when <i>_mcLatestCommand</i> was specified for the <i>ReferenceType</i> input variable to the instruction.		When specifying <i>_mcLatestCommand</i> for the <i>ReferenceType</i> input variable to the instruction, correct the parameters so that the axis numbers specified for the <i>Master</i> and <i>Slave</i> input variables to the instruction are in ascending order. Or, specify <i>_mcCommand</i> for the Master Axis Position Type Selection.		When specifying <i>_mcLatestCommand</i> for the <i>ReferenceType</i> input variable, make sure to specify the master axis and slave axis input variables so that they are in ascending order.	
Attached information	<p>Attached Information 1: Error Location</p> <p>Attached Information 2: Error Location Details (Rung Number). For a program section, the rung number from the start of the section is given. For ST, the line number is given.</p> <p>Attached Information 3: Names of the Instruction and Instruction Instance Where the Error Occurred. If there is more than one possible instruction, information is given on all of them. Nothing is given if the instruction cannot be identified.</p> <p>Attached Information 4: Expansion Error Code (<i>ErrorIDEx</i>)</p>					
Precautions/Remarks	If a program is changed after an error occurs, the attached information that is displayed may not be correct.					

Event name	Incorrect Cam Table Specification		Event code	54015439 hex		
Meaning	The parameter specified for the <i>CamTable</i> input variable to a motion control instruction is out of range.					
Source	PLC Function Module		Source details	Instruction	Detection timing	At instruction execution
Error attributes	Level	Observation	Recovery	---	Log category	System
Effects	User program	Continues.	Operation	The relevant instruction will end according to specifications.		
System-defined variables	Variable		Data type		Name	
	_MC_COM.MFaultLvl.Active		BOOL		MC Common Minor Fault Occurrence	
	_MC_AX[*].MFaultLvl.Active		BOOL		Axis Minor Fault Occurrence	
Cause and correction	Assumed cause		Correction		Prevention	
	Something other than a cam data variable was specified for the <i>CamTable</i> input variable to the instruction.		Correct the parameter specified for the <i>CamTable</i> input variable to the instruction so that it is a cam data variable.		Specify a cam data variable for the <i>CamTable</i> input variable to the instruction.	
Attached information	<p>Attached Information 1: Error Location</p> <p>Attached Information 2: Error Location Details (Rung Number). For a program section, the rung number from the start of the section is given. For ST, the line number is given.</p> <p>Attached Information 3: Names of the Instruction and Instruction Instance Where the Error Occurred. If there is more than one possible instruction, information is given on all of them. Nothing is given if the instruction cannot be identified.</p> <p>Attached Information 4: Expansion Error Code (<i>ErrorIDEx</i>)</p>					
Precautions/Remarks	If a program is changed after an error occurs, the attached information that is displayed may not be correct.					

Event name	Synchronization Stopped			Event code	5401 543A hex	
Meaning	A synchronized control motion control instruction was executed, but conditions required for execution were not met.					
Source	PLC Function Module		Source details	Instruction	Detection timing	At instruction execution
Error attributes	Level	Observation	Recovery	---	Log category	System
Effects	User program	Continues.	Operation	The relevant instruction will end according to specifications.		
System-defined variables	Variable		Data type		Name	
	_MC_AX[*].MFaultLvl.Active		BOOL		Axis Minor Fault Occurrence	
Cause and correction	Assumed cause		Correction		Prevention	
	<ul style="list-style-type: none"> The MC_CamOut (End Cam Operation) instruction was executed even though the MC_CamIn (Start Cam Operation) instruction is not being executed. The MC_GearOut (End Gear Operation) instruction was executed even though the MC_GearIn (Start Gear Operation) or the MC_GearInPos (Positioning Gear Operation) instruction is not being executed. The MC_Phasing (Shift Master Axis Phase) instruction was executed even though the MC_CamIn (Start Cam Operation), MC_GearIn (Start Gear Operation), MC_GearInPos (Start Gear Operation), or MC_MoveLink (Synchronous Positioning) instruction is not being executed. 		Correct the program so that required conditions are met when the instruction is executed.		Make sure that required conditions for execution are met when you execute synchronized control instructions.	
Attached information	<p>Attached Information 1: Error Location</p> <p>Attached Information 2: Error Location Details (Rung Number). For a program section, the rung number from the start of the section is given. For ST, the line number is given.</p> <p>Attached Information 3: Names of the Instruction and Instruction Instance Where the Error Occurred. If there is more than one possible instruction, information is given on all of them. Nothing is given if the instruction cannot be identified.</p> <p>Attached Information 4: Expansion Error Code (<i>ErrorIDEx</i>)</p>					
Precautions/Remarks	If a program is changed after an error occurs, the attached information that is displayed may not be correct.					

Event name	Motion Control Instruction Re-execution Disabled		Event code	5401543B hex		
Meaning	An attempt was made to re-execute a motion control instruction that cannot be re-executed.					
Source	PLC Function Module		Source details	Instruction	Detection timing	At instruction execution
Error attributes	Level	Observation	Recovery	---	Log category	System
Effects	User program	Continues.	Operation	The relevant instruction will end according to specifications.		
System-defined variables	Variable		Data type		Name	
	_MC_COM.MFaultLvl.Active		BOOL		MC Common Minor Fault Occurrence	
	_MC_AX[*].MFaultLvl.Active		BOOL		Axis Minor Fault Occurrence	
	_MC_GRP[*].MFaultLvl.Active		BOOL		Axes Group Minor Fault Occurrence	
Cause and correction	Assumed cause		Correction		Prevention	
	A motion control instruction that cannot be re-executed was re-executed.		Correct the program so that the <i>Execute</i> input variable does not change to TRUE until the <i>Busy</i> output variable from the instruction changes to FALSE.		When using instructions that cannot be re-executed, include a condition for the <i>Execute</i> input variable so that it does not change to TRUE unless the <i>Busy</i> output variable for the previous instruction is FALSE. Or, stop the instruction before executing it again.	
Attached information	<p>Attached Information 1: Error Location</p> <p>Attached Information 2: Error Location Details (Rung Number). For a program section, the rung number from the start of the section is given. For ST, the line number is given.</p> <p>Attached Information 3: Names of the Instruction and Instruction Instance Where the Error Occurred. If there is more than one possible instruction, information is given on all of them. Nothing is given if the instruction cannot be identified.</p> <p>Attached Information 4: Expansion Error Code (<i>ErrorIDEx</i>)</p>					
Precautions/Remarks	If a program is changed after an error occurs, the attached information that is displayed may not be correct.					

Event name	Motion Control Instruction Multi-execution Disabled		Event code	5401543C hex		
Meaning	Multiple functions that cannot be executed simultaneously were executed for the same target (MC common, axis, or axes group).					
Source	PLC Function Module		Source details	Instruction	Detection timing	At multi-execution of instructions
Error attributes	Level	Observation	Recovery	---	Log category	System
Effects	User program	Continues.	Operation	The relevant instruction will end according to specifications.		
System-defined variables	Variable		Data type		Name	
	_MC_COM.MFaultLvl.Active		BOOL		MC Common Minor Fault Occurrence	
	_MC_AX[*].MFaultLvl.Active		BOOL		Axis Minor Fault Occurrence	
	_MC_GRP[*].MFaultLvl.Active		BOOL		Axes Group Minor Fault Occurrence	
Cause and correction	Assumed cause		Correction		Prevention	
	Multiple functions that cannot be executed simultaneously were executed for the same target (MC common or axis).		Check the specifications of multi-execution of instructions for this instruction and correct the program so that instructions that cannot be executed at the same time are not executed simultaneously.		Check the specifications for multi-execution of instructions for the instruction and do not execute instructions that cannot be executed at the same time.	
Attached information	<p>Attached Information 1: Error Location</p> <p>Attached Information 2: Error Location Details (Rung Number). For a program section, the rung number from the start of the section is given. For ST, the line number is given.</p> <p>Attached Information 3: Names of the Instruction and Instruction Instance Where the Error Occurred. If there is more than one possible instruction, information is given on all of them. Nothing is given if the instruction cannot be identified.</p> <p>Attached Information 4: Expansion Error Code (<i>ErrorIDEx</i>)</p>					
Precautions/Remarks	If a program is changed after an error occurs, the attached information that is displayed may not be correct.					

Event name	Instruction Not Allowed for Encoder Axis Type			Event code	5401543D hex	
Meaning	An operation instruction was executed for an encoder axis.					
Source	PLC Function Module		Source details	Instruction	Detection timing	At instruction execution
Error attributes	Level	Observation	Recovery	---	Log category	System
Effects	User program	Continues.	Operation	The relevant instruction will end according to specifications.		
System-defined variables	Variable		Data type		Name	
	_MC_AX[*].MFAultLvl.Active		BOOL		Axis Minor Fault Occurrence	
Cause and correction	Assumed cause		Correction		Prevention	
	An operation instruction was executed for an encoder axis.		Specify either a Servo axis or virtual Servo axis as the axis type for the instruction, or correct the program so that the instruction is not executed for an encoder axis.		Only execute motion instructions for Servo axes or virtual Servo axes.	
Attached information	<p>Attached Information 1: Error Location</p> <p>Attached Information 2: Error Location Details (Rung Number). For a program section, the rung number from the start of the section is given. For ST, the line number is given.</p> <p>Attached Information 3: Names of the Instruction and Instruction Instance Where the Error Occurred. If there is more than one possible instruction, information is given on all of them. Nothing is given if the instruction cannot be identified.</p> <p>Attached Information 4: Expansion Error Code (<i>ErrorIDEx</i>)</p>					
Precautions/Remarks	If a program is changed after an error occurs, the attached information that is displayed may not be correct.					

Event name	Instruction Cannot Be Executed during Multi-axes Coordinated Control			Event code	5401543E hex	
Meaning	<ul style="list-style-type: none"> An operation instruction was executed for an axis or an axes group that was in a coordinated multi-axes motion. A robot instruction that you cannot use for an axes group in a <i>GroupEnable</i> state was executed. 					
Source	PLC Function Module		Source details	Instruction	Detection timing	At multi-execution of instructions
Error attributes	Level	Observation	Recovery	---	Log category	System
Effects	User program	Continues.	Operation	The relevant instruction will end according to specifications.		
System-defined variables	Variable		Data type		Name	
	_MC_AX[*].MFAultLvl.Active		BOOL		Axis Minor Fault Occurrence	
	_MC_GRP[*].MFAultLvl.Active		BOOL		Axes Group Minor Fault Occurrence	
Cause and correction	Assumed cause		Correction		Prevention	
	An operation instruction was executed for an axis or an axes group that was in a coordinated multi-axes motion.		Correct the program so that axis operation instructions are executed only for axes or axes groups that are not in coordinated multi-axes motion.		Execute axis operation instructions only for axes or axes groups that are not in coordinated multi-axes motion.	
	The MC_SetKinTransform (Set Kinematics Transformation) instruction was executed for an axes group in a <i>GroupEnable</i> state.		Correct the program so that the instruction is executed only when the axes group is in a <i>GroupDisable</i> state.		Execute the instruction only when the axes group is in a <i>GroupDisable</i> state.	
Attached information	<p>Attached Information 1: Error Location</p> <p>Attached Information 2: Error Location Details (Rung Number). For a program section, the rung number from the start of the section is given. For ST, the line number is given.</p> <p>Attached Information 3: Names of the Instruction and Instruction Instance Where the Error Occurred. If there is more than one possible instruction, information is given on all of them. Nothing is given if the instruction cannot be identified.</p> <p>Attached Information 4: Expansion Error Code (<i>ErrorIDEx</i>)</p>					
Precautions/Remarks	If a program is changed after an error occurs, the attached information that is displayed may not be correct.					

Event name	Multi-axes Coordinated Control Instruction Executed for Disabled Axes Group		Event code	5401543F hex		
Meaning	A multi-axes coordinated control instruction was executed for an axes group that was in the Axes Group Disabled state.					
Source	PLC Function Module		Source details	Instruction	Detection timing	At instruction execution
Error attributes	Level	Observation	Recovery	---	Log category	System
Effects	User program	Continues.	Operation	The relevant instruction will end according to specifications.		
System-defined variables	Variable		Data type		Name	
	_MC_GRP[*].MFaultLvl.Active		BOOL		Axes Group Minor Fault Occurrence	
Cause and correction	Assumed cause		Correction		Prevention	
	<p>A multi-axes coordinated control instruction was executed for an axes group that was in the Axes Group Disabled state.</p> <p>One of the following instructions was executed for an axes group that was in a <i>GroupDisable</i> state.</p> <ul style="list-style-type: none"> • MC_MoveTimeAbsolute (Time-specified Absolute Positioning) instruction • MC_SyncLinearConveyor (Start Conveyor Synchronization) instruction • MC_SyncOut (End Synchronization) instruction • MC_RobotJog (Axes Group Jog) instruction 		<p>Correct the program so that the instruction is executed only after changing the axes group to the Axes Group Enabled state. Execute the MC_GroupEnable (Enable Axes Group) instruction to change an axes group to the Axes Group Enabled state.</p>		<p>Execute multi-axes coordinated operation instructions only after enabling the axes group. Execute the MC_GroupEnable (Enable Axes Group) instruction to change an axes group to the Axes Group Enabled state.</p>	
Attached information	<p>Attached Information 1: Error Location</p> <p>Attached Information 2: Error Location Details (Rung Number). For a program section, the rung number from the start of the section is given. For ST, the line number is given.</p> <p>Attached Information 3: Names of the Instruction and Instruction Instance Where the Error Occurred. If there is more than one possible instruction, information is given on all of them. Nothing is given if the instruction cannot be identified.</p> <p>Attached Information 4: Expansion Error Code (<i>ErrorIDEx</i>)</p>					
Precautions/Remarks	If a program is changed after an error occurs, the attached information that is displayed may not be correct.					

Event name	Axes Group Cannot Be Enabled			Event code	54015440 hex	
Meaning	Execution of the MC_GroupEnable (Enable Axes Group) instruction failed.					
Source	PLC Function Module		Source details	Instruction	Detection timing	At instruction execution
Error attributes	Level	Observation	Recovery	---	Log category	System
Effects	User program	Continues.	Operation	The relevant instruction will end according to specifications.		
System-defined variables	Variable		Data type		Name	
	_MC_GRP[*].MFaultLvl.Active		BOOL		Axes Group Minor Fault Occurrence	
Cause and correction	Assumed cause		Correction		Prevention	
	When the MC_GroupEnable (Enable Axes Group) instruction was executed, there was a composition axis that was not stopped.		Correct the program so that the MC_GroupEnable (Enable Axes Group) instruction is executed only when all composition axes are stopped. An axis is stopped if <i>Status.Disabled</i> or <i>Status.Standstill</i> is TRUE in the Axis Variable.		Write the programs so that the MC_GroupEnable (Enable Axes Group) instruction is executed only when all composition axes are stopped. An axis is stopped if <i>Status.Disabled</i> or <i>Status.Standstill</i> is TRUE in the Axis Variable.	
	When the MC_GroupEnable (Enable Axes Group) instruction was executed, there was a composition axis for which the MC_TouchProbe (Enable External Latch) instruction was being executed.		Correct the program so that the MC_GroupEnable (Enable Axes Group) instruction is executed only when the MC_TouchProbe (Enable External Latch) instruction is not being executed for any of the composition axes.		Write the program so that the MC_GroupEnable (Enable Axes Group) instruction is executed only when the MC_TouchProbe (Enable External Latch) instruction is not being executed for any of the composition axes.	
Attached information	<p>Attached Information 1: Error Location</p> <p>Attached Information 2: Error Location Details (Rung Number). For a program section, the rung number from the start of the section is given. For ST, the line number is given.</p> <p>Attached Information 3: Names of the Instruction and Instruction Instance Where the Error Occurred. If there is more than one possible instruction, information is given on all of them. Nothing is given if the instruction cannot be identified.</p> <p>Attached Information 4: Expansion Error Code (<i>ErrorIDEx</i>)</p>					
Precautions/Remarks	If a program is changed after an error occurs, the attached information that is displayed may not be correct.					

Event name	Impossible Axis Operation Specified when the Servo is OFF		Event code	54015441 hex		
Meaning	An operation instruction was executed for an axis for which the Servo is OFF.					
Source	PLC Function Module		Source details	Instruction	Detection timing	At instruction execution
Error attributes	Level	Observation	Recovery	---	Log category	System
Effects	User program	Continues.	Operation	The relevant instruction will end according to specifications.		
System-defined variables	Variable		Data type		Name	
	_MC_AX[*].MFaultLvl.Active		BOOL		Axis Minor Fault Occurrence	
	_MC_GRP[*].MFaultLvl.Active		BOOL		Axes Group Minor Fault Occurrence	
Cause and correction	Assumed cause		Correction		Prevention	
	An operation instruction was executed for an axis for which the Servo is OFF.		Correct the program so that the instruction is executed after the Servo is turned ON.		Make sure to execute the axis operation instruction after the Servo is turned ON.	
	Home was preset with the MC_Home or MC_HomeWithParameter instruction for an axis for which EtherCAT process data communications are not established.		If the <i>_EC_PDSlavTbl</i> (Process Data Communicating Slave Table) system-defined variable for the EtherCAT master of the master axis is FALSE, remove the cause and execute the MC_Home or MC_HomeWithParameter instruction to preset home after <i>_EC_PDSlavTbl</i> changes to TRUE.		If you execute the MC_Home or MC_HomeWithParameter instruction to preset home immediately after you turn ON the power supply to the Controller, download data, reset a slave communications error, disconnect the slave, reconnect the slave, enable the slave, or disable the slave, write the program to make sure that the <i>_EC_PDSlavTbl</i> (Process Data Communicating Slave Table) system-defined variable for the EtherCAT master is TRUE before you execute MC_Home or MC_HomeWithParameter.	
Attached information	<p>Attached Information 1: Error Location</p> <p>Attached Information 2: Error Location Details (Rung Number). For a program section, the rung number from the start of the section is given. For ST, the line number is given.</p> <p>Attached Information 3: Names of the Instruction and Instruction Instance Where the Error Occurred. If there is more than one possible instruction, information is given on all of them. Nothing is given if the instruction cannot be identified.</p> <p>Attached Information 4: Expansion Error Code (<i>ErrorIDEx</i>)</p>					
Precautions/Remarks	If a program is changed after an error occurs, the attached information that is displayed may not be correct.					

Event name	Composition Axis Stopped Error		Event code	54015442 hex		
Meaning	A motion instruction was executed for an axes group while the MC_Stop instruction was being executed for a composition axis.					
Source	PLC Function Module		Source details	Instruction	Detection timing	At instruction execution
Error attributes	Level	Observation	Recovery	---	Log category	System
Effects	User program	Continues.	Operation	The relevant instruction will end according to specifications.		
System-defined variables	Variable		Data type		Name	
	_MC_GRP[*].MFaultLvl.Active		BOOL		Axes Group Minor Fault Occurrence	
Cause and correction	Assumed cause		Correction		Prevention	
	A motion instruction was executed for an axes group while the MC_Stop instruction was being executed for a composition axis.		Change the <i>Execute</i> input variable to the MC_Stop instruction for the composition axis to FALSE, reset the error, and then execute the motion control instruction.		Change the <i>Execute</i> input variables to the MC_Stop instructions for all of the composition axes to FALSE before you execute motion control instruction.	
Attached information	<p>Attached Information 1: Error Location</p> <p>Attached Information 2: Error Location Details (Rung Number). For a program section, the rung number from the start of the section is given. For ST, the line number is given.</p> <p>Attached Information 3: Names of the Instruction and Instruction Instance Where the Error Occurred. If there is more than one possible instruction, information is given on all of them. Nothing is given if the instruction cannot be identified.</p> <p>Attached Information 4: Expansion Error Code (<i>ErrorIDEx</i>)</p>					
Precautions/Remarks	If a program is changed after an error occurs, the attached information that is displayed may not be correct.					

Event name	Motion Control Instruction Multi-execution Buffer Limit Exceeded		Event code	54015443 hex		
Meaning	The number of motion control instructions that is buffered for Buffered or Blending Buffer Modes exceeded the buffer limit.					
Source	PLC Function Module		Source details	Instruction	Detection timing	At multi-execution of instructions
Error attributes	Level	Observation	Recovery	---	Log category	System
Effects	User program	Continues.	Operation	The relevant instruction will end according to specifications.		
System-defined variables	Variable		Data type		Name	
	_MC_AX[*].MFaultLvl.Active		BOOL		Axis Minor Fault Occurrence	
	_MC_GRP[*].MFaultLvl.Active		BOOL		Axes Group Minor Fault Occurrence	
Cause and correction	Assumed cause		Correction		Prevention	
	An axis instruction was executed when there was already a current instruction and a buffered instruction for the same axis.		Correct the program so that the number of executed instructions does not exceed the buffer limit.		Do not execute an axis instruction when there is already a current instruction and a buffered instruction for the same axis.	
	An axes group instruction was executed when there was already eight current instructions and buffered instructions for the same axis.				Do not execute an axes group instruction when there are already eight current and buffered instructions for the same axis.	
Attached information	<p>Attached Information 1: Error Location</p> <p>Attached Information 2: Error Location Details (Rung Number). For a program section, the rung number from the start of the section is given. For ST, the line number is given.</p> <p>Attached Information 3: Names of the Instruction and Instruction Instance Where the Error Occurred. If there is more than one possible instruction, information is given on all of them. Nothing is given if the instruction cannot be identified.</p> <p>Attached Information 4: Expansion Error Code (<i>ErrorIDEx</i>)</p>					
Precautions/Remarks	If a program is changed after an error occurs, the attached information that is displayed may not be correct.					

Event name	Insufficient Travel Distance		Event code	54015444 hex		
Meaning	The specified motion cannot be executed for the deceleration rate or acceleration rate that was specified for multi-execution or re-execution of a positioning instruction.					
Source	PLC Function Module		Source details	Instruction	Detection timing	At instruction execution
Error attributes	Level	Observation	Recovery	---	Log category	System
Effects	User program	Continues.	Operation	The relevant instruction will end according to specifications.		
System-defined variables	Variable		Data type		Name	
	_MC_AX[*].MFaultLvl.Active		BOOL		Axis Minor Fault Occurrence	
	_MC_GRP[*].MFaultLvl.Active		BOOL		Axes Group Minor Fault Occurrence	
Cause and correction	Assumed cause		Correction		Prevention	
	Stopping at the target position was not possible for the specified acceleration/deceleration rate for multi-execution or re-execution of a positioning instruction when the Acceleration/Deceleration Over parameter was set to generate a minor fault and stop.		Correct the program based on the operating specifications for the instruction so that the target position is not exceeded at the deceleration rate or acceleration rate specified for multi-execution or re-execution of the positioning instruction. Or, change the Acceleration/Deceleration Over parameter to a setting other than to generate a minor fault and stop.		Check the operating specifications for the relevant instruction and write the program so that this error does not occur. Or, change the Acceleration/Deceleration Over parameter to a setting other than to generate a minor fault and stop.	
Attached information	<p>Attached Information 1: Error Location</p> <p>Attached Information 2: Error Location Details (Rung Number). For a program section, the rung number from the start of the section is given. For ST, the line number is given.</p> <p>Attached Information 3: Names of the Instruction and Instruction Instance Where the Error Occurred. If there is more than one possible instruction, information is given on all of them. Nothing is given if the instruction cannot be identified.</p> <p>Attached Information 4: Expansion Error Code (<i>ErrorIDEx</i>)</p>					
Precautions/Remarks	If a program is changed after an error occurs, the attached information that is displayed may not be correct.					

Event name	Insufficient Travel Distance to Achieve Blending Transit Velocity			Event code	54015445 hex	
Meaning	There is not sufficient travel distance to accelerate or decelerate to the transit velocity.					
Source	PLC Function Module		Source details	Instruction	Detection timing	At multi-execution of instructions
Error attributes	Level	Observation	Recovery	---	Log category	System
Effects	User program	Continues.	Operation	The relevant instruction will end according to specifications.		
System-defined variables	Variable		Data type		Name	
	_MC_AX[*].MFaultLvl.Active		BOOL		Axis Minor Fault Occurrence	
	_MC_GRP[*].MFaultLvl.Active		BOOL		Axes Group Minor Fault Occurrence	
Cause and correction	Assumed cause		Correction		Prevention	
	There was not sufficient travel distance to accelerate the current command to the transit velocity when the Acceleration/Deceleration Over parameter was set to generate a minor fault and stop.		Correct the program to allow a sufficient travel distance according to the operating specifications of the instruction. Or, change the Acceleration/Deceleration Over parameter to a setting other than to generate a minor fault and stop.		Check the operating specifications for the relevant instruction and write the program so that this error does not occur. Or, change the Acceleration/Deceleration Over parameter to a setting other than to generate a minor fault and stop.	
Attached information	<p>Attached Information 1: Error Location</p> <p>Attached Information 2: Error Location Details (Rung Number). For a program section, the rung number from the start of the section is given. For ST, the line number is given.</p> <p>Attached Information 3: Names of the Instruction and Instruction Instance Where the Error Occurred. If there is more than one possible instruction, information is given on all of them. Nothing is given if the instruction cannot be identified.</p> <p>Attached Information 4: Expansion Error Code (<i>ErrorIDEx</i>)</p>					
Precautions/Remarks	If a program is changed after an error occurs, the attached information that is displayed may not be correct.					

Event name	Move Link Constant Velocity Insufficient Travel Distance			Event code	54015446 hex	
Meaning	The constant-velocity travel distance of the master axis is less than zero.					
Source	PLC Function Module		Source details	Instruction	Detection timing	At instruction execution
Error attributes	Level	Observation	Recovery	---	Log category	System
Effects	User program	Continues.	Operation	The relevant instruction will end according to specifications.		
System-defined variables	Variable		Data type		Name	
	_MC_AX[*].MFaultLvl.Active		BOOL		Axis Minor Fault Occurrence	
Cause and correction	Assumed cause		Correction		Prevention	
	The constant velocity travel distance of the master axis is below 0 for the MC_MoveLink (Synchronous Positioning) instruction.		Correct the program so that the master distance is greater than or equal to the master distance in acceleration plus the master distance in deceleration.		Check the operating specifications for the relevant instruction and write the program so that this error does not occur.	
Attached information	<p>Attached Information 1: Error Location</p> <p>Attached Information 2: Error Location Details (Rung Number). For a program section, the rung number from the start of the section is given. For ST, the line number is given.</p> <p>Attached Information 3: Names of the Instruction and Instruction Instance Where the Error Occurred. If there is more than one possible instruction, information is given on all of them. Nothing is given if the instruction cannot be identified.</p> <p>Attached Information 4: Expansion Error Code (<i>ErrorIDEx</i>)</p>					
Precautions/Remarks	If a program is changed after an error occurs, the attached information that is displayed may not be correct.					

Event name	Positioning Gear Operation Insufficient Target Velocity		Event code	54015447 hex		
Meaning	For the MC_GearInPos (Positioning Gear Operation) instruction, the target velocity of the slave axis is too small to achieve the required velocity.					
Source	PLC Function Module		Source details	Instruction	Detection timing	At instruction execution
Error attributes	Level	Observation	Recovery	---	Log category	System
Effects	User program	Continues.	Operation	The relevant instruction will end according to specifications.		
System-defined variables	Variable		Data type		Name	
	_MC_AX[*].MFAultLvl.Active		BOOL		Axis Minor Fault Occurrence	
Cause and correction	Assumed cause		Correction		Prevention	
	For the MC_GearInPos (Positioning Gear Operation) instruction, the value of the <i>Velocity</i> (Target Velocity) input variable is smaller than the master axis velocity multiplied by the gear ratio when the instruction was executed.		Set the value of the <i>Velocity</i> (Target Velocity) input variable to a value that is greater than the master axis velocity multiplied by the gear ratio when the instruction is executed based on the operating specifications of the instruction.		Check the operating specifications for the relevant instruction and write the program so that this error does not occur.	
Attached information	<p>Attached Information 1: Error Location</p> <p>Attached Information 2: Error Location Details (Rung Number). For a program section, the rung number from the start of the section is given. For ST, the line number is given.</p> <p>Attached Information 3: Names of the Instruction and Instruction Instance Where the Error Occurred. If there is more than one possible instruction, information is given on all of them. Nothing is given if the instruction cannot be identified.</p> <p>Attached Information 4: Expansion Error Code (<i>ErrorIDEx</i>)</p>					
Precautions/Remarks	If a program is changed after an error occurs, the attached information that is displayed may not be correct.					

Event name	Same Start Point and End Point for Circular Interpolation		Event code	54015448 hex		
Meaning	The start point and end point were the same when the radius method was specified for the MC_MoveCircular2D (Circular 2D Interpolation) instruction. Or, the start point, end point, and border point were the same when the border point method was specified.					
Source	PLC Function Module		Source details	Instruction	Detection timing	At instruction execution
Error attributes	Level	Observation	Recovery	---	Log category	System
Effects	User program	Continues.	Operation	The relevant instruction will end according to specifications.		
System-defined variables	Variable		Data type		Name	
	_MC_GRP[*].MFAultLvl.Active		BOOL		Axes Group Minor Fault Occurrence	
Cause and correction	Assumed cause		Correction		Prevention	
	The start point and end point were the same when the radius method was specified for the MC_MoveCircular2D (Circular 2D Interpolation) instruction.		Correct the program so that the radius specification is not used when the start point and end point for the instruction are the same.		Do not use the same start point and end point when you execute circular interpolation with a radius specification.	
	The start point, end point, and border point were the same when the border point method was specified for the MC_MoveCircular2D (Circular 2D Interpolation) instruction.		Correct the program so that border point specification is not used when the start point, end point, and border point for the instruction are the same.		Do not use the same start point, end point, and border point when you execute circular interpolation with a border point specification.	
Attached information	<p>Attached Information 1: Error Location</p> <p>Attached Information 2: Error Location Details (Rung Number). For a program section, the rung number from the start of the section is given. For ST, the line number is given.</p> <p>Attached Information 3: Names of the Instruction and Instruction Instance Where the Error Occurred. If there is more than one possible instruction, information is given on all of them. Nothing is given if the instruction cannot be identified.</p> <p>Attached Information 4: Expansion Error Code (<i>ErrorIDEx</i>)</p>					
Precautions/Remarks	If a program is changed after an error occurs, the attached information that is displayed may not be correct.					

Event name	Circular Interpolation Center Specification Position Out of Range		Event code	54015449 hex		
Meaning	The position specified for the center point exceeded the allowed range when the center method was specified for the MC_MoveCircular2D (Circular 2D Interpolation) instruction.					
Source	PLC Function Module		Source details	Instruction	Detection timing	At instruction execution
Error attributes	Level	Observation	Recovery	---	Log category	System
Effects	User program	Continues.	Operation	The relevant instruction will end according to specifications.		
System-defined variables	Variable		Data type		Name	
	_MC_GRP[*].MFaultLvl.Active		BOOL		Axes Group Minor Fault Occurrence	
Cause and correction	Assumed cause		Correction		Prevention	
	The difference between the distance from the start point to the center point and the distance between the end point to the center point exceeded the permitted value specified for the correction allowance ratio in the axes group settings when the center designation method was specified for the MC_MoveCircular2D (Circular 2D Interpolation) instruction.		Correct the center point so that the difference between the distance from the start point to the center point input variables and the distance between the end point to the center point input variables is less than the permitted value specified for the correction allowance ratio in the axes group settings.		Correct the difference between the distance from the start point to the center point and the distance between the end point to the center point so that it does not exceed the correction allowance ratio in the axes group settings.	
Attached information	Attached Information 1: Error Location Attached Information 2: Error Location Details (Rung Number). For a program section, the rung number from the start of the section is given. For ST, the line number is given. Attached Information 3: Names of the Instruction and Instruction Instance Where the Error Occurred. If there is more than one possible instruction, information is given on all of them. Nothing is given if the instruction cannot be identified. Attached Information 4: Expansion Error Code (<i>ErrorIDEx</i>)					
Precautions/Remarks	If a program is changed after an error occurs, the attached information that is displayed may not be correct.					

Event name	Instruction Execution Error Caused by Count Mode Setting		Event code	5401544A hex		
Meaning	An instruction that cannot be used when the Count Mode is set to Rotary Mode was executed for an axis that was set to Rotary Mode.					
Source	PLC Function Module		Source details	Instruction	Detection timing	At instruction execution
Error attributes	Level	Observation	Recovery	---	Log category	System
Effects	User program	Continues.	Operation	The relevant instruction will end according to specifications.		
System-defined variables	Variable		Data type		Name	
	_MC_GRP[*].MFaultLvl.Active		BOOL		Axes Group Minor Fault Occurrence	
Cause and correction	Assumed cause		Correction		Prevention	
	An instruction that cannot be used when the Count Mode is set to Rotary Mode was executed for an axis that was set to Rotary Mode.		Change the Count Mode of the relevant axis to Linear Mode.		Confirm the Count Mode in which you can execute the instruction and set the correct Count Mode for the axis.	
Attached information	Attached Information 1: Error Location Attached Information 2: Error Location Details (Rung Number). For a program section, the rung number from the start of the section is given. For ST, the line number is given. Attached Information 3: Names of the Instruction and Instruction Instance Where the Error Occurred. If there is more than one possible instruction, information is given on all of them. Nothing is given if the instruction cannot be identified. Attached Information 4: Expansion Error Code (<i>ErrorIDEx</i>)					
Precautions/Remarks	If a program is changed after an error occurs, the attached information that is displayed may not be correct.					

Event name	Parameter Selection Out of Range			Event code	5401544C hex	
Meaning	The parameter specified for the <i>ParameterNumber</i> input variable to a motion control instruction is out of range.					
Source	PLC Function Module		Source details	Instruction	Detection timing	At instruction execution
Error attributes	Level	Observation	Recovery	---	Log category	System
Effects	User program	Continues.	Operation	The relevant instruction will end according to specifications.		
System-defined variables	Variable		Data type		Name	
	_MC_COM.MFaultLvl.Active		BOOL		MC Common Minor Fault Occurrence	
Cause and correction	Assumed cause		Correction		Prevention	
	Instruction input parameter exceeded the valid range of the input variable.		Correct the parameter so that the valid range of the input variable is not exceeded for the relevant instruction.		Set the input parameter to the instruction so that the valid range of the input variable is not exceeded.	
Attached information	<p>Attached Information 1: Error Location</p> <p>Attached Information 2: Error Location Details (Rung Number). For a program section, the rung number from the start of the section is given. For ST, the line number is given.</p> <p>Attached Information 3: Names of the Instruction and Instruction Instance Where the Error Occurred. If there is more than one possible instruction, information is given on all of them. Nothing is given if the instruction cannot be identified.</p> <p>Attached Information 4: Expansion Error Code (<i>ErrorIDEx</i>)</p>					
Precautions/Remarks	If a program is changed after an error occurs, the attached information that is displayed may not be correct.					

Event name	Stop Method Selection Out of Range			Event code	5401544D hex	
Meaning	The parameter specified for the <i>StopMode</i> input variable to a motion control instruction is out of range.					
Source	PLC Function Module		Source details	Instruction	Detection timing	At instruction execution
Error attributes	Level	Observation	Recovery	---	Log category	System
Effects	User program	Continues.	Operation	The relevant instruction will end according to specifications.		
System-defined variables	Variable		Data type		Name	
	_MC_AX[*].MFaultLvl.Active		BOOL		Axis Minor Fault Occurrence	
Cause and correction	Assumed cause		Correction		Prevention	
	Instruction input parameter exceeded the valid range of the input variable.		Correct the parameter so that the valid range of the input variable is not exceeded for the relevant instruction.		Set the input parameter to the instruction so that the valid range of the input variable is not exceeded.	
Attached information	<p>Attached Information 1: Error Location</p> <p>Attached Information 2: Error Location Details (Rung Number). For a program section, the rung number from the start of the section is given. For ST, the line number is given.</p> <p>Attached Information 3: Names of the Instruction and Instruction Instance Where the Error Occurred. If there is more than one possible instruction, information is given on all of them. Nothing is given if the instruction cannot be identified.</p> <p>Attached Information 4: Expansion Error Code (<i>ErrorIDEx</i>)</p>					
Precautions/Remarks	If a program is changed after an error occurs, the attached information that is displayed may not be correct.					

Event name	Latch ID Selection Out of Range for Trigger Input Condition			Event code	5401544E hex	
Meaning	The parameter specified for the <i>TriggerInput::LatchID</i> input variable to a motion control instruction is out of range.					
Source	PLC Function Module		Source details	Instruction	Detection timing	At instruction execution
Error attributes	Level	Observation	Recovery	---	Log category	System
Effects	User program	Continues.	Operation	The relevant instruction will end according to specifications.		
System-defined variables	Variable		Data type		Name	
	_MC_AX[*].MFaultLvl.Active		BOOL		Axis Minor Fault Occurrence	
Cause and correction	Assumed cause		Correction		Prevention	
	Instruction input parameter exceeded the valid range of the input variable.		Correct the parameter so that the valid range of the input variable is not exceeded for the relevant instruction.		Set the input parameter to the instruction so that the valid range of the input variable is not exceeded.	
Attached information	<p>Attached Information 1: Error Location</p> <p>Attached Information 2: Error Location Details (Rung Number). For a program section, the rung number from the start of the section is given. For ST, the line number is given.</p> <p>Attached Information 3: Names of the Instruction and Instruction Instance Where the Error Occurred. If there is more than one possible instruction, information is given on all of them. Nothing is given if the instruction cannot be identified.</p> <p>Attached Information 4: Expansion Error Code (<i>ErrorIDEx</i>)</p>					
Precautions/Remarks	If a program is changed after an error occurs, the attached information that is displayed may not be correct.					

Event name	Setting Out of Range for Writing MC Setting			Event code	5401544F hex	
Meaning	The parameter specified for the <i>SettingValue</i> input variable to a motion control instruction is out of range.					
Source	PLC Function Module		Source details	Instruction	Detection timing	At instruction execution
Error attributes	Level	Observation	Recovery	---	Log category	System
Effects	User program	Continues.	Operation	The relevant instruction will end according to specifications.		
System-defined variables	Variable		Data type		Name	
	_MC_COM.MFaultLvl.Active		BOOL		MC Common Minor Fault Occurrence	
Cause and correction	Assumed cause		Correction		Prevention	
	Instruction input parameter exceeded the valid range of the input variable.		Correct the parameter so that the valid range of the input variable is not exceeded for the relevant instruction.		Set the input parameter to the instruction so that the valid range of the input variable is not exceeded.	
	The parameter specification and the data type of the setting value do not agree.		Make corrections so that the parameter settings and the data types of the settings agree.		Make sure the parameter settings and the data type of the setting values agree.	
Attached information	<p>Attached Information 1: Error Location</p> <p>Attached Information 2: Error Location Details (Rung Number). For a program section, the rung number from the start of the section is given. For ST, the line number is given.</p> <p>Attached Information 3: Names of the Instruction and Instruction Instance Where the Error Occurred. If there is more than one possible instruction, information is given on all of them. Nothing is given if the instruction cannot be identified.</p> <p>Attached Information 4: Expansion Error Code (<i>ErrorIDEx</i>)</p>					
Precautions/Remarks	If a program is changed after an error occurs, the attached information that is displayed may not be correct.					

Event name	Trigger Input Condition Mode Selection Out of Range		Event code	54015450 hex		
Meaning	The parameter specified for the <i>TriggerInput::Mode</i> input variable to a motion control instruction is out of range.					
Source	PLC Function Module		Source details	Instruction	Detection timing	At instruction execution
Error attributes	Level	Observation	Recovery	---	Log category	System
Effects	User program	Continues.	Operation	The relevant instruction will end according to specifications.		
System-defined variables	Variable		Data type		Name	
	_MC_AX[*].MFaultLvl.Active		BOOL		Axis Minor Fault Occurrence	
Cause and correction	Assumed cause		Correction		Prevention	
	Instruction input parameter exceeded the valid range of the input variable.		Correct the parameter so that the valid range of the input variable is not exceeded for the relevant instruction.		Set the input parameter to the instruction so that the valid range of the input variable is not exceeded.	
Attached information	<p>Attached Information 1: Error Location</p> <p>Attached Information 2: Error Location Details (Rung Number). For a program section, the rung number from the start of the section is given. For ST, the line number is given.</p> <p>Attached Information 3: Names of the Instruction and Instruction Instance Where the Error Occurred. If there is more than one possible instruction, information is given on all of them. Nothing is given if the instruction cannot be identified.</p> <p>Attached Information 4: Expansion Error Code (<i>ErrorIDEx</i>)</p>					
Precautions/Remarks	If a program is changed after an error occurs, the attached information that is displayed may not be correct.					

Event name	Drive Trigger Signal Selection Out of Range for Trigger Input Condition		Event code	54015451 hex		
Meaning	The parameter specified for the <i>TriggerInput::InputDrive</i> input variable to a motion control instruction is out of range.					
Source	PLC Function Module		Source details	Instruction	Detection timing	At instruction execution
Error attributes	Level	Observation	Recovery	---	Log category	System
Effects	User program	Continues.	Operation	The relevant instruction will end according to specifications.		
System-defined variables	Variable		Data type		Name	
	_MC_AX[*].MFaultLvl.Active		BOOL		Axis Minor Fault Occurrence	
Cause and correction	Assumed cause		Correction		Prevention	
	Instruction input parameter exceeded the valid range of the input variable.		Correct the parameter so that the valid range of the input variable is not exceeded for the relevant instruction.		Set the input parameter to the instruction so that the valid range of the input variable is not exceeded.	
Attached information	<p>Attached Information 1: Error Location</p> <p>Attached Information 2: Error Location Details (Rung Number). For a program section, the rung number from the start of the section is given. For ST, the line number is given.</p> <p>Attached Information 3: Names of the Instruction and Instruction Instance Where the Error Occurred. If there is more than one possible instruction, information is given on all of them. Nothing is given if the instruction cannot be identified.</p> <p>Attached Information 4: Expansion Error Code (<i>ErrorIDEx</i>)</p>					
Precautions/Remarks	If a program is changed after an error occurs, the attached information that is displayed may not be correct.					

Event name	Motion Control Instruction Re-execution Disabled (Axis Specification)		Event code	54015453 hex		
Meaning	An attempt was made to change the parameter for the <i>Axis</i> input variable when re-executing a motion control instruction. (This input variable cannot be changed when re-executing an instruction.)					
Source	PLC Function Module		Source details	Instruction	Detection timing	At instruction re-execution
Error attributes	Level	Observation	Recovery	---	Log category	System
Effects	User program	Continues.	Operation	The relevant instruction will end according to specifications.		
System-defined variables	Variable		Data type		Name	
	_MC_AX[*].MFAultLvl.Active		BOOL		Axis Minor Fault Occurrence	
Cause and correction	Assumed cause		Correction		Prevention	
	A parameter for an input variable that cannot be changed for re-execution was changed.		Correct the program so that the parameter for the relevant input variable does not change when the relevant instruction is re-executed.		Check the manual to see if the input variables to the relevant motion control instruction can be changed by re-execution. Write the program so that the input parameters for any input variable that cannot be changed do not change upon re-execution.	
Attached information	<p>Attached Information 1: Error Location</p> <p>Attached Information 2: Error Location Details (Rung Number). For a program section, the rung number from the start of the section is given. For ST, the line number is given.</p> <p>Attached Information 3: Names of the Instruction and Instruction Instance Where the Error Occurred. If there is more than one possible instruction, information is given on all of them. Nothing is given if the instruction cannot be identified.</p> <p>Attached Information 4: Expansion Error Code (<i>ErrorIDEx</i>)</p>					
Precautions/Remarks	If a program is changed after an error occurs, the attached information that is displayed may not be correct.					

Event name	Motion Control Instruction Re-execution Disabled (Buffer Mode Selection)		Event code	54015454 hex		
Meaning	An attempt was made to change the parameter for the <i>BufferMode</i> input variable when re-executing a motion control instruction. (This input variable cannot be changed when re-executing an instruction.)					
Source	PLC Function Module		Source details	Instruction	Detection timing	At instruction re-execution
Error attributes	Level	Observation	Recovery	---	Log category	System
Effects	User program	Continues.	Operation	The relevant instruction will end according to specifications.		
System-defined variables	Variable		Data type		Name	
	_MC_AX[*].MFAultLvl.Active		BOOL		Axis Minor Fault Occurrence	
	_MC_GRP[*].MFAultLvl.Active		BOOL		Axes Group Minor Fault Occurrence	
Cause and correction	Assumed cause		Correction		Prevention	
	A parameter for an input variable that cannot be changed for re-execution was changed.		Correct the program so that the parameter for the relevant input variable does not change when the relevant instruction is re-executed.		Check the manual to see if the input variables to the relevant motion control instruction can be changed by re-execution. Write the program so that the input parameters for any input variable that cannot be changed do not change upon re-execution.	
Attached information	<p>Attached Information 1: Error Location</p> <p>Attached Information 2: Error Location Details (Rung Number). For a program section, the rung number from the start of the section is given. For ST, the line number is given.</p> <p>Attached Information 3: Names of the Instruction and Instruction Instance Where the Error Occurred. If there is more than one possible instruction, information is given on all of them. Nothing is given if the instruction cannot be identified.</p> <p>Attached Information 4: Expansion Error Code (<i>ErrorIDEx</i>)</p>					
Precautions/Remarks	If a program is changed after an error occurs, the attached information that is displayed may not be correct.					

Event name	Motion Control Instruction Re-execution Disabled (Direction Selection)		Event code	54015455 hex		
Meaning	An attempt was made to change the parameter for the <i>Direction</i> input variable when re-executing a motion control instruction. (This input variable cannot be changed when re-executing an instruction.)					
Source	PLC Function Module		Source details	Instruction	Detection timing	At instruction re-execution
Error attributes	Level	Observation	Recovery	---	Log category	System
Effects	User program	Continues.	Operation	The relevant instruction will end according to specifications.		
System-defined variables	Variable		Data type		Name	
	_MC_AX[*].MFaultLvl.Active		BOOL		Axis Minor Fault Occurrence	
Cause and correction	Assumed cause		Correction		Prevention	
	An input variable that cannot be changed for re-execution was changed.		Correct the program so that the parameter for the relevant input variable does not change when the relevant instruction is re-executed.		Check the manual to see if the input variables to the relevant motion control instruction can be changed by re-execution. Write the program so that the input parameters for any input variable that cannot be changed do not change upon re-execution.	
Attached information	<p>Attached Information 1: Error Location</p> <p>Attached Information 2: Error Location Details (Rung Number). For a program section, the rung number from the start of the section is given. For ST, the line number is given.</p> <p>Attached Information 3: Names of the Instruction and Instruction Instance Where the Error Occurred. If there is more than one possible instruction, information is given on all of them. Nothing is given if the instruction cannot be identified.</p> <p>Attached Information 4: Expansion Error Code (<i>ErrorIDEx</i>)</p>					
Precautions/Remarks	If a program is changed after an error occurs, the attached information that is displayed may not be correct.					

Event name	Motion Control Instruction Re-execution Disabled (Execution Mode)		Event code	54015456 hex		
Meaning	An attempt was made to change the parameter for the <i>Periodic</i> input variable when re-executing a motion control instruction. (This input variable cannot be changed when re-executing an instruction.)					
Source	PLC Function Module		Source details	Instruction	Detection timing	At instruction re-execution
Error attributes	Level	Observation	Recovery	---	Log category	System
Effects	User program	Continues.	Operation	The relevant instruction will end according to specifications.		
System-defined variables	Variable		Data type		Name	
	_MC_AX[*].MFaultLvl.Active		BOOL		Axis Minor Fault Occurrence	
Cause and correction	Assumed cause		Correction		Prevention	
	A parameter for an input variable that cannot be changed for re-execution was changed.		Correct the program so that the parameter for the relevant input variable does not change when the relevant instruction is re-executed.		Check the manual to see if the input variables to the relevant motion control instruction can be changed by re-execution. Write the program so that the input parameters for any input variable that cannot be changed do not change upon re-execution.	
Attached information	<p>Attached Information 1: Error Location</p> <p>Attached Information 2: Error Location Details (Rung Number). For a program section, the rung number from the start of the section is given. For ST, the line number is given.</p> <p>Attached Information 3: Names of the Instruction and Instruction Instance Where the Error Occurred. If there is more than one possible instruction, information is given on all of them. Nothing is given if the instruction cannot be identified.</p> <p>Attached Information 4: Expansion Error Code (<i>ErrorIDEx</i>)</p>					
Precautions/Remarks	If a program is changed after an error occurs, the attached information that is displayed may not be correct.					

Event name	Motion Control Instruction Re-execution Disabled (Axes Group Specification)		Event code	54015457 hex		
Meaning	An attempt was made to change the parameter for the <i>AxesGroup</i> input variable when re-executing a motion control instruction. (This input variable cannot be changed when re-executing an instruction.)					
Source	PLC Function Module		Source details	Instruction	Detection timing	At instruction re-execution
Error attributes	Level	Observation	Recovery	---	Log category	System
Effects	User program	Continues.	Operation	The relevant instruction will end according to specifications.		
System-defined variables	Variable		Data type		Name	
	_MC_GRP[*].MFaultLvl.Active		BOOL		Axes Group Minor Fault Occurrence	
Cause and correction	Assumed cause		Correction		Prevention	
	A parameter for an input variable that cannot be changed for re-execution was changed.		Correct the program so that the parameter for the relevant input variable does not change when the relevant instruction is re-executed.		Check the manual to see if the input variables to the relevant motion control instruction can be changed by re-execution. Write the program so that the input parameters for any input variable that cannot be changed do not change upon re-execution.	
Attached information	<p>Attached Information 1: Error Location</p> <p>Attached Information 2: Error Location Details (Rung Number). For a program section, the rung number from the start of the section is given. For ST, the line number is given.</p> <p>Attached Information 3: Names of the Instruction and Instruction Instance Where the Error Occurred. If there is more than one possible instruction, information is given on all of them. Nothing is given if the instruction cannot be identified.</p> <p>Attached Information 4: Expansion Error Code (<i>ErrorIDEx</i>)</p>					
Precautions/Remarks	If a program is changed after an error occurs, the attached information that is displayed may not be correct.					

Event name	Motion Control Instruction Re-execution Disabled (Jerk Setting)		Event code	54015458 hex		
Meaning	An attempt was made to change the parameter for the <i>Jerk</i> input variable when re-executing a motion control instruction. (This input variable cannot be changed when re-executing an instruction.)					
Source	PLC Function Module		Source details	Instruction	Detection timing	At instruction re-execution
Error attributes	Level	Observation	Recovery	---	Log category	System
Effects	User program	Continues.	Operation	The relevant instruction will end according to specifications.		
System-defined variables	Variable		Data type		Name	
	_MC_AX[*].MFaultLvl.Active		BOOL		Axis Minor Fault Occurrence	
	_MC_GRP[*].MFaultLvl.Active		BOOL		Axes Group Minor Fault Occurrence	
Cause and correction	Assumed cause		Correction		Prevention	
	A parameter for an input variable that cannot be changed for re-execution was changed.		Correct the program so that the parameter for the relevant input variable does not change when the relevant instruction is re-executed.		Check the manual to see if the input variables to the relevant motion control instruction can be changed by re-execution. Write the program so that the input parameters for any input variable that cannot be changed do not change upon re-execution.	
Attached information	<p>Attached Information 1: Error Location</p> <p>Attached Information 2: Error Location Details (Rung Number). For a program section, the rung number from the start of the section is given. For ST, the line number is given.</p> <p>Attached Information 3: Names of the Instruction and Instruction Instance Where the Error Occurred. If there is more than one possible instruction, information is given on all of them. Nothing is given if the instruction cannot be identified.</p> <p>Attached Information 4: Expansion Error Code (<i>ErrorIDEx</i>)</p>					
Precautions/Remarks	If a program is changed after an error occurs, the attached information that is displayed may not be correct.					

Event name	Motion Control Instruction Re-execution Disabled (Master Axis)		Event code	54015459 hex		
Meaning	An attempt was made to change the parameter for the <i>Master</i> input variable when re-executing a motion control instruction. (This input variable cannot be changed when re-executing an instruction.)					
Source	PLC Function Module		Source details	Instruction	Detection timing	At instruction re-execution
Error attributes	Level	Observation	Recovery	---	Log category	System
Effects	User program	Continues.	Operation	The relevant instruction will end according to specifications.		
System-defined variables	Variable		Data type		Name	
	_MC_AX[*].MFAultLvl.Active		BOOL		Axis Minor Fault Occurrence	
Cause and correction	Assumed cause		Correction		Prevention	
	A parameter for an input variable that cannot be changed for re-execution was changed.		Correct the program so that the parameter for the relevant input variable does not change when the relevant instruction is re-executed.		Check the manual to see if the input variables to the relevant motion control instruction can be changed by re-execution. Write the program so that the input parameters for any input variable that cannot be changed do not change upon re-execution.	
Attached information	<p>Attached Information 1: Error Location</p> <p>Attached Information 2: Error Location Details (Rung Number). For a program section, the rung number from the start of the section is given. For ST, the line number is given.</p> <p>Attached Information 3: Names of the Instruction and Instruction Instance Where the Error Occurred. If there is more than one possible instruction, information is given on all of them. Nothing is given if the instruction cannot be identified.</p> <p>Attached Information 4: Expansion Error Code (<i>ErrorIDEx</i>)</p>					
Precautions/Remarks	If a program is changed after an error occurs, the attached information that is displayed may not be correct.					

Event name	Motion Control Instruction Re-execution Disabled (MasterOffset)		Event code	5401545A hex		
Meaning	An attempt was made to change the parameter for the <i>MasterOffset</i> input variable when re-executing a motion control instruction. (This input variable cannot be changed when re-executing an instruction.)					
Source	PLC Function Module		Source details	Instruction	Detection timing	At instruction re-execution
Error attributes	Level	Observation	Recovery	---	Log category	System
Effects	User program	Continues.	Operation	The relevant instruction will end according to specifications.		
System-defined variables	Variable		Data type		Name	
	_MC_AX[*].MFAultLvl.Active		BOOL		Axis Minor Fault Occurrence	
Cause and correction	Assumed cause		Correction		Prevention	
	A parameter for an input variable that cannot be changed for re-execution was changed.		Correct the program so that the parameter for the relevant input variable does not change when the relevant instruction is re-executed.		Check the manual to see if the input variables to the relevant motion control instruction can be changed by re-execution. Write the program so that the input parameters for any input variable that cannot be changed do not change upon re-execution.	
Attached information	<p>Attached Information 1: Error Location</p> <p>Attached Information 2: Error Location Details (Rung Number). For a program section, the rung number from the start of the section is given. For ST, the line number is given.</p> <p>Attached Information 3: Names of the Instruction and Instruction Instance Where the Error Occurred. If there is more than one possible instruction, information is given on all of them. Nothing is given if the instruction cannot be identified.</p> <p>Attached Information 4: Expansion Error Code (<i>ErrorIDEx</i>)</p>					
Precautions/Remarks	If a program is changed after an error occurs, the attached information that is displayed may not be correct.					

Event name	Motion Control Instruction Re-execution Disabled (MasterScaling)		Event code	5401545B hex		
Meaning	An attempt was made to change the parameter for the <i>MasterScaling</i> input variable when re-executing a motion control instruction. (This input variable cannot be changed when re-executing an instruction.)					
Source	PLC Function Module		Source details	Instruction	Detection timing	At instruction re-execution
Error attributes	Level	Observation	Recovery	---	Log category	System
Effects	User program	Continues.	Operation	The relevant instruction will end according to specifications.		
System-defined variables	Variable		Data type		Name	
	_MC_AX[*].MFAultLvl.Active		BOOL		Axis Minor Fault Occurrence	
Cause and correction	Assumed cause		Correction		Prevention	
	A parameter for an input variable that cannot be changed for re-execution was changed.		Correct the program so that the parameter for the relevant input variable does not change when the relevant instruction is re-executed.		Check the manual to see if the input variables to the relevant motion control instruction can be changed by re-execution. Write the program so that the input parameters for any input variable that cannot be changed do not change upon re-execution.	
Attached information	<p>Attached Information 1: Error Location</p> <p>Attached Information 2: Error Location Details (Rung Number). For a program section, the rung number from the start of the section is given. For ST, the line number is given.</p> <p>Attached Information 3: Names of the Instruction and Instruction Instance Where the Error Occurred. If there is more than one possible instruction, information is given on all of them. Nothing is given if the instruction cannot be identified.</p> <p>Attached Information 4: Expansion Error Code (<i>ErrorIDEx</i>)</p>					
Precautions/Remarks	If a program is changed after an error occurs, the attached information that is displayed may not be correct.					

Event name	Motion Control Instruction Re-execution Disabled (MasterStartDistance)		Event code	5401545C hex		
Meaning	An attempt was made to change the parameter for the <i>MasterStartDistance</i> input variable when re-executing a motion control instruction. (This input variable cannot be changed when re-executing an instruction.)					
Source	PLC Function Module		Source details	Instruction	Detection timing	At instruction re-execution
Error attributes	Level	Observation	Recovery	---	Log category	System
Effects	User program	Continues.	Operation	The relevant instruction will end according to specifications.		
System-defined variables	Variable		Data type		Name	
	_MC_AX[*].MFAultLvl.Active		BOOL		Axis Minor Fault Occurrence	
Cause and correction	Assumed cause		Correction		Prevention	
	A parameter for an input variable that cannot be changed for re-execution was changed.		Correct the program so that the parameter for the relevant input variable does not change when the relevant instruction is re-executed.		Check the manual to see if the input variables to the relevant motion control instruction can be changed by re-execution. Write the program so that the input parameters for any input variable that cannot be changed do not change upon re-execution.	
Attached information	<p>Attached Information 1: Error Location</p> <p>Attached Information 2: Error Location Details (Rung Number). For a program section, the rung number from the start of the section is given. For ST, the line number is given.</p> <p>Attached Information 3: Names of the Instruction and Instruction Instance Where the Error Occurred. If there is more than one possible instruction, information is given on all of them. Nothing is given if the instruction cannot be identified.</p> <p>Attached Information 4: Expansion Error Code (<i>ErrorIDEx</i>)</p>					
Precautions/Remarks	If a program is changed after an error occurs, the attached information that is displayed may not be correct.					

Event name	Motion Control Instruction Re-execution Disabled (Continuous)		Event code	5401545D hex		
Meaning	An attempt was made to change the parameter for the <i>Continuous</i> input variable when re-executing a motion control instruction. (This input variable cannot be changed when re-executing an instruction.)					
Source	PLC Function Module		Source details	Instruction	Detection timing	At instruction re-execution
Error attributes	Level	Observation	Recovery	---	Log category	System
Effects	User program	Continues.	Operation	The relevant instruction will end according to specifications.		
System-defined variables	Variable		Data type		Name	
	_MC_AX[*].MFaultLvl.Active		BOOL		Axis Minor Fault Occurrence	
Cause and correction	Assumed cause		Correction		Prevention	
	A parameter for an input variable that cannot be changed for re-execution was changed.		Correct the program so that the parameter for the relevant input variable does not change when the relevant instruction is re-executed.		Check the manual to see if the input variables to the relevant motion control instruction can be changed by re-execution. Write the program so that the input parameters for any input variable that cannot be changed do not change upon re-execution.	
Attached information	<p>Attached Information 1: Error Location</p> <p>Attached Information 2: Error Location Details (Rung Number). For a program section, the rung number from the start of the section is given. For ST, the line number is given.</p> <p>Attached Information 3: Names of the Instruction and Instruction Instance Where the Error Occurred. If there is more than one possible instruction, information is given on all of them. Nothing is given if the instruction cannot be identified.</p> <p>Attached Information 4: Expansion Error Code (<i>ErrorIDEx</i>)</p>					
Precautions/Remarks	If a program is changed after an error occurs, the attached information that is displayed may not be correct.					

Event name	Motion Control Instruction Re-execution Disabled (MoveMode)		Event code	5401545E hex		
Meaning	An attempt was made to change the parameter for the <i>MoveMode</i> input variable when re-executing a motion control instruction. (This input variable cannot be changed when re-executing an instruction.)					
Source	PLC Function Module		Source details	Instruction	Detection timing	At instruction re-execution
Error attributes	Level	Observation	Recovery	---	Log category	System
Effects	User program	Continues.	Operation	The relevant instruction will end according to specifications.		
System-defined variables	Variable		Data type		Name	
	_MC_AX[*].MFaultLvl.Active		BOOL		Axis Minor Fault Occurrence	
Cause and correction	Assumed cause		Correction		Prevention	
	A parameter for an input variable that cannot be changed for re-execution was changed.		Correct the program so that the parameter for the relevant input variable does not change when the relevant instruction is re-executed.		Check the manual to see if the input variables to the relevant motion control instruction can be changed by re-execution. Write the program so that the input parameters for any input variable that cannot be changed do not change upon re-execution.	
Attached information	<p>Attached Information 1: Error Location</p> <p>Attached Information 2: Error Location Details (Rung Number). For a program section, the rung number from the start of the section is given. For ST, the line number is given.</p> <p>Attached Information 3: Names of the Instruction and Instruction Instance Where the Error Occurred. If there is more than one possible instruction, information is given on all of them. Nothing is given if the instruction cannot be identified.</p> <p>Attached Information 4: Expansion Error Code (<i>ErrorIDEx</i>)</p>					
Precautions/Remarks	If a program is changed after an error occurs, the attached information that is displayed may not be correct.					

Event name	Illegal Auxiliary Axis Specification			Event code	5401545F hex	
Meaning	The axis specified for the <i>Auxiliary</i> input variable to a motion control instruction does not exist.					
Source	PLC Function Module		Source details	Instruction	Detection timing	At instruction execution
Error attributes	Level	Observation	Recovery	---	Log category	System
Effects	User program	Continues.	Operation	The relevant instruction will end according to specifications.		
System-defined variables	Variable		Data type		Name	
	_MC_AX[*].MFaultLvl.Active		BOOL		Axis Minor Fault Occurrence	
Cause and correction	Assumed cause		Correction		Prevention	
	An axis does not exist for the variable specified for the <i>Auxiliary</i> input variable to the instruction.		Correct the instruction so that the variable exists for the axis that was specified for the instruction.		Make sure to specify variables that exist when specifying variables for the input parameters to an instruction.	
Attached information	<p>Attached Information 1: Error Location</p> <p>Attached Information 2: Error Location Details (Rung Number). For a program section, the rung number from the start of the section is given. For ST, the line number is given.</p> <p>Attached Information 3: Names of the Instruction and Instruction Instance Where the Error Occurred. If there is more than one possible instruction, information is given on all of them. Nothing is given if the instruction cannot be identified.</p> <p>Attached Information 4: Expansion Error Code (<i>ErrorIDEx</i>)</p>					
Precautions/Remarks	If a program is changed after an error occurs, the attached information that is displayed may not be correct.					

Event name	Illegal Axis Specification			Event code	54015460 hex	
Meaning	The axis specified for the <i>Axis</i> input variable to a motion control instruction does not exist.					
Source	PLC Function Module		Source details	Instruction	Detection timing	At instruction execution
Error attributes	Level	Observation	Recovery	---	Log category	System
Effects	User program	Continues.	Operation	The relevant instruction will end according to specifications.		
System-defined variables	Variable		Data type		Name	
	_MC_COM.MFaultLvl.Active		BOOL		MC Common Minor Fault Occurrence	
Cause and correction	Assumed cause		Correction		Prevention	
	An axis does not exist for the variable specified for the <i>Axis</i> input variable to the instruction.		Correct the instruction so that the variable exists for the axis that was specified for the instruction.		Make sure to specify a variable that exists when specifying a variable for an input parameter to an instruction.	
Attached information	<p>Attached Information 1: Error Location</p> <p>Attached Information 2: Error Location Details (Rung Number). For a program section, the rung number from the start of the section is given. For ST, the line number is given.</p> <p>Attached Information 3: Names of the Instruction and Instruction Instance Where the Error Occurred. If there is more than one possible instruction, information is given on all of them. Nothing is given if the instruction cannot be identified.</p> <p>Attached Information 4: Expansion Error Code (<i>ErrorIDEx</i>)</p>					
Precautions/Remarks	If a program is changed after an error occurs, the attached information that is displayed may not be correct.					

Event name	Illegal Axes Group Specification		Event code	54015461 hex		
Meaning	The axes group specified for the <i>AxesGroup</i> input variable to a motion control instruction does not exist or is not a used group.					
Source	PLC Function Module		Source details	Instruction	Detection timing	At instruction execution
Error attributes	Level	Observation	Recovery	---	Log category	System
Effects	User program	Continues.	Operation	The relevant instruction will end according to specifications.		
System-defined variables	Variable		Data type		Name	
	_MC_COM.MFaultLvl.Active		BOOL		MC Common Minor Fault Occurrence	
Cause and correction	Assumed cause		Correction		Prevention	
	An axes group does not exist for the variable specified for the <i>AxesGroup</i> input variable to the instruction.		Correct the specification for the instruction so that the specified axes group exists.		Specify a variable that exists when specifying a variable for an input parameter to an instruction.	
	The axes group specified for the <i>AxesGroup</i> input variable to the instruction is not specified as a used group.		Correct the axes group specified by the instruction to a used group.		Set a used axes group for the <i>AxesGroup</i> input variable to the instruction.	
Attached information	<p>Attached Information 1: Error Location</p> <p>Attached Information 2: Error Location Details (Rung Number). For a program section, the rung number from the start of the section is given. For ST, the line number is given.</p> <p>Attached Information 3: Names of the Instruction and Instruction Instance Where the Error Occurred. If there is more than one possible instruction, information is given on all of them. Nothing is given if the instruction cannot be identified.</p> <p>Attached Information 4: Expansion Error Code (<i>ErrorIDEx</i>)</p>					
Precautions/Remarks	If a program is changed after an error occurs, the attached information that is displayed may not be correct.					

Event name	Illegal Master Axis Specification			Event code	5401 5462 hex	
Meaning	The axis that is specified for the <i>Master</i> input variable to a motion control instruction is not correct.					
Source	PLC Function Module		Source details	Instruction	Detection timing	At instruction execution
Error attributes	Level	Observation	Recovery	---	Log category	System
Effects	User program	Continues.	Operation	The relevant instruction will end according to specifications.		
System-defined variables	Variable		Data type		Name	
	_MC_COM.MFaultLvl.Active		BOOL		MC Common Minor Fault Occurrence	
	_MC_AX[*].MFaultLvl.Active		BOOL		Axis Minor Fault Occurrence	
Cause and correction	Assumed cause		Correction		Prevention	
	An axis does not exist for the variable specified for the <i>Master</i> input variable to the instruction.		Correct the instruction so that the variable exists for the axis that was specified for the instruction.		Specify a variable that exists when specifying a variable for an input parameter to an instruction.	
	The axis that was specified for the <i>Master</i> input variable to the MC_Phasing (Shift Master Axis Phase) instruction is not the master axis for syncing.		Correct the variable that is input to the <i>Master</i> input variable of the MC_Phasing (Shift Master Axis Phase) instruction to the axis variable that is specified as the master axis of the synchronized control instruction.		Set the variable that is input to the <i>Master</i> input variable of the MC_Phasing (Shift Master Axis Phase) instruction to the axis variable that is specified as the master axis of the synchronized control instruction.	
	The master axis and a slave axis are not assigned to the same task.		Assign the axes that are input to the <i>Master</i> and <i>Slave</i> input variables to the instruction to the same task.		Specify axes that are assigned to the same tasks for the master and slave axes.	
Attached information	<p>Attached Information 1: Error Location</p> <p>Attached Information 2: Error Location Details (Rung Number). For a program section, the rung number from the start of the section is given. For ST, the line number is given.</p> <p>Attached Information 3: Names of the Instruction and Instruction Instance Where the Error Occurred. If there is more than one possible instruction, information is given on all of them. Nothing is given if the instruction cannot be identified.</p> <p>Attached Information 4: Expansion Error Code (<i>ErrorIDEx</i>)</p>					
Precautions/Remarks	If a program is changed after an error occurs, the attached information that is displayed may not be correct.					

Event name	Motion Control Instruction Re-execution Disabled (Slave-Offset)		Event code	54015463 hex		
Meaning	An attempt was made to change the <i>SlaveOffset</i> input variable when re-executing a motion control instruction. (This input variable cannot be changed when re-executing an instruction.)					
Source	PLC Function Module		Source details	Instruction	Detection timing	At instruction re-execution
Error attributes	Level	Observation	Recovery	---	Log category	System
Effects	User program	Continues.	Operation	The relevant instruction will end according to specifications.		
System-defined variables	Variable		Data type		Name	
	_MC_AX[*].MFAultLvl.Active		BOOL		Axis Minor Fault Occurrence	
Cause and correction	Assumed cause		Correction		Prevention	
	A parameter for an input variable that cannot be changed for re-execution was changed.		Correct the program so that the parameter for the relevant input variable does not change when the relevant instruction is re-executed.		Check the manual to see if the input variables to the relevant motion control instruction can be changed by re-execution. Write the program so that the input parameters for any input variable that cannot be changed do not change upon re-execution.	
Attached information	<p>Attached Information 1: Error Location</p> <p>Attached Information 2: Error Location Details (Rung Number). For a program section, the rung number from the start of the section is given. For ST, the line number is given.</p> <p>Attached Information 3: Names of the Instruction and Instruction Instance Where the Error Occurred. If there is more than one possible instruction, information is given on all of them. Nothing is given if the instruction cannot be identified.</p> <p>Attached Information 4: Expansion Error Code (<i>ErrorIDEx</i>)</p>					
Precautions/Remarks	If a program is changed after an error occurs, the attached information that is displayed may not be correct.					

Event name	Motion Control Instruction Re-execution Disabled (SlaveScaling)		Event code	54015464 hex		
Meaning	An attempt was made to change the <i>SlaveScaling</i> input variable when re-executing a motion control instruction. (This input variable cannot be changed when re-executing an instruction.)					
Source	PLC Function Module		Source details	Instruction	Detection timing	At instruction re-execution
Error attributes	Level	Observation	Recovery	---	Log category	System
Effects	User program	Continues.	Operation	The relevant instruction will end according to specifications.		
System-defined variables	Variable		Data type		Name	
	_MC_AX[*].MFAultLvl.Active		BOOL		Axis Minor Fault Occurrence	
Cause and correction	Assumed cause		Correction		Prevention	
	A parameter for an input variable that cannot be changed for re-execution was changed.		Correct the program so that the parameter for the relevant input variable does not change when the relevant instruction is re-executed.		Check the manual to see if the input variables to the relevant motion control instruction can be changed by re-execution. Write the program so that the input parameters for any input variable that cannot be changed do not change upon re-execution.	
Attached information	<p>Attached Information 1: Error Location</p> <p>Attached Information 2: Error Location Details (Rung Number). For a program section, the rung number from the start of the section is given. For ST, the line number is given.</p> <p>Attached Information 3: Names of the Instruction and Instruction Instance Where the Error Occurred. If there is more than one possible instruction, information is given on all of them. Nothing is given if the instruction cannot be identified.</p> <p>Attached Information 4: Expansion Error Code (<i>ErrorIDEx</i>)</p>					
Precautions/Remarks	If a program is changed after an error occurs, the attached information that is displayed may not be correct.					

Event name	Motion Control Instruction Re-execution Disabled (Start-Position)		Event code	5401 5465 hex		
Meaning	An attempt was made to change the <i>StartPosition</i> input variable when re-executing a motion control instruction. (This input variable cannot be changed when re-executing an instruction.)					
Source	PLC Function Module		Source details	Instruction	Detection timing	At instruction re-execution
Error attributes	Level	Observation	Recovery	---	Log category	System
Effects	User program	Continues.	Operation	The relevant instruction will end according to specifications.		
System-defined variables	Variable		Data type		Name	
	_MC_AX[*].MFaultLvl.Active		BOOL		Axis Minor Fault Occurrence	
Cause and correction	Assumed cause		Correction		Prevention	
	A parameter for an input variable that cannot be changed for re-execution was changed.		Correct the program so that the parameter for the relevant input variable does not change when the relevant instruction is re-executed.		Check the manual to see if the input variables to the relevant motion control instruction can be changed by re-execution. Write the program so that the input parameters for any input variable that cannot be changed do not change upon re-execution.	
Attached information	<p>Attached Information 1: Error Location</p> <p>Attached Information 2: Error Location Details (Rung Number). For a program section, the rung number from the start of the section is given. For ST, the line number is given.</p> <p>Attached Information 3: Names of the Instruction and Instruction Instance Where the Error Occurred. If there is more than one possible instruction, information is given on all of them. Nothing is given if the instruction cannot be identified.</p> <p>Attached Information 4: Expansion Error Code (<i>ErrorIDEx</i>)</p>					
Precautions/Remarks	If a program is changed after an error occurs, the attached information that is displayed may not be correct.					

Event name	Instruction Execution Error with Undefined Home		Event code	54015466 hex		
Meaning	High-speed homing or an interpolation instruction was executed when home was undefined.					
Source	PLC Function Module		Source details	Instruction	Detection timing	At instruction execution
Error attributes	Level	Observation	Recovery	---	Log category	System
Effects	User program	Continues.	Operation	The relevant instruction will end according to specifications.		
System-defined variables	Variable		Data type		Name	
	_MC_AX[*].MFaultLvl.Active		BOOL		Axis Minor Fault Occurrence	
	_MC_GRP[*].MFaultLvl.Active		BOOL		Axes Group Minor Fault Occurrence	
Cause and correction	Assumed cause		Correction		Prevention	
	High-speed homing was executed when home was undefined.		Execute the high-speed homing operation only after homing to define home.		Execute the high-speed homing instruction only after home is defined by homing.	
	An interpolation instruction was executed for an axes group that includes an axis with no defined home.		Perform homing to define home for all axes in the axes group before executing the interpolation instruction.		Perform homing to define home for all axes in the axes group before executing the interpolation instruction.	
	One of the following robot instructions was executed for an axes group that includes a logical axis with no defined home. <ul style="list-style-type: none"> • MC_SetKinTransform • MC_MoveTimeAbsolute • MC_SyncLinearConveyor • MC_SyncOut • MC_GroupMon • MC_RobotJog 					
Attached information	<p>Attached Information 1: Error Location</p> <p>Attached Information 2: Error Location Details (Rung Number). For a program section, the rung number from the start of the section is given. For ST, the line number is given.</p> <p>Attached Information 3: Names of the Instruction and Instruction Instance Where the Error Occurred. If there is more than one possible instruction, information is given on all of them. Nothing is given if the instruction cannot be identified.</p> <p>Attached Information 4: Expansion Error Code (<i>ErrorIDEx</i>)</p>					
Precautions/Remarks	<ul style="list-style-type: none"> • If a program is changed after an error occurs, the attached information that is displayed may not be correct. • If you execute the Set Position instruction after performing homing, home will again be undefined. You must perform homing again to define home in this case. 					

Event name	Motion Control Instruction Re-execution Disabled (Position Type)		Event code	5401 5467 hex		
Meaning	An attempt was made to change the <i>ReferenceType</i> input variable when re-executing a motion control instruction. (This input variable cannot be changed when re-executing an instruction.)					
Source	PLC Function Module		Source details	Instruction	Detection timing	At instruction re-execution
Error attributes	Level	Observation	Recovery	---	Log category	System
Effects	User program	Continues.	Operation	The relevant instruction will end according to specifications.		
System-defined variables	Variable		Data type		Name	
	_MC_AX[*].MFAultLvl.Active		BOOL		Axis Minor Fault Occurrence	
Cause and correction	Assumed cause		Correction		Prevention	
	A parameter for an input variable that cannot be changed for re-execution was changed.		Correct the program so that the parameter for the relevant input variable does not change when the relevant instruction is re-executed.		Check the manual to see if the input variables to the relevant motion control instruction can be changed by re-execution. Write the program so that the input parameters for any input variable that cannot be changed do not change upon re-execution.	
Attached information	<p>Attached Information 1: Error Location</p> <p>Attached Information 2: Error Location Details (Rung Number). For a program section, the rung number from the start of the section is given. For ST, the line number is given.</p> <p>Attached Information 3: Names of the Instruction and Instruction Instance Where the Error Occurred. If there is more than one possible instruction, information is given on all of them. Nothing is given if the instruction cannot be identified.</p> <p>Attached Information 4: Expansion Error Code (<i>ErrorIDEx</i>)</p>					
Precautions/Remarks	If a program is changed after an error occurs, the attached information that is displayed may not be correct.					

Event name	Unused Axis Specification for Master Axis		Event code	5401 5468 hex		
Meaning	The master axis specified for a motion control instruction is an unused axis.					
Source	PLC Function Module		Source details	Instruction	Detection timing	At instruction execution
Error attributes	Level	Observation	Recovery	---	Log category	System
Effects	User program	Continues.	Operation	The relevant instruction will end according to specifications.		
System-defined variables	Variable		Data type		Name	
	_MC_AX[*].MFAultLvl.Active		BOOL		Axis Minor Fault Occurrence	
Cause and correction	Assumed cause		Correction		Prevention	
	The master axis specified for a motion control instruction is an unused axis.		Set a used axis for the master axis that is specified for the instruction.		Make sure the master axis specified for the motion control instruction is a used axis.	
Attached information	<p>Attached Information 1: Error Location</p> <p>Attached Information 2: Error Location Details (Rung Number). For a program section, the rung number from the start of the section is given. For ST, the line number is given.</p> <p>Attached Information 3: Names of the Instruction and Instruction Instance Where the Error Occurred. If there is more than one possible instruction, information is given on all of them. Nothing is given if the instruction cannot be identified.</p> <p>Attached Information 4: Expansion Error Code (<i>ErrorIDEx</i>)</p>					
Precautions/Remarks	If a program is changed after an error occurs, the attached information that is displayed may not be correct.					

Event name	First Position Setting Out of Range			Event code	54015469 hex	
Meaning	The parameter specified for the <i>FirstPosition</i> input variable to a motion control instruction is out of range.					
Source	PLC Function Module		Source details	Instruction	Detection timing	At instruction execution
Error attributes	Level	Observation	Recovery	---	Log category	System
Effects	User program	Continues.	Operation	The relevant instruction will end according to specifications.		
System-defined variables	Variable		Data type		Name	
	_MC_AX[*].MFaultLvl.Active		BOOL		Axis Minor Fault Occurrence	
Cause and correction	Assumed cause		Correction		Prevention	
	Instruction input parameter exceeded the valid range of the input variable.		Correct the parameter so that the valid range of the input variable is not exceeded for the relevant instruction.		Set the input parameter to the instruction so that the valid range of the input variable is not exceeded.	
Attached information	<p>Attached Information 1: Error Location</p> <p>Attached Information 2: Error Location Details (Rung Number). For a program section, the rung number from the start of the section is given. For ST, the line number is given.</p> <p>Attached Information 3: Names of the Instruction and Instruction Instance Where the Error Occurred. If there is more than one possible instruction, information is given on all of them. Nothing is given if the instruction cannot be identified.</p> <p>Attached Information 4: Expansion Error Code (<i>ErrorIDEx</i>)</p>					
Precautions/Remarks	If a program is changed after an error occurs, the attached information that is displayed may not be correct.					

Event name	Last Position Setting Out of Range			Event code	5401546A hex	
Meaning	The parameter specified for the <i>LastPosition</i> input variable to a motion control instruction is out of range.					
Source	PLC Function Module		Source details	Instruction	Detection timing	At instruction execution
Error attributes	Level	Observation	Recovery	---	Log category	System
Effects	User program	Continues.	Operation	The relevant instruction will end according to specifications.		
System-defined variables	Variable		Data type		Name	
	_MC_AX[*].MFaultLvl.Active		BOOL		Axis Minor Fault Occurrence	
Cause and correction	Assumed cause		Correction		Prevention	
	Instruction input parameter exceeded the valid range of the input variable.		Correct the parameter so that the valid range of the input variable is not exceeded for the relevant instruction.		Set the input parameter to the instruction so that the valid range of the input variable is not exceeded.	
Attached information	<p>Attached Information 1: Error Location</p> <p>Attached Information 2: Error Location Details (Rung Number). For a program section, the rung number from the start of the section is given. For ST, the line number is given.</p> <p>Attached Information 3: Names of the Instruction and Instruction Instance Where the Error Occurred. If there is more than one possible instruction, information is given on all of them. Nothing is given if the instruction cannot be identified.</p> <p>Attached Information 4: Expansion Error Code (<i>ErrorIDEx</i>)</p>					
Precautions/Remarks	If a program is changed after an error occurs, the attached information that is displayed may not be correct.					

Event name	Illegal First/Last Position Size Relationship (Linear Mode)		Event code	5401546B hex		
Meaning	The parameter specified for the <i>LastPosition</i> input variable to a motion control instruction is smaller than the parameter specified for the <i>FirstPosition</i> input variable.					
Source	PLC Function Module		Source details	Instruction	Detection timing	At instruction execution
Error attributes	Level	Observation	Recovery	---	Log category	System
Effects	User program	Continues.	Operation	The relevant instruction will end according to specifications.		
System-defined variables	Variable		Data type		Name	
	_MC_AX[*].MFaultLvl.Active		BOOL		Axis Minor Fault Occurrence	
Cause and correction	Assumed cause		Correction		Prevention	
	The value of the <i>LastPosition</i> input parameter is less than the value of the <i>FirstPosition</i> input variable for the instruction when the Count Mode is set to Linear Mode.		Correct the program so that the value of the <i>LastPosition</i> specified for the instruction is larger than the value of the <i>FirstPosition</i> . Or, change the value of the Count Mode to Rotary Mode.		Write the program so that the value of the <i>LastPosition</i> specified for the instruction is larger than the value of the <i>FirstPosition</i> . Or, check to make sure that the Count Mode of the relevant axis is set to Rotary Mode.	
Attached information	Attached Information 1: Error Location Attached Information 2: Error Location Details (Rung Number). For a program section, the rung number from the start of the section is given. For ST, the line number is given. Attached Information 3: Names of the Instruction and Instruction Instance Where the Error Occurred. If there is more than one possible instruction, information is given on all of them. Nothing is given if the instruction cannot be identified. Attached Information 4: Expansion Error Code (<i>ErrorIDEx</i>)					
Precautions/Remarks	If a program is changed after an error occurs, the attached information that is displayed may not be correct.					

Event name	Master Sync Start Position Setting Out of Range		Event code	5401546C hex		
Meaning	The parameter specified for the <i>MasterSyncPosition</i> input variable to a motion control instruction is out of range.					
Source	PLC Function Module		Source details	Instruction	Detection timing	At instruction execution
Error attributes	Level	Observation	Recovery	---	Log category	System
Effects	User program	Continues.	Operation	The relevant instruction will end according to specifications.		
System-defined variables	Variable		Data type		Name	
	_MC_AX[*].MFaultLvl.Active		BOOL		Axis Minor Fault Occurrence	
Cause and correction	Assumed cause		Correction		Prevention	
	Instruction input parameter exceeded the valid range of the input variable.		Correct the parameter so that the valid range of the input variable is not exceeded for the relevant instruction.		Set the input parameter to the instruction so that the valid range of the input variable is not exceeded.	
Attached information	Attached Information 1: Error Location Attached Information 2: Error Location Details (Rung Number). For a program section, the rung number from the start of the section is given. For ST, the line number is given. Attached Information 3: Names of the Instruction and Instruction Instance Where the Error Occurred. If there is more than one possible instruction, information is given on all of them. Nothing is given if the instruction cannot be identified. Attached Information 4: Expansion Error Code (<i>ErrorIDEx</i>)					
Precautions/Remarks	If a program is changed after an error occurs, the attached information that is displayed may not be correct.					

Event name	Slave Sync Start Position Setting Out of Range		Event code	5401546D hex		
Meaning	The parameter specified for the <i>SlaveSyncPosition</i> input variable to a motion control instruction is out of range.					
Source	PLC Function Module		Source details	Instruction	Detection timing	At instruction execution
Error attributes	Level	Observation	Recovery	---	Log category	System
Effects	User program	Continues.	Operation	The relevant instruction will end according to specifications.		
System-defined variables	Variable		Data type		Name	
	_MC_AX[*].MFAultLvl.Active		BOOL		Axis Minor Fault Occurrence	
Cause and correction	Assumed cause		Correction		Prevention	
	Instruction input parameter exceeded the valid range of the input variable.		Correct the parameter so that the valid range of the input variable is not exceeded for the relevant instruction.		Set the input parameter to the instruction so that the valid range of the input variable is not exceeded.	
Attached information	<p>Attached Information 1: Error Location</p> <p>Attached Information 2: Error Location Details (Rung Number). For a program section, the rung number from the start of the section is given. For ST, the line number is given.</p> <p>Attached Information 3: Names of the Instruction and Instruction Instance Where the Error Occurred. If there is more than one possible instruction, information is given on all of them. Nothing is given if the instruction cannot be identified.</p> <p>Attached Information 4: Expansion Error Code (<i>ErrorIDEx</i>)</p>					
Precautions/Remarks	If a program is changed after an error occurs, the attached information that is displayed may not be correct.					

Event name	Duplicate Latch ID for Trigger Input Condition		Event code	5401546E hex		
Meaning	The same latch ID was specified for more than one motion control instruction.					
Source	PLC Function Module		Source details	Instruction	Detection timing	At instruction execution
Error attributes	Level	Observation	Recovery	---	Log category	System
Effects	User program	Continues.	Operation	The relevant instruction will end according to specifications.		
System-defined variables	Variable		Data type		Name	
	_MC_AX[*].MFAultLvl.Active		BOOL		Axis Minor Fault Occurrence	
Cause and correction	Assumed cause		Correction		Prevention	
	The same latch ID is used simultaneously for more than one of the following instructions: MC_TouchProbe (Enable External Latch) instruction, MC_MoveLink (Synchronous Positioning) instruction, and MC_MoveFeed (Interrupt Feeding) instruction.		Correct the program so that the same latch ID is not used by another instruction at the same time as this instruction. Either use a different latch ID or do not execute any instructions that use the same latch ID at the same time. Both latch 1 and latch 2 are treated as being in use during execution of the MC_Home or MC_HomeWithParameter instruction.		Do not use the same latch ID simultaneously for more than one of the following instructions: MC_TouchProbe (Enable External Latch) instruction, MC_MoveLink (Synchronous Positioning) instruction, and MC_MoveFeed (Interrupt Feeding) instruction.	
Cause and correction	The MC_AbortTrigger (Disable External Latch) instruction was executed to cancel a latch that was used by an instruction other than the MC_TouchProbe (Enable External Latch) instruction.		Do not use the Disable External Latch instruction to cancel a latch that is used by an instruction other than the Enable External Latch instruction.		Do not execute the Disable External Latch instruction for a latch that is used by an instruction other than the Enable External Latch instruction.	
Attached information	<p>Attached Information 1: Error Location</p> <p>Attached Information 2: Error Location Details (Rung Number). For a program section, the rung number from the start of the section is given. For ST, the line number is given.</p> <p>Attached Information 3: Names of the Instruction and Instruction Instance Where the Error Occurred. If there is more than one possible instruction, information is given on all of them. Nothing is given if the instruction cannot be identified.</p> <p>Attached Information 4: Expansion Error Code (<i>ErrorIDEx</i>)</p>					
Precautions/Remarks	<ul style="list-style-type: none"> If a program is changed after an error occurs, the attached information that is displayed may not be correct. If you decide to change the latch ID, make sure that same latch ID is not used by any other instructions. 					

Event name	Jerk Override Factor Out of Range			Event code	5401546F hex	
Meaning	The parameter specified for the <i>JerkFactor</i> input variable to a motion control instruction is out of range.					
Source	PLC Function Module		Source details	Instruction	Detection timing	At instruction execution
Error attributes	Level	Observation	Recovery	---	Log category	System
Effects	User program	Continues.	Operation	The relevant instruction will end according to specifications.		
System-defined variables	Variable		Data type		Name	
	_MC_AX[*].MFaultLvl.Active		BOOL		Axis Minor Fault Occurrence	
Cause and correction	Assumed cause		Correction		Prevention	
	Instruction input parameter exceeded the valid range of the input variable.		Correct the parameter so that the valid range of the input variable is not exceeded for the relevant instruction.		Set the input parameter to the instruction so that the valid range of the input variable is not exceeded.	
Attached information	<p>Attached Information 1: Error Location</p> <p>Attached Information 2: Error Location Details (Rung Number). For a program section, the rung number from the start of the section is given. For ST, the line number is given.</p> <p>Attached Information 3: Names of the Instruction and Instruction Instance Where the Error Occurred. If there is more than one possible instruction, information is given on all of them. Nothing is given if the instruction cannot be identified.</p> <p>Attached Information 4: Expansion Error Code (<i>ErrorIDEx</i>)</p>					
Precautions/Remarks	If a program is changed after an error occurs, the attached information that is displayed may not be correct.					

Event name	Acceleration/Deceleration Override Factor Out of Range			Event code	54015470 hex	
Meaning	The parameter specified for the <i>AccFactor</i> input variable to a motion control instruction is out of range.					
Source	PLC Function Module		Source details	Instruction	Detection timing	At instruction execution
Error attributes	Level	Observation	Recovery	---	Log category	System
Effects	User program	Continues.	Operation	The relevant instruction will end according to specifications.		
System-defined variables	Variable		Data type		Name	
	_MC_AX[*].MFaultLvl.Active		BOOL		Axis Minor Fault Occurrence	
Cause and correction	Assumed cause		Correction		Prevention	
	Instruction input parameter exceeded the valid range of the input variable.		Correct the parameter so that the valid range of the input variable is not exceeded for the relevant instruction.		Set the input parameter to the instruction so that the valid range of the input variable is not exceeded.	
Attached information	<p>Attached Information 1: Error Location</p> <p>Attached Information 2: Error Location Details (Rung Number). For a program section, the rung number from the start of the section is given. For ST, the line number is given.</p> <p>Attached Information 3: Names of the Instruction and Instruction Instance Where the Error Occurred. If there is more than one possible instruction, information is given on all of them. Nothing is given if the instruction cannot be identified.</p> <p>Attached Information 4: Expansion Error Code (<i>ErrorIDEx</i>)</p>					
Precautions/Remarks	If a program is changed after an error occurs, the attached information that is displayed may not be correct.					

Event name	First Position Method Specification Out of Range		Event code	54015471 hex		
Meaning	The parameter specified for the <i>StartMode</i> input variable to a motion control instruction is out of range.					
Source	PLC Function Module		Source details	Instruction	Detection timing	At instruction execution
Error attributes	Level	Observation	Recovery	---	Log category	System
Effects	User program	Continues.	Operation	The relevant instruction will end according to specifications.		
System-defined variables	Variable		Data type		Name	
	_MC_AX[*].MFaultLvl.Active		BOOL		Axis Minor Fault Occurrence	
Cause and correction	Assumed cause		Correction		Prevention	
	Instruction input parameter exceeded the valid range of the input variable.		Correct the parameter so that the valid range of the input variable is not exceeded for the relevant instruction.		Set the input parameter to the instruction so that the valid range of the input variable is not exceeded.	
Attached information	<p>Attached Information 1: Error Location</p> <p>Attached Information 2: Error Location Details (Rung Number). For a program section, the rung number from the start of the section is given. For ST, the line number is given.</p> <p>Attached Information 3: Names of the Instruction and Instruction Instance Where the Error Occurred. If there is more than one possible instruction, information is given on all of them. Nothing is given if the instruction cannot be identified.</p> <p>Attached Information 4: Expansion Error Code (<i>ErrorIDEx</i>)</p>					
Precautions/Remarks	If a program is changed after an error occurs, the attached information that is displayed may not be correct.					

Event name	Motion Control Instruction Re-execution Disabled (First Position Method)		Event code	54015472 hex		
Meaning	An attempt was made to change the <i>StartMode</i> input variable when re-executing a motion control instruction. (This input variable cannot be changed when re-executing an instruction.)					
Source	PLC Function Module		Source details	Instruction	Detection timing	At instruction re-execution
Error attributes	Level	Observation	Recovery	---	Log category	System
Effects	User program	Continues.	Operation	The relevant instruction will end according to specifications.		
System-defined variables	Variable		Data type		Name	
	_MC_AX[*].MFaultLvl.Active		BOOL		Axis Minor Fault Occurrence	
Cause and correction	Assumed cause		Correction		Prevention	
	A parameter for an input variable that cannot be changed for re-execution was changed.		Correct the program so that the parameter for the relevant input variable does not change when the relevant instruction is re-executed.		Check the manual to see if the input variables to the relevant motion control instruction can be changed by re-execution. Write the program so that the input parameters for any input variable that cannot be changed do not change upon re-execution.	
Attached information	<p>Attached Information 1: Error Location</p> <p>Attached Information 2: Error Location Details (Rung Number). For a program section, the rung number from the start of the section is given. For ST, the line number is given.</p> <p>Attached Information 3: Names of the Instruction and Instruction Instance Where the Error Occurred. If there is more than one possible instruction, information is given on all of them. Nothing is given if the instruction cannot be identified.</p> <p>Attached Information 4: Expansion Error Code (<i>ErrorIDEx</i>)</p>					
Precautions/Remarks	If a program is changed after an error occurs, the attached information that is displayed may not be correct.					

Event name	Unused Axis Specification for Auxiliary Axis			Event code	54015474 hex	
Meaning	The axis specified for the <i>Auxiliary</i> input variable to a motion control instruction is an unused axis.					
Source	PLC Function Module		Source details	Instruction	Detection timing	At instruction execution
Error attributes	Level	Observation	Recovery	---	Log category	System
Effects	User program	Continues.	Operation	The relevant instruction will end according to specifications.		
System-defined variables	Variable		Data type		Name	
	_MC_AX[*].MFaultLvl.Active		BOOL		Axis Minor Fault Occurrence	
Cause and correction	Assumed cause		Correction		Prevention	
	The axis specified for the <i>Auxiliary</i> input variable to the instruction is an unused axis.		Set a used axis for the axis that is specified for the instruction. Or, correct the parameter so that it specifies a used axis.		Make sure that the axis specified for the instruction is a used axis.	
Attached information	<p>Attached Information 1: Error Location</p> <p>Attached Information 2: Error Location Details (Rung Number). For a program section, the rung number from the start of the section is given. For ST, the line number is given.</p> <p>Attached Information 3: Names of the Instruction and Instruction Instance Where the Error Occurred. If there is more than one possible instruction, information is given on all of them. Nothing is given if the instruction cannot be identified.</p> <p>Attached Information 4: Expansion Error Code (<i>ErrorIDEx</i>)</p>					
Precautions/Remarks	If a program is changed after an error occurs, the attached information that is displayed may not be correct.					

Event name	Position Gear Value Error			Event code	54015475 hex	
Meaning	Synchronized motion is not possible for the velocity, acceleration rate, and deceleration rate that were input to a motion control instruction.					
Source	PLC Function Module		Source details	Instruction	Detection timing	At instruction execution
Error attributes	Level	Observation	Recovery	---	Log category	System
Effects	User program	Continues.	Operation	The relevant instruction will end according to specifications.		
System-defined variables	Variable		Data type		Name	
	_MC_AX[*].MFaultLvl.Active		BOOL		Axis Minor Fault Occurrence	
Cause and correction	Assumed cause		Correction		Prevention	
	The specified synchronized motion cannot be performed at the velocity, acceleration rate, or deceleration rate that is input to the instruction.		Correct the program to enable synchronized motion according to the operating specifications of the MC_GearInPos (Positioning Gear Operation) instruction.		Check the processing of the relevant instruction and set a value that allows for synchronized motion.	
Attached information	<p>Attached Information 1: Error Location</p> <p>Attached Information 2: Error Location Details (Rung Number). For a program section, the rung number from the start of the section is given. For ST, the line number is given.</p> <p>Attached Information 3: Names of the Instruction and Instruction Instance Where the Error Occurred. If there is more than one possible instruction, information is given on all of them. Nothing is given if the instruction cannot be identified.</p> <p>Attached Information 4: Expansion Error Code (<i>ErrorIDEx</i>)</p>					
Precautions/Remarks	If a program is changed after an error occurs, the attached information that is displayed may not be correct.					

Event name	Position Gear Master Axis Zero Velocity		Event code	54015476 hex		
Meaning	The velocity of the master axis was zero when a motion control instruction was started.					
Source	PLC Function Module		Source details	Instruction	Detection timing	At instruction execution
Error attributes	Level	Observation	Recovery	---	Log category	System
Effects	User program	Continues.	Operation	The relevant instruction will end according to specifications.		
System-defined variables	Variable		Data type		Name	
	_MC_AX[*].MFaultLvl.Active		BOOL		Axis Minor Fault Occurrence	
Cause and correction	Assumed cause		Correction		Prevention	
	The velocity of the master axis was 0 when the instruction was started.		Correct the program so that the velocity of the master axis is not 0 when the instruction is started.		Write the program so that the velocity of the master axis is not 0 when the instruction is started.	
Attached information	<p>Attached Information 1: Error Location</p> <p>Attached Information 2: Error Location Details (Rung Number). For a program section, the rung number from the start of the section is given. For ST, the line number is given.</p> <p>Attached Information 3: Names of the Instruction and Instruction Instance Where the Error Occurred. If there is more than one possible instruction, information is given on all of them. Nothing is given if the instruction cannot be identified.</p> <p>Attached Information 4: Expansion Error Code (<i>ErrorIDEx</i>)</p>					
Precautions/Remarks	If a program is changed after an error occurs, the attached information that is displayed may not be correct.					

Event name	Target Position Setting Out of Range		Event code	54015478 hex		
Meaning	The parameter specified for the <i>Position</i> input variable to a motion control instruction is out of range.					
Source	PLC Function Module		Source details	Instruction	Detection timing	At instruction execution
Error attributes	Level	Observation	Recovery	---	Log category	System
Effects	User program	Continues.	Operation	The relevant instruction will end according to specifications.		
System-defined variables	Variable		Data type		Name	
	_MC_AX[*].MFaultLvl.Active		BOOL		Axis Minor Fault Occurrence	
	_MC_GRP[*].MFaultLvl.Active		BOOL		Axes Group Minor Fault Occurrence	
Cause and correction	Assumed cause		Correction		Prevention	
	Instruction input parameter exceeded the valid range of the input variable.		Correct the parameter so that the valid range of the input variable is not exceeded for the relevant instruction.		Set the input parameter to the instruction so that the valid range of the input variable is not exceeded.	
	The target position of a Rotary Mode axis is not within the ring setting range.		Correct the target position of the Rotary Mode axis to within the ring setting range.		Set the target position of the Rotary Mode axis to within the ring setting range.	
Attached information	<p>Attached Information 1: Error Location</p> <p>Attached Information 2: Error Location Details (Rung Number). For a program section, the rung number from the start of the section is given. For ST, the line number is given.</p> <p>Attached Information 3: Names of the Instruction and Instruction Instance Where the Error Occurred. If there is more than one possible instruction, information is given on all of them. Nothing is given if the instruction cannot be identified.</p> <p>Attached Information 4: Expansion Error Code (<i>ErrorIDEx</i>)</p>					
Precautions/Remarks	If a program is changed after an error occurs, the attached information that is displayed may not be correct.					

Event name	Travel Distance Out of Range			Event code	54015479 hex	
Meaning	The parameter that was specified for the <i>Distance</i> input variable to a motion control instruction is out of range or the target position with the value of <i>Distance</i> added is out of range.					
Source	PLC Function Module		Source details	Instruction	Detection timing	At instruction execution
Error attributes	Level	Observation	Recovery	---	Log category	System
Effects	User program	Continues.	Operation	The relevant instruction will end according to specifications.		
System-defined variables	Variable		Data type		Name	
	_MC_AX[*].MFaultLvl.Active		BOOL		Axis Minor Fault Occurrence	
	_MC_GRP[*].MFaultLvl.Active		BOOL		Axes Group Minor Fault Occurrence	
Cause and correction	Assumed cause		Correction		Prevention	
	<p>The absolute value of the instruction input parameter exceeded the range of 40-bit data when it is converted to pulses.</p> <p>For a Linear Mode axis, the target position with the travel distance added exceeded signed 40-bit data when the absolute value is converted to pulses.</p>		Correct the input parameter specified for the <i>Distance</i> input variable of the instruction so that the travel distance and the target position are not out of range.		Write the program so that the travel distance and the target position for the instruction are not out of range.	
Attached information	<p>Attached Information 1: Error Location</p> <p>Attached Information 2: Error Location Details (Rung Number). For a program section, the rung number from the start of the section is given. For ST, the line number is given.</p> <p>Attached Information 3: Names of the Instruction and Instruction Instance Where the Error Occurred. If there is more than one possible instruction, information is given on all of them. Nothing is given if the instruction cannot be identified.</p> <p>Attached Information 4: Expansion Error Code (<i>ErrorIDEx</i>)</p>					
Precautions/Remarks	If a program is changed after an error occurs, the attached information that is displayed may not be correct.					

Event name	Cam Table Start Point Setting Out of Range			Event code	5401547A hex	
Meaning	The parameter specified for the <i>StartPosition</i> input variable to a motion control instruction is out of range.					
Source	PLC Function Module		Source details	Instruction	Detection timing	At instruction execution
Error attributes	Level	Observation	Recovery	---	Log category	System
Effects	User program	Continues.	Operation	The relevant instruction will end according to specifications.		
System-defined variables	Variable		Data type		Name	
	_MC_AX[*].MFaultLvl.Active		BOOL		Axis Minor Fault Occurrence	
Cause and correction	Assumed cause		Correction		Prevention	
	Instruction input parameter exceeded the valid range of the input variable.		Correct the parameter so that the valid range of the input variable is not exceeded for the relevant instruction.		Set the input parameter to the instruction so that the valid range of the input variable is not exceeded.	
Attached information	<p>Attached Information 1: Error Location</p> <p>Attached Information 2: Error Location Details (Rung Number). For a program section, the rung number from the start of the section is given. For ST, the line number is given.</p> <p>Attached Information 3: Names of the Instruction and Instruction Instance Where the Error Occurred. If there is more than one possible instruction, information is given on all of them. Nothing is given if the instruction cannot be identified.</p> <p>Attached Information 4: Expansion Error Code (<i>ErrorIDEx</i>)</p>					
Precautions/Remarks	If a program is changed after an error occurs, the attached information that is displayed may not be correct.					

Event name	Cam Master Axis Following First Position Setting Out of Range		Event code	5401547B hex		
Meaning	The parameter specified for the <i>MasterStartDistance</i> input variable to a motion control instruction is out of range.					
Source	PLC Function Module		Source details	Instruction	Detection timing	At instruction execution
Error attributes	Level	Observation	Recovery	---	Log category	System
Effects	User program	Continues.	Operation	The relevant instruction will end according to specifications.		
System-defined variables	Variable		Data type		Name	
	_MC_AX[*].MFAultLvl.Active		BOOL		Axis Minor Fault Occurrence	
Cause and correction	Assumed cause		Correction		Prevention	
	Instruction input parameter exceeded the valid range of the input variable.		Correct the parameter so that the valid range of the input variable is not exceeded for the relevant instruction.		Set the input parameter to the instruction so that the valid range of the input variable is not exceeded.	
Attached information	<p>Attached Information 1: Error Location</p> <p>Attached Information 2: Error Location Details (Rung Number). For a program section, the rung number from the start of the section is given. For ST, the line number is given.</p> <p>Attached Information 3: Names of the Instruction and Instruction Instance Where the Error Occurred. If there is more than one possible instruction, information is given on all of them. Nothing is given if the instruction cannot be identified.</p> <p>Attached Information 4: Expansion Error Code (<i>ErrorIDEx</i>)</p>					
Precautions/Remarks	If a program is changed after an error occurs, the attached information that is displayed may not be correct.					

Event name	Circular Interpolation Radius Setting Error		Event code	5401547C hex		
Meaning	It was not possible to create a circular path for the specified radius when the radius method was specified for the MC_MoveCircular2D (Circular 2D Interpolation) instruction.					
Source	PLC Function Module		Source details	Instruction	Detection timing	At instruction execution
Error attributes	Level	Observation	Recovery	---	Log category	System
Effects	User program	Continues.	Operation	The relevant instruction will end according to specifications.		
System-defined variables	Variable		Data type		Name	
	_MC_GRP[*].MFAultLvl.Active		BOOL		Axes Group Minor Fault Occurrence	
Cause and correction	Assumed cause		Correction		Prevention	
	For the MC_MoveCircular2D (Circular 2D Interpolation) instruction, it was not possible to create a circular path for the specified radius when the radius method was specified for circular interpolation.		Correct the radius so that the circular path can be created.		Check the processing of the relevant instruction and set a radius that allows the creation of a circular path.	
Attached information	<p>Attached Information 1: Error Location</p> <p>Attached Information 2: Error Location Details (Rung Number). For a program section, the rung number from the start of the section is given. For ST, the line number is given.</p> <p>Attached Information 3: Names of the Instruction and Instruction Instance Where the Error Occurred. If there is more than one possible instruction, information is given on all of them. Nothing is given if the instruction cannot be identified.</p> <p>Attached Information 4: Expansion Error Code (<i>ErrorIDEx</i>)</p>					
Precautions/Remarks	If a program is changed after an error occurs, the attached information that is displayed may not be correct.					

Event name	Circular Interpolation Radius Overflow		Event code	5401547D hex		
Meaning	For the MC_MoveCircular2D (Circular 2D Interpolation) instruction, the radius of the circle exceeded the maximum value for the border point or center specification method.					
Source	PLC Function Module		Source details	Instruction	Detection timing	At instruction execution
Error attributes	Level	Observation	Recovery	---	Log category	System
Effects	User program	Continues.	Operation	The relevant instruction will end according to specifications.		
System-defined variables	Variable		Data type		Name	
	_MC_GRP[*].MFaultLvl.Active		BOOL		Axes Group Minor Fault Occurrence	
Cause and correction	Assumed cause		Correction		Prevention	
	For the MC_MoveCircular2D (Circular 2D Interpolation) instruction, the radius of the circle exceeded 40-bit data when it is converted to pulses for the border point or center specification method.		Correct the input parameter so that the circle radius does not exceed 40-bit data when it is converted to pulses based on the operating specifications of the instruction. Border point specification: Start point, border point, and end point Center point specification: Start point, end point, and center point		Check the processing of the instruction and correct the input parameters so that the circle radius does not exceed 40-bit data when it is converted to pulses.	
Attached information	Attached Information 1: Error Location Attached Information 2: Error Location Details (Rung Number). For a program section, the rung number from the start of the section is given. For ST, the line number is given. Attached Information 3: Names of the Instruction and Instruction Instance Where the Error Occurred. If there is more than one possible instruction, information is given on all of them. Nothing is given if the instruction cannot be identified. Attached Information 4: Expansion Error Code (<i>ErrorIDEx</i>)					
Precautions/Remarks	<ul style="list-style-type: none"> • If a program is changed after an error occurs, the attached information that is displayed may not be correct. • If the maximum radius is exceeded when the radius specification method is used, a Border Point/Center Position/Radius Specification Out of Range error occurs. 					

Event name	Circular Interpolation Setting Out of Range		Event code	5401547E hex		
Meaning	The parameter specified for the <i>CircAxes</i> input variable to a motion control instruction is out of range.					
Source	PLC Function Module		Source details	Instruction	Detection timing	At instruction execution
Error attributes	Level	Observation	Recovery	---	Log category	System
Effects	User program	Continues.	Operation	The relevant instruction will end according to specifications.		
System-defined variables	Variable		Data type		Name	
	_MC_GRP[*].MFaultLvl.Active		BOOL		Axes Group Minor Fault Occurrence	
Cause and correction	Assumed cause		Correction		Prevention	
	Instruction input parameter exceeded the valid range of the input variable.		Correct the parameter so that the valid range of the input variable is not exceeded for the relevant instruction.		Set the input parameters to the instruction so that the valid range of the input variables is not exceeded.	
	The axes that were specified in <i>CircAxes</i> are not included in the composition axes in the Axes Group Settings.		Set the axes that are specified for <i>CircAxes</i> so that they are in an axes group configuration.		Make sure that the axes that are specified for <i>CircAxes</i> are in an axes group configuration.	
	The same axis was specified for both axes of <i>CircAxes</i> .		Correct the settings so that the two axes specified for <i>CircAxes</i> are different axes.		Write the program so that the two axes specified for <i>CircAxes</i> are different axes.	
Attached information	<p>Attached Information 1: Error Location</p> <p>Attached Information 2: Error Location Details (Rung Number). For a program section, the rung number from the start of the section is given. For ST, the line number is given.</p> <p>Attached Information 3: Names of the Instruction and Instruction Instance Where the Error Occurred. If there is more than one possible instruction, information is given on all of them. Nothing is given if the instruction cannot be identified.</p> <p>Attached Information 4: Expansion Error Code (<i>ErrorIDEx</i>)</p>					
Precautions/Remarks	If a program is changed after an error occurs, the attached information that is displayed may not be correct.					

Event name	Auxiliary/Slave Axis Numbers Not in Ascending Order		Event code	5401547F hex		
Meaning	The values of the parameters for the <i>Auxiliary</i> and <i>Slave</i> input variables to a motion control instruction are not in ascending order.					
Source	PLC Function Module		Source details	Instruction	Detection timing	At instruction execution
Error attributes	Level	Observation	Recovery	---	Log category	System
Effects	User program	Continues.	Operation	The relevant instruction will end according to specifications.		
System-defined variables	Variable		Data type		Name	
	_MC_AX[*].MFaultLvl.Active		BOOL		Axis Minor Fault Occurrence	
Cause and correction	Assumed cause		Correction		Prevention	
	The parameters for the <i>Auxiliary</i> and <i>Slave</i> input variables to the instruction are not in ascending order.		Correct the axis numbers specified for the <i>Auxiliary</i> and <i>Slave</i> input parameters to the instruction so that they are in ascending order.		Write the program so that the axis numbers specified for <i>Auxiliary</i> and <i>Slave</i> are in ascending order.	
Attached information	<p>Attached Information 1: Error Location</p> <p>Attached Information 2: Error Location Details (Rung Number). For a program section, the rung number from the start of the section is given. For ST, the line number is given.</p> <p>Attached Information 3: Names of the Instruction and Instruction Instance Where the Error Occurred. If there is more than one possible instruction, information is given on all of them. Nothing is given if the instruction cannot be identified.</p> <p>Attached Information 4: Expansion Error Code (<i>ErrorIDEx</i>)</p>					
Precautions/Remarks	If a program is changed after an error occurs, the attached information that is displayed may not be correct.					

Event name	Cam Table Property Ascending Data Error at Update		Event code	54015480 hex		
Meaning	A phase that was not in ascending order was found during calculating the number of valid data. Or, after calculations, the number of valid data is 0.					
Source	PLC Function Module		Source details	Instruction	Detection timing	During instruction execution
Error attributes	Level	Observation	Recovery	---	Log category	System
Effects	User program	Continues.	Operation	The relevant instruction will end according to specifications.		
System-defined variables	Variable		Data type		Name	
	_MC_COM.MFaultLvl.Active		BOOL		MC Common Minor Fault Occurrence	
Cause and correction	Assumed cause		Correction		Prevention	
	A phase that was not in ascending order was found when calculating the number of valid data.		Place the phase data into ascending order in the cam table data.		Place the phase data into ascending order in the cam table data.	
	After calculations, the number of valid data is 0.		Correct the cam table data so that it includes phases that are not 0.		Create the cam table data so that it includes phases that are not 0.	
Attached information	<p>Attached Information 1: Error Location</p> <p>Attached Information 2: Error Location Details (Rung Number). For a program section, the rung number from the start of the section is given. For ST, the line number is given.</p> <p>Attached Information 3: Names of the Instruction and Instruction Instance Where the Error Occurred. If there is more than one possible instruction, information is given on all of them. Nothing is given if the instruction cannot be identified.</p> <p>Attached Information 4: Expansion Error Code (<i>ErrorIDEx</i>)</p>					
Precautions/Remarks	If a program is changed after an error occurs, the attached information that is displayed may not be correct.					

Event name	MC_Write Target Out of Range		Event code	54015481 hex		
Meaning	The parameter specified for the <i>Target</i> input variable to a motion control instruction is out of range.					
Source	PLC Function Module		Source details	Instruction	Detection timing	At instruction execution
Error attributes	Level	Observation	Recovery	---	Log category	System
Effects	User program	Continues.	Operation	The relevant instruction will end according to specifications.		
System-defined variables	Variable		Data type		Name	
	_MC_COM.MFaultLvl.Active		BOOL		MC Common Minor Fault Occurrence	
Cause and correction	Assumed cause		Correction		Prevention	
	Instruction input parameter exceeded the valid range of the input variable.		Correct the parameter so that the valid range of the input variable is not exceeded for the relevant instruction.		Set the input parameter to the instruction so that the valid range of the input variable is not exceeded.	
Attached information	<p>Attached Information 1: Error Location</p> <p>Attached Information 2: Error Location Details (Rung Number). For a program section, the rung number from the start of the section is given. For ST, the line number is given.</p> <p>Attached Information 3: Names of the Instruction and Instruction Instance Where the Error Occurred. If there is more than one possible instruction, information is given on all of them. Nothing is given if the instruction cannot be identified.</p> <p>Attached Information 4: Expansion Error Code (<i>ErrorIDEx</i>)</p>					
Precautions/Remarks	If a program is changed after an error occurs, the attached information that is displayed may not be correct.					

Event name	Master Travel Distance Specification Out of Range		Event code	54015482 hex		
Meaning	The parameter specified for the <i>MasterDistance</i> input variable to a motion control instruction is out of range.					
Source	PLC Function Module		Source details	Instruction	Detection timing	At instruction execution
Error attributes	Level	Observation	Recovery	---	Log category	System
Effects	User program	Continues.	Operation	The relevant instruction will end according to specifications.		
System-defined variables	Variable		Data type		Name	
	_MC_AX[*].MFaultLvl.Active		BOOL		Axis Minor Fault Occurrence	
Cause and correction	Assumed cause		Correction		Prevention	
	Instruction input parameter exceeded the valid range of the input variable.		Correct the parameter so that the valid range of the input variable is not exceeded for the relevant instruction.		Set the input parameter to the instruction so that the valid range of the input variable is not exceeded.	
Attached information	<p>Attached Information 1: Error Location</p> <p>Attached Information 2: Error Location Details (Rung Number). For a program section, the rung number from the start of the section is given. For ST, the line number is given.</p> <p>Attached Information 3: Names of the Instruction and Instruction Instance Where the Error Occurred. If there is more than one possible instruction, information is given on all of them. Nothing is given if the instruction cannot be identified.</p> <p>Attached Information 4: Expansion Error Code (<i>ErrorIDEx</i>)</p>					
Precautions/Remarks	If a program is changed after an error occurs, the attached information that is displayed may not be correct.					

Event name	Master Distance in Acceleration Specification Out of Range		Event code	54015483 hex		
Meaning	The parameter specified for the <i>MasterDistanceACC</i> input variable to a motion control instruction is out of range.					
Source	PLC Function Module		Source details	Instruction	Detection timing	At instruction execution
Error attributes	Level	Observation	Recovery	---	Log category	System
Effects	User program	Continues.	Operation	The relevant instruction will end according to specifications.		
System-defined variables	Variable		Data type		Name	
	_MC_AX[*].MFaultLvl.Active		BOOL		Axis Minor Fault Occurrence	
Cause and correction	Assumed cause		Correction		Prevention	
	Instruction input parameter exceeded the valid range of the input variable.		Correct the parameter so that the valid range of the input variable is not exceeded for the relevant instruction.		Set the input parameter to the instruction so that the valid range of the input variable is not exceeded.	
Attached information	<p>Attached Information 1: Error Location</p> <p>Attached Information 2: Error Location Details (Rung Number). For a program section, the rung number from the start of the section is given. For ST, the line number is given.</p> <p>Attached Information 3: Names of the Instruction and Instruction Instance Where the Error Occurred. If there is more than one possible instruction, information is given on all of them. Nothing is given if the instruction cannot be identified.</p> <p>Attached Information 4: Expansion Error Code (<i>ErrorIDEx</i>)</p>					
Precautions/Remarks	If a program is changed after an error occurs, the attached information that is displayed may not be correct.					

Event name	Master Distance in Deceleration Specification Out of Range			Event code	54015484 hex	
Meaning	The parameter specified for the <i>MasterDistanceDEC</i> input variable to a motion control instruction is out of range.					
Source	PLC Function Module		Source details	Instruction	Detection timing	At instruction execution
Error attributes	Level	Observation	Recovery	---	Log category	System
Effects	User program	Continues.	Operation	The relevant instruction will end according to specifications.		
System-defined variables	Variable		Data type		Name	
	_MC_AX[*].MFaultLvl.Active		BOOL		Axis Minor Fault Occurrence	
Cause and correction	Assumed cause		Correction		Prevention	
	Instruction input parameter exceeded the valid range of the input variable.		Correct the parameter so that the valid range of the input variable is not exceeded for the relevant instruction.		Set the input parameter to the instruction so that the valid range of the input variable is not exceeded.	
Attached information	<p>Attached Information 1: Error Location</p> <p>Attached Information 2: Error Location Details (Rung Number). For a program section, the rung number from the start of the section is given. For ST, the line number is given.</p> <p>Attached Information 3: Names of the Instruction and Instruction Instance Where the Error Occurred. If there is more than one possible instruction, information is given on all of them. Nothing is given if the instruction cannot be identified.</p> <p>Attached Information 4: Expansion Error Code (<i>ErrorIDEx</i>)</p>					
Precautions/Remarks	If a program is changed after an error occurs, the attached information that is displayed may not be correct.					

Event name	Execution Mode Selection Out of Range			Event code	54015487 hex	
Meaning	The parameter specified for the <i>ExecutionMode</i> input variable to a motion control instruction is out of range.					
Source	PLC Function Module		Source details	Instruction	Detection timing	At instruction execution
Error attributes	Level	Observation	Recovery	---	Log category	System
Effects	User program	Continues.	Operation	The relevant instruction will end according to specifications.		
System-defined variables	Variable		Data type		Name	
	_MC_AX[*].MFaultLvl.Active		BOOL		Axis Minor Fault Occurrence	
Cause and correction	Assumed cause		Correction		Prevention	
	Instruction input parameter exceeded the valid range of the input variable.		Correct the parameter so that the valid range of the input variable is not exceeded for the relevant instruction.		Set the input parameter to the instruction so that the valid range of the input variable is not exceeded.	
Attached information	<p>Attached Information 1: Error Location</p> <p>Attached Information 2: Error Location Details (Rung Number). For a program section, the rung number from the start of the section is given. For ST, the line number is given.</p> <p>Attached Information 3: Names of the Instruction and Instruction Instance Where the Error Occurred. If there is more than one possible instruction, information is given on all of them. Nothing is given if the instruction cannot be identified.</p> <p>Attached Information 4: Expansion Error Code (<i>ErrorIDEx</i>)</p>					
Precautions/Remarks	If a program is changed after an error occurs, the attached information that is displayed may not be correct.					

Event name	Permitted Following Error Out of Range		Event code	54015488 hex		
Meaning	The parameter specified for the <i>PermittedDeviation</i> input variable to a motion control instruction is out of range.					
Source	PLC Function Module		Source details	Instruction	Detection timing	At instruction execution
Error attributes	Level	Observation	Recovery	---	Log category	System
Effects	User program	Continues.	Operation	The relevant instruction will end according to specifications.		
System-defined variables	Variable		Data type		Name	
	_MC_COM.MFaultLvl.Active		BOOL		MC Common Minor Fault Occurrence	
Cause and correction	Assumed cause		Correction		Prevention	
	Instruction input parameter exceeded the valid range of the input variable.		Correct the parameter so that the valid range of the input variable is not exceeded for the relevant instruction.		Set the input parameter to the instruction so that the valid range of the input variable is not exceeded.	
Attached information	<p>Attached Information 1: Error Location</p> <p>Attached Information 2: Error Location Details (Rung Number). For a program section, the rung number from the start of the section is given. For ST, the line number is given.</p> <p>Attached Information 3: Names of the Instruction and Instruction Instance Where the Error Occurred. If there is more than one possible instruction, information is given on all of them. Nothing is given if the instruction cannot be identified.</p> <p>Attached Information 4: Expansion Error Code (<i>ErrorIDEx</i>)</p>					
Precautions/Remarks	If a program is changed after an error occurs, the attached information that is displayed may not be correct.					

Event name	Border Point/Center Position/Radius Specification Out of Range		Event code	54015489 hex		
Meaning	The parameter specified for the <i>AuxPoint</i> input variable to a motion control instruction is out of range.					
Source	PLC Function Module		Source details	Instruction	Detection timing	At instruction execution
Error attributes	Level	Observation	Recovery	---	Log category	System
Effects	User program	Continues.	Operation	The relevant instruction will end according to specifications.		
System-defined variables	Variable		Data type		Name	
	_MC_GRP[*].MFaultLvl.Active		BOOL		Axes Group Minor Fault Occurrence	
Cause and correction	Assumed cause		Correction		Prevention	
	<p>The value of <i>AuxPoint</i> exceeded signed 40-bit data when it is converted to pulses for the border point or center specification method.</p> <p>For a radius specifications, the absolute value of <i>AuxPoint[0]</i> exceeded 40-bit data when it is converted to pulses.</p>		Correct the parameter so that the valid range of the input variable is not exceeded for the relevant instruction.		Set the input parameter to the instruction so that the valid range of the input variable is not exceeded.	
Attached information	<p>Attached Information 1: Error Location</p> <p>Attached Information 2: Error Location Details (Rung Number). For a program section, the rung number from the start of the section is given. For ST, the line number is given.</p> <p>Attached Information 3: Names of the Instruction and Instruction Instance Where the Error Occurred. If there is more than one possible instruction, information is given on all of them. Nothing is given if the instruction cannot be identified.</p> <p>Attached Information 4: Expansion Error Code (<i>ErrorIDEx</i>)</p>					
Precautions/Remarks	If a program is changed after an error occurs, the attached information that is displayed may not be correct.					

Event name	End Point Specification Out of Range			Event code	5401548A hex	
Meaning	The parameter specified for the <i>EndPoint</i> input variable to a motion control instruction is out of range.					
Source	PLC Function Module		Source details	Instruction	Detection timing	At instruction execution
Error attributes	Level	Observation	Recovery	---	Log category	System
Effects	User program	Continues.	Operation	The relevant instruction will end according to specifications.		
System-defined variables	Variable		Data type		Name	
	_MC_GRP[*].MFaultLvl.Active		BOOL		Axes Group Minor Fault Occurrence	
Cause and correction	Assumed cause		Correction		Prevention	
	The instruction input parameter exceeded the range of signed 40-bit data when it is converted to pulses.		Correct the parameter so that the valid range of the input variable is not exceeded for the relevant instruction.		Set the input parameter to the instruction so that the valid range of the input variable is not exceeded.	
Attached information	<p>Attached Information 1: Error Location</p> <p>Attached Information 2: Error Location Details (Rung Number). For a program section, the rung number from the start of the section is given. For ST, the line number is given.</p> <p>Attached Information 3: Names of the Instruction and Instruction Instance Where the Error Occurred. If there is more than one possible instruction, information is given on all of them. Nothing is given if the instruction cannot be identified.</p> <p>Attached Information 4: Expansion Error Code (<i>ErrorIDEx</i>)</p>					
Precautions/Remarks	If a program is changed after an error occurs, the attached information that is displayed may not be correct.					

Event name	Slave Travel Distance Specification Out of Range			Event code	5401548B hex	
Meaning	The parameter specified for the <i>SlaveDistance</i> input variable to a motion control instruction is out of range.					
Source	PLC Function Module		Source details	Instruction	Detection timing	At instruction execution
Error attributes	Level	Observation	Recovery	---	Log category	System
Effects	User program	Continues.	Operation	The relevant instruction will end according to specifications.		
System-defined variables	Variable		Data type		Name	
	_MC_AX[*].MFaultLvl.Active		BOOL		Axis Minor Fault Occurrence	
Cause and correction	Assumed cause		Correction		Prevention	
	The instruction input parameter exceeded the range of 40-bit data when it is converted to pulses.		Correct the parameter so that the valid range of the input variable is not exceeded for the relevant instruction.		Set the input parameter to the instruction so that the valid range of the input variable is not exceeded.	
Attached information	<p>Attached Information 1: Error Location</p> <p>Attached Information 2: Error Location Details (Rung Number). For a program section, the rung number from the start of the section is given. For ST, the line number is given.</p> <p>Attached Information 3: Names of the Instruction and Instruction Instance Where the Error Occurred. If there is more than one possible instruction, information is given on all of them. Nothing is given if the instruction cannot be identified.</p> <p>Attached Information 4: Expansion Error Code (<i>ErrorIDEx</i>)</p>					
Precautions/Remarks	If a program is changed after an error occurs, the attached information that is displayed may not be correct.					

Event name	Phase Shift Amount Out of Range			Event code	5401548C hex	
Meaning	The parameter specified for the <i>PhaseShift</i> input variable to a motion control instruction is out of range.					
Source	PLC Function Module		Source details	Instruction	Detection timing	At instruction execution
Error attributes	Level	Observation	Recovery	---	Log category	System
Effects	User program	Continues.	Operation	The relevant instruction will end according to specifications.		
System-defined variables	Variable		Data type		Name	
	_MC_AX[*].MFaultLvl.Active		BOOL		Axis Minor Fault Occurrence	
Cause and correction	Assumed cause		Correction		Prevention	
	The absolute value of the instruction input parameter exceeded the range of 40-bit data when it is converted to pulses.		Correct the parameter so that the valid range of the input variable is not exceeded for the relevant instruction.		Set the input parameter to the instruction so that the valid range of the input variable is not exceeded.	
Attached information	<p>Attached Information 1: Error Location</p> <p>Attached Information 2: Error Location Details (Rung Number). For a program section, the rung number from the start of the section is given. For ST, the line number is given.</p> <p>Attached Information 3: Names of the Instruction and Instruction Instance Where the Error Occurred. If there is more than one possible instruction, information is given on all of them. Nothing is given if the instruction cannot be identified.</p> <p>Attached Information 4: Expansion Error Code (<i>ErrorIDEx</i>)</p>					
Precautions/Remarks	If a program is changed after an error occurs, the attached information that is displayed may not be correct.					

Event name	Feeding Distance Out of Range			Event code	5401548D hex	
Meaning	The parameter specified for the <i>FeedDistance</i> input variable to a motion control instruction is out of range.					
Source	PLC Function Module		Source details	Instruction	Detection timing	At instruction execution
Error attributes	Level	Observation	Recovery	---	Log category	System
Effects	User program	Continues.	Operation	The relevant instruction will end according to specifications.		
System-defined variables	Variable		Data type		Name	
	_MC_AX[*].MFaultLvl.Active		BOOL		Axis Minor Fault Occurrence	
Cause and correction	Assumed cause		Correction		Prevention	
	The absolute value of the instruction input parameter exceeded the range of 40-bit data when it is converted to pulses.		Correct the parameter so that the valid range of the input variable is not exceeded for the relevant instruction.		Set the input parameter to the instruction so that the valid range of the input variable is not exceeded.	
Attached information	<p>Attached Information 1: Error Location</p> <p>Attached Information 2: Error Location Details (Rung Number). For a program section, the rung number from the start of the section is given. For ST, the line number is given.</p> <p>Attached Information 3: Names of the Instruction and Instruction Instance Where the Error Occurred. If there is more than one possible instruction, information is given on all of them. Nothing is given if the instruction cannot be identified.</p> <p>Attached Information 4: Expansion Error Code (<i>ErrorIDEx</i>)</p>					
Precautions/Remarks	If a program is changed after an error occurs, the attached information that is displayed may not be correct.					

Event name	Auxiliary and Slave Defined as Same Axis			Event code	5401548E hex	
Meaning	The same axis is specified for the <i>Auxiliary</i> and <i>Slave</i> input variables to a motion control instruction.					
Source	PLC Function Module		Source details	Instruction	Detection timing	At instruction execution
Error attributes	Level	Observation	Recovery	---	Log category	System
Effects	User program	Continues.	Operation	The relevant instruction will end according to specifications.		
System-defined variables	Variable		Data type		Name	
	_MC_AX[*].MFaultLvl.Active		BOOL		Axis Minor Fault Occurrence	
Cause and correction	Assumed cause		Correction		Prevention	
	The parameter was the same for the <i>Auxiliary</i> and <i>Slave</i> input variables to the instruction.		Correct the parameters so that different axes are specified for the <i>Auxiliary</i> and <i>Slave</i> input variables to the instruction.		Specify different axes for the auxiliary axis and slave axis for a motion control instruction.	
Attached information	<p>Attached Information 1: Error Location</p> <p>Attached Information 2: Error Location Details (Rung Number). For a program section, the rung number from the start of the section is given. For ST, the line number is given.</p> <p>Attached Information 3: Names of the Instruction and Instruction Instance Where the Error Occurred. If there is more than one possible instruction, information is given on all of them. Nothing is given if the instruction cannot be identified.</p> <p>Attached Information 4: Expansion Error Code (<i>ErrorIDEx</i>)</p>					
Precautions/Remarks	If a program is changed after an error occurs, the attached information that is displayed may not be correct.					

Event name	Relative Position Selection Out of Range			Event code	5401548F hex	
Meaning	The parameter specified for the <i>Relative</i> input variable to a motion control instruction is out of range.					
Source	PLC Function Module		Source details	Instruction	Detection timing	At instruction execution
Error attributes	Level	Observation	Recovery	---	Log category	System
Effects	User program	Continues.	Operation	The relevant instruction will end according to specifications.		
System-defined variables	Variable		Data type		Name	
	_MC_AX[*].MFaultLvl.Active		BOOL		Axis Minor Fault Occurrence	
Cause and correction	Assumed cause		Correction		Prevention	
	Instruction input parameter exceeded the valid range of the input variable.		Correct the parameter so that the valid range of the input variable is not exceeded for the relevant instruction.		Set the input parameter to the instruction so that the valid range of the input variable is not exceeded.	
Attached information	<p>Attached Information 1: Error Location</p> <p>Attached Information 2: Error Location Details (Rung Number). For a program section, the rung number from the start of the section is given. For ST, the line number is given.</p> <p>Attached Information 3: Names of the Instruction and Instruction Instance Where the Error Occurred. If there is more than one possible instruction, information is given on all of them. Nothing is given if the instruction cannot be identified.</p> <p>Attached Information 4: Expansion Error Code (<i>ErrorIDEx</i>)</p>					
Precautions/Remarks	If a program is changed after an error occurs, the attached information that is displayed may not be correct.					

Event name	Cam Transition Specification Out of Range		Event code	54015490 hex		
Meaning	The parameter specified for the <i>CamTransition</i> input variable to a motion control instruction is out of range.					
Source	PLC Function Module		Source details	Instruction	Detection timing	At instruction execution
Error attributes	Level	Observation	Recovery	---	Log category	System
Effects	User program	Continues.	Operation	The relevant instruction will end according to specifications.		
System-defined variables	Variable		Data type		Name	
	_MC_AX[*].MFaultLvl.Active		BOOL		Axis Minor Fault Occurrence	
Cause and correction	Assumed cause		Correction		Prevention	
	Instruction input parameter exceeded the valid range of the input variable.		Correct the parameter so that the valid range of the input variable is not exceeded for the relevant instruction.		Set the input parameter to the instruction so that the valid range of the input variable is not exceeded.	
Attached information	<p>Attached Information 1: Error Location</p> <p>Attached Information 2: Error Location Details (Rung Number). For a program section, the rung number from the start of the section is given. For ST, the line number is given.</p> <p>Attached Information 3: Names of the Instruction and Instruction Instance Where the Error Occurred. If there is more than one possible instruction, information is given on all of them. Nothing is given if the instruction cannot be identified.</p> <p>Attached Information 4: Expansion Error Code (<i>ErrorIDEx</i>)</p>					
Precautions/Remarks	If a program is changed after an error occurs, the attached information that is displayed may not be correct.					

Event name	Synchronized Control End Mode Selection Out of Range		Event code	54015491 hex		
Meaning	The parameter specified for the <i>OutMode</i> input variable to a motion control instruction is out of range.					
Source	PLC Function Module		Source details	Instruction	Detection timing	At instruction execution
Error attributes	Level	Observation	Recovery	---	Log category	System
Effects	User program	Continues.	Operation	The relevant instruction will end according to specifications.		
System-defined variables	Variable		Data type		Name	
	_MC_AX[*].MFaultLvl.Active		BOOL		Axis Minor Fault Occurrence	
Cause and correction	Assumed cause		Correction		Prevention	
	Instruction input parameter exceeded the valid range of the input variable.		Correct the parameter so that the valid range of the input variable is not exceeded for the relevant instruction.		Set the input parameter to the instruction so that the valid range of the input variable is not exceeded.	
Attached information	<p>Attached Information 1: Error Location</p> <p>Attached Information 2: Error Location Details (Rung Number). For a program section, the rung number from the start of the section is given. For ST, the line number is given.</p> <p>Attached Information 3: Names of the Instruction and Instruction Instance Where the Error Occurred. If there is more than one possible instruction, information is given on all of them. Nothing is given if the instruction cannot be identified.</p> <p>Attached Information 4: Expansion Error Code (<i>ErrorIDEx</i>)</p>					
Precautions/Remarks	If a program is changed after an error occurs, the attached information that is displayed may not be correct.					

Event name	Enable External Latch Instruction Execution Disabled		Event code	54015492 hex		
Meaning	_mclImmediateStop was specified for the StopMode input variable when the MC_TouchProbe (Enable External Latch) instruction was executed in Drive Mode for an encoder axis.					
Source	PLC Function Module		Source details	Instruction	Detection timing	At instruction execution
Error attributes	Level	Observation	Recovery	---	Log category	System
Effects	User program	Continues.	Operation	The relevant instruction will end according to specifications.		
System-defined variables	Variable		Data type		Name	
	_MC_AX[*].MFaultLvl.Active		BOOL		Axis Minor Fault Occurrence	
Cause and correction	Assumed cause		Correction		Prevention	
	_mclImmediateStop was specified for the StopMode input variable when the MC_TouchProbe (Enable External Latch) instruction was executed in Drive Mode for an encoder axis.		Correct the program so that _mclImmediateStop is not specified for StopMode for the encoder axis.		If you specify _mclImmediateStop and use Drive Mode, execute the MC_TouchProbe (Enable External Latch) instruction only for a servo axis.	
Attached information	<p>Attached Information 1: Error Location</p> <p>Attached Information 2: Error Location Details (Rung Number). For a program section, the rung number from the start of the section is given. For ST, the line number is given.</p> <p>Attached Information 3: Names of the Instruction and Instruction Instance Where the Error Occurred. If there is more than one possible instruction, information is given on all of them. Nothing is given if the instruction cannot be identified.</p> <p>Attached Information 4: Expansion Error Code (ErrorIDEx)</p>					
Precautions/Remarks	If a program is changed after an error occurs, the attached information that is displayed may not be correct.					

Event name	Master Axis Offset Out of Range		Event code	54015493 hex		
Meaning	The parameter specified for the MasterOffset input variable to a motion control instruction is out of range.					
Source	PLC Function Module		Source details	Instruction	Detection timing	At instruction execution
Error attributes	Level	Observation	Recovery	---	Log category	System
Effects	User program	Continues.	Operation	The relevant instruction will end according to specifications.		
System-defined variables	Variable		Data type		Name	
	_MC_AX[*].MFaultLvl.Active		BOOL		Axis Minor Fault Occurrence	
Cause and correction	Assumed cause		Correction		Prevention	
	The instruction input parameter exceeded the range of signed 40-bit data when it is converted to pulses.		Correct the parameter so that the valid range of the input variable is not exceeded for the relevant instruction.		Set the input parameter to the instruction so that the valid range of the input variable is not exceeded.	
Attached information	<p>Attached Information 1: Error Location</p> <p>Attached Information 2: Error Location Details (Rung Number). For a program section, the rung number from the start of the section is given. For ST, the line number is given.</p> <p>Attached Information 3: Names of the Instruction and Instruction Instance Where the Error Occurred. If there is more than one possible instruction, information is given on all of them. Nothing is given if the instruction cannot be identified.</p> <p>Attached Information 4: Expansion Error Code (ErrorIDEx)</p>					
Precautions/Remarks	If a program is changed after an error occurs, the attached information that is displayed may not be correct.					

Event name	Slave Axis Offset Out of Range			Event code	54015494 hex	
Meaning	The parameter specified for the <i>SlaveOffset</i> input variable to a motion control instruction is out of range.					
Source	PLC Function Module		Source details	Instruction	Detection timing	At instruction execution
Error attributes	Level	Observation	Recovery	---	Log category	System
Effects	User program	Continues.	Operation	The relevant instruction will end according to specifications.		
System-defined variables	Variable		Data type		Name	
	_MC_AX[*].MFAultLvl.Active		BOOL		Axis Minor Fault Occurrence	
Cause and correction	Assumed cause		Correction		Prevention	
	The instruction input parameter exceeded the range of signed 40-bit data when it is converted to pulses.		Correct the parameter so that the valid range of the input variable is not exceeded for the relevant instruction.		Set the input parameter to the instruction so that the valid range of the input variable is not exceeded.	
Attached information	<p>Attached Information 1: Error Location</p> <p>Attached Information 2: Error Location Details (Rung Number). For a program section, the rung number from the start of the section is given. For ST, the line number is given.</p> <p>Attached Information 3: Names of the Instruction and Instruction Instance Where the Error Occurred. If there is more than one possible instruction, information is given on all of them. Nothing is given if the instruction cannot be identified.</p> <p>Attached Information 4: Expansion Error Code (<i>ErrorIDEx</i>)</p>					
Precautions/Remarks	If a program is changed after an error occurs, the attached information that is displayed may not be correct.					

Event name	Command Current Position Count Selection Out of Range			Event code	54015495 hex	
Meaning	The parameter specified for the <i>CmdPosMode</i> input variable to a motion control instruction is out of range.					
Source	PLC Function Module		Source details	Instruction	Detection timing	At instruction execution
Error attributes	Level	Observation	Recovery	---	Log category	System
Effects	User program	Continues.	Operation	The relevant instruction will end according to specifications.		
System-defined variables	Variable		Data type		Name	
	_MC_AX[*].MFAultLvl.Active		BOOL		Axis Minor Fault Occurrence	
Cause and correction	Assumed cause		Correction		Prevention	
	Instruction input parameter exceeded the valid range of the input variable.		Correct the parameter so that the valid range of the input variable is not exceeded for the relevant instruction.		Set the input parameter to the instruction so that the valid range of the input variable is not exceeded.	
Attached information	<p>Attached Information 1: Error Location</p> <p>Attached Information 2: Error Location Details (Rung Number). For a program section, the rung number from the start of the section is given. For ST, the line number is given.</p> <p>Attached Information 3: Names of the Instruction and Instruction Instance Where the Error Occurred. If there is more than one possible instruction, information is given on all of them. Nothing is given if the instruction cannot be identified.</p> <p>Attached Information 4: Expansion Error Code (<i>ErrorIDEx</i>)</p>					
Precautions/Remarks	If a program is changed after an error occurs, the attached information that is displayed may not be correct.					

Event name	Master Axis Gear Ratio Numerator Out of Range		Event code	5401 5496 hex		
Meaning	The parameter specified for the <i>RatioNumeratorMaster</i> input variable to a motion control instruction is out of range.					
Source	PLC Function Module		Source details	Instruction	Detection timing	At instruction execution
Error attributes	Level	Observation	Recovery	---	Log category	System
Effects	User program	Continues.	Operation	The relevant instruction will end according to specifications.		
System-defined variables	Variable		Data type		Name	
	_MC_AX[*].MFAultLvl.Active		BOOL		Axis Minor Fault Occurrence	
Cause and correction	Assumed cause		Correction		Prevention	
	Instruction input parameter exceeded the valid range of the input variable.		Correct the parameter so that the valid range of the input variable is not exceeded for the relevant instruction.		Set the input parameter to the instruction so that the valid range of the input variable is not exceeded.	
Attached information	<p>Attached Information 1: Error Location</p> <p>Attached Information 2: Error Location Details (Rung Number). For a program section, the rung number from the start of the section is given. For ST, the line number is given.</p> <p>Attached Information 3: Names of the Instruction and Instruction Instance Where the Error Occurred. If there is more than one possible instruction, information is given on all of them. Nothing is given if the instruction cannot be identified.</p> <p>Attached Information 4: Expansion Error Code (<i>ErrorIDEx</i>)</p>					
Precautions/Remarks	If a program is changed after an error occurs, the attached information that is displayed may not be correct.					

Event name	Master Axis Gear Ratio Denominator Out of Range		Event code	5401 5497 hex		
Meaning	The parameter specified for the <i>RatioDenominatorMaster</i> input variable to a motion control instruction is out of range.					
Source	PLC Function Module		Source details	Instruction	Detection timing	At instruction execution
Error attributes	Level	Observation	Recovery	---	Log category	System
Effects	User program	Continues.	Operation	The relevant instruction will end according to specifications.		
System-defined variables	Variable		Data type		Name	
	_MC_AX[*].MFAultLvl.Active		BOOL		Axis Minor Fault Occurrence	
Cause and correction	Assumed cause		Correction		Prevention	
	Instruction input parameter exceeded the valid range of the input variable.		Correct the parameter so that the valid range of the input variable is not exceeded for the relevant instruction.		Set the input parameter to the instruction so that the valid range of the input variable is not exceeded.	
Attached information	<p>Attached Information 1: Error Location</p> <p>Attached Information 2: Error Location Details (Rung Number). For a program section, the rung number from the start of the section is given. For ST, the line number is given.</p> <p>Attached Information 3: Names of the Instruction and Instruction Instance Where the Error Occurred. If there is more than one possible instruction, information is given on all of them. Nothing is given if the instruction cannot be identified.</p> <p>Attached Information 4: Expansion Error Code (<i>ErrorIDEx</i>)</p>					
Precautions/Remarks	If a program is changed after an error occurs, the attached information that is displayed may not be correct.					

Event name	Auxiliary Axis Gear Ratio Numerator Out of Range		Event code	54015498 hex		
Meaning	The parameter specified for the <i>RatioNumeratorAuxiliary</i> input variable to a motion control instruction is out of range.					
Source	PLC Function Module		Source details	Instruction	Detection timing	At instruction execution
Error attributes	Level	Observation	Recovery	---	Log category	System
Effects	User program	Continues.	Operation	The relevant instruction will end according to specifications.		
System-defined variables	Variable		Data type		Name	
	_MC_AX[*].MFaultLvl.Active		BOOL		Axis Minor Fault Occurrence	
Cause and correction	Assumed cause		Correction		Prevention	
	Instruction input parameter exceeded the valid range of the input variable.		Correct the parameter so that the valid range of the input variable is not exceeded for the relevant instruction.		Set the input parameter to the instruction so that the valid range of the input variable is not exceeded.	
Attached information	<p>Attached Information 1: Error Location</p> <p>Attached Information 2: Error Location Details (Rung Number). For a program section, the rung number from the start of the section is given. For ST, the line number is given.</p> <p>Attached Information 3: Names of the Instruction and Instruction Instance Where the Error Occurred. If there is more than one possible instruction, information is given on all of them. Nothing is given if the instruction cannot be identified.</p> <p>Attached Information 4: Expansion Error Code (<i>ErrorIDEx</i>)</p>					
Precautions/Remarks	If a program is changed after an error occurs, the attached information that is displayed may not be correct.					

Event name	Auxiliary Axis Gear Ratio Denominator Out of Range		Event code	54015499 hex		
Meaning	The parameter specified for the <i>RatioDenominatorAuxiliary</i> input variable to a motion control instruction is out of range.					
Source	PLC Function Module		Source details	Instruction	Detection timing	At instruction execution
Error attributes	Level	Observation	Recovery	---	Log category	System
Effects	User program	Continues.	Operation	The relevant instruction will end according to specifications.		
System-defined variables	Variable		Data type		Name	
	_MC_AX[*].MFaultLvl.Active		BOOL		Axis Minor Fault Occurrence	
Cause and correction	Assumed cause		Correction		Prevention	
	Instruction input parameter exceeded the valid range of the input variable.		Correct the parameter so that the valid range of the input variable is not exceeded for the relevant instruction.		Set the input parameter to the instruction so that the valid range of the input variable is not exceeded.	
Attached information	<p>Attached Information 1: Error Location</p> <p>Attached Information 2: Error Location Details (Rung Number). For a program section, the rung number from the start of the section is given. For ST, the line number is given.</p> <p>Attached Information 3: Names of the Instruction and Instruction Instance Where the Error Occurred. If there is more than one possible instruction, information is given on all of them. Nothing is given if the instruction cannot be identified.</p> <p>Attached Information 4: Expansion Error Code (<i>ErrorIDEx</i>)</p>					
Precautions/Remarks	If a program is changed after an error occurs, the attached information that is displayed may not be correct.					

Event name	Master Axis Position Type Selection Out of Range		Event code	5401 549A hex		
Meaning	The parameter specified for the <i>ReferenceTypeMaster</i> input variable to a motion control instruction is out of range.					
Source	PLC Function Module		Source details	Instruction	Detection timing	At instruction execution
Error attributes	Level	Observation	Recovery	---	Log category	System
Effects	User program	Continues.	Operation	The relevant instruction will end according to specifications.		
System-defined variables	Variable		Data type		Name	
	_MC_AX[*].MFAultLvl.Active		BOOL		Axis Minor Fault Occurrence	
Cause and correction	Assumed cause		Correction		Prevention	
	Instruction input parameter exceeded the valid range of the input variable.		Correct the parameter so that the valid range of the input variable is not exceeded for the relevant instruction.		Set the input parameter to the instruction so that the valid range of the input variable is not exceeded.	
Attached information	<p>Attached Information 1: Error Location</p> <p>Attached Information 2: Error Location Details (Rung Number). For a program section, the rung number from the start of the section is given. For ST, the line number is given.</p> <p>Attached Information 3: Names of the Instruction and Instruction Instance Where the Error Occurred. If there is more than one possible instruction, information is given on all of them. Nothing is given if the instruction cannot be identified.</p> <p>Attached Information 4: Expansion Error Code (<i>ErrorIDEx</i>)</p>					
Precautions/Remarks	If a program is changed after an error occurs, the attached information that is displayed may not be correct.					

Event name	Auxiliary Axis Position Type Selection Out of Range		Event code	5401 549B hex		
Meaning	The parameter specified for the <i>ReferenceTypeAuxiliary</i> input variable to a motion control instruction is out of range.					
Source	PLC Function Module		Source details	Instruction	Detection timing	At instruction execution
Error attributes	Level	Observation	Recovery	---	Log category	System
Effects	User program	Continues.	Operation	The relevant instruction will end according to specifications.		
System-defined variables	Variable		Data type		Name	
	_MC_AX[*].MFAultLvl.Active		BOOL		Axis Minor Fault Occurrence	
Cause and correction	Assumed cause		Correction		Prevention	
	Instruction input parameter exceeded the valid range of the input variable.		Correct the parameter so that the valid range of the input variable is not exceeded for the relevant instruction.		Set the input parameter to the instruction so that the valid range of the input variable is not exceeded.	
Attached information	<p>Attached Information 1: Error Location</p> <p>Attached Information 2: Error Location Details (Rung Number). For a program section, the rung number from the start of the section is given. For ST, the line number is given.</p> <p>Attached Information 3: Names of the Instruction and Instruction Instance Where the Error Occurred. If there is more than one possible instruction, information is given on all of them. Nothing is given if the instruction cannot be identified.</p> <p>Attached Information 4: Expansion Error Code (<i>ErrorIDEx</i>)</p>					
Precautions/Remarks	If a program is changed after an error occurs, the attached information that is displayed may not be correct.					

Event name	Target Position Ring Counter Out of Range		Event code	5401549C hex		
Meaning	Operation is not possible because the target position is out of range for the ring counter of the executed instruction.					
Source	PLC Function Module		Source details	Instruction	Detection timing	At instruction execution
Error attributes	Level	Observation	Recovery	---	Log category	System
Effects	User program	Continues.	Operation	The relevant instruction will end according to specifications.		
System-defined variables	Variable		Data type		Name	
	_MC_AX[*].MFAultLvl.Active		BOOL		Axis Minor Fault Occurrence	
Cause and correction	Assumed cause		Correction		Prevention	
	High-speed homing was executed when 0 was not included in the ring counter.		High-speed homing cannot be executed when the ring counter range does not include 0. Correct the program so that high-speed homing is not performed. Or change the settings so that the ring counter range includes 0.		High-speed homing cannot be executed when the ring counter range does not include 0. Write the program so that high-speed homing is not performed. Or make the settings so that the ring counter range includes 0.	
Attached information	<p>Attached Information 1: Error Location</p> <p>Attached Information 2: Error Location Details (Rung Number). For a program section, the rung number from the start of the section is given. For ST, the line number is given.</p> <p>Attached Information 3: Names of the Instruction and Instruction Instance Where the Error Occurred. If there is more than one possible instruction, information is given on all of them. Nothing is given if the instruction cannot be identified.</p> <p>Attached Information 4: Expansion Error Code (<i>ErrorIDEx</i>)</p>					
Precautions/Remarks	If a program is changed after an error occurs, the attached information that is displayed may not be correct.					

Event name	Axes Group Composition Axis Setting Out of Range		Event code	5401549D hex*		
Meaning	The parameter specified for the Axes input variable to a motion control instruction is out of range.					
Source	PLC Function Module		Source details	Instruction	Detection timing	At instruction execution
Error attributes	Level	Observation	Recovery	---	Log category	System
Effects	User program	Continues.	Operation	The relevant instruction will end according to specifications.		
System-defined variables	Variable		Data type		Name	
	_MC_GRP[*].MFAultLvl.Active		BOOL		Axes Group Minor Fault Occurrence	
Cause and correction	Assumed cause		Correction		Prevention	
	Instruction input parameter exceeded the valid range of the input variable.		Correct the parameter so that the valid range of the input variable is not exceeded for the relevant instruction		Set the input parameter to the instruction so that the valid range of the input variable is not exceeded.	
	The composition axes in the axes group are not assigned to the same task.		Assign all of the axes that are specified for the Axes input variable to the instruction to the same task.		Specify axes that are assigned to the same task for all of the composition axes in an axes group.	
Attached information	<p>Attached Information 1: Error Location</p> <p>Attached Information 2: Error Location Details (Rung Number). For a program section, the rung number from the start of the section is given. For ST, the line number is given.</p> <p>Attached Information 3: Names of the Instruction and Instruction Instance Where the Error Occurred. If there is more than one possible instruction, information is given on all of them. Nothing is given if the instruction cannot be identified.</p> <p>Attached Information 4: Expansion Error Code (<i>ErrorIDEx</i>)</p>					
Precautions/Remarks	If a program is changed after an error occurs, the attached information that is displayed may not be correct.					

* Error code 16#549D occurs for unit version 1.01 or later of the CPU Unit.

Event name	Axis Use Setting Out of Range			Event code	5401549E hex*	
Meaning	The parameter specified for the <i>AxisUse</i> input variable to a motion control instruction is out of range.					
Source	PLC Function Module		Source details	Instruction	Detection timing	At instruction execution
Error attributes	Level	Observation	Recovery	---	Log category	System
Effects	User program	Continues.	Operation	The relevant instruction will end according to specifications.		
System-defined variables	Variable		Data type		Name	
	_MC_COM.MFaultLvl.Active		BOOL		MC Common Minor Fault Occurrence	
	_MC_AX[*].MFaultLvl.Active		BOOL		Axis Minor Fault Occurrence	
Cause and correction	Assumed cause		Correction		Prevention	
	Instruction input parameter exceeded the valid range of the input variable.		Correct the parameter so that the valid range of the input variable is not exceeded for the relevant instruction.		Set the input parameter to the instruction so that the valid range of the input variable is not exceeded.	
Attached information	<p>Attached Information 1: Error Location</p> <p>Attached Information 2: Error Location Details (Rung Number). For a program section, the rung number from the start of the section is given. For ST, the line number is given.</p> <p>Attached Information 3: Names of the Instruction and Instruction Instance Where the Error Occurred. If there is more than one possible instruction, information is given on all of them. Nothing is given if the instruction cannot be identified.</p> <p>Attached Information 4: Expansion Error Code (<i>ErrorIDEx</i>)</p>					
Precautions/Remarks	If a program is changed after an error occurs, the attached information that is displayed may not be correct.					

* Error code 16#549E occurs for unit version 1.04 or later of the CPU Unit.

Event name	Homing Parameter Setting Out of Range			Event code	54015700 hex*	
Meaning	The parameter specified for the <i>HomingParameter</i> input variable to a motion control instruction is out of range.					
Source	PLC Function Module		Source details	Instruction	Detection timing	At instruction execution
Error attributes	Level	Observation	Recovery	---	Log category	System
Effects	User program	Continues.	Operation	The relevant instruction will end according to specifications.		
System-defined variables	Variable		Data type		Name	
	_MC_COM.MFaultLvl.Active		BOOL		MC Common Minor Fault Occurrence	
Cause and correction	Assumed cause		Correction		Prevention	
	Instruction input parameter exceeded the valid range of the input variable.		Correct the parameter so that the valid range of the input variable is not exceeded for the relevant instruction.		Set the input parameter to the instruction so that the valid range of the input variable is not exceeded.	
Attached information	<p>Attached Information 1: Error Location</p> <p>Attached Information 2: Error Location Details (Rung Number). For a program section, the rung number from the start of the section is given. For ST, the line number is given.</p> <p>Attached Information 3: Names of the Instruction and Instruction Instance Where the Error Occurred. If there is more than one possible instruction, information is given on all of them. Nothing is given if the instruction cannot be identified.</p> <p>Attached Information 4: Expansion Error Code (<i>ErrorIDEx</i>)</p>					
Precautions/Remarks	If a program is changed after an error occurs, the attached information that is displayed may not be correct.					

* Error code 16#5700 occurs for unit version 1.03 or later of the CPU Unit.

Event name	Axis Use Change Error		Event code	54015702 hex*		
Meaning	The MC_ChangeAxisUse (Change Axis Use) instruction was executed when the axis was not stopped or when the command velocity of the axis was saturated.					
Source	PLC Function Module		Source details	Instruction	Detection timing	At instruction execution
Error attributes	Level	Observation	Recovery	---	Log category	System
Effects	User program	Continues.	Operation	The relevant instruction will end according to specifications.		
System-defined variables	Variable		Data type		Name	
	_MC_AX[*].MFAultLvl.Active		BOOL		Axis Minor Fault Occurrence	
Cause and correction	Assumed cause		Correction		Prevention	
	The MC_ChangeAxisUse (Change Axis Use) instruction was executed when the axis was not stopped or when the command velocity of the axis was saturated.		Reset the error and execute the MC_ChangeAxisUse (Change Axis Use) instruction when the axis is stopped or when the command velocity of the axis is not saturated. An axis is stopped if <i>Status.Disabled</i> or <i>Status.Standstill</i> is TRUE in the Axis Variable. The command velocity for an axis is saturated if <i>Details.Vel-Limit</i> is TRUE in the Axis Variable.		Execute the MC_ChangeAxisUse (Change Axis Use) instruction when the axis is stopped and the command velocity is not saturated.	
Attached information	Attached Information 1: Error Location Attached Information 2: Error Location Details (Rung Number). For a program section, the rung number from the start of the section is given. For ST, the line number is given. Attached Information 3: Names of the Instruction and Instruction Instance Where the Error Occurred. If there is more than one possible instruction, information is given on all of them. Nothing is given if the instruction cannot be identified. Attached Information 4: Expansion Error Code (<i>ErrorIDEx</i>)					
Precautions/Remarks	If a program is changed after an error occurs, the attached information that is displayed may not be correct.					

* Error code 16#5702 occurs for unit version 1.04 or later of the CPU Unit.

Event name	Cannot Change Axis Use		Event code	54015703 hex*		
Meaning	The MC_ChangeAxisUse (Change Axis Use) instruction was executed in a way that would cause the maximum number of used real axes or the maximum number of used motion control servo axes to be exceeded.					
Source	PLC Function Module		Source details	Instruction	Detection timing	At instruction execution
Error attributes	Level	Observation	Recovery	---	Log category	System
Effects	User program	Continues.	Operation	The relevant instruction will end according to specifications.		
System-defined variables	Variable		Data type		Name	
	_MC_COM.MFaultLvl.Active		BOOL		MC Common Minor Fault Occurrence	
Cause and correction	Assumed cause		Correction		Prevention	
	The MC_ChangeAxisUse (Change Axis Use) instruction was executed in a way that would cause the maximum number of actually usable axes to be exceeded.		Correct the program so that the maximum number of axes that can actually be used by the CPU Unit is not exceeded.		Write the program so that the maximum number of axes that can actually be used by the CPU Unit is not exceeded.	
	The MC_ChangeAxisUse (Change Axis Use) instruction was executed in a way that would cause the maximum number of used motion control servo axes to be exceeded.		Correct the program so that the maximum number of used motion control servo axes that can be used by the CPU Unit is not exceeded.		Write the program so that the maximum number of used motion control servo axes that can be used by the CPU Unit is not exceeded.	
Attached information	<p>Attached Information 1: Error Location</p> <p>Attached Information 2: Error Location Details (Rung Number). For a program section, the rung number from the start of the section is given. For ST, the line number is given.</p> <p>Attached Information 3: Names of the Instruction and Instruction Instance Where the Error Occurred. If there is more than one possible instruction, information is given on all of them. Nothing is given if the instruction cannot be identified.</p> <p>Attached Information 4: Expansion Error Code (<i>ErrorIDEx</i>)</p>					
Precautions/Remarks	If a program is changed after an error occurs, the attached information that is displayed may not be correct.					

* Error code 16#5703 occurs for unit version 1.06 or later of the CPU Unit.

Event name	Motion Control Parameter Setting Error When Changing Axis Use		Event code	54015720 hex*		
Meaning	The motion control parameter settings for the axis that was changed to a used axis are incorrect.					
Source	PLC Function Module		Source details	Instruction	Detection timing	At instruction execution
Error attributes	Level	Observation	Recovery	---	Log category	System
Effects	User program	Continues.	Operation	The relevant instruction will end according to specifications.		
System-defined variables	Variable		Data type		Name	
	_MC_COM.MFaultLvl.Active		BOOL		MC Common Minor Fault Occurrence	
Cause and correction	Assumed cause		Correction		Prevention	
	The MC_ChangeAxisUse (Change Axis Use) instruction was used to change an unused axis to a used axis, but the motion control parameter settings of the axis are not correct.		Use the Sysmac Studio to change the Axis Use of the axis where the error occurred to a Used Axis, and then check and correct the error location. If an error does not occur, change the setting to an Unused Axis and then download the settings again.		Make sure that operation is correct when the axis is set to a Used Axis and then download the settings with it set to an Unused Axis.	
	The power supply was interrupted while a download of the motion control parameter settings was in progress.		Download the MC parameters from the Sysmac Studio.		Do not interrupt the power supply while saving the parameter settings.	
	The non-volatile memory is faulty or the life of the non-volatile memory has been exceeded.		If this error remains even after making the above corrections, replace the CPU Unit.		None	
Attached information	<p>Attached Information 1: Error Location</p> <p>Attached Information 2: Error Location Details (Rung Number). For a program section, the rung number from the start of the section is given. For ST, the line number is given.</p> <p>Attached Information 3: Names of the Instruction and Instruction Instance Where the Error Occurred. If there is more than one possible instruction, information is given on all of them. Nothing is given if the instruction cannot be identified.</p> <p>Attached Information 4: Expansion Error Code (<i>ErrorIDEx</i>)</p>					
Precautions/Remarks	If a program is changed after an error occurs, the attached information that is displayed may not be correct.					

* Error code 16#5720 occurs for unit version 1.04 or later of the CPU Unit.

Event name	Required Process Data Object Not Set When Changing Axis Use		Event code	54015721 hex*		
Meaning	The objects that are required for the axis type of the axis that was changed to a used axis are not set.					
Source	PLC Function Module		Source details	Instruction	Detection timing	At instruction execution
Error attributes	Level	Observation	Recovery	---	Log category	System
Effects	User program	Continues.	Operation	The relevant instruction will end according to specifications.		
System-defined variables	Variable		Data type		Name	
	_MC_COM.MFaultLvl.Active		BOOL		MC Common Minor Fault Occurrence	
Cause and correction	Assumed cause		Correction		Prevention	
	The objects that are required for the axis type of the axis that was changed to a used axis are not set in the PDO map settings.		Edit the PDO map settings on the Sysmac Studio and set the objects that are required for the axis where the error occurred. For details on the required objects, refer to the <i>NJ/NX-series Motion Control Instructions Reference Manual</i> (Cat. No. W508).		Make sure that operation is correct when the axis is set to a Used Axis and then download the settings with it set to an Unused Axis.	
	The power supply was interrupted while a download of the motion control parameter settings was in progress.		Download the MC parameters from the Sysmac Studio.		Do not interrupt the power supply while saving the parameter settings.	
	The non-volatile memory is faulty or the life of the non-volatile memory has been exceeded.		If this error remains even after making the above corrections, replace the CPU Unit.		None	
	The MC_ChangeAxisUse (Change Axis Use) instruction was executed for an axis that is set to <i>Unused axis (unchangeable to used axis)</i> .		Correct the program so that the MC_ChangeAxisUse (Change Axis Use) instruction is not executed for an axis that is set to <i>Unused axis (unchangeable to used axis)</i> .		Write the program so that the MC_ChangeAxisUse (Change Axis Use) instruction is not executed for an axis that is set to <i>Unused axis (unchangeable to used axis)</i> .	
Attached information	<p>Attached Information 1: Error Location</p> <p>Attached Information 2: Error Location Details (Rung Number). For a program section, the rung number from the start of the section is given. For ST, the line number is given.</p> <p>Attached Information 3: Names of the Instruction and Instruction Instance Where the Error Occurred. If there is more than one possible instruction, information is given on all of them. Nothing is given if the instruction cannot be identified.</p> <p>Attached Information 4: Expansion Error Code (<i>ErrorIDEx</i>)</p>					
Precautions/Remarks	If a program is changed after an error occurs, the attached information that is displayed may not be correct.					

* Error code 16#5721 occurs for unit version 1.04 or later of the CPU Unit.

Event name	Actual Position Overflow/Underflow		Event code	54015722 hex*		
Meaning	An instruction was executed that is not supported during an actual position overflow/underflow.					
Source	PLC Function Module		Source details	Instruction	Detection timing	At instruction execution
Error attributes	Level	Observation	Recovery	---	Log category	System
Effects	User program	Continues.	Operation	The relevant instruction will end according to specifications.		
System-defined variables	Variable		Data type		Name	
	_MC_AX[*].Obsr.Active		BOOL		Axis Observation Occurrence	
Cause and correction	Assumed cause		Correction		Prevention	
	An instruction was executed that is not supported during an actual position overflow or underflow.		Execute an error reset and then clear the overflow or underflow state by changing the current position or homing.		Write the program so that overflows and underflows do not occur.	
Attached information	<p>Attached Information 1: Error Location</p> <p>Attached Information 2: Error Location Details (Rung Number). For a program section, the rung number from the start of the section is given. For ST, the line number is given.</p> <p>Attached Information 3: Name of the Instruction and Instruction Instance Where the Error Occurred. If there is more than one possible instruction, information is given on all of them. Nothing is given if the instruction cannot be identified.</p> <p>Attached Information 4: Expansion Error Code (<i>ErrorIDEx</i>)</p>					
Precautions/Remarks	If a program is changed after an error occurs, the attached information that is displayed may not be correct.					

* Error code 16#5722 occurs for unit version 1.06 or later of the CPU Unit.

Event name	Switch Structure Track Number Setting Out of Range		Event code	54015723 hex*		
Meaning	The value of <i>TrackNumber</i> that is specified in the <i>Switches</i> in-out variable to a motion control instruction is out of range.					
Source	PLC Function Module		Source details	Instruction	Detection timing	At instruction execution
Error attributes	Level	Observation	Recovery	---	Log category	System
Effects	User program	Continues.	Operation	The relevant instruction will end according to specifications.		
System-defined variables	Variable		Data type		Name	
	_MC_AX[*].Obsr.Active		BOOL		Axis Observation Occurrence	
Cause and correction	Assumed cause		Correction		Prevention	
	The value of the member of the structure variable that was specified for the in-out variable of the instruction is out of range.		Correct the value of the member of the structure variable that is specified for the in-out variable of the relevant instruction so that it is in the valid range.		Make sure that the value of the member of the structure variable that is specified for the in-out variable of the relevant instruction is in the valid range.	
Attached information	<p>Attached Information 1: Error Location</p> <p>Attached Information 2: Error Location Details (Rung Number). For a program section, the rung number from the start of the section is given. For ST, the line number is given.</p> <p>Attached Information 3: Name of the Instruction and Instruction Instance Where the Error Occurred. If there is more than one possible instruction, information is given on all of them. Nothing is given if the instruction cannot be identified.</p> <p>Attached Information 4: Expansion Error Code (<i>ErrorIDEx</i>)</p>					
Precautions/Remarks	If a program is changed after an error occurs, the attached information that is displayed may not be correct.					

* Error code 16#5723 occurs for unit version 1.06 or later of the CPU Unit.



Event name	Switch Structure First ON Position Setting Out of Range		Event code	54015724 hex*		
Meaning	The value of <i>FirstOnPosition</i> that is specified in the <i>Switches</i> in-out variable to a motion control instruction is out of range.					
Source	PLC Function Module		Source details	Instruction	Detection timing	At instruction execution
Error attributes	Level	Observation	Recovery	---	Log category	System
Effects	User program	Continues.	Operation	The relevant instruction will end according to specifications.		
System-defined variables	Variable		Data type		Name	
	_MC_AX[*].Obsr.Active		BOOL		Axis Observation Occurrence	
Cause and correction	Assumed cause		Correction		Prevention	
	The value of the member of the structure variable that was specified for the in-out variable of the instruction is out of range.		Correct the value of the member of the structure variable that is specified for the in-out variable of the relevant instruction so that it is in the valid range.		Make sure that the value of the member of the structure variable that is specified for the in-out variable of the relevant instruction is in the valid range.	
Attached information	Attached Information 1: Error Location Attached Information 2: Error Location Details (Rung Number). For a program section, the rung number from the start of the section is given. For ST, the line number is given. Attached Information 3: Name of the Instruction and Instruction Instance Where the Error Occurred. If there is more than one possible instruction, information is given on all of them. Nothing is given if the instruction cannot be identified. Attached Information 4: Expansion Error Code (<i>ErrorIDEx</i>)					
Precautions/Remarks	If a program is changed after an error occurs, the attached information that is displayed may not be correct.					

* Error code 16#5724 occurs for unit version 1.06 or later of the CPU Unit.

Event name	Switch Structure Last ON Position Setting Out of Range		Event code	54015725 hex*		
Meaning	The value of <i>LastOnPosition</i> that is specified in the <i>Switches</i> in-out variable to a motion control instruction is out of range.					
Source	PLC Function Module		Source details	Instruction	Detection timing	At instruction execution
Error attributes	Level	Observation	Recovery	---	Log category	System
Effects	User program	Continues.	Operation	The relevant instruction will end according to specifications.		
System-defined variables	Variable		Data type		Name	
	_MC_AX[*].Obsr.Active		BOOL		Axis Observation Occurrence	
Cause and correction	Assumed cause		Correction		Prevention	
	The value of the member of the structure variable that was specified for the in-out variable of the instruction is out of range.		Correct the value of the member of the structure variable that is specified for the in-out variable of the relevant instruction so that it is in the valid range.		Make sure that the value of the member of the structure variable that is specified for the in-out variable of the relevant instruction is in the valid range.	
Attached information	Attached Information 1: Error Location Attached Information 2: Error Location Details (Rung Number). For a program section, the rung number from the start of the section is given. For ST, the line number is given. Attached Information 3: Name of the Instruction and Instruction Instance Where the Error Occurred If there is more than one possible instruction, information is given on all of them. Nothing is given if the instruction cannot be identified. Attached Information 4: Expansion Error Code (<i>ErrorIDEx</i>)					
Precautions/Remarks	If a program is changed after an error occurs, the attached information that is displayed may not be correct.					

* Error code 16#5725 occurs for unit version 1.06 or later of the CPU Unit.

Event name	Switch Structure Axis Direction Out of Range		Event code	54015726 hex*		
Meaning	The value of <i>AxisDirection</i> that is specified in the <i>Switches</i> in-out variable to a motion control instruction is out of range.					
Source	PLC Function Module		Source details	Instruction	Detection timing	At instruction execution
Error attributes	Level	Observation	Recovery	---	Log category	System
Effects	User program	Continues.	Operation	The relevant instruction will end according to specifications.		
System-defined variables	Variable		Data type		Name	
	_MC_AX[*].Obsr.Active		BOOL		Axis Observation Occurrence	
Cause and correction	Assumed cause		Correction		Prevention	
	The value of the member of the structure variable that was specified for the in-out variable of the instruction is out of range.		Correct the value of the member of the structure variable that is specified for the in-out variable of the relevant instruction so that it is in the valid range.		Make sure that the value of the member of the structure variable that is specified for the in-out variable of the relevant instruction is in the valid range.	
Attached information	<p>Attached Information 1: Error Location</p> <p>Attached Information 2: Error Location Details (Rung Number). For a program section, the rung number from the start of the section is given. For ST, the line number is given.</p> <p>Attached Information 3: Name of the Instruction and Instruction Instance Where the Error Occurred. If there is more than one possible instruction, information is given on all of them. Nothing is given if the instruction cannot be identified.</p> <p>Attached Information 4: Expansion Error Code (<i>ErrorIDEx</i>)</p>					
Precautions/Remarks	If a program is changed after an error occurs, the attached information that is displayed may not be correct.					

* Error code 16#5726 occurs for unit version 1.06 or later of the CPU Unit.

Event name	Switch Structure Cam Switch Mode Out of Range		Event code	54015727 hex*		
Meaning	The value of <i>CamSwitchMode</i> that is specified in the <i>Switches</i> in-out variable to a motion control instruction is out of range.					
Source	PLC Function Module		Source details	Instruction	Detection timing	At instruction execution
Error attributes	Level	Observation	Recovery	---	Log category	System
Effects	User program	Continues.	Operation	The relevant instruction will end according to specifications.		
System-defined variables	Variable		Data type		Name	
	_MC_AX[*].Obsr.Active		BOOL		Axis Observation Occurrence	
Cause and correction	Assumed cause		Correction		Prevention	
	The value of the member of the structure variable that was specified for the in-out variable of the instruction is out of range.		Correct the value of the member of the structure variable that is specified for the in-out variable of the relevant instruction so that it is in the valid range.		Make sure that the value of the member of the structure variable that is specified for the in-out variable of the relevant instruction is in the valid range.	
Attached information	<p>Attached Information 1: Error Location</p> <p>Attached Information 2: Error Location Details (Rung Number). For a program section, the rung number from the start of the section is given. For ST, the line number is given.</p> <p>Attached Information 3: Name of the Instruction and Instruction Instance Where the Error Occurred If there is more than one possible instruction, information is given on all of them. Nothing is given if the instruction cannot be identified.</p> <p>Attached Information 4: Expansion Error Code (<i>ErrorIDEx</i>)</p>					
Precautions/Remarks	If a program is changed after an error occurs, the attached information that is displayed may not be correct.					

* Error code 16#5727 occurs for unit version 1.06 or later of the CPU Unit.

Event name	Switch Structure Duration Setting Out of Range		Event code	54015728 hex*		
Meaning	The value of <i>Duration</i> that is specified in the <i>Switches</i> in-out variable to a motion control instruction is out of range.					
Source	PLC Function Module		Source details	Instruction	Detection timing	At instruction execution
Error attributes	Level	Observation	Recovery	---	Log category	System
Effects	User program	Continues.	Operation	The relevant instruction will end according to specifications.		
System-defined variables	Variable		Data type		Name	
	_MC_AX[*].Obsr.Active		BOOL		Axis Observation Occurrence	
Cause and correction	Assumed cause		Correction		Prevention	
	The value of the member of the structure variable that was specified for the in-out variable of the instruction is out of range.		Correct the value of the member of the structure variable that is specified for the in-out variable of the relevant instruction so that it is in the valid range.		Make sure that the value of the member of the structure variable that is specified for the in-out variable of the relevant instruction is in the valid range.	
Attached information	<p>Attached Information 1: Error Location</p> <p>Attached Information 2: Error Location Details (Rung Number). For a program section, the rung number from the start of the section is given. For ST, the line number is given.</p> <p>Attached Information 3: Name of the Instruction and Instruction Instance Where the Error Occurred. If there is more than one possible instruction, information is given on all of them. Nothing is given if the instruction cannot be identified.</p> <p>Attached Information 4: Expansion Error Code (<i>ErrorIDEx</i>)</p>					
Precautions/Remarks	If a program is changed after an error occurs, the attached information that is displayed may not be correct.					

* Error code 16#5728 occurs for unit version 1.06 or later of the CPU Unit.

Event name	Track Option Structure ON Compensation Setting Out of Range		Event code	54015729 hex*		
Meaning	The value of <i>OnCompensation</i> that is specified in the <i>TrackOptions</i> in-out variable to a motion control instruction is out of range.					
Source	PLC Function Module		Source details	Instruction	Detection timing	At instruction execution
Error attributes	Level	Observation	Recovery	---	Log category	System
Effects	User program	Continues.	Operation	The relevant instruction will end according to specifications.		
System-defined variables	Variable		Data type		Name	
	_MC_AX[*].Obsr.Active		BOOL		Axis Observation Occurrence	
Cause and correction	Assumed cause		Correction		Prevention	
	The value of the member of the structure variable that was specified for the in-out variable of the instruction is out of range.		Correct the value of the member of the structure variable that is specified for the in-out variable of the relevant instruction so that it is in the valid range.		Make sure that the value of the member of the structure variable that is specified for the in-out variable of the relevant instruction is in the valid range.	
Attached information	<p>Attached Information 1: Error Location</p> <p>Attached Information 2: Error Location Details (Rung Number). For a program section, the rung number from the start of the section is given. For ST, the line number is given.</p> <p>Attached Information 3: Name of the Instruction and Instruction Instance Where the Error Occurred. If there is more than one possible instruction, information is given on all of them. Nothing is given if the instruction cannot be identified.</p> <p>Attached Information 4: Expansion Error Code (<i>ErrorIDEx</i>)</p>					
Precautions/Remarks	If a program is changed after an error occurs, the attached information that is displayed may not be correct.					

* Error code 16#5729 occurs for unit version 1.06 or later of the CPU Unit.

Event name	Track Option Structure OFF Compensation Setting Out of Range		Event code	5401572A hex*		
Meaning	The value of <i>OffCompensation</i> that is specified in the <i>TrackOptions</i> in-out variable to a motion control instruction is out of range.					
Source	PLC Function Module		Source details	Instruction	Detection timing	At instruction execution
Error attributes	Level	Observation	Recovery	---	Log category	System
Effects	User program	Continues.	Operation	The relevant instruction will end according to specifications.		
System-defined variables	Variable		Data type		Name	
	_MC_AX[*].Obsr.Active		BOOL		Axis Observation Occurrence	
Cause and correction	Assumed cause		Correction		Prevention	
	The value of the member of the structure variable that was specified for the in-out variable of the instruction is out of range.		Correct the value of the member of the structure variable that is specified for the in-out variable of the relevant instruction so that it is in the valid range.		Make sure that the value of the member of the structure variable that is specified for the in-out variable of the relevant instruction is in the valid range.	
Attached information	<p>Attached Information 1: Error Location</p> <p>Attached Information 2: Error Location Details (Rung Number). For a program section, the rung number from the start of the section is given. For ST, the line number is given.</p> <p>Attached Information 3: Name of the Instruction and Instruction Instance Where the Error Occurred. If there is more than one possible instruction, information is given on all of them. Nothing is given if the instruction cannot be identified.</p> <p>Attached Information 4: Expansion Error Code (<i>ErrorIDEx</i>)</p>					
Precautions/Remarks	If a program is changed after an error occurs, the attached information that is displayed may not be correct.					

* Error code 16#572A occurs for unit version 1.06 or later of the CPU Unit.

Event name	Number of Array Elements in Switch Structure Variable Out of Range		Event code	5401572B hex*		
Meaning	The number of elements in an array in the structure variable that is specified in the <i>Switches</i> in-out variable to a motion control instruction is out of range.					
Source	PLC Function Module		Source details	Instruction	Detection timing	At instruction execution
Error attributes	Level	Observation	Recovery	---	Log category	System
Effects	User program	Continues.	Operation	The relevant instruction will end according to specifications.		
System-defined variables	Variable		Data type		Name	
	_MC_AX[*].Obsr.Active		BOOL		Axis Observation Occurrence	
Cause and correction	Assumed cause		Correction		Prevention	
	The number of elements in an array of the structure variable that was specified for the in-out variable of the instruction is out of range.		Correct the number of elements in the array in the structure variable that is specified for the in-out variable of the relevant instruction so that it is in the valid range.		Make sure that the number of elements in the array in the structure variable that is specified for the in-out variable of the relevant instruction is in the valid range.	
Attached information	<p>Attached Information 1: Error Location</p> <p>Attached Information 2: Error Location Details (Rung Number). For a program section, the rung number from the start of the section is given. For ST, the line number is given.</p> <p>Attached Information 3: Name of the Instruction and Instruction Instance Where the Error Occurred. If there is more than one possible instruction, information is given on all of them. Nothing is given if the instruction cannot be identified.</p> <p>Attached Information 4: Expansion Error Code (<i>ErrorIDEx</i>)</p>					
Precautions/Remarks	If a program is changed after an error occurs, the attached information that is displayed may not be correct.					

* Error code 16#572B occurs for unit version 1.06 or later of the CPU Unit.

Event name	Number of Array Elements in Output Signal Structure Variable Out of Range		Event code	5401572C hex*		
Meaning	The number of elements in an array in the structure variable that is specified in the <i>Outputs</i> in-out variable to a motion control instruction is out of range.					
Source	PLC Function Module		Source details	Instruction	Detection timing	At instruction execution
Error attributes	Level	Observation	Recovery	---	Log category	System
Effects	User program	Continues.	Operation	The relevant instruction will end according to specifications.		
System-defined variables	Variable		Data type		Name	
	_MC_AX[*].Obsr.Active		BOOL		Axis Observation Occurrence	
Cause and correction	Assumed cause		Correction		Prevention	
	The number of elements in an array of the structure variable that was specified for the in-out variable of the instruction is out of range.		Correct the number of elements in the array in the structure variable that is specified for the in-out variable of the relevant instruction so that it is in the valid range.		Make sure that the number of elements in the array in the structure variable that is specified for the in-out variable of the relevant instruction is in the valid range.	
Attached information	<p>Attached Information 1: Error Location</p> <p>Attached Information 2: Error Location Details (Rung Number). For a program section, the rung number from the start of the section is given. For ST, the line number is given.</p> <p>Attached Information 3: Name of the Instruction and Instruction Instance Where the Error Occurred. If there is more than one possible instruction, information is given on all of them. Nothing is given if the instruction cannot be identified.</p> <p>Attached Information 4: Expansion Error Code (<i>ErrorIDEx</i>)</p>					
Precautions/Remarks	If a program is changed after an error occurs, the attached information that is displayed may not be correct.					

* Error code 16#572C occurs for unit version 1.06 or later of the CPU Unit.

Event name	Number of Array Elements in Track Option Structure Variable Out of Range		Event code	5401572D hex*		
Meaning	The number of elements in an array in the structure variable that is specified in the <i>TrackOptions</i> in-out variable to a motion control instruction is out of range.					
Source	PLC Function Module		Source details	Instruction	Detection timing	At instruction execution
Error attributes	Level	Observation	Recovery	---	Log category	System
Effects	User program	Continues.	Operation	The relevant instruction will end according to specifications.		
System-defined variables	Variable		Data type		Name	
	_MC_AX[*].Obsr.Active		BOOL		Axis Observation Occurrence	
Cause and correction	Assumed cause		Correction		Prevention	
	The number of elements in an array of the structure variable that was specified for the in-out variable of the instruction is out of range.		Correct the number of elements in the array in the structure variable that is specified for the in-out variable of the relevant instruction so that it is in the valid range.		Make sure that the number of elements in the array in the structure variable that is specified for the in-out variable of the relevant instruction is in the valid range.	
Attached information	<p>Attached Information 1: Error Location</p> <p>Attached Information 2: Error Location Details (Rung Number). For a program section, the rung number from the start of the section is given. For ST, the line number is given.</p> <p>Attached Information 3: Name of the Instruction and Instruction Instance Where the Error Occurred. If there is more than one possible instruction, information is given on all of them. Nothing is given if the instruction cannot be identified.</p> <p>Attached Information 4: Expansion Error Code (<i>ErrorIDEx</i>)</p>					
Precautions/Remarks	If a program is changed after an error occurs, the attached information that is displayed may not be correct.					

* Error code 16#572D occurs for unit version 1.06 or later of the CPU Unit.

Event name	Numbers of Elements in Output Signals and Track Option Arrays Not Matched		Event code	5401572E hex*		
Meaning	The arrays in the structure variables that are specified for the <i>Outputs</i> and <i>TrackOptions</i> in-out variables to a motion control instruction do not have the same number of elements.					
Source	PLC Function Module		Source details	Instruction	Detection timing	At instruction execution
Error attributes	Level	Observation	Recovery	---	Log category	System
Effects	User program	Continues.	Operation	The relevant instruction will end according to specifications.		
System-defined variables	Variable		Data type		Name	
	_MC_AX[*].Obsr.Active		BOOL		Axis Observation Occurrence	
Cause and correction	Assumed cause		Correction		Prevention	
	The arrays in the output signal structure variable and track option structure variable that are specified for the in-out variables to the instruction do not have the same number of elements.		Correct the output signal structure variable and track option structure variable that are specified for the in-out variables to the relevant instruction so that the arrays in them have the same number of elements.		Make sure that the arrays in the output signal structure variable and track option structure variable that are specified for the in-out variables to the relevant instruction have the same number of elements.	
Attached information	<p>Attached Information 1: Error Location</p> <p>Attached Information 2: Error Location Details (Rung Number). For a program section, the rung number from the start of the section is given. For ST, the line number is given.</p> <p>Attached Information 3: Name of the Instruction and Instruction Instance Where the Error Occurred. If there is more than one possible instruction, information is given on all of them. Nothing is given if the instruction cannot be identified.</p> <p>Attached Information 4: Expansion Error Code (<i>ErrorIDEx</i>)</p>					
Precautions/Remarks	If a program is changed after an error occurs, the attached information that is displayed may not be correct.					

* Error code 16#572E occurs for unit version 1.06 or later of the CPU Unit.

Event name	Motion Control Instruction Multi-execution Disabled (Master Axis)		Event code	5401572F hex*		
Meaning	A <i>Master</i> in-out variable that cannot be changed during multi-execution of instructions was changed.					
Source	PLC Function Module		Source details	Instruction	Detection timing	At instruction execution
Error attributes	Level	Observation	Recovery	---	Log category	System
Effects	User program	Continues.	Operation	The relevant instruction will end according to specifications.		
System-defined variables	Variable		Data type		Name	
	_MC_AX[*].MFaultLvl.Active		BOOL		Axis Minor Fault Occurrence	
Cause and correction	Assumed cause		Correction		Prevention	
	A <i>Master</i> in-out variable that cannot be changed during multi-execution of instructions was changed.		Correct the program so that the value of the <i>Master</i> in-out variable is not changed during multi-execution of the relevant instructions.		Write the program so that the value of the <i>Master</i> in-out variable is not changed during multi-execution of the relevant instructions.	
Attached information	<p>Attached Information 1: Error Location</p> <p>Attached Information 2: Error Location Details (Rung Number). For a program section, the rung number from the start of the section is given. For ST, the line number is given.</p> <p>Attached Information 3: Name of the Instruction and Instruction Instance Where the Error Occurred If there is more than one possible instruction, information is given on all of them. Nothing is given if the instruction cannot be identified.</p> <p>Attached Information 4: Expansion Error Code (<i>ErrorIDEx</i>)</p>					
Precautions/Remarks	If a program is changed after an error occurs, the attached information that is displayed may not be correct.					

* Error code 16#572F occurs for unit version 1.06 or later of the CPU Unit.

Event name	Motion Control Instruction Multi-execution Disabled (Position Type Selection)		Event code	54015730 hex*		
Meaning	A <i>ReferenceType</i> in-out variable that cannot be changed during multi-execution of instructions was changed.					
Source	PLC Function Module		Source details	Instruction	Detection timing	At instruction execution
Error attributes	Level	Observation	Recovery	---	Log category	System
Effects	User program	Continues.	Operation	The relevant instruction will end according to specifications.		
System-defined variables	Variable		Data type		Name	
	_MC_AX[*].MFaultLvl.Active		BOOL		Axis Minor Fault Occurrence	
Cause and correction	Assumed cause		Correction		Prevention	
	A <i>ReferenceType</i> in-out variable that cannot be changed during multi-execution of instructions was changed.		Correct the program so that the value of the <i>ReferenceType</i> in-out variable is not changed during multi-execution of the relevant instructions.		Write the program so that the value of the <i>ReferenceType</i> in-out variable is not changed during multi-execution of the relevant instructions.	
Attached information	<p>Attached Information 1: Error Location</p> <p>Attached Information 2: Error Location Details (Rung Number). For a program section, the rung number from the start of the section is given. For ST, the line number is given.</p> <p>Attached Information 3: Name of the Instruction and Instruction Instance Where the Error Occurred If there is more than one possible instruction, information is given on all of them. Nothing is given if the instruction cannot be identified.</p> <p>Attached Information 4: Expansion Error Code (<i>ErrorIDEx</i>)</p>					
Precautions/Remarks	If a program is changed after an error occurs, the attached information that is displayed may not be correct.					

* Error code 16#5730 occurs for unit version 1.06 or later of the CPU Unit.

Event name	Same Track Number Setting in Switch Structure Out of Range		Event code	54015731 hex*		
Meaning	The same track number was specified more than the allowable number of times for the <i>TrackNumber</i> in the <i>Switches</i> in-out variable to a motion control instruction.					
Source	PLC Function Module		Source details	Instruction	Detection timing	At instruction execution
Error attributes	Level	Observation	Recovery	---	Log category	System
Effects	User program	Continues.	Operation	The relevant instruction will end according to specifications.		
System-defined variables	Variable		Data type		Name	
	_MC_AX[*].Obsr.Active		BOOL		Axis Observation Occurrence	
Cause and correction	Assumed cause		Correction		Prevention	
	The same track number was specified more than the allowable number of times for the <i>TrackNumber</i> in the <i>Switches</i> in-out variable to a motion control instruction.		Correct the values in the <i>TrackNumber</i> so that the same track number is not specified more than the maximum number of times.		Set the values in the <i>TrackNumber</i> so that the same track number is not specified more than the maximum number of times.	
Attached information	<p>Attached Information 1: Error Location</p> <p>Attached Information 2: Error Location Details (Rung Number). For a program section, the rung number from the start of the section is given. For ST, the line number is given.</p> <p>Attached Information 3: Name of the Instruction and Instruction Instance Where the Error Occurred. If there is more than one possible instruction, information is given on all of them. Nothing is given if the instruction cannot be identified.</p> <p>Attached Information 4: Expansion Error Code (<i>ErrorIDEx</i>)</p>					
Precautions/Remarks	If a program is changed after an error occurs, the attached information that is displayed may not be correct.					

* Error code 16#5731 occurs for unit version 1.06 or later of the CPU Unit.

Event name	Cannot Write Axis Parameters		Event code	5401573A hex*		
Meaning	The instruction was executed for an axis that is not an unused axis.					
Source	PLC Function Module		Source details	Instruction	Detection timing	At instruction execution
Error attributes	Level	Observation	Recovery	---	Log category	System
Effects	User program	Continues.	Operation	The relevant instruction will end according to specifications.		
System-defined variables	Variable		Data type		Name	
	_MC_COM.MFaultLvl.Active		BOOL		MC Common Minor Fault Occurrence	
Cause and correction	Assumed cause		Correction		Prevention	
	The instruction was executed for a used axis or an undefined axis.		Correct the program so that the MC_ChangeAxisUse (Change Axis Use) instruction is executed after the specified axis is changed to an unused axis.		Write the program so that the specified axis is an unused axis when the instruction is executed.	
Attached information	<p>Attached Information 1: Error Location</p> <p>Attached Information 2: Error Location Details (Rung Number).</p> <p>For a program section, the rung number from the start of the section is given. For ST, the line number is given.</p> <p>Attached Information 3: Names of the Instruction and Instruction Instance Where the Error Occurred. If there is more than one possible instruction, information is given on all of them. Nothing is given if the instruction cannot be identified.</p> <p>Attached Information 4: Expansion Error Code (<i>ErrorIDEx</i>)</p>					
Precautions/Remarks	If a program is changed after an error occurs, the attached information that is displayed may not be correct.					

* Error code 16#573A occurs for unit version 1.08 or later of the CPU Unit.

Event name	Axis Parameter Setting Out of Range			Event code	5401573B hex*	
Meaning	The parameter specified for the <i>AxisParameter</i> input variable to a motion control instruction is outside of the valid range.					
Source	PLC Function Module		Source details	Instruction	Detection timing	At instruction execution
Error attributes	Level	Observation	Recovery	---	Log category	System
Effects	User program	Continues.	Operation	The relevant instruction will end according to specifications.		
System-defined variables	Variable		Data type		Name	
	_MC_COM.MFaultLvl.Active		BOOL		MC Common Minor Fault Occurrence	
Cause and correction	Assumed cause		Correction		Prevention	
	The parameter specified for the <i>Axis-Parameter</i> input variable to the instruction is out of range for the input variable.		Correct the parameter so that the valid range of the input variable is not exceeded for the instruction. Confirm which parameter exceeded the range or what parameters are inconsistent in the attached information.		Set the input parameter to the instruction so that the valid range of the input variable is not exceeded. Refer to information on the <i>MC_WriteAxisParameter</i> (Write Axis Parameters) instruction for the valid ranges of the input variables.	
Attached information	Attached Information 1: Error Location Attached Information 2: Error Location Details (Rung Number). For a program section, the rung number from the start of the section is given. For ST, the line number is given. Attached Information 3: Names of the Instruction and Instruction Instance Where the Error Occurred. If there is more than one possible instruction, information is given on all of them. Nothing is given if the instruction cannot be identified. Attached Information 4: Expansion Error Code (<i>ErrorIDEx</i>)					
Precautions/Remarks	If a program is changed after an error occurs, the attached information that is displayed may not be correct.					

* Error code 16#573B occurs for unit version 1.08 or later of the CPU Unit.

Event name	Cam Property Setting Out of Range			Event code	5401573C hex*	
Meaning	The parameter specified for the <i>CamProperty</i> input variable to a motion control instruction is outside of the valid range.					
Source	PLC Function Module		Source details	Instruction	Detection timing	At instruction execution
Error attributes	Level	Observation	Recovery	---	Log category	System
Effects	User program	Continues.	Operation	The relevant instruction will end according to specifications.		
System-defined variables	Variable		Data type		Name	
	_MC_COM.MFaultLvl.Active		BOOL		MC Common Minor Fault Occurrence	
Cause and correction	Assumed cause		Correction		Prevention	
	The parameter specified for the <i>Cam-Property</i> input variable to the instruction is out of range for the input variable.		Correct the parameter so that the valid range of the input variable is not exceeded for the instruction. Confirm which parameter exceeded the range in the attached information.		Set the input parameter to the instruction so that the valid range of the input variable is not exceeded.	
Attached information	Attached Information 1: Error Location Attached Information 2: Error Location Details (Rung Number). For a program section, the rung number from the start of the section is given. For ST, the line number is given. Attached Information 3: Names of the Instruction and Instruction Instance Where the Error Occurred. If there is more than one possible instruction, information is given on all of them. Nothing is given if the instruction cannot be identified. Attached Information 4: Expansion Error Code (<i>ErrorIDEx</i>)					
Precautions/Remarks	If a program is changed after an error occurs, the attached information that is displayed may not be correct.					

* Error code 16#573C occurs for unit version 1.08 or later of the CPU Unit.

Event name	Cam Node Setting Out of Range			Event code	5401573D hex*
Meaning	The parameter specified for the <i>CamNodes</i> input variable to a motion control instruction is outside of the valid range.				
Source	PLC Function Module		Source details	Instruction	Detection timing At instruction execution
Error attributes	Level	Observation	Recovery	---	Log category System
Effects	User program	Continues.	Operation	The relevant instruction will end according to specifications.	
System-defined variables	Variable		Data type		Name
	_MC_COM.MFaultLvl.Active		BOOL		MC Common Minor Fault Occurrence
Cause and correction	Assumed cause		Correction		Prevention
	The parameter specified for the <i>CamNodes</i> input variable to the instruction is out of range for the input variable.		Correct the parameter so that the valid range of the input variable is not exceeded for the instruction. Confirm which parameter exceeded the range in the attached information.		Set the input parameter to the instruction so that the valid range of the input variable is not exceeded.
Attached information	<p>Attached Information 1: Error Location</p> <p>Attached Information 2: Error Location Details (Rung Number).</p> <p>For a program section, the rung number from the start of the section is given. For ST, the line number is given.</p> <p>Attached Information 3: Names of the Instruction and Instruction Instance Where the Error Occurred. If there is more than one possible instruction, information is given on all of them. Nothing is given if the instruction cannot be identified.</p> <p>Attached Information 4: Expansion Error Code (<i>ErrorIDEx</i>)</p>				
Precautions/Remarks	If a program is changed after an error occurs, the attached information that is displayed may not be correct.				

* Error code 16#573D occurs for unit version 1.08 or later of the CPU Unit.

Event name	Incorrect Cam Node Type Specification			Event code	5401573E hex*
Meaning	The parameter specified for the <i>CamNodes</i> input variable to a motion control instruction is not an <i>_sMC_CAM_NODE</i> array variable.				
Source	PLC Function Module		Source details	Instruction	Detection timing At instruction execution
Error attributes	Level	Observation	Recovery	---	Log category System
Effects	User program	Continues.	Operation	The relevant instruction will end according to specifications.	
System-defined variables	Variable		Data type		Name
	_MC_COM.MFaultLvl.Active		BOOL		MC Common Minor Fault Occurrence
Cause and correction	Assumed cause		Correction		Prevention
	The parameter specified for the <i>CamNodes</i> input variable to the instruction is not an <i>_sMC_CAM_NODE</i> array variable.		Correct the program to specify an <i>sMC_CAM_NODE</i> array variable for the input variable to the instruction.		Write the program to specify an <i>sMC_CAM_NODE</i> array variable for the input variable to the instruction.
Attached information	<p>Attached Information 1: Error Location</p> <p>Attached Information 2: Error Location Details (Rung Number).</p> <p>For a program section, the rung number from the start of the section is given. For ST, the line number is given.</p> <p>Attached Information 3: Names of the Instruction and Instruction Instance Where the Error Occurred. If there is more than one possible instruction, information is given on all of them. Nothing is given if the instruction cannot be identified.</p> <p>Attached Information 4: Expansion Error Code (<i>ErrorIDEx</i>)</p>				
Precautions/Remarks	If a program is changed after an error occurs, the attached information that is displayed may not be correct.				

* Error code 16#573E occurs for unit version 1.08 or later of the CPU Unit.

Event name	Insufficient Nodes in Cam Table			Event code	5401573F hex*	
Meaning	The array variable of the parameter specified for the <i>CamNodes</i> input variable to a motion control instruction has a <i>Phase</i> value of 0 for element number 0.					
Source	PLC Function Module		Source details	Instruction	Detection timing	At instruction execution
Error attributes	Level	Observation	Recovery	---	Log category	System
Effects	User program	Continues.	Operation	The relevant instruction will end according to specifications.		
System-defined variables	Variable		Data type		Name	
	_MC_COM.MFaultLvl.Active		BOOL		MC Common Minor Fault Occurrence	
Cause and correction	Assumed cause		Correction		Prevention	
	The array variable of the parameter specified for the <i>CamNodes</i> input variable to the instruction has a <i>Phase</i> (master axis phase) value of 0 for element number 0.		Correct the program so that the value of <i>Phase</i> (master axis phase) for element number 0 in the array variable for the parameter specified for the <i>CamNodes</i> input variable is not 0.		Write the program so that the value of <i>Phase</i> (master axis phase) for element number 0 in the array variable for the parameter specified for the <i>CamNodes</i> input variable is not 0.	
Attached information	<p>Attached Information 1: Error Location</p> <p>Attached Information 2: Error Location Details (Rung Number).</p> <p>For a program section, the rung number from the start of the section is given. For ST, the line number is given.</p> <p>Attached Information 3: Names of the Instruction and Instruction Instance Where the Error Occurred. If there is more than one possible instruction, information is given on all of them. Nothing is given if the instruction cannot be identified.</p> <p>Attached Information 4: Expansion Error Code (<i>ErrorIDEx</i>)</p>					
Precautions/Remarks	If a program is changed after an error occurs, the attached information that is displayed may not be correct.					

* Error code 16#573F occurs for unit version 1.08 or later of the CPU Unit.

Event name	Cam Node Master Axis Phase Not in Ascending Order			Event code	54015740 hex*	
Meaning	The values of <i>Phase</i> in the array variable of the parameter specified for the <i>CamNodes</i> input variable to a motion control instruction are not in ascending order according to the element numbers.					
Source	PLC Function Module		Source details	Instruction	Detection timing	At instruction execution
Error attributes	Level	Observation	Recovery	---	Log category	System
Effects	User program	Continues.	Operation	The relevant instruction will end according to specifications.		
System-defined variables	Variable		Data type		Name	
	_MC_COM.MFaultLvl.Active		BOOL		MC Common Minor Fault Occurrence	
Cause and correction	Assumed cause		Correction		Prevention	
	The values of <i>Phase</i> (master axis phase) in the array variable of the parameter specified for the <i>CamNodes</i> input variable to the instruction are not in ascending order according to the element numbers. Or, truncating the digits that are not effective more than seven digits caused the phases to not be in ascending order.		Correct the program so that the values of <i>Phase</i> (master axis phase) in the array variable for the parameter specified for the <i>CamNodes</i> input variable are in ascending order according to the element numbers.		Write the program so that the values of <i>Phase</i> (master axis phase) in the array variable for the parameter specified for the <i>CamNodes</i> input variable are in ascending order according to the element numbers.	
Attached information	<p>Attached Information 1: Error Location</p> <p>Attached Information 2: Error Location Details (Rung Number).</p> <p>For a program section, the rung number from the start of the section is given. For ST, the line number is given.</p> <p>Attached Information 3: Names of the Instruction and Instruction Instance Where the Error Occurred. If there is more than one possible instruction, information is given on all of them. Nothing is given if the instruction cannot be identified.</p> <p>Attached Information 4: Expansion Error Code (<i>ErrorIDEx</i>)</p>					
Precautions/Remarks	If a program is changed after an error occurs, the attached information that is displayed may not be correct.					

* Error code 16#5740 occurs for unit version 1.08 or later of the CPU Unit.

Event name	Too Many Data Points in Cam Table		Event code	54015741 hex*		
Meaning	The number of generated cam data points exceeded the number of elements in the array in the cam data variable that is specified for the <i>CamTable</i> input variable to a motion control instruction.					
Source	PLC Function Module		Source details	Instruction	Detection timing	At instruction execution
Error attributes	Level	Observation	Recovery	---	Log category	System
Effects	User program	Continues.	Operation	The relevant instruction will end according to specifications.		
System-defined variables	Variable		Data type		Name	
	_MC_COM.MFaultLvl.Active		BOOL		MC Common Minor Fault Occurrence	
Cause and correction	Assumed cause		Correction		Prevention	
	The number of cam data points in the generated cam table exceeded the number of elements in the array in the cam data variable that is specified for the <i>CamTable</i> input variable to the instruction.		Correct the program so that the number of cam data points in the generated cam table does not exceed the number of elements in the array in the cam data variable that is specified for the <i>CamTable</i> input variable to the instruction. Refer to information on the MC_GenerateCamTable (Generate Cam Table) instruction for the number of cam data points in generated cam tables.		Write the program so that the number of cam data points in the generated cam table does not exceed the number of elements in the array in the cam data variable that is specified for the <i>CamTable</i> input variable to the instruction. Refer to information on the MC_GenerateCamTable (Generate Cam Table) instruction for the number of cam data points in generated cam tables.	
Attached information	Attached Information 1: Error Location Attached Information 2: Error Location Details (Rung Number). For a program section, the rung number from the start of the section is given. For ST, the line number is given. Attached Information 3: Names of the Instruction and Instruction Instance Where the Error Occurred. If there is more than one possible instruction, information is given on all of them. Nothing is given if the instruction cannot be identified. Attached Information 4: Expansion Error Code (<i>ErrorIDEx</i>)					
Precautions/Remarks	If a program is changed after an error occurs, the attached information that is displayed may not be correct.					

* Error code 16#5741 occurs for unit version 1.08 or later of the CPU Unit.

Event name	Cam Table Displacement Overflow		Event code	54015742 hex*		
Meaning	<i>Distance</i> in the generated cam table exceeded the range of REAL data.					
Source	PLC Function Module		Source details	Instruction	Detection timing	At instruction execution or during instruction execution
Error attributes	Level	Observation	Recovery	---	Log category	System
Effects	User program	Continues.	Operation	The relevant instruction will end according to specifications.		
System-defined variables	Variable		Data type		Name	
	_MC_COM.MFaultLvl.Active		BOOL		MC Common Minor Fault Occurrence	
Cause and correction	Assumed cause		Correction		Prevention	
	<i>Distance</i> in the generated cam table exceeded the range of REAL data.		Correct the values of <i>InitVel</i> (initial velocity), <i>ConnectingVel</i> (connecting velocity), and <i>ConnectingAcc</i> (connecting acceleration) so that <i>Distance</i> does not overflow when a polynomial 3 curve or polynomial 5 curve is specified for <i>Curve</i> (curve shape) in the <i>CamNodes</i> input variable. Refer to information on the MC_GenerateCamTable (Generate Cam Table) instruction for the method to calculate <i>Distance</i> .		Specify the values of <i>InitVel</i> (initial velocity), <i>ConnectingVel</i> (connecting velocity), and <i>ConnectingAcc</i> (connecting acceleration) so that <i>Distance</i> does not overflow when a polynomial 3 curve or polynomial 5 curve is specified for <i>Curve</i> (curve shape) in the <i>CamNodes</i> input variable. Refer to information on the MC_GenerateCamTable (Generate Cam Table) instruction for the method to calculate <i>Distance</i> .	
Attached information	Attached Information 1: Error Location Attached Information 2: Error Location Details (Rung Number). For a program section, the rung number from the start of the section is given. For ST, the line number is given. Attached Information 3: Names of the Instruction and Instruction Instance Where the Error Occurred. If there is more than one possible instruction, information is given on all of them. Nothing is given if the instruction cannot be identified. Attached Information 4: Expansion Error Code (<i>ErrorIDEx</i>)					
Precautions/Remarks	If a program is changed after an error occurs, the attached information that is displayed may not be correct.					

* Error code 16#5742 occurs for unit version 1.08 or later of the CPU Unit.

Event name	Aborted Cam Table Used		Event code	54015743 hex*	
Meaning	A cam data variable that was aborted during generation was specified for the <i>CamTable</i> input variable to an instruction.				
Source	PLC Function Module	Source details	Instruction	Detection timing	At instruction execution
Error attributes	Level	Observation	Recovery	---	Log category System
Effects	User program	Continues.	Operation	The relevant instruction will end according to specifications.	
System-defined variables	Variable		Data type		Name
	_MC_COM.MFaultLvl.Active		BOOL		MC Common Minor Fault Occurrence
	_MC_AX[*].MFaultLvl.Active		BOOL		Axis Minor Fault Occurrence
Cause and correction	Assumed cause		Correction		Prevention
	A cam data variable that was aborted during generation due to an error in the MC_GenerateCamTable (Generate Cam Table) instruction was specified for the <i>CamTable</i> input variable to the instruction.		Check the <i>ErrorID</i> (error code), <i>ErrorParameterCode</i> (parameter detail code), and <i>ErrorNodePointIndex</i> (node point element number) output variables from the MC_GenerateCamTable (Generate Cam Table) instruction and correct the program so that correct cam data variables are created.		Write the program so that the MC_GenerateCamTable (Generate Cam Table) instruction creates correct cam data variables. Or, write the program so that the relevant instruction is executed only when the MC_GenerateCamTable (Generate Cam Table) instruction ends normally.
Attached information	<p>Attached Information 1: Error Location</p> <p>Attached Information 2: Error Location Details (Rung Number).</p> <p>For a program section, the rung number from the start of the section is given. For ST, the line number is given.</p> <p>Attached Information 3: Names of the Instruction and Instruction Instance Where the Error Occurred. If there is more than one possible instruction, information is given on all of them. Nothing is given if the instruction cannot be identified.</p> <p>Attached Information 4: Expansion Error Code (<i>ErrorIDEx</i>)</p>				
Precautions/Remarks	If a program is changed after an error occurs, the attached information that is displayed may not be correct.				

* Error code 16#5743 occurs for unit version 1.08 or later of the CPU Unit.

Event name	Execution ID Setting Out of Range			Event code	54015749 hex*	
Meaning	The parameter specified for the <i>ExecID</i> input variable to a motion control instruction is out of range.					
Source	PLC Function Module		Source details	Instruction	Detection timing	At instruction execution
Error attributes	Level	Observation	Recovery	---	Log category	System
Effects	User program	Continues.	Operation	The relevant instruction will end according to specifications.		
System-defined variables	Variable		Data type		Name	
	_MC_AX[*].MFAultLvl.Active		BOOL		Axis Minor Fault Occurrence	
Cause and correction	Assumed cause		Correction		Prevention	
	The parameter specified for the <i>ExecID</i> input variable to the instruction is out of range for the input variable.		Correct the program so that the input parameter specified for the <i>ExecID</i> input variable to the instruction is within the setting range.		Create the program so that the input parameter specified for the <i>ExecID</i> input variable to the instruction is within the setting range.	
Attached information	<p>Attached Information 1: Error Location</p> <p>Attached Information 2: Error Location Details (Rung Number). For a program section, the rung number from the start of the section is given. For ST, the line number is given.</p> <p>Attached Information 3: Names of the Instruction and Instruction Instance Where the Error Occurred. If there is more than one possible instruction, information is given on all of them. Nothing is given If the instruction cannot be identified.</p> <p>Attached Information 4: Expansion Error Code (<i>ErrorIDEx</i>)</p>					
Precautions/Remarks	If a program is changed after an error occurs, the attached information that is displayed may not be correct.					

* Error code 16#5749 occurs for unit version 1.10 or later of the CPU Unit.

Event name	Position Offset Out of Range			Event code	5401574A hex*	
Meaning	The parameter specified for the <i>OffsetPosition</i> input variable to a motion control instruction is out of range.					
Source	PLC Function Module		Source details	Instruction	Detection timing	At instruction execution
Error attributes	Level	Observation	Recovery	---	Log category	System
Effects	User program	Continues.	Operation	The relevant instruction will end according to specifications.		
System-defined variables	Variable		Data type		Name	
	_MC_AX[*].MFAultLvl.Active		BOOL		Axis Minor Fault Occurrence	
Cause and correction	Assumed cause		Correction		Prevention	
	The instruction input parameter exceeded the range of signed 40-bit data when it was converted to pulses.		Correct the parameter so that the valid range of the input variable is not exceeded for the relevant instruction.		Set the input parameter to the instruction so that the valid range of the input variable is not exceeded.	
Attached information	<p>Attached Information 1: Error Location</p> <p>Attached Information 2: Error Location Details (Rung Number). For a program section, the rung number from the start of the section is given. For ST, the line number is given.</p> <p>Attached Information 3: Names of the Instruction and Instruction Instance Where the Error Occurred. If there is more than one possible instruction, information is given on all of them. Nothing is given If the instruction cannot be identified.</p> <p>Attached Information 4: Expansion Error Code (<i>ErrorIDEx</i>)</p>					
Precautions/Remarks	If a program is changed after an error occurs, the attached information that is displayed may not be correct.					

* Error code 16#574A occurs for unit version 1.10 or later of the CPU Unit.

Event name	PDS State Transition Command Selection Out of Range		Event code	5401574B hex*		
Meaning	The parameter specified for the <i>TransitionCmd</i> input variable to a motion control instruction is out of range.					
Source	PLC Function Module		Source details	Instruction	Detection timing	At instruction execution
Error attributes	Level	Observation	Recovery	---	Log category	System
Effects	User program	Continues.	Operation	The relevant instruction will end according to specifications.		
System-defined variables	Variable		Data type		Name	
	_MC_AX[*].MFAultLvl.Active		BOOL		Axis Minor Fault Occurrence	
Cause and correction	Assumed cause		Correction		Prevention	
	Instruction input parameter exceeded the valid range of the input variable.		Correct the parameter so that the valid range of the input variable is not exceeded for the relevant instruction.		Set the input parameter to the instruction so that the valid range of the input variable is not exceeded.	
Attached information	<p>Attached Information 1: Error Location</p> <p>Attached Information 2: Error Location Details (Rung Number). For a program section, the rung number from the start of the section is given. For ST, the line number is given.</p> <p>Attached Information 3: Names of the Instruction and Instruction Instance Where the Error Occurred. If there is more than one possible instruction, information is given on all of them. Nothing is given if the instruction cannot be identified.</p> <p>Attached Information 4: Expansion Error Code (<i>ErrorIDEx</i>)</p>					
Precautions/Remarks	If a program is changed after an error occurs, the attached information that is displayed may not be correct.					

* Error code 16#574B occurs for unit version 1.10 or later of the CPU Unit.

Event name	Single-axis Position Control Axis Motion Control Instruction Execution Disabled		Event code	5401574C hex *1		
Meaning	An operation instruction was executed for a single-axis position control axis.					
Source	PLC Function Module		Source details	Instruction	Detection timing	At instruction execution
Error attributes	Level	Observation	Recovery	---	Log category	System
Effects	User program	Continues.	Operation	The relevant instruction will end according to specifications.		
System-defined variables	Variable		Data type		Name	
	_MC_AX[*].MFAultLvl.Active		BOOL		Axis Minor Fault Occurrence	
Cause and correction	Assumed cause		Correction		Prevention	
	An operation instruction was executed for a single-axis position control axis.		In the Axis Basic Settings for the axis specified in the instruction, set the Control Function parameter to 0: All. Or specify the axis for which the Control Function parameter is set to 0: All in the Axis Basic Settings.		Same as at the left.	
Attached information	<p>Attached Information 1: Error Location</p> <p>Attached Information 2: Error Location Details (Rung Number). For a program section, the rung number from the start of the section is given. For ST, the line number is given.</p> <p>Attached Information 3: Names of the Instruction and Instruction Instance Where the Error Occurred. If there is more than one possible instruction, information is given on all of them. Nothing is given if the instruction cannot be identified.</p> <p>Attached Information 4: Expansion Error Code (<i>ErrorIDEx</i>)</p>					
Precautions/Remarks	If a program is changed after an error occurs, the attached information that is displayed may not be correct.					

*1 Error code 16#574C occurs for unit version 1.13 or later of the CPU Unit.

Event name	Target Position Positive Software Limit Exceeded		Event code	54016440 hex		
Meaning	The specified position exceeds the positive software limit.					
Source	PLC Function Module		Source details	Instruction	Detection timing	At instruction execution
Error attributes	Level	Observation	Recovery	---	Log category	System
Effects	User program	Continues.	Operation	The relevant instruction will end according to specifications.		
System-defined variables	Variable		Data type		Name	
	_MC_AX[*].MFaultLvl.Active		BOOL		Axis Minor Fault Occurrence	
	_MC_GRP[*].MFaultLvl.Active		BOOL		Axes Group Minor Fault Occurrence	
Cause and correction	Assumed cause		Correction		Prevention	
	The parameter specified for the <i>Position</i> input variable to the instruction is beyond the positive software limit.		Correct the parameter specified for the <i>Position</i> input variable to the instruction so that it is within the positive software limit.		Set the parameter specified for the <i>Position</i> input variable to the instruction so that it is within the positive software limit.	
	The starting position is beyond the positive software limit and an instruction that specifies motion in the opposite direction of the software limit was executed.		Correct the program so that the travel direction for the instruction is towards the positive software limit.		If the starting position is beyond the positive software limit, write the program so that the travel direction is in the direction of the positive software limit.	
	The parameter that was specified for the <i>AuxPoint</i> input variable to a border point MC_MoveCircular2D (Circular 2D Interpolation) instruction is beyond the positive software limit.		Correct the parameter specified for the <i>AuxPoint</i> input variable to the instruction so that it is within the positive software limit.		Set the parameter specified for the <i>AuxPoint</i> input variable to the border point MC_MoveCircular2D (Circular 2D Interpolation) instruction so that it is within the positive software limit.	
Attached information	<p>Attached Information 1: Error Location</p> <p>Attached Information 2: Error Location Details (Rung Number). For a program section, the rung number from the start of the section is given. For ST, the line number is given.</p> <p>Attached Information 3: Names of the Instruction and Instruction Instance Where the Error Occurred. If there is more than one possible instruction, information is given on all of them. Nothing is given if the instruction cannot be identified.</p> <p>Attached Information 4: Expansion Error Code (<i>ErrorIDEx</i>)</p>					
Precautions/Remarks	If a program is changed after an error occurs, the attached information that is displayed may not be correct.					

Event name	Target Position Negative Software Limit Exceeded		Event code	54016441 hex		
Meaning	The specified position exceeds the negative software limit.					
Source	PLC Function Module		Source details	Instruction	Detection timing	At instruction execution
Error attributes	Level	Observation	Recovery	---	Log category	System
Effects	User program	Continues.	Operation	The relevant instruction will end according to specifications.		
System-defined variables	Variable		Data type		Name	
	_MC_AX[*].MFaultLvl.Active		BOOL		Axis Minor Fault Occurrence	
	_MC_GRP[*].MFaultLvl.Active		BOOL		Axes Group Minor Fault Occurrence	
Cause and correction	Assumed cause		Correction		Prevention	
	The parameter specified for the <i>Position</i> input variable to the instruction is beyond the negative software limit.		Correct the parameter specified for the <i>Position</i> input variable to the instruction so that it is within the negative software limit.		Correct the input parameter specified for the <i>Position</i> input variable to the instruction so that it is within the negative software limit.	
	The starting position is beyond the negative software limit and an instruction that specifies motion in the opposite direction of the software limit was executed.		Correct the program so that the travel direction for the instruction is towards the negative software limit.		If the starting position is beyond the negative software limit, write the program so that the travel direction is in the direction of the negative software limit.	
	The parameter that was specified for the <i>AuxPoint</i> input variable to a border point MC_MoveCircular2D (Circular 2D Interpolation) instruction is beyond the negative software limit.		Correct the parameter specified for the <i>AuxPoint</i> input variable to the instruction so that it is within the negative software limit.		Set the parameter specified for the <i>AuxPoint</i> input variable to the border point MC_MoveCircular2D (Circular 2D Interpolation) instruction so that it is within the negative software limit.	
Attached information	<p>Attached Information 1: Error Location</p> <p>Attached Information 2: Error Location Details (Rung Number). For a program section, the rung number from the start of the section is given. For ST, the line number is given.</p> <p>Attached Information 3: Names of the Instruction and Instruction Instance Where the Error Occurred. If there is more than one possible instruction, information is given on all of them. Nothing is given if the instruction cannot be identified.</p> <p>Attached Information 4: Expansion Error Code (<i>ErrorIDEx</i>)</p>					
Precautions/Remarks	If a program is changed after an error occurs, the attached information that is displayed may not be correct.					

Event name	Command Position Overflow/Underflow		Event code	5401 6442 hex		
Meaning	Positioning, an instruction in the underflow/overflow direction, or an instruction for which the direction is not specified was executed when there was an underflow/overflow in the command position.					
Source	PLC Function Module		Source details	Instruction	Detection timing	At instruction execution
Error attributes	Level	Observation	Recovery	---	Log category	System
Effects	User program	Continues.	Operation	The relevant instruction will end according to specifications.		
System-defined variables	Variable		Data type		Name	
	_MC_AX[*].MFaultLvl.Active		BOOL		Axis Minor Fault Occurrence	
Cause and correction	Assumed cause		Correction		Prevention	
	<p>One of the following was executed when there was a command position overflow/underflow.</p> <ul style="list-style-type: none"> • A positioning instruction • A continuous control instruction in the underflow/overflow direction • An instruction for which the direction is not specified (syncing or torque control) 		<p>Execute an error reset and then clear the overflow/underflow state by executing homing or presetting the actual position.</p>		<p>Make sure that overflow or underflow does not occur.</p>	
Attached information	<p>Attached Information 1: Depends on the source details</p> <p>Axis: 0</p> <p>Axes group: Logical axis number</p>					
Precautions/Remarks	If a program is changed after an error occurs, the attached information that is displayed may not be correct.					

Event name	Positive Limit Input		Event code	54016443 hex		
Meaning	An instruction was executed for a motion in the positive direction when the positive limit input was ON.					
Source	PLC Function Module		Source details	Instruction	Detection timing	At instruction execution
Error attributes	Level	Observation	Recovery	---	Log category	System
Effects	User program	Continues.	Operation	The relevant instruction will end according to specifications.		
System-defined variables	Variable		Data type		Name	
	_MC_AX[*].MFaultLvl.Active		BOOL		Axis Minor Fault Occurrence	
	_MC_GRP[*].MFaultLvl.Active		BOOL		Axes Group Minor Fault Occurrence	
Cause and correction	Assumed cause		Correction		Prevention	
	An instruction for a motion in the positive direction was executed when the positive limit input was ON, or an instruction for a motion with no direction specification was executed when the positive limit input was ON. An axes group motion control instruction was executed when the positive limit input was ON.		Execute an error reset and then perform a recovery operation in the negative direction. If the error occurred during an axes group motion control instruction, disable the axes group and then perform the above operation. If this error occurs again, check the connection of the positive limit signal, the logic setting for the positive limit input, and the execution conditions for the start command, and correct any mistakes. Check the logic settings both in the axis parameters and in the slave settings.		Check to make sure there are no problems with the positive limit signal connection, the logic setting for the positive limit input, and the execute conditions for the instruction. Check the logic settings both in the axis parameters and in the slave settings.	
Attached information	Attached Information 1: Error Location Attached Information 2: Error Location Details (Rung Number). For a program section, the rung number from the start of the section is given. For ST, the line number is given. Attached Information 3: Names of the Instruction and Instruction Instance Where the Error Occurred. If there is more than one possible instruction, information is given on all of them. Nothing is given if the instruction cannot be identified. Attached Information 4: Expansion Error Code (<i>ErrorIDEx</i>)					
Precautions/Remarks	If a program is changed after an error occurs, the attached information that is displayed may not be correct.					

Event name	Negative Limit Input			Event code	54016444 hex	
Meaning	An instruction for a motion in the negative direction was executed when the negative limit input was ON.					
Source	PLC Function Module		Source details	Instruction	Detection timing	At instruction execution
Error attributes	Level	Observation	Recovery	---	Log category	System
Effects	User program	Continues.	Operation	The relevant instruction will end according to specifications.		
System-defined variables	Variable		Data type		Name	
	_MC_AX[*].MFAultLvl.Active		BOOL		Axis Minor Fault Occurrence	
	_MC_GRP[*].MFAultLvl.Active		BOOL		Axes Group Minor Fault Occurrence	
Cause and correction	Assumed cause		Correction		Prevention	
	An instruction for a motion in the negative direction was executed when the negative limit input was ON, or an instruction for a motion with no direction specification was executed when the negative limit input was ON. An axes group motion control instruction was executed when the negative limit input was ON.		Execute an error reset and then perform a recovery operation in the positive direction. If the error occurred during an axes group motion control instruction, disable the axes group and then perform the above operation. If this error occurs again, check the connection of the negative limit signal, the logic setting for the negative limit input, and the execution conditions for the start command, and correct any mistakes. Check the logic settings both in the axis parameters and in the slave settings.		Check to make sure there are no problems with the negative limit signal connection, the logic setting for the negative limit input, and the execute conditions for the instruction. Check the logic settings both in the axis parameters and in the slave settings.	
Attached information	<p>Attached Information 1: Error Location</p> <p>Attached Information 2: Error Location Details (Rung Number). For a program section, the rung number from the start of the section is given. For ST, the line number is given.</p> <p>Attached Information 3: Names of the Instruction and Instruction Instance Where the Error Occurred. If there is more than one possible instruction, information is given on all of them. Nothing is given if the instruction cannot be identified.</p> <p>Attached Information 4: Expansion Error Code (<i>ErrorIDEx</i>)</p>					
Precautions/Remarks	If a program is changed after an error occurs, the attached information that is displayed may not be correct.					

Event name	Servo Main Circuits OFF			Event code	54017422 hex	
Meaning	An attempt was made to turn ON the Servo when the main circuit power supply to the Servo Drive was OFF.					
Source	PLC Function Module		Source details	Instruction	Detection timing	At instruction execution
Error attributes	Level	Observation	Recovery	---	Log category	System
Effects	User program	Continues.	Operation	The relevant instruction will end according to specifications.		
System-defined variables	Variable		Data type		Name	
	_MC_AX[*].MFAultLvl.Active		BOOL		Axis Minor Fault Occurrence	
Cause and correction	Assumed cause		Correction		Prevention	
	An attempt was made to turn ON the Servo when the main circuit power supply to the Servo Drive was OFF.		Turn ON the Servo after turning ON the main circuit power of the Servo Drive for the axis where the error occurred.		Turn ON the Servo after turning ON the main circuit power supply to the Servo Drive.	
Attached information	<p>Attached Information 1: Error Location</p> <p>Attached Information 2: Error Location Details (Rung Number). For a program section, the rung number from the start of the section is given. For ST, the line number is given.</p> <p>Attached Information 3: Names of the Instruction and Instruction Instance Where the Error Occurred. If there is more than one possible instruction, information is given on all of them. Nothing is given if the instruction cannot be identified.</p> <p>Attached Information 4: Expansion Error Code (<i>ErrorIDEx</i>)</p>					
Precautions/Remarks	If a program is changed after an error occurs, the attached information that is displayed may not be correct.					

A-4 Instructions You Cannot Use in Event Tasks

An event task is executed only once when the specified execution condition is met. They are not executed repeatedly each task period. Therefore, programs that contain instructions that are executed over more than one task period cannot be assigned to event tasks.

The instructions in the following table are executed over more than one task. Do not use these instructions in programs that are assigned to an event task. If you do, a building error will occur.

Type	Instruction	Name	Page
Stack and Table Instructions	RecSort	Record Sort	2-518
Analog Control Instructions	PIDAT	PID Control with Autotuning	2-666
	PIDAT_HeatCool	Heating/Cooling PID with Autotuning	2-691
	AC_StepProgram	Step Program	2-772
System Control Instructions	ResetPLCError	Reset PLC Controller Error	2-817
	ResetCJError	Reset I/O Bus Error	2-822
	ResetMCErr	Reset Motion Control Error	2-828
	ResetECErr	Reset EtherCAT Error	2-835
	ResetNXBErr	Reset NX Bus Error	2-840
	GetNXUnitErr	Get NX Unit Error Status	2-844
	ResetUnit	Restart Unit	2-854
	RestartNXUnit	Restart NX Unit	2-860
	NX_ChangeWriteMode	Change to NX Unit Write Mode	2-866
	NX_SaveParam	Save NX Unit Parameters	2-871
	NX_ReadTotalPowerOnTime	Read NX Unit Total Power ON Time	2-877
EtherCAT Communications Instructions	EC_CoESDOWrite	Write EtherCAT CoE SDO	2-926
	EC_CoESDORead	Read EtherCAT CoE SDO	2-929
	EC_StartMon	Start EtherCAT Packet Monitor	2-934
	EC_StopMon	Stop EtherCAT Packet Monitor	2-940
	EC_SaveMon	Save EtherCAT Packets	2-942
	EC_CopyMon	Transfer EtherCAT Packets	2-944
	EC_DisconnectSlave	Disconnect EtherCAT Slave	2-946
	EC_ConnectSlave	Connect EtherCAT Slave	2-953
	EC_ChangeEnableSetting	Enable/Disable EtherCAT Slave	2-955
	NX_WriteObj	Write NX Unit Object	2-972
	NX_ReadObj	Read NX Unit Object	2-987
IO-Link Communications Instructions	IOL_ReadObj	Read IO-Link Device Object	2-998
	IOL_WriteObj	Write IO-Link Device Object	2-1007
EtherNet/IP Communications Instructions	CIPOpen	Open CIP Class 3 Connection (Large_Forward_Open)	2-1018
	CIPOpenWithDataSize	Open CIP Class 3 Connection with Specified Data Size	2-1027
	CIPRead	Read Variable Class 3 Explicit	2-1031
	CIPWrite	Write Variable Class 3 Explicit	2-1037
	CIPSend	Send Explicit Message Class 3	2-1043
	CIPCclose	Close CIP Class 3 Connection	2-1048
	CIPUCMMRead	Read Variable UCMM Explicit	2-1051
	CIPUCMMWrite	Write Variable UCMM Explicit	2-1056
	CIPUCMMSend	Send Explicit Message UCMM	2-1063

Type	Instruction	Name	Page
EtherNet/IP Communications Instructions	SkUDPCreate	Create UDP Socket	2-1073
	SkUDPRcv	UDP Socket Receive	2-1081
	SkUDPSend	UDP Socket Send	2-1084
	SkTCPAccept	Accept TCP Socket	2-1087
	SkTCPConnect	Connect TCP Socket	2-1090
	SkTCPRcv	TCP Socket Receive	2-1099
	SkTCPSend	TCP Socket Send	2-1102
	SkGetTCPStatus	Read TCP Socket Status	2-1105
	SkClose	Close TCP/UDP Socket	2-1108
	SkClearBuf	Clear TCP/UDP Socket Receive Buffer	2-1111
	SkSetOption	Set TCP Socket Option	2-1114
	ChangeIPAdr	Change IP Address	2-1119
	ChangeFTPAccount	Change FTP Account	2-1127
	ChangeNTPServerAdr	Change NTP Server Address	2-1131
	FTPGetFileList	Get FTP Server File List	2-1135
	FTPGetFile	Get File from FTP Server	2-1152
	FTPPutFile	Put File onto FTP Server	2-1161
	FTPRemoveFile	Delete FTP Server File	2-1172
	FTPRemoveDir	Delete FTP Server Directory	2-1182
	Serial Communications Instructions	ExecPMCR	Protocol Macro
SerialSend		SCU Send Serial	2-1201
SerialRcv		SCU Receive Serial	2-1212
SerialRcvNoClear		SCU Receive Serial without Receive Buffer Clear	2-1212
SendCmd		Send Command	2-1227
NX_SerialSend		Send No-protocol Data	2-1240
NX_SerialRcv		Receive No-protocol Data	2-1253
NX_ModbusRtuCmd		Send Modbus RTU General Command	2-1267
NX_ModbusRtuRead		Send Modbus RTU Read Command	2-1277
NX_ModbusRtuWrite		Send Modbus RTU Write Command	2-1288
NX_SerialSigCtl		Serial Control Signal ON/OFF Switching	2-1299
NX_SerialSigRead		Read Serial Control Signal	2-1308
NX_SerialStatusRead		Read Serial Port Status	2-1313
NX_SerialBufClear		Clear Buffer	2-1318
NX_SerialStartMon		Start Serial Line Monitoring	2-1328
NX_SerialStopMon		Stop Serial Line Monitoring	2-1333
SD Memory Card Instructions		FileWriteVar	Write Variable to File
	FileReadVar	Read Variable from File	2-1343
	FileOpen	Open File	2-1348
	FileClose	Close File	2-1352
	FileSeek	Seek File	2-1355
	FileRead	Read File	2-1359
	FileWrite	Write File	2-1367
	FileGets	Get Text String	2-1375
	FilePuts	Put Text String	2-1383
	FileCopy	Copy File	2-1392
	FileRemove	Delete File	2-1401
	FileRename	Change File Name	2-1406
	DirCreate	Create Directory	2-1411
	DirRemove	Delete Directory	2-1414
BackupToMemoryCard	SD Memory Card Backup	2-1417	
Time Stamp Instructions	NX_DOutTimeStamp	Write Digital Output with Specified Time Stamp	2-1434
	NX_AryDOutTimeStamp	Write Digital Output Array with Specified Time Stamp	2-1440

A-5 Instructions Related to NX Message Communications Errors

If too many of the following instructions are executed at the same time, an NX Message Communications Error may occur. If an NX Message Communications Error occurs, reduce the number of the following instructions that are executed. The conditions for an NX Message Communications Error depends on factors such as the communications traffic.

Classification	Instruction	Name	Page
System Control Instructions	RestartNXUnit	Restart NX Unit	2-860
	NX_ChangeWriteMode	Change to NX Unit Write Mode	2-866
	NX_SaveParam	Save NX Unit Parameters	2-871
	NX_ReadTotalPowerOn-Time	Read NX Unit Total Power ON Time	2-877
EtherCAT Communications Instructions	EC_CoESDOWrite	Write EtherCAT CoE SDO	2-926
	EC_CoESDORead	Read EtherCAT CoE SDO	2-929
	EC_StartMon	Start EtherCAT Packet Monitor	2-934
	EC_StopMon	Stop EtherCAT Packet Monitor	2-940
	EC_SaveMon	Save EtherCAT Packets	2-942
	EC_CopyMon	Transfer EtherCAT Packets	2-944
	EC_DisconnectSlave	Disconnect EtherCAT Slave	2-946
	EC_ConnectSlave	Connect EtherCAT Slave	2-953
	EC_ChangeEnableSetting	Enable/Disable EtherCAT Slave	2-955
	NX_WriteObj	Write NX Unit Object	2-972
	NX_ReadObj	Read NX Unit Object	2-987
IO-Link Communications Instructions	IOL_ReadObj	Read IO-Link Device Object	2-998
	IOL_WriteObj	Write IO-Link Device Object	2-1007



Version Information

A CPU Unit with unit version 1.05 or later and Sysmac Studio version 1.06 or higher are required for an NX Message Communications Error to occur.

A-6 SDO Abort Codes

As reference information, the following table lists the SDO abort codes for EtherCAT communications. The abort codes that are used in actual communications are specified by the slaves. Refer to the slave manuals when programming communications.

Value	Meaning
16#05030000	Toggle bit not changed
16#05040000	SDO protocol timeout
16#05040001	Client/Server command specifier not valid or unknown
16#05040005	Out of memory
16#06010000	Unsupported access to an object
16#06010001	Attempt to read to a write only object
16#06010002	Attempt to write to a read only object
16#06020000	The object does not exist in the object directory
16#06040041	The object cannot be mapped into the PDO
16#06040042	The number and length of the objects to be mapped would exceed the PDO length
16#06040043	General parameter incompatibility reason
16#06040047	General internal incompatibility in the device
16#06060000	Access failed due to a hardware error
16#06070010	Data type does not match, length of service parameter does not match
16#06070012	Data type does not match, length of service parameter too high
16#06070013	Data type does not match, length of service parameter too low
16#06090011	Subindex does not exist
16#06090030	Value range of parameter exceeded (only for write access)
16#06090031	Value of parameter written too high
16#06090032	Value of parameter written too low
16#06090036	Maximum value is less than minimum value
16#08000000	General error
16#08000020	Data cannot be transferred or stored to the application
16#08000021	Data cannot be transferred or stored to the application because of local control*
16#08000022	Data cannot be transferred or stored to the application because of the present device state
16#08000023	Object dictionary dynamic generation failed or no object dictionary is present

* This is internal status that is unique to the slave.

Source: EtherCAT Specification Part 6 Application Layer Protocol Specification.

Document No.: ETG.1000.6 S (R) V1.0.2

A-7 Version Information

This appendix lists the instructions for which specifications were changed and instructions that were added for different unit versions of the CPU Units and for different versions of the Sysmac Studio.

It also describes the actions to take if the following error message is displayed for Sysmac Studio version 1.02: The instruction may cause unintended operations.

Instructions with Specifications Changes and New Instructions for Version Upgrades

The instructions that are supported and their specifications depend on the unit version of the CPU Unit and the version of the Sysmac Studio. These are given in the following table.

If a version is given for both the CPU Unit and Sysmac Studio, both versions are required.

Type	Instruction	Name	New/Changed	Versions		Page
				CPU Unit	Sysmac Studio	
ST Statement Instructions	FOR	Repeat Start	Changed	---	Ver. 1.08	2-42
Sequence Input Instructions	R_TRIG	Up Trigger	Changed	Ver. 1.02	---	2-44
Sequence Output Instructions	RS	Reset-Priority Keep	Changed	---	Ver. 1.03	2-50
	SR	Set-Priority Keep	Changed	---	Ver. 1.03	2-53
Comparison Instructions	EQ,=	Equal	Changed	---	Ver. 1.02	2-92
	NE,<>	Not Equal	Changed	---	Ver. 1.02	2-94
	LT,<	Less Than	Changed	---	Ver. 1.02	2-97
	LE,<=	Less Than Or Equal	Changed	---	Ver. 1.02	2-97
	GT,>	Greater Than	Changed	---	Ver. 1.02	2-97
	GE,>=	Greater Than Or Equal	Changed	---	Ver. 1.02	2-97
	ZoneCmp	Zone Comparison	Changed	Ver. 1.01	Ver. 1.02	2-109
Counter Instructions	CTD	Down-counter	Changed	---	Ver. 1.03	2-146
	CTD_**	Down-counter Group	Changed	---	Ver. 1.03	2-148
	CTU	Up-counter	Changed	---	Ver. 1.03	2-150
	CTU_**	Up-counter Group	Changed	---	Ver. 1.03	2-152
	CTUD	Up-down Counter	Changed	---	Ver. 1.03	2-155
	CTUD_**	Up-down Counter Group	Changed	---	Ver. 1.03	2-159
Math Instructions	EXPT (**)	Exponentiation	Changed	Ver. 1.16	Ver. 1.20	2-211
Data Type Conversion Instructions	EnumToNum	Enumeration-to-Integer	New	Ver. 1.02	Ver. 1.03	2-312
	NumToEnum	Integer-to-Enumeration	New	Ver. 1.02	Ver. 1.03	2-314
Selection Instructions	SEL	Binary Selection	Changed	Ver. 1.02	Ver. 1.03	2-332
	MUX	Multiplexer	Changed	Ver. 1.02	Ver. 1.03	2-334
	AryMax	Array Maximum	Changed	Ver. 1.01	Ver. 1.02	2-347
	AryMin	Array Minimum	Changed	Ver. 1.01	Ver. 1.02	2-347
	ArySerach	Array Search	Changed	Ver. 1.01	Ver. 1.02	2-350

Type	Instruction	Name	New/Changed	Versions		Page
				CPU Unit	Sysmac Studio	
Shift Instructions	SHL	N-bit Left Shift	Changed	Ver. 1.02	Ver. 1.03	2-396
	SHR	N-bit Right Shift	Changed	Ver. 1.02	Ver. 1.03	2-396
	ROL	Rotate N-bits Left	Changed	Ver. 1.02	Ver. 1.03	2-400
	ROR	Rotate N-bits Right	Changed	Ver. 1.02	Ver. 1.03	2-400
Conversion Instructions	UTF8ToSJIS	UTF-8 to SJIS Character Code Conversion	New	Ver. 1.01	Ver. 1.02	2-422
	SJISToUTF8	SJIS to UTF-8 Character Code Conversion	New	Ver. 1.01	Ver. 1.02	2-424
	PWLApproxNoLineChk	Broken Line Approximation without Broken Line Data Check	New	Ver. 1.03	Ver. 1.04	2-426
	PWLLineChk	Broken Line Data Check	New	Ver. 1.03	Ver. 1.04	2-432
	PackWord	2-byte Join	New	Ver. 1.12	Ver. 1.16	2-487
	PackDword	4-byte Join	New	Ver. 1.12	Ver. 1.16	2-489
Stack and Table Instructions	RecSearch	Record Search	Changed	Ver. 1.01	Ver. 1.02	2-508
	RecRangeSearch	Range Record Search	Changed	Ver. 1.01	Ver. 1.02	2-513
	RecSort	Record Sort	Changed	Ver. 1.01	Ver. 1.02	2-518
	RecNum	Get Number of Records	Changed	Ver. 1.01 Ver. 1.02	Ver. 1.02 Ver. 1.03	2-524
	RecMax	Maximum Record Search	Changed	Ver. 1.01	Ver. 1.02	2-526
	RecMin	Minimum Record Search	Changed	Ver. 1.01	Ver. 1.02	2-526
Text String Instructions	AddDelimiter	Put Text Strings with Delimiters	New	Ver. 1.02	Ver. 1.03	2-571
	SubDelimiter	Get Text Strings Minus Delimiters	New	Ver. 1.02	Ver. 1.03	2-582
Time and Time of Day Instructions	TruncTime	Truncate Time	New	Ver. 1.01	Ver. 1.02	2-652
	TruncDt	Truncate Date and Time	New	Ver. 1.01	Ver. 1.02	2-656
	TruncTod	Truncate Time of Day	New	Ver. 1.01	Ver. 1.02	2-660
Analog Control Instructions	PIDAT_HeatCool	Heating/Cooling PID with Autotuning	New	Ver. 1.08	Ver. 1.09	2-691
	TimeProportionalOut	Time-proportional Output	New	Ver. 1.02	Ver. 1.03	2-729
	LimitAlarm_**	Upper/Lower Limit Alarm Group	New	Ver. 1.02	Ver. 1.03	2-745
	LimitAlarmDv_**	Upper/Lower Deviation Alarm Group	New	Ver. 1.02	Ver. 1.03	2-749
	LimitAlarmDvStbySeq_**	Upper/Lower Deviation Alarm with Standby Sequence Group	New	Ver. 1.02	---	2-754
	ScaleTrans	Scale Transformation	New	Ver. 1.05	Ver. 1.06	2-769

Type	Instruction	Name	New/Changed	Versions		Page
				CPU Unit	Sysmac Studio	
Analog Control Instructions	AC_StepProgram	Step Program	New	Ver. 1.06	Ver. 1.07	2-772
System Control Instructions	ResetMCError	Reset Motion Control Error	Changed	Ver. 1.02	Ver. 1.03	2-828
				Ver. 1.10	Ver. 1.12	
	GetECEError	Get EtherCAT Error Status	Changed	Ver. 1.02	Ver. 1.03	2-837
	ResetNXBEr-ror	Reset NX Bus Error	New	Ver. 1.13	Ver. 1.17	2-840
	GetNXBEr-ror	Get NX Bus Error Status	New	Ver. 1.13	Ver. 1.17	2-842
	GetNXUnitEr-ror	Get NX Unit Error Status	New	Ver. 1.13	Ver. 1.17	2-844
	RestartNXUnit	Restart NX Unit	New	Ver. 1.05	Ver. 1.06	2-860
			Changed	Ver. 1.07	Ver. 1.08	
	NX_ChangeWriteMode	Change to NX Unit Write Mode	New	Ver. 1.05	Ver. 1.06	2-866
	NX_SavePa-ram	Save NX Unit Parameters	New	Ver. 1.05	Ver. 1.06	2-871
NX_ReadTotalPowerOnTime	Read NX Unit Total Power ON Time	New	Ver. 1.10	Ver. 1.12	2-877	
PLC_ReadTo-talPowerOn-Time	Read PLC Total Power ON Time	New	Ver. 1.13	Ver. 1.17	2-885	
Program Control Instructions	PrgStart	Enable Program	New	Ver. 1.08	Ver. 1.09	2-890
	PrgStop	Disable Program	New	Ver. 1.08	Ver. 1.09	2-899
	PrgStatus	Read Program Status	New	Ver. 1.08	Ver. 1.09	2-919
EtherCAT Com-munications Instructions	EC_StartMon	Start EtherCAT Packet Monitor	Changed	Ver. 1.10	Ver. 1.12 ^{*1}	2-934
	EC_StopMon	Stop EtherCAT Packet Monitor	Changed	Ver. 1.10	Ver. 1.12 ^{*1}	2-940
	EC_SaveMon	Save EtherCAT Packets	Changed	Ver. 1.10	Ver. 1.12 ^{*1}	2-942
	EC_CopyMon	Transfer Ether-CAT Packets	Changed	Ver. 1.10	Ver. 1.12 ^{*1}	2-944
	EC_ChangeEnableSet-ting	Enable/Disable EtherCAT Slave	New	Ver. 1.04	Ver. 1.05	2-955
	NX_WriteObj	Write NX Unit Object	New	Ver. 1.05	Ver. 1.06	2-972
	NX_ReadObj	Read NX Unit Object	New	Ver. 1.05	Ver. 1.06	2-987
IO-Link Commu-nications Instruc-tions	IOL_ReadObj	Read IO-Link Device Object	New	Ver. 1.12	Ver. 1.16	2-998
	IOL_WriteObj	Write IO-Link Device Object	New	Ver. 1.12	Ver. 1.16	2-1007

Type	Instruction	Name	New/Changed	Versions		Page
				CPU Unit	Sysmac Studio	
EtherNet/IP Communications Instructions	CIPOpenWith-DataSize	Open CIP Class 3 Connection with Specified Data Size	New	Ver. 1.06	Ver. 1.07	2-1027
	CIPSend	Send Explicit Message Class 3	Changed	Ver. 1.11	Ver. 1.15	2-1043
	CIPUC-MMSend	Send Explicit Message UCMM	Changed	Ver. 1.11	Ver. 1.15	2-1063
	SktUDPCreate	Create UDP Socket	Changed	Ver. 1.03	---	2-1073
			Changed	Ver. 1.10	Ver. 1.13	
	SktTCPAccept	Accept TCP Socket	Changed	Ver. 1.03	---	2-1087
	SktTCPConnect	Connect TCP Socket	Changed	Ver. 1.03	---	2-1090
	SktSetOption	Set TCP Socket Option	New	Ver. 1.12 ^{*2}	Ver. 1.16 ^{*2}	2-1114
	ChangeIPAdr	Change IP Address	New	Ver. 1.02	Ver. 1.03	2-1119
			Changed	Ver. 1.10	Ver. 1.13	
	ChangeFTPAccount	Change FTP Account	New	Ver. 1.02	Ver. 1.03	2-1127
			Changed	Ver. 1.10	Ver. 1.13	
	ChangeNTPServerAdr	Change NTP Server Address	New	Ver. 1.02	Ver. 1.03	2-1131
			Changed	Ver. 1.10	Ver. 1.13	
	FTPGetFileList	Get FTP Server File List	New	Ver. 1.08	Ver. 1.09	2-1135
			Changed	Ver. 1.09	Ver. 1.10	
			Changed	Ver. 1.16	---	
	FTPGetFile	Get File from FTP Server	New	Ver. 1.08	Ver. 1.09	2-1152
			Changed	Ver. 1.09	Ver. 1.10	
			Changed	Ver. 1.16	---	
	FTPputFile	Put File onto FTP Server	New	Ver. 1.08	Ver. 1.09	2-1161
			Changed	Ver. 1.09	Ver. 1.10	
			Changed	Ver. 1.16	---	
FTPRemove-File	Delete FTP Server File	New	Ver. 1.08	Ver. 1.09	2-1172	
		Changed	Ver. 1.09	Ver. 1.10		
		Changed	Ver. 1.16	---		
FTPRemove-Dir	Delete FTP Server Directory	New	Ver. 1.08	Ver. 1.09	2-1182	
		Changed	Ver. 1.09	Ver. 1.10		
		Changed	Ver. 1.16	---		

Type	Instruction	Name	New/Changed	Versions		Page
				CPU Unit	Sysmac Studio	
Serial Communications Instructions	SerialRcvNoClear ^{*3}	SCU Receive Serial without Receive Buffer Clear	New	Ver. 1.03	Ver. 1.04	2-1212
	NX_SerialSend	Send No-protocol Data	New	Ver. 1.11	Ver. 1.15	2-1240
	NX_SerialRcv	Receive No-protocol Data	New	Ver. 1.11	Ver. 1.15	2-1253
	NX_ModbusRTUCmd	Send Modbus RTU General Command	New	Ver. 1.11	Ver. 1.15	2-1267
	NX_ModbusRTURead	Send Modbus RTU Read Command	New	Ver. 1.11	Ver. 1.15	2-1267
	NX_ModbusRTUWrite	Send Modbus RTU Write Command	New	Ver. 1.11	Ver. 1.15	2-1288
	NX_SerialSigCtl	Serial Control Signal ON/OFF Switching	New	Ver. 1.11	Ver. 1.15	2-1299
	NX_SerialSigRead	Read Serial Control Signal	New	Ver. 1.13	Ver. 1.17	2-1308
	NX_SerialStatusRead	Read Serial Port Status	New	Ver. 1.13	Ver. 1.17	2-1313
	NX_SerialBufClear	Clear Buffer	New	Ver. 1.11	Ver. 1.15	2-1318
	NX_SerialStartMon	Start Serial Line Monitoring	New	Ver. 1.11	Ver. 1.15	2-1328
	NX_SerialStopMon	Stop Serial Line Monitoring	New	Ver. 1.11	Ver. 1.15	2-1333
SD Memory Card Instructions	BackupToMemoryCard	SD Memory Card Backup	New	Ver.1.08	Ver.1.09	2-1417
Time Stamp Instructions	NX_DOutTimeStamp	Write Digital Output with Specified Time Stamp	New	Ver. 1.06	Ver. 1.07	2-1434
	NX_AryDOutTimeStamp	Write Digital Output Array with Specified Time Stamp	New	Ver. 1.06	Ver. 1.07	2-1440
Other Instructions	GetMyTaskInterval	Read Current Task Period	New	Ver.1.08	Ver.1.09	2-1459
	ActEventTask	Activate Event Task	New	Ver. 1.03	Ver. 1.04	2-1471

*1 For an NJ101 CPU Unit, Sysmac Studio version 1.13 or higher is required.

*2 For an NX1P2 CPU Unit, a CPU Unit with unit version 1.14 or later and Sysmac Studio version 1.18 or higher are required.

*3 A CPU Unit with unit version 1.03 or later, Sysmac Studio version 1.04 or higher, and a Serial Communications Unit with unit version 2.1 or later are required to use the SerialRcvNoClear instruction.

What to Do If An Error Message Says the Instruction May Cause Unintended Operations

The Sysmac Studio may display the following error message:

The instruction may cause unintended operations. Refer to the Instruction Reference Manual for details.

The message is the results of restrictions in the user program. The user program may need to be corrected.

This appendix describes the conditions under which this error message may be displayed and how to correct the user program.

Version Information

This error message is displayed only for Sysmac Studio version 1.02.

Conditions for Display of the Error Message

The error message is displayed when an in-out variable in a function or function block is passed to a specific variable of a specific instruction within the same function or function block.

A table of the instructions and variables for which the error message is displayed is given later in this appendix.

Programming Example for Which the Error Message Is Displayed

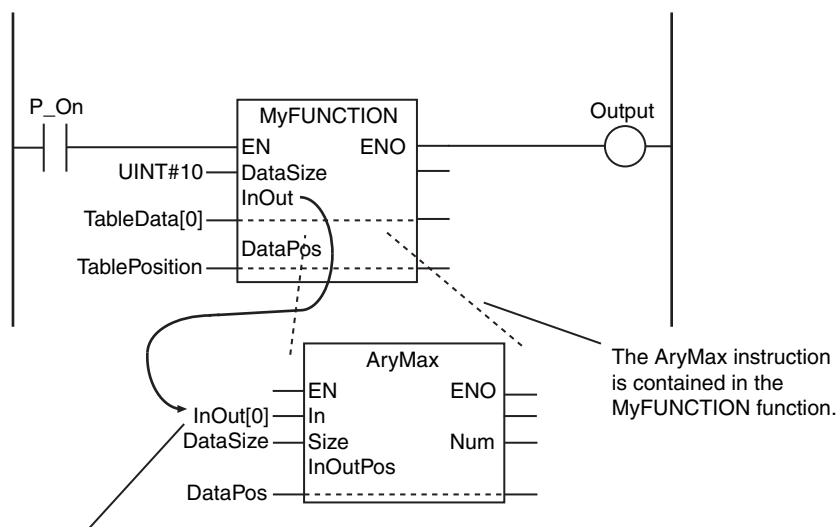

In this example, the *InOut* in-out variable of *MyFUNCTION* is passed to the *In* variable of the *AryMax* instruction.

Instructions and Variables for Which the Error Message Is Displayed

This error message is displayed only for specific variables of specific instructions. These are listed in the following table.

Type	Instruction	Name	Function	Page
Comparison Instructions	TableCmp	Table Comparison	Table and AryOut	2-111
	AryCmpEQ	Array Comparison Equal	In1, In2, and AryOut	2-114
	AryCmpNE	Array Comparison Not Equal	In1, In2, and AryOut	2-114
	AryCmpLT	Array Comparison Less Than	In1, In2, and AryOut	2-116
	AryCmpLE	Array Comparison Less Than Or Equal	In1, In2, and AryOut	2-116
	AryCmpGT	Array Comparison Greater Than	In1, In2, and AryOut	2-116
	AryCmpGE	Array Comparison Greater Than Or Equal	In1, In2, and AryOut	2-116
	AryCmpEQV	Array Value Comparison Equal	In1 and AryOut	2-119
	AryCmpNEV	Array Value Comparison Not Equal	In1 and AryOut	2-119
	AryCmpLTV	Array Value Comparison Less Than	In1 and AryOut	2-121
	AryCmpLEV	Array Value Comparison Less Than Or Equal	In1 and AryOut	2-121
	AryCmpGTV	Array Value Comparison Greater Than	In1 and AryOut	2-121
	AryCmpGEV	Array Value Comparison Greater Than Or Equal	In1 and AryOut	2-121
Math Instructions	AryAdd	Array Addition	In1, In2, and AryOut	2-221
	AryAddV	Array Value Addition	In1 and AryOut	2-223
	ArySub	Array Subtraction	In1, In2, and AryOut	2-225
	ArySubV	Array Value Subtraction	In1 and AryOut	2-227
	AryMean	Array Mean	In	2-229
	ArySD	Array Element Standard Deviation	In	2-231
BCD Conversion Instructions	AryToBCD	Array BCD Conversion	In and AryOut	2-256
	AryToBin	Array Unsigned Integer Conversion	In and AryOut	2-258
Bit String Processing Instructions	AryAnd	Array Logical AND	In1, In2, and AryOut	2-327
	AryOr	Array Logical OR	In1, In2, and AryOut	2-327
	AryXor	Array Logical Exclusive OR	In1, In2, and AryOut	2-327
	AryXorN	Array Logical Exclusive NOR	In1, In2, and AryOut	2-327
Selection Instructions	AryMax	Array Maximum	In	2-347
	AryMin	Array Minimum	In	2-347
	ArySearch	Array Search	In	2-350
Data Movement Instructions	TransBits	Move Bits	InOut	2-357
	AryExchange	Array Data Exchange	InOut1 and InOut2	2-369
	AryMove	Array Move	In and AryOut	2-371
	Clear	Initialize	InOut	2-373
Shift Instructions	AryShiftReg	Shift Register	InOut	2-388
	AryShiftRegLR	Reversible Shift Register	InOut	2-390
	ArySHL	Array N-element Left Shift	InOut	2-393
	ArySHR	Array N-element Right Shift	InOut	2-393
	NSHLC	Shift N-bits Left with Carry	InOut	2-398
	NSHRC	Shift N-bits Right with Carry	InOut	2-398

Type	Instruction	Name	Function	Page
Conversion Instructions	Decoder	Bit Decoder	InOut	2-407
	Encoder	Bit Encoder	In	2-410
	ColmToLine_**	Column to Line Conversion Group	In	2-413
	LineToColm	Line to Column Conversion	InOut	2-415
	PWLApprox	Broken Line Approximation	Line	2-426
	MovingAverage	Moving Average	Buf	2-435
	StringToAry	Text String-to-Array Conversion	AryOut	2-463
	AryToString	Array-to-Text String Conversion	In	2-465
	DispartDigit	Four-bit Separation	AryOut	2-467
	UniteDigit_**	Four-bit Join Group	In	2-469
	Dispart8Bit	Byte Data Separation	AryOut	2-471
	Unite8Bit_**	Byte Data Join Group	In	2-473
	ToAryByte	Conversion to Byte Array	In and AryOut	2-475
	AryByteTo	Conversion from Byte Array	In and OutVal	2-480
SizeOfAry	Get Number of Array Elements	In	2-485	
Stack and Table Instructions	StackPush	Push onto Stack	InOut	2-492
	StackFIFO	First In First Out	InOut and OutVal	2-501
	StackLIFO	Last In First Out	InOut and OutVal	2-501
	StackIns	Insert into Stack	InOut	2-504
	StackDel	Delete from Stack	InOut	2-506
	RecSearch	Record Search	In, Member, and InOutPos	2-508
	RecRangeSearch	Range Record Search	In, Member, and InOutPos	2-513
	RecSort	Record Sort	InOut and Member	2-518
	RecNum	Get Number of Records	In and Member	2-524
	RecMax	Maximum Record Search	In, Member, and InOutPos	2-526
	RecMin	Minimum Record Search	In, Member, and InOutPos	2-526
FCS Instructions	AryLRC_**	Calculate Array LRC Group	In	2-540
	AryCRCCITT	Calculate Array CRC-CCITT	In	2-542
	AryCRC16	Calculate Array CRC-16	In	2-544
System Control Instructions	SetAlarm	Create User-defined Error	Info1 and Info2	2-808
	SetInfo	Create User-defined Information	Info1 and Info2	2-852
EtherCAT Communications Instructions	EC_CoESDOWrite	Write EtherCAT CoE SDO	WriteDat	2-926
	EC_CoESDORead	Read EtherCAT CoE SDO	ReadDat	2-929
EtherNet/IP Communications Instructions	CIPRead	Read Variable Class 3 Explicit	DstDat	2-1031
	CIPWrite	Write Variable Class 3 Explicit	SrcDat	2-1037
	CIPSend	Send Explicit Message Class 3	ServiceDat and RespServiceDat	2-1043
	CIPUCMMRead	Read Variable UCMM Explicit	DstDat	2-1051
	CIPUCMMWrite	Write Variable UCMM Explicit	SrcDat	2-1056
	CIPUCMMSend	Send Explicit Message UCMM	ServiceDat and RespServiceDat	2-1063
	SkUDPRcv	UDP Socket Receive	RcvDat	2-1081
	SkUDPSend	UDP Socket Send	SendDat	2-1084
	SkTCPRcv	TCP Socket Receive	RcvDat	2-1099
	SkTCPSend	TCP Socket Send	SendDat	2-1102
Serial Communications Instructions	ExecPMCR	Protocol Macro	SrcDat and DstDat	2-1188
	SerialSend	SCU Send Serial	SrcDat	2-1201
	SerialRcv	SCU Receive Serial	DstDat	2-1212
	SendCmd	Send Command	CmdDat and RespDat	2-1227

Type	Instruction	Name	Function	Page
SD Memory Card Instructions	FileWriteVar	Write Variable to File	WriteVar	2-1338
	FileReadVar	Read Variable from File	ReadVar	2-1343
	FileRead	Read File	ReadBuf	2-1359
	FileWrite	Write File	WriteBuf	2-1367
Motion Control Instructions	MC_SetCamTableProperty	Set Cam Table Properties	CamTable	*
	MC_SaveCamTable	Save Cam Table	CamTable	*
	MC_Write	Write MC Setting	Target and SettingValue	*
	MC_CamIn	Start Cam Operation	CamTable	*
	MC_ChangeAxesInGroup	Change Axes in Group	Axes	*
Other Instructions	ChkRange	Check Subrange Variable	Val	2-1454

* Refer to the *NJ/NX-series Motion Control Instructions Reference Manual* (Cat. No. W508) for details.

Correcting the User Program

The user program must be corrected so that the error message is not displayed. There are two ways to correct the user program.

- Copy the in-out variable to an internal variable in the function or function block and then pass the internal variable to the instruction.
- Place the instruction outside of the function or function block.

Both of these methods are described below.

● Passing the In-Out Variable to an Internal Variable

Do not pass the in-out variable of the function or function block directly to the instruction. Copy it to an internal variable first. If the value of the internal variable changes when the instruction is executed, the internal variable is then copied back to the in-out variable after the instruction is executed.

However, this method cannot be used for the Clear instruction. To use the Clear instruction, place it outside the function or function block.

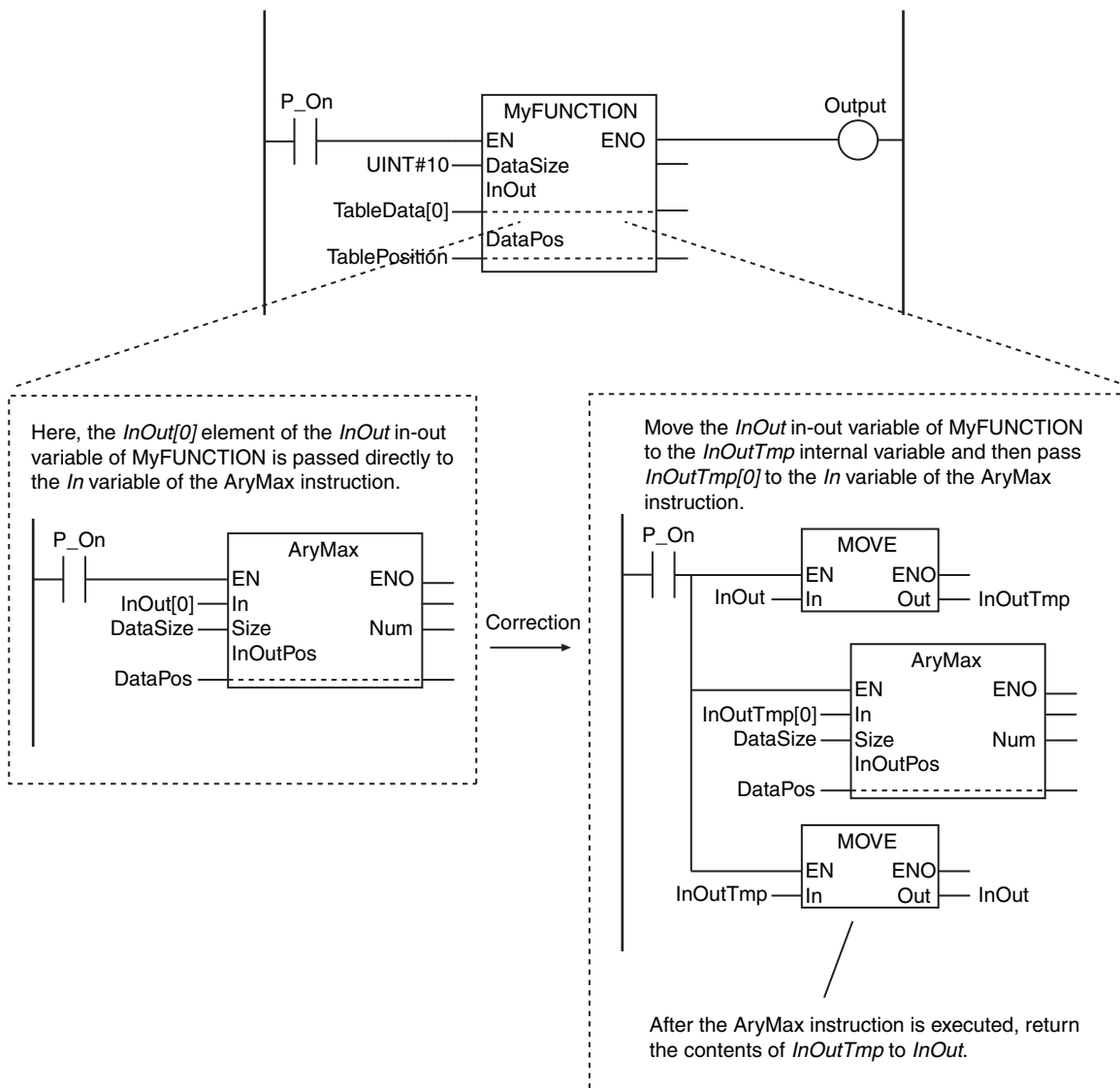

● **Placing the Instruction Outside of the Function or Function Block**

You can correct the problem by placing the instruction outside of the function or function block instead of inside it.

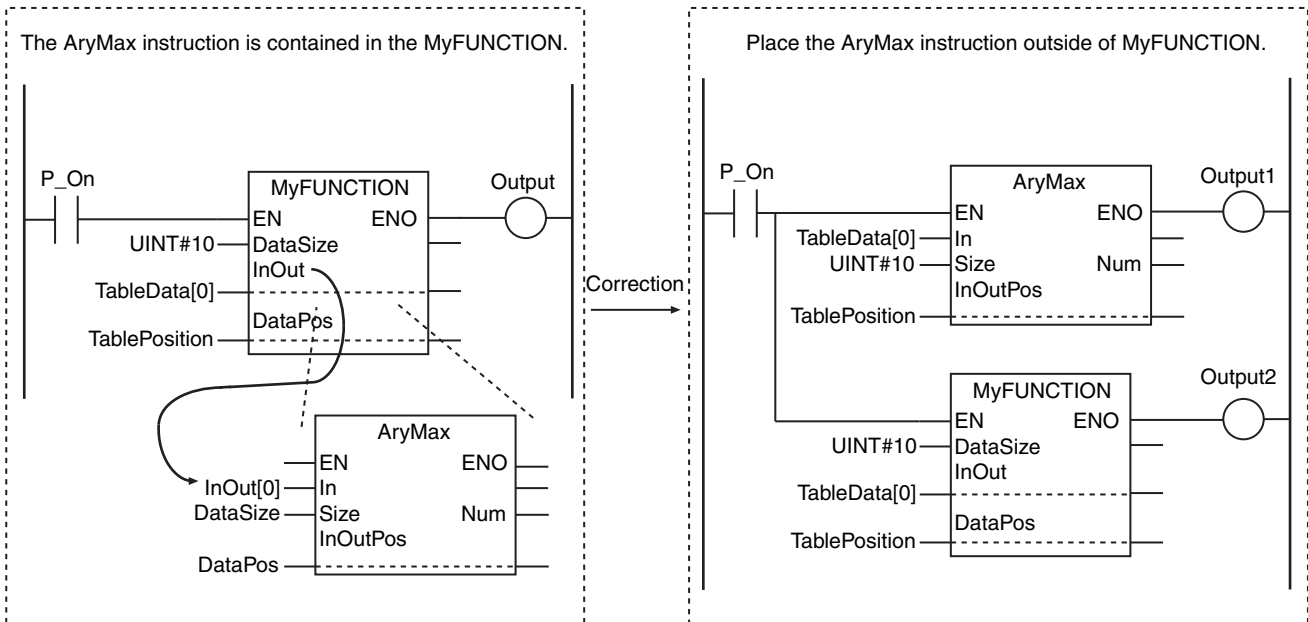

When the Error Message Can Be Ignored

Even if the error message is displayed, there are cases when the instruction can be used without any problems. Whether the instruction can be used depends on the parameter that is passed to the in-out variable of the function of function block. These conditions are listed in the following table.

Applicability of instruction	Parameter passed to in-out variable of function of function block
Can be used.	Basic data type, enumeration, array, structure, or union
Cannot be used.	One element of an array, or one member of a structure or union

● **Example in Which the Instruction Can Be Used**

In this example, an array is passed to the in-out variable of a function or function block and then used in an instruction inside the function or function block.

Variables Called by MyFUNCTION

Variable	Data type
DintArray	ARRAY[0..9] OF DINT

Variables in MyFUNCTION

Variable	Data type
InOut	ARRAY[0..9] OF DINT

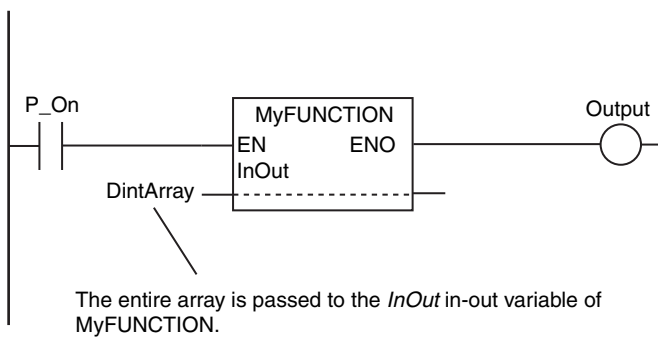

In this example, an structure is passed to the in-out variable of a function or function block and then used in an instruction inside the function or function block.

Variable Called by MyFUNCTION

Variable	Data type
StructVar	STRUCT

Variable in MyFUNCTION

Variable	Data type
InOut	STRUCT

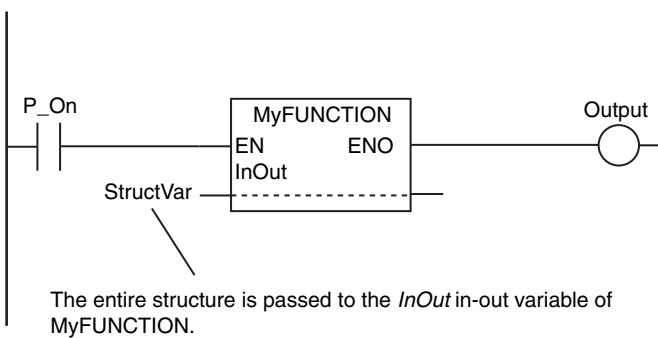

● **Example in Which the Instruction Cannot Be Used**

In the following example, one element of an array is passed to the in-out variable of a function or function block, so the instruction cannot be used inside the function or function block.

Variable Called by MyFUNCTION

Variable	Data type
DintArray	ARRAY[0..9] OF DINT

Variable in MyFUNCTION

Variable	Data type
InOut	DINT

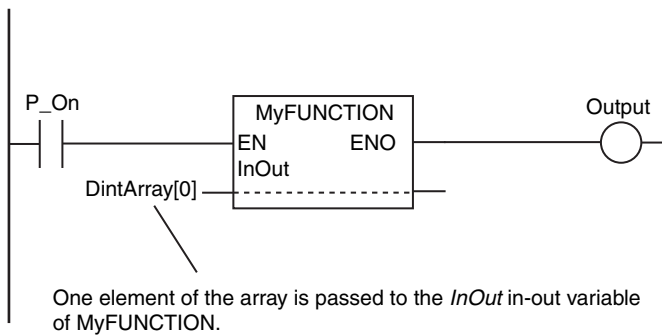

In the following example, one member of a structure is passed to the in-out variable of a function or function block, so the instruction cannot be used inside the function or function block.

Variable Called by MyFUNCTION

Variable	Data type
StructVar	STRUCT

Variable in MyFUNCTION

Variable	Data type
InOut	DINT

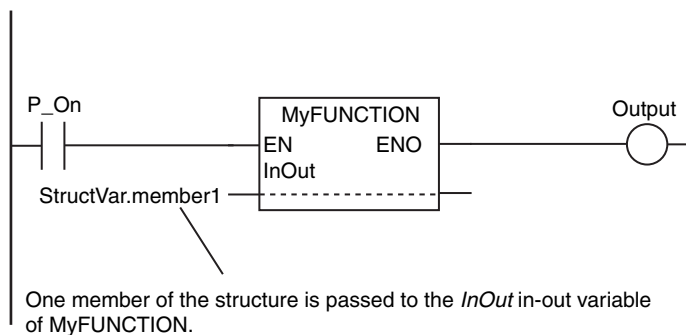

Option Setting for Error Detection

As described above, there are cases when the instruction can be used even if the error message is displayed. There is an option in the Sysmac Studio that you can use to enable or disable detection of this error.

To prevent detection of this error, display the option settings on the Sysmac Studio and clear the selection of the *Detect an error when an in-out variable is passed to a specific instruction argument* Check Box in the *Program Check Area*. Refer to the *Sysmac Studio Version 1 Operation Manual* (Cat. No. W504-E1-03 or later) for the specific procedure.

However, before you disable detection of this error, make sure that all of the instructions in the user program can be used. Even if detection of this error is disabled, the same message will be displayed as a warning.

Caution

If you clear the selection of this option, unexpected operation may occur for the instructions and the system may be affected. Always confirm that the conditions for use that are given in *When the Error Message Can Be Ignored* on page A-226 are met before you clear the selection of this option.



Version Information

This error message is displayed and the above option setting is available only for Sysmac Studio version 1.02.



Index



Index

Symbols

- (Subtraction)	2-174
-OU (Subtraction with Overflow Check)	2-177
* (Multiplication)	2-181
** (Exponentiation)	2-211
_BCD_TO_* (BCD-to-Unsigned Integer Conversion Group)	2-242
TO* (Bit String-to-Bit String Conversion Group)	2-272
TO* (Bit String-to-Integer Conversion Group)	2-270
TO* (Bit String-to-Real Number Conversion Group)	2-274
TO* (Integer-to-Bit String Conversion Group)	2-265
TO* (Integer-to-Integer Conversion Group)	2-262
TO* (Integer-to-Real Number Conversion Group)	2-268
TO* (Real Number-to-Bit String Conversion Group)	2-279
TO* (Real Number-to-Integer Conversion Group)	2-276
TO* (Real Number-to-Real Number Conversion Group)	2-281
_TO_BCD_* (Unsigned Integer-to-BCD Conversion Group)	2-245
**_TO_STRING (Bit String-to-Text String Conversion Group)	2-285
**_TO_STRING (Integer-to-Text String Conversion Group)	2-283
**_TO_STRING (Real Number-to-Text String Conversion Group)	2-287
/ (Division)	2-189
& (Logical AND)	2-320
+ (Addition)	2-166
+OU (Addition with Overflow Check)	2-170
< (Less Than)	2-97
<= (Less Than Or Equal)	2-97
<> (Not Equal)	2-94
= (Equal)	2-92
> (Greater Than)	2-97
>= (Greater Than Or Equal)	2-97

Numerics

2-byte Join	2-487
4-byte Join	2-489

A

ABS (Absolute Value)	2-194
Absolute Value	2-194

Accept TCP Socket	2-1087
Accumulation Timer	2-138
AccumulationTimer (Accumulation Timer)	2-138
ACOS (Principal Arc Cosine)	2-201
AC_StepProgram (Step Program)	2-772
ActEventTask (Activate Event Task)	2-1471
Activate Event Task	2-1471
ADD (Addition)	2-166
Add Time	2-594
Add Time to Date and Time	2-598
Add Time to Time of Day	2-596
AddDelimiter (Put Text Strings with Delimiters)	2-571
ADD_DT_TIME (Add Time to Date and Time)	2-598
Addition	2-166
Addition with Overflow Check	2-170
AddOU (Addition with Overflow Check)	2-170
ADD_TIME (Add Time)	2-594
ADD_TOD_TIME (Add Time to Time of Day)	2-596
AND	2-18
AND (AND)	2-18
AND (Logical AND)	2-320
AND NOT	2-18
ANDN (AND NOT)	2-18
Array Addition	2-221
Array BCD Conversion	2-256
Array Comparison Equal	2-114
Array Comparison Greater Than	2-116
Array Comparison Greater Than Or Equal	2-116
Array Comparison Less Than	2-116
Array Comparison Less Than Or Equal	2-116
Array Comparison Not Equal	2-114
Array Data Exchange	2-369
Array Element Standard Deviation	2-231
Array Logical AND	2-327
Array Logical Exclusive NOR	2-327
Array Logical Exclusive OR	2-327
Array Logical OR	2-327
Array Maximum	2-347
Array Mean	2-229
Array Minimum	2-347
Array Move	2-371
Array N-element Left Shift	2-393
Array N-element Right Shift	2-393
Array Search	2-350
Array Subtraction	2-225
Array Unsigned Integer Conversion	2-258
Array Value Addition	2-223
Array Value Comparison Equal	2-119
Array Value Comparison Greater Than	2-121
Array Value Comparison Greater Than Or Equal	2-121
Array Value Comparison Less Than	2-121
Array Value Comparison Less Than Or Equal	2-121
Array Value Comparison Not Equal	2-119
Array Value Subtraction	2-227
Array-to-Text String Conversion	2-465

AryAdd (Array Addition) 2-221
 AryAddV (Array Value Addition) 2-223
 AryAnd (Array Logical AND) 2-327
 AryByteTo (Conversion from Byte Array) 2-480
 AryCmpEQ (Array Comparison Equal) 2-114
 AryCmpEQV (Array Value Comparison Equal) 2-119
 AryCmpGE
 (Array Comparison Greater Than Or Equal) 2-116
 AryCmpGEV
 (Array Value Comparison Greater Than Or Equal) 2-121
 AryCmpGT (Array Comparison Greater Than) 2-116
 AryCmpGTV
 (Array Value Comparison Greater Than) 2-121
 AryCmpLE
 (Array Comparison Less Than Or Equal) 2-116
 AryCmpLEV
 (Array Value Comparison Less Than Or Equal) 2-121
 AryCmpLT (Array Comparison Less Than) 2-116
 AryCmpLTV (Array Value Comparison Less Than) ... 2-121
 AryCmpNE (Array Comparison Not Equal) 2-114
 AryCmpNEV (Array Value Comparison Not Equal) .. 2-119
 AryCRC16 (Calculate Array CRC-16) 2-544
 AryCRCCITT (Calculate Array CRC-CCITT) 2-542
 AryExchange (Array Data Exchange) 2-369
 AryLRC_** (Calculate Array LRC Group) 2-540
 AryMax (Array Maximum) 2-347
 AryMean (Array Mean) 2-229
 AryMin (Array Minimum) 2-347
 AryMove (Array Move) 2-371
 AryOr (Array Logical OR) 2-327
 ArySD (Array Element Standard Deviation) 2-231
 ArySearch (Array Search) 2-350
 AryShiftReg (Shift Register) 2-388
 AryShiftRegLR (Reversible Shift Register) 2-390
 ArySHL (Array N-element Left Shift) 2-393
 ArySHR (Array N-element Right Shift) 2-393
 ArySub (Array Subtraction) 2-225
 ArySubV (Array Value Subtraction) 2-227
 AryToBCD (Array BCD Conversion) 2-256
 AryToBin (Array Unsigned Integer Conversion) 2-258
 AryToString (Array-to-Text String Conversion) 2-465
 AryXor (Array Logical Exclusive OR) 2-327
 AryXorN (Array Logical Exclusive NOR) 2-327
 ASIN (Principal Arc Sine) 2-201
 ATAN (Principal Arc Tangent) 2-201

B

BackupToMemoryCard (SD Memory Card Backup) 2-1417
 Band (Deadband Control) 2-339
 BCD Data Type-to-Unsigned Integer
 Conversion Group 2-247
 BCDsToBin
 (Signed BCD-to-Signed Integer Conversion) 2-250
 BCD_TO_** (BCD Data Type-to-Unsigned Integer
 Conversion Group) 2-247
 BCD-to-Unsigned Integer Conversion Group 2-242
 Binary Code-to-Gray Code Conversion 2-461
 Binary Selection 2-332

BinToBCDs_**
 (Signed Integer-to-BCD Conversion Group) 2-253
 BinToGray_**
 (Binary Code-to-Gray Code Conversion) 2-461
 Bit Counter 2-412
 Bit Decoder 2-407
 Bit Encoder 2-410
 Bit Pattern Copy
 (Bit String to Real Number) Group 2-377
 Bit Pattern Copy
 (Bit String to Signed Integer) Group 2-375
 Bit Pattern Copy
 (Real Number to Bit String) Group 2-383
 Bit Pattern Copy
 (Real Number to Signed Integer) Group 2-385
 Bit Pattern Copy
 (Signed Integer to Bit String) Group 2-379
 Bit Pattern Copy
 (Signed Integer to Real Number) Group 2-381
 Bit Reversal 2-325
 Bit String Conversion Group 2-308
 Bit String-to-Bit String Conversion Group 2-272
 Bit String-to-Integer Conversion Group 2-270
 Bit String-to-Real Number Conversion Group 2-274
 Bit String-to-Text String Conversion Group 2-285
 BitCnt (Bit Counter) 2-412
 Block Set 2-365
 BREAK (Break Loop) 2-89
 Break Down Date and Time 2-648
 Break Loop 2-89
 Broken Line Approximation
 with Broken Line Data Check 2-426
 Broken Line Approximation
 without Broken Line Data Check 2-426
 Broken Line Data Check 2-432
 Byte Data Join Group 2-473
 Byte Data Separation 2-471

C

Calculate Array CRC-16 2-544
 Calculate Array CRC-CCITT 2-542
 Calculate Array LRC Group 2-540
 Calculate Text String CRC-16 2-538
 Calculate Text String CRC-CCITT 2-536
 Calculate Text String LRC 2-534
 Case 2-30
 CASE (Case) 2-30
 Change File Name 2-1406
 Change FTP Account 2-1127
 Change IP Address 2-1119
 Change NTP Server Address 2-1131
 Change to NX Unit Write Mode 2-866
 ChangeFTPAccount (Change FTP Account) 2-1127
 ChangeIPAdr (Change IP Address) 2-1119
 ChangeNTPAdr (Change NTP Server Address) 2-1131
 Check for Leap Year 2-639
 Check Subrange Variable 2-1454
 CheckReal (Real Number Check) 2-237

- Checksum Calculation 2-532
- ChkLeapYear (Check for Leap Year) 2-639
- ChkRange (Check Subrange Variable) 2-1454
- CIPClose (Close CIP Class 3 Connection) 2-1048
- CIPOpen (Open CIP Class 3 Connection) 2-1018
- CIPOpenWithDataSize (Open CIP Class 3
Connection with Specified Data Size) 2-1027
- CIPRead (Read Variable Class 3 Explicit) 2-1031
- CIPSend (Send Explicit Message Class 3) 2-1043
- CIPUCMM Read (Read Variable UCMM Explicit) .. 2-1051
- CIPUCMM Send (Send Explicit Message UCMM) .. 2-1063
- CIPUCMM Write (Write Variable UCMM Explicit) ... 2-1056
- CIPWrite (Write Variable Class 3 Explicit) 2-1037
- Clear (Initialize) 2-373
- Clear Buffer 2-1318
- Clear String 2-565
- Clear TCP/UDP Socket Receive Buffer 2-1111
- ClearString (Clear String) 2-565
- Close CIP Class 3 Connection 2-1048
- Close File 2-1352
- Close TCP/UDP Socket 2-1108
- Cmp (Compare) 2-107
- ColmToLine_**
(Column to Line Conversion Group) 2-413
- Column to Line Conversion Group 2-413
- Combine Real Number Mantissa and Exponent 2-444
- Compare 2-107
- CONCAT (Concatenate String) 2-548
- CONCAT_DATE_TOD
(Concatenate Date and Time of Day) 2-614
- Concatenate Date and Time of Day 2-614
- Concatenate String 2-548
- Connect EtherCAT Slave 2-953
- Connect TCP Socket 2-1090
- Conversion from Byte Array 2-480
- Conversion to Byte Array 2-475
- Convert Date and Time to Seconds 2-624
- Convert Date to Seconds 2-626
- Convert Days to Month 2-642
- Convert Nanoseconds to Time 2-636
- Convert Seconds to Date 2-630
- Convert Seconds to Date and Time 2-628
- Convert Seconds to Time 2-637
- Convert Seconds to Time of Day 2-632
- Convert Time of Day to Seconds 2-627
- Convert Time to Nanoseconds 2-634
- Convert Time to Seconds 2-635
- Convert to Lowercase 2-567
- Convert to Uppercase 2-567
- Copy File 2-1392
- Copy**To*** (Bit Pattern Copy
(Bit String to Real Number) Group) 2-377
- Copy**To*** (Bit Pattern Copy
(Real Number to Bit String) Group) 2-383
- Copy**ToNum (Bit Pattern Copy
(Bit String to Signed Integer) Group) 2-375
- Copy**ToNum (Bit Pattern Copy
(Real Number to Signed Integer) Group) 2-385
- CopyNumTo** (Bit Pattern Copy
(Signed Integer to Bit String) Group) 2-379
- CopyNumTo** (Bit Pattern Copy
(Signed Integer to Real Number) Group) 2-381
- COS (Cosine in Radians) 2-198
- Cosine in Radians 2-198
- Create Directory 2-1411
- Create UDP Socket 2-1073
- Create User-defined Error 2-808
- Create User-defined Information 2-852
- CTD (Down-counter) 2-146
- CTD_** (Down-counter Group) 2-148
- CTU (Up-counter) 2-150
- CTU_** (Up-counter Group) 2-152
- CTUD (Up-down Counter) 2-155
- CTUD_** (Up-down Counter Group) 2-159

D

- Data Exchange 2-367
- Data Trace Sampling 2-798
- Data Trace Trigger 2-801
- Date and Time-to-Text String Conversion 2-456
- DateStructToDt (Join Time) 2-650
- DateToSec (Convert Date to Seconds) 2-626
- DateToString (Date-to-Text String Conversion) 2-458
- Date-to-Text String Conversion 2-458
- DaysToMonth (Convert Days to Month) 2-642
- Dead Zone Control 2-342
- Deadband Control 2-339
- Dec (Decrement) 2-217
- Decoder (Bit Decoder) 2-407
- Decrement 2-217
- Degrees to Radians 2-196
- DegToRad (Degrees to Radians) 2-196
- DELETE (Delete String) 2-559
- Delete Directory 2-1414
- Delete File 2-1401
- Delete from Stack 2-506
- Delete String 2-559
- Determine Task Status 2-1462
- DirCreate (Create Directory) 2-1411
- DirRemove (Delete Directory) 2-1414
- Disable Program 2-899
- Disconnect EtherCAT Slave 2-946
- Dispart8Bit (Byte Data Separation) 2-471
- DispartDigit (Four-bit Separation) 2-467
- DispartReal (Separate Mantissa and Exponent) 2-441
- DIV (Division) 2-189
- Divide Time 2-612
- Division 2-189
- DIVTIME (Divide Time) 2-612
- Down (Down Trigger) 2-44
- Down Trigger 2-44
- Down-counter 2-146
- Down-counter Group 2-148
- DT_TO_DATE (Extract Date from Date and Time) 2-618
- DtToDateStruct (Break Down Date and Time) 2-648
- DtToSec (Convert Date and Time to Seconds) 2-624

DtToString
 (Date and Time-to-Text String Conversion) 2-456
 DT_TO_TOD
 (Extract Time of Day from Date and Time) 2-616

E

EC_ChangeEnableSetting (Enable/Disable EtherCAT Slave) 2-955
 EC_CoESDORead (Read EtherCAT CoE SDO) 2-929
 EC_CoESDOWrite (Write EtherCAT CoE SDO) 2-926
 EC_ConnectSlave (Connect EtherCAT Slave) 2-953
 EC_CopyMon (Transfer EtherCAT Packets) 2-944
 EC_DisconnectSlave (Disconnect EtherCAT Slave) . 2-946
 EC_SaveMon (Save EtherCAT Packets) 2-942
 EC_StartMon (Start EtherCAT Packet Monitor) 2-934
 EC_StopMon (Stop EtherCAT Packet Monitor) 2-940
 Enable Program 2-890
 Encoder (Bit Encoder) 2-410
 End 2-66
 End (End) 2-66
 Enumeration-to-Integer 2-312
 EnumToNum (Enumeration-to-Integer) 2-312
 EQ (Equal) 2-92
 EQascii (Text String Comparison Equal) 2-100
 Equal 2-92
 Exchange (Data Exchange) 2-367
 ExecPMCR (Protocol Macro) 2-1188
 EXP (Natural Exponential Operation) 2-209
 Exponentiation 2-211
 EXPT (Exponentiation) 2-211
 Extract Date from Date and Time 2-618
 Extract Time of Day from Date and Time 2-616

F

FileClose (Close File) 2-1352
 FileCopy (Copy File) 2-1392
 FileGets (Get Text String) 2-1375
 FileOpen (Open File) 2-1348
 FilePuts (Put Text String) 2-1383
 FileRead (Read File) 2-1359
 FileReadVar (Read Variable from File) 2-1343
 FileRemove (Delete File) 2-1401
 FileRename (Change File Name) 2-1406
 FileSeek (Seek File) 2-1355
 FileWrite (Write File) 2-1367
 FileWriteVar (Write Variable to File) 2-1338
 FIND (Find String) 2-554
 Find String 2-554
 First In First Out 2-501
 Fixed-decimal Number-to-Text String Conversion 2-451
 Fixed-length Decimal Text String Conversion 2-446
 Fixed-length Hexadecimal Text String Conversion 2-446
 FixNumToString
 (Fixed-decimal Number-to-Text String Conversion) 2-451
 FOR (Repeat Start) 2-82
 Four-bit Join Group 2-469
 Four-bit Separation 2-467

Fraction (Real Number Fraction) 2-235
 FTPGetFile (Get File from FTP Server) 2-1152
 FTPGetFileList (Get FTP Server File List) 2-1135
 FTPPutFile (Put File onto FTP Server) 2-1161
 FTPRemoveDir (Delete FTP Server Directory) 2-1182
 FTPRemoveFile (Delete FTP Server File) 2-1172
 F_TRIG (Down Trigger) 2-44

G

GE (Greater Than Or Equal) 2-97
 GEascii
 (Text String Comparison Greater Than or Equal) ... 2-104
 Get Byte Length 2-563
 Get Clock Pulse Group 2-1477
 Get Days in Month 2-640
 Get EtherCAT Error Status 2-837
 Get EtherNet/IP Error Status 2-826
 Get I/O Bus Error Status 2-824
 Get Incrementing Free-running Counter Group 2-1478
 Get Motion Control Error Status 2-833
 Get Number of Array Elements 2-485
 Get Number of Records 2-524
 Get NX Bus Error Status 2-842
 Get NX Unit Error Status 2-844
 Get PLC Controller Error Status 2-820
 Get String Any 2-552
 Get String Left 2-550
 Get String Right 2-550
 Get Text String 2-1375
 Get Text Strings Minus Delimiters 2-582
 Get Time of Day 2-622
 Get User-defined Error Status 2-815
 Get**Clk (Get Clock Pulse Group) 2-1477
 Get**Cnt
 (Get Incrementing Free-running Counter Group) . 2-1478
 GetAlarm (Get User-defined Error Status) 2-815
 GetByteLen (Get Byte Length) 2-563
 GetCJBError (Get I/O Bus Error Status) 2-824
 GetDayOfWeek (Get Day of Week) 2-644
 GetDaysOfMonth (Get Days in Month) 2-640
 GetECError (Get EtherCAT Error Status) 2-837
 GetEIPError (Get EtherNet/IP Error Status) 2-826
 GetMCError (Get Motion Control Error Status) 2-833
 GetMyTaskInterval (Read Current Task Period) 2-1459
 GetMyTaskStatus (Read Current Task Status) 2-1456
 GetNTPStatus (Read NTP Status) 2-858
 GetNXBError (Get NX Bus Error Status) 2-842
 GetNXUnitError (Get NX Unit Error Status) 2-844
 GetPLCError (Get PLC Controller Error Status) 2-820
 GetTime (Get Time of Day) 2-622
 GetTraceStatus (Read Data Trace Status) 2-804
 GetWeekOfYear (Get Week Number) 2-646
 Gray (Gray Code Conversion) 2-417
 Gray Code Conversion 2-417
 Gray Code-to-Binary Code Conversion Group 2-461
 GrayToBin_**
 (Gray Code-to-Binary Code Conversion Group) 2-461
 Greater Than 2-97

Greater Than Or Equal 2-97
 GT (Greater Than) 2-97
 GTascii (Text String Comparison Greater Than) 2-104

H

Hexadecimal Text String-to-Number
 Conversion Group 2-449
 HexStringToNum_** (Hexadecimal Text
 String-to-Number Conversion Group) 2-449
 Hundred-ms Timer 2-141

I

If 2-26
 IF (If) 2-26
 Inc (Increment) 2-217
 Increment 2-217
 Initialize 2-373
 INSERT (Insert String) 2-561
 Insert into Stack 2-504
 Insert String 2-561
 Integer Conversion Group 2-306
 Integer-to-Bit String Conversion Group 2-265
 Integer-to-Enumeration 2-314
 Integer-to-Integer Conversion Group 2-262
 Integer-to-Real Number Conversion Group 2-268
 Integer-to-Text String Conversion Group 2-283
 IOL_ReadObj (Read IO-Link Device Object) 2-998
 IOL_WriteObj (Write IO-Link Device Object) 2-1007

J

JMP (Jump) 2-80
 Join Time 2-650
 Jump 2-80

L

Last In First Out 2-501
 LD (Load) 2-16
 LDN (Load NOT) 2-16
 LE (Less Than Or Equal) 2-97
 LEascii
 (Text String Comparison Less Than or Equal) 2-104
 LEFT (Get String Left) 2-550
 LEN (String Length) 2-556
 Less Than 2-97
 Less Than Or Equal 2-97
 LIMIT (Limiter) 2-337
 LimitAlarm_**
 (Upper/Lower Limit Alarm Group) 2-745
 LimitAlarmDv_**
 (Upper/Lower Deviation Alarm Group) 2-749
 LimitAlarmDvStbySeq_** (Upper/Lower Deviation Alarm
 with Standby Sequence Group) 2-754
 Limiter 2-337
 Line to Column Conversion 2-415
 LineToColm (Line to Column Conversion) 2-415

LN (Natural Logarithm) 2-206
 Load 2-16
 Load NOT 2-16
 Lock (Lock Tasks) 2-1464
 Lock Tasks 2-1464
 LOG (Logarithm Base 10) 2-206
 Logarithm Base 10 2-206
 Logical AND 2-320
 Logical Exclusive OR 2-320
 Logical OR 2-320
 LrealToFormatString
 (LREAL-to-Formatted Text String) 2-294
 LREAL-to-Formatted Text String 2-294
 LT (Less Than) 2-97
 LTascii (Text String Comparison Less Than) 2-104

M

Master Control End 2-68
 Master Control Start 2-68
 MAX (Maximum) 2-345
 Maximum 2-345
 Maximum Record Search 2-526
 MC (Master Control Start) 2-68
 MCR (Master Control End) 2-68
 MemCopy (Memory Copy) 2-363
 Memory Copy 2-363
 MID (Get String Any) 2-552
 MIN (Minimum) 2-345
 Minimum 2-345
 Minimum Record Search 2-526
 MOD (Modulo-division) 2-192
 ModReal (Real Number Modulo-division) 2-233
 Modulo-division 2-192
 Move 2-354
 MOVE (Move) 2-354
 Move Bit 2-357
 Move Bits 2-361
 Move Digit 2-359
 MoveBit (Move Bit) 2-357
 MoveDigit (Move Digit) 2-359
 Moving Average 2-435
 MovingAverage (Moving Average) 2-435
 MUL (Multiplication) 2-181
 MulOU
 (Multiplication with Overflow Check) 2-185
 MULTIME (Multiply Time) 2-610
 Multiplexer 2-334
 Multiplication 2-181
 Multiplication with Overflow Check 2-185
 Multiply Time 2-610
 MUX (Multiplexer) 2-334

N

NanoSecToTime (Convert Nanoseconds to Time) 2-636
 Natural Exponential Operation 2-209
 Natural Logarithm 2-206
 N-bit Left Shift 2-396

N-bit Right Shift	2-396
NE (Not Equal)	2-94
NEascii (Text String Comparison Not Equal)	2-102
Neg (Reverse Sign)	2-405
NEXT (Repeat End)	2-82
NOT (Bit Reversal)	2-325
Not Equal	2-94
NSHLC (Shift N-bits Left with Carry)	2-398
NSHRC (Shift N-bits Right with Carry)	2-398
NumToDecString (Fixed-length Decimal Text String Conversion)	2-446
NumToEnum (Integer-to-Enumeration)	2-314
NumToHexString (Fixed-length Hexadecimal Text String Conversion)	2-446
NX_AryDOutTimeStamp (Write Digital Output Array with Specified Time Stamp)	2-1440
NX_ChangeWriteMode (Change to NX Unit Write Mode)	2-866
NX_DOutTimeStamp (Write Digital Output with Specified Time Stamp)	2-1434
NX_ModbusRtuCmd (Send Modbus RTU General Command)	2-1267
NX_ModbusRtuRead (Send Modbus RTU Read Command)	2-1277
NX_ModbusRtuWrite (Send Modbus RTU Write Command)	2-1288
NX_Read TotalPower OnTime (Read NX Unit Total Power ON Time)	2-877
NX_ReadObj (Read NX Unit Object)	2-987
NX_SaveParam (Save NX Unit Parameters)	2-871
NX_SerialBufClear (Clear Buffer)	2-1318
NX_SerialRcv (Receive No-protocol Data)	2-1253
NX_SerialSend (Send No-protocol Data)	2-1240
NX_SerialSigCtl (Serial Control Signal ON/OFF Switching)	2-1299
NX_SerialSigRead (Read Serial Control Signal)	2-1308
NX_SerialStartMon (Start Serial Line Monitoring) ..	2-1328
NX_SerialStatusRead (Read Serial Port Status)	2-1313
NX_SerialStopMon (Stop Serial Line Monitoring) ...	2-1333
NX_WriteObj (Write NX Unit Object)	2-972

O

Off-Delay Timer	2-132
On-Delay Timer	2-126
Open File	2-1348
OR	2-20
OR (Logical OR)	2-320
OR (OR)	2-20
OR NOT	2-20
ORN (OR NOT)	2-20
Out (Output)	2-22
OutABit (Output A Bit)	2-63
OutNot (Output NOT)	2-22
Output	2-22
Output A Bit	2-63
Output NOT	2-22

P

PackDword (4-byte Join)	2-489
PackWord (2-byte Join)	2-487
PID Control with Autotuning	2-666
PIDAT (PID Control with Autotuning)	2-666
PIDAT_HeatCool	2-691
PLC_ReadTotalPowerOnTime (Read PLC Total Power ON Time)	2-885
PrgStart (Enable Program)	2-890
PrgStatus (Read Program Status)	2-919
PrgStop (Disable Program)	2-899
Principal Arc Cosine	2-201
Principal Arc Sine	2-201
Principal Arc Tangent	2-201
Protocol Macro	2-1188
Push onto Stack	2-492
Put Text String	2-1383
Put Text Strings with Delimiters	2-571
PWLApprox (Broken Line Approximation with Broken Line Data Check)	2-426
PWLApproxNoLineChk (Broken Line Approximation without Broken Line Data Check)	2-426
PWLLineChk (Broken Line Data Check)	2-432

R

Radians to Degrees	2-196
RadToDeg (Radians to Degrees)	2-196
Rand (Random Number)	2-219
Random Number	2-219
Range Record Search	2-513
Read Current Task Period	2-1459
Read Current Task Status	2-1456
Read Data Trace Status	2-804
Read EtherCAT CoE SDO	2-929
Read File	2-1359
Read IO-Link Device Object	2-998
Read NTP Status	2-858
Read NX Unit Object	2-987
Read NX Unit Total Power ON Time	2-877
Read PLC Total Power ON Time	2-885
Read Program Status	2-919
Read Serial Control Signal	2-1308
Read Serial Port Status	2-1313
Read TCP Socket Status	2-1105
Read Variable Class 3 Explicit	2-1031
Read Variable from File	2-1343
Read Variable UCMM Explicit	2-1051
ReadNbit_** (N-bit Read Group)	2-1450
Real Number Check	2-237
Real Number Conversion Group	2-310
Real Number Fraction	2-235
Real Number Modulo-division	2-233
Real Number-to-Bit String Conversion Group	2-279
Real Number-to-Integer Conversion Group	2-276
Real Number-to-Real Number Conversion Group	2-281
Real Number-to-Text String Conversion Group	2-287

- RealToFormatString
 (REAL-to-Formatted Text String) 2-289
 REAL-to-Formatted Text String 2-289
 Receive No-protocol Data 2-1253
 RecMax (Maximum Record Search) 2-526
 RecMin (Minimum Record Search) 2-526
 RecNum (Get Number of Records) 2-524
 Record Search 2-508
 Record Sort 2-518
 RecRangeSearch (Range Record Search) 2-513
 RecSearch (Record Search) 2-508
 RecSort (Record Sort) 2-518
 Repeat 2-36
 REPEAT (Repeat) 2-36
 Repeat End 2-82
 Repeat Start 2-82
 REPLACE (Replace String) 2-557
 Replace String 2-557
 Reset 2-56
 Reset (Reset) 2-56
 Reset A Bit 2-61
 Reset Bits 2-59
 Reset EtherCAT Error 2-835
 Reset Motion Control Error 2-828
 Reset NX Bus Error 2-840
 Reset PLC Controller Error 2-817
 Reset User-defined Error 2-813
 ResetABit (Reset A Bit) 2-61
 ResetAlarm (Reset User-defined Error) 2-813
 ResetBits (Reset Bits) 2-59
 ResetCJBError (Reset I/O Bus Error) 2-822
 ResetECError (Reset EtherCAT Error) 2-835
 ResetMCError (Reset Motion Control Error) 2-828
 ResetNXBError (Reset NX Bus Error) 2-840
 ResetPLCError (Reset PLC Controller Error) 2-817
 Reset-Priority Keep 2-50
 ResetUnit (Restart Unit) 2-854
 Restart NX Units 2-860
 Restart Unit 2-854
 RestartNXUnit (Restart NX Units) 2-860
 Return 2-67
 RETURN (Return) 2-67
 Reverse Sign 2-405
 Reversible Shift Register 2-390
 RIGHT (Get String Right) 2-550
 ROL (Rotate N-bits Left) 2-400
 ROR (Rotate N-bits Right) 2-400
 Rotate N-bits Left 2-400
 Rotate N-bits Right 2-400
 Round (Round Off Real Number) 2-316
 Round Off Real Number 2-316
 Round Up Real Number 2-316
 RoundUp (Round Up Real Number) 2-316
 RS (Reset-Priority Keep) 2-50
 R_TRIG (Up Trigger) 2-44
- S**
-
- Save EtherCAT Packets 2-942
 Save NX Unit Parameters 2-871
 ScaleTrans (Scale Transformation) 2-769
 SCU Receive Serial 2-1212
 SCU Receive Serial without Receive Buffer Clear .. 2-1212
 SCU Send Serial 2-1201
 SD Memory Card Backup 2-1417
 SecToDate (Convert Seconds to Date) 2-630
 SecToDt (Convert Seconds to Date and Time) 2-628
 SecToTime (Convert Seconds to Time) 2-637
 SecToTod (Convert Seconds to Time of Day) 2-632
 Seek File 2-1355
 SEL (Binary Selection) 2-332
 Send Command 2-1227
 Send Explicit Message Class 3 2-1043
 Send Explicit Message UCMM 2-1063
 Send Modbus RTU General Command 2-1267
 Send Modbus RTU Read Command 2-1277
 Send Modbus RTU Write Command 2-1288
 Send No-protocol Data 2-1240
 SendCmd (Send Command) 2-1227
 Separate Mantissa and Exponent 2-441
 Serial Control Signal ON/OFF Switching 2-1299
 SerialRcv (SCU Receive Serial) 2-1212
 SerialRcvNoClear (SCU Receive Serial
 without Receive Buffer Clear) 2-1212
 SerialSend (SCU Send Serial) 2-1201
 Set 2-56
 Set (Set) 2-56
 Set A Bit 2-61
 Set Bits 2-59
 Set TCP Socket Option 2-1114
 Set Time 2-620
 SetABit (Set A Bit) 2-61
 SetAlarm (Create User-defined Error) 2-808
 SetBits (Set Bits) 2-59
 SetBlock (Block Set) 2-365
 SetInfo (Create User-defined Information) 2-852
 Set-Priority Keep 2-53
 SetTime (Set Time) 2-620
 Shift N-bits Left with Carry 2-398
 Shift N-bits Right with Carry 2-398
 Shift Register 2-388
 SHL (N-bit Left Shift) 2-396
 SHR (N-bit Right Shift) 2-396
 Signed BCD-to-Signed Integer Conversion 2-250
 Signed Integer-to-BCD Conversion Group 2-253
 SIN (Sine in Radians) 2-198
 Sine in Radians 2-198
 SizeOfAry (Get Number of Array Elements) 2-485
 SJIS to UTF-8 Character Code Conversion 2-424
 SJISToUTF8
 (SJIS to UTF-8 Character Code Conversion) 2-424
 SktClearBuf
 (Clear TCP/UDP Socket Receive Buffer) 2-1111
 SktClose (Close TCP/UDP Socket) 2-1108
 SktGetTCP Status (Read TCP Socket Status) 2-1105
 SktSetOption (Set TCP Socket Option) 2-1114
 SktTCP Connect (Connect TCP Socket) 2-1090
 SktTCPAccept (Accept TCP Socket) 2-1087

- SktTCPRecv (TCP Socket Receive) 2-1099
 SktTCPSend (TCP Socket Send) 2-1102
 SktUDP Create (Create UDP Socket) 2-1073
 SktUDPRecv (UDP Socket Receive) 2-1081
 SktUDPSend (UDP Socket Send) 2-1084
 SQRT (Square Root) 2-204
 Square Root 2-204
 SR (Set-Priority Keep) 2-53
 StackDel (Delete from Stack) 2-506
 StackFIFO (First In First Out) 2-501
 StackIns (Insert into Stack) 2-504
 StackLIFO (Last In First Out) 2-501
 StackPush (Push onto Stack) 2-492
 Start EtherCAT Packet Monitor 2-934
 Start Serial Line Monitoring 2-1328
 Stop EtherCAT Packet Monitor 2-940
 Stop Serial Line Monitoring 2-1333
 String Length 2-556
 StringCRC16 (Calculate Text String CRC-16) 2-538
 StringCRCCITT
 (Calculate Text String CRC-CCITT) 2-536
 StringLRC (Calculate Text String LRC) 2-534
 StringSum (Checksum Calculation) 2-532
 STRING_TO_**
 (Text String-to-Bit String Conversion Group) 2-301
 STRING_TO_**
 (Text String-to-Integer Conversion Group) 2-299
 STRING_TO_**
 (Text String-to-Real Number Conversion Group) ... 2-303
 StringToAry (Text String-to-Array Conversion) 2-463
 StringToFixNum
 (Text String-to-Fixed-decimal Conversion) 2-453
 SUB (Subtraction) 2-174
 SUB_DATE_DATE (Subtract Date) 2-605
 SubDelimiter (Get Text Strings Minus Delimiters) 2-582
 SUB_DT_DT (Subtract Date and Time) 2-606
 SUB_DT_TIME (Subtract Time from Date and Time) 2-608
 SubOU
 (Subtraction with Overflow Check) 2-177
 SUB_TIME (Subtract Time) 2-600
 SUB_TOD_TIME (Subtract Time from Time of Day) 2-602
 SUB_TOD_TOD (Subtract Time of Day) 2-604
 Subtract Date 2-605
 Subtract Date and Time 2-606
 Subtract Time 2-600
 Subtract Time from Date and Time 2-608
 Subtract Time from Time of Day 2-602
 Subtract Time of Day 2-604
 Subtraction 2-174
 Subtraction with Overflow Check 2-177
 Swap (Swap Bytes) 2-404
 Swap Bytes 2-404
- ## T
-
- Table Comparison 2-111
 TableCmp (Table Comparison) 2-111
 TAN (Tangent in Radians) 2-198
 Tangent in Radians 2-198
- Task_IsActive (Determine Task Status) 2-1462
 TCP Socket Receive 2-1099
 TCP Socket Send 2-1102
 Test A Bit 2-47
 Test A Bit NOT 2-47
 TestABit (Test A Bit) 2-47
 TestABitN (Test A Bit NOT) 2-47
 Text String Comparison Equal 2-100
 Text String Comparison Greater Than 2-104
 Text String Comparison Greater Than or Equal 2-104
 Text String Comparison Less Than 2-104
 Text String Comparison Less Than or Equal 2-104
 Text String Comparison Not Equal 2-102
 Text String-to-Array Conversion 2-463
 Text String-to-Bit String Conversion Group 2-301
 Text String-to-Fixed-decimal Conversion 2-453
 Text String-to-Integer Conversion Group 2-299
 Text String-to-Real Number Conversion Group 2-303
 Time of Day-to-Text String Conversion 2-459
 Time-proportional Output 2-729
 TimeProportionalOut (Time-proportional Output) 2-729
 Timer (Hundred-ms Timer) 2-141
 Timer Pulse 2-135
 TimeToNanoSec (Convert Time to Nanoseconds) ... 2-634
 TimeToSec (Convert Time to Seconds) 2-635
 TO_** (Bit String Conversion Group) 2-308
 TO_** (Integer Conversion Group) 2-306
 TO_** (Real Number Conversion Group) 2-310
 ToAryByte (Conversion to Byte Array) 2-475
 TodToSec (Convert Time of Day to Seconds) 2-627
 TodToString
 (Time of Day-to-Text String Conversion) 2-459
 TOF (Off-Delay Timer) 2-132
 ToLCase (Convert to Lowercase) 2-567
 TON (On-Delay Timer) 2-126
 ToUCase (Convert to Uppercase) 2-567
 TP (Timer Pulse) 2-135
 TraceSamp (Data Trace Sampling) 2-798
 TraceTrig (Data Trace Trigger) 2-801
 TransBits (Move Bits) 2-361
 Transfer EtherCAT Packets 2-944
 Trim String Left 2-569
 Trim String Right 2-569
 TrimL (Trim String Left) 2-569
 TrimR (Trim String Right) 2-569
 TRUNC (Truncate) 2-316
 Truncate 2-316
 Truncate Date and Time 2-656
 Truncate Time 2-652
 Truncate Time of Day 2-660
 TruncDt (Truncate Date and Time) 2-656
 TruncTime (Truncate Time) 2-652
 TruncTod (Truncate Time of Day) 2-660
- ## U
-
- UDP Socket Receive 2-1081
 UDP Socket Send 2-1084
 Unite8Bit_** (Byte Data Join Group) 2-473

UniteDigit_** (Four-bit Join Group)	2-469
UniteReal (Combine Real Number Mantissa and Exponent) ..	2-444
Unlock (Unlock Tasks)	2-1464
Unlock Tasks	2-1464
Unsigned Integer-to-BCD Conversion Group	2-245
Up (Up Trigger)	2-44
Up Trigger	2-44
Up-counter	2-150
Up-counter Group	2-152
Up-down Counter	2-155
Up-down Counter Group	2-159
Upper/Lower Deviation Alarm Group	2-749
Upper/Lower Deviation Alarm with Standby Sequence Group	2-754
Upper/Lower Limit Alarm Group	2-745
UTF-8 to SJIS Character Code Conversion	2-422
UTF8ToSJIS (UTF-8 to SJIS Character Code Conversion)	2-422

W

While	2-34
WHILE (While)	2-34
Write EtherCAT CoE SDO	2-926
Write File	2-1367
Write IO-Link Device Object	2-1007
Write NX Unit Object	2-972
Write Variable Class 3 Explicit	2-1037
Write Variable to File	2-1338
Write Variable UCMM Explicit	2-1056
WriteNbit_** (N-bit Write Group)	2-1452

X

XOR (Logical Exclusive OR)	2-320
XORN (Logical Exclusive NOR)	2-323

Z

Zone (Dead Zone Control)	2-342
Zone Comparison	2-109
ZoneCmp (Zone Comparison)	2-109

OMRON Corporation Industrial Automation Company
Kyoto, JAPAN

Contact: www.ia.omron.com

Regional Headquarters

OMRON EUROPE B.V.

Wegalaan 67-69, 2132 JD Hoofddorp
The Netherlands
Tel: (31)2356-81-300/Fax: (31)2356-81-388

OMRON ELECTRONICS LLC

2895 Greenspoint Parkway, Suite 200
Hoffman Estates, IL 60169 U.S.A.
Tel: (1) 847-843-7900/Fax: (1) 847-843-7787

OMRON ASIA PACIFIC PTE. LTD.

No. 438A Alexandra Road # 05-05/08 (Lobby 2),
Alexandra Technopark,
Singapore 119967
Tel: (65) 6835-3011/Fax: (65) 6835-2711

OMRON (CHINA) CO., LTD.

Room 2211, Bank of China Tower,
200 Yin Cheng Zhong Road,
PuDong New Area, Shanghai, 200120, China
Tel: (86) 21-5037-2222/Fax: (86) 21-5037-2200

Authorized Distributor:

© OMRON Corporation 2011-2017 All Rights Reserved.
In the interest of product improvement,
specifications are subject to change without notice.

Cat. No. W502-E1-21

1017