

Machine Automation Controller NJ/NX-series

Troubleshooting Manual

NX701-17□□

NX701-16□□

NX1P2-11□□□□

NX1P2-10□□□□

NX1P2-90□□□□

NJ501-□5□□

NJ501-□4□□

NJ501-□3□□

NJ301-12□□

NJ301-11□□

NJ101-10□□

NJ101-90□□

NOTE

All rights reserved. No part of this publication may be reproduced, stored in a retrieval system, or transmitted, in any form, or by any means, mechanical, electronic, photocopying, recording, or otherwise, without the prior written permission of OMRON.

No patent liability is assumed with respect to the use of the information contained herein. Moreover, because OMRON is constantly striving to improve its high-quality products, the information contained in this manual is subject to change without notice. Every precaution has been taken in the preparation of this manual. Nevertheless, OMRON assumes no responsibility for errors or omissions. Neither is any liability assumed for damages resulting from the use of the information contained in this publication.

Trademarks

- Sysmac and SYSMAC are trademarks or registered trademarks of OMRON Corporation in Japan and other countries for OMRON factory automation products.
- Microsoft, Windows, Windows Vista, Excel, and Visual Basic are either registered trademarks or trademarks of Microsoft Corporation in the United States and other countries.
- EtherCAT® is registered trademark and patented technology, licensed by Beckhoff Automation GmbH, Germany.
- ODVA, CIP, CompoNet, DeviceNet, and EtherNet/IP are trademarks of ODVA.
- The SD and SDHC logos are trademarks of SD-3C, LLC. 

Other company names and product names in this document are the trademarks or registered trademarks of their respective companies.

Copyrights

Microsoft product screen shots reprinted with permission from Microsoft Corporation.

Introduction

Thank you for purchasing an NJ/NX-series CPU Unit.

This manual contains information that is necessary to use the NJ/NX-series CPU Unit. Please read this manual and make sure you understand the functionality and performance of the NJ/NX-series CPU Unit before you attempt to use it in a control system.

Keep this manual in a safe place where it will be available for reference during operation.

Intended Audience

This manual is intended for the following personnel, who must also have knowledge of electrical systems (an electrical engineer or the equivalent).

- Personnel in charge of introducing FA systems.
- Personnel in charge of designing FA systems.
- Personnel in charge of installing and maintaining FA systems.
- Personnel in charge of managing FA systems and facilities.

For programming, this manual is intended for personnel who understand the programming language specifications in international standard IEC 61131-3 or Japanese standard JIS B 3503.

Applicable Products

This manual covers the following products.

- NX-series CPU Units
 - NX701-17□□
 - NX701-16□□
 - NX1P2-11□□□□
 - NX1P2-11□□□□1
 - NX1P2-10□□□□
 - NX1P2-10□□□□1
 - NX1P2-90□□□□
 - NX1P2-90□□□□1
- NJ-series CPU Units
 - NJ501-□5□□
 - NJ501-□4□□
 - NJ501-□3□□
 - NJ301-12□□
 - NJ301-11□□
 - NJ101-10□□
 - NJ101-90□□

Part of the specifications and restrictions for the CPU Units are given in other manuals. Refer to *Relevant Manuals* on page 2 and *Related Manuals* on page 21.

Relevant Manuals

The following table provides the relevant manuals for the NJ/NX-series CPU Units. Read all of the manuals that are relevant to your system configuration and application before you use the NJ/NX-series CPU Unit.

Most operations are performed from the Sysmac Studio Automation Software. Refer to the *Sysmac Studio Version 1 Operation Manual* (Cat. No. W504) for information on the Sysmac Studio.

Purpose of use	Manual														
	Basic information				NJ/NX-series Motion Control User's Manual	NJ/NX-series Motion Control Instructions Reference Manual	NJ/NX-series CPU Unit	NJ/NX-series CPU Unit Built-in EtherCAT Port User's Manual	NJ/NX-series CPU Unit Built-in EtherNet/IP Port User's Manual	NJ/NX-series CPU Unit OPC UA User's Manual	NJ/NX-series Database Connection CPU Units User's Manual	NJ-series SECS/GEM CPU Units User's Manual	NJ-series NJ Robotics CPU Unit User's Manual	NJ/NY-series NC Integrated Controller User's Manual	NJ/NX-series Troubleshooting Manual
	NJ-series CPU Unit Hardware User's Manual	NX-series NX1P2 CPU Unit Hardware User's Manual	NX-series CPU Unit Hardware User's Manual	NJ/NX-series Software User's Manual											
Introduction to NX701 CPU Units	●														
Introduction to NX1P2 CPU Units		●													
Introduction to NJ-series Controllers			●												
Setting devices and hardware	●	●	●												
Using motion control					●										
Using EtherCAT						●									
Using EtherNet/IP							●								
Software settings				●											
Using motion control					●										
Using EtherCAT						●									
Using EtherNet/IP							●								
Using OPC UA								●							
Using the database connection service									●						
Using the GEM Services										●					
Using robot control											●				
Using numerical control												●			
Using the NX1P2 CPU Unit functions				●										●	
Writing the user program				●	●										
Using motion control					●	●									
Using EtherCAT							●								
Using EtherNet/IP								●							
Using OPC UA									●						
Using the database connection service										●					
Using the GEM Services											●				
Using robot control												●			
Using numerical control													●		
Programming error processing														●	
Using the NX1P2 CPU Unit functions				●											●

Purpose of use	Manual														
	Basic information														
	NJ-series CPU Unit Hardware User's Manual	NX-series NX1P2 CPU Unit Hardware User's Manual	NX-series CPU Unit Software User's Manual	NJ/NX-series Built-in I/O and Option Board User's Manual	NJ/NX-series Instructions Reference Manual	NJ/NX-series Motion Control User's Manual	NJ/NX-series Motion Control Instructions Reference Manual	NJ/NX-series Built-in EtherCAT Port User's Manual	NJ/NX-series CPU Unit Built-in EtherNet/IP Port User's Manual	NJ-series CPU Unit OPC UA User's Manual	NJ/NX-series Database Connection CPU Units User's Manual	NJ-series SECS/GEM CPU Units User's Manual	NJ-series NJ Robotics CPU Unit User's Manual	NJ/NY-series NC Integrated Controller User's Manual	NJ/NX-series Troubleshooting Manual
Testing operation and debugging			●												
Using motion control						●									
Using EtherCAT							●								
Using EtherNet/IP								●							
Using OPC UA									●						
Using the database connection service										●					
Using the GEM Services											●				
Using robot control												●			
Using numerical control													●		
Using the NX1P2 CPU Unit functions			●												
Learning about error management and corrections *1	▲	▲	▲	▲	▲	▲		▲	▲	▲	▲	▲			●
Maintenance															
Using motion control															
Using EtherCAT	●	●	●					●							
Using EtherNet/IP									●						

*1 Refer to the *NJ/NX-series Troubleshooting Manual* (Cat. No. W503) for the error management concepts and an overview of the error items. Refer to the manuals that are indicated with triangles for details on errors for the corresponding Units.

Manual Structure

Page Structure

The following page structure is used in this manual.

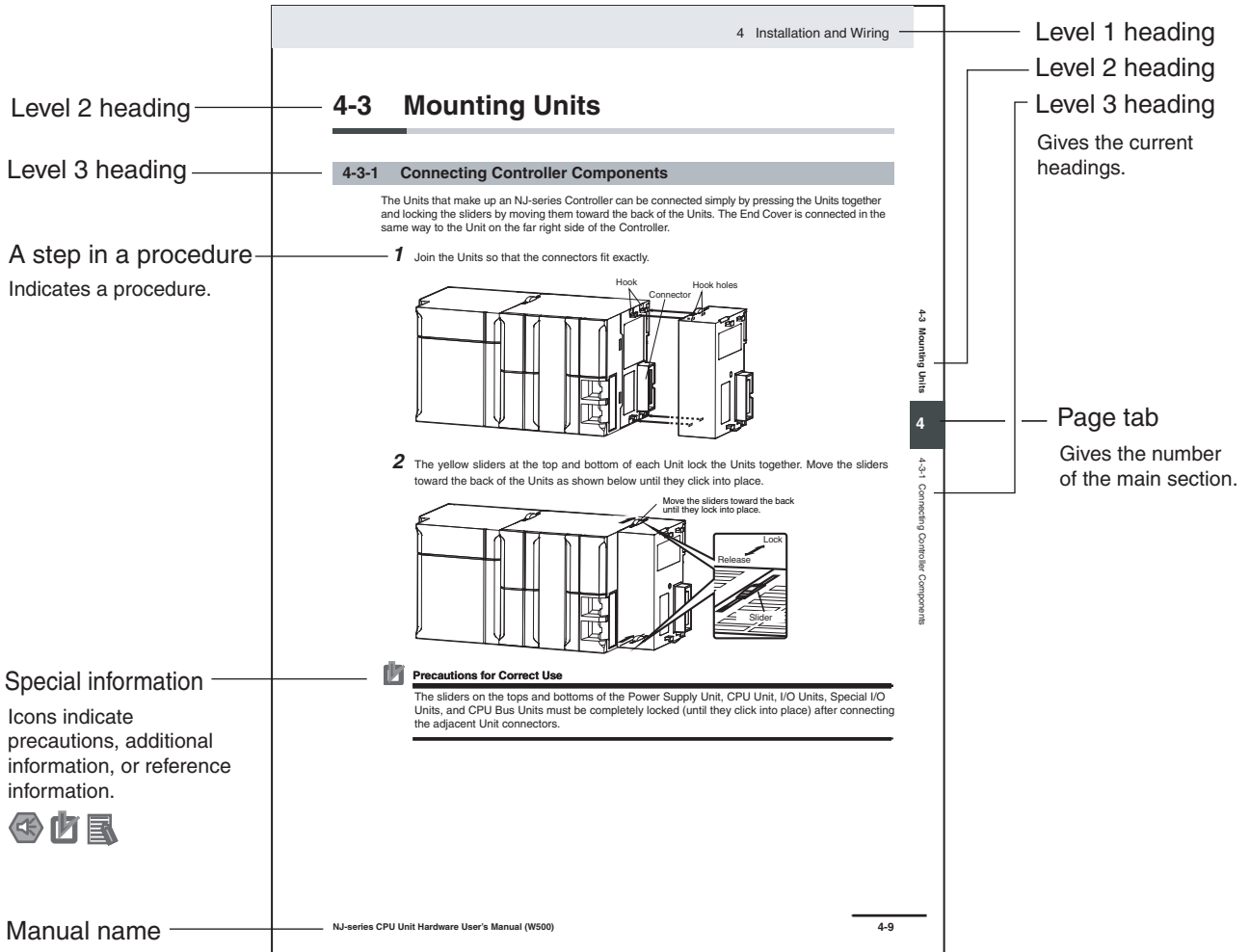

This illustration is provided only as a sample. It may not literally appear in this manual.

Special Information

Special information in this manual is classified as follows:



Precautions for Safe Use

Precautions on what to do and what not to do to ensure safe usage of the product.



Precautions for Correct Use

Precautions on what to do and what not to do to ensure proper operation and performance.



Additional Information

Additional information to read as required.

This information is provided to increase understanding or make operation easier.

Note References are provided to more detailed or related information.

Precaution on Terminology

In this manual, “download” refers to transferring data from the Sysmac Studio to the physical Controller and “upload” refers to transferring data from the physical Controller to the Sysmac Studio.

For the Sysmac Studio, synchronization is used to both upload and download data. Here, “synchronize” means to automatically compare the data for the Sysmac Studio on the computer with the data in the physical Controller and transfer the data in the direction that is specified by the user.

Sections in this Manual

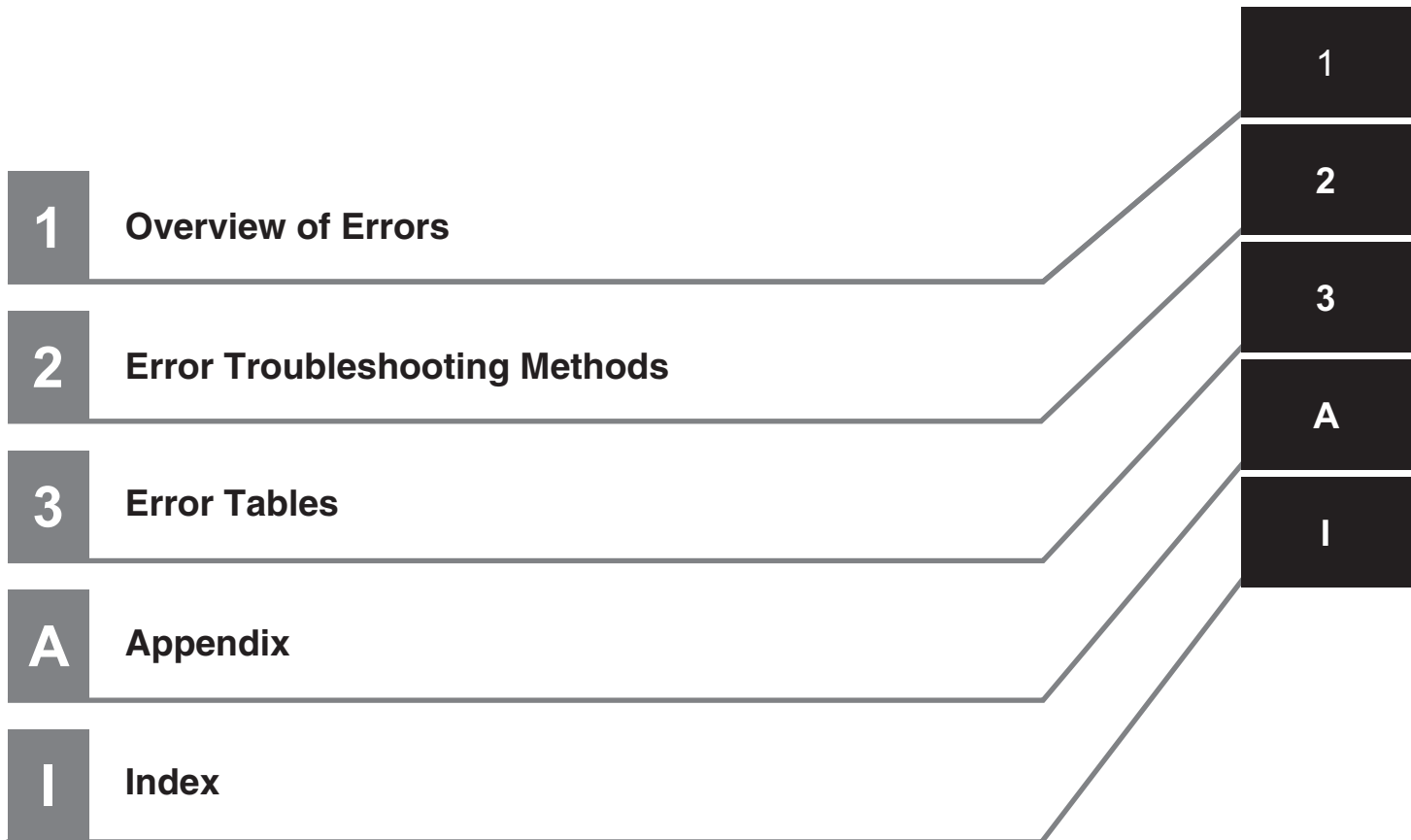

CONTENTS

Introduction	1
Relevant Manuals	2
Manual Structure	4
Sections in this Manual	7
Terms and Conditions Agreement.....	10
Safety Precautions	12
Precautions for Safe Use.....	13
Precautions for Correct Use.....	14
Regulations and Standards	15
Versions	17
Related Manuals	21
Revision History	25

Section 1 Overview of Errors

1-1 Overview of NJ/NX-series Errors	1-2
1-1-1 Types of Errors.....	1-3
1-1-2 CPU Unit Status	1-4
1-2 Fatal Errors.....	1-7
1-2-1 Types of Fatal Errors.....	1-7
1-2-2 Checking for Fatal Errors	1-8
1-3 Non-fatal Errors	1-9
1-3-1 Types of Non-fatal Errors	1-9
1-3-2 Checking for Non-fatal Errors.....	1-19
1-3-3 Resetting Non-fatal Errors.....	1-22

Section 2 Error Troubleshooting Methods

2-1 Troubleshooting Flowcharts.....	2-2
2-1-1 Checking to See If the CPU Unit Is Operating	2-2
2-1-2 Troubleshooting Flowchart for Non-fatal Errors	2-4
2-2 Troubleshooting Fatal Errors	2-5
2-3 Troubleshooting Non-fatal Errors	2-7
2-3-1 Identifying and Resetting Errors with the Sysmac Studio.....	2-7
2-3-2 Identifying and Resetting Errors with an HMI.....	2-11
2-3-3 Identifying and Resetting Errors from the User Program	2-14
2-3-4 Checking for Errors with System-defined Variables	2-16
2-4 Troubleshooting When You Cannot Go Online from the Sysmac Studio	2-18
2-4-1 Causes and Correction When You Cannot Go Online from the Sysmac Studio	2-18
2-4-2 Troubleshooting for Each Cause.....	2-20

Section 3 Error Tables

3-1	Errors by Source	3-2
3-1-1	Interpreting Error Descriptions	3-2
3-1-2	Errors in the PLC Function Module	3-2
3-1-3	Errors in the NX Bus Function Module	3-61
3-1-4	Errors in the Motion Control Function Module	3-64
3-1-5	Errors in the EtherNet/IP Function Module	3-95
3-1-6	Errors in the EtherCAT Master Function Module	3-99
3-1-7	Errors in OPC UA	3-104
3-1-8	Errors in the DB Connection Service Function	3-108
3-1-9	Errors in GEM Services	3-114
3-1-10	Errors in Robot Control Function	3-119
3-1-11	Errors in CNC Function	3-134
3-1-12	Errors in Slave Terminals	3-150
3-1-13	Errors in EtherCAT Slaves	3-190
3-1-14	Errors in CJ-series Units	3-223
3-2	An Error Log Table for CJ-series Special Units	3-243
3-3	Events in Order of Event Codes	3-248
3-3-1	Interpreting Error Descriptions	3-248
3-3-2	Error Table	3-249
3-4	Instruction Error Table	3-296

Appendix

A-1	Applicable Range of the HMI Troubleshooter	A-2
A-1-1	Combinations of HMIs and CPU Units That Enable Using the Troubleshooter	A-2
A-1-2	System Configuration Elements Supported by the Troubleshooter	A-3
A-2	Correspondence of NX Bus Events between NX1P2 CPU Units and Slave Terminals	A-4

Index

Terms and Conditions Agreement

Warranty, Limitations of Liability

Warranties

● Exclusive Warranty

Omron's exclusive warranty is that the Products will be free from defects in materials and workmanship for a period of twelve months from the date of sale by Omron (or such other period expressed in writing by Omron). Omron disclaims all other warranties, express or implied.

● Limitations

OMRON MAKES NO WARRANTY OR REPRESENTATION, EXPRESS OR IMPLIED, ABOUT NON-INFRINGEMENT, MERCHANTABILITY OR FITNESS FOR A PARTICULAR PURPOSE OF THE PRODUCTS. BUYER ACKNOWLEDGES THAT IT ALONE HAS DETERMINED THAT THE PRODUCTS WILL SUITABLY MEET THE REQUIREMENTS OF THEIR INTENDED USE.

Omron further disclaims all warranties and responsibility of any type for claims or expenses based on infringement by the Products or otherwise of any intellectual property right.

● Buyer Remedy

Omron's sole obligation hereunder shall be, at Omron's election, to (i) replace (in the form originally shipped with Buyer responsible for labor charges for removal or replacement thereof) the non-complying Product, (ii) repair the non-complying Product, or (iii) repay or credit Buyer an amount equal to the purchase price of the non-complying Product; provided that in no event shall Omron be responsible for warranty, repair, indemnity or any other claims or expenses regarding the Products unless Omron's analysis confirms that the Products were properly handled, stored, installed and maintained and not subject to contamination, abuse, misuse or inappropriate modification. Return of any Products by Buyer must be approved in writing by Omron before shipment. Omron Companies shall not be liable for the suitability or unsuitability or the results from the use of Products in combination with any electrical or electronic components, circuits, system assemblies or any other materials or substances or environments. Any advice, recommendations or information given orally or in writing, are not to be construed as an amendment or addition to the above warranty.

See <http://www.omron.com/global/> or contact your Omron representative for published information.

Limitation on Liability; Etc

OMRON COMPANIES SHALL NOT BE LIABLE FOR SPECIAL, INDIRECT, INCIDENTAL, OR CONSEQUENTIAL DAMAGES, LOSS OF PROFITS OR PRODUCTION OR COMMERCIAL LOSS IN ANY WAY CONNECTED WITH THE PRODUCTS, WHETHER SUCH CLAIM IS BASED IN CONTRACT, WARRANTY, NEGLIGENCE OR STRICT LIABILITY.

Further, in no event shall liability of Omron Companies exceed the individual price of the Product on which liability is asserted.

Application Considerations

Suitability of Use

Omron Companies shall not be responsible for conformity with any standards, codes or regulations which apply to the combination of the Product in the Buyer's application or use of the Product. At Buyer's request, Omron will provide applicable third party certification documents identifying ratings and limitations of use which apply to the Product. This information by itself is not sufficient for a complete determination of the suitability of the Product in combination with the end product, machine, system, or other application or use. Buyer shall be solely responsible for determining appropriateness of the particular Product with respect to Buyer's application, product or system. Buyer shall take application responsibility in all cases.

NEVER USE THE PRODUCT FOR AN APPLICATION INVOLVING SERIOUS RISK TO LIFE OR PROPERTY WITHOUT ENSURING THAT THE SYSTEM AS A WHOLE HAS BEEN DESIGNED TO ADDRESS THE RISKS, AND THAT THE OMRON PRODUCT(S) IS PROPERLY RATED AND INSTALLED FOR THE INTENDED USE WITHIN THE OVERALL EQUIPMENT OR SYSTEM.

Programmable Products

Omron Companies shall not be responsible for the user's programming of a programmable Product, or any consequence thereof.

Disclaimers

Performance Data

Data presented in Omron Company websites, catalogs and other materials is provided as a guide for the user in determining suitability and does not constitute a warranty. It may represent the result of Omron's test conditions, and the user must correlate it to actual application requirements. Actual performance is subject to the Omron's Warranty and Limitations of Liability.

Change in Specifications

Product specifications and accessories may be changed at any time based on improvements and other reasons. It is our practice to change part numbers when published ratings or features are changed, or when significant construction changes are made. However, some specifications of the Product may be changed without any notice. When in doubt, special part numbers may be assigned to fix or establish key specifications for your application. Please consult with your Omron's representative at any time to confirm actual specifications of purchased Product.

Errors and Omissions

Information presented by Omron Companies has been checked and is believed to be accurate; however, no responsibility is assumed for clerical, typographical or proofreading errors or omissions.

Safety Precautions

Refer to the following manuals for safety precautions.

- NX-series CPU Unit Hardware User's Manual (Cat. No. W535)
- NX-series NX1P2 CPU Unit Hardware User's Manual (Cat. No. W578)
- NJ-series CPU Unit Hardware User's Manual (Cat No. W500)

Precautions for Safe Use

Refer to the following manuals for precautions for the safe use of the NJ/NX-series Controller. Installation precautions are also provided for the NJ/NX-series CPU Unit and the NJ/NX-series Controller system.

- NX-series CPU Unit Hardware User's Manual (Cat. No. W535)
- NX-series NX1P2 CPU Unit Hardware User's Manual (Cat. No. W578)
- NJ-series CPU Unit Hardware User's Manual (W500)

Precautions for Correct Use

Refer to the following manuals for precautions for the correct use of the NJ/NX-series Controller. Installation precautions are also provided for the NJ/NX-series CPU Unit and the NJ/NX-series Controller system.

- NX-series CPU Unit Hardware User's Manual (Cat. No. W535)
- NX-series NX1P2 CPU Unit Hardware User's Manual (Cat. No. W578)
- NJ-series CPU Unit Hardware User's Manual (W500)

Regulations and Standards

Conformance to EU Directives

Applicable Directives

- EMC Directives
- Low Voltage Directive

Concepts

● EMC Directive

OMRON devices that comply with EU Directives also conform to the related EMC standards so that they can be more easily built into other devices or the overall machine. The actual products have been checked for conformity to EMC standards.*

Whether the products conform to the standards in the system used by the customer, however, must be checked by the customer. EMC-related performance of the OMRON devices that comply with EU Directives will vary depending on the configuration, wiring, and other conditions of the equipment or control panel on which the OMRON devices are installed. The customer must, therefore, perform the final check to confirm that devices and the overall machine conform to EMC standards.

* Applicable EMC (Electromagnetic Compatibility) standards are as follows:

EMS (Electromagnetic Susceptibility): EN 61131-2

EMI (Electromagnetic Interference): EN 61131-2 (Radiated emission: 10-m regulations)

● Low Voltage Directive

Always ensure that devices operating at voltages of 50 to 1,000 VAC and 75 to 1,500 VDC meet the required safety standards. The applicable directive is EN 61010-2-201.

● Conformance to EU Directives

The NJ/NX-series Controllers comply with EU Directives. To ensure that the machine or device in which the NJ/NX-series Controller is used complies with EU Directives, the Controller must be installed as follows:

- The NJ/NX-series Controller must be installed within a control panel.
- You must use the power supply in SELV specifications for the DC power supplies connected to DC Power Supply Units and I/O Units.
- NJ/NX-series Controllers that comply with EU Directives also conform to the Common Emission Standard (EN 61000-6-4). Radiated emission characteristics (10-m regulations) may vary depending on the configuration of the control panel used, other devices connected to the control panel, wiring, and other conditions.

You must therefore confirm that the overall machine or equipment complies with EU Directives.

Conformance to KC Standards

Observe the following precaution if you use NX-series Units in Korea.

A 급 기기 (업무용방송통신기자재)

이 기기는 업무용(A 급) 전저파작합기기로서 판매자 또는 사용자는 이 점을 주의하시기 바라며, 가정외의 지역에서 사용하는 것을 목적으로 합니다.

Class A Device (Broadcasting Communications Device for Office Use)

This device obtained EMC registration for office use (Class A), and it is intended to be used in places other than homes.

Sellers and/or users need to take note of this.

Conformance to Shipbuilding Standards

The NJ/NX-series Controllers comply with the following shipbuilding standards. Applicability to the shipbuilding standards is based on certain usage conditions. It may not be possible to use the product in some locations. Contact your OMRON representative before attempting to use a Controller on a ship.

Usage Conditions for NK and LR Shipbuilding Standards

- The NJ/NX-series Controller must be installed within a control panel.
- Gaps in the door to the control panel must be completely filled or covered with gaskets or other material.
- The following noise filter must be connected to the power supply line.

Noise Filter

Manufacturer	Model
Cosel Co., Ltd.	TAH-06-683

Software Licenses and Copyrights

This product incorporates certain third party software. The license and copyright information associated with this software is available at http://www.fa.omron.co.jp/nj_info_e/.

Versions

Hardware revisions and unit versions are used to manage the hardware and software in NJ/NX-series Units and EtherCAT slaves. The hardware revision or unit version is updated each time there is a change in hardware or software specifications. Even when two Units or EtherCAT slaves have the same model number, they will have functional or performance differences if they have different hardware revisions or unit versions.

Checking Versions

You can check versions on the ID information indications or with the Sysmac Studio.

Checking Unit Versions on ID Information Indications

The unit version is given on the ID information indication on the side of the product.

The ID information on an NX-series NX701-□□□□ CPU Unit is shown below.

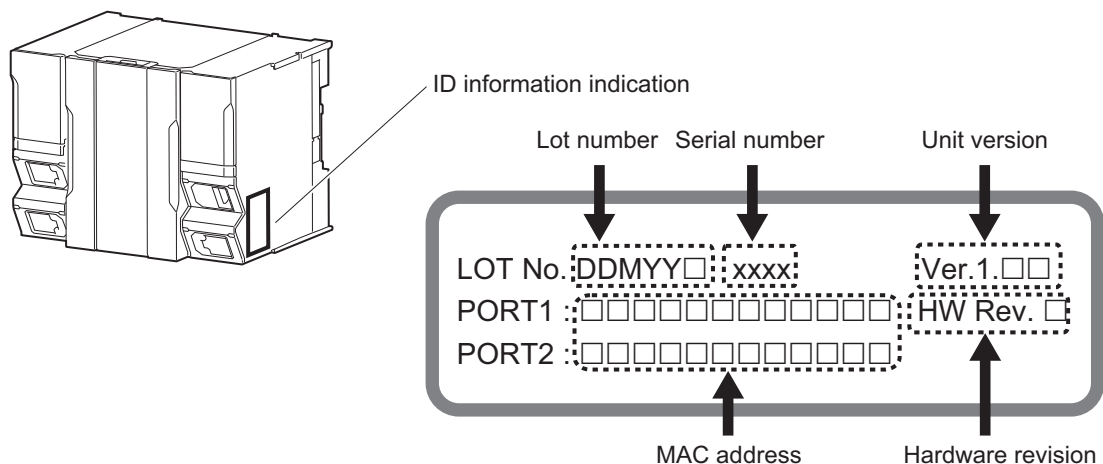

Note The hardware revision is not displayed for the Unit that the hardware revision is in blank.

The ID information on an NX-series NX1P2-□□□□□□ CPU Unit is shown below.

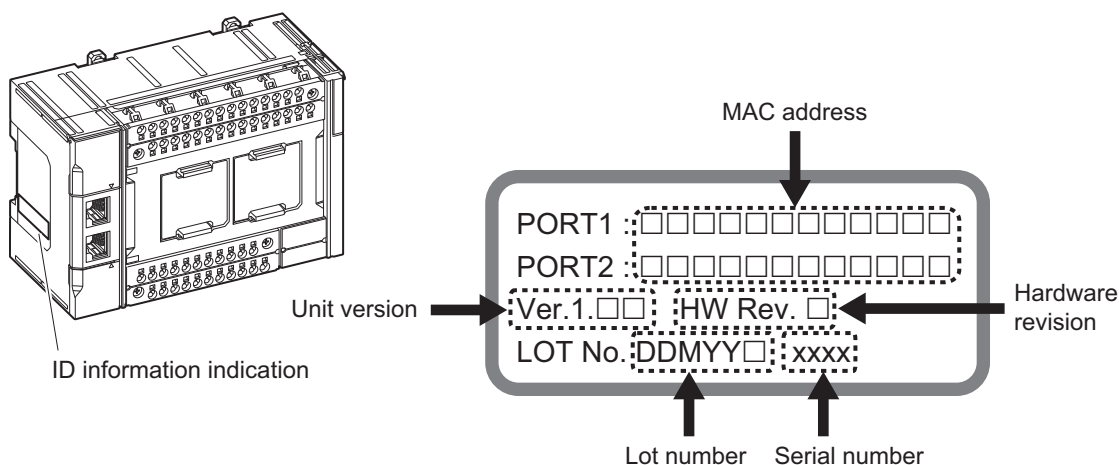

Note The hardware revision is not displayed for the Unit that the hardware revision is in blank.

The ID information on an NJ-series NJ501-□□□□ CPU Unit is shown below.

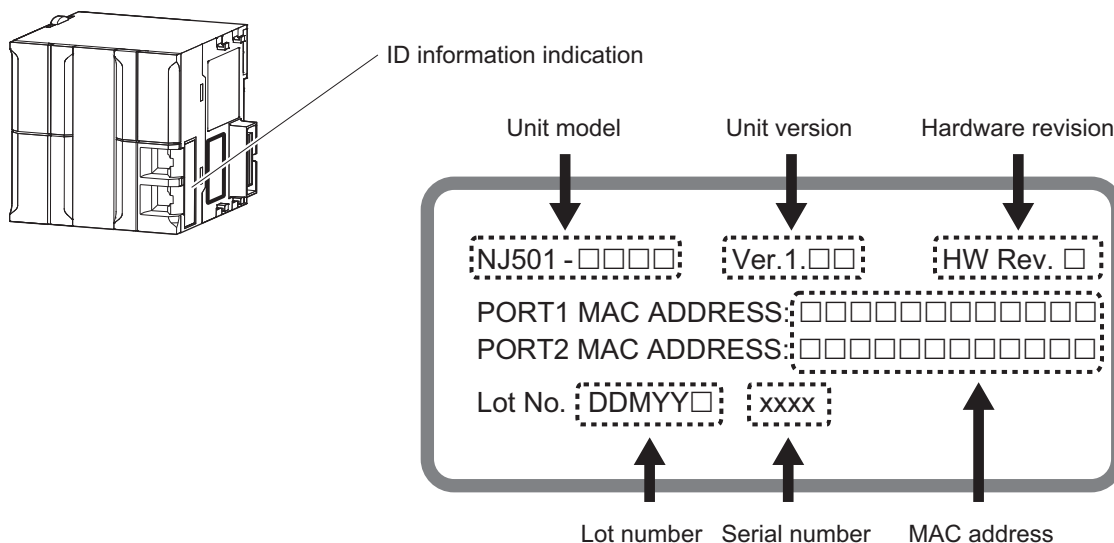

Note The hardware revision is not displayed for the Unit that the hardware revision is in blank.

Checking Unit Versions with the Sysmac Studio

You can use the Sysmac Studio to check unit versions. The procedure is different for Units and for EtherCAT slaves.

● Checking the Unit Version of an NX-series CPU Unit

You can use the Production Information while the Sysmac Studio is online to check the unit version of a Unit. You can do this for the CPU Unit. For an NX1P2 CPU Unit, you can also check the unit versions of the NX Units on the CPU Rack and Option Boards.

- 1 Right-click **CPU Rack** under **Configurations and Setup – CPU/Expansion Racks** in the Multiview Explorer and select **Production Information**.

The Production Information Dialog Box is displayed.

● Checking the Unit Version of an NJ-series CPU Unit

You can use the Production Information while the Sysmac Studio is online to check the unit version of a Unit. You can do this for the CPU Unit, CJ-series Special I/O Units, and CJ-series CPU Bus Units. You cannot check the unit versions of CJ-series Basic I/O Units with the Sysmac Studio.

Use the following procedure to check the unit version.

- 1 Double-click **CPU/Expansion Racks** under **Configurations and Setup** in the Multiview Explorer. Or, right-click **CPU/Expansion Racks** under **Configurations and Setup** and select **Edit** from the menu.

The Unit Editor is displayed.

- 2 Right-click any open space in the Unit Editor and select **Production Information**.

The Production Information Dialog Box is displayed.

● Changing Information Displayed in Production Information Dialog Box

- 1 Click the **Show Detail** or **Show Outline** Button at the lower right of the Production Information Dialog Box.

The view will change between the production information details and outline.

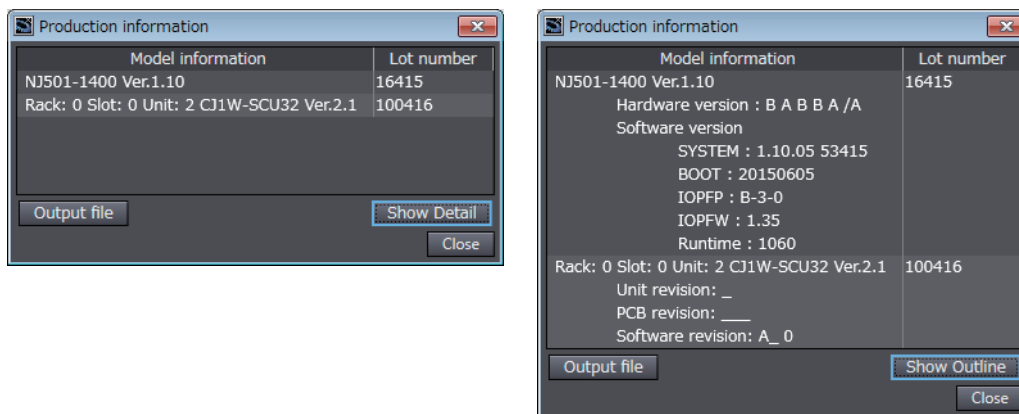

Outline View

Detail View

The information that is displayed is different for the Outline View and Detail View. The Detail View displays the unit version, hardware version, and software versions. The Outline View displays only the unit version.

Note The hardware revision is separated by “/” and displayed on the right of the hardware version. The hardware revision is not displayed for the Unit that the hardware revision is in blank.

● Checking the Unit Version of an EtherCAT Slave

You can use the Production Information while the Sysmac Studio is online to check the unit version of an EtherCAT slave. Use the following procedure to check the unit version.

- 1 Double-click **EtherCAT** under **Configurations and Setup** in the Multiview Explorer. Or, right-click **EtherCAT** under **Configurations and Setup** and select **Edit** from the menu.

The EtherCAT Tab Page is displayed.

- 2 Right-click the master on the EtherCAT Tab Page and select **Display Production Information**.

The Production Information Dialog Box is displayed.

The unit version is displayed after “Rev.”

● **Changing Information Displayed in Production Information Dialog Box**

- 1 Click the **Show Detail** or **Show Outline** Button at the lower right of the Production Information Dialog Box.

The view will change between the production information details and outline.

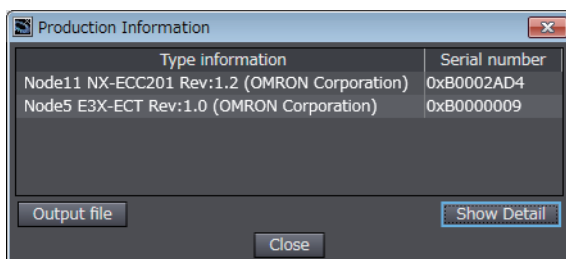

Outline View

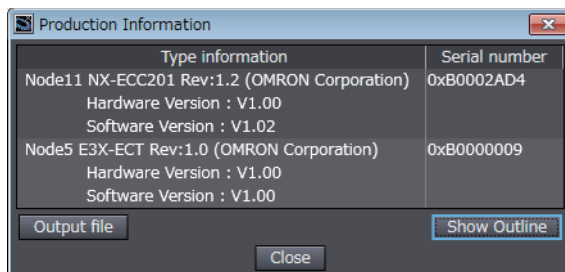

Detail View

Unit Versions of CPU Units and Sysmac Studio Versions

The events that can occur depend on the unit versions of the NJ/NX-series CPU Unit, the EtherCAT slaves, and the NX Units. You must use the corresponding version of Sysmac Studio to display events that were added for version upgrades when troubleshooting from the Sysmac Studio or from the Troubleshooter on an HMI. Refer to the product manuals for information on the unit versions of the CPU Unit, EtherCAT slaves, and NX Units, and for the relationship with the version of the Sysmac Studio.

Related Manuals

The followings are the manuals related to this manual. Use these manuals for reference.

Manual name	Cat. No.	Model numbers	Application	Description
NX-series CPU Unit Hardware User's Manual	W535	NX701-□□□□	Learning the basic specifications of the NX701 CPU Units, including introductory information, designing, installation, and maintenance. Mainly hardware information is provided.	An introduction to the entire NX701 system is provided along with the following information on the CPU Unit. <ul style="list-style-type: none"> • Features and system configuration • Introduction • Part names and functions • General specifications • Installation and wiring • Maintenance and inspection
NX-series NX1P2 CPU Unit Hardware User's Manual	W578	NX1P2-□□□□	Learning the basic specifications of the NX1P2 CPU Units, including introductory information, designing, installation, and maintenance. Mainly hardware information is provided.	An introduction to the entire NX1P2 system is provided along with the following information on the CPU Unit. <ul style="list-style-type: none"> • Features and system configuration • Introduction • Part names and functions • General specifications • Installation and wiring • Maintenance and inspection
NJ-series CPU Unit Hardware User's Manual	W500	NJ501-□□□□ NJ301-□□□□ NJ101-□□□□	Learning the basic specifications of the NJ-series CPU Units, including introductory information, designing, installation, and maintenance. Mainly hardware information is provided.	An introduction to the entire NJ-series system is provided along with the following information on the CPU Unit. <ul style="list-style-type: none"> • Features and system configuration • Introduction • Part names and functions • General specifications • Installation and wiring • Maintenance and inspection
NJ/NX-series CPU Unit Software User's Manual	W501	NX701-□□□□ NX1P2-□□□□ NJ501-□□□□ NJ301-□□□□ NJ101-□□□□	Learning how to program and set up an NJ/NX-series CPU Unit. Mainly software information is provided.	The following information is provided on NJ/NX-series CPU Units. <ul style="list-style-type: none"> • CPU Unit operation • CPU Unit features • Initial settings • Programming based on IEC 61131-3 language specifications
NX-series NX1P2 CPU Unit Built-in I/O and Option Board User's Manual	W579	NX1P2-□□□□	Learning about the details of functions only for an NX-series NX1P2 CPU Unit and an introduction of functions for an NJ/NX-series CPU Unit.	Of the functions for an NX1P2 CPU Unit, the following information is provided. <ul style="list-style-type: none"> • Built-in I/O • Serial Communications Option Boards • Analog I/O Option Boards An introduction of following functions for an NJ/NX-series CPU Unit is also provided. <ul style="list-style-type: none"> • Motion control functions • EtherNet/IP communications functions • EtherCAT communications functions
NJ/NX-series Instruc- tions Reference Manual	W502	NX701-□□□□ NX1P2-□□□□ NJ501-□□□□ NJ301-□□□□ NJ101-□□□□	Learning detailed specifications on the basic instructions of an NJ/NX-series CPU Unit.	The instructions in the instruction set (IEC 61131-3 specifications) are described.

Manual name	Cat. No.	Model numbers	Application	Description
NJ/NX-series CPU Unit Motion Control User's Manual	W507	NX701-□□□□ NX1P2-□□□□ NJ501-□□□□ NJ301-□□□□ NJ101-□□□□	Learning about motion control settings and programming concepts.	The settings and operation of the CPU Unit and programming concepts for motion control are described.
NJ/NX-series Motion Control Instructions Reference Manual	W508	NX701-□□□□ NX1P2-□□□□ NJ501-□□□□ NJ301-□□□□ NJ101-□□□□	Learning about the specifications of the motion control instructions that are provided by OMRON.	The motion control instructions are described.
NJ/NX-series CPU Unit Built-in EtherCAT® Port User's Manual	W505	NX701-□□□□ NX1P2-□□□□ NJ501-□□□□ NJ301-□□□□ NJ101-□□□□	Using the built-in EtherCAT port on an NJ/NX-series CPU Unit.	Information on the built-in EtherCAT port is provided. This manual provides an introduction and provides information on the configuration, features, and setup.
NJ/NX-series CPU Unit Built-in EtherNet/IP™ Port User's Manual	W506	NX701-□□□□ NX1P2-□□□□ NJ501-□□□□ NJ301-□□□□ NJ101-□□□□	Using the built-in EtherNet/IP port on an NJ/NX-series CPU Unit.	Information on the built-in EtherNet/IP port is provided. Information is provided on the basic setup, tag data links, and other features.
NJ-series CPU Unit OPC UA User's Manual	W588	NJ501-1□□0	Using the OPC UA.	Information on the OPC UA is provided.
NJ/NX-series Database Connection CPU Units User's Manual	W527	NX701-□□□20 NJ501-□□□20 NJ101-□□□20	Using the database connection service with NJ/NX-series Controllers	Describes the database connection service.
NJ-series SECS/GEM CPU Units User's Manual	W528	NJ501-1340	Using the GEM Services with NJ-series Controllers	Information is provided on the GEM Services.
NJ-series NJ Robotics CPU Unit User's Manual	W539	NJ501-4□□□	Controlling robots with NJ-series CPU Units.	Describes the functionality to control robots.
NJ/NY-series NC Integrated Controller User's Manual	O030	NJ501-5300 NY532-5400	Performing numerical control with NJ/NY-series Controllers.	Describes the functionality to perform the numerical control.
NJ/NY-series G code Instructions Reference Manual	O031	NJ501-5300 NY532-5400	Learning about the specifications of the G code/M code instructions.	The G code/M code instructions are described.
NJ/NX-series Troubleshooting Manual	W503	NX701-□□□□ NX1P2-□□□□ NJ501-□□□□ NJ301-□□□□ NJ101-□□□□	Learning about the errors that may be detected in an NJ/NX-series Controller.	Concepts on managing errors that may be detected in an NJ/NX-series Controller and information on individual errors are described.
Sysmac Studio Version 1 Operation Manual	W504	SYSMAC-SE2□□□	Learning about the operating procedures and functions of the Sysmac Studio.	Describes the operating procedures of the Sysmac Studio.
CNC Operator Operation Manual	O032	SYSMAC-RTNC0□□□D	Learning an introduction of the CNC Operator and how to use it.	An introduction of the CNC Operator, installation procedures, basic operations, connection operations, and operating procedures for main functions are described.
NX-series EtherCAT® Coupler Unit User's Manual	W519	NX-ECC□□□□	Learning how to use an NX-series EtherCAT Coupler Unit and EtherCAT Slave Terminals	The system and configuration of EtherCAT Slave Terminals, which consist of an NX-series EtherCAT Coupler Unit and NX Units, are described along with the hardware, setup, and functions of the EtherCAT Coupler Unit that are required to configure, control, and monitor NX Units through EtherCAT.
NX-series Data Reference Manual	W525	NX-□□□□□□□	Referencing lists of the data that is required to configure systems with NX-series Units.	Lists of the power consumptions, weights, and other NX Unit data that is required to configure systems with NX-series Units are provided.

Manual name	Cat. No.	Model numbers	Application	Description
NX-series NX Units User's Manuals	W521	NX-ID□□□□ NX-IA□□□□ NX-OC□□□□ NX-OD□□□□ NX-MD□□□□	Learning how to use NX Units	Describes the hardware, setup methods, and functions of the NX Units. Manuals are available for the following Units. Digital I/O Units, Analog I/O Units, System Units, Position Interface Units, Communications Interface Units, Load Cell Input Units, and IO-Link Master Units.
	W522	NX-AD□□□□ NX-DA□□□□ NX-TS□□□□		
	W523	NX-PD1□□□ NX-PF0□□□ NX-PC0□□□ NX-TBX□□		
	W524	NX-EC0□□□ NX-ECS□□□ NX-PG0□□□		
	W540	NX-CIF□□□		
	W566	NX-TS□□□□*1 NX-HB□□□□		
	W565	NX-RS□□□□		
W567	NX-ILM□□□			
NX-series Safety Control Unit User's Manual	Z930	NX-SL□□□□ NX-SI□□□□ NX-SO□□□□	Learning how to use NX-series Safety Control Units	Describes the hardware, setup methods, and functions of the NX-series Safety Control Units.
NX-series Safety Control Unit Instructions Reference Manual	Z931	NX-SL□□□□	Learning about the specifications of instructions for the Safety CPU Unit.	Describes the instructions for the Safety CPU Unit.
IO-Link System User's Manual	W570	NX-ILM□□□ GX-ILM□□□	Learning everything from an introduction to details about IO-Link Systems, including mainly software information common to all IO-Link masters, Support Software operating methods, and troubleshooting.	Introduces IO-Link Systems and describes system configurations, communications specifications, communications methods, I/O data, parameters, functions, Support Software, and troubleshooting.
GX-series EtherCAT Slave Units User's Manual	W488	GX-ID□□□□ GX-OD□□□□ GX-OC□□□□ GX-MD□□□□ GX-AD□□□□ GX-DA□□□□ GX-EC□□□□ XWT-ID□□ XWT-OD□□ GX-ILM□□□	Learning how to use the EtherCAT remote I/O terminals.	Describes the hardware, setup methods and functions of the EtherCAT remote I/O terminals.
MX2/RX Series Inverter EtherCAT Communication Unit User's Manual	I574	3G3AX-MX2-ECT 3G3AX-RX-ECT	Learning how to connect a 3G3AX-MX2-ECT or 3G3AX-RX-ECT EtherCAT Communications Unit for MX2/RX-series Inverters.	Describes the following information for the 3G3AX-MX2-ECT and 3G3AX-RX-ECT EtherCAT Communications Unit for MX2/RX-series Inverters: installation, parameter settings required for operation, troubleshooting, and inspection methods.
AC Servomotors/Servo Drives 1S-series with Built-in EtherCAT® Communications User's Manual	I586	R88M-1□ R88D-1SN□-ECT	Learning how to use the 1S-series AC Servomotors/Servo Drives with built-in EtherCAT Communications.	Describes the hardware, setup methods and functions of the AC Servomotors/Servo Drives with built-in EtherCAT Communications.
AC Servomotors/Servo Drives G5-series with Built-in EtherCAT® Communications User's Manual	I576	R88M-K□ R88D-KN□-ECT	Learning how to use the AC Servomotors/Servo Drives with built-in EtherCAT Communications.	Describes the hardware, setup methods and functions of the AC Servomotors/Servo Drives with built-in EtherCAT Communications. The linear motor type model and the model dedicated for position controls are available in G5-series.
	I577	R88L-EC-□ R88D-KN□-ECT-L		
EtherCAT Digital-type Sensor Communication Unit Operation Manual	E413	E3X-ECT	Learning how to connect E3X-series EtherCAT Slave Units.	Provides the specifications of and describes application methods for E3X-series EtherCAT Slave Units.

Manual name	Cat. No.	Model numbers	Application	Description
E3NW-ECT EtherCAT Digital Sensor Communications Unit Operation Manual	E429	E3NW-ECT	Learning how to connect E3NW EtherCAT Slave Units.	Provides the specifications of and describes application methods for E3NW EtherCAT Slave Units.
FQ-M-series Specialized Vision Sensor for Positioning User's Manual	Z314	FQ-MS12□	Learning how to connect FQ-M-series Specialized Vision Sensor for Positioning.	Describes the following information for the FQ-M-series Specialized Vision Sensor for Positioning: installation, wiring methods, parameter settings required for operation, troubleshooting, and inspection methods.
FH/FZ5 Vision System FH/FZ5 Series User's Manual for Communications Settings	Z342	FH-3□□□□ FH-1□□□□	Learning how to connect FH/FZ5-series Vision Systems	The functions, settings, and communications methods to communicate with FH/FZ5-series Vision Systems from a PLC or other external device are described.
ZW-CE1□T Confocal Fiber Type Displacement Sensor User's Manual	Z332	ZW-CE1□T	Learning how to connect ZW-CE1□T EtherCAT Slave Units.	Provides the specifications of and describes application methods for ZW-CE1□T EtherCAT Slave Units.
CJ-series Special Unit Manuals for NJ-series CPU Unit	W490	CJ1W-AD□□□ CJ1W-DA□□□ CJ1W-MAD42	Learning how to use CJ-series Units with an NJ-series CPU Unit.	The methods and precautions for using CJ-series Units with an NJ501 CPU Unit are described, including access methods and programming interfaces. Manuals are available for the following Units. Analog I/O Units, Insulated-type Analog I/O Units, Temperature Control Units, ID Sensor Units, High-speed Counter Units, Serial Communications Units, DeviceNet Units, EtherNet/IP Units, and CompoNet Master Units.
	W491	CJ1W-TC□□□		
	W492	CJ1W-CT021		
	W498	CJ1W-PDC15 CJ1W-PH41U CJ1W-AD04U		
	W493	CJ1W-CRM21		
	W494	CJ1W-SCU□□		
	W495	CJ1W-EIP21		
	W497	CJ1W-DRM21		
NA-series Programmable Terminal Hardware User's Manual	V117	NA5-□W□□□□	Learning the specifications and settings required to install an NA-series Programmable Terminals and connect peripheral devices.	Information is provided on NA-series Programmable Terminal specifications, part names, installation procedures, and procedures to connect an NA Unit to peripheral devices. Information is also provided on maintenance after operation and troubleshooting.
NA-series Programmable Terminal Software User's Manual	V118	NA5-□W□□□□	Learning about NA-series Programmable Terminal pages and object functions.	NA-series Programmable Terminal pages and object functions are described.
NS-series Programmable Terminals Programming Manual	V073	NS15-□□□□□ NS12-□□□□□ NS10-□□□□□ NS8-□□□□□ NS5-□□□□□	Learning how to use the NS-series Programmable Terminals.	Describes the setup methods, functions, etc. of the NS-series Programmable Terminals.

*1 Temperature Input Units are introduced in Cat. No. W522 before Cat. No. W566 is released.

Revision History

A manual revision code appears as a suffix to the catalog number on the front and back covers of the manual.

Cat. No. W503-E1-18

↑
Revision code

Revision code	Date	Revised content
01	July 2011	Original production
02	March 2012	Added information related to the upgrade to CPU unit version 1.01, made additions and changes to events related to the addition of devices that can be connected, and corrected mistakes.
03	May 2012	Added information related to the upgrade to CPU unit version 1.02, made additions and changes to events related to the addition of devices that can be connected, and corrected mistakes.
04	August 2012	Made additions to events and changes to the contents related to the upgrade to CPU unit version 1.03, and corrected mistakes.
05	February 2013	Made additions to events and changes to the contents related to the upgrade to CPU unit version 1.04, and corrected mistakes.
06	April 2013	Made additions to events and changes to the contents related to the upgrade to CPU unit version 1.05, and corrected mistakes.
07	June 2013	Made additions to events and changes to the contents related to the upgrade to CPU unit version 1.06, and corrected mistakes.
08	September 2013	Made additions to events and changes to the contents related to the upgrade to CPU unit version 1.07, and corrected mistakes.
09	December 2013	Made additions to events and changes to the contents related to the upgrade to CPU unit version 1.08, and corrected mistakes.
10	July 2014	Corrected mistakes.
11	January 2015	Made additions to events and changes to the contents related to the upgrade to CPU unit version 1.10, and corrected mistakes.
12	April 2015	Made additions to events and changes to the contents related to the addition of the NX701-□□□□ and NJ101-□□□□, and corrected mistakes.
13	April 2016	Made changes to the contents related to the upgrade to CPU unit version 1.11, and corrected mistakes.
14	July 2016	Made changes to the contents related to the upgrade to CPU unit version 1.12, and corrected mistakes.
15	October 2016	Made changes to the contents related to the upgrade to CPU unit version 1.13, and corrected mistakes.
16	April 2017	Made changes to the contents related to the upgrade to CPU unit version 1.14, and corrected mistakes.

17	October 2017	Made changes to the contents related to the upgrade to CPU unit version 1.16, added an error log table for CJ-series Special Units, and corrected mistakes.
18	January 2018	Made changes to the contents related to the upgrade to CPU unit version 1.17, and corrected mistakes.

1

Overview of Errors

This section provides information that is required to troubleshoot errors. It introduces the types of errors that can occur on an NJ/NX-series Controller, the operation that occurs in response to errors, and the methods you can use to check for errors. Refer to *Section 2 Error Troubleshooting Methods* for information on troubleshooting errors.

1-1 Overview of NJ/NX-series Errors	1-2
1-1-1 Types of Errors	1-3
1-1-2 CPU Unit Status	1-4
1-2 Fatal Errors	1-7
1-2-1 Types of Fatal Errors	1-7
1-2-2 Checking for Fatal Errors	1-8
1-3 Non-fatal Errors	1-9
1-3-1 Types of Non-fatal Errors	1-9
1-3-2 Checking for Non-fatal Errors	1-19
1-3-3 Resetting Non-fatal Errors	1-22

1-1 Overview of NJ/NX-series Errors

You manage all of the errors that occur on the NJ/NX-series Controller as events. The same methods are used for all events. This allows you to see what errors have occurred and find corrections for them with the same methods for the entire range of errors that is managed (i.e., CPU Unit, NX Units, NX-series Slave Terminals, EtherCAT slaves,* and CJ-series Units).

* Only Sysmac devices are supported. For information on EtherCAT slaves that are Sysmac devices, refer to the *NJ/NX-series CPU Unit Built-in EtherCAT Port User's Manual* (Cat. No. W505).

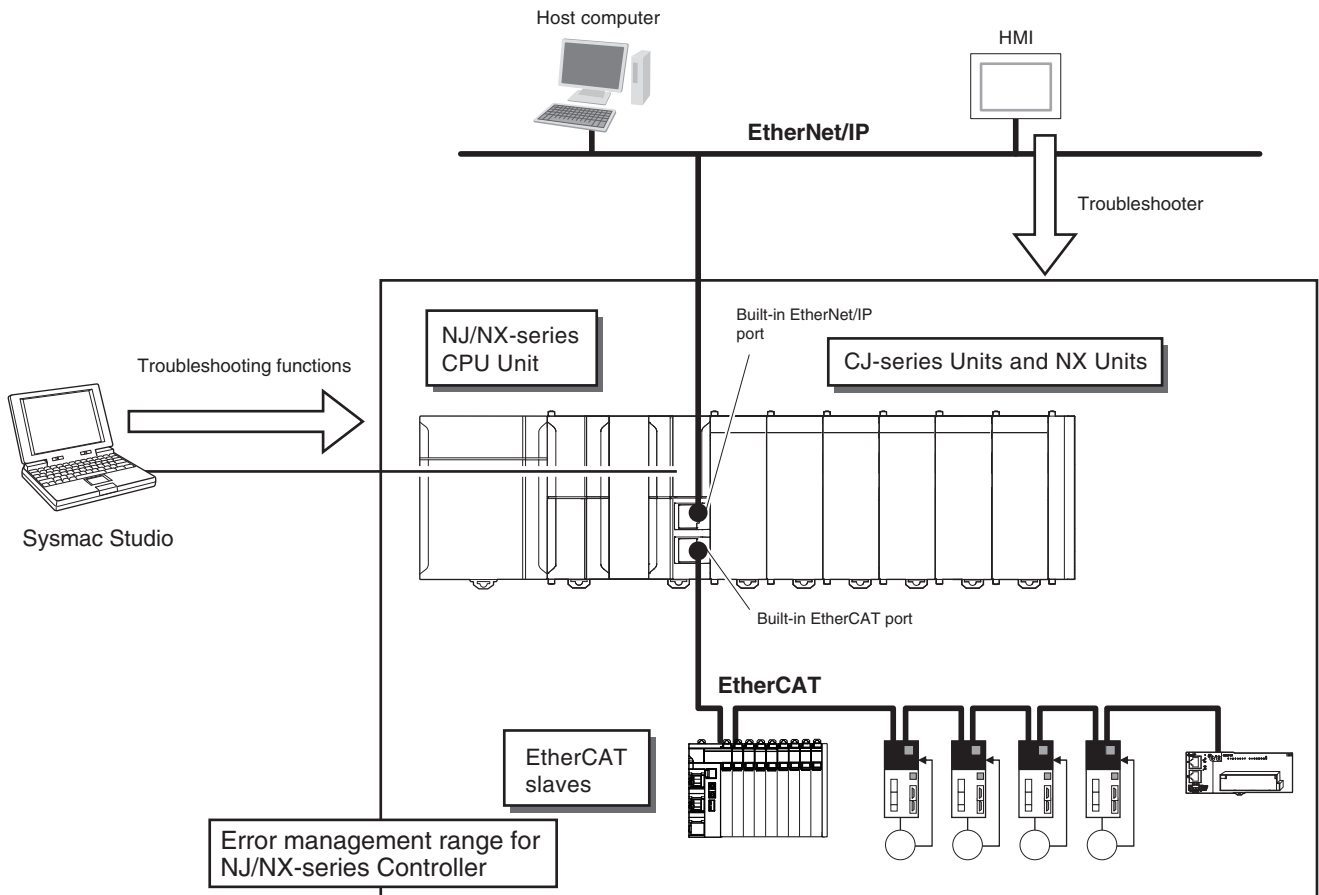

You can use the troubleshooting functions of the Sysmac Studio or the Troubleshooter on an HMI to quickly check for errors that have occurred and find corrections for them.

To perform troubleshooting from an HMI, connect the HMI to the built-in EtherNet/IP port on the CPU Unit.



Precautions for Correct Use

- CJ-series Units can be used only with an NJ-series CPU Unit.
- The only CPU Unit on which NX Units can be mounted is an NX1P2 CPU Unit.
- Refer to *A-1 Applicable Range of the HMI Troubleshooter* for the applicable range of the HMI Troubleshooter.

1-1-1 Types of Errors

There are two main types of errors (events) depending on whether the NJ/NX-series Controller can manage them or not.

● Fatal Errors

These errors are not detected by the event management function of the NJ/NX-series Controller because the CPU Unit stops operation. You cannot identify or reset these errors with the Sysmac Studio or an HMI.

Refer to *1-2 Fatal Errors* for error types and confirmation methods for fatal errors.

● Non-fatal Errors

These errors are detected and managed with the event management function of the NJ/NX-series Controller. You can confirm these errors with the Sysmac Studio or an HMI.

Refer to *1-3 Non-fatal Errors* for error types and confirmation methods for non-fatal errors.

1-1-2 CPU Unit Status

You can check the operating status of the CPU Unit with the PWR/POWER, RUN, and ERROR indicators on the front panels of the Power Supply Unit and CPU Unit.

● NX-series CPU Units

NX701 CPU Unit

Power Supply Unit

CPU Unit

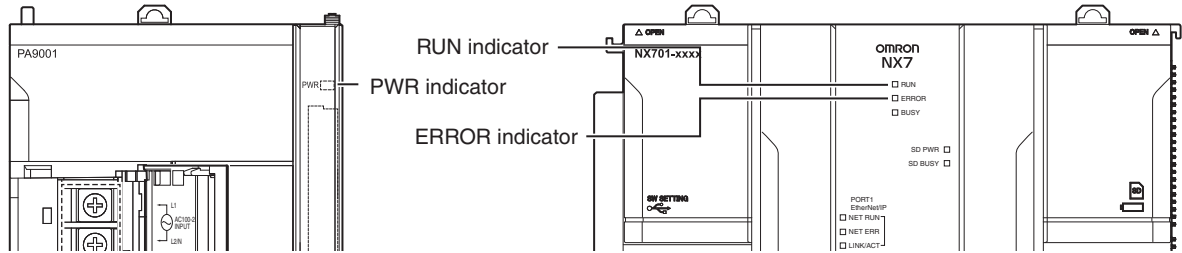

NX1P2 CPU Unit

CPU Unit

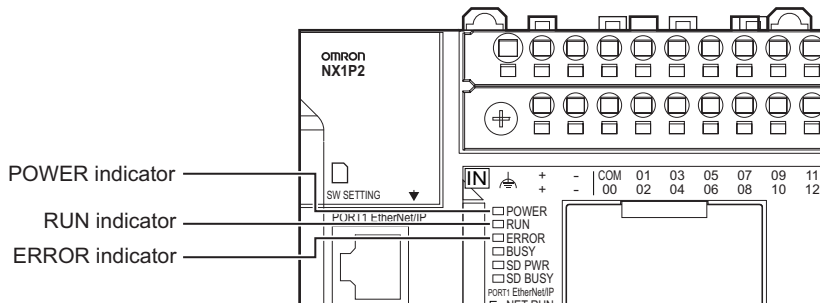

The following table shows the status of front-panel indicators, the status of user program execution, and the ability to connect communications to the Sysmac Studio or an HMI during startup, during normal operation, and when errors occur.

CPU Unit operating status		Power Supply Unit/ CPU Unit	CPU Unit		User program execution status	Communications with Sysmac Studio or HMI	
		PWR/ POWER (green)	RUN (green)	ERROR (red)			
Startup		Lit	Flashing (2-s intervals followed by 0.5-s intervals)	Not lit	Stopped.	Not possible.	
Normal operation	RUN mode	Lit	Lit	Not lit	Continues.	Possible.	
	PROGRAM mode	Lit	Not lit	Not lit	Stopped.		
Fatal error in CPU Unit		Power Supply Error*1	Not lit	Not lit	Not lit	Stopped.	Not possible.
		CPU Unit Reset*1*2 /Hardware Initialization Error*1*3	Lit	Not lit	Not lit	Stopped.	
		CPU Unit Error*1	Lit	Not lit or Flashing (2-s intervals or 0.5-s intervals)	Lit	Stopped.	
		System Initialization Error*1	Lit	Flashing (2-s intervals) for 30 s or longer	Not lit	Stopped.	
Non-fatal error in CPU Unit		Major fault*4	Lit	Not lit	Lit	Stopped.	Possible. (Communications can be connected from an HMI if EtherNet/IP is operating normally.)
		Partial fault*4	Lit	Lit	Flashing (1-s intervals)	Continues.*5	
		Minor fault*4	Lit	Lit	Flashing (1-s intervals)	Continues.	
		Observation*4	Lit	Lit	Not lit	Continues.	

*1 Refer to 1-2 *Fatal Errors* for information on individual errors.

*2 This error can occur for NX701 CPU Units. If the status of indicators shown above continues 30 seconds or longer, this error exists.

*3 This error can occur for NX1P2 CPU Units. If the status of indicators shown above continues 30 seconds or longer, this error exists.

*4 Refer to 1-3 *Non-fatal Errors* for information on individual errors.

*5 The function module where the error occurred stops.



Precautions for Correct Use

When an NX1P2 CPU Unit is used, a power shortage may occur at the CPU Rack depending on the configuration of NX Units mounted to the CPU Unit. If one of the followings occurs, use the Sysmac Studio to check if the power consumed by the Units on the CPU Rack exceeds the supplied power.

- The CPU Unit is operating but the mounted NX Units do not operate.
- Power is supplied to the CPU Unit, but the CPU Unit does not turn ON.

● NJ-series CPU Units

Power Supply Unit

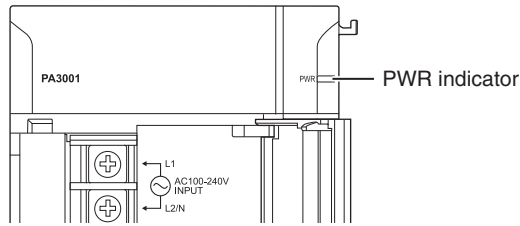

CPU Unit

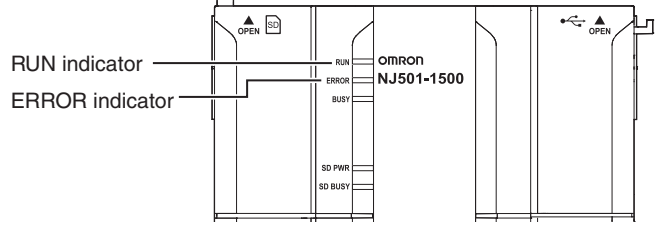

The following table shows the status of front-panel indicators, the status of user program execution, and the ability to connect communications to the Sysmac Studio or an HMI during startup, during normal operation, and when errors occur.

CPU Unit operating status		Power Supply Unit	CPU Unit		User program execution status	Communications with Sysmac Studio or HMI
		PWR (green)	RUN (green)	ERROR (red)		
Startup		Lit	Flashing (1-s intervals)	Not lit	Stopped.	Not possible.
Normal operation	RUN mode	Lit	Lit	Not lit	Continues.	Possible.
	PROGRAM mode	Lit	Not lit	Not lit	Stopped.	
Fatal error in CPU Unit	Power Supply Error*1	Not lit	Not lit	Not lit	Stopped.	Not possible.
	CPU Unit Reset*1	Lit	Not lit	Not lit	Stopped.	
	Incorrect Power Supply Unit Connected*1	Lit	Flashing (3-s intervals)	Lit	Stopped.	
	CPU Unit Watchdog Timer Error*1	Lit	Not lit	Lit	Stopped.	
Non-fatal error in CPU Unit	Major fault*2	Lit	Not lit	Lit	Stopped.	Possible. (Communications can be connected from an HMI if EtherNet/IP is operating normally.)
	Partial fault*2	Lit	Lit	Flashing (1-s intervals)	Continues.*3	
	Minor fault*2	Lit	Lit	Flashing (1-s intervals)	Continues.	
	Observation*2	Lit	Lit	Not lit	Continues.	

*1 Refer to 1-2 *Fatal Errors* for information on individual errors.

*2 Refer to 1-3 *Non-fatal Errors* for information on individual errors.

*3 The function module where the error occurred stops.

1-2 Fatal Errors

1-2-1 Types of Fatal Errors

This section describes the errors that cause the operation of the NJ/NX-series CPU Unit to stop. The errors that can occur depend on the CPU Unit.

Communications with the Sysmac Studio or an HMI are not possible if there is a fatal error in the Controller.

(Yes: Error that can occur)

Error name	CPU Unit		
	NX701	NX1P2	NJ-series
Power Supply Error	Yes	Yes	Yes
CPU Unit Reset	Yes		Yes
Hardware Initialization Error		Yes	
Incorrect Power Supply Unit Connected			Yes
CPU Unit Error	Yes	Yes	
CPU Unit Watchdog Timer Error			Yes
System Initialization Error	Yes	Yes	

The above errors are described in detail as follows.

● Power Supply Error

Power is not supplied, the voltage is outside of the allowed range, or the Power Supply Unit or power supply section is faulty.

● CPU Unit Reset

The CPU Unit stopped operation because of a hardware error. For an NJ-series CPU Unit, this error can also occur for reasons other than hardware failures, as given below.

- The power supply to an Expansion Rack is OFF.
- The I/O Connecting Cable is incorrectly installed.
 - The IN and OUT connectors are reversed.
 - The connectors are not mated properly.
- There is more than one I/O Control Unit on the CPU Rack or there is an I/O Control Unit on an Expansion Rack.

● Hardware Initialization Error

This error can occur for an NX1P2 CPU Unit. It indicates a data error in minimum programs required to initialize the hardware. Only the POWER indicator will be lit while the CPU Unit is starting, but if it is lit for 30 seconds or longer, then this error occurs.

● Incorrect Power Supply Unit Connected

There is a CJ-series Power Supply Unit connected to the NJ-series CPU Unit. The operation of the Controller is stopped.

● **CPU Unit Watchdog Timer Error**

This error can occur for an NJ-series CPU Unit. This error occurs when the watchdog timer times out because of a hardware failure or when temporary data corruption causes the CPU Unit to hang.

● **CPU Unit Error**

This error can occur for an NX-series CPU Unit. It indicates that there is a hardware failure or that the CPU is running out of control due to temporary data corruption.

● **System Initialization Error**

This error can occur for an NX-series CPU Unit. It indicates a hardware failure or data error. The RUN indicator will flash at 2-second intervals while the CPU Unit is starting, but if it flashes for 30 seconds or longer, then this error occurs.

1-2-2 Checking for Fatal Errors

You can identify fatal errors based on the status of the PWR/POWER, RUN, and ERROR indicators, as well as by the ability to connect communications to the Sysmac Studio. Refer to *Section 2 Error Troubleshooting Methods* for information on identifying errors and corrections.

● **NX-series CPU Units**

Indicators			Communications with Sysmac Studio	CPU Unit operating status
PWR/POWER (green)	RUN (green)	ERROR (red)		
Not lit	Not lit	Not lit	Not possible.*	Power Supply Error
Lit	Not lit	Not lit		CPU Unit Reset/Hardware Initialization Error
Lit	Not lit or Flashing (2-s intervals or 0.5-s intervals)	Lit		CPU Unit Error
Lit	Flashing (2-s intervals) for 30 s or longer	Not lit		System Initialization Error

* An online connection to the Sysmac Studio is necessary to differentiate between CPU Unit Resets/Hardware Initialization Errors, CPU Unit Errors, and non-fatal errors in the CPU Unit. Power Supply Errors and System Initialization Errors can be differentiated with the indicators. There is no need to see if you can go online with the CPU Unit from the Sysmac Studio.

● **NJ-series CPU Units**

Indicators			Communications with Sysmac Studio	CPU Unit operating status
PWR (green)	RUN (green)	ERROR (red)		
Not lit	Not lit	Not lit	Not possible.*	Power Supply Error
Lit	Not lit	Not lit		CPU Unit Reset
Lit	Flashing (3-s intervals).	Lit		Incorrect Power Supply Unit Connected
Lit	Not lit	Lit		CPU Unit Watchdog Timer Error

* An online connection to the Sysmac Studio is necessary to differentiate between CPU Unit Resets, CPU Unit Watchdog Timer Errors, and non-fatal errors in the CPU Unit. Power Supply Errors and Incorrect Power Supply Unit Connected errors can be differentiated with the indicators. There is no need to see if you can go online with the CPU Unit from the Sysmac Studio.

1-3 Non-fatal Errors

Non-fatal errors that occur are managed as events in the NJ/NX-series Controller. You can check the event to find out what type of error occurred.

1-3-1 Types of Non-fatal Errors

Overview of Controller Events (Errors and Information)

You use the same methods to manage all of the events that occur on the NJ/NX-series Controller. The events that occur are saved in the CPU Unit or NX-series Slave Terminals.

You can use the Sysmac Studio or an HMI to confirm current Controller events and the log of events that occurred before. This log is called an event log.

To use an HMI to check events, connect the HMI to the built-in EtherNet/IP port on the CPU Unit.

The event management for NX-series Units is shown below.

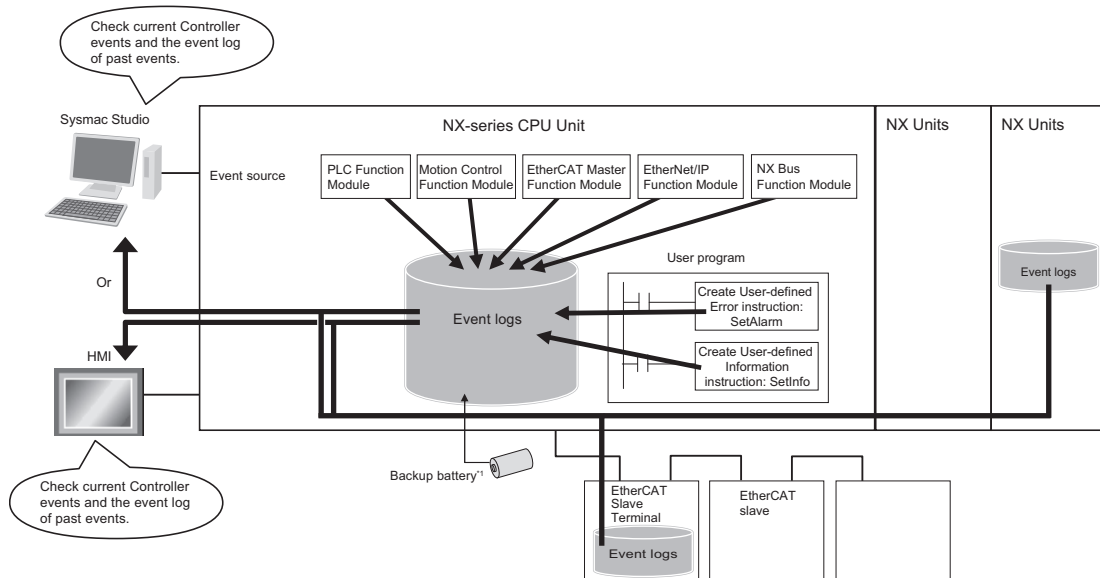

*1. For NX701, the event logs are saved in battery-backup memory. For NX1P2, they are saved in non-volatile memory.



Precautions for Correct Use

- The only CPU Unit on which NX Units can be mounted is an NX1P2 CPU Unit.

The event management for NJ-series Units is shown below.

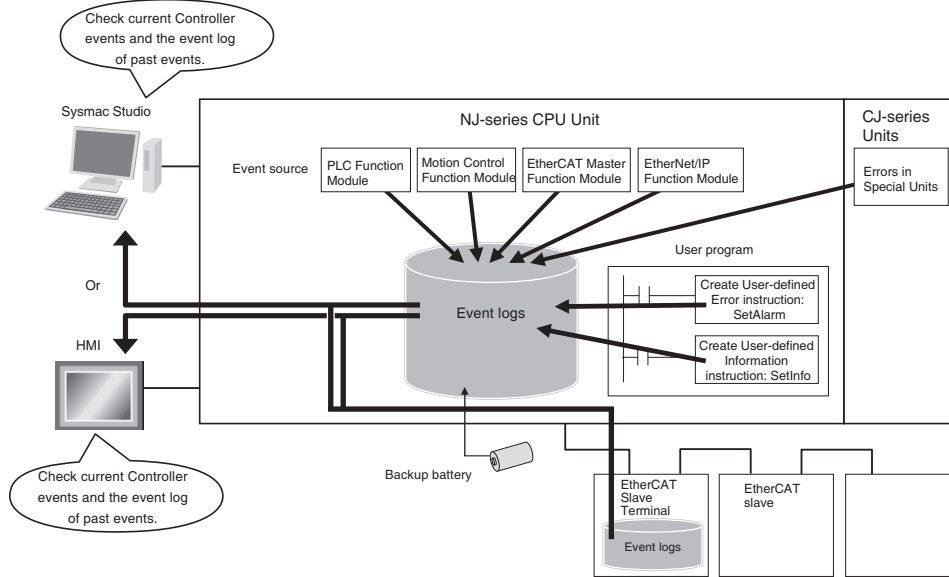

Precautions for Correct Use

For an NX-series or NJ-series CPU Unit, use the following information to handle errors that occurred in an EtherCAT Slave Terminal or EtherCAT slave.

- Refer to the manual for the Communications Coupler Unit for details on the event log in a Slave Terminal.
- When there is an emergency message that notifies an error from an EtherCAT slave to the CPU Unit, it is recorded in the event log of the EtherCAT Master Function Module as the Emergency Message Detected (64200000 hex) event.
- You cannot confirm the event log for an EtherCAT slave that has no event log. To record an error history as an event, you have to change the setting of the EtherCAT slave to notify emergency messages, then the Emergency Message Detected (64200000 hex) event is recorded. However, errors which cannot be notified by emergency messages from EtherCAT slaves are not recorded in the event log. Meanwhile, there is a way to display error history of some EtherCAT slaves that do not have the event log, on the Sysmac Studio version 1.15 or higher as the event log. Refer to relevant manuals for EtherCAT slaves for the possibility to display error history as the event log.
- Refer to relevant manuals for the slaves for the procedures to read error history of EtherCAT slaves.

The following events can occur.

● **Controller Events**

The Controller automatically detects these events. Controller events include events for the function modules in the CPU Unit, NX Units, NX-series Slave Terminal, EtherCAT slaves, and CJ-series Units.



Additional Information

- You cannot check the error logs that are managed independently by EtherCAT slaves because they are not for Controller events. Refer to relevant manuals for the slaves for the procedures to read error logs and correct errors.
- Error causes and corrections are not displayed on the Controller Event Log Tab Page in the Sysmac Studio, although error codes, which are registered in the error logs that are managed independently by CJ-series Special Units, are displayed. Refer to relevant manuals for the Units for the procedures to read error logs and correct errors.

● User-defined Events

These are events that occur in applications that the user developed.

Refer to the *NJ/NX-series CPU Unit Software User's Manual* (Cat. No. W501) for information on user-defined events.

Non-fatal errors are managed as Controller events. This section describes mainly the Controller events.

Details on Controller Events (Errors and Information)

● Controller Event Times

The time of occurrence is recorded when an event occurs.

The times of occurrence are based on the CPU Unit's built-in clock data.

For events that occur in EtherCAT Slave Terminals, the times of occurrence are recorded based on the CPU Unit's built-in clock data that the EtherCAT Slave Terminal receives from the CPU Unit.

If the EtherCAT Slave Terminal cannot obtain the clock data from the CPU Unit, the time of occurrence on the Sysmac Studio is displayed as ----/-- --:--:--. For an event occurred before the EtherCAT Slave Terminal obtains the clock data from the CPU Unit, the time of occurrence is also displayed as ----/-- --:--:--.



Version Information

If the EtherCAT Slave Terminal cannot obtain the clock data from the CPU Unit or an event occurred before the EtherCAT Slave Terminal obtains the clock data from the CPU Unit, the time of occurrence is displayed as *1970/1/1 0:00:00* with Sysmac Studio version 1.14 or lower.

● Sources of Controller Events

The *Event* source information indicates the location where an event occurred. The event source identifies the particular function module in the CPU Unit in which the event occurred. For some function modules, there is more detailed information about the event source. This information is called the *Source details*. The following information is provided as the event source details.

Event source	Source details
PLC Function Module	Instructions, power supply, built-in I/O, Option Board, I/O bus master, or CJ-series Unit
NX Bus Function Module *1	Master or NX Unit
Motion Control Function Module	Common, axis, or axes group
EtherCAT Master Function Module	Communications port, EtherCAT master, EtherCAT Coupler Unit, NX Unit, or EtherCAT slave
EtherNet/IP Function Module	Communications port, communications port 1, communications port 2, CIP, CIP1, CIP2, FTP, NTP, or SNMP

*1 Only for NX1P2 CPU Units.

Note An NC Integrated Controller has the CNC Function Module. For how to check and correct errors in the CNC Function Module, refer to the *NJ/NY-series NC Integrated Controller User's Manual* (Cat. No. O030).

The event source is displayed on the Sysmac Studio or HMI.

● Levels of Controller Events (Errors and Information)

The following table classifies the levels of Controller events according to the effect that the errors have on control.

No.	Level	Classification	Level name
1	↑ High ↓	Controller errors	Major fault level
2			Partial fault level
3			Minor fault level
4			Observation
5	Low	Controller information	Information

Errors with a higher level have a greater impact on the functions that the NJ/NX-series Controller provides, and are more difficult to recover from. When an event occurs, the Sysmac Studio or HMI will display the level name.

Event Levels

- **Major Fault Level**
These errors prevent control operations for the entire Controller. When the CPU Unit detects a major fault, it immediately stops the execution of the user program and turns OFF the loads of all slave, including remote I/O. With EtherCAT slaves, some NX Units, and some CJ-series Special Units, you can set the slave settings or Unit settings to select whether outputs will go OFF or retain their previous status. You cannot reset major fault level errors from the user program, the Sysmac Studio or an HMI. To recover from a major fault level error, remove the cause of the error, and either cycle the power supply to the Controller, or reset the Controller from the Sysmac Studio.
- **Partial Fault Level**
These errors prevent control operations in a certain function module in the Controller. The NJ/NX-series CPU Unit continues to execute the user program even after a partial fault level error occurs. You can include error processing in the user program in order to stop equipment safely. After you remove the cause of the error, execute one of the following to return to normal status.
 - Reset the error from the user program, the Sysmac Studio, or an HMI.
 - Cycle the power supply.
 - Reset the Controller from the Sysmac Studio.
- **Minor Fault Level**
These errors prevent part of the control operations in a certain function module in the Controller. The troubleshooting for minor fault level errors is the same as the processing for partial fault level errors.
- **Observations**
These errors do not affect the control operations of the Controller. The observation notifies you of potential problems before they develop into a minor fault level error or worse.
- **Information**
Events that are classified as information provide information that do not indicate errors.

You can change the event level for some events. Refer to the *NJ/NX-series CPU Unit Software User's Manual* (Cat. No. W501) for details on changing event levels. Refer to *3-1 Errors by Source* in this manual to see the events for which you can change the event level.

Operation for Each Level

The way that the Controller operates when an event occurs depends on the level of the Controller event.

Item	Level of event					
	Controller errors				Controller information	
	Major fault level	Partial fault level	Minor fault level	Observation	Information	
Definition	These errors are serious errors that prevent control operations for the entire Controller.	These errors prevent all of the control in a function module other than PLC Function Module.	These errors prevent part of the control operations in a certain function module.	These errors do not affect system control operations.	These are not errors, but appear in the event log to notify the user of specific information.	
Event examples (Only a few examples are provided here. Refer to Section 3 Error Tables for a list of all of the errors.)	<ul style="list-style-type: none"> Non-volatile Memory Data Corrupted (PLC Function) 	<ul style="list-style-type: none"> Motion Control Period Exceeded (Motion Control Function Module) Communications Controller Failure (EtherCAT Master Function Module) 	<ul style="list-style-type: none"> Positive Limit Input Detected (Motion Control Function Module) Low Battery Voltage (PLC Function Module) 	<ul style="list-style-type: none"> Packet Discarded Due to Full Reception Buffer (EtherNet/IP Function Module) 	<ul style="list-style-type: none"> Power Turned ON Power Interrupted Memory All Cleared 	
Front-panel indicators*1	PWR/POWER (green)	Lit	Lit	Lit	Lit	Lit
	RUN (green)	Not lit	Lit	Lit	Lit	Lit
	ERROR (red)	Lit	Flashes at 1-s intervals.	Flashes at 1-s intervals.	Not lit	Not lit
NJ/NX-series CPU Unit operation	RUN output on Power Supply Unit	OFF	ON	ON	ON	ON
	User program execution status	Stops.	Continues.*2	Continues.	Continues.	Continues.
	Outputs turned OFF	Yes	No	No	No	No
	Error reset	Not possible.	Depends on the nature of the error.	Depends on the nature of the error.	---	---
	Event logs	Recorded. (Some errors are not recorded.)	Recorded.	Recorded.	Recorded.	Recorded.

Item	Level of event				
	Controller errors				Controller information
	Major fault level	Partial fault level	Minor fault level	Observation	Information
Outputs from EtherCAT slaves and Basic Output Units	Refer to <i>I/O Operation for Major Fault Level Controller Errors</i> on page 1-16.	<ul style="list-style-type: none"> Errors in EtherCAT Master Function Module: Depends on settings in the slave. Errors in other function modules: According to user program. 	According to user program.	According to user program.	According to user program.
Sysmac Studio display (when online)	Error messages are automatically displayed in the Controller Status Pane. The user can display detailed information in the Troubleshooting Dialog Box.			These items are not displayed in the error display in the Controller Status Pane.	

*1 If multiple Controller errors have occurred, the indicators show the error with the highest event level.

*2 Operation stops in the function module (NX Bus Function Module, Motion Control Function Module, EtherCAT Master Function Module, or EtherNet/IP Function Module) in which the error occurred.

Operation in the Function Module Where an Error Event Occurred

Function module	Level of current event			
	Major fault level	Partial fault level	Minor fault level	Observation
PLC Function Module	User program execution stops.	---	Operation continues.	
NX Bus Function Module	---	I/O refreshing for NX bus communications stops. (NX Unit operation depends on the NX Unit settings.)	Operation continues. If an NX Unit error occurs, operation depends on the fail-soft operation settings.	Operation continues.
Motion Control Function Module	---	All axes stop. (The stop method depends on the error.)	<ul style="list-style-type: none"> The affected axes/axes group stops. (The stop method depends on the settings.) The motion control instruction is not executed (for instructions related to axis operation.) 	<ul style="list-style-type: none"> Axis operation continues. The motion control instruction is not executed (for instructions not related to axis operation).
EtherCAT Master Function Module	---	EtherCAT communications stop. (The slaves operate according to the settings in the slaves.)	I/O refreshing for EtherCAT communications stops or continues according to the fail-soft operation settings in the master. (If I/O refreshing stops, the slaves operate according to the settings in the slaves.)	I/O refreshing for EtherCAT communications continues.
EtherNet/IP Function Module	---	EtherNet/IP communications stop. (Online connections to the Sysmac Studio and communications connections with an HMI is not possible.)	Part of EtherNet/IP communications stop. (Online connections to the Sysmac Studio and communications connections with an HMI is possible if the online connections or communications connection is not the cause of the error.)	EtherNet/IP communications continue.

I/O Operation for Major Fault Level Controller Errors

The following table gives the operation of the CPU Unit and the I/O devices.

Unit	CPU Unit operation	Unit or slave operation
NX Unit mounted to the CPU Unit *1	Input refreshing stops.	Depends on the settings for the NX Unit.
Built-in I/O *1	<ul style="list-style-type: none"> • Depends on the Load Rejection Output Setting. • Input refreshing stops. 	---
Option Board *1	<ul style="list-style-type: none"> • Outputs turned OFF. Output values depend on the specifications of the Option Board. • Input refreshing stops. 	Analog I/O Option Board <ul style="list-style-type: none"> • Output value: 0 V
NX-series Slave Terminal	The NX-series Slave Terminal moves to Safe-Operational state.	Depends on the NX Unit settings.
EtherCAT slave *2	The slave is placed in the Safe-Operational state.	Depends on the slave settings. *3
Servo Drive or NX Unit assigned to an axis	Updating the command values is stopped.	All axes stop immediately.
CJ-series Basic I/O Unit *4	<ul style="list-style-type: none"> • The values of all outputs are cleared to zero. • Input refreshing continues. 	<ul style="list-style-type: none"> • All outputs are turned OFF. • External inputs are refreshed.
CJ-series Special Unit *4	Refreshing continues.	Depends on the Unit operating specifications.
Devices connected with EtherNet/IP	<ul style="list-style-type: none"> • For the originators of tag data links, the variables and I/O memory addresses for input (consume) tags are not refreshed. • For the targets of tag data links, operation depends on the settings of the tags sets for the output (produce) tags. *5 	Depends on the specifications of the connected devices.

*1 This applies to an NX1P2 CPU Unit.

*2 Excluding Servo Drives assigned to an axis.

*3 Settings and setting methods depend on the slave. Refer to the manual for the slave. For a Servo Drive, operation depends on the setting of object 605E hex (Fault Reaction Option Code).

*4 This applies to an NJ-series CPU Unit.

*5 You can set whether to clear output or maintain the data from before the error occurred. Refer to the *NJ/NX-series CPU Unit Built-in EtherNet/IP Port User's Manual* (Cat. No. W506) for details.

The following table gives the operation of the CPU Unit and the I/O devices for the following errors that occur for an NJ-series Unit.

- Unsupported Unit Detected
- I/O Bus Check Error
- End Cover Missing
- Incorrect Unit/Expansion Rack Connection
- Duplicate Unit Number
- Too Many I/O Points
- I/O Setting Check Error

Unit	CPU Unit operation	Unit or slave operation
EtherCAT Slave Terminal	The EtherCAT Slave Terminal moves to Safe-Operational state.	Depends on the NX Unit settings.
EtherCAT slave *1	The slave is placed in the Safe-Operational state.	Depends on the slave settings. *2
Servo Drive or NX Unit assigned to an axis	Updating the command values is stopped.	All axes stop immediately.
CJ-series Basic I/O Unit	Refreshing is stopped.	<ul style="list-style-type: none"> All outputs are turned OFF. All inputs are turned OFF.
CJ-series Special Unit	Refreshing is stopped.	Depends on the Unit operating specifications (the ERH indicator lights).
Devices connected with EtherNet/IP	<ul style="list-style-type: none"> For the originators of tag data links, the variables and I/O memory addresses for input (consume) tags are not refreshed. For the targets of tag data links, operation depends on the settings of the tags sets for the output (produce) tags. *3 	Depends on the specifications of the connected devices.

*1 Excluding Servo Drives assigned to an axis.

*2 Settings and setting methods depend on the slave. Refer to the manual for the slave. For a Servo Drive, operation depends on the setting of object 605E hex (Fault Reaction Option Code).

*3 You can set whether to clear output or maintain the data from before the error occurred. Refer to the *NJ/NX-series CPU Unit Built-in EtherNet/IP Port User's Manual* (Cat. No. W506) for details.

● Event Code

Events that occur in a Controller have an event code. When an event occurs, the Sysmac Studio or HMI will display the event code. You can use the instructions that get error status to read the error codes of current errors from the user program.

The event codes are 8-digit hexadecimal values. The first digit of a Controller event represents its category. These categories are listed in the table below.

First digit of the code (hex)	Classification	Meaning
0	Hardware errors	An error caused by a hardware problem such as an internal part malfunction, contact failure, temperature error, undervoltage, overvoltage, or overcurrent.
1	Data errors	An error caused by incorrectly saved data or data corruption in the Controller.
2	Hardware setting errors	An error caused by incorrect handling of hardware settings (e.g., hardware switches) or restrictions (e.g., Unit assignment locations).
3	Configuration errors	An error caused by incorrect parameter values, parameters and hardware configurations that do not match, or configurations set by the user.
4	Software errors	An error caused by Controller software.
5	User software errors	An error that is caused by the user program. (For example, an input value to an instruction that is out of range.)
6	Observation errors	An error that was detected in monitoring operation that occurs due to user settings in the Controller. (For example, if the task period is exceeded or if a position outside of the motion range is detected.)
7	Control errors	An error caused by a control process. (For example, if the operating status does not meet the required conditions or if the timing is incorrect.)

First digit of the code (hex)	Classification	Meaning
8	Communications errors	An error caused by communications with an external device or host system.
9	Information	Events that are classified as information and provide information that do not indicate errors.

Relationship between Event Codes and Error Codes

In addition to the event codes that indicate errors, the function modules and Units have their own error codes. If there are corresponding event and error codes, you can tell what the other code is if you know either one of them. This allows you to know when the same error is being given when you check errors with more than one method.

The following table shows the relationship between the error codes and event codes.

Error code (4-digit hexadecimal)		Corresponding event code (8-digit hexadecimal)		Example: Event code for an error code of A123 hex
Classification	Used in	Upper 4 digits	Lower 4 digits	
Error codes in the Motion Control Function Module	<ul style="list-style-type: none"> <i>ErrorID</i> output variable for motion control instructions System-defined variables for motion control* 	Error code	0000 hex	A1230000 hex
Error codes for basic instructions, OPC UA instructions, DB Connection instructions, GEM instructions and CNC instructions.	<i>ErrorID</i> output variable for each instructions	5401 hex	Error code	5401A123 hex
Error codes for robot control function	<ul style="list-style-type: none"> <i>ErrorID</i> output variable for robot instructions System-defined variables for motion control* 	Error code	0000 hex	A1230000 hex
Error codes in CJ-series Special Units	Error logs from CJ-series Special Units	0000 hex	Error code	0000A123 hex

* The following are system-defined variables for motion control:

Variable	Name
<code>_MC_COM.PFaultLvl.Code</code>	MC Common Partial Fault Code
<code>_MC_COM.MFaultLvl.Code</code>	MC Common Minor Fault Code
<code>_MC_COM.Obsr.Code</code>	MC Common Observation Code
<code>_MC_AX[].MFaultLvl.Code</code>	Axis Minor Fault Code
<code>_MC_AX[].Obsr.Code</code>	Axis Observation Code
<code>_MC_GRP[].MFaultLvl.Code</code>	Axes Group Minor Fault Code
<code>_MC_GRP[].Obsr.Code</code>	Axes Group Observation Code

● Exporting the Error Log

You can use the Sysmac Studio or an HMI to export the displayed event log to a CSV file. Refer to the *NJ/NX-series CPU Unit Software User's Manual* (Cat. No. W501) for information on exporting event logs

1-3-2 Checking for Non-fatal Errors

Checking Methods

Use the following methods to check for non-fatal errors.

Checking method	What you can check
Checking the indicators	You can use the indicators to confirm the Controller error level, the error status of the EtherCAT Master Function Module, and the error status of the EtherNet/IP Function Module.
Checking with the Troubleshooting Function of Sysmac Studio	You can check for current Controller errors, a log of past Controller errors, error sources, error causes, and corrections. You can also check error logs from CJ-series Special Units.* ¹
Checking with the Troubleshooter of an HMI* ²	You can check for current Controller errors, a log of past Controller errors, error sources, error causes, and corrections.
Instructions that read function module error status	You can check the highest-level status and highest-level event code in the current Controller errors.
Checking with system-defined variables	You can check the current Controller error status for each function module.

*¹ Detailed information, such as error causes and corrections, is not displayed.

*² To perform troubleshooting from an HMI, connect the HMI to the built-in EtherNet/IP port on the CPU Unit. Refer to *A-1 Applicable Range of the HMI Troubleshooter* for the applicable range of the HMI Troubleshooter.

This section describes the above checking methods.

Checking the Indicators

● Checking the Level of a Controller Error

You can use the PWR/POWER, RUN, and ERROR indicators to determine the level of an error. The following table shows the relationship between the Controller's indicators and the event level.

Indicators			Event level
PWR/POWER (green)	RUN (green)	ERROR (red)	
Lit	Not lit	Lit	Major fault level
Lit	Lit	Flashing (1-s intervals).	Partial fault level
Lit	Lit	Not lit	Minor fault level
Lit	Lit	Not lit	Observation

● Checking the Status of EtherCAT and EtherNet/IP Ports

For the EtherCAT and EtherNet/IP ports, use the EtherCAT and EtherNet/IP NET ERR indicators to determine whether an error that affects process data communications has occurred and whether a minor fault level error or higher-level error has occurred. The indicators let you check the status given in the following table.

Indicators	Indicated status
EtherCAT NET ERR	EtherCAT Port Status <ul style="list-style-type: none"> • Lit: Errors for which normal status cannot be recovered through user actions (i.e., errors for which you must replace the CPU Unit or contact your OMRON representative). • Flashing: Errors for which normal status can be recovered through user actions. • Not lit: An error that affects process data communications has not occurred.

Indicators	Indicated status
EtherNet/IP NET ERR	EtherNet/IP Port Status <ul style="list-style-type: none"> • Lit: Errors for which normal status cannot be recovered through user actions (i.e., errors for which you must replace the CPU Unit or contact your OMRON representative). • Flashing: Errors for which normal status can be recovered through user actions. • No lit: There are no minor fault level or higher-level errors.

Checking with the Troubleshooting Function of Sysmac Studio

When an error occurs, you can connect the Sysmac Studio online to the Controller to check current Controller errors and the log of past Controller errors.

● Current Errors

Open the Sysmac Studio's Controller Error Tab Page to check the current error's level, source, source details, event name, event code, details, attached information 1 to 4, actions, and corrections. Errors are not displayed for observations.

● Log of Past Errors

Open the Sysmac Studio's Controller Event Log Tab Page to check the times, levels, sources, source details, event names, event codes, details, attached information 1 to 4, actions, and corrections for previous errors.

Error logs from CJ-series Special Units are displayed on the Controller Event Log Tab Page. Detailed information is not displayed. To check detailed information, use the event codes that are displayed and refer to the error codes that are given in the manual for the relevant Unit. The relationship between error codes and event codes is described in *Details on Controller Events (Errors and Information)* under *1-3-1 Types of Non-fatal Errors*.

Refer to the *Sysmac Studio Version 1 Operation Manual* (Cat. No. W504) for details on troubleshooting with the Sysmac Studio.

Checking with the Troubleshooter of an HMI

When an error occurs, if you can connect communications between an HMI and the Controller, you can check current Controller errors and the log of past Controller errors.

To perform troubleshooting from an HMI, connect the HMI to the built-in EtherNet/IP port on the CPU Unit.



Precautions for Correct Use

Refer to *A-1 Applicable Range of the HMI Troubleshooter* for the applicable range of the HMI Troubleshooter.

● Current Errors

You can check the current error's event name, event code, level, source, source details, time, details, and attached information 1 to 4.

Also, observations are not displayed as errors.

● Log of Past Errors

You can check the time, level, source, source details, event name, event code, details, attached information 1 to 4 for past errors.

Refer to the relevant HMI manual for information on the HMI Troubleshooter.

Instructions That Read Function Module Error Status

You can determine the error status with the instructions that get error status provided for each function module from the user program. These instructions get the status and the event code of the error with the highest level.

Applicable function module	Instruction name	Instruction
PLC Function Module	Get PLC Controller Error Status	GetPLCError
	Get I/O Bus Error Status	GetCJBError
NX Bus Function Module	Get NX Bus Error Status	GetNXBError
	Get NX Unit Error Status	GetNXUnitError
Motion Control Function Module	Get Motion Control Error Status	GetMCError
EtherCAT Master Function Module	Get EtherCAT Error Status	GetECEError
EtherNet/IP Function Module	Get EtherNet/IP Error Status	GetEIPEError

Note An NC Integrated Controller has the CNC Function Module. For how to check and correct errors in the CNC Function Module, refer to the *NJ/NY-series NC Integrated Controller User's Manual* (Cat. No. O030).

For details on the instructions that get error status, refer to the *NJ/NX-series Instructions Reference Manual* (Cat. No. W502).

Checking with System-defined Variables

You can check the Error Status variable in the system-defined variables to determine the status of errors in a Controller. You can read the Error Status variable from an external device by using communications. Refer to the *NJ/NX-series CPU Unit Software User's Manual* (Cat. No. W501) for information on system-defined variables.

1-3-3 Resetting Non-fatal Errors

Unless you reset an error, the CPU Unit will retain the error status until you turn OFF the power supply to the Controller or reset the Controller.

To reset a Controller error, it is necessary to eliminate the cause of the error. The same error will occur again if you reset the error, but do not eliminate the cause of the error.



Precautions for Safe Use

Always confirm safety at the connected equipment before you reset Controller errors with an event level of partial fault or higher for the EtherCAT Master Function Module. When the error is reset, all slaves that were in any state other than Operational state (in which outputs are disabled) due to the Controller error with an event level of partial fault or higher will go to Operational state and the outputs will be enabled. Before you reset all errors, confirm that no Controller errors with an event level of partial fault have occurred for the EtherCAT Master Function Module.

Always confirm safety at the connected equipment before you reset Controller errors for a CJ-series Special Unit. When the Controller error is reset, the Unit where the Controller error with an event level of observation or higher will be restarted. Before you reset all errors, confirm that no Controller errors with an event level of observation or higher have occurred for the CJ-series Special Unit. Observation level events do not appear on the Controller Error Tab Page, so it is possible that you may restart the CJ-series Special Unit without intending to do so. You can check the status of the `_CJB_UnitErrSta[0,0]` to `_CJB_UnitErrSta[3,9]` Error Status variables on a Watch Tab Page to see if an observation level Controller error has occurred.



Precautions for Correct Use

Resetting an error is not the same as eliminating the cause of the error. Always eliminate the cause of an error before you perform the procedure to reset the error.

Error Resetting Methods

Method	Operation	Errors that are reset	Description
Commands from Sysmac Studio	Resetting Controller errors	Resetting all errors in the entire Controller	Reset the Controller errors from the Sysmac Studio's Troubleshooting Dialog Box.
		Resetting all Slave Terminal errors	Refer to the manual for the Communications Coupler Unit for details on resetting errors in a Slave Terminal.
		Resetting errors for individually specified NX Units	For NX Units connected to the NX bus of the CPU Unit, reset the Controller error individually from the Sysmac Studio's Troubleshooting Dialog Box. Refer to the manual for the Communications Coupler Unit for details on resetting errors individually for NX Units mounted to a Slave Terminal.
	Downloading	Resetting all errors for a specific function module	After the causes of the Controller errors are removed, all Controller errors in the relevant function module are reset as a result. Errors are not reset when you download the Controller Configurations and Setup.
	Clear All Memory	Resetting all errors for all function modules	After the causes of the Controller errors are removed, all Controller errors in all function modules are reset as a result. Errors for Slave Terminals are not reset.*1
	Controller reset		After the causes of the Controller errors are removed, all Controller errors in all function modules are reset as a result. Errors for Slave Terminals are not reset.*1
	Clear All Memory operation for Slave Terminal	Resetting all Slave Terminal errors	If the causes for the Controller errors are removed, all Controller errors in the Slave Terminals are reset.
Restarting the Slave Terminal			
Commands from an HMI*2	Resetting Controller errors	Resetting all errors in the entire Controller	Reset Controller errors from the Troubleshooter of an HMI. You can reset errors from an HMI that is not directly compatible with the NJ/NX-series Controller or another company's HMI if you use the HMI in combination with the reset error instruction for the function module in the user program.
Commands from the user program	Resetting Controller errors	Resetting errors for individual function modules	Execute the reset error instruction for the function module in the user program. <ul style="list-style-type: none"> For the Motion Control Function Module, you can reset all errors, errors for a particular axis, or errors for a particular axes group. For the NJ-series I/O bus, you can reset all errors or just the errors for a particular Unit. For the NX Bus Function Module, only resetting all errors is possible.
Commands from a host computer	Resetting Controller errors with CIP messages	Resetting all errors for all function modules	Use a CIP message from a host computer to reset errors.

Method	Operation	Errors that are reset	Description
Cycling the Controller's power supply	---	Resets all errors.	After the causes of the Controller errors are removed, all Controller errors in all function modules are reset as a result.
Cycling the power supply to the Slave Terminal	---	Resetting all Slave Terminal errors	If the causes for the Controller errors are removed, all Controller errors in the Slave Terminals are reset.

*1 Some errors are reset when the EtherCAT communications link is established rather than when the reset operation is performed.

*2 To reset errors from an HMI, connect the HMI to the built-in EtherNet/IP port on the CPU Unit.

Refer to the *Sysmac Studio Version 1 Operation Manual* (Cat. No. W504) for details on clearing errors from the Sysmac Studio.

2

Error Troubleshooting Methods

This section describes troubleshooting methods for specific errors.

2-1	Troubleshooting Flowcharts	2-2
2-1-1	Checking to See If the CPU Unit Is Operating	2-2
2-1-2	Troubleshooting Flowchart for Non-fatal Errors	2-4
2-2	Troubleshooting Fatal Errors	2-5
2-3	Troubleshooting Non-fatal Errors	2-7
2-3-1	Identifying and Resetting Errors with the Sysmac Studio	2-7
2-3-2	Identifying and Resetting Errors with an HMI	2-11
2-3-3	Identifying and Resetting Errors from the User Program	2-14
2-3-4	Checking for Errors with System-defined Variables	2-16
2-4	Troubleshooting When You Cannot Go Online from the Sysmac Studio	2-18
2-4-1	Causes and Correction When You Cannot Go Online from the Sysmac Studio	2-18
2-4-2	Troubleshooting for Each Cause	2-20

2-1 Troubleshooting Flowcharts

This section provides basic error identification and troubleshooting flowcharts. Use them when an error occurs in the NJ/NX-series Controller.

2-1-1 Checking to See If the CPU Unit Is Operating

When an error occurs in the NJ/NX-series Controller, use the following flowchart to determine whether the error is a fatal error or a non-fatal error.

Whenever possible, set the Sysmac Studio's software connection method in the flowchart to a direct USB connection if the CPU Unit has a USB (peripheral) port. If you use Ethernet, there are many reasons that prevent a software connection from the Sysmac Studio, so time is required to determine if a fatal or non-fatal error has occurred. If you cannot go online from the Sysmac Studio, perform *2-4 Troubleshooting When You Cannot Go Online from the Sysmac Studio* before you assume that the error is a fatal error.

● NX-series CPU Units

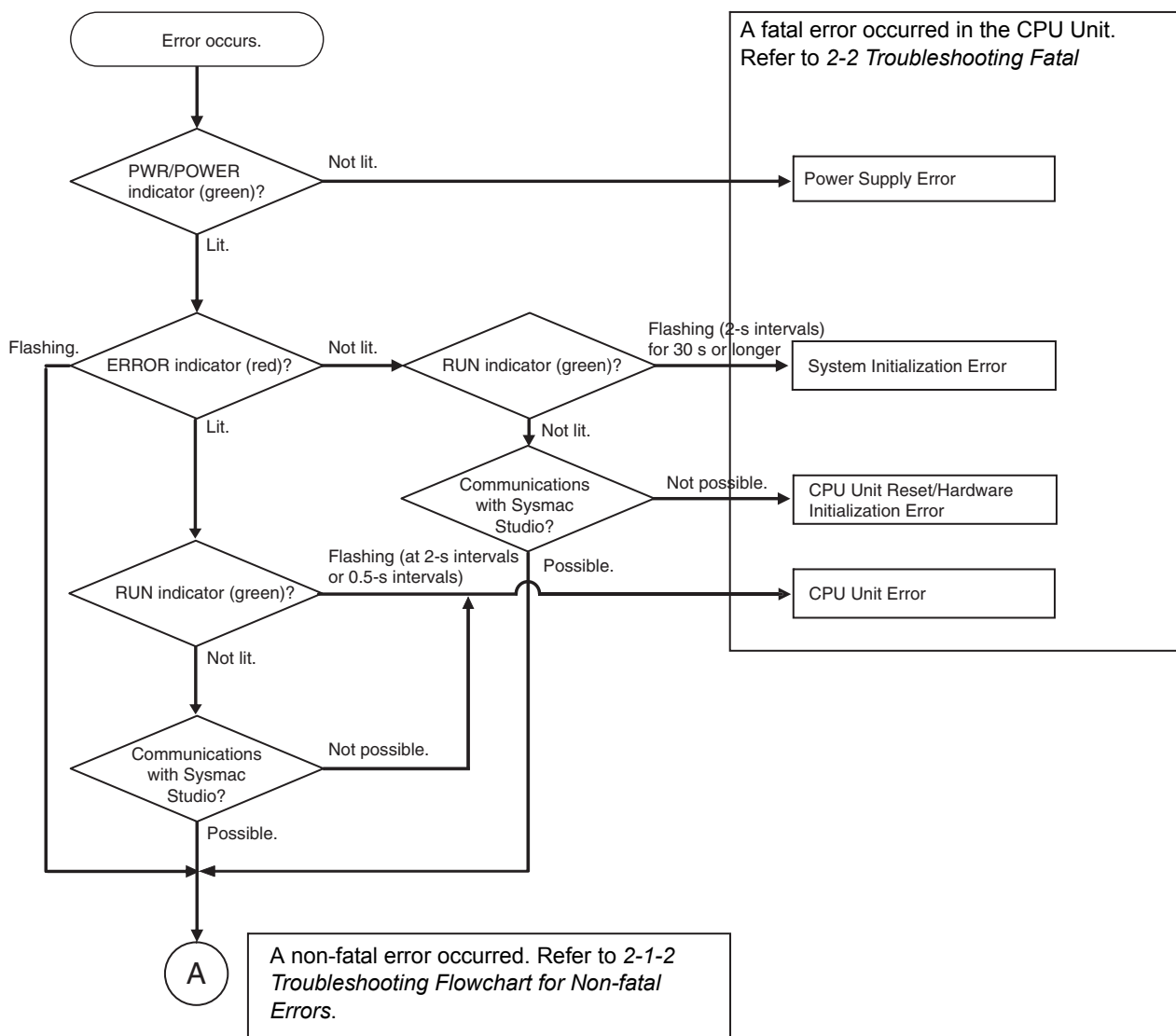

● **NJ-series CPU Units**

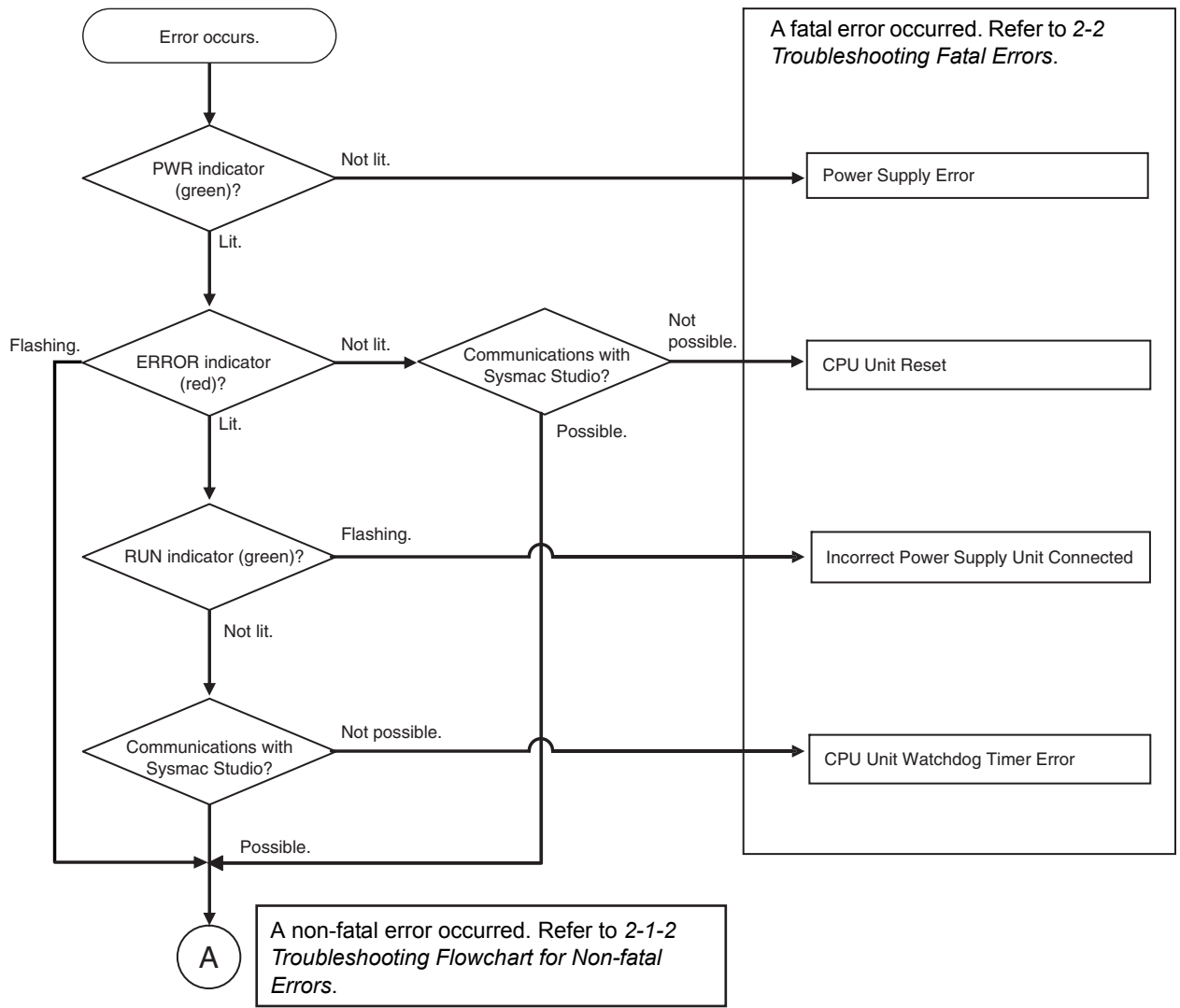

2-1-2 Troubleshooting Flowchart for Non-fatal Errors

For a non-fatal error, use the Sysmac Studio or an HMI to troubleshoot the error with the following flowchart. You can use the indicators to check the following:

- Level
- Whether the error is in the EtherNet/IP port or the EtherCAT port
- If the sources of the error is the EtherNet/IP port or the EtherCAT port, whether you can restore normal status yourself

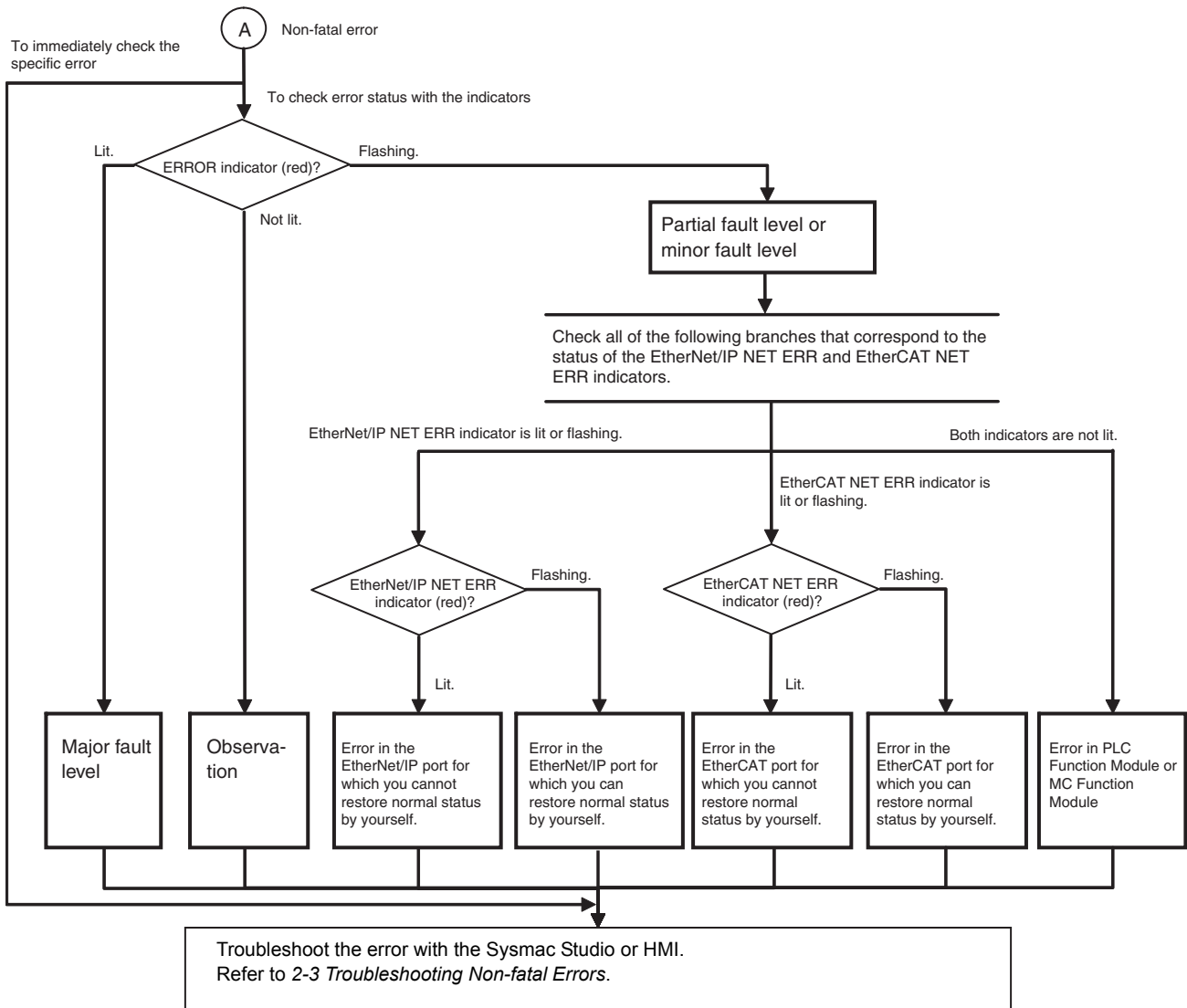

Precautions for Correct Use

Refer to A-1 *Applicable Range of the HMI Troubleshooter* for the applicable range of the HMI Troubleshooter.

2-2 Troubleshooting Fatal Errors

The section describes the procedure to troubleshoot fatal errors.

● Power Supply Error

Cause	Correction
Power is not being input.	Turn ON the power.
The voltage is outside of the allowable range for the power supply.	Check the Controller's power supply system, and correct it so that the voltage is within the allowable range.
Power supply system error caused by mounted Unit	Remove the Units from the CPU Rack one by one. If the error is eliminated, replace that Unit.
Power Supply Unit failure (CPU Units other than NX1P2)	If the error persists even after you make the above corrections, replace the Power Supply Unit.
Power supply section failure (NX1P2 CPU Unit)	If the error persists even after you make the above corrections, replace the CPU Unit.

● System Initialization Error

Cause	Correction
A conductive object has gotten inside.	If there is conductive material nearby, blow out the CPU Unit with air.
Noise	If the error did not result from the above causes, cycle the power to the Controller and see if that resets the error. If the error occurs frequently, check the FG and power supply lines to see if noise is entering on them. Implement noise countermeasures as required.
CPU Unit failure	If the error persists even after you make the above corrections, replace the CPU Unit.

● CPU Unit Reset

Cause	Correction
A conductive object has gotten inside.	If there is conductive material nearby, blow out the CPU Unit with air.
The power supply to an Expansion Rack is OFF.	Supply the correct voltage to the Power Supply Unit on the Expansion Rack.
The I/O Connecting Cable is incorrectly installed.	Correct the connection of the I/O Connecting Cable.
Noise	If the error did not result from the above causes, cycle the power to the Controller and see if that resets the error. If the error occurs frequently, check the FG and power supply lines to see if noise is entering on them. Implement noise countermeasures as required.
Power Supply Unit failure	If the error persists even after you make the above corrections, replace the Power Supply Unit.
CPU Unit failure	If the error persists even after you make the above corrections, replace the CPU Unit.

● Hardware Initialization Error

Cause	Correction
A conductive object has gotten inside.	If there is conductive material nearby, blow out the CPU Unit with air.
Noise	If the error did not result from the above causes, cycle the power to the Controller and see if that resets the error. If the error occurs frequently, check the FG and power supply lines to see if noise is entering on them. Implement noise countermeasures as required.
CPU Unit failure	If the error persists even after you make the above corrections, replace the CPU Unit.

● Incorrect Power Supply Unit Connected

Cause	Correction
A CJ-series Power Supply Unit is connected to an NJ-series CPU Unit.	Connect an NJ-series Power Supply Unit to the NJ-series CPU Unit.

● CPU Unit Error

Cause	Correction
A conductive object has gotten inside.	If there is conductive material nearby, blow out the CPU Unit with air.
Noise	If the error did not result from the above causes, cycle the power to the Controller and see if that resets the error. If the error occurs frequently, check the FG and power supply lines to see if noise is entering on them. Implement noise countermeasures as required.
CPU Unit failure	If the error persists even after you make the above corrections, replace the CPU Unit.

● CPU Unit Watchdog Timer Error

Cause	Correction
A conductive object has gotten inside.	If there is conductive material nearby, blow out the CPU Unit with air.
Noise	If the error did not result from the above causes, cycle the power to the Controller and see if that resets the error. If the error occurs frequently, check the FG and power supply lines to see if noise is entering on them. Implement noise countermeasures as required.
CPU Unit failure	If the error persists even after you make the above corrections, replace the CPU Unit.

2-3 Troubleshooting Non-fatal Errors

2-3-1 Identifying and Resetting Errors with the Sysmac Studio

Troubleshooting functions are provided by the Sysmac Studio. You can use the troubleshooting functions to identify errors that occur in a Controller, and reset the errors.

Displaying Errors on the Sysmac Studio

If an error occurs while the Sysmac Studio is online with the CPU Unit, the Sysmac Studio notifies the user of the error in the Controller Status Pane. From there, you can open the Troubleshooting and Event Logs Window to read detailed error information and troubleshooting methods.

Click the **Troubleshooting** Button in the toolbar, or select **Troubleshooting** from the Tools Menu.

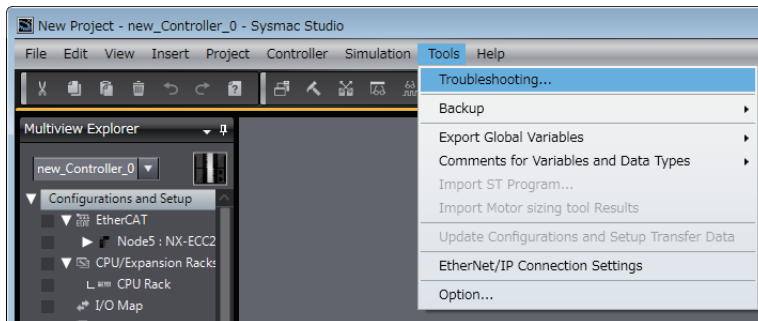

The Sysmac Studio automatically collects the Controller's error information, and opens the Troubleshooting Window.

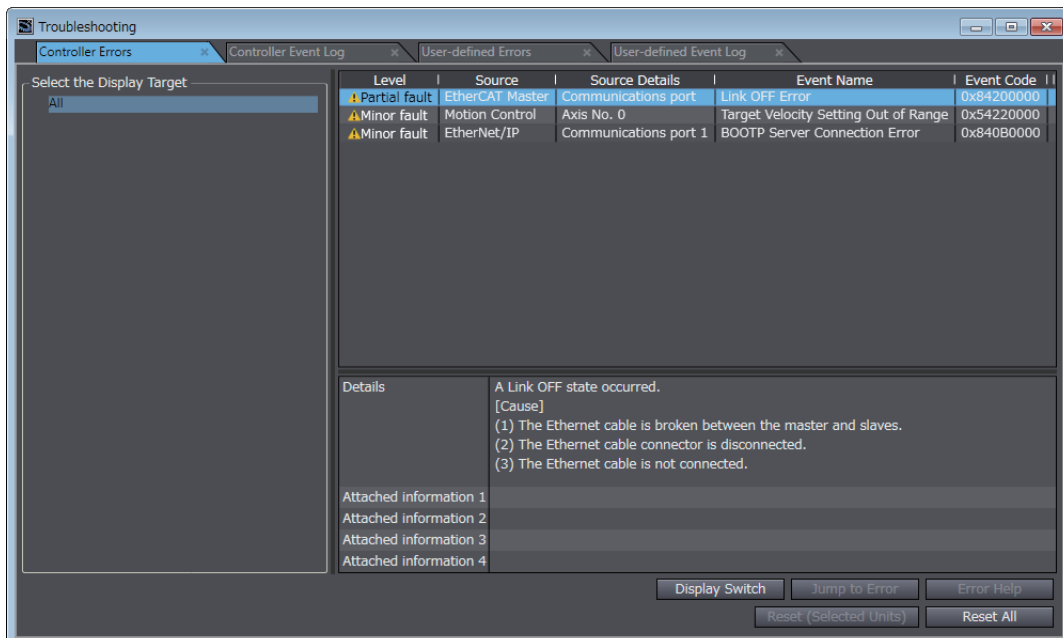

Checking Current Errors and the Event Logs with the Sysmac Studio

● Checking Current Errors with the Sysmac Studio

You can click the **Controller Errors** Tab in the Troubleshooting Window to read information on current errors in the Controller.

The Controller Errors Tab Page lists the current errors in order of their levels.

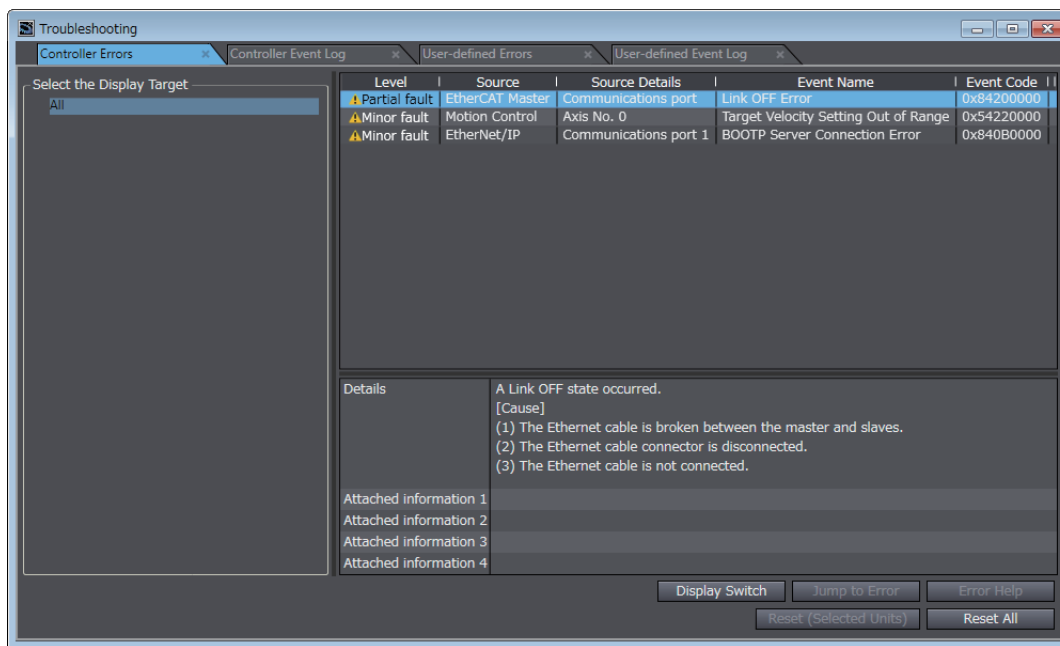

Display item	Description
Level	This is the event level of the error.
Source and Source Details	This is the physical location and functional location of the error.
Event Name	Error name
Event Code	This is the code of the error.

You can click the column headings in the Controller error list, such as the *Level* or *Source*, to reorder the table rows according to that heading. For example, the following change occurs when you click the *Source* heading.

Before *Source* heading is clicked.

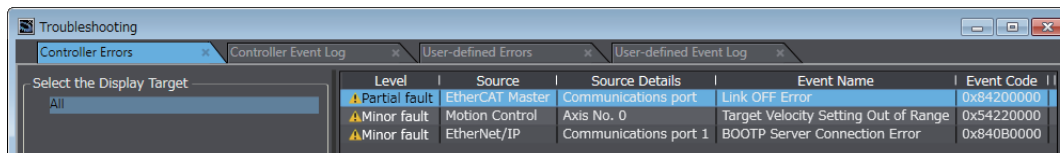

After *Source* heading is clicked.

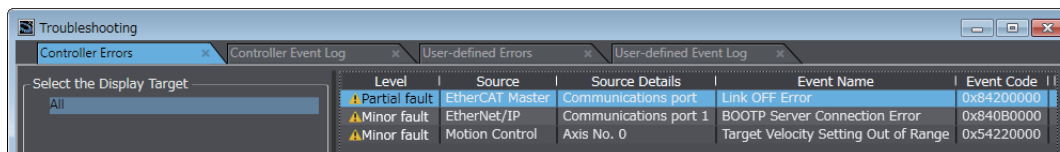

● Displaying Event Logs with the Sysmac Studio

With Sysmac Studio, you can check a log of the Controller events that previously occurred on the Controller Event Log Tab Page.

You can select the event logs and levels to display in the Display Settings Area. Information on the events that you specify are displayed in the detailed information area.

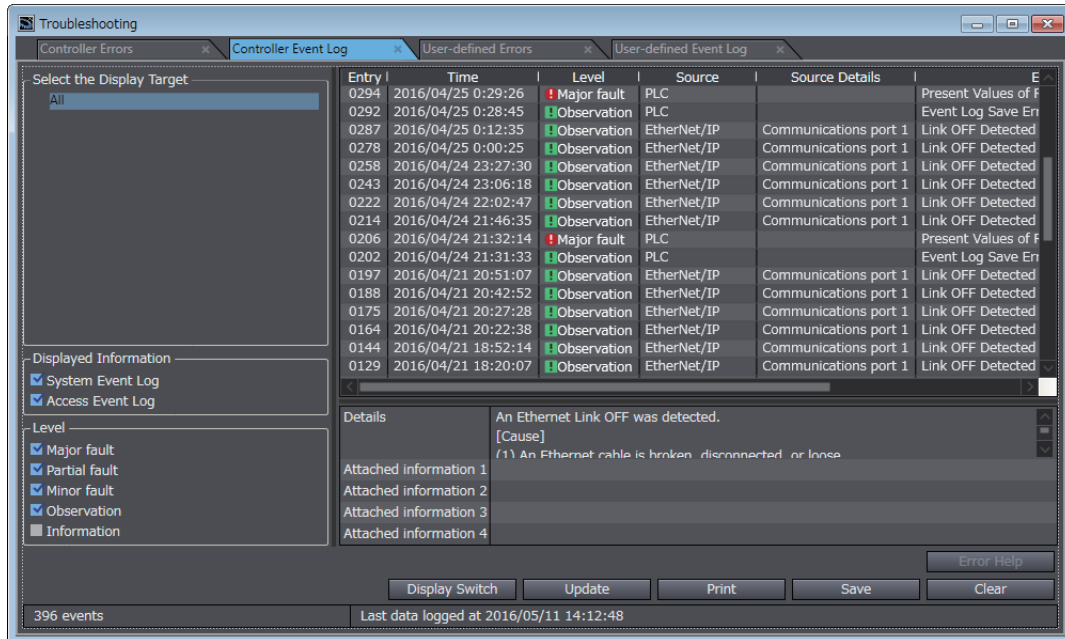

Error logs from CJ-series Special Units are displayed on the Controller Event Log Tab Page. Detailed information is not displayed. To check detailed information, use the event codes that are displayed and refer to the error codes that are given in the manual for the relevant Unit. The relationship between error codes and event codes is described in *Details on Controller Events (Errors and Information)* under *1-3-1 Types of Non-fatal Errors*.

Resetting Errors with the Sysmac Studio

You can use the Sysmac Studio to reset errors that occur in a Controller. With a CPU Unit with unit version 1.05 or later and Sysmac Studio version 1.06 or higher you can also reset errors for individual Units.

Before you attempt to reset a Controller error, isolate and remove the cause of the error.

The Troubleshooting Dialog Box displays the cause, source, and corrections for the error. You can select any of the items from the error list to display the following information about that error. Click the **Display Switch** Button to switch between displaying details and attached information and displaying actions and corrections.

Display item	Description
Details	Detailed information on the error is displayed, such as the probable causes.
Attached information 1 through 4	Detailed information about the source of the error is displayed.
Action and Correction	Methods to correct the probable causes of the error are displayed.

After confirming the cause of the displayed error and the conditions in which it occurred, perform the displayed error corrections to eliminate the cause of the error.

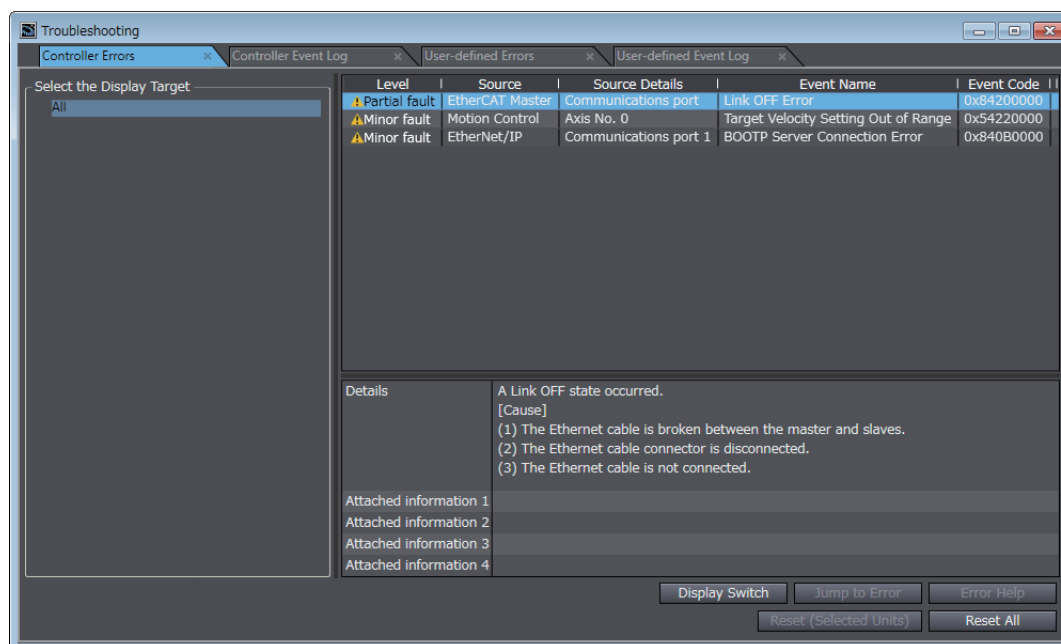

To eliminate the cause of the error, first select the item to perform from the *Action and Correction* list. When you select the appropriate step in the *Action and Correction* list, either the **Jump to Error** or **Error Help** Button is enabled, depending on the contents. In some cases, neither button will operate. Click the enabled button, and proceed with the displayed troubleshooting steps.

After you complete all of the troubleshooting steps for the current errors, click the **Reset (Selected Units)** or **Reset All** Button to reset all of the current errors. If the cause of the error is not removed, or if the power supply is not cycled or the Controller is not reset as required after resetting the error, the error will occur again.

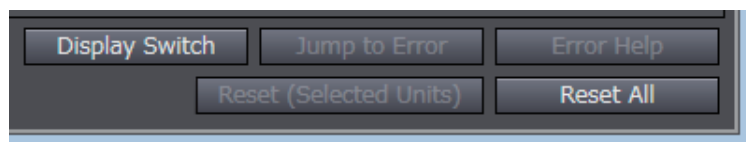

Button	Description
Jump to Error	This button is enabled when the error correction involves a change in the Sysmac Studio settings. When you click the button, the Sysmac Studio will automatically switch to the Editing Pane.
Error Help	The correction methods or the attached information is displayed if it is not possible to jump to the settings display.
Reset (Selected Units)	This button resets the current errors in the selected Unit.
Reset All	This button resets all of the current errors, and reads errors again.

It is necessary to synchronize the data between the Sysmac Studio and the connected CPU Unit before you use the **Jump to Error** Button.

For details on synchronization, refer to the *Sysmac Studio Version 1 Operation Manual* (Cat. No. W504)

If you have enabled the verification of operation authority, it is necessary to confirm your authority before you can reset Controller errors.

The Operator, Maintainer, Designer, and Administrator have the authority to reset errors. For an Operator, however, verification is required each time.

Refer to the *NJ/NX-series CPU Unit Software User's Manual* (Cat. No. W501) for information on operation authority.

The Controller errors in all function modules are reset when you reset the Controller from the Sysmac Studio. If the cause of the error is not removed, the error will occur again.

2-3-2 Identifying and Resetting Errors with an HMI

You can connect an OMRON HMI to an NJ/NX-series CPU Unit through an EtherNet/IP network, and use it to read and reset errors that occurred in the Controller. (The Troubleshooter of the HMI is used.)

To perform troubleshooting from an HMI, connect the HMI to the built-in EtherNet/IP port on the CPU Unit.



Precautions for Correct Use

Refer to *A-1 Applicable Range of the HMI Troubleshooter* for the applicable range of the HMI Troubleshooter.

Checking for Current Errors with an HMI

You can check for errors in the Controller using the Troubleshooter of an HMI. You can also use the Troubleshooter to read detailed error information and corrections for current errors.

Refer to the relevant HMI manual for details on the HMI Troubleshooter.

The following example demonstrates the procedure used to check for errors with an NA-series HMI.

You can check the names and status of all connected Controllers in the Controller Status Screen of the NJ/NX Troubleshooter of the NA-series HMI. If there is an error, "Error" is displayed as the status of the Controller.

Controllers	Controller Event Status	User Event Status
new_Controller_0	Error	Normal
new_Controller_1	Normal	Normal

Buttons: Show Controller Events, Show User Events

Select the Controller with an error and click the **Show Controller Events** Button to display the Controller Event List Screen. In the Controller Event List Screen, you can check the list of Controller errors that currently exist in the selected Controller.

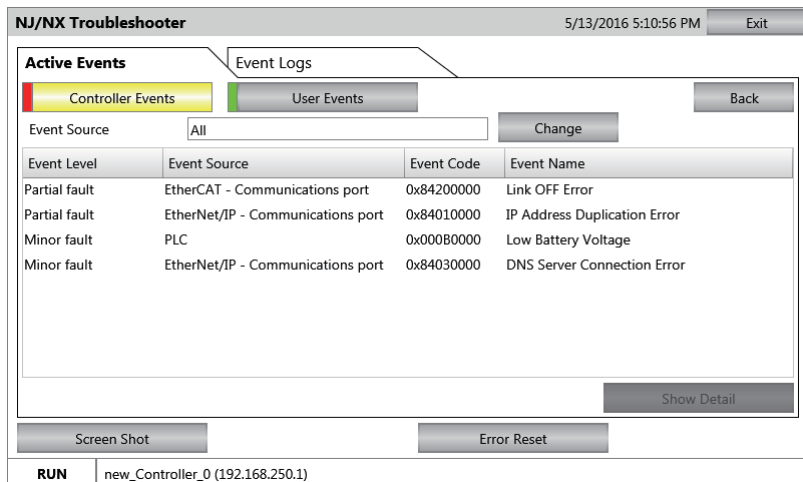

Resetting Errors with an HMI

You can use the Troubleshooter in an HMI to reset errors that occur in the Controller. Before you attempt to reset a Controller error, isolate and remove the cause of the error.

The following example demonstrates the procedure used to check for errors with an NA-series HMI.

Select an event in the Controller Event List Screen and click the **Show Detail** Button to display error's causes and corrections. In the Details Screen, information such as the error's causes and corrections are displayed.

After you confirm the cause of the displayed error, perform the steps in the displayed correction.

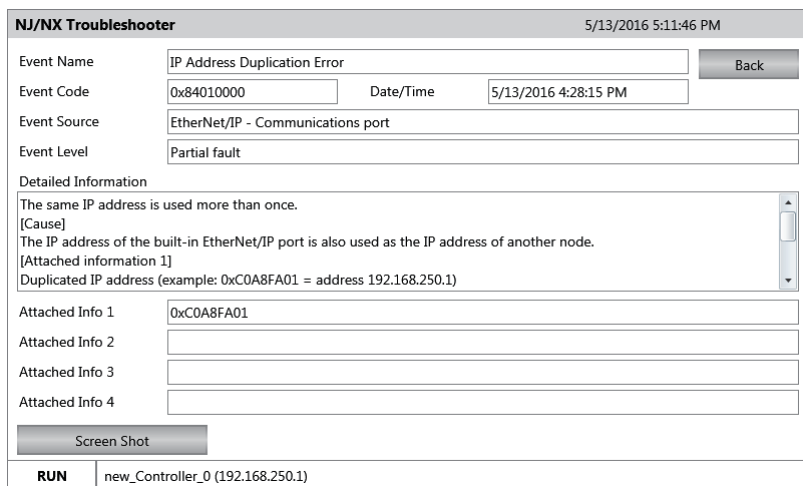

After you complete all of the correction steps for the current errors, click the **Error Reset** Button in the Controller Event List Screen to reset all of the current errors.

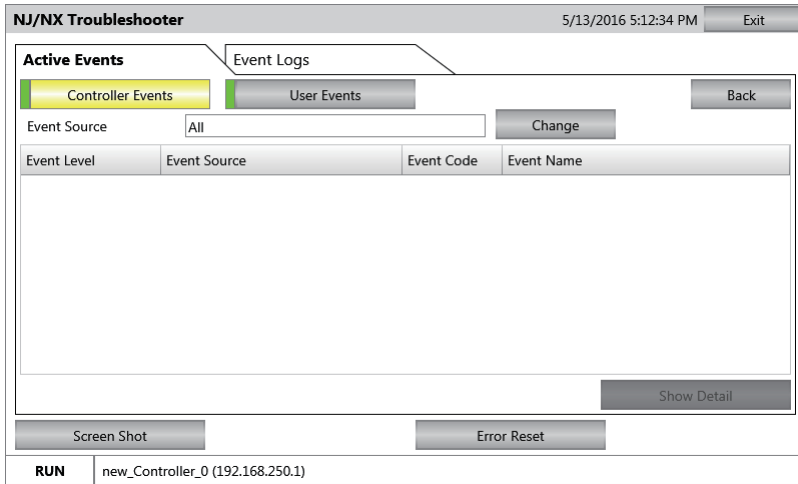

Return to the Controller Status Screen and check the Controller status. The status of the Controller whose errors were completely reset is displayed as “Normal”.

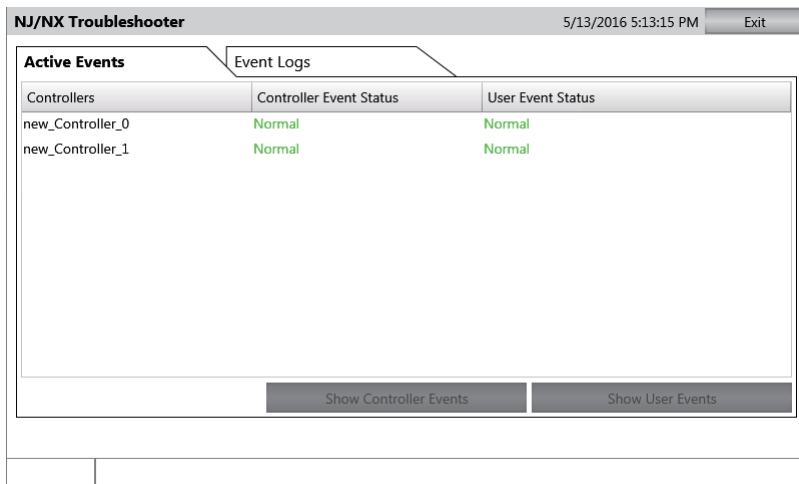

If the cause of the error is not removed, or if the power supply is not cycled or the Controller is not reset as required after resetting the error, the error will occur again.

Refer to the relevant HMI manual for details on the HMI Troubleshooter.

2-3-3 Identifying and Resetting Errors from the User Program

In an NJ/NX-series Controller, you can check for errors that have occurred from the user program. This feature allows you to program operations in the user program according to the error status. Special instructions are provided for this purpose. These include instructions to get Controller error information and instructions to reset Controller errors.

Instructions That Get Controller Error Information

Determine the error status with the instruction to get error information that is provided for each function module. The following table lists the instruction that are used to get error information for each function module.

Instruction name	Instruction	Function
Get PLC Controller Error Status	GetPLCError	Gets the status and the event code of the error with the highest level of the Controller errors in the PLC Function Module.
Get I/O Bus Error Status	GetCJBError	Gets the status and the event code of the error with the highest level of the Controller errors in the I/O bus of the NJ-series CPU Unit.
Get NX Bus Error Status	GetNXBError	Gets the highest level status of the current Controller errors in the NX Bus Function Module of an NX-series CPU Unit.
Get NX Unit Error Status	GetNXUnitError	Gets the highest level status and highest level event code of the current Controller errors in the specified NX bus master or NX Unit in the NX Bus Function Module of an NX-series CPU Unit.
Get Motion Control Error Status	GetMCErr	Gets the status and the event code of the error with the highest level of the Controller errors in the Motion Control Function Module.
Get EtherCAT Error Status	GetECErr	Gets the status and the event code of the error with the highest level of the communications port errors and master errors detected by the EtherCAT Master Function Module.
Get EtherNet/IP Error Status	GetEIPError	Gets the status and the event code of the error with the highest level of the Controller errors in the EtherNet/IP Function Module.

Refer to the *NJ/NX-series Instructions Reference Manual* (Cat. No. W502) for details on these instructions.

Example of Error Detection for the EtherCAT Master Function Module

Name	Data type	Initial value	Comment
Trigger	BOOL	FALSE	Get Condition
EC_Error	BOOL	FALSE	EtherCAT Master Error Flag

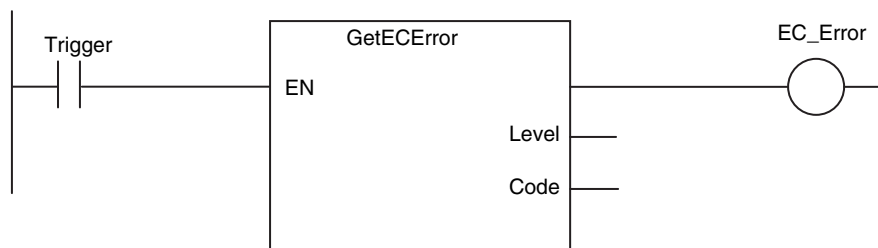

Resetting Controller Errors with Instructions

You can use the instructions that are provided to reset errors in the user program to reset errors that occur in the Controller. Before you attempt to reset a Controller error, isolate and remove the cause of the error. Reset the errors with the instruction provided to reset errors for each function module.

Instruction name	Instruction	Function
Reset PLC Controller Error	ResetPLCError	Resets current Controller errors from the PLC Function Module.
Reset I/O Bus Controller Error	ResetCJBError	Resets current Controller errors from the I/O bus of the NJ-series CPU Unit.
Reset NX Bus Error	ResetNXBError	Resets the current Controller errors in the NX Bus Function Module.
Reset Motion Control Error	ResetMCErr	Resets current Controller errors from the Motion Control Function Module.
Reset EtherCAT Error	ResetECErr	Resets current Controller errors from the EtherCAT Master Function Module.

Refer to the *NJ/NX-series Instructions Reference Manual* (Cat. No. W502) for details on these instructions.

2-3-4 Checking for Errors with System-defined Variables

The system-defined variables include an Error Status variable, which shows the error status in a hierarchical structure. The system determines the error status of each level by logically ORing the error status information of the next lower level. You can read the Error Status variable from an external device through communications. Refer to the *NJ/NX-series CPU Unit Software User's Manual* (Cat. No. W501) for information on system-defined variables.

● **NX-series CPU Units**

Level 1 Level 2 Level 3 Level 4

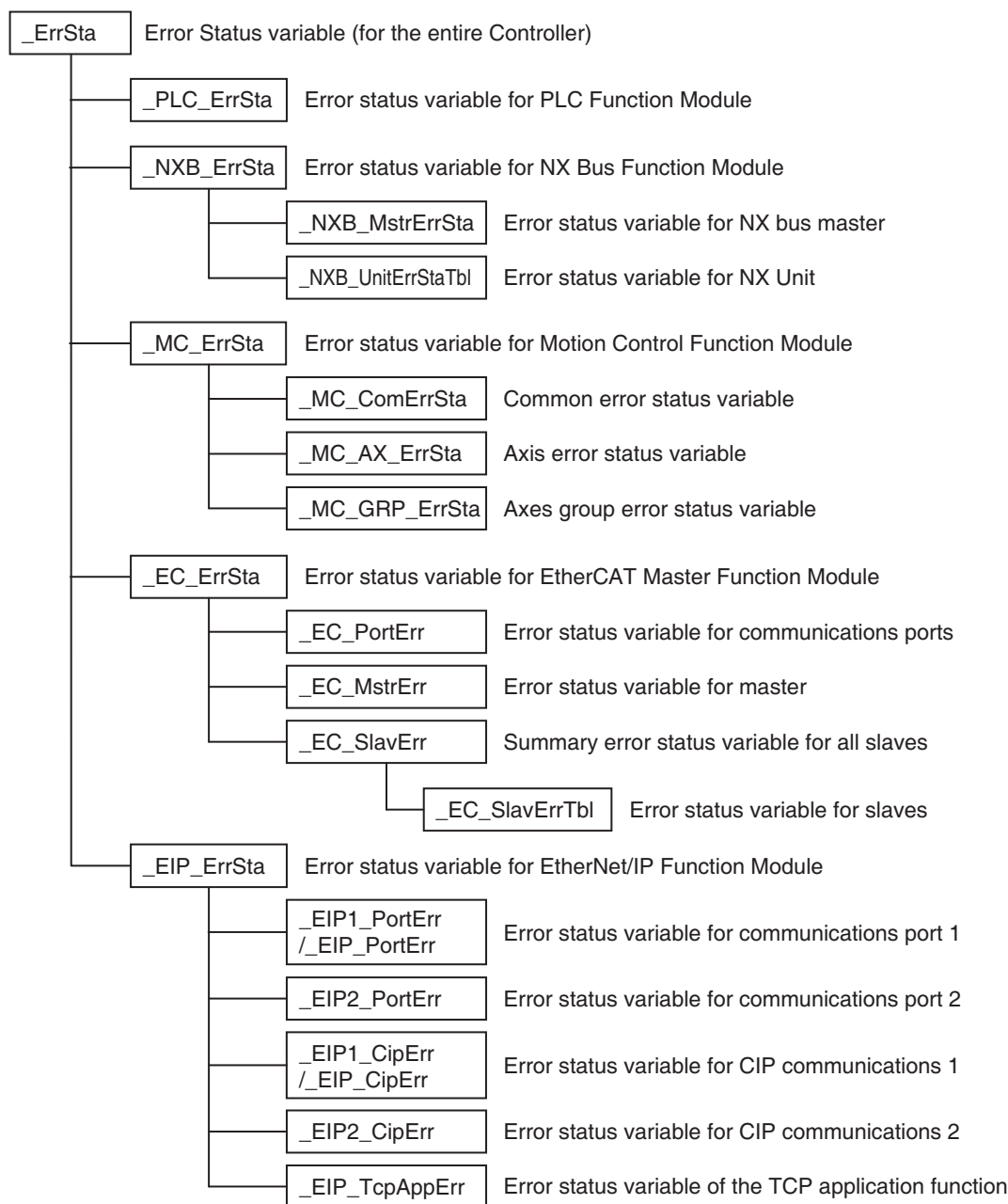

● **NJ-series CPU Units**

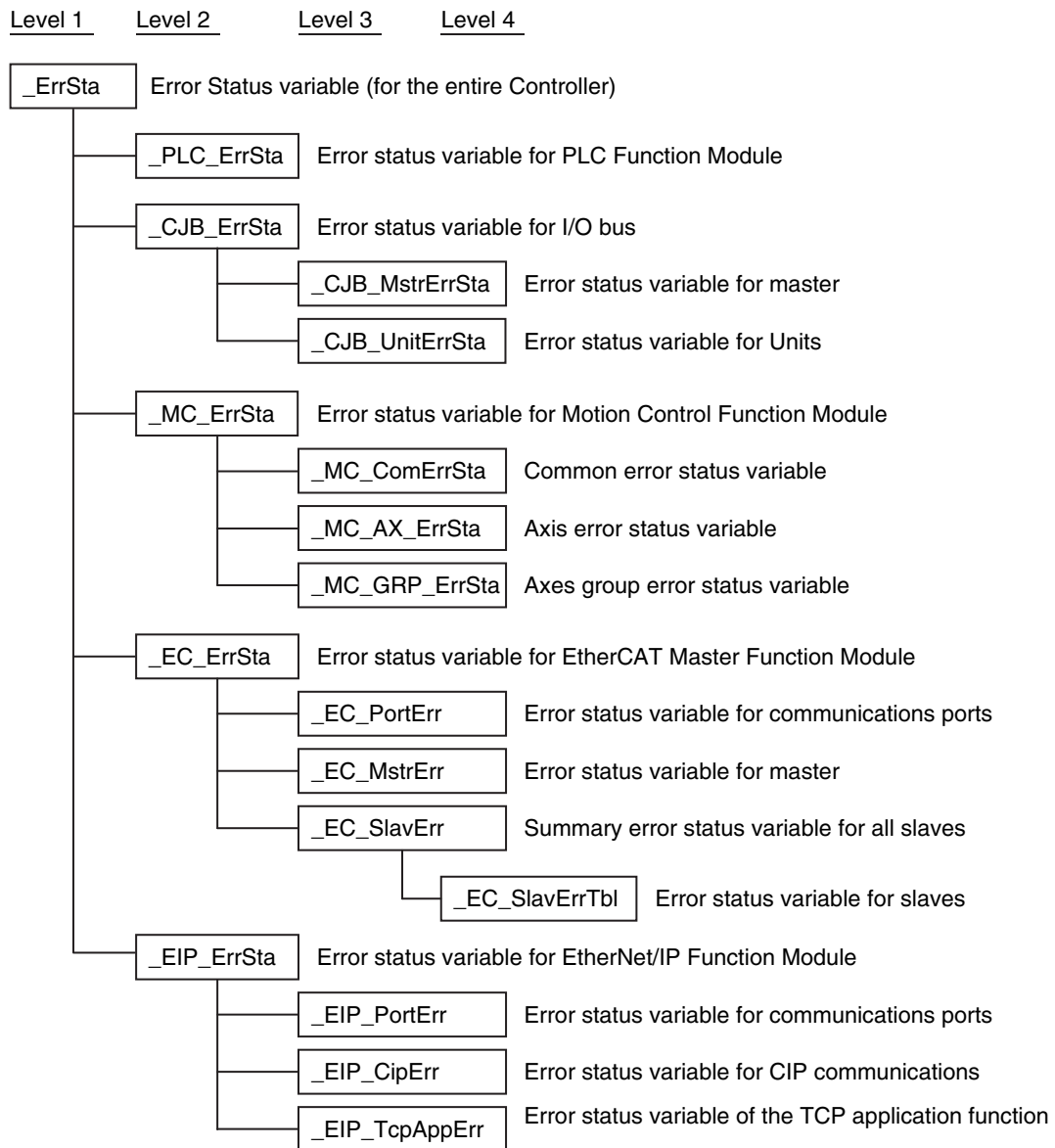

2-4 Troubleshooting When You Cannot Go Online from the Sysmac Studio

The section describes the procedure to troubleshoot when you cannot go online with the CPU Unit from the Sysmac Studio.

2-4-1 Causes and Correction When You Cannot Go Online from the Sysmac Studio

The following table lists the possible causes when you cannot go online with the NJ/NX-series CPU Unit from the Sysmac Studio.

Cause	Description	Correction
Incorrect settings or faulty communications path	There is a mistake in the settings that the Sysmac Studio uses to go online with the CPU Unit. Or, the communications path is faulty.	Refer to <i>Troubleshooting Incorrect Settings and Faulty Communications Path</i> on page 2-20.
Fatal error in the CPU Unit	A fatal error occurred in the CPU Unit.	Refer to 2-1-1 <i>Checking to See If the CPU Unit Is Operating</i> .
High system service load*1	The system service load on the CPU Unit is too high and time cannot be obtained to connect with the Sysmac Studio.	Start in Safe Mode. Refer to <i>Troubleshooting a High System Service Load</i> on page 2-24.

*1 This applies to an NJ-series CPU Unit.

Note If the EtherNet/IP NET ERR indicator on the CPU Unit is lit or flashing, it is possible that you cannot go online through an EtherNet/IP route because of an error in the EtherNet/IP Function Module. If the CPU Unit has a peripheral (USB) port, see if you can go online with a direct USB connection. If the CPU Unit does not have a peripheral (USB) port, see if you can go online with a direct Ethernet connection.



Precautions for Correct Use

If you connect an NX-series CPU Unit to the Sysmac Studio through an EtherNet/IP port, connect to communications port 1. You cannot connect the Sysmac Studio directly to communications port 2.

You can use the status of the RUN indicator on the CPU Unit to isolate the cause. Implement the troubleshooting for the applicable cause.

RUN indicator	Causes		
	Incorrect settings or faulty communications path	Fatal error in the CPU Unit	High system service load
No lit.	Cause	Cause	---
Flashing*1 at 2-s intervals.	---	Cause*2	---
Flashing*3 at 3-s intervals.	---	Cause (Incorrect Power Supply Unit connected.)	---
Lit.	Cause	---	Cause

- *1 This applies to an NX-series CPU Unit.
- *2 If the ERROR indicator is lit at the same time or if the RUN indicator flashes at a 2-second interval for more than 30 seconds, a fatal CPU Unit error has occurred.
- *3 This applies to an NJ-series CPU Unit.

2-4-2 Troubleshooting for Each Cause

This section provides troubleshooting methods for incorrect settings, fault communications paths, and high system service loads.

Troubleshooting Incorrect Settings and Faulty Communications Path

If the Sysmac Studio cannot go online with the CPU Unit, troubleshoot the problem with the following flowchart.

● Direct Connection to Peripheral USB Port

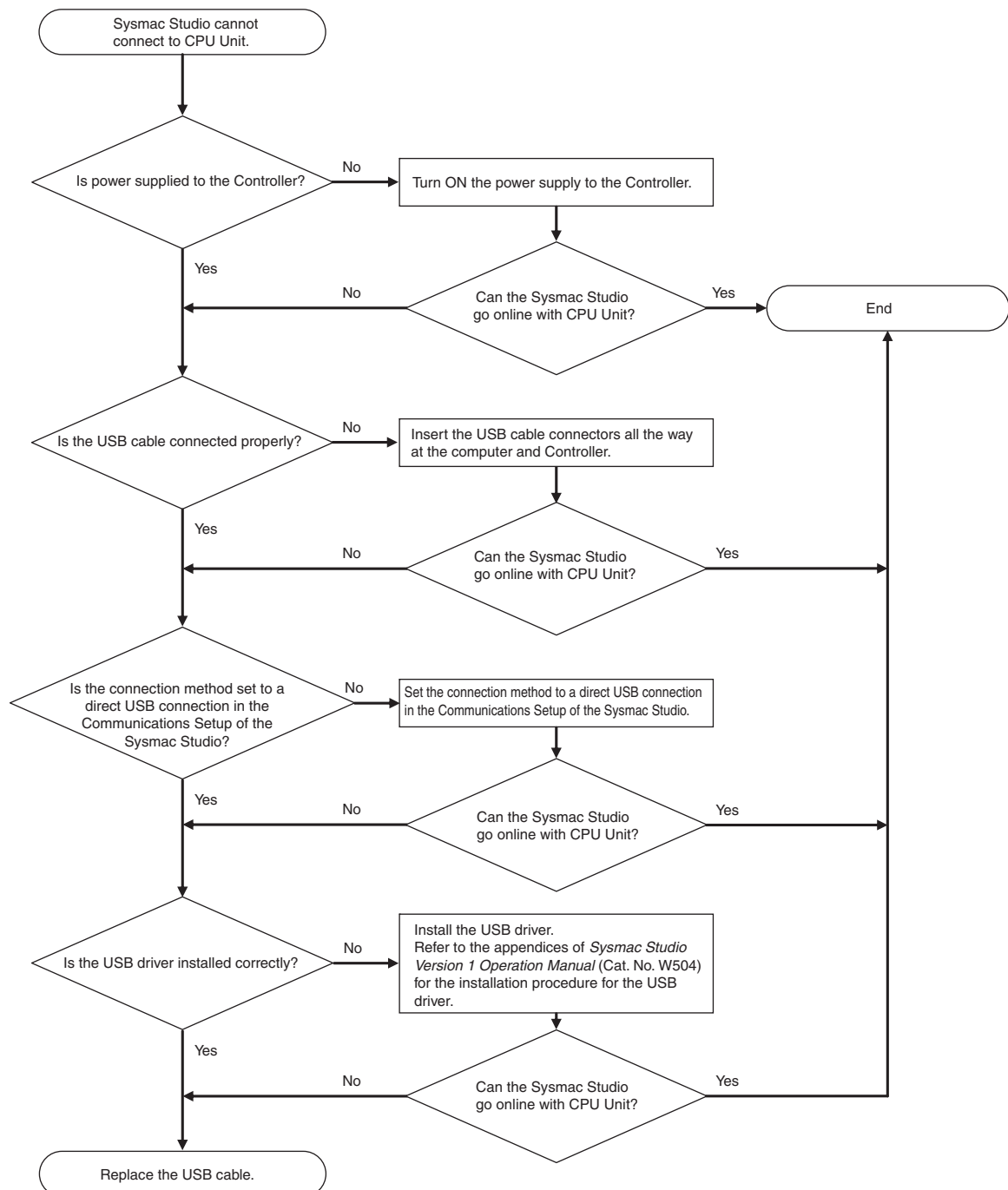

● Remote Connection to Peripheral USB Port

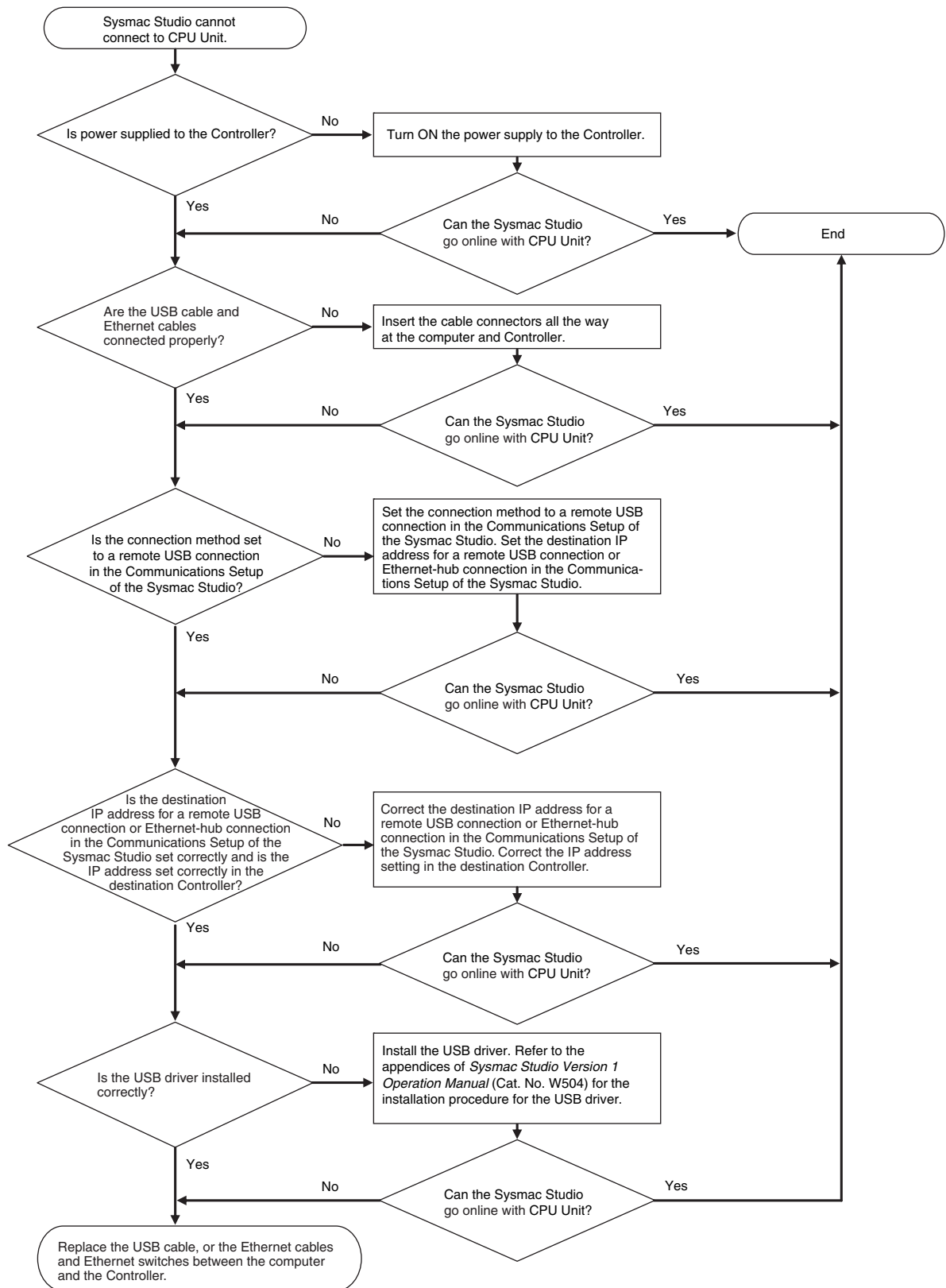

● Direct Connection with EtherNet/IP Port

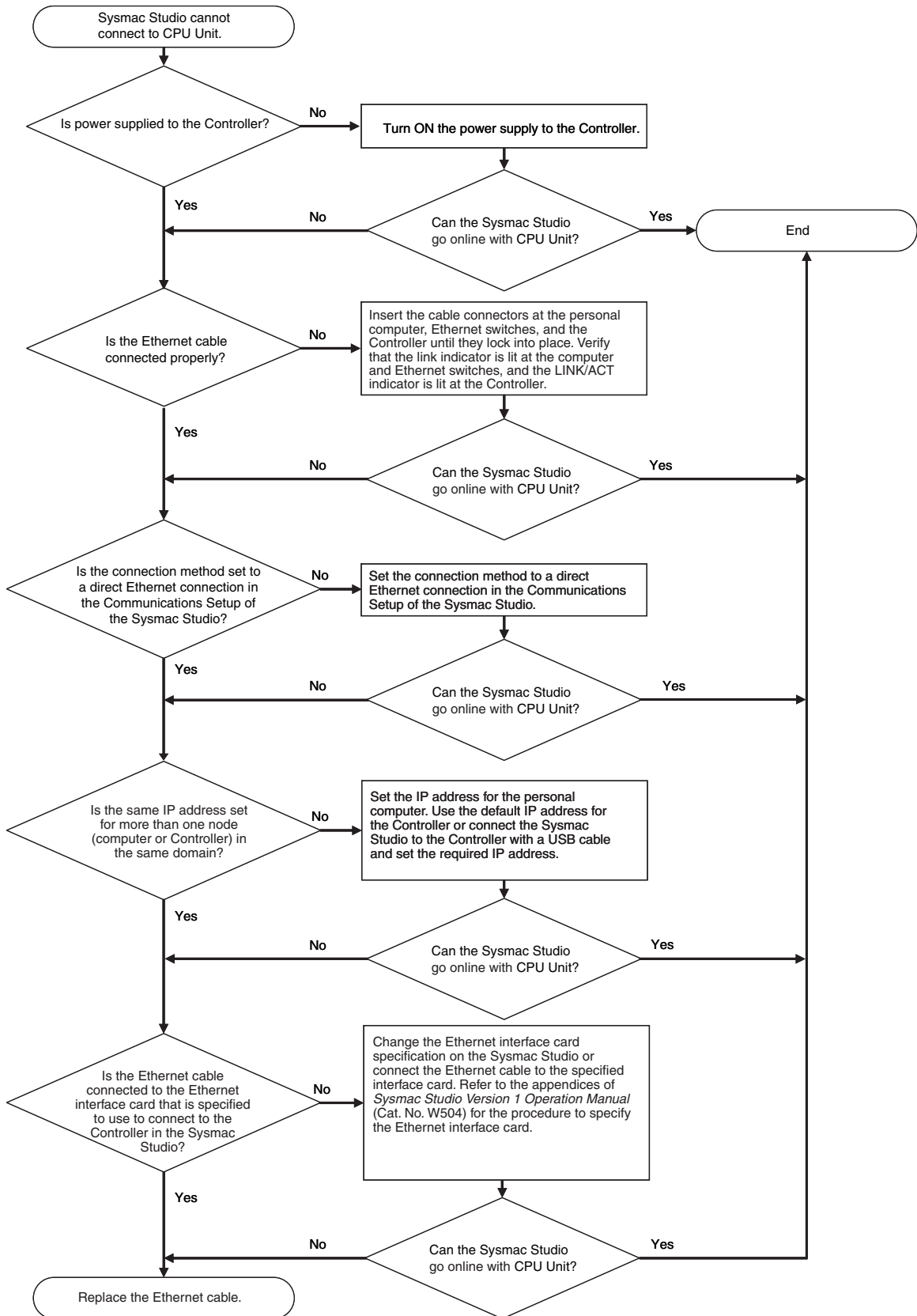

● Ethernet Hub Connection

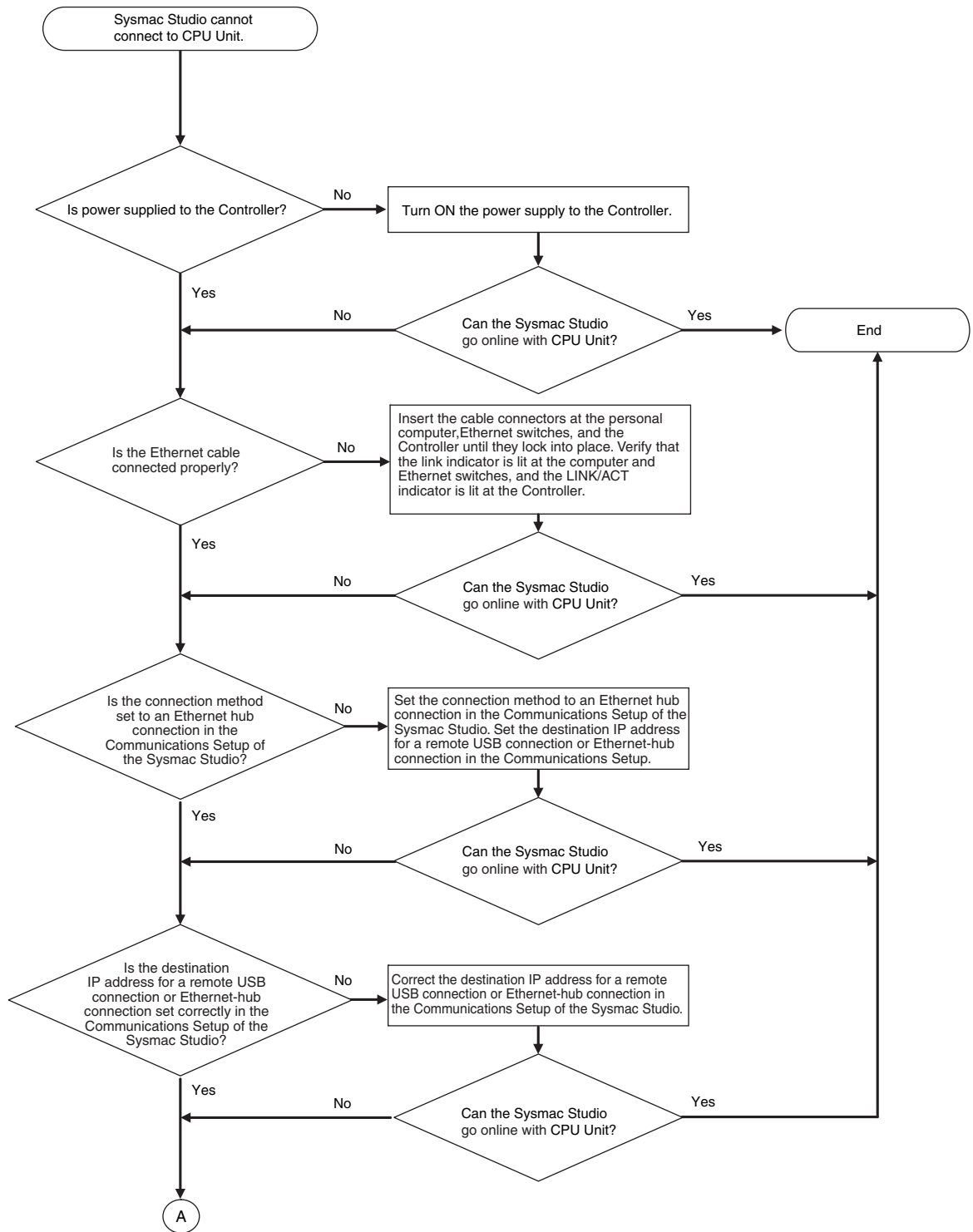

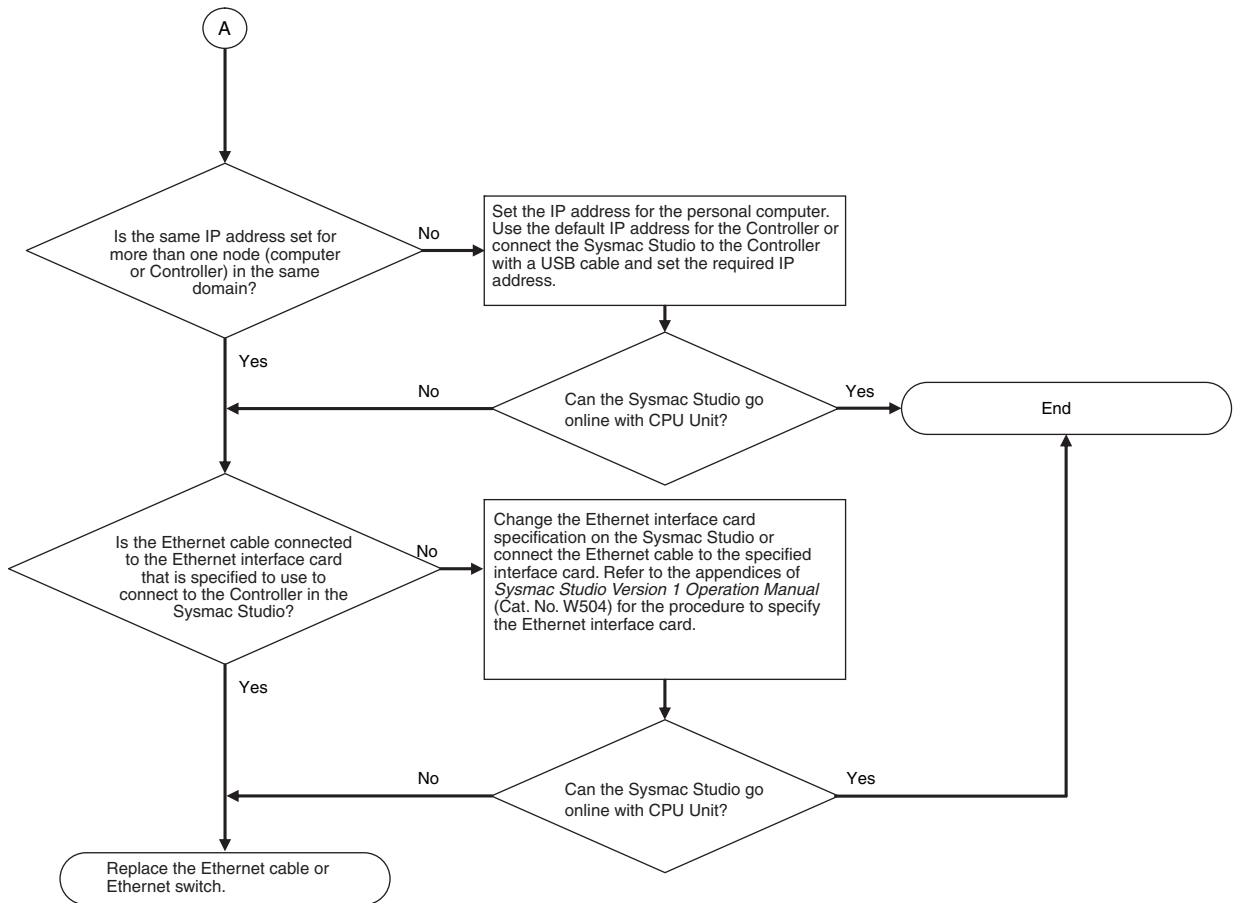

Troubleshooting a High System Service Load

In the NJ-series CPU Unit, a high throughput in task execution may cause the system service to enter a high-load state, and this may prevent the Sysmac Studio from connecting with the CPU Unit.

If a high system service load is the problem, you will be able to go online with the CPU Unit from the Sysmac Studio if you start in Safe Mode. Use the following procedure.

- 1** Set on the DIP switch on the CPU Unit as shown below and then cycle the power supply to the Controller.

The CPU Unit will start in Safe Mode.

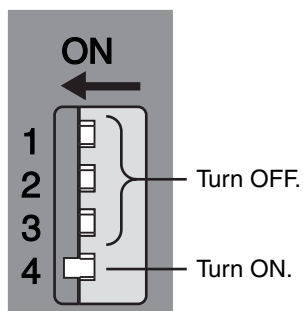

- 2** Go online with the CPU Unit from the Sysmac Studio and perform the required operation.

Ensure that there is sufficient system service time to enable the Sysmac Studio to go online with the CPU Unit. To do so, either increase the period of the primary periodic task or decrease the sizes of the programs in the primary periodic task. Refer to *NJ/NX-series CPU Unit Software User's Manual* (Cat. No. W501) for information on setting the primary periodic task.

- 3 Turn OFF all DIP switch pins and then cycle the power supply to the Controller to restore normal CPU Unit operation.

● Safe Mode Operation

If the Controller is started when the CPU Unit is in Safe Mode, the CPU Unit will start in PROGRAM mode even if the startup mode is set to RUN mode. This increases the ratio of system service processing that is performed by the CPU Unit, which makes it easier for the Sysmac Studio to go online with the CPU Unit. You can also use Safe Mode when you do not want to execute the user program. The CPU Unit will generate an observation level Controller event and record a Safe Mode event in the event log.



Additional Information

Operation in Safe Mode depends on the unit version of the CPU Unit.

Item	Unit version of CPU Unit	
	1.02 or lower	1.03 or later
Operating mode	The CPU Unit operates according to the setting of the startup mode.	The CPU Unit ignores the setting of the startup mode and operates in PROGRAM mode.
Changing the operating mode	Not possible.	Possible.
Controller event level	Major fault level	Observation level

3

Error Tables

This section lists all of the errors (events) that can occur on NJ/NX-series Controllers.

3-1	Errors by Source	3-2
3-1-1	Interpreting Error Descriptions	3-2
3-1-2	Errors in the PLC Function Module	3-2
3-1-3	Errors in the NX Bus Function Module	3-61
3-1-4	Errors in the Motion Control Function Module	3-64
3-1-5	Errors in the EtherNet/IP Function Module	3-95
3-1-6	Errors in the EtherCAT Master Function Module	3-99
3-1-7	Errors in OPC UA	3-104
3-1-8	Errors in the DB Connection Service Function	3-108
3-1-9	Errors in GEM Services	3-114
3-1-10	Errors in Robot Control Function	3-119
3-1-11	Errors in CNC Function	3-134
3-1-12	Errors in Slave Terminals	3-150
3-1-13	Errors in EtherCAT Slaves	3-190
3-1-14	Errors in CJ-series Units	3-223
3-2	An Error Log Table for CJ-series Special Units	3-243
3-3	Events in Order of Event Codes	3-248
3-3-1	Interpreting Error Descriptions	3-248
3-3-2	Error Table	3-249
3-4	Instruction Error Table	3-296

3-1 Errors by Source

This section provides tables of errors (events) by source. Within each source, errors are given by functional classifications. Events that are not errors are also given in the tables.

3-1-1 Interpreting Error Descriptions

The contents of the error tables are described below.

Item	Description
Event code	The event code of the error in the NJ/NX-series Controller is given. The codes are given in eight hexadecimal digits.
Event name	The name of the error is given
Meaning	A short description of the error is given.
Assumed cause	The assumed cause of the error is given
Level	The level of influence on control is given. The abbreviations have the following meanings. Maj: Major fault level Prt: Partial fault level Min: Minor fault level Obs: Observation Info: Information The symbols have the following meanings. S: Event levels that are defined by the system. U: Event levels that can be changed by the user. (See note.)
Reference	The catalog number of the manual that provides details on the event is given. The manual name that corresponds to the manual number is given before each error table.

Note This symbol appears only for events for which the user can change the event level.

3-1-2 Errors in the PLC Function Module

The section provides tables of the errors (events) that can occur in the PLC Function Module. They are divided into the following functional classifications.

- Self-diagnosis
- CJ-series Unit configuration
- Built-in I/O, Option Boards
- Tasks
- Controller operation
- FINS communications
- Instructions



Additional Information

- Instruction events are supported by CPU Units with unit version 1.02 or later.
- To create instruction events, you must select *Use for Event Log Settings – Instruction Error Output* on the Controller Setup. With the default setting, instructions events are not output. Sysmac Studio version 1.03 or higher is required to use the Event Log Settings.

Errors for Self Diagnosis

The manual names are given below for the catalog numbers given in the *Reference* column of the event table.

Cat. No.	Manual name
W500	NJ-series CPU Unit Hardware User's Manual
W535	NX-series CPU Unit Hardware User's Manual
W578	NX-series NX1P2 CPU Unit Hardware User's Manual

Event code	Event name	Meaning	Assumed cause	Level					Reference
				Maj	Prt	Min	Obs	Info	
00090000 hex	DIP Switch Setting Error	An error was detected in the DIP switch setting.	<ul style="list-style-type: none"> There is an error in the DIP switch setting. 	S					W500, W535, W578
000D0000 hex	Internal NJ-series Bus Check Error	A fatal error was detected on the internal bus.	<ul style="list-style-type: none"> Conductive material has gotten inside. Noise The CPU Unit has failed. 	S					W500, W535, W578
000E0000 hex	Non-volatile Memory Life Exceeded	The specified number of deletions for non-volatile memory was exceeded. Or, the number of bad blocks in memory exceeded the specified value.	<ul style="list-style-type: none"> Non-volatile memory life expired. 	S					W500, W535, W578
00110000 hex (Ver. 1.10 or later)	CPU Unit Overheat (Operation Stopped)	Operation was stopped because the temperature inside the CPU Unit was too high.	<ul style="list-style-type: none"> The ambient operating temperature is too high. 	S					W535
00130000 hex (Ver. 1.13 or later)	Main Memory Check Error	An error was detected in the memory check of the main memory in the CPU Unit.	<ul style="list-style-type: none"> A conductive material has gotten inside. Noise There is a software error. The CPU Unit has failed. 	S					W535, W578
10010000 hex	Non-volatile Memory Restored or Formatted	An error was detected in the non-volatile memory check and file system recovery or formatting was executed. Previous files may have been deleted.	<ul style="list-style-type: none"> The Controller power supply was turned OFF while the BUSY indicator was lit. The power supply to the Controller was interrupted momentarily while the BUSY indicator was lit. 	S					W500, W535, W578
10020000 hex	Non-volatile Memory Data Corrupted	A file that must be in non-volatile memory is missing or corrupted.	<ul style="list-style-type: none"> The Controller power supply was turned OFF while the BUSY indicator was lit. The power supply to the Controller was interrupted momentarily while the BUSY indicator was lit. The CPU Unit has failed. 	S					W500, W535, W578
10080000 hex	Main Memory Check Error	An error was detected in the memory check of the main memory in the CPU Unit.	<ul style="list-style-type: none"> Conductive material has gotten inside. Noise There is a software error. The CPU Unit has failed. 	S					W500, W535, W578

Event code	Event name	Meaning	Assumed cause	Level					Reference
				Maj	Prt	Min	Obs	Info	
100A0000 hex (Ver. 1.10 or later)	Data Not Saved to Battery-backup Memory	An error occurred in the software and data could not be saved in battery-backup memory during power-OFF processing.	<ul style="list-style-type: none"> An error occurred in the software. 	S					W500, W535
100B0000 hex	Non-volatile Memory Data Corrupted	A file that must be in non-volatile memory is missing or corrupted.	<ul style="list-style-type: none"> The Controller power supply was turned OFF while the BUSY indicator was lit. The power supply to the Controller was interrupted momentarily while the BUSY indicator was lit. The CPU Unit has failed. 	S					W500, W535, W578
100C0000 hex (Ver. 1.03 or later)	Event Level Setting Error	The settings in the event level setting file are not correct.	<ul style="list-style-type: none"> The event level settings are not correct because the power supply to the Controller was interrupted or communications with the Sysmac Studio were disconnected during a download of the event level settings. The event level settings are not correct because the power supply to the Controller was interrupted during a Clear All Memory operation. Non-volatile memory failed. 	S					W500, W535, W578
100F0000 hex (Ver. 1.13 or later)	Present Values of Retained Variables Restoration Error	An error occurred in the software and the present values of retained variables could not be restored at startup. The values were initialized.	<ul style="list-style-type: none"> An error occurred in the software. 	S					W578
10100000 hex (Ver. 1.13 or later)	Present Values of Retained Variables Not Saved	A forced shutdown is performed or an error occurred in the software and the present values of retained variables could not be saved during power-OFF processing.	<ul style="list-style-type: none"> A forced shutdown is performed. (NY-series Controllers) An error occurred in the software. 	S					W578
40010000 hex	PLC System Processing Error	A fatal error was detected in the PLC Function Module.	<ul style="list-style-type: none"> An error occurred in the software. 	S					W500
40020000 hex	PLC System Processing Error	A fatal error was detected in the PLC Function Module.	<ul style="list-style-type: none"> An error occurred in the software. 	S					W500, W535, W578
40030000 hex	PLC System Processing Error	A fatal error was detected in the PLC Function Module.	<ul style="list-style-type: none"> An error occurred in the software. 	S					W500, W535, W578
40040000 hex (Ver. 1.10 or later)	PLC System Processing Error	A fatal error was detected in the PLC Function Module.	<ul style="list-style-type: none"> An error occurred in the software. 	S					W535, W578
40050000 hex (Ver. 1.10 or later)	PLC System Processing Error	A fatal error was detected in the PLC Function Module.	<ul style="list-style-type: none"> An error occurred in the software. 	S					W535, W578

Event code	Event name	Meaning	Assumed cause	Level					Reference
				Maj	Prt	Min	Obs	Info	
00070000 hex	Real-Time Clock Stopped	The oscillation of the real-time clock stopped. The real-time clock is set to an illegal time.	<ul style="list-style-type: none"> The battery voltage is low. The battery connector has come loose. The Battery is missing. 			S	U		W500, W535, W578
00080000 hex	Real-Time Clock Failed	The real-time clock in the CPU Unit failed.	<ul style="list-style-type: none"> The CPU Unit clock has failed. 			S			W500, W535, W578
000B0000 hex	Low Battery Voltage	The voltage of the Battery has dropped.	<ul style="list-style-type: none"> The battery voltage is low. The battery connector has come loose. The Battery is missing. 			S	U		W500, W535, W578
000C0000 hex	CPU Unit Overheat	The temperature inside the CPU Unit exceeded the specified value.	<ul style="list-style-type: none"> The ambient operating temperature is too high. 			S			W500, W535, W578
00120000 hex (Ver. 1.10 or later)	Slow Fan	The speed of the fan dropped to a specified level or lower.	<ul style="list-style-type: none"> Something is interfering with fan operation, such as dust, wire scraps, or cuttings. The fan has reached the end of its service life. The fan is faulty. 			S	U		W535
10090000 hex	Battery-backup Memory Check Error	An error was detected in the memory check of the battery-backup memory in the CPU Unit.	<ul style="list-style-type: none"> The battery voltage is low. The battery connector has come loose. The Battery is missing. 			S	U		W500, W535
000F0000 hex	SD Memory Card Invalid Type	The current SD Memory Card is not supported.	<ul style="list-style-type: none"> An SD Memory Card that is not supported was inserted into the CPU Unit. 				S		W500, W535, W578
00100000 hex	SD Memory Card Life Exceeded	The specified number of deletions for the SD Memory Card was exceeded. Or, the number of bad blocks exceeded the specified value.	<ul style="list-style-type: none"> The service life of the SD Memory Card was exceeded. 			U	S		W500, W535, W578
10030000 hex	SD Memory Card Invalid Format	The file format of the SD Memory Card is not FAT16 or FAT32.	<ul style="list-style-type: none"> The file format of the SD Memory Card inserted in the CPU Unit is not FAT16 or FAT32. 				S		W500, W535, W578
10040000 hex	SD Memory Card Restored or Formatted	An error was detected during the file system check and the file system was restored. Files may have been deleted.	<ul style="list-style-type: none"> The Controller power supply was turned OFF while the SD BUSY indicator was lit. The power supply to the Controller was interrupted momentarily while the SD BUSY indicator was lit. The SD Memory Card was removed while the SD PWR indicator was lit. The SD Memory Card is damaged. 			U	S		W500, W535, W578

Event code	Event name	Meaning	Assumed cause	Level					Reference
				Maj	Prt	Min	Obs	Info	
10060000 hex	SD Memory Card Data Corrupted	A file that must be in the SD Memory Card is missing or corrupted.	<ul style="list-style-type: none"> The Controller power supply was turned OFF while the SD BUSY indicator was lit. The power supply to the Controller was interrupted momentarily while the SD BUSY indicator was lit. The SD Memory Card was removed while the SD PWR indicator was lit. The SD Memory Card is damaged. 			U	S		W500, W535, W578
10070000 hex	SD Memory Card Access Power OFF Error	The power supply to the Controller was interrupted during access to the SD Memory Card.	<ul style="list-style-type: none"> The Controller power supply was turned OFF while the SD BUSY indicator was lit. The power supply to the Controller was interrupted momentarily while the SD BUSY indicator was lit. 				S		W500, W535, W578
10130000 hex (Ver. 1.13 or later)	PLC System Information	This event provides internal information from the PLC Function Module.	<ul style="list-style-type: none"> This event provides internal information from the PLC Function Module. It is recorded to provide additional information for another event. 				S		W578
10310000 hex (Ver. 1.02 or later)	Incorrect SD Memory Card Removal	SD Memory Card removal processing failed.	<ul style="list-style-type: none"> The SD Memory Card was removed while the SD PWR indicator was lit. 				S		W500, W535, W578

Errors Related to CJ-series Unit Configuration

The manual names are given below for the catalog numbers given in the *Reference* column of the event table.

Cat. No.	Manual name
W500	NJ-series CPU Unit Hardware User's Manual

Event code	Event name	Meaning	Assumed cause	Level					Reference
				Maj	Prt	Min	Obs	Info	
04010000 hex	I/O Bus Check Error	An error occurred in a bus line transmission between the CPU Unit and the Units in the rack slots. Or, detection of all Special I/O Units and CPU Bus Units was not completed when the power supply to the Controller was turned ON.	<ul style="list-style-type: none"> The I/O Connecting Cable is disconnected or wires inside it are broken. Conductive material has gotten inside. The connector contact is faulty due to foreign material in the connector. Noise A Unit has failed. 	S					W500
24010000 hex	Unsupported Unit Detected	An unsupported CJ-series Unit or Power Supply Unit is mounted.	<ul style="list-style-type: none"> An unsupported CJ-series Unit or Power Supply Unit was detected. 	S					W500
24020000 hex	Too Many I/O Points	The total number of I/O points in the connected CJ-series Units exceeds the maximum specified value of the CPU Unit.	<ul style="list-style-type: none"> The total number of I/O points in the connected CJ-series Basic I/O Units exceeds 2,560. 	S					W500
24030000 hex	End Cover Missing	The End Cover is not connected to right end of the CPU Rack or an Expansion Rack.	<ul style="list-style-type: none"> The End Cover is not connected to right end of the CPU Rack or an Expansion Rack. The End Cover is not connected properly. 	S					W500
24040000 hex	Incorrect Unit/Expansion Rack Connection	The number of Units or Expansion Racks exceeds the maximum value specified for the CPU Unit. Or, an Interrupt Input Unit was mounted to a unsupported slot or to an Expansion Rack.	<ul style="list-style-type: none"> More than 10 Units are connected to one Rack. More than three Expansion Racks are connected. More than two Interrupt Input Units are mounted. An Interrupt Input Unit was mounted to a unsupported slot or to an Expansion Rack. 	S					W500
24050000 hex	Duplicate Unit Number	The same unit number is set for more than one Special I/O Unit or more than one CPU Bus Unit.	<ul style="list-style-type: none"> The same unit number is set for more than one Special I/O Unit or more than one CPU Bus Unit. The same unit number is assigned to a Special I/O Unit that uses more than one unit number and another Special I/O Unit. 	S					W500

Event code	Event name	Meaning	Assumed cause	Level					Reference
				Maj	Prt	Min	Obs	Info	
34010000 hex	I/O Setting Check Error	There is an inconsistency between a Unit model in the Unit Configuration in the CPU Unit and the Unit model that is mounted in the Controller.	<ul style="list-style-type: none"> A Unit model or Special Unit unit number in the Unit Configuration in the CPU Unit is different from the Unit model or the Special Unit unit number of the Unit that is mounted in the Controller. 	S					W500
44400000 hex	PLC Function Processing Error	A fatal error was detected in the PLC Function Module.	<ul style="list-style-type: none"> An error occurred in the software. 	S					W500
64010000 hex	Impossible to Access Special Unit	An error occurred in data exchange between the CPU Unit and a Special Unit.	<ul style="list-style-type: none"> The setting of the rotary switches or a DIP switch pin on a Special Unit is not correct. An error occurred in the Special Unit. The Unit connection is faulty. Noise A Unit has failed. 			S			W500
102D0000 hex (Ver. 1.03 or later)	CJ-series Unit Backup Failed	The backup operation for a CJ-series Unit ended in an error.	<ul style="list-style-type: none"> An error occurred in the Unit Configuration. An error occurred for a Special Unit. A restart is in progress for the Special Unit. A Unit model or Special Unit unit number in the Unit Configuration in the CPU Unit is different from the Unit model or the Special Unit unit number of the Unit that is mounted in the Controller. The CPU Unit or CJ-series Unit has failed. 				S		W500
102E0000 hex (Ver. 1.03 or later)	CJ-series Unit Restore Operation Failed	The restore operation for a CJ-series Unit ended in an error.	<ul style="list-style-type: none"> An error occurred in the Unit Configuration. An error occurred for a Special Unit. The Unit Configuration in the backup file does not agree with the physical Unit configuration. A restart is in progress for the Special Unit. The restore conditions that are required by the Special Unit are not met. The backup files are corrupted. The CPU Unit or CJ-series Unit has failed. 				S		W500
30200000 hex (Ver. 1.02 or later)	Unsupported Unit Setting	A setting in the Special Unit is not supported.	<ul style="list-style-type: none"> A setting in the Special Unit is not supported by the CPU Unit. 				S		W500
80010000 hex	Illegal Packet Discarded	An illegal packet was received during message communications. The illegal packet was discarded.	<ul style="list-style-type: none"> Noise 				S		W500

Event code	Event name	Meaning	Assumed cause	Level					Reference
				Maj	Prt	Min	Obs	Info	
04020000 hex	PLC System Information	This event provides internal information from the PLC Function Module.	<ul style="list-style-type: none"> This event provides internal information from the PLC Function Module. It is recorded to provide additional information for another event. 					S	W500
44410000 hex	PLC System Information	This event provides internal information from the PLC Function Module.	<ul style="list-style-type: none"> This event provides internal information from the PLC Function Module. It is recorded to provide additional information for another event. 					S	W500

Errors Related to the Built-in I/O and Option Boards

The manual names are given below for the catalog numbers given in the *Reference* column of the event table.

Cat. No.	Manual name
W579	NX-series NX1P2 CPU Unit Built-in I/O and Option Board User's Manual

Event code	Event name	Meaning	Assumed cause	Level					Reference
				Maj	Prt	Min	Obs	Info	
05440000 hex (Ver. 1.13 or later)	Option Board Error	An Option Board was removed or mounted during operation, or an Option Board hardware error occurred.	<ul style="list-style-type: none"> An Option Board was removed or mounted during operation. A hardware error was detected in an Option Board. 			S			W579
35940000 hex (Ver. 1.13 or later)	Option Board Configuration Verification Error	The Option Board configuration setup does not agree with the actual configuration.	<ul style="list-style-type: none"> The Option Board configuration setup does not agree with the actual configuration. An Option Board is not mounted correctly. 			S			W579
35950000 hex (Ver. 1.13 or later)	Unsupported Option Board Mounted	There is an unsupported Option Board in the actual configuration.	<ul style="list-style-type: none"> There is an unsupported Option Board in the actual configuration. 			S			W579
88130000 hex (Ver. 1.13 or later)	Analog Option Board Startup Error	An error occurred when an Analog Option Board is started.	<ul style="list-style-type: none"> An Analog Option Board is not mounted correctly. Or an Analog Option Board failed. 			S			W579
88140000 hex (Ver. 1.13 or later)	Analog Option Board Communications Error	A communications error occurred during Analog Option Board operation.	<ul style="list-style-type: none"> If the indicator on an Analog Option Board flashes, it means that an error occurred in communicating with the Analog Option Board during operation. If the indicator on an Analog Option Board is lit, it means that a WDT error occurred in the Analog Option Board. 			S			W579

Errors Related to Tasks

The manual names are given below for the catalog numbers given in the *Reference* column of the event table.

Cat. No.	Manual name
W501	NJ/NX-series CPU Unit Software User's Manual

Event code	Event name	Meaning	Assumed cause	Level					Reference
				Maj	Prt	Min	Obs	Info	
60020000 hex	Task Execution Timeout	Task execution exceeded the timeout detection time.	<ul style="list-style-type: none"> The timeout detection time setting is too short. The task period setting is too short. A user program is too large. The number of times that processing is repeated is larger than expected. Task Priority Error Frequent Event Task Execution 	S					W501
60030000 hex	I/O Refreshing Timeout Error	Consecutive I/O refresh failures occurred during the primary periodic task or periodic task period.	<ul style="list-style-type: none"> The task period setting is too short. Task Priority Error for Periodic Tasks and Event Tasks There are too many Units and slaves that perform I/O refresh in the task period. Frequent Event Task Execution 	S					W501
60040000 hex	Insufficient System Service Time Error	The specified system service execution time could not be obtained.	<ul style="list-style-type: none"> There was not sufficient time to execute the tasks and tag data link service. The system service execution interval is too short or the system service execution time ratio is too long in the System Service Monitoring Settings. 	S					W501
60010000 hex	Task Period Exceeded	Task execution was not completed during the set task period for the primary periodic task or a periodic task.	<ul style="list-style-type: none"> The task period setting is too short. A user program is too large. The number of times that processing is repeated is larger than expected. Task Priority Error for Periodic Tasks and Event Tasks Frequent Event Task Execution 			S			W501
60050000 hex	Task Period Exceeded	Task execution was not completed during the set task period for the primary periodic task or fixed periodic task.	<ul style="list-style-type: none"> The task period setting is too short. A user program is too large. The number of times that processing is repeated is larger than expected. Task Priority Error for Periodic Tasks and Event Tasks Frequent Event Task Execution 				S		W501

Errors Related to Controller Operation

The manual names are given below for the catalog numbers given in the *Reference* column of the event table.

Cat. No.	Manual name
W500	NJ-series CPU Unit Hardware User's Manual
W501	NJ/NX-series CPU Unit Software User's Manual
W535	NX-series CPU Unit Hardware User's Manual
W578	NX-series NX1P2 CPU Unit Hardware User's Manual

Event code	Event name	Meaning	Assumed cause	Level					Reference
				Maj	Prt	Min	Obs	Info	
10200000 hex	User Program/Controller Configurations and Setup Transfer Error	The user program or Controller Configurations and Setup were not transferred correctly.	<ul style="list-style-type: none"> The user program or Controller Configurations and Setup are not correct because the power supply to the Controller was interrupted during a download of the user program or the Controller Configurations and Setup. The user program or Controller Configurations and Setup are not correct because the power supply to the Controller was interrupted during online editing. The user program or Controller Configurations and Setup are not correct because the power supply to the Controller was interrupted during a Clear All Memory operation. The user program or Controller Configurations and Setup are not correct because the power supply to the Controller was interrupted during a restore operation. Non-volatile memory failed. 	S					W500, W501, W535, W578
10210000 hex	Illegal User Program Execution ID	The user program execution IDs set in the user program and in the CPU Unit do not match.	<ul style="list-style-type: none"> The user program execution IDs set in the user program and in the CPU Unit do not match. A user program execution ID is set in the CPU Unit but not in the user program. 	S					W500, W501, W535, W578
10240000 hex	Illegal User Program	The user program is not correct.	<ul style="list-style-type: none"> There are more than 8 nesting levels for functions or function blocks. 	S					W500, W501, W535, W578
10250000 hex	Illegal User Program/Controller Configurations and Setup	The upper limit of the usable memory was exceeded or the user program or Controller Configurations and Setup is corrupted.	<ul style="list-style-type: none"> The upper limit of the data size was exceeded. The main memory capacity was exceeded. Non-volatile memory is deteriorating or has failed. 	S					W500, W501, W535, W578

Event code	Event name	Meaning	Assumed cause	Level					Reference
				Maj	Prt	Min	Obs	Info	
10270000 hex (Ver. 1.03 or later)	Error in Starting Automatic Transfer	An error was detected in pre-execution checks for automatic transfer.	<ul style="list-style-type: none"> • An SD Memory Card is not inserted. • The SD Memory Card type is not correct. • The format of the SD Memory Card is not correct. • There is no autoload folder on the SD Memory Card. • There are no backup files in the autoload folder on the SD Memory Card. • Either the backup files in the autoload folder on the SD Memory Card are corrupted or required data is not in the backup files on the SD Memory Card. • The unit version of the CPU Unit to which to transfer the files is older than the unit version of the backup files on the SD Memory Card. • The model of the CPU Unit to which to transfer the files is not the same as the model of the CPU Unit of the backup files on the SD Memory Card. • Recovery was executed for the SD Memory Card. • The CPU Unit is write-protected. • The settings in the automatic transfer command file (AutoloadCommand.ini) are not correct. • Reading the data for automatic transfer failed because the SD Memory Card is faulty or not formatted correctly. • The SD Memory Card is damaged. • The database connection service version of the CPU Unit to which to transfer the files is older than the database connection service version of the backup files on the SD Memory Card. • The robot version of the CPU Unit to which to transfer the files is older than the robot version of the backup files on the SD Memory Card. 	S					W500, W501, W535, W578

Event code	Event name	Meaning	Assumed cause	Level					Reference
				Maj	Prt	Min	Obs	Info	
10280000 hex (Ver. 1.03 or later)	Error in Executing Automatic Transfer	The automatic transfer ended in an error.	<ul style="list-style-type: none"> It was not possible to read the data for automatic transfer. The SD Memory Card was removed during an automatic transfer. There are no backup files in the autoloader folder on the SD Memory Card. The backup files in the autoloader folder on the SD Memory Card are corrupted. The SD Memory Card is damaged. 	S					W500, W501, W535, W578

Event code	Event name	Meaning	Assumed cause	Level					Reference
				Maj	Prt	Min	Obs	Info	
10330000 hex (Ver. 1.11 or later)	SD Memory Card Program Transfer Pre-execution Check Error	An error was detected in pre-execution checks for transferring SD Memory Card programs.	<ul style="list-style-type: none"> An SD Memory Card is not inserted. The SD Memory Card type is not correct. The format of the SD Memory Card is not correct. There is no such folder on the SD Memory Card as specified by the <i>_Card1PrgTransferCmd.DirName</i> system-defined variable. There are no backup files in such a folder on the SD Memory Card as specified by the <i>_Card1PrgTransferCmd.DirName</i> system-defined variable. Either the backup files in the folder specified by the <i>_Card1PrgTransferCmd.DirName</i> system-defined variable on the SD Memory Card are corrupted or required data is not in the backup files on the SD Memory Card. The unit version of the CPU Unit to which to transfer the files is older than the unit version of the backup files on the SD Memory Card. The model of the CPU Unit to which to transfer the files is not the same as the model of the CPU Unit of the backup files on the SD Memory Card. The CPU Unit is write-protected. Required files are not set to transfer in the setting of the <i>_Card1PrgTransferCmd</i> system-defined variable. Reading the data for the SD Memory Card program transfer failed because the SD Memory Card is faulty or not formatted correctly. The SD Memory Card is damaged. The database connection service version of the CPU Unit to which to transfer the files is older than the database connection service version of the backup files on the SD Memory Card. The robot version of the CPU Unit to which to transfer the files is older than the robot version of the backup files on the SD Memory Card. 	S					W500, W501, W535, W578

Event code	Event name	Meaning	Assumed cause	Level					Reference
				Maj	Prt	Min	Obs	Info	
10340000 hex (Ver. 1.11 or later)	Error in Executing SD Memory Card Program Transfer	The SD Memory Card program transfer ended in an error.	<ul style="list-style-type: none"> It was not possible to read the data for SD Memory Card program transfers. The SD Memory Card was removed during a SD Memory Card program transfer. There are no backup files in such a folder on the SD Memory Card as specified by the <i>_Card1PrgTransferCmd.DirName</i> system-defined variable. The backup files in such a folder on the SD Memory Card as specified by the <i>_Card1PrgTransferCmd.DirName</i> system-defined variable are corrupted. The SD Memory Card is damaged. 	S					W500, W501, W535, W578
40110000 hex	PLC Function Processing Error	A fatal error was detected in the PLC Function Module.	<ul style="list-style-type: none"> An error occurred in the software. 	S					W500, W501, W535, W578
40160000 hex (Ver. 1.02 or earlier)	Safe Mode	The Controller started in Safe Mode.	<ul style="list-style-type: none"> The power supply was turned ON to the Controller when Safe Mode was set on the DIP switch on the CPU Unit. 	S					W500, W501
44400000 hex	PLC Function Processing Error	A fatal error was detected in the PLC Function Module.	<ul style="list-style-type: none"> An error occurred in the software. 	S					W500
44420000 hex (Ver. 1.05 or later)	PLC Function Processing Error	A fatal error was detected in the PLC Function Module.	<ul style="list-style-type: none"> An error occurred in the software. 	S					W500, W501, W535, W578
40120000 hex	PLC Function Processing Error	A fatal error was detected in the PLC Function Module.	<ul style="list-style-type: none"> An error occurred in the software. 		S				W500, W501, W535, W578
40130000 hex	PLC Function Processing Error	A fatal error was detected in part of the PLC Function Module.	<ul style="list-style-type: none"> An error occurred in the software. 			S			W500, W501, W535, W578
10230000 hex	Event Log Save Error	Saving the event log failed.	<ul style="list-style-type: none"> A low battery voltage prevented retention of memory during a power interruption. (NJ/NX-series) A forced shutdown was performed. (NY-series) Data in the event log area are invalid. (NY-series) Data in the NX Unit event log area are invalid. (NX1P2 CPU Unit) 				S		W500, W501, W535, W578
10260000 hex	Trace Setting Transfer Failure	The power supply was interrupted while transferring the trace settings.	<ul style="list-style-type: none"> The power supply was interrupted while transferring the trace settings. 				S		W500, W501, W535, W578

Event code	Event name	Meaning	Assumed cause	Level					Reference
				Maj	Prt	Min	Obs	Info	
10290000 hex (Ver. 1.03 or later)	Backup Failed to Start	An error was detected in pre-execution checks for a backup operation.	<ul style="list-style-type: none"> An SD Memory Card is not inserted. The SD Memory Card type is not correct. The format of the SD Memory Card is not correct. The SD Memory Card is write protected. The Prohibiting backing up data to the SD Memory Card parameter is set to prohibit backing up data to an SD Memory Card. Another backup operation is in progress. Synchronization, online editing, or the Clear All Memory operation is in progress. The backup was canceled by the user. The online connection with the Sysmac Studio was disconnected. The SD Memory Card is damaged. 				S		W500, W501, W535, W578
102A0000 hex (Ver. 1.03 or later)	Backup Failed	The backup operation ended in an error.	<ul style="list-style-type: none"> The capacity of the SD Memory Card is insufficient. It was not possible to save the data that was specified for backup. The SD Memory Card was removed during a backup operation. Failed to back up Unit or slave. The backup was canceled by the user. Execution of the Save Cam Table instruction or changing the CPU Unit name is in progress. The online connection with the Sysmac Studio was disconnected. It was not possible to save the data that was specified for backup to the computer. The SD Memory Card is damaged. 				S		W500, W501, W535, W578

Event code	Event name	Meaning	Assumed cause	Level					Reference
				Maj	Prt	Min	Obs	Info	
102B0000 hex (Ver. 1.03 or later)	Restore Operation Failed to Start	An error was detected in pre-execution checks for a restore operation.	<ul style="list-style-type: none"> An SD Memory Card is not inserted. The SD Memory Card type is not correct. The format of the SD Memory Card is not correct. There are no backup files on the SD Memory Card. Either the backup files on the SD Memory Card are corrupted or required data is not in the backup files on the SD Memory Card. The unit version of the CPU Unit to which to restore the files is older than the unit version of the backup files on the SD Memory Card. The model of the CPU Unit to which to restore the files is not the same as the model of the CPU Unit of the backup files on the SD Memory Card. Recovery was executed for the SD Memory Card. The CPU Unit is write-protected. The settings in the restore command file (RestoreCommand.ini) are not correct. A backup operation is in progress. Synchronization, online editing, or the Clear All Memory operation is in progress. The online connection with the Sysmac Studio was disconnected. Reading the data for restoration failed because the SD Memory Card is faulty or not formatted correctly. The SD Memory Card is damaged. The database connection service version of the CPU Unit to which to restore the files is older than the database connection service version of the backup files on the SD Memory Card. The robot version of the CPU Unit to which to restore the files is older than the robot version of the backup files on the SD Memory Card. <p>Check the followings for specification with system-defined variables.</p> <ul style="list-style-type: none"> <i>Restore by system-defined variable</i> is set to <i>Do not use</i> in the Controller Setup. 				S		W500, W501, W535, W578

Event code	Event name	Meaning	Assumed cause	Level					Reference
				Maj	Prt	Min	Obs	Info	
			<ul style="list-style-type: none"> • Password of Restore by system-defined variable in the Controller Setup does not agree with the <i>_Card1RestoreCmd.Password</i> system-defined variable. • The DIP switch on the CPU Unit is not set to allow starting the restore of SD Memory Card backups by specification with system-defined variables. • There is no such folder as specified by the system-defined variable. • Required files are not set to transfer in the setting of the system-defined variable. 						
102C0000 hex (Ver. 1.03 or later)	Restore Operation Failed	The restore operation ended in an error.	<ul style="list-style-type: none"> • It was not possible to read the data to restore. • The SD Memory Card was removed during a restore operation. • Failed to restore Unit or slave. • The SD Memory Card is damaged. 				S		W500, W501, W535, W578

Event code	Event name	Meaning	Assumed cause	Level					Reference
				Maj	Prt	Min	Obs	Info	
10320000 hex (Ver. 1.11 or later)	SD Memory Card Program Transfer Failed to Start	An error was detected in pre-start checks for transferring SD Memory Card programs.	<ul style="list-style-type: none"> • <i>Program transfer by system-defined variable</i> is set to <i>Do not use</i> in the Controller Setup. • <i>Password of Program transfer by system-defined variable</i> in the Controller Setup does not agree with the <i>_Card1PrgTransferCmd.Password</i> system-defined variable. • The DIP switch on the CPU Unit is not set to allow starting the SD Memory Card program transfer. • An SD Memory Card is not inserted. • The SD Memory Card type is not correct. • The format of the SD Memory Card is not correct. • There is no such folder on the SD Memory Card as specified by the <i>_Card1PrgTransferCmd.DirName</i> system-defined variable. • There are no backup files in such a folder on the SD Memory Card as specified by the <i>_Card1PrgTransferCmd.DirName</i> system-defined variable. • Either the backup files in the folder specified by the <i>_Card1PrgTransferCmd.DirName</i> system-defined variable on the SD Memory Card are corrupted or required data is not in the backup files on the SD Memory Card. • The unit version of the CPU Unit to which to transfer the files is older than the unit version of the backup files on the SD Memory Card. • The model of the CPU Unit to which to transfer the files is not the same as the model of the CPU Unit of the backup files on the SD Memory Card. • The CPU Unit is write-protected. • Another backup operation is in progress. • Synchronization, online editing, or the Clear All Memory operation is in progress. • Required files are not set to transfer in the setting of the <i>_Card1PrgTransferCmd</i> system-defined variable. • Reading the data for the SD Memory Card program transfer failed because the SD Memory Card is faulty or not formatted correctly. • The SD Memory Card is damaged. • The database connection service version of the CPU Unit to which to transfer the files is older than the database connection service version of the backup files on the SD Memory Card. • The robot version of the CPU Unit to which to transfer the files is older than the robot version of the backup files on the SD Memory Card. 				S		W500, W501, W535, W578

Event code	Event name	Meaning	Assumed cause	Level					Reference
				Maj	Prt	Min	Obs	Info	
103E0000 hex (Version 1.14 or later)	Restore Pre- execution Check Fail- ure	An error was detected in pre-execution checks for specification with system-defined variables for the SD Memory Card restore operation.	<ul style="list-style-type: none"> An SD Memory Card is not inserted. The SD Memory Card type is not correct. The format of the SD Memory Card is not correct. There is no such folder on the SD Memory Card as specified by the <i>_Card1RestoreCmd.DirName</i> system-defined variable. There are no backup files in such a folder on the SD Memory Card as specified by the <i>_Card1RestoreCmd.DirName</i> system-defined variable. Either the backup files in the folder specified by the <i>_Card1RestoreCmd.DirName</i> system-defined variable on the SD Memory Card are corrupted or required data is not in the backup files on the SD Memory Card. The unit version of the CPU Unit to which to transfer the files is older than the unit version of the backup files on the SD Memory Card. The model of the CPU Unit to which to transfer the files is not the same as the model of the CPU Unit of the backup files on the SD Memory Card. The CPU Unit is write-protected. Required files are not set to transfer in the setting of the system-defined variable. Reading the data for the SD Memory Card program transfer failed because the SD Memory Card is faulty or not formatted correctly. The SD Memory Card is damaged. The database connection service version of the CPU Unit to which to transfer the files is older than the database connection service version of the backup files on the SD Memory Card. The robot version of the CPU Unit to which to transfer the files is older than the robot version of the backup files on the SD Memory Card. 				S		W500, W501, W535, W578
40140000 hex	PLC System Information	This event provides internal information from the PLC Function Module.	<ul style="list-style-type: none"> This event provides internal information from the PLC Function Module. It is recorded to provide additional information for another event. 				S		W500, W501, W535, W578

Event code	Event name	Meaning	Assumed cause	Level					Reference
				Maj	Prt	Min	Obs	Info	
40170000 hex (Ver. 1.03 or later)	Safe Mode	The Controller started in Safe Mode.	<ul style="list-style-type: none"> The Controller started in Safe Mode. 				S		W500, W501, W535, W578
80230000 hex (Ver. 1.05 or later)	NX Message Communications Error	An error has occurred in message communications.	<ul style="list-style-type: none"> The communications cable is broken. The communications cable connector is disconnected. The NX message communications load is high. 				S		W500, W501, W535, W578
40150000 hex	PLC System Information	This event provides internal information from the PLC Function Module.	<ul style="list-style-type: none"> This event provides internal information from the PLC Function Module. It is recorded to provide additional information for another event. 					S	W500, W501, W535, W578
44430000 hex (Ver. 1.05 or later)	PLC System Information	This event provides internal information from the PLC Function Module.	<ul style="list-style-type: none"> This event provides internal information from the PLC Function Module. It is recorded to provide additional information for another event. 					S	W500, W501, W535, W578
90010000 hex	Clock Changed	The clock time was changed.	<ul style="list-style-type: none"> The clock time was changed. 					S	W500, W501, W535, W578
90020000 hex	Time Zone Changed	The time zone was changed.	<ul style="list-style-type: none"> The time zone was changed. 					S	W500, W501, W535, W578
90050000 hex (Ver. 1.10 or later)	User Program/Controller Configurations and Setup Download	The user program and the Controller configurations and setup were downloaded.	<ul style="list-style-type: none"> The user program and the Controller configurations and setup were downloaded. 					S	W500, W501, W535, W578
90070000 hex (Ver. 1.10 or later)	Online Edits Transferred	The user program was edited online.	<ul style="list-style-type: none"> The user program was edited online and the edits were transferred to the Controller. 					S	W500, W501, W535, W578
90080000 hex	Variable Changed to TRUE with Forced Refreshing	Changing a variable to TRUE with forced refreshing was specified.	<ul style="list-style-type: none"> Changing a variable to TRUE with forced refreshing was specified by the user. 					S	W500, W501, W535, W578
90090000 hex	Variable Changed to FALSE with Forced Refreshing	Changing a variable to FALSE with forced refreshing was specified.	<ul style="list-style-type: none"> Changing a variable to FALSE with forced refreshing was specified by the user. 					S	W500, W501, W535, W578
900A0000 hex	All Forced Refreshing Cleared	Clearing all forced refreshing values was specified.	<ul style="list-style-type: none"> Clearing all forced refreshing values was specified by the user. 					S	W500, W501, W535, W578
900B0000 hex	Memory All Cleared	All of memory was cleared.	<ul style="list-style-type: none"> A user with Administrator rights cleared all of the memory. 					S	W500, W501, W535, W578
900C0000 hex	Event Log Cleared	The event log was cleared.	<ul style="list-style-type: none"> The event log was cleared by the user. 					S	W500, W501, W535, W578
900F0000 hex (Ver. 1.03 or later)	Automatic Transfer Completed	The automatic transfer was completed.	<ul style="list-style-type: none"> The automatic transfer was completed. 					S	W500, W501, W535, W578
90110000 hex	Power Turned ON	The power supply was turned ON.	<ul style="list-style-type: none"> The power supply was turned ON. 					S	W500, W501, W535, W578
90120000 hex	Power Interrupted	The power supply was interrupted.	<ul style="list-style-type: none"> The power supply was interrupted. 					S	W500, W501, W535, W578
90130000 hex	Operation Started	Operation was started.	<ul style="list-style-type: none"> A command to start operation was received. 					S	W500, W501, W535, W578
90140000 hex	Operation Stopped	Operation was stopped.	<ul style="list-style-type: none"> A command to stop operation was received. 					S	W500, W501, W535, W578

Event code	Event name	Meaning	Assumed cause	Level					Reference
				Maj	Prt	Min	Obs	Info	
90150000 hex	Reset Executed	A reset was executed.	• A reset command was received.					S	W500, W501, W535, W578
90160000 hex	User Program Execution ID Write	The user program execution ID was set or changed in the CPU Unit.	• A user with Administrator rights changed the user program execution ID that is set in the CPU Unit.					S	W500, W501, W535, W578
90180000 hex	All Controller Errors Cleared	All current errors were cleared.	• The user cleared all current errors.					S	W500, W501, W535, W578
90190000 hex	Forced Refreshing Cleared	Clearing a forced refreshing value was specified.	• Clearing a forced refreshing value was specified by the user.					S	W500, W501, W535, W578
901A0000 hex (Ver. 1.03 or later)	Backup Started	A backup operation was started.	• A backup operation was started.					S	W500, W501, W535, W578
901B0000 hex (Ver. 1.03 or later)	Backup Completed	The backup operation ended normally.	• The backup operation ended normally.					S	W500, W501, W535, W578
901C0000 hex (Ver. 1.03 or later)	Restore Operation Started	A restore operation started.	• A restore operation started.					S	W500, W501, W535, W578
901D0000 hex (Ver. 1.03 or later)	Restore Operation Completed	The restore operation ended normally.	• The restore operation ended normally.					S	W500, W501, W535, W578
90200000 hex (Ver. 1.11 or later)	SD Memory Card Program Transfer Started	Transferring the SD Memory Card programs was started.	• Transferring the SD Memory Card programs was started.					S	W500, W501, W535, W578
90210000 hex (Ver. 1.11 or later)	SD Memory Card Program Transfer Completed	Transferring the SD Memory Card programs was completed.	• Transferring the SD Memory Card programs was completed.					S	W500, W501, W535, W578

Errors Related to FINS Communications

The manual names are given below for the catalog numbers given in the *Reference* column of the event table.

Cat. No.	Manual name
W501	NJ/NX-series CPU Unit Software User's Manual

Event code	Event name	Meaning	Assumed cause	Level					Reference
				Maj	Prt	Min	Obs	Info	
14010000 hex	CPU Bus Unit Setup Area Error	An error was detected in the memory check of the Setup Area for CPU Bus Units.	• The power supply to the Controller was interrupted or communications with the Sysmac Studio were disconnected while downloading the CPU Bus Unit Settings.			S			W501
34100000 hex	IP Address Table Setting Error	The IP address table settings are incorrect.	• The IP address conversion method is set to the combined method or the IP address table method, but the IP address table settings are incorrect.			S			W501

Event code	Event name	Meaning	Assumed cause	Level					Reference
				Maj	Prt	Min	Obs	Info	
34130000 hex	FINS/TCP Connection Table Setting Error	The FINS/TCP connection table is incorrect.	<ul style="list-style-type: none"> The power supply to the Controller was interrupted or communications with the Sysmac Studio were disconnected while downloading the FINS/TCP connection table. 			S			W501
34110000 hex	Unknown Destination Node	The send destination node is not known.	<ul style="list-style-type: none"> The send destination node was not found when a FINS message was sent. 				S		W501
80100000 hex	Packet Discarded	One or more packets were discarded.	<ul style="list-style-type: none"> A FINS response addressed to the CPU Unit was received. The send designation Unit for the FINS response does not exist. 				S		W501
80110000 hex	Packet Discarded	One or more packets were discarded.	<ul style="list-style-type: none"> An attempt was made to send a FINS response with over 2002 bytes. An attempt was made to route a FINS response with over 2002 bytes. Packet was received with a No Such Unit routing error. Packet was received with a Routing Error routing error. Packet was received with a No Routing Table routing error. Packet was received with an Event Area Size Over Limit routing error. There is insufficient space in the internal buffer. FINS message routing failed because the communications load is too high. 				S		W501

Event code	Event name	Meaning	Assumed cause	Level					Reference
				Maj	Prt	Min	Obs	Info	
80120000 hex	Packet Discarded	One or more packets were discarded.	<ul style="list-style-type: none"> • A FINS response was received with the destination network address (DNA) set to the local network and the destination node address (DA1) not set to the local node. • A FINS command or response was received with a hub network address specification for which the destination network address (DNA) was greater than or equal to 80 hex. • There is insufficient space in the internal buffer. • A FINS command that does not have the minimum command length was received. • A FINS command that exceeded the maximum command length was received. • Sending packets failed. • FINS message routing failed because the communications load is too high. Or a command that was addressed to the built-in EtherNet/IP port was received with the source network address (SNA) set to 0. • A FINS response that was addressed to the built-in EtherNet/IP port was received. • A FINS response or a command for which a response is not required was received when the routing tables were not registered. • A FINS response or a command for which a response is not required was received when there was an error in the routing tables. • A FINS response or a command for which a response is not required was received that exceeded the number of relay points. • Transmission is not possible because the destination address is not set in the routing tables. • Routing is not possible because the FINS node address setting in the Built-in EtherNet/IP Port Settings is set to 0 or 255. 				S		W501

Instructions

A version in parentheses in the *Event code* column is the unit version of the CPU Unit when the event code was added.

Event codes for instructions are supported by CPU Units with unit version 1.02 or later.

The manual names are given below for the catalog numbers given in the *Reference* column of the event table.

Cat. No.	Manual name
W502	NJ/NX-series Instructions Reference Manual

Event code	Event name	Meaning	Assumed cause	Level					Reference
				Maj	Prt	Min	Obs	Info	
54010400 hex	Input Value Out of Range	An input parameter for an instruction exceeded the valid range for an input variable. Or, division by an integer of 0 occurred in division or remainder calculations.	<ul style="list-style-type: none"> An input parameter for an instruction exceeded the valid range for an input variable. Or, division by an integer of 0 occurred in division or remainder calculations. 				S		W502
54010401 hex	Input Mismatch	The relationship for the instruction input parameters did not meet required conditions. Or, a numeric value during or after instruction execution did not meet conditions.	<ul style="list-style-type: none"> The relationship for an input parameter did not meet required conditions. A value when processing an instruction or in the result does not meet the conditions. 				S		W502
54010402 hex	Floating-point Error	Non-numeric data was input for a floating-point number input parameter to an instruction.	<ul style="list-style-type: none"> Non-numeric data was input for a floating-point number input parameter to an instruction. 				S		W502
54010403 hex	BCD Error	A value that was not BCD was input for a BCD input parameter to an instruction.	<ul style="list-style-type: none"> A hexadecimal digit of A, B, C, D, E, or F was input for a BCD input parameter to an instruction. 				S		W502
54010404 hex	Signed BCD Error	An illegal value was input for the most significant digit for a signed BCD input parameter to an instruction.	<ul style="list-style-type: none"> An illegal value was input for the most significant digit for a signed BCD input parameter to an instruction. The most-significant digit was 2 to F when <i>_BCD0</i> was specified as the BCD format. The most-significant digit was A, B, C, D, or E when <i>_BCD2</i> was specified as the BCD format. The most-significant digit was B, C, D, or E when <i>_BCD3</i> was specified as the BCD format. 				S		W502

Event code	Event name	Meaning	Assumed cause	Level					Reference
				Maj	Prt	Min	Obs	Info	
54010405 hex	Illegal Bit Position Specified	The bit position specified for an instruction was illegal.	<ul style="list-style-type: none"> The bit position specified for an instruction exceeds the data range. 				S		W502
54010406 hex	Illegal Data Position Specified	A memory address or data size that was specified for the instruction is not suitable.	<ul style="list-style-type: none"> A memory address that was specified for an instruction was outside the valid range. The data size that was specified for an instruction exceeded the valid range. For example, the data type of a variable and the data size may not agree. 				S		W502
54010407 hex	Data Range Exceeded	The results of instruction processing exceeded the data area range of the output parameter.	<ul style="list-style-type: none"> The results of instruction processing, such as the number of array elements, exceeded the data area range of the output parameter. 				S		W502
54010409 hex	No Errors to Clear	An instruction to clear a Controller error was executed when there was no error in the Controller.	<ul style="list-style-type: none"> An instruction to clear a Controller error was executed when there was no error in the Controller. 				S		W502
5401040B hex	No User Errors to Clear	An instruction to clear user-defined errors was executed when there was no user-defined error.	<ul style="list-style-type: none"> An instruction to clear user-defined errors was executed when there was no user-defined error. 				S		W502
5401040C hex	Limit Exceeded for User-defined Errors	An attempt was made to use the Create User-defined Error instruction to create more than the maximum number of user-defined errors.	<ul style="list-style-type: none"> An attempt was made to use the Create User-defined Error instruction to create more than the maximum number of user-defined errors. 				S		W502
5401040D hex	Illegal Unit Specified	The Unit specified for an instruction does not exist.	<ul style="list-style-type: none"> A Unit that does not exist in the Unit configuration information was specified. A Unit that is in the Unit configuration information was specified, but the Units does not actually exist in the Controller. 				S		W502
5401040F hex	Unit Restart Failed	Restarting a Special I/O Unit or CPU Bus Unit failed.	<ul style="list-style-type: none"> The Special I/O Unit or CPU Bus Unit is processing data. 				S		W502
54010410 hex	Text String Format Error	The text string input to an instruction is not correct.	<ul style="list-style-type: none"> The text string that is input to the instruction for conversion to a number does not represent a number or it does not represent a positive number. The input text string does not end in NULL. 				S		W502

Event code	Event name	Meaning	Assumed cause	Level					Reference
				Maj	Prt	Min	Obs	Info	
54010411 hex	Illegal Program Specified	The program specified for an instruction does not exist.	<ul style="list-style-type: none"> The program specified by the function does not exist (e.g., it was deleted). 				S		W502
54010413 hex	Undefined CJ-series Memory Address	The required specification is missing for a variable for which CJ-series Unit memory must be specified.	<ul style="list-style-type: none"> The required AT specification is missing for a variable for which CJ-series Unit memory must be specified. 				S		W502
54010414 hex	Stack Underflow	There is no data in a stack.	<ul style="list-style-type: none"> An attempt was made to read data from a stack that contains no data. 				S		W502
54010416 hex	Illegal Number of Array Elements or Dimensions	The valid range was exceeded for the number of array elements or dimensions in an array I/O parameter for an instruction.	<ul style="list-style-type: none"> The valid range was exceeded for the number of array elements or dimensions in an array I/O parameter for an instruction. 				S		W502
54010417 hex	Specified Task Does Not Exist	The task specified for the instruction does not exist.	<ul style="list-style-type: none"> The specified task does not exist. 				S		W502
54010418 hex	Unallowed Task Specification	An unallowed task was specified for an instruction.	<ul style="list-style-type: none"> The local task, the primary periodic task, or a periodic task was specified. 				S		W502
54010419 hex	Incorrect Data Type	A data type that cannot be used for an instruction is specified for an input or in-out variable.	<ul style="list-style-type: none"> A data type that cannot be used for an instruction is specified for an input or in-out variable. 				S		W502
5401041A hex	Multi-execution of Instructions	Multi-execution was specified for an instruction that does not support it.	<ul style="list-style-type: none"> Execution of an instruction that does not support multi-execution of instructions was specified more than once. 				S		W502
5401041B hex (Ver. 1.02 or later)	Data Capacity Exceeded	Processing was not possible because the data that was passed to the instruction was too large.	<ul style="list-style-type: none"> Data that exceeded the size that can be processed was passed to an instruction. 				S		W502
5401041C hex (Ver. 1.04 or later)	Different Data Sizes	The size of the data specified for instruction input or in-out data is different from the size of the target parameter.	<ul style="list-style-type: none"> Data of a size that is different from the size of the target parameter was specified for the input or in-out data of an instruction. 				S		W502
5401041D hex (Ver. 1.05 or later)	Exceeded Simultaneous Instruction Executed Resources	The maximum resources that you can use for the relevant instruction group at the same time was exceeded.	<ul style="list-style-type: none"> More than the maximum number of relevant instructions were executed at the same time. 				S		W502
54010800 hex	FINS Error	An error occurred when a FINS command was sent or received.	<ul style="list-style-type: none"> An error occurred when a FINS command was sent or received. 				S		W502
54010801 hex	FINS Port Already in Use	The FINS port is being used.	<ul style="list-style-type: none"> The FINS port is being used. 				S		W502

Event code	Event name	Meaning	Assumed cause	Level					Reference
				Maj	Prt	Min	Obs	Info	
54010C00 hex	Illegal Serial Communications Mode	The Serial Communications Unit is not in the serial communications mode required to execute an instruction.	<ul style="list-style-type: none"> The serial communications port for the Serial Communications Unit is not set to the mode expected by the instruction. 				S		W502
54010C03 hex (Ver. 1.11 or later)	Full Reception Buffer	The reception buffer is full.	<ul style="list-style-type: none"> The reception buffer is full. 				S		W502
54010C04 hex (Ver. 1.11 or later)	Multi-execution of Ports	The serial communications instructions that cannot be executed simultaneously were executed.	<ul style="list-style-type: none"> An instruction was executed while another instruction that cannot be executed at the same time with the former instruction was executed. 				S		W502
54010C05 hex (Ver. 1.11 or later)	Parity Error	A parity error occurred in the data received.	<ul style="list-style-type: none"> The communications settings or baud rate settings are not compatible with the remote device. Noise 				S		W502
54010C06 hex (Ver. 1.11 or later)	Framing Error	A framing error occurred in the data received.	<ul style="list-style-type: none"> The communications settings or baud rate settings are not compatible with the remote device. Noise 				S		W502
54010C07 hex (Ver. 1.11 or later)	Overrun Error	An overrun error occurred in the data received.	<ul style="list-style-type: none"> The next data was received during processing of received data because the baud rate is too high. 				S		W502
54010C08 hex (Ver. 1.11 or later)	CRC Mismatch	The receive data had different CRC.	<ul style="list-style-type: none"> A wrong message was received. Noise 				S		W502
54010C0B hex (Ver. 1.11 or later)	Serial Communications Timeout	A timeout occurred in serial communications.	<ul style="list-style-type: none"> Wiring to the remote device is not connected. Power to the remote device is OFF. The communications settings or baud rate settings are not compatible with the remote device. Noise 				S		W502
54010C0C hex (Ver. 1.11 or later)	Instruction Executed to Inapplicable Port	An instruction was executed to an inapplicable port.	<ul style="list-style-type: none"> An instruction was executed to an inapplicable port. 				S		W502
54010C0D hex (Ver. 1.13 or later)	CIF Unit Initialized	A CIF Unit was initialized, so the communications data buffered in the CIF Unit was lost.	<ul style="list-style-type: none"> A CIF Unit was initialized. 				S		W502
54010C10 hex (Ver. 1.11 or later)	Exceptional Modbus Response	An exceptional code was returned from the Modbus slave.	<ul style="list-style-type: none"> An error was detected on the Modbus slave. 				S		W502

Event code	Event name	Meaning	Assumed cause	Level					Reference
				Maj	Prt	Min	Obs	Info	
54010C11 hex (Ver. 1.11 or later)	Invalid Modbus Response	An unexpected response was returned from the Modbus slave.	<ul style="list-style-type: none"> The function code or data size of the response received from the Modbus slave was incorrect. 				S		W502
54011400 hex	SD Memory Card Access Failure	SD Memory Card access failed when an instruction was executed.	<ul style="list-style-type: none"> An SD Memory Card is either not inserted or is not inserted properly. The SD Memory Card is broken. The SD Memory Card slot is broken. 				S		W502
54011401 hex	SD Memory Card Write-protected	An attempt was made to write to a write-protected SD Memory Card when an instruction was executed.	<ul style="list-style-type: none"> An attempt was made to write to a write-protected SD Memory Card. 				S		W502
54011402 hex	SD Memory Card Insufficient Capacity	The capacity of the SD Memory Card was insufficient when writing to the SD Memory Card for an instruction.	<ul style="list-style-type: none"> The SD Memory Card has run out of free space. 				S		W502
54011403 hex	File Does Not Exist	The file specified for an instruction does not exist. Or, the specified file is corrupted.	<ul style="list-style-type: none"> The specified file does not exist. The specified file is corrupted. The SD Memory Card cannot be normally accessed due to a contact failure or other causes. 				S		W502
54011404 hex	Too Many Files/Directories	The maximum number of files/directories was exceeded when creating a file/directory for an instruction.	<ul style="list-style-type: none"> The number of files or directories exceeded the maximum number. 				S		W502
54011405 hex	File Already in Use	A file specified for an instruction cannot be accessed because it is already being used.	<ul style="list-style-type: none"> An instruction attempted to read or write a file already being accessed by another instruction. 				S		W502
54011406 hex	Open Mode Mismatch	A file operation for an instruction was inconsistent with the open mode of the file.	<ul style="list-style-type: none"> The file open mode specified by the Open File instruction does not match the file operation attempted by a subsequent SD Memory Card instruction. 				S		W502
54011407 hex	Offset Out of Range	Access to the address is not possible for the offset specified for an instruction.	<ul style="list-style-type: none"> An attempt was made to access beyond the size of the file. 				S		W502
54011408 hex	Directory Not Empty	A directory was not empty when the Delete Directory instruction was executed or when an attempt was made to change the directory name.	<ul style="list-style-type: none"> A directory was not empty when the Delete Directory instruction was executed. A directory contained another directory when an attempt was made to change the directory name. 				S		W502

Event code	Event name	Meaning	Assumed cause	Level					Reference
				Maj	Prt	Min	Obs	Info	
54011409 hex	That File Name Already Exists	An instruction could not be executed because the file name specified for the instruction already exists.	<ul style="list-style-type: none"> A file already exists with the same name as the name specified for the instruction to create. 				S		W502
5401140A hex	Write Access Denied	An attempt was made to write to a write-protected file or directory when an instruction was executed.	<ul style="list-style-type: none"> The file or directory specified for the instruction to write is write-protected. 				S		W502
5401140B hex	Too Many Files Open	The maximum number of open files was exceeded when opening a file for an instruction.	<ul style="list-style-type: none"> The maximum number of open files was exceeded when opening a file for an instruction. 				S		W502
5401140C hex	Directory Does Not Exist	The directory specified for an instruction does not exist.	<ul style="list-style-type: none"> The directory specified for an instruction does not exist. 				S		W502
5401140D hex	File or Directory Name Is Too Long	The file name or directory name that was specified for an instruction is too long.	<ul style="list-style-type: none"> The file name or directory name that was specified for the instruction to create is too long. 				S		W502
5401140E hex	SD Memory Card Access Failed	SD Memory Card access failed.	<ul style="list-style-type: none"> The SD Memory Card is broken. The SD Memory Card slot is broken. 				S		W502
5401140F hex (Ver. 1.08 or later)	Backup Operation Already in Progress	Another backup operation is already in progress.	<ul style="list-style-type: none"> Another backup operation is already in progress. 				S		W502
54011410 hex (Ver. 1.08 or later)	Cannot Execute Backup	Execution of a backup operation was not possible because execution of another operation was in progress.	<ul style="list-style-type: none"> Execution of the instruction was attempted during execution of online editing. Execution of the instruction was attempted during execution of a Save Cam Table instruction. Execution of the instruction was attempted while a CPU Unit name change operation was in progress. 				S		W502
54011411 hex (Ver. 1.08 or later)	Unit/Slave Backup Failed	A Unit/slave backup operation failed.	<ul style="list-style-type: none"> A Unit/slave backup operation failed. 				S		W502
54011800 hex	EtherCAT Communications Error	Accessing the EtherCAT network failed when an instruction was executed.	<ul style="list-style-type: none"> The EtherCAT network is not in a usable status. 				S		W502
54011801 hex	EtherCAT Slave Does Not Respond	Accessing the target slave failed when an instruction was executed.	<ul style="list-style-type: none"> The target slave does not exist. The target slave is not in an operating condition. 				S		W502
54011802 hex	EtherCAT Timeout	A timeout occurred while trying to access an EtherCAT slave when an instruction was executed.	<ul style="list-style-type: none"> Communications with the target slave timed out. 				S		W502

Event code	Event name	Meaning	Assumed cause	Level					Reference
				Maj	Prt	Min	Obs	Info	
54011803 hex	Reception Buffer Overflow	The receive data from an EtherCAT slave overflowed the receive buffer when an instruction was executed.	<ul style="list-style-type: none"> The receive data from the slave overflowed the receive buffer. 				S		W502
54011804 hex	SDO Abort Error	An SDO abort error was received from an EtherCAT slave when an instruction was executed.	<ul style="list-style-type: none"> Depends on the specifications of the slave. 				S		W502
54011805 hex	Saving Packet Monitor File	An instruction for packet monitoring was executed while saving an EtherCAT packet monitor file.	<ul style="list-style-type: none"> An instruction for packet monitoring was executed while saving an EtherCAT packet monitor file. 				S		W502
54011806 hex	Packet Monitoring Function Not Started	A Stop EtherCAT Packet Monitor instruction was executed when EtherCAT packet monitoring was stopped.	<ul style="list-style-type: none"> A Stop EtherCAT Packet Monitor instruction was executed when EtherCAT packet monitoring was stopped. 				S		W502
54011807 hex	Packet Monitoring Function in Operation	A Start EtherCAT Packet Monitor instruction was executed when EtherCAT packet monitoring was already being executed.	<ul style="list-style-type: none"> The Start EtherCAT Packet Monitor instruction was executed again while the EtherCAT packet monitoring function was already in operation. 				S		W502
54011808 hex	Communications Resource Overflow	More than 32 EtherCAT communications instructions were executed at the same time.	<ul style="list-style-type: none"> More than 32 EtherCAT communications instructions were executed at the same time. The EtherCAT communications instructions are listed below. <ul style="list-style-type: none"> EC_CoESDOWrite instruction EC_CoESDORead instruction EC_ConnectSlave instruction EC_DisconnectSlave instruction EC_StartMon instruction EC_SaveMon instruction EC_StopMon instruction EC_CopyMon instruction 				S		W502
54011809 hex (Ver. 1.01 or later)	Packet Monitoring Function Not Supported	Packets cannot be monitored.	<ul style="list-style-type: none"> An instruction for packet monitoring was executed for a CPU Unit that does not support packet monitoring. 				S		W502
54011C00 hex	Explicit Message Error	An error response code was returned for an explicit message that was sent with a CIP communications instruction.	<ul style="list-style-type: none"> Depends on the nature of the error. 				S		W502

Event code	Event name	Meaning	Assumed cause	Level					Reference
				Maj	Prt	Min	Obs	Info	
54011C01 hex	Incorrect Route Path	The format of the route path that is specified for a CIP communications instruction is not correct.	<ul style="list-style-type: none"> The format of the route path that is specified for a CIP communications instruction is not correct. 				S		W502
54011C02 hex	CIP Handle Out of Range	The handle that is specified for the CIP communications instruction is not correct.	<ul style="list-style-type: none"> The handle that is specified for the CIP communications instruction is not correct. 				S		W502
54011C03 hex	CIP Communications Resource Overflow	The maximum resources that you can use for CIP communications instructions at the same time was exceeded.	<ul style="list-style-type: none"> More than 32 CIP communications instructions were executed at the same time. An attempt was made to use more than 32 handles at the same time. 				S		W502
54011C04 hex	CIP Timeout	A CIP timeout occurred during execution of a CIP communications instruction.	<ul style="list-style-type: none"> A device does not exist for the specified IP address. The CIP connection for the specified handle timed out and was closed. Power to the remote device is OFF. Communications are stopped at the remote device. The Ethernet cable connector for EtherNet/IP is disconnected. The Ethernet cable for EtherNet/IP is disconnected. Noise 				S		W502
54011C05 hex (Ver. 1.06 or later)	Class-3 Connection Not Established	Establishing a class-3 connection failed for a CIP communications instruction.	<ul style="list-style-type: none"> The CIPOpen instruction was executed for a device that does not support class 3 (Large_Forward_Open). The CIPOpenWithDataSize instruction was executed with a specified data size of 510 bytes or larger for a device that does not support class 3 (Large_Forward_Open). 				S		W502

Event code	Event name	Meaning	Assumed cause	Level					Reference
				Maj	Prt	Min	Obs	Info	
54011C06 hex (Ver. 1.06 or later)	CIP Communications Data Size Exceeded	An attempt was made to send a class-3 explicit message with a data size that is larger than the sendable size with a CIP communications instruction.	<ul style="list-style-type: none"> The data size that was specified for the input variable to the CIP-Read, CIPWrite, or CIPSend instruction exceeded the data size that was specified with the CIPOpen-WithData-Size instruction. 				S		W502
54012000 hex	Local IP Address Setting Error	An instruction was executed when there was a setting error in the local IP address.	<ul style="list-style-type: none"> An instruction was executed when there was a setting error in the local IP address. 				S		W502
54012001 hex	TCP/UDP Port Already in Use	The UDP or TCP port was already in use when the instruction was executed.	<ul style="list-style-type: none"> The UDP or TCP port is already in use. 				S		W502
54012002 hex	Address Resolution Failed	Address resolution failed for a remote node with the host name that was specified in the instruction.	<ul style="list-style-type: none"> The host name specified for the instruction is not correct. The hosts and DNS settings in the Controller are incorrect. The DNS server settings are incorrect. 				S		W502

Event code	Event name	Meaning	Assumed cause	Level					Reference
				Maj	Prt	Min	Obs	Info	
54012003 hex	Socket Status Error	The status was not suitable for execution of the socket service instruction.	<ul style="list-style-type: none"> • SktUDPCreate Instruction The UDP port specified with the <i>SrcUdpPort</i> input variable is in one of the following states. <ul style="list-style-type: none"> • It is already open. • It is being closed. • SktUDPRcv Instruction <ul style="list-style-type: none"> • The specified socket is receiving data. • The specified socket is closed. • SktUDPSend Instruction <ul style="list-style-type: none"> • The specified socket is sending data. • The specified socket is closed. • SktTCPAccept Instruction The specified TCP port is in one of the following states. <ul style="list-style-type: none"> • The port is being opened. • The port is being closed. • A connection is already established for this instruction for the same IP address and TCP port. • SktTCPConnect Instruction <ul style="list-style-type: none"> • The TCP port that is specified with the <i>SrcTcpPort</i> input variable is already open. • The remote node that is specified with <i>DstAdr</i> input variable does not exist. • The remote node that is specified with <i>DstAdr</i> and <i>DstTcpPort</i> input variables is not waiting for a connection. • SktTCPRcv Instruction <ul style="list-style-type: none"> • The specified socket is receiving data. • The specified socket is closed. 				S		W502

Event code	Event name	Meaning	Assumed cause	Level					Reference
				Maj	Prt	Min	Obs	Info	
54012003 hex	Socket Status Error	The status was not suitable for execution of the socket service instruction.	<ul style="list-style-type: none"> • SktTCPSend Instruction <ul style="list-style-type: none"> • The specified socket is sending data. • The specified socket is closed. • The send buffer of the specified socket is full (because the power to the remote node is OFF, the line is disconnected, etc.) • SktSetOption Instruction <ul style="list-style-type: none"> • The specified socket already started transmission. • An option type which is not supported by the specified socket was selected. 				S		W502
54012004 hex	Local IP Address Not Set	The local IP address was not set when a socket service instruction was executed.	<ul style="list-style-type: none"> • There is a BOOTP server setting error. • The BOOTP server does not exist. • The local IP address is not set because operation just started. 				S		W502
54012006 hex	Socket Timeout	A timeout occurred for a socket service instruction.	<ul style="list-style-type: none"> • SktTCPAccept instruction: There was no request for a connection from the remote node during the user-set timeout time. • SktTCPRcv or SktUDPRcv instruction: Data was not received from the remote node during the user-set timeout time. 				S		W502
54012007 hex	Socket Handle Out of Range	The handle that is specified for the socket service instruction is not correct.	<ul style="list-style-type: none"> • The handle that is specified for the socket service instruction is not correct. 				S		W502
54012008 hex	Socket Communications Resource Overflow	The maximum resources that you can use for socket service instructions at the same time was exceeded.	<ul style="list-style-type: none"> • More than 32 socket service instructions were executed at the same time. • More than 30 socket handles were used at the same time. (For CPU Units with unit version 1.02 or earlier, more than 16 socket handles were used at the same time.) 				S		W502

Event code	Event name	Meaning	Assumed cause	Level					Reference
				Maj	Prt	Min	Obs	Info	
54012400 hex (Ver. 1.02 or later)	No Execution Right	An instruction to change the settings of an EtherNet/IP port was executed when execution was not possible.	<ul style="list-style-type: none"> An instruction to change the settings of the built-in EtherNet/IP port or a CJ-series EtherNet/IP Unit was executed when restart processing was in progress for the built-in EtherNet/IP port. An instruction to change the settings of a CJ-series EtherNet/IP Unit was executed when restart processing was in progress for the Unit. An instruction to change the settings of the built-in EtherNet/IP port or a CJ-series EtherNet/IP Unit was executed when changing settings was in progress for an instruction or CIP message for the built-in EtherNet/IP port. An instruction to change the settings of a CJ-series EtherNet/IP Unit was executed when changing settings was in progress for an instruction or CIP message for the Unit. The unit number that was specified for the instruction is not for a built-in EtherNet/IP port or a CJ-series EtherNet/IP Unit. 				S		W502
54012401 hex (Ver. 1.02 or later)	Settings Update Failed	It was not possible to update the settings of the CJ-series EtherNet/IP Unit that were changed.	<ul style="list-style-type: none"> Restart processing for a Unit or built-in EtherNet/IP port was started during execution of an instruction to change the settings of a CJ-series EtherNet/IP Unit. 				S		W502
54012402 hex (Ver. 1.02 or later)	Too Many Simultaneous Instruction Executions	Too many instructions to change the communications setup of the Controller were executed at the same time.	<ul style="list-style-type: none"> Two or more instructions to change the communications setup of the Controller were executed at the same time. 				S		W502
54012403 hex (Ver. 1.08 or later)	FTP Client Execution Limit Exceeded	Too many FTP client communications instructions were executed at the same time.	<ul style="list-style-type: none"> Four or more FTP client communications instructions were executed at the same time. 				S		W502

Event code	Event name	Meaning	Assumed cause	Level					Reference
				Maj	Prt	Min	Obs	Info	
54012404 hex (Ver. 1.08 or later)	File Number Limit Exceeded	The number of files specified with a wildcard for an FTP client communications instruction exceeded 1,000.	<ul style="list-style-type: none"> The number of files specified with a file name that contained a wildcard for an FTP client communications instruction exceeded 1,000. 				S		W502
54012405 hex (Ver. 1.08 or later)	Directory Does Not Exist (FTP)	The directory specified for an FTP client communications instruction does not exist in the Controller or an incorrect path was specified.	<ul style="list-style-type: none"> The directory specified for an FTP client communications instruction does not exist in the Controller or an incorrect path was specified. 				S		W502
54012406 hex (Ver. 1.08 or later)	FTP Server Connection Error	The destination FTP server that was specified for an FTP client communications instruction does not exist on the network or the specified FTP server is not operating.	<ul style="list-style-type: none"> The destination FTP server that was specified for an FTP client communications instruction does not exist on the network. The destination FTP server that was specified for an FTP client communications instruction is not operating. 				S		W502
54012407 hex (Ver. 1.08 or later)	Destination FTP Server Execution Failure	The destination FTP server for an FTP client communications instruction returned an error.	<ul style="list-style-type: none"> The destination FTP server for the FTP client communications instruction failed to execute the requested processing. 				S		W502
54012408 hex (Ver. 1.08 or later)	SD Memory Card Access Failed for FTP	SD Memory Card access from the FTP client failed.	<ul style="list-style-type: none"> An SD Memory Card is not inserted. The SD Memory Card was removed during execution of the FTP client communications instruction. The capacity of the SD Memory Card is insufficient. The SD Memory Card is write protected. 				S		W502
54012409 hex (Ver. 1.08 or later)	Specified File Does Not Exist	A file specified for an FTP client communications instruction does not exist.	<ul style="list-style-type: none"> A file specified for an FTP client communications instruction does not exist. 				S		W502
5401240A hex (Ver. 1.08 or later)	Specified File Is Write Protected	The data was not transferred because the FTP client communications instruction was set to not overwrite files with the same name.	<ul style="list-style-type: none"> The data was not transferred because the FTP client communications instruction was set to not overwrite files with the same name and a file with the specified file name already existed at the destination. 				S		W502

Event code	Event name	Meaning	Assumed cause	Level					Reference
				Maj	Prt	Min	Obs	Info	
5401240B hex (Ver. 1.08 or later)	Failed To Delete Specified File	A file was not deleted after it was transferred with an FTP client communications instruction.	<ul style="list-style-type: none"> The FTP client communications instruction was set to delete files after they are transferred, but it was not possible to delete the specified file because it had a read-only attribute. It was not possible to delete the file specified for the FTP client communications instruction because it was in use by another application. 				S		W502
5401240C hex (Ver. 1.08 or later)	Specified File Access Failed	An FTP transfer for an FTP client communications instruction failed because file access failed.	<ul style="list-style-type: none"> The file specified for the FTP client communications instruction was in use by another application. The file or directory specified for the FTP client communications instruction to write is write protected. 				S		W502
5401240D hex (Ver. 1.10 or later)	IP Address Setting Invalid	Instruction execution was not possible because there is an error between the IP address setting of the port specified in the instruction and the other port settings.	<ul style="list-style-type: none"> The network address of the port specified in the instruction is the same as the network address of another port. Both the port specified in the instruction and the other ports are set as unused ports. 				S		W502
54012C00 hex (Ver. 1.05 or later)	NX Message Error	An error response code was returned for an NX message.	<ul style="list-style-type: none"> Depends on the nature of the error. 				S		W502
54012C01 hex (Ver. 1.05 or later)	NX Message Resource Overflow	The maximum resources that you can use for NX message instructions at the same time was exceeded.	<ul style="list-style-type: none"> More than 32 NX message instructions were executed at the same time. 				S		W502
54012C02 hex (Ver. 1.05 or later)	NX Message Timeout	A timeout occurred during execution of an NX message.	<ul style="list-style-type: none"> The specified NX Unit does not exist. The NX message was closed because it timed out. Power to the remote Unit is OFF. Communications are stopped at the remote Unit. The communications cable connector is disconnected. The communications cable is broken. Noise 				S		W502
54012C03 hex (Ver. 1.05 or later)	Incorrect NX Message Length	The length of the NX message is not correct.	<ul style="list-style-type: none"> The size that is specified for WriteDat or Path is too long. 				S		W502

Event code	Event name	Meaning	Assumed cause	Level					Reference
				Maj	Prt	Min	Obs	Info	
54012C05 hex (Ver. 1.05 or later)	NX Message EtherCAT Network Error	An error occurred in EtherCAT communications on the NX message path.	<ul style="list-style-type: none"> An error occurred in EtherCAT communications on the NX message path. 				S		W502
54012C06 hex (Ver. 1.05 or later)	External Restart Already Executed for Specified NX Units	A restart was already in execution from the Sysmac Studio when the instruction was executed.	<ul style="list-style-type: none"> A restart was already in execution from the Sysmac Studio when the instruction was executed. 				S		W502
54012C07 hex (Ver. 1.05 or later)	Unapplicable Unit Specified for Instruction	A slave that cannot be specified for the instruction was connected at the slave node address of the specified Unit.	<ul style="list-style-type: none"> A slave that cannot be specified for the instruction was connected to the slave node address of the specified Unit. 				S		W502
54012C08 hex (Ver. 1.10 or later)	Invalid Total Power ON Time Record	The total power ON time could not be read.	<ul style="list-style-type: none"> Non-volatile memory failure 				S		W502
54013461 hex	Process Data Object Setting Missing	The PDO mapping is not correct.	<ul style="list-style-type: none"> The PDOs that are required for the motion control instruction are not mapped. The relevant instruction was executed for a device that does not have an object that supports the instruction. A motion control instruction that specifies phase Z (<code>_mcEncoderMark</code>) as the trigger conditions was executed for an axis that is mapped to an OMRON GX-EC02□□ EtherCAT Encoder slave. 				S		W502
54014800 hex (Ver. 1.12 or later)	Device Error Received	An error response from the device was received.	<ul style="list-style-type: none"> An error response from the device was received. 				S		W502
54014801 hex (Ver. 1.12 or later)	Specified Unit Does Not Exist	The specified Unit does not exist.	<ul style="list-style-type: none"> The IO-Link master is not connected to or mounted on the specified position. 				S		W502
54014802 hex (Ver. 1.12 or later)	Message Processing Limit Exceeded	An instruction cannot be executed because the IO-Link master is processing the message from another application.	<ul style="list-style-type: none"> An instruction cannot be executed because the IO-Link master is processing the message from another application (an instruction execution or a tool connection). 				S		W502
54014803 hex (Ver. 1.12 or later)	Specified Unit Status Error	The specified Unit is not in a condition to receive messages.	<ul style="list-style-type: none"> The specified Unit is not in a condition to receive messages. 				S		W502
54014804 hex (Ver. 1.12 or later)	Too Many Simultaneous Instruction Executions	The number of instructions that can be simultaneously executed was exceeded.	<ul style="list-style-type: none"> More than 32 NX message instructions and EtherCAT communications instructions were executed at the same time. 				S		W502

Event code	Event name	Meaning	Assumed cause	Level					Reference
				Maj	Prt	Min	Obs	Info	
54014805 hex (Ver. 1.12 or later)	Communications Timeout	A timeout occurred in communications.	<ul style="list-style-type: none"> The communications timeout time is shorter than the message response time. The cable for Ether-CAT or for IO-Link is broken. Noise Device failure 				S		W502
54014806 hex (Ver. 1.12 or later)	Invalid Mode	The specified IO-Link master port is not the IO-Link mode.	<ul style="list-style-type: none"> The specified IO-Link master port is not the IO-Link mode. 				S		W502
54014807 hex (Ver. 1.12 or later)	I/O Power OFF Status	The I/O power is not supplied to the specified IO-Link master port.	<ul style="list-style-type: none"> The I/O power is not supplied to the specified IO-Link master port. 				S		W502
54014808 hex (Ver. 1.12 or later)	Verification Error	The specified IO-Link master port had a verification error or a communications error.	<ul style="list-style-type: none"> The specified IO-Link master port had a verification error or a communications error. 				S		W502
54015420 hex	Electronic Gear Ratio Numerator Setting Out of Range	The parameter specified for the <i>RatioNumerator</i> input variable to a motion control instruction is out of range.	<ul style="list-style-type: none"> Instruction input parameter exceeded the valid range of the input variable. 				S		W502
54015421 hex	Electronic Gear Ratio Denominator Setting Out of Range	The parameter specified for the <i>RatioDenominator</i> input variable to a motion control instruction is out of range.	<ul style="list-style-type: none"> Instruction input parameter exceeded the valid range of the input variable. 				S		W502
54015422 hex	Target Velocity Setting Out of Range	The parameter specified for the <i>Velocity</i> input variable to a motion control instruction is out of range.	<ul style="list-style-type: none"> Instruction input parameter exceeded the valid range of the input variable. 				S		W502
54015423 hex	Acceleration Setting Out of Range	The parameter specified for the <i>Acceleration</i> input variable to a motion control instruction is out of range.	<ul style="list-style-type: none"> Instruction input parameter exceeded the valid range of the input variable. 				S		W502
54015424 hex	Deceleration Setting Out of Range	The parameter specified for the <i>Deceleration</i> input variable to a motion control instruction is out of range.	<ul style="list-style-type: none"> Instruction input parameter exceeded the valid range of the input variable. 				S		W502
54015425 hex	Jerk Setting Out of Range	The parameter specified for the <i>Jerk</i> input variable to a motion control instruction is out of range.	<ul style="list-style-type: none"> Instruction input parameter exceeded the valid range of the input variable. 				S		W502
54015427 hex	Torque Ramp Setting Out of Range	The parameter specified for the <i>TorqueRamp</i> input variable to a motion control instruction is out of range.	<ul style="list-style-type: none"> Instruction input parameter exceeded the valid range of the input variable. 				S		W502
54015428 hex	Master Coefficient Scaling Out of Range	The parameter specified for the <i>MasterScaling</i> input variable to a motion control instruction is out of range.	<ul style="list-style-type: none"> Instruction input parameter exceeded the valid range of the input variable. 				S		W502
54015429 hex	Slave Coefficient Scaling Out of Range	The parameter specified for the <i>SlaveScaling</i> input variable to a motion control instruction is out of range.	<ul style="list-style-type: none"> Instruction input parameter exceeded the valid range of the input variable. 				S		W502
5401542A hex	Feeding Velocity Setting Out of Range	The parameter specified for the <i>FeedVelocity</i> input variable to a motion control instruction is out of range.	<ul style="list-style-type: none"> The Feed Velocity (input variable <i>FeedVelocity</i>) is still at the default (0). 				S		W502

Event code	Event name	Meaning	Assumed cause	Level					Reference
				Maj	Prt	Min	Obs	Info	
5401542B hex	Buffer Mode Selection Out of Range	The parameter specified for the <i>BufferMode</i> input variable to a motion control instruction is out of range.	<ul style="list-style-type: none"> Instruction input parameter exceeded the valid range of the input variable. 				S		W502
5401542C hex	Coordinate System Selection Out of Range	The parameter specified for the <i>CoordSystem</i> input variable to a motion control instruction is out of range.	<ul style="list-style-type: none"> Instruction input parameter exceeded the valid range of the input variable. 				S		W502
5401542D hex	Circular Interpolation Mode Selection Out of Range	The parameter specified for the <i>CircMode</i> input variable to a motion control instruction is out of range.	<ul style="list-style-type: none"> Instruction input parameter exceeded the valid range of the input variable. 				S		W502
5401542E hex	Direction Selection Out of Range	The parameter specified for the <i>Direction</i> input variable to a motion control instruction is out of range.	<ul style="list-style-type: none"> Instruction input parameter exceeded the valid range of the input variable. 				S		W502
5401542F hex	Path Selection Out of Range	The parameter specified for the <i>PathChoice</i> input variable to a motion control instruction is out of range.	<ul style="list-style-type: none"> Instruction input parameter exceeded the valid range of the input variable. 				S		W502
54015430 hex	Position Type Selection Out of Range	The parameter specified for the <i>ReferenceType</i> input variable to a motion control instruction is out of range.	<ul style="list-style-type: none"> Instruction input parameter exceeded the valid range of the input variable. 				S		W502
54015431 hex	Travel Mode Selection Out of Range	The parameter specified for the <i>MoveMode</i> input variable to a motion control instruction is out of range.	<ul style="list-style-type: none"> Instruction input parameter exceeded the valid range of the input variable. 				S		W502
54015432 hex	Transition Mode Selection Out of Range	The parameter specified for the <i>TransitionMode</i> input variable to a motion control instruction is out of range.	<ul style="list-style-type: none"> Instruction input parameter exceeded the valid range of the input variable. <i>_mcAborting</i> or <i>_mcBuffered</i> was specified for <i>BufferMode</i> and <i>_mcTMCornerSuperimposed</i> was specified for <i>TransitionMode</i>. 				S		W502
54015433 hex	Continue Method Selection Out of Range	The value of the reserved input variable <i>Continuous</i> to a motion control instruction changed.	<ul style="list-style-type: none"> The value of the reserved input variable <i>Continuous</i> changed. 				S		W502
54015434 hex	Combine Mode Selection Out of Range	The parameter specified for the <i>CombineMode</i> input variable to a motion control instruction is out of range.	<ul style="list-style-type: none"> Instruction input parameter exceeded the valid range of the input variable. 				S		W502
54015435 hex	Synchronization Start Condition Selection Out of Range	The parameter specified for the <i>LinkOption</i> input variable to a motion control instruction is out of range.	<ul style="list-style-type: none"> Instruction input parameter exceeded the valid range of the input variable. 				S		W502
54015436 hex	Master and Slave Defined as Same Axis	The same axis is specified for the <i>Master</i> and <i>Slave</i> input variables to a motion control instruction.	<ul style="list-style-type: none"> The parameter is the same for the <i>Master</i> and <i>Slave</i> input variables to the instruction. 				S		W502
54015437 hex	Master and Auxiliary Defined as Same Axis	The same axis is specified for the <i>Master</i> and <i>Auxiliary</i> input variables to a motion control instruction.	<ul style="list-style-type: none"> The parameter is the same for the <i>Master</i> and <i>Auxiliary</i> input variables to the instruction. 				S		W502

Event code	Event name	Meaning	Assumed cause	Level					Reference
				Maj	Prt	Min	Obs	Info	
54015438 hex	Master/Slave Axis Numbers Not in Ascending Order	The axis numbers specified for the <i>Master</i> and <i>Slave</i> input variables to a motion control instruction are not in ascending order.	<ul style="list-style-type: none"> The parameters for the <i>Master</i> and <i>Slave</i> input variables to the instruction were not in ascending order when <i>_mcLatestCommand</i> was specified for the <i>ReferenceType</i> input variable to the instruction. 				S		W502
54015439 hex	Incorrect Cam Table Specification	The parameter specified for the <i>CamTable</i> input variable to a motion control instruction is out of range.	<ul style="list-style-type: none"> Something other than a cam data variable was specified for the <i>CamTable</i> input variable to the instruction. 				S		W502
5401543A hex	Synchronization Stopped	A synchronized control motion control instruction was executed, but conditions required for execution were not met.	<ul style="list-style-type: none"> The MC_CamOut (End Cam Operation) instruction was executed even though the MC_CamIn (Start Cam Operation) instruction is not being executed. The MC_GearOut (End Gear Operation) instruction was executed even though the MC_GearIn (Start Gear Operation) or the MC_GearInPos (Positioning Gear Operation) instruction is not being executed. The MC_Phasing (Shift Master Axis Phase) instruction was executed even though the MC_CamIn (Start Cam Operation), MC_GearIn (Start Gear Operation), MC_GearInPos (Start Gear Operation), or MC_MoveLink (Synchronous Positioning) instruction is not being executed. 				S		W502
5401543B hex	Motion Control Instruction Re-execution Disabled	An attempt was made to re-execute a motion control instruction that cannot be re-executed.	<ul style="list-style-type: none"> A motion control instruction that cannot be re-executed was re-executed. 				S		W502
5401543C hex	Motion Control Instruction Multi-execution Disabled	Multiple functions that cannot be executed simultaneously were executed for the same target (MC common, axis, or axes group).	<ul style="list-style-type: none"> Multiple functions that cannot be executed simultaneously were executed for the same target (MC common or axis). 				S		W502
5401543D hex	Instruction Not Allowed for Encoder Axis Type	An operation instruction was executed for an encoder axis.	<ul style="list-style-type: none"> An operation instruction was executed for an encoder axis. 				S		W502

Event code	Event name	Meaning	Assumed cause	Level					Reference
				Maj	Prt	Min	Obs	Info	
5401543E hex	Instruction Cannot Be Executed during Multi-axes Coordinated Control	<ul style="list-style-type: none"> An operation instruction was executed for an axis or an axes group that was in a coordinated multi-axes motion. A robot instruction that you cannot use for an axes group in a <i>GroupEnable</i> state was executed. 	<ul style="list-style-type: none"> An operation instruction was executed for an axis or an axes group that was in a coordinated multi-axes motion. The MC_SetKinTransform instruction was executed for an axes group in a <i>GroupEnable</i> state. 				S		W502
5401543F hex	Multi-axes Coordinated Control Instruction Executed for Disabled Axes Group	A multi-axes coordinated control instruction was executed for an axes group that was in a <i>GroupDisable</i> state.	<ul style="list-style-type: none"> A multi-axes coordinated control instruction was executed for an axes group that was in a <i>GroupDisable</i> state. One of the following instructions was executed for an axes group that was in a <i>GroupDisable</i> state. MC_MoveTimeAbsolute MC_SyncLinearConveyor MC_SyncOut MC_RobotJog 				S		W502
54015440 hex	Axes Group Cannot Be Enabled	Execution of the MC_GroupEnable (Enable Axes Group) instruction failed.	<ul style="list-style-type: none"> When the MC_GroupEnable (Enable Axes Group) instruction was executed, there was a composition axis that was not stopped. When the MC_GroupEnable (Enable Axes Group) instruction was executed, there was a composition axis for which the MC_TouchProbe (Enable External Latch) instruction was being executed. 				S		W502
54015441 hex	Impossible Axis Operation Specified when the Servo is OFF	An operation instruction was executed for an axis for which the Servo is OFF.	<ul style="list-style-type: none"> An operation instruction was executed for an axis for which the Servo is OFF. Home was preset with the MC_Home or MC_HomeWithParameter instruction for an axis for which EtherCAT process data communications are not established. 				S		W502
54015442 hex	Composition Axis Stopped Error	A motion instruction was executed for an axes group while the MC_Stop instruction was being executed for a composition axis.	<ul style="list-style-type: none"> A motion instruction was executed for an axes group while the MC_Stop instruction was being executed for a composition axis. 				S		W502

Event code	Event name	Meaning	Assumed cause	Level					Refer- ence
				Maj	Prt	Min	Obs	Info	
54015443 hex	Motion Control Instruction Multi-execution Buffer Limit Exceeded	The number of motion control instructions that is buffered for Buffered or Blending Buffer Modes exceeded the buffer limit.	<ul style="list-style-type: none"> An axis instruction was executed when there was already a current instruction and a buffered instruction for the same axis. An axes group instruction was executed when there was already eight current instructions and buffered instructions for the same axis. 				S		W502
54015444 hex	Insufficient Travel Distance	The specified motion cannot be executed for the deceleration rate or acceleration rate that was specified for multi-execution or re-execution of a positioning instruction.	<ul style="list-style-type: none"> Stopping at the target position was not possible for the specified acceleration/deceleration rate for multi-execution or re-execution of a positioning instruction when the Acceleration/Deceleration Over parameter was set to generate a minor fault and stop. 				S		W502
54015445 hex	Insufficient Travel Distance to Achieve Blending Transit Velocity	There is not sufficient travel distance to accelerate or decelerate to the transit velocity.	<ul style="list-style-type: none"> There was not sufficient travel distance to accelerate the current command to the transit velocity when the Acceleration/Deceleration Over parameter was set to generate a minor fault and stop. 				S		W502
54015446 hex	Move Link Constant Velocity Insufficient Travel Distance	The constant-velocity travel distance of the master axis is less than zero.	<ul style="list-style-type: none"> The constant velocity travel distance of the master axis is below 0 for the MC_MoveLink (Synchronous Positioning) instruction. 				S		W502
54015447 hex	Positioning Gear Operation Insufficient Target Velocity	For the MC_GearInPos (Positioning Gear Operation) instruction, the target velocity of the slave axis is too small to achieve the required velocity.	<ul style="list-style-type: none"> For the MC_GearInPos (Positioning Gear Operation) instruction, the value of the <i>Velocity</i> (Target Velocity) input variable is smaller than the master axis velocity multiplied by the gear ratio when the instruction was executed. 				S		W502

Event code	Event name	Meaning	Assumed cause	Level					Reference
				Maj	Prt	Min	Obs	Info	
54015448 hex	Same Start Point and End Point for Circular Interpolation	The start point and end point were the same when the radius method was specified for the MC_MoveCircular2D (Circular 2D Interpolation) instruction. Or, the start point, end point, and border point were the same when the border point method was specified.	<ul style="list-style-type: none"> The start point and end point were the same when the radius method was specified for the MC_MoveCircular2D (Circular 2D Interpolation) instruction. The start point, end point, and border point were the same when the border point method was specified for the MC_MoveCircular2D (Circular 2D Interpolation) instruction. 				S		W502
54015449 hex	Circular Interpolation Center Specification Position Out of Range	The position specified for the center point exceeded the allowed range when the center method was specified for the MC_MoveCircular2D (Circular 2D Interpolation) instruction.	<ul style="list-style-type: none"> The difference between the distance from the start point to the center point and the distance between the end point to the center point exceeded the permitted value specified for the correction allowance ratio in the axes group settings when the center designation method was specified for the MC_MoveCircular2D (Circular 2D Interpolation) instruction. 				S		W502
5401544A hex	Instruction Execution Error Caused by Count Mode Setting	An instruction that cannot be used when the Count Mode is set to Rotary Mode was executed for an axis that was set to Rotary Mode.	<ul style="list-style-type: none"> An instruction that cannot be used when the Count Mode is set to Rotary Mode was executed for an axis that was set to Rotary Mode. 				S		W502
5401544C hex	Parameter Selection Out of Range	The parameter specified for the <i>ParameterNumber</i> input variable to a motion control instruction is out of range.	<ul style="list-style-type: none"> Instruction input parameter exceeded the valid range of the input variable. 				S		W502
5401544D hex	Stop Method Selection Out of Range	The parameter specified for the <i>StopMode</i> input variable to a motion control instruction is out of range.	<ul style="list-style-type: none"> Instruction input parameter exceeded the valid range of the input variable. 				S		W502
5401544E hex	Latch ID Selection Out of Range for Trigger Input Condition	The parameter specified for the <i>TriggerInput::LatchID</i> input variable to a motion control instruction is out of range.	<ul style="list-style-type: none"> Instruction input parameter exceeded the valid range of the input variable. 				S		W502
5401544F hex	Setting Out of Range for Writing MC Setting	The parameter specified for the <i>SettingValue</i> input variable to a motion control instruction is out of range.	<ul style="list-style-type: none"> Instruction input parameter exceeded the valid range of the input variable. The parameter specification and the data type of the setting value do not agree. 				S		W502

Event code	Event name	Meaning	Assumed cause	Level					Reference
				Maj	Prt	Min	Obs	Info	
54015450 hex	Trigger Input Condition Mode Selection Out of Range	The parameter specified for the <i>TriggerInput::Mode</i> input variable to a motion control instruction is out of range.	<ul style="list-style-type: none"> Instruction input parameter exceeded the valid range of the input variable. 				S		W502
54015451 hex	Drive Trigger Signal Selection Out of Range for Trigger Input Condition	The parameter specified for the <i>TriggerInput::Input-Drive</i> input variable to a motion control instruction is out of range.	<ul style="list-style-type: none"> Instruction input parameter exceeded the valid range of the input variable. 				S		W502
54015453 hex	Motion Control Instruction Re-execution Disabled (Axis Specification)	An attempt was made to change the parameter for the <i>Axis</i> input variable when re-executing a motion control instruction. (This input variable cannot be changed when re-executing an instruction.)	<ul style="list-style-type: none"> A parameter for an input variable that cannot be changed for re-execution was changed. 				S		W502
54015454 hex	Motion Control Instruction Re-execution Disabled (Buffer Mode Selection)	An attempt was made to change the parameter for the <i>BufferMode</i> input variable when re-executing a motion control instruction. (This input variable cannot be changed when re-executing an instruction.)	<ul style="list-style-type: none"> A parameter for an input variable that cannot be changed for re-execution was changed. 				S		W502
54015455 hex	Motion Control Instruction Re-execution Disabled (Direction Selection)	An attempt was made to change the parameter for the <i>Direction</i> input variable when re-executing a motion control instruction. (This input variable cannot be changed when re-executing an instruction.)	<ul style="list-style-type: none"> An input variable that cannot be changed for re-execution was changed. 				S		W502
54015456 hex	Motion Control Instruction Re-execution Disabled (Execution Mode)	An attempt was made to change the parameter for the <i>Periodic</i> input variable when re-executing a motion control instruction. (This input variable cannot be changed when re-executing an instruction.)	<ul style="list-style-type: none"> A parameter for an input variable that cannot be changed for re-execution was changed. 				S		W502
54015457 hex	Motion Control Instruction Re-execution Disabled (Axes Group Specification)	An attempt was made to change the parameter for the <i>AxesGroup</i> input variable when re-executing a motion control instruction. (This input variable cannot be changed when re-executing an instruction.)	<ul style="list-style-type: none"> A parameter for an input variable that cannot be changed for re-execution was changed. 				S		W502
54015458 hex	Motion Control Instruction Re-execution Disabled (Jerk Setting)	An attempt was made to change the parameter for the <i>Jerk</i> input variable when re-executing a motion control instruction. (This input variable cannot be changed when re-executing an instruction.)	<ul style="list-style-type: none"> A parameter for an input variable that cannot be changed for re-execution was changed. 				S		W502

Event code	Event name	Meaning	Assumed cause	Level					Reference
				Maj	Prt	Min	Obs	Info	
54015459 hex	Motion Control Instruction Re-execution Disabled (Master Axis)	An attempt was made to change the parameter for the <i>Master</i> input variable when re-executing a motion control instruction. (This input variable cannot be changed when re-executing an instruction.)	<ul style="list-style-type: none"> A parameter for an input variable that cannot be changed for re-execution was changed. 				S		W502
5401545A hex	Motion Control Instruction Re-execution Disabled (MasterOffset)	An attempt was made to change the parameter for the <i>MasterOffset</i> input variable when re-executing a motion control instruction. (This input variable cannot be changed when re-executing an instruction.)	<ul style="list-style-type: none"> A parameter for an input variable that cannot be changed for re-execution was changed. 				S		W502
5401545B hex	Motion Control Instruction Re-execution Disabled (MasterScaling)	An attempt was made to change the parameter for the <i>MasterScaling</i> input variable when re-executing a motion control instruction. (This input variable cannot be changed when re-executing an instruction.)	<ul style="list-style-type: none"> A parameter for an input variable that cannot be changed for re-execution was changed. 				S		W502
5401545C hex	Motion Control Instruction Re-execution Disabled (MasterStartDistance)	An attempt was made to change the parameter for the <i>MasterStartDistance</i> input variable when re-executing a motion control instruction. (This input variable cannot be changed when re-executing an instruction.)	<ul style="list-style-type: none"> A parameter for an input variable that cannot be changed for re-execution was changed. 				S		W502
5401545D hex	Motion Control Instruction Re-execution Disabled (Continuous)	An attempt was made to change the parameter for the <i>Continuous</i> input variable when re-executing a motion control instruction. (This input variable cannot be changed when re-executing an instruction.)	<ul style="list-style-type: none"> A parameter for an input variable that cannot be changed for re-execution was changed. 				S		W502
5401545E hex	Motion Control Instruction Re-execution Disabled (MoveMode)	An attempt was made to change the parameter for the <i>MoveMode</i> input variable when re-executing a motion control instruction. (This input variable cannot be changed when re-executing an instruction.)	<ul style="list-style-type: none"> A parameter for an input variable that cannot be changed for re-execution was changed. 				S		W502
5401545F hex	Illegal Auxiliary Axis Specification	The axis specified for the <i>Auxiliary</i> input variable to a motion control instruction does not exist.	<ul style="list-style-type: none"> An axis does not exist for the variable specified for the <i>Auxiliary</i> input variable to the instruction. 				S		W502
54015460 hex	Illegal Axis Specification	The axis specified for the <i>Axis</i> input variable to a motion control instruction does not exist.	<ul style="list-style-type: none"> An axis does not exist for the variable specified for the <i>Axis</i> input variable to the instruction. 				S		W502

Event code	Event name	Meaning	Assumed cause	Level					Refer- ence
				Maj	Prt	Min	Obs	Info	
54015461 hex	Illegal Axes Group Specification	The axes group specified for the <i>AxesGroup</i> input variable to a motion control instruction does not exist or is not a used group.	<ul style="list-style-type: none"> An axes group does not exist for the variable specified for the <i>AxesGroup</i> input variable to the instruction. The axes group specified for the <i>AxesGroup</i> input variable to the instruction is not specified as a used group. 				S		W502
54015462 hex	Illegal Master Axis Specification	The axis that is specified for the <i>Master</i> input variable to a motion control instruction is not correct.	<ul style="list-style-type: none"> An axis does not exist for the variable specified for the <i>Master</i> input variable to the instruction. The axis that was specified for the <i>Master</i> input variable to the MC_Phasing (Shift Master Axis Phase) instruction is not the master axis for syncing. The master axis and a slave axis are not assigned to the same task. 				S		W502
54015463 hex	Motion Control Instruction Re-execution Disabled (SlaveOffset)	An attempt was made to change the <i>SlaveOffset</i> input variable when re-executing a motion control instruction. (This input variable cannot be changed when re-executing an instruction.)	<ul style="list-style-type: none"> A parameter for an input variable that cannot be changed for re-execution was changed. 				S		W502
54015464 hex	Motion Control Instruction Re-execution Disabled (SlaveScaling)	An attempt was made to change the <i>SlaveScaling</i> input variable when re-executing a motion control instruction. (This input variable cannot be changed when re-executing an instruction.)	<ul style="list-style-type: none"> A parameter for an input variable that cannot be changed for re-execution was changed. 				S		W502
54015465 hex	Motion Control Instruction Re-execution Disabled (StartPosition)	An attempt was made to change the <i>StartPosition</i> input variable when re-executing a motion control instruction. (This input variable cannot be changed when re-executing an instruction.)	<ul style="list-style-type: none"> A parameter for an input variable that cannot be changed for re-execution was changed. 				S		W502

Event code	Event name	Meaning	Assumed cause	Level					Reference
				Maj	Prt	Min	Obs	Info	
54015466 hex	Instruction Execution Error with Undefined Home	High-speed homing or an interpolation instruction was executed when home was undefined.	<ul style="list-style-type: none"> High-speed homing was executed when home was undefined. An interpolation instruction was executed for an axes group that includes an axis with no defined home. One of the following robot instructions was executed for an axes group that includes a logical axis with no defined home. MC_SetKinTransform MC_MoveTimeAbsolute MC_SyncLinearConveyor MC_SyncOut MC_GroupMon MC_RobotJog 				S		W502
54015467 hex	Motion Control Instruction Re-execution Disabled (Position Type)	An attempt was made to change the <i>ReferenceType</i> input variable when re-executing a motion control instruction. (This input variable cannot be changed when re-executing an instruction.)	<ul style="list-style-type: none"> A parameter for an input variable that cannot be changed for re-execution was changed. 				S		W502
54015468 hex	Unused Axis Specification for Master Axis	The master axis specified for a motion control instruction is an unused axis.	<ul style="list-style-type: none"> The master axis specified for a motion control instruction is an unused axis. 				S		W502
54015469 hex	First Position Setting Out of Range	The parameter specified for the <i>FirstPosition</i> input variable to a motion control instruction is out of range.	<ul style="list-style-type: none"> Instruction input parameter exceeded the valid range of the input variable. 				S		W502
5401546A hex	Last Position Setting Out of Range	The parameter specified for the <i>LastPosition</i> input variable to a motion control instruction is out of range.	<ul style="list-style-type: none"> Instruction input parameter exceeded the valid range of the input variable. 				S		W502
5401546B hex	Illegal First/Last Position Size Relationship (Linear Mode)	The parameter specified for the <i>LastPosition</i> input variable to a motion control instruction is smaller than the parameter specified for the <i>FirstPosition</i> input variable.	<ul style="list-style-type: none"> The value of the <i>LastPosition</i> input parameter is less than the value of the <i>FirstPosition</i> input variable for the instruction when the Count Mode is set to Linear Mode. 				S		W502
5401546C hex	Master Sync Start Position Setting Out of Range	The parameter specified for the <i>MasterSyncPosition</i> input variable to a motion control instruction is out of range.	<ul style="list-style-type: none"> Instruction input parameter exceeded the valid range of the input variable. 				S		W502
5401546D hex	Slave Sync Start Position Setting Out of Range	The parameter specified for the <i>SlaveSyncPosition</i> input variable to a motion control instruction is out of range.	<ul style="list-style-type: none"> Instruction input parameter exceeded the valid range of the input variable. 				S		W502

Event code	Event name	Meaning	Assumed cause	Level					Reference
				Maj	Prt	Min	Obs	Info	
5401546E hex	Duplicate Latch ID for Trigger Input Condition	The same latch ID was specified for more than one motion control instruction.	<ul style="list-style-type: none"> The same latch ID is used simultaneously for more than one of the following instructions: MC_TouchProbe (Enable External Latch) instruction, MC_MoveLink (Synchronous Positioning) instruction, and MC_MoveFeed (Interrupt Feeding) instruction. The MC_AbortTrigger (Disable External Latch) instruction was executed to cancel a latch that was used by an instruction other than the MC_TouchProbe (Enable External Latch) instruction. 				S		W502
5401546F hex	Jerk Override Factor Out of Range	The parameter specified for the <i>JerkFactor</i> input variable to a motion control instruction is out of range.	<ul style="list-style-type: none"> Instruction input parameter exceeded the valid range of the input variable. 				S		W502
54015470 hex	Acceleration/Deceleration Override Factor Out of Range	The parameter specified for the <i>AccFactor</i> input variable to a motion control instruction is out of range.	<ul style="list-style-type: none"> Instruction input parameter exceeded the valid range of the input variable. 				S		W502
54015471 hex	First Position Method Specification Out of Range	The parameter specified for the <i>StartMode</i> input variable to a motion control instruction is out of range.	<ul style="list-style-type: none"> Instruction input parameter exceeded the valid range of the input variable. 				S		W502
54015472 hex	Motion Control Instruction Re-execution Disabled (First Position Method)	An attempt was made to change the <i>StartMode</i> input variable when re-executing a motion control instruction. (This input variable cannot be changed when re-executing an instruction.)	<ul style="list-style-type: none"> A parameter for an input variable that cannot be changed for re-execution was changed. 				S		W502
54015474 hex	Unused Axis Specification for Auxiliary Axis	The axis specified for the <i>Auxiliary</i> input variable to a motion control instruction is an unused axis.	<ul style="list-style-type: none"> The axis specified for the <i>Auxiliary</i> input variable to the instruction is an unused axis. 				S		W502
54015475 hex	Position Gear Value Error	Synchronized motion is not possible for the velocity, acceleration rate, and deceleration rate that were input to a motion control instruction.	<ul style="list-style-type: none"> The specified synchronized motion cannot be performed at the velocity, acceleration rate, or deceleration rate that is input to the instruction. 				S		W502
54015476 hex	Position Gear Master Axis Zero Velocity	The velocity of the master axis was zero when a motion control instruction was started.	<ul style="list-style-type: none"> The velocity of the master axis was 0 when the instruction was started. 				S		W502

Event code	Event name	Meaning	Assumed cause	Level					Reference
				Maj	Prt	Min	Obs	Info	
54015478 hex	Target Position Setting Out of Range	The parameter specified for the <i>Position</i> input variable to a motion control instruction is out of range.	<ul style="list-style-type: none"> Instruction input parameter exceeded the valid range of the input variable. The target position of a Rotary Mode axis is not within the ring setting range. 				S		W502
54015479 hex	Travel Distance Out of Range	The parameter that was specified for the <i>Distance</i> input variable to a motion control instruction is out of range or the target position with the value of <i>Distance</i> added is out of range.	<ul style="list-style-type: none"> The absolute value of the instruction input parameter exceeded the range of 40-bit data when it is converted to pulses. For a Linear Mode axis, the target position with the travel distance added exceeded signed 40-bit data when the absolute value is converted to pulses. 				S		W502
5401547A hex	Cam Table Start Point Setting Out of Range	The parameter specified for the <i>StartPosition</i> input variable to a motion control instruction is out of range.	<ul style="list-style-type: none"> Instruction input parameter exceeded the valid range of the input variable. 				S		W502
5401547B hex	Cam Master Axis Following First Position Setting Out of Range	The parameter specified for the <i>MasterStartDistance</i> input variable to a motion control instruction is out of range.	<ul style="list-style-type: none"> Instruction input parameter exceeded the valid range of the input variable. 				S		W502
5401547C hex	Circular Interpolation Radius Setting Error	It was not possible to create a circular path for the specified radius when the radius method was specified for the MC_MoveCircular2D (Circular 2D Interpolation) instruction.	<ul style="list-style-type: none"> For the MC_MoveCircular2D (Circular 2D Interpolation) instruction, it was not possible to create a circular path for the specified radius when the radius method was specified for circular interpolation. 				S		W502
5401547D hex	Circular Interpolation Radius Overflow	For the MC_MoveCircular2D (Circular 2D Interpolation) instruction, the radius of the circle exceeded the maximum value for the border point or center specification method.	<ul style="list-style-type: none"> For the MC_MoveCircular2D (Circular 2D Interpolation) instruction, the radius of the circle exceeded 40-bit data when converted to pulses for the border point or center specification method. 				S		W502
5401547E hex	Circular Interpolation Setting Out of Range	The parameter specified for the <i>CircAxes</i> input variable to a motion control instruction is out of range.	<ul style="list-style-type: none"> Instruction input parameter exceeded the valid range of the input variable. The axes that were specified in <i>CircAxes</i> are not included in the composition axes in the Axes Group Settings. The same axis was specified for both axes of <i>CircAxes</i>. 				S		W502

Event code	Event name	Meaning	Assumed cause	Level					Reference
				Maj	Prt	Min	Obs	Info	
5401547F hex	Auxiliary/Slave Axis Numbers Not in Ascending Order	The values of the parameters for the <i>Auxiliary</i> and <i>Slave</i> input variables to a motion control instruction are not in ascending order.	<ul style="list-style-type: none"> The parameters for the <i>Auxiliary</i> and <i>Slave</i> input variables to the instruction are not in ascending order. 				S		W502
54015480 hex	Cam Table Property Ascending Data Error at Update	A phase that was not in ascending order was found during calculating the number of valid data. Or, after calculations, the number of valid data is 0.	<ul style="list-style-type: none"> A phase that was not in ascending order was found when calculating the number of valid data. After calculations, the number of valid data is 0. 				S		W502
54015481 hex	MC_Write Target Out of Range	The parameter specified for the <i>Target</i> input variable to a motion control instruction is out of range.	<ul style="list-style-type: none"> Instruction input parameter exceeded the valid range of the input variable. 				S		W502
54015482 hex	Master Travel Distance Specification Out of Range	The parameter specified for the <i>MasterDistance</i> input variable to a motion control instruction is out of range.	<ul style="list-style-type: none"> Instruction input parameter exceeded the valid range of the input variable. 				S		W502
54015483 hex	Master Distance in Acceleration Specification Out of Range	The parameter specified for the <i>MasterDistanceACC</i> input variable to a motion control instruction is out of range.	<ul style="list-style-type: none"> Instruction input parameter exceeded the valid range of the input variable. 				S		W502
54015484 hex	Master Distance in Deceleration Specification Out of Range	The parameter specified for the <i>MasterDistanceDEC</i> input variable to a motion control instruction is out of range.	<ul style="list-style-type: none"> Instruction input parameter exceeded the valid range of the input variable. 				S		W502
54015487 hex	Execution Mode Selection Out of Range	The parameter specified for the <i>ExecutionMode</i> input variable to a motion control instruction is out of range.	<ul style="list-style-type: none"> Instruction input parameter exceeded the valid range of the input variable. 				S		W502
54015488 hex	Permitted Following Error Out of Range	The parameter specified for the <i>PermittedDeviation</i> input variable to a motion control instruction is out of range.	<ul style="list-style-type: none"> Instruction input parameter exceeded the valid range of the input variable. 				S		W502
54015489 hex	Border Point/Center Position/Radius Specification Out of Range	The parameter specified for the <i>AuxPoint</i> input variable to a motion control instruction is out of range.	<ul style="list-style-type: none"> The value of <i>AuxPoint</i> exceeded signed 40-bit data when converted to pulses for the border point or center specification method. For a radius specifications, the absolute value of <i>AuxPoint[0]</i> exceeded 40-bit data when converted to pulses. 				S		W502
5401548A hex	End Point Specification Out of Range	The parameter specified for the <i>EndPoint</i> input variable to a motion control instruction is out of range.	<ul style="list-style-type: none"> The instruction input parameter exceeded the range of signed 40-bit data when it is converted to pulses. 				S		W502

Event code	Event name	Meaning	Assumed cause	Level					Reference
				Maj	Prt	Min	Obs	Info	
5401548B hex	Slave Travel Distance Specification Out of Range	The parameter specified for the <i>SlaveDistance</i> input variable to a motion control instruction is out of range.	<ul style="list-style-type: none"> The instruction input parameter exceeded the range of 40-bit data when it is converted to pulses. 				S		W502
5401548C hex	Phase Shift Amount Out of Range	The parameter specified for the <i>PhaseShift</i> input variable to a motion control instruction is out of range.	<ul style="list-style-type: none"> The absolute value of the instruction input parameter exceeded the range of 40-bit data when it is converted to pulses. 				S		W502
5401548D hex	Feeding Distance Out of Range	The parameter specified for the <i>FeedDistance</i> input variable to a motion control instruction is out of range.	<ul style="list-style-type: none"> The absolute value of the instruction input parameter exceeded the range of 40-bit data when it is converted to pulses. 				S		W502
5401548E hex	Auxiliary and Slave Defined as Same Axis	The same axis was specified for the <i>Auxiliary</i> and <i>Slave</i> input variables to a motion control instruction.	<ul style="list-style-type: none"> The parameter is the same for the <i>Auxiliary</i> and <i>Slave</i> input variables to the instruction. 				S		W502
5401548F hex	Relative Position Selection Out of Range	The parameter specified for the <i>Relative</i> input variable to a motion control instruction is out of range.	<ul style="list-style-type: none"> Instruction input parameter exceeded the valid range of the input variable. 				S		W502
54015490 hex	Cam Transition Specification Out of Range	The parameter specified for the <i>CamTransition</i> input variable to a motion control instruction is out of range.	<ul style="list-style-type: none"> Instruction input parameter exceeded the valid range of the input variable. 				S		W502
54015491 hex	Synchronized Control End Mode Selection Out of Range	The parameter specified for the <i>OutMode</i> input variable to a motion control instruction is out of range.	<ul style="list-style-type: none"> Instruction input parameter exceeded the valid range of the input variable. 				S		W502
54015492 hex	Enable External Latch Instruction Execution Disabled	<i>_mclImmediateStop</i> was specified for the <i>StopMode</i> input variable when the <i>MC_TouchProbe</i> (Enable External Latch) instruction was executed in Drive Mode for an encoder axis.	<ul style="list-style-type: none"> <i>_mclImmediateStop</i> was specified for the <i>StopMode</i> input variable when the <i>MC_TouchProbe</i> (Enable External Latch) instruction was executed in Drive Mode for an encoder axis. 				S		W502
54015493 hex	Master Axis Offset Out of Range	The parameter specified for the <i>MasterOffset</i> input variable to a motion control instruction is out of range.	<ul style="list-style-type: none"> The instruction input parameter exceeded the range of signed 40-bit data when it is converted to pulses. 				S		W502
54015494 hex	Slave Axis Offset Out of Range	The parameter specified for the <i>SlaveOffset</i> input variable to a motion control instruction is out of range.	<ul style="list-style-type: none"> The instruction input parameter exceeded the range of signed 40-bit data when it is converted to pulses. 				S		W502
54015495 hex	Command Current Position Count Selection Out of Range	The parameter specified for the <i>CmdPosMode</i> input variable to a motion control instruction is out of range.	<ul style="list-style-type: none"> Instruction input parameter exceeded the valid range of the input variable. 				S		W502
54015496 hex	Master Axis Gear Ratio Numerator Out of Range	The parameter specified for the <i>RatioNumeratorMaster</i> input variable to a motion control instruction is out of range.	<ul style="list-style-type: none"> Instruction input parameter exceeded the valid range of the input variable. 				S		W502

Event code	Event name	Meaning	Assumed cause	Level					Refer- ence
				Maj	Prt	Min	Obs	Info	
54015497 hex	Master Axis Gear Ratio Denominator Out of Range	The parameter specified for the <i>RatioDenominatorMaster</i> input variable to a motion control instruction is out of range.	<ul style="list-style-type: none"> Instruction input parameter exceeded the valid range of the input variable. 				S		W502
54015498 hex	Auxiliary Axis Gear Ratio Numerator Out of Range	The parameter specified for the <i>RatioNumeratorAuxiliary</i> input variable to a motion control instruction is out of range.	<ul style="list-style-type: none"> Instruction input parameter exceeded the valid range of the input variable. 				S		W502
54015499 hex	Auxiliary Axis Gear Ratio Denominator Out of Range	The parameter specified for the <i>RatioDenominatorAuxiliary</i> input variable to a motion control instruction is out of range.	<ul style="list-style-type: none"> Instruction input parameter exceeded the valid range of the input variable. 				S		W502
5401549A hex	Master Axis Position Type Selection Out of Range	The parameter specified for the <i>ReferenceTypeMaster</i> input variable to a motion control instruction is out of range.	<ul style="list-style-type: none"> Instruction input parameter exceeded the valid range of the input variable. 				S		W502
5401549B hex	Auxiliary Axis Position Type Selection Out of Range	The parameter specified for the <i>ReferenceTypeAuxiliary</i> input variable to a motion control instruction is out of range.	<ul style="list-style-type: none"> Instruction input parameter exceeded the valid range of the input variable. 				S		W502
5401549C hex	Target Position Ring Counter Out of Range	Operation is not possible because the target position is out of range for the ring counter of the executed instruction.	<ul style="list-style-type: none"> High-speed homing was executed when 0 was not included in the ring counter. 				S		W502
5401549D hex (Ver. 1.01 or later)	Axes Group Composition Axis Setting Out of Range	The parameter specified for the <i>Axes</i> input variable to a motion control instruction is out of range.	<ul style="list-style-type: none"> Instruction input parameter exceeded the valid range of the input variable. The composition axes in the axes group are not assigned to the same task. 				S		W502
5401549E hex (Ver. 1.04 or later)	Axis Use Setting Out of Range	The parameter specified for the <i>AxisUse</i> input variable to a motion control instruction is out of range.	<ul style="list-style-type: none"> Instruction input parameter exceeded the valid range of the input variable. 				S		W502
54015700 hex (Ver. 1.03 or later)	Homing Parameter Setting Out of Range	The parameter specified for the <i>HomingParameter</i> input variable to a motion control instruction is out of range.	<ul style="list-style-type: none"> Instruction input parameter exceeded the valid range of the input variable. 				S		W502
54015702 hex (Ver. 1.04 or later)	Axis Use Change Error	The MC_ChangeAxisUse (Change Axis Use) instruction was executed when the axis was not stopped or when the command velocity of the axis was saturated.	<ul style="list-style-type: none"> The MC_ChangeAxisUse (Change Axis Use) instruction was executed when the axis was not stopped or when the command velocity of the axis was saturated. 				S		W502

Event code	Event name	Meaning	Assumed cause	Level					Reference
				Maj	Prt	Min	Obs	Info	
54015703 hex (Ver. 1.06 or later)	Cannot Change Axis Use	The MC_ChangeAxisUse (Change Axis Use) instruction was executed in a way that would cause the maximum number of used real axes or the maximum number of used motion control servo axes to be exceeded.	<ul style="list-style-type: none"> The MC_ChangeAxisUse (Change Axis Use) instruction was executed in a way that would cause the maximum number of used real axes to be exceeded. The MC_ChangeAxisUse (Change Axis Use) instruction was executed in a way that would cause the maximum number of used motion control servo axes to be exceeded. 				S		W502
54015720 hex (Ver. 1.04 or later)	Motion Control Parameter Setting Error When Changing Axis Use	The motion control parameter settings for the axis that was changed to a used axis are incorrect.	<ul style="list-style-type: none"> The MC_ChangeAxisUse (Change Axis Use) instruction was used to change an unused axis to a used axis, but the motion control parameter settings of the axis are not correct. The power supply was interrupted while a download of the motion control parameter settings was in progress. The non-volatile memory is faulty or the life of the non-volatile memory has been exceeded. 				S		W502
54015721 hex (Ver. 1.04 or later)	Required Process Data Object Not Set When Changing Axis Use	The objects that are required for the axis type of the axis that was changed to a used axis are not set.	<ul style="list-style-type: none"> The objects that are required for the axis type of the axis that was changed to a used axis are not set in the PDO map settings. The power supply was interrupted while a download of the motion control parameter settings was in progress. The non-volatile memory is faulty or the life of the non-volatile memory has been exceeded. The MC_ChangeAxisUse (Change Axis Use) instruction was executed for an axis that is set to <i>Unused axis (unchangeable to used axis)</i>. 				S		W502

3 Error Tables

Event code	Event name	Meaning	Assumed cause	Level					Reference
				Maj	Prt	Min	Obs	Info	
54015722 hex (Ver. 1.06 or later)	Actual Position Overflow/Underflow	An instruction was executed that is not supported during an actual position overflow/underflow.	<ul style="list-style-type: none"> An instruction was executed that is not supported during an actual position overflow or underflow. 				S		W502
54015723 hex (Ver. 1.06 or later)	Switch Structure Track Number Setting Out of Range	The value of <i>TrackNumber</i> that is specified in the <i>Switches</i> in-out variable to a motion control instruction is out of range.	<ul style="list-style-type: none"> The value of the member of the structure variable that was specified for the in-out variable of the instruction is out of range. 				S		W502
54015724 hex (Ver. 1.06 or later)	Switch Structure First ON Position Setting Out of Range	The value of <i>FirstOnPosition</i> that is specified in the <i>Switches</i> in-out variable to a motion control instruction is out of range.	<ul style="list-style-type: none"> The value of the member of the structure variable that was specified for the in-out variable of the instruction is out of range. 				S		W502
54015725 hex (Ver. 1.06 or later)	Switch Structure Last ON Position Setting Out of Range	The value of <i>LastOnPosition</i> that is specified in the <i>Switches</i> in-out variable to a motion control instruction is out of range.	<ul style="list-style-type: none"> The value of the member of the structure variable that was specified for the in-out variable of the instruction is out of range. 				S		W502
54015726 hex (Ver. 1.06 or later)	Switch Structure Axis Direction Out of Range	The value of <i>AxisDirection</i> that is specified in the <i>Switches</i> in-out variable to a motion control instruction is out of range.	<ul style="list-style-type: none"> The value of the member of the structure variable that was specified for the in-out variable of the instruction is out of range. 				S		W502
54015727 hex (Ver. 1.06 or later)	Switch Structure Cam Switch Mode Out of Range	The value of <i>CamSwitchMode</i> that is specified in the <i>Switches</i> in-out variable to a motion control instruction is out of range.	<ul style="list-style-type: none"> The value of the member of the structure variable that was specified for the in-out variable of the instruction is out of range. 				S		W502
54015728 hex (Ver. 1.06 or later)	Switch Structure Duration Setting Out of Range	The value of <i>Duration</i> that is specified in the <i>Switches</i> in-out variable to a motion control instruction is out of range.	<ul style="list-style-type: none"> The value of the member of the structure variable that was specified for the in-out variable of the instruction is out of range. 				S		W502
54015729 hex (Ver. 1.06 or later)	Track Option Structure ON Compensation Setting Out of Range	The value of <i>OnCompensation</i> that is specified in the <i>TrackOptions</i> in-out variable to a motion control instruction is out of range.	<ul style="list-style-type: none"> The value of the member of the structure variable that was specified for the in-out variable of the instruction is out of range. 				S		W502
5401572A hex (Ver. 1.06 or later)	Track Option Structure OFF Compensation Setting Out of Range	The value of <i>OffCompensation</i> that is specified in the <i>TrackOptions</i> in-out variable to a motion control instruction is out of range.	<ul style="list-style-type: none"> The value of the member of the structure variable that was specified for the in-out variable of the instruction is out of range. 				S		W502
5401572B hex (Ver. 1.06 or later)	Number of Array Elements in Switch Structure Variable Out of Range	The number of elements in an array in the structure variable that is specified in the <i>Switches</i> in-out variable to a motion control instruction is out of range.	<ul style="list-style-type: none"> The number of elements in an array of the structure variable that was specified for the in-out variable of the instruction is out of range. 				S		W502

Event code	Event name	Meaning	Assumed cause	Level					Reference
				Maj	Prt	Min	Obs	Info	
5401572C hex (Ver. 1.06 or later)	Number of Array Elements in Output Signal Structure Variable Out of Range	The number of elements in an array in the structure variable that is specified in the <i>Outputs</i> in-out variable to a motion control instruction is out of range.	<ul style="list-style-type: none"> The number of elements in an array of the structure variable that was specified for the in-out variable of the instruction is out of range. 				S		W502
5401572D hex (Ver. 1.06 or later)	Number of Array Elements in Track Option Structure Variable Out of Range	The number of elements in an array in the structure variable that is specified in the <i>TrackOptions</i> in-out variable to a motion control instruction is out of range.	<ul style="list-style-type: none"> The number of elements in an array of the structure variable that was specified for the in-out variable of the instruction is out of range. 				S		W502
5401572E hex (Ver. 1.06 or later)	Numbers of Elements in Output Signals and Track Option Arrays Not Matched	The arrays in the structure variables that are specified for the <i>Outputs</i> and <i>TrackOptions</i> in-out variables to a motion control instruction do not have the same number of elements.	<ul style="list-style-type: none"> The arrays in the output signal structure variable and track option structure variable that are specified for the in-out variables to the instruction do not have the same number of elements. 				S		W502
5401572F hex (Ver. 1.06 or later)	Motion Control Instruction Multi-execution Disabled (Master Axis)	A Master in-out variable that cannot be changed during multi-execution of instructions was changed.	<ul style="list-style-type: none"> A <i>Master</i> in-out variable that cannot be changed during multi-execution of instructions was changed. 				S		W502
54015730 hex (Ver. 1.06 or later)	Motion Control Instruction Multi-execution Disabled (Position Type Selection)	A <i>ReferenceType</i> in-out variable that cannot be changed during multi-execution of instructions was changed.	<ul style="list-style-type: none"> A <i>ReferenceType</i> in-out variable that cannot be changed during multi-execution of instructions was changed. 				S		W502
54015731 hex (Ver. 1.06 or later)	Same Track Number Setting in Switch Structure Out of Range	The same track number was specified more than the allowable number of times for the <i>TrackNumber</i> in the <i>Switches</i> in-out variable to a motion control instruction.	<ul style="list-style-type: none"> The same track number was specified more than the allowable number of times for the <i>TrackNumber</i> in the <i>Switches</i> in-out variable to a motion control instruction. 				S		W502
5401573A hex (Ver. 1.08 or later)	Cannot Write Axis Parameters	The instruction was executed for an axis that is not an unused axis.	<ul style="list-style-type: none"> The instruction was executed for a used axis or an undefined axis. 				S		W502
5401573B hex (Ver. 1.08 or later)	Axis Parameter Setting Out of Range	The parameter specified for the <i>AxisParameter</i> input variable to a motion control instruction is outside of the valid range.	<ul style="list-style-type: none"> The parameter specified for the <i>AxisParameter</i> input variable to the instruction is out of range for the input variable. 				S		W502
5401573C hex (Ver. 1.08 or later)	Cam Property Setting Out of Range	The parameter specified for the <i>CamProperty</i> input variable to a motion control instruction is outside of the valid range.	<ul style="list-style-type: none"> The parameter specified for the <i>CamProperty</i> input variable to the instruction is out of range for the input variable. 				S		W502
5401573D hex (Ver. 1.08 or later)	Cam Node Setting Out of Range	The parameter specified for the <i>CamNodes</i> input variable to a motion control instruction is outside of the valid range.	<ul style="list-style-type: none"> The parameter specified for the <i>CamNodes</i> input variable to the instruction is out of range for the input variable. 				S		W502

Event code	Event name	Meaning	Assumed cause	Level					Reference
				Maj	Prt	Min	Obs	Info	
5401573E hex (Ver. 1.08 or later)	Incorrect Cam Node Type Specification	The parameter specified for the <i>CamNodes</i> input variable to a motion control instruction is not an <i>_sMC_CAM_NODE</i> array variable.	<ul style="list-style-type: none"> The parameter specified for the <i>CamNodes</i> input variable to the instruction is not an <i>_sMC_CAM_NODE</i> array variable. 				S		W502
5401573F hex (Ver. 1.08 or later)	Insufficient Nodes in Cam Table	The array variable of the parameter specified for the <i>CamNodes</i> input variable to a motion control instruction has a <i>Phase</i> value of 0 for element number 0.	<ul style="list-style-type: none"> The array variable of the parameter specified for the <i>CamNodes</i> input variable to the instruction has a <i>Phase</i> (master axis phase) value of 0 for element number 0. 				S		W502
54015740 hex (Ver. 1.08 or later)	Cam Node Master Axis Phase Not in Ascending Order	The values of <i>Phase</i> in the array variable of the parameter specified for the <i>CamNodes</i> input variable to a motion control instruction are not in ascending order according to the element numbers.	<ul style="list-style-type: none"> The values of <i>Phase</i> (master axis phase) in the array variable of the parameter specified for the <i>CamNodes</i> input variable to the instruction are not in ascending order according to the element numbers. Or, truncating the digits that are not effective more than seven digits caused the phases to not be in ascending order. 				S		W502
54015741 hex (Ver. 1.08 or later)	Too Many Data Points in Cam Table	The number of generated cam data points exceeded the number of elements in the array in the cam data variable that is specified for the <i>CamTable</i> input variable to a motion control instruction.	The number of cam data points in the generated cam table exceeded the number of elements in the array in the cam data variable that is specified for the <i>CamTable</i> input variable to the instruction.				S		W502
54015742 hex (Ver. 1.08 or later)	Cam Table Displacement Overflow	<i>Distance</i> in the generated cam table exceeded the range of REAL data.	<ul style="list-style-type: none"> <i>Distance</i> in the generated cam table exceeded the range of REAL data. 				S		W502
54015743 hex (Ver. 1.08 or later)	Aborted Cam Table Used	A cam data variable that was aborted during generation was specified for the <i>CamTable</i> input variable to an instruction.	<ul style="list-style-type: none"> A cam data variable that was aborted during generation due to an error in the <i>MC_GenerateCamTable</i> (Generate Cam Table) instruction was specified for the <i>CamTable</i> input variable to the instruction. 				S		W502
54015749 hex (Ver. 1.10 or later)	Execution ID Setting Out of Range	The parameter specified for the <i>ExecID</i> input variable to a motion control instruction is out of range.	<ul style="list-style-type: none"> The parameter specified for the <i>ExecID</i> input variable to the instruction is out of range for the input variable. 				S		W502
5401574A hex (Ver. 1.10 or later)	Position Offset Out of Range	The parameter specified for the <i>OffsetPosition</i> input variable to a motion control instruction is out of range.	<ul style="list-style-type: none"> The position offset exceeded the range of signed 40-bit data when it was converted to pulses. 				S		W502

Event code	Event name	Meaning	Assumed cause	Level					Reference
				Maj	Prt	Min	Obs	Info	
5401574B hex (Ver. 1.10 or later)	PDS State Transition Command Selection Out of Range	The parameter specified for the <i>TransitionCmd</i> input variable to a motion control instruction is out of range.	<ul style="list-style-type: none"> Instruction input parameter exceeded the valid range of the input variable. 				S		W502
5401574C hex (Ver. 1.13 or later)	Single-axis Position Control Axis Motion Control Instruction Execution Disabled	An operation instruction was executed for a single-axis position control axis.	<ul style="list-style-type: none"> An operation instruction was executed for a single-axis position control axis. 				S		W502
54016440 hex	Target Position Positive Software Limit Exceeded	The specified position exceeds the positive software limit.	<ul style="list-style-type: none"> The parameter specified for the <i>Position</i> input variable to the instruction is beyond the positive software limit. The first position is beyond the positive software limit and an instruction that specifies motion in the opposite direction of the software limit was executed. The parameter that was specified for the <i>AuxPoint</i> input variable to a border point MC_MoveCircular2D (Circular 2D Interpolation) instruction is beyond the positive software limit. 				S		W502
54016441 hex	Target Position Negative Software Limit Exceeded	The specified position exceeds the negative software limit.	<ul style="list-style-type: none"> The parameter specified for the <i>Position</i> input variable to the instruction is beyond the negative software limit. The first position is beyond the negative software limit and an instruction that specifies motion in the opposite direction of the software limit was executed. The parameter that was specified for the <i>AuxPoint</i> input variable to a border point MC_MoveCircular2D (Circular 2D Interpolation) instruction is beyond the negative software limit. 				S		W502

Event code	Event name	Meaning	Assumed cause	Level					Reference
				Maj	Prt	Min	Obs	Info	
54016442 hex	Command Position Overflow/Underflow	Positioning, an instruction in the underflow/overflow direction, or an instruction for which the direction is not specified was executed when there was an underflow/overflow in the command position.	<ul style="list-style-type: none"> One of the following was executed when there was a command position overflow/underflow. <ul style="list-style-type: none"> A positioning instruction A continuous control instruction in the underflow/overflow direction An instruction for which the direction is not specified (syncing or torque control) 				S		W502
54016443 hex	Positive Limit Input	An instruction was executed for a motion in the positive direction when the positive limit input was ON.	<ul style="list-style-type: none"> An instruction for a motion in the positive direction was executed when the positive limit input was ON, or an instruction for a motion with no direction specification was executed when the positive limit input was ON. An axes group motion control instruction was executed when the positive limit input was ON. 				S		W502
54016444 hex	Negative Limit Input	An instruction for a motion in the negative direction was executed when the negative limit input was ON.	<ul style="list-style-type: none"> An instruction for a motion in the negative direction was executed when the negative limit input was ON, or an instruction for a motion with no direction specification was executed when the negative limit input was ON. An axes group motion control instruction was executed when the negative limit input was ON. 				S		W502
54017422 hex	Servo Main Circuits OFF	An attempt was made to turn ON the Servo when the main circuit power supply to the Servo Drive was OFF.	<ul style="list-style-type: none"> An attempt was made to turn ON the Servo when the main circuit power supply to the Servo Drive was OFF. 				S		W502

3-1-3 Errors in the NX Bus Function Module

The section provides tables of the errors (events) that can occur in the NX Bus Function Module.

Errors Related to the NX Bus

The manual names are given below for the catalog numbers given in the *Reference* column of the event table.

Cat. No.	Manual name
W501	NJ/NX-series CPU Unit Software User's Manual
W578	NX-series NX1P2 CPU Unit Hardware User's Manual

With the NX1P2 CPU Unit, two or more events with more specific names may correspond to one Slave Terminal event. Refer to *A-2 Correspondence of NX Bus Events between NX1P2 CPU Units and Slave Terminals* for details.

Event code	Event name	Meaning	Assumed cause	Level					Reference
				Maj	Prt	Min	Obs	Info	
04100000 hex (Ver. 1.13 or later)	NX Bus Controller Error	An error occurred in the NX bus.	<ul style="list-style-type: none"> An I/O communications error occurred between the CPU Unit and the NX Unit. 		S				W501, W578
04110000 hex (Ver. 1.13 or later)	NX Bus Hardware Error	A hardware error was detected in the NX Bus Function Module.	<ul style="list-style-type: none"> A hardware error related to the NX bus was detected. 		S				W501, W578
10600000 hex (Ver. 1.13 or later)	NX Bus Memory Check Error	An error was detected in the internal memory check for the NX Bus Function Module.	<ul style="list-style-type: none"> An error was detected in the memory check for the internal protection circuit. 		S				W501, W578
10610000 hex (Ver. 1.13 or later)	Failed to Read NX Unit Operation Settings	Reading the NX Unit operation settings failed. Cycle the power supply to the CPU Unit to restore the previous normally-saved settings.	<ul style="list-style-type: none"> The NX Unit operation settings are not saved normally in the CPU Unit. 		S				W501, W578
24D00000 hex (Ver. 1.13 or later)	Number of Mountable NX Units Exceeded	The number of mounted NX Units exceeds the specified value for the CPU Unit.	<ul style="list-style-type: none"> More than the maximum number of NX Units are mounted on the CPU Unit. 		S				W501, W578
24D20000 hex (Ver. 1.13 or later)	Total I/O Data Size in NX Units Excessive	The total size of I/O data in the mounted NX Units exceeds the maximum specified value for the CPU Unit.	<ul style="list-style-type: none"> The total size of I/O data in the mounted NX Units exceeds the maximum specified value for the CPU Unit. 		S				W501, W578
35900000 hex (Ver. 1.13 or later)	NX Unit Version Not Matched	There is a mounted NX Unit with a unit version earlier than that in the Unit configuration information registered in the CPU Unit.	<ul style="list-style-type: none"> The unit version of an NX Unit mounted in the actual configuration is earlier than that in the Unit configuration information registered in the CPU Unit. 		S				W501, W578

Event code	Event name	Meaning	Assumed cause	Level					Reference
				Maj	Prt	Min	Obs	Info	
35910000 hex (Ver. 1.13 or later)	Unregistered NX Unit Mounted	There is a mounted NX Unit that does not exist in the Unit configuration information registered in the CPU Unit. If there are more than one NX Unit relevant to this event, only the NX Unit that is nearest to the CPU Unit is registered with the event.	<ul style="list-style-type: none"> There is a mounted Unit that does not exist in the Unit configuration information registered in the CPU Unit. There is a mounted Unit in which the NX Unit Mounting Setting is set to <i>Disabled</i>. 		S				W501, W578
35930000 hex (Ver. 1.13 or later)	NX Unit Serial Number Mismatch	There is a mounted NX Unit with a serial number different from that in the Unit configuration information registered in the CPU Unit.	<ul style="list-style-type: none"> There is no mounted NX Unit with the serial number that you set in the Unit configuration information registered in the CPU Unit. 		S				W501, W578
44440000 hex (Ver. 1.13 or later)	NX Bus Function Processing Error	A fatal error was detected in the NX Bus Function Module.	<ul style="list-style-type: none"> An error occurred in the software. 		S				W501, W578
85540000 hex (Ver. 1.13 or later)	NX Bus I/O Communications Stopped Due to Another Event	The I/O communications on the NX bus were stopped based on the Fail-soft Operation Setting because an error that triggers fail-soft operation occurred.	<ul style="list-style-type: none"> I/O refreshing was stopped based on the Fail-soft Operation Setting. 		S				W501, W578
35920000 hex (Ver. 1.13 or later)	Registered NX Unit Not Mounted	There is no mounted NX Unit that exists in the Unit configuration information registered in the CPU Unit. If there are more than one NX Unit relevant to this event, only the NX Unit that is nearest to the CPU Unit is registered with the event.	<ul style="list-style-type: none"> There is no mounted NX Unit that exists in the Unit configuration information registered in the CPU Unit. The power supply to the Additional NX Unit Power Supply Unit is not turned ON. 			S			W501, W578
85500000 hex (Ver. 1.13 or later)	NX Bus Communications Error	A communications error that prevents normal NX bus communications was detected. If there are more than one NX Unit relevant to this event, only the NX Unit that is nearest to the CPU Unit is registered with the event.	<ul style="list-style-type: none"> The NX bus connector contact is faulty due to vibration or shock. Excessive noise is applied to the NX bus connector. An NX Unit was removed. An error occurred in an NX Unit. 			S			W501, W578

Event code	Event name	Meaning	Assumed cause	Level					Reference
				Maj	Prt	Min	Obs	Info	
85510000 hex (Ver. 1.13 or later)	NX Unit Communications Timeout	An error occurred in I/O data communications with the NX Units.	<ul style="list-style-type: none"> An NX Bus Communications Error has occurred. An error occurred in an NX Unit. 			S			W501, W578
85520000 hex (Ver. 1.13 or later)	NX Unit Initialization Error	Initializing an NX Unit failed.	<ul style="list-style-type: none"> Initialization with the Unit configuration information registered in the CPU Unit failed. An NX Bus Communications Error has occurred. The Channel Enable/Disable Setting for all channels of the Analog Unit are set to <i>Disable</i>. Initialization of an NX Unit failed. 			S			W501, W578
85530000 hex (Ver. 1.13 or later)	NX Unit Startup Error	Starting an NX Unit failed.	<ul style="list-style-type: none"> A startup error occurred in an NX Unit. 			S			W501, W578
103C0000 hex (Ver. 1.13 or later)	NX Unit Backup Failed	The backup operation for an NX Unit ended in an error.	<ul style="list-style-type: none"> There is also another error related to the NX Bus Function Module. An NX Bus Communications Error has occurred. Backup data cannot be received from an NX Unit. 				S		W501, W578
103D0000 hex (Ver. 1.13 or later)	NX Unit Restore Operation Failed	The restore operation for an NX Unit ended in an error.	<ul style="list-style-type: none"> There is also another error related to the NX Bus Function Module. An NX Bus Communications Error has occurred. The backup data cannot be sent to an NX Unit. The Unit configuration in the backup file does not agree with the actual Unit configuration. 				S		W501, W578
10620000 hex (Ver. 1.13 or later)	NX Unit Event Log Save Error	Saving or reading the NX Unit event log failed. Continuing to operate with this error may result in no event log saved at CPU Unit power OFF although it has no effect on the control function.	<ul style="list-style-type: none"> Data in the NX Unit event log area are invalid. 				S		W501, W578
44450000 hex (Ver. 1.13 or later)	NX Bus System Information	This event provides internal information from the NX Bus Function Module.	<ul style="list-style-type: none"> This event provides internal information from the NX Bus Function Module. 					S	W501, W578
95800000 hex (Ver. 1.13 or later)	NX Bus Restart Executed	An NX bus restart was executed.	<ul style="list-style-type: none"> An NX bus restart command was received. 					S	W501, W578

3-1-4 Errors in the Motion Control Function Module

The section provides tables of the errors (events) that can occur in the Motion Control Function Module. They are divided into the following functional classifications.

- General motion control
- Motion control instructions

Motion control instruction errors occur when a motion control instruction is executed. Notification of these errors is provided as events, but also the upper four digits of the event code is output to the *ErrorID* output variable of the motion control instruction and to the **Lvl.Code* system-defined variable for motion control.

General Motion Control

The manual names are given below for the catalog numbers given in the *Reference* column of the event table.

Cat. No.	Manual name
W507	NJ/NX-series CPU Unit Motion Control User's Manual

Event code	Event name	Meaning	Assumed cause	Level					Reference
				Maj	Prt	Min	Obs	Info	
44210000 hex	Motion Control Function Processing Error	A fatal error was detected in the Motion Control Function Module.	<ul style="list-style-type: none"> An error occurred in the software. 	S					W507
14600000 hex	Absolute Encoder Home Offset Read Error	The absolute encoder current position that is retained during power interruptions was lost.	<ul style="list-style-type: none"> When the retained variables are backed up with a battery, this event indicates that the life of the battery in the CPU Unit has expired. An error occurred in the software. Backup memory failure 		S				W507
14610000 hex	Motion Control Parameter Setting Error	The MC parameters that were saved in non-volatile memory are missing.	<ul style="list-style-type: none"> The power supply to the Controller was interrupted or communications with the Sysmac Studio were disconnected while downloading the motion control parameter settings or clearing memory. Non-volatile memory failure 		S				W507
14620000 hex	Cam Data Read Error	The cam data that was saved in non-volatile memory is missing.	<ul style="list-style-type: none"> Power was interrupted during save processing for cam data Non-volatile memory failure 		S				W507
34600000 hex	Required Process Data Object Not Set	The object that is required for the axis type is not allocated to PDO.	<ul style="list-style-type: none"> The required PDOs are not mapped when the axis type is set to a servo axis or encoder axis. Non-volatile memory failure 		S				W507
34630000 hex	Axis Slave Disabled	The slave to which the axis is assigned is disabled.	<ul style="list-style-type: none"> The slave to which the axis is assigned is disabled. 		S				W507
34640000 hex	Network Configuration Information Missing for Axis Slave	The network configuration information is not registered for the slave to which the axis is assigned.	<ul style="list-style-type: none"> The EtherCAT network configuration information is not registered for the slave to which the axis is assigned. 		S				W507

Event code	Event name	Meaning	Assumed cause	Level					Reference
				Maj	Prt	Min	Obs	Info	
44200000 hex	Motion Control Initialization Error	A fatal error occurred in the system and prevented initialization of the Motion Control Function Module.	<ul style="list-style-type: none"> Hardware has failed. 		S				W507
74200000 hex	Motion Control Period Exceeded	Processing for the primary periodic task was not finished within two control periods.	<ul style="list-style-type: none"> The processing load in the primary periodic task is too heavy. 		S				W507
14630000 hex	Cam Table Save Error	Saving a cam table to a file failed.	<ul style="list-style-type: none"> Saving a cam table to a file failed. 			S			W507
54770000 hex	Cam Table Data Error during Cam Motion	The phases are not in ascending order in the cam table.	<ul style="list-style-type: none"> Data containing cam table phases that are not in ascending order was detected during cam motion. The phase and displacement of the start point in the cam table were not 0 during cam operation. The phase of the end point in the cam table when converted to pulses was not 1 pulse or greater during cam operation. 			S			W507
54850000 hex	Immediate Stop Instruction Executed	An Immediate Stop (MC_ImmediateStop) instruction was executed.	<ul style="list-style-type: none"> An Immediate Stop instruction was executed. 			S			W507
54860000 hex	Axes Group Immediate Stop Instruction Executed	An Axes Group Immediate Stop (MC_GroupImmediateStop) instruction was executed.	<ul style="list-style-type: none"> A Group Immediate Stop instruction was executed. 			S			W507
64450000 hex	Positive Software Limit Exceeded	The position exceeded the positive software limit while the axis is in motion.	<ul style="list-style-type: none"> The position exceeded the positive software limit. 			S			W507
64460000 hex	Negative Software Limit Exceeded	The position exceeded the negative software limit while the axis is in motion.	<ul style="list-style-type: none"> The position exceeded the negative software limit. 			S			W507
64470000 hex	In-position Check Time Exceeded	The in-position check was not completed within the monitoring time.	<ul style="list-style-type: none"> Time is required to complete positioning. 			S			W507
64480000 hex	Following Error Limit Exceeded	The error between the command current position and actual current value exceeded the Following Error Over Limit Value.	<ul style="list-style-type: none"> The positioning operation has poor following performance and the actual motion is slower than the command. 			S			W507
64490000 hex	Immediate Stop Input	The immediate stop input turned ON.	<ul style="list-style-type: none"> An immediate stop input signal was detected. The immediate stop input signal is not connected correctly or the logic setting for the immediate stop input is wrong. 			S			W507

Event code	Event name	Meaning	Assumed cause	Level					Reference
				Maj	Prt	Min	Obs	Info	
644A0000 hex	Positive Limit Input Detected	The positive limit input turned ON.	<ul style="list-style-type: none"> A positive limit input signal was detected. The positive limit input signal is not connected correctly or the logic setting for the positive limit input is wrong. 			S			W507
644B0000 hex	Negative Limit Input Detected	The negative limit input turned ON.	<ul style="list-style-type: none"> A negative limit input signal was detected. The negative limit input signal is not connected correctly or the logic setting for the negative limit input is wrong. 			S			W507
64560000 hex	Illegal Following Error	The difference between the command position and the actual current position exceeds the range of 30-bit data when converted to pulses.	<ul style="list-style-type: none"> The command current position was restricted so that the axis velocity of the slave axis would not exceed the axis maximum velocity for the specified travel distance. Performance of slave axis positioning operation is poor and the actual motion is slower than the command. 			S			W507
64570000 hex	Servo OFF Error	The Servo was turned OFF for an axis due to an axes group error.	<ul style="list-style-type: none"> The Servo was turned OFF for an axis due to an axes group error. 			S			W507
64580000 hex	Absolute Encoder Current Position Calculation Failed	It was not possible to correctly restore the current position from the absolute encoder information that was saved when power was interrupted.	<ul style="list-style-type: none"> The unit conversion settings, the ring counter setting in the Controller, or the ring counter setting in the Servo Drive settings was changed. The position to restore when converted to pulses exceeded the range of signed 40-bit data. 			S			W507
64590000 hex	Home Undefined during Coordinated Motion	Home of the logical axis became undefined during axes group motion or while decelerating to a stop.	<ul style="list-style-type: none"> The command position or actual position overflowed or underflowed for a logical axis in an axes group motion or a logical axis that was decelerating to a stop and the home definition was lost. A slave communications error occurred for a logical axis and home became undefined during axes group motion or while decelerating to a stop. A slave for a logical axis left the network or was disabled and home became undefined during axes group motion or while decelerating to a stop. 			S			W507
74210000 hex	Servo Main Circuit Power OFF	The main circuit power of the Servo Drive turned OFF while the Servo was ON.	<ul style="list-style-type: none"> The main circuit power of the Servo Drive was interrupted while the Servo was ON. 			S			W507
74230000 hex	Interrupt Feeding Interrupt Signal Missing	An interrupt input was not received during execution of an MC_MoveFeed (Interrupt Feeding) instruction.	<ul style="list-style-type: none"> The latch enabled range specification is invalid. There is a problem with the wiring of the interrupt signal. The sensor that outputs the interrupt signal has failed. 			S			W507

Event code	Event name	Meaning	Assumed cause	Level					Reference
				Maj	Prt	Min	Obs	Info	
74240000 hex	Homing Opposite Direction Limit Input Detected	The limit signal in the direction opposite to the homing direction was detected during a homing operation.	<ul style="list-style-type: none"> The Operation Selection at Negative Limit Input or Operation Selection at Positive Limit Input parameter is set to <i>No reverse turn</i>. The location of the homing input signal sensors, homing settings, and homing start position cause a limit input to be reached. The input signal sensor wiring is incorrect or the sensor is faulty. 			S			W507
74250000 hex	Homing Direction Limit Input Detected	The limit signal in the homing direction was detected during a homing operation.	<ul style="list-style-type: none"> The Operation Selection at Negative Limit Input or Operation Selection at Positive Limit Input parameter is set to <i>No reverse turn</i>. The location of the homing input signal sensors, homing settings, and homing start position cause a limit input to be reached. The input signal sensor wiring is incorrect or the sensor is faulty. 			S			W507
74260000 hex	Homing Limit Inputs Detected in Both Directions	The limit signals in both directions were detected during a homing operation.	<ul style="list-style-type: none"> The wiring of the limit signal is incorrect. The limit sensor is installed in the wrong location. The contact logic of the limit signal is not correct. The limit sensor failed. 			S			W507
74270000 hex	Home Proximity/Homing Opposite Direction Limit Input Detected	The home proximity input and the limit signal in the direction opposite to the homing direction were detected during a homing operation.	<ul style="list-style-type: none"> The wiring of the home proximity signal or limit signal is incorrect. The home proximity sensor or limit sensor is installed in the wrong location. The contact logic of the home proximity signal or limit signal is not correct. The home proximity sensor or limit sensor failed. 			S			W507
74280000 hex	Home Proximity/Homing Direction Limit Input Detected	The home proximity input and the limit signal in the homing direction were detected at the same time during a homing operation.	<ul style="list-style-type: none"> The wiring of the home proximity signal or limit signal is incorrect. The home proximity sensor or limit sensor is installed in the wrong location. The contact logic of the home proximity signal or limit signal is not correct. The home proximity sensor or limit sensor failed. 			S			W507

Event code	Event name	Meaning	Assumed cause	Level					Reference
				Maj	Prt	Min	Obs	Info	
74290000 hex	Home Input/Homing Opposite Direction Limit Input Detected	The home input and the limit signal in the direction opposite to the homing direction were detected at the same time during a homing operation.	<ul style="list-style-type: none"> The wiring of the home input signal or limit signal is incorrect. The home input sensor or limit sensor is installed in the wrong location. The contact logic of the home input signal or limit signal is not correct. The home input signal output device or limit sensor failed. 			S			W507
742A0000 hex	Home Input/Homing Direction Limit Input Detected	The home input and the limit signal in the homing direction were detected at the same time during a homing operation.	<ul style="list-style-type: none"> The wiring of the home input signal or limit signal is incorrect. The home input sensor or limit sensor is installed in the wrong location. The contact logic of the home input signal or limit signal is not correct. The home input signal output device or limit sensor failed. 			S			W507
742B0000 hex	Invalid Home Input Mask Distance	The setting of the home input mask distance is not suitable for the MC_Home or MC_HomeWithParameter instruction.	<ul style="list-style-type: none"> The set value of the home input mask distance when the operating mode of the MC_Home instruction is set to <i>Proximity Reverse Turn/Home Input Mask Distance</i> is insufficient to decelerate from the homing velocity to the homing approach velocity. 			S			W507
742C0000 hex	No Home Input	There was no home signal input during the homing operation. Or, a limit signal was detected before there was a home input.	<ul style="list-style-type: none"> There was no home signal input during the homing operation. A limit signal was detected before there was a home input. 			S			W507
742D0000 hex	No Home Proximity Input	There was no home proximity signal input during the homing operation.	<ul style="list-style-type: none"> There was no home proximity signal input during the homing operation when a home proximity input signal was specified. 			S			W507
742F0000 hex	Slave Error Detected	An error was detected for the EtherCAT slave or NX Unit that is allocated to an axis.	<ul style="list-style-type: none"> An error was detected for the EtherCAT slave or NX Unit that is allocated to an axis. 			S			W507
74300000 hex	Axes Group Composition Axis Error	An error occurred for an axis in an axes group.	<ul style="list-style-type: none"> An error occurred for an axis in an axes group that was in motion. 			S			W507
74330000 hex	MC Common Error Occurrence	An MC common error occurred.	<ul style="list-style-type: none"> Partial fault level MC common error occurred. 			S			W507
74340000 hex	Latch Position Overflow	An overflow occurred for the latched position for the MC_TouchProbe (Enable External Latch) instruction.	<ul style="list-style-type: none"> An overflow occurred for the latched position for the MC_TouchProbe (Enable External Latch) instruction. 			S			W507

Event code	Event name	Meaning	Assumed cause	Level					Reference
				Maj	Prt	Min	Obs	Info	
74350000 hex	Latch Position Underflow	An underflow occurred for the latched position for the MC_TouchProbe (Enable External Latch) instruction.	<ul style="list-style-type: none"> An underflow occurred for the latched position for the MC_TouchProbe (Enable External Latch) instruction. 			S			W507
74360000 hex	Master Sync Direction Error	The master axis continued to move in the direction opposite to the sync direction.	<ul style="list-style-type: none"> The master axis continued to move in the direction opposite to the sync direction of the master and slave axes, resulting in an overflow. 			S			W507
74370000 hex	Slave Disconnection during Servo ON	One of the following occurred while the Servo was ON for the EtherCAT slave or NX Unit that is allocated to an axis. <ul style="list-style-type: none"> Disconnection or replacement Disabling Restart of the NX bus on the NX-series CPU Unit 	One of the following occurred while the Servo was ON for the EtherCAT slave or NX Unit that is allocated to an axis. <ul style="list-style-type: none"> Disconnection or replacement Disabling Restart of the NX bus on the NX-series CPU Unit 			S			W507
74380000 hex	Feed Distance Overflow	The target position after the interrupt input was received for the MC_MoveFeed (Interrupt Feeding) instruction overflowed or underflowed.	<ul style="list-style-type: none"> The target position after the interrupt input was received for the MC_MoveFeed (Interrupt Feeding) instruction exceeded the range of signed 40-bit data when converted to pulses. 			S			W507
74390000 hex	Error in Changing Servo Drive Control Mode	Changing the Control Mode was not completed within the specified time.	<ul style="list-style-type: none"> When the MC_SyncMoveVelocity instruction was stopped, the actual current velocity was not reduced to 10% or less of the maximum velocity within 10 seconds for three consecutive periods after a command velocity of 0 was output. For an OMRON 1S-series Servo Drive or G5-series Servo Drive, the actual current velocity was not reduced to 10% or less of the maximum velocity within 10 seconds for three consecutive periods when the MC_TorqueControl instruction was stopped. Changing the Control Mode of the Servo Drive between CSP, CSV, and CST was not completed within one second after the command was executed. 			S			W507

Event code	Event name	Meaning	Assumed cause	Level					Reference
				Maj	Prt	Min	Obs	Info	
743A0000 hex	Master Axis Position Read Error	The synchronized control instruction was not executed because an error occurred in the position of the master axis of the synchronized control instruction.	<ul style="list-style-type: none"> EtherCAT process data communications are not established for the master axis of the synchronized control instruction or the I/O data of the NX Unit cannot be used for control. The slave of the master axis for the synchronized control instruction was disconnected or disabled. An Absolute Encoder Current Position Calculation Failed error (64580000 hex) was detected for the master axis of the synchronized control instruction. The master axis for the synchronized control instruction is an unused axis. 			S			W507
743B0000 hex	Auxiliary Axis Position Read Error	The synchronized control instruction was not executed because an error occurred in the position of the auxiliary axis of the synchronized control instruction.	<ul style="list-style-type: none"> EtherCAT process data communications are not established for the auxiliary axis of the synchronized control instruction or the I/O data of the NX Unit cannot be used for control. The slave of the auxiliary axis for the synchronized control instruction was disconnected or disabled. An Absolute Encoder Current Position Calculation Failed error (64580000 hex) was detected for the auxiliary axis of the synchronized control instruction. The auxiliary axis for the synchronized control instruction is an unused axis. 			S			W507
84400000 hex	EtherCAT Slave Communications Error	A communications error occurred for the EtherCAT slave or NX Unit that is allocated to an axis.	<ul style="list-style-type: none"> A communications error occurred for the EtherCAT slave or NX Unit that is allocated to an axis. 			S			W507
571D0000 hex (Ver. 1.02 to Ver. 1.09)	Too Many Reset Motion Control Error Instructions	There are more than 100 instances of the ResetMCErrror (Reset Motion Control Error) instruction.	<ul style="list-style-type: none"> There are more than 100 instances of the ResetMCErrror (Reset Motion Control Error) instruction declared in the user program. Instances inside function blocks are included. 				S		W507
644C0000 hex	Following Error Warning	The following error exceeded the Following Error Warning Value.	<ul style="list-style-type: none"> Performance of positioning operation is poor and the actual motion is slower than the command. 				S		W507
644D0000 hex	Velocity Warning	The command velocity exceeded the velocity warning value.	<ul style="list-style-type: none"> The command velocity exceeded the velocity warning value. 			U	S		W507
644E0000 hex	Acceleration Warning	The command acceleration exceeded the acceleration warning value.	<ul style="list-style-type: none"> The command acceleration rate exceeded the acceleration warning value. 			U	S		W507

Event code	Event name	Meaning	Assumed cause	Level					Reference
				Maj	Prt	Min	Obs	Info	
644F0000 hex	Deceleration Warning	The command deceleration exceeded the deceleration warning value.	<ul style="list-style-type: none"> The command deceleration rate exceeded the deceleration warning value. 			U	S		W507
64500000 hex	Positive Torque Warning	The torque command value exceeded the positive torque warning value.	<ul style="list-style-type: none"> The torque command value exceeded the positive torque warning value. 			U	S		W507
64510000 hex	Negative Torque Warning	The torque command value exceeded the negative torque warning value.	<ul style="list-style-type: none"> The torque command value exceeded the negative torque warning value. 			U	S		W507
64520000 hex	Command Position Overflow	The number of pulses for the command position overflowed.	<ul style="list-style-type: none"> In Linear Mode, the command position when converted to pulses exceeded the upper limit of signed 40-bit data. 			U	S		W507
64530000 hex	Command Position Underflow	The number of pulses for the command position exceeded the valid range. (It underflowed.)	<ul style="list-style-type: none"> In Linear Mode, the command position when converted to pulses exceeded the lower limit of signed 40-bit data. 			U	S		W507
64540000 hex	Actual Position Overflow	The number of pulses for the actual position overflowed.	<ul style="list-style-type: none"> The actual position when converted to pulses exceeded the upper limit of signed 40-bit data. 			U	S		W507
64550000 hex	Actual Position Underflow	The number of pulses for the actual position underflowed.	<ul style="list-style-type: none"> The actual position when converted to pulses exceeded the lower limit of signed 40-bit data. 			U	S		W507
74320000 hex	Slave Observation Detected	A warning was detected for an EtherCAT slave or NX Unit.	<ul style="list-style-type: none"> A warning was detected for the EtherCAT slave or NX Unit that is allocated to an axis. 			U	S		W507
743C0000 hex	Cannot Execute Save Cam Table Instruction	You cannot save a cam table to a file when non-volatile memory is being accessed by another operation.	<ul style="list-style-type: none"> An attempt was made to execute the MC_SaveCamTable instruction when another operation was accessing the non-volatile memory (e.g., transfer or data trace operation from the Sysmac Studio). 				S		W507

Event code	Event name	Meaning	Assumed cause	Level					Reference
				Maj	Prt	Min	Obs	Info	
94200000 hex	Notice of Insufficient Travel Distance to Achieve Blending Transit Velocity	There is not sufficient travel distance to accelerate or decelerate to the transit velocity during blending operation.	<ul style="list-style-type: none"> When the Acceleration/Deceleration Over parameter was set to <i>Use rapid acceleration/deceleration (Blending is changed to Buffered)</i>, the results of profile creation caused the acceleration/deceleration rate to be exceeded when blending was specified, so buffered was used. Blending was specified, but the target position was already reached, so it was changed to Buffered because the profile could not be created. <i>Blending</i> was specified for an interpolation instruction, but based on the results of profile creation, this was changed to <i>Buffered</i> because the execution time of the instruction before the transition was less than four control periods. 			U	S		W507
94210000 hex	Error Clear from MC Test Run Tab Page	An error was cleared from the MC Test Run Pane of the Sysmac Studio.	<ul style="list-style-type: none"> An error was cleared from the MC Test Run Pane of the Sysmac Studio. 					S	W507
94220000 hex	Slave Error Code Report	The error code was reported by the slave when a Slave Error Detected error occurred.	<ul style="list-style-type: none"> The error code was reported by the slave when a Slave Error Detected error (742F0000 hex) occurred. 					S	W507

Motion Control Instructions

The manual names are given below for the catalog numbers given in the *Reference* column of the event table.

Cat. No.	Manual name
W508	NJ/NX-series Motion Control Instructions Reference Manual

Event code	Event name	Meaning	Assumed cause	Level					Reference
				Maj	Prt	Min	Obs	Info	
34610000 hex	Process Data Object Setting Missing	The PDO mapping is not correct.	<ul style="list-style-type: none"> The PDOs that are required for the motion control instruction are not mapped. The relevant instruction was executed for a device that does not have an object that supports the instruction. A motion control instruction that specifies phase Z (<code>_mcEncoderMark</code>) as the trigger conditions was executed for an axis that is mapped to an OMRON GX-EC02 EtherCAT Encoder slave. 			S			W508

Event code	Event name	Meaning	Assumed cause	Level					Reference
				Maj	Prt	Min	Obs	Info	
54200000 hex	Electronic Gear Ratio Numerator Setting Out of Range	The parameter specified for the <i>RatioNumerator</i> input variable to a motion control instruction is out of range.	<ul style="list-style-type: none"> Instruction input parameter exceeded the valid range of the input variable. 			S			W508
54210000 hex	Electronic Gear Ratio Denominator Setting Out of Range	The parameter specified for the <i>RatioDenominator</i> input variable to a motion control instruction is out of range.	<ul style="list-style-type: none"> Instruction input parameter exceeded the valid range of the input variable. 			S			W508
54220000 hex	Target Velocity Setting Out of Range	The parameter specified for the <i>Velocity</i> input variable to a motion control instruction is out of range.	<ul style="list-style-type: none"> Instruction input parameter exceeded the valid range of the input variable. 			S			W508
54230000 hex	Acceleration Setting Out of Range	The parameter specified for the <i>Acceleration</i> input variable to a motion control instruction is out of range.	<ul style="list-style-type: none"> Instruction input parameter exceeded the valid range of the input variable. 			S			W508
54240000 hex	Deceleration Setting Out of Range	The parameter specified for the <i>Deceleration</i> input variable to a motion control instruction is out of range.	<ul style="list-style-type: none"> Instruction input parameter exceeded the valid range of the input variable. 			S			W508
54250000 hex	Jerk Setting Out of Range	The parameter specified for the <i>Jerk</i> input variable to a motion control instruction is out of range.	<ul style="list-style-type: none"> Instruction input parameter exceeded the valid range of the input variable. 			S			W508
54270000 hex	Torque Ramp Setting Out of Range	The parameter specified for the <i>TorqueRamp</i> input variable to a motion control instruction is out of range.	<ul style="list-style-type: none"> Instruction input parameter exceeded the valid range of the input variable. 			S			W508
54280000 hex	Master Coefficient Scaling Out of Range	The parameter specified for the <i>MasterScaling</i> input variable to a motion control instruction is out of range.	<ul style="list-style-type: none"> Instruction input parameter exceeded the valid range of the input variable. 			S			W508
54290000 hex	Slave Coefficient Scaling Out of Range	The parameter specified for the <i>SlaveScaling</i> input variable to a motion control instruction is out of range.	<ul style="list-style-type: none"> Instruction input parameter exceeded the valid range of the input variable. 			S			W508
542A0000 hex	Feeding Velocity Setting Out of Range	The parameter specified for the <i>FeedVelocity</i> input variable to a motion control instruction is out of range.	<ul style="list-style-type: none"> The Feed Velocity (input variable <i>FeedVelocity</i>) is still at the default (0). 			S			W508

Event code	Event name	Meaning	Assumed cause	Level					Reference
				Maj	Prt	Min	Obs	Info	
542B0000 hex	Buffer Mode Selection Out of Range	The parameter specified for the <i>BufferMode</i> input variable to a motion control instruction is out of range.	<ul style="list-style-type: none"> Instruction input parameter exceeded the valid range of the input variable. 			S			W508
542C0000 hex	Coordinate System Selection Out of Range	The parameter specified for the <i>CoordSystem</i> input variable to a motion control instruction is out of range.	<ul style="list-style-type: none"> Instruction input parameter exceeded the valid range of the input variable. 			S			W508
542D0000 hex	Circular Interpolation Mode Selection Out of Range	The parameter specified for the <i>CircMode</i> input variable to a motion control instruction is out of range.	<ul style="list-style-type: none"> Instruction input parameter exceeded the valid range of the input variable. 			S			W508
542E0000 hex	Direction Selection Out of Range	The parameter specified for the <i>Direction</i> input variable to a motion control instruction is out of range.	<ul style="list-style-type: none"> Instruction input parameter exceeded the valid range of the input variable. 			S			W508
542F0000 hex	Path Selection Out of Range	The parameter specified for the <i>PathChoice</i> input variable to a motion control instruction is out of range.	<ul style="list-style-type: none"> Instruction input parameter exceeded the valid range of the input variable. 			S			W508
54300000 hex	Position Type Selection Out of Range	The parameter specified for the <i>ReferenceType</i> input variable to a motion control instruction is out of range.	<ul style="list-style-type: none"> Instruction input parameter exceeded the valid range of the input variable. 			S			W508
54310000 hex	Travel Mode Selection Out of Range	The parameter specified for the <i>MoveMode</i> input variable to a motion control instruction is out of range.	<ul style="list-style-type: none"> Instruction input parameter exceeded the valid range of the input variable. 			S			W508
54320000 hex	Transition Mode Selection Out of Range	The parameter specified for the <i>TransitionMode</i> input variable to a motion control instruction is out of range.	<ul style="list-style-type: none"> Instruction input parameter exceeded the valid range of the input variable. <i>_mcAborting</i> or <i>_mcBuffered</i> was specified for <i>BufferMode</i> and <i>_mcTMCornerSuperimposed</i> was specified for <i>TransitionMode</i>. 			S			W508
54330000 hex	Continue Method Selection Out of Range	The value of the reserved input variable <i>Continuous</i> to a motion control instruction changed.	<ul style="list-style-type: none"> The value of the reserved input variable <i>Continuous</i> changed. 			S			W508
54340000 hex	Combine Mode Selection Out of Range	The parameter specified for the <i>CombineMode</i> input variable to a motion control instruction is out of range.	<ul style="list-style-type: none"> Instruction input parameter exceeded the valid range of the input variable. 			S			W508

Event code	Event name	Meaning	Assumed cause	Level					Reference
				Maj	Prt	Min	Obs	Info	
54350000 hex	Synchronization Start Condition Selection Out of Range	The parameter specified for the <i>LinkOption</i> input variable to a motion control instruction is out of range.	<ul style="list-style-type: none"> Instruction input parameter exceeded the valid range of the input variable. 			S			W508
54360000 hex	Master and Slave Defined as Same Axis	The same axis is specified for the <i>Master</i> and <i>Slave</i> input variables to a motion control instruction.	<ul style="list-style-type: none"> The parameter is the same for the <i>Master</i> and <i>Slave</i> input variables to the instruction. 			S			W508
54370000 hex	Master and Auxiliary Defined as Same Axis	The same axis is specified for the <i>Master</i> and <i>Auxiliary</i> input variables to a motion control instruction.	<ul style="list-style-type: none"> The parameter is the same for the <i>Master</i> and <i>Auxiliary</i> input variables to the instruction. 			S			W508
54380000 hex	Master/Slave Axis Numbers Not in Ascending Order	The axis numbers specified for the <i>Master</i> and <i>Slave</i> input variables to a motion control instruction are not in ascending order.	<ul style="list-style-type: none"> The parameters for the <i>Master</i> and <i>Slave</i> input variables to the instruction were not in ascending order when <i>_mclatestCommand</i> was specified for the <i>ReferenceType</i> input variable to the instruction. 			S			W508
54390000 hex	Incorrect Cam Table Specification	The parameter specified for the <i>CamTable</i> input variable to a motion control instruction is out of range.	<ul style="list-style-type: none"> Something other than a cam data variable was specified for the <i>CamTable</i> input variable to the instruction. 			S			W508
543A0000 hex	Synchronization Stopped	A synchronized control motion control instruction was executed, but conditions required for execution were not met.	<ul style="list-style-type: none"> The MC_CamOut (End Cam Operation) instruction was executed even though the MC_CamIn (Start Cam Operation) instruction is not being executed. The MC_GearOut (End Gear Operation) instruction was executed even though the MC_GearIn (Start Gear Operation) or the MC_GearInPos (Positioning Gear Operation) instruction is not being executed. The MC_Phasing (Shift Master Axis Phase) instruction was executed even though the MC_CamIn (Start Cam Operation), MC_GearIn (Start Gear Operation), MC_GearInPos (Start Gear Operation), or MC_MoveLink (Synchronous Positioning) instruction is not being executed. 			S			W508
543B0000 hex	Motion Control Instruction Re-execution Disabled	An attempt was made to re-execute a motion control instruction that cannot be re-executed.	<ul style="list-style-type: none"> A motion control instruction that cannot be re-executed was re-executed. 			S			W508

Event code	Event name	Meaning	Assumed cause	Level					Reference
				Maj	Prt	Min	Obs	Info	
543C 0000 hex	Motion Control Instruction Multi-execution Disabled	Multiple functions that cannot be executed simultaneously were executed for the same target (MC common, axis, or axes group).	<ul style="list-style-type: none"> Multiple functions that cannot be executed simultaneously were executed for the same target (MC common or axis). 			S			W508
543D 0000 hex	Instruction Not Allowed for Encoder Axis Type	An operation instruction was executed for an encoder axis.	<ul style="list-style-type: none"> An operation instruction was executed for an encoder axis. 			S			W508
543E 0000 hex	Instruction Cannot Be Executed during Multi-axes Coordinated Control	<ul style="list-style-type: none"> An operation instruction was executed for an axis or an axes group that was in a coordinated multi-axes motion. A robot instruction that you cannot use for an axes group in a <i>GroupEnable</i> state was executed. 	<ul style="list-style-type: none"> An operation instruction was executed for an axis or an axes group that was in a coordinated multi-axes motion. The MC_SetKinTransform instruction was executed for an axes group in a <i>GroupEnable</i> state. 			S			W508
543F 0000 hex	Multi-axes Coordinated Control Instruction Executed for Disabled Axes Group	A multi-axes coordinated control instruction was executed for an axes group that was in a <i>GroupDisable</i> state.	<ul style="list-style-type: none"> A multi-axes coordinated control instruction was executed for an axes group that was in a <i>GroupDisable</i> state. One of the following instructions was executed for an axes group that was in a <i>GroupDisable</i> state. MC_MoveTimeAbsolute MC_SyncLinearConveyor MC_SyncOut MC_RobotJog 			S			W508
5440 0000 hex	Axes Group Cannot Be Enabled	Execution of the MC_GroupEnable (Enable Axes Group) instruction failed.	<ul style="list-style-type: none"> When the MC_GroupEnable (Enable Axes Group) instruction was executed, there was a composition axis that was not stopped. When the MC_GroupEnable (Enable Axes Group) instruction was executed, there was a composition axis for which the MC_TouchProbe (Enable External Latch) instruction was being executed. 			S			W508
5441 0000 hex	Impossible Axis Operation Specified when the Servo is OFF	An operation instruction was executed for an axis for which the Servo is OFF.	<ul style="list-style-type: none"> An operation instruction was executed for an axis for which the Servo is OFF. Home was preset with the MC_Home or MC_HomeWith-Parameter instruction for an axis for which EtherCAT process data communications are not established. 			S			W508

Event code	Event name	Meaning	Assumed cause	Level					Reference
				Maj	Prt	Min	Obs	Info	
54420000 hex	Composition Axis Stopped Error	A motion instruction was executed for an axes group while the MC_Stop instruction was being executed for a composition axis.	<ul style="list-style-type: none"> A motion instruction was executed for an axes group while the MC_Stop instruction was being executed for a composition axis. 			S			W508
54430000 hex	Motion Control Instruction Multi-execution Buffer Limit Exceeded	The number of motion control instructions that is buffered for Buffered or Blending Buffer Modes exceeded the buffer limit.	<ul style="list-style-type: none"> An axis instruction was executed when there was already a current instruction and a buffered instruction for the same axis. An axes group instruction was executed when there was already eight current instructions and buffered instructions for the same axis. 			S			W508
54440000 hex	Insufficient Travel Distance	The specified motion cannot be executed for the deceleration rate or acceleration rate that was specified for multi-execution or re-execution of a positioning instruction.	<ul style="list-style-type: none"> Stopping at the target position was not possible for the specified acceleration/deceleration rate for multi-execution or re-execution of a positioning instruction when the Acceleration/Deceleration Over parameter was set to generate a minor fault and stop. 			S			W508
54450000 hex	Insufficient Travel Distance to Achieve Blending Transit Velocity	There is not sufficient travel distance to accelerate or decelerate to the transit velocity.	<ul style="list-style-type: none"> There was not sufficient travel distance to accelerate the current command to the transit velocity when the Acceleration/Deceleration Over parameter was set to generate a minor fault and stop. 			S			W508
54460000 hex	Move Link Constant Velocity Insufficient Travel Distance	The constant-velocity travel distance of the master axis is less than zero.	<ul style="list-style-type: none"> The constant velocity travel distance of the master axis is below 0 for the MC_MoveLink (Synchronous Positioning) instruction. 			S			W508
54470000 hex	Positioning Gear Operation Insufficient Target Velocity	For the MC_GearInPos (Positioning Gear Operation) instruction, the target velocity of the slave axis is too small to achieve the required velocity.	<ul style="list-style-type: none"> For the MC_GearInPos (Positioning Gear Operation) instruction, the value of the <i>Velocity</i> (Target Velocity) input variable is smaller than the master axis velocity multiplied by the gear ratio when the instruction was executed. 			S			W508
54480000 hex	Same Start Point and End Point for Circular Interpolation	The start point and end point were the same when the radius method was specified for the MC_MoveCircular2D (Circular 2D Interpolation) instruction. Or, the start point, end point, and border point were the same when the border point method was specified.	<ul style="list-style-type: none"> The start point and end point were the same when the radius method was specified for the MC_MoveCircular2D (Circular 2D Interpolation) instruction. The start point, end point, and border point were the same when the border point method was specified for the MC_MoveCircular2D (Circular 2D Interpolation) instruction. 			S			W508

Event code	Event name	Meaning	Assumed cause	Level					Reference
				Maj	Prt	Min	Obs	Info	
54490000 hex	Circular Interpolation Center Specification Position Out of Range	The position specified for the center point exceeded the allowed range when the center method was specified for the MC_MoveCircular2D (Circular 2D Interpolation) instruction.	<ul style="list-style-type: none"> The difference between the distance from the start point to the center point and the distance between the end point to the center point exceeded the permitted value specified for the correction allowance ratio in the axes group settings when the center designation method was specified for the MC_MoveCircular2D (Circular 2D Interpolation) instruction. 			S			W508
544A0000 hex	Instruction Execution Error Caused by Count Mode Setting	An instruction that cannot be used when the Count Mode is set to Rotary Mode was executed for an axis that was set to Rotary Mode.	<ul style="list-style-type: none"> An instruction that cannot be used when the Count Mode is set to Rotary Mode was executed for an axis that was set to Rotary Mode. 			S			W508
544C0000 hex	Parameter Selection Out of Range	The parameter specified for the <i>ParameterNumber</i> input variable to a motion control instruction is out of range.	<ul style="list-style-type: none"> Instruction input parameter exceeded the valid range of the input variable. 			S			W508
544D0000 hex	Stop Method Selection Out of Range	The parameter specified for the <i>StopMode</i> input variable to a motion control instruction is out of range.	<ul style="list-style-type: none"> Instruction input parameter exceeded the valid range of the input variable. 			S			W508
544E0000 hex	Latch ID Selection Out of Range for Trigger Input Condition	The parameter specified for the <i>TriggerInput::LatchID</i> input variable to a motion control instruction is out of range.	<ul style="list-style-type: none"> Instruction input parameter exceeded the valid range of the input variable. 			S			W508
544F0000 hex	Setting Out of Range for Writing MC Setting	The parameter specified for the <i>SettingValue</i> input variable to a motion control instruction is out of range.	<ul style="list-style-type: none"> Instruction input parameter exceeded the valid range of the input variable. The parameter specification and the data type of the setting value do not agree. 			S			W508
54500000 hex	Trigger Input Condition Mode Selection Out of Range	The parameter specified for the <i>TriggerInput::Mode</i> input variable to a motion control instruction is out of range.	<ul style="list-style-type: none"> Instruction input parameter exceeded the valid range of the input variable. 			S			W508
54510000 hex	Drive Trigger Signal Selection Out of Range for Trigger Input Condition	The parameter specified for the <i>TriggerInput::InputDrive</i> input variable to a motion control instruction is out of range.	<ul style="list-style-type: none"> Instruction input parameter exceeded the valid range of the input variable. 			S			W508

Event code	Event name	Meaning	Assumed cause	Level					Reference
				Maj	Prt	Min	Obs	Info	
54530000 hex	Motion Control Instruction Re-execution Disabled (Axis Specification)	An attempt was made to change the parameter for the <i>Axis</i> input variable when re-executing a motion control instruction. (This input variable cannot be changed when re-executing an instruction.)	<ul style="list-style-type: none"> A parameter for an input variable that cannot be changed for re-execution was changed. 			S			W508
54540000 hex	Motion Control Instruction Re-execution Disabled (Buffer Mode Selection)	An attempt was made to change the parameter for the <i>BufferMode</i> input variable when re-executing a motion control instruction. (This input variable cannot be changed when re-executing an instruction.)	<ul style="list-style-type: none"> A parameter for an input variable that cannot be changed for re-execution was changed. 			S			W508
54550000 hex	Motion Control Instruction Re-execution Disabled (Direction Selection)	An attempt was made to change the parameter for the <i>Direction</i> input variable when re-executing a motion control instruction. (This input variable cannot be changed when re-executing an instruction.)	<ul style="list-style-type: none"> An input variable that cannot be changed for re-execution was changed. 			S			W508
54560000 hex	Motion Control Instruction Re-execution Disabled (Execution Mode)	An attempt was made to change the parameter for the <i>Periodic</i> input variable when re-executing a motion control instruction. (This input variable cannot be changed when re-executing an instruction.)	<ul style="list-style-type: none"> A parameter for an input variable that cannot be changed for re-execution was changed. 			S			W508
54570000 hex	Motion Control Instruction Re-execution Disabled (Axes Group Specification)	An attempt was made to change the parameter for the <i>AxesGroup</i> input variable when re-executing a motion control instruction. (This input variable cannot be changed when re-executing an instruction.)	<ul style="list-style-type: none"> A parameter for an input variable that cannot be changed for re-execution was changed. 			S			W508
54580000 hex	Motion Control Instruction Re-execution Disabled (Jerk Setting)	An attempt was made to change the parameter for the <i>Jerk</i> input variable when re-executing a motion control instruction. (This input variable cannot be changed when re-executing an instruction.)	<ul style="list-style-type: none"> A parameter for an input variable that cannot be changed for re-execution was changed. 			S			W508

Event code	Event name	Meaning	Assumed cause	Level					Reference
				Maj	Prt	Min	Obs	Info	
54590000 hex	Motion Control Instruction Re-execution Disabled (Master Axis)	An attempt was made to change the parameter for the <i>Master</i> input variable when re-executing a motion control instruction. (This input variable cannot be changed when re-executing an instruction.)	<ul style="list-style-type: none"> A parameter for an input variable that cannot be changed for re-execution was changed. 			S			W508
545A0000 hex	Motion Control Instruction Re-execution Disabled (MasterOffset)	An attempt was made to change the parameter for the <i>MasterOffset</i> input variable when re-executing a motion control instruction. (This input variable cannot be changed when re-executing an instruction.)	<ul style="list-style-type: none"> A parameter for an input variable that cannot be changed for re-execution was changed. 			S			W508
545B0000 hex	Motion Control Instruction Re-execution Disabled (MasterScaling)	An attempt was made to change the parameter for the <i>MasterScaling</i> input variable when re-executing a motion control instruction. (This input variable cannot be changed when re-executing an instruction.)	<ul style="list-style-type: none"> A parameter for an input variable that cannot be changed for re-execution was changed. 			S			W508
545C0000 hex	Motion Control Instruction Re-execution Disabled (MasterStartDistance)	An attempt was made to change the parameter for the <i>MasterStartDistance</i> input variable when re-executing a motion control instruction. (This input variable cannot be changed when re-executing an instruction.)	<ul style="list-style-type: none"> A parameter for an input variable that cannot be changed for re-execution was changed. 			S			W508
545D0000 hex	Motion Control Instruction Re-execution Disabled (Continuous)	An attempt was made to change the parameter for the <i>Continuous</i> input variable when re-executing a motion control instruction. (This input variable cannot be changed when re-executing an instruction.)	<ul style="list-style-type: none"> A parameter for an input variable that cannot be changed for re-execution was changed. 			S			W508

Event code	Event name	Meaning	Assumed cause	Level					Reference
				Maj	Prt	Min	Obs	Info	
545E0000 hex	Motion Control Instruction Re-execution Disabled (MoveMode)	An attempt was made to change the parameter for the <i>MoveMode</i> input variable when re-executing a motion control instruction. (This input variable cannot be changed when re-executing an instruction.)	<ul style="list-style-type: none"> A parameter for an input variable that cannot be changed for re-execution was changed. 			S			W508
545F0000 hex	Illegal Auxiliary Axis Specification	The axis specified for the <i>Auxiliary</i> input variable to a motion control instruction does not exist.	<ul style="list-style-type: none"> An axis does not exist for the variable specified for the <i>Auxiliary</i> input variable to the instruction. 			S			W508
54600000 hex	Illegal Axis Specification	The axis specified for the <i>Axis</i> input variable to a motion control instruction does not exist.	<ul style="list-style-type: none"> An axis does not exist for the variable specified for the <i>Axis</i> input variable to the instruction. 			S			W508
54610000 hex	Illegal Axes Group Specification	The axes group specified for the <i>AxesGroup</i> input variable to a motion control instruction does not exist or is not a used group.	<ul style="list-style-type: none"> An axes group does not exist for the variable specified for the <i>AxesGroup</i> input variable to the instruction. The axes group specified for the <i>AxesGroup</i> input variable to the instruction is not specified as a used group. 			S			W508
54620000 hex	Illegal Master Axis Specification	The axis that is specified for the <i>Master</i> input variable to a motion control instruction is not correct.	<ul style="list-style-type: none"> An axis does not exist for the variable specified for the <i>Master</i> input variable to the instruction. The axis that was specified for the <i>Master</i> input variable to the MC_Phasing (Shift Master Axis Phase) instruction is not the master axis for syncing. The master axis and a slave axis are not assigned to the same task. 			S			W508
54630000 hex	Motion Control Instruction Re-execution Disabled (SlaveOffset)	An attempt was made to change the <i>SlaveOffset</i> input variable when re-executing a motion control instruction. (This input variable cannot be changed when re-executing an instruction.)	<ul style="list-style-type: none"> A parameter for an input variable that cannot be changed for re-execution was changed. 			S			W508
54640000 hex	Motion Control Instruction Re-execution Disabled (SlaveScaling)	An attempt was made to change the <i>SlaveScaling</i> input variable when re-executing a motion control instruction. (This input variable cannot be changed when re-executing an instruction.)	<ul style="list-style-type: none"> A parameter for an input variable that cannot be changed for re-execution was changed. 			S			W508

Event code	Event name	Meaning	Assumed cause	Level					Reference
				Maj	Prt	Min	Obs	Info	
54650000 hex	Motion Control Instruction Re-execution Disabled (StartPosition)	An attempt was made to change the <i>StartPosition</i> input variable when re-executing a motion control instruction. (This input variable cannot be changed when re-executing an instruction.)	<ul style="list-style-type: none"> A parameter for an input variable that cannot be changed for re-execution was changed. 			S			W508
54660000 hex	Instruction Execution Error with Undefined Home	High-speed homing or an interpolation instruction was executed when home was undefined.	<ul style="list-style-type: none"> High-speed homing was executed when home was undefined. An interpolation instruction was executed for an axes group that includes an axis with no defined home. One of the following robot instructions was executed for an axes group that includes a logical axis with no defined home. MC_SetKinTransform MC_MoveTimeAbsolute MC_SyncLinearConveyor MC_SyncOut MC_GroupMon MC_RobotJog 			S			W508
54670000 hex	Motion Control Instruction Re-execution Disabled (Position Type)	An attempt was made to change the <i>ReferenceType</i> input variable when re-executing a motion control instruction. (This input variable cannot be changed when re-executing an instruction.)	<ul style="list-style-type: none"> A parameter for an input variable that cannot be changed for re-execution was changed. 			S			W508
54680000 hex	Unused Axis Specification for Master Axis	The master axis specified for a motion control instruction is an unused axis.	<ul style="list-style-type: none"> The master axis specified for a motion control instruction is an unused axis. 			S			W508
54690000 hex	First Position Setting Out of Range	The parameter specified for the <i>FirstPosition</i> input variable to a motion control instruction is out of range.	<ul style="list-style-type: none"> Instruction input parameter exceeded the valid range of the input variable. 			S			W508
546A0000 hex	Last Position Setting Out of Range	The parameter specified for the <i>LastPosition</i> input variable to a motion control instruction is out of range.	<ul style="list-style-type: none"> Instruction input parameter exceeded the valid range of the input variable. 			S			W508
546B0000 hex	Illegal First/Last Position Size Relationship (Linear Mode)	The parameter specified for the <i>LastPosition</i> input variable to a motion control instruction is smaller than the parameter specified for the <i>FirstPosition</i> input variable.	<ul style="list-style-type: none"> The value of the <i>LastPosition</i> input parameter is less than the value of the <i>FirstPosition</i> input variable for the instruction when the Count Mode is set to Linear Mode. 			S			W508

Event code	Event name	Meaning	Assumed cause	Level					Reference
				Maj	Prt	Min	Obs	Info	
546C0000 hex	Master Sync Start Position Setting Out of Range	The parameter specified for the <i>MasterSyncPosition</i> input variable to a motion control instruction is out of range.	<ul style="list-style-type: none"> Instruction input parameter exceeded the valid range of the input variable. 			S			W508
546D0000 hex	Slave Sync Start Position Setting Out of Range	The parameter specified for the <i>SlaveSyncPosition</i> input variable to a motion control instruction is out of range.	<ul style="list-style-type: none"> Instruction input parameter exceeded the valid range of the input variable. 			S			W508
546E0000 hex	Duplicate Latch ID for Trigger Input Condition	The same latch ID was specified for more than one motion control instruction.	<ul style="list-style-type: none"> The same latch ID is used simultaneously for more than one of the following instructions: MC_TouchProbe (Enable External Latch) instruction, MC_MoveLink (Synchronous Positioning) instruction, and MC_MoveFeed (Interrupt Feeding) instruction. The MC_AbortTrigger (Disable External Latch) instruction was executed to cancel a latch that was used by an instruction other than the MC_TouchProbe (Enable External Latch) instruction. 			S			W508
546F0000 hex	Jerk Override Factor Out of Range	The parameter specified for the <i>JerkFactor</i> input variable to a motion control instruction is out of range.	<ul style="list-style-type: none"> Instruction input parameter exceeded the valid range of the input variable. 			S			W508
54700000 hex	Acceleration/Deceleration Override Factor Out of Range	The parameter specified for the <i>AccFactor</i> input variable to a motion control instruction is out of range.	<ul style="list-style-type: none"> Instruction input parameter exceeded the valid range of the input variable. 			S			W508
54710000 hex	First Position Method Specification Out of Range	The parameter specified for the <i>StartMode</i> input variable to a motion control instruction is out of range.	<ul style="list-style-type: none"> Instruction input parameter exceeded the valid range of the input variable. 			S			W508
54720000 hex	Motion Control Instruction Re-execution Disabled (First Position Method)	An attempt was made to change the <i>StartMode</i> input variable when re-executing a motion control instruction. (This input variable cannot be changed when re-executing an instruction.)	<ul style="list-style-type: none"> A parameter for an input variable that cannot be changed for re-execution was changed. 			S			W508
54740000 hex	Unused Axis Specification for Auxiliary Axis	The axis specified for the <i>Auxiliary</i> input variable to a motion control instruction is an unused axis.	<ul style="list-style-type: none"> The axis specified for the <i>Auxiliary</i> input variable to the instruction is an unused axis. 			S			W508

Event code	Event name	Meaning	Assumed cause	Level					Reference
				Maj	Prt	Min	Obs	Info	
54750000 hex	Position Gear Value Error	Synchronized motion is not possible for the velocity, acceleration rate, and deceleration rate that were input to a motion control instruction.	<ul style="list-style-type: none"> The specified synchronized motion cannot be performed at the velocity, acceleration rate, or deceleration rate that is input to the instruction. 			S			W508
54760000 hex	Position Gear Master Axis Zero Velocity	The velocity of the master axis was zero when a motion control instruction was started.	<ul style="list-style-type: none"> The velocity of the master axis was 0 when the instruction was started. 			S			W508
54780000 hex	Target Position Setting Out of Range	The parameter specified for the <i>Position</i> input variable to a motion control instruction is out of range.	<ul style="list-style-type: none"> Instruction input parameter exceeded the valid range of the input variable. The target position of a Rotary Mode axis is not within the ring setting range. 			S			W508
54790000 hex	Travel Distance Out of Range	The parameter that was specified for the <i>Distance</i> input variable to a motion control instruction is out of range or the target position with the value of <i>Distance</i> added is out of range.	<ul style="list-style-type: none"> The absolute value of the instruction input parameter exceeded the range of 40-bit data when it is converted to pulses. For a Linear Mode axis, the target position with the travel distance added exceeded signed 40-bit data when the absolute value is converted to pulses. 			S			W508
547A0000 hex	Cam Table Start Point Setting Out of Range	The parameter specified for the <i>StartPosition</i> input variable to a motion control instruction is out of range.	<ul style="list-style-type: none"> Instruction input parameter exceeded the valid range of the input variable. 			S			W508
547B0000 hex	Cam Master Axis Following First Position Setting Out of Range	The parameter specified for the <i>MasterStartDistance</i> input variable to a motion control instruction is out of range.	<ul style="list-style-type: none"> Instruction input parameter exceeded the valid range of the input variable. 			S			W508
547C0000 hex	Circular Interpolation Radius Setting Error	It was not possible to create a circular path for the specified radius when the radius method was specified for the MC_MoveCircular2D (Circular 2D Interpolation) instruction.	<ul style="list-style-type: none"> For the MC_MoveCircular2D (Circular 2D Interpolation) instruction, it was not possible to create a circular path for the specified radius when the radius method was specified for circular interpolation. 			S			W508
547D0000 hex	Circular Interpolation Radius Overflow	For the MC_MoveCircular2D (Circular 2D Interpolation) instruction, the radius of the circle exceeded the maximum value for the border point or center specification method.	<ul style="list-style-type: none"> For the MC_MoveCircular2D (Circular 2D Interpolation) instruction, the radius of the circle exceeded 40-bit data when converted to pulses for the border point or center specification method. 			S			W508

Event code	Event name	Meaning	Assumed cause	Level					Reference
				Maj	Prt	Min	Obs	Info	
547E0000 hex	Circular Interpolation Setting Out of Range	The parameter specified for the <i>CircAxes</i> input variable to a motion control instruction is out of range.	<ul style="list-style-type: none"> Instruction input parameter exceeded the valid range of the input variable. The axes that were specified in <i>CircAxes</i> are not included in the composition axes in the Axes Group Settings. The same axis was specified for both axes of <i>CircAxes</i>. 			S			W508
547F0000 hex	Auxiliary/Slave Axis Numbers Not in Ascending Order	The values of the parameters for the <i>Auxiliary</i> and <i>Slave</i> input variables to a motion control instruction are not in ascending order.	<ul style="list-style-type: none"> The parameters for the <i>Auxiliary</i> and <i>Slave</i> input variables to the instruction are not in ascending order. 			S			W508
54800000 hex	Cam Table Property Ascending Data Error at Update	A phase that was not in ascending order was found during calculating the number of valid data. Or, after calculations, the number of valid data is 0.	<ul style="list-style-type: none"> A phase that was not in ascending order was found when calculating the number of valid data. After calculations, the number of valid data is 0. 			S			W508
54810000 hex	MC_Write Target Out of Range	The parameter specified for the <i>Target</i> input variable to a motion control instruction is out of range.	<ul style="list-style-type: none"> Instruction input parameter exceeded the valid range of the input variable. 			S			W508
54820000 hex	Master Travel Distance Specification Out of Range	The parameter specified for the <i>MasterDistance</i> input variable to a motion control instruction is out of range.	<ul style="list-style-type: none"> Instruction input parameter exceeded the valid range of the input variable. 			S			W508
54830000 hex	Master Distance in Acceleration Specification Out of Range	The parameter specified for the <i>MasterDistance-ACC</i> input variable to a motion control instruction is out of range.	<ul style="list-style-type: none"> Instruction input parameter exceeded the valid range of the input variable. 			S			W508
54840000 hex	Master Distance in Deceleration Specification Out of Range	The parameter specified for the <i>MasterDistance-DEC</i> input variable to a motion control instruction is out of range.	<ul style="list-style-type: none"> Instruction input parameter exceeded the valid range of the input variable. 			S			W508
54870000 hex	Execution Mode Selection Out of Range	The parameter specified for the <i>ExecutionMode</i> input variable to a motion control instruction is out of range.	<ul style="list-style-type: none"> Instruction input parameter exceeded the valid range of the input variable. 			S			W508

Event code	Event name	Meaning	Assumed cause	Level					Reference
				Maj	Prt	Min	Obs	Info	
54880000 hex	Permitted Following Error Out of Range	The parameter specified for the <i>PermittedDeviation</i> input variable to a motion control instruction is out of range.	<ul style="list-style-type: none"> Instruction input parameter exceeded the valid range of the input variable. 			S			W508
54890000 hex	Border Point/Center Position/Radius Specification Out of Range	The parameter specified for the <i>AuxPoint</i> input variable to a motion control instruction is out of range.	<ul style="list-style-type: none"> The value of <i>AuxPoint</i> exceeded signed 40-bit data when converted to pulses for the border point or center specification method. For a radius specifications, the absolute value of <i>AuxPoint[0]</i> exceeded 40-bit data when converted to pulses. 			S			W508
548A0000 hex	End Point Specification Out of Range	The parameter specified for the <i>EndPoint</i> input variable to a motion control instruction is out of range.	<ul style="list-style-type: none"> The instruction input parameter exceeded the range of signed 40-bit data when it is converted to pulses. 			S			W508
548B0000 hex	Slave Travel Distance Specification Out of Range	The parameter specified for the <i>SlaveDistance</i> input variable to a motion control instruction is out of range.	<ul style="list-style-type: none"> The instruction input parameter exceeded the range of 40-bit data when it is converted to pulses. 			S			W508
548C0000 hex	Phase Shift Amount Out of Range	The parameter specified for the <i>PhaseShift</i> input variable to a motion control instruction is out of range.	<ul style="list-style-type: none"> The absolute value of the instruction input parameter exceeded the range of 40-bit data when it is converted to pulses. 			S			W508
548D0000 hex	Feeding Distance Out of Range	The parameter specified for the <i>FeedDistance</i> input variable to a motion control instruction is out of range.	<ul style="list-style-type: none"> The absolute value of the instruction input parameter exceeded the range of 40-bit data when it is converted to pulses. 			S			W508
548E0000 hex	Auxiliary and Slave Defined as Same Axis	The same axis was specified for the <i>Auxiliary</i> and <i>Slave</i> input variables to a motion control instruction.	<ul style="list-style-type: none"> The parameter is the same for the <i>Auxiliary</i> and <i>Slave</i> input variables to the instruction. 			S			W508
548F0000 hex	Relative Position Selection Out of Range	The parameter specified for the <i>Relative</i> input variable to a motion control instruction is out of range.	<ul style="list-style-type: none"> Instruction input parameter exceeded the valid range of the input variable. 			S			W508
54900000 hex	Cam Transition Specification Out of Range	The parameter specified for the <i>CamTransition</i> input variable to a motion control instruction is out of range.	<ul style="list-style-type: none"> Instruction input parameter exceeded the valid range of the input variable. 			S			W508

Event code	Event name	Meaning	Assumed cause	Level					Reference
				Maj	Prt	Min	Obs	Info	
54910000 hex	Synchronized Control End Mode Selection Out of Range	The parameter specified for the <i>OutMode</i> input variable to a motion control instruction is out of range.	<ul style="list-style-type: none"> Instruction input parameter exceeded the valid range of the input variable. 			S			W508
54920000 hex	Enable External Latch Instruction Execution Disabled	<i>_mclImmediateStop</i> was specified for the <i>StopMode</i> input variable when the MC_TouchProbe (Enable External Latch) instruction was executed in Drive Mode for an encoder axis.	<ul style="list-style-type: none"> <i>_mclImmediateStop</i> was specified for the <i>StopMode</i> input variable when the MC_TouchProbe (Enable External Latch) instruction was executed in Drive Mode for an encoder axis. 			S			W508
54930000 hex	Master Axis Offset Out of Range	The parameter specified for the <i>MasterOffset</i> input variable to a motion control instruction is out of range.	<ul style="list-style-type: none"> The instruction input parameter exceeded the range of signed 40-bit data when it is converted to pulses. 			S			W508
54940000 hex	Slave Axis Offset Out of Range	The parameter specified for the <i>SlaveOffset</i> input variable to a motion control instruction is out of range.	<ul style="list-style-type: none"> The instruction input parameter exceeded the range of signed 40-bit data when it is converted to pulses. 			S			W508
54950000 hex	Command Current Position Count Selection Out of Range	The parameter specified for the <i>CmdPosMode</i> input variable to a motion control instruction is out of range.	<ul style="list-style-type: none"> Instruction input parameter exceeded the valid range of the input variable. 			S			W508
54960000 hex	Master Axis Gear Ratio Numerator Out of Range	The parameter specified for the <i>RatioNumerator-Master</i> input variable to a motion control instruction is out of range.	<ul style="list-style-type: none"> Instruction input parameter exceeded the valid range of the input variable. 			S			W508
54970000 hex	Master Axis Gear Ratio Denominator Out of Range	The parameter specified for the <i>RatioDenominator-Master</i> input variable to a motion control instruction is out of range.	<ul style="list-style-type: none"> Instruction input parameter exceeded the valid range of the input variable. 			S			W508
54980000 hex	Auxiliary Axis Gear Ratio Numerator Out of Range	The parameter specified for the <i>RatioNumeratorAuxiliary</i> input variable to a motion control instruction is out of range.	<ul style="list-style-type: none"> Instruction input parameter exceeded the valid range of the input variable. 			S			W508
54990000 hex	Auxiliary Axis Gear Ratio Denominator Out of Range	The parameter specified for the <i>RatioDenominatorAuxiliary</i> input variable to a motion control instruction is out of range.	<ul style="list-style-type: none"> Instruction input parameter exceeded the valid range of the input variable. 			S			W508

Event code	Event name	Meaning	Assumed cause	Level					Reference
				Maj	Prt	Min	Obs	Info	
549A0000 hex	Master Axis Position Type Selection Out of Range	The parameter specified for the <i>ReferenceTypeMaster</i> input variable to a motion control instruction is out of range.	<ul style="list-style-type: none"> Instruction input parameter exceeded the valid range of the input variable. 			S			W508
549B0000 hex	Auxiliary Axis Position Type Selection Out of Range	The parameter specified for the <i>ReferenceTypeAuxiliary</i> input variable to a motion control instruction is out of range.	<ul style="list-style-type: none"> Instruction input parameter exceeded the valid range of the input variable. 			S			W508
549C0000 hex	Target Position Ring Counter Out of Range	Operation is not possible because the target position is out of range for the ring counter of the executed instruction.	<ul style="list-style-type: none"> High-speed homing was executed when 0 was not included in the ring counter. 			S			W508
549D0000 hex (Ver. 1.01 or later)	Axes Group Composition Axis Setting Out of Range	The parameter specified for the <i>Axes</i> input variable to a motion control instruction is out of range.	<ul style="list-style-type: none"> Instruction input parameter exceeded the valid range of the input variable. The composition axes in the axes group are not assigned to the same task. 			S			W508
549E0000 hex (Ver. 1.04 or later)	Axis Use Setting Out of Range	The parameter specified for the <i>AxisUse</i> input variable to a motion control instruction is out of range.	<ul style="list-style-type: none"> Instruction input parameter exceeded the valid range of the input variable. 			S			W508
57000000 hex (Ver. 1.03 or later)	Homing Parameter Setting Out of Range	The parameter specified for the <i>HomingParameter</i> input variable to a motion control instruction is out of range.	<ul style="list-style-type: none"> Instruction input parameter exceeded the valid range of the input variable. 			S			W508
57020000 hex (Ver. 1.04 or later)	Axis Use Change Error	The <i>MC_ChangeAxisUse</i> (Change Axis Use) instruction was executed when the axis was not stopped or when the command velocity of the axis was saturated.	<ul style="list-style-type: none"> The <i>MC_ChangeAxisUse</i> (Change Axis Use) instruction was executed when the axis was not stopped or when the command velocity of the axis was saturated. 			S			W508
57030000 hex (Ver. 1.06 or later)	Cannot Change Axis Use	The <i>MC_ChangeAxisUse</i> (Change Axis Use) instruction was executed in a way that would cause the maximum number of used real axes or the maximum number of used motion control servo axes to be exceeded.	<ul style="list-style-type: none"> The <i>MC_ChangeAxisUse</i> (Change Axis Use) instruction was executed in a way that would cause the maximum number of used real axes to be exceeded. The <i>MC_ChangeAxisUse</i> (Change Axis Use) instruction was executed in a way that would cause the maximum number of used motion control servo axes to be exceeded. 			S			W508

Event code	Event name	Meaning	Assumed cause	Level					Reference
				Maj	Prt	Min	Obs	Info	
57200000 hex (Ver. 1.04 or later)	Motion Control Parameter Setting Error When Changing Axis Use	The motion control parameter settings for the axis that was changed to a used axis are incorrect.	<ul style="list-style-type: none"> The MC_ChangeAxisUse (Change Axis Use) instruction was used to change an unused axis to a used axis, but the motion control parameter settings of the axis are not correct. The power supply was interrupted while a download of the motion control parameter settings was in progress. The non-volatile memory is faulty or the life of the non-volatile memory has been exceeded. 			S			W508
57210000 hex (Ver. 1.04 or later)	Required Process Data Object Not Set When Changing Axis Use	The objects that are required for the axis type of the axis that was changed to a used axis are not set.	<ul style="list-style-type: none"> The objects that are required for the axis type of the axis that was changed to a used axis are not set in the PDO map settings. The power supply was interrupted while a download of the motion control parameter settings was in progress. The non-volatile memory is faulty or the life of the non-volatile memory has been exceeded. The MC_ChangeAxisUse (Change Axis Use) instruction was executed for an axis that is set to <i>Unused axis (unchangeable to used axis)</i>. 			S			W508
572F0000 hex (Ver. 1.06 or later)	Motion Control Instruction Multi-execution Disabled (Master Axis)	A <i>Master</i> in-out variable that cannot be changed during multi-execution of instructions was changed.	<ul style="list-style-type: none"> A <i>Master</i> in-out variable that cannot be changed during multi-execution of instructions was changed. 			S			W508
57300000 hex (Ver. 1.06 or later)	Motion Control Instruction Multi-execution Disabled (Position Type Selection)	A <i>ReferenceType</i> in-out variable that cannot be changed during multi-execution of instructions was changed.	<ul style="list-style-type: none"> A <i>ReferenceType</i> in-out variable that cannot be changed during multi-execution of instructions was changed. 			S			W508
573A0000 hex (Ver. 1.08 or later)	Cannot Write Axis Parameters	The instruction was executed for an axis that is not an unused axis.	<ul style="list-style-type: none"> The instruction was executed for a used axis or an undefined axis. 			S			W508
573B0000 hex (Ver. 1.08 or later)	Axis Parameter Setting Out of Range	The parameter specified for the <i>AxisParameter</i> input variable to a motion control instruction is outside of the valid range.	<ul style="list-style-type: none"> The parameter specified for the <i>AxisParameter</i> input variable to the instruction is out of range for the input variable. 			S			W508

Event code	Event name	Meaning	Assumed cause	Level					Reference
				Maj	Prt	Min	Obs	Info	
573C0000 hex (Ver. 1.08 or later)	Cam Property Setting Out of Range	The parameter specified for the <i>CamProperty</i> input variable to a motion control instruction is outside of the valid range.	<ul style="list-style-type: none"> The parameter specified for the <i>CamProperty</i> input variable to the instruction is out of range for the input variable. 			S			W508
573D0000 hex (Ver. 1.08 or later)	Cam Node Setting Out of Range	The parameter specified for the <i>CamNodes</i> input variable to a motion control instruction is outside of the valid range.	<ul style="list-style-type: none"> The parameter specified for the <i>CamNodes</i> input variable to the instruction is out of range for the input variable. 			S			W508
573E0000 hex (Ver. 1.08 or later)	Incorrect Cam Node Type Specification	The parameter specified for the <i>CamNodes</i> input variable to a motion control instruction is not an <code>_sMC_CAM_NODE</code> array variable.	<ul style="list-style-type: none"> The parameter specified for the <i>CamNodes</i> input variable to the instruction is not an <code>_sMC_CAM_NODE</code> array variable. 			S			W508
573F0000 hex (Ver. 1.08 or later)	Insufficient Nodes in Cam Table	The array variable of the parameter specified for the <i>CamNodes</i> input variable to a motion control instruction has a <i>Phase</i> value of 0 for element number 0.	<ul style="list-style-type: none"> The array variable of the parameter specified for the <i>CamNodes</i> input variable to the instruction has a <i>Phase</i> (master axis phase) value of 0 for element number 0. 			S			W508
57400000 hex (Ver. 1.08 or later)	Cam Node Master Axis Phase Not in Ascending Order	The values of <i>Phase</i> in the array variable of the parameter specified for the <i>CamNodes</i> input variable to a motion control instruction are not in ascending order according to the element numbers.	<ul style="list-style-type: none"> The values of <i>Phase</i> (master axis phase) in the array variable of the parameter specified for the <i>CamNodes</i> input variable to the instruction are not in ascending order according to the element numbers. Or, truncating the digits that are not effective more than seven digits caused the phases to not be in ascending order. 			S			W508
57410000 hex (Ver. 1.08 or later)	Too Many Data Points in Cam Table	The number of generated cam data points exceeded the number of elements in the array in the cam data variable that is specified for the <i>CamTable</i> input variable to a motion control instruction.	<ul style="list-style-type: none"> The number of cam data points in the generated cam table exceeded the number of elements in the array in the cam data variable that is specified for the <i>CamTable</i> input variable to the instruction. 			S			W508
57420000 hex (Ver. 1.08 or later)	Cam Table Displacement Overflow	<i>Distance</i> in the generated cam table exceeded the range of REAL data.	<ul style="list-style-type: none"> <i>Distance</i> in the generated cam table exceeded the range of REAL data. 			S			W508

Event code	Event name	Meaning	Assumed cause	Level					Reference
				Maj	Prt	Min	Obs	Info	
57430000 hex (Ver. 1.08 or later)	Aborted Cam Table Used	A cam data variable that was aborted during generation was specified for the <i>CamTable</i> input variable to an instruction.	<ul style="list-style-type: none"> A cam data variable that was aborted during generation due to an error in the <i>MC_GenerateCamTable</i> (Generate Cam Table) instruction was specified for the <i>CamTable</i> input variable to the instruction. 			S			W508
57490000 hex (Ver. 1.10 or later)	Execution ID Setting Out of Range	The parameter specified for the <i>ExecID</i> input variable to a motion control instruction is out of range.	<ul style="list-style-type: none"> The parameter specified for the <i>ExecID</i> input variable to the instruction is out of range for the input variable. 			S			W508
574A0000 hex (Ver. 1.10 or later)	Position Offset Out of Range	The parameter specified for the <i>OffsetPosition</i> input variable to a motion control instruction is out of range.	<ul style="list-style-type: none"> The position offset exceeded the range of signed 40-bit data when it was converted to pulses. 			S			W508
574B0000 hex (Ver. 1.10 or later)	PDS State Transition Command Selection Out of Range	The parameter specified for the <i>TransitionCmd</i> input variable to a motion control instruction is out of range.	<ul style="list-style-type: none"> Instruction input parameter exceeded the valid range of the input variable. 			S			W508
574C0000 hex (Ver. 1.13 or later)	Single-axis Position Control Axis Motion Control Instruction Execution Disabled	An operation instruction was executed for a single-axis position control axis.	<ul style="list-style-type: none"> An operation instruction was executed for a single-axis position control axis. 			S			W508
64400000 hex	Target Position Positive Software Limit Exceeded	The specified position exceeds the positive software limit.	<ul style="list-style-type: none"> The parameter specified for the <i>Position</i> input variable to the instruction is beyond the positive software limit. The first position is beyond the positive software limit and an instruction that specifies motion in the opposite direction of the software limit was executed. The parameter that was specified for the <i>AuxPoint</i> input variable to a border point <i>MC_MoveCircular2D</i> (Circular 2D Interpolation) instruction is beyond the positive software limit. 			S			W508

Event code	Event name	Meaning	Assumed cause	Level					Reference
				Maj	Prt	Min	Obs	Info	
64410000 hex	Target Position Negative Software Limit Exceeded	The specified position exceeds the negative software limit.	<ul style="list-style-type: none"> The parameter specified for the <i>Position</i> input variable to the instruction is beyond the negative software limit. The first position is beyond the negative software limit and an instruction that specifies motion in the opposite direction of the software limit was executed. The parameter that was specified for the <i>AuxPoint</i> input variable to a border point MC_MoveCircular2D (Circular 2D Interpolation) instruction is beyond the negative software limit. 			S			W508
64420000 hex	Command Position Overflow/Underflow	Positioning, an instruction in the underflow/overflow direction, or an instruction for which the direction is not specified was executed when there was an underflow/overflow in the command position.	<ul style="list-style-type: none"> One of the following was executed when there was a command position overflow/underflow. <ul style="list-style-type: none"> A positioning instruction A continuous control instruction in the underflow/overflow direction An instruction for which the direction is not specified (syncing or torque control) 			S			W508
64430000 hex	Positive Limit Input	An instruction was executed for a motion in the positive direction when the positive limit input was ON.	<ul style="list-style-type: none"> An instruction for a motion in the positive direction was executed when the positive limit input was ON, or an instruction for a motion with no direction specification was executed when the positive limit input was ON. An axes group motion control instruction was executed when the positive limit input was ON. 			S			W508
64440000 hex	Negative Limit Input	An instruction for a motion in the negative direction was executed when the negative limit input was ON.	<ul style="list-style-type: none"> An instruction for a motion in the negative direction was executed when the negative limit input was ON, or an instruction for a motion with no direction specification was executed when the negative limit input was ON. An axes group motion control instruction was executed when the negative limit input was ON. 			S			W508
74220000 hex	Servo Main Circuits OFF	An attempt was made to turn ON the Servo when the main circuit power supply to the Servo Drive was OFF.	<ul style="list-style-type: none"> An attempt was made to turn ON the Servo when the main circuit power supply to the Servo Drive was OFF. 			S			W508
57220000 hex (Ver. 1.06 or later)	Actual Position Overflow/Underflow	An instruction was executed that is not supported during an actual position overflow/underflow.	<ul style="list-style-type: none"> An instruction was executed that is not supported during an actual position overflow or underflow. 				S		W508

Event code	Event name	Meaning	Assumed cause	Level					Reference
				Maj	Prt	Min	Obs	Info	
57230000 hex (Ver. 1.06 or later)	Switch Structure Track Number Setting Out of Range	The value of <i>TrackNumber</i> that is specified in the <i>Switches</i> in-out variable to a motion control instruction is out of range.	<ul style="list-style-type: none"> The value of the member of the structure variable that was specified for the in-out variable of the instruction is out of range. 				S		W508
57240000 hex (Ver. 1.06 or later)	Switch Structure First ON Position Setting Out of Range	The value of <i>FirstOnPosition</i> that is specified in the <i>Switches</i> in-out variable to a motion control instruction is out of range.	<ul style="list-style-type: none"> The value of the member of the structure variable that was specified for the in-out variable of the instruction is out of range. 				S		W508
57250000 hex (Ver. 1.06 or later)	Switch Structure Last ON Position Setting Out of Range	The value of <i>LastOnPosition</i> that is specified in the <i>Switches</i> in-out variable to a motion control instruction is out of range.	<ul style="list-style-type: none"> The value of the member of the structure variable that was specified for the in-out variable of the instruction is out of range. 				S		W508
57260000 hex (Ver. 1.06 or later)	Switch Structure Axis Direction Out of Range	The value of <i>AxisDirection</i> that is specified in the <i>Switches</i> in-out variable to a motion control instruction is out of range.	<ul style="list-style-type: none"> The value of the member of the structure variable that was specified for the in-out variable of the instruction is out of range. 				S		W508
57270000 hex (Ver. 1.06 or later)	Switch Structure Cam Switch Mode Out of Range	The value of <i>CamSwitchMode</i> that is specified in the <i>Switches</i> in-out variable to a motion control instruction is out of range.	<ul style="list-style-type: none"> The value of the member of the structure variable that was specified for the in-out variable of the instruction is out of range. 				S		W508
57280000 hex (Ver. 1.06 or later)	Switch Structure Duration Setting Out of Range	The value of <i>Duration</i> that is specified in the <i>Switches</i> in-out variable to a motion control instruction is out of range.	<ul style="list-style-type: none"> The value of the member of the structure variable that was specified for the in-out variable of the instruction is out of range. 				S		W508
57290000 hex (Ver. 1.06 or later)	Track Option Structure ON Compensation Setting Out of Range	The value of <i>OnCompensation</i> that is specified in the <i>TrackOptions</i> in-out variable to a motion control instruction is out of range.	<ul style="list-style-type: none"> The value of the member of the structure variable that was specified for the in-out variable of the instruction is out of range. 				S		W508
572A0000 hex (Ver. 1.06 or later)	Track Option Structure OFF Compensation Setting Out of Range	The value of <i>OffCompensation</i> that is specified in the <i>TrackOptions</i> in-out variable to a motion control instruction is out of range.	<ul style="list-style-type: none"> The value of the member of the structure variable that was specified for the in-out variable of the instruction is out of range. 				S		W508

Event code	Event name	Meaning	Assumed cause	Level					Reference
				Maj	Prt	Min	Obs	Info	
572B0000 hex (Ver. 1.06 or later)	Number of Array Elements in Switch Structure Variable Out of Range	The number of elements in an array in the structure variable that is specified in the <i>Switches</i> in-out variable to a motion control instruction is out of range.	<ul style="list-style-type: none"> The number of elements in an array of the structure variable that was specified for the in-out variable of the instruction is out of range. 				S		W508
572C0000 hex (Ver. 1.06 or later)	Number of Array Elements in Output Signal Structure Variable Out of Range	The number of elements in an array in the structure variable that is specified in the <i>Outputs</i> in-out variable to a motion control instruction is out of range.	<ul style="list-style-type: none"> The number of elements in an array of the structure variable that was specified for the in-out variable of the instruction is out of range. 				S		W508
572D0000 hex (Ver. 1.06 or later)	Number of Array Elements in Track Option Structure Variable Out of Range	The number of elements in an array in the structure variable that is specified in the <i>TrackOptions</i> in-out variable to a motion control instruction is out of range.	<ul style="list-style-type: none"> The number of elements in an array of the structure variable that was specified for the in-out variable of the instruction is out of range. 				S		W508
572E0000 hex (Ver. 1.06 or later)	Numbers of Elements in Output Signals and Track Option Arrays Not Matched	The arrays in the structure variables that are specified for the <i>Outputs</i> and <i>TrackOptions</i> in-out variables to a motion control instruction do not have the same number of elements.	<ul style="list-style-type: none"> The arrays in the output signal structure variable and track option structure variable that are specified for the in-out variables to the instruction do not have the same number of elements. 				S		W508
57310000 hex (Ver. 1.06 or later)	Same Track Number Setting in Switch Structure Out of Range	The same track number was specified more than the allowable number of times for the <i>TrackNumber</i> in the <i>Switches</i> in-out variable to a motion control instruction.	<ul style="list-style-type: none"> The same track number was specified more than the allowable number of times for the <i>TrackNumber</i> in the <i>Switches</i> in-out variable to a motion control instruction. 				S		W508

3-1-5 Errors in the EtherNet/IP Function Module

Built-in EtherNet/IP Port on CPU Unit

The manual names are given below for the catalog numbers given in the *Reference* column of the event table.

Cat. No.	Manual name
W506	NJ/NX-series CPU Unit Built-in EtherNet/IP Port User's Manual

Event code	Event name	Meaning	Assumed cause	Level					Reference
				Maj	Prt	Min	Obs	Info	
04200000 hex	Communications Controller Failure	A hardware error was detected in the communications controller of the built-in EtherNet/IP port.	<ul style="list-style-type: none"> Communications Controller hardware error 		S				W506
14200000 hex	MAC Address Error	The MAC address in non-volatile memory was not read correctly.	<ul style="list-style-type: none"> Non-volatile memory failure 		S				W506
14220000 hex	EtherNet/IP Processing Error	A fatal error was detected in the EtherNet/IP Function Module.	<ul style="list-style-type: none"> Hardware has failed. 		S				W506
34210000 hex	Basic Ethernet Setting Error	An error was detected in the Ethernet settings.	<ul style="list-style-type: none"> Setting error Power was interrupted when a download was in progress for the built-in EtherNet/IP port settings. Memory error 		S				W506
34220000 hex	IP Address Setting Error	An error was detected in the IP address settings.	<ul style="list-style-type: none"> Setting error Power was interrupted when a download was in progress for the built-in EtherNet/IP port settings. Memory error The IP address acquired from BOOTP server is illegal. 		S				W506
84010000 hex	IP Address Duplication Error	The same IP address is used more than once.	<ul style="list-style-type: none"> The IP address of the built-in EtherNet/IP port is also used as the IP address of another node. 		S				W506
84020000 hex	BOOTP Server Connection Error	Connection with the BOOTP server failed.	<ul style="list-style-type: none"> Server setting error Server is down. An error occurred in the communications path. 		S				W506
04210000 hex (Ver. 1.10 or later)	Communications Controller Failure	A hardware error was detected in the communications controller of the built-in EtherNet/IP port.	<ul style="list-style-type: none"> Hardware error in the communications controller 			S			W506
14210000 hex	Identity Error	The CIP identity information in non-volatile memory was not read correctly.	<ul style="list-style-type: none"> Non-volatile memory failure 			S			W506

Event code	Event name	Meaning	Assumed cause	Level					Reference
				Maj	Prt	Min	Obs	Info	
14230000 hex (Ver. 1.10 or later)	MAC Address Error	The MAC address in non-volatile memory was not read correctly.	<ul style="list-style-type: none"> Non-volatile memory failure 			S			W506
34200000 hex	Tag Data Link Setting Error	An error was detected in the communications settings for tag data links.	<ul style="list-style-type: none"> Power was interrupted when a download was in progress for the data link settings. Memory error 			S			W506
34230000 hex	IP Route Table Setting Error	An IP routing setting error was detected.	<ul style="list-style-type: none"> Setting error Power was interrupted when a download was in progress for the built-in EtherNet/IP port settings. Memory error 			S			W506
34240000 hex	FTP Server Setting Error	An error was detected in the FTP server settings.	<ul style="list-style-type: none"> Setting error Power was interrupted when a download was in progress for the FTP server settings. Memory error 			S			W506
34250000 hex	NTP Client Setting Error	An error was detected in the NTP client settings.	<ul style="list-style-type: none"> Setting error Power was interrupted when a download was in progress for the NTP client settings. Memory error 			S			W506
34260000 hex	SNMP Setting Error	An error was detected in the SNMP agent/trap settings.	<ul style="list-style-type: none"> Setting error Power was interrupted when a download was in progress for the SNMP agent/trap settings. Memory error 			S			W506
34270000 hex	Tag Name Resolution Error	Resolution of a tag used in a tag data link failed.	<ul style="list-style-type: none"> The size of the network variable is different from the tag settings. The I/O direction set for a tag data link and the I/O direction of the Controller variable do not match. There are no network variables for the Controller tag settings. A variable in the Controller that is set for a tag data link has the Network Publish attribute set to Input but also has the Constant attribute. 			S			W506
34280000 hex (Ver. 1.10 or later)	Basic Ethernet Setting Error	An error was detected in the Ethernet settings.	<ul style="list-style-type: none"> Parameter error Power was interrupted when a download was in progress for the built-in EtherNet/IP port settings. A memory error occurred. 			S			W506
34290000 hex (Ver. 1.10 or later)	IP Address Setting Error	An error was detected in the IP address settings.	<ul style="list-style-type: none"> Parameter error Power was interrupted when a download was in progress for the built-in EtherNet/IP port settings. The IP address acquired from BOOTP server is illegal. A memory error occurred. 			S			W506

Event code	Event name	Meaning	Assumed cause	Level					Reference
				Maj	Prt	Min	Obs	Info	
342A0000 hex (Ver. 1.10 or later)	DNS Setting Error	An error was detected in the DNS settings or Hosts settings.	<ul style="list-style-type: none"> Parameter error Power was interrupted when a download was in progress for the built-in EtherNet/IP port settings. A memory error occurred. 			S			W506
50010000 hex (Ver. 1.02 or later)	Controller Insufficient Memory Warning	The amount of data for the EtherCAT slave configuration, network-published information, or other data exceeds the value that is specified for the CPU Unit. You may not be able to perform online editing or other operations.	<ul style="list-style-type: none"> The amount of data for the EtherCAT slave configuration, network-published information, or other data exceeds the value that is specified for the CPU Unit. 			S			W506
84030000 hex	DNS Server Connection Error	Connection with the DNS server failed.	<ul style="list-style-type: none"> Parameter error Server is down. An error occurred in the communications path. 			S			W506
84040000 hex	NTP Server Connection Error	Connection with the NTP server failed.	<ul style="list-style-type: none"> Parameter error Server is down. An error occurred in the communications path. 			S			W506
84070000 hex	Tag Data Link Connection Failed	Establishing a tag data link connection failed.	<ul style="list-style-type: none"> The tag data link connection information is not the same for the originator and target. Insufficient connections 			S			W506
84080000 hex	Tag Data Link Timeout	A timeout occurred in a tag data link.	<ul style="list-style-type: none"> The power supply to the target node is OFF. Communications with the target node stop. The Ethernet cable for EtherNet/IP is disconnected. The Ethernet cable for EtherNet/IP is broken. Noise The link to the built-in EtherNet/IP port is OFF. 			S			W506
84090000 hex (Ver. 1.04 or later)	Tag Data Link Connection Timeout	A timeout occurred while trying to establish a tag data link connection.	<ul style="list-style-type: none"> The power supply to the target node is OFF. Communications at the target node are stopped. The Ethernet cable connector for EtherNet/IP is disconnected. The Ethernet cable for EtherNet/IP is broken. An error occurred in the communications path. 			S	U		W506
840A0000 hex (Ver. 1.10 or later)	IP Address Duplication Error	The same IP address is used more than once.	<ul style="list-style-type: none"> The IP address of the built-in EtherNet/IP port is also used as the IP address of another node. 			S			W506
840B0000 hex (Ver. 1.10 or later)	BOOTP Server Connection Error	Connection with the BOOTP server failed.	<ul style="list-style-type: none"> Server setting error The server is down. An error occurred in the communications path. 			S			W506

Event code	Event name	Meaning	Assumed cause	Level					Reference
				Maj	Prt	Min	Obs	Info	
840C0000 hex (Ver. 1.10 or later)	Tag Data Link Equipment Total Allowable Bandwidth Exceeded	The total bandwidth for the connections that are set or established exceeded the allowable tag data link bandwidth for all of the EtherNet/IP ports in the equipment.	<ul style="list-style-type: none"> An attempt was made to establish a connection that would cause the PPS total of the packet transfer rates of the tag data links that use the EtherNet/IP ports in the equipment to exceed the allowable bandwidth of the equipment. 			S			W506
54E00000 hex	Access Detected Outside Range of Variable	Accessing a value that is out of range was detected for a tag variable that is used in a tag data link.	<ul style="list-style-type: none"> An out-of-range value was written by an EtherNet/IP tag data link for a variable with a specified range. A value that does not specify an enumerator was written by an EtherNet/IP tag data link for an enumeration variable. 				S		W506
84050000 hex	Packet Discarded Due to Full Reception Buffer	A packet was discarded.	<ul style="list-style-type: none"> A network convergence occurred. 				S		W506
84060000 hex	Link OFF Detected	An Ethernet Link OFF was detected.	<ul style="list-style-type: none"> An Ethernet cable is broken, disconnected, or loose. The Ethernet switch's power supply is turned OFF. Baud rate mismatch. Noise The Identity object was reset. Settings for EtherNet/IP were downloaded from the Network Configurator or Sysmac Studio, or the Clear All Memory operation was performed. 			U	S		W506
94010000 hex	Tag Data Link Download Started	Changing the tag data link settings started.	<ul style="list-style-type: none"> Changing the tag data link settings started. 					S	W506
94020000 hex	Tag Data Link Download Finished	Changing the tag data link settings finished.	<ul style="list-style-type: none"> Changing the tag data link settings finished. 					S	W506
94030000 hex	Tag Data Link Stopped	Tag data links were stopped by the Network Configurator, Sysmac Studio, or manipulation of a system-defined variable. Or, the data link table was downloaded from the Network Configurator or Sysmac Studio again.	<ul style="list-style-type: none"> Tag data links were stopped by the Network Configurator, Sysmac Studio, or manipulation of a system-defined variable. 					S	W506

Event code	Event name	Meaning	Assumed cause	Level					Reference
				Maj	Prt	Min	Obs	Info	
94040000 hex	Tag Data Link Started	Tag data links were started by the Network Configurator, Sysmac Studio, or manipulation of a system-defined variable. Or, the data link table was downloaded from the Network Configurator or Sysmac Studio again.	<ul style="list-style-type: none"> Tag data links were started by the Network Configurator, Sysmac Studio, or manipulation of a system-defined variable. 					S	W506
94050000 hex	Link Detected	Establishment of an Ethernet link was detected.	<ul style="list-style-type: none"> Establishment of an Ethernet link was detected. 					S	W506
94060000 hex	Restarting Ethernet Port	The built-in EtherNet/IP port was restarted.	<ul style="list-style-type: none"> The built-in EtherNet/IP port was restarted. 					S	W506
94070000 hex	Tag Data Link All Run	Tag data link connections to all nodes have been established.	<ul style="list-style-type: none"> Tag data link connections to all target nodes have been established. 					S	W506
94080000 hex	IP Address Fixed	The correct IP address has been determined and Ethernet communications can start.	<ul style="list-style-type: none"> The correct IP address has been determined and Ethernet communications can start. 					S	W506
94090000 hex	BOOTP Client Started	The BOOTP client started requesting an IP address.	<ul style="list-style-type: none"> The BOOTP client started requesting an IP address. 					S	W506
940A0000 hex	FTP Server Started	The FTP agent started normally.	<ul style="list-style-type: none"> The FTP agent started normally. 					S	W506
940B0000 hex	NTP Client Started	The NTP client started normally and a request for the NTP server to obtain the time started.	<ul style="list-style-type: none"> The NTP client started normally and a request for the NTP server to obtain the time started. 					S	W506
940C0000 hex	SNMP Started	The SNMP agent started normally.	<ul style="list-style-type: none"> The SNMP agent started normally. 					S	W506

3-1-6 Errors in the EtherCAT Master Function Module

Built-in EtherCAT Master in CPU Unit

The manual names are given below for the catalog numbers given in the *Reference* column of the event table.

Cat. No.	Manual name
W505	NJ/NX-series CPU Unit Built-in EtherCAT Port User's Manual

Event code	Event name	Meaning	Assumed cause	Level					Reference
				Maj	Prt	Min	Obs	Info	
04400000 hex	Communications Controller Failure	An error was detected in the hardware test at startup.	<ul style="list-style-type: none"> The CPU Unit has failed. 		S				W505

Event code	Event name	Meaning	Assumed cause	Level					Reference
				Maj	Prt	Min	Obs	Info	
14400000 hex	MAC Address Error	The MAC address is incorrect.	<ul style="list-style-type: none"> The CPU Unit has failed. 		S				W505
44010000 hex	EtherCAT Fault	A fatal error was detected in the EtherCAT Master Function Module.	<ul style="list-style-type: none"> Software is corrupted. 		S				W505
84200000 hex	Link OFF Error	A Link OFF state occurred.	<ul style="list-style-type: none"> The Ethernet cable is broken between the master and slaves. The Ethernet cable connector is disconnected. The Ethernet cable is not connected. 		S				W505
842E0000 hex (Ver. 1.11 or later)	EtherCAT Frame Not Received	The sent EtherCAT frame was not received.	<ul style="list-style-type: none"> A Unit other than an EtherCAT slave is connected. A connector on the Ethernet cable is disconnected, the contact is faulty, or parts are faulty. Slave output ports are connected to each other. The master and slave are connected with the slave output port. Hardware failure of EtherCAT slave Hardware failure of EtherCAT master 		S				W505
24200000 hex	Slave Node Address Duplicated	The same slave address is used for two nodes.	<ul style="list-style-type: none"> The same node address is set for more than one slave. 			S			W505
34400000 hex	Network Configuration Information Error	There is an error in the network configuration information.	<ul style="list-style-type: none"> The power supply to the Controller was interrupted or communications with the Sysmac Studio were disconnected while downloading the network configuration information. 			S			W505
34410000 hex (Ver. 1.10 or later)	EtherCAT Communications Cycle Exceeded	Process data communications could not be performed with the specified communications cycle.	<ul style="list-style-type: none"> The transmission delay time in the actually connected configuration is longer than the transmission delay time calculated for the user-set cable length. The set task period or communications cycle is too short. 			S			W505
50010000 hex (Ver. 1.02 or later)	Controller Insufficient Memory Warning	The amount of data for the EtherCAT slave configuration, network-published information, or other data exceeds the value that is specified for the CPU Unit. You may not be able to perform online editing or other operations.	<ul style="list-style-type: none"> The amount of data for the EtherCAT slave configuration, network-published information, or other data exceeds the value that is specified for the CPU Unit. 			S			W505

Event code	Event name	Meaning	Assumed cause	Level					Reference
				Maj	Prt	Min	Obs	Info	
84210000 hex	Network Configuration Error	The EtherCAT network configuration is incorrect.	<ul style="list-style-type: none"> Slave output ports are connected to each other. The master and slave are connected with the slave output port. The number of connected slaves exceeded the maximum number of slaves for the EtherCAT master. 			S			W505
84220000 hex	Network Configuration Verification Error	A slave that is in the network configuration information is not connected. Or, a slave that is not in the network configuration information is connected.	<ul style="list-style-type: none"> A slave that is in the network configuration information is not connected. There is a node address mismatch. A different slave from the one that is specified in the network configuration information is connected. A slave that is not in the network configuration information is connected. The hardware switches for the slave node address were changed to a value other than 0 after the <i>Write Slave Node Address</i> operation was performed from the Sysmac Studio. The Ethernet physical layer is broken between two slaves. 			S			W505
84230000 hex	Slave Initialization Error	Slave initialization failed.	<ul style="list-style-type: none"> An error occurred in EtherCAT master processing. An initialization error occurred in the EtherCAT slave. An initialization error occurred in the EtherCAT Coupler Unit. A major fault level Controller error occurred. The Ethernet cable is broken or the specified cable is not being used. A connector on the Ethernet cable is disconnected, the contact is faulty, or parts are faulty. A general-purpose Ethernet hub is connected. The master failed. The slave failed. Noise. 			S			W505
84280000 hex	Slave Application Error	An error occurred in the slave application.	<ul style="list-style-type: none"> An error was detected in the slave's application layer status register. 			S			W505
84290000 hex	Process Data Transmission Error	Sending process data failed.	<ul style="list-style-type: none"> It was not possible to send the EtherCAT frame during the EtherCAT communications period. The frame transmission jitter exceeded the limit. 			S			W505

Event code	Event name	Meaning	Assumed cause	Level					Reference
				Maj	Prt	Min	Obs	Info	
842B0000 hex	Process Data Reception Timeout	Process data reception timed out.	<ul style="list-style-type: none"> The Ethernet cable is broken or the specified cable is not being used. A connector on the Ethernet cable is disconnected, the contact is faulty, or parts are faulty. A general-purpose Ethernet hub is connected. The master failed. The slave failed. The Ethernet cable is too long. The CPU Unit task period is too short. Noise 			S			W505
842C0000 hex	Process Data Communications Error	An error occurred in process data communications.	<ul style="list-style-type: none"> A slave left the network even though the disconnection operation or disable operation was not performed. The slave failed. 			S			W505
842F0000 hex (Ver. 1.13 or later)	Input Process Data Invalid Error	<p>Because the EtherCAT master could not perform process data communications normally when it was in the Operational state, the Input Data Invalid state continued for the following period.</p> <ul style="list-style-type: none"> When the task period is 10 ms or shorter: 100 ms When the task period is longer than 10 ms: 10 periods of the task 	<ul style="list-style-type: none"> Hardware failure of EtherCAT slave Noise 			S			W505
102F0000 hex (Ver. 1.03 or later)	EtherCAT Slave Backup Failed	The backup operation for an EtherCAT slave ended in an error.	<ul style="list-style-type: none"> There is no connection between the EtherCAT master and the slave (Link OFF). An error caused an incorrect EtherCAT master status. The EtherCAT network configuration information does not agree with the physical network configuration. The request to the EtherCAT slave failed. The EtherCAT master was temporarily unable to perform the processing because it was executing other processing. Initialization of the EtherCAT slave failed. It was not possible to read the backup parameters from the EtherCAT slave. Communications with an OMRON Communications Coupler Unit or NX Unit failed. 				S		W505

Event code	Event name	Meaning	Assumed cause	Level					Reference
				Maj	Prt	Min	Obs	Info	
10300000 hex (Ver. 1.03 or later)	EtherCAT Slave Restore Operation Failed	The restore operation for an EtherCAT slave ended in an error.	<ul style="list-style-type: none"> There is no connection between the EtherCAT master and the slave (Link OFF). An error caused an incorrect EtherCAT master status. The EtherCAT network configuration information does not agree with the physical network configuration. The request to the EtherCAT slave failed. The EtherCAT master was temporarily unable to perform the processing because it was executing other processing. Initialization of the EtherCAT slave failed. It was not possible to write the backup parameters to the MX2/RX Series Inverter. (This applies only for unit version 1.10 or earlier of the CPU Unit.) It was not possible to write the backup parameters to the EtherCAT slave. Incorrect backup data was detected. The EtherCAT network configuration in the backup data does not agree with the physical network configuration. An error occurred at an OMRON Communications Coupler Unit. The following causes are possible. <ul style="list-style-type: none"> Reading a backup file failed at the Communications Coupler Unit (when attached information 4 is 1). Communications with the Communications Coupler Unit or NX Unit failed (when attached information 4 is 2). The Unit Configuration of the NX Units in the Communications Coupler Unit when data was backed up did not agree with the actual configuration of NX Units (when attached information 4 is 3). 				S		W505
64200000 hex	Emergency Message Detected	An emergency message was detected.	<ul style="list-style-type: none"> An emergency message was received from a slave. 				S		W505
842D0000 hex	EtherCAT Message Error	An error occurred in a message communications with the slave.	<ul style="list-style-type: none"> Refer to the attached information to check the error. 				S		W505
94400000 hex	Slave Disconnected	A slave was disconnected for a disconnection command.	<ul style="list-style-type: none"> An operation to disconnect the slave was executed from the Sysmac Studio. The EC_DisconnectSlave instruction was executed. 					S	W505

Event code	Event name	Meaning	Assumed cause	Level					Reference
				Maj	Prt	Min	Obs	Info	
94410000 hex	Slave Connected	A slave was reconnected for a reconnection command.	<ul style="list-style-type: none"> An operation to reconnect the slave was executed from the Sysmac Studio. The EC_ConnectSlave instruction was executed. 					S	W505
94430000 hex	Errors Reset	A command was received to reset errors.	<ul style="list-style-type: none"> An error reset operation was performed from the Sysmac Studio. The ResetECError instruction was executed. 					S	W505
94440000 hex (Ver. 1.04 or later)	Slave Disabled	The EtherCAT Slave was disabled.	<ul style="list-style-type: none"> The EC_ChangeEnableSetting instruction was executed. 					S	W505
94450000 hex (Ver. 1.04 or later)	Slave Enabled	The EtherCAT Slave was enabled.	<ul style="list-style-type: none"> The EC_ChangeEnableSetting instruction was executed. 					S	W505
94500000 hex (Ver. 1.11 or later)	EtherCAT Diagnosis/Statistics Log Started	EtherCAT diagnosis/statistics log is started.	<ul style="list-style-type: none"> The value of the <code>_EC_StatisticsLogEnable</code> system-defined variable changed from FALSE to TRUE. 					S	W505
94510000 hex (Ver. 1.11 or later)	EtherCAT Diagnosis/Statistics Log Ended	EtherCAT diagnosis/statistics log is ended.	<ul style="list-style-type: none"> An error that causes EtherCAT diagnosis/statistics log to end occurred. 					S	W505

3-1-7 Errors in OPC UA

The section provides tables of the errors (events) that can occur in the OPC UA.

Refer to the *NJ-series CPU Unit OPC UA User's Manual* (Cat. No. W588) for information on the unit versions of the CPU Units and the corresponding Sysmac Studio versions.

The manual names are given below for the catalog numbers given in the *Reference* column of the event table.

Cat. No.	Manual name
W588	NJ-series CPU Unit OPC UA User's Manual

Errors Related to OPC UA Server

Event code	Event name	Meaning	Assumed cause	Level					Reference
				Maj	Prt	Min	Obs	Info	
15000000 hex	Execution Log Save Failed	Failed to save the Execution Log to the SD Memory Card.	<ul style="list-style-type: none"> An SD Memory Card is not inserted. The SD Memory Card type is not correct. The format of the SD Memory Card is not correct. The SD Memory Card is write protected. The SD Memory Card does not have sufficient available space. The SD Memory Card is damaged. 			S	U		W588

Event code	Event name	Meaning	Assumed cause	Level					Reference
				Maj	Prt	Min	Obs	Info	
15020000 hex	Server Certificate Mismatch	The IP address of the server certificate in the CPU Unit is not the same as that of the built-in EtherNet/IP port on the CPU Unit.	The IP address of the built-in EtherNet/IP port of the CPU Unit was changed when Server Use Option is set to "Use". <ul style="list-style-type: none"> The IP address was changed by the ChangeIPAdr (Change IP Address) instruction. If the IP address setting method was "Obtain from BOOTP server", the IP address was changed when the power is turned ON. A project containing the changed IP address of the built-in EtherNet/IP port of the CPU Unit was downloaded to the CPU Unit. 				S		W588
35D00000 hex	OPC UA Server Setting Error	The OPC UA Server Settings are incorrect.	<ul style="list-style-type: none"> The power supply to the Controller was interrupted while transferring the OPC UA Server Settings. The power supply to the Controller was interrupted during a Clear All Memory operation. The OPC UA Server settings are not correct because the Controller was interrupted during a restore operation. TCP port number is duplicated. 			S			W588
35D10000 hex	Server certificate Expired	The period of the server certificate expired.	<ul style="list-style-type: none"> The period that is set in the server certificate expired. 			S	U		W588
35D20000 hex	Server Certificate Expiration Notice	The period of the server certificate is close to expiring.	<ul style="list-style-type: none"> The period that is set in the server certificate is close to expiring. 			U	S		W588
35D30000 hex	Too Many Public Variables	The number of variables that can be published to the OPC UA client exceeded the upper limit when preparing the OPC UA Server.	<ul style="list-style-type: none"> When the OPC UA Server prepares the address space, the number of OPC UA variables exceeds the upper limit. 				S		W588

Event code	Event name	Meaning	Assumed cause	Level					Reference
				Maj	Prt	Min	Obs	Info	
35D40000 hex	Unsupported Data Type	When preparing the OPC UA Server, there was a data type variable that cannot be published to the OPC UA client among the network-published global variables.	The OPC UA Server had an unsupported data type in the network-published global variables. Unsupported data types are as follows. Unsupported data types and limit values are as follows: <ul style="list-style-type: none"> Multidimensional array specified structure Structure containing multidimensional array(s) as member(s) Structure whose nesting number exceeds the limit value Union Array whose start number is not 0; e.g., Array[2..5] Variable whose size exceeds the limit value Array whose number of elements exceeds the limit value Structure whose number of members exceeds the limit value 				S		W588
35D50000 hex	Too Many Public Value Attributes	The number of value attributes to be published to the OPC UA client exceeded the upper limit when preparing the OPC UA Server.	<ul style="list-style-type: none"> When the OPC UA Server prepares the address space, the number of OPC UA value attributes exceeds the upper limit. 				S		W588
35D60000 hex	Too Many Structure Definitions	The number of structure definitions to be published to the OPC UA client exceeded the upper limit when preparing the OPC UA Server.	<ul style="list-style-type: none"> When the OPC UA Server prepares the address space, the number of structure definitions exceeds the upper limit. 				S		W588
44180000 hex	OPC UA System Processing Error	A fatal error was detected in the OPC UA Server.	<ul style="list-style-type: none"> An error occurred in the software. 			S			W588
85600000 hex	OPC UA Client Connection Rejected	A connection request from an OPC UA client was rejected.	<ul style="list-style-type: none"> User authentication information was incorrect. The client certificate was incorrect. The client certificate was registered in the rejected certificate list. The CA certificate is not registered in the trusted certificate list of the client certificate or issuer certificate. The number of sessions exceeds the maximum number of connectable sessions. 				S		W588
95D00000 hex	OPC UA Server Started	The OPC UA Server started.	<ul style="list-style-type: none"> The OPC UA Server started. 					S	W588
95D10000 hex	OPC UA Server Stopped	The OPC UA Server stopped.	<ul style="list-style-type: none"> The OPC UA Server stopped. 					S	W588

Event code	Event name	Meaning	Assumed cause	Level					Reference
				Maj	Prt	Min	Obs	Info	
95D20000 hex	Server Certificate Generated	A server certificate was generated. The server certificate is automatically generated when there is no server certificate, The server certificate is generated when regenerating the server certificate,	<ul style="list-style-type: none"> A server certificate was generated. 					S	W588
95D30000 hex	Client Certificate Discarded	Received client certificates were discarded	<ul style="list-style-type: none"> The maximum number of client certificates that can be registered in the rejected certificate list has been exceeded. 					S	W588
95D40000 hex	OPC UA Server Certificate and Security Profile Cleared	The OPC UA Server certificate and Security Profile has been deleted.	<ul style="list-style-type: none"> A restore was executed using a backup file created by a CPU Unit with a Unit version that does not have OPC UA Server A project that does not have OPC UA Server was downloaded to the CPU Unit. Checked "Clearing the OPC UA server certificate and security profile." and performed Clear All Memory operation. 					S	W588

OPC UA Instructions

The lower four digits of the following event codes indicate the instruction error codes. For descriptions of an error code, refer to the description of the corresponding event code. For example, if the error code for the instruction is 16#5000, refer to the description for event code 54015000 hex.

Event code	Event name	Meaning	Assumed cause	Level					Reference
				Maj	Prt	Min	Obs	Info	
54015000 hex	OPC UA Server Terminated or Being Terminated	The OPC UA Server was already terminated or was being terminated.	<ul style="list-style-type: none"> The OPCUA_Shutdown instruction was executed while the OPC UA Server was already terminated. The OPCUA_Shutdown instruction was executed while the OPC UA Server was being terminated. 				S		W588
54015001 hex	OPC UA Server Being Initialized	The OPCUA_Shutdown instruction could not be executed because the OPC UA Server was being initialized.	<ul style="list-style-type: none"> The OPCUA_Shutdown instruction was executed while the OPC UA Server was being initialized. 				S		W588
54015002 hex	OPC UA Server Not Started	The relevant instruction could not be executed because the OPC UA Server had not been started.	<ul style="list-style-type: none"> When the Server Use Option is set to "Do not use", the relevant instruction was executed. 				S		W588

3-1-8 Errors in the DB Connection Service Function

The section provides tables of the errors (events) that can occur in the DB connection service or DB connection instructions.

Refer to the *NJ/NX-series Database Connection CPU Units User's Manual* (Cat. No. W527) for details on the CPU Unit models and the unit versions in which the DB connection service and DB connection instructions can be used.

The errors are divided into the following functional groups.

- DB connection service
- DB connection instructions

Errors Related to DB Connection Service

The manual names are given below for the catalog numbers given in the *Reference* column of the event table.

Cat. No.	Manual name
W527	NJ/NX-series Database Connection CPU Units User's Manual

Event code	Event name	Meaning	Assumed cause	Level					Reference
				Maj	Prt	Min	Obs	Info	
14D00000 hex	Spool Memory Corrupted	The Spool memory is corrupted.	<ul style="list-style-type: none"> • The user application made an invalid writing to the Spool memory. 			S			W527
14D20000 hex	Execution Log Save Failed	Failed to save the Execution Log to the SD Memory Card.	<ul style="list-style-type: none"> • An SD Memory Card is not inserted. • The SD Memory Card is not the correct type of card. • The format of the SD Memory Card is not correct. • The SD Memory Card is write-protected. • The capacity of the SD Memory Card is insufficient. • The SD Memory Card is damaged. 			S	U		W527
14D30000 hex	SQL Execution Failure Log Save Failed	Failed to save the SQL Execution Failure Log to the SD Memory Card.	<ul style="list-style-type: none"> • An SD Memory Card is not inserted. • The SD Memory Card is not the correct type of card. • The format of the SD Memory Card is not correct. • The SD Memory Card is write-protected. • The capacity of the SD Memory Card is insufficient. • The SD Memory Card is damaged. 			S	U		W527

Event code	Event name	Meaning	Assumed cause	Level					Reference
				Maj	Prt	Min	Obs	Info	
35300000 hex	DB Connection Setting Error	The DB Connection settings are not correct.	<ul style="list-style-type: none"> The power supply to the Controller was interrupted during a download of the DB Connection settings. The DB Connection settings are not correct because the power supply to the Controller was interrupted during a Clear All Memory operation. The DB Connection settings are not correct because the power supply to the Controller was interrupted during a Restore operation. Non-volatile memory failed. 			S			W527
85100000 hex	DB Connection Disconnected Error	The DB Connection was disconnected due to an error.	<ul style="list-style-type: none"> The power supply to the server is OFF. The DB is stopped in the server. The Ethernet cable connector is disconnected. The Ethernet cable is broken. Noise 			S			W527
95300000 hex	DB Connection Service Started	The DB Connection Service was started.	<ul style="list-style-type: none"> The DB Connection Service was successfully started. 					S	W527
95310000 hex	DB Connection Service Stopped	The DB Connection Service was stopped.	<ul style="list-style-type: none"> The DB Connection Service was stopped. 					S	W527
95320000 hex	DB Connection Service Shutdown	The DB Connection Service was shut down.	<ul style="list-style-type: none"> The DB Connection Service was shut down for turning OFF the power supply safely. 					S	W527

DB Connection Instructions

The lower four digits of the following event codes indicate the instruction error codes. For descriptions of an error code, refer to the description of the corresponding event code. For example, if the error code for the instruction is 16#3000, refer to the description for event code 54013000 hex.

The manual names are given below for the catalog numbers given in the *Reference* column of the event table.

Cat. No.	Manual name
W527	NJ/NX-series Database Connection CPU Units User's Manual

Event code	Event name	Meaning	Assumed cause	Level					Reference
				Maj	Prt	Min	Obs	Info	
54013000 hex	DB Connection Service Not Started	The DB Connection Service has not been started.	<ul style="list-style-type: none"> A command to start the DB Connection Service was not given before the execution of relevant instruction. A command to stop the DB Connection Service was given before the execution of relevant instruction. 				S		W527
54013001 hex	DB Connection Service Run Mode Change Failed	Failed to change the Run mode of the DB Connection Service.	<ul style="list-style-type: none"> Run mode change to Test Mode was executed by the relevant instruction while running in Operation Mode. Run mode change to Operation Mode was executed by the relevant instruction while running in Test Mode. Start of the DB Connection Service was commanded while the DB Connection Service was being stopped. Shutdown of the DB Connection Service was commanded while the DB Connection Service was being stopped. 				S		W527
54013002 hex	DB Connection Service Shutdown or Shutting Down	The DB Connection Service is already shut down or being shut down.	<ul style="list-style-type: none"> The relevant instruction was executed after the DB Connection Service was shut down. The relevant instruction was executed while the shutdown processing of the DB Connection Service was in progress. 				S		W527
54013003 hex	Invalid DB Connection Name	The specified DB Connection Name is not set in any DB Connection settings.	<ul style="list-style-type: none"> The DB Connection Name specified in the <i>DBConnection-Name</i> input variable of the relevant instruction is wrong. The DB Connection Name set in the DB Connection settings is wrong. 				S		W527
54013004 hex	DB Connection Rejected	The DB rejected the connection.	<ul style="list-style-type: none"> The user name or password set in the DB Connection settings is wrong. 				S		W527

Event code	Event name	Meaning	Assumed cause	Level					Reference
				Maj	Prt	Min	Obs	Info	
54013005 hex	DB Connection Failed	Failed to connect to the DB.	<ul style="list-style-type: none"> A server does not exist for the specified IP address or the specified host name. The power supply to the server is OFF. The DB is stopped in the server. The Ethernet cable connector is disconnected. The Ethernet cable is broken. 				S		W527
54013006 hex	DB Connection Already Established	A same-name DB Connection is already established.	<ul style="list-style-type: none"> The relevant instruction was executed when a same-name DB Connection was already established. 				S		W527
54013007 hex	Too Many DB Connections	The number of DB Connections that can be established at the same time is exceeded.	<ul style="list-style-type: none"> The relevant instruction was executed when the maximum number of DB Connections that can be established at the same time were already established. 				S		W527
54013008 hex	Invalid DB Connection	The specified DB Connection is not correct, or the DB Connection is already closed.	<ul style="list-style-type: none"> The DB Connection specified in the <i>DBConnection</i> input variable of the relevant instruction is wrong. The DB Connection specified in the <i>DBConnection</i> input variable of the relevant instruction is closed. 				S		W527
54013009 hex	Invalid DB Map Variable	The specified DB Map Variable is not correct.	<ul style="list-style-type: none"> A structure variable that contains a derivative data type of member was specified as a DB Map Variable. A non-structure variable was specified as a DB Map Variable. A structure array variable was specified as a DB Map Variable for INSERT or UPDATE. 				S		W527
5401300A hex	Unregistered DB Map Variable	The specified DB Map Variable has not been registered.	<ul style="list-style-type: none"> The DB Map Variable has not been created by a <i>DB_Create-Mapping</i> instruction. A variable that is not registered as a DB Map Variable was specified in <i>MapVar</i>. The DB Connection specified in the relevant instruction is different from the one specified at the execution of <i>DB_Create-Mapping</i> instruction. 				S		W527

Event code	Event name	Meaning	Assumed cause	Level					Reference
				Maj	Prt	Min	Obs	Info	
5401300B hex	SQL Execution Error	The executed SQL statement resulted in an error.	<ul style="list-style-type: none"> There is no column with the same name as a structure member of the DB Map Variable. The table specified in the DB_CreateMapping instruction does not exist in the DB. One or more structure member values of the DB Map Variable cannot be converted to the corresponding column's data type. One or more column values cannot be converted to the corresponding structure member's data type of the DB Map Variable. One or more structure member values of the DB Map Variable exceed the valid range of the corresponding column's data type. The column specified in the extraction condition does not exist in the DB's records. (DB_Select instruction, DB_Update instruction, DB_Delete instruction) The extraction condition has a syntax error. (DB_Select instruction, DB_Update instruction, DB_Delete instruction) The column specified in the sort condition does not exist in the DB's records. (DB_Select instruction) The sort condition has a syntax error. (DB_Select instruction) The user does not have the access rights to the table. 				S		W527
5401300C hex	Spool Capacity Exceeded	The SQL statement could not be stored in the Spool memory because its maximum capacity was exceeded.	<ul style="list-style-type: none"> The DB connection failure has been continuing due to network failure or other factors. The resend processing of the SQL statements stored in the Spool memory has not been executed (when the <i>Resend spool data</i> parameter is set to <i>Manual</i>). 				S		W527
5401300E hex	Invalid Extraction Condition	The entered extraction condition is invalid.	<ul style="list-style-type: none"> A text string that consists of a NULL (16#00) character only was specified in the <i>Where</i> input variable. 				S		W527
54013010 hex	Log Code Out of Range	The value of the entered log code is outside the valid range.	<ul style="list-style-type: none"> A value outside the valid range from 0 to 9999 was specified. 				S		W527

Event code	Event name	Meaning	Assumed cause	Level					Reference
				Maj	Prt	Min	Obs	Info	
54013011 hex	DB Connection Disconnected Error Status	The instruction could not be executed because the DB Connection had been disconnected due to an error.	<ul style="list-style-type: none"> The power supply to the server is OFF. The DB is stopped in the server. The Ethernet cable connector is disconnected. The Ethernet cable is broken. Noise 				S		W527
54013012 hex	DB Connection Instruction Execution Timeout	The instruction was not completed within the time specified for timeout.	<ul style="list-style-type: none"> The power supply to the server is OFF. The Ethernet cable connector is disconnected. The Ethernet cable is broken. The server's processing time is long. 				S		W527
54013013 hex	DB Connection Service Error Stop	The instruction could not be executed because the DB Connection Service was stopped due to an error.	<ul style="list-style-type: none"> The DB Connection settings are corrupted. 				S		W527
54013014 hex	Data Already Spooled	One or more SQL statements are already stored in the Spool memory.	<ul style="list-style-type: none"> A DB_Insert or DB_Update instruction was executed when one or more SQL statements were already stored in the Spool memory. A DB_Select or DB_Delete instruction was executed when one or more SQL statements were already stored in the Spool memory. 				S		W527
54013015 hex	DB Connection Service Initializing	The instruction could not be executed because the initialization processing of the DB Connection Service is in progress.	<ul style="list-style-type: none"> The relevant instruction was executed during the initialization processing of the DB Connection Service. 				S		W527
54013016 hex	DB in Process	The instruction could not be executed because the DB is under processing in the server.	<ul style="list-style-type: none"> Though a DB Connection Instruction Execution Timeout occurred for the previous instruction, the relevant instruction was executed before completion of the DB's processing in the server. 				S		W527
54013017 hex	Operation Log Disabled	The log could not be recorded because the specified Operation Log is disabled.	<ul style="list-style-type: none"> Though Execution Log was specified in the <i>LogType</i> input variable, the Execution Log is disabled. Though Debug Log was specified in the <i>LogType</i> input variable, recording to the Debug Log is stopped. 				S		W527

3-1-9 Errors in GEM Services

The section provides tables of the errors (events) that can occur in the GEM Services and GEM instructions.

You can use the GEM Services and GEM instructions with the NJ501-1340 CPU Unit. The unit version of the CPU Unit is 1.09 or later.

The errors are divided into the following functional groups.

- GEM Services
- GEM instructions

GEM Services

The manual names are given below for the catalog numbers given in the *Reference* column of the event table.

Cat. No.	Manual name
W528	NJ-series SECS/GEM CPU Units User's Manual

Event code	Event name	Meaning	Assumed cause	Level					Reference
				Maj	Prt	Min	Obs	Info	
14E00000 hex	Invalid GEM Setting Data	The GEM setting data is invalid.	<ul style="list-style-type: none"> • The power supply to the CPU Unit was interrupted during a transfer of the setting data of the GEM Service. • The setting data of the GEM Service is not correct because the power supply to the Controller was interrupted during a Clear All Memory operation. • Non-volatile memory failed. 			S			W528
14E20000 hex	Spool Data Discarded	The spool data is discarded.	<ul style="list-style-type: none"> • The spool data was discarded because the power supply to the CPU Unit was interrupted with no shutdown. 			S			W528
14E30000 hex	Spool Save Failed	Failed to save the spooled data to the SD Memory Card.	<ul style="list-style-type: none"> • The capacity of the SD Memory Card is insufficient. • The SD Memory Card is damaged. 			S			W528
35400000 hex	Illegal Variable Allocation	Resolution of the variable allocation failed.	<ul style="list-style-type: none"> • The variable that is specified in the SECS/GEM Configurator does not exist in the global variables. • The data type, constant attribute, number of array dimensions or number of array elements of the variable that is set in the SECS/GEM Configurator is different from the variable defined in the global variables. 			S			W528
35410000 hex	Illegal TCP Port Number	The TCP port number for the host communications is illegal.	<ul style="list-style-type: none"> • The TCP port number for the host communications is also used as the TCP port number of another function. 			S			W528
14E10000 hex	GEM Service Log Save Failed	An error occurred when the GEM Service log is written to the SD Memory Card.	<ul style="list-style-type: none"> • The capacity of the SD Memory Card is insufficient. • The SD Memory Card is damaged. 				S		W528

Event code	Event name	Meaning	Assumed cause	Level					Reference
				Maj	Prt	Min	Obs	Info	
14E40000 hex	Invalid SD Memory Card	An SD Memory Card is not inserted or an SD Memory Card that cannot be written is inserted.	<ul style="list-style-type: none"> An SD Memory Card is not inserted. The SD Memory Card type is not correct. The format of the SD Memory Card is not correct. The SD Memory Card is write protected. 				S		W528
66000000 hex	Send Transaction Queue Overrun	The send transaction exceeded the capacity for temporary storage.	<ul style="list-style-type: none"> The capacity to process the send transaction is insufficient. 				S		W528
66010000 hex	Reception Transaction Queue Overrun	The reception transaction exceeded the capacity for temporary storage.	<ul style="list-style-type: none"> The capacity to process the reception transaction is insufficient. 				S		W528
66020000 hex	Too Long SECS Message	The SECS message to be sent to the host exceeds the maximum length.	<ul style="list-style-type: none"> The SECS message to be sent to the host exceeds the maximum length. 				S		W528
95420000 hex	GEM Service Started	The GEM Service started normally.	<ul style="list-style-type: none"> The GEM Service started normally. 					S	W528
95430000 hex	Shutdown Completed	The shutdown processing was completed normally.	<ul style="list-style-type: none"> The shutdown processing was completed normally. 					S	W528
95440000 hex	GEM Setting Data Changed	The setting data of the GEM Service was changed.	<ul style="list-style-type: none"> The setting data of the GEM Service from the SECS/GEM Configurator was changed. 					S	W528
95450000 hex	Valid SD Memory Card	An SD Memory Card that can be written is inserted.	<ul style="list-style-type: none"> An SD Memory Card that can be written is inserted. 					S	W528

GEM Instructions

The lower four digits of the following event codes indicate the instruction error codes. For descriptions of an error code, refer to the description of the corresponding event code. For example, if the error code of the instruction is 16#0400, refer to the description of the event with event code 54010400 hex.

The manual names are given below for the catalog numbers given in the *Reference* column of the event table.

Cat. No.	Manual name
W502	NJ/NX-series Instructions Reference Manual
W528	NJ-series SECS/GEM CPU Units User's Manual

Event code	Event name	Meaning	Assumed cause	Level					Reference
				Maj	Prt	Min	Obs	Info	
54010400 hex	Input Value Out of Range	An input parameter for an instruction exceeded the valid range for an input variable. Or, division by an integer of 0 occurred in division or remainder calculations.	<ul style="list-style-type: none"> An input parameter for an instruction exceeded the valid range for an input variable. Or, division by an integer of 0 occurred in division or remainder calculations. 				S		W502

Event code	Event name	Meaning	Assumed cause	Level					Reference
				Maj	Prt	Min	Obs	Info	
54010419 hex	Incorrect Data Type	A data type that cannot be used for an instruction is specified for an input or in-out variable.	<ul style="list-style-type: none"> A data type that cannot be used for an instruction is specified for an input or in-out variable. 				S		W502
5401041D hex	Exceeded Simultaneous Instruction Executed Resources	The maximum resources that you can use for the relevant instruction group at the same time was exceeded.	<ul style="list-style-type: none"> More than the maximum number of relevant instructions were executed at the same time. 				S		W502
54013810 hex	GEM Service Status in Initializing	An instruction was executed when the GEM Service status was Initializing.	<ul style="list-style-type: none"> The relevant instruction was executed when the GEM Service status was Initializing. 				S		W528
54013811 hex	GEM Service Status in EQStarting	An instruction was executed when the GEM Service status was EQStarting.	<ul style="list-style-type: none"> The relevant instruction was executed when the GEM Service status was EQStarting. 				S		W528
54013812 hex	GEM Service Status in EQInitializing	An instruction was executed when the GEM Service status was EQInitializing.	<ul style="list-style-type: none"> The relevant instruction was executed when the GEM Service status was EQInitializing. 				S		W528
54013813 hex	GEM Service Status in EQRun	An instruction was executed when the GEM Service status was EQRun.	<ul style="list-style-type: none"> The relevant instruction was executed when the GEM Service status was EQRun. 				S		W528
54013814 hex	GEM Service Status in Stop	An instruction was executed when the GEM Service status was Stop.	<ul style="list-style-type: none"> The relevant instruction was executed when the GEM Service status was Stop. 				S		W528
54013815 hex	GEM Service Status in Error	An instruction was executed when the GEM Service status was Error.	<ul style="list-style-type: none"> The relevant instruction was executed when the GEM Service status was Error. 				S		W528
54013816 hex	GEM Service Status in ShuttingDown	An instruction was executed when the GEM Service status was ShuttingDown.	<ul style="list-style-type: none"> The relevant instruction was executed when the GEM Service status was ShuttingDown. 				S		W528
54013817 hex	GEM Service Status in Shutdown	An instruction was executed when the GEM Service status was Shutdown.	<ul style="list-style-type: none"> The relevant instruction was executed when the GEM Service status was Shutdown. 				S		W528
54013818 hex	No Message Received	An instruction was executed without receiving a SECS message from the host.	<ul style="list-style-type: none"> The relevant instruction was executed without receiving the relevant SECS message from the host. 				S		W528
54013819 hex	Multi-execution of Instructions	Processing of a transaction for a different instance of the same instruction that was executed before this instruction is not completed.	<ul style="list-style-type: none"> This instruction was executed before completing processing for a transaction for a different instance of the same instruction. 				S		W528
5401381A hex	State Transition in Progress	A state transition for a different instance of the same instruction that was executed before this instruction is not completed.	<ul style="list-style-type: none"> This instruction was executed for a different instance of the GEM_ChangeCommState instruction in EnabledNotComm state. This instruction was executed for a different instance of the GEM_ChangeControlState instruction in AttemptOnline state. 				S		W528

Event code	Event name	Meaning	Assumed cause	Level					Reference
				Maj	Prt	Min	Obs	Info	
5401381B hex	Insufficient Transaction Resource	The instruction was executed while the number of transactions that can be buffered exceeds the upper limit.	<ul style="list-style-type: none"> The instruction was executed while the number of transactions that can be buffered exceeds the upper limit. 				S		W528
54013820 hex	Too Many Characters	More characters were specified than the number that was set and the instruction was executed.	<ul style="list-style-type: none"> More characters were specified than the number of characters set with the SECS/GEM Configurator. 				S		W528
54013821 hex	Invalid Size	An incorrect array or an array with an incorrect number of elements was specified and the instruction was executed.	<ul style="list-style-type: none"> A value was specified that is larger than the maximum table size set with the SECS/GEM Configurator. 				S		W528
54013822 hex	Set to Disable	The instruction that was set to disable was executed.	<ul style="list-style-type: none"> The instruction executed for a GEM capability was disabled on the SECS/GEM Configurator. 				S		W528
54013824 hex	Undefined CEID	An undefined CEID was specified and the instruction was executed.	<ul style="list-style-type: none"> A CEID that was not defined in the SECS/GEM Configurator was specified. 				S		W528
54013825 hex	Undefined ALID	An undefined ALID was specified and the instruction was executed.	<ul style="list-style-type: none"> An ALID that was not defined in the SECS/GEM Configurator was specified. 				S		W528
54013826 hex	Undefined CCODE	An undefined CCODE was specified and the instruction was executed.	<ul style="list-style-type: none"> A CCODE that was not defined in the SECS/GEM Configurator was specified. 				S		W528
54013827 hex	Undefined Message Number	An undefined message number was specified and the instruction was executed.	<ul style="list-style-type: none"> A message number that was not defined in the SECS/GEM Configurator was specified. 				S		W528
54013828 hex	HSMS Communications Setting Out of Range	An HSMS communications setting that is out of range was specified and the instruction was executed.	<ul style="list-style-type: none"> An HSMS communications setting that is out of range was specified. 				S		W528
54013829 hex	TID Out of Range	A TID that is out of range was specified and the instruction was executed.	<ul style="list-style-type: none"> A TID that is out of range was specified. 				S		W528
5401382C hex	Undefined ECID	An undefined ECID was specified and the instruction was executed.	<ul style="list-style-type: none"> An ECID that was not defined in the SECS/GEM Configurator was specified. 				S		W528
5401382D hex	Type Mismatch	A value with an incorrect data type was specified and the instruction was executed.	<ul style="list-style-type: none"> A different equipment constant data type than the one registered with the SECS/GEM Configurator was specified. 				S		W528
5401382E hex	ECV Out of Range	An out-of-range value was specified for an equipment constant and the instruction was executed.	<ul style="list-style-type: none"> A value was specified that is outside the upper and lower limits of the value of the equipment constant that was set on the SECS/GEM Configurator. 				S		W528

Event code	Event name	Meaning	Assumed cause	Level					Reference
				Maj	Prt	Min	Obs	Info	
5401382F hex	Illegal CPNAME	A CPNAME that is different from the received CPNAME was specified and the instruction was executed.	• A CPNAME was specified that is different from the received CPNAME.				S		W528
54013830 hex	HACK Out of Range	An HACK that is out of range was specified and the instruction was executed.	• An HACK that is out of range was specified.				S		W528
54013831 hex	CPACK Out of Range	A CPACK that is out of range was specified and the instruction was executed.	• A CPACK that is out of range was specified.				S		W528
54013832 hex	CEPACK Out of Range	A CEPACK that is out of range was specified and the instruction was executed.	• A CEPACK that is out of range was specified.				S		W528
54013833 hex	ACKC7 Out of Range	An ACKC7 that is out of range was specified and the instruction was executed.	• An ACKC7 that is out of range was specified.				S		W528
54013834 hex	ACKC7A Out of Range	An ACKC7A that is out of range was specified and the instruction was executed.	• An ACKC7A that is out of range was specified.				S		W528
54013835 hex	ACKC10 Out of Range	An ACKC10 that is out of range was specified and the instruction was executed.	• An ACKC10 that is out of range was specified.				S		W528
54013836 hex	EAC Out of Range	An EAC that is out of range was specified and the instruction was executed.	• An EAC that is out of range was specified.				S		W528
54013838 hex	Illegal SECS Message	A message number for which an illegal SECS message is set was specified and the instruction was executed.	• A message number for which a SECS message that does not agree with the instruction specifications was specified.				S		W528

3-1-10 Errors in Robot Control Function

The section provides tables of the errors (events) that can occur in the robot control functions and robot instructions.

You can use the robot control functions and robot instructions with the NJ501-4□□□ CPU Unit. The unit version of the CPU Unit is 1.09 or later.

General Robot Control

The upper four digits of the event code give the error code for the instruction. For descriptions of an error code, refer to the description of the corresponding event code. For example, if the error code of the instruction is 16#5422, refer to the description of the event with event code 54220000 hex.

The manual names are given below for the catalog numbers given in the *Reference* column of the event table.

Cat. No.	Manual name
W539	NJ-series NJ Robotics CPU Unit User's Manual

Event code	Event name	Meaning	Assumed cause	Level					Reference
				Maj	Prt	Min	Obs	Info	
54220000 hex	Target Velocity Setting Out of Range	The parameter specified for the <i>Velocity</i> input variable to a motion control instruction is out of range.	<ul style="list-style-type: none"> Instruction input parameter exceeded the valid range of the input variable. 			S			W539
54230000 hex	Acceleration Setting Out of Range	The parameter specified for the <i>Acceleration</i> input variable to a motion control instruction is out of range.	<ul style="list-style-type: none"> Instruction input parameter exceeded the valid range of the input variable. 			S			W539
54240000 hex	Deceleration Setting Out of Range	The parameter specified for the <i>Deceleration</i> input variable to a motion control instruction is out of range.	<ul style="list-style-type: none"> Instruction input parameter exceeded the valid range of the input variable. 			S			W539
542B0000 hex	Buffer Mode Selection Out of Range	The parameter specified for the <i>BufferMode</i> input variable to a motion control instruction is out of range.	<ul style="list-style-type: none"> Instruction input parameter exceeded the valid range of the input variable. 			S			W539
542C0000 hex	Coordinate System Selection Out of Range	The parameter specified for the <i>CoordSystem</i> input variable to a motion control instruction is out of range.	<ul style="list-style-type: none"> Instruction input parameter exceeded the valid range of the input variable. 			S			W539
542E0000 hex	Direction Selection Out of Range	The parameter specified for the <i>Direction</i> input variable to a motion control instruction is out of range.	<ul style="list-style-type: none"> Instruction input parameter exceeded the valid range of the input variable. 			S			W539
54320000 hex	Transition Mode Selection Out of Range	The parameter specified for the <i>TransitionMode</i> input variable to a motion control instruction is out of range.	<ul style="list-style-type: none"> Instruction input parameter exceeded the valid range of the input variable. <i>_mcAborting</i> or <i>_mcBuffered</i> was specified for <i>BufferMode</i> and <i>_mcTMNone</i> was not specified for <i>TransitionMode</i>. 			S			W539

Event code	Event name	Meaning	Assumed cause	Level					Reference
				Maj	Prt	Min	Obs	Info	
543B0000 hex	Motion Control Instruction Re-execution Disabled	An attempt was made to re-execute a motion control instruction that cannot be re-executed.	<ul style="list-style-type: none"> A motion control instruction that cannot be re-executed was re-executed. 			S			W539
543C0000 hex	Motion Control Instruction Multi-execution Disabled	Multiple functions that cannot be executed simultaneously were executed for the same target (MC common, axis, or axes group).	<ul style="list-style-type: none"> Multiple functions that cannot be executed simultaneously were executed for the same target (MC common, axis, or axes group). 			S			W539
543E0000 hex	Instruction Cannot Be Executed during Multi-axes Coordinated Control	<ul style="list-style-type: none"> A motion instruction was executed for an axis or an axes group that was in a coordinated multi-axes motion. A robot instruction that you cannot use for an axes group in a <i>GroupEnable</i> state was executed. 	<ul style="list-style-type: none"> A motion instruction was executed for an axis or an axes group that was in a coordinated multi-axes motion. The MC_SetKinTransform instruction was executed for an axes group in a <i>GroupEnable</i> state. 			S			W539
543F0000 hex	Multi-axes Coordinated Control Instruction Executed for Disabled Axes Group	A multi-axes coordinated control instruction was executed for an axes group that was in a <i>GroupDisable</i> state.	<ul style="list-style-type: none"> A multi-axes coordinated control instruction was executed for an axes group that was in a <i>GroupDisable</i> state. One of the following instructions was executed for an axes group that was in a <i>GroupDisable</i> state. MC_MoveTimeAbsolute MC_SyncLinearConveyor MC_SyncOut MC_RobotJog 			S			W539
54410000 hex	Impossible Axis Operation Specified when the Servo is OFF	A motion instruction was executed for an axis for which the Servo is OFF.	<ul style="list-style-type: none"> A motion instruction was executed for an axis for which the Servo is OFF. A zero position preset was performed with the MC_Home or MC_HomeWithParameter instruction for an axis for which EtherCAT process data communications are not established. 			S			W539
54420000 hex	Composition Axis Stopped Error	A motion instruction was executed for an axes group while the MC_Stop instruction was being executed for a composition axis.	<ul style="list-style-type: none"> A motion instruction was executed for an axes group while the MC_Stop instruction was being executed for a composition axis. 			S			W539
54430000 hex	Motion Control Instruction Multi-execution Buffer Limit Exceeded	The number of motion control instructions that is buffered for Buffered or Blending Buffer Modes exceeded the buffer limit.	<ul style="list-style-type: none"> An axis instruction was executed when there was already a current instruction and a buffered instruction for the same axis. An axes group instruction was executed when there was already eight current instructions and buffered instructions for the same axis. 			S			W539

Event code	Event name	Meaning	Assumed cause	Level					Reference
				Maj	Prt	Min	Obs	Info	
54570000 hex	Motion Control Instruction Re-execution Disabled (Axes Group Specification)	An attempt was made to change the parameter for the <i>AxesGroup</i> input variable when re-executing a motion control instruction. (This input variable cannot be changed when re-executing an instruction.)	<ul style="list-style-type: none"> A parameter for an input variable that cannot be changed for re-execution was changed. 			S			W539
54610000 hex	Illegal Axes Group Specification	The axes group specified for the <i>AxesGroup</i> input variable to a motion control instruction does not exist or is not a used axes group.	<ul style="list-style-type: none"> An axes group does not exist for the variable specified for the <i>AxesGroup</i> input variable to the instruction. The axes group specified for the <i>AxesGroup</i> input variable to the instruction is not specified as a used axes group. 			S			W539
54660000 hex	Instruction Execution Error with Undefined Home	High-speed homing, an interpolation instruction, or a robot instruction was executed when home was undefined.	<ul style="list-style-type: none"> High-speed homing was executed when home was undefined. An interpolation instruction was executed for an axes group that includes an axis with no defined home. One of the following robot instructions was executed for an axes group that includes a logical axis with no defined home. MC_SetKinTransform MC_MoveTimeAbsolute MC_SyncLinearConveyor MC_SyncOut MC_GroupMon MC_RobotJog 			S			W539
54780000 hex	Target Position Setting Out of Range	The parameter specified for the <i>Position</i> input variable to a motion control instruction is out of range.	<ul style="list-style-type: none"> Instruction input parameter exceeded the valid range of the input variable. The target position of a Rotary Mode axis is not within the ring setting range. 			S			W539
57050000 hex	Kinematics Unsupported Instruction	An attempt was made to execute an instruction that cannot be used for an axes group for which the kinematics transform was set.	<ul style="list-style-type: none"> One of the following instructions was executed for an axes group for which the kinematics transform was set. MC_MoveLinear MC_MoveLinearAbsolute MC_MoveLinearRelative MC_MoveCircular2D MC_ChangeAxesInGroup 			S			W539

Event code	Event name	Meaning	Assumed cause	Level					Reference
				Maj	Prt	Min	Obs	Info	
57060000 hex	Axes Group Mismatch with Kinematics	The configuration elements of the specified axes group and the specified kinematics do not match.	<ul style="list-style-type: none"> The number of axes in the axes group and the number of axes in the specified robot (kinematics type) do not match. The count mode for axes in the axes group and the count mode for the specified robot (kinematics type) do not match. The display unit for axes in the axes group and the display unit for the specified robot (kinematics type) do not match. 			S			W539
57070000 hex	Kinematics Type Out of Range	<i>KinType</i> specified for the <i>KinTransform</i> input variable to a motion control instruction is out of range.	<ul style="list-style-type: none"> <i>KinType</i> is outside the setting range. 			S			W539
57080000 hex	Kinematics Parameter Out of Range	<i>KinParam</i> or <i>ExpansionParam</i> specified for the <i>KinTransform</i> input variable to a motion control instruction is out of range.	<ul style="list-style-type: none"> <i>KinParam</i> is outside the setting range. <i>ExpansionParam</i> is outside the setting range. 			S			W539
57090000 hex	Workspace Type Out of Range	<i>WorkspaceType</i> specified for the <i>Workspace</i> input variable to a motion control instruction is out of range.	<ul style="list-style-type: none"> <i>WorkspaceType</i> is outside the setting range. 			S			W539
570A0000 hex	Workspace Parameter Out of Range	<i>WorkspaceParam</i> specified for the <i>Workspace</i> input variable to a motion control instruction is out of range.	<ul style="list-style-type: none"> <i>WorkspaceParam</i> is outside the setting range. 			S			W539
570B0000 hex	Invalid Coordinate System Number	The coordinate system ID specified for the <i>CSID</i> input variable to a motion control instruction is out of range or not defined.	<ul style="list-style-type: none"> The coordinate system ID is outside the setting range. The specified coordinate system ID is not defined by the <i>MC_DefineCoordSystem</i> instruction. 			S			W539
570C0000 hex	Coordinate Transformation Parameter Out of Range	The coordinate transformation parameter <i>Pose</i> , which was specified for the <i>CoordTransform</i> input variable to a motion control instruction, is out of range.	<ul style="list-style-type: none"> The coordinate transformation parameter <i>Pose</i> is outside the setting range. 			S			W539
570D0000 hex	Transition parameters out of range	The Transition Parameters specified for the <i>TransitionParameter</i> input variable to a motion control instruction is out of range.	<ul style="list-style-type: none"> <i>TransitionParameter</i> is outside the setting range. 			S			W539

Event code	Event name	Meaning	Assumed cause	Level					Reference
				Maj	Prt	Min	Obs	Info	
570F0000 hex	Cannot Calculate Kinematics	The inverse kinematics or direct kinematics cannot be calculated.	<ul style="list-style-type: none"> The kinematics parameter is outside the setting range. One of the robot axes (A0 to A2) is stopped at the position for which direct kinematics calculation cannot be performed. Inverse kinematics calculation cannot be performed for the target position specified in the machine coordinate system. 			S			W539
57100000 hex	Kinematics Transform Not Set	The kinematics transform is not set for the specified axes group.	<ul style="list-style-type: none"> The kinematics transform is not set for the axes group. 			S			W539
57110000 hex	Target Position Out of Range	The position parameter specified as variable for the Position is out of range.	<ul style="list-style-type: none"> Specified wrong value of Position input. 			S			W539
57120000 hex	Velocity Error Detection Value Out of Range	<i>MaxVelocity</i> specified for the <i>TrajData</i> input variable to a motion control instruction is out of range.	<ul style="list-style-type: none"> <i>MaxVelocity</i> is outside the setting range. 			S			W539
57130000 hex	Acceleration Error Detection Value Out of Range	<i>MaxAcceleration</i> specified for the <i>TrajData</i> input variable to a motion control instruction is out of range.	<ul style="list-style-type: none"> <i>MaxAcceleration</i> is outside the setting range. 			S			W539
57140000 hex	Trajectory Target Time Out of Range	<i>TrajTime</i> specified for the <i>TrajData</i> input variable to a motion control instruction is out of range.	<ul style="list-style-type: none"> <i>TrajTime</i> is outside the setting range. 			S			W539
57150000 hex	Trajectory Type Out of Range	<i>MoveTrajType</i> specified for the <i>TrajData</i> input variable to a motion control instruction is out of range.	<ul style="list-style-type: none"> <i>MoveTrajType</i> or <i>SyncTrajType</i> is outside the setting range. 			S			W539
57160000 hex	Trajectory Transition Out of Range	<i>TrajTransition</i> specified for the <i>TrajData</i> input variable to a motion control instruction is out of range.	<ul style="list-style-type: none"> <i>TrajTransition</i> is outside the setting range. 			S			W539
57170000 hex	Trajectory Travel Distance Out of Range	<i>TrajDistance</i> specified for the <i>TrajData</i> input variable to a motion control instruction is out of range.	<ul style="list-style-type: none"> <i>TrajDistance</i> is outside the setting range. 			S			W539
57190000 hex	Initial Workpiece Position Outside Workspace	The position of the workpiece specified for the <i>InitWorkpiecePosition</i> input variable to a motion control instruction is outside the workspace.	<ul style="list-style-type: none"> <i>InitWorkpiecePosition</i> is outside the workspace. 			S			W539

Event code	Event name	Meaning	Assumed cause	Level					Reference
				Maj	Prt	Min	Obs	Info	
571A0000 hex	Invalid Conveyor Axis Specified	The axis specified for the <i>ConveyorAxis</i> input variable to a motion control instruction is not correct.	<ul style="list-style-type: none"> The specified axis is registered in the axes group which is specified for <i>AxesGroup</i>. The specified axis is an unused axis. The unit of the conveyor axis is incorrect. 			S			W539
571B0000 hex	Target Position Outside Workspace	The target position specified for the <i>Position</i> input variable to a motion control instruction is outside the workspace.	<ul style="list-style-type: none"> <i>Position</i> is outside the workspace. 			S			W539
571C0000 hex	Cannot Cancel Synchronization	The MC_SyncOut instruction cannot be executed.	<ul style="list-style-type: none"> The MC_SyncLinear-Conveyor instruction was not executed. The MC_SyncLinear-Conveyor instruction execution is in progress, but synchronization is not currently performed. 			S			W539
571E0000 hex	Too Many Kinematics	The number of kinematics exceeded the limit.	<ul style="list-style-type: none"> The number kinematics set by the MC_SetKin-Transform instruction exceeded the limit. 			S			W539
571F0000 hex	Kinematics Initialization Error	Kinematics initialization failed.	<ul style="list-style-type: none"> One of the robot axes (A0 to A3) is stopped at the position for which direct kinematics calculation cannot be performed. 			S			W539
57320000 hex	Invalid Tool Number	The tool ID specified for the <i>ToolID</i> input variable to a motion control instruction is out of range or not defined.	<ul style="list-style-type: none"> <i>ToolID</i> is outside the setting range. The specified tool ID is not defined by the MC_DefineToolTransform instruction. 			S			W539
57330000 hex	Tool Parameter Out of Range	The transform parameter specified for the <i>ToolTransform</i> input variable to a motion control instruction is out of range.	<ul style="list-style-type: none"> The transform parameter is outside the setting range. 			S			W539
57340000 hex	Unsupported Transition Data	The transition mode specified for the <i>TransitionMode</i> input variable to a motion control instruction does not support the current instruction or the buffered instruction.	<ul style="list-style-type: none"> The parameters specified for the <i>TransitionParameter</i> input variable cannot be used for transition in the mode specified for the <i>TransitionMode</i> input variable. The trajectory data which is set for the buffered instruction cannot be used for transition in the mode specified for the <i>TransitionMode</i> input variable. 			S			W539
57360000 hex	Offset Not Allowed	During the MC_SyncLinearConveyor instruction execution, the offset function can be used only in Phase6.	<ul style="list-style-type: none"> The <i>EnableOffset</i> input variable changed to TRUE before the MC_SyncLinearConveyor instruction operation entered Phase6. 			S			W539

Event code	Event name	Meaning	Assumed cause	Level					Reference
				Maj	Prt	Min	Obs	Info	
57370000 hex	Motion Control Instruction Multi-execution Disabled (Trajectory Type)	An input variable that cannot be changed was changed during multi-execution of instructions.	<ul style="list-style-type: none"> • <i>MoveTrajType</i> or <i>SyncTrajType</i> for the current instruction do not match <i>MoveTrajType</i> or <i>SyncTrajType</i> for the next instruction executed with <i>Buffered</i> or <i>Blending</i>. 			S			W539
57390000 hex	Unsupported Transition Mode	The next instruction was executed with <i>TransitionMode</i> which does not support the combination of the current and next instructions.	<ul style="list-style-type: none"> • The transition mode specified for the <i>TransitionMode</i> input variable to a motion control instruction does not support the combination of the current instruction and buffered instruction. 			S			W539
57440000 hex	Jog Mode Out of Range	The <i>JogMode</i> input variable to the MC_RobotJog instruction is out of range.	<ul style="list-style-type: none"> • The <i>JogMode</i> input variable to the MC_RobotJog instruction is outside the setting range. 			S			W539
57450000 hex	Initial Workpiece Position Out of Range	The <i>InitWorkpiecePosition</i> input variable to the MC_SyncLinearConveyor instruction is out of range.	<ul style="list-style-type: none"> • The <i>InitWorkpiecePosition</i> input variable to the MC_SyncLinearConveyor instruction is outside the setting range. 			S			W539
57460000 hex	Maximum Interpolation Velocity Out of Range	The <i>MaxVelocityTCP</i> input variable to the MC_SetKinTransform instruction is out of range.	<ul style="list-style-type: none"> • The <i>MaxVelocityTCP</i> input variable to the MC_SetKinTransform instruction is outside the setting range. 			S			W539
57470000 hex	Maximum Interpolation Acceleration Out of Range	The <i>MaxAccelerationTCP</i> input variable to the MC_SetKinTransform instruction is out of range.	<ul style="list-style-type: none"> • The <i>MaxAccelerationTCP</i> input variable to the MC_SetKinTransform instruction is outside the setting range. 			S			W539
57480000 hex	Maximum Interpolation Deceleration Out of Range	The <i>MaxDecelerationTCP</i> input variable to the MC_SetKinTransform instruction is out of range.	<ul style="list-style-type: none"> • The <i>MaxDecelerationTCP</i> input variable to the MC_SetKinTransform instruction is outside the setting range. 			S			W539
64430000 hex	Positive Limit Input	An instruction was executed for a motion in the positive direction when the positive limit input was ON.	<ul style="list-style-type: none"> • An instruction for a motion in the positive direction was executed when the positive limit input was ON, or an instruction for a motion with no direction specification was executed when the positive limit input was ON. An axes group motion control instruction was executed when the positive limit input was ON. 			S			W539
64440000 hex	Negative Limit Input	An instruction for a motion in the negative direction was executed when the negative limit input was ON.	<ul style="list-style-type: none"> • An instruction for a motion in the negative direction was executed when the negative limit input was ON, or an instruction for a motion with no direction specification was executed when the negative limit input was ON. An axes group motion control instruction was executed when the negative limit input was ON. 			S			W539

Event code	Event name	Meaning	Assumed cause	Level					Reference
				Maj	Prt	Min	Obs	Info	
64590000 hex	Home Undefined during Coordinated Motion	Home of the logical axis became undefined during axes group motion or while decelerating to a stop.	<ul style="list-style-type: none"> The command position or actual position overflowed or underflowed for a logical axis in an axes group motion or a logical axis that was decelerating to a stop and the home definition was lost. A slave communications error occurred for a logical axis and home became undefined during axes group motion or while decelerating to a stop. A slave for a logical axis left the network or was disabled and home became undefined during axes group motion or while decelerating to a stop. 			S			W539
645A0000 hex	Maximum Interpolation Velocity Error	The command velocity exceeded the maximum interpolation velocity specified for the <i>MaxVelocityTCP</i> input variable to the MC_SetKinTransform instruction.	<ul style="list-style-type: none"> The trajectory data for the current instruction is incorrect. The maximum interpolation velocity specified for the <i>MaxVelocityTCP</i> input variable to the MC_SetKinTransform instruction is incorrect or too low. 			S			W539
645B0000 hex	Maximum Interpolation Acceleration Error	The command acceleration rate exceeded the maximum interpolation acceleration specified for the <i>MaxAccelerationTCP</i> input variable to the MC_SetKinTransform instruction.	<ul style="list-style-type: none"> The trajectory data for the current instruction is incorrect. The maximum interpolation acceleration specified for the <i>MaxAccelerationTCP</i> input variable to the MC_SetKinTransform instruction is incorrect or too low. 			S			W539
645C0000 hex	Maximum Interpolation Deceleration Error	The command deceleration rate exceeded the maximum interpolation deceleration specified for the <i>MaxDecelerationTCP</i> input variable to the MC_SetKinTransform instruction.	<ul style="list-style-type: none"> The trajectory data for the current instruction is incorrect. The maximum interpolation deceleration specified for the <i>MaxDecelerationTCP</i> input variable to the MC_SetKinTransform instruction is incorrect or too low. 			S			W539
67000000 hex	Command Position Outside Workspace	The command position is outside the workspace.	<ul style="list-style-type: none"> The specified trajectory data is incorrect. 			S			W539

Event code	Event name	Meaning	Assumed cause	Level					Reference
				Maj	Prt	Min	Obs	Info	
67010000 hex	Current Position Outside Workspace	The current position was outside the workspace when an instruction was executed.	<ul style="list-style-type: none"> The current position was outside the workspace when one of the following instructions was executed. MC_MoveTimeAbsolute MC_SyncLinearConveyor MC_SyncOut MC_RobotJog 			S			W539
67020000 hex	Workpiece Synchronization Excessive Following Error	The robot could not catch up the workpiece on the conveyor.	<ul style="list-style-type: none"> The conveyor position was changed before the robot reached the workpiece. The conveyor current position is incorrect. 			S			W539
67030000 hex	Velocity Error Detection	The command velocity exceeded <i>MaxVelocity</i> specified for the <i>TrajData</i> input variable to a motion control instruction.	<ul style="list-style-type: none"> The combination of parameters specified for the <i>TrajData</i> input variable caused a too high command velocity. The parameters specified for the <i>TrajData</i> input variable are incorrect. <i>MaxVelocity</i> is too low. 			S			W539
67040000 hex	Acceleration Error Detection	The command acceleration rate exceeded the <i>MaxAcceleration</i> specified for the <i>TrajData</i> input variable to a motion control instruction.	<ul style="list-style-type: none"> The combination of parameters specified for the <i>TrajData</i> input variable caused a too high command acceleration rate. The parameters specified for the <i>TrajData</i> input variable are incorrect. <i>MaxAcceleration</i> is too low. 			S			W539
67050000 hex	Command Current Velocity Limit Exceeded	The command current velocity exceeded the axis maximum velocity.	<ul style="list-style-type: none"> The axis maximum velocity was exceeded. 			S			W539
74300000 hex	Axes Group Composition Axis Error	An error occurred for an axis in an axes group.	<ul style="list-style-type: none"> An error occurred for an axis in an axes group that was in motion. 			S			W539
77000000 hex	Conveyor Axis Position Read Error	The MC_SyncLinearConveyor instruction cannot be executed due to a conveyor axis position error.	<ul style="list-style-type: none"> EtherCAT process data communications are not established for the conveyor axis. The slave of the conveyor axis was disconnected. An Absolute Encoder Current Position Calculation Failed error (64580000 hex) was detected for the conveyor axis. 			S			W539
94230000 hex	Transition Parameter Adjusted	The specified <i>TransitionParameter</i> input variable was adjusted before transition started.	<ul style="list-style-type: none"> The transition start condition specified for <i>TransitionParameter</i> input variable for multi-execution of instructions was already exceeded by the current instruction. 				S		W539

Robot Instructions

The manual names are given below for the catalog numbers given in the *Reference* column of the event table.

Cat. No.	Manual name
W539	NJ-series NJ Robotics CPU Unit User's Manual

Event code	Event name	Meaning	Assumed cause	Level					Reference
				Maj	Prt	Min	Obs	Info	
54015422 hex	Target Velocity Setting Out of Range	The parameter specified for the <i>Velocity</i> input variable to a motion control instruction is out of range.	<ul style="list-style-type: none"> Instruction input parameter exceeded the valid range of the input variable. 				S		W539
54015423 hex	Acceleration Setting Out of Range	The parameter specified for the <i>Acceleration</i> input variable to a motion control instruction is out of range.	<ul style="list-style-type: none"> Instruction input parameter exceeded the valid range of the input variable. 				S		W539
54015424 hex	Deceleration Setting Out of Range	The parameter specified for the <i>Deceleration</i> input variable to a motion control instruction is out of range.	<ul style="list-style-type: none"> Instruction input parameter exceeded the valid range of the input variable. 				S		W539
5401542B hex	Buffer Mode Selection Out of Range	The parameter specified for the <i>BufferMode</i> input variable to a motion control instruction is out of range.	<ul style="list-style-type: none"> Instruction input parameter exceeded the valid range of the input variable. 				S		W539
5401542C hex	Coordinate System Selection Out of Range	The parameter specified for the <i>CoordSystem</i> input variable to a motion control instruction is out of range.	<ul style="list-style-type: none"> Instruction input parameter exceeded the valid range of the input variable. 				S		W539
5401542E hex	Direction Selection Out of Range	The parameter specified for the <i>Direction</i> input variable to a motion control instruction is out of range.	<ul style="list-style-type: none"> Instruction input parameter exceeded the valid range of the input variable. 				S		W539
54015432 hex	Transition Mode Selection Out of Range	The parameter specified for the <i>TransitionMode</i> input variable to a motion control instruction is out of range.	<ul style="list-style-type: none"> Instruction input parameter exceeded the valid range of the input variable. <i>_mcAborting</i> or <i>_mcBuffered</i> was specified for <i>BufferMode</i> and <i>_mcTMNone</i> was not specified for <i>TransitionMode</i>. 				S		W539
5401543B hex	Motion Control Instruction Re-execution Disabled	An attempt was made to re-execute a motion control instruction that cannot be re-executed.	<ul style="list-style-type: none"> A motion control instruction that cannot be re-executed was re-executed. 				S		W539
5401543C hex	Motion Control Instruction Multi-execution Disabled	Multiple functions that cannot be executed simultaneously were executed for the same target (MC common, axis, or axes group).	<ul style="list-style-type: none"> Multiple functions that cannot be executed simultaneously were executed for the same target (MC common, axis, or axes group). 				S		W539

Event code	Event name	Meaning	Assumed cause	Level					Reference
				Maj	Prt	Min	Obs	Info	
5401543E hex	Instruction Cannot Be Executed during Multi-axes Coordinated Control	<ul style="list-style-type: none"> A motion instruction was executed for an axis or an axes group that was in a coordinated multi-axes motion. A robot instruction that you cannot use for an axes group in a <i>GroupEnable</i> state was executed. 	<ul style="list-style-type: none"> A motion instruction was executed for an axis or an axes group that was in a coordinated multi-axes motion. The MC_SetKinTransform instruction was executed for an axes group in a <i>GroupEnable</i> state. 				S		W539
5401543F hex	Multi-axes Coordinated Control Instruction Executed for Disabled Axes Group	A multi-axes coordinated control instruction was executed for an axes group that was in a <i>GroupDisable</i> state.	<ul style="list-style-type: none"> A multi-axes coordinated control instruction was executed for an axes group that was in a <i>GroupDisable</i> state. One of the following instructions was executed for an axes group that was in a <i>GroupDisable</i> state. MC_MoveTimeAbsolute MC_SyncLinearConveyor MC_SyncOut MC_RobotJog 				S		W539
54015441 hex	Impossible Axis Operation Specified when the Servo is OFF	A motion instruction was executed for an axis for which the Servo is OFF.	<ul style="list-style-type: none"> A motion instruction was executed for an axis for which the Servo is OFF. A zero position preset was performed with the MC_Home or MC_HomeWithParameter instruction for an axis for which EtherCAT process data communications are not established. 				S		W539
54015442 hex	Composition Axis Stopped Error	A motion instruction was executed for an axes group while the MC_Stop instruction was being executed for a composition axis.	<ul style="list-style-type: none"> A motion instruction was executed for an axes group while the MC_Stop instruction was being executed for a composition axis. 				S		W539
54015443 hex	Motion Control Instruction Multi-execution Buffer Limit Exceeded	The number of motion control instructions that is buffered for Buffered or Blending Buffer Modes exceeded the buffer limit.	<ul style="list-style-type: none"> An axis instruction was executed when there was already a current instruction and a buffered instruction for the same axis. An axes group instruction was executed when there was already eight current instructions and buffered instructions for the same axis. 				S		W539
54015461 hex	Illegal Axes Group Specification	The axes group specified for the <i>AxesGroup</i> input variable to a motion control instruction does not exist or is not a used axes group.	<ul style="list-style-type: none"> An axes group does not exist for the variable specified for the <i>AxesGroup</i> input variable to the instruction. The axes group specified for the <i>AxesGroup</i> input variable to the instruction is not specified as a used axes group. 				S		W539

Event code	Event name	Meaning	Assumed cause	Level					Reference
				Maj	Prt	Min	Obs	Info	
54015466 hex	Instruction Execution Error with Undefined Home	High-speed homing, an interpolation instruction, or a robot instruction was executed when home was undefined.	<ul style="list-style-type: none"> High-speed homing was executed when home was undefined. An interpolation instruction was executed for an axes group that includes an axis with no defined home. One of the following robot instructions was executed for an axes group that includes a logical axis with no defined home. MC_SetKinTransform MC_MoveTimeAbsolute MC_SyncLinearConveyor MC_SyncOut MC_GroupMon MC_RobotJog 				S		W539
54015478 hex	Target Position Setting Out of Range	The parameter specified for the <i>Position</i> input variable to a motion control instruction is out of range.	<ul style="list-style-type: none"> Instruction input parameter exceeded the valid range of the input variable. The target position of a Rotary Mode axis is not within the ring setting range. 				S		W539
54015706 hex	Axes Group Mismatch with Kinematics	The configuration elements of the specified axes group and the specified kinematics do not match.	<ul style="list-style-type: none"> The number of axes in the axes group and the number of axes in the specified robot (kinematics type) do not match. The count mode for axes in the axes group and the count mode for the specified robot (kinematics type) do not match. The display unit for axes in the axes group and the display unit for the specified robot (kinematics type) do not match. 				S		W539
54015707 hex	Kinematics Type Out of Range	<i>KinType</i> specified for the <i>KinTransform</i> input variable to a motion control instruction is out of range.	<ul style="list-style-type: none"> <i>KinType</i> is outside the setting range. 				S		W539
54015708 hex	Kinematics Parameter Out of Range	<i>KinParam</i> or <i>ExpansionParam</i> specified for the <i>KinTransform</i> input variable to a motion control instruction is out of range.	<ul style="list-style-type: none"> <i>KinParam</i> is outside the setting range. <i>ExpansionParam</i> is outside the setting range. 				S		W539
54015709 hex	Workspace Type Out of Range	<i>WorkspaceType</i> specified for the <i>Workspace</i> input variable to a motion control instruction is out of range.	<ul style="list-style-type: none"> <i>WorkspaceType</i> is outside the setting range. 				S		W539
5401570A hex	Workspace Parameter Out of Range	<i>WorkspaceParam</i> specified for the <i>Workspace</i> input variable to a motion control instruction is out of range.	<ul style="list-style-type: none"> <i>WorkspaceParam</i> is outside the setting range. 				S		W539

Event code	Event name	Meaning	Assumed cause	Level					Reference
				Maj	Prt	Min	Obs	Info	
5401570B hex	Invalid Coordinate System Number	The coordinate system ID specified for the <i>CSID</i> input variable to a motion control instruction is out of range or not defined.	<ul style="list-style-type: none"> The coordinate system ID is outside the setting range. The specified coordinate system ID is not defined by the <i>MC_DefineCo-ordSystem</i> instruction. 				S		W539
5401570C hex	Coordinate Transformation Parameter Out of Range	The coordinate transformation parameter <i>Pose</i> , which was specified for the <i>CoordTransform</i> input variable to a motion control instruction, is out of range.	<ul style="list-style-type: none"> The coordinate transformation parameter <i>Pose</i> is outside the setting range. 				S		W539
5401570D hex	Transition parameters out of range	The Transition Parameters specified for the <i>TransitionParameter</i> input variable to a motion control instruction is out of range.	<ul style="list-style-type: none"> <i>TransitionParameter</i> is outside the setting range. 				S		W539
54015710 hex	Kinematics Transform Not Set	The kinematics transform is not set for the specified axes group.	<ul style="list-style-type: none"> The kinematics transform is not set for the axes group. 				S		W539
54015711 hex	Target Position Out of Range	The position parameter specified as variable for the Position is out of range.	<ul style="list-style-type: none"> Specified wrong value of Position input. 				S		W539
54015712 hex	Velocity Error Detection Value Out of Range	<i>MaxVelocity</i> specified for the <i>TrajData</i> input variable to a motion control instruction is out of range.	<ul style="list-style-type: none"> <i>MaxVelocity</i> is outside the setting range. 				S		W539
54015713 hex	Acceleration Error Detection Value Out of Range	<i>MaxAcceleration</i> specified for the <i>TrajData</i> input variable to a motion control instruction is out of range.	<ul style="list-style-type: none"> <i>MaxAcceleration</i> is outside the setting range. 				S		W539
54015714 hex	Trajectory Target Time Out of Range	<i>TrajTime</i> specified for the <i>TrajData</i> input variable to a motion control instruction is out of range.	<ul style="list-style-type: none"> <i>TrajTime</i> is outside the setting range. 				S		W539
54015715 hex	Trajectory Type Out of Range	<i>MoveTrajType</i> specified for the <i>TrajData</i> input variable to a motion control instruction is out of range.	<ul style="list-style-type: none"> <i>MoveTrajType</i> or <i>SyncTrajType</i> is outside the setting range. 				S		W539
54015716 hex	Trajectory Transition Out of Range	<i>TrajTransition</i> specified for the <i>TrajData</i> input variable to a motion control instruction is out of range.	<ul style="list-style-type: none"> <i>TrajTransition</i> is outside the setting range. 				S		W539
54015717 hex	Trajectory Travel Distance Out of Range	<i>TrajDistance</i> specified for the <i>TrajData</i> input variable to a motion control instruction is out of range.	<ul style="list-style-type: none"> <i>TrajDistance</i> is outside the setting range. 				S		W539
54015719 hex	Initial Workpiece Position Outside Workspace	The position of the workpiece specified for the <i>InitWorkpiecePosition</i> input variable to a motion control instruction is outside the workspace.	<ul style="list-style-type: none"> <i>InitWorkpiecePosition</i> is outside the workspace. 				S		W539

Event code	Event name	Meaning	Assumed cause	Level					Reference
				Maj	Prt	Min	Obs	Info	
5401571A hex	Invalid Conveyor Axis Specified	The axis specified for the <i>ConveyorAxis</i> input variable to a motion control instruction is not correct.	<ul style="list-style-type: none"> The specified axis is registered in the axes group which is specified for <i>AxesGroup</i>. The specified axis is an unused axis. The unit of the conveyor axis is incorrect. 				S		W539
5401571B hex	Target Position Outside Workspace	The target position specified for the <i>Position</i> input variable to a motion control instruction is outside the workspace.	<ul style="list-style-type: none"> <i>Position</i> is outside the workspace. 				S		W539
5401571C hex	Cannot Cancel Synchronization	The MC_SyncOut instruction cannot be executed.	<ul style="list-style-type: none"> The MC_SyncLinear-Conveyor instruction was not executed. The MC_SyncLinear-Conveyor instruction execution is in progress, but synchronization is not currently performed. 				S		W539
5401571E hex	Too Many Kinematics	The number of kinematics exceeded the limit.	<ul style="list-style-type: none"> The number kinematics set by the MC_SetKinTransform instruction exceeded the limit. 				S		W539
5401571F hex	Kinematics Initialization Error	Kinematics initialization failed.	<ul style="list-style-type: none"> One of the robot axes (A0 to A3) is stopped at the position for which direct kinematics calculation cannot be performed. 				S		W539
54015732 hex	Invalid Tool Number	The tool ID specified for the <i>ToolID</i> input variable to a motion control instruction is out of range or not defined.	<ul style="list-style-type: none"> <i>ToolID</i> is outside the setting range. The specified tool ID is not defined by the MC_DefineToolTransform instruction. 				S		W539
54015733 hex	Tool Parameter Out of Range	The transform parameter specified for the <i>ToolTransform</i> input variable to a motion control instruction is out of range.	<ul style="list-style-type: none"> The transform parameter is outside the setting range. 				S		W539
54015736 hex	Offset Not Allowed	During the MC_SyncLinearConveyor instruction execution, the offset function can be used only in Phase6.	<ul style="list-style-type: none"> The <i>EnableOffset</i> input variable changed to TRUE before the MC_SyncLinearConveyor instruction operation entered Phase6. 				S		W539
54015744 hex	Jog Mode Out of Range	The <i>JogMode</i> input variable to the MC_RobotJog instruction is out of range.	<ul style="list-style-type: none"> The <i>JogMode</i> input variable to the MC_RobotJog instruction is outside the setting range. 				S		W539
54015745 hex	Initial Workpiece Position Out of Range	The <i>InitWorkpiecePosition</i> input variable to the MC_SyncLinearConveyor instruction is out of range.	<ul style="list-style-type: none"> The <i>InitWorkpiecePosition</i> input variable to the MC_SyncLinearConveyor instruction is outside the setting range. 				S		W539
54015746 hex	Maximum Interpolation Velocity Out of Range	The <i>MaxVelocityTCP</i> input variable to the MC_SetKinTransform instruction is out of range.	<ul style="list-style-type: none"> The <i>MaxVelocityTCP</i> input variable to the MC_SetKinTransform instruction is outside the setting range. 				S		W539

Event code	Event name	Meaning	Assumed cause	Level					Reference
				Maj	Prt	Min	Obs	Info	
54015747 hex	Maximum Interpolation Acceleration Out of Range	The <i>MaxAccelerationTCP</i> input variable to the MC_SetKinTransform instruction is out of range.	<ul style="list-style-type: none"> The <i>MaxAccelerationTCP</i> input variable to the MC_SetKinTransform instruction is outside the setting range. 				S		W539
54015748 hex	Maximum Interpolation Deceleration Out of Range	The <i>MaxDecelerationTCP</i> input variable to the MC_SetKinTransform instruction is out of range.	<ul style="list-style-type: none"> The <i>MaxDecelerationTCP</i> input variable to the MC_SetKinTransform instruction is outside the setting range. 				S		W539
54016443 hex	Positive Limit Input	An instruction was executed for a motion in the positive direction when the positive limit input was ON.	<ul style="list-style-type: none"> An instruction for a motion in the positive direction was executed when the positive limit input was ON, or an instruction for a motion with no direction specification was executed when the positive limit input was ON. An axes group motion control instruction was executed when the positive limit input was ON. 				S		W539
54016444 hex	Negative Limit Input	An instruction for a motion in the negative direction was executed when the negative limit input was ON.	<ul style="list-style-type: none"> An instruction for a motion in the negative direction was executed when the negative limit input was ON, or an instruction for a motion with no direction specification was executed when the negative limit input was ON. An axes group motion control instruction was executed when the negative limit input was ON. 				S		W539
54016701 hex	Current Position Outside Workspace	The current position was outside the workspace when an instruction was executed.	<ul style="list-style-type: none"> The current position was outside the workspace when one of the following instructions was executed. MC_MoveTimeAbsolute MC_SyncLinearConveyor MC_SyncOut MC_RobotJog 				S		W539

3-1-11 Errors in CNC Function

This section provides tables of the errors (events) that can occur in the CNC functions and CNC instructions.

You can use the CNC functions and CNC instructions with an NJ501-5300 Controller. The unit version of the CPU Unit is 1.16 or later.

CNC Function

The manual names are given below for the catalog numbers given in the *Reference* column of the event table.

Cat. No.	Manual name
O030	NJ/NY-series NC Integrated Controller User's Manual

Event code	Event name	Meaning	Assumed cause	Level					Reference
				Maj	Prt	Min	Obs	Info	
47810000 hex	CNC Parameter Setting Invalid	A fatal error was detected during setting of the CNC Function Module.	<ul style="list-style-type: none"> The system failed to transfer the CNC parameter setting. Otherwise, an error occurred in the software. 	S					O030
17800000 hex	CNC Parameter Setting Error	The CNC parameters that were saved in non-volatile memory are missing.	<ul style="list-style-type: none"> The power supply to the Controller was interrupted or communications with the Sysmac Studio were disconnected while downloading the CNC parameter settings or clearing memory. Non-volatile memory failure 		S				O030
17810000 hex	Absolute Encoder Home Offset Read Error	The absolute encoder current position that is retained during power interruptions was lost.	<ul style="list-style-type: none"> When the retained variables are backed up with a battery, this event indicates that the life of the battery in the CPU Unit has expired. Backup memory failure 		S				O030
17820000 hex	CNC Motor Compensation Table Read Error	The CNC motor compensation table that was saved in non-volatile memory is missing.	<ul style="list-style-type: none"> The power supply to the Controller was interrupted or communications with the Sysmac Studio were disconnected while downloading the CNC parameter settings or clearing memory. Non-volatile memory failure 		S				O030
37800000 hex	Required Process Data Object Not Set	The object that is required for the assigned axis type in the CNC motor parameter settings is not allocated to PDO.	<ul style="list-style-type: none"> The required PDOs are not mapped when the assigned axis type in the CNC motor parameter settings is set to a servo axis or encoder axis. Non-volatile memory failure 		S				O030
47800000 hex	CNC Initialization Error	A fatal error occurred in the system and prevented initialization of the CNC Function Module.	<ul style="list-style-type: none"> Hardware has failed. 		S				O030
77800000 hex	CNC Control Period Exceeded	Processing for the primary periodic task was not finished within two control periods.	<ul style="list-style-type: none"> The processing load in the primary periodic task is too heavy. 		S				O030

Event code	Event name	Meaning	Assumed cause	Level					Reference
				Maj	Prt	Min	Obs	Info	
37810000 hex	Process Data Object Setting Missing	The PDO mapping is not correct.	<ul style="list-style-type: none"> The PDOs that are required for the CNC instruction are not mapped. The relevant instruction was executed for a device that does not have an object that supports the instruction. 			S			O030
56000000 hex	Illegal CNC Coordinate System Specification	The CNC coordinate system specified for the <i>Coord</i> in-out variable to a CNC instruction does not exist.	<ul style="list-style-type: none"> CNC coordinate system does not exist for the variable specified for the <i>Coord</i> in-out variable to the instruction. 			S			O030
56010000 hex	Deceleration Setting Out of Range	The parameter specified for the <i>Deceleration</i> input variable to a CNC instruction is out of range.	<ul style="list-style-type: none"> Instruction input parameter exceeded the valid range of the input variable. 			S			O030
56020000 hex	Jerk Setting Out of Range	The parameter specified for the <i>Jerk</i> input variable to a CNC instruction is out of range.	<ul style="list-style-type: none"> Instruction input parameter exceeded the valid range of the input variable. 			S			O030
56030000 hex	CNC Instruction Re-execution Disabled	A CNC instruction that cannot be re-executed was re-executed.	<ul style="list-style-type: none"> A CNC instruction that cannot be re-executed was re-executed. 			S			O030
56040000 hex	CNC Multi-execution Disabled	Multiple functions that cannot be executed simultaneously were executed for the same target (CNC coordinate system).	<ul style="list-style-type: none"> Multiple functions that cannot be executed simultaneously were executed for the same target (CNC coordinate system). The CNC_LoadProgramFile instruction was executed when any of CNC coordinate system was <i>Executing</i> (Executing) or <i>Hold</i> (Holding). 			S			O030
56050000 hex	Unassigned Logical CNC Motor Number Specified	The CNC motor of the parameter specified for the <i>LogicalMotorNo</i> input variable to the CNC instruction is not assigned.	<ul style="list-style-type: none"> The logical CNC motor number for which the CNC motor is not assigned to the <i>LogicalMotorNo</i> input variable to the CNC instruction was specified, and the instruction was executed. 			S			O030
56060000 hex	Logical CNC Motor Number Out of Range	The parameter specified for the <i>LogicalMotorNo</i> input variable to a CNC instruction is out of range.	<ul style="list-style-type: none"> Instruction input parameter exceeded the valid range of the input variable. 			S			O030
56070000 hex	Target Position Setting Out of Range	The parameter specified for the Position input variable to a CNC instruction is out of range.	<ul style="list-style-type: none"> Instruction input parameter exceeded the valid range of the input variable. Or, there was an overflow/underflow in the target position. 			S			O030

Event code	Event name	Meaning	Assumed cause	Level					Reference
				Maj	Prt	Min	Obs	Info	
56080000 hex	Impossible CNC Motor Operation Specified when the Servo is OFF	An operation instruction was executed for the CNC motor for which the Servo is OFF.	<ul style="list-style-type: none"> An operation instruction was executed for the CNC motor for which the Servo is OFF. Home was preset with the CNC_Home or CNC_HomeWithParameter instruction for an axis for which EtherCAT process data communications are not established. 			S			O030
56090000 hex	Target Velocity Setting Out of Range	The parameter specified for the <i>Velocity</i> input variable to a CNC instruction is out of range.	<ul style="list-style-type: none"> Instruction input parameter exceeded the valid range of the input variable. 			S			O030
560A0000 hex	Acceleration/Deceleration Setting Out of Range	The parameter specified for the <i>Acceleration</i> input variable to a CNC instruction is out of range.	<ul style="list-style-type: none"> Instruction input parameter exceeded the valid range of the input variable. 			S			O030
560B0000 hex	Travel Mode Selection Out of Range	The parameter specified for the <i>MoveMode</i> input variable to a CNC instruction is out of range.	<ul style="list-style-type: none"> Instruction input parameter exceeded the valid range of the input variable. 			S			O030
560C0000 hex	Immediate Stop Instruction Executed	An Immediate Stop (CNC_ImmediateStop) instruction was executed.	<ul style="list-style-type: none"> An Immediate Stop instruction was executed. 			S			O030
560D0000 hex	Parameter Selection Out of Range	The parameter specified for the <i>ParameterNumber</i> input variable to a CNC instruction is out of range.	<ul style="list-style-type: none"> Instruction input parameter exceeded the valid range of the input variable. 			S			O030
560E0000 hex	CNC Parameter Setting Read/Write Setting Value Out of Range	The parameter specified for the <i>SettingValue</i> in-out variable to a CNC instruction is out of range.	<ul style="list-style-type: none"> Instruction input parameter exceeded the valid range of the in-out variable. 			S			O030
560F0000 hex	CNC Parameter Setting Read/Write Target Out of Range	The parameter specified for the <i>Target</i> in-out variable to a CNC instruction is out of range.	<ul style="list-style-type: none"> Instruction input parameter exceeded the valid range of the in-out variable. 			S			O030
56100000 hex	Cycle Start Error with Undefined Home	A cycle start was executed for a CNC coordinate system including the positioning axis with no defined home.	<ul style="list-style-type: none"> A cycle start was executed for a CNC coordinate system including the positioning axis with no defined home. 			S			O030
56110000 hex	Homing Parameter Setting Out of Range	The parameter specified for the <i>HomingParameter</i> in-out variable to a CNC instruction is out of range.	<ul style="list-style-type: none"> Instruction input parameter exceeded the valid range of the in-out variable. 			S			O030

Event code	Event name	Meaning	Assumed cause	Level					Reference
				Maj	Prt	Min	Obs	Info	
56120000 hex	M Code Number Out of Range	The parameter specified for the <i>MCodeNo</i> input variable to a CNC instruction is out of range.	<ul style="list-style-type: none"> Instruction input parameter exceeded the valid range of the input variable. 			S			O030
56130000 hex	CNC Instruction Re-execution Disabled (CNC Coordinate System Specification)	An attempt was made to change the parameter for the <i>Coord</i> in-out variable when re-executing a CNC instruction. (This in-out variable cannot be changed when re-executing an instruction.)	<ul style="list-style-type: none"> A parameter for an in-out variable that cannot be changed for re-execution was changed. 			S			O030
56140000 hex	CNC Instruction Re-execution Disabled (Logical CNC Motor Number)	An attempt was made to change the parameter for the <i>LogicalMotorNo</i> input variable when re-executing a CNC instruction. (This input variable cannot be changed when re-executing an instruction.)	<ul style="list-style-type: none"> A parameter for an input variable that cannot be changed for re-execution was changed. 			S			O030
56150000 hex	Illegal NC Program	An error was detected in the NC program transferred from Sysmac Studio.	<ul style="list-style-type: none"> NC program transfer processing failed. 			S			O030
56160000 hex	Cycle Start Multi-execution Disabled	A cycle start was executed multiple times for the same target (CNC coordinate system).	<ul style="list-style-type: none"> A cycle start was executed while the CNC coordinate system is <i>Executing</i> (Executing), <i>MovingOnHold</i> (Manual Operation While Holding), or <i>Moving</i> (Moving). 			S			O030
56170000 hex	Impossible CNC Motor Cycle Start Specified when the Servo is OFF	A cycle start was executed for a CNC coordinate system including the CNC motor for which the Servo is OFF.	<ul style="list-style-type: none"> A cycle start was executed for the CNC motor for which Servo is turned OFF. 			S			O030
56180000 hex	Illegal NC Program Number Specification	The NC program specified for <i>ProgramNo</i> in the <i>ControlInputs</i> in-out variable to the CNC_CoordControl instruction is not loaded.	<ul style="list-style-type: none"> A cycle start was executed after an unloaded NC program is specified for <i>ProgramNo</i> in the <i>ControlInputs</i> in-out variable to the CNC_CoordControl instruction. 			S			O030
56190000 hex	Illegal Back Trace Specification	A cycle start was executed when the CNC coordinate system is <i>Standby</i> (Standby) while <i>BackTrace</i> in the <i>ControlInputs</i> in-out variable to the CNC_CoordControl instruction is set to TRUE.	<ul style="list-style-type: none"> A cycle start was executed when the CNC coordinate system is <i>Standby</i> (Standby) while <i>BackTrace</i> in the <i>ControlInputs</i> in-out variable to the CNC_CoordControl instruction is set to TRUE. 			S			O030

Event code	Event name	Meaning	Assumed cause	Level					Reference
				Maj	Prt	Min	Obs	Info	
56250000 hex	Illegal CNC Motor Specification	The CNC motor specified for the <i>Target</i> in-out variable to a CNC instruction is not exist.	<ul style="list-style-type: none"> A CNC motor does not exist for the variable specified for the <i>Target</i> input variable to the instruction. 			S			O030
56260000 hex	Illegal CNC Motor Compensation Table Specification	The CNC motor compensation table specified for the <i>Target</i> input variable to a CNC instruction is not exist.	<ul style="list-style-type: none"> A CNC motor compensation table does not exist for the variable specified for the <i>Target</i> input variable to the instruction. 			S			O030
56290000 hex	NC Program Capacity Exceeded	Loading failed because the NC program downloaded from Sysmac Studio exceeded the maximum capacity.	<ul style="list-style-type: none"> The NC program over the maximum capacity was downloaded from Sysmac Studio. 			S			O030
67800000 hex	Immediate Stop Input	The immediate stop input turned ON.	<ul style="list-style-type: none"> An immediate stop input signal was detected. The immediate stop input signal is not connected correctly or the logic setting for the immediate stop input is wrong. 			S			O030
67810000 hex	Positive Limit Input Detected	The positive limit input turned ON.	<ul style="list-style-type: none"> A positive limit input signal was detected. The positive limit input signal is not connected correctly or the logic setting for the positive limit input is wrong. 			S			O030
67820000 hex	Negative Limit Input Detected	The negative limit input turned ON.	<ul style="list-style-type: none"> A negative limit input signal was detected. The negative limit input signal is not connected correctly or the logic setting for the negative limit input is wrong. 			S			O030
67830000 hex	Target Position Positive Software Limit Exceeded	The specified position exceeds the positive software limit.	<ul style="list-style-type: none"> The parameter specified for the <i>Position</i> input variable to the instruction is beyond the positive software limit. The first position is beyond the positive software limit and an instruction that specifies motion in the opposite direction of the software limit was executed. 			S			O030
67840000 hex	Target Position Negative Software Limit Exceeded	The specified position exceeds the negative software limit.	<ul style="list-style-type: none"> The parameter specified for the <i>Position</i> input variable to the instruction is beyond the negative software limit. The first position is beyond the negative software limit and an instruction that specifies motion in the opposite direction of the software limit was executed. 			S			O030

Event code	Event name	Meaning	Assumed cause	Level					Reference
				Maj	Prt	Min	Obs	Info	
67850000 hex	Command Position Over-flow/Under-flow	Positioning, an instruction in the underflow/overflow direction, or an instruction for which the direction is not specified was executed when there was an underflow/overflow in the command position.	<ul style="list-style-type: none"> One of the following was executed when there was a command position overflow/underflow. <ul style="list-style-type: none"> A positioning instruction A continuous control instruction in the underflow/overflow direction An instruction for which the direction is not specified (syncing) 			S			O030
67860000 hex	Positive Limit Input	An instruction was executed for a motion in the positive direction when the positive limit input was ON.	<ul style="list-style-type: none"> An instruction for a motion in the positive direction was executed when the positive limit input was ON, or an instruction for a motion with no direction specification was executed when the positive limit input was ON. 			S			O030
67870000 hex	Negative Limit Input	An instruction for a motion in the negative direction was executed when the negative limit input was ON.	<ul style="list-style-type: none"> An instruction for a motion in the negative direction was executed when the negative limit input was ON, or an instruction for a motion with no direction specification was executed when the negative limit input was ON. 			S			O030
67880000 hex	Positive Software Limit Exceeded	The position exceeded the positive software limit while the CNC motor is in motion.	<ul style="list-style-type: none"> The position exceeded the positive software limit. 			S			O030
67890000 hex	Negative Software Limit Exceeded	The position exceeded the negative software limit while the CNC motor is in motion.	<ul style="list-style-type: none"> The position exceeded the negative software limit. 			S			O030
678A0000 hex	In-position Check Time Exceeded	The in-position check was not completed within the monitoring time.	<ul style="list-style-type: none"> Time is required to complete positioning. 			S			O030
678B0000 hex	Following Error Limit Exceeded	The error between the command current position and actual current value exceeded the Following Error Over Value.	<ul style="list-style-type: none"> The positioning operation has poor following performance and the actual motion is slower than the command. 			S			O030
67910000 hex	Illegal Following Error	The difference between the command position and the actual current position exceeds the range of 30-bit data when converted to pulses.	<ul style="list-style-type: none"> The command current position was restricted so that the velocity of the CNC motor would not exceed the maximum velocity for the specified travel distance. The CNC motor positioning operation has poor following performance and the actual motion is slower than the command. 			S			O030

Event code	Event name	Meaning	Assumed cause	Level					Reference
				Maj	Prt	Min	Obs	Info	
67920000 hex	Absolute Encoder Current Position Calculation Failed	It was not possible to correctly restore the current position from the absolute encoder information that was saved when power was interrupted.	<ul style="list-style-type: none"> The position to restore when converted to pulses exceeded the range of signed 40-bit data. 			S			O030
67930000 hex	Home Undefined during Coordinated Motion	Home of the CNC motor became undefined while the status of CNC coordinate system is <i>Executing</i> (Executing), <i>MovingOnHold</i> (Manual Operation While Holding), or <i>Moving</i> (Moving).	<ul style="list-style-type: none"> The command position or actual position overflowed or underflowed for a CNC motor while the status of CNC coordinate system is <i>Executing</i> (Executing), <i>MovingOnHold</i> (Manual Operation While Holding), or <i>Moving</i> (Moving) and the home definition was lost. A slave communications error occurred in the CNC motor and the home become undefined while the status of CNC coordinate system is <i>Executing</i> (Executing), <i>MovingOnHold</i> (Manual Operation While Holding), or <i>Moving</i> (Moving). A slave for a logical axis left the network or was disabled and home became undefined while the status of CNC coordinate system is <i>Executing</i> (Executing), <i>MovingOnHold</i> (Manual Operation While Holding), or <i>Moving</i> (Moving). 			S			O030
67940000 hex	Cycle Start Specified during Positive Software Limit Exceeded	The first position exceeds the positive software limit.	<ul style="list-style-type: none"> The command current position of the positioning cartesian axis or positioning rotational axis in the CNC coordinate system is out of range of the positive software limit. 			S			O030
67950000 hex	Cycle Start Specified during Negative Software Limit Exceeded	The first position exceeds the negative software limit.	<ul style="list-style-type: none"> The command current position of the positioning cartesian axis or positioning rotational axis in the CNC coordinate system is out of range of the negative software limit. 			S			O030
67960000 hex	Cycle Start Specified during Command Position Overflow/Underflow	Positioning, an instruction in the underflow/overflow direction, or an instruction for which the direction is not specified was executed when there was an underflow/overflow in the command position.	<ul style="list-style-type: none"> One of the following was executed when there was a command position overflow/underflow. <ul style="list-style-type: none"> A positioning instruction A continuous control instruction in the underflow/overflow direction An instruction for which the direction is not specified (syncing) 			S			O030
67970000 hex	Cycle Start Specified during Positive Limit Input	A cycle start was executed when the positive limit input was ON.	<ul style="list-style-type: none"> A cycle start was executed when the positive limit input was ON. 			S			O030

Event code	Event name	Meaning	Assumed cause	Level					Reference
				Maj	Prt	Min	Obs	Info	
67980000 hex	Cycle Start Specified during Negative Limit Input	A cycle start was executed when the negative limit input was <i>ON</i> .	<ul style="list-style-type: none"> A cycle start was executed when the negative limit input was <i>ON</i>. 			S			O030
67990000 hex	NC Program Execution Error	An error was detected while the NC program is running.	<ul style="list-style-type: none"> An error was detected while the NC program is running. Refer to error codes in the following attached information for details on errors. 			S			O030
77820000 hex	CNC Coordinate System Composition CNC Motor Error	An error occurred for a composition CNC motor in a CNC coordinate system.	<ul style="list-style-type: none"> An error occurred for a composition CNC motor in a CNC coordinate system while it is moving. 			S			O030
77830000 hex	CNC Common Error Occurrence	A CNC common error occurred.	<ul style="list-style-type: none"> Partial fault level CNC common error occurred. 			S			O030
77840000 hex	Servo Main Circuits OFF	An attempt was made to turn <i>ON</i> the Servo when the main circuit power supply to the Servo Drive was <i>OFF</i> .	<ul style="list-style-type: none"> An attempt was made to turn <i>ON</i> the Servo when the main circuit power supply to the Servo Drive was <i>OFF</i>. 			S			O030
77850000 hex	Servo Main Circuit Power OFF	The main circuit power of the Servo Drive turned <i>OFF</i> while the Servo was <i>ON</i> .	<ul style="list-style-type: none"> The main circuit power of the Servo Drive was interrupted while the Servo was <i>ON</i>. 			S			O030
77860000 hex	Slave Error Detected	An error was detected for the EtherCAT slave or NX Unit that is allocated to the CNC motor.	<ul style="list-style-type: none"> An error was detected for the EtherCAT slave or NX Unit that is allocated to the CNC motor. 			S			O030
77880000 hex	Slave Disconnection during Servo <i>ON</i>	An EtherCAT slave or NX Unit that is allocated to the CNC motor was disconnected, replaced, or disabled while the Servo was <i>ON</i> .	<ul style="list-style-type: none"> An EtherCAT slave or NX Unit that is allocated to the CNC motor was disconnected, replaced, or disabled while the Servo was <i>ON</i>. 			S			O030
77890000 hex	Homing Opposite Direction Limit Input Detected	The limit signal in the direction opposite to the homing direction was detected during a homing operation.	<ul style="list-style-type: none"> The Operation Selection at Negative Limit Input or Operation Selection at Positive Limit Input parameter is set to <i>No reverse turn</i>. The location of the homing input signal sensors, homing settings, and homing start position cause a limit input to be reached. The input signal sensor wiring is incorrect or the sensor is faulty. 			S			O030

Event code	Event name	Meaning	Assumed cause	Level					Reference
				Maj	Prt	Min	Obs	Info	
778A0000 hex	Homing Direction Limit Input Detected	The limit signal in the homing direction was detected during a homing operation.	<ul style="list-style-type: none"> The Operation Selection at Negative Limit Input or Operation Selection at Positive Limit Input parameter is set to <i>No reverse turn</i>. The location of the homing input signal sensors, homing settings, and homing start position cause a limit input to be reached. The input signal sensor wiring is incorrect or the sensor is faulty. 			S			O030
778B0000 hex	Homing Limit Inputs Detected in Both Directions	The limit signals in both directions were detected during a homing operation.	<ul style="list-style-type: none"> The wiring of the limit signal is incorrect. The limit sensor is installed in the wrong location. The contact logic of the limit signal is not correct. The limit sensor failed. 			S			O030
778C0000 hex	Home Proximity/Homing Opposite Direction Limit Input Detected	The home proximity input and the limit signal in the direction opposite to the homing direction were detected at the same time during a homing operation.	<ul style="list-style-type: none"> The wiring of the home proximity signal or limit signal is incorrect. The home proximity sensor or limit sensor is installed in the wrong location. The contact logic of the home proximity signal or limit signal is not correct. The home proximity sensor or limit sensor failed. 			S			O030
778D0000 hex	Home Proximity/Homing Direction Limit Input Detected	The home proximity input and the limit signal in the homing direction were detected at the same time during a homing operation.	<ul style="list-style-type: none"> The wiring of the home proximity signal or limit signal is incorrect. The home proximity sensor or limit sensor is installed in the wrong location. The contact logic of the home proximity signal or limit signal is not correct. The home proximity sensor or limit sensor failed. 			S			O030
778E0000 hex	Home Input/Homing Opposite Direction Limit Input Detected	The home input and the limit signal in the direction opposite to the homing direction were detected at the same time during a homing operation.	<ul style="list-style-type: none"> The wiring of the home input signal or limit signal is incorrect. The home input sensor or limit sensor is installed in the wrong location. The contact logic of the home input signal or limit signal is not correct. The home input signal output device or limit sensor failed. 			S			O030
778F0000 hex	Home Input/Homing Direction Limit Input Detected	The home input and the limit signal in the homing direction were detected at the same time during a homing operation.	<ul style="list-style-type: none"> The wiring of the home input signal or limit signal is incorrect. The home input sensor or limit sensor is installed in the wrong location. The contact logic of the home input signal or limit signal is not correct. The home input signal output device or limit sensor failed. 			S			O030

Event code	Event name	Meaning	Assumed cause	Level					Reference
				Maj	Prt	Min	Obs	Info	
77900000 hex	Invalid Home Input Mask Distance	The setting of the home input mask distance is not suitable for the CNC_Home or CNC_HomeWith-Parameter instruction.	<ul style="list-style-type: none"> The set value of the home input mask distance when the operating mode of the MC_Home instruction is set to <i>Proximity Reverse Turn/Home Input Mask Distance</i> is insufficient to decelerate from the homing velocity to the homing approach velocity. 			S			O030
77910000 hex	No Home Input	There was no home signal input during the homing operation. Or, a limit signal was detected before there was a home input.	<ul style="list-style-type: none"> There was no home signal input during the homing operation. A limit signal was detected before there was a home input 			S			O030
77920000 hex	No Home Proximity Input	There was no home proximity signal input during the homing operation.	<ul style="list-style-type: none"> There was no home proximity signal input during the homing operation when a home proximity input signal was specified. 			S			O030
87800000 hex	EtherCAT Slave Communications Error	A communications error occurred for the EtherCAT slave or NX Unit that is allocated to a CNC motor.	<ul style="list-style-type: none"> A communications error occurred for the EtherCAT slave or NX Unit that is allocated to a CNC motor. 			S			O030
561D0000 hex	SD Memory Card Access Failure	SD Memory Card access failed when an instruction was executed.	<ul style="list-style-type: none"> An SD Memory Card is not inserted. The SD Memory Card is damaged. The SD Memory Card slot is broken. 				S		O030
561E0000 hex	File Does Not Exist	The file specified for an instruction does not exist.	<ul style="list-style-type: none"> The specified file does not exist. 				S		O030
561F0000 hex	Illegal Load NC Program Number Specification	Loading failed because an attempt was made to load the NC program with an invalid program number specified.	<ul style="list-style-type: none"> An attempt was made to load the NC program with an invalid program number specified. 				S		O030
56200000 hex	Too Many Files Open	The maximum number of open files was exceeded when opening a file for an instruction.	<ul style="list-style-type: none"> The maximum number of open files was exceeded when opening a file for an instruction. 				S		O030
56210000 hex	File or Directory Name Is Too Long	The file name or directory name that was specified for an instruction is too long.	<ul style="list-style-type: none"> The file name or directory name that was specified for the instruction to create is too long. 				S		O030
56220000 hex	SD Memory Card Access Failed	SD Memory Card access failed.	<ul style="list-style-type: none"> The SD Memory Card is damaged. The SD Memory Card slot is broken. 				S		O030
56230000 hex	Load NC Program Capacity Exceeded	Loading failed because an attempt was made to load the NC program over the maximum capacity.	<ul style="list-style-type: none"> An attempt was made to load the NC program over the maximum capacity. 				S		O030

Event code	Event name	Meaning	Assumed cause	Level					Reference
				Maj	Prt	Min	Obs	Info	
56240000 hex	Number of NC Program Exceeded	Loading failed because an attempt was made to load NC programs over the maximum number of NC programs.	<ul style="list-style-type: none"> A new NC program was loaded while the number of loaded NC programs reaches the maximum. 				S		O030
56280000 hex	Illegal Load NC Program	An error was detected in the loaded NC program.	<ul style="list-style-type: none"> A syntax error was detected in the NC program you made an attempt to load. 				S		O030
678C0000 hex	Following Error Warning	The following error exceeded the Following Error Warning Value.	<ul style="list-style-type: none"> The positioning operation has poor following performance and the actual motion is slower than the command. 				S		O030
678D0000 hex	Command Position Overflow	The number of pulses for the command position overflowed.	<ul style="list-style-type: none"> When the command position was converted to the pulse unit for the positioning cartesian axis or positioning rotational axis, the specified value exceeded the upper limit of the signed 40-bit data (signed 54-bit data for the spindle axis). 				S		O030
678E0000 hex	Command Position Underflow	The number of pulses for the command position exceeded the valid range. (It underflowed.)	<ul style="list-style-type: none"> When the command position was converted to the pulse unit for the positioning cartesian axis or positioning rotational axis, the specified value exceeded the lower limit of the signed 40-bit data (signed 54-bit data for the spindle axis). 				S		O030
678F0000 hex	Actual Position Overflow	The number of pulses for the actual position overflowed.	<ul style="list-style-type: none"> When the command position was converted to the pulse unit for the positioning cartesian axis or positioning rotational axis, the specified value exceeded the upper limit of the signed 40-bit data (signed 54-bit data for the spindle axis). 				S		O030
67900000 hex	Actual Position Underflow	The number of pulses for the actual position underflowed.	<ul style="list-style-type: none"> When the command position was converted to the pulse unit for the positioning cartesian axis or positioning rotational axis, the specified value exceeded the lower limit of the signed 40-bit data (signed 54-bit data for the spindle axis). 				S		O030
77810000 hex	CNC Planner Service Period Exceeded	CNC planner service processing was not finished within two periods.	<ul style="list-style-type: none"> The processing load of the NC program in a period of the CNC planner service is too heavy. 				S		O030
77870000 hex	Slave Observation Detected	A warning was detected for an EtherCAT slave or NX Unit.	<ul style="list-style-type: none"> A warning was detected for the EtherCAT slave or NX Unit that is allocated to a CNC motor. 				S		O030
97810000 hex	Software Limit Path Limited	The path exceeded the software limit was specified during <i>Executing</i> (Executing). Therefore, the path was limited within the software limit range.	<ul style="list-style-type: none"> The path exceeded the software limit was specified during <i>Executing</i> (Executing). 				S		O030

Event code	Event name	Meaning	Assumed cause	Level					Reference
				Maj	Prt	Min	Obs	Info	
97830000 hex	Velocity Control Command Value Saturated	The velocity control command value for the servo drive is saturated.	<ul style="list-style-type: none"> The output value for Feedback loop calculation exceeded the Maximum Velocity for the CNC motor parameter setting, or the positioning operation has poor following performance and the actual motion is slower than the command. The commanded master axis rotation rate (S) or master axis velocity override factor exceeded the Maximum Velocity for the CNC motor parameter setting. 				S		O030
97800000 hex	Slave Error Code Report	The error code was reported by the slave when a <i>Slave Error Detected</i> error occurred.	<ul style="list-style-type: none"> The error code was reported by the slave when a <i>Slave Error Detected</i> error (77860000 hex) occurred. 					S	O030
97820000 hex	CNC Function System Information	This event provides internal information from the CNC Function Module.	<ul style="list-style-type: none"> This event provides internal information from the CNC Function Module. It is recorded to provide additional information for another event. 					S	O030

CNC Instructions

The following provides a table of errors (events) that can occur in the CNC instructions. The lower four digits of the event code give the error code for the instruction. For descriptions of an error code, refer to the description of the corresponding event code. For example, if the error code of the instruction is 16#3781, refer to the description of the event with event code 54013781 hex.

The manual names are given below for the catalog numbers given in the *Reference* column of the event table.

Cat. No.	Manual name
O030	NJ/NY-series NC Integrated Controller User's Manual

Event code	Event name	Meaning	Assumed cause	Level					Reference
				Maj	Prt	Min	Obs	Info	
54013781 hex	Process Data Object Setting Missing	The PDO mapping is not correct.	<ul style="list-style-type: none"> The PDOs that are required for the CNC instruction are not mapped. The relevant instruction was executed for a device that does not have an object that supports the instruction. 				S		O030
54015600 hex	Illegal CNC Coordinate System Specification	The CNC coordinate system specified for the <i>Coord</i> in-out variable to a CNC instruction does not exist.	<ul style="list-style-type: none"> CNC coordinate system does not exist for the variable specified for the <i>Coord</i> in-out variable to the instruction. 				S		O030
54015601 hex	Deceleration Setting Out of Range	The parameter specified for the <i>Deceleration</i> input variable to a CNC instruction is out of range.	<ul style="list-style-type: none"> Instruction input parameter exceeded the valid range of the input variable. 				S		O030

3 Error Tables

Event code	Event name	Meaning	Assumed cause	Level					Reference
				Maj	Prt	Min	Obs	Info	
54015602 hex	Jerk Setting Out of Range	The parameter specified for the <i>Jerk</i> input variable to a CNC instruction is out of range.	<ul style="list-style-type: none"> Instruction input parameter exceeded the valid range of the input variable. 				S		O030
54015603 hex	CNC Instruction Re-execution Disabled	A CNC instruction that cannot be re-executed was re-executed.	<ul style="list-style-type: none"> A CNC instruction that cannot be re-executed was re-executed. 				S		O030
54015604 hex	CNC Multi-execution Disabled	Multiple functions that cannot be executed simultaneously were executed for the same target (CNC coordinate system).	<ul style="list-style-type: none"> Multiple functions that cannot be executed simultaneously were executed for the same target (CNC coordinate system). The <i>CNC_LoadProgramFile</i> instruction was executed when any of CNC coordinate system was <i>Executing</i> (Executing) or <i>Hold</i> (Holding). 				S		O030
54015605 hex	Unassigned Logical CNC Motor Number Specified	The CNC motor of the parameter specified for the <i>LogicalMotorNo</i> input variable to the CNC instruction is not assigned.	<ul style="list-style-type: none"> The logical CNC motor number for which the CNC motor is not assigned to the <i>LogicalMotorNo</i> input variable to the CNC instruction was specified, and the instruction was executed. 				S		O030
54015606 hex	Logical CNC Motor Number Out of Range	The parameter specified for the <i>LogicalMotorNo</i> input variable to a CNC instruction is out of range.	<ul style="list-style-type: none"> Instruction input parameter exceeded the valid range of the input variable. 				S		O030
54015607 hex	Target Position Setting Out of Range	The parameter specified for the <i>Position</i> input variable to a CNC instruction is out of range.	<ul style="list-style-type: none"> Instruction input parameter exceeded the valid range of the input variable. Or, there was an overflow/underflow in the target position. 				S		O030
54015608 hex	Impossible CNC Motor Operation Specified when the Servo is OFF	An operation instruction was executed for the CNC motor for which the Servo is OFF.	<ul style="list-style-type: none"> An operation instruction was executed for the CNC motor for which the Servo is OFF. Home was preset with the <i>CNC_Home</i> or <i>CNC_HomeWithParameter</i> instruction for an axis for which EtherCAT process data communications are not established. 				S		O030
54015609 hex	Target Velocity Setting Out of Range	The parameter specified for the <i>Velocity</i> input variable to a CNC instruction is out of range.	<ul style="list-style-type: none"> Instruction input parameter exceeded the valid range of the input variable. 				S		O030
5401560A hex	Acceleration/Deceleration Setting Out of Range	The parameter specified for the <i>Acceleration</i> input variable to a CNC instruction is out of range.	<ul style="list-style-type: none"> Instruction input parameter exceeded the valid range of the input variable. 				S		O030
5401560B hex	Travel Mode Selection Out of Range	The parameter specified for the <i>MoveMode</i> input variable to a CNC instruction is out of range.	<ul style="list-style-type: none"> Instruction input parameter exceeded the valid range of the input variable. 				S		O030

Event code	Event name	Meaning	Assumed cause	Level					Reference
				Maj	Prt	Min	Obs	Info	
5401560D hex	Parameter Selection Out of Range	The parameter specified for the <i>ParameterNumber</i> input variable to a CNC instruction is out of range.	<ul style="list-style-type: none"> Instruction input parameter exceeded the valid range of the input variable. 				S		O030
5401560E hex	CNC Parameter Setting Read/Write Setting Value Out of Range	The parameter specified for the <i>SettingValue</i> in-out variable to a CNC instruction is out of range.	<ul style="list-style-type: none"> Instruction input parameter exceeded the valid range of the in-out variable. 				S		O030
5401560F hex	CNC Parameter Setting Read/Write Target Out of Range	The parameter specified for the <i>Target</i> in-out variable to a CNC instruction is out of range.	<ul style="list-style-type: none"> Instruction input parameter exceeded the valid range of the in-out variable. 				S		O030
54015611 hex	Homing Parameter Setting Out of Range	The parameter specified for the <i>HomingParameter</i> in-out variable to a CNC instruction is out of range.	<ul style="list-style-type: none"> Instruction input parameter exceeded the valid range of the in-out variable. 				S		O030
54015612 hex	M Code Number Out of Range	The parameter specified for the <i>MCodeNo</i> input variable to a CNC instruction is out of range.	<ul style="list-style-type: none"> Instruction input parameter exceeded the valid range of the input variable. 				S		O030
54015613 hex	CNC Instruction Re-execution Disabled (CNC Coordinate System Specification)	An attempt was made to change the parameter for the <i>Coord</i> in-out variable when re-executing a CNC instruction. (This in-out variable cannot be changed when re-executing an instruction.)	<ul style="list-style-type: none"> A parameter for an in-out variable that cannot be changed for re-execution was changed. 				S		O030
54015614 hex	CNC Instruction Re-execution Disabled (Logical CNC Motor Number)	An attempt was made to change the parameter for the <i>LogicalMotorNo</i> input variable when re-executing a CNC instruction. (This input variable cannot be changed when re-executing an instruction.)	<ul style="list-style-type: none"> A parameter for an input variable that cannot be changed for re-execution was changed. 				S		O030
5401561D hex	SD Memory Card Access Failure	SD Memory Card access failed when an instruction was executed.	<ul style="list-style-type: none"> An SD Memory Card is not inserted. The SD Memory Card is damaged. The SD Memory Card slot is broken. 				S		O030
5401561E hex	File Does Not Exist	The file specified for an instruction does not exist.	<ul style="list-style-type: none"> The specified file does not exist. 				S		O030

Event code	Event name	Meaning	Assumed cause	Level					Reference
				Maj	Prt	Min	Obs	Info	
5401561F hex	Illegal Load NC Program Number Specification	Loading failed because an attempt was made to load the NC program with an invalid program number specified.	<ul style="list-style-type: none"> An attempt was made to load the NC program with an invalid program number specified. 				S		O030
54015620 hex	Too Many Files Open	The maximum number of open files was exceeded when opening a file for an instruction.	<ul style="list-style-type: none"> The maximum number of open files was exceeded when opening a file for an instruction. 				S		O030
54015621 hex	File or Directory Name Is Too Long	The file name or directory name that was specified for an instruction is too long.	<ul style="list-style-type: none"> The file name or directory name that was specified for the instruction to create is too long. 				S		O030
54015622 hex	SD Memory Card Access Failed	SD Memory Card access failed.	<ul style="list-style-type: none"> The SD Memory Card is damaged. The SD Memory Card slot is broken. 				S		O030
54015623 hex	Load NC Program Capacity Exceeded	Loading failed because an attempt was made to load the NC program over the maximum capacity.	<ul style="list-style-type: none"> An attempt was made to load the NC program over the maximum capacity. 				S		O030
54015624 hex	Number of NC Program Exceeded	Loading failed because an attempt was made to load NC programs over the maximum number of NC programs.	<ul style="list-style-type: none"> A new NC program was loaded while the number of loaded NC programs reaches the maximum. 				S		O030
54015625 hex	Illegal CNC Motor Specification	The CNC motor specified for the Target in-out variable to a CNC instruction is not exist.	<ul style="list-style-type: none"> A CNC motor does not exist for the variable specified for the Target input variable to the instruction. 				S		O030
54015626 hex	Illegal CNC Motor Compensation Table Specification	The CNC motor compensation table specified for the Target input variable to a CNC instruction is not exist.	<ul style="list-style-type: none"> A CNC motor compensation table does not exist for the variable specified for the Target input variable to the instruction. 				S		O030
54015628 hex	Illegal Load NC Program	An error was detected in the loaded NC program.	<ul style="list-style-type: none"> A syntax error was detected in the NC program you made an attempt to load. 				S		O030
54016783 hex	Target Position Positive Software Limit Exceeded	The specified position exceeds the positive software limit.	<ul style="list-style-type: none"> The parameter specified for the Position input variable to the instruction is beyond the positive software limit. The first position is beyond the positive software limit and an instruction that specifies motion in the opposite direction of the software limit was executed. 				S		O030

Event code	Event name	Meaning	Assumed cause	Level					Reference
				Maj	Prt	Min	Obs	Info	
54016784 hex	Target Position Negative Software Limit Exceeded	The specified position exceeds the negative software limit.	<ul style="list-style-type: none"> The parameter specified for the <i>Position</i> input variable to the instruction is beyond the negative software limit. The first position is beyond the negative software limit and an instruction that specifies motion in the opposite direction of the software limit was executed. 				S		O030
54016785 hex	Command Position Overflow/Underflow	Positioning, an instruction in the underflow/overflow direction, or an instruction for which the direction is not specified was executed when there was an underflow/overflow in the command position.	<ul style="list-style-type: none"> One of the following was executed when there was a command position overflow/underflow. <ul style="list-style-type: none"> A positioning instruction A continuous control instruction in the underflow/overflow direction An instruction for which the direction is not specified (syncing) 				S		O030
54016786 hex	Positive Limit Input	An instruction was executed for a motion in the positive direction when the positive limit input was <i>ON</i> .	<ul style="list-style-type: none"> An instruction for a motion in the positive direction was executed when the positive limit input was <i>ON</i>, or an instruction for a motion with no direction specification was executed when the positive limit input was <i>ON</i>. 				S		O030
54016787 hex	Negative Limit Input	An instruction for a motion in the negative direction was executed when the negative limit input was <i>ON</i> .	<ul style="list-style-type: none"> An instruction for a motion in the negative direction was executed when the negative limit input was <i>ON</i>, or an instruction for a motion with no direction specification was executed when the negative limit input was <i>ON</i>. 				S		O030
54017784 hex	Servo Main Circuits OFF	An attempt was made to turn ON the Servo when the main circuit power supply to the Servo Drive was <i>OFF</i> .	<ul style="list-style-type: none"> An attempt was made to turn ON the Servo when the main circuit power supply to the Servo Drive was <i>OFF</i>. 				S		O030

3-1-12 Errors in Slave Terminals

The section provides tables of the errors (events) that can occur in the following Units in OMRON Slave Terminals.

- NX-series EtherCAT Coupler Units
- NX-series Digital I/O Units
- NX-series Analog I/O Units
- NX-series System Units
- NX-series Position Interface Units
- NX-series Communications Interface Units
- NX-series Safety Control Units
- NX-series Load Cell Input Units
- NX-series IO-Link Master Units

NX-series EtherCAT Coupler Units

The section provides a table of the errors (events) that can occur in the following Unit.

NX-ECC□□□

The manual names are given below for the catalog numbers given in the *Reference* column of the event table.

Cat. No.	Manual name
W519	NX-series EtherCAT Coupler Unit User's Manual

Event code	Event name	Meaning	Assumed cause	Level					Reference
				Maj	Prt	Min	Obs	Info	
00210000 hex	Bus Controller Error	An internal bus error occurred.	<ul style="list-style-type: none"> • A Unit failed or an I/O communications error occurred between the Communications Coupler Unit and the NX Unit. 			S			W519
00220000 hex	Non-volatile Memory Hardware Error	An error occurred in non-volatile memory.	<ul style="list-style-type: none"> • Non-volatile memory failure 			S			W519
05010000 hex	ESC Error	An error occurred in the EtherCAT slave communications controller.	<ul style="list-style-type: none"> • An error occurred in the EtherCAT slave communications controller. 			S			W519
05020000 hex	ESC Initialization Error	Initialization of the EtherCAT slave communications controller failed.	<ul style="list-style-type: none"> • An initialization error occurred in the EtherCAT slave communications controller. 			S			W519
05030000 hex	Slave Unit Verification Error	An error occurred in Slave Unit verification.	<ul style="list-style-type: none"> • An error occurred in Slave Unit information. 			S			W519
10420000 hex	Non-volatile Memory Control Parameter Error	An error occurred in the control parameters.	<ul style="list-style-type: none"> • The power supply to the Communications Coupler Unit was turned OFF or Support Software communications were disconnected while writing the Unit operation settings was in progress. 			S			W519
10430000 hex	Memory Corruption Detected	Memory corruption was detected.	<ul style="list-style-type: none"> • Memory corruption was detected. 			S			W519

Event code	Event name	Meaning	Assumed cause	Level					Reference
				Maj	Prt	Min	Obs	Info	
24A00000 hex	Unit Configuration Error, Too Many Units	The number of connected NX Units exceeds the maximum value for the Communications Coupler Unit.	<ul style="list-style-type: none"> More than the maximum number of NX Units is connected to the Communications Coupler Unit. 			S			W519
24A10000 hex	Unit Configuration Error, Unsupported Configuration	An unsupported NX Unit is mounted. Or, the total byte size of all I/O data for the connected NX Units exceeds the predetermined maximum value for the Communications Coupler Unit.	<ul style="list-style-type: none"> An unsupported NX Unit was detected. The total byte size of all I/O data for the connected NX Units exceeds the predetermined maximum value for the Communications Coupler Unit. 			S			W519
35000000 hex	Unit Configuration Information Error	An error occurred in the Unit configuration information in the Communications Coupler Unit.	<ul style="list-style-type: none"> The power supply to the Communications Coupler Unit was turned OFF or Support Software communications were disconnected during a downloading of the Unit configuration information. 			S			W519
35010000 hex	Unit Configuration Verification Error	There is an inconsistency between the Unit configuration information in the Communications Coupler Unit and the Units that are actually connected. Or, the Unit configuration was changed during operation while the Unit configuration information was not set in the Communications Coupler Unit.	<ul style="list-style-type: none"> An NX Unit that is registered in the Unit configuration information is not connected. A connected NX Unit does not agree with the NX Unit that is registered in the Unit configuration information. An NX Unit that is not registered in the Unit configuration information is connected. A mounted Unit is disabled in the NX Unit Mounting Setting for the Unit configuration information. An NX Unit became disconnected during operation. An NX Unit was connected during operation. The serial number of a Unit that is registered in the Unit configuration information does not agree with the serial number of the Unit that is connected. (The Serial Number Check Method is set to <i>Setting = Actual device</i>.) The version of a Unit that is registered in the Unit configuration information is newer than the version of the Unit that is connected. The power supply to an Additional NX Unit Power Supply Unit is not turned ON. 			S			W519
35020000 hex	NX Unit Minor Fault	A minor fault was detected in an NX Unit.	<ul style="list-style-type: none"> A minor fault level error occurred in a Unit where an error was detected. This event is recorded in the event log in the Communications Coupler Unit. 			S			W519

Event code	Event name	Meaning	Assumed cause	Level					Reference
				Maj	Prt	Min	Obs	Info	
35040000 hex	Mailbox Setting Error	An incorrect mailbox setting was detected for the Sync Manager. (AL-Status Code: 0016 hex)	<ul style="list-style-type: none"> An incorrect mailbox setting was detected for the Sync Manager. 			S			W519
35050000 hex	RxPDO Setting Error	An error was detected in the RxPDO settings. (AL-Status Code: 001D hex)	<ul style="list-style-type: none"> An error was detected in the RxPDO settings. 			S			W519
35060000 hex	TxPDO Setting Error	An error was detected in the TxPDO settings. (AL-Status Code: 001E hex)	<ul style="list-style-type: none"> An error was detected in the TxPDO settings. 			S			W519
35070000 hex	PDO WDT Setting Error	An incorrect PDO WDT setting was detected. (AL-Status Code: 001F hex)	<ul style="list-style-type: none"> An incorrect PDO WDT setting was detected. 			S			W519
35080000 hex	SM Event Mode Setting Error	An SM Event Mode that is not supported was set. (AL-Status Code: 0028 hex)	<ul style="list-style-type: none"> An SM Event Mode that is not supported was set. 			S			W519
35090000 hex	TxPDO Mapping Error	An incorrect TxPDO was set. (AL-Status Code: 0024 hex)	<ul style="list-style-type: none"> An incorrect TxPDO was set, e.g., the index, subindex, or size was outside of the allowable range. 			S			W519
350A0000 hex	RxPDO Mapping Error	An incorrect RxPDO was set. (AL-Status Code: 0025 hex)	<ul style="list-style-type: none"> An incorrect RxPDO was set, e.g., the index, subindex, or size was outside of the allowable range. 			S			W519
350B0000 hex	Illegal State Transition Request Received	An incorrect state transition request was received. (AL-Status Code: 0011 hex)	<ul style="list-style-type: none"> An incorrect state transition request was received. 			S			W519
350C0000 hex	Error State Transition Received	An unclear state transition request was received. (AL-Status Code: 0012 hex)	<ul style="list-style-type: none"> An unclear state transition request was received. 			S			W519
350D0000 hex	Synchronization Cycle Setting Error	When DC Mode was confirmed, the cycle time was set to a value that made operation impossible. (AL-Status Code: 0035 hex)	<ul style="list-style-type: none"> When DC Mode was confirmed, the cycle time was set to a value that made operation impossible. 			S			W519
40200000 hex	NX Unit Processing Error	A fatal error occurred in an NX Unit.	<ul style="list-style-type: none"> An error occurred in the software. 			S			W519
84C00000 hex	NX Unit Communications Timeout	An error occurred in I/O data communications with the NX Units.	<ul style="list-style-type: none"> An NX Unit is not mounted properly. An NX Unit has failed. 			S			W519

Event code	Event name	Meaning	Assumed cause	Level					Reference
				Maj	Prt	Min	Obs	Info	
84C10000 hex	NX Unit Initialization Error	Initializing an NX Unit failed.	<ul style="list-style-type: none"> An error occurred in processing the Communications Coupler Unit. An initialization error occurred in an NX Unit. The Enabled Channel Settings for all channels of the Analog Input Unit are set to <i>Disable</i>. The Enabled Channel Settings for all channels of the Analog Output Unit are set to <i>Disable</i>. 			S			W519
85000000 hex	Process Data WDT Error	Process data communications were stopped for more than the specified period of time.	<ul style="list-style-type: none"> The EtherCAT communications cable is disconnected or broken. There is an error in the host controller. 			S			W519
85010000 hex	Synchronization Interruption Error	A synchronization interruption error occurred.	<ul style="list-style-type: none"> The EtherCAT communications cable is disconnected or broken. There is a synchronization setting error in the EtherCAT Coupler Unit. There is a hardware error in the EtherCAT Coupler Unit. 			S			W519
85020000 hex	Synchronization Error	A synchronization error occurred.	<ul style="list-style-type: none"> The EtherCAT communications cable is disconnected or broken. There is a synchronization setting error in the EtherCAT master or EtherCAT Coupler Unit. There is a hardware error in the EtherCAT Coupler Unit. 			S			W519
85030000 hex	Communications Synchronization Error	The number of consecutive communications errors in receiving the synchronization data exceeded the value that is set for the Consecutive Communications Error Detection Count parameter in the Communications Error Settings.	<ul style="list-style-type: none"> Power to the host controller was interrupted during process data communications. The EtherCAT communications cable is disconnected or broken. Noise is entering on an EtherCAT communications cable. 			S			W519
84C50000 hex	NX Unit Startup Error	Starting an NX Unit failed.	<ul style="list-style-type: none"> A startup error occurred in an NX Unit. 			S			W519
35030000 hex	NX Unit Observation	An observation was detected in an NX Unit.	<ul style="list-style-type: none"> An observation level error occurred in a Unit where an error was detected. This event is recorded in the event log in the Communications Coupler Unit. 				S		W519
350E0000 hex	NX Bus Cycle Delay Detected	Exceeding the NX bus cycle was detected.	<ul style="list-style-type: none"> The NX bus cycle was exceeded. 				S		W519

Event code	Event name	Meaning	Assumed cause	Level					Reference
				Maj	Prt	Min	Obs	Info	
80220000 hex	NX Message Communications Error	An error was detected in message communications and the message frame was discarded.	For the NX bus of CPU Units <ul style="list-style-type: none"> The message communications load is high. For Communications Coupler Units <ul style="list-style-type: none"> The message communications load is high. The communications cable is disconnected or broken. This cause does not apply if attached information 2 is 0 (NX bus). Message communications were cutoff in communications. 				S		W519
90400000 hex	Event Log Cleared	The event log was cleared.	<ul style="list-style-type: none"> The event log was cleared by the user. 					S	W519
90420000 hex	Restart Executed	A restart was executed.	<ul style="list-style-type: none"> A restart command was received. 					S	W519
90430000 hex	Memory All Cleared	The Unit settings were cleared.	<ul style="list-style-type: none"> The non-volatile memory in the EtherCAT Coupler Unit was cleared. 					S	W519
94600000 hex (Ver. 1.07 or later)	I/O Check Execution Started	I/O checking was started.	<ul style="list-style-type: none"> I/O checking was started. 					S	W519

NX-series Digital I/O Units

The section provides a table of the errors (events) that can occur in the following Units.

NX-ID□□□□

NX-OC□□□□

NX-OD□□□□

The manual names are given below for the catalog numbers given in the *Reference* column of the event table.

Cat. No.	Manual name
W521	NX-series Digital I/O Unit User's Manual

Event code	Event name	Meaning	Assumed cause	Level					Reference
				Maj	Prt	Min	Obs	Info	
00200000 hex	Non-volatile Memory Hardware Error	An error occurred in non-volatile memory.	<ul style="list-style-type: none"> Non-volatile memory failure 				S		W521

Event code	Event name	Meaning	Assumed cause	Level					Reference
				Maj	Prt	Min	Obs	Info	
10410000 hex	Control Parameter Error in Master	An error occurred in the control parameters that are saved in the master.	<p>For the NX bus of CPU Units</p> <ul style="list-style-type: none"> The power supply to the CPU Unit was turned OFF while writing the Unit operation settings was in progress. Or there is an error in the area of the non-volatile memory in the CPU Unit in which the Unit operation settings for the relevant NX Unit are saved. <p>For Communications Coupler Units</p> <ul style="list-style-type: none"> The power supply to the Communications Coupler Unit was turned OFF while writing the Unit operation settings was in progress. Or there is an error in the area of the non-volatile memory in the Communications Coupler Unit in which the Unit operation settings for the relevant NX Unit are saved. 			S			W521
80200000 hex	NX Unit I/O Communications Error	An I/O communications error occurred in an NX Unit.	<p>For the NX bus of CPU Units</p> <ul style="list-style-type: none"> An error that prevents normal NX bus communications occurred in a CPU Unit. An NX Unit is not mounted properly. The power cable for the Unit power supply is disconnected, or the wiring from the Unit power supply to the NX Units is incorrect. The power cable for the Unit power supply is broken. The voltage of the Unit power supply is outside the specified range, or the capacity of the Unit power supply is insufficient. There is a hardware error in an NX Unit. <p>For Communications Coupler Units</p> <ul style="list-style-type: none"> An error that prevents normal NX bus communications occurred in a Communications Coupler Unit. The NX Unit is not mounted properly. The power cable for the Unit power supply is disconnected. Or, the wiring from the Unit power supply to the NX Units is incorrect. The power cable for the Unit power supply is broken. The voltage of the Unit power supply is outside the specified range. Or, the capacity of the Unit power supply is insufficient. There is a hardware error in the NX Unit. 			S			W521

Event code	Event name	Meaning	Assumed cause	Level					Reference
				Maj	Prt	Min	Obs	Info	
80210000 hex	NX Unit Output Synchronization Error	An output synchronization error occurred in the NX Unit.	<p>For the NX bus of CPU Units</p> <ul style="list-style-type: none"> I/O refreshing on the NX bus is not performed normally due to an error in the CPU Unit. <p>For Communications Coupler Units</p> <ul style="list-style-type: none"> The communications cable connected to the Communications Coupler Unit is broken or the connection is faulty. The communications cable is affected by noise. 			S			W521
80240000 hex	NX Unit Clock Not Synchronized Error	A time information error occurred in an NX Unit.	<p>For the NX bus of CPU Units</p> <ul style="list-style-type: none"> There is a hardware error in an NX Unit. There is a hardware error in a CPU Unit. <p>For Communications Coupler Units</p> <ul style="list-style-type: none"> There is a hardware error in an NX Unit. There is a hardware error in an EtherCAT Coupler Unit. 			S			W521
70010000 hex (Ver. 1.06)	Previous Time Specified	A previous time was specified for output refreshing with a specified time stamp.	<p>For the NX bus of CPU Units</p> <ul style="list-style-type: none"> A past time is specified due to an error in the user program. A Task Period Exceeded error occurred in a CPU Unit. <p>For Communications Coupler Units</p> <ul style="list-style-type: none"> A past time is specified due to an error in the user program. A Task Period Exceeded error occurred in a CPU Unit. The arrival of I/O data at an NX Unit was delayed due to a Communications Synchronization Error or other communications error. 				S		W521
90400000 hex	Event Log Cleared	The event log was cleared.	<ul style="list-style-type: none"> The event log was cleared by the user. 					S	W521

NX-series Analog I/O Units

The section provides a table of the errors (events) that can occur in the following Units.

NX-AD□□□□

NX-DA□□□□

NX-TS□□□□

NX-HB□□□□

The manual names are given below for the catalog numbers given in the *Reference* column of the event table.

Cat. No.	Manual name
W522	NX-series Analog I/O Units User's Manual for Analog Input Units and Analog Output Units
W566*1	NX-series Analog I/O Units User's Manual for Temperature Input Units and Heater Burn-out Detection Units

*1 Temperature Input Units are introduced in Cat. No. W522 before Cat. No. W566 is released.

● Analog Input Units and Analog Output Units (NX-AD□□□□, NX-DA□□□□)

Event code	Event name	Meaning	Assumed cause	Level					Reference
				Maj	Prt	Min	Obs	Info	
00200000 hex	Non-volatile Memory Hardware Error	An error occurred in non-volatile memory.	<ul style="list-style-type: none"> Non-volatile memory failure 			S			W522
10400000 hex	Analog Unit Calibration Parameter Error	An error occurred for the calibration data in the Analog Unit.	<ul style="list-style-type: none"> The power supply to the Analog Unit was turned OFF or Support Software communications were disconnected while writing the calibration values to the Analog Unit. 			S			W522
10410000 hex	Control Parameter Error in Master	An error occurred in the control parameters that are saved in the master.	<p>For the NX bus of CPU Units</p> <ul style="list-style-type: none"> The power supply to the CPU Unit was turned OFF while writing the Unit operation settings was in progress. Or there is an error in the area of the non-volatile memory in the CPU Unit in which the Unit operation settings for the relevant NX Unit are saved. <p>For Communications Coupler Units</p> <ul style="list-style-type: none"> The power supply to the Communications Coupler Unit was turned OFF while writing the Unit operation settings was in progress. Or there is an error in the area of the non-volatile memory in the Communications Coupler Unit in which the Unit operation settings for the relevant NX Unit are saved. 			S			W522
14C00000 hex	Unit Calibration Value Parity Error	An error occurred in the user calibration data in the NX Unit.	<ul style="list-style-type: none"> An error was detected in the calibration data. 			S			W522

Event code	Event name	Meaning	Assumed cause	Level					Reference
				Maj	Prt	Min	Obs	Info	
65030000 hex	Unit I/O Disconnection Detected for Channel 1	A disconnected input was detected for channel 1.	<ul style="list-style-type: none"> Input wiring is broken. Input wiring is disconnected. 			S	U		W522
65040000 hex	Unit I/O Disconnection Detected for Channel 2	A disconnected input was detected for channel 2.	<ul style="list-style-type: none"> Input wiring is broken. Input wiring is disconnected. 			S	U		W522
65050000 hex	Unit I/O Disconnection Detected for Channel 3	A disconnected input was detected for channel 3.	<ul style="list-style-type: none"> Input wiring is broken. Input wiring is disconnected. 			S	U		W522
65060000 hex	Unit I/O Disconnection Detected for Channel 4	A disconnected input was detected for channel 4.	<ul style="list-style-type: none"> Input wiring is broken. Input wiring is disconnected. 			S	U		W522
65070000 hex	Unit I/O Disconnection Detected for Channel 5	A disconnected input was detected for channel 5.	<ul style="list-style-type: none"> Input wiring is broken. Input wiring is disconnected. 			S	U		W522
65080000 hex	Unit I/O Disconnection Detected for Channel 6	A disconnected input was detected for channel 6.	<ul style="list-style-type: none"> Input wiring is broken. Input wiring is disconnected. 			S	U		W522
65090000 hex	Unit I/O Disconnection Detected for Channel 7	A disconnected input was detected for channel 7.	<ul style="list-style-type: none"> Input wiring is broken. Input wiring is disconnected. 			S	U		W522
650A0000 hex	Unit I/O Disconnection Detected for Channel 8	A disconnected input was detected for channel 8.	<ul style="list-style-type: none"> Input wiring is broken. Input wiring is disconnected. 			S	U		W522

Event code	Event name	Meaning	Assumed cause	Level					Reference
				Maj	Prt	Min	Obs	Info	
80200000 hex	NX Unit I/O Communications Error	An I/O communications error occurred in an NX Unit.	<p>For the NX bus of CPU Units</p> <ul style="list-style-type: none"> An error that prevents normal NX bus communications occurred in a CPU Unit. An NX Unit is not mounted properly. The power cable for the Unit power supply is disconnected, or the wiring from the Unit power supply to the NX Units is incorrect. The power cable for the Unit power supply is broken. The voltage of the Unit power supply is outside the specified range, or the capacity of the Unit power supply is insufficient. There is a hardware error in an NX Unit. <p>For Communications Coupler Units</p> <ul style="list-style-type: none"> An error that prevents normal NX bus communications occurred in a Communications Coupler Unit. The NX Unit is not mounted properly. The power cable for the Unit power supply is disconnected. Or, the wiring from the Unit power supply to the NX Units is incorrect. The power cable for the Unit power supply is broken. The voltage of the Unit power supply is outside the specified range. Or, the capacity of the Unit power supply is insufficient. There is a hardware error in the NX Unit. 			S			W522
80210000 hex	NX Unit Output Synchronization Error	An output synchronization error occurred in the NX Unit.	<p>For the NX bus of CPU Units</p> <ul style="list-style-type: none"> I/O refreshing on the NX bus is not performed normally due to an error in the CPU Unit. <p>For Communications Coupler Units</p> <ul style="list-style-type: none"> The communications cable connected to the Communications Coupler Unit is broken or the connection is faulty. The communications cable is affected by noise. 			S			W522

Event code	Event name	Meaning	Assumed cause	Level					Reference
				Maj	Prt	Min	Obs	Info	
80240000 hex	NX Unit Clock Not Synchronized Error	A time information error occurred in an NX Unit.	<p>For the NX bus of CPU Units</p> <ul style="list-style-type: none"> • There is a hardware error in an NX Unit. • There is a hardware error in a CPU Unit. <p>For Communications Coupler Units</p> <ul style="list-style-type: none"> • There is a hardware error in an NX Unit. • There is a hardware error in an EtherCAT Coupler Unit. 			S			W522
64F00000 hex	Unit Over Range for Channel 1	The analog input data for input channel 1 exceeded the upper limit of the input range. Or, the analog output data for output channel 1 exceeded the upper limit of the output range.	<ul style="list-style-type: none"> • The analog input data exceeded the upper limit of the input range. Or, the analog output data exceeded the upper limit of the output range. 			U	S		W522
64F10000 hex	Unit Over Range for Channel 2	The analog input data for input channel 2 exceeded the upper limit of the input range. Or, the analog output data for output channel 2 exceeded the upper limit of the output range.	<ul style="list-style-type: none"> • The analog input data exceeded the upper limit of the input range. Or, the analog output data exceeded the upper limit of the output range. 			U	S		W522
64F20000 hex	Unit Over Range for Channel 3	The analog input data for input channel 3 exceeded the upper limit of the input range. Or, the analog output data for output channel 3 exceeded the upper limit of the output range.	<ul style="list-style-type: none"> • The analog input data exceeded the upper limit of the input range. Or, the analog output data exceeded the upper limit of the output range. 			U	S		W522
64F30000 hex	Unit Over Range for Channel 4	The analog input data for input channel 4 exceeded the upper limit of the input range. Or, the analog output data for output channel 4 exceeded the upper limit of the output range.	<ul style="list-style-type: none"> • The analog input data exceeded the upper limit of the input range. Or, the analog output data exceeded the upper limit of the output range. 			U	S		W522
64F40000 hex	Unit Over Range for Channel 5	The analog input data for input channel 5 exceeded the upper limit of the input range. Or, the analog output data for output channel 5 exceeded the upper limit of the output range.	<ul style="list-style-type: none"> • The analog input data exceeded the upper limit of the input range. Or, the analog output data exceeded the upper limit of the output range. 			U	S		W522

Event code	Event name	Meaning	Assumed cause	Level					Reference
				Maj	Prt	Min	Obs	Info	
64F50000 hex	Unit Over Range for Channel 6	The analog input data for input channel 6 exceeded the upper limit of the input range. Or, the analog output data for output channel 6 exceeded the upper limit of the output range.	<ul style="list-style-type: none"> The analog input data exceeded the upper limit of the input range. Or, the analog output data exceeded the upper limit of the output range. 			U	S		W522
64F60000 hex	Unit Over Range for Channel 7	The analog input data for input channel 7 exceeded the upper limit of the input range. Or, the analog output data for output channel 7 exceeded the upper limit of the output range.	<ul style="list-style-type: none"> The analog input data exceeded the upper limit of the input range. Or, the analog output data exceeded the upper limit of the output range. 			U	S		W522
64F70000 hex	Unit Over Range for Channel 8	The analog input data for input channel 8 exceeded the upper limit of the input range. Or, the analog output data for output channel 8 exceeded the upper limit of the output range.	<ul style="list-style-type: none"> The analog input data exceeded the upper limit of the input range. Or, the analog output data exceeded the upper limit of the output range. 			U	S		W522
64F80000 hex	Unit Under Range for Channel 1	The analog input data for input channel 1 went below the lower limit of the input range. Or, the analog output data for output channel 1 went below the lower limit of the output range.	<ul style="list-style-type: none"> The analog input data went below the lower limit of the input range. Or, the analog output data went below the lower limit of the output range. 			U	S		W522
64F90000 hex	Unit Under Range for Channel 2	The analog input data for input channel 2 went below the lower limit of the input range. Or, the analog output data for output channel 2 went below the lower limit of the output range.	<ul style="list-style-type: none"> The analog input data went below the lower limit of the input range. Or, the analog output data went below the lower limit of the output range. 			U	S		W522
64FA0000 hex	Unit Under Range for Channel 3	The analog input data for input channel 3 went below the lower limit of the input range. Or, the analog output data for output channel 3 went below the lower limit of the output range.	<ul style="list-style-type: none"> The analog input data went below the lower limit of the input range. Or, the analog output data went below the lower limit of the output range. 			U	S		W522

Event code	Event name	Meaning	Assumed cause	Level					Reference
				Maj	Prt	Min	Obs	Info	
64FB0000 hex	Unit Under Range for Channel 4	The analog input data for input channel 4 went below the lower limit of the input range. Or, the analog output data for output channel 4 went below the lower limit of the output range.	<ul style="list-style-type: none"> The analog input data went below the lower limit of the input range. Or, the analog output data went below the lower limit of the output range. 			U	S		W522
64FC0000 hex	Unit Under Range for Channel 5	The analog input data for input channel 5 went below the lower limit of the input range. Or, the analog output data for output channel 5 went below the lower limit of the output range.	<ul style="list-style-type: none"> The analog input data went below the lower limit of the input range. Or, the analog output data went below the lower limit of the output range. 			U	S		W522
64FD0000 hex	Unit Under Range for Channel 6	The analog input data for input channel 6 went below the lower limit of the input range. Or, the analog output data for output channel 6 went below the lower limit of the output range.	<ul style="list-style-type: none"> The analog input data went below the lower limit of the input range. Or, the analog output data went below the lower limit of the output range. 			U	S		W522
64FE0000 hex	Unit Under Range for Channel 7	The analog input data for input channel 7 went below the lower limit of the input range. Or, the analog output data for output channel 7 went below the lower limit of the output range.	<ul style="list-style-type: none"> The analog input data went below the lower limit of the input range. Or, the analog output data went below the lower limit of the output range. 			U	S		W522
64FF0000 hex	Unit Under Range for Channel 8	The analog input data for input channel 8 went below the lower limit of the input range. Or, the analog output data for output channel 8 went below the lower limit of the output range.	<ul style="list-style-type: none"> The analog input data went below the lower limit of the input range. Or, the analog output data went below the lower limit of the output range. 			U	S		W522
90400000 hex	Event Log Cleared	The event log was cleared.	<ul style="list-style-type: none"> The event log was cleared by the user. 					S	W522

● Temperature Input Units (NX-TS□□□□)

Event code	Event name	Meaning	Assumed cause	Level					Reference
				Maj	Prt	Min	Obs	Info	
00200000 hex	Non-volatile Memory Hardware Error	An error occurred in non-volatile memory.	<ul style="list-style-type: none"> Non-volatile memory failure. 			S			W566 (W522)
05100000 hex	A/D Converter Error	An error occurred in the A/D converter	<ul style="list-style-type: none"> Noise A/D converter failure 			S			W566 (W522)

Event code	Event name	Meaning	Assumed cause	Level					Reference
				Maj	Prt	Min	Obs	Info	
05110000 hex	Cold Junction Sensor Error	The temperature cannot be converted because the cold junction sensor is disconnected.	<ul style="list-style-type: none"> There is a faulty connection to the cold junction sensor. The cold junction sensor failed. 			S	U		W566 (W522)
10410000 hex	Control Parameter Error in Master	An error occurred in the control parameters that are saved in the master.	<p>For the NX bus of CPU Units</p> <ul style="list-style-type: none"> The power supply to the CPU Unit was turned OFF while writing the Unit operation settings was in progress. Or there is an error in the area of the non-volatile memory in the CPU Unit in which the Unit operation settings for the relevant NX Unit are saved. <p>For Communications Coupler Units</p> <ul style="list-style-type: none"> The power supply to the Communications Coupler Unit was turned OFF while writing the Unit operation settings was in progress. Or there is an error in the area of the non-volatile memory in the Communications Coupler Unit in which the Unit operation settings for the relevant NX Unit are saved. 			S			W566 (W522)
40200000 hex	NX Unit Processing Error	A fatal error occurred in an NX Unit.	<ul style="list-style-type: none"> An error occurred in the software. 			S			W566 (W522)
65100000 hex	Sensor Disconnected Error	A disconnected temperature sensor was detected.	<ul style="list-style-type: none"> The temperature sensor is damaged or the wires are broken. An unused channel is not disabled. 			S	U		W566 (W522)

Event code	Event name	Meaning	Assumed cause	Level					Reference
				Maj	Prt	Min	Obs	Info	
80200000 hex	NX Unit I/O Communications Error	An I/O communications error occurred in an NX Unit.	<p>For the NX bus of CPU Units</p> <ul style="list-style-type: none"> An error that prevents normal NX bus communications occurred in a CPU Unit. An NX Unit is not mounted properly. The power cable for the Unit power supply is disconnected, or the wiring from the Unit power supply to the NX Units is incorrect. The power cable for the Unit power supply is broken. The voltage of the Unit power supply is outside the specified range, or the capacity of the Unit power supply is insufficient. There is a hardware error in an NX Unit. <p>For Communications Coupler Units</p> <ul style="list-style-type: none"> An error that prevents normal NX bus communications occurred in a Communications Coupler Unit. The NX Unit is not mounted properly. The power cable for the Unit power supply is disconnected. Or, the wiring from the Unit power supply to the NX Units is incorrect. The power cable for the Unit power supply is broken. The voltage of the Unit power supply is outside the specified range. Or, the capacity of the Unit power supply is insufficient. There is a hardware error in the NX Unit. 			S			W566 (W522)
80240000 hex	NX Unit Clock Not Synchronized Error	A time information error occurred in an NX Unit.	<p>For the NX bus of CPU Units</p> <ul style="list-style-type: none"> There is a hardware error in an NX Unit. There is a hardware error in a CPU Unit. <p>For Communications Coupler Units</p> <ul style="list-style-type: none"> There is a hardware error in an NX Unit. There is a hardware error in an EtherCAT Coupler Unit. 			S			W566 (W522)

Event code	Event name	Meaning	Assumed cause	Level					Reference
				Maj	Prt	Min	Obs	Info	
65110000 hex	Process Value Over Range	The process temperature exceeded the upper limit of temperature conversion range.	<ul style="list-style-type: none"> The sensor is disconnected. The sensor or the compensating cables are not wired correctly. The sensor and the input type setting do not agree. The range of the input type is too narrow for the temperatures that need to be measured. An unused channel is not disabled. 			U	S		W566 (W522)
65120000 hex	Process Value Under Range	The process temperature went below the lower limit of temperature conversion range.	<ul style="list-style-type: none"> The sensor or the compensating cables are not wired correctly. The sensor and the input type setting do not agree. The range of the input type is too narrow for the temperatures that need to be measured. 			U	S		W566 (W522)
80220000 hex	NX Message Communications Error	An error was detected in message communications and the message frame was discarded.	<p>For the NX bus of CPU Units</p> <ul style="list-style-type: none"> The message communications load is high. <p>For Communications Coupler Units</p> <ul style="list-style-type: none"> The message communications load is high. The communications cable is disconnected or broken. Message communications were cutoff in communications. 				S		W566 (W522)
90400000 hex	Event Log Cleared	The event log was cleared.	<ul style="list-style-type: none"> The event log was cleared by the user. 					S	W566 (W522)

● Heater Burnout Detection Units (NX-HB□□□□)

Event code	Event name	Meaning	Assumed cause	Level					Reference
				Maj	Prt	Min	Obs	Info	
00200000 hex	Non-volatile Memory Hardware Error	An error occurred in non-volatile memory.	<ul style="list-style-type: none"> Non-volatile memory failure. 			S			W566
05100000 hex	A/D Converter Error	An error occurred in the A/D converter	<ul style="list-style-type: none"> Noise A/D converter failure 			S			W566

Event code	Event name	Meaning	Assumed cause	Level					Reference
				Maj	Prt	Min	Obs	Info	
10410000 hex	Control Parameter Error in Master	An error occurred in the control parameters that are saved in the master.	<p>For the NX bus of CPU Units</p> <ul style="list-style-type: none"> The power supply to the CPU Unit was turned OFF while writing the Unit operation settings was in progress. Or there is an error in the area of the non-volatile memory in the CPU Unit in which the Unit operation settings for the relevant NX Unit are saved. <p>For Communications Coupler Units</p> <ul style="list-style-type: none"> The power supply to the Communications Coupler Unit was turned OFF while writing the Unit operation settings was in progress. Or there is an error in the area of the non-volatile memory in the Communications Coupler Unit in which the Unit operation settings for the relevant NX Unit are saved. 			S			W566
40200000 hex	NX Unit Processing Error	A fatal error occurred in an NX Unit.	<ul style="list-style-type: none"> An error occurred in the software. 			S			W566
652C0000 hex	Heater Burnout Detected	A heater burnout was detected.	<ul style="list-style-type: none"> A heater was burned out or damaged. The setting of the Heater Burnout Detection Current is too high. A CT input that is not used is allocated to a control output in the CT Allocation setting. 			S	U		W566
652D0000 hex	SSR Failure Detected	An SSR failure was detected.	<ul style="list-style-type: none"> The SSR was short-circuited or damaged. The setting of the SSR Failure Detection Current is too small. A CT input that is not used is allocated to a control output in the CT Allocation setting. 			S	U		W566

Event code	Event name	Meaning	Assumed cause	Level					Reference
				Maj	Prt	Min	Obs	Info	
80200000 hex	NX Unit I/O Communications Error	An I/O communications error occurred in an NX Unit.	<p>For the NX bus of CPU Units</p> <ul style="list-style-type: none"> An error that prevents normal NX bus communications occurred in a CPU Unit. An NX Unit is not mounted properly. The power cable for the Unit power supply is disconnected, or the wiring from the Unit power supply to the NX Units is incorrect. The power cable for the Unit power supply is broken. The voltage of the Unit power supply is outside the specified range, or the capacity of the Unit power supply is insufficient. There is a hardware error in an NX Unit. <p>For Communications Coupler Units</p> <ul style="list-style-type: none"> An error that prevents normal NX bus communications occurred in a Communications Coupler Unit. The NX Unit is not mounted properly. The power cable for the Unit power supply is disconnected. Or, the wiring from the Unit power supply to the NX Units is incorrect. The power cable for the Unit power supply is broken. The voltage of the Unit power supply is outside the specified range. Or, the capacity of the Unit power supply is insufficient. There is a hardware error in the NX Unit. 			S			W566
80240000 hex	NX Unit Clock Not Synchronized Error	A time information error occurred in an NX Unit.	<p>For the NX bus of CPU Units</p> <ul style="list-style-type: none"> There is a hardware error in an NX Unit. There is a hardware error in a CPU Unit. <p>For Communications Coupler Units</p> <ul style="list-style-type: none"> There is a hardware error in an NX Unit. There is a hardware error in an EtherCAT Coupler Unit. 			S			W566

Event code	Event name	Meaning	Assumed cause	Level					Reference
				Maj	Prt	Min	Obs	Info	
80220000 hex	NX Message Communications Error	An error was detected in message communications and the message frame was discarded.	For the NX bus of CPU Units <ul style="list-style-type: none"> The message communications load is high. For Communications Coupler Units <ul style="list-style-type: none"> The message communications load is high. The communications cable is disconnected or broken. Message communications were cutoff in communications. 				S		W566
90400000 hex	Event Log Cleared	The event log was cleared.	<ul style="list-style-type: none"> The event log was cleared by the user. 					S	W566

NX-series System Units

The section provides a table of the errors (events) that can occur in the following Units.

NX-PD1□□□

NX-PF0□□□

NX-PC0□□□

NX-TBX01

The manual names are given below for the catalog numbers given in the *Reference* column of the event table.

Cat. No.	Manual name
W523	NX-series System Unit User's Manual

Event code	Event name	Meaning	Assumed cause	Level					Reference
				Maj	Prt	Min	Obs	Info	
00200000 hex	Non-volatile Memory Hardware Error	An error occurred in non-volatile memory.	<ul style="list-style-type: none"> Non-volatile memory failure 			S			W523
90400000 hex	Event Log Cleared	The event log was cleared.	<ul style="list-style-type: none"> The event log was cleared by the user. 					S	W523

NX-series Position Interface Units

The section provides a table of the errors (events) that can occur in the following Units.

NX-EC0□□□

NX-ECS□□□

NX-PG0□□□

The manual names are given below for the catalog numbers given in the *Reference* column of the event table.

Cat. No.	Manual name
W524	NX-series Position Interface Units User's Manual

Event code	Event name	Meaning	Assumed cause	Level					Reference
				Maj	Prt	Min	Obs	Info	
00200000 hex	Non-volatile Memory Hardware Error	An error occurred in non-volatile memory.	<ul style="list-style-type: none"> Non-volatile memory failure 			S			W524
10410000 hex	Control Parameter Error in Master	An error occurred in the control parameters that are saved in the master.	<p>For the NX bus of CPU Units</p> <ul style="list-style-type: none"> The power supply to the CPU Unit was turned OFF while writing the Unit operation settings was in progress. Or there is an error in the area of the non-volatile memory in the CPU Unit in which the Unit operation settings for the relevant NX Unit are saved. <p>For Communications Coupler Units</p> <ul style="list-style-type: none"> The power supply to the Communications Coupler Unit was turned OFF while writing the Unit operation settings was in progress. Or there is an error in the area of the non-volatile memory in the Communications Coupler Unit in which the Unit operation settings for the relevant NX Unit are saved. 			S			W524
35100000 hex	External Input Setting Error	A setting for an external input is not correct.	<ul style="list-style-type: none"> The same function (other than a general-purpose input) is assigned to more than one of the external inputs (I0 to I2). 			S			W524
35110000 hex	SSI Data Setting Error	There is an error in the SSI data settings.	<ul style="list-style-type: none"> The sum of the values set for the Valid Data Length and the Leading Bits parameters exceeds 32. The sum of the values set for the Multi-turn Data Length, Single-turn Data Length, and the Status Data Length parameters exceeds 32. The sum of the value set for the start bit position and the data length of the SSI data exceeds the value set for the Valid Data Length parameter. The value set for the Encoder Resolution parameter exceeds the range expressed by the data length set for the Single-turn Data Length parameter. 			S			W524
40200000 hex	NX Unit Processing Error	A fatal error occurred in an NX Unit.	<ul style="list-style-type: none"> An error occurred in the software. 			S			W524
743D0000 hex	Incorrect Synchronization Command	Updating the target position data in the synchronization refresh failed consecutively for more than the specified number of times.	<ul style="list-style-type: none"> The communications cable that connects the Communications Coupler Unit is disconnected or a connection is faulty. Noise 			S	U		W524

Event code	Event name	Meaning	Assumed cause	Level					Reference
				Maj	Prt	Min	Obs	Info	
743E0000 hex	Illegal Following Error	The difference between the command position and actual position exceeds the range expressed by 29 bits.	<ul style="list-style-type: none"> A command that exceeded the maximum velocity (for a model that allows maximum velocity setting, the set value applies to this maximum velocity) was output continuously, so the following error for the actual output, which is restricted by the maximum velocity, has increased. A command velocity that does not correspond to the command position was specified when a velocity-continuous pulse output was used, so the number of pulses that were actually output for the updated command position has increased. 			S			W524
743F0000 hex	Illegal State Transition	The EtherCAT master or EtherCAT Coupler Unit executed a command to change the communications status when the Pulse Output Unit is in the Operation Enabled status.	<ul style="list-style-type: none"> A communications command to change the current communications status was received from the communications master while the Unit is in the Operation Enabled status. 			S			W524

Event code	Event name	Meaning	Assumed cause	Level					Reference
				Maj	Prt	Min	Obs	Info	
80200000 hex	NX Unit I/O Communications Error	An I/O communications error occurred in an NX Unit.	<p>For the NX bus of CPU Units</p> <ul style="list-style-type: none"> An error that prevents normal NX bus communications occurred in a CPU Unit. An NX Unit is not mounted properly. The power cable for the Unit power supply is disconnected, or the wiring from the Unit power supply to the NX Units is incorrect. The power cable for the Unit power supply is broken. The voltage of the Unit power supply is outside the specified range, or the capacity of the Unit power supply is insufficient. There is a hardware error in an NX Unit. <p>For Communications Coupler Units</p> <ul style="list-style-type: none"> An error that prevents normal NX bus communications occurred in a Communications Coupler Unit. The NX Unit is not mounted properly. The power cable for the Unit power supply is disconnected. Or, the wiring from the Unit power supply to the NX Units is incorrect. The power cable for the Unit power supply is broken. The voltage of the Unit power supply is outside the specified range. Or, the capacity of the Unit power supply is insufficient. There is a hardware error in the NX Unit. 			S			W524
80210000 hex	NX Unit Output Synchronization Error	An output synchronization error occurred in the NX Unit.	<p>For the NX bus of CPU Units</p> <ul style="list-style-type: none"> I/O refreshing on the NX bus is not performed normally due to an error in the CPU Unit. <p>For Communications Coupler Units</p> <ul style="list-style-type: none"> The communications cable connected to the Communications Coupler Unit is broken or the connection is faulty. The communications cable is affected by noise. 			S			W524

Event code	Event name	Meaning	Assumed cause	Level					Reference
				Maj	Prt	Min	Obs	Info	
80240000 hex	NX Unit Clock Not Synchronized Error	A time information error occurred in an NX Unit.	<p>For the NX bus of CPU Units</p> <ul style="list-style-type: none"> • There is a hardware error in an NX Unit. • There is a hardware error in a CPU Unit. <p>For Communications Coupler Units</p> <ul style="list-style-type: none"> • There is a hardware error in an NX Unit. • There is a hardware error in an EtherCAT Coupler Unit. 			S			W524
80220000 hex	NX Message Communications Error	An error was detected in message communications and the message frame was discarded.	<p>For the NX bus of CPU Units</p> <ul style="list-style-type: none"> • The message communications load is high. <p>For Communications Coupler Units</p> <ul style="list-style-type: none"> • The message communications load is high. • The communications cable is disconnected or broken. • Message communications were cutoff in communications. 				S		W524
84D00000 hex	SSI Communications Error	An error occurred in SSI communications.	<ul style="list-style-type: none"> • The SSI data settings do not agree with the SSI communications settings in the connected device. • The wiring between the NX Unit and the connected device is not correct or disconnected. • Noise 			U	S		W524
90400000 hex	Event Log Cleared	The event log was cleared.	<ul style="list-style-type: none"> • The event log was cleared by the user. 					S	Same as above.

NX-series Communications Interface Units

The section provides a table of the errors (events) that can occur in the following Units.

NX-CIF□□□

The manual names are given below for the catalog numbers given in the *Reference* column of the event tables.

Cat. No.	Manual name
W540	NX-series Communications Interface Units User's Manual

Event code	Event name	Meaning	Assumed cause	Level					Reference
				Maj	Prt	Min	Obs	Info	
00200000 hex	Non-volatile Memory Hardware Error	An error occurred in non-volatile memory.	<ul style="list-style-type: none"> Non-volatile memory failure 			S			W540
10410000 hex	Control Parameter Error in Master	An error occurred in the control parameters that are saved in the master.	<p>For the NX bus of CPU Units</p> <ul style="list-style-type: none"> The power supply to the CPU Unit was turned OFF while writing the Unit operation settings was in progress. Or there is an error in the area of the non-volatile memory in the CPU Unit in which the Unit operation settings for the relevant NX Unit are saved. <p>For Communications Coupler Units</p> <ul style="list-style-type: none"> The power supply to the Communications Coupler Unit was turned OFF while writing the Unit operation settings was in progress. Or there is an error in the area of the non-volatile memory in the Communications Coupler Unit in which the Unit operation settings for the relevant NX Unit are saved. 			S			W540
40200000 hex	NX Unit Processing Error	A fatal error occurred in an NX Unit.	<ul style="list-style-type: none"> An error occurred in the software. 			S			W540

Event code	Event name	Meaning	Assumed cause	Level					Reference
				Maj	Prt	Min	Obs	Info	
80200000 hex	NX Unit I/O Communications Error	An I/O communications error occurred in an NX Unit.	<p>For the NX bus of CPU Units</p> <ul style="list-style-type: none"> An error that prevents normal NX bus communications occurred in a CPU Unit. An NX Unit is not mounted properly. The power cable for the Unit power supply is disconnected, or the wiring from the Unit power supply to the NX Units is incorrect. The power cable for the Unit power supply is broken. The voltage of the Unit power supply is outside the specified range, or the capacity of the Unit power supply is insufficient. There is a hardware error in an NX Unit. <p>For Communications Coupler Units</p> <ul style="list-style-type: none"> An error that prevents normal NX bus communications occurred in a Communications Coupler Unit. An NX Unit is not mounted properly. The power cable for the Unit power supply is disconnected. Or, the wiring from the Unit power supply to the NX Units is incorrect. The power cable for the Unit power supply is broken. The voltage of the Unit power supply is outside the specified range. Or, the capacity of the Unit power supply is insufficient. There is a hardware error in the NX Unit. 			S			W540
80240000 hex	NX Unit Clock Not Synchronized Error	A time information error occurred in an NX Unit.	<p>For the NX bus of CPU Units</p> <ul style="list-style-type: none"> There is a hardware error in an NX Unit. There is a hardware error in a CPU Unit. <p>For Communications Coupler Units</p> <ul style="list-style-type: none"> There is a hardware error in an NX Unit. There is a hardware error in an EtherCAT Coupler Unit. 			S			W540
85400000 hex	Data Discarded Due to Full Internal Buffer	The internal buffer is full. The input data is discarded.	<ul style="list-style-type: none"> If the internal buffer for received data is full, the Controller cannot read the received data. If the internal buffer for transmission data is full, the transmission data was too large or there are too many send requests. 			S	U		W540

Event code	Event name	Meaning	Assumed cause	Level					Reference
				Maj	Prt	Min	Obs	Info	
80220000 hex	NX Message Communications Error	An error was detected in message communications and the message frame was discarded.	For the NX bus of CPU Units <ul style="list-style-type: none"> The message communications load is high. For Communications Coupler Units <ul style="list-style-type: none"> The message communications load is high. The communications cable is disconnected or broken. Message communications were cutoff in communications. 				S		W540
85410000 hex	Parity Error	A parity error occurred.	<ul style="list-style-type: none"> The communications settings and baud rate setting do not agree with those of the remote device. Noise 			U	S		W540
85420000 hex	Framing Error	A framing error occurred.	<ul style="list-style-type: none"> The communications settings and baud rate setting do not agree with those of the remote device. Noise 			U	S		W540
85430000 hex	Overrun Error	An overrun error occurred.	<ul style="list-style-type: none"> The next data was received during processing of received data because the baud rate is too high. 			U	S		W540
90400000 hex	Event Log Cleared	The event log was cleared.	<ul style="list-style-type: none"> The event log was cleared by the user. 					S	W540

NX-series Safety Control Units

The section provides tables of the errors (events) that can occur in the following Units.

NX-SL□□□□

NX-SI□□□□

NX-SO□□□□

The manual names are given below for the catalog numbers given in the *Reference* column of the event table.

Cat. No.	Manual name
Z930	NX-series Safety Control Unit User's Manual

● Safety CPU Units

Event code	Event name	Meaning	Assumed cause	Level					Reference
				Maj	Prt	Min	Obs	Info	
05200000 hex	System Error	A hardware error was detected during self-diagnosis of the hardware.	<ul style="list-style-type: none"> Hardware has failed. A memory error occurred due to a transient cause, such as a software error or excessive noise. 			S			Z930
10500000 hex	NX Bus Communications Settings Read Error	There is an error in the NX bus communications settings that are saved in non-volatile memory.	<ul style="list-style-type: none"> A hardware failure occurred in the non-volatile memory. Power was turned OFF while saving data to the non-volatile memory. 			S			Z930
10510000 hex	Safety Application Data Read Error	There is an error in the safety application data that is saved in non-volatile memory.	<ul style="list-style-type: none"> A hardware failure occurred in the non-volatile memory. Power was turned OFF while saving data to the non-volatile memory. 			S			Z930
10520000 hex	NX Bus Communications Settings and Safety Application Data Mismatch	There is an error in the safety application data that is saved in non-volatile memory.	<ul style="list-style-type: none"> The NX bus communications settings that were transferred to the Safety CPU Unit do not match the safety application data. 			S			Z930
10530000 hex	Non-volatile Memory Access Error	Reading/writing non-volatile memory failed.	Non-volatile memory failed.			S			Z930
35200000 hex	Safety Process Data Communications Not Established Error	Safety process data communications was not established with one or more safety slaves.	<ul style="list-style-type: none"> The communications settings for safety process data are not correct, the safety slave is not in the correct status, etc. The safety slave for safety process data communications is not connected. The NX Unit Mounting Setting for the safety slave for safety process data communications is set to <i>Disabled</i>. 			S			Z930
55000000 hex	Division by Zero	Division by zero was detected.	The divisor is zero.			S			Z930
55010000 hex	Cast Error	A casting error was detected.	A value was input that exceeded the range of the receiving variable.			S			Z930
55020000 hex	MUX Error	An MUX instruction error was detected.	The value of the selection input (K) to the MUX instruction is not correct.			S			Z930

Event code	Event name	Meaning	Assumed cause	Level					Reference
				Maj	Prt	Min	Obs	Info	
74A00000 hex	SF_Antivalent Error	An error was detected in execution of a safety function block.	Refer to information on the diagnostic code that is given for attached information 1 in the <i>NX-series Safety Control Unit Instructions Reference Manual</i> (Cat. No. Z931)			S			Z930
74A10000 hex	SF_EDM Error	An error was detected in execution of a safety function block.	Refer to information on the diagnostic code that is given for attached information 1 in the <i>NX-series Safety Control Unit Instructions Reference Manual</i> (Cat. No. Z931)			S			Z930
74A20000 hex	SF_EmergencyStop Error	An error was detected in execution of a safety function block.	Refer to information on the diagnostic code that is given for attached information 1 in the <i>NX-series Safety Control Unit Instructions Reference Manual</i> (Cat. No. Z931)			S			Z930
74A30000 hex	SF_EnabledSwitch Error	An error was detected in execution of a safety function block.	Refer to information on the diagnostic code that is given for attached information 1 in the <i>NX-series Safety Control Unit Instructions Reference Manual</i> (Cat. No. Z931)			S			Z930
74A40000 hex	SF_Equivalent Error	An error was detected in execution of a safety function block.	Refer to information on the diagnostic code that is given for attached information 1 in the <i>NX-series Safety Control Unit Instructions Reference Manual</i> (Cat. No. Z931)			S			Z930
74A50000 hex	SF_ESPE Error	An error was detected in execution of a safety function block.	Refer to information on the diagnostic code that is given for attached information 1 in the <i>NX-series Safety Control Unit Instructions Reference Manual</i> (Cat. No. Z931)			S			Z930
74A60000 hex	SF_GuardLocking Error	An error was detected in execution of a safety function block..	Refer to information on the diagnostic code that is given for attached information 1 in the <i>NX-series Safety Control Unit Instructions Reference Manual</i> (Cat. No. Z931)			S			Z930
74A70000 hex	SF_GuardMonitoring Error	An error was detected in execution of a safety function block.	Refer to information on the diagnostic code that is given for attached information 1 in the <i>NX-series Safety Control Unit Instructions Reference Manual</i> (Cat. No. Z931)			S			Z930
74A80000 hex	SF_ModeSelector Error	An error was detected in execution of a safety function block.	Refer to information on the diagnostic code that is given for attached information 1 in the <i>NX-series Safety Control Unit Instructions Reference Manual</i> (Cat. No. Z931)			S			Z930
74A90000 hex	SF_MutingPar Error	An error was detected in execution of a safety function block.	Refer to information on the diagnostic code that is given for attached information 1 in the <i>NX-series Safety Control Unit Instructions Reference Manual</i> (Cat. No. Z931)			S			Z930

Event code	Event name	Meaning	Assumed cause	Level					Reference
				Maj	Prt	Min	Obs	Info	
74AA0000 hex	SF_Muting-Par_2Sensor Error	An error was detected in execution of a safety function block.	Refer to information on the diagnostic code that is given for attached information 1 in the <i>NX-series Safety Control Unit Instructions Reference Manual</i> (Cat. No. Z931)			S			Z930
74AB0000 hex	SF_MutingSeq Error	An error was detected in execution of a safety function block.	Refer to information on the diagnostic code that is given for attached information 1 in the <i>NX-series Safety Control Unit Instructions Reference Manual</i> (Cat. No. Z931)			S			Z930
74AC0000 hex	SF_OutControl Error	An error was detected in execution of a safety function block.	Refer to information on the diagnostic code that is given for attached information 1 in the <i>NX-series Safety Control Unit Instructions Reference Manual</i> (Cat. No. Z931)			S			Z930
74AD0000 hex	SF_SafetyRequest Error	An error was detected in execution of a safety function block.	Refer to information on the diagnostic code that is given for attached information 1 in the <i>NX-series Safety Control Unit Instructions Reference Manual</i> (Cat. No. Z931)			S			Z930
74AE0000 hex	SF_Testable-SafetySensor Error	An error was detected in execution of a safety function block.	Refer to information on the diagnostic code that is given for attached information 1 in the <i>NX-series Safety Control Unit Instructions Reference Manual</i> (Cat. No. Z931)			S			Z930
74AF0000 hex	SF_Two-HandControl-TypesII Error	An error was detected in execution of a safety function block.	Refer to information on the diagnostic code that is given for attached information 1 in the <i>NX-series Safety Control Unit Instructions Reference Manual</i> (Cat. No. Z931)			S			Z930
74B00000 hex	SF_Two-HandControl-TypesIII Error	An error was detected in execution of a safety function block.	Refer to information on the diagnostic code that is given for attached information 1 in the <i>NX-series Safety Control Unit Instructions Reference Manual</i> (Cat. No. Z931)			S			Z930
80200000 hex	NX Unit I/O Communications Error	An I/O communications error occurred between the Communications Coupler Unit and the NX Unit.	<ul style="list-style-type: none"> The NX Unit is not mounted properly. The power cable for the Unit power supply is disconnected. Or, the wiring from the Unit power supply to the NX Units is incorrect. The power cable for the Unit power supply is broken. The voltage of the Unit power supply is outside the specified range. Or, the capacity of the Unit power supply is insufficient. There is a hardware error in the NX Unit. 			S			Z930

Event code	Event name	Meaning	Assumed cause	Level					Reference
				Maj	Prt	Min	Obs	Info	
80300000 hex	Safety Process Data Communications Timeout	A communications timeout occurred in safety process data communications with the Safety Control Unit.	<ul style="list-style-type: none"> A setting is not correct. The setting of the safety task period is too short. There is excessive noise. The Safety CPU Unit or safety slave entered a status where it could not continue safety process data communications. An error or status change occurred in the Communications Coupler Unit to which the Unit is connected, preventing correct process data communications. 			S			Z930
84F00000 hex	NX Bus I/O Communications Stopped	An error occurred in I/O communications between the Communications Coupler Unit and an NX Unit.	There is a hardware error in the Communications Coupler Unit or an NX Unit.			S			Z930
80220000 hex	NX Message Communications Error	An error was detected in message communications for an NX Unit and the message frame was discarded.	<ul style="list-style-type: none"> The message communications load is high. The communications cable is disconnected or broken. Message communications were cut off as the result of executing a synchronization or restoration operation on the Sysmac Studio or as the result of disconnecting an EtherCAT slave. 			S			Z930
90400000 hex	Event Log Cleared	The event log was cleared.	The event log was cleared by the user.					S	Z930
90430000 hex	Memory All Cleared	The Unit settings were cleared.	The Clear All Memory operation was performed.					S	Z930
951E0000 hex	Sysmac Studio Communications Connection Timeout	A communications timeout occurred between the Sysmac Studio and the Safety CPU Unit.	<ul style="list-style-type: none"> The communications cable was disconnected. 					S	Z930
951F0000 hex	Clear All Memory Rejected	Clearing all of memory failed.	<ul style="list-style-type: none"> The Clear All Memory operation was performed for the entire Slave Terminal. 					S	Z930

● Safety I/O Units

Event code	Event name	Meaning	Assumed cause	Level					Reference
				Maj	Prt	Min	Obs	Info	
05200000 hex	System Error	A hardware error was detected during self-diagnosis of the hardware.	<ul style="list-style-type: none"> Hardware has failed. A memory error occurred due to a transient cause, such as a software error or excessive noise. 			S			Z930
05210000 hex	Internal Circuit Error at Safety Input	A fault was detected in the internal circuit for the safety input terminal.	<ul style="list-style-type: none"> The internal circuit for the safety input terminal is faulty. A memory error or signal error occurred due to a transient cause, such as a software error or excessive noise. 			S			Z930
05220000 hex	Internal Circuit Error at Test Output	A fault was detected in the internal circuit for the test output terminal.	<ul style="list-style-type: none"> The internal circuit for the test output terminal is faulty. A memory error or signal error occurred due to a transient cause, such as a software error or excessive noise. 			S			Z930
05230000 hex	Internal Circuit Error at Safety Output	A fault was detected in the internal circuit for the safety output terminal.	<ul style="list-style-type: none"> The internal circuit for the safety output terminal is faulty. A memory error or signal error occurred due to a transient cause, such as a software error or excessive noise. 			S			Z930
35210000 hex	Safety Process Data Communications Not Established - Incorrect Unit Parameter Error	Safety process data communications was not established with the Safety CPU Unit.	<ul style="list-style-type: none"> The model or safety I/O terminal settings are not correct. 			S			Z930
35230000 hex	Safety Process Data Communications Not Established, Incorrect FSoE Slave Address Error	Safety process data communications was not established with the Safety CPU Unit because of an incorrect FSoE slave address.	<ul style="list-style-type: none"> The setting of the FSoE slave address in the safety process data communications settings is different from the setting in the Unit. 			S			Z930
35240000 hex	Safety Process Data Communications Not Established, Incorrect Frame Error	Safety process data communications was not established with the Safety CPU Unit because an incorrect frame was received.	<ul style="list-style-type: none"> An incorrect frame was received in safety process data communications. There is excessive noise. 			S			Z930
65200000 hex	I/O Power Supply Voltage Error	An incorrect I/O power supply voltage was detected.	<ul style="list-style-type: none"> The input power or output power is not supplied correctly. 			S			Z930
65210000 hex	Output Power Interrupt Circuit Error	An error was detected by the output power interruption test.	<ul style="list-style-type: none"> The wiring is not correct or there is a fault in the hardware. 			S			Z930
65220000 hex	External Test Signal Failure at Safety Input	An error was detected in test pulse evaluation of the safety input terminals.	<ul style="list-style-type: none"> The positive power supply wire is in contact with the input signal line. The input signal lines are shorted. The external device is faulty. 			S			Z930

Event code	Event name	Meaning	Assumed cause	Level					Reference
				Maj	Prt	Min	Obs	Info	
65230000 hex	Discrepancy Error at Safety Input	An error was detected in discrepancy evaluation of safety input terminals.	<ul style="list-style-type: none"> There is a ground fault or disconnection in the input signal line. The connected device is faulty. The setting of the discrepancy time is not correct. Chattering occurred in the input signal from the external input device, such as a safety door. 			S			Z930
65240000 hex	Overload Detected at Test Output	An overcurrent was detected at the test output terminal.	<ul style="list-style-type: none"> There is a ground fault on the output signal line. The external device is faulty. 			S			Z930
65250000 hex	Stuck-at-high Detected at Test Output	It was detected that the test output terminal is stuck ON.	<ul style="list-style-type: none"> The positive power supply line is in contact with the output signal line. The internal circuit is faulty. A memory error or signal error occurred due to a transient cause, such as a software error or excessive noise. 			S			Z930
65270000 hex	Short Circuit Detected at Safety Output	A ground fault was detected on the safety output terminal.	<ul style="list-style-type: none"> There is a ground fault on the output signal line. 			S			Z930
65280000 hex	Stuck-at-high Detected at Safety Output	It was detected that the safety output terminal is stuck ON.	<ul style="list-style-type: none"> The positive power supply line is in contact with the output signal line. The output power supply is outside the specifications. The internal circuit is faulty. A memory error or signal error occurred due to a transient cause, such as a software error or excessive noise. 			S			Z930
80200000 hex	NX Unit I/O Communications Error	An I/O communications error occurred between the Communications Coupler Unit and the NX Unit.	<ul style="list-style-type: none"> The NX Unit is not mounted properly. The power cable for the Unit power supply is disconnected. Or, the wiring from the Unit power supply to the NX Units is incorrect. The power cable for the Unit power supply is broken. The voltage of the Unit power supply is outside the specified range. Or, the capacity of the Unit power supply is insufficient. There is a hardware error in the NX Unit. 			S			Z930

Event code	Event name	Meaning	Assumed cause	Level					Reference
				Maj	Prt	Min	Obs	Info	
80300000 hex	Safety Process Data Communications Timeout	A communications timeout occurred in safety process data communications with the Safety Control Unit.	<ul style="list-style-type: none"> A setting is not correct. The setting of the safety task period is too short. There is excessive noise. The Safety CPU Unit or safety slave entered a status where it could not continue safety process data communications. An error or status change occurred in the Communications Coupler Unit to which the Unit is connected, preventing correct process data communications. 			S			Z930
84F10000 hex	NX Bus I/O Communications Stopped	An error occurred in I/O communications between the Communications Coupler Unit and an NX Unit.	There is a hardware error in the Communications Coupler Unit or an NX Unit.			S			Z930
80220000 hex	NX Message Communications Error	An error was detected in message communications for an NX Unit and the message frame was discarded.	<ul style="list-style-type: none"> The message communications load is high. The communications cable is disconnected or broken. Message communications were cut off as the result of executing a synchronization or restoration operation on the Sysmac Studio or as the result of disconnecting an EtherCAT slave. 				S		Z930
90400000 hex	Event Log Cleared	The event log was cleared.	The event log was cleared by the user.					S	Z930
90430000 hex	Memory All Cleared	The Unit settings were cleared.	The Clear All Memory operation was performed.					S	Z930

NX-series Load Cell Input Units

The section provides a table of errors (events) that can occur in the following Unit.

NX-RS□□□□

The manual names are given below for the catalog numbers given in the *Reference* column of the event table.

Cat. No.	Manual name
W565	NX-series Load Cell Input Unit User's Manual

Event code	Event name	Meaning	Assumed cause	Level					Reference
				Maj	Prt	Min	Obs	Info	
00200000 hex	Non-volatile Memory Hardware Error	An error occurred in non-volatile memory.	<ul style="list-style-type: none"> Non-volatile memory failure 			S			W565
05120000 hex	A/D Conversion Error	AD conversion was not performed by the AD converter.	<ul style="list-style-type: none"> EXC+ terminal and EXC- terminal are short-circuited. Noise A/D converter failure 			S			W565

Event code	Event name	Meaning	Assumed cause	Level					Reference
				Maj	Prt	Min	Obs	Info	
10410000 hex	Control Parameter Error in Master	An error occurred in the control parameters that are saved in the master.	<p>For the NX bus of CPU Units</p> <ul style="list-style-type: none"> The power supply to the CPU Unit was turned OFF while writing the Unit operation settings was in progress. Or there is an error in the area of the non-volatile memory in the CPU Unit in which the Unit operation settings for the relevant NX Unit are saved. <p>For Communications Coupler Units</p> <ul style="list-style-type: none"> The power supply to the Communications Coupler Unit was turned OFF while writing the Unit operation settings was in progress. Or there is an error in the area of the non-volatile memory in the Communications Coupler Unit in which the Unit operation settings for the relevant NX Unit are saved. 			S			W565
10440000 hex	Unit Calibration Value Error	There is an error in the area in which the Unit calibration values are saved.	<ul style="list-style-type: none"> There is an error in the area of the non-volatile memory in which the Unit calibration values are saved. 			S			W565
10450000 hex	Actual Load Calibration Value Error	There is an error in the area in which the actual load calibration values are saved.	<ul style="list-style-type: none"> There is an error in the area of the non-volatile memory in which the actual load calibration values are saved. 			S			W565
40200000 hex	NX Unit Processing Error	A fatal error occurred in an NX Unit.	<ul style="list-style-type: none"> An error occurred in the software. 			S			W565
65130000 hex	Sensor Disconnected Error	A disconnection with the load cell was detected.	<ul style="list-style-type: none"> Wiring with the load cell is not connected. Wiring with the load cell is broken. The input signal exceeds the input conversion range. Load cell failure. 			S			W565

Event code	Event name	Meaning	Assumed cause	Level					Reference
				Maj	Prt	Min	Obs	Info	
80200000 hex	NX Unit I/O Communications Error	An I/O communications error occurred in an NX Unit.	<p>For the NX bus of CPU Units</p> <ul style="list-style-type: none"> An error that prevents normal NX bus communications occurred in a CPU Unit. An NX Unit is not mounted properly. The power cable for the Unit power supply is disconnected, or the wiring from the Unit power supply to the NX Units is incorrect. The power cable for the Unit power supply is broken. The voltage of the Unit power supply is outside the specified range, or the capacity of the Unit power supply is insufficient. There is a hardware error in an NX Unit. <p>For Communications Coupler Units</p> <ul style="list-style-type: none"> An error that prevents normal NX bus communications occurred in a Communications Coupler Unit. The NX Unit is not mounted properly. The power cable for the Unit power supply is disconnected. Or, the wiring from the Unit power supply to the NX Units is incorrect. The power cable for the Unit power supply is broken. The voltage of the Unit power supply is outside the specified range. Or, the capacity of the Unit power supply is insufficient. There is a hardware error in the NX Unit. 			S			W565

Event code	Event name	Meaning	Assumed cause	Level					Reference
				Maj	Prt	Min	Obs	Info	
80210000 hex	NX Unit Output Synchronization Error	An output synchronization error occurred in the NX Unit.	<p>For the NX bus of CPU Units</p> <ul style="list-style-type: none"> I/O refreshing on the NX bus is not performed normally due to an error in the CPU Unit. <p>For Communications Coupler Units</p> <ul style="list-style-type: none"> The communications cable connected to the Communications Coupler Unit is broken or the connection is faulty. The communications cable is affected by noise. 			S			W565
80240000 hex	NX Unit Clock Not Synchronized Error	A time information error occurred in an NX Unit.	<p>For the NX bus of CPU Units</p> <ul style="list-style-type: none"> There is a hardware error in an NX Unit. There is a hardware error in a CPU Unit. <p>For Communications Coupler Units</p> <ul style="list-style-type: none"> There is a hardware error in an NX Unit. There is a hardware error in an EtherCAT Coupler Unit. 			S			W565
65140000 hex	Over Range	The input signal from the load cell exceeded the upper limit of the input conversion range.	<ul style="list-style-type: none"> Wiring with the load cell is not connected. Wiring with the load cell is broken. EXC+ terminal and EXC- terminal are short-circuited. Load cell failure. A load cell with which the rated output exceeds the input range of the Load Cell Input Unit is used. A load that exceeds the rated capacity is applied to the load cell. Noise 			U	S		W565
65150000 hex	Under Range	The input signal from the load cell went below the lower limit of the input conversion range.	<ul style="list-style-type: none"> Wiring with the load cell is not connected. Wiring with the load cell is broken. EXC+ terminal and EXC- terminal are short-circuited. Load cell failure. A load cell with which the rated output exceeds the input range of the Load Cell Input Unit is used. A load that exceeds the rated capacity is applied to the load cell. Noise 			U	S		W565

Event code	Event name	Meaning	Assumed cause	Level					Reference
				Maj	Prt	Min	Obs	Info	
80220000 hex	NX Message Communications Error	An error was detected in message communications and the message frame was discarded.	<p>For the NX bus of CPU Units</p> <ul style="list-style-type: none"> The message communications load is high. <p>For Communications Coupler Units</p> <ul style="list-style-type: none"> The message communications load is high. The communications cable is disconnected or broken. Message communications were cutoff in communications. 				S		W565
90400000 hex	Event Log Cleared	The event log was cleared.	<ul style="list-style-type: none"> The event log was cleared by the user. 					S	W565

NX-series IO-Link Master Units

The section provides a table of errors (events) that can occur in the following Unit.

NX-ILM□□□

The manual name is given below for the catalog numbers given in the *Reference* column of the event table.

Cat. No.	Manual name
W570	IO-Link System User's Manual

Event code	Event name	Meaning	Assumed cause	Level					Reference
				Maj	Prt	Min	Obs	Info	
00200000 hex	Non-volatile Memory Hardware Error	An error occurred in non-volatile memory.	<ul style="list-style-type: none"> Non-volatile memory failure 			S			W570
10410000 hex	Control Parameter Error in Master	An error occurred in the control parameters that are saved in the master.	<p>For the NX bus of CPU Units</p> <ul style="list-style-type: none"> The power supply to the CPU Unit was turned OFF while writing the Unit operation settings was in progress. Or there is an error in the area of the non-volatile memory in the CPU Unit in which the Unit operation settings for the relevant NX Unit are saved. <p>For Communications Coupler Units</p> <ul style="list-style-type: none"> The power supply to the Communications Coupler Unit was turned OFF while writing the Unit operation settings was in progress. Or there is an error in the area of the non-volatile memory in the Communications Coupler Unit in which the Unit operation settings for the relevant NX Unit are saved. 			S			W570
40200000 hex	NX Unit Processing Error	A fatal error occurred in an NX Unit.	<ul style="list-style-type: none"> An error occurred in the software. 			S			W570

Event code	Event name	Meaning	Assumed cause	Level					Reference
				Maj	Prt	Min	Obs	Info	
80200000 hex	NX Unit I/O Communications Error	An I/O communications error occurred in an NX Unit.	<p>For the NX bus of CPU Units</p> <ul style="list-style-type: none"> An error that prevents normal NX bus communications occurred in a CPU Unit. An NX Unit is not mounted properly. The power cable for the Unit power supply is disconnected, or the wiring from the Unit power supply to the NX Units is incorrect. The power cable for the Unit power supply is broken. The voltage of the Unit power supply is outside the specified range, or the capacity of the Unit power supply is insufficient. There is a hardware error in an NX Unit. <p>For Communications Coupler Units</p> <ul style="list-style-type: none"> An error that prevents normal NX bus communications occurred in a Communications Coupler Unit. An NX Unit is not mounted properly. The power cable for the Unit power supply is disconnected. Or, the wiring from the Unit power supply to the NX Units is incorrect. The power cable for the Unit power supply is broken. The voltage of the Unit power supply is outside the specified range. Or, the capacity of the Unit power supply is insufficient. There is a hardware error in the NX Unit. 			S			W570
80240000 hex	NX Unit Clock Not Synchronized Error	A time information error occurred in an NX Unit.	<p>For the NX bus of CPU Units</p> <ul style="list-style-type: none"> There is a hardware error in an NX Unit. There is a hardware error in a CPU Unit. <p>For Communications Coupler Units</p> <ul style="list-style-type: none"> There is a hardware error in an NX Unit. There is a hardware error in an EtherCAT Coupler Unit. 			S			W570
848F0000 hex	Device Configuration Verification Error	The connected device is different from the IO-Link device registered for a port of the IO-Link Master.	The connected device is different from the IO-Link device registered for a port of the IO-Link Master.			S			W570

Event code	Event name	Meaning	Assumed cause	Level					Reference
				Maj	Prt	Min	Obs	Info	
84970000 hex	I/O Cable Short-circuit	There is a short-circuit in the cable that connects the IO-Link master and device.	There is a short-circuit in the I/O cable. An IO-Link device has failed.			S			W570
849A0000 hex	IO-Link Communications Module Processing Error	A hardware failure occurred in the IO-Link Communications Module.	A hardware failure occurred.			S			W570
80220000 hex	NX Message Communications Error	An error was detected in message communications and the message frame was discarded.	For the NX bus of CPU Units • The message communications load is high. For Communications Coupler Units • The message communications load is high. • The communications cable is disconnected or broken. • Message communications were cutoff in communications.				S		W570
848C0000 hex	Error-level Device Event	An error-level event occurred in the IO-Link device.	Use CX-Configurator FDT to confirm the event code of the IO-Link device.				S		W570
848D0000 hex	IO-Link Communications Error	An error occurred in IO-Link communications with a device.	The I/O cable is broken. Or, the IO-Link device is disconnected from the port. The communications were affected by noise or IO-Link device failure.				S		W570
84990000 hex	Warning-level Device Event Flag	A warning-level event occurred in the IO-Link device.	Use CX-Configurator FDT to confirm the event code of the IO-Link device.				S		W570
84950000 hex	IO-Link Device Configuration Information Created	IO-Link device configuration information was created.	IO-Link device configuration information was created.					S	W570
84980000 hex	I/O Power Supply ON Detected	The I/O power supply ON was detected in several times.	The I/O power supply ON was detected in several times.					S	W570
90400000 hex	Event Log Cleared	The event log was cleared.	• The event log was cleared by the user.					S	W570

3-1-13 Errors in EtherCAT Slaves

This section provides tables of the errors (events) for which the following OMRON EtherCAT slaves provide notification to the NJ/NX-series CPU Unit.

- GX-series EtherCAT Slave Units
- Servo 1S (1S-series AC Servo Drives with Built-in EtherCAT Communications)
R88M-1□ and R88D-1SN□-ECT
- Servo G5 (G5-series AC Servo Drives with Built-in EtherCAT Communications) and G5 Linear (G5-series Linear Motors/Drives with Built-in EtherCAT Communications Linear Motor Type)
- MX2/RX-series Inverters with EtherCAT Communications Units
- FH-series Vision Systems
- EtherCAT FQ-M-series Specialized Vision Sensors for Positioning
- E3X-series Fiber Sensors with EtherCAT Communications Unit for Digital Sensors
- E3NW-ECT EtherCAT Digital Sensor Communications Unit
- ZW-CE1□T Confocal Fiber Type Displacement Sensor

GX-series EtherCAT Slave Units

The manual names are given below for the catalog numbers given in the *Reference* column of the event table.

Cat. No.	Manual name
W488	GX-series EtherCAT Slave Units User's Manual
W570	IO-Link System User's Manual

● Block I/O

Event code	Event name	Meaning	Assumed cause	Level					Reference
				Maj	Prt	Min	Obs	Info	
04A00000 hex	Expansion Unit Hardware Error	An Expansion Unit was disconnected during operation or a signal between the Slave Unit and Expansion Unit was broken.	<ul style="list-style-type: none"> • The Expansion Unit is disconnected. • The Expansion Unit is faulty. 			S			W488
04A20000 hex	Slave Hardware Error	A hardware error occurred in the Slave Unit.	<ul style="list-style-type: none"> • The Slave Unit is faulty. 			S			W488
14A00000 hex	Non-volatile Memory Checksum Error	An error occurred in the control parameters.	<ul style="list-style-type: none"> • Noise 			S			W488
24610000 hex	Switch Setting Error	The setting switch is set out of range.	<ul style="list-style-type: none"> • The analog range that is set on the switch is outside the setting range. 			S			W488
64CC0000 hex	I/O Disconnection Detected	An I/O signal line is disconnected.	<ul style="list-style-type: none"> • I/O signal wiring is disconnected or has a faulty connection. • An I/O signal line is disconnected. 			S			W488
84A00000 hex	Slave Unit Verification Error	A verification error occurred for the SII.	<ul style="list-style-type: none"> • An error occurred in the control board. 			S			W488

Event code	Event name	Meaning	Assumed cause	Level					Reference
				Maj	Prt	Min	Obs	Info	
04A10000 hex	Non-volatile Memory Hardware Error	An error occurred in non-volatile memory.	<ul style="list-style-type: none"> Non-volatile memory failure 				S		W488

● IO-Link Master Unit

Event code	Event name	Meaning	Assumed cause	Level					Reference
				Maj	Prt	Min	Obs	Info	
04A10000 hex	Non-volatile Memory Hardware Error	An error occurred in non-volatile memory.	<ul style="list-style-type: none"> Non-volatile memory failure 			S			W570
04A20000 hex	Slave Hardware Error	A hardware error occurred in the slave unit.	<ul style="list-style-type: none"> The slave unit failed. 			S			W570
14A00000 hex	Non-volatile Memory Checksum Error	An error occurred in the control parameters.	<ul style="list-style-type: none"> Noise 			S			W570
847C0000 hex	Device Configuration Verification Error	The connected device is different from the IO-Link device registered for a port of the IO-Link Master.	The connected device is different from the IO-Link device registered for a port of the IO-Link Master.			S			W570
84840000 hex	I/O Cable Short-circuit	There is a short-circuit in the cable that connects the IO-Link master and device.	<ul style="list-style-type: none"> There is a short-circuit in the I/O cable. An IO-Link device has failed. 			S			W570
84870000 hex	IO-Link Communications Module Processing Error	A hardware failure occurred in the IO-Link Communications Module.	A hardware failure occurred.			S			W570
84A00000 hex	Slave Unit Verification Error	An error occurred in Slave Unit verification.	An error occurred in the control board.			S			W570
84790000 hex	Error-level Device Event	An error-level event occurred in the IO-Link device.	Use CX-Configurator FDT to confirm the event code of the IO-Link device.			S			W570
847A0000 hex	IO-Link Communications Error	An error occurred in IO-Link communications with a device.	<ul style="list-style-type: none"> The I/O cable is broken. Or, the IO-Link device is disconnected from the port. An IO-Link device has failed. The communications are affected by noise. 			S			W570

Event code	Event name	Meaning	Assumed cause	Level					Reference
				Maj	Prt	Min	Obs	Info	
84860000 hex	Warning-level Device Event Flag	A warning-level event occurred in the IO-Link device.	Use CX-Configurator FDT to confirm the event code of the IO-Link device.				S		W570
84820000 hex	IO-Link Device Configuration Information Created	IO-Link device configuration information was created.	IO-Link device configuration information was created.					S	W570
84850000 hex	I/O Power Supply ON Detected	The I/O power supply ON was detected in several times.	The I/O power supply ON was detected in several times.					S	W570

Servo 1S (1S-series AC Servo Drives with Built-in EtherCAT Communications) R88M-1□ and R88D-1SN□-ECT

The section provides a table of the errors (events) that can occur in R88M-1□ (AC Servomotors) or R88D-1SN□-ECT (AC Servo Drives).

The manual name is given below for the catalog numbers given in the *Reference* column of the event table.

Cat. No.	Manual name
I586	AC Servomotors/Servo Drives 1S-series with Built-in EtherCAT Communications User's Manual

Event code	Event name	Meaning	Assumed cause	Level					Reference
				Maj	Prt	Min	Obs	Info	
05430000 hex	ESC Error	An error occurred in the EtherCAT slave communications controller.	<ul style="list-style-type: none"> Error of the EtherCAT slave communications controller or false detection when the AL status code is 0051 hex Error access from the non-OMRON EtherCAT master when the AL status code is 0050 hex 			S			I586
08390000 hex	Power Module Error	An error was detected in the power module.	<ul style="list-style-type: none"> There is a short-circuit, ground fault, or contact failure on the U, V, or W motor cable There is a short-circuit on the wiring of External Regeneration Resistor or the resistance value is small The insulation resistance failed between the U, V, or W motor cable and the motor ground wire Servo Drive failure 			S			I586
083B0000 hex	Self-diagnosis Error	An error was detected by the self-diagnosis of the safety function.	<ul style="list-style-type: none"> False detection due to a data read error that was caused by excessive noise Hardware failure 			S			I586
083C0000 hex	Main Circuit Temperature Monitoring Circuit Failure	A temperature monitoring circuit failure was detected on the main circuit.	<ul style="list-style-type: none"> Broken wiring of the thermistor, temperature monitoring circuit failure 			S			I586

Event code	Event name	Meaning	Assumed cause	Level					Reference
				Maj	Prt	Min	Obs	Info	
083D0000 hex	Fan Error	The rotation speed of the fan is 40% or less of the rating and the cooling performance decreases.	<ul style="list-style-type: none"> There is a foreign matter in the cooling fan and it blocks the rotation Cooling fan failure 			S			I586
083F0000 hex	Regeneration Processing Error	The regeneration processing was stopped to protect the Regeneration Resistor.	<ul style="list-style-type: none"> The regeneration processing is set inappropriately The Regeneration Resistor is selected inappropriately The Regeneration Resistor is used for continuous regenerative braking The applied power supply voltage is higher than the specified value Regeneration Resistor failure 			S			I586
08410000 hex	Overvoltage Error	The main circuit power supply voltage (P-N voltage) exceeded the operation guarantee range.	<ul style="list-style-type: none"> The P-N voltage exceeded the specified value The input voltage increased The Regeneration Resistor wiring is broken The External Regeneration Resistor is set or selected inappropriately Servo Drive failure 			S			I586
08420000 hex	Motor Overheat Error	The encoder detected the temperature that exceeded the protection level of motor.	<ul style="list-style-type: none"> The temperature is high around the motor The motor is overloaded Encoder failure 			S			I586
08430000 hex	1-rotation Counter Error	The encoder detected a one-rotation counter error.	<ul style="list-style-type: none"> There is excessive noise Failure due to vibration, impact, condensation, foreign matter, etc. 			S			I586
08440000 hex	Overspeed Error	The encoder detected the overspeed.	<ul style="list-style-type: none"> The motor was rotated by external forces Encoder failure and false detection 			S			I586
08450000 hex	Encoder Memory Error	The encoder detected a non-volatile memory error.	<ul style="list-style-type: none"> False detection due to a data read error that was caused by excessive noise Non-volatile memory failure 			S			I586
08460000 hex	Absolute Position Detection Error	The encoder detected a multi-rotation counter error.	<ul style="list-style-type: none"> A detection error was detected in the multi-rotation detection section of the encoder There is excessive noise 			S			I586
08480000 hex	Main Power Supply Undervoltage (insufficient voltage between P and N)	The main circuit power supply voltage fell below the operation guarantee range during Servo ON.	<ul style="list-style-type: none"> Incorrect wiring of the main circuit power supply The low power supply voltage is applied to the Servo Drive The long time was set in Momentary Hold Time and the voltage was decreased momentarily Servo Drive failure 			S			I586

Event code	Event name	Meaning	Assumed cause	Level					Reference
				Maj	Prt	Min	Obs	Info	
08490000 hex	Overcurrent Error	The current flowing to the motor exceeded the protection level.	<ul style="list-style-type: none"> • There is a short-circuit, ground fault, or contact failure on the U, V, or W motor cable • There is a short-circuit on the wiring of External Regeneration Resistor • The insulation resistance failed between the U, V, or W motor cable and the motor ground wire • False detection due to the noise • Servo Drive failure 			S			1586
084A0000 hex	Encoder Communications Disconnection Error	The communications disconnection was detected between the encoder and the Servo Drive.	<ul style="list-style-type: none"> • Noise into the encoder cable • Contact failure of the signal line, and disconnection of the encoder • Power supply undervoltage to the encoder • Encoder failure 			S			1586
084B0000 hex	Encoder Communications Error	Illegal data was received from the encoder the specified number of times.	<ul style="list-style-type: none"> • Noise into the encoder cable • Contact failure of the signal line, and disconnection of the encoder • Power supply undervoltage to the encoder 			S			1586
084D0000 hex	Non-volatile Memory Hardware Error	An error occurred on the non-volatile memory.	<ul style="list-style-type: none"> • False detection due to a data read error that was caused by excessive noise • Non-volatile memory failure 			S			1586
18230000 hex	Absolute Encoder Multi-rotation Counter Error	The encoder detected a multi-rotation counter error.	<ul style="list-style-type: none"> • A temporary error occurred in the encoder multi-rotation detection function due to vibration, impact, or condensation • Encoder failure 			S			1586
18380000 hex	System Error	A hardware error due to the self-diagnosis and a fatal software error were detected.	<ul style="list-style-type: none"> • False detection due to a data read error that was caused by excessive noise • A fatal software error was detected • Hardware failure 			S			1586
183A0000 hex	Non-volatile Memory Data Error	An error of data saved in the non-volatile memory was detected.	<ul style="list-style-type: none"> • Power interruption or noise occurred while parameters other than the safety were saved • Power interruption or noise occurred while the motor identity information was saved • Power interruption or noise occurred while safety parameters were saved 			S			1586
246D0000 hex	Motor Non-conformity	The Servo Drive and motor combination is not correct.	<ul style="list-style-type: none"> • The Servo Drive and motor combination is not correct 			S			1586

Event code	Event name	Meaning	Assumed cause	Level					Reference
				Maj	Prt	Min	Obs	Info	
28080000 hex	Main Circuit Power Supply Phase Loss Error	The phase loss of the main circuit power supply was detected.	<ul style="list-style-type: none"> Incorrect wiring, for example the single-phase power supply is input to a 3-phase input type Servo Drive In the case where the single-phase power supply is input to a single- and 3-phase input type Servo Drive, the phase loss detection is enabled. The power supply voltage is low or insufficient Broken wiring of the main circuit power supply input Servo Drive failure 			S			I586
280D0000 hex	Runaway Detected	The motor rotated in the direction opposite to the command.	<ul style="list-style-type: none"> There is incorrect wiring of the motor cable or a broken cable. The motor rotated in the direction opposite to the command by external forces. 			S			I586
357D0000 hex	DC Setting Error	A mistake was made in the DC Mode operation setting.	<ul style="list-style-type: none"> A mistake was made in the DC Mode operation setting 			S			I586
357E0000 hex	Synchronization Cycle Setting Error	When the DC mode was established, the cycle time was set to the inoperable value.	<ul style="list-style-type: none"> The variable PDO mapping is used, and the number of objects is more than the maximum number of mapped objects for the cycle time The cycle time setting is incorrect 			S			I586
357F0000 hex	Mailbox Setting Error	An incorrect mailbox setting of Sync Manager was detected.	<ul style="list-style-type: none"> An incorrect mailbox setting of Sync Manager was detected 			S			I586
35800000 hex	RxPDO Setting Error	An RxPDO setting error was detected.	<ul style="list-style-type: none"> The RxPDO setting of EtherCAT master is incorrect Servo Drive failure 			S			I586
35810000 hex	TxPDO Setting Error	A TxPDO setting error was detected.	<ul style="list-style-type: none"> The TxPDO setting of EtherCAT master is incorrect Servo Drive failure 			S			I586
35820000 hex	RxPDO Mapping Error	An incorrect RxPDO was set.	<ul style="list-style-type: none"> An incorrect RxPDO was set, such as out of the allowable range of Index, Subindex, or size 			S			I586
35830000 hex	TxPDO Mapping Error	An incorrect TxPDO was set.	<ul style="list-style-type: none"> An incorrect RxPDO was set, such as out of the allowable range of Index, Subindex, or size 			S			I586
35840000 hex	PDO WDT Setting Error	An incorrect PDO WDT setting was detected.	<ul style="list-style-type: none"> An incorrect PDO WDT setting was detected 			S			I586
35850000 hex	Node Address Updated	The node address is changed to a value of the ID switches.	<ul style="list-style-type: none"> The node address is changed from a set value in Sysmac Studio to a value of the ID switches 			S			I586
35860000 hex	SM Event Mode Setting Error	The unsupported SM Event Mode was set.	<ul style="list-style-type: none"> The unsupported SM Event Mode was set 			S			I586

3 Error Tables

Event code	Event name	Meaning	Assumed cause	Level					Reference
				Maj	Prt	Min	Obs	Info	
38570000 hex	Function Setting Error	The function that was set does not support the communications period.	<ul style="list-style-type: none"> The electronic gear ratio was not 1:1 when the communications period was set to 125 μs. The Backlash Compensation was enabled when the communications period was set to 125 μs. 			S			1586
38780000 hex	General Input Allocation Duplicate Error	More than one function input is allocated to one general input.	<ul style="list-style-type: none"> More than one function input is allocated to one general input 			S			1586
38790000 hex	General Output Allocation Duplicate Error	More than one function output is allocated to one general output.	<ul style="list-style-type: none"> More than one function output is allocated to one general output 			S			1586
387B0000 hex	Pulse Output Setting Error	The dividing numerator exceeded the dividing denominator when the Encoder Dividing Pulse Output - Dividing Denominator was set to a value other than 0.	<ul style="list-style-type: none"> The dividing numerator exceeded the dividing denominator when the Encoder Dividing Pulse Output - Dividing Denominator was set to a value other than 0 			S			1586
387C0000 hex	Motor Replacement Detected	The connected motor is different from the motor that was connected the last time.	<ul style="list-style-type: none"> The motor was replaced The Servo Drive was replaced 			S			1586
387F0000 hex	Electronic Gear Setting Error	The electronic gear ratio exceeded the allowable range.	<ul style="list-style-type: none"> The electronic gear ratio exceeded the allowable range 			S			1586
38800000 hex	Servo Drive Overheat	The internal temperature of Servo Drive exceeded the circuit protection level.	<ul style="list-style-type: none"> The ambient temperature of the Servo Drive exceeded the specified value Overload 			S			1586
38810000 hex	Overload Error	The Load Ratio of Servo Drive or motor (4150-81 hex) exceeded 100%.	<ul style="list-style-type: none"> Operation was continued for a long time with high load There is incorrect wiring of the motor cable or a broken cable Increase in friction 			S			1586
38820000 hex	Regeneration Overload Error	The Regeneration Load Ratio (4310-81 hex) exceeded the regeneration overload ratio.	<ul style="list-style-type: none"> The regeneration processing is set inappropriately The Regeneration Resistor is selected inappropriately The Regeneration Resistor is used for continuous regenerative braking The applied power supply voltage is higher than the specified value Regeneration Resistor failure 			S			1586
38830000 hex	Excessive Position Deviation Error	The position deviation is greater than or equal to the value set in the Following error window.	<ul style="list-style-type: none"> The motor operation does not follow the command The value of Following error window is small 			S			1586

Event code	Event name	Meaning	Assumed cause	Level					Reference
				Maj	Prt	Min	Obs	Info	
38840000 hex	Excessive Speed Deviation Error	The speed deviation is greater than or equal to the value set in the Excessive Velocity Deviation Detection Level.	<ul style="list-style-type: none"> The motor operation does not follow the command because a parameter value is inappropriate The output axis of motor is limited on the operation by external forces The value of the Excessive Velocity Deviation Detection Level is inappropriate 			S			I586
38850000 hex	Excessive Speed Error	The feedback motor speed is greater than or equal to the value set in the Excessive Speed Detection Level.	<ul style="list-style-type: none"> The velocity command value is too large Overshooting occurred The motor was rotated by external forces 			S			I586
38860000 hex	Following Error Counter Overflow	The following error value exceeded the range from -2147483648 to 2147483647.	<ul style="list-style-type: none"> The motor operation does not follow the command The motor is rotated or limited on the operation by external forces 			S			I586
38870000 hex	Absolute Encoder Counter Overflow Error	The multi-rotation counter of the encoder exceeded the maximum number of rotations.	<ul style="list-style-type: none"> An inappropriate value was set in the Encoder - Operation Selection when Using Absolute Encoder (4510-01 hex) The multi-rotation number of the encoder exceeded the maximum number of rotations 			S			I586
38880000 hex	Safety Communications Setting Error	Safety process data communications were not established with the Safety CPU Unit because of an incorrect communications setting.	<ul style="list-style-type: none"> The watchdog time was set incorrectly The processing was not completed within the watchdog time because communications were not established due to the noise 			S			I586
38890000 hex	Safety Frame Error	Safety process data communications were not established with the Safety CPU Unit because an incorrect frame was received.	<ul style="list-style-type: none"> An incorrect frame was received in safety process data communications There is excessive noise 			S			I586
388A0000 hex	Safety Parameter Error	Safety process data communications were not established with the Safety CPU Unit because an incorrect parameter was received.	<ul style="list-style-type: none"> The set safety slave model is incorrect 			S			I586
388B0000 hex	FSoE Slave Address Error	Safety process data communications were not established with the Safety CPU Unit because of an incorrect FSoE slave address.	<ul style="list-style-type: none"> The setting of the FSoE slave address in the safety process data communications settings is different from the setting in the Unit 			S			I586

Event code	Event name	Meaning	Assumed cause	Level					Reference
				Maj	Prt	Min	Obs	Info	
48080000 hex	FPGA WDT Error	An FPGA error was detected.	<ul style="list-style-type: none"> False detection due to a data read error that was caused by excessive noise Hardware failure 			S			1586
64E30000 hex	Drive Prohibition Input Error	Both the Positive Drive Prohibition (POT) and the Negative Drive Prohibition Input (NOT) turned ON.	<ul style="list-style-type: none"> An error occurred on the switch, wire, power supply, and wiring that were connected to the Positive Drive Prohibition (POT) or Negative Drive Prohibition Input (NOT) False detection occurred because the control signal power supply was turned ON slowly 			S			1586
68200000 hex	Drive Prohibition Detected	The operation was stopped according to the user setting because the motor ran in the prohibited direction when the Drive Prohibition was enabled.	<ul style="list-style-type: none"> Incorrect or broken wiring of Positive Drive Prohibition Input (POT) or Negative Drive Prohibition Input (NOT) Incorrect setting of the Drive Prohibition Input 			S			1586
68210000 hex	Control Right Release Error	Communications between the Sysmac Studio and Servo Drive were interrupted while a specific function was used from the Sysmac Studio.	<ul style="list-style-type: none"> The USB cable or EtherCAT cable was disconnected during the connection with the Sysmac Studio There is excessive noise A command sent from the Sysmac Studio was not sent to the Servo Drive because the computer was in a busy state or the like 			S			1586
68220000 hex	Error Stop Input	The Error Stop Input (ESTP) is active.	<ul style="list-style-type: none"> The Error Stop Input (ESTP) was input The Error Stop Input (ESTP) is incorrectly wired 			S			1586
68230000 hex	Software Limit Exceeded	The Position actual value detected the position that exceeded the value set in the Software Position Limit, and stopped the operation according to the user setting.	<ul style="list-style-type: none"> Incorrect setting of Software Position Limit When the Software Position Limit - Stop Selection was set to <i>Stop according to the setting of Fault reaction option code</i>, the position exceeded the value set in the Software Position Limit 			S			1586
78200000 hex	Pulse Output Overspeed Error	The speed, which exceeded the frequency that could be output by the Encoder Dividing Pulse Output function, was detected.	<ul style="list-style-type: none"> The dividing ratio setting is inappropriate for the actual usage condition 			S			1586

Event code	Event name	Meaning	Assumed cause	Level					Reference
				Maj	Prt	Min	Obs	Info	
78210000 hex	Brake Interlock Error	The Brake Interlock Output (BKIR) was output by the Timeout at Servo OFF.	<ul style="list-style-type: none"> The Brake Interlock Output (BKIR) was output because the motor rotation speed did not decrease to or less than the speed set in the Threshold Speed at Servo OFF within the time set in the Timeout at Servo OFF when Servo OFF was performed during the motor operation 			S			I586
78230000 hex	Command Error	A mistake was made in using a command.	<ul style="list-style-type: none"> When bit 9 (Remote) of the Statusword was set to 1 (remote), and the Servo Drive was in <i>Operation enabled</i> state (Servo ON), the Servo Drive received a command to change the communications state from Operational to another state (Init, Pre-Operational, or Safe-Operational) A mode of operation other than the hm mode was set during the homing operation Modes of operation was set to pp, pv or hm mode when the communications period was set to shorter than 250 μs 			S			I586
84B10000 hex	EtherCAT State Change Error	A communications state change command was received for which the current communications state could not be changed.	<ul style="list-style-type: none"> A communications state change command was received for which the current communications state could not be changed 			S			I586
84B20000 hex	EtherCAT Illegal State Change Error	An undefined communications state change command was received.	<ul style="list-style-type: none"> An undefined communications state change command was received 			S			I586
84B40000 hex	Synchronization Error	A signal for synchronous communications could not be detected.	<ul style="list-style-type: none"> Noise Error of the EtherCAT slave communications controller 			S			I586
84B50000 hex	Sync Manager WDT Error	PDO communications were interrupted for the allowable period or longer.	<ul style="list-style-type: none"> An EtherCAT communications cable is disconnected, loose, or broken Host controller error 			S			I586
84B60000 hex	ESC Initialization Error	The initialization of EtherCAT slave communications controller failed.	<ul style="list-style-type: none"> Data was incorrectly overwritten in the non-volatile memory of the EtherCAT slave communications controller Failure of the EtherCAT slave communications controller 			S			I586
84B70000 hex	SII Verification Error	An error occurred in SII data of the EtherCAT slave communications controller.	<ul style="list-style-type: none"> Data was incorrectly overwritten in the non-volatile memory of the EtherCAT slave communications controller Failure of the EtherCAT slave communications controller or false detection 			S			I586

Event code	Event name	Meaning	Assumed cause	Level					Reference
				Maj	Prt	Min	Obs	Info	
84B90000 hex	Synchronization Interruption Error	Synchronization interruption did not occur within the specified period.	<ul style="list-style-type: none"> Incorrect EtherCAT synchronization setting of the host controller Failure of the EtherCAT slave communications controller or false detection 			S			1586
84BA0000 hex	Bootstrap State Transition Request Error	The state transition to unsupported Bootstrap was requested.	<ul style="list-style-type: none"> The EtherCAT master requested the transition of unsupported Bootstrap 			S			1586
88100000 hex	Communications Synchronization Error	Communications were not established consecutively because the synchronization with the EtherCAT Master could not be achieved.	<ul style="list-style-type: none"> The power supply to the host controller was interrupted during PDO communications An EtherCAT communications cable is disconnected, loose, broken, or has a contact failure Noise 			S			1586
88120000 hex	Safety Communications Timeout	A communications timeout occurred in safety process data communications with the Safety CPU Unit.	<ul style="list-style-type: none"> A setting is not correct. The setting of the safety task period of the Safety CPU Unit is too short There is excessive noise The Safety CPU Unit or safety slave entered a status where it could not continue safety process data communications 			S			1586
98200000 hex	Absolute Value Cleared	The multi-rotation counter of the absolute encoder was cleared.	<ul style="list-style-type: none"> The multi-rotation counter of the absolute encoder was cleared 			S			1586
081C0000 hex	Capacitor Lifetime Warning	The capacitor built into the Servo Drive reached the service life.	<ul style="list-style-type: none"> The operating time of the capacitor in the Servo Drive exceeded the service life 				S		1586
081D0000 hex	Inrush Current Prevention Relay Lifetime Warning	The inrush current prevention relay built into the Servo Drive reached the service life.	<ul style="list-style-type: none"> The number of operating times of the inrush current prevention relay in the Servo Drive exceeded the service life 				S		1586
081F0000 hex	Brake Interlock Output Relay Lifetime Warning	The brake interlock output (BKIR) relay built into the Servo Drive reached the service life.	<ul style="list-style-type: none"> The number of operating times of the brake interlock output in the Servo Drive exceeded the service life 				S		1586
083A0000 hex	Encoder Communications Warning	Encoder communications errors occurred in series more frequently than the specified value.	<ul style="list-style-type: none"> Noise into the encoder cable Contact failure of the encoder cable Power supply undervoltage to the encoder 				S		1586
08470000 hex	Encoder Lifetime Warning	The encoder lifetime is close to the end.	<ul style="list-style-type: none"> Temporary noise The end of the encoder life 				S		1586

Event code	Event name	Meaning	Assumed cause	Level					Reference
				Maj	Prt	Min	Obs	Info	
084C0000 hex	Fan Rotation Warning	The rotation speed of the fan is 80% or less of the rating and the cooling performance decreases.	<ul style="list-style-type: none"> There is a foreign matter in the cooling fan and it blocks the rotation Cooling fan failure 				S		I586
084E0000 hex	Absolute Encoder Counter Overflow Warning	The multi-rotation counter of the encoder exceeded the value set in Encoder - Absolute Encoder Counter Overflow Warning Level (4510-02 hex).	<ul style="list-style-type: none"> An inappropriate value was set in the Encoder - Operation Selection when Using Absolute Encoder (4510-01 hex) The multi-rotation number of the encoder exceeded the warning level 				S		I586
18390000 hex	Lifetime Information Corruption Warning	An error was detected in the saved lifetime information.	<ul style="list-style-type: none"> The lifetime information corruption was detected when the power supply was turned ON 				S		I586
34E00000 hex	Data Setting Warning	The object set value is out of the range.	<ul style="list-style-type: none"> The object set value is out of the range 				S		I586
387A0000 hex	Overload Warning	The Load Ratio of Servo Drive or motor (4150-81 hex) exceeded the level set in Overload - Warning Notification Level (4150-01 hex).	<ul style="list-style-type: none"> Operation was continued for a long time with high load. There is incorrect wiring of the motor cable or a broken cable Increase in friction 				S		I586
387D0000 hex	Regeneration Overload Warning	The Regeneration Load Ratio (4150-81 hex) exceeded 85%.	<ul style="list-style-type: none"> The regeneration processing is set inappropriately The Regeneration Resistor is selected inappropriately The Regeneration Resistor is used for continuous regenerative braking The applied power supply voltage is higher than the specified value Regeneration Resistor failure 				S		I586
387E0000 hex	Motor Vibration Warning	The motor vibration, which was higher than or equal to the level set in the Vibration Detection - Detection Level (3B70-01 hex), was detected.	<ul style="list-style-type: none"> The control parameter is set inappropriately The rigidity decreased due to mechanical looseness or wear 				S		I586

Event code	Event name	Meaning	Assumed cause	Level					Reference
				Maj	Prt	Min	Obs	Info	
78220000 hex	Command Warning	A command could not be executed.	<ul style="list-style-type: none"> The <i>Switch ON</i> command was received The <i>Enable operation</i> command was received An operation command in the prohibition direction was received after the immediate stop by the Drive Prohibition Input or Software Position Limit Homing started The positioning start command was received in the Profile position mode 				S		I586
84B00000 hex	EtherCAT Communications Warning	An EtherCAT communications error occurred more than one time.	<ul style="list-style-type: none"> An EtherCAT communications cable has a contact failure, or is connected incorrectly or broken Noise 					S	I586
90A00000 hex	Unit Restarted	Restart was performed.	<ul style="list-style-type: none"> Restart was performed 					S	I586
98210000 hex	STO Detected	The safety input OFF state was detected via the safety input signal or EtherCAT communications.	<ul style="list-style-type: none"> The cable is disconnected or broken The STO input was turned OFF via EtherCAT communications 					S	I586
98220000 hex	Memory All Cleared	The Unit setting was cleared.	<ul style="list-style-type: none"> Clear All Memory was performed 					S	I586
98240000 hex	Event Log Cleared	The event log was cleared.	<ul style="list-style-type: none"> Clear Event Log was performed 					S	I586

Servo G5 (G5-series AC Servo Drives with Built-in EtherCAT Communications) and G5 Linear (G5-series Linear Motors/Drives with Built-in EtherCAT Communications Linear Motor Type)

The manual names are given below for the catalog numbers given in the *Reference* column of the event table.

Cat. No.	Manual name
I576	AC Servomotors/Servo Drives G5-series with Built-in EtherCAT Communications User's Manual
I577	AC Servomotors/Servo Drives G5-series with Built-in EtherCAT Communications Linear Motor Type User's Manual

Event code	Event name	Meaning	Assumed cause	Level					Reference
				Maj	Prt	Min	Obs	Info	
04A80000 hex	Control Power Supply Under-voltage	The voltage between the positive and negative terminals in the control power supply converter dropped below the specified value.	<ul style="list-style-type: none"> Power supply undervoltage. Or, the power supply voltage dropped because there was inrush current when the main power supply was turned ON. A momentary power interruption occurred. The Servo Drive failed. 			S			I576, I577

Event code	Event name	Meaning	Assumed cause	Level					Reference
				Maj	Prt	Min	Obs	Info	
04A90000 hex	Overvoltage	The power supply voltage exceeded the allowable input voltage range.	<ul style="list-style-type: none"> The voltage between the positive and negative terminals in the control power supply converter exceeded the specified value. The voltage was suddenly increased by the phase advance capacitor or the uninterruptible power supply (UPS). The Regeneration Resistor wiring is broken. The External Regeneration Resistor is not suitable. The Servo Drive failed. 			S			I576, I577
04AA0000 hex	Main Circuit Power Supply Undervoltage (Undervoltage between positive and negative terminals)	If the Undervoltage Error Selection (3508 hex) is set to 1, a momentary power interruption occurred between L1 and L3 for longer than the value specified for the Momentary Hold Time. The voltage between the positive and negative terminals in the main power supply converter dropped below the specified value while the Servo was ON.	<ul style="list-style-type: none"> Insufficient power supply capacity The electromagnetic contactor in the main circuit power supply was tripped. A momentary power interruption occurred. A Servo Drive with 3-phase input specifications was operated with a single-phase power supply. The Servo Drive failed. 			S			I576, I577
04AB0000 hex	Main Circuit Power Supply Undervoltage (AC Cutoff Detected)	If the Undervoltage Error Selection (3508 hex) is set to 1, a momentary power interruption occurred between L1 and L3 for longer than the value specified for the Momentary Hold Time. The voltage between the positive and negative terminals in the main power supply converter dropped below the specified value while the Servo was ON.	<ul style="list-style-type: none"> Insufficient power supply capacity The electromagnetic contactor in the main circuit power supply was tripped. A momentary power interruption occurred. A Servo Drive with 3-phase input specifications was operated with a single-phase power supply. The Servo Drive failed. 			S			I576, I577

Event code	Event name	Meaning	Assumed cause	Level					Reference
				Maj	Prt	Min	Obs	Info	
04AC0000 hex	Overcurrent	The current flowing through the converter exceeded the specified value.	<ul style="list-style-type: none"> A short-circuit, line-to-ground fault, contact failure, or insulation failure occurred on the U, V, or W motor line. The Servo Drive failed. The relay for the dynamic brake has been welded due to frequent Servo ON/OFF operations. Motor windings are burned out. The Servomotor is not suitable for the Servo Drive. The command input timing is the same as or earlier than the Servo ON timing. 			S			I576, I577
04AD0000 hex	IPM Error	The current flowing through the converter exceeded the specified value.	<ul style="list-style-type: none"> A short-circuit, line-to-ground fault, contact failure, or insulation failure occurred on the U, V, or W motor line. The Servo Drive failed. The relay for the dynamic brake has been welded due to frequent Servo ON/OFF operations. Motor windings are burned out. The Servomotor is not suitable for the Servo Drive. The pulse input timing is the same as or earlier than the Servo ON timing. 			S			I576, I577
04AE0000 hex	Regeneration Tr Error	The Servo Drive regeneration drive Tr is faulty.	<ul style="list-style-type: none"> The Servo Drive regeneration drive Tr is faulty. 			S			I576, I577
04AF0000 hex	Encoder Phase-Z Error	A missing serial incremental encoder phase-Z pulse was detected.	<ul style="list-style-type: none"> The encoder is faulty. 			S			I576
04B00000 hex	Encoder CTS Signal Error	A missing serial incremental encoder CTS signal logic error was detected.	<ul style="list-style-type: none"> The encoder is faulty. 			S			I576
04B10000 hex	Node Address Setting Error	The node address that was read from the rotary switches was not between 00 and 99.	<ul style="list-style-type: none"> The Servo Drive failed. 			S			I576, I577
04B20000 hex	Other Errors	The Servo Drive malfunctioned, or an error occurred in the Servo Drive.	<ul style="list-style-type: none"> The control circuit malfunctioned temporarily due to excess noise. The Servo Drive's self-diagnosis function detected an error in the Servo Drive. 			S			I577
08080000 hex	Encoder Communications Disconnection Error	A disconnection was detected because communications between the encoder and the Servo Drive were stopped more frequently than the specified value.	<ul style="list-style-type: none"> The encoder is not wired correctly. 			S			I576

Event code	Event name	Meaning	Assumed cause	Level					Reference
				Maj	Prt	Min	Obs	Info	
08090000 hex	Encoder Communications Error	There is a communications error for the encoder.	<ul style="list-style-type: none"> The power supply voltage of the encoder is low. Noise 			S			I576
080A0000 hex	Encoder Communications Data Error	There is an error in the communications data of the encoder.	<ul style="list-style-type: none"> The power supply voltage of the encoder is low. Noise 			S			I576
080B0000 hex	Safety Input Error	At least one of the input photocouplers for safety inputs 1 and 2 turned OFF.	<ul style="list-style-type: none"> The cable is disconnected or broken. 			S			I576, I577
080C0000 hex	External Encoder Connection Error	A disconnection was detected because communications between the external encoder and the Servo Drive were stopped more frequently than the specified value.	<ul style="list-style-type: none"> The wiring is incorrect. 			S			I576, I577
080D0000 hex	External Encoder Communications Data Error	There was a communications error in data from the external encoder.	<ul style="list-style-type: none"> There is insufficient external encoder power supply voltage. Noise 			S			I576, I577
080E0000 hex	External Encoder Status Error 0	Bit 00 of the external encoder error code (ALMC) was set to 1.	<ul style="list-style-type: none"> Bit 00 of the external scale error code (ALMC) was set to 1. 			S			I576, I577
080F0000 hex	External Encoder Status Error 1	Bit 01 of the external encoder error code (ALMC) was set to 1.	<ul style="list-style-type: none"> Bit 01 of the external encoder error code (ALMC) was set to 1. 			S			I576, I577
08100000 hex	External Encoder Status Error 2	Bit 02 of the external encoder error code (ALMC) was set to 1.	<ul style="list-style-type: none"> Bit 02 of the external encoder error code (ALMC) was set to 1. 			S			I576, I577
08110000 hex	External Encoder Status Error 3	Bit 03 of the external encoder error code (ALMC) was set to 1.	<ul style="list-style-type: none"> Bit 03 of the external encoder error code (ALMC) was set to 1. 			S			I576, I577
08120000 hex	External Encoder Status Error 4	Bit 04 of the external encoder error code (ALMC) was set to 1.	<ul style="list-style-type: none"> Bit 04 of the external encoder error code (ALMC) was set to 1. 			S			I576, I577
08130000 hex	External Encoder Status Error 5	Bit 05 of the external encoder error code (ALMC) was set to 1.	<ul style="list-style-type: none"> Bit 05 of the external encoder error code (ALMC) was set to 1. 			S			I576, I577
08140000 hex	Phase-A Connection Error	An error such as broken wiring was detected in the external encoder phase-A connection.	<ul style="list-style-type: none"> An error such as broken wiring was detected in the external encoder phase-A connection. 			S			I576, I577
08150000 hex	Phase-B Connection Error	An error such as broken wiring was detected in the external encoder phase-B connection.	<ul style="list-style-type: none"> An error such as broken wiring was detected in the external encoder phase-B connection. 			S			I576, I577

Event code	Event name	Meaning	Assumed cause	Level					Reference
				Maj	Prt	Min	Obs	Info	
08160000 hex	Phase-Z Connection Error	An error such as broken wiring was detected in the external encoder phase-Z connection.	<ul style="list-style-type: none"> An error such as broken wiring was detected in the external encoder phase-Z connection. 			S			I576, I577
08170000 hex	Encoder Data Restoration Error	Initialization of internal position data was not processed correctly in Semi-closed Control Mode and Absolute Value Mode.	<ul style="list-style-type: none"> There is insufficient power supply voltage for the encoder. Noise is entering on the encoder line. 			S			I576
08180000 hex	External Encoder Data Restoration Error	Initialization of internal position data was not processed correctly in Fully-closed Control Mode and Absolute Value Mode.	<ul style="list-style-type: none"> There is insufficient power supply voltage for the external encoder. Noise is entering on the external encoder line. 			S			I576
14A80000 hex	Object Error	The object area data in non-volatile memory is corrupted.	<ul style="list-style-type: none"> Noise Non-volatile memory failure 			S			I576, I577
14A90000 hex	Object Error	The object area data in non-volatile memory is corrupted.	<ul style="list-style-type: none"> Noise Non-volatile memory failure 			S			I576, I577
14AA0000 hex	Object Error	The object area data in non-volatile memory is corrupted.	<ul style="list-style-type: none"> Noise Non-volatile memory failure 			S			I576, I577
14AB0000 hex	Object Corrupted	The checksum data in non-volatile memory is corrupted.	<ul style="list-style-type: none"> Non-volatile memory failure 			S			I576, I577
14AC0000 hex	Object Corrupted	The checksum data in non-volatile memory is corrupted.	<ul style="list-style-type: none"> Non-volatile memory failure 			S			I576, I577
14AD0000 hex	Object Corrupted	The checksum data in non-volatile memory is corrupted.	<ul style="list-style-type: none"> Non-volatile memory failure 			S			I576, I577
18200000 hex	Absolute Encoder Overspeed Error	The Servomotor rotation speed exceeded the specified value when only the battery power supply was used during a power interruption.	<ul style="list-style-type: none"> There is insufficient power supply voltage for the encoder. The wiring of the CN2 connector is wrong. An external force is rotating the motor when the Servo is OFF. 			S			I576
18210000 hex	Encoder Initialization Error	An encoder initialization error was detected.	<ul style="list-style-type: none"> Servomotor failed. 			S			I576
18220000 hex	Absolute Encoder One-rotation Counter Error	The encoder detected a one-rotation counter error.	<ul style="list-style-type: none"> Servomotor failed. 			S			I576

Event code	Event name	Meaning	Assumed cause	Level					Reference
				Maj	Prt	Min	Obs	Info	
18230000 hex	Absolute Encoder Multi-rotation Counter Error	The encoder detected a multi-rotation counter error.	<ul style="list-style-type: none"> Servomotor failed. 			S			I576
24680000 hex	Motor Non-conformity	The Servo Drive and Servomotor combination is not correct.	<ul style="list-style-type: none"> The Servo Drive and Servomotor combination is not correct. 			S			I576
24690000 hex	Motor Non-conformity	The Servo Drive and Servomotor combination is not correct.	<ul style="list-style-type: none"> The Servo Drive and Servomotor combination is not correct. 			S			I576
246A0000 hex	Motor Non-conformity	The Servo Drive and Servomotor combination is not correct.	<ul style="list-style-type: none"> The Servo Drive and Servomotor combination is not correct. 			S			I576
246B0000 hex	Motor Non-conformity	The Servo Drive and Servomotor combination is not correct.	<ul style="list-style-type: none"> The Servo Drive and Servomotor combination is not correct. 			S			I576
246C0000 hex	Motor Non-conformity	The Servo Drive and Servomotor combination is not correct.	<ul style="list-style-type: none"> The Servo Drive and Servomotor combination is not correct. 			S			I576
28010000 hex	Motor Setting Error	Settings associated with the motor and external encoder are missing.	<ul style="list-style-type: none"> Settings associated with the motor and external encoder are missing. 			S			I577
28020000 hex	Motor Combination Error 1	The value set for the motor current exceeds the maximum motor capacity allowed for the Servo Drive.	<ul style="list-style-type: none"> The Motor Rated Rms Current/Motor Peak Absolute Current exceeds the maximum motor capacity allowed for the Servo Drive. 			S			I577
28030000 hex	Motor Combination Error 2	The value set for the motor exceeds the drive range of the motor.	<ul style="list-style-type: none"> The Motor Rated Rms Current is too low compared with the maximum motor capacity of the Servo Drive. The percentage of the Motor Coil Unit Mass to the Motor Rated Force is too high. The automatically adjusted Current Loop Proportional Gain/Current Loop Integral Gain is too high. The percentage of the Motor Peak Absolute Current to the Motor Rated Rms Current is greater than 500%. 			S			I577
34E10000 hex	Servo Drive Overheat	The temperature of the Servo Drive radiator or power elements exceeded the specified value.	<ul style="list-style-type: none"> The ambient temperature of the Servo Drive exceeded the specified value. Overload 			S			I576, I577

3 Error Tables

Event code	Event name	Meaning	Assumed cause	Level					Reference
				Maj	Prt	Min	Obs	Info	
34E20000 hex	Overload	When the feedback value for torque/force command exceeds the overload level specified in the Overload Detection Level Setting (3512 hex), overload protection is performed according to the overload characteristics.	<ul style="list-style-type: none"> Operation was continued for a long time while overloaded. There is incorrect wiring of the motor line or a broken cable. 			S			I576, I577
34E30000 hex	Regeneration Overload	The regenerative energy exceeds the processing capacity of the Regeneration Resistor.	<ul style="list-style-type: none"> The load inertia/load mass is too large. Or, the Servomotor rotation speed/motor speed is too high to absorb the regenerative energy within the specified deceleration time. This Regeneration Resistor cannot be used for continuous regenerative braking. (The operating limit of the external resistor is limited to a 10% duty.) 			S			I576, I577
34E40000 hex	Error Counter Overflow	Position error pulses exceeded the setting of the Following error window (6065 hex).	<ul style="list-style-type: none"> Motor operation does not follow the command. The value of the Following error window (6065 hex) is small. The encoder/external encoder wiring is incorrect. 			S			I576, I577
34E50000 hex	Excessive Velocity Error	The difference between the internal position command velocity and the actual velocity (i.e., the velocity error) exceeded the Excessive Velocity Error Setting (3602 hex).	<ul style="list-style-type: none"> Motor operation does not follow the command. The setting of the Excessive Velocity Error Setting (3602 hex) is too small. 			S			I576, I577
34E60000 hex	Overspeed	The Servomotor rotation speed/motor speed exceeded the value set on the Overspeed Detection Level Setting (3513 hex).	<ul style="list-style-type: none"> The velocity command value is too large. There is overshooting. The wiring is incorrect. 			S			I576, I577
383F0000 hex	Excessive Hybrid Following Error	During fully-closed control, the difference between the load position from the external encoder and the Servomotor position from the encoder was larger than the number of pulses set as the Hybrid Following Error Counter Overflow Level (3328 hex).	<ul style="list-style-type: none"> Connections are not correct. The settings are not correct. 			S			I576

Event code	Event name	Meaning	Assumed cause	Level					Reference
				Maj	Prt	Min	Obs	Info	
38400000 hex	Overspeed 2	The Servomotor rotation speed/motor speed exceeded the value set on Overspeed Detection Level Setting at Immediate Stop (3615 hex).	<ul style="list-style-type: none"> The velocity command value is too large. There is overshooting. The wiring is incorrect. 			S			1576, 1577
38410000 hex	Command Error	The position command variation after the electronic gear exceeded the specified value.	<ul style="list-style-type: none"> The change in position command is too large. The backlash compensation amount is too large. 			S			1576, 1577
38420000 hex	Command Generation Error	During position command processing, an error such as a calculation range error occurred.	<ul style="list-style-type: none"> During position command processing, an error such as a calculation range error occurred. 			S			1576, 1577
38430000 hex	Error Counter Overflow 1	The absolute encoder position/absolute scale position in pulses divided by the electronic gear ratio exceeded $\pm 2^{31}$ (2,147,483,648).	<ul style="list-style-type: none"> The absolute encoder position/absolute scale position in pulses divided by the electronic gear ratio exceeded $\pm 2^{31}$ (2,147,483,648). 			S			1576, 1577
38440000 hex	Error Counter Overflow 2	The position following error in pulses exceeded $\pm 2^{29}$ (536,870,912). Or, the position following error in command units exceeded $\pm 2^{30}$ (1,073,741,824).	<ul style="list-style-type: none"> There is insufficient torque/force. There is insufficient gain. The encoder/external encoder wiring is incorrect. 			S			1576, 1577
38450000 hex	Interface Input Duplicate Allocation Error 1	There is a duplicate setting in the input signal (IN1, IN2, IN3, and IN4) function allocations.	<ul style="list-style-type: none"> There is a duplicate setting in the input signal (IN1, IN2, IN3, and IN4) function allocations. 			S			1576, 1577
38460000 hex	Interface Input Duplicate Allocation Error 2	There is a duplicate setting in the input signal (IN5, IN6, IN7, and IN8) function allocations.	<ul style="list-style-type: none"> There is a duplicate setting in the input signal (IN5, IN6, IN7, and IN8) function allocations. 			S			1576, 1577
38470000 hex	Interface Input Function Number Error 1	There is an undefined number specification in the input signal (IN1, IN2, IN3, and IN4) function allocations. Or, a logic setting error was detected.	<ul style="list-style-type: none"> There is an undefined number specification in the input signal (IN1, IN2, IN3, and IN4) function allocations. Different logic is set for the same function in the function assignments of the input signals (IN1, IN2, IN3, and IN4). 			S			1576, 1577
38480000 hex	Interface Input Function Number Error 2	There is an undefined number specification in the input signal (IN5, IN6, IN7, and IN8) function allocations. Or, a logic setting error was detected.	<ul style="list-style-type: none"> There is an undefined number specification in the input signal (IN5, IN6, IN7, and IN8) function allocations. Different logic is set for the same function in the function assignments of the input signals (IN5, IN6, IN7, and IN8). 			S			1576, 1577

Event code	Event name	Meaning	Assumed cause	Level					Reference
				Maj	Prt	Min	Obs	Info	
38490000 hex	Interface Output Function Number Error 1	There is an undefined number specification in the output signal (OUTM1) function allocation.	<ul style="list-style-type: none"> There is an undefined number specification in the output signal (OUTM1) function allocation. 			S			I576, I577
384A0000 hex	Interface Output Function Number Error 2	There is an undefined number specification in the output signal (OUTM2) function allocation.	<ul style="list-style-type: none"> There is an undefined number specification in the output signal (OUTM2) function allocation. 			S			I576, I577
384B0000 hex	External Latch Input Allocation Error	There is an error in the latch input function allocation.	<ul style="list-style-type: none"> The latch input was allocated to an input signal other than IN5, IN6, or IN7. A latch input is assigned to an NC signal. The same latch input is not assigned to the same pin in all Control Modes. 			S			I576, I577
384C0000 hex	Overrun Limit Error	The Servomotor exceeded the allowable operating range set in the Overrun Limit Setting (3514 hex) with respect to the position command input range.	<ul style="list-style-type: none"> The gain or inertial ratio/mass ratio is not suitable. The set value of the Overrun Limit Setting (3514 hex) is too small. 			S			I576, I577
384D0000 hex	Absolute Encoder System Down Error	The voltage of the built-in capacitor dropped below the specified value because the power supply to the encoder or the battery power supply was down.	<ul style="list-style-type: none"> The voltage of the built-in capacitor dropped below the specified value because the power supply to the encoder or the battery power supply was down. 			S			I576
384E0000 hex	Absolute Encoder Counter Overflow Error	The multi-rotation counter of the encoder exceeded the specified value.	<ul style="list-style-type: none"> The set value for switching operation with the absolute encoder is too large. The traveling distance from home of the machine exceeded 32,767 revolutions. 			S			I576
384F0000 hex	Object Setting Error 1	The electronic gear ratio exceeded the allowable range.	<ul style="list-style-type: none"> The electronic gear ratio exceeded the allowable range. 			S			I576, I577
38500000 hex	Object Setting Error 2	External encoder ratio exceeded the allowable range.	<ul style="list-style-type: none"> External encoder ratio exceeded the allowable range. 			S			I576, I577
38510000 hex	External Encoder Connection Error	The set value of the External Feedback Pulse Type Selection (3323 hex) differs from the external encoder type that is connected for serial communications.	<ul style="list-style-type: none"> The set value of the External Feedback Pulse Type Selection (3323 hex) differs from the external encoder type that is connected for serial communications. 			S			I576, I577

Event code	Event name	Meaning	Assumed cause	Level					Reference
				Maj	Prt	Min	Obs	Info	
38520000 hex	Function Setting Error	The function that was set does not support the communications period.	<ul style="list-style-type: none"> The electronic gear object ratio was not 1:1 when the communications period was set to 500 μs. Modes of operation (6060 hex) was set to pp or hm when the communications period was set to 500 μs. More than 12 bytes were mapped for RxPDO in Fully-closed Control Mode (This applies only to Cylinder-type Servomotors.). Modes of operation (6060 hex) was set to pp or hm in Fully-closed Control Mode when the communications period was set to 1 ms and the electronic gear parameter ratio was not set to 1:1 (This applies only to Cylinder-type Servomotors.). No bytes (i.e., no objects) were mapped for RxPDO. More than 10 objects were mapped for RxPDO. More than 11 objects were mapped for TxPDO. CSP Switching Reference Position (4020 hex) was mapped for TxPDO when the communications period was set to 500 μs or when the electronic gear object ratio was not set to 1:1. 			S			1576, 1577
38530000 hex	Magnetic Pole Position Estimation Error 1	Magnetic pole position estimation was not completed successfully.	<ul style="list-style-type: none"> Settings associated with the external encoder are incorrect. The command time or force command value for magnetic pole position estimation is too low. There is a large unbalanced load or friction. 			S			1577
38540000 hex	Magnetic Pole Position Estimation Error 2	Magnetic pole position estimation was not completed successfully because the motor did not stop within the Magnetic Pole Position Estimation Time Limit for Stop.	<ul style="list-style-type: none"> The value set for the Magnetic Pole Position Estimation Time Limit for Stop (3927 hex) is small compared with the actual stop time of the motor. The motor is moving when no force is applied. 			S			1577
38550000 hex	Magnetic Pole Position Estimation Error 3	Magnetic pole position restoration was not completed successfully.	<ul style="list-style-type: none"> The Magnetic Pole Detection Method (3920 hex) object was set to 3 (Magnetic pole position restoration method), although magnetic pole position estimation had never been executed. The Magnetic Pole Detection Method (3920 hex) was set to 3 (Magnetic pole position restoration method) when a non-absolute type external encoder was used. 			S			1577

Event code	Event name	Meaning	Assumed cause	Level					Reference
				Maj	Prt	Min	Obs	Info	
38560000 hex	Motor Auto-setting Error	The current exceeded the limit when it was applied to the Motor when the Servo was locked or when FFT measurement preparations were performed.	<ul style="list-style-type: none"> The Current Loop Proportional Gain or the Current Loop Integral Gain was too large before auto-setting was performed. 			S			I577
64E00000 hex	Drive Prohibition Input Error 1	When the Drive Prohibition Input Selection (3504 hex) was set to 0, both the Forward/Positive Drive Prohibition Input (POT) and Reverse/Negative Drive Prohibition Input (NOT) turned ON. Or, when the Drive Prohibition Input Selection (3504 hex) was set to 2, either the Forward/Positive Drive Prohibition Input (POT) or Reverse/Negative Drive Prohibition Input (NOT) turned ON.	<ul style="list-style-type: none"> A problem occurred with the switches, wires, and power supplies that are connected to the Forward/Positive Drive Prohibition Input (POT) and Reverse/Negative Drive Prohibition Input (NOT). 			S			I576, I577
64E10000 hex	Drive Prohibition Input Error 2	An operation command (such as a trial run of FFT) was received from the CX-Drive when the Drive Prohibition Input Selection (3504 hex) was set to 0, EtherCAT communications was interrupted, and either POT or NOT was ON. Or, POT or NOT turned ON while operation was being performed for a CX-Drive operation command.	<ul style="list-style-type: none"> A problem occurred with the switches, wires, and power supplies that are connected to the Forward/Positive Drive Prohibition Input (POT) and Reverse/Negative Drive Prohibition Input (NOT). 			S			I576, I577
64E20000 hex	Immediate Stop Input Error	An Immediate Stop (STOP) signal was input.	<ul style="list-style-type: none"> An Immediate Stop (STOP) signal was input. Incorrect wiring of the immediate stop input (STOP). 			S			I576, I577

Event code	Event name	Meaning	Assumed cause	Level					Reference
				Maj	Prt	Min	Obs	Info	
74810000 hex	Command Error	A mistake was made in using a command.	<ul style="list-style-type: none"> When bit 09 (Remote) of the Statusword (6041 hex) was set to 1 (remote), and the Servo Drive was in operation enabled state (Servo ON), a command was received that changes the communications state from Operational to another state (Init, Pre-operational, or Safe-operational state). When bit 09 (Remote) of the Statusword (6041 hex) was set to 0 (local), a command was received during FFT or test run status that changes the ESM state from Operational, Safe-operational, or Pre-operational state to Init state. An unsupported number was set for 6060 hex (Operation Mode). During Fully-closed Control Mode, csv or cst was set for 6060 hex (Operation Mode) (This applies to Cylinder-type Servomotors.). The setting of 6060 hex (Operation Mode) was changed at an interval of less than 2 ms. Homing was started when 6098 hex (Homing Method) was set to a value other than 8, 12, 19, 20, 33, 34, or 35. Data setting warnings (B0 hex) occurred continuously for the number of data setting warnings that is set in 3781 hex (Data Setting Warning Detection Count). 			S			I576, I577
78010000 hex	Operation Command Competition	An attempt was made to establish EtherCAT communications or to turn ON the Servo from the Controller (enable operation) while executing an FFT that operates with the Servo Drive alone or a trial run.	<ul style="list-style-type: none"> EtherCAT communications (change from Init to Pre-operational state) was established or an attempt to turn ON the Servo from the Controller (enable operation) was made while executing an FFT that operates with the Servo Drive trial run. 			S			I576, I577
78020000 hex	Absolute Encoder Status Error	The rotation of the encoder was higher than the specified value when the power supply was turned ON.	<ul style="list-style-type: none"> The rotation of the encoder was higher than the specified value when the power supply was turned ON. 			S			I576
84B10000 hex	EtherCAT State Change Error	A communications state change command was received for which the current communications state could not be changed.	<ul style="list-style-type: none"> A communications state change command was received for which the current communications state could not be changed. 			S			I576, I577

Event code	Event name	Meaning	Assumed cause	Level					Reference
				Maj	Prt	Min	Obs	Info	
84B20000 hex	EtherCAT Illegal State Change Error	An undefined communications state change command was received.	<ul style="list-style-type: none"> An undefined communications state change command was received. 			S			I576, I577
84B30000 hex	Communications Synchronization Error	The number of consecutive errors in receiving data during the communication sync time exceeded the value specified for the Communications Error Setting (2200 hex).	<ul style="list-style-type: none"> Power to the host controller was interrupted during PDO communications. An EtherCAT communications cable is disconnected, broken, or incorrectly connected. Noise 			S			I576, I577
84B40000 hex	Synchronization Error	A synchronization error occurred.	<ul style="list-style-type: none"> Noise Control PCB error 			S			I576, I577
84B50000 hex	Sync Manager WDT Error	PDO communications were stopped for more than the specified period of time.	<ul style="list-style-type: none"> The EtherCAT communications cable is disconnected or broken. There is an error in the host controller. 			S			I576, I577
84B60000 hex	ESC Initialization Error	An error occurred in ESC initialization.	<ul style="list-style-type: none"> Control PCB error 			S			I576, I577
84B70000 hex	Slave Unit Verification Error	An error occurred in Slave Unit verification.	<ul style="list-style-type: none"> Control PCB error 			S			I576, I577
84B80000 hex	Communications Setting Error	There is an error in the communications settings.	<ul style="list-style-type: none"> An out-of-range value was set from the host controller. A command that changes the communications state to an unsupported state was received. 			S			I576, I577
84B90000 hex	Synchronization Interruption Error	A synchronization interruption error occurred.	<ul style="list-style-type: none"> Control PCB error 			S			I576, I577
98010000 hex	Absolute Value Cleared	The multi-rotation counter for the absolute encoder was cleared during USB communications by the CX-Drive.	<ul style="list-style-type: none"> The multi-rotation counter for the absolute encoder was cleared during USB communications by the CX-Drive. 			S			I576
98020000 hex	Position Data Initialized	A Config operation was performed or the multi-rotation counter was cleared for the absolute encoder during EtherCAT communications.	<ul style="list-style-type: none"> A Config operation was performed during EtherCAT communications. The multi-rotation counter was cleared for the absolute encoder. (This applies only to Cylinder-type Servomotors.) 			S			I576, I577
08010000 hex	Battery Warning	The battery voltage is 3.2 V or less.	<ul style="list-style-type: none"> The battery voltage is 3.2 V or lower. 				S		I576
08020000 hex	Fan Warning	The fan stop state continued for 1 second.	<ul style="list-style-type: none"> There is foreign matter in the fan. The Servo Drive failed. 				S		I576, I577
08030000 hex	Encoder Communications Warning	Encoder communications errors occurred in series more frequently than the specified value.	<ul style="list-style-type: none"> There is insufficient power supply voltage for the encoder. Noise is entering on the encoder line. 				S		I576

Event code	Event name	Meaning	Assumed cause	Level					Reference
				Maj	Prt	Min	Obs	Info	
08040000 hex	Encoder/Serial Conversion Unit Overheating Warning	The encoder temperature exceeded the specified value or an overheating warning was detected for the Serial Conversion Unit.	<ul style="list-style-type: none"> The ambient temperature is too high. Servomotor/Linear Motor failed. 				S		I576, I577
08050000 hex	Life Expectancy Warning	The remaining life of the capacitor or the fan is shorter than the specified value.	<ul style="list-style-type: none"> The life expectancy of the capacitor or the fan is shorter than the specified value. 				S		I576, I577
08060000 hex	External Encoder Error Warning	The external encoder detected a warning.	<ul style="list-style-type: none"> There is insufficient power supply voltage for the external encoder. Noise is entering on the external encoder connector cable. The external encoder failed. 				S		I576, I577
08070000 hex	External Encoder Communications Warning	The external encoder had more communications errors than the specified value.	<ul style="list-style-type: none"> There is insufficient power supply voltage for the external encoder. Noise is entering on the external encoder connector cable. 				S		I576, I577
34E00000 hex	Data Setting Warning	An object setting is out of range.	<ul style="list-style-type: none"> An object setting is out of range. 				S		I576, I577
383C0000 hex	Overload Warning	The load ratio is 85% or more of the protection level.	<ul style="list-style-type: none"> Overload There is incorrect wiring of the motor line or a broken cable. 				S		I576, I577
383D0000 hex	Excessive Regeneration Warning	The regeneration load ratio is 85% or more of the level.	<ul style="list-style-type: none"> There is excessive regeneration. This Regeneration Resistor cannot be used for continuous regenerative braking. 				S		I576, I577
383E0000 hex	Vibration Detection Warning	Vibration was detected.	<ul style="list-style-type: none"> The gain or inertial ratio/mass ratio setting is not suitable. 				S		I576, I577

Event code	Event name	Meaning	Assumed cause	Level					Reference
				Maj	Prt	Min	Obs	Info	
74800000 hex	Command Warning	A command could not be executed.	<ul style="list-style-type: none"> The absolute multi-rotation counter was cleared when the Servo was not OFF when using an absolute encoder for semi-closed control (This applies only to Cylinder-type Servomotors.). A forced brake operation request was sent while the Servo was ON. A Switch ON command was sent when the main power was OFF. (When 3508 hex = 0) An Enable Operation command was sent to request turning ON the Servo when the Servomotor was operating at 30 r/min or 30 mm/s, or higher. A latch operation was started under the following conditions. <ul style="list-style-type: none"> An absolute external encoder was used and phase Z was selected as the trigger for fully-closed control (This applies only to Cylinder-type Servomotors.). The absolute multi-rotation data was being cleared or the Config operation was being performed. The Statusword (6041 hex) bit 09 (remote) was 0 (local). An operation command is given in the prohibited direction after the motor made an immediate stop due to a drive prohibition input. 				S		I576, I577
84B00000 hex	EtherCAT Communications Warning	An EtherCAT communications error occurred one or more times.	<ul style="list-style-type: none"> The EtherCAT communications cable is disconnected or broken. Noise 				S		I576, I577

MX2/RX-series Inverters with EtherCAT Communications Units

The manual names are given below for the catalog numbers given in the *Reference* column of the event table.

Cat. No.	Manual name
I574	MX2/RX Series Inverter EtherCAT Communication Unit User's Manual

Event code	Event name	Meaning	Assumed cause	Level					Reference
				Maj	Prt	Min	Obs	Info	
04A10000 hex	Non-volatile Memory Hardware Error	An error occurred in non-volatile memory.	<ul style="list-style-type: none"> Non-volatile memory failure 			S			I574

Event code	Event name	Meaning	Assumed cause	Level					Reference
				Maj	Prt	Min	Obs	Info	
04BA0000 hex	Connection Error between Inverter and Communications Unit	An error occurred in the connection between the Inverter and the EtherCAT Communications Unit for the Inverter.	<ul style="list-style-type: none"> Contact failure between the Inverter and the EtherCAT Communications Unit for the Inverter. Inverter trip was reset. The Inverter was initialized or the mode was changed. The EtherCAT Communications Unit for the Inverter failed. 			S			I574
04BB0000 hex	Inverter Warning	An Inverter warning was detected.	<ul style="list-style-type: none"> An Inverter warning was detected. 			S			I574
04BC0000 hex	Inverter Trip	An Inverter trip was detected.	<ul style="list-style-type: none"> An Inverter trip was detected. 			S			I574
34F00000 hex	PDO Setting Error	There is an illegal setting value in the PDO mapping.	<ul style="list-style-type: none"> The PDO mapping or Sync-Manager settings are incorrect. 			S			I574

FH-series Vision Systems

The manual names are given below for the catalog numbers given in the *Reference* column of the event table.

Cat. No.	Manual name
Z342	FH/FZ5 Vision System FH/FZ5 Series User's Manual for Communications Settings

Event code	Event name	Meaning	Assumed cause	Level					Reference
				Maj	Prt	Min	Obs	Info	
08210000 hex	Fan/Power Supply Error	An error occurred in the fan or power supply.	<ul style="list-style-type: none"> A foreign object is interfering with fan operation. A suitable power supply voltage is not being used, resulting in an overvoltage or undervoltage. 			S			Z342
08220000 hex	Camera Overcurrent Detected	An overcurrent flowed to the Camera.	<ul style="list-style-type: none"> There is a short circuit inside the Camera cable or in a circuit inside the Controller. 			S			Z342
08230000 hex	Parallel I/O Overcurrent Detected	An overcurrent occurred in the parallel I/O interface.	<ul style="list-style-type: none"> A parallel I/O interface line is short-circuited. 			S			Z342
182D0000 hex	Setting Data Load Error	Loading the scene group data failed.	<ul style="list-style-type: none"> The data is corrupted because the power supply was turned OFF while saving the previous scene data. As the result of changing the operation mode, the required amount of memory increased, resulting in insufficient memory. 						Z342
38590000 hex	Camera Connection Error	The Camera connection is wrong.	<ul style="list-style-type: none"> A Camera is not connected to the Controller. The Camera cable is broken. The Camera Selection settings are not correct in the Camera Image Input and Camera Switching processing items. A Camera is not connected to the Camera port on the Controller according to the Camera Selection settings in the Camera Image Input and Camera Switching processing items. 			S			Z342

Event code	Event name	Meaning	Assumed cause	Level					Reference
				Maj	Prt	Min	Obs	Info	
385A0000 hex	Change in Connected Camera	The Camera that is connected is different from when data was last saved.	<ul style="list-style-type: none"> The Camera connection information in the scene data does not agree with the connection information for the Camera connected to the Controller. 			S			Z342
385B0000 hex	Light installation error	The Light installation is incorrect.	<ul style="list-style-type: none"> The power consumption of the light installed onto a camera with a Lighting Controller is incorrect. The lighting mode of the light installed onto a camera with a Lighting Controller is incorrect. No external power supply is connected to the camera with a Lighting Controller. 			S			Z342
48020000 hex	System Error	An error occurred in the system.	<ul style="list-style-type: none"> A serious error occurred in the system in the Controller. 			S			Z342
58210000 hex	Output Control Timeout for Parallel I/O, PLC Link, or EtherNet/IP	A timeout occurred in data output handshaking control for measurement results.	<ul style="list-style-type: none"> The data output handshaking controls in the program (i.e., the ON/OFF timing of the DSA signal) are not correct. The output control timeout time is too short in comparison with the program processing time. The parallel I/O DSA or Result Notification signal is not wired correctly. 			S			Z342
58220000 hex	Output Control Timeout for EtherCAT	A timeout occurred in data output handshaking control for measurement results.	<ul style="list-style-type: none"> The data output handshaking controls in the program (i.e., the ON/OFF timing of the Result Set Request signal) are not correct. The output control timeout time is too short in comparison with the program processing time. 			S			Z342
58230000 hex	Initial scene group error	Initial scene group setting is incorrect.	<ul style="list-style-type: none"> The external storage specified as the scene group destination by the Scene Group Saving Destination Settings tool is not connected at the time of startup. The destination directory is not detected at the time of startup. Initial scene group number is not within the range of scene group accepted by the system. 			S			Z342
58240000 hex	Initial scene number error	Initial scene number setting is incorrect.	<ul style="list-style-type: none"> Initial scene number is not within the range of scenes accepted by the system. 			S			Z342
78190000 hex	Image Logging Disk Write Error	Writing data to the image logging disk failed.	<ul style="list-style-type: none"> A logging disk is not inserted. The available space on the logging disk is not sufficient. There is no logging folder. Security restrictions are set on the logging disk. 			S			Z342

Event code	Event name	Meaning	Assumed cause	Level					Reference
				Maj	Prt	Min	Obs	Info	
781A0000 hex	Setting Data Transfer Error	An error occurred while transferring the scene data.	<ul style="list-style-type: none"> Scene data was edited when there was little available space on the RAM disk and the operation mode was Double Speed Multiinput. The data transfer button was clicked when there was little available space on the RAM disk and the operation mode was Non-stop Adjustment Mode. 			S			Z342
781B0000 hex	Output Buffer Error (EtherCAT)	The data output buffer for measurement data is full.	<ul style="list-style-type: none"> Data measurements are being performed on a period that is shorter than the time that is required for data output handshake controls in the program. 			S			Z342
88080000 hex	PLC Link Communications Error	A PLC Link cannot be established.	<ul style="list-style-type: none"> There is a mistake in the PLC or Vision Sensor communications settings. The Ethernet or RS-232C cable is damaged. 			S			Z342

EtherCAT FQ-M-series Specialized Vision Sensors for Positioning

The manual names are given below for the catalog numbers given in the *Reference* column of the event table.

Cat. No.	Manual name
Z314	FQ-M-series Specialized Vision Sensor for Positioning User's Manual

Event code	Event name	Meaning	Assumed cause	Level					Reference
				Maj	Prt	Min	Obs	Info	
78080000 hex	TRIG Input Error	A TRIG signal was input when the BUSY signal for Sensor measurement was ON.	<ul style="list-style-type: none"> A TRIG signal was input when the BUSY signal for Sensor measurement was ON. Chattering occurred for a contact input. 			S			Z314
780A0000 hex	Scene Data Error	The scene data to switch to is corrupted.	<ul style="list-style-type: none"> The power supply was interrupted when the scene data to switch to was saved. 			S			Z314
780B0000 hex	Model Error	A model was re-registered with an image with low contrast.	<ul style="list-style-type: none"> A model was re-registered with an image with low contrast. 			S			Z314
780C0000 hex	Logging Error	Some data was not saved when logging data to files on an SD card.	<ul style="list-style-type: none"> Too much data to log in files occurred in a short period of time, and writing to the SD card could not keep up. 			S			Z314
780D0000 hex	Output Timeout	A timeout occurred in data output handshaking control for measurement results.	<ul style="list-style-type: none"> The data output handshaking controls in the program (i.e., the ON/OFF timing of the DSA signal) are not correct. The output control timeout time is too short in comparison with the program processing time. 			S			Z314
780E0000 hex	Output Size Error	The data output size setting and the PDO mapping setting do not agree.	<ul style="list-style-type: none"> The EtherCAT data output size setting in the Sensor and the PDO mapping setting in the EtherCAT master do not agree. 			S			Z314

E3X-series Fiber Sensors with EtherCAT Communications Unit for Digital Sensors

The manual names are given below for the catalog numbers given in the *Reference* column of the event table.

Cat. No.	Manual name
E413	EtherCAT Digital-type Sensor Communication Unit Operation Manual

Event code	Event name	Meaning	Assumed cause	Level					Reference
				Maj	Prt	Min	Obs	Info	
04C40000 hex	Sensor Communications Error	An error occurred in a Sensor connection.	<ul style="list-style-type: none"> The Sensor is disconnected. 			S			E413
04C50000 hex	Sensor Communications Has Not Been Established	Communications has not been established with the Sensor.	<ul style="list-style-type: none"> A Sensor is not connected. 			S			E413
14A00000 hex	Non-volatile Memory Checksum Error	An error occurred in the control parameters.	<ul style="list-style-type: none"> Noise 			S			E413
24780000 hex	Number of Sensors Verify Error	The number of Sensors that is connected does not agree with the settings.	<ul style="list-style-type: none"> The set value does not match the number of Sensors that are actually connected. 			S			E413
24790000 hex	Number of Sensors Over Limit	Too many Sensors are connected.	<ul style="list-style-type: none"> More than the maximum number of Sensors are connected. 			S			E413
34F80000 hex	Dummy Sensors Setting Error	Too many Dummy Units are set.	<ul style="list-style-type: none"> There are too many Dummy Units set, so some Sensors are not assigned logical unit numbers. 			S			E413
04A10000 hex	Non-volatile Memory Hardware Error	An error occurred in non-volatile memory.	<ul style="list-style-type: none"> Non-volatile memory failure 				S		E413

E3NW-ECT EtherCAT Digital Sensor Communications Unit

The manual names are given below for the catalog numbers given in the *Reference* column of the event table.

Cat. No.	Manual name
E429	E3NW-ECT EtherCAT Digital Sensor Communications Unit Operation Manual

Event code	Event name	Meaning	Assumed cause	Level					Reference
				Maj	Prt	Min	Obs	Info	
04C4 0000 hex	Sensor Communications Error	An error occurred in a Sensor connection.	• The Sensor is disconnected.			S			E429
04C5 0000 hex	Sensor Communications Has Not Been Established	Communications has not been established with the Sensor.	• A sensor is not connected.			S			E429
14A0 0000 hex	Non-volatile Memory Checksum Error	An error occurred in the control parameters.	• Noise			S			E429
247A 0000 hex	Number of Distributed Sensor Unit Verify Error	The number of Distributed Sensor Unit that is checked at power up is decreased.	• The Distributed Sensor Unit is disconnected			S			E429
247B 0000 hex	Number of Sensors Over Limit	Too many Sensors are connected.	• More than the maximum number of Sensors are connected.			S			E429
247C 0000 hex	Number of Sensors Verify Error	The number of Sensors that is connected does not agree with the settings.	• The set value does not match the number of Sensors that are actually connected			S			E429
247D 0000 hex	Number of Sensors Over at Distributed Sensor Unit	Too many Sensors are connected at Distributed Sensor Unit.	• More than the maximum number of Sensors are connected at Distributed Sensor Unit.			S			E429
34F8 0000 hex	Dummy Sensors Setting Error	Too many Dummy Units are set.	• There are too many Dummy Units set, so some Sensors are not assigned logical unit numbers.			S			E429
04A1 0000 hex	Non-volatile Memory Hardware Error	An error occurred in non-volatile memory.	• Non-volatile memory failure				S		E429

ZW-CE1□T Confocal Fiber Type Displacement Sensor

The manual names are given below for the catalog numbers given in the *Reference* column of the event table.

Cat. No.	Manual name
Z332	ZW-CE1□T Confocal Fiber Type Displacement Sensor User's Manual

Event code	Event name	Meaning	Assumed cause	Level					Reference
				Maj	Prt	Min	Obs	Info	
04D00000 hex	Hardware error	Some abnormality occurred on the displacement sensor hardware.	<ul style="list-style-type: none"> Hardware damage 			S			Z332
14B00000 hex	Linearity correction data error	The linearity correction data of the displacement sensor is damaged.	<ul style="list-style-type: none"> Calibration ROM damage 			S			Z332
14B10000 hex	Linearity correction data read error	Reading of the displacement sensor linearity correction data was not executed correctly.	<ul style="list-style-type: none"> Calibration ROM not inserted Calibration ROM damage 			S			Z332
14B20000 hex	System setting error	The system settings saved to the displacement sensor are corrupt.	<ul style="list-style-type: none"> The displacement sensor power was turned OFF during saving/loading of system settings. 			S			Z332
14B30000 hex	Bank data error	The bank data saved to the displacement sensor is corrupt.	<ul style="list-style-type: none"> The displacement sensor power was turned OFF during saving/loading of bank data. 			S			Z332
24810000 hex	Ethernet communication parameter error	An invalid IP address is set for the displacement sensor.	<ul style="list-style-type: none"> Invalid IP address setting 			S			Z332
74900000 hex	Multiple control signal input error	Multiple control signals turned ON in the same cycle.	<ul style="list-style-type: none"> Multiple control signals turned ON in the same cycle. 			S			Z332
74910000 hex	EXE input error	EXE input processing was not executed correctly.	<ul style="list-style-type: none"> EXE input turned ON in the FUN mode. EXE input turned ON with READY output OFF. 			S			Z332
74920000 hex	SYNC input error	SYNC input processing was not executed correctly.	<ul style="list-style-type: none"> SYNC input turned ON in the FUN mode. 			S			Z332
74930000 hex	TIMING input error	TIMING input processing was not executed correctly.	<ul style="list-style-type: none"> TIMINGx input turned ON in the FUN mode. TIMINGx input turned ON or OFF while RESETx input was ON. TIMINGx input turned ON in a non-measurement state. TIMINGx input turned ON before the "delay time + sampling time" elapsed. 			S			Z332
74940000 hex	RESET input error	RESET input processing was not executed correctly.	<ul style="list-style-type: none"> RESETx input turned ON in the FUN mode. 			S			Z332
74950000 hex	ZERO input error	ZERO input processing was not executed correctly.	<ul style="list-style-type: none"> ZEROx input turned ON in the FUN mode. ZEROx input turned ON in a non-measurement state. ZEROx input turned ON for a task whose status is OFF. 			S			Z332
74960000 hex	ZEROCLR input error	ZEROCLR input processing was not executed correctly.	<ul style="list-style-type: none"> ZEROCLRx input turned ON in the FUN mode. 			S			Z332

3-1-14 Errors in CJ-series Units

The section provides tables of the errors (events) that can occur in the following CJ-series Units.

- Analog I/O Units
- Process I/O Units
- Temperature Control Units
- ID Sensor Units
- High-speed Counter Units
- Serial Communications Units
- DeviceNet Units
- EtherNet/IP Units
- CompoNet Master Units

CJ-series Analog I/O Units

The section provides tables of the errors (events) that can occur in the following Units.

CJ1W-AD041-V1/AD081-V1

CJ1W-AD042

CJ1W-DA021/DA041

CJ1W-DA08V/DA08C

CJ1W-DA042V

CJ1W-MAD42

The manual names are given below for the catalog numbers given in the *Reference* column of the event table.

Cat. No.	Manual name
W490	CJ-series Analog I/O Units Operation Manual for NJ-series CPU Unit

Event code	Event name	Meaning	Assumed cause	Level					Reference
				Maj	Prt	Min	Obs	Info	
04600000 hex	A/D Conversion Error	An error occurred in A/D conversion.	<ul style="list-style-type: none"> • There is a source of noise nearby. • A/D converter failed. 			S	U		W490
04620000 hex	Non-volatile Memory Error	An error occurred in non-volatile memory.	<ul style="list-style-type: none"> • There is a source of noise nearby. • Non-volatile memory failed. 			S			W490
34800000 hex	Mean Value Processing Setting Error	There is a mistake in the setting of the number of samplings for mean value processing.	<ul style="list-style-type: none"> • There is a mistake in the setting of the number of samplings for mean value processing. 			S			W490
34830000 hex	Scaling Data Setting Error	There is a mistake in the scaling data settings.	<ul style="list-style-type: none"> • The upper or lower limit data for scaling is outside the setting range. Or, the maximum value and minimum value are not 0 and they are the same. 			S			W490
34840000 hex	Input Signal Range Setting Error or Error in Number of Inputs Setting	There is a mistake in the input signal range setting or in the number of inputs setting.	<ul style="list-style-type: none"> • The settings of the input signal range or the setting of the number of analog inputs that are used is incorrect. 			S			W490

Event code	Event name	Meaning	Assumed cause	Level					Reference
				Maj	Prt	Min	Obs	Info	
34850000 hex	Mean Value Processing Setting Error	There is a mistake in the setting of the number of samplings for mean value processing.	<ul style="list-style-type: none"> There is a mistake in the setting of the number of samplings for mean value processing. 			S			W490
34860000 hex	Error in Setting of Conversion Mode	There is a mistake in the Conversion Mode setting.	<ul style="list-style-type: none"> The specification of the Cyclic Conversion Mode or Direct Conversion Mode is not correct. 			S			W490
34870000 hex	Output Hold Setting Error	There is a mistake in the output hold setting.	<ul style="list-style-type: none"> The setting for output status when conversion stops is incorrect. 			S			W490
34890000 hex	Conversion Time/Resolution or Operation Mode Setting Error	There is a mistake in the conversion time/resolution or operation mode setting.	<ul style="list-style-type: none"> There is a mistake in the conversion time/resolution or operation mode setting. 			S			W490
348A0000 hex	Output Signal Range Setting Error or Error In Number of Outputs Used Setting	There is a mistake in the output signal range setting or in the number of outputs setting.	<ul style="list-style-type: none"> There is a mistake in the output signal range setting or in the number of outputs setting. 			S			W490
38010000 hex	Scaling Data Setting Error/Ratio Conversion Use Setting Error	There is an error in the scaling data setting or ratio conversion use setting.	<ul style="list-style-type: none"> The upper or lower limit data for scaling is outside the setting range. Or, the maximum value and minimum value are not 0 and they are the same. The I/O number for ratio conversion is set to <i>Not used</i> in the I/O specifications. 			S			W490
38020000 hex	Ratio Set Value Error	There is a mistake in the ratio setting for ratio conversion.	<ul style="list-style-type: none"> A value other than 16#0000 to 16#9999 (0.00 to 99.99) was specified for the ratio conversion A constant for ratio conversion. 			S			W490
64780000 hex	Input Disconnection Detected	The input is disconnected.	<ul style="list-style-type: none"> Input wiring is broken. Input wiring disconnection 			S	U		W490
64790000 hex	Output Set Value Error	The output setting is out of range.	<ul style="list-style-type: none"> An output set value setting is out of range. 			S	U		W490
34810000 hex	Input Value Exceeded Adjustment Range in Adjustment Mode	In Adjustment Mode, the input value exceeded the range for which adjustment is possible.	<ul style="list-style-type: none"> In Adjustment Mode, the input value exceeded the range for which adjustment is possible, so the offset and gain cannot be adjusted. 			U	S		W490
34820000 hex	Input Number Specification Error in Adjustment Mode	The input number specified in Adjustment Mode is not enabled or the input number is wrong.	<ul style="list-style-type: none"> The input number that was specified in Adjustment Mode is not enabled. The setting of the Adjustment Input Number (device variable <i>*_AdjCh</i>) is incorrect, so adjustment is not possible. 			U	S		W490
34880000 hex	Output Number Specification Error in Adjustment Mode	The output number specified in Adjustment Mode is not enabled or the output number is wrong.	<ul style="list-style-type: none"> The output number that was specified in Adjustment Mode is not enabled. The setting of the Adjustment Output Number (device variable <i>*_AdjCh</i>) is incorrect, so adjustment is not possible. 			U	S		W490

Event code	Event name	Meaning	Assumed cause	Level					Reference
				Maj	Prt	Min	Obs	Info	
348C0000 hex	I/O Number Specification Error in Adjustment Mode	The I/O numbers specified in Adjustment Mode are not enabled or the I/O numbers are wrong.	<ul style="list-style-type: none"> The I/O numbers that were specified in Adjustment Mode are not enabled. The setting of the Adjustment I/O Number (device variable *_AdjCh) is incorrect, so adjustment is not possible. 			U	S		W490

CJ-series Process I/O Units

The section provides tables of the errors (events) that can occur in the following Units.

CJ1W-PDC15

CJ1W-AD04U

CJ1W-PH41U

The manual names are given below for the catalog numbers given in the *Reference* column of the event table.

Cat. No.	Manual name
W498	CJ-series Analog I/O Units Operation Manual for NJ-series CPU Unit

Event code	Event name	Meaning	Assumed cause	Level					Reference
				Maj	Prt	Min	Obs	Info	
04600000 hex	A/D Conversion Error	An error occurred in A/D conversion.	<ul style="list-style-type: none"> There is a source of noise nearby. A/D converter failed. 			S	U		W498
04610000 hex	Cold Junction Sensor Error	An error occurred in the cold junction sensor.	<ul style="list-style-type: none"> Faulty connection to the cold junction sensor for the CJ1W-PH41U. The cold junction sensor failed. 			S	U		W498
04620000 hex	Non-volatile Memory Error	An error occurred in non-volatile memory.	<ul style="list-style-type: none"> There is a source of noise nearby. Non-volatile memory failed. 			S			W498
348D0000 hex	Data Range Error	A set value is out of range.	<ul style="list-style-type: none"> A set value is out of range. 			S			W498
647A0000 hex	Input Error	An input error occurred.	<ul style="list-style-type: none"> The analog input signal is out of range. Input wiring is broken. Input wiring disconnection or loose terminal 			S	U		W498
647D0000 hex	Zero/Span Adjustment Period End	The zero/span adjustment period expired.	<ul style="list-style-type: none"> The zero/span adjustment period expired. 			U	S		W498
647E0000 hex	Zero/Span Adjustment Period Notice	The zero/span adjustment period is close to expiring.	<ul style="list-style-type: none"> The notification period for the expiration of zero/span adjustment occurred. 			U	S		W498

CJ-series Temperature Control Units

The section provides tables of the errors (events) that can occur in the following Units.

CJ1W-TC003

CJ1W-TC004

CJ1W-TC103

CJ1W-TC104

The manual names are given below for the catalog numbers given in the *Reference* column of the event table.

Cat. No.	Manual name
W491	CJ-series Temperature Control Units Operation Manual for NJ-series CPU Unit

Event code	Event name	Meaning	Assumed cause	Level					Reference
				Maj	Prt	Min	Obs	Info	
04680000 hex	Cold Junction Sensor Error	An error occurred in the cold junction sensor.	<ul style="list-style-type: none"> Faulty connection to the cold junction sensor. The cold junction sensor failed. 			U	S		W491
34940000 hex	Setting Error	There is an illegal setting.	<ul style="list-style-type: none"> The set value is incorrect. 			U	S		W491
64840000 hex	Sensor Error	An error occurred in the sensor input.	<ul style="list-style-type: none"> Error in input from the Sensor. 			U	S		W491
64850000 hex	CT Overflow	An overflow occurred in the CT input.	<ul style="list-style-type: none"> The heater current exceeded 55.0 A. 			U	S		W491
64860000 hex	Heater Burn-out Alarm	A heater burnout occurred.	<ul style="list-style-type: none"> The power supply to the heater is not ON. The heater is burned out or deteriorated. 			U	S		W491

CJ-series ID Sensor Units

The section provides tables of the errors (events) that can occur in the following Units.

CJ1W-V680C11

CJ1W-V680C12

The manual names are given below for the catalog numbers given in the *Reference* column of the event table.

Cat. No.	Manual name
Z317	CJ-series ID Sensor Units Operation Manual for NJ-series CPU Unit

Event code	Event name	Meaning	Assumed cause	Level					Reference
				Maj	Prt	Min	Obs	Info	
046C0000 hex	Unit Status, Antenna Power Supply Error	An error occurred in the power supply to the Antenna.	<ul style="list-style-type: none"> An error occurred in the power supply (24 V) to the Antenna. 			S			Z317
046D0000 hex	Unit Status, Memory Error	An error occurred when reading non-volatile memory.	<ul style="list-style-type: none"> There is a source of noise nearby. Non-volatile memory failure 			S			Z317
046E0000 hex	Results Information, Antenna Error	An error occurred in the Antenna.	<ul style="list-style-type: none"> The Antenna is not connected. Antenna failure The ID Sensor Unit failed. 			S			Z317

Event code	Event name	Meaning	Assumed cause	Level					Reference
				Maj	Prt	Min	Obs	Info	
046F0000 hex	Unit Status, Unit Busy	An error occurred in an ID Sensor Unit.	<ul style="list-style-type: none"> There is a source of noise nearby. The ID Sensor Unit failed. 			S			Z317
24400000 hex	Unit Status, Antenna Error	An error occurred in the Antenna.	<ul style="list-style-type: none"> The setting of the Connected Antenna Setting (device variable *_Ch#_AntConn) does not agree with the Antenna that is connected. The V680-H01 or V680-H01-V2 was connected to the CJ1W-V680C12. 			S			Z317
34980000 hex	Results Information, Data Storage Area Specification Error	The data storage area specification is not correct.	<ul style="list-style-type: none"> The user program specifies addresses in the DM, CIO, AR, EM, or other areas that exceed the ranges defined for the data storage area specifications. 			S			Z317
54A00000 hex	Results Information, ID Tag Address Error	The address of the ID Tag is wrong.	<ul style="list-style-type: none"> The address of an ID Tag specified in a command is incorrect. 			S			Z317
54A10000 hex	Results Information, Write Protection Error	An attempt was made to write to a write-protected area of the ID Tag.	<ul style="list-style-type: none"> The specified address or number of bytes is incorrect. Write-protection is enabled for the area you attempted to write to in the ID Tag. 			S			Z317
54A20000 hex	Results Information, Command Error	The command to the ID Sensor Unit is not correct.	<ul style="list-style-type: none"> The contents of the following external device variables is not data that can be specified (where # is the channel number). <ul style="list-style-type: none"> *_Ch#_CmdSet *_Ch#_ProcAdr *_Ch#_ProcByte *_Ch#_CmdOption "#" in the variable name is the Antenna (Head) number. 			S			Z317
648C0000 hex	Unit Status, Command Error End	A processing error occurred.	<ul style="list-style-type: none"> A processing error occurred. 			S			Z317
648D0000 hex	Results Information, Verification Error	The correct data could not be written to the ID Tag.	<ul style="list-style-type: none"> The travel speed of the ID Tag is outside the specified range. The distance between the Antenna and ID Tag is outside the specified range. Noise 			S			Z317
648E0000 hex	Results Information, ID Tag Communications Error	An error occurred in communications with an ID Tag, preventing a normal end.	<ul style="list-style-type: none"> The travel speed of the ID Tag is outside the specified range. The distance between the Antenna and ID Tag is outside the specified range. Noise 			S			Z317
648F0000 hex	Results Information, ID Tag Missing Error	There is no ID Tag in the communications area.	<ul style="list-style-type: none"> The communications specification is set to trigger, and the ID Tag is not in the communications area when the trigger occurs. The communications specification is set to single auto or repeat auto, and the wait time reached the Auto Wait Time. An Amplifier is connected, but an Antenna is not connected. 			S			Z317

Event code	Event name	Meaning	Assumed cause	Level					Reference
				Maj	Prt	Min	Obs	Info	
64900000 hex	Results Information, ID System Error 1	ID system error 1 occurred.	<ul style="list-style-type: none"> System error 1 occurred. 			S			Z317
64910000 hex	Results Information, ID System Error 2	ID system error 2 occurred.	<ul style="list-style-type: none"> System error 2 occurred. 			S			Z317
64920000 hex	Results Information, ID System Error 3	ID system error 3 occurred.	<ul style="list-style-type: none"> System error 3 occurred. 			S			Z317
64930000 hex	Results Information, ID Tag Status	<p>One of the following occurred.</p> <ul style="list-style-type: none"> The number of writes was exceeded for a Number of Writes Control command. An overflow or underflow occurred for a Calculation Write command. The data did not verify for a Data Check command. An error occurred in the data for a Read with Error Correction command. An error occurred when writing for a Copy command. 	<ul style="list-style-type: none"> The number of writes was exceeded for a Number of Writes Control command. An overflow or underflow occurred for a Calculation Write command. The data did not verify for a Data Check command. An error occurred in the data for a Read with Error Correction command. An error occurred when writing for a Copy command. 			S			Z317
64940000 hex	Results Information, Error Correction	A Write with Error Correction command performed a 1-bit error correction.	<ul style="list-style-type: none"> There is ambient noise where the ID Tag is used. ID Tag error. 			S			Z317

CJ-series High-speed Counter Units

The section provides tables of the errors (events) that can occur in the following Units.

CJ1W-CT021

The manual names are given below for the catalog numbers given in the *Reference* column of the event table.

Cat. No.	Manual name
W492	CJ-series High-speed Counter Units Operation Manual for NJ-series CPU Unit

Event code	Event name	Meaning	Assumed cause	Level					Reference
				Maj	Prt	Min	Obs	Info	
68010000 hex	Unit Error	An error occurred in the High-speed Counter Unit.	<ul style="list-style-type: none"> There is an error in the Special Unit Setup. An overflow or underflow error occurred. An illegal preset value was used. A CPU Unit monitor error or bus error occurred. 			S			W492

CJ-series Serial Communications Units

The section provides tables of the errors (events) that can occur in the following Units.

CJ1W-SCU22

CJ1W-SCU32

CJ1W-SCU42

The manual names are given below for the catalog numbers given in the *Reference* column of the event table.

Cat. No.	Manual name
W494	CJ-series Serial Communications Units Operation Manual for NJ-series CPU Unit

Event code	Event name	Meaning	Assumed cause	Level					Reference
				Maj	Prt	Min	Obs	Info	
04740000 hex	Error Log Data Error	An error occurred in the error log data.	<ul style="list-style-type: none"> There is a source of noise nearby. Non-volatile memory failure 			S			W494
14800000 hex	Protocol Data Error	A protocol data checksum error has occurred.	<ul style="list-style-type: none"> The communications connector with the CX-Protocol was disconnected or the power supply to the Controller was interrupted during transfer of the protocol data from the CX-Protocol. The Serial Communications Unit failed. 			S			W494
34A40000 hex	System Setup Error	There is an error in the system settings for the Serial Communications Unit.	<ul style="list-style-type: none"> There is an error in the system settings for the Serial Communications Unit. 			S			W494
04750000 hex	DTR Check Error	An error was found during the DTR check.	<ul style="list-style-type: none"> Loopback test jig failure. Noise The communications circuits in the Serial Communications Unit are faulty. 				S		W494
04760000 hex	CTS Check Error	An error was found during the CTS check.	<ul style="list-style-type: none"> Loopback test jig failure. Noise The communications circuits in the Serial Communications Unit are faulty. 				S		W494
54A80000 hex	Command Error	A command error occurred.	<ul style="list-style-type: none"> The constant in the expected receive message that is set in the protocol macro is different from the constant in the message that was received. 				S		W494
54A90000 hex	Sequence Abort Completed	The sequence was ended by an Abort setting for the next processing or error processing.	<ul style="list-style-type: none"> The protocol macro data is not set correctly. The baud rate, frame format, or other system setting does not agree with the remote node. 				S		W494

Event code	Event name	Meaning	Assumed cause	Level					Reference
				Maj	Prt	Min	Obs	Info	
54AA0000 hex	Protocol Macro Error	An error occurred in the protocol macro.	<ul style="list-style-type: none"> Sequence No. Error: An unregistered number was specified for <i>SeqNo</i> (communications sequence number) of the ExecPMCR instruction (no indicators light). Data read/write area exceeded error: The specified area range was exceeded when data was written to or read from the CPU Unit. (The ERC indicator and ERR/ALM indicator will flash.) Protocol data syntax error: There was a code that cannot be executed during protocol execution. (The ERC indicator and ERR/ALM indicator will flash.) The total of the areas specified for link words O1, O2, I1, and I2 exceeded 500 words. The same link word is used by both ports 1 and 2. Writing was specified with a constant. Interrupt notification was specified for a Serial Communications Unit. Thirty one or more items were set for the write attribute data for one message. A length of 0 bytes was specified for a message that was sent or received. The length of a message to be sent or received exceeds the maximum send/receive bytes. A message is not registered for matrix reception. The transmission control is set to both RTS/CTS flow control and Xon/Xoff flow control. 				S		W494
64A00000 hex	Tfs (Send Finished Monitoring Time) Exceeded	The time required to complete a send operation exceeded the Send Finished Monitoring Time.	<ul style="list-style-type: none"> Noise The monitor time is shorter than the actual completion time. 				S		W494
64A10000 hex	Tfr (Receive Finished Monitoring Time) Exceeded	The time required to complete a reception operation exceeded the Receive Finished Monitoring Time.	<ul style="list-style-type: none"> Noise The monitoring time is shorter than the actual completion time. 				S		W494
64A20000 hex	Tr (Receive Wait Monitoring Time) Exceeded	The receive waiting time exceeded the Receive Wait Monitoring Time.	<ul style="list-style-type: none"> Noise The monitoring time is shorter than the actual completion time. 				S		W494

Event code	Event name	Meaning	Assumed cause	Level					Reference
				Maj	Prt	Min	Obs	Info	
64A30000 hex	FCS Check Error	<p>One of the following errors occurred in the converted protocol at the serial gateway.</p> <ul style="list-style-type: none"> When converting to CompoWay/F command: BCC error When converting to Modbus-RTU command: CRC error When converting to Modbus-ASCII command: CRC error When converting to Host Link FINS command: FCS error <p>Protocol Macros</p> <ul style="list-style-type: none"> The check code attached to the received message does not match the check code that was calculated from the received message. 	<ul style="list-style-type: none"> Noise There was a mistake in the CRC code that was attached to the command frame. 				S		W494
64A40000 hex	Timeout Error	A timeout error occurred.	<ul style="list-style-type: none"> The steps in the communications sequence of a protocol macro are not progressing. There is no remote device to receive the command. The command frame is incorrect. The remote device is not using the same serial communications settings. Wiring is not correct or terminating resistance is not set correctly. The remote device could not interpret the protocol command. The response from the remote device was sent too soon. The response timeout monitoring time of the serial gateway is too short. The loopback test jig failed. The communications circuits in the Serial Communications Unit are faulty. A serial gateway interrupted processing between protocol macro steps. Noise occurred. The Serial Communications Mode setting is incorrect. 				S		W494

Event code	Event name	Meaning	Assumed cause	Level					Reference
				Maj	Prt	Min	Obs	Info	
64A50000 hex	Comparison Error	A comparison error occurred.	<ul style="list-style-type: none"> • Loopback test jig failure. • Noise • The communications circuits in the Serial Communications Unit are faulty. 				S		W494
64A60000 hex	Reception Overflow	More than the specified amount of receive data was received in No-protocol Mode.	<ul style="list-style-type: none"> • One or more bytes of data was received after the completion the reception. 				S		W494
64A70000 hex	Command Format Error	An illegal function code or address was specified in a received Modbus-RTU command.	<ul style="list-style-type: none"> • An illegal function code, address, or data was specified in a received Modbus-RTU command. 				S		W494
84680000 hex	Transmission Error	A transmission error occurred.	<ul style="list-style-type: none"> • One of the following errors occurred. <ul style="list-style-type: none"> • Tfs (Send Finished Monitoring Time) Exceeded • Tfr (Receive Finished Monitoring Time) Exceeded • Tr (Receive Wait Monitoring Time) Exceeded • FCS Check Error • Command Error • Timeout Error • Overrun Error • Framing Error • Parity Error 				S		W494
84690000 hex	Overrun Error	An overrun occurred.	<ul style="list-style-type: none"> • In Serial Gateway Mode or Protocol Macro Mode: <ul style="list-style-type: none"> • The reception circuits in the Serial Communications Unit are faulty. • A transmission error occurred due to noise or other factors. • No-protocol Mode: <ul style="list-style-type: none"> • The reception buffer received more than 259 bytes of data before the SerialRcv/SerialRcvNoClear instruction was executed. • During Loopback Test <ul style="list-style-type: none"> • Loopback test jig failure. • Noise • The communications circuits in the Serial Communications Unit are faulty. 				S		W494
846A0000 hex	Framing Error	A frame error occurred.	<ul style="list-style-type: none"> • In Serial Gateway Mode or Protocol Macro Mode: <ul style="list-style-type: none"> • The reception circuits in the Serial Communications Unit are faulty. • A transmission error occurred due to noise or other factors. • During Loopback Test <ul style="list-style-type: none"> • Loopback test jig failure. • Noise • The communications circuits in the Serial Communications Unit are faulty. 				S		W494

Event code	Event name	Meaning	Assumed cause	Level					Reference
				Maj	Prt	Min	Obs	Info	
846B0000 hex	Parity Error	A parity error occurred.	<ul style="list-style-type: none"> • In Serial Gateway Mode or Protocol Macro Mode: <ul style="list-style-type: none"> • The reception circuits in the Serial Communications Unit are faulty. • A transmission error occurred due to noise or other factors. • During Loopback Test <ul style="list-style-type: none"> • Loopback test jig failure. • Noise • The communications circuits in the Serial Communications Unit are faulty. 				S		W494
846C0000 hex	Overrun Error, Framing Error, or Parity Error (Transmission Error)	An overrun error, framing error, or parity error occurred.	<ul style="list-style-type: none"> • The communications conditions and baud rate settings do not match the host. • Noise or other external interference. • The baud rate is outside the allowable range or there are bit errors due to different stop bit settings or other parameters. • The communications cable wiring is faulty. • Terminating resistance is not set correctly for the RS-422A/485 ports. • Wiring is faulty or terminating resistance is not set correctly on an NT-AL001 or other Adapter. 				S		W494
846D0000 hex	Transmission Error (CRC Error)	A CRC error occurred.	<ul style="list-style-type: none"> • Noise • CRC calculation method does not match the device. 				S		W494

CJ-series DeviceNet Units

The section provides tables of the errors (events) that can occur in the following Units.

CJ1W-DRM21

The manual names are given below for the catalog numbers given in the *Reference* column of the event table.

Cat. No.	Manual name
W497	CJ-series DeviceNet Units Operation Manual for NJ-series CPU Unit

Event code	Event name	Meaning	Assumed cause	Level					Reference
				Maj	Prt	Min	Obs	Info	
04880000 hex	Unit Memory Error	An error occurred when writing to internal memory where the error history is saved.	<ul style="list-style-type: none"> There is a source of noise nearby. Non-volatile memory failure 			S	U		W497
04890000 hex	Network Power Error	Network power is not being supplied.	<ul style="list-style-type: none"> Communications power is not being supplied normally from the network. 			S			W497
148D0000 hex	Invalid Scan List Data	There is an error in the contents of the slave scan list or master scan list stored in non-volatile memory.	<ul style="list-style-type: none"> The power was interrupted during writing the scan list to the non-volatile memory. 			S			W497
148E0000 hex	Invalid Setup Data	There is illegal data in the settings for the slave function.	<ul style="list-style-type: none"> The power was interrupted while the system was writing the parameters. Non-volatile memory life 			S			W497
24480000 hex	Node Address Duplicated Error	An error was discovered during the node address duplication check when starting the DeviceNet Unit.	<ul style="list-style-type: none"> The node address of the DeviceNet Unit is also set for another node. 			S			W497
34BC0000 hex	Routing Table Error	There is illegal data in the routing tables set in the CPU Unit.	<ul style="list-style-type: none"> The local DeviceNet Unit is not in the routing tables. The routing table format is incorrect. Reading the routing tables timed out. 			S	U		W497

Event code	Event name	Meaning	Assumed cause	Level					Reference
				Maj	Prt	Min	Obs	Info	
34BD0000 hex	Verification Error	The slave information registered in the scan list does not agree with the actual slave information.	<ul style="list-style-type: none"> A slave that is in the scan list does not exist. The node address of the local Unit, which is the master, is registered in the scan list. If the system is set to check the vendor in the detailed verification settings, the vendor of the slave does not match the registration in the scan list. If the connection path is set in the detailed verification settings, then setting the connection path that is set in the scan list failed. The size of the slave I/O data does not match the registration in the scan list. If the device type is set in the detailed verification settings, then setting the device type that is set in the scan list failed. If the product code is set in the detailed verification settings, then setting the product code that is set in the scan list failed. The device does not support the I/O service specified in the scan list. 			S			W497
34BE0000 hex	Structure Error	The scan list is disabled and an error occurred that prevented making I/O allocations.	<ul style="list-style-type: none"> The I/O words allocated to slave overlap. The I/O words allocated to the slave exceed the valid range. The I/O size of the slave exceeds 200 bytes for outputs or 200 bytes for inputs. 			S			W497
34BF0000 hex	Master I/O Refresh Error	The I/O memory in the destination CPU Unit for I/O refreshing could not be found when refreshing the master function data in the CPU Unit.	<ul style="list-style-type: none"> I/O words are allocated in an EM bank that does not exist. 			S			W497
34C00000 hex	Master User-set Allocations User Setting Failed	An error occurred in the following operation for user allocation of the master.	<ul style="list-style-type: none"> The master function is not enabled. There is a mistake in the user allocations in the master. CPU Unit is not in PROGRAM mode. More than one software switch changed to TRUE at the same time. Or, another software switch changed to TRUE before processing was completed for a previous software switch. 			S			W497
34C10000 hex	Communications Cycle Time Setting Failed	An error occurred in one of the following operations when setting the communications cycle time.	<ul style="list-style-type: none"> There is an error in the set information. CPU Unit is not in PROGRAM mode. 			S			W497

Event code	Event name	Meaning	Assumed cause	Level					Reference
				Maj	Prt	Min	Obs	Info	
34C20000 hex	Slave I/O Refresh Error	The I/O memory in the destination CPU Unit for I/O refreshing could not be found when refreshing the slave function data in the CPU Unit.	<ul style="list-style-type: none"> I/O words are allocated in an EM bank that does not exist. 			S			W497
34C30000 hex	Slave User Allocation Area Setting Failed	An error occurred in the following operation for user allocation of the slave.	<ul style="list-style-type: none"> The slave function is not disabled. There is a mistake in the user allocations to a slave. CPU Unit is not in PROGRAM mode. More than one software switch changed to TRUE at the same time. Or, another software switch changed to TRUE before processing was completed for a previous software switch. 			S			W497
64AC0000 hex	Send Timeout Error	A send timeout occurred.	<ul style="list-style-type: none"> There is no slave or other device on the network. The same baud rate is not set for all nodes. Communications cable lengths (trunk line and branch lines) are unsuitable. A communications cable is disconnected or loose. The terminating resistance is somewhere other than the ends of the trunk line. Noise There is an error in the CAN controller. 			S			W497
74600000 hex	Master Function Enable/Disable Failed	An operating error occurred when enabling or disabling the master function.	<ul style="list-style-type: none"> An attempt was made to enable the master function when it was already enabled. An attempt was made to disable the master function when it was already disabled. CPU Unit is not in PROGRAM mode. More than one software switch changed to TRUE at the same time. Or, another software switch changed to TRUE before processing was completed for a previous software switch. 			S			W497
74610000 hex	Master Fixed Allocation Area Setting Failed	An error occurred in one of the following operations for fixed allocation of the master.	<ul style="list-style-type: none"> The master function is not enabled. The scan list is not disabled. CPU Unit is not in PROGRAM mode. More than one software switch changed to TRUE at the same time. Or, another software switch changed to TRUE before processing was completed for a previous software switch. 			S			W497

Event code	Event name	Meaning	Assumed cause	Level					Reference
				Maj	Prt	Min	Obs	Info	
74620000 hex	Scan List Register/Clear Failed	An operating error occurred when registering or clearing the scan list by performing one of the following operations.	<ul style="list-style-type: none"> • CPU Unit is not in PROGRAM mode. • Request processing is not possible in this status or the request was made when the operation was already in progress. The following are the main causes of Unit status errors. <ul style="list-style-type: none"> • A software switch operation for the master function was executed when the master function was disabled. • A switch that can be used only when the scan list is disabled was used when the scan list was enabled. • A switch that can be used only when the scan list is enabled was used when the scan list was disabled. • A software switch operation for the slave function was executed when the slave function was disabled. • A configuration error has occurred. • There is an error in the parameters specified in the user settings, and the requested setting could not be made. • More than one software switch changed to TRUE at the same time. Or, another software switch changed to TRUE before processing was completed for a previous software switch. 			S			W497
74630000 hex	Slave Function Enable/Disable Failed	An error occurred in one of the following operations in the slave function.	<ul style="list-style-type: none"> • An attempt was made to enable the slave function when it was already enabled. • An attempt was made to disable the slave function when it was already disabled. • CPU Unit is not in PROGRAM mode. • More than one software switch changed to TRUE at the same time. Or, another software switch changed to TRUE before processing was completed for a previous software switch. 			S			W497
74640000 hex	Slave Fixed Allocation Area Setting Failed	An error occurred in one of the following operations for fixed allocation of the slave.	<ul style="list-style-type: none"> • The slave function is not disabled. • CPU Unit is not in PROGRAM mode. • More than one software switch changed to TRUE at the same time. Or, another software switch changed to TRUE before processing was completed for a previous software switch. 			S			W497

Event code	Event name	Meaning	Assumed cause	Level					Reference
				Maj	Prt	Min	Obs	Info	
84740000 hex	Bus Off Detected	A Bus Off error occurred (i.e., communications stopped because there were too many communications errors).	<ul style="list-style-type: none"> The master and slave have different baud rates. Communications cable lengths (trunk line and branch lines) are unsuitable. A communications cable is disconnected or loose. The terminating resistance is somewhere other than the ends of the trunk line. Noise 			S			W497
84750000 hex	Remote I/O Communications Error	A timeout occurred in remote I/O communications.	<ul style="list-style-type: none"> The master and slaves have different baud rates. Communications cable lengths (trunk line and branch lines) are unsuitable. A communications cable is disconnected or loose. The terminating resistance is somewhere other than the ends of the trunk line. Noise 			S	U		W497
84760000 hex	Remote I/O Communications Error (during Slave Operation)	An error occurred in remote I/O communications.	<ul style="list-style-type: none"> The master is not in operation. The master and slaves have different baud rates. Communications cable lengths (trunk line and branch lines) are unsuitable. A communications cable is disconnected or loose. The terminating resistance is somewhere other than the ends of the trunk line. Noise 			S			W497
84770000 hex	Slave COS Send Failed	An attempt was made to send COS data to the master using the Slave COS Send Switch (software switch 2, device variable * <i>_Sw2SlavCOS-SendCmd</i>), but the send failed.	<ul style="list-style-type: none"> A COS connection to the master is not open. A Bus Off state occurred. A network power error occurred. A send timeout occurred. 			S			W497
048A0000 hex	File Read/Write Error	An error occurred when user setup data was read from an SD Memory Card in the CPU Unit or when data was written as a file to an SD Memory Card.	<ul style="list-style-type: none"> The available capacity on the SD Memory Card was insufficient to write a file. Write-protection is set on the SD Memory Card when you write to a file. Noise The SD Memory Card is damaged. The CPU Unit has failed. 			U	S		W497
148C0000 hex	Invalid Message Timer List Error	The data in the message monitoring timer list is not correct.	<ul style="list-style-type: none"> The power supply was interrupted while writing the message-monitoring timer list to the non-volatile memory. 			U	S		W497

CJ-series EtherNet/IP Unit

The section provides tables of the errors (events) that can occur in the following Units.

CJ1W-EIP21

The manual names are given below for the catalog numbers given in the *Reference* column of the event table.

Cat. No.	Manual name
W495	CJ-series EtherNet/IP Units Operation Manual for NJ-series CPU Unit

Event code	Event name	Meaning	Assumed cause	Level					Reference
				Maj	Prt	Min	Obs	Info	
047A0000 hex	Unit Memory Error (Device Error)	An error occurred when writing to the error history or device parameters in non-volatile memory in the EtherNet/IP Unit.	<ul style="list-style-type: none"> There is a source of noise nearby. Non-volatile memory failure 			S			W495
047B0000 hex	Non-volatile Memory Error	An error occurred in non-volatile memory.	<ul style="list-style-type: none"> There is a source of noise nearby. Non-volatile memory failure 			S			W495
047C0000 hex	Communications Controller Error	An error occurred in the communications controller.	<ul style="list-style-type: none"> Noise Communications Controller hardware error 			S			W495
14840000 hex	Invalid Communications Parameter	An error was found in the validation check of the parameters for tag data links that are saved in non-volatile memory.	<ul style="list-style-type: none"> The power was interrupted during a download. A communications error occurred during a download. Non-volatile memory failure 			S			W495
14850000 hex	Tag Database Error	A tag database error occurred in the CPU Unit when using variables for tag data links, status layout, etc.	<ul style="list-style-type: none"> The power was interrupted during a download. A communications error occurred during a download. 			S			W495
34A80000 hex	Verification Error	The information registered for a target node in the tag data link parameters is different from the actual node information.	<ul style="list-style-type: none"> The specified target does not exist. Variable names do not match. The connection size is incorrect. Insufficient connection resources 			S			W495
34A90000 hex	Tag Data Link Error	There were two or more errors in a connection as an originator. The following are excluded. <ul style="list-style-type: none"> Connections as a target Connection time-outs due to a Link OFF Error with the Ethernet switch 	<ul style="list-style-type: none"> The power supply to the target node is OFF. Communications with the target node stop. The Ethernet cable for EtherNet/IP is disconnected. The Ethernet cable for EtherNet/IP is disconnected. Noise 			S			W495

3 Error Tables

Event code	Event name	Meaning	Assumed cause	Level					Reference
				Maj	Prt	Min	Obs	Info	
34AA0000 hex	Tag Refresh Error	An unsupported data area or address range is specified for the tag data links.	<ul style="list-style-type: none"> An unsupported data area or address range was specified for the tag data links. 			S			W495
34AB0000 hex	Basic Ethernet Setting Error	There is an illegal TCP/IP setting.	<ul style="list-style-type: none"> The power was interrupted during a download. A communications error occurred during a download. 			S			W495
34AC0000 hex	IP Address Table Error	The IP address table information is incorrect.	<ul style="list-style-type: none"> The power was interrupted during a download. A communications error occurred during a download. 			S			W495
34AD0000 hex	IP Router Table Error	The IP router table information is incorrect.	<ul style="list-style-type: none"> The power was interrupted during a download. A communications error occurred during a download. 			S			W495
34AE0000 hex	Routing Table Error	The routing table information is incorrect.	<ul style="list-style-type: none"> The power was interrupted during a download. A communications error occurred during a download. 			S			W495
34AF0000 hex	Ethernet Advanced Setting Error	There is an illegal FINS setting.	<ul style="list-style-type: none"> The power was interrupted during a download. A communications error occurred during a download. 			S			W495
34B00000 hex	Address Mismatch	The host ID of the local IP address is inconsistent with the FINS node address. Or, the last segment of the local IP address is inconsistent with the setting on the node address switches.	<ul style="list-style-type: none"> The IP address conversion method is set to automatic generation, but the host ID of the local IP address is inconsistent with the FINS node address or the last segment of the local IP address is inconsistent with the setting on the node address switch. 			S			W495
381C0000 hex	Status Area Layout Setting Error	An error occurred in the layout setting of the EtherNet/IP Unit.	<ul style="list-style-type: none"> There is an error in the layout settings of the EtherNet/IP Unit. 			S			W495
54AE0000 hex	Multiple Switches ON Error	More than one software switch changed to TRUE at the same time.	<ul style="list-style-type: none"> More than one software switch changed to TRUE at the same time. Or, another software switch changed to TRUE before processing was completed for a previous software switch. 			S	U		W495
84E00000 hex	IP Address Duplication Error	The same IP address is used more than once.	<ul style="list-style-type: none"> The IP address of the EtherNet/IP port is also used as the IP address of another node. 			S			W495

Event code	Event name	Meaning	Assumed cause	Level					Reference
				Maj	Prt	Min	Obs	Info	
84E10000 hex	BOOTP Server Error	Connection with the BOOTP server failed.	<ul style="list-style-type: none"> Server setting error (The acquired IP address is illegal.) Server is down. An error occurred in the communications path. 			S			W495
54AF0000 hex	Access Detected Outside Range of Variable	Accessing a value that is out of range was detected for a tag variable that is used in a tag data link.	<ul style="list-style-type: none"> An out-of-range value was written by an EtherNet/IP tag data link for a variable with a specified range. A value that does not specify an enumerator was written by an EtherNet/IP tag data link for an enumeration variable. 				S		W495
84E20000 hex	Link OFF Error	The Ethernet link status turned OFF.	<ul style="list-style-type: none"> The Ethernet cable is disconnected. An Ethernet cable is disconnected or loose. The switching hub power supply is turned OFF. Baud rate mismatch. Noise 			U	S		W495

CJ-series CompoNet Master Unit

The section provides a table of the errors (events) that can occur in the following Unit.

CJ1W-CRM21

The manual names are given below for the catalog numbers given in the *Reference* column of the event table.

Cat. No.	Manual name
W493	CJ-series CompoNet Master Units Operation Manual for NJ-series CPU Unit

Event code	Event name	Meaning	Assumed cause	Level					Reference
				Maj	Prt	Min	Obs	Info	
349C0000 hex	Registration Table Verification Error	An inconsistency was found when verifying the slave registration table.	<ul style="list-style-type: none"> There is at least one entry in the slave registration table where the node address and Slave Unit model are inconsistent. 			S			W493
349D0000 hex	Slave Unit Duplicated Address Error	The same address is used by more than one Slave Unit or the same word has been allocated to more than one Slave Unit.	<ul style="list-style-type: none"> The same node address is set for more than one Slave Unit. There are no duplicated node addresses set for the Slave Units, but allocated words overlap. A Slave Unit was disconnected from the network, and then another Slave Unit with the same node address but a different I/O capacity joined the network. 			S			W493
349E0000 hex	Repeater Unit Node Duplicated Address Error	The node address of the Repeater Unit is also set for another node.	<ul style="list-style-type: none"> The node address of the Repeater Unit is also used for another node. 			S			W493

Event code	Event name	Meaning	Assumed cause	Level					Reference
				Maj	Prt	Min	Obs	Info	
8460000 hex	Communications Error	A Slave Unit was disconnected from the network.	<ul style="list-style-type: none"> Cable lengths (trunk line and branch lines) are unsuitable. A cable is disconnected or loose. A terminating resistance is not connected. Or, the terminating resistance is somewhere other than the end of the trunk line. Noise The Slave Unit does not respond to communications from the Master Unit because the Slave Unit is faulty, the line is disconnected, or the communications power supply is interrupted. 			S	U		W493
8461000 hex	Repeater Unit Communications Error	An error occurred in Repeater Unit communications.	<ul style="list-style-type: none"> Cable lengths (trunk line and branch lines) are unsuitable. A cable is disconnected or loose. A terminating resistance is not connected. Or, the terminating resistance is somewhere other than the end of the trunk line. Noise The Repeater Unit does not respond to communications from the Master Unit because the Repeater Unit is faulty, the line is disconnected, or the communications power is interrupted. 			S	U		W493
6498000 hex	Representative Warning	A warning has occurred in at least one Slave Unit.	<ul style="list-style-type: none"> A warning has occurred in at least one Slave Unit. 				S		W493
6499000 hex	Representative Alarm	An alarm has occurred in at least one Slave Unit.	<ul style="list-style-type: none"> An alarm has occurred in at least one Slave Unit. 				S		W493

3-2 An Error Log Table for CJ-series Special Units

Error logs for CJ-series Special Units are also displayed with event logs. If the upper four digits of the event code are 0000, the lower four digits of the event code give the error code for error logs from CJ-series Special Units.

For descriptions of error codes for the relevant error logs, refer to the manual of models that are displayed in *Source Details* on the Sysmac Studio or in *Source* on the HMI. The following table gives the corresponding manuals for models.

Model	Manual name	Cat. No.
CJ1W-AD0□□-□□ CJ1W-DA0□□□ CJ1W-MAD42	CJ-series Analog I/O Units Operation Manual for NJ-series CPU Unit	W490
CJ1W-TC003 CJ1W-TC004 CJ1W-TC103 CJ1W-TC104	CJ-series Temperature Control Units Operation Manual for NJ-series CPU Unit	W491
CJ1W-CT021	CJ-series High-speed Counter Units Operation Manual for NJ-series CPU Unit	W492
CJ1W-PDC15 CJ1W-PH41U CJ1W-AD04U	CJ-series Analog I/O Units Operation Manual for NJ-series CPU Unit	W498
CJ1W-CRM21	CJ-series CompoNet Master Units Operation Manual for NJ-series CPU Unit	W493
CJ1W-SCU22 CJ1W-SCU32 CJ1W-SCU42	CJ-series Serial Communications Units Operation Manual for NJ-series CPU Unit	W494
CJ1W-EIP21	CJ-series EtherNet/IP Units Operation Manual for NJ-series CPU Unit	W495
CJ1W-DRM21	CJ-series DeviceNet Units Operation Manual for NJ-series CPU Unit	W497
CJ1W-ECT21	CJ-series EtherCAT Slave Units Operation Manual for NJ-series CPU Unit	W542
CJ1W-V680C11 CJ1W-V680C12	CJ-series ID Sensor Units Operation Manual for NJ-series CPU Unit	Z317

For example, if the following information are displayed on the Sysmac Studio, refer to descriptions of the error code 000E given in the *CJ-series EtherNet/IP Units Operation Manual for NJ-series CPU Unit* (Cat. No. W495) for the CJ1W-EIP21.

Source	Source details	Event name	Event code
I/O bus	Rack 0, Slot 3 CJ1W-EIP21	I/O Bus Error	0x0000000E

The following table gives error logs for CJ-series Special Units. The level of all errors is *Observation*. The Controller errors do not occur because they are not events.

Event code	Error name
00000001 hex	CPU Unit watchdog timer error
00000002 hex	CPU Unit service monitor error, or Cyclic refresh Time-out
00000003 hex	CPU Unit shared RAM error
00000004 hex	CPU Bus Unit ID number error
00000005 hex	Unit number error
00000006 hex	CPU Unit error

Event code	Error name
00000007 hex	PF Return
00000008 hex	System setting error
00000009 hex	System setting read error
0000000A hex	Routing table lost
0000000B hex	Routing Table Error
0000000C hex	Routing table read error
0000000D hex	PLC model error
0000000E hex	I/O Bus Error
0000000F hex	PLC Initialization error
00000010 hex	Insufficient system setup area
00000011 hex	Event timeout
00000012 hex	CPU Unit memory error
00000013 hex	CPU Unit protected
00000014 hex	Inner bus error
00000015 hex	CPU fatal error
00000016 hex	CPU unit non-fatal error
00000017 hex	Tag database error
00000101 hex	Transmission failed (local node not in network)
00000102 hex	Transmission failed (Time out with token)
00000103 hex	Transmission failed (retry count exceeded)
00000104 hex	Transmission failed (max. number of frames exceeded)
00000105 hex	Transmission failed (node address setting error)
00000106 hex	Transmission failed (node address duplication error)
00000107 hex	Transmission failed (destination node not in network)
00000108 hex	Transmission failed (specified unit does not exist)
00000109 hex	Transmission failed (destination busy)
0000010A hex	Transmission failed (communication controller error)
0000010B hex	Transmission failed (PLC error)
0000010C hex	Transmission failed (unit number incorrect)
0000010D hex	Transmission failed (no destination address in routing table)
0000010E hex	Transmission failed (routing table not registered)
0000010F hex	Transmission failed (routing table error)
00000110 hex	Transmission failed (too many relay points)
00000111 hex	Transmission failed (command packet too long)
00000112 hex	Transmission failed (header error)
00000113 hex	Transmission failed (I/O setting error)
00000114 hex	Transmission failed (CPU Bus error)
00000115 hex	Transmission failed (redundant I/O allocations)
00000116 hex	Transmission failed (CPU Bus Unit error)
00000117 hex	Internal buffer full
00000118 hex	Illegal packet discarded
00000119 hex	Transmission failed (local node busy)
0000011A hex	Packets discarded due to initialization
0000011B hex	Packets discarded due to parity error
0000011C hex	Packets discarded due to framing error
0000011D hex	Packets discarded due to overrun error
0000011E hex	Packets discarded due to FCS error
0000011F hex	Packets discarded due to break detection
00000120 hex	Unexpected routing error
00000121 hex	Packet discarded (no setting in IP address table)
00000122 hex	Packet discarded (service not supported in current mode)
00000123 hex	Packet discarded (internal send buffer full)
00000124 hex	Routing failed (maximum frame size exceeded)

Event code	Error name
00000125 hex	Packet discarded (response timeout)
00000201 hex	Network parameter file loss
00000202 hex	Network parameter file destroyed
00000203 hex	EEPROM error
00000206 hex	Participating nodes decreased (local node still participating)
00000207 hex	Participating nodes decreased (local node not participating)
00000208 hex	Polling node changed
00000209 hex	Inconsistent network parameter
0000020A hex	RESET error
0000020B hex	SELF-TEST error completed
0000020C hex	Time out with token
0000020D hex	Time out with polling
0000020E hex	Communication chip controller WDT error
0000020F hex	Communication chip controller chip error
00000210 hex	Communications controller send error
00000211 hex	Duplicate address error
00000212 hex	Transceiver error
00000213 hex	Server demon startup error
00000214 hex	Node address setting error
00000215 hex	Network participation failed
00000216 hex	Backup power supply error (optical units only)
00000217 hex	Loop error
00000218 hex	Message send error
00000219 hex	Network status unstable
0000021A hex	Logic error in setting table
0000021B hex	Hardware error
0000021C hex	Datalink error inactive
0000021D hex	Datalink table communications cycle time setting error
0000021E hex	Network disconnection occurred
00000220 hex	Participating nodes reduced (removed node information)
00000221 hex	Participating nodes reduced (removed node information)
00000222 hex	Participating nodes reduced (removed node information)
00000223 hex	Participating nodes reduced (removed node information)
00000230 hex	Data link stop requested
000002B0 hex	FALS detected
00000300 hex	Packet Discarded (Parameter Error), Out of Range, or Flash failure
00000301 hex	Protocol macro operation error
00000302 hex	Packet discarded due to protocol violation
00000303 hex	Invalid DM setting
00000304 hex	Sensor error
00000305 hex	Invalid unit type
00000310 hex	Invalid BCD-code, or System parameter destroyed
00000311 hex	Program destroyed
00000312 hex	G unjust instruction
00000313 hex	Program range exceeded
00000314 hex	Origin signal
00000315 hex	Deviation counter over flow
00000316 hex	ABS data error
00000317 hex	No origin proximity
00000318 hex	CW direction over travelled
00000319 hex	CCW direction over travelled
0000031A hex	Both direction over travelled
0000031B hex	Current position counter over flow

Event code	Error name
0000031C hex	ABS multiple rotation error
0000031D hex	Field back pulse error
00000320 hex	PARUSU RE-TO RENJI FUSEI
00000330 hex	Invalid Range Limits(s)/Comparison Value, or Low battery
00000331 hex	Duplicate Target Error
00000335 hex	Duplicate Rate Range Error
00000340 hex	Bus Off detected
00000341 hex	Network power supply error
00000342 hex	Transmission timeout
00000343 hex	Structure error
00000344 hex	Verification error
00000345 hex	Remote I/O communications error
00000346 hex	Remote I/O communications stopped (remote I/O communications error)
00000347 hex	I/O refreshing error
00000348 hex	Message discarded (new request was received)
00000350 hex	Invalid Control Code, or NC unit error
00000351 hex	X-axis error
00000352 hex	Y-axis error
00000353 hex	Z-axis error
00000354 hex	U-axis error
00000360 hex	Invalid number of words, or Unit system error
00000370 hex	Verification error (OUT slave missing)
00000371 hex	Verification error (IN slave missing)
00000372 hex	Verification error (Unregistered OUT slave participating)
00000373 hex	Verification error (Unregistered IN slave participating)
00000374 hex	Communicaitons error
00000375 hex	Communication stopped due to communications error
00000376 hex	Address duplication error
00000378 hex	Illegal Repeater Unit/configuration error
000003B0 hex	DM system setting read error
000003B1 hex	Commands error
000003B2 hex	GP-IB I/F error
000003B3 hex	GP-IB send time out error
000003B4 hex	GP-IB receive time out error
000003C0 hex	Lower-Level Communication Error or FINS/TCP settings error,
000003C1 hex	Server settings error
000003C2 hex	FINS/TCP packets discarded
000003C3 hex	FINS/UDP packets discarded
000003C4 hex	Server connection error
000003C5 hex	Mail maintenance function error
000003C6 hex	Clock information write error
000003D0 hex	Ethernet basic setting error
000003D1 hex	Ethernet advanced setting error
000003D2 hex	Packet discarded
000003D3 hex	Link OFF error
000003D4 hex	Verification error (Tag data link)
000003D5 hex	Tag data link error
00000400 hex	Setting of Reset with Z-Phase
00000412 hex	Invalid Count Range
00000413 hex	Invalid Counter Present Value
00000420 hex	Invalid Rate Range Limits
00000430 hex	Invalid Range Limits(s) / Comparison Value
00000431 hex	Duplicate Target Error

Event code	Error name
00000435 hex	Duplicate Rate Range Error
00000450 hex	Overflow
00000460 hex	Underflow
00000470 hex	Invalid Preset Value
00000480 hex	External Interrupt Task Buffer Full
00000490 hex	Parity error/Not Ready/Time-out
00000500 hex	System call error (address error)
00000501 hex	System call error (parameter error)
00000502 hex	System call error (error in the board)
00000503 hex	System call error (block error)
00000504 hex	System call error (command error)
00000505 hex	Message send failed
00000510 hex	Comm server startup condition file loss
00000511 hex	Comm server startup condition file undefined
00000512 hex	Comm server startup failed
00000513 hex	Temperature error
00000514 hex	Low battery voltage
00000515 hex	HDD-0 error
00000516 hex	HDD-1 error
00000517 hex	Message send failed
00000601 hex	CPU Bus Unit error
00000602 hex	CPU Bus Unit memory error
00000701 hex	Configuration error
00000702 hex	I/O area overlap
00000703 hex	I/O area range exceeded
00000704 hex	Unsupported slave
00000705 hex	Verification error (slave missing)
00000706 hex	Verification error (slave I/O size differs)
00000707 hex	Communication error
00000708 hex	Scan list operation failed
00000709 hex	PLC mounting error
00000781 hex	Node address duplication
00000782 hex	Bus Off detected
00000783 hex	No communications power supply
00000784 hex	Send timeout

3-3 Events in Order of Event Codes

This section provides a table of all events in order of the event codes. Events that are not errors are also given in the tables.

3-3-1 Interpreting Error Descriptions

The contents of the error table is described below.

Item	Description
Event code	The event code of the error in the NJ/NX-series Controller is given. The codes are given in eight hexadecimal digits.
Event name	The name of the event is given
Functional classification	A functional classification of the source is given.
Reference	The catalog number of the manual that provides details on the event are given.

Refer to information for the specified functional classification of the error in the error descriptions in the manual given in the *Reference* column in the tables for detailed information on an error.

The manual names are given below for the catalog numbers.

Cat. No.	Manual name
W500	NJ-series CPU Unit Hardware User's Manual
W501	NJ/NX-series CPU Unit Software User's Manual
W502	NJ/NX-series Instructions Reference Manual
W521	NX-series Digital I/O Units User's Manual
W522	NX-series Analog I/O Units User's Manual for Analog Input Units and Analog Output Units
W523	NX-series System Units User's Manual
W527	NJ/NX-series Database Connection CPU Units User's Manual
W528	NJ-series SECS/GEM CPU Units User's Manual (NJ501-1340)
W535	NX-series CPU Unit Hardware User's Manual
W539	NJ-series NJ Robotics CPU Unit User's Manual
W540	NX-series Communications Interface Units User's Manual
W565	NX-series Load Cell Input Unit User's Manual
W566	NX-series Analog I/O Units User's Manual for Temperature Input Units and Heater Burnout Detection Units
W578	NX-series NX1P2 CPU Unit Hardware User's Manual
W579	NX-series NX1P2 CPU Unit Built-in I/O and Option Board User's Manual
W490	CJ-series Analog I/O Units Operation Manual for NJ-series CPU Unit
W491	CJ-series Temperature Control Units Operation Manual for NJ-series CPU Unit
W492	CJ-series High-speed Counter Units Operation Manual for NJ-series CPU Unit
W498	CJ-series Analog I/O Units Operation Manual for NJ-series CPU Unit
W488	GX-series EtherCAT Slave Units User's Manual
W493	CJ-series CompoNet Master Units Operation Manual for NJ-series CPU Unit
W494	CJ-series Serial Communications Units Operation Manual for NJ-series CPU Unit
W495	CJ-series EtherNet/IP Units Operation Manual for NJ-series CPU Unit
W497	CJ-series DeviceNet Units Operation Manual for NJ-series CPU Unit
W505	NJ/NX-series CPU Unit Built-in EtherCAT Port User's Manual

Cat. No.	Manual name
W506	NJ/NX-series CPU Unit Built-in EtherNet/IP Port User's Manual
W519	NX-series EtherCAT Coupler Unit User's Manual
W570	IO-Link System User's Manual
W588	NJ-series CPU Unit OPC UA User's Manual
I574	MX2/RX Series Inverter EtherCAT Communication Unit User's Manual
W507	NJ/NX-series CPU Unit Motion Control User's Manual
W508	NJ/NX-series Motion Control Instructions Reference Manual
I576	AC Servomotors/Servo Drives G5 Series with Built-in EtherCAT Communications User's Manual
I577	AC Servomotors/Servo Drives G5-series with Built-in EtherCAT Communications Linear Motor Type User's Manual
W524	NX-series Position Interface Units User's Manual
I586	AC Servomotors/Servo Drives 1S-series with Built-in EtherCAT Communications User's Manual
O030	NJ/NY-series NC Integrated Controller User's Manual
E413	EtherCAT Digital-type Sensor Communications Unit Operation Manual
E429	EtherCAT Digital Sensor Communications Unit Operation Manual
Z317	CJ-series ID Sensor Units Operation Manual for NJ-series CPU Unit
Z314	FQ-M-series Specialized Vision Sensor for Positioning User's Manual
Z342	FH/FZ5 Vision System FH/FZ5 Series User's Manual for Communications Settings
Z332	ZW-CE1□T Confocal Fiber Type Displacement Sensor User's Manual
Z930	NX-series Safety Control Unit User's Manual

3-3-2 Error Table

Event code	Event name	Functional classification	Reference
00070000 hex	Real-Time Clock Stopped	Errors for Self Diagnosis	W500, W535, W578
00080000 hex	Real-Time Clock Failed	Errors for Self Diagnosis	W500, W535, W578
00090000 hex	DIP Switch Setting Error	Errors for Self Diagnosis	W500, W535, W578
000B0000 hex	Low Battery Voltage	Errors for Self Diagnosis	W500, W535, W578
000C0000 hex	CPU Unit Overheat	Errors for Self Diagnosis	W500, W535
000D0000 hex	Internal Bus Check Error	Errors for Self Diagnosis	W500, W535, W578
000E0000 hex	Non-volatile Memory Life Exceeded	Errors for Self Diagnosis	W500, W535, W578
000F0000 hex	SD Memory Card Invalid Type	Errors for Self Diagnosis	W500, W535, W578
00100000 hex	SD Memory Card Life Exceeded	Errors for Self Diagnosis	W500, W535, W578
00110000 hex	CPU Unit Overheat (Operation Stopped)	Errors for Self Diagnosis	W535
00120000 hex	Slow Fan	Errors for Self Diagnosis	W535
00130000 hex	Main Memory Check Error	Errors for Self Diagnosis	W535, W578

Event code	Event name	Functional classification	Reference
00200000 hex	Non-volatile Memory Hardware Error	NX-series Digital I/O Units, NX-series Analog I/O Units, NX-series System Units, NX-series Position Interface Units, NX-series Communications Interface Units, NX-series Load Cell Input Units, and NX-series IO-Link Master Units	W521, W522, W566, W523, W524, W540, W565, W570
00210000 hex	Bus Controller Error	NX-series EtherCAT Coupler Unit	W519
00220000 hex	Non-volatile Memory Hardware Error	NX-series EtherCAT Coupler Unit	W519
04010000 hex	I/O Bus Check Error	Errors Related to CJ-series Unit Configuration	W500
04020000 hex	PLC System Information	Errors Related to CJ-series Unit Configuration	W500
04100000 hex	NX Bus Controller Error	NX Bus	W501, W578
04110000 hex	NX Bus Hardware Error	NX Bus	W501, W578
04200000 hex	Communications Controller Failure	Built-in EtherNet/IP Port on CPU Unit	W506
04210000 hex	Communications Controller Failure	Built-in EtherNet/IP Port on CPU Unit	W506
04400000 hex	Communications Controller Failure	Built-in EtherCAT Master in CPU Unit	W505
04600000 hex	A/D Conversion Error	CJ-series Analog I/O Units and CJ-series Process I/O Units	W490, W498
04610000 hex	Cold Junction Sensor Error	CJ-series Process I/O Units	W498
04620000 hex	Non-volatile Memory Error	CJ-series Analog I/O Units and CJ-series Process I/O Units	W490, W498
04680000 hex	Cold Junction Sensor Error	CJ-series Temperature Control Units	W491
046C0000 hex	Unit Status, Antenna Power Supply Error	CJ-series ID Sensor Units	Z317
046D0000 hex	Unit Status, Memory Error	CJ-series ID Sensor Units	Z317
046E0000 hex	Results Information, Antenna Error	CJ-series ID Sensor Units	Z317
046F0000 hex	Unit Status, Unit Busy	CJ-series ID Sensor Units	Z317
04740000 hex	Error Log Data Error	CJ-series Serial Communications Units	W494
04750000 hex	DTR Check Error	CJ-series Serial Communications Units	W494
04760000 hex	CTS Check Error	CJ-series Serial Communications Units	W494
047A0000 hex	Unit Memory Error (Device Error)	CJ-series EtherNet/IP Units	W495
047B0000 hex	Non-volatile Memory Error	CJ-series EtherNet/IP Units	W495
047C0000 hex	Communications Controller Error	CJ-series EtherNet/IP Units	W495
04880000 hex	Unit Memory Error	CJ-series DeviceNet Units	W497
04890000 hex	Network Power Error	CJ-series DeviceNet Units	W497
048A0000 hex	File Read/Write Error	CJ-series DeviceNet Units	W497
04A00000 hex	Expansion Unit Hardware Error	GX-series EtherCAT Slave Units	W488
04A10000 hex	Non-volatile Memory Hardware Error	GX-series EtherCAT Slave Units, MX2/RX-series Inverters with EtherCAT Communications Units, EtherCAT M3X Photoelectric Fiber Amplifiers, E3X-series Fiber Sensors with EtherCAT Communications Unit for Digital Sensors, and EtherCAT Digital Sensor Communications Units	W488, I574, E413, E429, W570
04A20000 hex	Slave Hardware Error	GX-series EtherCAT Slave Units	W488, W570

Event code	Event name	Functional classification	Reference
04A80000 hex	Control Power Supply Undervoltage	Servo G5 and G5 Linear	I576, I577
04A90000 hex	Overvoltage	Servo G5 and G5 Linear	I576, I577
04AA0000 hex	Main Circuit Power Supply Undervoltage (Undervoltage between positive and negative terminals)	Servo G5 and G5 Linear	I576, I577
04AB0000 hex	Main Circuit Power Supply Undervoltage (AC Cutoff Detected)	Servo G5 and G5 Linear	I576, I577
04AC0000 hex	Overcurrent	Servo G5 and G5 Linear	I576, I577
04AD0000 hex	IPM Error	Servo G5 and G5 Linear	I576, I577
04AE0000 hex	Regeneration Tr Error	Servo G5 and G5 Linear	I576, I577
04AF0000 hex	Encoder Phase-Z Error	Servo G5	I576
04B00000 hex	Encoder CTS Signal Error	Servo G5	I576
04B10000 hex	Node Address Setting Error	Servo G5 and G5 Linear	I576, I577
04B20000 hex	Other Errors	G5 Linear	I577
04BA0000 hex	Connection Error between Inverter and Communications Unit	MX2/RX-series Inverters with EtherCAT Communications Units	I574
04BB0000 hex	Inverter Warning	MX2/RX-series Inverters with EtherCAT Communications Units	I574
04BC0000 hex	Inverter Trip	MX2/RX-series Inverters with EtherCAT Communications Units	I574
04C40000 hex	Sensor Communications Error	E3X-series Fiber Sensors with EtherCAT Communications Unit for Digital Sensors and EtherCAT Digital Sensor Communications Units	E413, E429
04C50000 hex	Sensor Communications Has Not Been Established	E3X-series Fiber Sensors with EtherCAT Communications Unit for Digital Sensors and EtherCAT Digital Sensor Communications Units	E413, E429
04D00000 hex	Hardware Error	ZW-CE1□T Confocal Fiber Type Displacement Sensor	Z332
05010000 hex	ESC Error	NX-series EtherCAT Coupler Unit	W519
05020000 hex	ESC Initialization Error	NX-series EtherCAT Coupler Unit	W519
05030000 hex	Slave Unit Verification Error	NX-series EtherCAT Coupler Unit	W519
05100000 hex	A/D Converter Error	NX-series Analog I/O Units	W566
05110000 hex	Cold Junction Sensor Error	NX-series Analog I/O Units	W566
05120000 hex	A/D Conversion Error	NX-series Load Cell Input Units	W565
05200000 hex	System Error	NX-series Safety Control Unit	Z930
05210000 hex	Internal Circuit Error at Safety Input	NX-series Safety Control Unit	Z930
05220000 hex	Internal Circuit Error at Test Output	NX-series Safety Control Unit	Z930
05230000 hex	Internal Circuit Error at Safety Output	NX-series Safety Control Unit	Z930
05430000 hex	ESC Error	Servo 1S	I586
05440000 hex	Option Board Error	Built-in I/O and Option Boards	W579
08010000 hex	Battery Warning	Servo G5	I576
08020000 hex	Fan Warning	Servo G5 and G5 Linear	I576, I577
08030000 hex	Encoder Communications Warning	Servo G5	I576
08040000 hex	Encoder/Serial Conversion Unit Overheating Warning	Servo G5 and G5 Linear	I576, I577
08050000 hex	Life Expectancy Warning	Servo G5 and G5 Linear	I576, I577
08060000 hex	External Encoder Error Warning	Servo G5 and G5 Linear	I576, I577

Event code	Event name	Functional classification	Reference
08070000 hex	External Encoder Communications Warning	Servo G5 and G5 Linear	I576, I577
08080000 hex	Encoder Communications Disconnection Error	Servo G5	I576
08090000 hex	Encoder Communications Error	Servo G5	I576
080A0000 hex	Encoder Communications Data Error	Servo G5	I576
080B0000 hex	Safety Input Error	Servo G5 and G5 Linear	I576, I577
080C0000 hex	External Encoder Connection Error	Servo G5 and G5 Linear	I576, I577
080D0000 hex	External Encoder Communications Data Error	Servo G5 and G5 Linear	I576, I577
080E0000 hex	External Encoder Status Error 0	Servo G5 and G5 Linear	I576, I577
080F0000 hex	External Encoder Status Error 1	Servo G5 and G5 Linear	I576, I577
08100000 hex	External Encoder Status Error 2	Servo G5 and G5 Linear	I576, I577
08110000 hex	External Encoder Status Error 3	Servo G5 and G5 Linear	I576, I577
08120000 hex	External Encoder Status Error 4	Servo G5 and G5 Linear	I576, I577
08130000 hex	External Encoder Status Error 5	Servo G5 and G5 Linear	I576, I577
08140000 hex	Phase-A Connection Error	Servo G5 and G5 Linear	I576, I577
08150000 hex	Phase-B Connection Error	Servo G5 and G5 Linear	I576, I577
08160000 hex	Phase-Z Connection Error	Servo G5 and G5 Linear	I576, I577
08170000 hex	Encoder Data Restoration Error	Servo G5	I576
08180000 hex	External Encoder Data Restoration Error	Servo G5	I576
081C0000 hex	Capacitor Lifetime Warning	Servo 1S	I586
081D0000 hex	Inrush Current Prevention Relay Lifetime Warning	Servo 1S	I586
081F0000 hex	Brake Interlock Output Relay Lifetime Warning	Servo 1S	I586
08210000 hex	Fan/Power Supply Error	FH/FZ5 Series Vision System	Z342
08220000 hex	Camera Overcurrent Detected	FH/FZ5 Series Vision System	Z342
08230000 hex	Parallel I/O Overcurrent Detected	FH/FZ5 Series Vision System	Z342
08390000 hex	Power Module Error	Servo 1S	I586
083A0000 hex	Encoder Communications Warning	Servo 1S	I586
083B0000 hex	Self-diagnosis Error	Servo 1S	I586
083C0000 hex	Main Circuit Temperature Monitoring Circuit Failure	Servo 1S	I586
083D0000 hex	Fan Error	Servo 1S	I586
083F0000 hex	Regeneration Processing Error	Servo 1S	I586
08410000 hex	Overvoltage Error	Servo 1S	I586
08420000 hex	Motor Overheat Error	Servo 1S	I586
08430000 hex	1-rotation Counter Error	Servo 1S	I586
08440000 hex	Overspeed Error	Servo 1S	I586
08450000 hex	Encoder Memory Error	Servo 1S	I586
08460000 hex	Absolute Position Detection Error	Servo 1S	I586
08470000 hex	Encoder Lifetime Warning	Servo 1S	I586
08480000 hex	Main Power Supply Undervoltage (insufficient voltage between P and N)	Servo 1S	I586
08490000 hex	Overcurrent Error	Servo 1S	I586

Event code	Event name	Functional classification	Reference
084A0000 hex	Encoder Communications Disconnection Error	Servo 1S	I586
084B0000 hex	Encoder Communications Error	Servo 1S	I586
084C0000 hex	Fan Rotation Warning	Servo 1S	I586
084D0000 hex	Non-volatile Memory Hardware Error	Servo 1S	I586
084E0000 hex	Absolute Encoder Counter Overflow Warning	Servo 1S	I586
10010000 hex	Non-volatile Memory Restored or Formatted	Errors for Self Diagnosis	W500, W535, W578
10020000 hex	Non-volatile Memory Data Corrupted	Errors for Self Diagnosis	W500, W535, W578
10030000 hex	SD Memory Card Invalid Format	Errors for Self Diagnosis	W500, W535, W578
10040000 hex	SD Memory Card Restored or Formatted	Errors for Self Diagnosis	W500, W535, W578
10060000 hex	SD Memory Card Data Corrupted	Errors for Self Diagnosis	W500, W535, W578
10070000 hex	SD Memory Card Access Power OFF Error	Errors for Self Diagnosis	W500, W535, W578
10080000 hex	Main Memory Check Error	Errors for Self Diagnosis	W500, W535, W578
10090000 hex	Battery-backup Memory Check Error	Errors for Self Diagnosis	W500, W535
100A0000 hex	Data Not Saved to Battery-backup Memory	Errors for Self Diagnosis	W500, W535
100B0000 hex	Non-volatile Memory Data Corrupted	Errors for Self Diagnosis	W500, W535, W578
100C0000 hex	Event Level Setting Error	Errors for Self Diagnosis	W500, W535, W578
100F0000 hex	Present Values of Retained Variables Restoration Error	Errors for Self Diagnosis	W578
10100000 hex	Present Values of Retained Variables Not Saved	Errors for Self Diagnosis	W578
10130000 hex	PLC System Information	Errors for Self Diagnosis	W578
10200000 hex	User Program/Controller Configurations and Setup Transfer Error	Errors Related to Controller Operation	W500, W501, W535, W578
10210000 hex	Illegal User Program Execution ID	Errors Related to Controller Operation	W500, W501, W535, W578
10230000 hex	Event Log Save Error	Errors Related to Controller Operation	W500, W501, W535, W578
10240000 hex	Illegal User Program	Errors Related to Controller Operation	W500, W501, W535, W578
10250000 hex	Illegal User Program/Controller Configurations and Setup	Errors Related to Controller Operation	W500, W501, W535, W578
10260000 hex	Trace Setting Transfer Failure	Errors Related to Controller Operation	W500, W501, W535, W578
10270000 hex	Error in Starting Automatic Transfer	Errors Related to Controller Operation	W500, W501, W535, W578
10280000 hex	Error in Executing Automatic Transfer	Errors Related to Controller Operation	W500, W501, W535, W578
10290000 hex	Backup Failed to Start	Errors Related to Controller Operation	W500, W501, W535, W578
102A0000 hex	Backup Failed	Errors Related to Controller Operation	W500, W501, W535, W578

Event code	Event name	Functional classification	Reference
102B0000 hex	Restore Operation Failed to Start	Errors Related to Controller Operation	W500, W501, W535, W578
102C0000 hex	Restore Operation Failed	Errors Related to Controller Operation	W500, W501, W535, W578
102D0000 hex	CJ-series Unit Backup Failed	Errors Related to CJ-series Unit Configuration	W500
102E0000 hex	CJ-series Unit Restore Operation Failed	Errors Related to CJ-series Unit Configuration	W500
102F0000 hex	EtherCAT Slave Backup Failed	Built-in EtherCAT Master in CPU Unit	W505
10300000 hex	EtherCAT Slave Restore Operation Failed	Built-in EtherCAT Master in CPU Unit	W505
10310000 hex	Incorrect SD Memory Card Removal	Errors for Self Diagnosis	W500, W535, W578
10320000 hex	SD Memory Card Program Transfer Failed to Start	Errors Related to Controller Operation	W500, W501, W535, W578
10330000 hex	SD Memory Card Program Transfer Pre-execution Check Error	Errors Related to Controller Operation	W500, W501, W535, W578
10340000 hex	Error in Executing SD Memory Card Program Transfer	Errors Related to Controller Operation	W500, W501, W535, W578
103C0000 hex	NX Unit Backup Failed	NX Bus	W501, W578
103D0000 hex	NX Unit Restore Operation Failed	NX Bus	W501, W578
103E0000 hex	Restore Pre-execution Check Failure	Errors Related to Controller Operation	W500, W501, W535, W578
10400000 hex	Analog Unit Calibration Parameter Error	NX-series Analog I/O Units	W522
10410000 hex	Control Parameter Error in Master	NX-series Digital I/O Units, NX-series Analog I/O Units, NX-series Position Interface Units, NX-series Communications Interface Units, NX-series Load Cell Input Units, and NX-series IO-Link Master Units	W521, W522, W566, W524, W540, W565, W570
10420000 hex	Non-volatile Memory Control Parameter Error	NX-series EtherCAT Coupler Unit	W519
10430000 hex	Memory Corruption Detected	NX-series EtherCAT Coupler Unit	W519
10440000 hex	Unit Calibration Value Error	NX-series Load Cell Input Units	W565
10450000 hex	Actual Load Calibration Value Error	NX-series Load Cell Input Units	W565
10500000 hex	NX Bus Communications Settings Read Error	NX-series Safety Control Unit	Z930
10510000 hex	Safety Application Data Read Error	NX-series Safety Control Unit	Z930
10520000 hex	NX Bus Communications Settings and Safety Application Data Mismatch	NX-series Safety Control Unit	Z930
10530000 hex	Non-volatile Memory Access Error	NX-series Safety Control Unit	Z930
10600000 hex	NX Bus Memory Check Error	NX Bus	W501, W578
10610000 hex	Failed to Read NX Unit Operation Settings	NX Bus	W501, W578
10620000 hex	NX Unit Event Log Save Error	NX Bus	W501, W578
14010000 hex	CPU Bus Unit Setup Area Error	Errors Related to FINS Communications	W501
14200000 hex	MAC Address Error	Built-in EtherNet/IP Port on CPU Unit	W506
14210000 hex	Identity Error	Built-in EtherNet/IP Port on CPU Unit	W506
14220000 hex	EtherNet/IP Processing Error	Built-in EtherNet/IP Port on CPU Unit	W506

Event code	Event name	Functional classification	Reference
14230000 hex	MAC Address Error	Built-in EtherNet/IP Port on CPU Unit	W506
14400000 hex	MAC Address Error	Built-in EtherCAT Master in CPU Unit	W505
14600000 hex	Absolute Encoder Home Offset Read Error	General Motion Control	W507
14610000 hex	Motion Control Parameter Setting Error	General Motion Control	W507
14620000 hex	Cam Data Read Error	General Motion Control	W507
14630000 hex	Cam Table Save Error	General Motion Control	W507
14800000 hex	Protocol Data Error	CJ-series Serial Communications Units	W494
14840000 hex	Invalid Communications Parameter	CJ-series EtherNet/IP Units	W495
14850000 hex	Tag Database Error	CJ-series EtherNet/IP Units	W495
148C0000 hex	Invalid Message Timer List Error	CJ-series DeviceNet Units	W497
148D0000 hex	Invalid Scan List Data	CJ-series DeviceNet Units	W497
148E0000 hex	Invalid Setup Data	CJ-series DeviceNet Units	W497
14A00000 hex	Non-volatile Memory Checksum Error	GX-series EtherCAT Slave Units, E3X-series Fiber Sensors with EtherCAT Communications Unit for Digital Sensors, and EtherCAT Digital Sensor Communications Units	W488, E413, E429, W570
14A80000 hex	Object Error	Servo G5 and G5 Linear	I576, I577
14A90000 hex	Object Error	Servo G5 and G5 Linear	I576, I577
14AA0000 hex	Object Error	Servo G5 and G5 Linear	I576, I577
14AB0000 hex	Object Corrupted	Servo G5 and G5 Linear	I576, I577
14AC0000 hex	Object Corrupted	Servo G5 and G5 Linear	I576, I577
14AD0000 hex	Object Corrupted	Servo G5 and G5 Linear	I576, I577
14B00000 hex	Linearity Correction Data Error	ZW-CE1□T Confocal Fiber Type Displacement Sensor	Z332
14B10000 hex	Linearity Correction Data Read Error	ZW-CE1□T Confocal Fiber Type Displacement Sensor	Z332
14B20000 hex	System Setting Error	ZW-CE1□T Confocal Fiber Type Displacement Sensor	Z332
14B30000 hex	Bank Data Error	ZW-CE1□T Confocal Fiber Type Displacement Sensor	Z332
14C00000 hex	Unit Calibration Value Parity Error	NX-series Analog I/O Units	W522
14D00000 hex	Spool Memory Corrupted	DB Connection Service	W527
14D20000 hex	Execution Log Save Filed	DB Connection Service	W527
14D30000 hex	SQL Execution Failure Log Save Failed	DB Connection Service	W527
14E00000 hex	Invalid GEM Setting Data	GEM Services	W528
14E10000 hex	GEM Service Log Save Failed	GEM Services	W528
14E20000 hex	Spool Data Discarded	GEM Services	W528
14E30000 hex	Spool Save Failed	GEM Services	W528
14E40000 hex	Invalid SD Memory Card	GEM Services	W528

Event code	Event name	Functional classification	Reference
15000000 hex	Execution Log Save Failed	OPC UA Server	W588
15020000 hex	Server Certificate Mismatch	OPC UA Server	W588
17800000 hex	CNC Parameter Setting Error	CNC Function	O030
17810000 hex	Absolute Encoder Home Offset Read Error	CNC Function	O030
17820000 hex	CNC Motor Compensation Table Read Error	CNC Function	O030
18200000 hex	Absolute Encoder Overspeed Error	Servo G5	I576
18210000 hex	Encoder Initialization Error	Servo G5	I576
18220000 hex	Absolute Encoder One-rotation Counter Error	Servo G5	I576
18230000 hex	Absolute Encoder Multi-rotation Counter Error	Servo G5 and Servo 1S	I576, I586
182D0000 hex	Setting Data Load Error	FH/FZ5 Series Vision System	Z342
18380000 hex	System Error	Servo 1S	I586
18390000 hex	Lifetime Information Corruption Warning	Servo 1S	I586
183A0000 hex	Non-volatile Memory Data Error	Servo 1S	I586
24010000 hex	Unsupported Unit Detected	Errors Related to CJ-series Unit Configuration	W500
24020000 hex	Too Many I/O Points	Errors Related to CJ-series Unit Configuration	W500
24030000 hex	End Cover Missing	Errors Related to CJ-series Unit Configuration	W500
24040000 hex	Incorrect Unit/Expansion Rack Connection	Errors Related to CJ-series Unit Configuration	W500
24050000 hex	Duplicate Unit Number	Errors Related to CJ-series Unit Configuration	W500
24200000 hex	Slave Node Address Duplicated	Built-in EtherCAT Master in CPU Unit	W505
24400000 hex	Unit Status, Antenna Error	CJ-series ID Sensor Units	Z317
24480000 hex	Node Address Duplicated Error	CJ-series DeviceNet Units	W497
24610000 hex	Switch Setting Error	GX-series EtherCAT Slave Units	W488
24680000 hex	Motor Non-conformity	Servo G5	I576
24690000 hex	Motor Non-conformity	Servo G5	I576
246A0000 hex	Motor Non-conformity	Servo G5	I576
246B0000 hex	Motor Non-conformity	Servo G5	I576
246C0000 hex	Motor Non-conformity	Servo G5	I576
246D0000 hex	Motor Non-conformity	Servo 1S	I586
24780000 hex	Number of Sensors Verify Error	E3X-series Fiber Sensors with EtherCAT Communications Unit for Digital Sensors	E413
24790000 hex	Number of Sensors Over Limit	E3X-series Fiber Sensors with EtherCAT Communications Unit for Digital Sensors	E413

Event code	Event name	Functional classification	Reference
247A0000 hex	Number of Distributed Sensor Unit Verify Error	EtherCAT Digital Sensor Communications Units	E429
247B0000 hex	Number of Sensors Over Limit	EtherCAT Digital Sensor Communications Units	E429
247C0000 hex	Number of Sensors Verify Error	EtherCAT Digital Sensor Communications Units	E429
247D0000 hex	Number of Sensors Over at Distributed Sensor Unit	EtherCAT Digital Sensor Communications Units	E429
24810000 hex	Ethernet Communications Parameter Error	ZW-CE1□T Confocal Fiber Type Displacement Sensor	Z332
24A00000 hex	Unit Configuration Error, Too Many Units	NX-series EtherCAT Coupler Unit	W519
24A10000 hex	Unit Configuration Error, Unsupported Configuration	NX-series EtherCAT Coupler Unit	W519
24D00000 hex	Number of Mountable NX Units Exceeded	NX Bus	W501, W578
24D20000 hex	Total I/O Data Size in NX Units Excessive	NX Bus	W501, W578
28010000 hex	Motor Setting Error	G5 Linear	I577
28020000 hex	Motor Combination Error 1	G5 Linear	I577
28030000 hex	Motor Combination Error 2	G5 Linear	I577
28080000 hex	Main Circuit Power Supply Phase Loss Error	Servo 1S	I586
280D0000 hex	Runaway Detected	Servo 1S	I586
30200000 hex	Unsupported Unit Setting	Errors Related to CJ-series Unit Configuration	W500
34010000 hex	I/O Setting Check Error	Errors Related to CJ-series Unit Configuration	W500
34100000 hex	IP Address Table Setting Error	Errors Related to FINS Communications	W501
34110000 hex	Unknown Destination Node	Errors Related to FINS Communications	W501
34130000 hex	FINS/TCP Connection Table Setting Error	Errors Related to FINS Communications	W501
34200000 hex	Tag Data Link Setting Error	Built-in EtherNet/IP Port on CPU Unit	W506
34210000 hex	Basic Ethernet Setting Error	Built-in EtherNet/IP Port on CPU Unit	W506
34220000 hex	IP Address Setting Error	Built-in EtherNet/IP Port on CPU Unit	W506
34230000 hex	IP Route Table Setting Error	Built-in EtherNet/IP Port on CPU Unit	W506
34240000 hex	FTP Server Setting Error	Built-in EtherNet/IP Port on CPU Unit	W506
34250000 hex	NTP Client Setting Error	Built-in EtherNet/IP Port on CPU Unit	W506
34260000 hex	SNMP Setting Error	Built-in EtherNet/IP Port on CPU Unit	W506
34270000 hex	Tag Name Resolution Error	Built-in EtherNet/IP Port on CPU Unit	W506
34280000 hex	Basic Ethernet Setting Error	Built-in EtherNet/IP Port on CPU Unit	W506
34290000 hex	IP Address Setting Error	Built-in EtherNet/IP Port on CPU Unit	W506
342A0000 hex	DNS Setting Error	Built-in EtherNet/IP Port on CPU Unit	W506
34400000 hex	Network Configuration Information Error	Built-in EtherCAT Master in CPU Unit	W505
34410000 hex	EtherCAT Communications Cycle Exceeded	Built-in EtherCAT Master in CPU Unit	W505

Event code	Event name	Functional classification	Reference
34600000 hex	Required Process Data Object Not Set	General Motion Control	W507
34610000 hex	Process Data Object Setting Missing	Motion Control Instructions	W508
34630000 hex	Axis Slave Disabled	General Motion Control	W507
34640000 hex	Network Configuration Information Missing for Axis Slave	General Motion Control	W507
34800000 hex	Mean Value Processing Setting Error	CJ-series Analog I/O Units	W490
34810000 hex	Input Value Exceeded Adjustment Range in Adjustment Mode	CJ-series Analog I/O Units	W490
34820000 hex	Input Number Specification Error in Adjustment Mode	CJ-series Analog I/O Units	W490
34830000 hex	Scaling Data Setting Error	CJ-series Analog I/O Units	W490
34840000 hex	Input Signal Range Setting Error or Error in Number of Inputs Setting	CJ-series Analog I/O Units	W490
34850000 hex	Mean Value Processing Setting Error	CJ-series Analog I/O Units	W490
34860000 hex	Error in Setting of Conversion Mode	CJ-series Analog I/O Units	W490
34870000 hex	Output Hold Setting Error	CJ-series Analog I/O Units	W490
34880000 hex	Output Number Specification Error in Adjustment Mode	CJ-series Analog I/O Units	W490
34890000 hex	Conversion Time/Resolution or Operation Mode Setting Error	CJ-series Analog I/O Units	W490
348A0000 hex	Output Signal Range Setting Error or Error In Number of Outputs Used Setting	CJ-series Analog I/O Units	W490
348C0000 hex	I/O Number Specification Error in Adjustment Mode	CJ-series Analog I/O Units	W490
348D0000 hex	Data Range Error	CJ-series Process I/O Units	W498
34940000 hex	Setting Error	CJ-series Temperature Control Units	W491
34980000 hex	Results Information, Data Storage Area Specification Error	CJ-series ID Sensor Units	Z317
349C0000 hex	Registration Table Verification Error	CJ-series CompoNet Master Unit	W493
349D0000 hex	Slave Unit Duplicated Address Error	CJ-series CompoNet Master Unit	W493
349E0000 hex	Repeater Unit Node Duplicated Address Error	CJ-series CompoNet Master Unit	W493
34A40000 hex	System Setup Error	CJ-series Serial Communications Units	W494
34A80000 hex	Verification Error	CJ-series EtherNet/IP Units	W495
34A90000 hex	Tag Data Link Error	CJ-series EtherNet/IP Units	W495
34AA0000 hex	Tag Refresh Error	CJ-series EtherNet/IP Units	W495
34AB0000 hex	Basic Ethernet Setting Error	CJ-series EtherNet/IP Units	W495
34AC0000 hex	IP Address Table Error	CJ-series EtherNet/IP Units	W495
34AD0000 hex	IP Router Table Error	CJ-series EtherNet/IP Units	W495
34AE0000 hex	Routing Table Error	CJ-series EtherNet/IP Units	W495
34AF0000 hex	Ethernet Advanced Setting Error	CJ-series EtherNet/IP Units	W495
34B00000 hex	Address Mismatch	CJ-series EtherNet/IP Units	W495
34BC0000 hex	Routing Table Error	CJ-series DeviceNet Units	W497
34BD0000 hex	Verification Error	CJ-series DeviceNet Units	W497
34BE0000 hex	Structure Error	CJ-series DeviceNet Units	W497
34BF0000 hex	Master I/O Refresh Error	CJ-series DeviceNet Units	W497

Event code	Event name	Functional classification	Reference
34C00000 hex	Master User-set Allocations User Setting Failed	CJ-series DeviceNet Units	W497
34C10000 hex	Communications Cycle Time Setting Failed	CJ-series DeviceNet Units	W497
34C20000 hex	Slave I/O Refresh Error	CJ-series DeviceNet Units	W497
34C30000 hex	Slave User Allocation Area Setting Failed	CJ-series DeviceNet Units	W497
34E00000 hex	Data Setting Warning	Servo G5, G5 Linear, and Servo 1S	I576, I577, I586
34E10000 hex	Servo Drive Overheat	Servo G5 and G5 Linear	I576, I577
34E20000 hex	Overload	Servo G5 and G5 Linear	I576, I577
34E30000 hex	Regeneration Overload	Servo G5 and G5 Linear	I576, I577
34E40000 hex	Error Counter Overflow	Servo G5 and G5 Linear	I576, I577
34E50000 hex	Excessive Velocity Error	Servo G5 and G5 Linear	I576, I577
34E60000 hex	Overspeed	Servo G5 and G5 Linear	I576, I577
34F00000 hex	PDO Setting Error	MX2/RX-series Inverters with EtherCAT Communications Units	I574
34F80000 hex	Dummy Sensors Setting Error	E3X-series Fiber Sensors with EtherCAT Communications Unit for Digital Sensors, and EtherCAT Digital Sensor Communications Units	E413, E429
35000000 hex	Unit Configuration Information Error	NX-series EtherCAT Coupler Unit	W519
35010000hex	Unit Configuration Verification Error	NX-series EtherCAT Coupler Unit	W519
35020000hex	NX Unit Minor Fault	NX-series EtherCAT Coupler Unit	W519
35030000hex	NX Unit Observation	NX-series EtherCAT Coupler Unit	W519
35040000hex	Mailbox Setting Error	NX-series EtherCAT Coupler Unit	W519
35050000hex	RxPDO Setting Error	NX-series EtherCAT Coupler Unit	W519
35060000hex	TxPDO Setting Error	NX-series EtherCAT Coupler Unit	W519
35070000 hex	PDO WDT Setting Error	NX-series EtherCAT Coupler Unit	W519
35080000 hex	SM Event Mode Setting Error	NX-series EtherCAT Coupler Unit	W519
35090000 hex	TxPDO Mapping Error	NX-series EtherCAT Coupler Unit	W519
350A0000 hex	RxPDO Mapping Error	NX-series EtherCAT Coupler Unit	W519
350B0000 hex	Illegal State Transition Request Received	NX-series EtherCAT Coupler Unit	W519
350C0000 hex	Error State Transition Received	NX-series EtherCAT Coupler Unit	W519
350D0000 hex	Synchronization Cycle Setting Error	NX-series EtherCAT Coupler Unit	W519
350E0000 hex	NX Bus Cycle Delay Detected	NX-series EtherCAT Coupler Unit	W519
35100000 hex	External Input Setting Error	NX-series Position Interface Units	W524
35110000 hex	SSI Data Setting Error	NX-series Position Interface Units	W524

Event code	Event name	Functional classification	Reference
35200000 hex	Safety Process Data Communications Not Established Error	NX-series Safety Control Unit	Z930
35210000 hex	Safety Process Data Communications Not Established - Incorrect Unit Parameter Error	NX-series Safety Control Unit	Z930
35230000 hex	Safety Process Data Communications Not Established, Incorrect FSoE Slave Address Error	NX-series Safety Control Unit	Z930
35240000 hex	Safety Process Data Communications Not Established, Incorrect Frame Error	NX-series Safety Control Unit	Z930
35300000hex	DB Connection Setting Error	DB Connection Service	W527
35400000 hex	Illegal Variable Allocation	GEM Services	W528
35410000 hex	Illegal TCP Port Number	GEM Services	W528
357D0000 hex	DC Setting Error	Servo 1S	I586
357E0000 hex	Synchronization Cycle Setting Error	Servo 1S	I586
357F0000 hex	Mailbox Setting Error	Servo 1S	I586
35800000 hex	RxPDO Setting Error	Servo 1S	I586
35810000 hex	TxPDO Setting Error	Servo 1S	I586
35820000 hex	RxPDO Mapping Error	Servo 1S	I586
35830000 hex	TxPDO Mapping Error	Servo 1S	I586
35840000 hex	PDO WDT Setting Error	Servo 1S	I586
35850000 hex	Node Address Updated	Servo 1S	I586
35860000 hex	SM Event Mode Setting Error	Servo 1S	I586
35900000 hex	NX Unit Version Not Matched	NX Bus	W501, W578
35910000 hex	Unregistered NX Unit Mounted	NX Bus	W501, W578
35920000 hex	Registered NX Unit Not Mounted	NX Bus	W501, W578
35930000 hex	NX Unit Serial Number Mismatch	NX Bus	W501, W578
35940000 hex	Option Board Configuration Verification Error	NX Bus	W501, W578
35950000 hex	Unsupported Option Board Mounted	NX Bus	W501, W578
35D00000 hex	OPC UA Server Setting Error	OPC UA Server	W588
35D10000 hex	Server certificate Expired	OPC UA Server	W588
35D20000 hex	Server Certificate Expiration Notice	OPC UA Server	W588
35D30000 hex	Too Many Public Variables	OPC UA Server	W588
35D40000 hex	Unsupported Data Type	OPC UA Server	W588
35D50000 hex	Too Many Public Value Attributes	OPC UA Server	W588
35D60000 hex	Too Many Structure Definitions	OPC UA Server	W588
37800000 hex	Required Process Data Object Not Set	CNC Function	O030
37810000 hex	Process Data Object Setting Missing	CNC Function	O030
38010000 hex	Scaling Data Setting Error/Ratio Conversion Use Setting Error	CJ-series Analog I/O Units	W490
38020000 hex	Ratio Set Value Error	CJ-series Analog I/O Units	W490

Event code	Event name	Functional classification	Reference
381C0000 hex	Status Area Layout Setting Error	CJ-series EtherNet/IP Units	W495
383C0000 hex	Overload Warning	Servo G5 and G5 Linear	I576, I577
383D0000 hex	Excessive Regeneration Warning	Servo G5 and G5 Linear	I576, I577
383E0000 hex	Vibration Detection Warning	Servo G5 and G5 Linear	I576, I577
383F0000 hex	Excessive Hybrid Following Error	Servo G5	I576
38400000 hex	Overspeed 2	Servo G5 and G5 Linear	I576, I577
38410000 hex	Command Error	Servo G5 and G5 Linear	I576, I577
38420000 hex	Command Generation Error	Servo G5 and G5 Linear	I576, I577
38430000 hex	Error Counter Overflow 1	Servo G5 and G5 Linear	I576, I577
38440000 hex	Error Counter Overflow 2	Servo G5 and G5 Linear	I576, I577
38450000 hex	Interface Input Duplicate Allocation Error 1	Servo G5 and G5 Linear	I576, I577
38460000 hex	Interface Input Duplicate Allocation Error 2	Servo G5 and G5 Linear	I576, I577
38470000 hex	Interface Input Function Number Error 1	Servo G5 and G5 Linear	I576, I577
38480000 hex	Interface Input Function Number Error 2	Servo G5 and G5 Linear	I576, I577
38490000 hex	Interface Output Function Number Error 1	Servo G5 and G5 Linear	I576, I577
384A0000 hex	Interface Output Function Number Error 2	Servo G5 and G5 Linear	I576, I577
384B0000 hex	External Latch Input Allocation Error	Servo G5 and G5 Linear	I576, I577
384C0000 hex	Overrun Limit Error	Servo G5 and G5 Linear	I576, I577
384D0000 hex	Absolute Encoder System Down Error	Servo G5	I576
384E0000 hex	Absolute Encoder Counter Overflow Error	Servo G5	I576
384F0000 hex	Object Setting Error 1	Servo G5 and G5 Linear	I576
38500000 hex	Object Setting Error 2	Servo G5 and G5 Linear	I576
38510000 hex	External Encoder Connection Error	Servo G5 and G5 Linear	I576
38520000 hex	Function Setting Error	Servo G5 and G5 Linear	I576
38530000 hex	Magnetic Pole Position Estimation Error 1	Servo G5	I577
38540000 hex	Magnetic Pole Position Estimation Error 2	Servo G5	I577
38550000 hex	Magnetic Pole Position Estimation Error 3	Servo G5	I577
38560000 hex	Motor Auto-setting Error	Servo G5	I577
38570000 hex	Function Setting Error	Servo 1S	I586
38590000 hex	Camera Connection Error	FH/FZ5 Series Vision System	Z342
385A0000 hex	Change in Connected Camera	FH/FZ5 Series Vision System	Z342
385B0000 hex	Light installation error	FH/FZ5 Series Vision System	Z342

Event code	Event name	Functional classification	Reference
38780000 hex	General Input Allocation Duplicate Error	Servo 1S	I586
38790000 hex	General Output Allocation Duplicate Error	Servo 1S	I586
387A0000 hex	Overload Warning	Servo 1S	I586
387B0000 hex	Pulse Output Setting Error	Servo 1S	I586
387C0000 hex	Motor Replacement Detected	Servo 1S	I586
387D0000 hex	Regeneration Overload Warning	Servo 1S	I586
387E0000 hex	Motor Vibration Warning	Servo 1S	I586
387F0000 hex	Electronic Gear Setting Error	Servo 1S	I586
38800000 hex	Servo Drive Overheat	Servo 1S	I586
38810000 hex	Overload Error	Servo 1S	I586
38820000 hex	Regeneration Overload Error	Servo 1S	I586
38830000 hex	Excessive Position Deviation Error	Servo 1S	I586
38840000 hex	Excessive Speed Deviation Error	Servo 1S	I586
38850000 hex	Excessive Speed Error	Servo 1S	I586
38860000 hex	Following Error Counter Overflow	Servo 1S	I586
38870000 hex	Absolute Encoder Counter Overflow Error	Servo 1S	I586
38880000 hex	Safety Communications Setting Error	Servo 1S	I586
38890000 hex	Safety Frame Error	Servo 1S	I586
388A0000 hex	Safety Parameter Error	Servo 1S	I586
388B0000 hex	FSoE Slave Address Error	Servo 1S	I586
40010000 hex	PLC System Processing Error	Errors for Self Diagnosis	W500
40020000 hex	PLC System Processing Error	Errors for Self Diagnosis	W500, W535, W578
40030000 hex	PLC System Processing Error	Errors for Self Diagnosis	W500, W535, W578
40040000 hex	PLC System Processing Error	Errors for Self Diagnosis	W535, W578
40050000 hex	PLC System Processing Error	Errors for Self Diagnosis	W535, W578
40110000 hex	PLC Function Processing Error	Errors Related to Controller Operation	W500, W501, W535, W578
40120000 hex	PLC Function Processing Error	Errors Related to Controller Operation	W500, W501, W535, W578
40130000 hex	PLC Function Processing Error	Errors Related to Controller Operation	W500, W501, W535, W578
40140000 hex	PLC System Information	Errors Related to Controller Operation	W500, W501, W535, W578
40150000 hex	PLC System Information	Errors Related to Controller Operation	W500, W501, W535, W578
40160000 hex	Safe Mode	Errors Related to Controller Operation	W500, W501
40170000 hex	Safe Mode	Errors Related to Controller Operation	W500, W501, W535, W578
40200000 hex	NX Unit Processing Error	NX-series EtherCAT Coupler Units, NX-series Analog I/O Units, NX-series Position Interface Units, NX-series Communications Interface Units, NX-series Load Cell Input Units, and NX-series IO-Link Master Units	W519, W566, W524, W540, W565, W570

Event code	Event name	Functional classification	Reference
44010000 hex	EtherCAT Fault	Built-in EtherCAT Master in CPU Unit	W505
44180000 hex	OPC UA System Processing Error	OPC UA Server	W588
44200000 hex	Motion Control Initialization Error	General Motion Control	W507, W535
44210000 hex	Motion Control Function Processing Error	General Motion Control	W507
44400000 hex	PLC Function Processing Error	Errors Related to CJ-series Unit Configuration	W500
44410000 hex	PLC System Information	Errors Related to CJ-series Unit Configuration	W500
44420000 hex	PLC Function Processing Error	Errors Related to Controller Operation	W500, W501, W578
44430000 hex	PLC System Information	Errors Related to Controller Operation	W500, W501, W535, W578
44440000 hex	NX Bus Function Processing Error	NX Bus	W501, W578
44450000 hex	NX Bus System Information	NX Bus	W501, W578
47800000 hex	CNC Initialization Error	CNC Function	O030
47810000 hex	CNC Parameter Setting Invalid	CNC Function	O030
48020000 hex	System Error	FH/FZ5 Series Vision System	Z342
48080000 hex	FPGA WDT Error	Servo 1S	I586
50010000 hex	Controller Insufficient Memory Warning	Built-in EtherCAT Master in CPU Unit and Built-in EtherNet/IP Port on CPU Unit	W505, W506
54010400 hex	Input Value Out of Range	Instructions	W502
54010401 hex	Input Mismatch	Instructions	W502
54010402 hex	Floating-point Error	Instructions	W502
54010403 hex	BCD Error	Instructions	W502
54010404 hex	Signed BCD Error	Instructions	W502
54010405 hex	Illegal Bit Position Specified	Instructions	W502
54010406 hex	Illegal Data Position Specified	Instructions	W502
54010407 hex	Data Range Exceeded	Instructions	W502
54010409 hex	No Errors to Clear	Instructions	W502
5401040B hex	No User Errors to Clear	Instructions	W502
5401040C hex	Limit Exceeded for User-defined Error	Instructions	W502
5401040D hex	Illegal Unit Specified	Instructions	W502
5401040F hex	Unit Restart Failed	Instructions	W502
54010410 hex	Text String Format Error	Instructions	W502
54010411 hex	Illegal Program Specified	Instructions	W502
54010413 hex	Undefined CJ-series Memory Address	Instructions	W502
54010414 hex	Stack Underflow	Instructions	W502
54010416 hex	Illegal Number of Array Elements or Dimensions	Instructions	W502
54010417 hex	Specified Task Does Not Exist	Instructions	W502
54010418 hex	Unallowed Task Specification	Instructions	W502
54010419 hex	Incorrect Data Type	Instructions	W502
5401041A hex	Multi-execution of Instructions	Instructions	W502
5401041B hex	Data Capacity Exceeded	Instructions	W502
5401041C hex	Different Data Sizes	Instructions	W502

Event code	Event name	Functional classification	Reference
5401041D hex	Exceeded Simultaneous Instruction Executed Resources	Instructions	W502
54010800 hex	FINS Error	Instructions	W502
54010801 hex	FINS Port Already in Use	Instructions	W502
54010C00 hex	Illegal Serial Communications Mode	Instructions	W502
54010C02 hex	Port Setup Already Busy	Instructions	W502
54010C03 hex	Full Reception Buffer	Instructions	W502
54010C04 hex	Multi-execution of Ports	Instructions	W502
54010C05 hex	Parity Error	Instructions	W502
54010C06 hex	Framing Error	Instructions	W502
54010C07 hex	Overrun Error	Instructions	W502
54010C08 hex	CRC Mismatch	Instructions	W502
54010C0B hex	Serial Communications Timeout	Instructions	W502
54010C0C hex	Instruction Executed to Inapplicable Port	Instructions	W502
54010C0D hex	CIF Unit Initialized	Instructions	W502
54010C10 hex	Exceptional Modbus Response	Instructions	W502
54010C11 hex	Invalid Modbus Response	Instructions	W502
54011400 hex	SD Memory Card Access Failure	Instructions	W502
54011401 hex	SD Memory Card Write-protected	Instructions	W502
54011402 hex	SD Memory Card Insufficient Capacity	Instructions	W502
54011403 hex	File Does Not Exist	Instructions	W502
54011404 hex	Too Many Files/ Directories	Instructions	W502
54011405 hex	File Already in Use	Instructions	W502
54011406 hex	Open Mode Mismatch	Instructions	W502
54011407 hex	Offset Out of Range	Instructions	W502
54011408 hex	Directory Not Empty	Instructions	W502
54011409 hex	That File Name Already Exists	Instructions	W502
5401140A hex	Write Access Denied	Instructions	W502
5401140B hex	Too Many Files Open	Instructions	W502
5401140C hex	Directory Does Not Exist	Instructions	W502
5401140D hex	File or Directory Name Is Too Long	Instructions	W502
5401140E hex	SD Memory Card Access Failed	Instructions	W502
5401140F hex	Backup Operation Already in Progress	Instructions	W502
54011410 hex	Cannot Execute Backup	Instructions	W502
54011411 hex	Unit/Slave Backup Failed	Instructions	W502
54011800 hex	EtherCAT Communications Error	Instructions	W502
54011801 hex	EtherCAT Slave Does Not Respond	Instructions	W502
54011802 hex	EtherCAT Timeout	Instructions	W502
54011803 hex	Reception Buffer Overflow	Instructions	W502
54011804 hex	SDO Abort Error	Instructions	W502
54011805 hex	Saving Packet Monitor File	Instructions	W502
54011806 hex	Packet Monitoring Function Not Started	Instructions	W502
54011807 hex	Packet Monitoring Function in Operation	Instructions	W502

Event code	Event name	Functional classification	Reference
54011808 hex	Communications Resource Overflow	Instructions	W502
54011809 hex	Packet Monitoring Function Not Supported	Instructions	W502
54011C00 hex	Explicit Message Error	Instructions	W502
54011C01 hex	Incorrect Route Path	Instructions	W502
54011C02 hex	CIP Handle Out of Range	Instructions	W502
54011C03 hex	CIP Communications Resource Overflow	Instructions	W502
54011C04 hex	CIP Timeout	Instructions	W502
54011C05 hex	Class-3 Connection Not Established	Instructions	W502
54011C06 hex	CIP Communications Data Size Exceeded	Instructions	W502
54012000 hex	Local IP Address Setting Error	Instructions	W502
54012001 hex	TCP/UDP Port Already in Use	Instructions	W502
54012002 hex	Address Resolution Failed	Instructions	W502
54012003 hex	Socket Status Error	Instructions	W502
54012004 hex	Local IP Address Not Set	Instructions	W502
54012006 hex	Socket Timeout	Instructions	W502
54012007 hex	Socket Handle Out of Range	Instructions	W502
54012008 hex	Socket Communications Resource Overflow	Instructions	W502
54012400 hex	No Execution Right	Instructions	W502
54012401 hex	Settings Update Failed	Instructions	W502
54012402 hex	Too Many Simultaneous Instruction Executions	Instructions	W502
54012403 hex	FTP Client Execution Limit Exceeded	Instructions	W502
54012404 hex	File Number Limit Exceeded	Instructions	W502
54012405 hex	Directory Does Not Exist (FTP)	Instructions	W502
54012406 hex	FTP Server Connection Error	Instructions	W502
54012407 hex	Destination FTP Server Execution Failure	Instructions	W502
54012408 hex	SD Memory Card Access Failed for FTP	Instructions	W502
54012409 hex	Specified File Does Not Exist	Instructions	W502
5401240A hex	Specified File is Write Protected	Instructions	W502
5401240B hex	Failed To Delete Specified File	Instructions	W502
5401240C hex	Specified File Access Failed	Instructions	W502
5401240D hex	IP Address Setting Invalid	Instructions	W502
54012C00 hex	NX Message Error	Instructions	W502
54012C01 hex	NX Message Resource Overflow	Instructions	W502
54012C02 hex	NX Message Timeout	Instructions	W502
54012C03 hex	Incorrect NX Message Length	Instructions	W502
54012C05 hex	NX Message EtherCAT Network Error	Instructions	W502
54012C06 hex	External Restart Already Executed for Specified NX Units	Instructions	W502
54012C07 hex	Unapplicable Unit Specified for Instruction	Instructions	W502
54012C08 hex	Invalid Total Power ON Time Record	Instructions	W502
54013000 hex	DB Connection Service Not Started	DB Connection Instructions	W527

Event code	Event name	Functional classification	Reference
54013001 hex	DB Connection Service Run Mode Change Failed	DB Connection Instructions	W527
54013002 hex	DB Connection Service Shutdown or Shutting Down	DB Connection Instructions	W527
54013003 hex	Invalid DB Connection Name	DB Connection Instructions	W527
54013004 hex	DB Connection Rejected	DB Connection Instructions	W527
54013005 hex	DB Connection Failed	DB Connection Instructions	W527
54013006 hex	DB Connection Already Established	DB Connection Instructions	W527
54013007 hex	Too Many DB Connections	DB Connection Instructions	W527
54013008 hex	Invalid DB Connection	DB Connection Instructions	W527
54013009 hex	Invalid DB Map Variable	DB Connection Instructions	W527
5401300A hex	Unregistered DB Map Variable	DB Connection Instructions	W527
5401300B hex	SQL Execution Error	DB Connection Instructions	W527
5401300C hex	Spool Capacity Exceeded	DB Connection Instructions	W527
5401300E hex	Invalid Extraction Condition	DB Connection Instructions	W527
54013010 hex	Log Code Out of Range	DB Connection Instructions	W527
54013011 hex	DB Connection Disconnected Error Status	DB Connection Instructions	W527
54013012 hex	DB Connection Instruction Execution Timeout	DB Connection Instructions	W527
54013013 hex	DB Connection Service Error Stop	DB Connection Instructions	W527
54013014 hex	Data Already Spooled	DB Connection Instructions	W527
54013015 hex	DB Connection Service Initializing	DB Connection Instructions	W527
54013016 hex	DB in Process	DB Connection Instructions	W527
54013017 hex	Operation Log Disabled	DB Connection Instructions	W527
54013461 hex	Process Data Object Setting Missing	Instructions	W502
54013781 hex	Process Data Object Setting Missing	CNC Instructions	O030
54013810 hex	GEM Service Status in Initializing	GEM Instructions	W528
54013811 hex	GEM Service Status in EQStarting	GEM Instructions	W528
54013812 hex	GEM Service Status in EQInitializing	GEM Instructions	W528
54013813 hex	GEM Service Status in EQRun	GEM Instructions	W528
54013814 hex	GEM Service Status in Stop	GEM Instructions	W528
54013815 hex	GEM Service Status in Error	GEM Instructions	W528
54013816 hex	GEM Service Status in ShuttingDown	GEM Instructions	W528
54013817 hex	GEM Service Status in Shutdown	GEM Instructions	W528
54013818 hex	No Message Received	GEM Instructions	W528
54013819 hex	Multi-execution of Instructions	GEM Instructions	W528
5401381A hex	State Transition in Progress	GEM Instructions	W528
5401381B hex	Insufficient Transaction Resources	GEM Instructions	W528
54013820 hex	Too Many Characters	GEM Instructions	W528
54013821 hex	Invalid Size	GEM Instructions	W528
54013822 hex	Set to Disable	GEM Instructions	W528
54013824 hex	Undefined CEID	GEM Instructions	W528
54013825 hex	Undefined ALID	GEM Instructions	W528
54013826 hex	Undefined CCODE	GEM Instructions	W528
54013827 hex	Undefined Message Number	GEM Instructions	W528

Event code	Event name	Functional classification	Reference
54013828 hex	HSMS Communications Setting Out of Range	GEM Instructions	W528
54013829 hex	TID Out of Range	GEM Instructions	W528
5401382C hex	Undefined ECID	GEM Instructions	W528
5401382D hex	Type Mismatch	GEM Instructions	W528
5401382E hex	ECV Out of Range	GEM Instructions	W528
5401382F hex	Illegal CPNAME	GEM Instructions	W528
54013830 hex	HACK Out of Range	GEM Instructions	W528
54013831 hex	CPACK Out of Range	GEM Instructions	W528
54013832 hex	CEPACK Out of Range	GEM Instructions	W528
54013833 hex	ACKC7 Out of Range	GEM Instructions	W528
54013834 hex	ACKC7A Out of Range	GEM Instructions	W528
54013835 hex	ACKC10 Out of Range	GEM Instructions	W528
54013836 hex	EAC Out of Range	GEM Instructions	W528
54013838 hex	Illegal SECS Message	GEM Instructions	W528
54014800 hex	Device Error Received	Instructions	W502
54014801 hex	Specified Unit Does Not Exist	Instructions	W502
54014802 hex	Message Processing Limit Exceeded	Instructions	W502
54014803 hex	Specified Unit Status Error	Instructions	W502
54014804 hex	Too Many Simultaneous Instruction Executions	Instructions	W502
54014805 hex	Communications Timeout	Instructions	W502
54014806 hex	Invalid Mode	Instructions	W502
54014807 hex	I/O Power OFF Status	Instructions	W502
54014808 hex	Verification Error	Instructions	W502
54015420 hex	Electronic Gear Ratio Numerator Setting Out of Range	Instructions	W502
54015421 hex	Electronic Gear Ratio Denominator Setting Out of Range	Instructions	W502
54015422 hex	Target Velocity Setting Out of Range	Instructions and Robot Instructions	W502, W539
54015423 hex	Acceleration Setting Out of Range	Instructions and Robot Instructions	W502, W539
54015424 hex	Deceleration Setting Out of Range	Instructions and Robot Instructions	W502, W539
54015425 hex	Jerk Setting Out of Range	Instructions	W502
54015427 hex	Torque Ramp Setting Out of Range	Instructions	W502
54015428 hex	Master Coefficient Scaling Out of Range	Instructions	W502
54015429 hex	Slave Coefficient Scaling Out of Range	Instructions	W502
5401542A hex	Feeding Velocity Setting Out of Range	Instructions	W502
5401542B hex	Buffer Mode Selection Out of Range	Instructions and Robot Instructions	W502, W539
5401542C hex	Coordinate System Selection Out of Range	Instructions and Robot Instructions	W502, W539
5401542D hex	Circular Interpolation Mode Selection Out of Range	Instructions	W502
5401542E hex	Direction Selection Out of Range	Instructions and Robot Instructions	W502, W539
5401542F hex	Path Selection Out of Range	Instructions	W502
54015430 hex	Position Type Selection Out of Range	Instructions	W502
54015431 hex	Travel Mode Selection Out of Range	Instructions	W502

Event code	Event name	Functional classification	Reference
54015432 hex	Transition Mode Selection Out of Range	Instructions and Robot Instructions	W502, W539
54015433 hex	Continue Method Selection Out of Range	Instructions	W502
54015434 hex	Combine Mode Selection Out of Range	Instructions	W502
54015435 hex	Synchronization Start Condition Selection Out of Range	Instructions	W502
54015436 hex	Master and Slave Defined as Same Axis	Instructions	W502
54015437 hex	Master and Auxiliary Defined as Same Axis	Instructions	W502
54015438 hex	Master/Slave Axis Numbers Not in Ascending Order	Instructions	W502
54015439 hex	Incorrect Cam Table Specification	Instructions	W502
5401543A hex	Synchronization Stopped	Instructions	W502
5401543B hex	Motion Control Instruction Re-execution Disabled	Instructions and Robot Instructions	W502, W539
5401543C hex	Motion Control Instruction Multi-execution Disabled	Instructions and Robot Instructions	W502, W539
5401543D hex	Instruction Not Allowed for Encoder Axis Type	Instructions	W502
5401543E hex	Instruction Cannot Be Executed during Multi-axes Coordinated Control	Instructions and Robot Instructions	W502, W539
5401543F hex	Multi-axes Coordinated Control Instruction Executed for Disabled Axes Group	Instructions and Robot Instructions	W502, W539
54015440 hex	Axes Group Cannot Be Enabled	Instructions	W502
54015441 hex	Impossible Axis Operation Specified when the Servo is OFF	Instructions and Robot Instructions	W502, W539
54015442 hex	Composition Axis Stopped Error	Instructions and Robot Instructions	W502, W539
54015443 hex	Motion Control Instruction Multi-execution Buffer Limit Exceeded	Instructions and Robot Instructions	W502, W539
54015444 hex	Insufficient Travel Distance	Instructions	W502
54015445 hex	Insufficient Travel Distance to Achieve Blending Transit Velocity	Instructions	W502
54015446 hex	Move Link Constant Velocity Insufficient Travel Distance	Instructions	W502
54015447 hex	Positioning Gear Operation Insufficient Target Velocity	Instructions	W502
54015448 hex	Same Start Point and End Point for Circular Interpolation	Instructions	W502
54015449 hex	Circular Interpolation Center Specification Position Out of Range	Instructions	W502
5401544A hex	Instruction Execution Error Caused by Count Mode Setting	Instructions	W502
5401544C hex	Parameter Selection Out of Range	Instructions	W502
5401544D hex	Stop Method Selection Out of Range	Instructions	W502
5401544E hex	Latch ID Selection Out of Range for Trigger Input Condition	Instructions	W502
5401544F hex	Setting Out of Range for Writing MC Setting	Instructions	W502

Event code	Event name	Functional classification	Reference
54015450 hex	Trigger Input Condition Mode Selection Out of Range	Instructions	W502
54015451 hex	Drive Trigger Signal Selection Out of Range for Trigger Input Condition	Instructions	W502
54015453 hex	Motion Control Instruction Re-execution Disabled (Axis Specification)	Instructions	W502
54015454 hex	Motion Control Instruction Re-execution Disabled (Buffer Mode Selection)	Instructions	W502
54015455 hex	Motion Control Instruction Re-execution Disabled (Direction Selection)	Instructions	W502
54015456 hex	Motion Control Instruction Re-execution Disabled (Execution Mode)	Instructions	W502
54015457 hex	Motion Control Instruction Re-execution Disabled (Axes Group Specification)	Instructions	W502
54015458 hex	Motion Control Instruction Re-execution Disabled (Jerk Setting)	Instructions	W502
54015459 hex	Motion Control Instruction Re-execution Disabled (Master Axis)	Instructions	W502
5401545A hex	Motion Control Instruction Re-execution Disabled (MasterOffset)	Instructions	W502
5401545B hex	Motion Control Instruction Re-execution Disabled (MasterScaling)	Instructions	W502
5401545C hex	Motion Control Instruction Re-execution Disabled (MasterStartDistance)	Instructions	W502
5401545D hex	Motion Control Instruction Re-execution Disabled (Continuous)	Instructions	W502
5401545E hex	Motion Control Instruction Re-execution Disabled (MoveMode)	Instructions	W502
5401545F hex	Illegal Auxiliary Axis Specification	Instructions	W502
54015460 hex	Illegal Axis Specification	Instructions	W502
54015461 hex	Illegal Axes Group Specification	Instructions and Robot Instructions	W502, W539
54015462 hex	Illegal Master Axis Specification	Instructions	W502
54015463 hex	Motion Control Instruction Re-execution Disabled (SlaveOffset)	Instructions	W502
54015464 hex	Motion Control Instruction Re-execution Disabled (SlaveScaling)	Instructions	W502
54015465 hex	Motion Control Instruction Re-execution Disabled (StartPosition)	Instructions	W502
54015466 hex	Instruction Execution Error with Undefined Home	Instructions and Robot Instructions	W502, W539
54015467 hex	Motion Control Instruction Re-execution Disabled (Position Type)	Instructions	W502
54015468 hex	Unused Axis Specification for Master Axis	Instructions	W502
54015469 hex	First Position Setting Out of Range	Instructions	W502
5401546A hex	Last Position Setting Out of Range	Instructions	W502
5401546B hex	Illegal First/Last Position Size Relationship (Linear Mode)	Instructions	W502
5401546C hex	Master Sync Start Position Setting Out of Range	Instructions	W502
5401546D hex	Slave Sync Start Position Setting Out of Range	Instructions	W502

Event code	Event name	Functional classification	Reference
5401546E hex	Duplicate Latch ID for Trigger Input Condition	Instructions	W502
5401546F hex	Jerk Override Factor Out of Range	Instructions	W502
54015470 hex	Acceleration/Deceleration Override Factor Out of Range	Instructions	W502
54015471 hex	First Position Method Specification Out of Range	Instructions	W502
54015472 hex	Motion Control Instruction Re-execution Disabled (First Position Method)	Instructions	W502
54015474 hex	Unused Axis Specification for Auxiliary Axis	Instructions	W502
54015475 hex	Position Gear Value Error	Instructions	W502
54015476 hex	Position Gear Master Axis Zero Velocity	Instructions	W502
54015478 hex	Target Position Setting Out of Range	Instructions and Robot Instructions	W502, W539
54015479 hex	Travel Distance Out of Range	Instructions	W502
5401547A hex	Cam Table Start Point Setting Out of Range	Instructions	W502
5401547B hex	Cam Master Axis Following First Position Setting Out of Range	Instructions	W502
5401547C hex	Circular Interpolation Radius Setting Error	Instructions	W502
5401547D hex	Circular Interpolation Radius Overflow	Instructions	W502
5401547E hex	Circular Interpolation Setting Out of Range	Instructions	W502
5401547F hex	Auxiliary/Slave Axis Numbers Not in Ascending Order	Instructions	W502
54015480 hex	Cam Table Property Ascending Data Error at Update	Instructions	W502
54015481 hex	MC_Write Target Out of Range	Instructions	W502
54015482 hex	Master Travel Distance Specification Out of Range	Instructions	W502
54015483 hex	Master Distance in Acceleration Specification Out of Range	Instructions	W502
54015484 hex	Master Distance in Deceleration Specification Out of Range	Instructions	W502
54015487 hex	Execution Mode Selection Out of Range	Instructions	W502
54015488 hex	Permitted Following Error Out of Range	Instructions	W502
54015489 hex	Border Point/Center Position/Radius Specification Out of Range	Instructions	W502
5401548A hex	End Point Specification Out of Range	Instructions	W502
5401548B hex	Slave Travel Distance Specification Out of Range	Instructions	W502
5401548C hex	Phase Shift Amount Out of Range	Instructions	W502
5401548D hex	Feeding Distance Out of Range	Instructions	W502
5401548E hex	Auxiliary and Slave Defined as Same Axis	Instructions	W502
5401548F hex	Relative Position Selection Out of Range	Instructions	W502

Event code	Event name	Functional classification	Reference
54015490 hex	Cam Transition Specification Out of Range	Instructions	W502
54015491 hex	Synchronized Control End Mode Selection Out of Range	Instructions	W502
54015492 hex	Enable External Latch Instruction Execution Disabled	Instructions	W502
54015493 hex	Master Axis Offset Out of Range	Instructions	W502
54015494 hex	Slave Axis Offset Out of Range	Instructions	W502
54015495 hex	Command Current Position Count Selection Out of Range	Instructions	W502
54015496 hex	Master Axis Gear Ratio Numerator Out of Range	Instructions	W502
54015497 hex	Master Axis Gear Ratio Denominator Out of Range	Instructions	W502
54015498 hex	Auxiliary Axis Gear Ratio Numerator Out of Range	Instructions	W502
54015499 hex	Auxiliary Axis Gear Ratio Denominator Out of Range	Instructions	W502
5401549A hex	Master Axis Position Type Selection Out of Range	Instructions	W502
5401549B hex	Auxiliary Axis Position Type Selection Out of Range	Instructions	W502
5401549C hex	Target Position Ring Counter Out of Range	Instructions	W502
5401549D hex	Axes Group Composition Axis Setting Out of Range	Instructions	W502
5401549E hex	Axis Use Setting Out of Range	Instructions	W502
54015600 hex	Illegal CNC Coordinate System Specification	CNC Instructions	O030
54015601 hex	Deceleration Setting Out of Range	CNC Instructions	O030
54015602 hex	Jerk Setting Out of Range	CNC Instructions	O030
54015603 hex	CNC Instruction Re-execution Disabled	CNC Instructions	O030
54015604 hex	CNC Multi-execution Disabled	CNC Instructions	O030
54015605 hex	Unassigned Logical CNC Motor Number Specified	CNC Instructions	O030
54015606 hex	Logical CNC Motor Number Out of Range	CNC Instructions	O030
54015607 hex	Target Position Setting Out of Range	CNC Instructions	O030
54015608 hex	Impossible CNC Motor Operation Specified when the Servo is OFF	CNC Instructions	O030
54015609 hex	Target Velocity Setting Out of Range	CNC Instructions	O030
5401560A hex	Acceleration/Deceleration Setting Out of Range	CNC Instructions	O030
5401560B hex	Travel Mode Selection Out of Range	CNC Instructions	O030
5401560D hex	Parameter Selection Out of Range	CNC Instructions	O030
5401560E hex	CNC Parameter Setting Read/Write Setting Value Out of Range	CNC Instructions	O030
5401560F hex	CNC Parameter Setting Read/Write Target Out of Range	CNC Instructions	O030
54015611 hex	Homing Parameter Setting Out of Range	CNC Instructions	O030

Event code	Event name	Functional classification	Reference
54015612 hex	M Code Number Out of Range	CNC Instructions	O030
54015613 hex	CNC Instruction Re-execution Disabled (CNC Coordinate System Specification)	CNC Instructions	O030
54015614 hex	CNC Instruction Re-execution Disabled (Logical CNC Motor Number)	CNC Instructions	O030
5401561D hex	SD Memory Card Access Failure	CNC Instructions	O030
5401561E hex	File Does Not Exist	CNC Instructions	O030
5401561F hex	Illegal Load NC Program Number Specification	CNC Instructions	O030
54015620 hex	Too Many Files Open	CNC Instructions	O030
54015621 hex	File or Directory Name Is Too Long	CNC Instructions	O030
54015622 hex	SD Memory Card Access Failed	CNC Instructions	O030
54015623 hex	Load NC Program Capacity Exceeded	CNC Instructions	O030
54015624 hex	Number of NC Program Exceeded	CNC Instructions	O030
54015625 hex	Illegal CNC Motor Specification	CNC Instructions	O030
54015626 hex	Illegal CNC Motor Compensation Table Specification	CNC Instructions	O030
54015628 hex	Illegal Load NC Program	CNC Instructions	O030
54015700 hex	Homing Parameter Setting Out of Range	Instructions	W502
54015702 hex	Axis Use Change Error	Instructions	W502
54015703 hex	Cannot Change Axis Use	Instructions	W502
54015706 hex	Axes Group Mismatch with Kinematics	Robot Instructions	W539
54015707 hex	Kinematics Type Out of Range	Robot Instructions	W539
54015708 hex	Kinematics Parameter Out of Range	Robot Instructions	W539
54015709 hex	Workspace Type Out of Range	Robot Instructions	W539
5401570A hex	Workspace Parameter Out of Range	Robot Instructions	W539
5401570B hex	Invalid Coordinate System Number	Robot Instructions	W539
5401570C hex	Coordinate Transformation Parameter Out of Range	Robot Instructions	W539
5401570D hex	Transition parameters out of range	Robot Instructions	W539
54015710 hex	Kinematics Transform Not Set	Robot Instructions	W539
54015711 hex	Target Position Out of Range	Robot Instructions	W539
54015712 hex	Velocity Error Detection Value Out of Range	Robot Instructions	W539
54015713 hex	Acceleration Error Detection Value Out of Range	Robot Instructions	W539
54015714 hex	Trajectory Target Time Out of Range	Robot Instructions	W539
54015715 hex	Trajectory Type Out of Range	Robot Instructions	W539
54015716 hex	Trajectory Transition Out of Range	Robot Instructions	W539
54015717 hex	Trajectory Travel Distance Out of Range	Robot Instructions	W539
54015719 hex	Initial Workpiece Position Outside Workspace	Robot Instructions	W539
5401571A hex	Invalid Conveyor Axis Specified	Robot Instructions	W539
5401571B hex	Target Position Outside Workspace	Robot Instructions	W539
5401571C hex	Cannot Cancel Synchronization	Robot Instructions	W539

Event code	Event name	Functional classification	Reference
5401571E hex	Too Many Kinematics	Robot Instructions	W539
5401571F hex	Kinematics Initialization Error	Robot Instructions	W539
54015720 hex	Motion Control Parameter Setting Error When Changing Axis Use	Instructions	W502
54015721 hex	Required Process Data Object Not Set When Changing Axis Use	Instructions	W502
54015722 hex	Actual Position Overflow/Underflow	Instructions	W502
54015723 hex	Switch Structure Track Number Setting Out of Range	Instructions	W502
54015724 hex	Switch Structure First ON Position Setting Out of Range	Instructions	W502
54015725 hex	Switch Structure Last ON Position Setting Out of Range	Instructions	W502
54015726 hex	Switch Structure Axis Direction Out of Range	Instructions	W502
54015727 hex	Switch Structure Cam Switch Mode Out of Range	Instructions	W502
54015728 hex	Switch Structure Duration Setting Out of Range	Instructions	W502
54015729 hex	Track Option Structure ON Compensation Setting Out of Range	Instructions	W502
5401572A hex	Track Option Structure OFF Compensation Setting Out of Range	Instructions	W502
5401572B hex	Number of Array Elements in Switch Structure Variable Out of Range	Instructions	W502
5401572C hex	Number of Array Elements in Output Signal Structure Variable Out of Range	Instructions	W502
5401572D hex	Number of Array Elements in Track Option Structure Variable Out of Range	Instructions	W502
5401572E hex	Numbers of Elements in Output Signals and Track Option Arrays Not Matched	Instructions	W502
5401572F hex	Motion Control Instruction Multi-execution Disabled (Master Axis)	Instructions	W502
54015730 hex	Motion Control Instruction Multi-execution Disabled (Position Type Selection)	Instructions	W502
54015731 hex	Same Track Number Setting in Switch Structure Out of Range	Instructions	W502
54015732 hex	Invalid Tool Number	Robot Instructions	W539
54015733 hex	Tool Parameter Out of Range	Robot Instructions	W539
54015736 hex	Offset Not Allowed	Robot Instructions	W539
5401573A hex	Cannot Write Axis Parameters	Instructions	W502
5401573B hex	Axis Parameter Setting Out of Range	Instructions	W502
5401573C hex	Cam Property Setting Out of Range	Instructions	W502
5401573D hex	Cam Node Setting Out of Range	Instructions	W502
5401573E hex	Incorrect Cam Node Type Specification	Instructions	W502
5401573F hex	Insufficient Nodes in Cam Table	Instructions	W502

Event code	Event name	Functional classification	Reference
54015740 hex	Cam Node Master Axis Phase Not in Ascending Order	Instructions	W502
54015741 hex	Too Many Data Points in Cam Table	Instructions	W502
54015742 hex	Cam Table Displacement Overflow	Instructions	W502
54015743 hex	Aborted Cam Table Used	Instructions	W502
54015744 hex	Jog Mode Out of Range	Robot Instructions	W539
54015745 hex	Initial Workpiece Position Out of Range	Robot Instructions	W539
54015746 hex	Maximum Interpolation Velocity Out of Range	Robot Instructions	W539
54015747 hex	Maximum Interpolation Acceleration Out of Range	Robot Instructions	W539
54015748 hex	Maximum Interpolation Deceleration Out of Range	Robot Instructions	W539
54015749 hex	Execution ID Setting Out of Range	Instructions	W502
5401574A hex	Position Offset Out of Range	Instructions	W502
5401574B hex	PDS State Transition Command Selection Out of Range	Instructions	W502
5401574C hex	Single-axis Position Control Axis Motion Control Instruction Execution Disabled	Instructions	W502
54016440 hex	Target Position Positive Software Limit Exceeded	Instructions	W502
54016441 hex	Target Position Negative Software Limit Exceeded	Instructions	W502
54016442 hex	Command Position Overflow/Underflow	Instructions	W502
54016443 hex	Positive Limit Input	Instructions and Robot Instructions	W502, W539
54016444 hex	Negative Limit Input	Instructions and Robot Instructions	W502, W539
54016701 hex	Current Position Outside Workspace	Robot Instructions	W539
54016783 hex	Target Position Positive Software Limit Exceeded	CNC Instructions	O030
54016784 hex	Target Position Negative Software Limit Exceeded	CNC Instructions	O030
54016785 hex	Command Position Overflow/Underflow	CNC Instructions	O030
54016786 hex	Positive Limit Input	CNC Instructions	O030
54016787 hex	Negative Limit Input	CNC Instructions	O030
54017422 hex	Servo Main Circuits OFF	Instructions	W502
54017784 hex	Servo Main Circuits OFF	CNC Instructions	O030
54200000 hex	Electronic Gear Ratio Numerator Setting Out of Range	Motion Control Instructions	W508
54210000 hex	Electronic Gear Ratio Denominator Setting Out of Range	Motion Control Instructions	W508
54220000 hex	Target Velocity Setting Out of Range	Motion Control Instructions and General Robot Control	W508, W539
54230000 hex	Acceleration Setting Out of Range	Motion Control Instructions and General Robot Control	W508, W539
54240000 hex	Deceleration Setting Out of Range	Motion Control Instructions and General Robot Control	W508, W539
54250000 hex	Jerk Setting Out of Range	Motion Control Instructions	W508

Event code	Event name	Functional classification	Reference
54270000 hex	Torque Ramp Setting Out of Range	Motion Control Instructions	W508
54280000 hex	Master Coefficient Scaling Out of Range	Motion Control Instructions	W508
54290000 hex	Slave Coefficient Scaling Out of Range	Motion Control Instructions	W508
542A0000 hex	Feeding Velocity Setting Out of Range	Motion Control Instructions	W508
542B0000 hex	Buffer Mode Selection Out of Range	Motion Control Instructions and General Robot Control	W508, W539
542C0000 hex	Coordinate System Selection Out of Range	Motion Control Instructions and General Robot Control	W508, W539
542D0000 hex	Circular Interpolation Mode Selection Out of Range	Motion Control Instructions	W508
542E0000 hex	Direction Selection Out of Range	Motion Control Instructions and General Robot Control	W508, W539
542F0000 hex	Path Selection Out of Range	Motion Control Instructions	W508
54300000 hex	Position Type Selection Out of Range	Motion Control Instructions	W508
54310000 hex	Travel Mode Selection Out of Range	Motion Control Instructions	W508
54320000 hex	Transition Mode Selection Out of Range	Motion Control Instructions and General Robot Control	W508, W539
54330000 hex	Continue Method Selection Out of Range	Motion Control Instructions	W508
54340000 hex	Combine Mode Selection Out of Range	Motion Control Instructions	W508
54350000 hex	Synchronization Start Condition Selection Out of Range	Motion Control Instructions	W508
54360000 hex	Master and Slave Defined as Same Axis	Motion Control Instructions	W508
54370000 hex	Master and Auxiliary Defined as Same Axis	Motion Control Instructions	W508
54380000 hex	Master/Slave Axis Numbers Not in Ascending Order	Motion Control Instructions	W508
54390000 hex	Incorrect Cam Table Specification	Motion Control Instructions	W508
543A0000 hex	Synchronization Stopped	Motion Control Instructions	W508
543B0000 hex	Motion Control Instruction Re-execution Disabled	Motion Control Instructions and General Robot Control	W508, W539
543C0000 hex	Motion Control Instruction Multi-execution Disabled	Motion Control Instructions and General Robot Control	W508, W539
543D0000 hex	Instruction Not Allowed for Encoder Axis Type	Motion Control Instructions	W508
543E0000 hex	Instruction Cannot Be Executed during Multi-axes Coordinated Control	Motion Control Instructions and General Robot Control	W508, W539
543F0000 hex	Multi-axes Coordinated Control Instruction Executed for Disabled Axes Group	Motion Control Instructions and General Robot Control	W508, W539
54400000 hex	Axes Group Cannot Be Enabled	Motion Control Instructions	W508
54410000 hex	Impossible Axis Operation Specified when the Servo is OFF	Motion Control Instructions and General Robot Control	W508, W539
54420000 hex	Composition Axis Stopped Error	Motion Control Instructions and General Robot Control	W508, W539
54430000 hex	Motion Control Instruction Multi-execution Buffer Limit Exceeded	Motion Control Instructions and General Robot Control	W508, W539

Event code	Event name	Functional classification	Reference
54440000 hex	Insufficient Travel Distance	Motion Control Instructions	W508
54450000 hex	Insufficient Travel Distance to Achieve Blending Transit Velocity	Motion Control Instructions	W508
54460000 hex	Move Link Constant Velocity Insufficient Travel Distance	Motion Control Instructions	W508
54470000 hex	Positioning Gear Operation Insufficient Target Velocity	Motion Control Instructions	W508
54480000 hex	Same Start Point and End Point for Circular Interpolation	Motion Control Instructions	W508
54490000 hex	Circular Interpolation Center Specification Position Out of Range	Motion Control Instructions	W508
544A0000 hex	Instruction Execution Error Caused by Count Mode Setting	Motion Control Instructions	W508
544C0000 hex	Parameter Selection Out of Range	Motion Control Instructions	W508
544D0000 hex	Stop Method Selection Out of Range	Motion Control Instructions	W508
544E0000 hex	Latch ID Selection Out of Range for Trigger Input Condition	Motion Control Instructions	W508
544F0000 hex	Setting Out of Range for Writing MC Setting	Motion Control Instructions	W508
54500000 hex	Trigger Input Condition Mode Selection Out of Range	Motion Control Instructions	W508
54510000 hex	Drive Trigger Signal Selection Out of Range for Trigger Input Condition	Motion Control Instructions	W508
54530000 hex	Motion Control Instruction Re-execution Disabled (Axis Specification)	Motion Control Instructions	W508
54540000 hex	Motion Control Instruction Re-execution Disabled (Buffer Mode Selection)	Motion Control Instructions	W508
54550000 hex	Motion Control Instruction Re-execution Disabled (Direction Selection)	Motion Control Instructions	W508
54560000 hex	Motion Control Instruction Re-execution Disabled (Execution Mode)	Motion Control Instructions	W508
54570000 hex	Motion Control Instruction Re-execution Disabled (Axes Group Specification)	Motion Control Instructions and General Robot Control	W508, W539
54580000 hex	Motion Control Instruction Re-execution Disabled (Jerk Setting)	Motion Control Instructions	W508
54590000 hex	Motion Control Instruction Re-execution Disabled (Master Axis)	Motion Control Instructions	W508
545A0000 hex	Motion Control Instruction Re-execution Disabled (MasterOffset)	Motion Control Instructions	W508
545B0000 hex	Motion Control Instruction Re-execution Disabled (MasterScaling)	Motion Control Instructions	W508
545C0000 hex	Motion Control Instruction Re-execution Disabled (MasterStartDistance)	Motion Control Instructions	W508
545D0000 hex	Motion Control Instruction Re-execution Disabled (Continuous)	Motion Control Instructions	W508
545E0000 hex	Motion Control Instruction Re-execution Disabled (MoveMode)	Motion Control Instructions	W508
545F0000 hex	Illegal Auxiliary Axis Specification	Motion Control Instructions	W508
54600000 hex	Illegal Axis Specification	Motion Control Instructions	W508

Event code	Event name	Functional classification	Reference
54610000 hex	Illegal Axes Group Specification	Motion Control Instructions and General Robot Control	W508, W539
54620000 hex	Illegal Master Axis Specification	Motion Control Instructions	W508
54630000 hex	Motion Control Instruction Re-execution Disabled (SlaveOffset)	Motion Control Instructions	W508
54640000 hex	Motion Control Instruction Re-execution Disabled (SlaveScaling)	Motion Control Instructions	W508
54650000 hex	Motion Control Instruction Re-execution Disabled (StartPosition)	Motion Control Instructions	W508
54660000 hex	Instruction Execution Error with Undefined Home	Motion Control Instructions and General Robot Control	W508, W539
54670000 hex	Motion Control Instruction Re-execution Disabled (Position Type)	Motion Control Instructions	W508
54680000 hex	Unused Axis Specification for Master Axis	Motion Control Instructions	W508
54690000 hex	First Position Setting Out of Range	Motion Control Instructions	W508
546A0000 hex	Last Position Setting Out of Range	Motion Control Instructions	W508
546B0000 hex	Illegal First/Last Position Size Relationship (Linear Mode)	Motion Control Instructions	W508
546C0000 hex	Master Sync Start Position Setting Out of Range	Motion Control Instructions	W508
546D0000 hex	Slave Sync Start Position Setting Out of Range	Motion Control Instructions	W508
546E0000 hex	Duplicate Latch ID for Trigger Input Condition	Motion Control Instructions	W508
546F0000 hex	Jerk Override Factor Out of Range	Motion Control Instructions	W508
54700000 hex	Acceleration/Deceleration Override Factor Out of Range	Motion Control Instructions	W508
54710000 hex	First Position Method Specification Out of Range	Motion Control Instructions	W508
54720000 hex	Motion Control Instruction Re-execution Disabled (First Position Method)	Motion Control Instructions	W508
54740000 hex	Unused Axis Specification for Auxiliary Axis	Motion Control Instructions	W508
54750000 hex	Position Gear Value Error	Motion Control Instructions	W508
54760000 hex	Position Gear Master Axis Zero Velocity	Motion Control Instructions	W508
54770000 hex	Cam Table Data Error during Cam Motion	General Motion Control	W507
54780000 hex	Target Position Setting Out of Range	Motion Control Instructions and General Robot Control	W508, W539
54790000 hex	Travel Distance Out of Range	Motion Control Instructions	W508
547A0000 hex	Cam Table Start Point Setting Out of Range	Motion Control Instructions	W508
547B0000 hex	Cam Master Axis Following First Position Setting Out of Range	Motion Control Instructions	W508
547C0000 hex	Circular Interpolation Radius Setting Error	Motion Control Instructions	W508
547D0000 hex	Circular Interpolation Radius Overflow	Motion Control Instructions	W508
547E0000 hex	Circular Interpolation Setting Out of Range	Motion Control Instructions	W508

Event code	Event name	Functional classification	Reference
547F0000 hex	Auxiliary/Slave Axis Numbers Not in Ascending Order	Motion Control Instructions	W508
54800000 hex	Cam Table Property Ascending Data Error at Update	Motion Control Instructions	W508
54810000 hex	MC_Write Target Out of Range	Motion Control Instructions	W508
54820000 hex	Master Travel Distance Specification Out of Range	Motion Control Instructions	W508
54830000 hex	Master Distance in Acceleration Specification Out of Range	Motion Control Instructions	W508
54840000 hex	Master Distance in Deceleration Specification Out of Range	Motion Control Instructions	W508
54850000 hex	Immediate Stop Instruction Executed	General Motion Control	W507
54860000 hex	Axes Group Immediate Stop Instruction Executed	General Motion Control	W507
54870000 hex	Execution Mode Selection Out of Range	Motion Control Instructions	W508
54880000 hex	Permitted Following Error Out of Range	Motion Control Instructions	W508
54890000 hex	Border Point/Center Position/Radius Specification Out of Range	Motion Control Instructions	W508
548A0000 hex	End Point Specification Out of Range	Motion Control Instructions	W508
548B0000 hex	Slave Travel Distance Specification Out of Range	Motion Control Instructions	W508
548C0000 hex	Phase Shift Amount Out of Range	Motion Control Instructions	W508
548D0000 hex	Feeding Distance Out of Range	Motion Control Instructions	W508
548E0000 hex	Auxiliary and Slave Defined as Same Axis	Motion Control Instructions	W508
548F0000 hex	Relative Position Selection Out of Range	Motion Control Instructions	W508
54900000 hex	Cam Transition Specification Out of Range	Motion Control Instructions	W508
54910000 hex	Synchronized Control End Mode Selection Out of Range	Motion Control Instructions	W508
54920000 hex	Enable External Latch Instruction Execution Disabled	Motion Control Instructions	W508
54930000 hex	Master Axis Offset Out of Range	Motion Control Instructions	W508
54940000 hex	Slave Axis Offset Out of Range	Motion Control Instructions	W508
54950000 hex	Command Current Position Count Selection Out of Range	Motion Control Instructions	W508
54960000 hex	Master Axis Gear Ratio Numerator Out of Range	Motion Control Instructions	W508
54970000 hex	Master Axis Gear Ratio Denominator Out of Range	Motion Control Instructions	W508
54980000 hex	Auxiliary Axis Gear Ratio Numerator Out of Range	Motion Control Instructions	W508
54990000 hex	Auxiliary Axis Gear Ratio Denominator Out of Range	Motion Control Instructions	W508
549A0000 hex	Master Axis Position Type Selection Out of Range	Motion Control Instructions	W508
549B0000 hex	Auxiliary Axis Position Type Selection Out of Range	Motion Control Instructions	W508

Event code	Event name	Functional classification	Reference
549C0000 hex	Target Position Ring Counter Out of Range	Motion Control Instructions	W508
549D0000 hex	Axes Group Composition Axis Setting Out of Range	Motion Control Instructions	W508
549E0000 hex	Axis Use Setting Out of Range	Motion Control Instructions	W508
54A00000 hex	Results Information, ID Tag Address Error	CJ-series ID Sensor Units	Z317
54A10000 hex	Results Information, Write Protection Error	CJ-series ID Sensor Units	Z317
54A20000 hex	Results Information, Command Error	CJ-series ID Sensor Units	Z317
54A80000 hex	Command Error	CJ-series Serial Communications Units	W494
54A90000 hex	Sequence Abort Completed	CJ-series Serial Communications Units	W494
54AA0000 hex	Protocol Macro Error	CJ-series Serial Communications Units	W494
54AE0000 hex	Multiple Switches ON Error	CJ-series EtherNet/IP Units	W495
54AF0000 hex	Access Detected Outside Range of Variable	CJ-series EtherNet/IP Units	W495
54E00000 hex	Access Detected Outside Range of Variable	Built-in EtherNet/IP Port on CPU Unit	W506
55000000 hex	Division by Zero	NX-series Safety Control Unit	Z930
55010000 hex	Cast Error	NX-series Safety Control Unit	Z930
55020000 hex	MUX Error	NX-series Safety Control Unit	Z930
56000000 hex	Illegal CNC Coordinate System Specification	CNC Function	O030
56010000 hex	Deceleration Setting Out of Range	CNC Function	O030
56020000 hex	Jerk Setting Out of Range	CNC Function	O030
56030000 hex	CNC Instruction Re-execution Disabled	CNC Function	O030
56040000 hex	CNC Multi-execution Disabled	CNC Function	O030
56050000 hex	Unassigned Logical CNC Motor Number Specified	CNC Function	O030
56060000 hex	Logical CNC Motor Number Out of Range	CNC Function	O030
56070000 hex	Target Position Setting Out of Range	CNC Function	O030
56080000 hex	Impossible CNC Motor Operation Specified when the Servo is OFF	CNC Function	O030
56090000 hex	Target Velocity Setting Out of Range	CNC Function	O030
560A0000 hex	Acceleration/Deceleration Setting Out of Range	CNC Function	O030
560B0000 hex	Travel Mode Selection Out of Range	CNC Function	O030
560C0000 hex	Immediate Stop Instruction Executed	CNC Function	O030
560D0000 hex	Parameter Selection Out of Range	CNC Function	O030
560E0000 hex	CNC Parameter Setting Read/Write Setting Value Out of Range	CNC Function	O030
560F0000 hex	CNC Parameter Setting Read/Write Target Out of Range	CNC Function	O030
56100000 hex	Cycle Start Error with Undefined Home	CNC Function	O030

Event code	Event name	Functional classification	Reference
56110000 hex	Homing Parameter Setting Out of Range	CNC Function	O030
56120000 hex	M Code Number Out of Range	CNC Function	O030
56130000 hex	CNC Instruction Re-execution Disabled (CNC Coordinate System Specification)	CNC Function	O030
56140000 hex	CNC Instruction Re-execution Disabled (Logical CNC Motor Number)	CNC Function	O030
56150000 hex	Illegal NC Program	CNC Function	O030
56160000 hex	Cycle Start Multi-execution Disabled	CNC Function	O030
56170000 hex	Impossible CNC Motor Cycle Start Specified when the Servo is OFF	CNC Function	O030
56180000 hex	Illegal NC Program Number Specification	CNC Function	O030
56190000 hex	Illegal Back Trace Specification	CNC Function	O030
561D0000 hex	SD Memory Card Access Failure	CNC Function	O030
561E0000 hex	File Does Not Exist	CNC Function	O030
561F0000 hex	Illegal Load NC Program Number Specification	CNC Function	O030
56200000 hex	Too Many Files Open	CNC Function	O030
56210000 hex	File or Directory Name Is Too Long	CNC Function	O030
56220000 hex	SD Memory Card Access Failed	CNC Function	O030
56230000 hex	Load NC Program Capacity Exceeded	CNC Function	O030
56240000 hex	Number of NC Program Exceeded	CNC Function	O030
56250000 hex	Illegal CNC Motor Specification	CNC Function	O030
56260000 hex	Illegal CNC Motor Compensation Table Specification	CNC Function	O030
56280000 hex	Illegal Load NC Program	CNC Function	O030
56290000 hex	NC Program Capacity Exceeded	CNC Function	O030
57000000 hex	Homing Parameter Setting Out of Range	Motion Control Instructions	W508
57020000 hex	Axis Use Change Error	Motion Control Instructions	W508
57030000 hex	Cannot Change Axis Use	Motion Control Instructions	W508
57050000 hex	Kinematics Unsupported Instruction	General Robot Control	W539
57060000 hex	Axes Group Mismatch with Kinematics	General Robot Control	W539
57070000 hex	Kinematics Type Out of Range	General Robot Control	W539
57080000 hex	Kinematics Parameter Out of Range	General Robot Control	W539
57090000 hex	Workspace Type Out of Range	General Robot Control	W539
570A0000 hex	Workspace Parameter Out of Range	General Robot Control	W539
570B0000 hex	Invalid Coordinate System Number	General Robot Control	W539
570C0000 hex	Coordinate Transformation Parameter Out of Range	General Robot Control	W539
570D0000 hex	Transition parameters out of range	General Robot Control	W539
570F0000 hex	Cannot Calculate Kinematics	General Robot Control	W539
57100000 hex	Kinematics Transform Not Set	General Robot Control	W539
57110000 hex	Target Position Out of Range	General Robot Control	W539
57120000 hex	Velocity Error Detection Value Out of Range	General Robot Control	W539

Event code	Event name	Functional classification	Reference
57130000 hex	Acceleration Error Detection Value Out of Range	General Robot Control	W539
57140000 hex	Trajectory Target Time Out of Range	General Robot Control	W539
57150000 hex	Trajectory Type Out of Range	General Robot Control	W539
57160000 hex	Trajectory Transition Out of Range	General Robot Control	W539
57170000 hex	Trajectory Travel Distance Out of Range	General Robot Control	W539
57190000 hex	Initial Workpiece Position Outside Workspace	General Robot Control	W539
571A0000 hex	Invalid Conveyor Axis Specified	General Robot Control	W539
571B0000 hex	Target Position Outside Workspace	General Robot Control	W539
571C0000 hex	Cannot Cancel Synchronization	General Robot Control	W539
571D0000 hex	Too Many Reset Motion Control Error Instructions	General Motion Control	W507
571E0000 hex	Too Many Kinematics	General Robot Control	W539
571F0000 hex	Kinematics Initialization Error	General Robot Control	W539
57200000 hex	Motion Control Parameter Setting Error When Changing Axis Use	Motion Control Instructions	W508
57210000 hex	Required Process Data Object Not Set When Changing Axis Use	Motion Control Instructions	W508
57220000 hex	Actual Position Overflow/Underflow	Motion Control Instructions	W508
57230000 hex	Switch Structure Track Number Setting Out of Range	Motion Control Instructions	W508
57240000 hex	Switch Structure First ON Position Setting Out of Range	Motion Control Instructions	W508
57250000 hex	Switch Structure Last ON Position Setting Out of Range	Motion Control Instructions	W508
57260000 hex	Switch Structure Axis Direction Out of Range	Motion Control Instructions	W508
57270000 hex	Switch Structure Cam Switch Mode Out of Range	Motion Control Instructions	W508
57280000 hex	Switch Structure Duration Setting Out of Range	Motion Control Instructions	W508
57290000 hex	Track Option Structure ON Compensation Setting Out of Range	Motion Control Instructions	W508
572A0000 hex	Track Option Structure OFF Compensation Setting Out of Range	Motion Control Instructions	W508
572B0000 hex	Number of Array Elements in Switch Structure Variable Out of Range	Motion Control Instructions	W508
572C0000 hex	Number of Array Elements in Output Signal Structure Variable Out of Range	Motion Control Instructions	W508
572D0000 hex	Number of Array Elements in Track Option Structure Variable Out of Range	Motion Control Instructions	W508
572E0000 hex	Numbers of Elements in Output Signals and Track Option Arrays Not Matched	Motion Control Instructions	W508
572F0000 hex	Motion Control Instruction Multi-execution Disabled (Master Axis)	Motion Control Instructions	W508
57300000 hex	Motion Control Instruction Multi-execution Disabled (Position Type Selection)	Motion Control Instructions	W508

Event code	Event name	Functional classification	Reference
57310000 hex	Same Track Number Setting in Switch Structure Out of Range	Motion Control Instructions	W508
57320000 hex	Invalid Tool Number	General Robot Control	W539
57330000 hex	Tool Parameter Out of Range	General Robot Control	W539
57340000 hex	Unsupported Transition Data	General Robot Control	W539
57360000 hex	Offset Not Allowed	General Robot Control	W539
57370000 hex	Motion Control Instruction Multi-execution Disabled (Trajectory Type)	General Robot Control	W539
57390000 hex	Unsupported Transition Mode	General Robot Control	W539
573A0000 hex	Cannot Write Axis Parameters	Motion Control Instructions	W508
573B0000 hex	Axis Parameter Setting Out of Range	Motion Control Instructions	W508
573C0000 hex	Cam Property Setting Out of Range	Motion Control Instructions	W508
573D0000 hex	Cam Node Setting Out of Range	Motion Control Instructions	W508
573E0000 hex	Incorrect Cam Node Type Specification	Motion Control Instructions	W508
573F0000 hex	Insufficient Nodes in Cam Table	Motion Control Instructions	W508
57400000 hex	Cam Node Master Axis Phase Not in Ascending Order	Motion Control Instructions	W508
57410000 hex	Too Many Data Points in Cam Table	Motion Control Instructions	W508
57420000 hex	Cam Table Displacement Overflow	Motion Control Instructions	W508
57430000 hex	Aborted Cam Table Used	Motion Control Instructions	W508
57440000 hex	Jog Mode Out of Range	General Robot Control	W539
57450000 hex	Initial Workpiece Position Out of Range	General Robot Control	W539
57460000 hex	Maximum Interpolation Velocity Out of Range	General Robot Control	W539
57470000 hex	Maximum Interpolation Acceleration Out of Range	General Robot Control	W539
57480000 hex	Maximum Interpolation Deceleration Out of Range	General Robot Control	W539
57490000 hex	Execution ID Setting Out of Range	Motion Control Instructions	W508
574A0000 hex	Position Offset Out of Range	Motion Control Instructions	W508
574B0000 hex	PDS State Transition Command Selection Out of Range	Motion Control Instructions	W508
574C0000 hex	Single-axis Position Control Axis Motion Control Instruction Execution Disabled	Motion Control Instructions	W508
58210000 hex	Output Control Timeout for Parallel I/O, PLC Link, or EtherNet/IP	FH/FZ5 Series Vision System	Z342
58220000 hex	Output Control Timeout for EtherCAT	FH/FZ5 Series Vision System	Z342
58230000 hex	Initial scene group error	FH/FZ5 Series Vision System	Z342
58240000 hex	Initial scene number error	FH/FZ5 Series Vision System	Z342
60010000 hex	Task Period Exceeded	Errors Related to Tasks	W501
60020000 hex	Task Execution Timeout	Errors Related to Tasks	W501
60030000 hex	I/O Refreshing Timeout Error	Errors Related to Tasks	W501
60040000 hex	Insufficient System Service Time Error	Errors Related to Tasks	W501
60050000 hex	Task Period Exceeded	Errors Related to Tasks	W501
64010000 hex	Impossible to Access Special Unit	Errors Related to CJ-series Unit Configuration	W500

Event code	Event name	Functional classification	Reference
64200000 hex	Emergency Message Detected	Built-in EtherCAT Master in CPU Unit	W505
64400000 hex	Target Position Positive Software Limit Exceeded	Motion Control Instructions	W508
64410000 hex	Target Position Negative Software Limit Exceeded	Motion Control Instructions	W508
64420000 hex	Command Position Overflow/Underflow	Motion Control Instructions	W508
64430000 hex	Positive Limit Input	Motion Control Instructions and General Robot Control	W508, W539
64440000 hex	Negative Limit Input	Motion Control Instructions and General Robot Control	W508, W539
64450000 hex	Positive Software Limit Exceeded	General Motion Control	W507
64460000 hex	Negative Software Limit Exceeded	General Motion Control	W507
64470000 hex	In-position Check Time Exceeded	General Motion Control	W507
64480000 hex	Following Error Limit Exceeded	General Motion Control	W507
64490000 hex	Immediate Stop Input	General Motion Control	W507
644A0000 hex	Positive Limit Input Detected	General Motion Control	W507
644B0000 hex	Negative Limit Input Detected	General Motion Control	W507
644C0000 hex	Following Error Warning	General Motion Control	W507
644D0000 hex	Velocity Warning	General Motion Control	W507
644E0000 hex	Acceleration Warning	General Motion Control	W507
644F0000 hex	Deceleration Warning	General Motion Control	W507
64500000 hex	Positive Torque Warning	General Motion Control	W507
64510000 hex	Negative Torque Warning	General Motion Control	W507
64520000 hex	Command Position Overflow	General Motion Control	W507
64530000 hex	Command Position Underflow	General Motion Control	W507
64540000 hex	Actual Position Overflow	General Motion Control	W507
64550000 hex	Actual Position Underflow	General Motion Control	W507
64560000 hex	Illegal Following Error	General Motion Control	W507
64570000 hex	Servo OFF Error	General Motion Control	W507
64580000 hex	Absolute Encoder Current Position Calculation Failed	General Motion Control	W507
64590000 hex	Home Undefined during Coordinated Motion	General Motion Control and General Robot Control	W507, W539
645A0000 hex	Maximum Interpolation Velocity Error	General Robot Control	W539
645B0000 hex	Maximum Interpolation Acceleration Error	General Robot Control	W539
645C0000 hex	Maximum Interpolation Deceleration Error	General Robot Control	W539
64780000 hex	Input Disconnection Detected	CJ-series Analog I/O Units	W490
64790000 hex	Output Set Value Error	CJ-series Analog I/O Units	W490
647A0000 hex	Input Error	CJ-series Process I/O Units	W498
647D0000 hex	Zero/Span Adjustment Period End	CJ-series Process I/O Units	W498
647E0000 hex	Zero/Span Adjustment Period Notice	CJ-series Process I/O Units	W498
64840000 hex	Sensor Error	CJ-series Temperature Control Units	W491
64850000 hex	CT Overflow	CJ-series Temperature Control Units	W491
64860000 hex	Heater Burnout Alarm	CJ-series Temperature Control Units	W491
648C0000 hex	Unit Status, Command Error End	CJ-series ID Sensor Units	Z317
648D0000 hex	Results Information, Verification Error	CJ-series ID Sensor Units	Z317

Event code	Event name	Functional classification	Reference
648E0000 hex	Results Information, ID Tag Communications Error	CJ-series ID Sensor Units	Z317
648F0000 hex	Results Information, ID Tag Missing Error	CJ-series ID Sensor Units	Z317
64900000 hex	Results Information, ID System Error 1	CJ-series ID Sensor Units	Z317
64910000 hex	Results Information, ID System Error 2	CJ-series ID Sensor Units	Z317
64920000 hex	Results Information, ID System Error 3	CJ-series ID Sensor Units	Z317
64930000 hex	Results Information, ID Tag Status	CJ-series ID Sensor Units	Z317
64940000 hex	Results Information, Error Correction	CJ-series ID Sensor Units	Z317
64980000 hex	Representative Warning	CJ-series CompoNet Master Unit	W493
64990000 hex	Representative Alarm	CJ-series CompoNet Master Unit	W493
64A00000 hex	Tfs (Send Finished Monitoring Time) Exceeded	CJ-series Serial Communications Units	W494
64A10000 hex	Tfr (Receive Finished Monitoring Time) Exceeded	CJ-series Serial Communications Units	W494
64A20000 hex	Tr (Receive Wait Monitoring Time) Exceeded	CJ-series Serial Communications Units	W494
64A30000 hex	FCS Check Error	CJ-series Serial Communications Units	W494
64A40000 hex	Timeout Error	CJ-series Serial Communications Units	W494
64A50000 hex	Comparison Error	CJ-series Serial Communications Units	W494
64A60000 hex	Reception Overflow	CJ-series Serial Communications Units	W494
64A70000 hex	Command Format Error	CJ-series Serial Communications Units	W494
64AC0000 hex	Send Timeout Error	CJ-series DeviceNet Units	W497
64CC0000 hex	I/O Disconnection Detected	GX-series EtherCAT Slave Units	W488
64E00000 hex	Drive Prohibition Input Error 1	Servo G5 and G5 Linear	I576, I577
64E10000 hex	Drive Prohibition Input Error 2	Servo G5 and G5 Linear	I576, I577
64E20000 hex	Immediate Stop Input Error	Servo G5 and G5 Linear	I576, I577
64E30000 hex	Drive Prohibition Input Error	Servo 1S	I586
64F00000 hex	Unit Over Range for Channel 1	NX-series Analog I/O Units	W522
64F10000 hex	Unit Over Range for Channel 2	NX-series Analog I/O Units	W522
64F20000 hex	Unit Over Range for Channel 3	NX-series Analog I/O Units	W522
64F30000 hex	Unit Over Range for Channel 4	NX-series Analog I/O Units	W522
64F40000 hex	Unit Over Range for Channel 5	NX-series Analog I/O Units	W522
64F50000 hex	Unit Over Range for Channel 6	NX-series Analog I/O Units	W522
64F60000 hex	Unit Over Range for Channel 7	NX-series Analog I/O Units	W522
64F70000 hex	Unit Over Range for Channel 8	NX-series Analog I/O Units	W522

Event code	Event name	Functional classification	Reference
64F80000 hex	Unit Under Range for Channel 1	NX-series Analog I/O Units	W522
64F90000 hex	Unit Under Range for Channel 2	NX-series Analog I/O Units	W522
64FA0000 hex	Unit Under Range for Channel 3	NX-series Analog I/O Units	W522
64FB0000 hex	Unit Under Range for Channel 4	NX-series Analog I/O Units	W522
64FC0000 hex	Unit Under Range for Channel 5	NX-series Analog I/O Units	W522
64FD0000 hex	Unit Under Range for Channel 6	NX-series Analog I/O Units	W522
64FE0000 hex	Unit Under Range for Channel 7	NX-series Analog I/O Units	W522
64FF0000 hex	Unit Under Range for Channel 8	NX-series Analog I/O Units	W522
65030000 hex	Unit I/O Disconnection Detected for Channel 1	NX-series Analog I/O Units	W522
65040000 hex	Unit I/O Disconnection Detected for Channel 2	NX-series Analog I/O Units	W522
65050000 hex	Unit I/O Disconnection Detected for Channel 3	NX-series Analog I/O Units	W522
65060000 hex	Unit I/O Disconnection Detected for Channel 4	NX-series Analog I/O Units	W522
65070000 hex	Unit I/O Disconnection Detected for Channel 5	NX-series Analog I/O Units	W522
65080000 hex	Unit I/O Disconnection Detected for Channel 6	NX-series Analog I/O Units	W522
65090000 hex	Unit I/O Disconnection Detected for Channel 7	NX-series Analog I/O Units	W522
650A0000 hex	Unit I/O Disconnection Detected for Channel 8	NX-series Analog I/O Units	W522
65100000 hex	Sensor Disconnected Error	NX-series Analog I/O Units	W566
65110000 hex	Process Value Over Range	NX-series Analog I/O Units	W566
65120000 hex	Process Value Under Range	NX-series Analog I/O Units	W566
65130000 hex	Sensor Disconnected Error	NX-series Load Cell Input Units	W565
65140000 hex	Over Range	NX-series Load Cell Input Units	W565
65150000 hex	Under Range	NX-series Load Cell Input Units	W565
65200000 hex	I/O Power Supply Voltage Error	NX-series Safety Control Unit	Z930
65210000 hex	Output Power Interrupt Circuit Error	NX-series Safety Control Unit	Z930
65220000 hex	External Test Signal Failure at Safety Input	NX-series Safety Control Unit	Z930
65230000 hex	Discrepancy Error at Safety Input	NX-series Safety Control Unit	Z930
65240000 hex	Overload Detected at Test Output	NX-series Safety Control Unit	Z930
65250000 hex	Stuck-at-high Detected at Test Output	NX-series Safety Control Unit	Z930
65270000 hex	Short Circuit Detected at Safety Output	NX-series Safety Control Unit	Z930
65280000 hex	Stuck-at-high Detected at Safety Output	NX-series Safety Control Unit	Z930
652C0000 hex	Heater Burnout Detected	NX-series Analog I/O Units	W566
652D0000 hex	SSR Failure Detected	NX-series Analog I/O Units	W566

Event code	Event name	Functional classification	Reference
66000000 hex	Send Transaction Queue Overrun	GEM Services	W528
66010000 hex	Reception Transaction Queue Overrun	GEM Services	W528
66020000 hex	Too Long SECS Message	GEM Services	W528
67000000 hex	Command Position Outside Workspace	General Robot Control	W539
67010000 hex	Current Position Outside Workspace	General Robot Control	W539
67020000 hex	Workpiece Synchronization Excessive Following Error	General Robot Control	W539
67030000 hex	Velocity Error Detection	General Robot Control	W539
67040000 hex	Acceleration Error Detection	General Robot Control	W539
67050000 hex	Command Current Velocity Limit Exceeded	General Robot Control	W539
67800000 hex	Immediate Stop Input	CNC Function	O030
67810000 hex	Positive Limit Input Detected	CNC Function	O030
67820000 hex	Negative Limit Input Detected	CNC Function	O030
67830000 hex	Target Position Positive Software Limit Exceeded	CNC Function	O030
67840000 hex	Target Position Negative Software Limit Exceeded	CNC Function	O030
67850000 hex	Command Position Overflow/Underflow	CNC Function	O030
67860000 hex	Positive Limit Input	CNC Function	O030
67870000 hex	Negative Limit Input	CNC Function	O030
67880000 hex	Positive Software Limit Exceeded	CNC Function	O030
67890000 hex	Negative Software Limit Exceeded	CNC Function	O030
678A0000 hex	In-position Check Time Exceeded	CNC Function	O030
678B0000 hex	Following Error Limit Exceeded	CNC Function	O030
678C0000 hex	Following Error Warning	CNC Function	O030
678D0000 hex	Command Position Overflow	CNC Function	O030
678E0000 hex	Command Position Underflow	CNC Function	O030
678F0000 hex	Actual Position Overflow	CNC Function	O030
67900000 hex	Actual Position Underflow	CNC Function	O030
67910000 hex	Illegal Following Error	CNC Function	O030
67920000 hex	Absolute Encoder Current Position Calculation Failed	CNC Function	O030
67930000 hex	Home Undefined during Coordinated Motion	CNC Function	O030
67940000 hex	Cycle Start Specified during Positive Software Limit Exceeded	CNC Function	O030
67950000 hex	Cycle Start Specified during Negative Software Limit Exceeded	CNC Function	O030
67960000 hex	Cycle Start Specified during Command Position Overflow/Underflow	CNC Function	O030
67970000 hex	Cycle Start Specified during Positive Limit Input	CNC Function	O030
67980000 hex	Cycle Start Specified during Negative Limit Input	CNC Function	O030
67990000 hex	NC Program Execution Error	CNC Function	O030

Event code	Event name	Functional classification	Reference
68010000 hex	Unit Error	CJ-series High-speed Counter Units	W492
68200000 hex	Drive Prohibition Detected	Servo 1S	I586
68210000 hex	Control Right Release Error	Servo 1S	I586
68220000 hex	Error Stop Input	Servo 1S	I586
68230000 hex	Software Limit Exceeded	Servo 1S	I586
70010000 hex	Previous Time Specified	NX-series Digital I/O Units	W521
74200000 hex	Motion Control Period Exceeded	General Motion Control	W507
74210000 hex	Servo Main Circuit Power OFF	General Motion Control	W507
74220000 hex	Servo Main Circuits OFF	Motion Control Instructions	W508
74230000 hex	Interrupt Feeding Interrupt Signal Missing	General Motion Control	W507
74240000 hex	Homing Opposite Direction Limit Input Detected	General Motion Control	W507
74250000 hex	Homing Direction Limit Input Detected	General Motion Control	W507
74260000 hex	Homing Limit Inputs Detected in Both Directions	General Motion Control	W507
74270000 hex	Home Proximity/Homing Opposite Direction Limit Input Detected	General Motion Control	W507
74280000 hex	Home Proximity/Homing Direction Limit Input Detected	General Motion Control	W507
74290000 hex	Home Input/Homing Opposite Direction Limit Input Detected	General Motion Control	W507
742A0000 hex	Home Input/Homing Direction Limit Input Detected	General Motion Control	W507
742B0000 hex	Invalid Home Input Mask Distance	General Motion Control	W507
742C0000 hex	No Home Input	General Motion Control	W507
742D0000 hex	No Home Proximity Input	General Motion Control	W507
742F0000 hex	Slave Error Detected	General Motion Control	W507
74300000 hex	Axes Group Composition Axis Error	General Motion Control and General Robot Control	W507, W539
74320000 hex	Slave Observation Detected	General Motion Control	W507
74330000 hex	MC Common Error Occurrence	General Motion Control	W507
74340000 hex	Latch Position Overflow	General Motion Control	W507
74350000 hex	Latch Position Underflow	General Motion Control	W507
74360000 hex	Master Sync Direction Error	General Motion Control	W507
74370000 hex	Slave Disconnection during Servo ON	General Motion Control	W507
74380000 hex	Feed Distance Overflow	General Motion Control	W507
74390000 hex	Error in Changing Servo Drive Control Mode	General Motion Control	W507
743A0000 hex	Master Axis Position Read Error	General Motion Control	W507
743B0000 hex	Auxiliary Axis Position Read Error	General Motion Control	W507
743C0000 hex	Cannot Execute Save Cam Table Instruction	General Motion Control	W507
743D0000 hex	Incorrect Synchronization Command	NX-series Position Interface Units	W524
743E0000 hex	Illegal Following Error	NX-series Position Interface Units	W524
743F0000 hex	Illegal State Transition	NX-series Position Interface Units	W524

Event code	Event name	Functional classification	Reference
74600000 hex	Master Function Enable/Disable Failed	CJ-series DeviceNet Units	W497
74610000 hex	Master Fixed Allocation Area Setting Failed	CJ-series DeviceNet Units	W497
74620000 hex	Scan List Register/Clear Failed	CJ-series DeviceNet Units	W497
74630000 hex	Slave Function Enable/Disable Failed	CJ-series DeviceNet Units	W497
74640000 hex	Slave Fixed Allocation Area Setting Failed	CJ-series DeviceNet Units	W497
74800000 hex	Command Warning	Servo G5 and G5 Linear	I576, I577
74810000 hex	Command Error	Servo G5 and G5 Linear	I576, I577
74900000 hex	Multiple Control Signal Input Error	ZW-CE1□T Confocal Fiber Type Displacement Sensor	Z332
74910000 hex	EXE Input Error	ZW-CE1□T Confocal Fiber Type Displacement Sensor	Z332
74920000 hex	SYNC Input Error	ZW-CE1□T Confocal Fiber Type Displacement Sensor	Z332
74930000 hex	TIMING Input Error	ZW-CE1□T Confocal Fiber Type Displacement Sensor	Z332
74940000 hex	RESET Input Error	ZW-CE1□T Confocal Fiber Type Displacement Sensor	Z332
74950000 hex	ZERO Input Error	ZW-CE1□T Confocal Fiber Type Displacement Sensor	Z332
74960000 hex	ZEROCLR Input Error	ZW-CE1□T Confocal Fiber Type Displacement Sensor	Z332
74A00000 hex	SF_Antivalent Error	NX-series Safety Control Unit	Z930
74A10000 hex	SF_EDM Error	NX-series Safety Control Unit	Z930
74A20000 hex	SF_EmergencyStop Error	NX-series Safety Control Unit	Z930
74A30000 hex	SF_EnableSwitch Error	NX-series Safety Control Unit	Z930
74A40000 hex	SF_Equivalent Error	NX-series Safety Control Unit	Z930
74A50000 hex	SF_ESPE Error	NX-series Safety Control Unit	Z930
74A60000 hex	SF_GuardLocking Error	NX-series Safety Control Unit	Z930
74A70000 hex	SF_GuardMonitoring Error	NX-series Safety Control Unit	Z930
74A80000 hex	SF_ModeSelector Error	NX-series Safety Control Unit	Z930
74A90000 hex	SF_MutingPar Error	NX-series Safety Control Unit	Z930
74AA0000 hex	SF_MutingPar_2Sensor Error	NX-series Safety Control Unit	Z930
74AB0000 hex	SF_MutingSeq Error	NX-series Safety Control Unit	Z930
74AC0000 hex	SF_OutControl Error	NX-series Safety Control Unit	Z930
74AD0000 hex	SF_SafetyRequest Error	NX-series Safety Control Unit	Z930
74AE0000 hex	SF_TestableSafetySensor Error	NX-series Safety Control Unit	Z930
74AF0000 hex	SF_TwoHandControlTypeII Error	NX-series Safety Control Unit	Z930
74B00000 hex	SF_TwoHandControlTypeIII Error	NX-series Safety Control Unit	Z930

Event code	Event name	Functional classification	Reference
77000000 hex	Conveyor Axis Position Read Error	General Robot Control	W539
77800000 hex	CNC Control Period Exceeded	CNC Function	O030
77810000 hex	CNC Planner Service Period Exceeded	CNC Function	O030
77820000 hex	CNC Coordinate System Composition CNC Motor Error	CNC Function	O030
77830000 hex	CNC Common Error Occurrence	CNC Function	O030
77840000 hex	Servo Main Circuits OFF	CNC Function	O030
77850000 hex	Servo Main Circuit Power OFF	CNC Function	O030
77860000 hex	Slave Error Detected	CNC Function	O030
77870000 hex	Slave Observation Detected	CNC Function	O030
77880000 hex	Slave Disconnection during Servo ON	CNC Function	O030
77890000 hex	Homing Opposite Direction Limit Input Detected	CNC Function	O030
778A0000 hex	Homing Direction Limit Input Detected	CNC Function	O030
778B0000 hex	Homing Limit Inputs Detected in Both Directions	CNC Function	O030
778C0000 hex	Home Proximity/Homing Opposite Direction Limit Input Detected	CNC Function	O030
778D0000 hex	Home Proximity/Homing Direction Limit Input Detected	CNC Function	O030
778E0000 hex	Home Input/Homing Opposite Direction Limit Input Detected	CNC Function	O030
778F0000 hex	Home Input/Homing Direction Limit Input Detected	CNC Function	O030
77900000 hex	Invalid Home Input Mask Distance	CNC Function	O030
77910000 hex	No Home Input	CNC Function	O030
77920000 hex	No Home Proximity Input	CNC Function	O030
78010000 hex	Operation Command Competition	Servo G5 and G5 Linear	I576, I577
78020000 hex	Absolute Encoder Status Error	Servo G5	I576
78080000 hex	TRIG Input Error	EtherCAT FQ-M-series Specialized Vision Sensors for Positioning	Z314
780A0000 hex	Scene Data Error	EtherCAT FQ-M-series Specialized Vision Sensors for Positioning	Z314
780B0000 hex	Model Error	EtherCAT FQ-M-series Specialized Vision Sensors for Positioning	Z314
780C0000 hex	Logging Error	EtherCAT FQ-M-series Specialized Vision Sensors for Positioning	Z314
780D0000 hex	Output Timeout	EtherCAT FQ-M-series Specialized Vision Sensors for Positioning	Z314
780E0000 hex	Output Size Error	EtherCAT FQ-M-series Specialized Vision Sensors for Positioning	Z314
78190000 hex	Image Logging Disk Write Error	FH/FZ5 Series Vision System	Z342
781A0000 hex	Setting Data Transfer Error	FH/FZ5 Series Vision System	Z342
781B0000 hex	Output Buffer Error (EtherCAT)	FH/FZ5 Series Vision System	Z342
78200000 hex	Pulse Output Overspeed Error	Servo 1S	I586

Event code	Event name	Functional classification	Reference
78210000 hex	Brake Interlock Error	Servo 1S	I586
78220000 hex	Command Warning	Servo 1S	I586
78230000 hex	Command Error	Servo 1S	I586
80010000 hex	Illegal Packet Discarded	Errors Related to CJ-series Unit Configuration	W500
80100000 hex	Packet Discarded	Errors Related to FINS Communications	W501
80110000 hex	Packet Discarded	Errors Related to FINS Communications	W501
80120000 hex	Packet Discarded	Errors Related to FINS Communications	W501
80200000 hex	NX Unit I/O Communications Error	NX-series Digital I/O Units, NX-series Analog I/O Units, NX-series Position Interface Units, NX-series Communications Interface Units, NX-series Safety Control Unit, NX-series Load Cell Input Units, and NX-series IO-Link Master Units	W521, W522, W566, W524, W540, Z930, W565, W570
80210000 hex	NX Unit Output Synchronization Error	NX-series Digital I/O Units, NX-series Analog I/O Units, NX-series Position Interface Units, and NX-series Load Cell Input Units	W521, W522, W524, W565
80220000 hex	NX Message Communications Error	NX-series EtherCAT Coupler Unit, NX-series Analog I/O Units, NX-series Position Interface Units, NX-series Communications Interface Units, NX-series Safety Control Unit, NX-series Load Cell Input Units, and NX-series IO-Link Master Units	W522, W566, W524, W540, Z930, W565, W570
80230000 hex	NX Message Communications Error	Errors Related to Controller Operation	W500, W501, W535, W578
80240000 hex	NX Unit Clock Not Synchronized Error	NX-series Digital I/O Units, NX-series Analog I/O Units, NX-series Position Interface Units, NX-series Communications Interface Units, NX-series Load Cell Input Units, and NX-series IO-Link Master Units	W521, W522, W566, W524, W540, W565, W570
80300000 hex	Safety Process Data Communications Timeout	NX-series Safety Control Unit	Z930
84010000 hex	IP Address Duplication Error	Built-in EtherNet/IP Port on CPU Unit	W506
84020000 hex	BOOTP Server Connection Error	Built-in EtherNet/IP Port on CPU Unit	W506
84030000 hex	DNS Server Connection Error	Built-in EtherNet/IP Port on CPU Unit	W506
84040000 hex	NTP Server Connection Error	Built-in EtherNet/IP Port on CPU Unit	W506
84050000 hex	Packet Discarded Due to Full Reception Buffer	Built-in EtherNet/IP Port on CPU Unit	W506
84060000 hex	Link OFF Detected	Built-in EtherNet/IP Port on CPU Unit	W506
84070000 hex	Tag Data Link Connection Failed	Built-in EtherNet/IP Port on CPU Unit	W506
84080000 hex	Tag Data Link Timeout	Built-in EtherNet/IP Port on CPU Unit	W506
84090000 hex	Tag Data Link Connection Timeout	Built-in EtherNet/IP Port on CPU Unit	W506
840A0000 hex	IP Address Duplication Error	Built-in EtherNet/IP Port on CPU Unit	W506
840B0000 hex	BOOTP Server Connection Error	Built-in EtherNet/IP Port on CPU Unit	W506
840C0000 hex	Tag Data Link Equipment Total Allowable Bandwidth Exceeded	Built-in EtherNet/IP Port on CPU Unit	W506
84200000 hex	Link OFF Error	Built-in EtherCAT Master in CPU Unit	W505

Event code	Event name	Functional classification	Reference
84210000 hex	Network Configuration Error	Built-in EtherCAT Master in CPU Unit	W505
84220000 hex	Network Configuration Verification Error	Built-in EtherCAT Master in CPU Unit	W505
84230000 hex	Slave Initialization Error	Built-in EtherCAT Master in CPU Unit	W505
84280000 hex	Slave Application Error	Built-in EtherCAT Master in CPU Unit	W505
84290000 hex	Process Data Transmission Error	Built-in EtherCAT Master in CPU Unit	W505
842B0000 hex	Process Data Reception Timeout	Built-in EtherCAT Master in CPU Unit	W505
842C0000 hex	Process Data Communications Error	Built-in EtherCAT Master in CPU Unit	W505
842D0000 hex	EtherCAT Message Error	Built-in EtherCAT Master in CPU Unit	W505
842E0000 hex	EtherCAT Frame Not Received	Built-in EtherCAT Master in CPU Unit	W505
842F0000 hex	Input Process Data Invalid Error	Built-in EtherCAT Master in CPU Unit	W505
84400000 hex	EtherCAT Slave Communications Error	General Motion Control	W507
84600000 hex	Communications Error	CJ-series CompoNet Master Unit	W493
84610000 hex	Repeater Unit Communications Error	CJ-series CompoNet Master Unit	W493
84680000 hex	Transmission Error	CJ-series Serial Communications Units	W494
84690000 hex	Overrun Error	CJ-series Serial Communications Units	W494
846A0000 hex	Framing Error	CJ-series Serial Communications Units	W494
846B0000 hex	Parity Error	CJ-series Serial Communications Units	W494
846C0000 hex	Overrun Error, Framing Error, or Parity Error (Transmission Error)	CJ-series Serial Communications Units	W494
846D0000 hex	Transmission Error (CRC Error)	CJ-series Serial Communications Units	W494
84740000 hex	Bus Off Detected	CJ-series DeviceNet Units	W497
84750000 hex	Remote I/O Communications Error	CJ-series DeviceNet Units	W497
84760000 hex	Remote I/O Communications Error (during Slave Operation)	CJ-series DeviceNet Units	W497
84770000 hex	Slave COS Send Failed	CJ-series DeviceNet Units	W497
84790000 hex	Error-level Device Event	GX-series EtherCAT Slave Units	W570
847A0000 hex	IO-Link Communications Error	GX-series EtherCAT Slave Units	W570
847C0000 hex	Device Configuration Verification Error	GX-series EtherCAT Slave Units	W570
84820000 hex	IO-Link Device Configuration Information Created	GX-series EtherCAT Slave Units	W570
84840000 hex	I/O Cable Short-circuit	GX-series EtherCAT Slave Units	W570
84850000 hex	I/O Power Supply ON Detected	GX-series EtherCAT Slave Units	W570
84860000 hex	Warning-level Device Event Flag	GX-series EtherCAT Slave Units	W570
84870000 hex	IO-Link Communications Module Processing Error	GX-series EtherCAT Slave Units	W570
848C0000 hex	Error-level Device Event	NX-series IO-Link Master Units	W570
848D0000 hex	IO-Link Communications Error	NX-series IO-Link Master Units	W570
848F0000 hex	Device Configuration Verification Error	NX-series IO-Link Master Units	W570
84950000 hex	IO-Link Device Configuration Information Created	NX-series IO-Link Master Units	W570

Event code	Event name	Functional classification	Reference
84970000 hex	I/O Cable Short-circuit	NX-series IO-Link Master Units	W570
84980000 hex	I/O Power Supply ON Detected	NX-series IO-Link Master Units	W570
84990000 hex	Warning-level Device Event Flag	NX-series IO-Link Master Units	W570
849A0000 hex	IO-Link Communications Module Processing Error	NX-series IO-Link Master Units	W570
84A00000 hex	Slave Unit Verification Error	GX-series EtherCAT Slave Units	W488, W570
84B00000 hex	EtherCAT Communications Warning	Servo G5, G5 Linear, and Servo 1S	I576, I577, I586
84B10000 hex	EtherCAT State Change Error	Servo G5, G5 Linear, and Servo 1S	I576, I577, I586
84B20000 hex	EtherCAT Illegal State Change Error	Servo G5, G5 Linear, and Servo 1S	I576, I577, I586
84B30000 hex	Communications Synchronization Error	Servo G5 and G5 Linear	I576, I577, I586
84B40000 hex	Synchronization Error	Servo G5, G5 Linear, and Servo 1S	I576, I577, I586
84B50000 hex	Sync Manager WDT Error	Servo G5, G5 Linear, and Servo 1S	I576, I577, I586
84B60000 hex	ESC Initialization Error	Servo G5, G5 Linear, and Servo 1S	I576, I577, I586
84B70000 hex	Slave Unit Verification Error	Servo G5, G5 Linear, and Servo 1S	I576, I577, I586
84B80000 hex	Communications Setting Error	Servo G5 and G5 Linear	I576, I577
84B90000 hex	Synchronization Interruption Error	Servo G5, G5 Linear, and Servo 1S	I576, I577, I586
84BA0000 hex	Bootstrap State Transition Request Error	Servo 1S	I586
84C00000 hex	NX Unit Communications Timeout	NX-series EtherCAT Coupler Unit	W519
84C10000 hex	NX Unit Initialization Error	NX-series EtherCAT Coupler Unit	W519
84C50000 hex	NX Unit Startup Error	NX-series EtherCAT Coupler Unit	W519
84D00000 hex	SSI Communications Error	NX-series Position Interface Units	W524
84E00000 hex	IP Address Duplication Error	CJ-series EtherNet/IP Units	W495
84E10000 hex	BOOTP Server Error	CJ-series EtherNet/IP Units	W495
84E20000 hex	Link OFF Error	CJ-series EtherNet/IP Units	W495
84F00000 hex	NX Bus I/O Communications Stopped	NX-series Safety Control Unit	Z930
84F10000 hex	NX Bus I/O Communications Stopped	NX-series Safety Control Unit	Z930
85000000 hex	Process Data WDT Error	NX-series EtherCAT Coupler Unit	W519
85010000 hex	Synchronization Interruption Error	NX-series EtherCAT Coupler Unit	W519
85020000 hex	Synchronization Error	NX-series EtherCAT Coupler Unit	W519
85030000 hex	Communications Synchronization Error	NX-series EtherCAT Coupler Unit	W519
85100000 hex	DB Connection Disconnected Error	DB Connection Service	W527
85400000 hex	Data Discarded Due to Full Internal Buffer	NX-series Communications Interface Units	W540

Event code	Event name	Functional classification	Reference
85410000 hex	Parity Error	NX-series Communications Interface Units	W540
85420000 hex	Framing Error	NX-series Communications Interface Units	W540
85430000 hex	Overrun Error	NX-series Communications Interface Units	W540
85500000 hex	NX Bus Communications Error	NX Bus	W501, W578
85510000 hex	NX Unit Communications Timeout	NX Bus	W501, W578
85520000 hex	NX Unit Initialization Error	NX Bus	W501, W578
85530000 hex	NX Unit Startup Error	NX Bus	W501, W578
85540000 hex	NX Bus I/O Communications Stopped Due to Another Event	NX Bus	W501, W578
85600000 hex	OPC UA Client Connection Rejected	OPC UA Server	W588
87800000 hex	EtherCAT Slave Communications Error	CNC Function	O030
88080000 hex	PLC Link Communications Error	FH/FZ5 Series Vision System	Z342
88100000 hex	Communications Synchronization Error	Servo 1S	I586
88120000 hex	Safety Communications Timeout	Servo 1S	I586
88130000 hex	Analog Option Board Startup Error	Built-in I/O and Option Boards	W579
88140000 hex	Analog Option Board Communications Error	Built-in I/O and Option Boards	W579
90010000 hex	Clock Changed	Errors Related to Controller Operation	W500, W501, W535, W578
90020000 hex	Time Zone Changed	Errors Related to Controller Operation	W500, W501, W535, W578
90050000 hex	User Program/Controller Configurations and Setup Downloaded	Errors Related to Controller Operation	W500, W501, W535, W578
90070000 hex	Online Edits Transferred	Errors Related to Controller Operation	W500, W501, W535, W578
90080000 hex	Variable Changed to TRUE with Forced Refreshing	Errors Related to Controller Operation	W500, W501, W535, W578
90090000 hex	Variable Changed to FALSE with Forced Refreshing	Errors Related to Controller Operation	W500, W501, W535, W578
900A0000 hex	All Forced Refreshing Cleared	Errors Related to Controller Operation	W500, W501, W535, W578
900B0000 hex	Memory All Cleared	Errors Related to Controller Operation	W500, W501, W535, W578
900C0000 hex	Event Log Cleared	Errors Related to Controller Operation	W500, W501, W535, W578
900F0000 hex	Automatic Transfer Completed	Errors Related to Controller Operation	W500, W501, W535, W578
90110000 hex	Power Turned ON	Errors Related to Controller Operation	W500, W501, W535, W578
90120000 hex	Power Interrupted	Errors Related to Controller Operation	W500, W501, W535, W578
90130000 hex	Operation Started	Errors Related to Controller Operation	W500, W501, W535, W578

Event code	Event name	Functional classification	Reference
90140000 hex	Operation Stopped	Errors Related to Controller Operation	W500, W501, W535, W578
90150000 hex	Reset Executed	Errors Related to Controller Operation	W500, W501, W535, W578
90160000 hex	User Program Execution ID Write	Errors Related to Controller Operation	W500, W501, W535, W578
90180000 hex	All Controller Errors Cleared	Errors Related to Controller Operation	W500, W501, W535, W578
90190000 hex	Forced Refreshing Cleared	Errors Related to Controller Operation	W500, W501, W535, W578
901A0000 hex	Backup Started	Errors Related to Controller Operation	W500, W501, W535, W578
901B0000 hex	Backup Completed	Errors Related to Controller Operation	W500, W501, W535, W578
901C0000 hex	Restore Operation Started	Errors Related to Controller Operation	W500, W501, W535, W578
901D0000 hex	Restore Operation Completed	Errors Related to Controller Operation	W500, W501, W535, W578
90200000 hex	SD Memory Card Program Transfer Started	Errors Related to Controller Operation	W500, W501, W535, W578
90210000 hex	SD Memory Card Program Transfer Completed	Errors Related to Controller Operation	W500, W501, W535, W578
90400000 hex	Event Log Cleared	NX-series EtherCAT Coupler Unit, NX-series Digital I/O Units, NX-series Analog I/O Units, NX-series System Units, NX-series Position Interface Units, NX-series Safety Control Unit, NX-series Load Cell Input Units, and NX-series IO-Link Master Units	W519, W521, W522, W566, W523, W524, Z930, W565, W570
90420000 hex	Restart Executed	NX-series EtherCAT Coupler Unit	W519
90430000 hex	Memory All Cleared	NX-series EtherCAT Coupler Unit and NX-series Safety Control Unit	W519, Z930
90A00000 hex	Unit Restarted	Servo 1S	I586
94010000 hex	Tag Data Link Download Started	Built-in EtherNet/IP Port on CPU Unit	W506
94020000 hex	Tag Data Link Download Finished	Built-in EtherNet/IP Port on CPU Unit	W506
94030000 hex	Tag Data Link Stopped	Built-in EtherNet/IP Port on CPU Unit	W506
94040000 hex	Tag Data Link Started	Built-in EtherNet/IP Port on CPU Unit	W506
94050000 hex	Link Detected	Built-in EtherNet/IP Port on CPU Unit	W506
94060000 hex	Restarting Ethernet Port	Built-in EtherNet/IP Port on CPU Unit	W506
94070000 hex	Tag Data Link All Run	Built-in EtherNet/IP Port on CPU Unit	W506
94080000 hex	IP Address Fixed	Built-in EtherNet/IP Port on CPU Unit	W506
94090000 hex	BOOTP Client Started	Built-in EtherNet/IP Port on CPU Unit	W506
940A0000 hex	FTP Server Started	Built-in EtherNet/IP Port on CPU Unit	W506
940B0000 hex	NTP Client Started	Built-in EtherNet/IP Port on CPU Unit	W506
940C0000 hex	SNMP Started	Built-in EtherNet/IP Port on CPU Unit	W506
94200000 hex	Notice of Insufficient Travel Distance to Achieve Blending Transit Velocity	General Motion Control	W507
94210000 hex	Error Clear from MC Test Run Tab Page	General Motion Control	W507
94220000 hex	Slave Error Code Report	General Motion Control	W507
94230000 hex	Transition Parameter Adjusted	General Robot Control	W539

Event code	Event name	Functional classification	Reference
94400000 hex	Slave Disconnected	Built-in EtherCAT Master in CPU Unit	W505
94410000 hex	Slave Connected	Built-in EtherCAT Master in CPU Unit	W505
94430000 hex	Errors Reset	Built-in EtherCAT Master in CPU Unit	W505
94440000 hex	Slave Disabled	Built-in EtherCAT Master in CPU Unit	W505
94450000 hex	Slave Enabled	Built-in EtherCAT Master in CPU Unit	W505
94500000 hex	EtherCAT Diagnosis/Statistics Log Started	Built-in EtherCAT Master in CPU Unit	W505
94510000 hex	EtherCAT Diagnosis/Statistics Log Ended	Built-in EtherCAT Master in CPU Unit	W505
94600000 hex	I/O Check Execution Started	NX-series EtherCAT Coupler Unit	W519
951E0000 hex	Sysmac Studio Communications Connection Timeout	NX-series Safety Control Unit	Z930
951F0000 hex	Clear All Memory Rejected	NX-series Safety Control Unit	Z930
95300000 hex	DB Connection Service Started	DB Connection Service	W527
95310000 hex	DB Connection Service Stopped	DB Connection Service	W527
95320000 hex	DB Connection Service Shutdown	DB Connection Service	W527
95420000 hex	GEM Service Started	GEM Services	W528
95430000 hex	Shutdown Completed	GEM Services	W528
95440000 hex	GEM Setting Data Changed	GEM Services	W528
95450000 hex	Valid SD Memory Card	GEM Services	W528
95800000 hex	NX Bus Restart Executed	NX Bus	W501, W578
95D00000 hex	OPC UA Server Started	OPC UA Server	W588
95D10000 hex	OPC UA Server Stopped	OPC UA Server	W588
95D20000 hex	Server Certificate Generated	OPC UA Server	W588
95D30000 hex	Client Certificate Discarded	OPC UA Server	W588
95D40000 hex	OPC UA Server Certificate and Security Profile Cleared	OPC UA Server	W588
97800000 hex	Slave Error Code Report	CNC Function	O030
97810000 hex	Software Limit Path Limited	CNC Function	O030
97820000 hex	CNC Function System Information	CNC Function	O030
97830000 hex	Velocity Control Command Value Saturated	CNC Function	O030
98010000 hex	Absolute Value Cleared	Servo G5	I576
98020000 hex	Position Data Initialized	Servo G5 and G5 Linear	I576, I577
98200000 hex	Absolute Value Cleared	Servo 1S	I586
98210000 hex	STO Detected	Servo 1S	I586
98220000 hex	Memory All Cleared	Servo 1S	I586
98240000 hex	Event Log Cleared	Servo 1S	I586

3-4 Instruction Error Table

For descriptions of the error codes for the instructions, refer to the descriptions of the corresponding event codes.

References for event codes that occur for each instruction are given below.

Type of instruction	Reference for event code
Basic instructions	<i>Instructions</i> on page 3-25
Motion control instructions	<i>Motion Control Instructions</i> on page 3-72
OPC UA instructions	<i>OPC UA Instructions</i> on page 3-107
DB connection instructions	<i>DB Connection Instructions</i> on page 3-110
GEM instructions	<i>GEM Instructions</i> on page 3-115
Robot instructions	<i>Robot Instructions</i> on page 3-128
CNC instructions	<i>CNC Instructions</i> on page 3-145

Refer to 1-3-1 *Types of Non-fatal Errors* for the relationship between event codes and error codes.

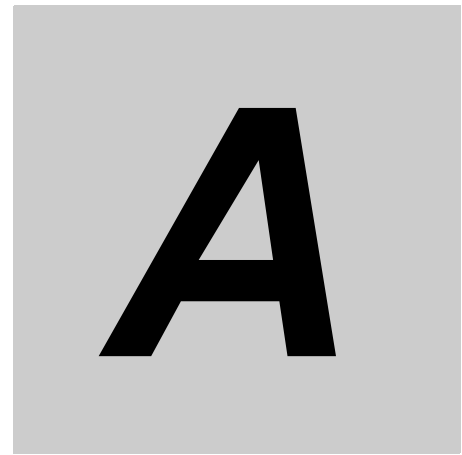

Appendix

The appendix describes the applicable range of the HMI Troubleshooter and the correspondence of NX bus events between NX1P2 CPU Units and Slave Terminals.

A

A-1	Applicable Range of the HMI Troubleshooter	A-2
A-1-1	Combinations of HMIs and CPU Units That Enable Using the Troubleshooter	A-2
A-1-2	System Configuration Elements Supported by the Troubleshooter	A-3
A-2	Correspondence of NX Bus Events between NX1P2 CPU Units and Slave Terminals	A-4

A-1 Applicable Range of the HMI Troubleshooter

Whether the HMI Troubleshooter can be used depends on the combination of the HMI and the CPU Unit. Also, the system configuration elements that are supported by the HMI Troubleshooter are different for each Troubleshooter function.

A-1-1 Combinations of HMIs and CPU Units That Enable Using the Troubleshooter

Whether the HMI Troubleshooter can be used depends on the combination of the HMI and the CPU Unit.

● NA-series HMIs

The models of HMIs on which the Troubleshooter can be used are given in the following table.

HMI	Model
NA5	NA5-□

Whether the Troubleshooter can be used for specific system versions of the above HMI models is given in the following table.

HMI system version	Connected CPU Unit	
	NX-series CPU Unit	NJ-series CPU Unit
Version 1.02 or higher	Can be used.	
Version 1.01 or lower	The HMI does not have a Troubleshooter.	

● NS-series HMIs

The models of HMIs on which the Troubleshooter can be used are given in the following table.

HMI	Model
NS8, NS10, NS12, and NS15	NS□-T□01-V2 (The V2 versions have an Ethernet port.)
NS5	NS5-□Q11-V2 (These models have expanded memory and an Ethernet port.)
NSJ8, NSJ10, and NSJ12	All models
NSJ5	NSJ5-□Q11-□ (These models have expanded memory and an Ethernet port.)

Whether the Troubleshooter can be used for specific system versions of the above HMI models is given in the following table.

HMI system version	Connected CPU Unit	
	NX-series CPU Unit	NJ-series CPU Unit
Version 8.9 or higher	Can be used.	
Version 8.5 to 8.8	Cannot be used.	Can be used.
Ver. 8.4 or lower	The HMI does not have a Troubleshooter.	

A-1-2 System Configuration Elements Supported by the Troubleshooter

The troubleshooting functions that you can use on the HMI depend on the system configuration element.

Refer to the following manuals for the NA-series HMIs and NS-series HMIs for the system configuration elements that are supported by the HMI Troubleshooter.

- NA-series Programmable Terminal Hardware User's Manual (Cat. No. V117)
- NS-series Programmable Terminals Programming Manual (Cat No. V073)



Precautions for Correct Use

On the NA-series HMI, operation related to the NX Bus Function Module is limited as follows. Use the troubleshooting function of Sysmac Studio as necessary.

- Current errors in the NX bus master are displayed, but *NX Bus Function Module* is not displayed at Source. Current errors in NX Units mounted to the CPU Unit are not displayed.
- Resetting all errors is the only way to reset current errors.
- Event logs for the NX bus master are displayed, but *NX Bus Function Module* is not displayed at Source. Event logs for NX Units mounted to the CPU Unit are not displayed.
- Event logs for the NX bus master can be deleted, but event logs for NX Units mounted to the CPU Unit cannot be deleted.



Precautions for Correct Use

On the NS-series HMI, operation related to the NX Bus Function Module is limited as follows. Use the troubleshooting function of Sysmac Studio as necessary.

- Current errors are not displayed.
- Resetting all errors is the only way to reset current errors.
- Event logs are not displayed.
- Event logs for the NX bus master can be deleted, but event logs for NX Units mounted to the CPU Unit cannot be deleted.

A-2 Correspondence of NX Bus Events between NX1P2 CPU Units and Slave Terminals

Both NX1P2 CPU Units and Slave Terminals support the mounting of NX Units. This means that NX1P2 CPU Units and Slave Terminals are subject to the same errors. However, with the NX1P2 CPU Unit, it is easier to identify the cause of an NX bus error because two or more events with more specific names may correspond to one Slave Terminal event.

The table below shows the correspondence of NX bus events, where two or more NX1P2 CPU Unit events correspond to one Slave Terminal event.

NX1P2 CPU Unit event	Slave Terminal event
NX Bus Function Processing Error (44440000 hex)	NX Unit Processing Error (40200000 hex)
NX Bus System Information (44450000 hex)	
Unsupported NX Unit Mounted* ¹	Unit Configuration Error, Unsupported Configuration (24A10000 hex)
Total I/O Data Size in NX Units Excessive (24D20000 hex)	
NX Unit Version Not Matched (35900000 hex)	Unit Configuration Verification Error (35010000 hex)
Unregistered NX Unit Mounted (35910000 hex)	
Registered NX Unit Not Mounted (35920000 hex)	
NX Unit Serial Number Mismatch (35930000 hex)	
NX Bus Communications Error (85500000 hex)	

*¹ This event will occur if the NX1P2 CPU Unit does not support any required function of NX Units that will be released in the future.



Index



Index

B

Block I/O	3-190
built-in EtherCAT master	3-99
built-in EtherNet/IP port	3-95

C

CJ1W-AD041-V1/AD081-V1	3-223
CJ1W-AD042	3-223
CJ1W-AD04U	3-225
CJ1W-CT021	3-228
CJ1W-DA021/DA041	3-223
CJ1W-DA042V	3-223
CJ1W-DA08V/DA08C	3-223
CJ1W-DRM21	3-234
CJ1W-MAD42	3-223
CJ1W-PDC15	3-225
CJ1W-PH41U	3-225
CJ1W-SCU2	3-229
CJ1W-SCU32	3-229
CJ1W-SCU42	3-229
CJ1W-TC003	3-226
CJ1W-TC004	3-226
CJ1W-TC103	3-226
CJ1W-TC104	3-226
CJ1W-V680C11	3-226
CJ1W-V680C12	3-226
CJ-series Analog I/O Units	3-223
CJ-series DeviceNet Units	3-234
CJ-series High-speed Counter Units	3-228
CJ-series ID Sensor Units	3-226
CJ-series Process I/O Units	3-225
CJ-series Serial Communications Units	3-229
CJ-series Temperature Control Units	3-226
CJ-series Units	3-223
CNC Function	3-134
CNC Instructions	3-145
Controller errors	1-12
Controller events	1-10
sources	1-11
Controller information	1-12
Controller operation	3-11
CPU Unit Reset	1-7, 2-5
CPU Unit Watchdog Timer Error	1-8, 2-6

D

DB connection instructions	3-110
DB connections service	3-104, 3-107, 3-108

E

Error Status variable	1-21, 2-16
-----------------------------	------------

errors	
checking with system-defined variables	2-16
identifying and resetting	2-7, 2-11, 2-14
resetting	2-15
EtherCAT Master Function Module	3-99
EtherCAT slaves	3-190
EtherNet/IP Function Module	3-95
event code	1-17
event log	1-9
events	1-2, 1-9, 3-64
levels	1-12

F

fatal errors	1-3
troubleshooting	2-5
FINS communications	3-22

G

G5 Series	3-192
Get NX Bus Error Status	1-21, 2-14
Get NX Unit Error Status	1-21, 2-14
GetNXBError (Get NX Bus Error Status)	1-21, 2-14
GetNXUnitError (Get NX Unit Error Status)	1-21, 2-14

H

Hardware Initialization Error	1-7, 2-6
HMI	A-2

I

Incorrect Power Supply Unit Connected	1-7, 2-6
indicators	1-4
information level	1-12
instructions	
GetCJBError	1-21, 2-14
GetECEError	1-21, 2-14
GetEIPError	1-21, 2-14
GetMCEError	1-21, 2-14
GetPLCEError	1-21, 2-14
getting error information	2-14
reading function module error status	1-21
ResetCJBError	2-15
ResetECEError	2-15
ResetMCEError	2-15
ResetPLCEError	2-15

M

major fault level	1-12
minor fault level	1-12
motion control	

general	3-64
instructions	3-72
Motion Control Function Module	3-64
MX2/RX-series Inverters	3-216

N

non-fatal errors	1-3, 1-9, 1-19
resetting	1-22
troubleshooting	2-7
NX-AD□□□□	3-157
NX-DA□□□□	3-157
NX-EC0□□□	3-168
NX-ECC□□□	3-150
NX-ECS□□□	3-168
NX-HB□□□□	3-157
NX-ID□□□□	3-154
NX-ILM400	3-187
NX-OC□□□□	3-154
NX-OD□□□□	3-154
NX-PC0□□□	3-168
NX-PD1□□□	3-168
NX-PF0□□□	3-168
NX-PG0□□□	3-168
NX-RS□□□□	3-182
NX-series Analog I/O Units	3-157
NX-series Digital I/O Units	3-154
NX-series EtherCAT Coupler Units	3-150
NX-series IO-Link Master Units	3-187
NX-series Load Cell Input Units	3-182
NX-series Position Interface Units	3-168
NX-series System Units	3-168
NX-TBX01	3-168
NX-TS□□□□	3-157

O

observation level	1-12
online	
troubleshooting problems going online	2-18

P

partial fault level	1-12
Power Supply Error	1-7, 2-5

R

Reset NX Bus Error	2-15
ResetNXBError (Reset NX Bus Error)	2-15
resetting errors	2-15
resetting non-fatal errors	1-22
robot control	3-119
robot instruction	3-128

S

self diagnosis	3-3, 3-61
source details	1-11

system-defined variables	1-21
checking for errors	2-16

T

tasks	3-10
Troubleshooter	1-20, 2-11, A-2
troubleshooting	1-20, 2-7
fatal errors	2-5
non-fatal errors	2-7

U

Unit configuration	3-7
user-defined events	1-11

OMRON Corporation Industrial Automation Company
Kyoto, JAPAN

Contact: www.ia.omron.com

Regional Headquarters

OMRON EUROPE B.V.

Wegalaan 67-69, 2132 JD Hoofddorp
The Netherlands
Tel: (31)2356-81-300/Fax: (31)2356-81-388

OMRON ELECTRONICS LLC

2895 Greenspoint Parkway, Suite 200
Hoffman Estates, IL 60169 U.S.A.
Tel: (1) 847-843-7900/Fax: (1) 847-843-7787

OMRON ASIA PACIFIC PTE. LTD.

No. 438A Alexandra Road # 05-05/08 (Lobby 2),
Alexandra Technopark,
Singapore 119967
Tel: (65) 6835-3011/Fax: (65) 6835-2711

OMRON (CHINA) CO., LTD.

Room 2211, Bank of China Tower,
200 Yin Cheng Zhong Road,
PuDong New Area, Shanghai, 200120, China
Tel: (86) 21-5037-2222/Fax: (86) 21-5037-2200

Authorized Distributor:

© OMRON Corporation 2011-2018 All Rights Reserved.
In the interest of product improvement,
specifications are subject to change without notice.

Cat. No. W503-E1-18

0118