

**Safety Liquid Leakage Sensor SQ4-A series**

MJE-SQ4A No.0077-97V

Thank you very much for purchasing Panasonic products. Please read this Instruction Manual carefully and thoroughly for the correct and optimum use of this product. Kindly keep this manual in a convenient place for quick reference. English and Japanese are original instructions.

**⚠ WARNING**

- This product is a sensor for detecting leak of fluids.
- When this product is used with safety devices, construct the system such that the device itself.

**1 ATTENTION MARKS**

This instruction manual employs the following attentions marks “ ⚠ WARNING”, and “ ⚠ CAUTION”, depending on the degree of the danger.

<b>⚠ WARNING</b>	If you ignore the advice with this mark, death or serious injury could result.
<b>⚠ CAUTION</b>	If you ignore the advice with this mark, injury or material damage could result.

**2 SAFETY PRECAUTIONS**

- Use this device as per its specifications. Do not modify this device since its functions and capabilities may not be maintained and it may malfunction.
- This device has been developed / produced for industrial use only.
- This device is suitable for indoor use only.
- Use of this device under the following conditions or environment is not presupposed.
  - 1) Operating this device under conditions and environment not described in this manual.
  - 2) Using this device in the following fields: nuclear power control, railroad, aircraft, automobiles, combustion facilities, medical systems, aerospace development, etc.
- Use this device by installing suitable protection equipment as a countermeasure for failure, damage, or malfunction of this device.
- Before using this device, check whether the device performs properly with the functions and capabilities as per the design specifications.
- In case of disposal, dispose this device as industrial waste.

**⚠ WARNING**

- ◆ **Machine designer, installer, employer and operator**
  - The machine designer, installer, employer and operator are solely responsible to ensure that all applicable legal requirements relating to the installation and the use in any application are satisfied and all instructions for installation and maintenance contained in the instruction manual are followed.
  - Whether this device functions as intended to and systems including this device comply with safety regulations depends on the appropriateness of the application, installation, maintenance and operation. The machine designer, installer, employer and operator are solely responsible for these items.
  - The engineer would be a person who is appropriately educated, has widespread knowledge and experience, and can solve various problems which may arise during work, such as a machine designer, or a person in charge of installation or operation etc.
  - The operator should read this instruction manual thoroughly, understand its contents, and perform operations following the procedures described in this manual for the correct operation of this device.
  - In case this device does not perform properly, the operator should report this to the person in charge and stop the machine operation immediately. The machine must not be operated until correct performance of this device has been confirmed.

◆ **Installation**

- There is the detection mount difference by directivity of a liquid leakage. When there are a direction from which a liquid leakage happens, and an inclination, please install the nose-of-cam side (opposite side of a cable) of a sensor towards a top.
- Use the mounting bracket **MS-SQ4-□** (optional) which suits the liquid to detect. If selecting mounting bracket is wrong, it does not work properly.
- Periodical checking of operation is recommended with the liquids which are not dangerous (water, alcohol, etc.).
- The amount of detection may change with the conditions of the installation surface.
- Be sure to use the mounting bracket **MS-SQ4-□** (optional) when installing this device to avoid human error, etc. Reliable detection cannot be guaranteed when this sensor is used alone.
- After installing this product, fix the cable at 100mm of base of this product on floor. Use the material which does not be effected by the chemical liquid for the fixing bracket for cable.

◆ **Wiring**

- In case dangerous operation of the system installed this product by no wiring to ground is not considered, it may cause serious injure or death.
- To avoid turning the power ON by no wiring to ground, wire it to ground 0V side when using PNP and wire it to ground +24V when using NPN.

◆ **Environment**

- Avoid using this device in an explosive atmosphere because this product does not have an explosive-proof protective construction.
- Do not use a mobile phone or a radio phone near this device.
- In case this device is used where electrostatic charge is present, use a metal leak pan, which should be connected to an actual ground.
- Do not install this device in the following environments.
  - 1) Areas exposed to intense interference (extraneous) light such as high-frequency fluorescent lamp (inverter type), rapid starter fluorescent lamp, stroboscopic lights, flash beacon lights or direct sunlight.
  - 2) Areas with high humidity where condensation is likely to occur
  - 3) Areas exposed to too much steam or dust. Areas exposed to corrosive or explosive gases. And do not use this device where oil or grease splashes to this device
  - 4) Areas exposed to vibration or shock of levels higher than that specified.

◆ **Maintenance**

- When using chemical liquid, use proper protections such as groves, masks, goggles, helmets etc. When using protections, me sure to read manuals of them and use properly.
- Dispose or reinstall in different environment, flush with DI water.

**3 STANDARDS / REGULATIONS**

- This product complies with following standards / regulations.

<EU Directives>

EU Machinery Directive 2006/42/EC  
EMC Directive 2014/30/EU  
RoHS Directive 2011/65/EU

<European Standards>

EN 61000-6-2, EN 55011, EN IEC 63000  
EN ISO 13849-1: 2015 (Category 1, PLc)

<International Standards>

IEC 61508-1 to 7 (SIL1), ISO 13849-1: 2015 (Category 1, PLc)  
IEC 60947-5-2 (Note)

Note: The conformity to IEC 60947-5-2 for this device has been evaluated by ourselves.

<Regulations in Korea>

S1-G-1-2009, S2-W-5-2009

- This product is pursuant to following standard.

<SEMI standard>

SEMI-S2-0310a



**4 PART DESCRIPTION**

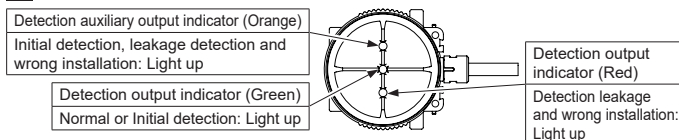

**⚠ CAUTION**

In case of installation error, detection output indicator (red) and detection auxiliary output indicator (Orange) light up

**5 MOUNTING**

**⚠ CAUTION**

Keep enough space for maintenance when mounting this product.

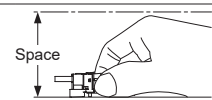

**Mounting method**

1. Mount the mounting bracket set **MS-SQ4-□** (optional) with M4 stud-bolts or adhesive.

<Mounting with M4 stud-bolts>

- 1-1 Weld the M4 stud-bolts (length: 10mm or more) to your system.

- 1-2 Insert the M4 stud-bolts (length 10mm or more) welded on the user's facilities into the mounting hole of the mounting bracket and screw with an M4 nut (purchase separately). The tightening torque should be 0.98N·m or less.

<Mounting the PVC mounting bracket with adhesive>

- 1-1 Put the adhesive to underside of the mounting bracket and stick it on surface of the system. Thickness of the adhesive after sticking is set to 0.1mm or less. And use adhesive for vinyl chloride (PVC).

Notes: 1) If the excess adhesive from the bottom surface of the exclusive mounting bracket is remained, the detection capability may be affected.

2. The attachment is set according to A part of the mounting bracket.

3. Inserts from a top by holding knob part. Then press in downward in the attachment.

Notes: 2) In case the attachment incline on the floor, malfunction can be occurred. Also, malfunction can be occurred by changing of the shape of attachment and scratch or dust etc.

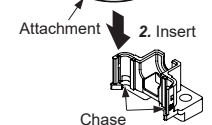
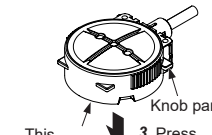
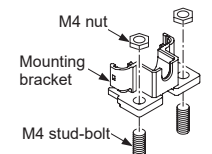

**Dismounting method**

1. Hold the knob part of this product and pull out from mounting bracket upward.

Notes: 1) When pulling out this product, it may cause break of cables. Be careful.

2) When detaching part, do not use tool etc. Malfunction can be occurred by changing of the shape of the attachment and scratch etc.

2. Pull out the attachment upward from the mounting bracket.

3. In case the mounting bracket is mounted with the M4 stud-bolts, remove M4 nuts.

In case the mounting bracket is mounted with the M4 stud-bolts, do not remove.

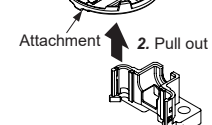
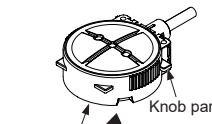

**6 I/O CIRCUIT DIAGRAMS**

- **NPN output type**

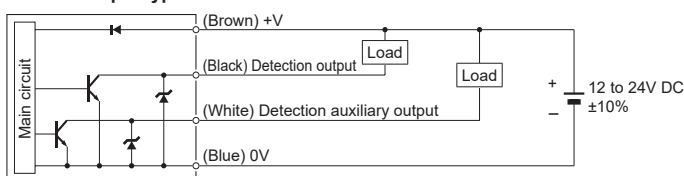

• PNP output type

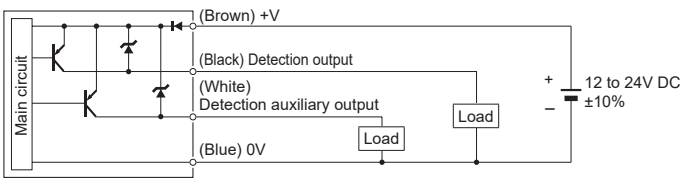

**7 HUMAN ERROR PREVENTION (SAFETY INTERLOCK) FUNCTION**

- In case this product is removed from the attachment by equipment failure after installation or maintenance (state that not detectable leakage), This product becomes interlock state and the output turns to OFF.

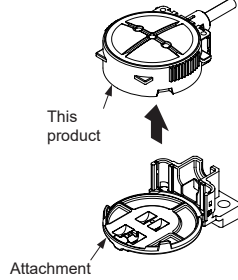

**8 MAINTENANCE**

**WARNING**

Before conduct maintenance, be sure that the system is in safety state.

• **Operation when leaked**

- When doing maintenance after leak detection, separate this device and the mounting bracket set **MS-SQ4-□** (the attachment and the mounting bracket.) For removing method, refer to "**6 MOUNTING**".

- Wipe all liquid from the attachment, sensor and the installation surface. To avoid scratching the detecting surface and the optional mounting bracket, use a soft cloth.

• **Six months inspection**

- Be sure there are no scratch, no broken, and no damage on the cable.
- Be sure there are no dust and no contamination on the detecting surface.
- Be sure the product does not float from the attachment.
- Be sure the output is correctly detected.
- Be sure safety interlock function works properly (output OFF).

• **Inspection after maintenance**

- In condition below, conduct items in six months inspection.
  - 1) After doing maintenance of this product after leakage.
  - 2) After replacing this product.
  - 3) After operation error of this product is occurred.
  - 4) After installed place of this product or installation environment is changed.
  - 5) When changed wiring or wiring method.

**9 CAUTIONS**

- Leak detection part of this product properly detects the leakage in the following condition.
  - Detection range: Area except backward of this product (liquid must enter to the detection range)
  - Material of installation surface:
    - Hard vinyl chloride or Stainless-steel
  - Surface condition for installation: glossy surface (surface roughness: corresponding 0.4µmRa) and clean surface.
  - Installation surface angle: horizontal
- This product may not detect properly liquid in following element.
  - liquid kind, consistency (surface tension) and air bubble incorporation.
  - Material, roughness, angle, dirtiness and liquid absorption of surface of installed surface of sensor.
  - Wrong selection of dedicated mounting bracket.
- Check the detecting liquid and the installation condition before use.

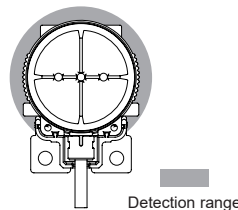

**10 OPTIONS**

Type	Model No.	Applicable Sensor	Description
Double step detection type	Standard liquid	<b>MS-SQ4-21</b>	<b>SQ4-A21-□</b> Double step detection type attachment for standard liquid: 1 pc. (Polypropylene) PVC Mounting Bracket : 1 pc.
	Chemical liquid A	<b>MS-SQ4-22</b>	<b>SQ4-A22-□</b> Double step detection type attachment for chemical liquid: 1 pc. (PFA) PFA Mounting Bracket (Stainless steel bush) : 1 pc.
	Chemical liquid B	<b>MS-SQ4-23</b>	<b>SQ4-A22-□</b> Double step detection type attachment for chemical liquid: 1 pc. (PFA) PVC Mounting Bracket : 1 pc.
	Chemical liquid C	<b>MS-SQ4-24</b>	<b>SQ4-A22-□</b> Double step detection type attachment for chemical liquid: 1 pc. (PFA) PVC Mounting Bracket : 1 pc.

Notes: 1) Chemical liquid A-- Sulfuric acid, Hydrochloric acid, Phosphoric acid or Ammonia etc. such as surface tension is stronger  
 Chemical liquid B-- Fluoriner<sup>®</sup>, Galden<sup>®</sup>, high consistency of Hydrofluoric acid etc. such as surface tension is weaker  
 Chemical liquid C Liquid such as low consistency of Hydrofluoric acid  
 Surface tension of chemical liquid is also depend on the temperature.  
 2) Further, PVC mounting bracket may not be used depending on type or viscosity etc. Before using this device, check the detecting liquid and installation condition.

Type	Model No.	Description
Controller	<b>SQ4-C11</b>	<ul style="list-style-type: none"> <li>• The controller can connect 4 sensor heads maximum.</li> <li>• In case output of sensor head is short or circuit of emitter or receiver is broken, inform you them by the indicator.</li> <li>• For more detail of the controller, refer to attached instruction manual in the controller.</li> </ul>

**11 SPECIFICATION**

Type	Standard liquid type	Chemical liquid type
Model No.	<b>SQ4-A21-N</b> <b>SQ4-A21-P</b>	<b>SQ4-A22-N</b> <b>SQ4-A22-P</b>
Detection object (Note 1)	Water (Standard liquid)	Sulfuric acid, Hydrochloric acid, Phosphoric acid, Ammonia, Fluoriner <sup>®</sup> , Galden <sup>®</sup> , Hydrofluoric acid etc. (Note 2)
Supply voltage	12 to 24V DC ±10%	Ripple P-P 10% or less
Current consumption		30mA or less
Utilization category		DC-12, DC-13
Detection output (Leakage detection)	<NPN output type> NPN open-collector transistor • Maximum sink current: 50mA • Applied voltage: Same as the supply voltage (between detection output and 0V) • Residual voltage: 2V or less (at 50mA sink current)	<PNP output type> PNP open-collector transistor • Maximum source current: 50mA • Applied voltage: Same as the supply voltage (between detection output and +V) • Residual voltage: 2.5V or less (at 50mA source current)
Response time		10ms or less
Output operation	ON when initial detection, OFF when detection leakage or wrong installation	
Short-circuit protection	Incorporated	
Detection auxiliary output (Initial detecting)	<NPN output type> NPN open-collector transistor • Maximum sink current: 50mA • Applied voltage: Same as the supply voltage (between detection auxiliary output and 0V) • Residual voltage: 2V or less (at 50mA sink current)	<PNP output type> PNP open-collector transistor • Maximum sink current: 50mA • Applied voltage: Same as the supply voltage (between detection auxiliary output and +V) • Residual voltage: 2.5V or less (at 50mA sink current)
Response time	50ms or less	
Output operation	ON when normal condition, OFF when Initial detection or accidental leakage	
Short-circuit protection	Incorporated	
Protection	IP65 / IP67 (IEC)	
Ambient temperature	-10 to +55°C (No dew condensation or icing allowed) (Note 3), Storage: -10 to +55°C	
Ambient humidity	35 to 85% RH, Storage: 35 to 85% RH	
Ambient illuminance	Incandescent light: 1,000lx at the light-receiving face	
Altitude for use	2000m or less above sea level (Note 4)	
Vibration resistance	Malfunction: 10 to 55 Hz multiple amplitude 0.75mm 2 hours for each X, Y and Z directions (in power supply)	
Shock resistance	Malfunction: Peak acceleration 294m/s <sup>2</sup> (Approx. 30G), 3 times for each X, Y and Z direction	
PFHd (Note 5)	NPN output type: 1.57 × 10 <sup>-8</sup> , NPN output type: 1.79 × 10 <sup>-8</sup>	
SFF (Note 6)	NPN output type: 94%, PNP output type: 95%	
HFT (Note 7)	0	
Sub-system time	Type A (IEC 61508-2)	
Mission time	20 years	
Detectable failure modes by connecting to SQ4-C11 (exclusive controller)	Output short, broken internal circuit and etc.	
Emitting element	Infrared LED (modulated)	
Material	Enclosure: Polypropylene	Enclosure: PFA
Cable	0.18mm <sup>2</sup> 4-core PVC cabtire cable, 2m long	0.1mm <sup>2</sup> 4-core PFA cabtire cable, 2m long
Weight	Approx. 45g	

Notes: 1) Highly viscous liquid may not be stably detected.  
 2) The agents mentioned above are examples. It may not be detected depending on viscosity the agent. Before using this device, check the detecting liquid and installation condition.  
 3) Liquid being detected should be also kept within the rated ambient temperature range.  
 4) Do not use or storage in environment of atmospheric pressure or more.  
 5) PFHd: Probability of dangerous failure per hour.  
 6) SSF: Safe failure fraction  
 7) HFT: Hardware failure tolerance

**12 CAUTIONS**

- Make sure that the power supply is OFF while wiring. Also wrong wiring cause damage of the sensor.
- If power is supplied from a commercial switching regulator, ensure that the frame ground (F.G.) terminal of the power supply is connected to an actual ground.
- Do not use during the initial transient time (approx. 50ms) after the power supply is switched ON.
- Extension up to total 30m is possible with a 0.3mm<sup>2</sup>, or more of conductor cross-section area cable. However, in order to reduce noise, make the wiring as short as possible.
- Do not run the wires together with high-voltage lines or power lines or put them in the same raceway. This can cause malfunction due to induction.
- In case a surge is generated from power supply, take countermeasures such as connecting a surge absorber to the origin of the surge.
- In case air bubbles are drawn into the detection part, take care that it may take some time for detection to stabilize, or detection may even become unstable.
- When liquid or oil remains or there is scratch on the detection surface or the attachment, It may not work properly.

**13 DIMENSIONS (unit: mm)**

• **Standard liquid type sensor SQ4-21-□**

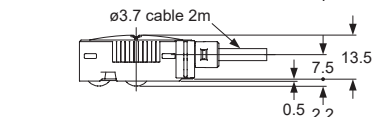
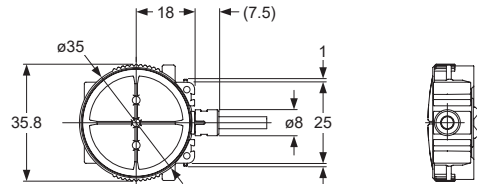

<Attached with MS-SQ4-21>

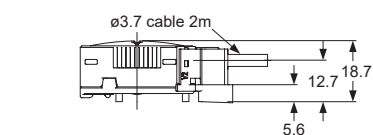
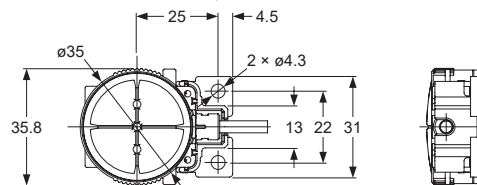

● Chemical liquid type sensor SQ4-22-□

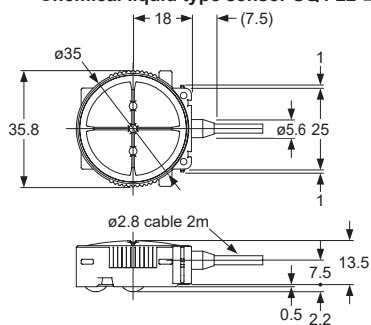

<Sensor with attachment set>

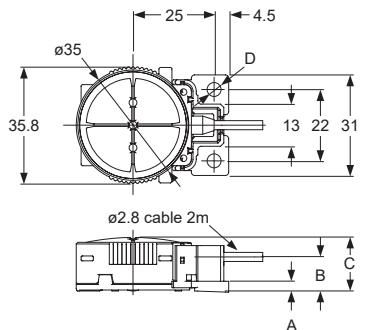

Attachment set type	A	B	C	D
MS-SQ4-22	5.4	12.7	18.7	2 × ø4.2
MS-SQ4-23	3.4	10.5	16.5	2 × ø4.3
MS-SQ4-24	5.6	12.7	18.7	2 × ø4.3

● Mounting bracket set MS-SQ4-□

<Attachment>

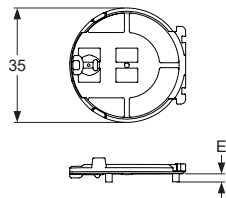

Model No.	A	E
MS-SQ4-21	5.6	2.5
MS-SQ4-22	5.4	2.5
MS-SQ4-23	3.4	0.3
MS-SQ4-24	2.5	2.5

<PVC / PFA Mounting bracket>

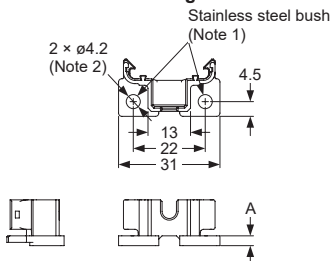

Notes: 1) Drawing above is for PFA mounting bracket. PVC mounting brackets M-SQ4-11, M-SQ4-21 and M-SQ4-23 do not incorporate stainless steel bushes.  
2) The mounting holes size of PVC mounting bracket is ø4.3.

**14 CE MARKING DECLARATION OF CONFORMITY**

**Itemized Essentials of EU Declaration of Conformity**

**Manufacturer's Name:** Panasonic Industrial Devices SUNX Co., Ltd.  
**Manufacturer's Address:** 2431-1, Ushiyama-cho, Kasugai, Aichi 486-0901, Japan

**EU Representative's Name:** Panasonic Marketing Europe GmbH Panasonic Testing Center  
**EU Representative's Address:** Winsbergring 15, 22525 Hamburg, Germany

**Product:** Safety Liquid Leakage Sensor  
**Model Name:** SQ4 Series  
**Trade Name:** Panasonic

**Application of Council Directive:**  
- 2006/42/EC Machinery Directive  
- 2014/30/EU EMC Directive  
- 2011/65/EU RoHS Directive

**Applicable Standard(s):**  
- EN ISO 13849-1: 2015  
- EN 55011  
- EN 61000-6-2  
- EN IEC 63000  
- IEC 61508-1  
- IEC 61508-2  
- IEC 61508-3  
- IEC 61508-4

**Type Examination:** Certified by TÜV SÜD Product Service GmbH  
Ridlerstrasse 65 80339 München Germany

**Panasonic Corporation**

Panasonic Industrial Devices SUNX Co., Ltd.

<https://panasonic.net/id/pidsx/global>

Please visit our website for inquiries and about our sales network.

PRINTED IN JAPAN

© Panasonic Industrial Devices SUNX Co., Ltd. 2021