

Optical Touch Switch SW-100 SERIES

Related Information

■ General terms and conditions..... F-3

■ General precautions P.1595

- FIBER SENSORS
- LASER SENSORS
- PHOTOELECTRIC SENSORS
- MICRO PHOTOELECTRIC SENSORS
- AREA SENSORS
- SAFETY LIGHT CURTAINS / SAFETY COMPONENTS
- PRESSURE / FLOW SENSORS
- INDUCTIVE PROXIMITY SENSORS
- PARTICULAR USE SENSORS
- SENSOR OPTIONS
- SIMPLE WIRE-SAVING UNITS
- WIRE-SAVING SYSTEMS
- MEASUREMENT SENSORS
- STATIC CONTROL DEVICES
- LASER MARKERS
- PLC
- HUMAN MACHINE INTERFACES
- ENERGY MANAGEMENT SOLUTIONS
- FA COMPONENTS
- MACHINE VISION SYSTEMS
- UV CURING SYSTEMS
- Selection Guide
- Safety Light Curtains
- Safety Control Units
- Safety Components
- ST4
- SW-100
- Safety Devices



panasonic.net/id/pidsx/global



Conforming to OSHA / ANSI

This product is used to start up the machinery. Do not use this product as a device for emergency stop.

Gentle start-up switches in accordance with ergonomics

Greater convenience with less stress on the hands.
Inventive start-up switches in accordance with ergonomics.

SW-101



Operate the switch simply by touching it

This is an optical-type switch (two beam axes) which allows you to start equipment simply by touching the sensing surface to interrupt the light beams.

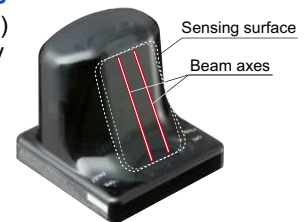

Reduces load on hands and fingers

Provides a zero force, low impact, machine control solution.

Prevents medical issues

The switch reduces the possibility of medical problems that are associated with high impact push buttons, such as tendonitis or carpal tunnel syndrome.

Reduction in false operation from dropped objects

SW-101

The response time is set for a slight delay so that the switch will not respond a falling object, such as a dropped tool. The switch is designed so that it will operate when touched by hand, but false operation will rarely occur when something is dropped onto it.

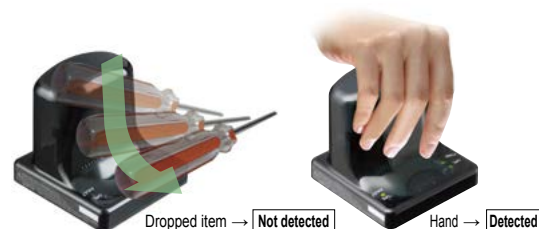

A switch that pursues the prevention requirement for malfunctioning as required by ISO 13851 (JIS B 9712) two-hand control devices

SW-111From
Push

To Grip

Safeguard prevents false operation

SW-111 saves the hassle of making an additional safeguard. In addition, with its ISO 13851 complying shape, even a knock on the elbow will not cause a false operation (light interruption).

No false operation by wrist



No false operation by elbow



No false operation by plastic sheet

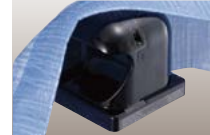

Experimental cone (ISO 13851)

SW-111 does not produce false operation on the experimental cone specified by ISO 13851.

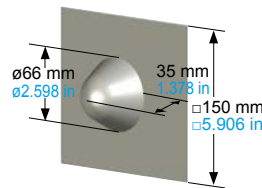

Intended startup is possible

SW-111

SW-111's detection does not operate when a hand is just placed onto the unit.

With a design that only detects when fingers are bent in and lightly grip onto the unit, an intended startup is possible.



Detection does not operate when a hand is only placed onto the unit.



Detection only operates when fingers are bent in and lightly grip onto the unit.

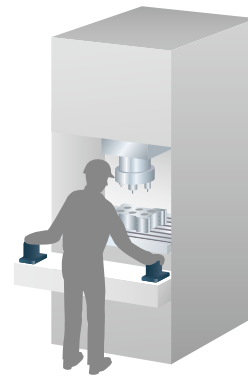

Application example

When used as two-hand control devices

Equipped with external input indicators

Two sets of external input indicators (two colors) are provided, so that they can be used as operation indicators for a variety of purposes.

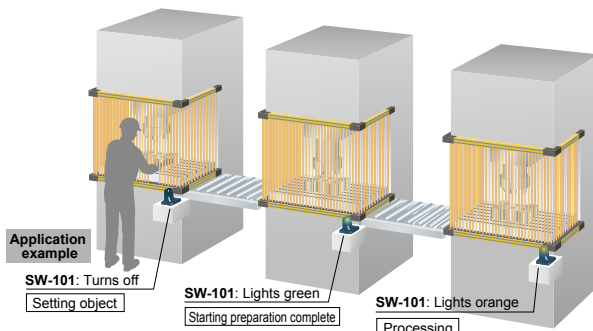

Application example

SW-101: Turns off
Setting object

SW-101: Lights green
Starting preparation complete

SW-101: Lights orange
Processing

Prevents false operation caused by dirt

If the light is continuously interrupted for more than 10 sec. by dust, etc., the switch is disabled and the fault indicator (yellow) illuminates.

Uses a long-life Photo-MOS relay

Because a Photo-MOS relay is used for the output, a single unit can be configured without a specific output polarity. In addition, there is no need for periodic replacement of parts such as contact-type relays.

FIBER SENSORS

LASER SENSORS

PHOTOELECTRIC SENSORS

MICRO PHOTOELECTRIC SENSORS

AREA SENSORS

SAFETY LIGHT CURTAINS / SAFETY COMPONENTS

PRESSURE / FLOW SENSORS

INDUCTIVE PROXIMITY SENSORS

PARTICULAR USE SENSORS

SENSOR OPTIONS

SIMPLE WIRE-SAVING UNITS

WIRE-SAVING SYSTEMS

MEASUREMENT SENSORS

STATIC CONTROL DEVICES

LASER MARKERS

PLC

HUMAN MACHINE INTERFACES

ENERGY MANAGEMENT SOLUTIONS

FA COMPONENTS

MACHINE VISION SYSTEMS

UV CURING SYSTEMS

Selection Guide

Safety Light Curtains



Safety Control Units

Safety Components

ST4**SW-100**

Safety Devices

ORDER GUIDE

Designation	Appearance	Model No.	Power supply	Output
Optical touch switch		SW-101	12 to 24V DC ±10 %	Semiconductor Photo-MOS relay output × 3
	With safeguard			

OPTIONS

Designation	Model No.	Description
Mounting tool	SW-MT1	Tool for tightening mounting nuts with a commercially-available wrench. (Refer to p.691)
Sensing surface protective sheet for SW-101	SW-PS1	A transparent stick-on sheet that protects the sensing surface of SW-101 from dirt and scratches. 5 sheets per set

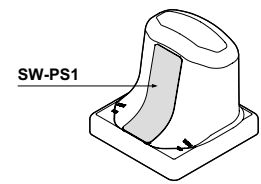
Sensing surface protective sheet for **SW-101****SPECIFICATIONS**

Item	Designation	Optical touch switch	
	Model No.	SW-101	With safeguard SW-111
Sensing method		Thru-beam type photoelectric sensor (2 beam axes)	
Applicable standards		CSA 22.2 No.14, CSA 22.2 No.0.8, ANSI/NFPA 79, UL 508, EN 60947-5-2 (EMC only)	
CE marking directive compliance		EMC Directive, RoHS Directive	
Power supply		12 to 24 V DC ±10 % Ripple P-P 10 % or less	
Current consumption		100 mA or less (excluding external connection load)	
Outputs		Semiconductor Photo-MOS relay output × 3 • Maximum load current: 100 mA • Applied voltage: 30 V DC or less (between output and +V) • Residual voltage: 1.5 V or less (at 100 mA of load current)	
	Output operation	Output 1 : When an object is detected (beam is interrupted): OFF / When an object is not detected (beam is received): ON Output 2, 3 : When an object is detected (beam is interrupted): ON / When an object is not detected (beam is received): OFF	
	Short-circuit protection	Incorporated	
Response time		100 ms or less when an object is detected, 50 ms or less when an object is not detected	
Time-out function		Switchable either effective or ineffective by short-circuiting terminals (disabled when short-circuited)	
External input		0 to 1 V or 10 V to +V: Valid (External input indicator lights up), 4 to 6 V or Open: Invalid (External input indicator lights off)	
Indicators	Power indicator (POWER)	Green LED (lights up when the power is ON)	
	Operation indicator (OPE.)	Green LED (lights up when an object is detected)	
	External input indicator 1	Green LED (lights up when external input 1 is valid)	
	External input indicator 2	Orange LED (lights up when external input 2 is valid)	
	Fault indicator (FAULT)	Yellow LED (blinks or lights up when fault occurs)	
Environmental resistance	Protection	IP65 (IEC), TYPE 1 (UL 50) (excluding terminal part)	
	Ambient temperature	-25 to +50 °C -13 to +122 °F (No dew condensation or icing allowed), Storage: -30 to +70 °C -22 to +158 °F	
	Ambient humidity	30 to 85 % RH, Storage: 30 to 85 % RH	
	Ambient illuminance	Incandescent light: 3,000 lx or less at the light-receiving face	
	Voltage withstandability	1,000 V AC for one min. between all supply terminals connected together and enclosure	
	Insulation resistance	20 MΩ, or more, with 500 V DC megger between all supply terminals connected together and enclosure	
	Vibration resistance	10 to 500 Hz frequency, 3 mm 0.118 in double amplitude in X, Y and Z directions for two hours each	10 to 150 Hz frequency, 0.75 mm 0.030 in double amplitude in X, Y and Z directions for two hours each
	Shock resistance	500 m/s ² acceleration (50 G approx.) in X, Y and Z directions three times each	
Removable-type terminals	Connector	3.5 mm 0.138 in pitch, 2-level socket: 12 pins	
	Terminal part	3.5 mm 0.138 in pitch spring-cage terminals: 6 pins × 2 (FMC1,5/6-ST-3,5GS manufactured by Phoenix Contact)	
Cable		0.2 to 1.5 mm ² [including single wire or ferrule (sleeve)]	
Maximum cable length		Up to 20 m 65.617 ft (for cable from 0.2 to 0.3 mm ²), Up to 100 m 328.084 ft (for cable from 0.3 to 1.5 mm ²)	
Material		Enclosure: Polycarbonate, Polyester, O-ring: Silicone rubber, Mounting nut: PBT, Mounting packing: Silicone rubber	
Weight		Net weight: 130 g approx., Gross weight: 200 g approx.	Net weight: 150 g approx., Gross weight: 220 g approx.

Note: Where measurement conditions have not been specified precisely, the conditions used were an ambient temperature of +23 °C +73.4 °F.

I/O CIRCUIT DIAGRAMS

I/O circuit diagram

If case of connecting output to Minus common

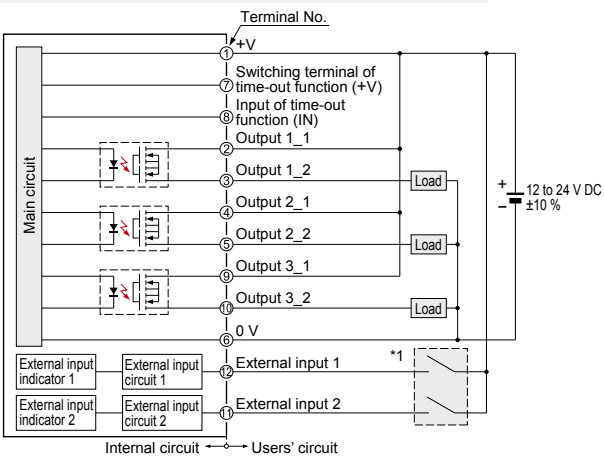

*1
Non-voltage contact or PNP open-collector transistor

 Contact "closed" or transistor "ON": Valid (External input indicator lights up)
 Contact "open" or transistor "OFF": Invalid (External input indicator lights off)

If case of connecting output to Plus common

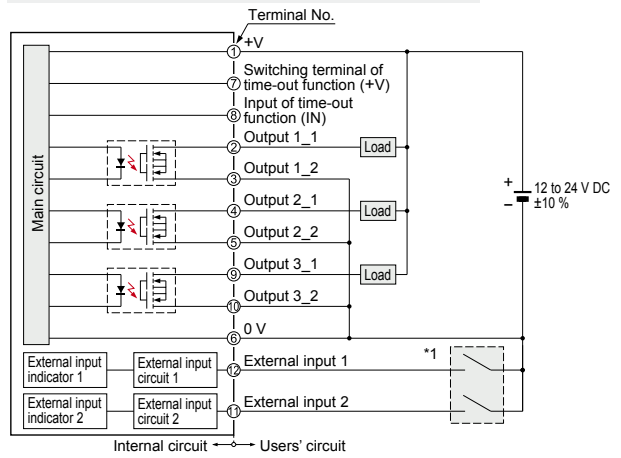

*1
Non-voltage contact or NPN open-collector transistor

 Contact "closed" or transistor "ON": Valid (External input indicator lights up)
 Contact "open" or transistor "OFF": Invalid (External input indicator lights off)

Terminal arrangement diagram

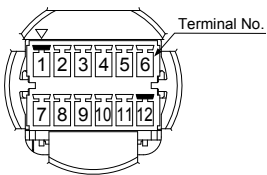

- FIBER SENSORS
- LASER SENSORS
- PHOTO-ELECTRIC SENSORS
- MICRO PHOTO-ELECTRIC SENSORS
- AREA SENSORS
- SAFETY LIGHT CURTAINS / SAFETY COMPONENTS
- PRESSURE / FLOW SENSORS
- INDUCTIVE PROXIMITY SENSORS
- PARTICULAR USE SENSORS
- SENSOR OPTIONS
- SIMPLE WIRE-SAVING UNITS
- WIRE-SAVING SYSTEMS
- MEASUREMENT SENSORS
- STATIC CONTROL DEVICES
- LASER MARKERS
- PLC
- HUMAN MACHINE INTERFACES
- ENERGY MANAGEMENT SOLUTIONS
- FA COMPONENTS
- MACHINE VISION SYSTEMS
- UV CURING SYSTEMS
- Selection Guide
- Safety Light Curtains
- Safety Control Units
- Safety Components

PRECAUTIONS FOR PROPER USE

Refer to p.1595 for general precautions.



- Never use this product in a device for personnel protection.
- In case of using devices for personnel protection, use products which meet laws and standards, such as OSHA, ANSI or IEC etc., for personnel protection applicable in each region or country.
- Do not use this product as a device for emergency stop.
- This product is used to start up the machinery. Securing safety for the start-up of machinery should be performed separately.
- When using the products for two-hand control, comply with the following contents.
- Select a model of a control device for two-hand control, based on results of risk assessment.
- Make sure to use a controller for two-hand control which complies with ISO 13851 (EN 574, JIS B 9712)
- For another requirements such as mounting of this product, or prevention of accidental actuation and of defeat etc., comply with ISO 13851 (EN 574, JIS B 9712) and ANSI B11.1, B11.9. Furthermore, comply with the regulations established by national or regional security committees (Occupational Safety and Health Administration: OSHA, the European Standardization Committee, etc.)

Time-out function

- Unintended beam interrupted status caused by dirt on the sensing surface, etc. can be monitored.
When beam interrupted status (sensing status) continues for 10 sec. or more, output 1 turns ON and output 2 and 3 turn OFF (output status is the same as non-sensing status.)
This function can be invalid by short-circuiting “between switching terminals of time-out function (terminal No. 7 and No. 8)” as described below.

Note: When time-out function is operated, the fault indicator (yellow) lights up. In this case, once beam is received, the fault indicator lights off and the sensor returns to normal operation.

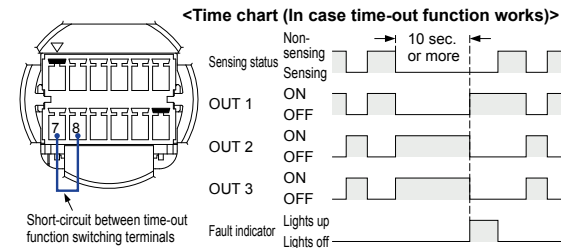

Others

- This device has been developed / produced for industrial use only.
- When the power of the thru-beam type photoelectric sensor inside the main body turns on in beam interrupted status, output 1 turns ON and output 2 and 3 turn OFF, then the fault indicator (yellow) lights up. In this case, once beam is received, the fault indicator lights off and the sensor returns to normal operation.
- Use a power supply unit conforming to the EMC Directive and the Low Voltage Directive. (Only for use in Europe)
- Use a power supply unit conforming to Class 2. (Only for use in the North America)
- Use a power supply unit with an output holding time of 20 ms or more.
- Do not use during the initial transient time (300 ms approx.) after the power supply is switched on.

Mounting

- Fasten a mounting nut (accessory) from the reverse side of the mounting plate. (Note 1)
The tightening torque should be 2 to 3 N·m.

Notes: 1) A mounting tool (**SW-MT1**) for fastening the mounting nut is available separately. The shape of fastening part of **SW-MT1** is M10 nut.
2) Make sure to use the attached mounting packing, or waterproof property will be invalid.

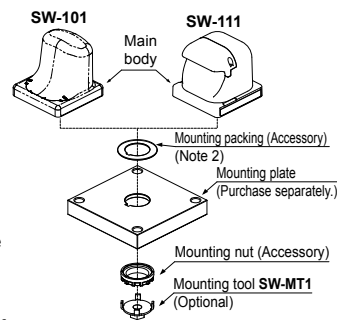

ST4

SW-100

Safety Devices

Selection Guide
Safety Light Curtains
Safety Control Units
Safety Components

UV CURING SYSTEMS

MACHINE VISION SYSTEMS

FA COMPONENTS

ENERGY MANAGEMENT SOLUTIONS

HUMAN MACHINE INTERFACES

PLC

LASER MARKERS

STATIC CONTROL DEVICES

MEASUREMENT SENSORS

WIRE-SAVING SYSTEMS

SIMPLE WIRE-SAVING UNITS

SENSOR OPTIONS

PARTICULAR USE SENSORS

INDUCTIVE PROXIMITY SENSORS

PRESSURE / FLOW SENSORS

AREA SENSORS

MICRO PHOTO-ELECTRIC SENSORS

PHOTO-ELECTRIC SENSORS

LASER SENSORS

FIBER SENSORS

DIMENSIONS (Unit: mm in)

The CAD data can be downloaded from our website.

SW-101

Optical touch switch

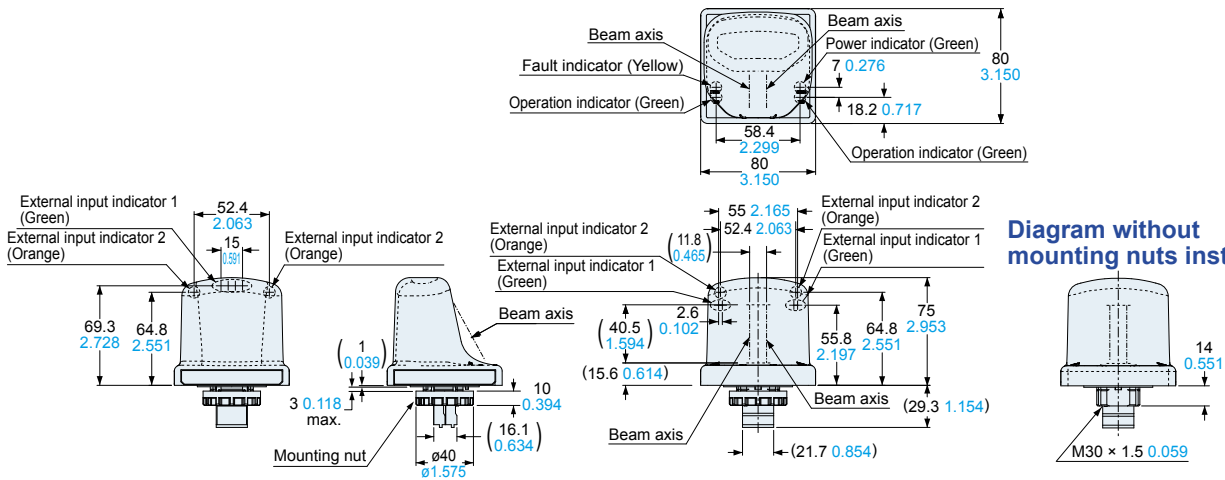

Panel cut-out dimensions

<When mounting with a resin plate>

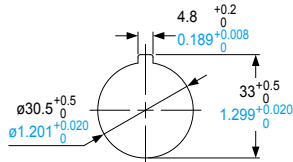

<When mounting with a metal plate>

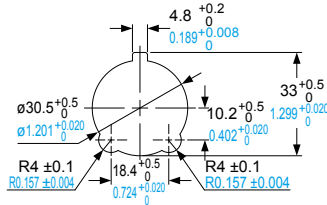

Note: The panel thickness should be 3 mm 0.118 in or less.

SW-111

Optical touch switch

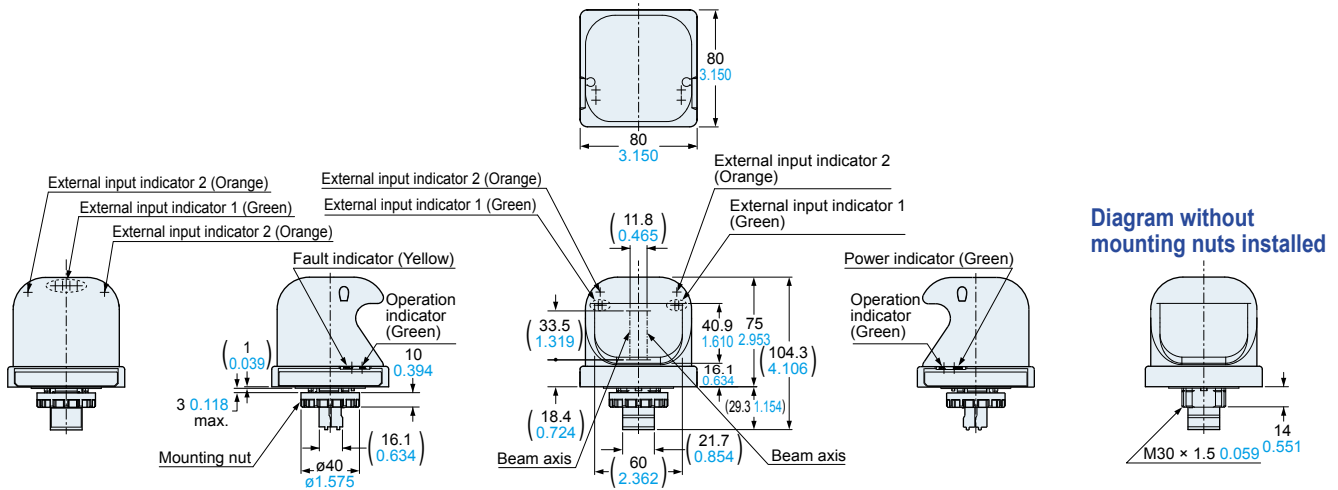

Panel cut-out dimensions

<When mounting with a resin plate>

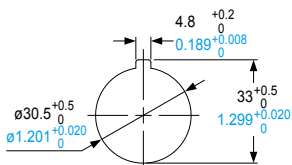

<When mounting with a metal plate>

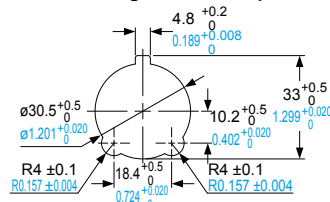

Note: The panel thickness should be 3 mm 0.118 in or less.

- FIBER SENSORS
- LASER SENSORS
- PHOTO-ELECTRIC SENSORS
- MICRO PHOTO-ELECTRIC SENSORS
- AREA SENSORS
- SAFETY LIGHT CURTAINS / SAFETY COMPONENTS
- PRESSURE / FLOW SENSORS
- INDUCTIVE PROXIMITY SENSORS
- PARTICULAR USE SENSORS
- SENSOR OPTIONS
- SIMPLE WIRE-SAVING UNITS
- WIRE-SAVING SYSTEMS
- MEASUREMENT SENSORS
- STATIC CONTROL DEVICES
- LASER MARKERS
- PLC
- HUMAN MACHINE INTERFACES
- ENERGY MANAGEMENT SOLUTIONS
- FA COMPONENTS
- MACHINE VISION SYSTEMS
- UV CURING SYSTEMS
- Selection Guide
- Safety Light Curtains
- Safety Control Units
- Safety Components
- ST4**
- SW-100**
- Safety Devices**