

Optical Touch Switch  
**SW-111**

MJE-SW111 No.0034-07V

Thank you very much for purchasing Panasonic products. Read this Instruction Manual carefully and thoroughly for the correct and optimum use of this product. Kindly keep this manual in a convenient place for quick reference.

**WARNING**

- Never use this product in a device for personnel protection.
- In case of using devices for personnel protection, use products which meet laws and standards, such as OSHA, ANSI or IEC etc., for personnel protection applicable in each region or country.
- Do not use this product as a device for emergency stop.
- This product is used to start up the machinery. Securing safety for the start-up of machinery should be performed separately.
- When using the products for two-hand control, comply with the following contents.
  - Select a model of a control device for two-hand control, based on results of risk assessment.
  - Make sure to use a controller for two-hand control which complies with ISO 13851 (EN 574.)
  - For another requirements such as mounting of this product, or prevention of accidental actuation and of defeat etc., comply with ISO 13851 (EN 574, JIS B 9712) and ANSI B11.1, B11.9. Furthermore, comply with the regulations established by national or regional security committees (Occupational Safety and Health Administration: OSHA, the European Standardization Committee, etc.)

**1 OUTLINE**

- This product is an optical touch switch which detects a hand by a thru-beam type photoelectric sensor.
- When gripping the sensing surface of the product by a hand to interrupt the light beam, output turns ON or OFF.

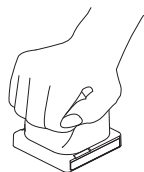

**2 FUNCTIONAL DESCRIPTION**

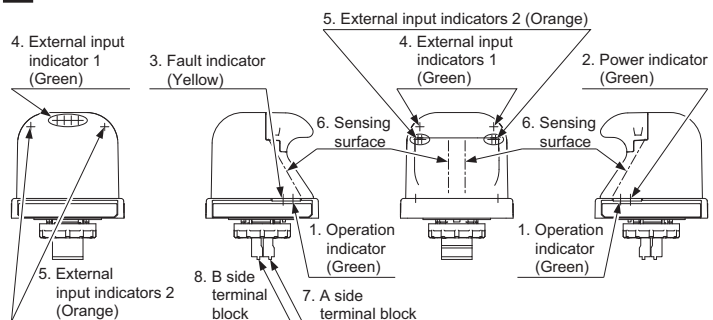

Designation	Function
1 Operation indicator × 2 (Green)	Lights up when an object is detected.
2 Power indicator (Green)	Lights up when the power is ON.
3 Fault indicator (Yellow)	Blinks or lights up when fault occurs. Refer to "6 TROUBLESHOOTING" for details in blinking operation.
4 External input indicator 1 × 3 (Green)	Lights up when external input 1 is valid. Refer to "5 FUNCTIONS" for details.
5 External input indicator 2 × 4 (Orange)	Lights up when external input 2 is valid. Refer to "5 FUNCTIONS" for details.
6 Sensing surface	Thru-beam type photoelectric sensor is incorporated in the sensing surface. Thus, when the light beam is interrupted by fingers, the sensor goes into the beam interrupted condition and output turns ON or OFF.
7 A side terminal block	Connects +V, output 1, 2 and 0V.
8 B side terminal block	Connects switching terminals of time-out function, output 3, and external input 1, 2.

**3 MOUNTING**

- Follow the procedures below when mounting this product on a mounting plate.

**Procedures**

1. Drill a hole in a mounting plate (thickness: 3mm or less.)

Dimensions of a mounting hole to be drilled when mounting on a resin plate (Unit: mm)

Dimensions of a mounting hole to be drilled when mounting on a metal plate (Unit: mm)

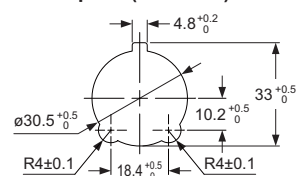
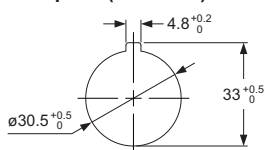

**<Bottom of the product (Unit: mm)>**

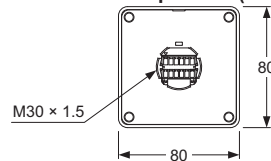

2. Make sure to fit a mounting packing (accessory) to the terminal area of the main body first, then put the main body into the mounting plate. (Note 1)

**<Fitting diagram of the mounting packing>**

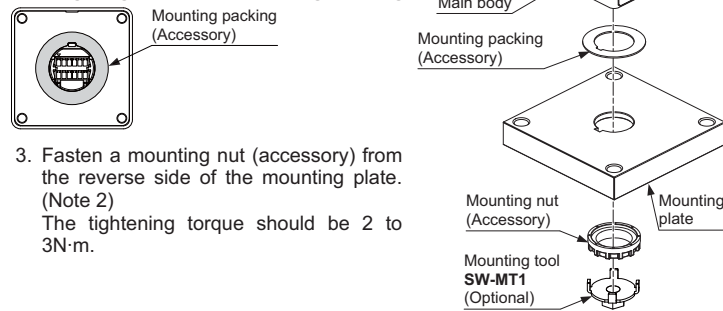

3. Fasten a mounting nut (accessory) from the reverse side of the mounting plate. (Note 2)  
The tightening torque should be 2 to 3N·m.
- Notes: 1) Make sure to use the mounting packing (accessory), or waterproof property will be invalid.  
2) A mounting tool **SW-MT1** for fastening the mounting nut is available separately. The shape of fastening part of **SW-MT1** is M10 nut.  
3) When using the products for two-hand control, be sure to mount the products by complying with ISO 13851 (EN 574, JIS B 9712) and ANSI B11.1, B11.9. In addition, be sure to use a controller for two-hand control which complies with ISO 13851 (EN 574, JIS B 9712).

**4 I/O CIRCUIT DIAGRAMS**

**<In case of Minus Common>**

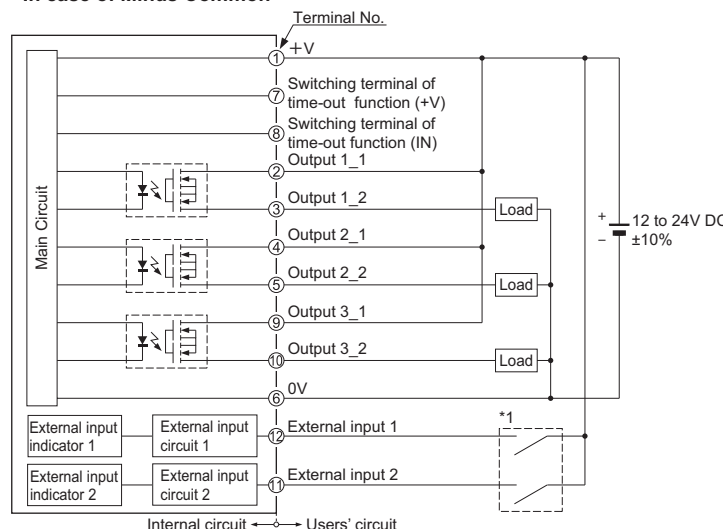

**<In case of Plus Common>**

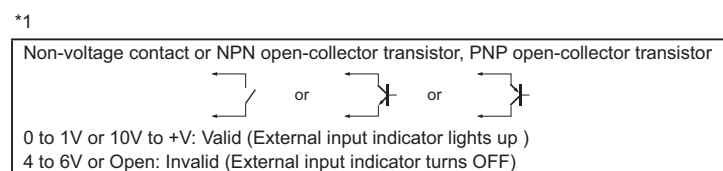
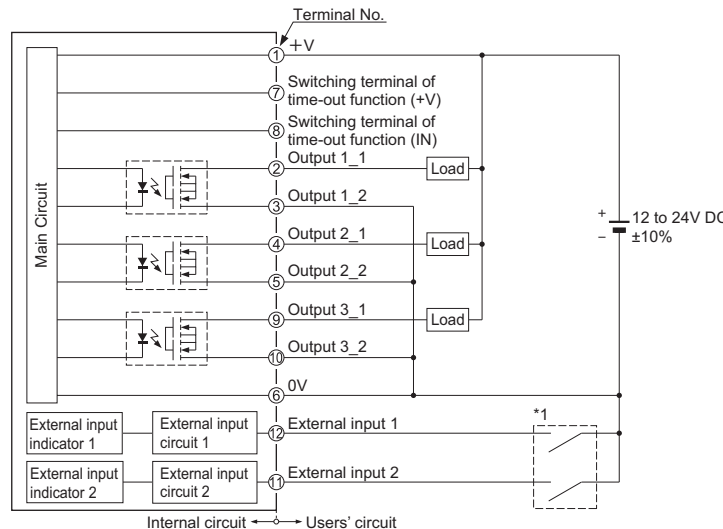

**Terminal layout**

- As the shape is different between A side terminal (terminal No. 1 to 6) and B side terminal (terminal No. 7 to 12), make sure to wire properly.

**A side terminal block**

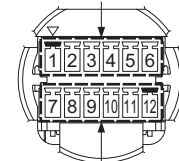

**B side terminal block**

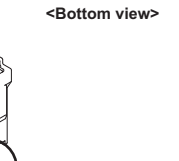

**<A side terminal block>**

Terminal No.	Terminal name	Description
1	12 to 24V DC	+V
2	Output 1	Output 1_1 Output 1_2
3	Output 2	Output 2_1 Output 2_2
4	Output 3	Output 3_1 Output 3_2
5	IN2 (Orange)	External input 2
6	0V	0V

**<B side terminal block>**

Terminal No.	Terminal name	Description
7	Timer (+V)	Switching terminal of time-out function (+V)
8	Timer (IN)	Switching terminal of time-out function (IN)
9	Output 3	Output 3_1 Output 3_2
10	IN2 (Orange)	External input 2
11	IN1 (Green)	External input 1
12	IN1 (Green)	External input 1

**Connecting to the terminal block**

- When connecting to the terminal block, push the cable with ferrule terminal into the back of the mounting hole. If the cable is properly inserted, the lock is completed and the cable does not fall if it is pulled.
- In case of using twisted wire directly, hold down the release button and plug the cable into the back as shown in the right figure. Conforming cable diameter is shown below.
- In case of removing, hold down the release button and pull the cable.

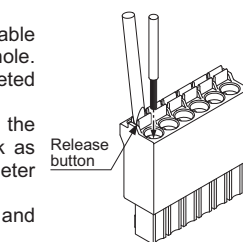

**<Conforming cable>**

Cable with no ferrule terminal (Twisted wire)	Cable with ferrule terminal
0.2 to 1.5mm <sup>2</sup> (AWG 24 to 16)	0.2 to 1.5mm <sup>2</sup>

**5 FUNCTIONS**

**1. Basic operation**

- Thru-beam type photoelectric sensor is incorporated in the sensing surface. Thus, when the light beam is interrupted by fingers, the sensor goes into the beam interrupted condition and output turns ON or OFF.
- 2. Output**
- Three semiconductor photo MOS relays are incorporated.
  - Output 1 : When an object is detected (beam is interrupted): OFF / When an object is not detected (beam is received): ON
  - Output 2, 3: When an object is detected (beam is interrupted): ON / When an object is not detected (beam is received): OFF

Note: When the power of the thru-beam type photoelectric sensor inside the main body turns ON in beam interrupted condition, output 1 turns ON, while outputs 2 and 3 turn OFF, then the fault indicator (yellow) lights up. In this case, once beam is received, the fault indicator turns OFF and the sensor returns to normal operation.

**3. Time-out function**

- Unintended beam interrupted condition caused by dirt on the sensing surface, etc. can be monitored.
    - When beam interrupted condition (sensing condition) continues for 10 sec. or more, output 1 turns ON, while output 2 and 3 turn OFF (output condition is the same as non-sensing condition.)
    - This function can be invalid by short-circuiting "between switching terminals of time-out function (terminal No. 7 and No. 8)" as described below.
- Note: When time-out function is operated, the fault indicator (yellow) lights up. In this case, once beam is received, the fault indicator turns OFF and the sensor returns to normal operation.

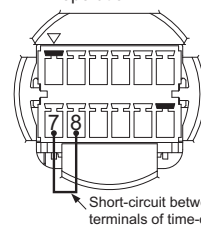

**<Timing Chart (In case time-out function works)>**

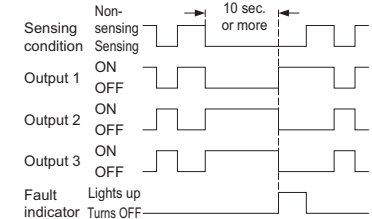

**4. External input function**

- External input indicators 1 and 2 of this product light up by the signal from external input.
- External input indicators 1 and 2:  
Lights up when external input indicators 1 and 2 are valid (0 to 1V or 10V to +V). Turns OFF when external input indicators 1 and 2 are invalid (4 to 6V or open).

**6 TROUBLESHOOTING**

- Fault indicator (yellow) blinks when an error occurs.
- An error can be identified by the number of blinks of the fault indicator.

Blinking number	Error	Status of sensor	Countermeasure
1	Output short-circuit	Lockout	Check the wiring of output.
2	Dirt error	Normal operation	Wipe out the sensing surface with a soft cloth.
4	Extraneous light error	Lockout	Place the product so that extraneous light is not received at its sensing surface.
5	Internal error	Lockout	Check that there is no noise around the product. Also check the environment for power supply and wiring.
6	Emission circuit error	Lockout	In case the product does not operate normally after checking the above measures, contact Panasonic Industrial Devices SUNX Co., Ltd.
7	Reception circuit error	Lockout	In case the product does not operate normally after checking the above measures, contact Panasonic Industrial Devices SUNX Co., Ltd.

- In case of lockout condition, when upper countermeasure is performed and the power is supplied again, the operation returns to normal.

**<Blinking cycle of the fault indicator [(e.g.) The number of blinks: 2 times]>**

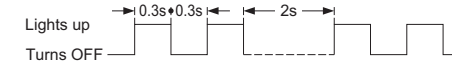

**7 SPECIFICATIONS**

Designation	Optical touch switch
Item	Model No. <b>SW-111</b>
Applicable standard	CSA 22.2 No.14, CSA 22.2 No.0.8, ANSI/NFPA 79, UL 508, EN 60947-5-2 (EMC only)
Sensing method	Thru-beam type photoelectric sensor (2 beam axes)
Supply voltage	12 to 24V DC±10%, Ripple P-P10% or less
Current consumption	100mA or less (Excluding external connection load)
Output	Semiconductor photo MOS relay output × 3 • Maximum load current: 100mA • Applied voltage: 30V DC or less (between output and +V) • Residual voltage: 1.5V or less (at 100mA of load current)
Output operation	Output 1 : When an object is detected (light is blocked): OFF / When an object is not detected (light is received): ON Output 2, 3 : When an object is detected (light is blocked): ON / When an object is not detected (light is received): OFF
Short-circuit protection	Incorporated
Response time	100ms or less when an object is detected 50ms or less when an object is not detected
Protection	IP65 (IEC) TYPE1 (UL 50) (Excluding terminal area)
Ambient temperature	-25 to +50°C (No dew condensation or icing allowed) Storage: -30 to +70°C
Ambient humidity	30 to 85% RH, Storage: 30 to 85% RH
Material	Enclosure: Polycarbonate, Polyester resin Nut: PBT, Mounting packing: Silicone rubber
Connection cable length	Up to 20m (cable diameter: 0.2 to under 0.3mm <sup>2</sup> ) Up to 100m (cable diameter: 0.3 or more to 1.5mm <sup>2</sup> )
Weight	Approx. 200g

**8 CAUTIONS**

- This product has been developed / produced for industrial use only.
- Confirm the wiring before power is supplied, as wrong wiring will damage the internal circuit.
- Verify that the supply voltage variation is within the rating.
- If power is supplied from a commercial switching regulator, ensure that the frame ground (F.G.) terminal of the power supply is connected to an actual ground.
- Use a power supply unit conforming to the EMC Directive and the Low Voltage Directive. (Only for use in Europe)
- Use a power supply unit conforming to CLASS 2. (Only for use in the United States)
- Use a power supply unit with an output holding time of 20ms or more.
- Do not use during the initial transient time (approx. 300ms) after the power supply is switched ON.
- Make sure to use an isolation transformer for the DC power supply. If an auto-transformer (single winding transformer) is used, this product or the power supply may get damaged.
- In case a surge is generated in the used power supply, connect a surge absorber to the source and absorb the surge.
- Make sure that the power is OFF while wiring.
- Do not run the wires together with high-voltage lines or power lines or put them in the same raceway. This can cause malfunction due to induction.
- In order to reduce noise, make the wiring as short as possible.
- Do not use this product in places having excessive vapor, dust, etc.
- Take care that the product does not come in contact with oil, grease, or organic solvents such as thinner, etc.
- Do not hit the product by a hammer etc. when mounting, as the product get damaged.
- This product is suitable for indoor use only.

**9 INTENDED PRODUCTS FOR CE MARKING**

- The models listed under "7 SPECIFICATIONS" come with CE Marking. As for all other models, please contact our office.
- **Contact for CE**  
<Until June 30 ,2013>  
Panasonic Electric Works Europe AG  
Rudolf-Diesel-Ring 2, D-83607 Holzkirchen, Germany  
<From July 1 ,2013>  
Panasonic Marketing Europe GmbH Panasonic Testing Center  
Winsbergring 15, 22525 Hamburg, Germany

**Panasonic Industrial Devices SUNX Co., Ltd.**

http://panasonic.net/id/pidsx/global  
**Overseas Sales Division (Head Office)**  
2431-1 Ushiyama-cho, Kasugai-shi, Aichi, 486-0901, Japan  
Phone: +81-568-33-7861 FAX: +81-568-33-8591

About our sale network, please visit our website.