

NEW

OMRON

Static Sensors and Ionizers

Series Catalog

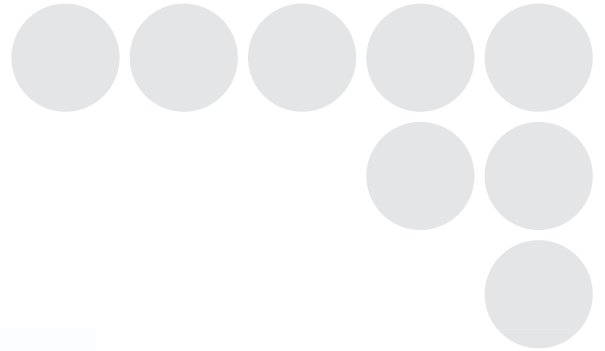

"Visible" Static Electricity

Measuring Static Electricity In-line



Thorough Ionization

Best Ion Balance in its Class

realizing



from the FACTORY

Sensing and Control of Static Electricity

With the ever-diminishing size of components and greater detail in electronic devices, countermeasures for static electricity have become vitally important for increasing product quality and production yield on production sites. The real problems are how to make invisible static electricity "visible" and how to effectively remove it.

OMRON can help you fight static electricity and increase product quality with our High-performance Ionizers, which are based on sensing static electricity combined with the highest class of ionization performance.



for High Quality Products

Making Static Electricity Visible

Sensing

Direct Display of Static Level ZJ-SD100/ZJ-SDA11 Electrostatic Sensor

The compact Sensor Head (6 × 6 × 67 mm) and intelligent Digital Amplifier combine to visually display the static level of the workpiece. You can measure more than one point and easily log static levels on a personal computer. Static levels can be measured accurately by using a displacement sensor for distance and workpiece area compensation.

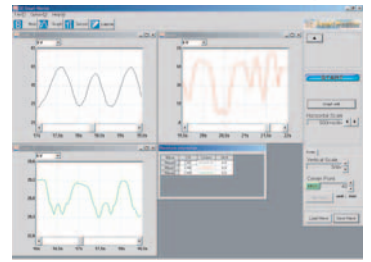

Static Countermeasures while Measuring and Logging Multiple Locations

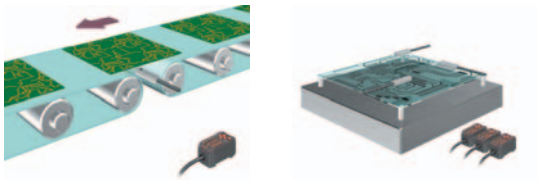

Measuring Static on PCBs on Conveyors Measuring Static on LCB Boards

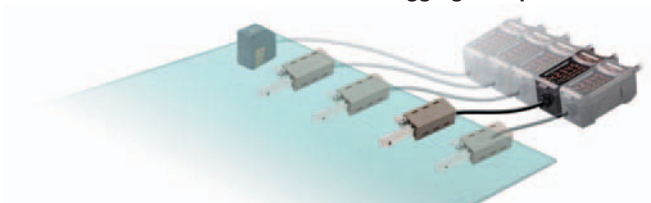

Accurate Sensing at Long Distances with an Ultra-compact Design

High-speed, High-performance Ionization

Ionizer

Fan Type

In Cell Production Lines and Assembly Devices

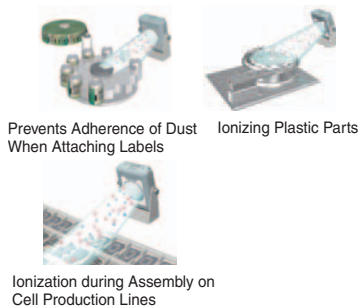

Prevents Adherence of Dust When Attaching Labels Ionizing Plastic Parts
Ionization during Assembly on Cell Production Lines

Simple, High-speed Ionization

ZJ-FA20 Basic Fan-type Ionizer

- High-speed ionization in 0.8 s.
- Long-term stable ion balance.
- Fully open structure for easy, worry-free maintenance.



Bar Type

For Clean Processing without Disrupting Conveying or Downflow.

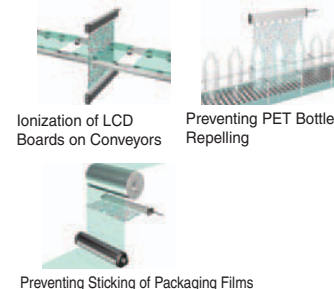

Ionization of LCD Boards on Conveyors Preventing PET Bottle Repelling
Preventing Sticking of Packaging Films

High-speed, Consistent Ionization over Wide Areas

ZJ-BAS Digital Bar-type Ionizer

- Ideal design for high-speed, thorough ionization at a long distance and over a wide area.
- Consistent ionization over a wide area with a linked structure.
- Simple, worry-free setting with setting guide on a digital ion display.



Blow Type

For Ionizing Spots or Gaps

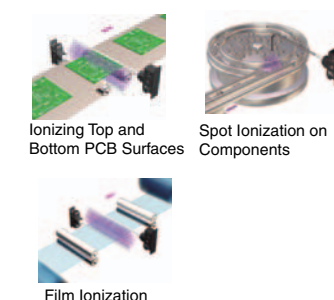

Ionizing Top and Bottom PCB Surfaces Spot Ionization on Components
Film Ionization

Compact, with High Performance

KS1 Air Push-type Ionizer

- A wide range of Nozzles for installation in various locations in equipment.
- High-frequency AC system for superior ion balance.
- Standard-feature alarm output for errors.

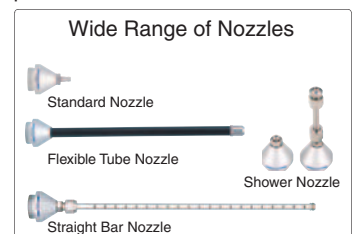

ZJ-SD

from the FACTORY

Smart Electrostatic Sensor
ZJ-SD Series

Smart Static Electricity Sensing: Making Static Electricity Visible

The unpredictable nature of static electricity creates the need for a sensor for constant in-line monitoring to properly capture static electricity. Smart collection of effective data to improve production site countermeasures is now possible.



Smart In-line Measurement of Production Site Static Electricity

Compact Sensor Head and Smart Amplifier

Hand-held devices and large measuring devices are not suitable for easily measuring static charges of workpieces in-line. The Sensor Head of the Smart Electrostatic Sensor is small (6 × 6 × 67 mm) and the bracket has a rotating mechanism, making it possible to mount it even where space is limited.

Compact Sensor Head

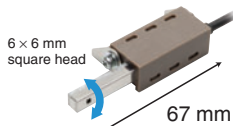

The bracket on the Head enables changing the sensing direction even after installation.

Smart Amplifier



Direct display of static charge

Smart Static Electricity Monitoring

For effective discharge, measurements must be made at more than one location and changes over time need to be monitored. With the ZJ-SD, multi-point measurements from up to 5 Units can be made easily if a Calculating Unit is connected between Amplifiers. And the Electrostatic Sensor measurement data can be displayed and logged on a personal computer via an Interface Unit and used for static electricity countermeasures.

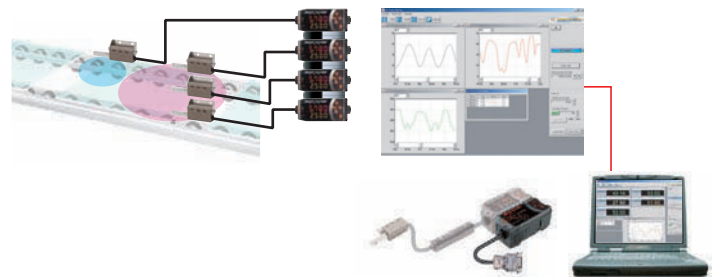

Our Highest Priority: Easy Onsite Operation

Simple Settings Using Key Operations

A seven-segment, two-row display is provided for workpiece charge and threshold displays. Settings are easy to make using Up, Down, Left, and Right Keys.

Judgment Output Indicators

OPE1, OPE2, and OPE3 three-color indicators

Intuitive Operation Using Up, Down, Left, and Right Keys.

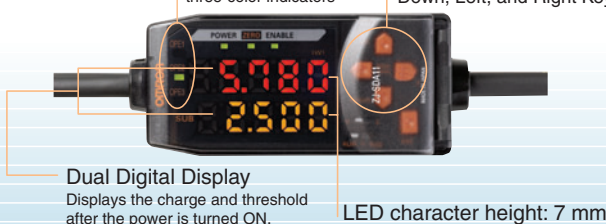

Dual Digital Display
Displays the charge and threshold after the power is turned ON.

LED character height: 7 mm

Remote Detection

Use the ZX-XC□A (order separately) to extend the cable to 2, 5, or 9 m.

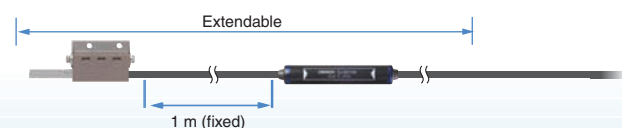

Smart Sensing

Best Long-distance, High-precision Measurements in the Industry

The ZJ-SD provides the highest detection accuracy in the industry when combined with a ZX Displacement Sensor. And even more precise measurements are possible with the compensation function that adjusts to the size of the workpiece.

Workpiece Distance Compensation

Long-distance, High-precision Measurements

The best sensing range in the industry at 100 mm/ ±50 kV. Sensors that measure static charges are greatly affected by the measurement distance. The ZJ-SD solves this problem by combining with a ZX-series Displacement Sensor to enable communicating distance information and thus achieve high-accuracy measurements.

Note: Ultrasonic Displacement Sensors are also available. Contact your OMRON representative for details.

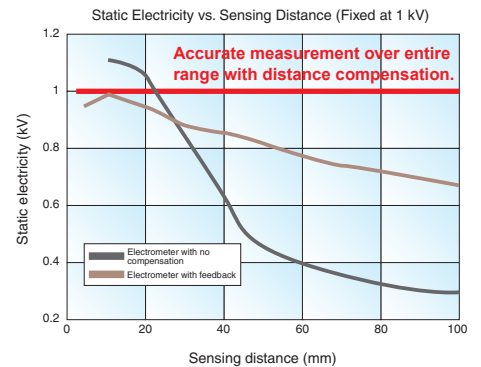
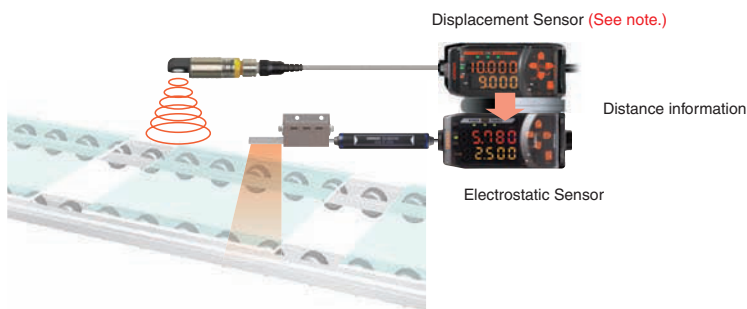

Unaffected by Measurement Distance

In addition to distance data compensation performed by the Displacement Sensor, errors from distance fluctuations can also be reduced by directly inputting the installation distance into the Amplifier.

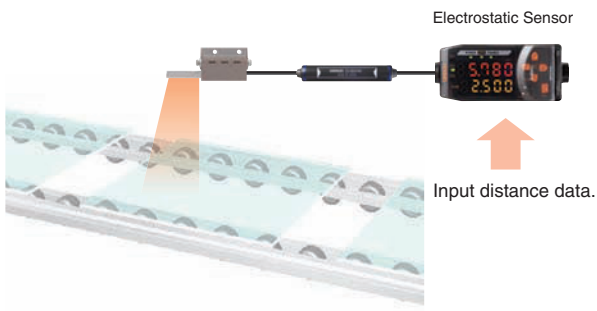

Workpiece Size Compensation

Accurate Static Charge Measurements for Small Workpieces

The Electrostatic Sensor's sensing area is approximately five times the installation distance. Enter the workpiece size to measure the static charge of workpieces smaller than the sensing area. (See note.) The ZJ-SD can compensate the static charge based on a comparison of the installation distance recorded in the Pre-amplifier and the size of the sensing area.

Note: Except for the workpiece, static charge inside the sensing area must be 0 V. Use a measurement error of approximately 10% as a guide for a measurement distance of 5 mm and a workpiece of 10 mm in diameter.

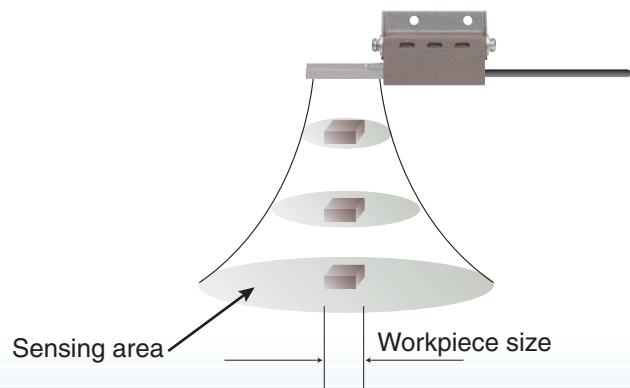

*Long distance,
Highly accurate detection*

Ordering Information

Electrostatic Sensor

Sensor Head

Appearance	Sensing distance	Model
	5 to 100 mm	ZJ-SD100

Accessories (Order Separately)

Calculating Unit

Appearance	Model
	ZX-CAL2



SmartMonitor Sensor Setup Tool for Personal Computer Connection

Appearance	Name	Model
 +CD-ROM	Communications Interface Unit and software for setup and display	ZJ-SFW11

Amplifier

Appearance	Cable length	Power supply	Output method	Model
	2 m	DC	NPN output	ZJ-SDA11

Preamplifier Mounting Brackets

Appearance	Model	Remarks
	ZX-XBT1	Included with Sensor Head.
	ZX-XBT2	For DIN Track mounting

Cables with Connectors on Both Ends (for Extension)

Cable length	Model	Quantity
1 m	ZX-XC1A	1
4 m	ZX-XC4A	
8 m	ZX-XC8A	

Sensor Head Mounting Bracket for Distance Compensation

Appearance	Model	Remarks
	ZJ-XBU1	Used for distance compensation using a Displacement Sensor.

Specifications

Sensor Head

Item	Model	ZJ-SD100
Applicable Amplifier		ZJ-SDA11
Sensing distance		5 to 100 mm
Measurement voltage		Standard mode: ± 50 KV, Precision mode: ± 5 KV max. (See note 1.)
Display resolution		Standard mode: 10 V, Precision mode: 1 V (See note 2.)
Linearity (See note 3.)		$\pm 5\%$ FS (See note 4.)
Response time		20 ms
Ambient temperature range		Operating and storage: 0 to 50°C (with no condensation or icing)
Ambient humidity range		Operating and storage: 35% to 85% (with no condensation)
Dielectric strength		1,000 VAC, 50/60 Hz, 1 min (See note 5.)
Vibration resistance		Sensor Head: 3-mm double amplitude at 10 to 55 Hz for 45 min each in the X, Y, and Z directions, Preamplifier: 1.5-mm double amplitude at 10 to 55 Hz for 2 h each in the X, Y, and Z directions
Degree of protection		IP20
Connection method		Pre-wired Connector (standard length: 2 m)
Weight (packed state)		Approx. 150 g
Materials		Sensor Head: Stainless steel Preamplifier: PC
Accessories		Instruction sheet, Preamplifier Mounting Brackets (ZX-XBT1)

- Note 1. Even within the measurement voltage range, the measurement may become saturated if the Sensor is too close to the object being measured. If that happens, the display value will remain almost constant. Use the distance from the measurement surface (mm) times 1 KV as a guide.
 2. This is the minimum value obtainable when a ZJ-SDA11 Amplifier Unit is connected.
 3. When the ambient temperature is stable at 25°C.
 4. When the measurement distance is 10 mm and the measurement voltage is -5 to 5 KV.
 5. When a Preamplifier is used (excluding the Sensor Head).

Ionizer

Item	Model	ZJ-SDA11
Measurement period		1 ms
Possible average count settings (See note 1.)		1, 2, 4, 8, 16, 32, 64, 128, 256, 512, or 1,024
Linear output (See note 2.)		Current output: 4 to 20 mA/FS, Max. load resistance: 300 Ω Voltage output: ± 4 V (± 5 V, 1 to 5 V (See note 3.)), Output impedance: 100 Ω
Judgment outputs (3 outputs: OPE1, OPE2, and OPE3)		NPN open-collector output, 30 VDC, 20 mA max. Residual voltage: 1.2 V max.
Bank shift input, zero reset input, timing input, reset input		ON: Short-circuited with 0-V terminal or 1.5 V or less OFF: Open (leakage current: 0.1 mA max.)
Functions		Measurement value display, display reverse, scaling, peak and bottom hold, distance compensation, present value display, limit number of display digits, monitor focus, mask hold, sensing area compensation, output value display, zero reset, linear output compensation, distance trigger, warning output, setting value display, zero reset memory, peak hold, delay hold, bank switching, resolution display, various timers, bottom hold, delay time setting, enable display, initialization, sample hold, timing inputs, zero reset display, teaching, peak-to-peak, key lock, judgment output display, direct threshold value setting, hold, clamp value setting, ECO mode, hysteresis adjustment, average hold, precise measurement mode
Indications		Operation indicators (OPE1 (orange), OPE2 (green), OPE3 (yellow), 7-segment main digital display (red), 7-segment sub-digital display (yellow), power ON indicator (green), zero reset indicator (green), enable indicator (green)
Power supply voltage		24 VDC $\pm 10\%$, Ripple (p-p): 10% max.
Current consumption		24-VDC power supply: 140 mA max.
Ambient temperature range		Operating and storage: 0 to 50°C (with no icing or condensation)
Ambient humidity range		Operating and storage: 35% to 85% (with no condensation)
Insulation resistance		20 M Ω (at 500 VDC)
Dielectric strength		1,000 VAC, 50/60 Hz, 1 min
Shock resistance		Destruction: 300 m/s ² 3 times each in 6 directions (up/down, left/right, and forward/backward)
Vibration resistance		Destruction: 0.7-mm double amplitude at 10 to 150 Hz for 80 min each in the X, Y, and Z directions
Connection method		Pre-wired (standard length: 2 m)
Weight (packed state)		Approx. 350 g
Materials		Case: PBT (polybutylene terephthalate), Cover: Polycarbonate
Accessories		Instruction sheet

- Note 1. The response time of the linear outputs is calculated as follows: Measurement period \times (Average count setting + 1).
 The response time of the judgment outputs is calculated as follows: Measurement period \times (Average count setting + 1).
 2. The output can be switched between a current output and voltage output using a switch on the bottom of the Amplifier.
 3. Setting is possible using the monitor focus function.

Engineering Data (Reference Value)

Measurement Voltage vs. Linearity

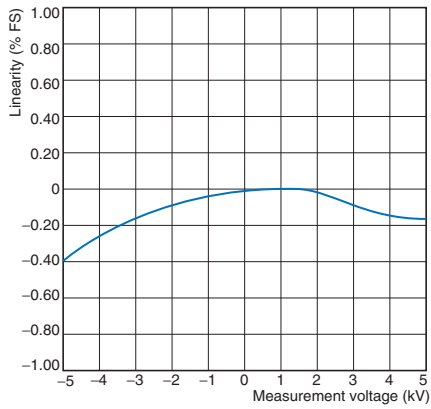

Measurement object: Charged plate (150 × 150 mm, 20 pF)
 Measurement distance: 10 mm
 Measurement mode: Standard

Measurement Distance vs. Error

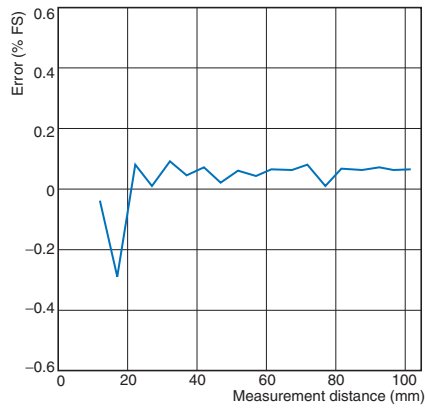

Measurement object: Charged plate (150 × 150 mm, 20 pF)
 Measurement voltage: 5 kV
 Measurement mode: Standard
 Measurement after teaching the measurement distance to the Amplifier.

Dimensions

(Unit: mm)

Electrostatic Sensor

Sensor Head
ZJ-SD100

Angle 1

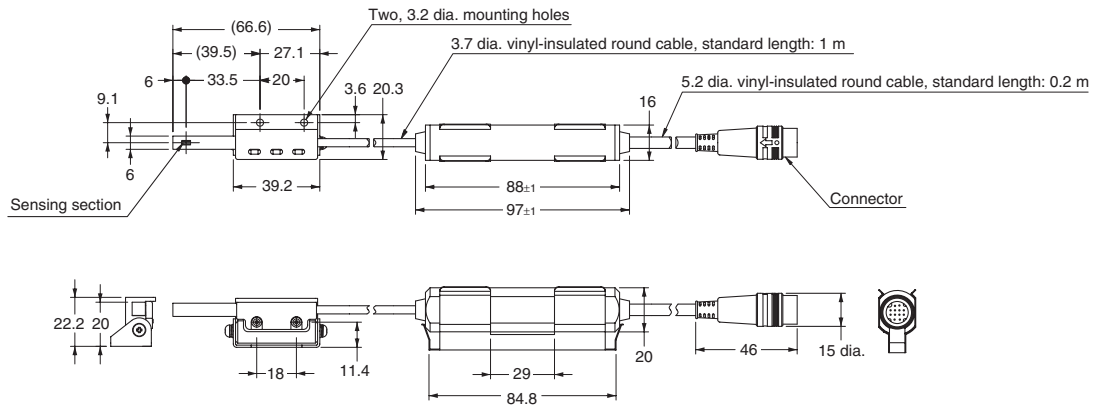

Angle 2

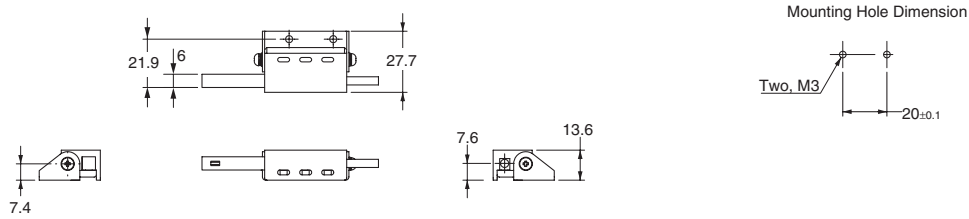

Amplifier
ZJ-SDA11

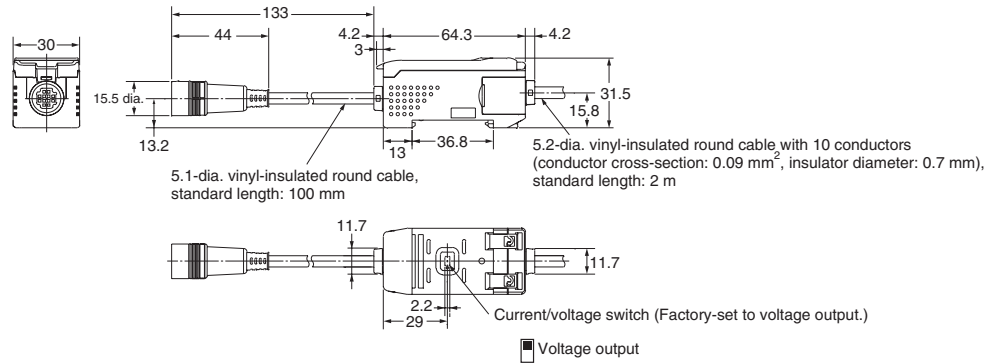

Accessories (Order Separately)

Preamplifier Mounting Brackets

ZX-XBT1

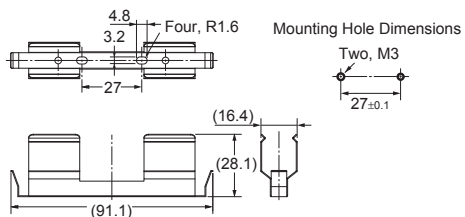

Material: Stainless steel

ZX-XBT2

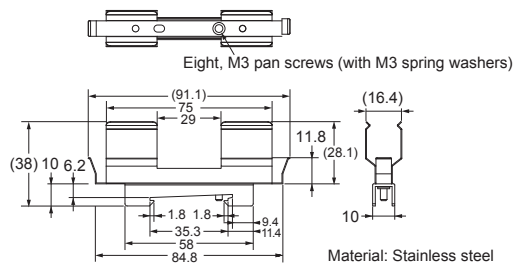

Material: Stainless steel

Sensor Head Mounting Bracket for Distance Compensation

ZJ-XBU1

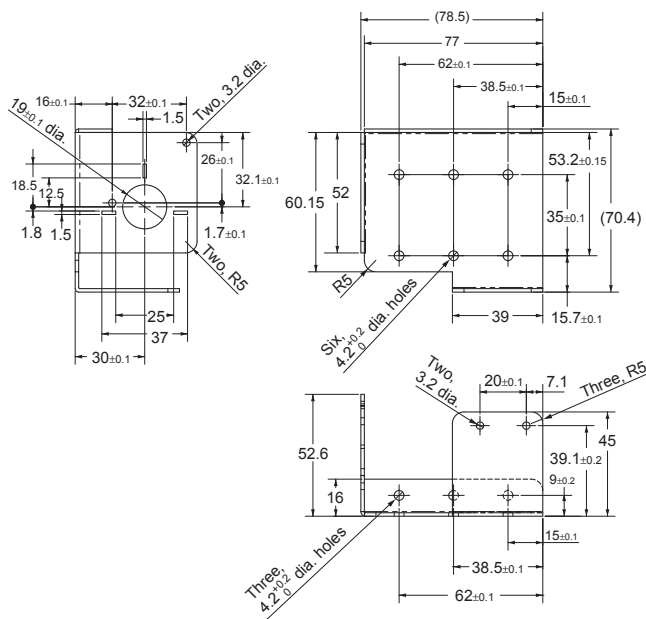

■ Dimensions with ZX-LD100 Sensor Head

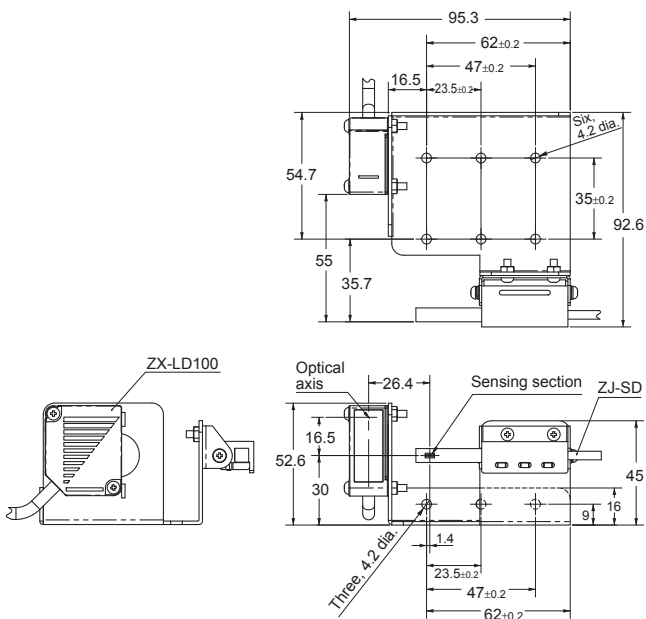

ZJ-FA20

from the FACTORY

High-performance, Low-price Standard Ionizer

Achieve a High-performance, Reliable Ionization Environment at a Reasonable Investment



Ionizer

Basic Fan Type

ZJ-FA20

High-speed Ionization

A Unique Structure Provides a Uniform Airflow

The newly developed airflow control system (AFCS) structure optimally controls the airflow of the fan to efficiently carry the discharged ions to the target workpiece. This gives the ZJ-FA20 the highest ionization performance in its class. Even with the airflow at a low setting, ionization is completed in approximately 2 seconds. Small, light workpieces are not blown away by the airflow, and static electricity is effectively neutralized.

Airflow Control System (AFCS)

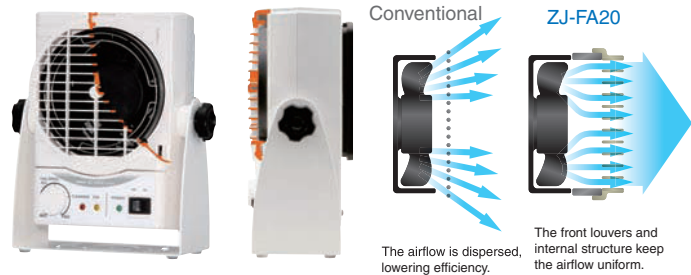

More Versatile Use

Long-term Ionization Performance

A built-in ion balance sensor constantly senses the ion condition, and a variable DC system maintains the optimal ion balance at all times. This provides a long-term, stable balance for reliable ionization.



Ion balance sensor

Variable DC System

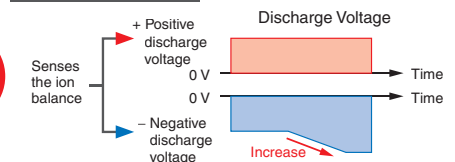

The ion balance is sensed and the voltage applied to the discharger electrodes is varied to adjust the ion output.

Clean and Easy Maintenance

The ZJ-FA20 features a fully opening front cover. Removing it allows neat and thorough cleaning, without spreading dust and other particles around. The discharger electrodes can also be replaced for long-term operation. LED lamps show the ion-generating condition and indicate when cleaning is required.



Cleaning the discharger electrodes

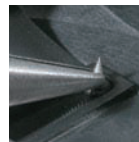

Replacing the discharger electrodes



Easy-to-see lamps

A Variety of Installation Possibilities

In addition to table-top or bench-top installation, the ZJ-FA20 can be easily mounted to an aluminum pipe. The angle can also be freely adjusted using the angle-adjustment knob and oblong stand.



Ordering Information

Ionizer

Model
ZJ-FA20

Accessories (sold separately)

Appearance	Model
Replacement Filter	ZJ9-FL120N1 (pack of 10)
Replacement Discharger Electrode	ZJ9-NDT06FN1 (pack of 6)

Ratings and Specifications

Ionizer

Item	Model	ZJ-FA20
Power supply voltage		24 VDC (See note 1.)
Current consumption		900 mA max. (input from included AC adapter)
Discharge voltage		±7 kV
Discharge method		Variable DC
Airflow (m ³ /min.)		1.4 to 2.3 m ³ /min (typical)
Ionization time (See note 2.)		1.2 s (0.8 s with no Filter)
Ion balance (See note 2.)		±10 V max.
Amount of generated ozone		0.01 ppm max. (measured at a distance of 50 mm from air outlet)
Indicators		High-voltage output lamp: ION (yellow), Cleaning lamp: CLEANING (orange), Power lamp: POWER (green)
Main functions		Automatic ion balance adjustment, airflow adjustment, manual ion balance adjustment
Ambient temperature range		Operating and storage: 0 to 50°C (with no icing or condensation)
Ambient humidity range		Operating: 35% to 65%, storage: 35% to 85% (with no condensation)
Weight (packed state)		Approx. 2.0 kg
Materials		Unit: ABS, Discharger: Tungsten, stand: SPPC
Accessories		Instruction sheet, AC adapter, warning labels (2 types), FG connection cable (2 m)

Note 1: Be sure to use the included AC adapter for ionizer operation.

Note 2: Typical default settings:

Measurement conditions: Center of air outlet at a distance of 300 mm, with maximum fan speed
 Ionization time: Time required to lower charge from ±1,000 V to ±100 V
 Ion balance measurement time: 10 s
 Plate monitor: 150 × 150 mm, 20 pF

AC Adapter (Provided: UIA336-24-JR01A-998 by UNIFIVE CO., LTD.)

Item	
Input voltage	100 to 240 VAC, 50/60 Hz
Power consumption	100 VAC: 70 VA MAX 240 VAC: 115 VA max.
Output voltage	24 VDC
Output current	1.5 A max.
Ambient temperature range	0 to 40°C
Ambient humidity range	35% to 85% (with no condensation)
Weight	Approx. 175 g (excluding power cable)
Dimensions	43.8 × 28 × 95.9 (W × D × H) mm

* If an additional AC adapter is required, please contact your OMRON sales representative

Engineering Data (Reference Value)

Airflow vs. Ionization Time

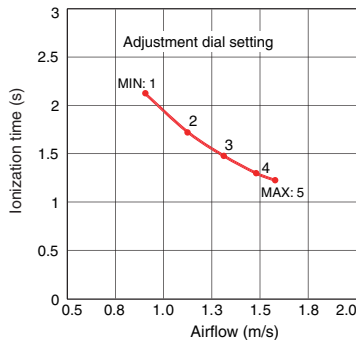

Ionization Area vs. Ionization Time

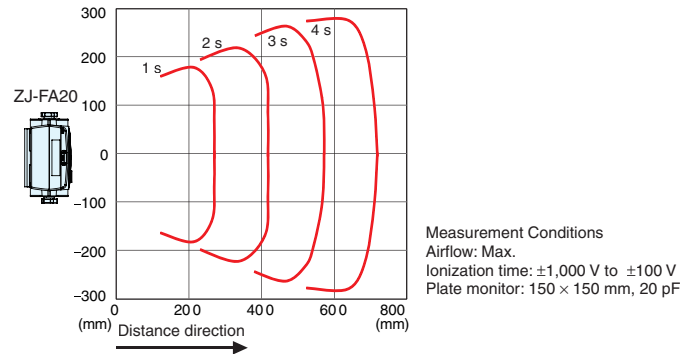

Dimensions

(Unit: mm)
 Dimensional tolerance when not specified: International tolerance grade IT16

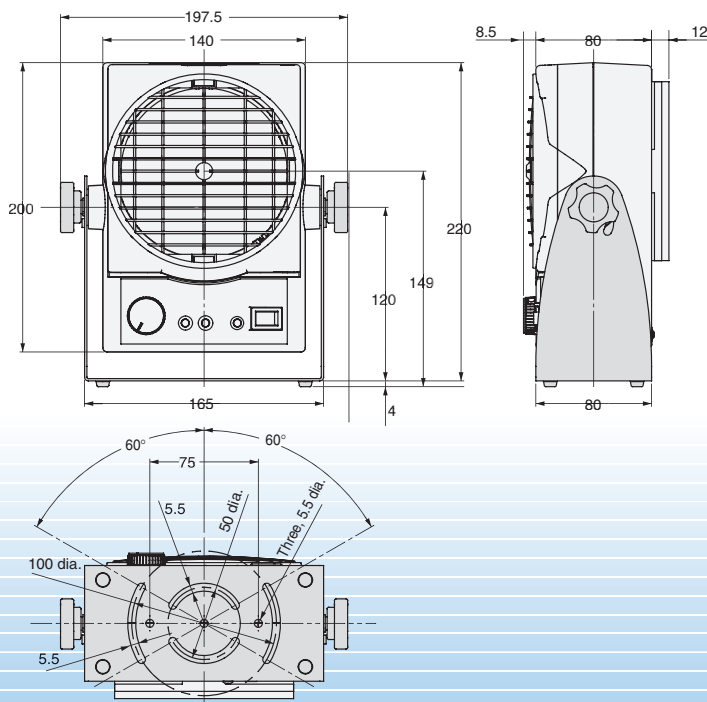

Mounting Hole Dimensions

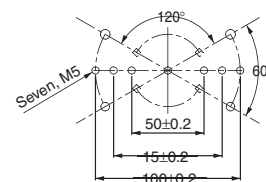

Rotation Range

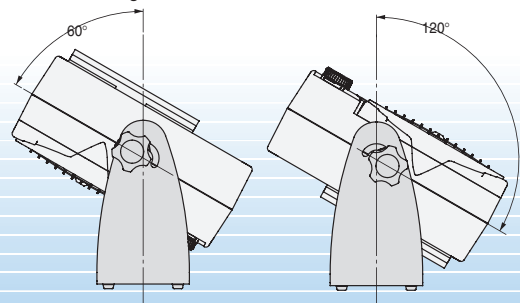

ZJ-BAS

from FACTORY

Ionizer

Digital Bar Ionizer

ZJ-BAS

The highest level of ionization in its class.



Three Technologies Supporting Effective and Efficient Ionization

Ion Sensing and Variable-AC System



An ion sensor installed on the bottom of the Ionizer detects the charge and ion balance. The applied voltage is flexibly controlled according to the ion balance conditions to raise ionization efficiency.

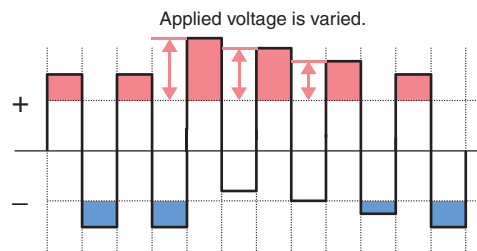

Micro Power Spraying (MPS) Structure

High-speed airflow is achieved by minimizing the air nozzle diameter. An optimal cone shape is also employed for the inside of the nozzle to further improve ion dispersion. By using a special ring guard shape to pull passive (external) air into the active air stream, the total airflow is dramatically increased.

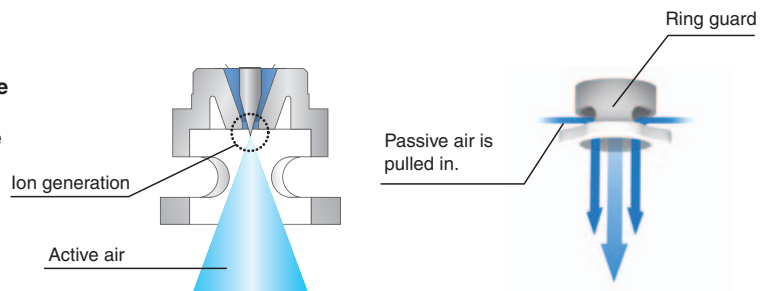

Optimized Discharge Electrode Pitch

Setting the discharge electrodes at a pitch that is 80 mm longer than in our previous models achieves an optimal layout that unifies ionizing performance and reduces ion recombination. This model ionizes over long distances with or without the use of an Air Purge Ionizer.

■ ZJ-BAS

A small amount of ion recombination.

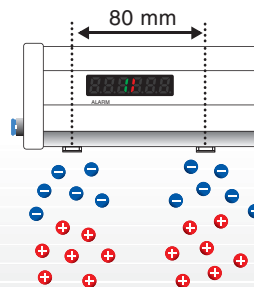

■ Previous Models

A large amount of ion recombination.

The larger pitch causes uneven ion discharge.

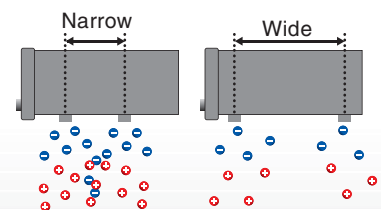

Improving Ease of Use

The Digital Ion Display Supports Safe, Reliable Settings.



From either the Remote Control or the Ionizer...

The Digital Ion Display guides you when making settings. Settings that are important for ionization performance, such as the frequency and ion balance, can be made and displayed safely and reliably from the Ionizer itself, or by using the Remote Control.



A Variety of Displays



ZJ-BAS-R01/R02 (sold separately)

Ion Balance Display

The charged state is displayed using colors. Negative ions Positive ions



When there are many negative ions



When there are many positive ions



Set Value Display

The current set value is shown on the right side of the display. The set value can be numerically confirmed, so the setting can be quantified. This allows identical settings to be made reliably and in a short time even across multiple ionizers.

Frequency setting



Ion balance adjustment



Cleaning sensitivity



Cleaning Display

Notifies when cleaning is required.



Setting Lock

Disables all operations.



Operation Stop Mode Makes Maintenance Easy

The Operation Stop Mode allows for safe cleaning and replacement work. The digital display and LED lamps tell you that the Ionizer is in Operation Stop Mode so you won't forget to return to Operation Mode when you are finished doing maintenance. Both regular operations and maintenance can be done safely and reliably.

Operation Stop Mode



The LED lamp will flash to indicate that the Ionizer is in Operation Stop Mode.

Operations from external equipment, such as stopping ionization and performing status management, can be done easily by connecting the Ionizer to a PLC using an I/O cable.



PLC

Low Running Cost

M.P.S. Construction Prolongs the Required Maintenance Period by 5 Times Compared to Our Previous Model

Greatly Reduces Maintenance Requirements

The M.P.S. nozzle emits clean air from around the discharge electrode, thus decreasing the amount of foreign matter adhesion, and dramatically extending the time before cleaning is required.

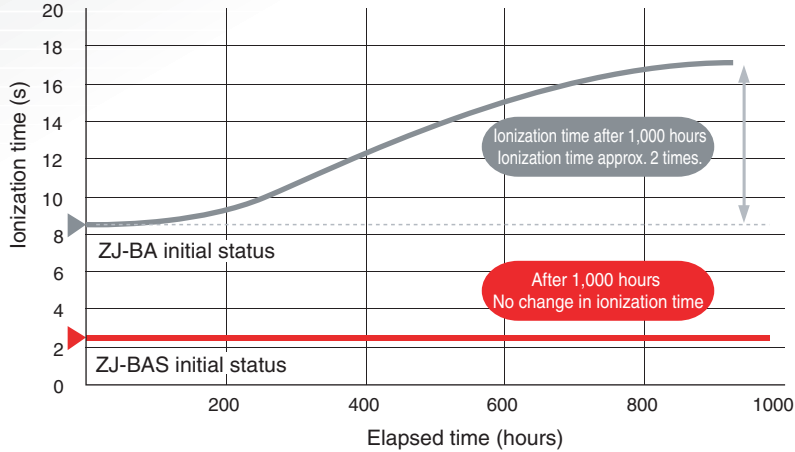

— ZJ-BA
— ZJ-BAS

Measurement conditions
 Installation distance: 1,000 mm
 Air pressure: 0.3 Mpa
 Charge plate monitor: 150 mm × 150 mm, 20 pF
 Ionization time: ±1,000 V to ±100 V

Energy-saving is a Basic Concept for OMRON Ionizers

Generally, bar-type ionizers use compressed air. Therefore, a large amount of compressed air is needed, especially for long-distance or high-speed ionization. This increases the load rate of the compressor, and consumes large amounts of electricity. The ZJ-BAS uses an optimized discharge electrode pitch and M.P.S. nozzle to improve ionization performance while using an energy-saving structure (low-current consumption) that is environmentally friendly.

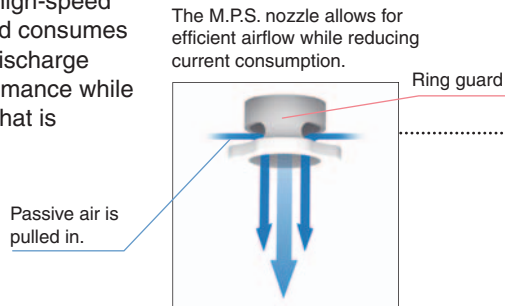

80-mm Discharge Electrode Pitch Dramatically Reduces Replacement Costs

The 80 mm discharge electrode pitch and variable-AC system reduce the number of discharge electrodes required by 60%. In addition to reducing the cleaning time, the periodic replacement of the electrodes has also been reduced, thereby dramatically reducing the running cost of the ionizer.

Effective length (mm)	Number of Discharge Modules
500	5
580	6
740	8
900	10
1,300	15
1,540	18

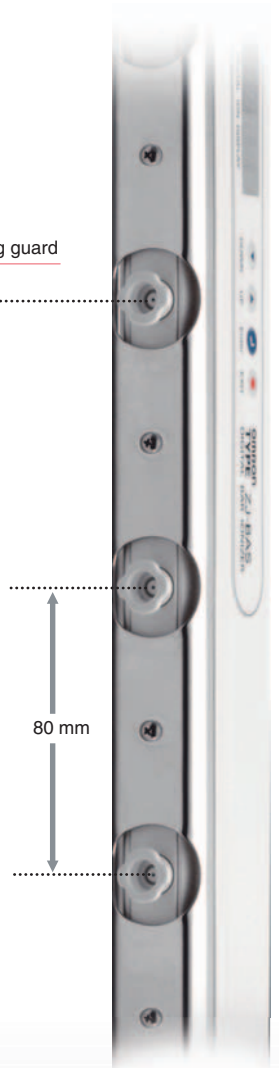

Ratings and Characteristics

Ionizer ZJ-BAS



I/O Cable ZJ-BAS-FC

Used for connecting external devices.



Power Supply Cable

Select from the two available types.

Cable with Connector on One End ZJ-BAS-MC□□A

Used when using a DC power supply.

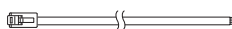

Cable with Connectors on Both Ends ZJ-BAS-MC□□B

Used when using an AC adapter.



AC Adapter ZJ-BAS-PS01



Special Remote Control

Remote Control
ZJ-BAS-R01



Remote Control Receiver
ZJ-BAS-R02

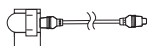

When Linking Ionizers

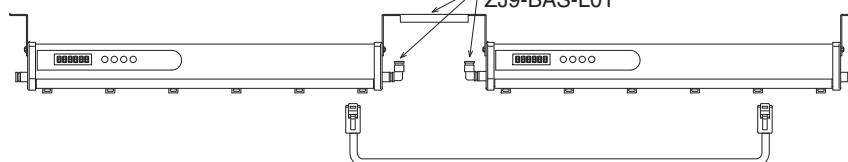

Linking Bracket Set ZJ9-BAS-L01

Power Supply Cable
ZJ-BAS-MC□□RB
(for linking Ionizers)

The length of the cables that can be linked depends on the number of ionizers to be linked together. Contact your OMRON sales representative for details.

Ordering Information

Ionizer

Appearance	Total length	Effective length	Model
	370 mm	500 mm	ZJ-BAS050
	450 mm	580 mm	ZJ-BAS058
	610 mm	740 mm	ZJ-BAS074
	770 mm	900 mm	ZJ-BAS090
	1,170 mm	1,300 mm	ZJ-BAS130
	1,410 mm	1,540 mm	ZJ-BAS154

Power Supply Cable

Appearance	Type	Cable length	Model
	Cable with Connector on One End (one ferrite core provided, 30-dia × 39 mm)	2 m	ZJ-BAS-MC02A
		5 m	ZJ-BAS-MC05A
		10 m	ZJ-BAS-MC10A
		15 m	ZJ-BAS-MC15A
		20 m	ZJ-BAS-MC20A
	Cable with Connector on Both Ends (one ferrite core provided, 30-dia × 39 mm)	2 m	ZJ-BAS-MC02B
		5 m	ZJ-BAS-MC05B
		10 m	ZJ-BAS-MC10B
		15 m	ZJ-BAS-MC15B
		20 m	ZJ-BAS-MC20B
	Used for connecting ionizers	710 mm	ZJ-BAS-MC07RB
		790 mm	ZJ-BAS-MC08RB
		950 mm	ZJ-BAS-MC09RB
		1,110 mm	ZJ-BAS-MC11RB
		1,510 mm	ZJ-BAS-MC15RB
		1,750 mm	ZJ-BAS-MC17RB

I/O Cable

Appearance	Cable length	Model
	2 m	ZJ-BAS-FC02A
	5 m	ZJ-BAS-FC05A
	10 m	ZJ-BAS-FC10A
	15 m	ZJ-BAS-FC15A
	20 m	ZJ-BAS-FC20A

Linking Bracket Set

Appearance	Contents	Model
	Linking Bracket (1) 6-dia. Elbow Air Joint (×2)	ZJ9-BAS-L01

Discharge Electrode Module

Appearance	Quantity	Model
	Set of 5	ZJ9-BAS-NT105
	Set of 10	ZJ9-BAS-NT110

Cleaning Tool

Appearance	Quantity	Model
	Pack of 20	ZJ9-BA-CT01

AC Adapter

Appearance	Specifications	Model
	Input: 100 to 240 VAC Output: 24 VDC × 2	ZJ-BAS-PS01

Special Remote Control

Appearance	Type	Model
	Remote Control	ZJ-BAS-R01
	Remote Control Receiver (Receiver, USB cable, Bracket)	ZJ-BAS-R02

Ratings and Characteristics

Ionizer

Item	Model	ZJ-BAS050	ZJ-BAS058	ZJ-BAS074	ZJ-BAS090	ZJ-BAS130	ZJ-BAS154
Ionizer length (mm)		370	450	610	770	1,170	1,410
Effective ionization length (mm) *1		500	580	740	900	1,300	1,540
Power supply voltage		24 VDC ±10%, ripple (p-p) 10% max.					
Current consumption		520 Ma max. (discharge frequency 0.08 to 0.5 Hz: 400 mA (typical), 1 to 10 Hz: 350 mA (typical), 20 to 40 Hz: 300 mA (typical))					
Discharge method		Sensing and a Variable-AC System					
Discharge voltage		6.5 k VP-P					
Discharge electrode		Tungsten electrode					
Recommended installation distance		50 to 2,000 mm					
Ion balance *2		±30 V max.					
Power supply connector		Modular type, 8-pin connector (at both ends of Unit)					
Air inlet		6-dia., one-touch coupling (at both ends of Unit)					
Maximum air pressure		0.3 MPa max.					
External I/O	Input	Discharge stop input (Turns ON at 12 to 24 VDC), input impedance: 8.2 kΩ					
	Output	Discharge stop output, cleaning output, alarm output, high-pressure error output: Signal output from photo MOS relay (100 mA max at 24 VDC)					
Display		Seven-segment LED display					
ID number		001 to 050					
Ion balance adjustment function		Yes					
Maximum number of linkable units		7 Units					
Material		Ionizer: ABS-resin, facing electrodes: Stainless steel					
Ambient temperature range		Operating: 10 to 40°C, Storage: 0 to 40°C (with no icing or condensation)					
Ambient humidity range		Operating: 35% to 65%, Storage: 35% to 85% (with no condensation)					
Weight (Ionizer only)		Approx. 0.58 kg	Approx. 0.64kg	Approx. 0.8 kg	Approx. 0.94kg	Approx. 1.28 kg	Approx. 1.5 kg
Accessories		Two mounting brackets, two M4 screws, instruction manual			Two mounting brackets, two M4 screws, 1 medium bracket, instruction manual		

*1 Measurement conditions Installation distance: 50 mm
Airflow: 1 L/min per hole
Frequency: 10 Hz
Charge plate monitor: 150 x 150 mm, 20 pF
Ionization time: (1,000 V to 100V/-1,000V to -100V): 1 s max.)

*2 Measurement conditions Installation distance: 300 mm
Airflow: 1 L/min per hole
Frequency: 10 Hz
Charge plate monitor: 150 x 150 mm, 20 pF

AC Adaptor

Item	Model	ZJ-BAS-PS01
Input voltage		100 to 240 VAC
Input current		1.2A max.
Output voltage		24 VDC
Output current		3.75A max.
Number of output ports		2 ports
Product configuration		Adaptor box, AC adaptor AC power cable
Weight (without package)		Adaptor box: Approx. 30 g AC Adapter: Approx. 475 g AC power supply cable: Approx. 260 g

Special Remote Control

Item	Model	ZJ-BAS-R01	ZJ-BAS-R02
Product configuration		Remote Control only	Receiver Cable (150 mm) Brackets (not including Remote Control)
Communications method		Infrared communications	
Number of detectable Units		50 Units	---
Power supply		Three AAA batteries	Supplied from the ZJ-BAS Ionizer
Weight (without package)		Approx. 115 g	Receiver: Approx. 5 g Cable: Approx. 6 g Bracket: Approx. 5 g
Accessories		Instruction manual	

Engineering Data (Reference Value)

Relationship of Air Pressure and Installation Distance to Ionization Time

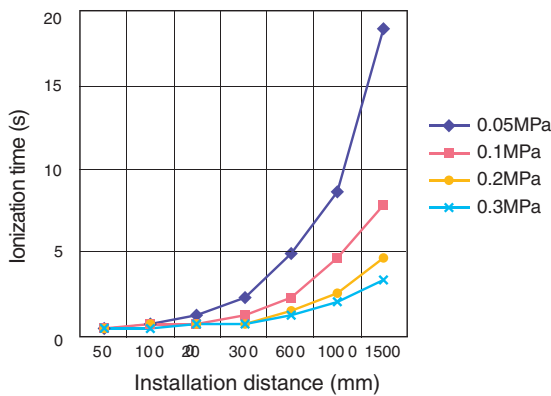

Bar Length vs. Air Pressure and Airflow

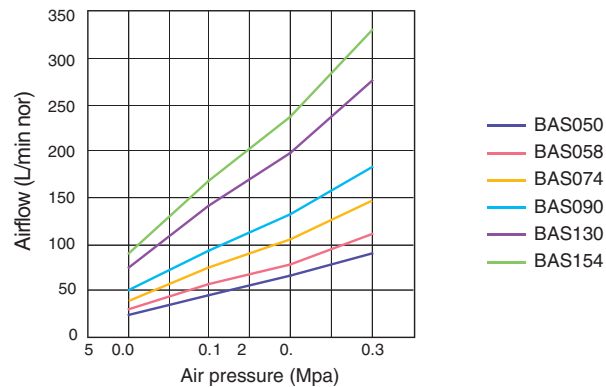

Ionization Time for Each Ionization Area

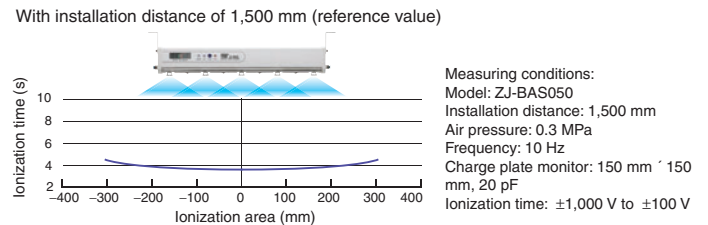
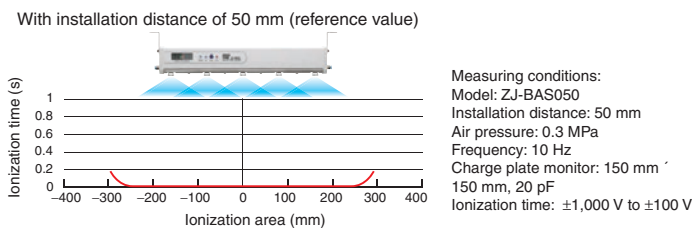

Safety Precautions

Refer to *Warranty and Limitations of Liability*.

WARNING

This product cannot be used in applications to directly or indirectly detect people for the purpose of providing safety.

Do not use this product as a sensing device to protect people.



Precaution for Correct Use

Do not use the product in ambient atmospheres or environments that exceed the ratings.

(Units: mm)

Dimensional tolerance when not specified: International tolerance grade IT16

Dimensions

Ionizer

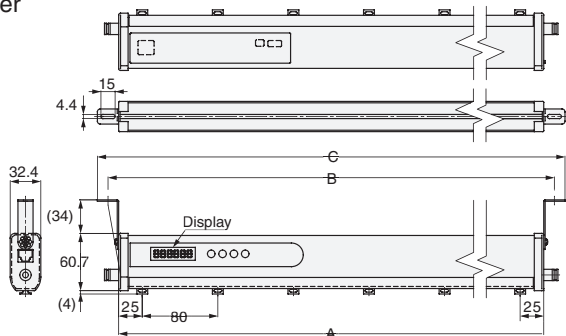

The dimensions and number of Discharge Electrode Modules for each model are shown in the following table.

Model	A (mm)	B (mm)	C (mm)	Discharge Electrode Module
ZJ-BAS050	370	394	416	5
ZJ-BAS058	450	474	496	6
ZJ-BAS074	610	634	656	8
ZJ-BAS090	770	794	816	10
ZJ-BAS130	1,170	1,194	1,216	15
ZJ-BAS154	1,410	1,434	1,456	18

Mounting bracket

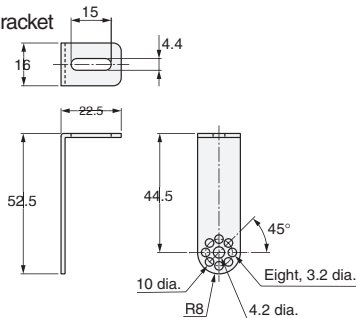

Auxiliary mounting bracket Provided with the ZJ-BAS130/BAS154

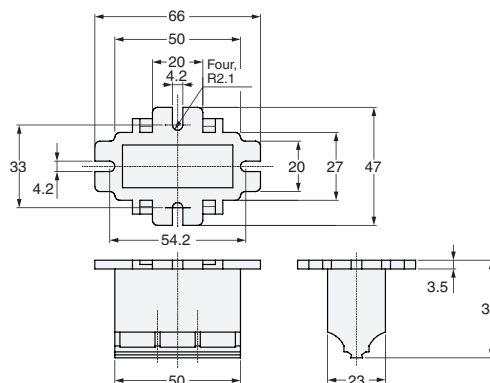

Power Supply Cable ZJ-BAS-MC□□A

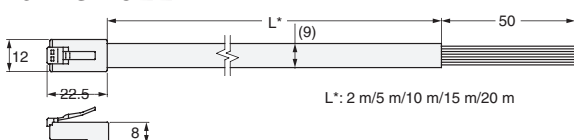

ZJ-BAS-MC□□B/MC□□RB

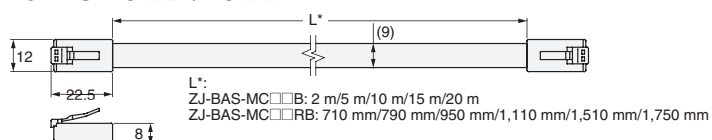

I/O Cable

ZJ-BAS-FC□□A

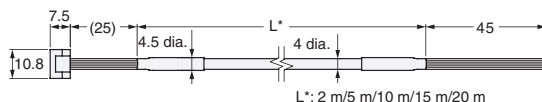

AC Adapter (Adapter box) ZJ-BAS-PS01

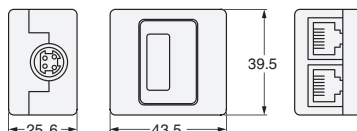

Remote Control ZJ-BAS-R01

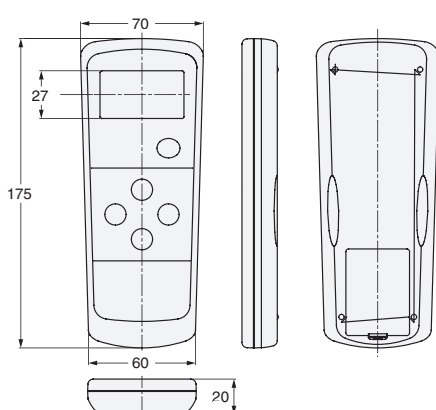

Receiver for the Remote Control (Bracket) ZJ-BAS-R02

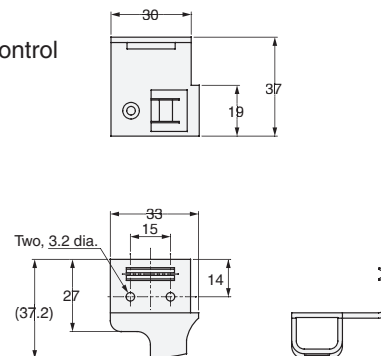

Linking Bracket ZJ-BAS-L01

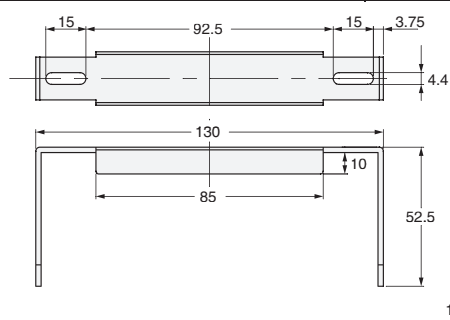

Material: Stainless steel (SUS304)

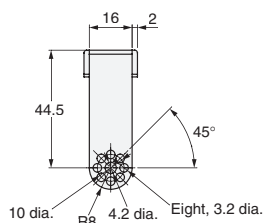

KS1

from the FACTORY

Ionizer
Air Push Type
KS1

Wide Range of Nozzles for Optimal Ionization

From pin-point to wide-area ionization, the optimal ionization for the application is now possible.



Select the Nozzle for the Application

● Standard Nozzle

- An application example of the basic standard nozzle.

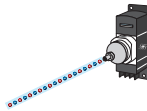

● Shower Nozzle

- Injects ionized air over an angle of 60° or 90°.

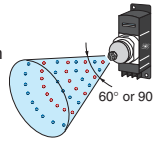

● Flat Nozzle

- Injects ionized air over an angle of 90° to enable ionization of comparatively wide objects.
- The air blow direction can be changed.

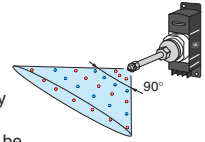

● Combination of Standard Nozzle and Optional Tube

- Attach the Optional Tube to the Standard Nozzle to blow ionized air close to the workpiece for pin-point ionization.

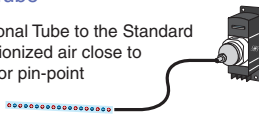

● Straight Bar Nozzle

- Neutralizes static electricity over a wide area.
- Five ionization areas from 100 to 500 mm.
- The air blow direction can be changed.

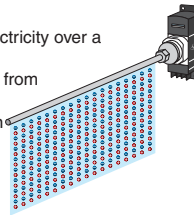

● Combination of Flexible Tube Nozzle and Optional Cap

- Combine the nozzle cap at the tip of the nozzle to enable many ionization applications.

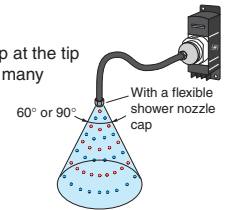

Efficient Pin-point Ionization

High-speed ionization of the target spot is possible by using a tube or metal pipe to get closer to the workpiece. The ionizer can be brought as close as 1 mm to the workpiece.

24-VDC Power Supply with No High-voltage Wiring Required

Only the 24-VDC power supply for the Ionizer is needed. No dangerous high-voltage wiring is required.

High-frequency AC Method with Excellent Ion Balance

Uses more compact high-frequency AC method with excellent ion balance and stability.

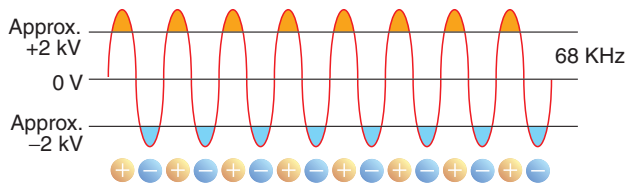

Compact Type with Built-in Controller

Controller section built in. Simple all-in-one Unit that installs easily just about anywhere.



● With standard nozzle



Safe because the high-voltage parts are covered by the nozzle.

Driven by 24-VDC power supply with no high-voltage wiring required

Product Configuration

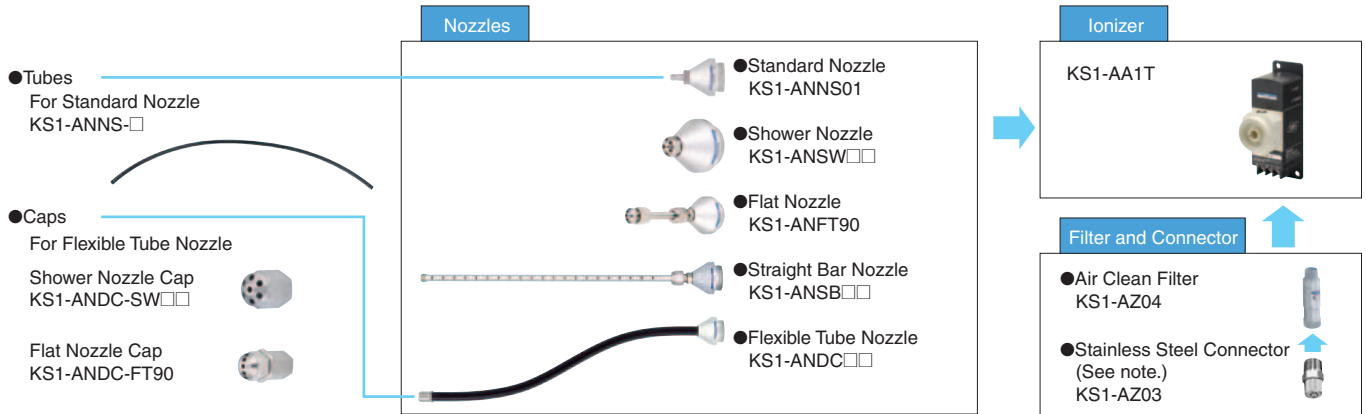

Ordering Information

Ionizer

Model
KS1-AA1T

Nozzles

Product	Model
Standard Nozzle	KS1-ANNS01
Shower Nozzle	60° KS1-ANSW60
	90° KS1-ANSW90
90° Flat Nozzle	KS1-ANFT90
Straight Bar Nozzle	100 mm KS1-ANSB10
	200 mm KS1-ANSB20
	300 mm KS1-ANSB30
	400 mm KS1-ANSB40
	500 mm KS1-ANSB50
Flexible Tube Nozzle	100 mm KS1-ANDC10
	200 mm KS1-ANDC20
	300 mm KS1-ANDC30
	400 mm KS1-ANDC40
	500 mm KS1-ANDC50

Tubes

Product	Model
500-mm Conductive Urethane Tube	KS1-ANNS-U
500-mm Fluororesin Tube	KS1-ANNS-F
500-mm Silicone Tube	KS1-ANNS-S

Caps

Product	Model
60° Flexible Shower Nozzle Cap	KS1-ANDC-SW60
90° Flexible Shower Nozzle Cap	KS1-ANDC-SW90
90° Flexible Flat Nozzle Cap	KS1-ANDC-FT90

Optional Products

Product	Model
Replacement Dischargers (set of 5)	KS1-AZ01T
Tool for Replacing Dischargers	KS1-AZ02
Stainless Steel Connector	KS1-AZ03
Air Clean Filter	KS1-AZ04

Specifications

Ionizer

Model	KS1-AA1T
Item	
Power supply voltage	24 VDC ±5%
Current consumption	Approx. 100 mA
Discharge method	High-frequency AC (Approx. 68 kHz)
Output voltage	±2 kV
Safety circuit	Outputs alarms for ionization errors
Discharge time	0.8 s max. (at a distance of 50 mm from air outlet)
Ion balance	±15 V or less (at a distance of 50 mm from air outlet)
Fluid used	Air (refer to Applicable Air)
Amount of generated ozone	0.04 ppm or less (when standard nozzle used, at a distance of 300 mm from air outlet and primary side voltage of 0.25 Mpa)
Supplied air flow	Approx. 100 L/min (ANR) (when standard nozzle used, at primary side voltage of 0.15 Mpa)
Indicators	Green POWER indicator lit while Ionizer ON, red ALM indicator lit for ionizing errors.
Air pressure range	When Standard Nozzle or Flexible Tube Nozzle is used. 0.02 to 0.25 MPa
	When Standard Nozzle Tube is attached. 0.02 to 0.12 MPa
	When Shower Nozzle, Flat Nozzle, or Straight Bar Nozzle is used. 0.05 to 0.40 MPa
Operating ambient temperature	0 to 40°C (with no condensation or icing)
Operating ambient humidity	35% to 65% (with no condensation)
Weight	235 g (ionizer only)
Accessories	One ground lead (2 m)

Air Clean Filter

Item	Model	KS1-AZ04
Fluid used		Air
Connection aperture		R(Rc)1/8
Collected particle size		0.1 μm
Collection efficiency		99.9%
Volume of air processed		40 l/min (ANR) (See note.)
Film area		29.9 cm ²
Max. voltage used		0.97 MPa
Withstanding pressure		1.47 MPa
Operating temperature range		5 to 45°C
Weight		11 g
Recommended tightening torque		400 to 600 N-cm
Unit material		Aluminum alloy (alumite treated)
Element material		Porous, hollow thread membrane

Note: At 0.7 Mpa (pressure drop of 0.03 Mpa)

Air Used

1. Make sure the pipes are adequately flushed with compressed air before connection. The pipes may become clogged or malfunctions may occur if the air in the pipes is contaminated by chips, sealing tape, rust, or other impurities.
2. Use air that does not contain oil or water. We recommend using clean dry air with a dew point of -10°C or lower and a maximum collected particle size of 0.01 μm.
3. Application is not possible if the air or the surrounding atmosphere contains organic solvents, phosphate hydraulic oil, sulfur dioxide, chlorine gas, acid or similar substance.

Engineering Data (Reference Value)

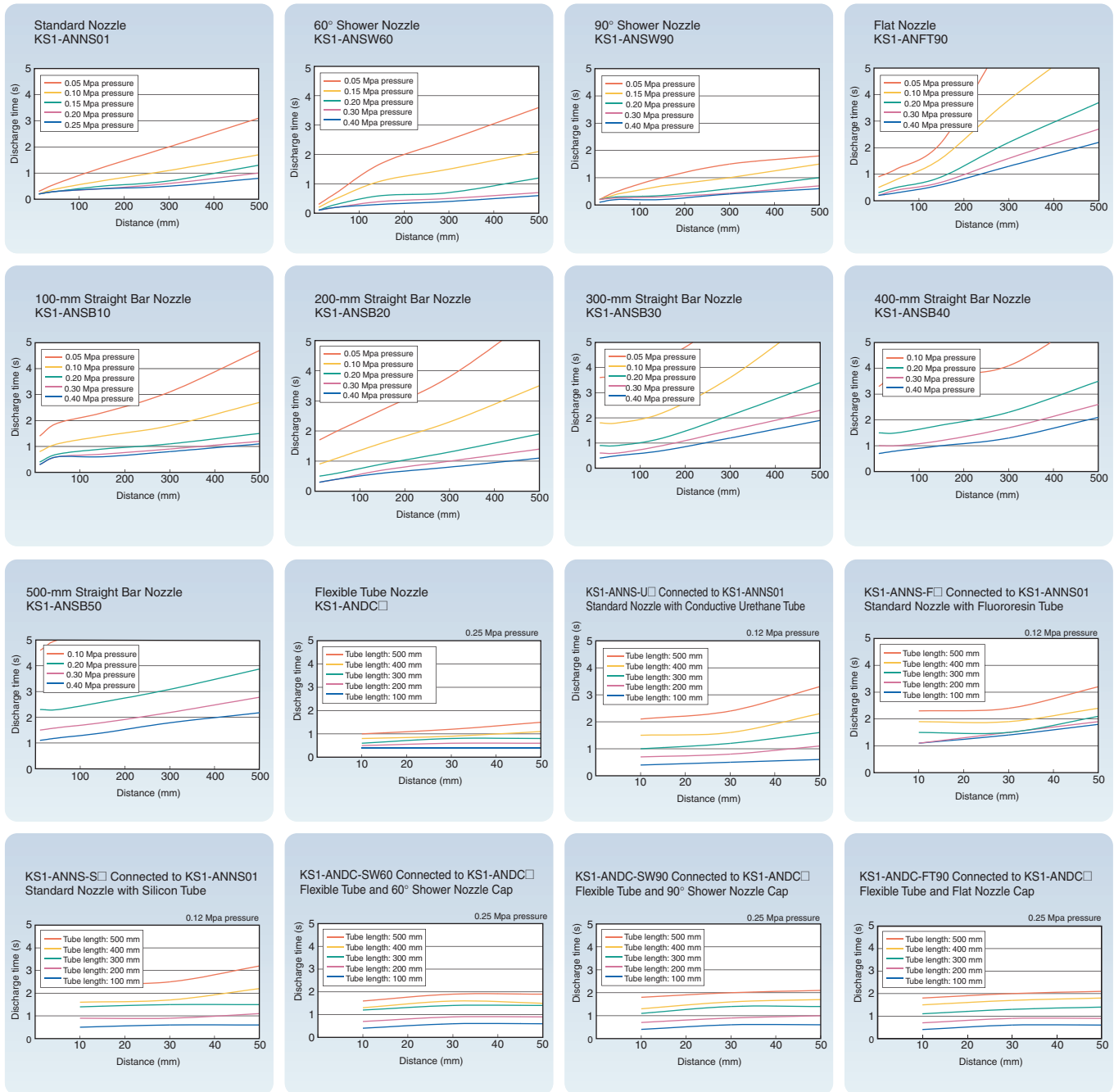

Measurement conditions
 Discharge time: Time required to lower charge from 1,000 V to 100 V
 Plate monitor: 150 × 150 mm, 20pF

Dimensions

(Unit: mm)

Ionizer

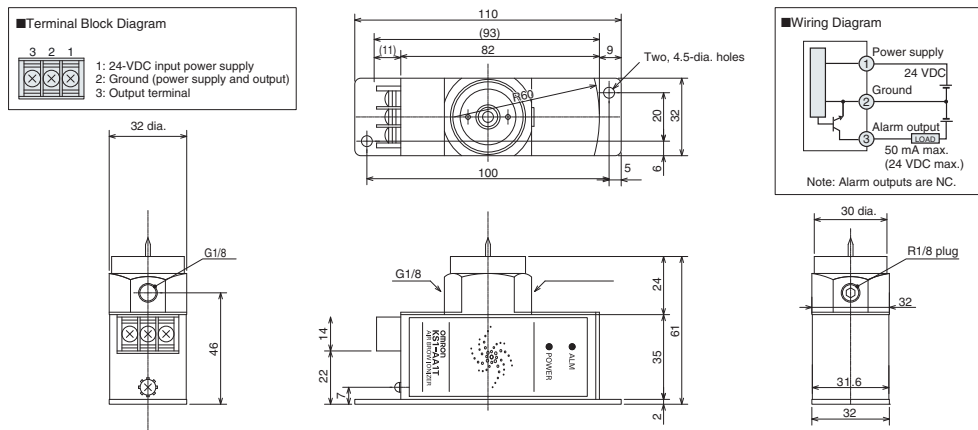

Nozzles and Optional Products Used with the Ionizer

Nozzles

Standard Nozzle

KS1-ANNS01

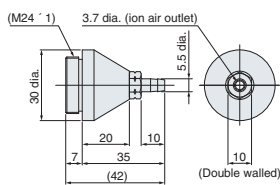

60° Shower Nozzle

KS1-ANSW60

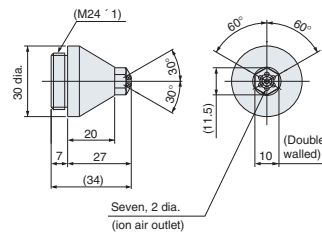

90° Shower Nozzle

KS1-ANSW90

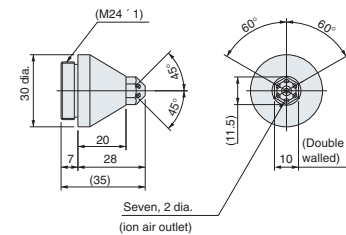

Straight Bar Nozzles

KS1-ANSB□

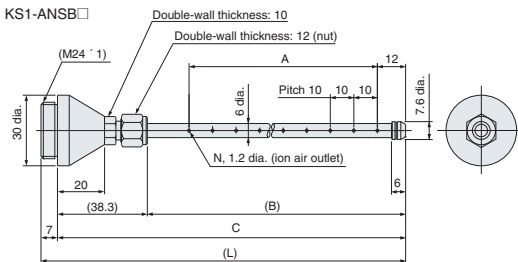

Model	A	B	C	L	N
KS1-ANSB10	100	129.7	168	175	11
KS1-ANSB20	200	229.7	268	275	21
KS1-ANSB30	300	329.7	368	375	31
KS1-ANSB40	400	429.7	468	475	41
KS1-ANSB50	500	529.7	568	575	51

Flat Nozzle

KS1-ANFT90

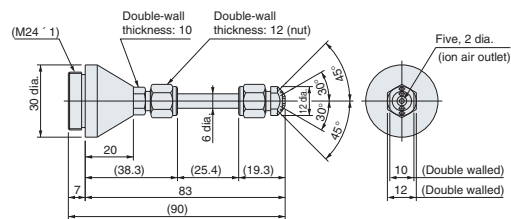

Flexible Tube Nozzles

KS1-ANDC□

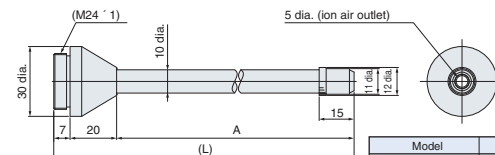

Model	A	L
KS1-ANDC10	102	129
KS1-ANDC20	202	229
KS1-ANDC30	302	329
KS1-ANDC40	402	429
KS1-ANDC50	502	529

Dimensions

Caps

Flexible Flat Nozzle Cap

KS1-ANDC-FT90

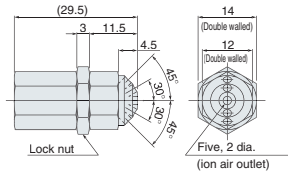

Flexible Shower Nozzle Caps

KS1-ANDC-SW□

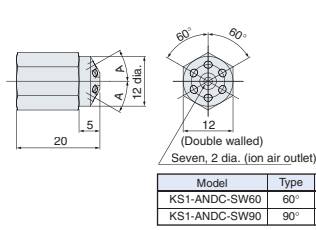

Optional Tubes

Optional Tubes for Standard Nozzles

KS1-ANNS-□

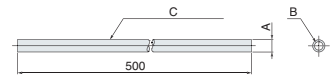

Model	A	B	C
KS1-ANNS-U	6 dia.	4 dia.	Conductive Urethane Tube
KS1-ANNS-F	7 dia.	5 dia.	Fluororesin Tube
KS1-ANNS-S	7 dia.	4 dia.	Silicon Tube

Optional Products

Optional Air Clean Filter

KS1-AZ04

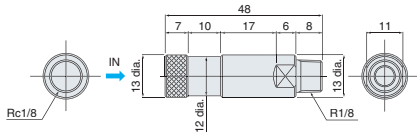

Stainless Steel Connector

KS1-AZ03

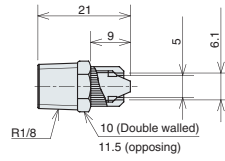

- Attached to the ionizer for air tube connection.
- If using products from other manufacturers, consider using stainless steel products for less impact on the ozone layer.

This document provides information mainly for selecting suitable models. Please read the Instruction Sheet carefully for information that the user must understand and accept before purchase, including information on warranty, limitations of liability, and precautions.

Note: Do not use this document to operate the Unit.

OMRON Corporation Industrial Automation Company
Tokyo, JAPAN

Contact: www.ia.omron.com

Regional Headquarters
OMRON EUROPE B.V.
Sensor Business Unit
Carl-Benz-Str. 4, D-71154 Nufringen, Germany
Tel: (49) 7032-811-0/Fax: (49) 7032-811-199

OMRON ASIA PACIFIC PTE. LTD.
No. 438A Alexandra Road # 05-05/08 (Lobby 2),
Alexandra Technopark,
Singapore 119967
Tel: (65) 6835-3011/Fax: (65) 6835-2711

OMRON ELECTRONICS LLC
One Commerce Drive Schaumburg,
IL 60173-5302 U.S.A.
Tel: (1) 847-843-7900/Fax: (1) 847-843-7787

OMRON (CHINA) CO., LTD.
Room 2211, Bank of China Tower,
200 Yin Cheng Zhong Road,
PuDong New Area, Shanghai, 200120, China
Tel: (86) 21-5037-2222/Fax: (86) 21-5037-2200

Authorized Distributor:

© OMRON Corporation 2009 All Rights Reserved.
In the interest of product improvement,
specifications are subject to change without notice.

CSM_6_2_0617
Cat. No. E374-E1-04

Printed in Japan
0809 (1205)