

# Panasonic®

## INSTRUCTION MANUAL

### Sensor Mounting Bracket for GX-□6 **MS-GX6-1**

CMJE-MSGX61 No.0037-21V

Thank you very much for using Panasonic products. Read this Instruction Manual carefully and thoroughly for the correct and optimum use of this product. Kindly keep this manual in a convenient place for quick reference.

## 1 MOUNTING

1. Insert the inductive proximity sensor **GX-□6** into this product as follows.
2. Push the sensor until the hook of this product catches the groove of the sensor.
3. Mount the product with a M3 pan head screw.

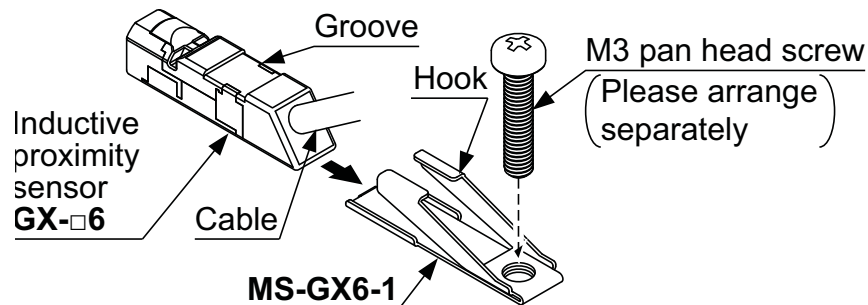

## 2 MOUNTING DIAGRAM (Unit: mm)

<When mounting front sensing type of GX-F6>

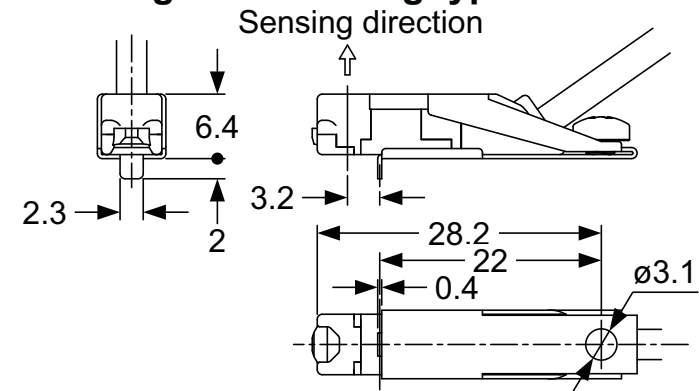

<When mounting top sensing type of GX-H6>

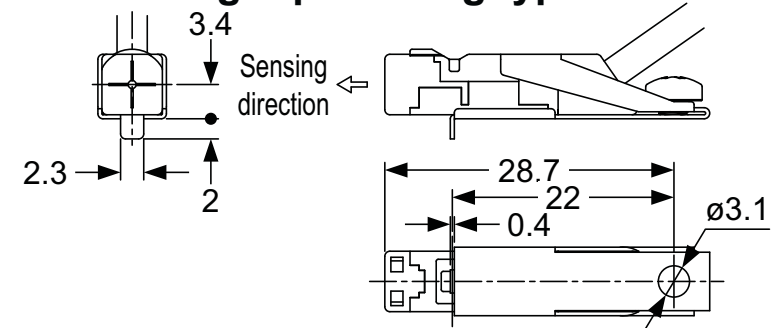

Panasonic Industrial Devices SUNX Co., Ltd.

<http://panasonic.net/id/pidsx/global>

**Overseas Sales Division (Head Office)**

2431-1 Ushiyama-cho, Kasugai-shi, Aichi, 486-0901, Japan

Phone: +81-568-33-7861 FAX: +81-568-33-8591

About our sale network, please visit our website.

© Panasonic Industrial Devices SUNX Co., Ltd. 2013

PRINTED IN JAPAN