

Robotic Automation

Industrial Robots Datasheets



The Omron's 5 benefits

The new Omron Robotic Automation enhances the most demanding manufacturing lines providing **5 main benefits**

Performance

Overall through-put is guaranteed by the synchronization of our Sysmac machine control with the new vision guided robots

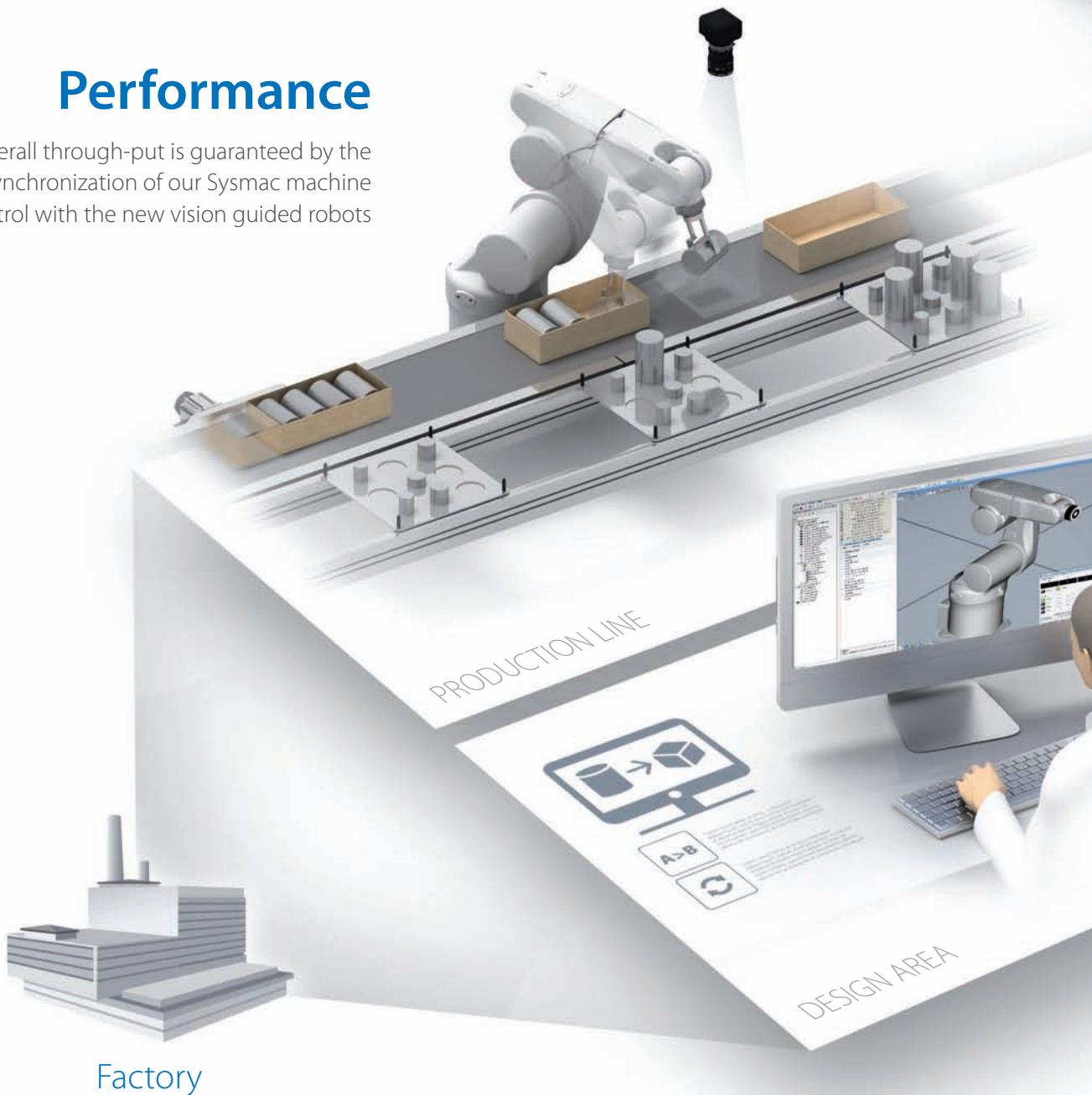

Quick Delivery

5 huge automated warehouses to provide parts in short time.

Simple

Shortening the startup and maintenance time by the integrated software environment that controls the line.

Efficient

All the production data coming from robots, controllers, sensors are collected, shared and managed to optimize the productivity.

Flexible

Software assisted system generates automatically the new programming code.



Industrial robots - 112 models in 3 categories - provide unique solutions

Manufacturing site innovation by using robots for various applications

Omron offers robotic automation solutions for applications from cutting-edge production facilities to manual operation processes by using our wide variety of control devices and integrating robotics into automation.

Parallel robots

The Hornet and Quattro are parallel robots ideal for use in the food and beverage, pharmaceutical, and healthcare industries. The Quattro that is a four-axis parallel robot with a high payload capacity achieves high speed and high precision.

Feature

The servo amplifier and controller are fully embedded into the robot, reducing wiring and saving valuable floor space



Hornet 565
Quattro 650/800



Cobra 450
eCobra 600/800
eCobra 800 Inverted



Viper 650/850

SCARA robots

High-performance four-axis SCARA robots are ideal for mechanical assembly, material handling, packaging, machine tending, and screw driving. Floor or overhead mounting models are available.

Articulated robots

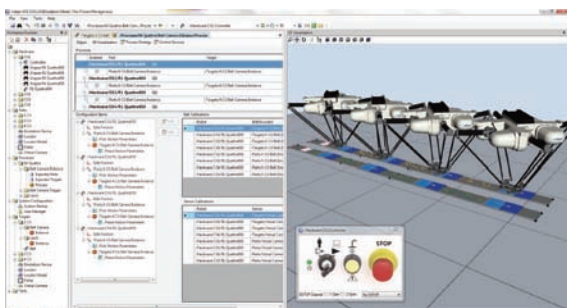

Six-axis articulated robots are ideal for mechanical assembly, material handling, packaging, and palletizing.



Automation Control Environment (ACE)





All-in-one software features a simulation function, providing an effective way to deploy applications. ACE provides a host of innovative features that allow you to increase productivity while streamlining configuration setup.

Robot Lineup

Industry			Recommended process and application	Parallel robot	
Food & Beverage	Digital	Automotive			
			Primary packing	●	●
			Secondary packing	●	●
			Aligning, packaging	●	●
			Shipping and receiving (palletizing)		
			Tightening units		
			General assembling		
			Deburring and polishing		
			Sealing		
			Measuring, inspection, testing		●
			Resin molding		
			Press operation handling		
			Machine loading		
			Sealing		
			Measuring, inspection, testing		
			Material handling		
			Mounting	Inverted	
			Payload capacity	3 kg (8 kg *1)	650: 6 kg (15 kg *2) 800: 4 kg (10 kg *2)
			Radius	565 mm	650 to 800 mm
			Reach	---	---
			Position repeatability	±0.10 mm	±0.10 mm

*1. without rotation axis

*2. Quattro using P30

SCARA robot			Articulated robot
			
Cobra 450	eCobra 600/800	eCobra 800 Inverted	Viper 650/850/ Inverted
	●	●	
	●	●	●
	●	●	●
●	●	●	●
●	●	●	●
●	●	●	●
●	●	●	●
●	●	●	●
			●
●	●	●	●
●	●	●	●
●	●	●	●
●	●	●	●
			●
Table / Floor		Inverted	Table / Floor / Inverted
5 kg	5.5 kg	5.5 kg	5 kg
---	---	---	---
450 mm	600 to 800 mm	800 mm	653 to 855 mm
±0.02 mm	±0.017 mm	±0.017 mm	±0.02 to 0.03 mm

Sysmac is a trademark or registered trademark of OMRON Corporation in Japan and other countries for OMRON factory automation products.

Intel is a trademark of Intel Corporation in the U.S. and/or other countries.

Windows is either a registered trademark or trademark of Microsoft Corporation in the United States and/or other countries.

EtherNet/IP™ is a trademark of ODVA.

Other company names and product names in this document are the trademarks or registered trademarks of their respective companies.

The product photographs and figures that are used in this catalog may vary somewhat from the actual products.

Microsoft product screen shot(s) reprinted with permission from Microsoft Corporation.

Hornet 565

Parallel robot ideal for use in the food and beverage, pharmaceutical, and healthcare industries



- Ethernet capability to control the robot through the familiar programming language (IEC 61131-3) of Machine Automation Controller NJ/NX/NY Series
- The amplifier and controller built into the robot reduces the number of cables
- Tracks up to a conveyor speed of 1.4 m/s
- Designed with a high payload to support multi-hand (multi-picking)
- Supports fast Pick & Place on a fast conveyor
- Helps reduce mounting cost and robot vibration
- Maximum working diameter 1,130 mm
- Working height 425 mm
- Maximum payload 8 kg
- Weight 52 kg

Specifications

Product name		Hornet				
Size		565				
Number of axes		3 Axis		4 Axis		
IP		Standard	IP65/67	Standard	IP65/67	
Model		1720[]-45600	1720[]-45610	1720[]-45604	1720[]-45614	
Mounting		inverted				
Working volume	X,Y axis (stroke)	1130 mm				
	Z axis (stroke)	425 mm				
	theta axis (rotation angle)	-		±360°		
Maximum Payload		8 kg		3 kg		
Repeatability		±0.10 mm				
Cycle times, sustained, 20°C ambient *1	Payload 0.1 kg	0.32 s		0.35 s		
	Payload 1.0 kg	0.34 s		0.37 s		
	Payload 3.0 kg	0.38 s		0.42 s		
Power Requirements		24 VDC: 6 A 200 to 240 VAC: 10 A, single-phase				
Protection	Base	Topside of robot	IP20	IP65	IP20	IP65
		Underside of robot	IP65			
	Platform, Arms		IP67			
Environment Requirements	Ambient Temperature		1 to 40°C			
	Humidity Range		5 to 90% (non-condensing)			
Weight		52 kg				
Basic configuration	Controller		eAIB			
	On-board I/O (Input/Output)		12/8			
	Conveyor tracking input		2			
	RS-232C serial communications port		1			
	Programming environment		ACE, PackXpert, ePLC			
	ACE Sight		Yes			
	ePLC Connect		Yes			
ePLC I/O		Yes				
Connectable controller *2		SmartController EX, NJ/NX/NY Series *3				

*1. Adept cycle, in mm (25/305/25)

*2. Choose a controller to suit your application.

*3. The robot version 2.3.C or later is required to connect with the NJ/NX/NY Series.

Dimensions

(Unit: mm)

Hornet 565

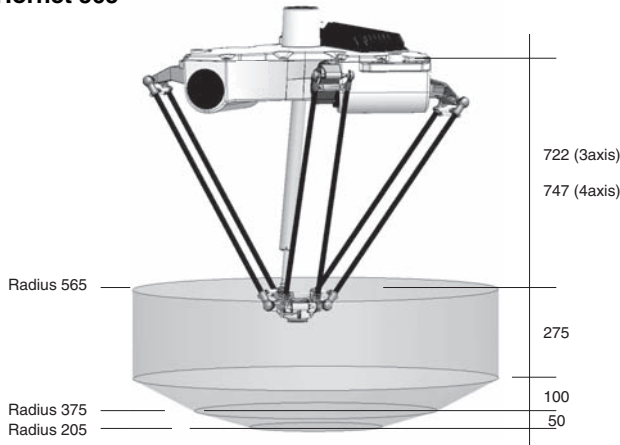

Flange

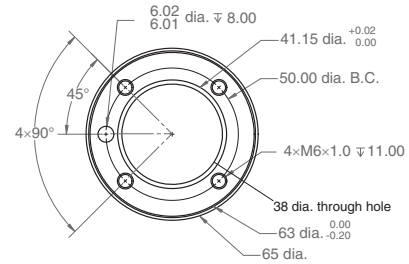

Footprint

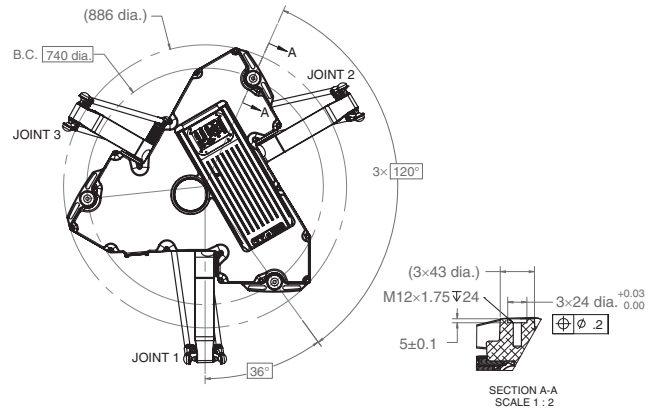

Front panel

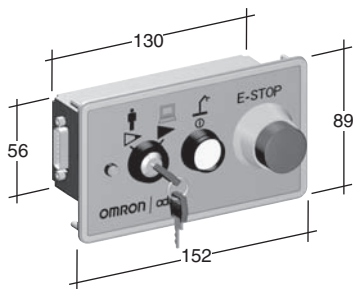

Robot Parts Code and Bundled Accessories

Type	Hornet		Hornet Add-On	
	Standard	IP65/67	Standard	IP65/67
Hornet 565 3 Axis	17201-45600	17201-45610	17203-45600	17203-45610
Hornet 565 4 Axis	17201-45604	17201-45614	17203-45604	17203-45614
Overview	Robot + eAIB with fully integrated controller		Robot + eAIB required connection cables	
Purpose	Typical for use in single robot system		Typically added to systems with an existing SmartController EX to create multi-robot systems	
Bundled Accessories	<ul style="list-style-type: none"> XSYSTEM cable with jumpers, 1.8 m/6 ft (13323-000) Front panel kit (90356-10358) 	<ul style="list-style-type: none"> XSYSTEM cable with jumpers, 1.8 m/6 ft (13323-000) Front panel kit (90356-10358) Cable Seal Kit (08765-000) 	<ul style="list-style-type: none"> XSYSTEM cable with jumpers, 1.8 m/6 ft (13323-000) XSYS cable, 4.5 m/15 ft (11585-000) DB9 splitter (00411-000) 1394 latch cable, 4.5 m/15 ft (13632-045) eV+ license to connect to controller (14529-103) 	<ul style="list-style-type: none"> XSYSTEM cable with jumpers, 1.8 m/6 ft (13323-000) XSYS cable, 4.5 m/15 ft (11585-000) DB9 splitter (00411-000) 1394 latch cable, 4.5 m/15 ft (13632-045) eV+ license to connect to controller (14529-103) Cable Seal Kit (08765-000)

Quattro 650H/HS

Four-axis parallel robot achieves high speed and high precision

- Ethernet capability to control the robot through the familiar programming language (IEC 61131-3) of Machine Automation Controller NJ/NX/NY Series
- Four-axis arm evenly distributes the load on the robot
- Fast and high-precision conveyance and assembly
- Designed with a high payload to support multi-hand (multi-picking)
- Supports fast Pick & Place on a fast conveyor
- Meets the sanitary standards of the United States Department of Agriculture for prevention of product contamination
- Maximum working diameter 1,300 mm
- Working height 500 mm
- Maximum payload 15 kg
- Weight 117 kg



Specifications

Product name		Quattro			
Size		650			
Type		H		HS	
IP		Standard	IP65/67	Standard	
Model		1721-2600[]	1721[]-2602[]	1721[]-2601[]	
Number of axes		4			
Mounting		inverted			
Working volume	X,Y axis (stroke)	1300 mm			
	Z axis (stroke)	500 mm			
	theta axis (rotation angle)	0° (fixed) (P30)			
		±46.25° (P31)			
±92.5° (P32)					
Maximum Payload		6 kg (P30: 15 kg)		3 kg (P30: 12 kg)	
Repeatability		±0.10mm			
Cycle times, sustained, at 20°C ambient	Payload 0.1 kg	0.30 s *1, 0.46 s *2		0.39 s *1, 0.55 s *2	
	Payload 1.0 kg	0.36 s *1, 0.47 s *2		0.41 s *1, 0.58 s *2	
	Payload 2.0 kg	0.37 s *1, 0.52 s *2		0.42 s *1, 0.59 s *2	
	Payload 4.0 kg	0.41 s *1, 0.58 s *2		-	
	Payload 6.0 kg	0.43 s *1, 0.61 s *2		-	
Power Requirements		24 VDC: 11 A (eAIB, SmartController) 200 to 240 VAC: 10 A, single-phase			
Protection	Base	Topside of robot	IP20	IP65	IP66
		Underside of robot	IP65	IP65	IP66
	Platform, Arms		IP67		
Environment Requirements	Ambient Temperature		1 to 40°C		
	Humidity Range		5 to 90% (non-condensing)		
Weight		117 kg			
USDA-Accepted for meat and poultry processing		---	---	Yes	
Basic configuration	Controller		SmartController EX		
	On-board I/O (Input/Output)		12/8		
	Conveyor tracking input		4		
	RS-232C serial communications port		1		
	Programming environment		ACE, PackXpert, ePLC		
	ACE Sight		Yes		
	ePLC Connect		Yes		
ePLC I/O		Yes			
Connectable controller *3		SmartController EX, NJ/NX/NY Series *4			

*1. Adept cycle, in mm (25/305/25)

*2. Extended cycle, in mm (25/700/25)

*3. Choose a controller to suit your application.

*4. The robot version 2.3.C or later is required to connect with the NJ/NX/NY Series.

Dimensions



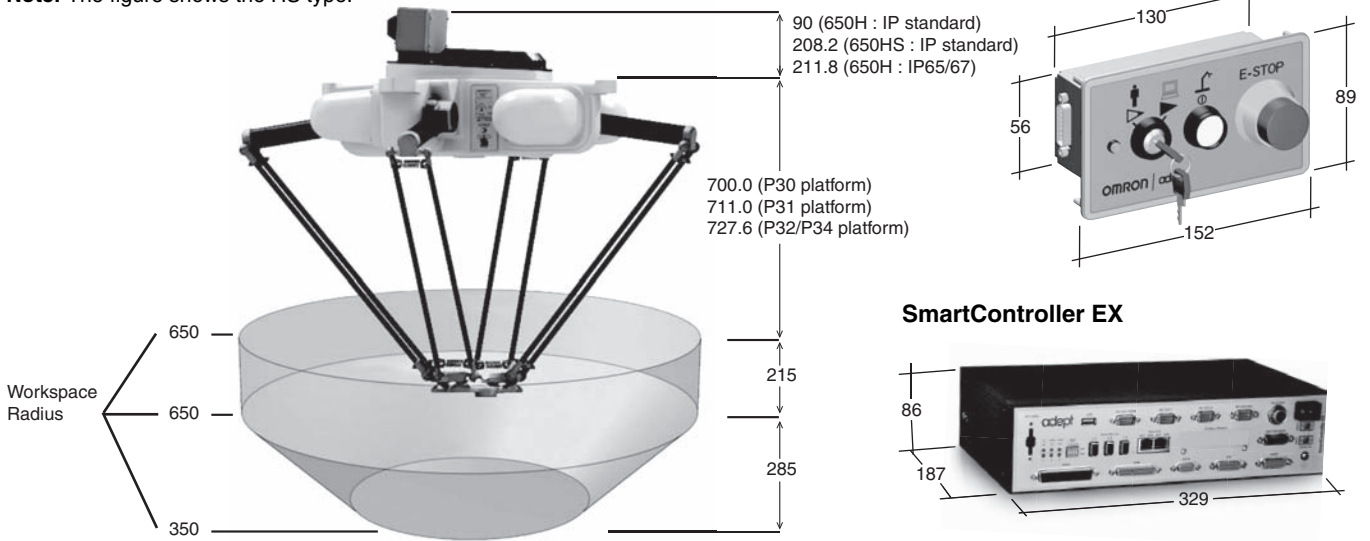

(Unit: mm)

Quattro 650H/HS

Note: The figure shows the HS type.



Four choices of platform offer different ranges of rotation.

Appearance				
Type	P30	P31	P32	P34
Rotation angle	No rotation	$\pm 46.25^\circ$	$\pm 92.5^\circ$	$\pm 185^\circ$
Maximum Payload	H: 15 kg, HS: 12 kg	H: 6 kg, HS: 3 kg	H: 6 kg, HS: 3 kg	H: 6 kg, HS: 3 kg

Note: The platform appearances of the H type are shown above. The platform of the HS type is made of stainless steel.

Robot Parts Code and Bundled Accessories

Type	Quattro with EX Controller			Quattro Add-On		
IP	Standard (H)	Standard (HS)	IP65/67	Standard (H)	Standard (HS)	IP65/67
Quattro P30	17214-26000	17214-26010	17214-26020	17213-26000	17213-26010	17213-26020
Quattro P31	17214-26001	17214-26011	17214-26021	17213-26001	17213-26011	17213-26021
Quattro P32	17214-26002	17214-26012	17214-26022	17213-26002	17213-26012	17213-26022
Quattro P34	17214-26004	17214-26014	17214-26024	17213-26004	17213-26014	17213-26024
Overview	Robot + eAIB+ SmartController EX + required connection cables			Robot + eAIB + required connection cables		
Purpose	Typical for use in single robot system and multi-robot systems.			Typically added to systems with an existing SmartController EX to create multi-robot systems		
Bundled Accessories	<ul style="list-style-type: none"> XSYSTEM cable with jumpers, 1.8 m/6 ft (13323-000) SmartController EX (09200-000) XSYS cable, 4.5 m/15 ft (11585-000) 1394 latch cable, 4.5 m/15 ft (13632-045) Front panel kit (90356-10358) eV+ license to connect to controller (14529-103) 	<ul style="list-style-type: none"> XSYSTEM cable with jumpers, 1.8 m/6 ft (13323-000) SmartController EX (09200-000) XSYS cable, 4.5 m/15 ft (11585-000) 1394 latch cable, 4.5 m/15 ft (13632-045) Front panel kit (90356-10358) eV+ license to connect to controller (14529-103) Cable Seal Kit (09564-000) 	<ul style="list-style-type: none"> XSYSTEM cable with jumpers, 1.8 m/6 ft (13323-000) SmartController EX (09200-000) XSYS cable, 4.5 m/15 ft (11585-000) 1394 latch cable, 4.5 m/15 ft (13632-045) Front panel kit (90356-10358) eV+ license to connect to controller (14529-103) Cable Seal Kit (08765-000) 	<ul style="list-style-type: none"> XSYSTEM cable with jumpers, 1.8 m/6 ft (13323-000) XSYS cable, 4.5 m/15 ft (11585-000) DB9 splitter (00411-000) 1394 latch cable, 4.5 m/15 ft (13632-045) eV+ license to connect to controller (14529-103) 	<ul style="list-style-type: none"> XSYSTEM cable with jumpers, 1.8 m/6 ft (13323-000) XSYS cable, 4.5 m/15 ft (11585-000) DB9 splitter (00411-000) 1394 latch cable, 4.5 m/15 ft (13632-045) eV+ license to connect to controller (14529-103) Cable Seal Kit (09564-000) 	<ul style="list-style-type: none"> XSYSTEM cable with jumpers, 1.8 m/6 ft (13323-000) XSYS cable, 4.5 m/15 ft (11585-000) DB9 splitter (00411-000) 1394 latch cable, 4.5 m/15 ft (13632-045) eV+ license to connect to controller (14529-103) Cable Seal Kit (08765-000)

Quattro 800H/HS

Four-axis parallel robot achieves high speed and high precision

- Ethernet capability to control the robot through the familiar programming language (IEC 61131-3) of Machine Automation Controller NJ/NX/NY Series
- Four-axis arm evenly distributes the load on the robot
- Fast and high-precision conveyance and assembly
- Designed with a high payload to support multi-hand (multi-picking)
- Supports fast Pick & Place on a fast conveyor
- Meets the sanitary standards of the United States Department of Agriculture for prevention of product contamination
- Maximum working diameter 1,600 mm
- Working height 500 mm
- Maximum payload 10 kg
- Weight 117 kg



Specifications

Product name		Quattro			
Size	Size	800			
	Type	H		HS	
	IP	Standard	IP65/67	Standard	
Model		1721[]-2630[]	1720[]-2632[]	1721[]-2631[]	
Number of axes		4			
Mounting		inverted			
Working volume	X,Y axis (stroke)	1600 mm			
	Z axis (stroke)	500 mm			
	theta axis (rotation angle)	0° (fixed) (P30)			
		±46.25° (P31)			
±92.5° (P32)					
Maximum Payload		4 kg (P30:10 kg)	1 kg (P30: 7 kg)		
Repeatability		±0.10 mm			
Cycle times, sustained (at 20°C ambient)	Payload 0.1 kg	0.33 s *1, 0.48 s *2		-	
	Payload 1.0 kg	0.38 s *1, 0.50 s *2		0.45 s *1, 0.62 s *2	
	Payload 2.0 kg	0.40 s *1, 0.55 s *2		-	
	Payload 4.0 kg	0.45 s *1, 0.62 s *2		-	
Power Requirements		24 VDC: 11 A (eAIB, SmartController) 200 to 240 VAC: 10 A, single-phase			
Protection	Base	Topside of robot	IP20	IP65	IP66
		Underside of robot	IP65	IP65	IP66
	Platform, Arms		IP67		
Environment Requirements	Ambient Temperature		1 to 40°C		
	Humidity Range		5 to 90% (non-condensing)		
USDA-Accepted for meat and poultry processing		---	---	Yes	
Weight		117 kg			
Basic configuration	Controller		SmartController EX		
	On-board I/O (Input/Output)		12/8		
	Conveyor tracking input		4		
	RS-232C serial communications port		3		
	Programming environment		ACE, PackXpert, ePLC		
	ACE Sight		Yes		
	ePLC Connect		Yes		
ePLC I/O		Yes			
Connectable controller *3		SmartController EX, NJ/NX/NY Series *4			

*1. Adept cycle, in mm (25/305/25)

*2. Extended cycle, in mm (25/700/25)

*3. Choose a controller to suit your application.

*4. The robot version 2.3.C or later is required to connect with the NJ/NX/NY Series.

Dimensions



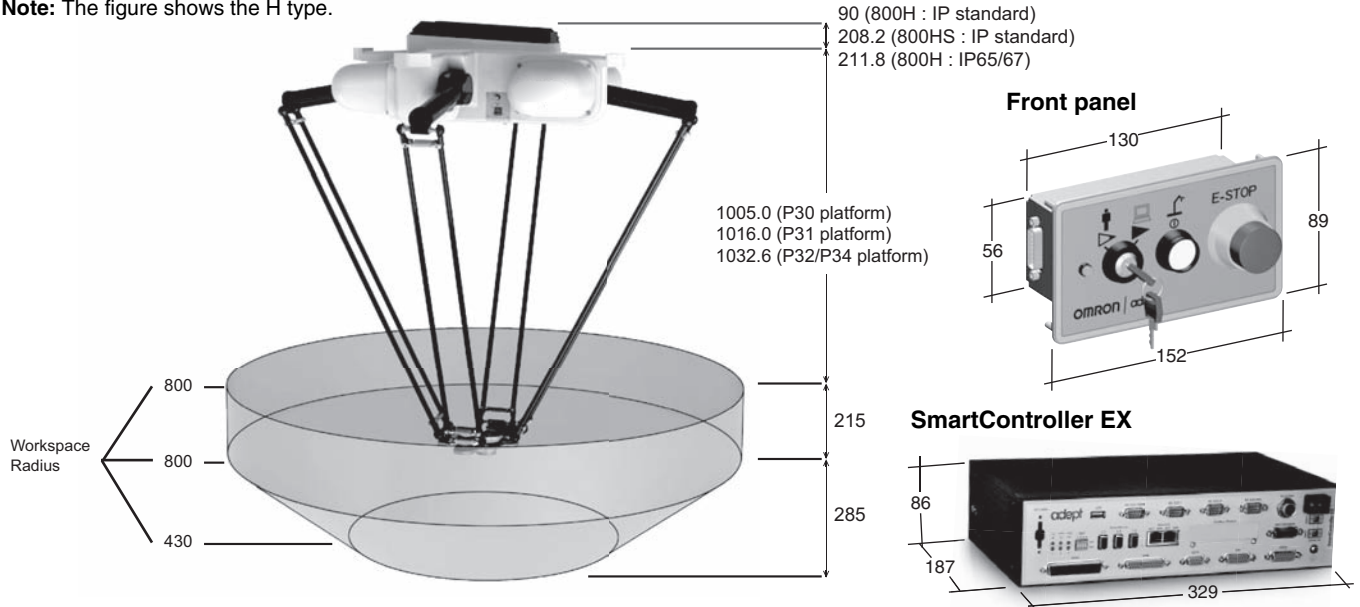

(Unit: mm)

Quattro 800H/HS

Note: The figure shows the H type.



Four choices of platform offer different ranges of rotation.

Appearance				
Type	P30	P31	P32	P34
Rotation angle	No rotation	±46.25°	± 92.5°	±185°
Maximum Payload	H: 10 kg, HS: 7 kg	H: 4 kg, HS: 1 kg	H: 4 kg, HS: 1 kg	H: 4 kg, HS: 1 kg

Note: The platform appearances of the H type are shown above. The platform of the HS type is made of stainless steel.

Robot Parts Code and Bundled Accessories

Type	Quattro with EX Controller			Quattro Add-On		
	Standard (H)	Standard (HS)	IP65/67	Standard (H)	Standard (HS)	IP65/67
Quattro P30	17214-26300	17214-26310	17214-26320	17213-26300	17213-26310	17213-26320
Quattro P31	17214-26301	17214-26311	17214-26321	17213-26301	17213-26311	17213-26321
Quattro P32	17214-26302	17214-26312	17214-26322	17213-26302	17213-26312	17213-26322
Quattro P34	17214-26304	17214-26314	17214-26324	17213-26304	17213-26314	17213-26324
Overview	Robot + eAIB+ SmartController EX + required connection cables			Robot + eAIB + required connection cables		
Purpose	Typical for use in single robot system and multi-robot systems.			Typically added to systems with an existing SmartController EX to create multi-robot systems		
Bundled Accessories	<ul style="list-style-type: none"> XSYSTEM cable with jumpers, 1.8 m/6 ft (13323-000) SmartController EX (09200-000) XSYS cable, 4.5 m/15 ft (11585-000) 1394 latch cable, 4.5 m/15 ft (13632-045) Front panel kit (90356-10358) eV+ license to connect to controller (14529-103) 	<ul style="list-style-type: none"> XSYSTEM cable with jumpers, 1.8 m/6 ft (13323-000) SmartController EX (09200-000) XSYS cable, 4.5 m/15 ft (11585-000) 1394 latch cable, 4.5 m/15 ft (13632-045) Front panel kit (90356-10358) eV+ license to connect to controller (14529-103) Cable Seal Kit (09564-000) 	<ul style="list-style-type: none"> XSYSTEM cable with jumpers, 1.8 m/6 ft (13323-000) SmartController EX (09200-000) XSYS cable, 4.5 m/15 ft (11585-000) 1394 latch cable, 4.5 m/15 ft (13632-045) Front panel kit (90356-10358) eV+ license to connect to controller (14529-103) Cable Seal Kit (08765-000) 	<ul style="list-style-type: none"> XSYSTEM cable with jumpers, 1.8 m/6 ft (13323-000) XSYS cable, 4.5 m/15 ft (11585-000) DB9 splitter (00411-000) 1394 latch cable, 4.5 m/15 ft (13632-045) eV+ license to connect to controller (14529-103) 	<ul style="list-style-type: none"> XSYSTEM cable with jumpers, 1.8 m/6 ft (13323-000) XSYS cable, 4.5 m/15 ft (11585-000) DB9 splitter (00411-000) 1394 latch cable, 4.5 m/15 ft (13632-045) eV+ license to connect to controller (14529-103) Cable Seal Kit (09564-000) 	<ul style="list-style-type: none"> XSYSTEM cable with jumpers, 1.8 m/6 ft (13323-000) XSYS cable, 4.5 m/15 ft (11585-000) DB9 splitter (00411-000) 1394 latch cable, 4.5 m/15 ft (13632-045) eV+ license to connect to controller (14529-103) Cable Seal Kit (08765-000)

Cobra 450

Mid-size SCARA robot for material handling, assembly, precision machining and adhesive application

- Ethernet capability to control the robot through the familiar programming language (IEC 61131-3) of Machine Automation Controller NJ/NX/NY Series
- Good repeatability for precision assembly
- High Payload for using tools for screw-driving and adhesive application
- Minimum footprint with separate controller
- Robot with integral power and signal cables
- Reach 450 mm
- Maximum Payload 5 kg
- Weight 30 kg



Specifications

Product name		Cobra
	Size	450
Model		1720[]-14500
Number of axes		4
Mounting		table/floor
Reach		450 mm
Maximum Payload		5 kg
Repeatability	XY	±0.02 mm
	Z	±0.01 mm
	Theta	±0.02°
Joint Range	Joint 1	±125°
	Joint 2	±145°
	Joint 3	200 mm
	Joint 4	±360°
Inertia Moment (Max.)	Joint 4	450 kg·cm ²
Joint Speeds	Joint 1	450°/s
	Joint 2	720°/s
	Joint 3	1100 mm/s
	Joint 4	1940°/s
Cycle times, *1 with 2.0 kg Payload	Burst	0.60 s
	Sustained	0.65 s
Power Requirements		24 VDC: 6 A 200 to 240 VAC: 10 A, single-phase
Protection		IP20
Clean Class		---
Environment Requirements	Ambient Temperature	5 to 40°C
	Humidity Range	35 to 90% (non-condensing)
Weight		26.95 kg
Basic configuration	Controller	eMotionBlox-40
	On-board I/O (Input/Output)	12/8
	Conveyor tracking input	2
	RS-232C serial communications port	1
	Programming environment	ACE, PackXpert, ePLC
	ACE Sight	Yes
	ePLC Connect	Yes
ePLC I/O	Yes	
Connectable controller *2		eMotionBlox-40M, SmartController EX, NJ/NX/NY Series

*1. Adept cycle, in mm 25/305/25 (seconds, at 20°C ambient)

*2. Choose a controller to suit your application.

Dimensions

(Unit: mm)

Cobra 450

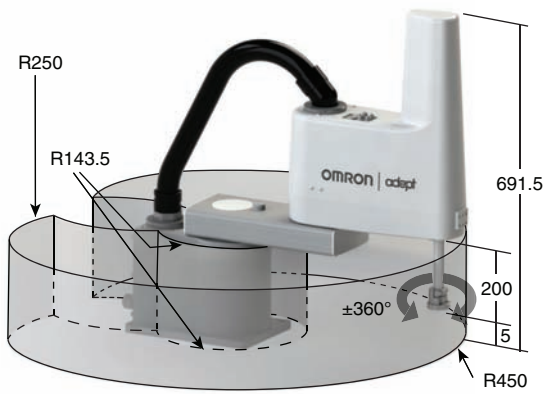

eMotionBlox-40M



Weight : 9.3 kg

Flange

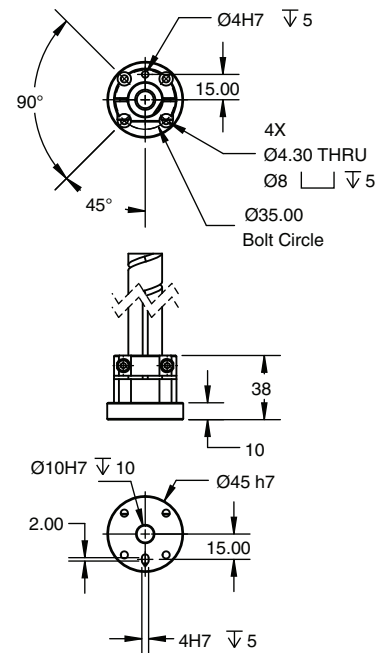

Footprint

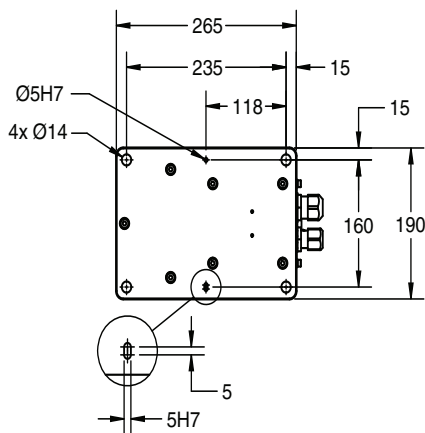

Front panel (option)

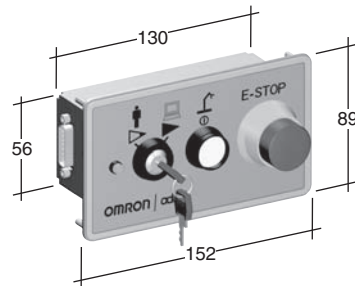

Robot Parts Code and Bundled Accessories

Type	Cobra 450	Cobra 450 Add-On
Cobra 450	17201-14500	17203-14500
Overview	Robot + Integral Power and Signal Cables + eMotionBlox-40M amplifier with fully-integrated controls	Robot + Integral Power and Signal Cables + eMotionBlox-40M amplifier + required connection cables
Purpose	Typical for use in single-robot system	Typically added to systems with an existing SmartController EX to create multi-robot systems
Bundled Cable/Accessories	<ul style="list-style-type: none"> XSYSTEM cable with jumpers, 1.8 m/6 ft (13323-000) 	<ul style="list-style-type: none"> XSYSTEM cable with jumpers, 1.8 m/6 ft (13323-000) XSYS cable, 4.5 m/15 ft (11585-000) DB9 splitter (00411-000) 1394 latch cable, 4.5 m/15 ft (13632-045) eV+ license to connect to controller (14529-103)

eCobra 600 Lite/Standard/Pro

Mid-size SCARA robot for precision machining, assembly, and material handling

- Ethernet capability to control the robot through the familiar programming language (IEC 61131-3) of Machine Automation Controller NJ/NX/NY Series
- High repeatability suitable for material handling and precision assembly
- High payload for screw-driving tools
- Amplifier and controller built into the robot reduces the number of cables
- Choose the right robot for you application from three different types
- Reach 600 mm
- Maximum payload 5.5 kg
- Weight 41 kg

Specifications

Product name		eCobra					
		Size		600			
		Type	600 Lite		600 Standard		600 Pro
	Cleanroom	Standard	Cleanroom	Standard	Cleanroom	Standard	Cleanroom
Model		17010-16000	17010-16010	1711[]-16000	1711[]-16010	1721[]-16000	1721[]-16010
Number of axes		4					
Mounting		table/floor					
Reach		600 mm					
Maximum Payload		5.5 kg					
Repeatability	XY	±0.017 mm					
	Z	±0.003 mm					
	Theta	±0.019°					
Joint Range	Joint 1	±105°					
	Joint 2	±157.5°					
	Joint 3	210 mm					
	Joint 4	±360°					
Inertia Moment (Max.)	Joint 4	450 kg-cm ²					
Joint Speeds	Joint 1	386°/s					
	Joint 2	720°/s					
	Joint 3	1100 mm/s					
	Joint 4	1200°/s					
Cycle times *1 (Payload 2.0 kg)	Burst	0.66 s		0.55 s		0.39 s	
	Sustained	0.66 s		0.55 s		0.45 s	
Power Requirements		24 VDC: 6 A 200 to 240 VAC: 10 A, single-phase					
Protection		IP20					
Clean Class		---	Class 10	---	Class 10	---	Class 10
Environment Requirements	Ambient Temperature	5 to 40°C					
	Humidity Range	5 to 90% (non-condensing)					
Weight		41 kg					
Basic configuration	Controller	eAIB					
	On-board I/O (Input/Output)	12/8, 4 Solenoid Output					
	Conveyor tracking input	No				2	
	RS-232C serial communications port	No		1			
	Programming environment	ACE		ACE, PackXpert, ePLC			
	ACE Sight	No *2		Yes			
	ePLC Connect	No		Yes			
	ePLC I/O	No		Yes			
Connectable controller *3		No		SmartController EX, NJ/NX/NY Series *4			

*1. Adept cycle, in mm 25/305/25 (seconds, at 20°C ambient)

*2. The SmartVision MX cannot be used with the Lite type.

*3. Choose a controller to suit your application.

*4. The robot version 2.3.C or later is required to connect with the NJ/NX/NY Series.

Dimensions

(Unit: mm)

eCobra 600

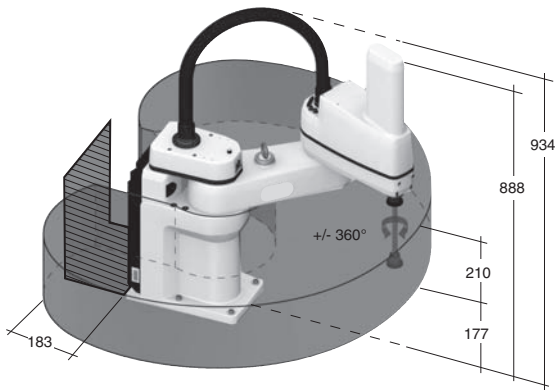

- Work Envelope: Radius 600 mm
- Inner Limit: Radius 163 mm
- Height: 210 mm
- Required clearance to open eAIB Chassis

Flange

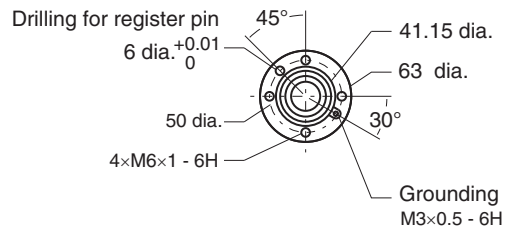

Footprint

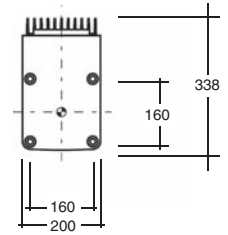

Front panel



Robot Parts Code and Bundled Accessories

Type	eCobra		eCobra Add-On		
	Cleanroom	Standard	Cleanroom	Standard	Cleanroom
eCobra 600 Lite	17010-16000	17010-16010	---	---	---
eCobra 600 Standard	17111-16000	17111-16010	17113-16000	17113-16010	17113-16010
eCobra 600 Pro	17211-16000	17211-16010	17213-16000	17213-16010	17213-16010
Overview	Robot + eAIB with fully integrated controls		Robot + eAIB with required connection cables		
Purpose	Typical for use in single robot system		Typically added to systems with an existing SmartController EX to create multi-robot systems		
Bundled Accessories	<ul style="list-style-type: none"> • XSYSTEM cable with jumpers, 1.8 m/6 ft (13323-000) • Front panel kit (90356-10358) 		<ul style="list-style-type: none"> • XSYSTEM cable with jumpers, 1.8 m/6 ft (13323-000) • XSYS cable, 4.5 m/15 ft (11585-000) • DB9 splitter (00411-000) • 1394 latch cable, 4.5 m/15 ft (13632-045) • eV+ license to connect to controller (14529-103) 		

eCobra 800 Lite/Standard/Pro

Large SCARA robot for precision machining, assembly, and material handling

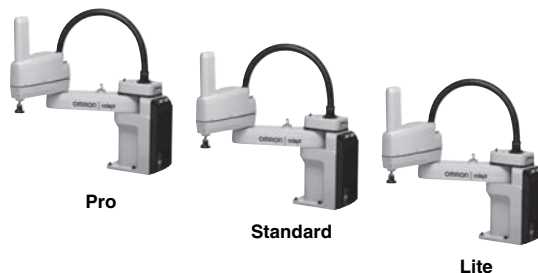

- Ethernet capability to control the robot through the familiar programming language (IEC 61131-3) of Machine Automation Controller NJ/NX/NY Series
- Reach is extended to 800 mm without compromising repeatability
- High payload for screw-driving tools
- The amplifier and controller built into the robot reduces the number of cables
- Choose the right robot for you application from three different types
- Reach 800 mm
- Maximum payload 5.5 kg
- Weight 43 kg

Specifications

Product name		eCobra								
		800								
		800 Lite			800 Standard			800 Pro		
Size		Standard	Cleanroom	IP65	Standard	Cleanroom	IP65	Standard	Cleanroom	IP65
Type										
Cleanroom/IP										
Model		17010-18000	17010-18010	17010-18030	1711[]-18000	1711[]-18010	1711[]-18030	1721[]-18000	1721[]-18010	1721[]-18030
Number of axes		4								
Mounting		table/floor								
Reach		800 mm								
Maximum Payload		5.5 kg								
Repeatability	XY	±0.017 mm								
	Z	±0.003 mm								
	Theta	±0.019°								
Joint Range	Joint 1	±105°								
	Joint 2	±157.5°								
	Joint 3	210 mm								
	Joint 4	±360°								
Inertia Moment (Max.)	Joint 4	450 kg-cm ²								
Joint Speeds	Joint 1	386°/s								
	Joint 2	720°/s								
	Joint 3	1100 mm/s								
	Joint 4	1200°/s								
Cycle times (Payload 2.0 kg)	Burst *1	0.73 s			0.62 s			0.44 s		
	Sustained *1	0.73 s			0.62 s			0.54 s		
Power Requirements		24 VDC: 6 A 200 to 240 VAC: 10 A, single-phase								
Protection		IP20	IP20	IP65	IP20	IP20	IP65	IP20	IP20	IP65
Clean Class		---	Class 10	---	---	Class 10	---	---	Class 10	---
Environment Requirements	Ambient Temperature	5 to 40°C								
	Humidity Range	5 to 90% (non-condensing)								
Weight		43 kg								
Basic configuration	Controller	eAIB								
	On-board I/O (Input/Output)	12/8, 4 Solenoid Output								
	Conveyor tracking input	No						2		
	RS-232C serial communications port	No			1					
	Programming environment	ACE			ACE, PackXpert, ePLC					
	ACE Sight	No *2			Yes					
	ePLC Connect	No			Yes					
ePLC I/O	No			Yes						
Connectable controller *3		No			SmartController EX, NJ/NX/NY Series *4					

*1. Adept cycle, in mm 25/305/25 (seconds, at 20°C ambient)

*2. The SmartVision MX cannot be used with the Lite type.

*3. Choose a controller to suit your application.

*4. The robot version 2.3.C or later is required to connect with the NJ/NX/NY Series.

Dimensions

(Unit: mm)

eCobra 800

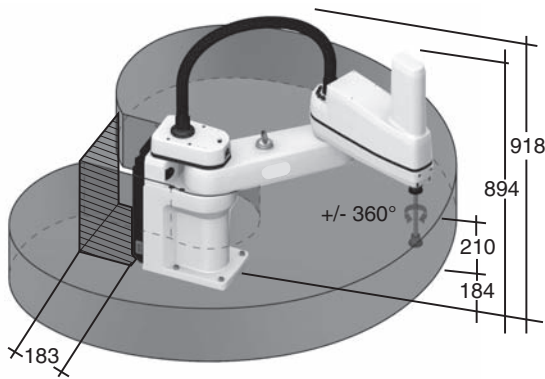

- Work Envelope: Radius 800 mm
Inner Limit: Radius 164 mm
Height: 210 mm
- Required clearance to open eAIB Chassis

Flange

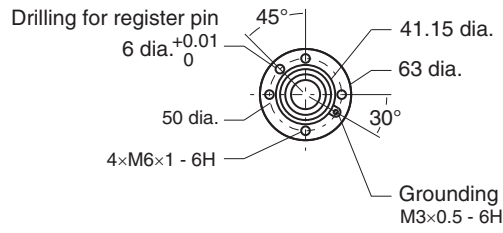

Footprint

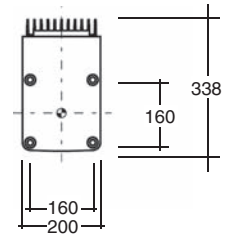

Front panel

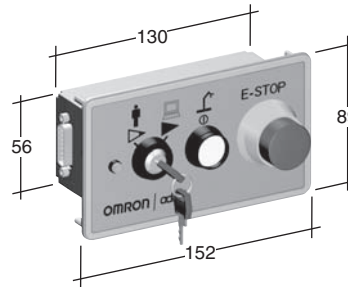

Robot Parts Code and Bundled Accessories

Type	eCobra			eCobra Add-On			
	Cleanroom/IP	Standard	Cleanroom	IP65	Standard	Cleanroom	IP65
eCobra 800 Lite	17010-18000	17010-18010	17010-18030	---	---	---	---
eCobra 800 Standard	17111-18000	17111-18010	17111-18030	17113-18000	17113-18010	17113-18030	17113-18030
eCobra 800 Pro	17211-18000	17211-18010	17211-18030	17213-18000	17213-18010	17213-18030	17213-18030
Overview	Robot + eAIB with fully integrated controls			Robot + eAIB with required connection cables			
Purpose	Typical for use in single robot system			Typically added to systems with an existing SmartController EX to create multi-robot systems			
Bundled Accessories	<ul style="list-style-type: none"> • XSYSTEM cable with jumpers, 1.8 m/6 ft (13323-000) • Front panel kit (90356-10358) 		<ul style="list-style-type: none"> • XSYSTEM cable with jumpers, 1.8 m/6 ft (13323-000) • Front panel kit (90356-10358) • Cable Seal Kit (04813-000) 	<ul style="list-style-type: none"> • XSYSTEM cable with jumpers, 1.8 m/6 ft (13323-000) • XSYS cable, 4.5 m/15 ft (11585-000) • DB9 splitter (00411-000) • 1394 latch cable, 4.5 m/15 ft (13632-045) • eV+ license to connect to controller (14529-103) 	<ul style="list-style-type: none"> • XSYSTEM cable with jumpers, 1.8 m/6 ft (13323-000) • XSYS cable, 4.5 m/15 ft (11585-000) • DB9 splitter (00411-000) • 1394 latch cable, 4.5 m/15 ft (13632-045) • eV+ license to connect to controller (14529-103) • Cable Seal Kit (04813-000) 		

eCobra 800 Inverted Lite/Standard/Pro

Overhead-mount large SCARA robot for precision machining, assembly, and material handling

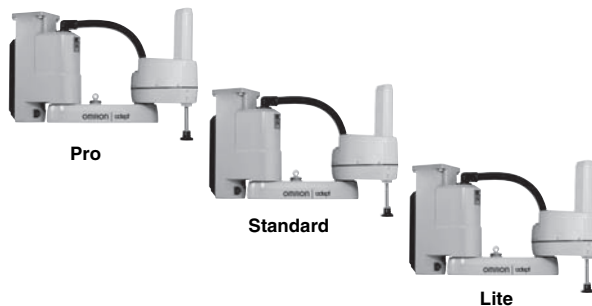

- Ethernet capability to control the robot through the familiar programming language (IEC 61131-3) of Machine Automation Controller NJ/NX/NY Series
- Overhead-mounting configuration for efficient use of space
- High payload for screw-driving tools
- The amplifier and controller built into the robot reduces the number of cables
- Choose the right robot for you application from three different types
- Reach 800 mm
- Maximum payload 5.5 kg
- Weight 51 kg

Specifications

Product name		eCobra Inverted								
		800								
		800 Lite			800 Standard			800 Pro		
Type		Standard	Cleanroom	IP65	Standard	Cleanroom	IP65	Standard	Cleanroom	IP65
Cleanroom/IP										
Model		17010-18400	17010-18410	17010-18430	1711[]-18400	1711[]-18410	1711[]-18430	1721[]-18400	1721[]-18410	1721[]-18430
Number of axes		4								
Mounting		inverted								
Reach		800 mm								
Maximum Payload		5.5 kg								
Repeatability	XY	±0.017 mm								
	Z	±0.003 mm								
	Theta	±0.019°								
Joint Range	Joint 1	±123.5°								
	Joint 2	±156.5°								
	Joint 3	210 mm								
	Joint 4	±360°								
Inertia Moment (Max.)	Joint 4	450 kg·cm ²								
Joint Speeds	Joint 1	386°/s								
	Joint 2	720°/s								
	Joint 3	1100 mm/s								
	Joint 4	1200°/s								
Power Requirements		24 VDC: 6 A 230 VAC: 10 A								
Protection		IP20	IP20	IP65	IP20	IP20	IP65	IP20	IP20	IP65
Clean Class		---	Class 10	---	---	Class 10	---	---	Class 10	---
Environment Requirements	Ambient Temperature	5 to 40°C								
	Humidity Range	5 to 90% (non-condensing)								
Weight		51 kg								
Basic configuration	Controller	eAIB								
	On-board I/O (Input/Output)	12/8, 4 Solenoid Output								
	Conveyor tracking input	No						2		
	RS-232C serial communications port	No						1		
	Programming environment	ACE						ACE, PackXpert, ePLC		
	ACE Sight	No *1						Yes		
	ePLC Connect	No						Yes		
ePLC I/O	No						Yes			
Connectable controller *2		No						SmartController EX, NJ/NX/NY Series *3		

*1. The SmartVision MX cannot be used with the Lite type.
 *2. Choose a controller to suit your application.
 *3. The robot version 2.3.C or later is required to connect with the NJ/NX/NY Series.

Dimensions

(Unit: mm)

eCobra Inverted 800

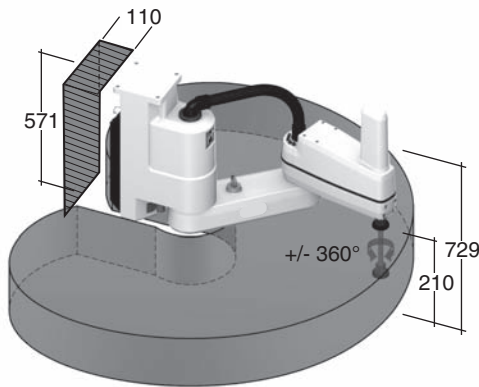

- Work Envelope: Radius 800 mm
Inner Limit: Radius 167 mm
Height: 210 mm
- Required clearance to open eAIB Chassis

Flange

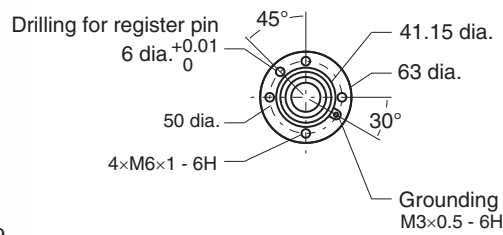

Footprint

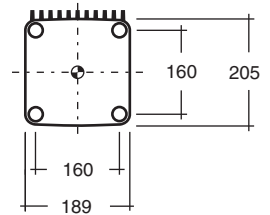

Front panel



Robot Parts Code and Bundled Accessories

Type	eCobra			eCobra Add-On			
	Cleanroom/IP	Standard	Cleanroom	IP65	Standard	Cleanroom	IP65
eCobra 800 Inverted Lite	17010-18400	17010-18410	17010-18430	---	---	---	---
eCobra 800 Inverted Standard	17111-18400	17111-18410	17111-18430	17113-18400	17113-18410	17113-18430	17113-18430
eCobra 800 Inverted Pro	17211-18400	17211-18410	17211-18430	17213-18400	17213-18410	17213-18430	17213-18430
Overview	Robot + eAIB with fully integrated controls			Robot + eAIB with required connection cables			
Purpose	Typical for use in single robot system			Typically added to systems with an existing SmartController EX to create multi-robot systems			
Bundled Accessories	<ul style="list-style-type: none"> • XSYSTEM cable with jumpers, 1.8 m/6 ft (13323-000) • Front panel kit (90356-10358) 		<ul style="list-style-type: none"> • XSYSTEM cable with jumpers, 1.8 m/6 ft (13323-000) • Front panel kit (90356-10358) • Cable Seal Kit (09073-000) 	<ul style="list-style-type: none"> • XSYSTEM cable with jumpers, 1.8 m/6 ft (13323-000) • XSYS cable, 4.5 m/15 ft (11585-000) • DB9 splitter (00411-000) • 1394 latch cable, 4.5 m/15 ft (13632-045) • eV+ license to connect to controller (14529-103) 			

Articulated Robots

Viper 650

Articulated robot for machining, assembly, and material handling

- Ethernet capability to control the robot through the familiar programming language (IEC 61131-3) of Machine Automation Controller NJ/NX/NY Series
- Diagnostics display enables faster trouble shooting
- High-resolution, absolute encoders to provide high accuracy, superior slow-speed following, and easy calibration
- High-efficiency, low-inertia Harmonic Drives and a lightweight arm to deliver maximum acceleration
- Reach 653 mm
- Maximum payload 5 kg
- Weight 34 kg

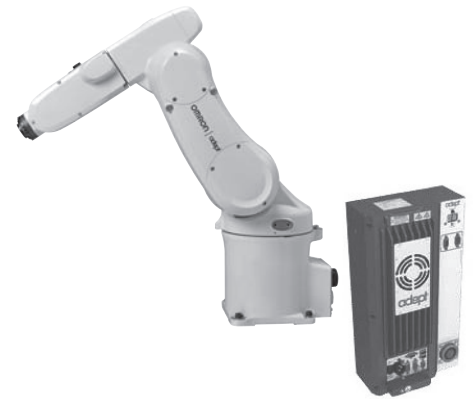

Specifications

Product name	Viper			
	Size	650		
	Cleanroom/IP	Standard	Cleanroom	IP54/65
Model		1720[]-36000	1720[]-36020	1720[]-36010
Mounting	Table/Floor/Inverted			
Number of axes	6			
Reach	653 mm			
Maximum Payload	5 kg			
Repeatability	XYZ	±0.02 mm		
Joint Range	Joint 1	±170°		
	Joint 2	-190°, +45°		
	Joint 3	-29°, +256°		
	Joint 4	±190°		
	Joint 5	±120°		
	Joint 6	±360°		
Inertia Moment (Max.)	Joint 4	0.295 kgm ²		
	Joint 5	0.295 kgm ²		
	Joint 6	0.045 kgm ²		
Joint Speeds	Joint 1	328°/s		
	Joint 2	300°/s		
	Joint 3	375°/s		
	Joint 4	375°/s		
	Joint 5	375°/s		
	Joint 6	600°/s		

Product name	Viper			
	Size	650		
	Cleanroom/IP	Standard	Cleanroom	IP54/65
Power Requirements	24 VDC: 6 A 200 to 240 VAC: 10 A, single-phase			
Protection	Base	IP40	IP40	IP54
	Robot Joints (J4, J5, J6)	IP40	IP40	IP65
Clean Class		---	Class10	---
Environment Requirements	Ambient Temperature	5 to 40°C		
	Humidity Range	5 to 90% (non-condensing)		
Weight	34 kg			
cULus Compliant	(Yes) *1			
Basic configuration	Controller	eMotionBlox-60R		
	On-board I/O (Input/Output)	12/8		
	Conveyor tracking input	2		
	RS-232C serial communications port	1		
	Programming environment	ACE, PackXpert, ePLC		
	ACE Sight	Yes		
	ePLC Connect	Yes		
	ePLC I/O	Yes		
Connectable controller *2	eMotionBlox-60R, SmartController EX, NJ/NX/NY Series *3			

*1. cULus option

*2. Choose a controller to suit your application.

*3. The robot version 2.3.C or later is required to connect with the NJ/NX/NY Series.

Dimensions

(Unit: mm)

Viper 650

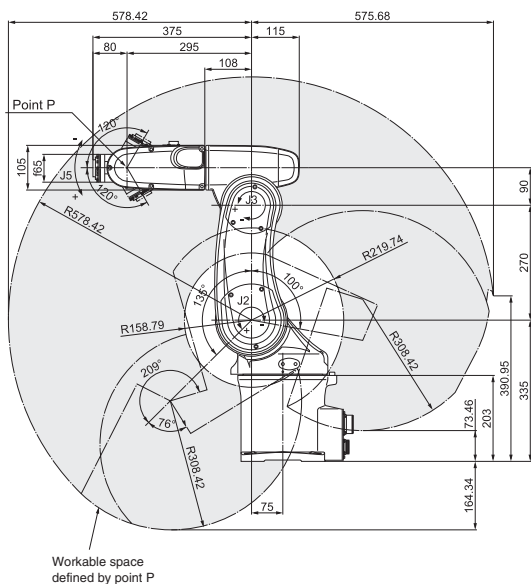

Footprint

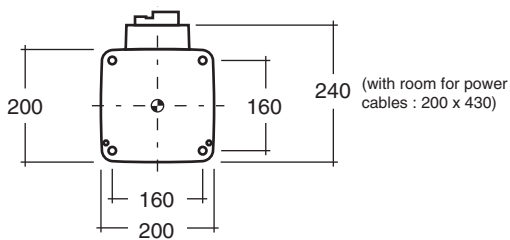

eMotionBlox-60R

Weight : 9.3 kg



Front panel

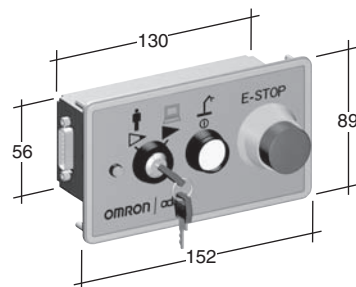

Flange

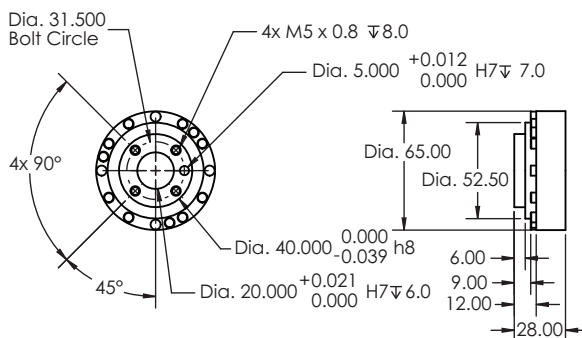

Robot Parts Code and Bundled Accessories

Type	Viper			Viper Add-On			
	Cleanroom/IP	Standard	Cleanroom	IP54/65	Standard	Cleanroom	IP54/65
Viper 650		17201-36000	17201-36020	17201-36010	17203-36000	17203-36020	17203-36010
Overview		Robot + eMotionBlox-60R amplifier with fully integrated controls			Robot + eMotionBlox-60R + required connection cables		
Purpose		Typical for use in single robot system			Typically added to systems with an existing SmartController EX to create multi-robot systems		
Bundled Accessories		<ul style="list-style-type: none"> XSYSTEM cable with jumpers, 1.8 m/6 ft (13323-000) Front panel kit (90356-10358) Arm power/signal cable, 4 m/13 ft (05020-000) 			<ul style="list-style-type: none"> XSYSTEM cable with jumpers, 1.8 m/6 ft (13323-000) XSYS cable, 4.5 m/15 ft (11585-000) DB9 splitter (00411-000) 1394 latch cable, 4.5 m/15 ft (13632-045) eV+ license to connect to controller (14529-103) 		

Articulated Robots

Viper 850

Articulated robot for machining, assembly, and material handling

- Ethernet capability to control the robot through the familiar programming language (IEC 61131-3) of Machine Automation Controller NJ/NX/NY Series
- Diagnostics display enables faster trouble shooting
- High-resolution, absolute encoders to provide high accuracy, superior slow-speed following, and easy calibration
- High-efficiency, low-inertia Harmonic Drives and a lightweight arm to deliver maximum acceleration
- Reach 855 mm
- Maximum payload 5 kg
- Weight 36 kg



Specifications

Product name		Viper		
		850		
Size		Standard	Cleanroom	IP54/65
Cleanroom/IP		1720[]-38000	1720[]-38020	1720[]-38010
Model		1720[]-38000	1720[]-38020	1720[]-38010
Mounting		Table/Floor/Inverted		
Number of axes		6		
Reach		855 mm		
Maximum Payload		5 kg		
Repeatability	XYZ	±0.03 mm		
Joint Range	Joint 1	±170°		
	Joint 2	-190°, +45°		
	Joint 3	-29°, +256°		
	Joint 4	±190°		
	Joint 5	±120°		
	Joint 6	±360°		
Inertia Moment (Max.)	Joint 4	0.295 kgm ²		
	Joint 5	0.295 kgm ²		
	Joint 6	0.045 kgm ²		
Joint Speeds	Joint 1	250°/s		
	Joint 2	250°/s		
	Joint 3	250°/s		
	Joint 4	375°/s		
	Joint 5	375°/s		
	Joint 6	600°/s		

Product name		Viper		
		850		
Size		Standard	Cleanroom	IP54/65
Cleanroom/IP		1720[]-38000	1720[]-38020	1720[]-38010
Power Requirements		24 VDC: 6 A 200 to 240 VAC: 10 A, single-phase		
Protection	Base	IP40	IP40	IP54
	Robot Joints (J4, J5, J6)	IP40	IP40	IP65
Clean Class		---	Class10	---
Environment Requirements	Ambient Temperature	5 to 40°C		
	Humidity Range	5 to 90% (non-condensing)		
Weight		36 kg		
cULus Compliant		---		
Basic configuration	Controller	eMotionBlox-60R		
	On-board I/O (Input/Output)	12/8		
	Conveyor tracking input	2		
	RS-232C serial communications port	1		
	Programming environment	ACE, PackXpert, ePLC		
	ACE Sight	Yes		
	ePLC Connect	Yes		
	ePLC I/O	Yes		
Connectable controller *1		eMotionBlox-60R, SmartController EX, NJ/NX/NY Series *2		

*1. Choose a controller to suit your application.

*2. The robot version 2.3.C or later is required to connect with the NJ/NX/NY Series.

Dimensions

(Unit: mm)

Viper 850

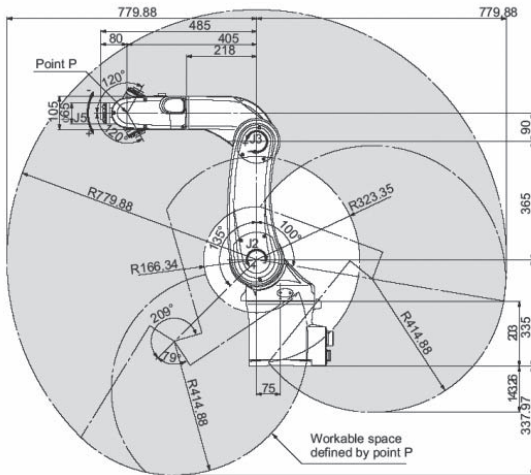

eMotionBlox-60R

Weight : 9.3 kg

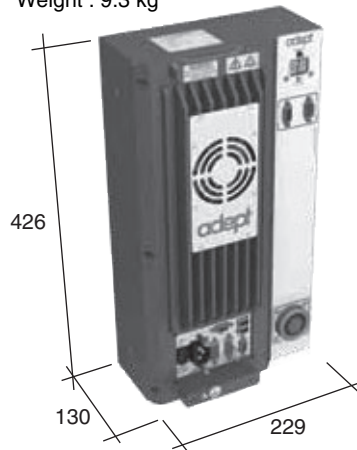

Front panel

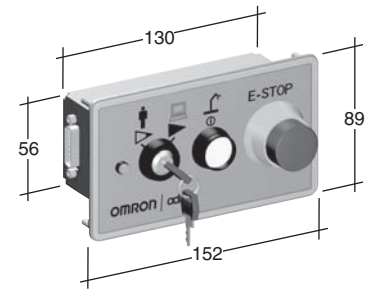

Footprint

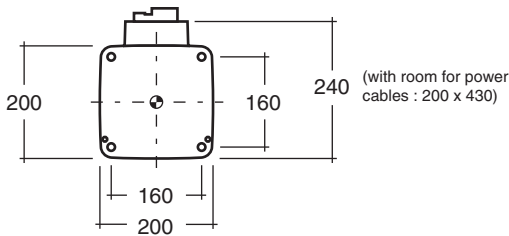

Flange

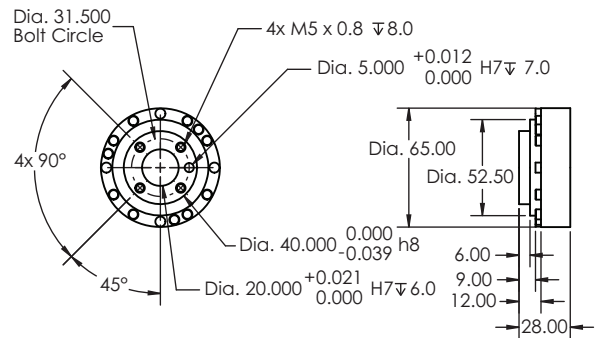

Robot Parts Code and Bundled Accessories

Type	Viper			Viper Add-On			
	Cleanroom/IP	Standard	Cleanroom	IP54/65	Standard	Cleanroom	IP54/65
Viper 850		17201-38000	17201-38020	17201-38010	17203-38000	17203-38020	17203-38010
Overview	Robot + eMotionBlox-60R amplifier with fully integrated controls				Robot + eMotionBlox-60R + required connection cables		
Purpose	Typical for use in single robot system				Typically added to systems with an existing SmartController EX to create multi-robot systems		
Bundled Accessories	<ul style="list-style-type: none"> XSYSTEM cable with jumpers, 1.8 m/6 ft (13323-000) Front panel kit (90356-10358) Arm power/signal cable, 4 m/13 ft (05020-000) 				<ul style="list-style-type: none"> XSYSTEM cable with jumpers, 1.8 m/6 ft (13323-000) XSYS cable, 4.5 m/15 ft (11585-000) DB9 splitter (00411-000) 1394 latch cable, 4.5 m/15 ft (13632-045) eV+ license to connect to controller (14529-103) 		

Automation Control Environment (ACE)

ACE provides a host of innovative features that allow you to increase productivity while streamlining configuration setup

ACE is a PC-based software package that helps you quickly and easily set up your robot system. The software makes it easy to configure single and multi-robot systems.

- ACE PackXpert is the intelligent software choice designed to manage packaging systems from integration to deployment
- ACE PackXpert provides the underlying robot programming based on the system configuration
- Built-in customization allows for any line configuration and advanced load balancing
- Wizard-based user-friendly interface to calibrate and teach the robots
- Tightly-integrated vision option (ACE Sight) enables vision guided conveyor-tracking
- Display and share process statistics
- Built-in UI Builder to create a custom operator interface

ACE PackXpert

ACE PackXpert is intelligent software designed to manage a packaging line from integration and deployment through operation. The software walks you through the configuration of packaging applications by setting up process-specific items, such as controllers, robots, and conveyor belts.

Scalable

Manage robots on packaging lines

Fast

Deploy your application faster through a user-friendly GUI

Reusable

Use across a variety of applications

Complete

Adjust control settings through V+ and C#

Versatile

No lengthy programming required

Adaptable

Create your own operator interface with the built-in UI Builder

Visual

Get a 3D view of your packaging line

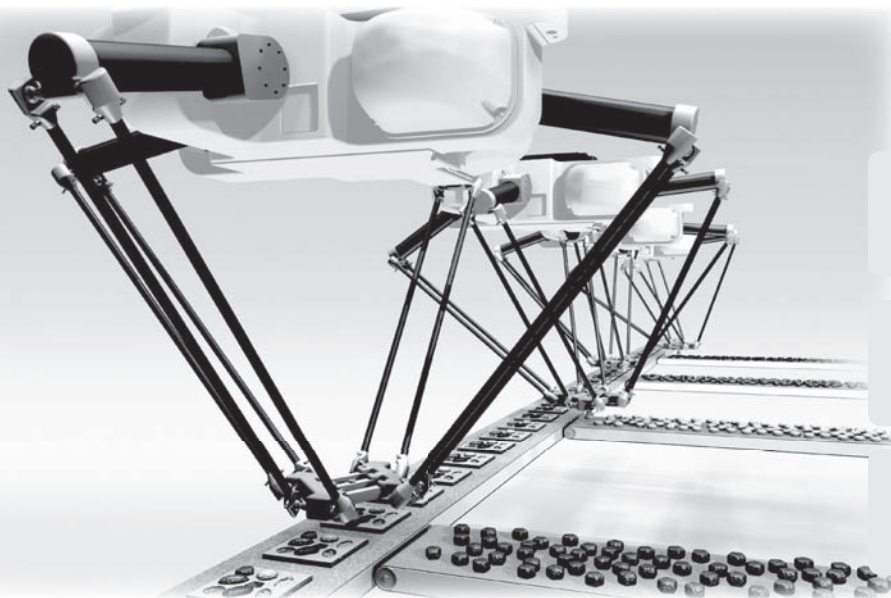

Note: When ACE PackXpert is used to configure an application, robot cycle time may vary between the SmartController EX and eAIB/eMotionBox.

ACE License Configuration

License	Explanation
ACE PackXpert	Enables full functionality of the ACE PackXpert software.
ACE Sight Vision Software	Enables the ACE Sight software functionality.

Note: When you create robot programs without using PackXpert wizards and Vision System, the ACE license is not required.

System Requirements

Item	Requirement
Operating system (OS)	Windows Vista (32-bit version) / Windows 7 (32-bit/64-bit version) / Windows 8 (32-bit/64-bit version) / Windows 8.1 (32-bit/64-bit version) / Windows 10 (32-bit/64-bit version)
CPU	Intel® Core™ i7 or equivalent or faster recommended.
Main memory	2 GB min. (8 GB min. recommended.)
Video memory	512 MB min.
Hard disk	At least 1 GB of available space
Display	XGA 1,024 × 768, 16 million colors. WXGA 1,280 × 800 min. recommended
Communications ports	USB port (for hardware key), Ethernet port
Supported languages	Japanese, English, German, simplified Chinese



Automation Control Environment (ACE)

ACE is a PC-based software package that helps you quickly and easily set up your robot system. ACE is available to download from the Omron website:
<http://www.ia.omron.com/>

SmartController EX

High-performance robot motion controller capable of high-speed processing

- Controls up to four robots
- Gigabit Ethernet
- 12 inputs/8 outputs
- Ultra-compact form factor for high footprint efficiency
- Integration with configuration software ACE to control complex mechanisms through user-friendly interface



Specifications

Item	Specifications	
Model	19300-000	
Grounding Method	Ground to less than 10 Ω	
Dimensions (Height × Depth × Width)	86 × 187 × 329 mm	
Weight	2.6 kg	
Power Supply	24 VDC±10%	
Current Consumption	5 A	
Power Consumption	120 W	
Operation Environment	Ambient Temperature	5 to 40°C
	Humidity Range	5 to 90% (non-condensing)
Mounting	Panel mount, rack mount, stack mount, desktop	
Communications Port	RS-232 (115 kbps), RS422/485, Gigabit Ethernet, DeviceNet	
On-board I/O (Input/Output)	12/8	
Conveyor tracking input	4	

Dimensions

(Unit: mm)

SmartController EX



Front panel

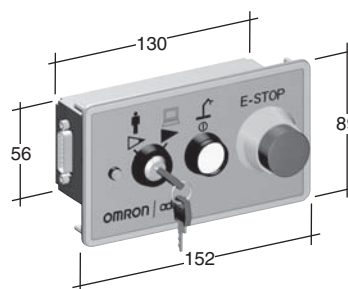

Note: Front Panel is provided with the SmartControllerEX.

Additional I/O Options

Input Specifications

Item	Specifications
Model	90356-30200/-30100/-40100
ON Voltage	10 V min.
OFF Voltage	3 V max.
OFF Current	0.5 mA
Input Current	2.5 mA min. 7.5 mA max.
ON Delay Time	5 μs max.
OFF Delay Time	5 μs max.
Isolation Method	Photocoupler isolation
Current Consumption from I/O Power Supply	6 mA max. (at power supply voltage of 24 VDC)

Output Specifications

Item	Specifications
Model	90356-30200/-30100/-40100
Rated Output Current	700 mA/point
Maximum Output Current	2.5 A at 50°C ambient 3.7 mA at 25°C ambient
ON Delay Time	100 μs max.
OFF Delay Time	150 μs max.

SmartVision MX

Dependable vision system optimized for robot applications

- Fanless construction
- Supports up to eight cameras simultaneously
- Capable of processing high resolution and high frame rate images
- Dedicated software ACE Sight provides easy-to-use object location and inspection tools
- GigE PoE and USB 3.0 ports for a wide variety of cameras
- A wide operating temperature range and SSD ensure high reliability



Specifications

Item		Specifications
Model		14189-901
Grounding Method		Ground to less than 10 Ω
Dimensions (Height × Depth × Width)		68 × 150 × 260 mm
Weight		2.16 kg
CPU		Intel® Core™ i7
Main Memory		8 GB DDR3 RAM
Power Supply		10 to 32 VDC
Current Consumption		4.2 A (24 VDC), 7.0 A max. (when using 4 cameras)
Power Consumption		9 to 36 VDC
Operation Environment	Ambient Temperature	0 to 50°C
	Humidity Range	5 to 90% (non-condensing)
Communications Port	Ethernet	Gigabit Ethernet × 2, Gigabit Ethernet with PoE × 4 15.7 W per channel
	USB	USB 3.0 × 4, USB 2.0 × 2
	Display	DVI-D × 1 (up to 1,920 × 1,200 @ 60 Hz), DVI-I × 1 (up to 2,048 × 1,536 @ 75 Hz)

Dimensions

(Unit: mm)

SmartVision MX

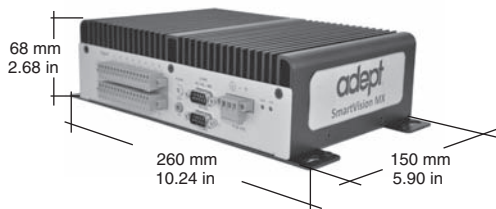

Dongle



Note: The dongle is bundled with the ACE License. Insert the dongle into the USB port of the SmartVision MX.

Camera Variations

	GigE type						
							
Model	24114-101	24114-200	24114-201	24114-250	24114-251	24114-300	24114-301
Image elements	1/4-inch CCD	1/3-inch CCD	1/3-inch CCD	1/1.8-inch CMOS	1/1.8-inch CMOS	1-inch CMOS	1-inch CMOS
Effective pixels	658(H) x 492(V)	1296(H) x 966(V)	1294(H) x 964(V)	1602(H) x 1202(V)	1600(H) x 1200(V)	2048(H) x 2048(V)	2046(H) x 2046(V)
Color/Monochrome	Color	Monochrome	Color	Monochrome	Color	Monochrome	Color
Frame rate	120 fps	30 fps	30 fps	60 fps	60 fps	25 fps	25fps
Trigger input	<ul style="list-style-type: none"> • Software trigger • External trigger 			<ul style="list-style-type: none"> • Software trigger 		<ul style="list-style-type: none"> • Software trigger • External trigger 	
I/F	Gigabit Ethernet (1 Gbit/s)						
Lens mounting	<ul style="list-style-type: none"> • C mount • CS mount 			<ul style="list-style-type: none"> • C mount 	<ul style="list-style-type: none"> • C mount • CS mount 		<ul style="list-style-type: none"> • C mount
Power supply voltage	PoE or 12 VDC						
Power consumption (PoE/AUX)	2.5 W/2.0 W	2.7 W/2.2 W		2.7 W/2.1 W		3.1 W/2.6 W	
Weight	Approx. 90 g						
Bundled cables	Camera Cable, 10 m (14359-000) Power I/O Cable, 10 m (09454-610)						

Pendant T20 Pendant

Excellent operability and ergonomic design

- Tested for a 1.5 meter drop onto industrial flooring
- Displays custom messages
- Emergency stop switch (dual channel circuit)
- Enable switch on back
- Bright display with backlight and contrast adjustment



Dimensions

(Unit: mm)

T20 Pendant



Wall Bracket Dimensions - Optional

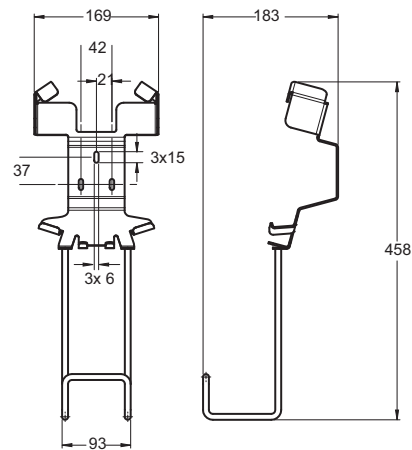

Connection to SmartController

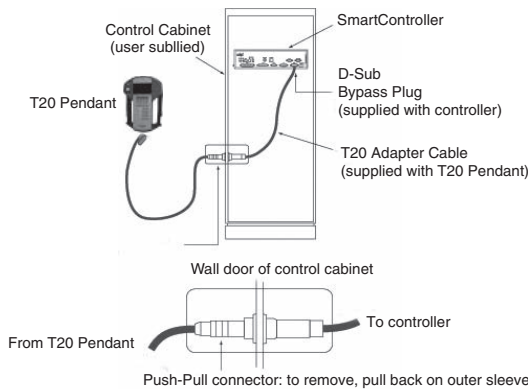

Panel and Front panel Installation

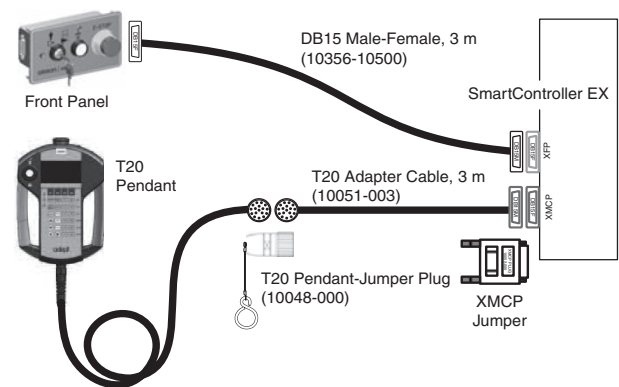

Name	Details	Model
Pendant	T20 Pendant, 10 m Cable	10046-010
	T20 Pendant-Jumper Plug	10048-000
	T20 Pendant Wall Bracket	10079-000
	T20 Adapter Cable, 3 m	10051-003

ePLC Robot Control Library

No need to learn a new robot programming language Control robots directly from the NJ/NX/NY Controller

- The same instructions and programming method can be used to control any type of robot: parallel, SCARA, or articulated robot
- Robots can be controlled by using Function Blocks in Ladder or ST language
- Data on robots, controller, and other devices can be integrated and visualized
- Robots are connected to the NJ/NX/NY Controller via EtherNet/IP. *

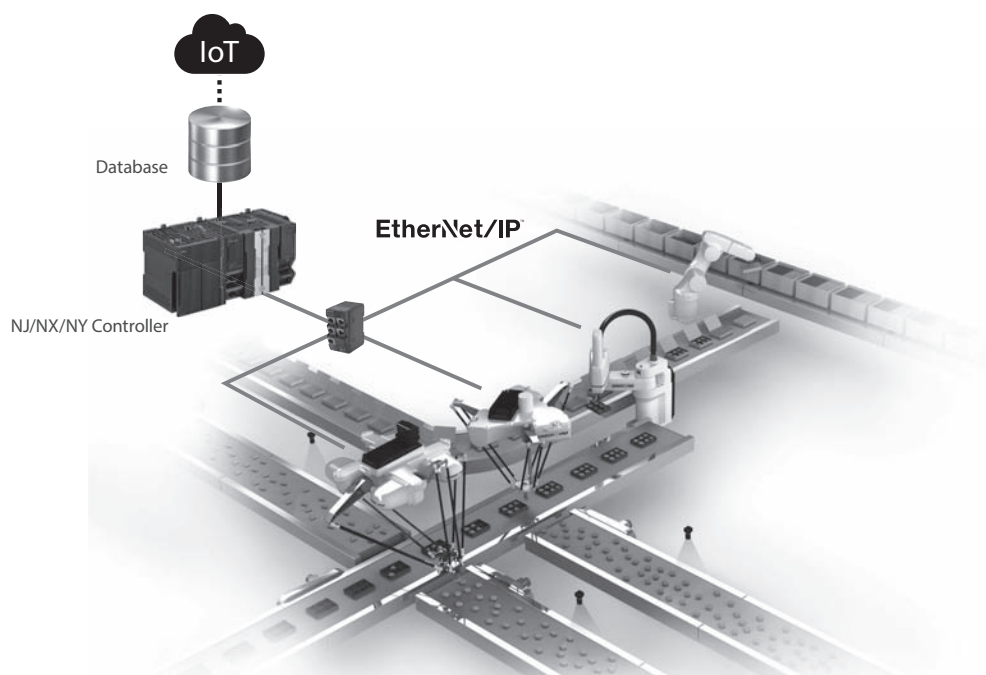

* The communication cycle time between the robot and NJ/NX/NY Controller depends on the robot controller. When the SmartController EX is used, the communications cycle time is 15 times faster than when the eAIB or eMotionBlox is used.

Function Block (FB) Specifications

Name	FB name	Description
Set Tool Trans	ARB_SetToolTransform	Sets a tool system transformation to the robot.
Reset Tool Transform	ARB_ResetToolTransform	Resets the robot tool which is set to the robot.
Define Location	ARB_DefineLocation	Defines a position in the robot.
Define Pallet	ARB_DefinePallet	Defines all pallet information in the robot.
Reset Error	ARB_ResetRobotError	Resets any existing error in the robot.
Robot Control	ARB_RobotControl	Controls the main robot settings and monitors the robot status.
Teach Position	ARB_TeachPosition	Teaches the current robot position and configuration.
Input Output Signals	ARB_InputOutputSignals	Communicates with the robot through its digital inputs and outputs.
Teach Pendant Control	ARB_TeachPendantControl	Sends and receives information from the manual control pendant attached to the robot.
Read Latch	ARB_ReadLatch	Outputs the current robot position when an external trigger is input.
Move	ARB_MoveCommand	Moves the robot to a target position using a linear interpolation or PTP operation.
Pick And Place	ARB_PickAndPlaceCommand	Moves the robot to a target position in a three-part motion.
Jog	ARB_Jog	Moves the specified joint or axis of the robot.
Align Tool Command	ARB_AlignToolCommand	Rotates the tool to be aligned with the world coordinate system.
Move Arc Command	ARB_MoveArcCommand	Moves the robot to the specified target position along arc trajectory.
Move Circular Command	ARB_MoveCircularCommand	Moves the robot along a circular trajectory, passing specified two positions.
Define Belt	ARB_DefineBelt	Defines a conveyor belt.
Belt Read Latch	ARB_BeltReadLatch	Outputs the belt encoder value of the conveyor when an external trigger is input.
Track Belt	ARB_TrackBelt	Enables tracking a workpiece.

Compatible Models

Name	Model	Version
Adept Robot Control Library	SYSMAC-XR009	---
Machine Automation Controller NJ/NX CPU Unit	NX701-[][][]/NJ101-[][][]	Version 1.10 or later
	NJ501-[][][]/NJ301-[][][]	Version 1.01 or later
	NX1P2-[][][][] (1)	Version 1.13 or later
Industrial PC Platform NY IPC Machine Controller	NY5[][]-1	Version 1.12 or later
Automation Software Sysmac Studio	SYSMAC-SE2[][][]	Version 1.15 or later
Parallel Robot	Hornet 565	1720[]-4560[]
	Quattro 650H/HS, 800H/HS	1720[]-26[][][]
SCARA Robot	eCobra 600/800	17[][][]-1[][][]00
	Cobra 450	17201-14500
Articulated Robot	Viper 650/850	1720[]-36[][]00



Sysmac Library

The Sysmac Library is a collection of software functional components that can be used in programs for the NJ/NX/NY Controllers.

Please download it from following URL and install to Sysmac Studio Automation Software.

http://www.ia.omron.com/sysmac_library/

The Adept Robot Control Library allows you to control parallel, SCARA, and articulated robots manufactured by Omron Adept Technologies Inc. from the NJ/NX/NY Controllers by using the same instructions and programming methods.

AnyFeeder

Feeding bulk parts for alignment and assembly

- Flip, forward, and backward for easy pickup by robot in combination with vision
- Pickup after flipping parts to identify front or rear
- Easy configuration of AnyFeeder, vision, and robots using wizards in ACE software
- Flexible feeding of various parts registered in Recipe Manager in ACE software
- Available with all models of SCARA, articulated, and parallel robots

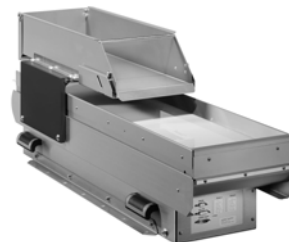

Ordering Information

Product Name		SXM-100	SXM-140
FlexFactory model		900-001-161	900-001-162
Omron model		09725-500 *	18819-500 *
Field of Vision		100 x 134 mm	140 x 193 mm
Suitable for Parts	Material	Metal, Plastic, Glass (Stable)	Metal, Plastic, Glass (Stable)
	Main dimensions	< 30 mm	< 45 mm
	Thickness	> 0.15 mm	> 0.15 mm
	Weight	< 15 g	< 25 g
Maximum Weight in Field of Vision		500 g	500 g
Connections	Electrical	1	1
	Pneumatic	-	-
	Serial	1	1
Weight		18 kg	22 kg
Power Requirements		24 VDC 10 A	24 VDC 10 A
Typical Power Usage		100 W (usage dependent)	100 W (usage dependent)
Air Requirements		-	-
Drivers		2 brushless servomotors 130 W	2 brushless servomotors 130 W
Data interface		RS232 (D-SUB 9 connector)	RS232 (D-SUB 9 connector)
Environmental Requirements	Temperature	5 - 45°C	5 - 45°C
	Humidity	5 - 90% (non-condensing)	5 - 90% (non-condensing)
Materials of construction	Main unit	Stainless Steel 1.4301 (304)	Stainless Steel 1.4301 (304)
	Feeder platform	Stainless Steel 1.4301 (304)	Stainless Steel 1.4301 (304)
	Feed surface border	Stainless Steel 1.4301 (304)	Stainless Steel 1.4301 (304)
	Bulk Container	Stainless Steel 1.4301 (304)	Stainless Steel 1.4301 (304)

Product Name		SX-240	SX-340
FlexFactory model		900-001-164	900-001-165
Omron model		12480-500 *	14269-500 *
Field of Vision		240 x 320 mm	340 x 453 mm
Suitable for Parts	Material	Metal, Plastic, Glass (Stable)	Metal, Plastic, Glass (Stable)
	Main dimensions	< 75 mm	< 110 mm
	Thickness	> 0.5 mm	> 0.5 mm
	Weight	< 60 g	< 80 g
Maximum Weight in Field of Vision		1500 g	1500 g
Connections	Electrical	1	1
	Pneumatic	1	1
	Serial	1	1
Weight		50 kg / 110 lb	55 kg / 121 lb
Power Requirements		24 VDC 10 A	24 VDC 10 A
Typical Power Usage		100 W (usage dependent)	100 W (usage dependent)
Air Requirements		6 bar / 87 psi, compressed air, filtered, unlubricated	6 bar / 87 psi, compressed air, filtered, unlubricated
Drivers		2 brushless servomotors 130 W	2 brushless servomotors 130 W
Data interface		RS232 (D-SUB 9 connector)	RS232 (D-SUB 9 connector)
Environmental Requirements	Temperature	5 - 45°C	5 - 45°C
	Humidity	5 - 90% (non-condensing)	5 - 90% (non-condensing)
Materials of construction	Main unit	Stainless Steel 1.4301 (304)	Stainless Steel 1.4301 (304)
	Feeder platform	Stainless Steel 1.4301 (304)	Stainless Steel 1.4301 (304)
	Feed surface border	Stainless Steel 1.4301 (304)	Stainless Steel 1.4301 (304)
	Bulk Container	Stainless Steel 1.4301 (304)	Stainless Steel 1.4301 (304)

* Power Cable, AnyFeeder, 5m and RS232 Cable, AnyFeeder, 4.5m are provided with the AnyFeeder.

Dimensions

(Unit: mm)

SXM-100

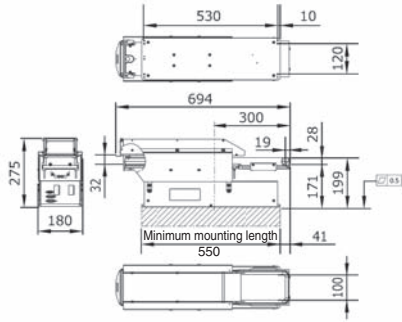

SXM-140

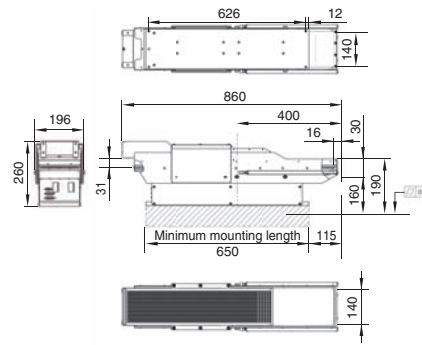

SX-240

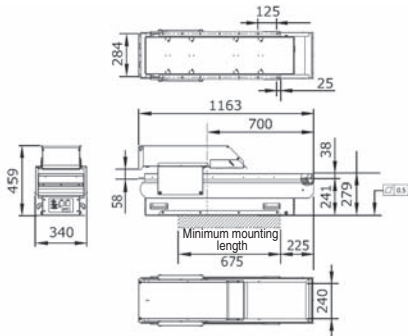

SX-340

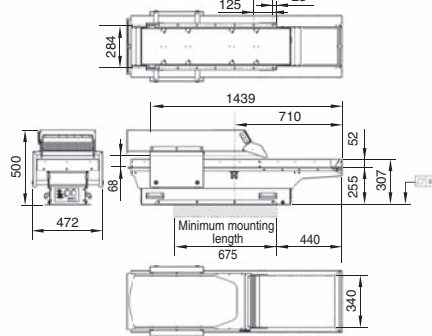



Options

Type	Name/Specifications	FlexFactory model	Omron model
Backlight	Backlight - IR 875 nm, SXM100	900-000-072	09725-202
	Backlight - Red 630 nm, SXM100	900-000-367	09725-201
	Backlight - IR 875 nm, SXM140	900-000-215	14630-000
	Backlight - Red 630 nm, SXM140	900-000-346	14630-001
	Backlight - IR 875 nm, SX240	900-000-158	05284-208
	Backlight - Red 630 nm, SX240	900-000-238	05284-206
	Backlight - IR 875 nm, SX340	900-000-235	14269-001
	Backlight - Red 630 nm, SX340	900-000-373	14269-002
Surface	Surface, POM-C, Flat, Light Brown, ESD, SXM100	007-001-679	09725-104
	Surface, POM-C, Flat, Black, SXM100 (Not available with backlight)	003-562-000	09725-102
	Surface, POM-C, Flat, Black, ESD, SXM100 (Not available with backlight)	007-001-357	09725-103
	Surface, POM-C, Flat, White, SXM100	002-290-000	09725-101
	Surface, POM-C, Flat, Light Brown, ESD, SXM140	007-001-012	09725-303
	Surface, POM-C, Flat, Black, SXM140 (Not available with backlight)	004-931-000	09725-302
	Surface, POM-C, Flat, White, SXM140	003-965-100	09725-301
	Surface, PVC, Flat, Light Gray, SXM140 (Not available with backlight)	007-001-359	09725-304
	Surface, POM-C Flat, Light Brown, ESD, SX240	007-001-046	05284-103
	Surface, POM-C, Flat, Black, SX240 (Not available with backlight)	001-821-000	05284-102
	Surface, POM-C, Flat, Black, ESD, SX240 (Not available with backlight)	007-001-794	05284-104
	Surface, POM-C, Flat, White, SX240	001-820-000	05284-101
	Surface, PVC, Flat, Gray, SX240 (Not available with backlight)	005-434-000	05284-105
	Surface, POM-C Flat, Light Brown, ESD, SX340	007-001-791	14269-005
	Surface, POM-C, Flat, Black, SX340 (Not available with backlight)	005-386-000	14269-004
	Surface, PVC, Flat, Light Gray, SX340 (Not available with backlight)	007-001-295	14269-006
Surface, POM-C, Flat, White, SX340	004-439-000	14269-003	
Others	ESD Option, SX240	900-000-241	05284-204
	Filter, Daylight, M27 x 5	-	09324-000

System Configuration

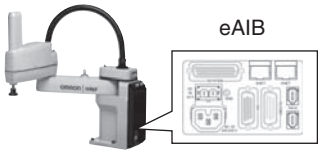
Amplifiers with Built-in Controller

Robot	Description
Hornet 565, eCobra	Embedded into the robot. (eAIB) 
Cobra 450, Viper	A separate amplifier (eMotionBlox). Bundled with the robot. 
Quattro	A separate controller (SmartController EX). Bundled with the robot. eAIB amplifier/controller embedded into the robot. (The SmartController EX can be sold separately.) 

Basic configuration

Control by eAIB/eMotionBlox

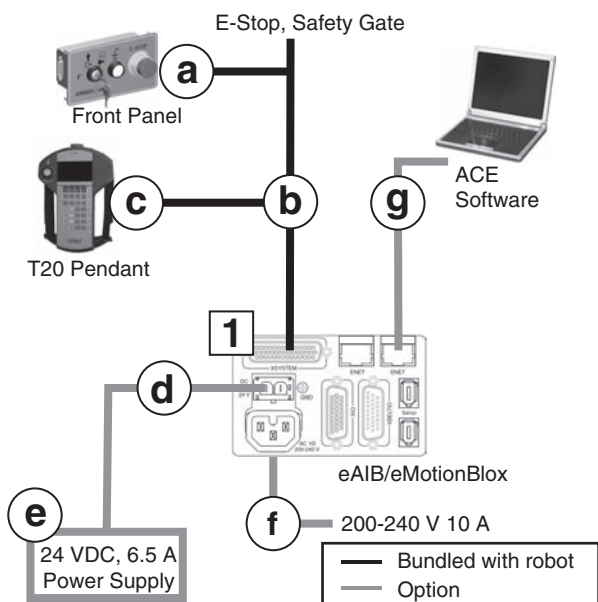

Control by SmartController EX

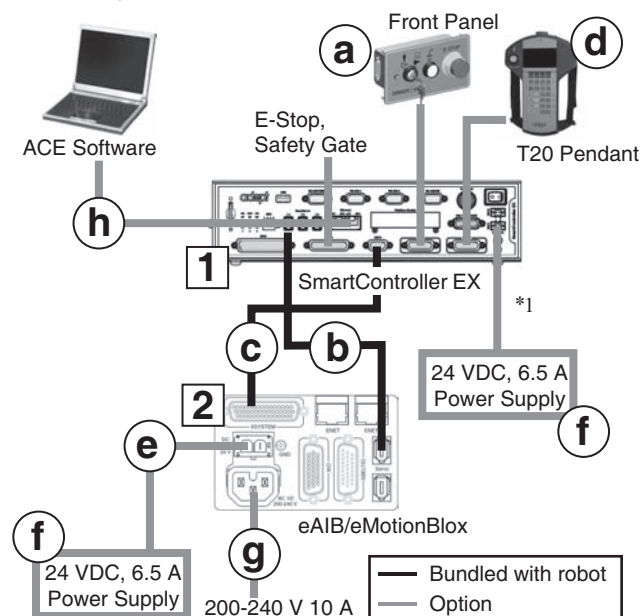

Cobra 450, eCobra, Viper, Hornet

Part	Name	Model	Note	Qty
1	Robot	17[][][]-[][][][]		1
a	Front Panel with Cable *1	90356-10358	Bundled with Robot	(1)
b	eAIB XSYSTEM Cable	13323-000	Bundled with Robot	(1)
c	T20 Pendant with Cable	10046-010		1
d	24 VDC Power Cable	04120-000		1
e	24 VDC, 6.5 A Power Supply	S8FS-G15024C or S8FS-G15024D		1
f	AC Power Cable	04118-000		1
g	Ethernet Cable	XS6W-6LSZH8SS [][][]CM-Y		1
---	ACE PackXpert License	09187-000	When you create robot programs without using wizards, the ACE license is not required.	1

*1. The Front Panel is not included with the Cobra 450.

Quattro

Part	Name	Model	Note	Qty
2	Robot	17214-2[][][][]		1
1	SmartController EX	09200-000	Bundled with Robot	(1)
a	Front Panel with Cable	90356-10358	Bundled with Robot	(1)
b	IEEE 1394 cable	13632-045	Bundled with Robot	(1)
c	eAIB XSYS Cable	11585-000	Bundled with Robot	(1)
d	T20 Pendant with Cable	10046-010		1
e	24 VDC Power Cable	04120-000		1
f	24 VDC, 6.5 A Power Supply	S8FS-G15024C or S8FS-G15024D		2
g	AC Power Cable	04118-000		1
h	Ethernet Cable	XS6W-6LSZH8SS[][][]CM-Y		1
---	ACE PackXpert License	09187-000	When you create robot programs without using wizards, the ACE license is not required.	1

*1. User-supplied shielded power cable.

Vision tracking robot system

Control by eAIB/eMotionBloX with SVMX (When using a vision system)

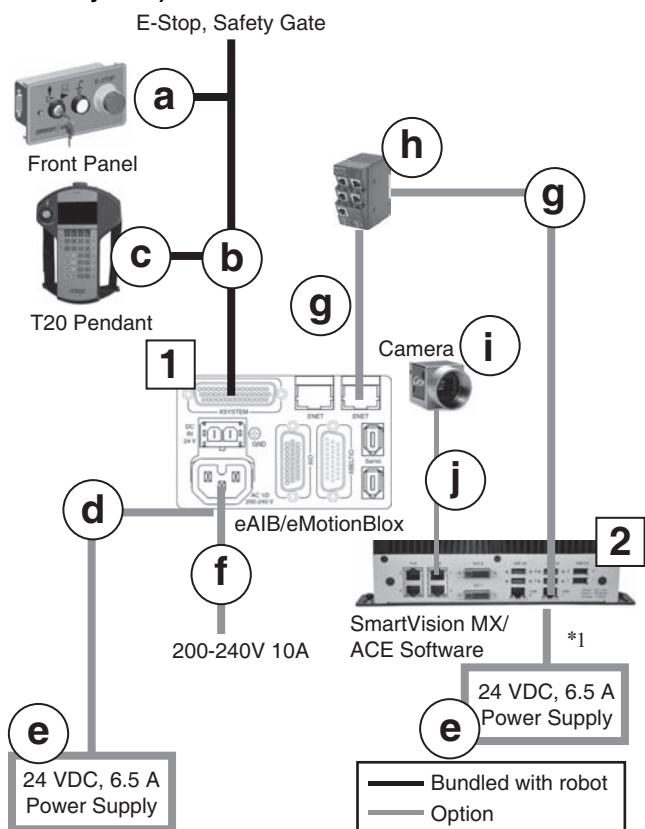

Control by SmartController EX (When using a vision system)

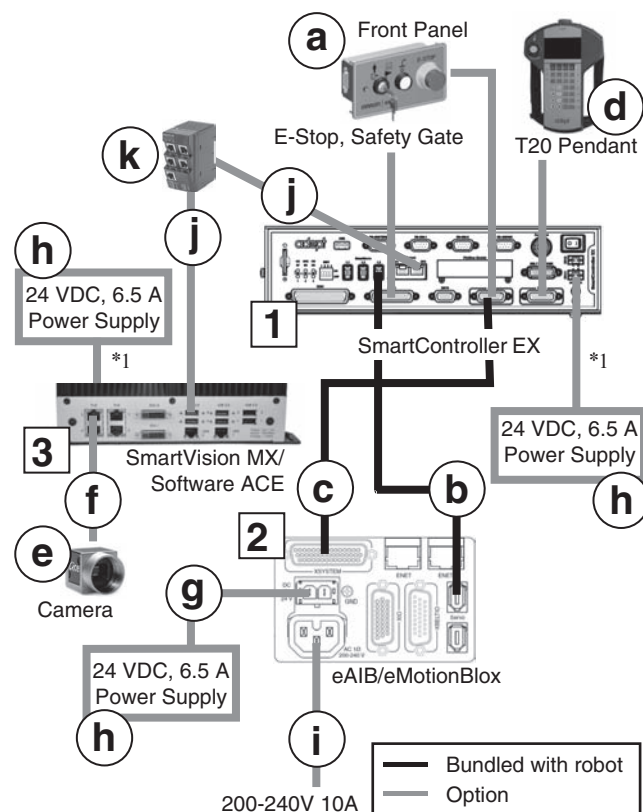

Cobra 450, eCobra, Viper, Hornet

Part	Name	Model	Note	Qty
1	Robot	17[][][][][][][]		1
a	Front Panel with Cable *2	90356-10358	Bundled with Robot	(1)
b	eAIB XSYSTEM Cable	13323-000	Bundled with Robot	(1)
c	T20 Pendant with Cable	10046-010		1
d	24 VDC Power Cable	04120-000		1
e	24 VDC, 6.5 A Power Supply	S8FS-G15024C or S8FS-G15024D		2
f	AC Power Cable	04118-000		1
g	Ethernet Cable	XS6W-6LSZH8SS [][][]CM-Y		2
h	Industrial Switching Hubs	W4S1-05C		1
2	SmartVision MX	14189-901	Bundling a 24 VDC connector	1
i	Camera	241[][][][][][]		1 *3
j	Camera cable	---	Bundled with Camera	1 *3
---	ACE PackXpert with ACE Sight Vision License	09187-010		1

*1. User-supplied shielded power cable.

*2. The Front Panel is not included with the Cobra 450.

*3. Qty depends on system.

Quattro

Part	Name	Model	Note	Qty
2	Robot	17214-2[][][][]		1
1	SmartController EX	09200-000	Bundled with Robot	(1)
a	Front Panel with Cable	90356-10358	Bundled with Robot	(1)
b	IEEE 1394 cable	13632-045	Bundled with Robot	(1)
c	eAIB XSYS Cable	11585-000	Bundled with Robot	(1)
d	T20 Pendant with Cable	10046-010		1
3	SmartVision MX	14189-901		1
e	Camera	241[][][][][][]		1 *2
f	Camera cable	---	Bundled with Camera	1 *2
g	24 VDC Power Cable	04120-000		1
h	24 VDC, 6.5 A Power Supply	S8FS-G15024C or S8FS-G15024D		3
i	AC Power Cable	04118-000		1
j	Ethernet Cable	XS6W-6LSZH8SS [][][]CM-Y		2
k	Industrial Switching Hubs	W4S1-05C		1
---	ACE PackXpert with ACE Sight Vision License	09187-010		1

*1. User-supplied shielded power cable.

*2. Qty depends on system.

Conveyor tracking robot system

Control by eAIB/eMotionBlox with SVMX (When using a vision system)

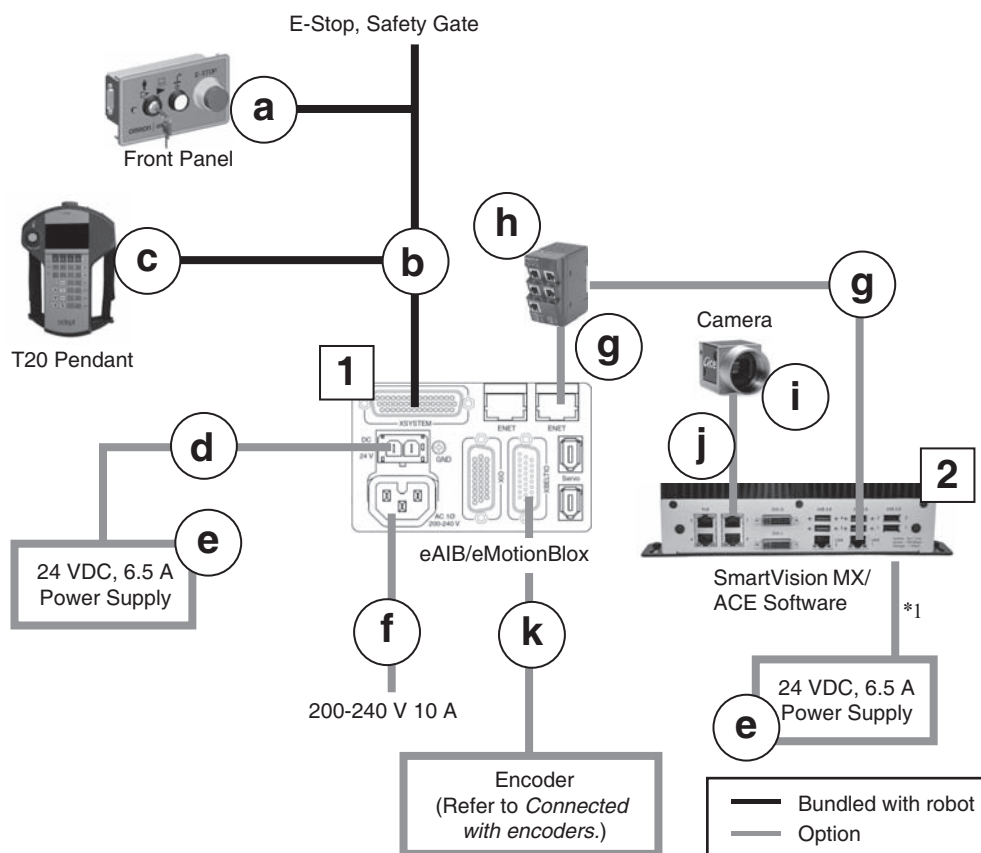

Cobra 450, eCobra, Viper, Hornet

Part	Name	Model	Note	Qty
1	Robot	17[][]-[][][][]		1
a	Front Panel with Cable *2	90356-10358	Bundled with Robot	(1)
b	eAIB XSYSTEM Cable	13323-000	Bundled with Robot	(1)
c	T20 Pendant with Cable	10046-010		1
d	24 VDC Power Cable	04120-000		2
e	24 VDC, 6.5 A Power Supply	S8FS-G15024C or S8FS-G15024D		1
f	AC Power Cable	04118-000		1
g	Ethernet Cable	XS6W-6LSZH8SS[][][]CM-Y		2
h	Industrial Switching Hubs	W4S1-05C		1
2	SmartVision MX	14189-901	Bundling a 24 VDC connector	1
i	Camera	241[][]-[][][]		1 *3
j	Camera cable	---	Bundled with Camera	1 *3
k	XBELTIO Cable	13463-000		1
---	ACE PackXpert with ACE Sight Vision License	09187-010		1

*1. User-supplied shielded power cable.

*2. The Front Panel is not included with the Cobra 450.

*3. Qty depends on system.

Conveyor tracking robot system by SCEX

Control by SCEX with SVMX (When using a vision system)

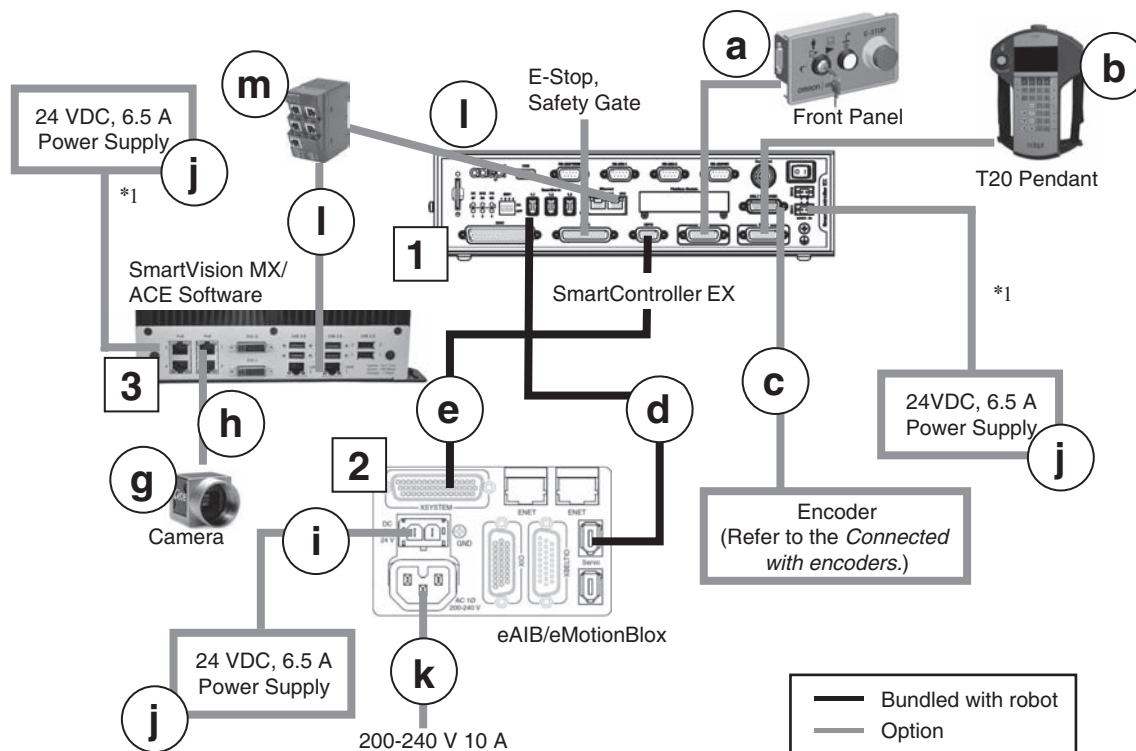

Cobra 450, eCobra, Viper, Hornet

Part	Name	Model	Note	Qty
1	SmartController EX	19300-000		1
a	Front Panel with Cable *2	90356-10358	Bundled with SmartController EX	(1)
b	T20 Pendant with Cable	10046-010		1
c	SCEX-BELT, Y-Adapter Cable	09550-000		1
2	Robot Add on	17[][3-][][][][]		1
d	IEEE 1394 cable	13632-045	Bundled with Robot Add on	(1)
e	eAIB XSYS Cable	11585-000	Bundled with Robot Add on	(1)
f	DB9 splitter	00411-000	Bundled with Robot Add on (Not used in this configuration)	(1)
3	SmartVision MX	14189-901	Bundling a 24 VDC connector	1
g	Camera	241[][]-[][][][]		1*3
h	Camera cable	---	Bundled with Camera	1*3
i	24 VDC Power Cable	04120-000		1
j	24 VDC, 6.5 A Power Supply	S8FS-G15024C or S8FS-G15024D		3
k	AC Power Cable	04118-000		1
l	Ethernet Cable	XS6W-6LSZH8SS [][][]CM-Y		2
m	Industrial Switching Hubs	W4S1-05C		1
---	ACE PackXpert with ACE Sight Vision License	09187-010		1

*1. User-supplied shielded power cable.

*2. The Front Panel is not included with the Cobra 450.

*3. Qty depends on system.

Quattro

Part	Name	Model	Note	Qty
2	Robot	17214-2[][][][]		1
1	SmartController EX	09200-000	Bundled with Robot	(1)
a	Front Panel with Cable	90356-10358	Bundled with Robot	(1)
d	IEEE 1394 cable	13632-045	Bundled with Robot	(1)
e	eAIB XSYS Cable	11585-000	Bundled with Robot	(1)
b	T20 Pendant with Cable	10046-010		1
c	SCEX-BELT, Y-Adapter Cable	09550-000		1
3	SmartVision MX	14189-901	Bundling a 24 VDC connector	1
g	Camera	241[][]-[][][][]		1*2
h	Camera cable	---	Bundled with Camera	1*2
i	24 VDC Power Cable	04120-000		1
j	24 VDC, 6.5 A Power Supply	S8FS-G15024C or S8FS-G15024D		3
k	AC Power Cable	04118-000		1
l	Ethernet Cable	XS6W-6LSZH8SS [][][]CM-Y		2
m	Industrial Switching Hubs	W4S1-05C		1
---	ACE PackXpert with ACE Sight Vision License	09187-010		1

*1. User-supplied shielded power cable.

*2. Qty depends on system.

Conveyor tracking dual-robot system

2 robots controlled by SCEX with SVMX (When using a vision system)

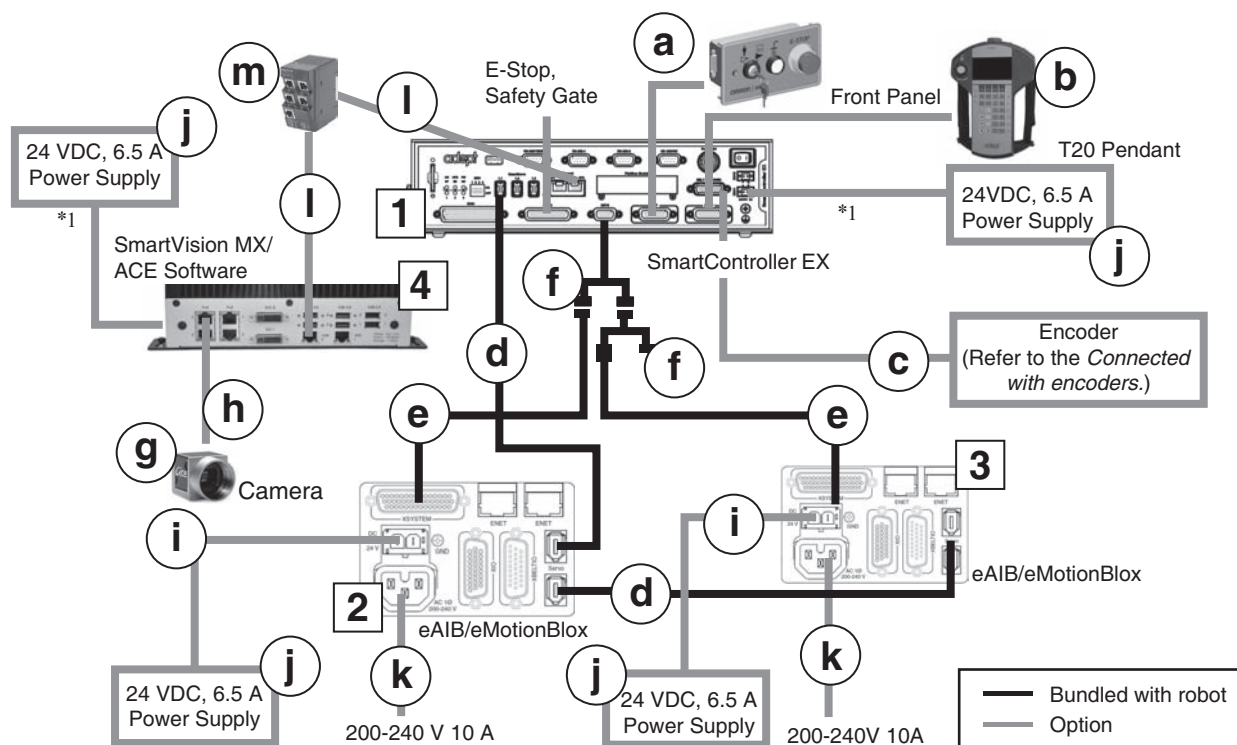

Cobra 450, eCobra, Viper, Hornet

Part	Name	Model	Note	Qty
1	SmartController EX	19300-000		1
a	Front Panel with Cable *2	90356-10358	Bundled with SmartController EX	(1)
b	T20 Pendant with Cable	10046-010		1
c	SCEX-BELT, Y-Adapter Cable	09550-000		1
2, 3	Robot Add on	17[][3-[][][]]		2
d	IEEE 1394 cable	13632-045	Bundled with Robot Add on	(2)
e	eAIB XSYS Cable	11585-000	Bundled with Robot Add on	(2)
f	DB9 splitter	00411-000	Bundled with Robot Add on	(2)
4	SmartVision MX	14189-901	Bundling a 24 VDC connector	1
g	Camera	241[][-[][][]]		1 *3
h	Camera cable	---	Bundled with Camera	1 *3
i	24 VDC Power Cable	04120-000		2
j	24 VDC, 6.5 A Power Supply	S8FS-G15024C or S8FS-G15024D		4
k	AC Power Cable	04118-000		2
l	Ethernet Cable	XS6W-6LSZH8SS[][][] CM-Y		2
m	Industrial Switching Hubs	W4S1-05C		1
---	ACE PackXpert with ACE Sight Vision License	09187-010		1

*1. User-supplied shielded power cable.

*2. The Front Panel is not included with the Cobra 450.

*3. Qty depends on system.

Quattro

Part	Name	Model	Note	Qty
2	Robot	17214-2[][][]]		1
1	SmartController EX	09200-000	Bundled with Robot	(1)
a	Front Panel with Cable	90356-10358	Bundled with Robot	(1)
d	IEEE 1394 cable	13632-045	Bundled with Robot	(1)
e	eAIB XSYS Cable	11585-000	Bundled with Robot	(1)
b	T20 Pendant with Cable	10046-010		1
c	SCEX-BELT, Y-Adapter Cable	09550-000		1
3	Robot Add on	17203-2[][][]]		1
d	IEEE 1394 cable	13632-045	Bundled with Robot Add on	(1)
e	eAIB XSYS Cable	11585-000	Bundled with Robot Add on	(1)
f	DB9 splitter	00411-000	Bundled with Robot Add on	(1)
4	SmartVision MX	14189-901	Bundling a 24 VDC connector	1
g	Camera	241[][-[][][]]		1 *2
h	Camera cable	---	Bundled with Camera	1 *2
i	24 VDC Power Cable	04120-000		2
j	24 VDC, 6.5 A Power Supply	S8FS-G15024C or S8FS-G15024D		4
k	AC Power Cable	04118-000		2
l	Ethernet Cable	XS6W-6LSZH8SS[][][] CM-Y		2
m	Industrial Switching Hubs	W4S1-05C		1
---	ACE PackXpert with ACE Sight Vision License	09187-010		1

*1. User-supplied shielded power cable.

*2. Qty depends on system.

Vision tracking robot system

Control by eAIB/eMotionBlox (Status monitoring by NJ/NX/NY Series)

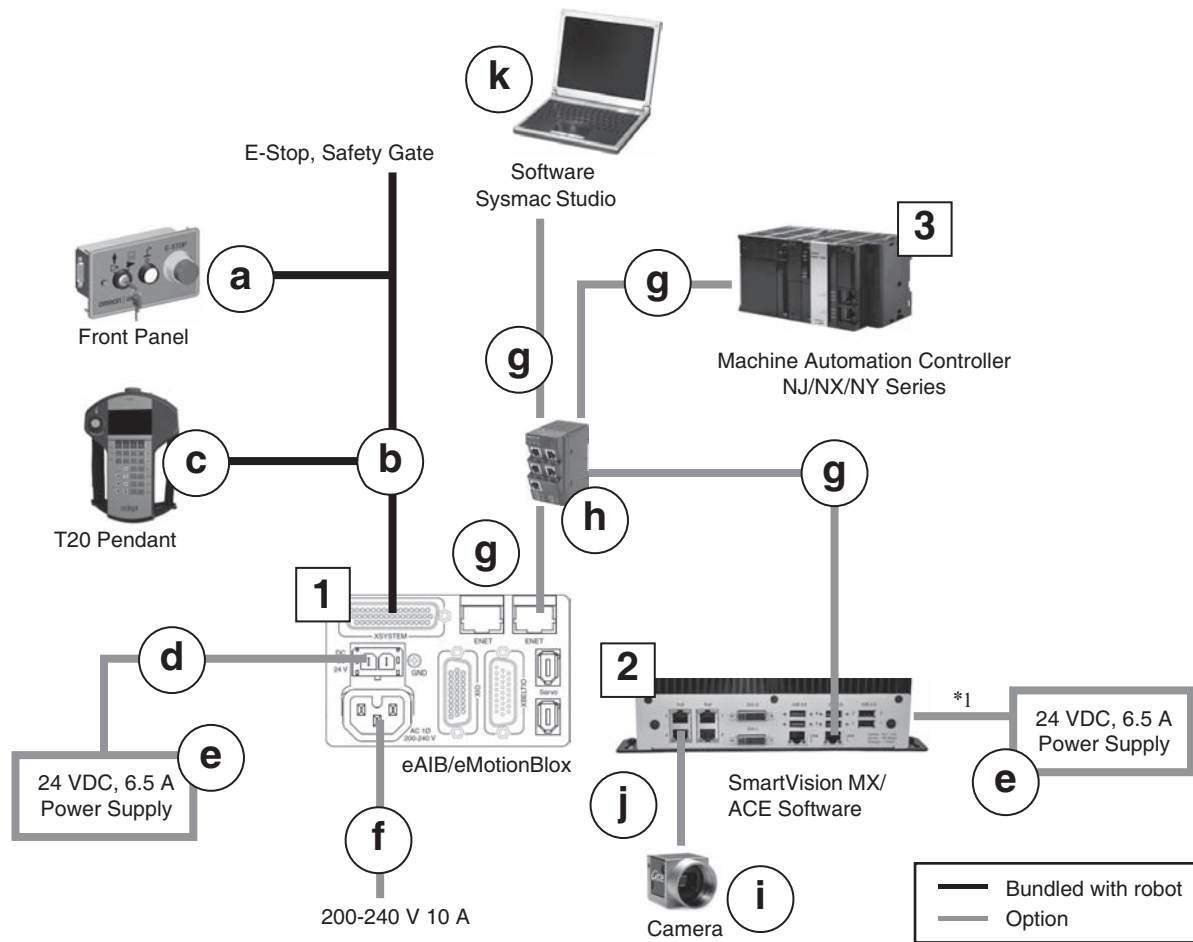

Cobra 450, eCobra, Viper, Hornet

Part	Name	Model	Note	Qty
1	Robot	17[]1-[] [] [] [] [] []		1
a	Front Panel with Cable *2	90356-10358	Bundled with Robot	(1)
b	eAIB XSYSTEM Cable	13323-000	Bundled with Robot	(1)
c	T20 Pendant with Cable	10046-010		1
d	24 VDC Power Cable	04120-000		1
e	24 VDC, 6.5 A Power Supply	S8FS-G15024C or S8FS-G15024D		2
f	AC Power Cable	04118-000		1
g	Ethernet Cable	XS6W-6LSZH8SS[] [] [] CM-Y		4
h	Industrial Switching Hubs	W4S1-05C		1
2	SmartVision MX	14189-901	Bundling a 24 VDC connector	1
i	Camera	241[] [] [] [] [] []		1 *3
j	Camera cable	---	Bundled with Camera	1 *3
3	Machine Automation Controller NJ/NX/NY Series	NJ/NX/NY		1
k	Automation software Sysmac Studio	SYSMAC-SE2[] [] []		1
---	ACE PackXpert with ACE Sight Vision License	09187-010		1

*1. User-supplied shielded power cable.

*2. The Front Panel is not included with the Cobra 450.

*3. Qty depends on system.

Connecting encoders

SmartController EX

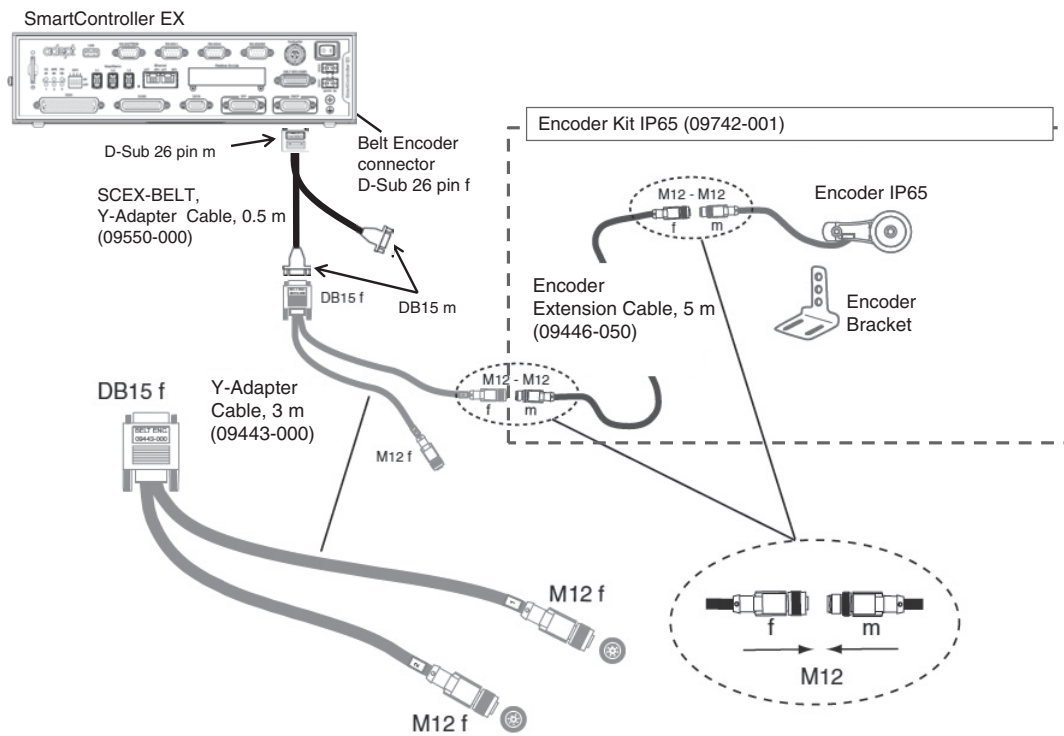

eAIB/eMotionBlox

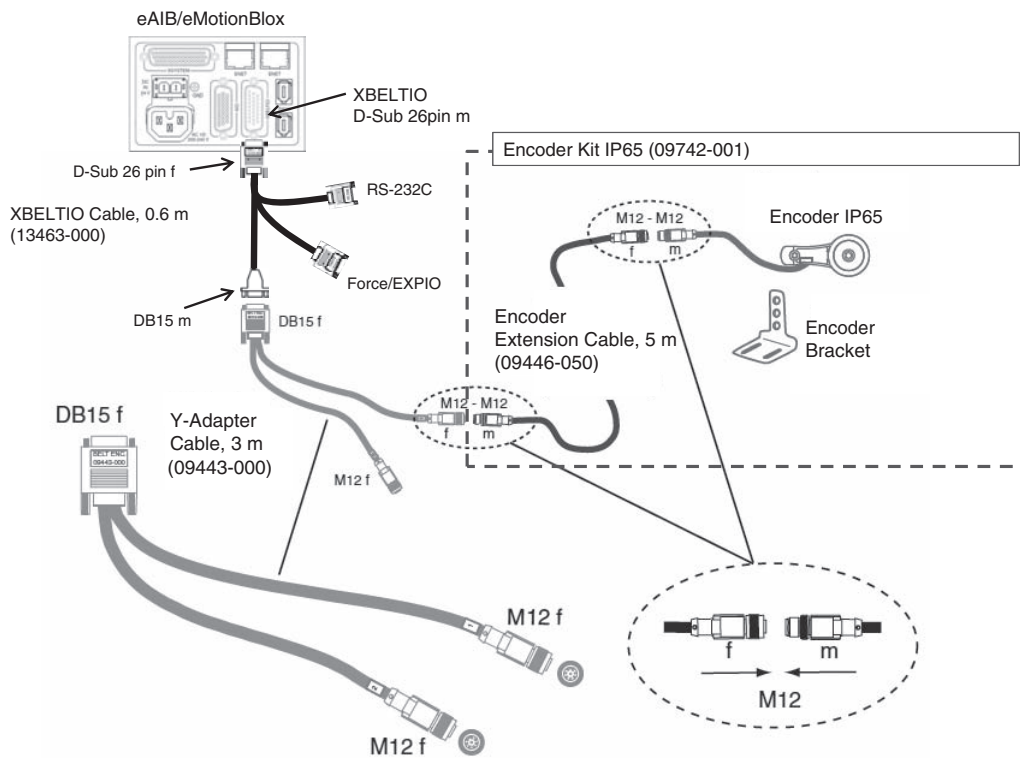

Connecting additional I/O options

■Connecting IO Blox (8 inputs, 8 outputs) to increase I/O ports

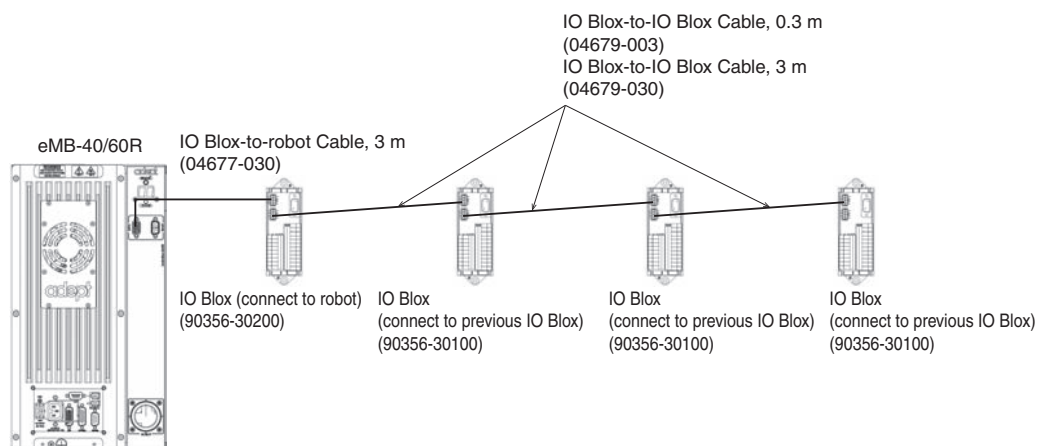
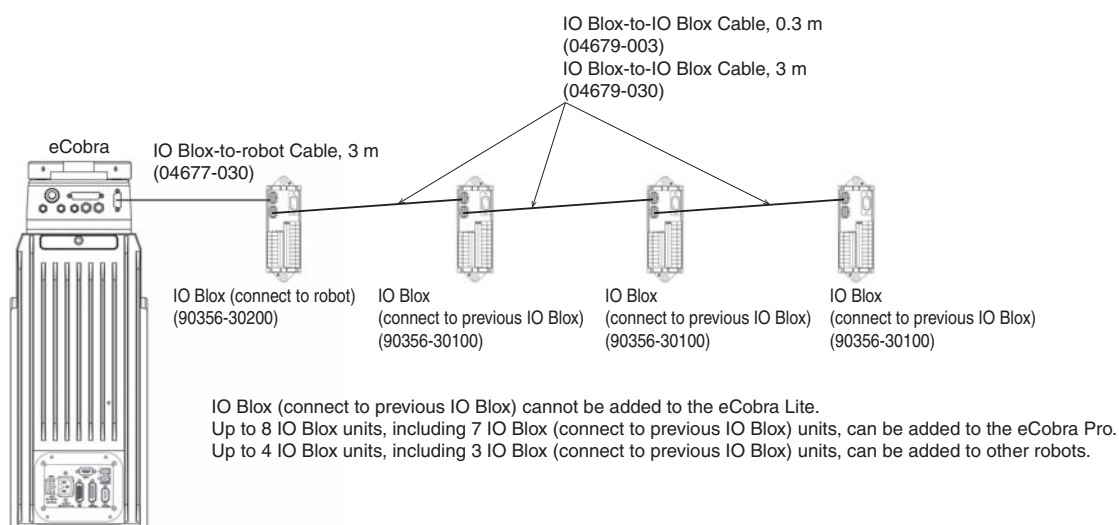

■Connecting XIO (12 inputs, 8 outputs) to increase I/O ports

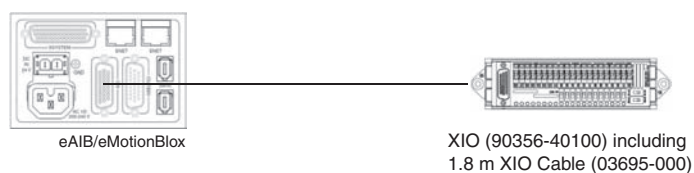

Protection and Cleanroom Classes

Type	Name	Specifications	Option	Remarks
Parallel Robots	Hornet 565	IP67: arms and platform IP65: underside of robot IP20: topside of robot Class 1000	IP65: topside of robot	The addition of the cable sealing kit raises the IP rating of the topside of the robot to IP65.
	Quattro 650H Quattro 800H	IP67: arms and platform Class 1000	IP65: underside of robot	The addition of the cable sealing kit raises the IP rating of the topside of the robot to IP65.
	Quattro 650HS Quattro 800HS	IP67: arms and platform IP66: robot base Class 1000	---	Mount the Cable Inlet Box (09564-000) on the topside of the robot.
SCARA Robots	Cobra 450	IP20	---	See pages 14 - 15 for model numbers.
	eCobra 600	IP20	Class10 Cleanroom model	See pages 16 - 17 for model numbers.
	eCobra 800 eCobra 800 Inverted	IP20	IP65, Class10 Cleanroom model	See pages 18 - 21 for model numbers.
Articulated Robots	Viper 650 Viper 850	IP40	IP54: robot main body IP65: robot joints (J4, J5, J6) Class10 Cleanroom model	See pages 22 - 25 for model numbers.

Ordering Information

Parallel Robots

Model Number Structure

Hornet

17 2 0 1 - 4 56 0 0

(1) (2) (3) (4) (5) (6) (7) (8)

No.	Item	Symbol	Specifications
(1)			Industrial Robots
(2)	Performance level	2	Pro
(3)	Version	0	
(4)	Configuration	1	Standard
		3	Add-On
(5)	Robot type	4	Hornet
(6)	Size	56	565 mm
(7)	Cleanroom/IP rating	0	Standard
		1	IP65/67
(8)	Options	0	3
		4	4

Quattro

17 2 1 4 - 2 60 0 0

(1) (2) (3) (4) (5) (6) (7) (8)

No.	Item	Symbol	Specifications
(1)			Industrial Robots
(2)	Performance level	2	Pro
(3)	Version	1	
(4)	Configuration	3	Add-On
		4	with EX Controller
(5)	Robot type	2	Quattro
(6)	Size	60	650 mm
		63	800 mm
(7)	Cleanroom/IP rating /HS	0	Standard
		1	HS
		2	IP65/67
(8)	Options	0	P30
		1	P31
		2	P32
		4	P34

Model Number List

Type	Model
Hornet 565 4Axis	17201-45604
Hornet 565 3Axis	17201-45600
Hornet 565 4Axis IP65/67	17201-45614
Hornet 565 3Axis IP65/67	17201-45610
Hornet 565 4Axis Add-On	17203-45604
Hornet 565 3Axis Add-On	17203-45600
Hornet 565 4Axis IP65/67 Add-On	17203-45614
Hornet 565 3Axis IP65/67 Add-On	17203-45610
Quattro 650H P30	17214-26000
Quattro 650H P31	17214-26001
Quattro 650H P32	17214-26002
Quattro 650H P34	17214-26004
Quattro 650H P30 IP65/67	17214-26020
Quattro 650H P31 IP65/67	17214-26021
Quattro 650H P32 IP65/67	17214-26022
Quattro 650H P34 IP65/67	17214-26024
Quattro 650HS P30	17214-26010
Quattro 650HS P31	17214-26011
Quattro 650HS P32	17214-26012
Quattro 650HS P34	17214-26014
Quattro 800H P30	17214-26300
Quattro 800H P31	17214-26301
Quattro 800H P32	17214-26302
Quattro 800H P34	17214-26304
Quattro 800HS P30	17214-26310
Quattro 800HS P31	17214-26311
Quattro 800HS P32	17214-26312
Quattro 800HS P34	17214-26314

Type	Model
Quattro 800H P30 IP65/67	17214-26320
Quattro 800H P31 IP65/67	17214-26321
Quattro 800H P32 IP65/67	17214-26322
Quattro 800H P34 IP65/67	17214-26324
Quattro 650H P30 Add-On	17213-26000
Quattro 650H P31 Add-On	17213-26001
Quattro 650H P32 Add-On	17213-26002
Quattro 650H P34 Add-On	17213-26004
Quattro 650HS P30 Add-On	17213-26010
Quattro 650HS P31 Add-On	17213-26011
Quattro 650HS P32 Add-On	17213-26012
Quattro 650HS P34 Add-On	17213-26014
Quattro 650H P30 IP65/67 Add-On	17213-26020
Quattro 650H P31 IP65/67 Add-On	17213-26021
Quattro 650H P32 IP65/67 Add-On	17213-26022
Quattro 650H P34 IP65/67 Add-On	17213-26024
Quattro 800H P30 Add-On	17213-26300
Quattro 800H P31 Add-On	17213-26301
Quattro 800H P32 Add-On	17213-26302
Quattro 800H P34 Add-On	17213-26304
Quattro 800HS P30 Add-On	17213-26310
Quattro 800HS P31 Add-On	17213-26311
Quattro 800HS P32 Add-On	17213-26312
Quattro 800HS P34 Add-On	17213-26314
Quattro 800H P30 IP65/67 Add-On	17213-26320
Quattro 800H P31 IP65/67 Add-On	17213-26321
Quattro 800H P32 IP65/67 Add-On	17213-26322
Quattro 800H P34 IP65/67 Add-On	17213-26324

Note: The purpose of this model number structure is to provide understanding of the meaning of specifications from the model number. Models are not available for all combinations of code numbers.

SCARA Robots

Model Number Structure

Cobra 450

17 2 0 1 - 1 45 0 0

(1) (2) (3) (4) (5) (6) (7) (8)

No.	Item	Symbol	Specifications
(1)	Industrial Robots		
(2)	Performance level	2	Pro
(3)	Version	0	
(4)	Configuration	1	Standard
		3	Add-On
(5)	Robot type	1	Cobra
(6)	Size	45	450 mm
(7)	Cleanroom/IP rating	0	Standard
(8)	Options	0	None

eCobra 600/800/800Inverted

17 0 1 0 - 1 60 0 0

(1) (2) (3) (4) (5) (6) (7) (8)

No.	Item	Symbol	Specifications
(1)	Industrial Robots		
(2)	Performance level	0	Lite
		1	Standard
		2	Pro
(3)	Version	1	
(4)	Configuration	0	ePLC not supported
		1	Standard
		3	Add-On
(5)	Robot type	1	eCobra
(6)	Size	60	600 mm
		80	800 mm
		84	800 mm Inverted
(7)	Cleanroom/IP rating	0	Standard
		1	Class 10
		3	IP65 (not available for 600 mm)
(8)	Options	0	None

Model Number List

Type	Model
Cobra 450	17201-14500
Cobra 450 Add-On	17203-14500
eCobra 600 Lite	17010-16000
eCobra 600 Standard	17111-16000
eCobra 600 Pro	17211-16000
eCobra 600 Lite Cleanroom	17010-16010
eCobra 600 Standard Cleanroom	17111-16010
eCobra 600 Pro Cleanroom	17211-16010
eCobra 800 Lite	17010-18000
eCobra 800 Standard	17111-18000
eCobra 800 Pro	17211-18000
eCobra 800 Lite Cleanroom	17010-18010
eCobra 800 Standard Cleanroom	17111-18010
eCobra 800 Pro Cleanroom	17211-18010
eCobra 800 Lite IP65	17010-18030
eCobra 800 Standard IP65	17111-18030
eCobra 800 Pro IP65	17211-18030
eCobra 800 Inverted Lite	17010-18400
eCobra 800 Inverted Standard	17111-18400
eCobra 800 Inverted Pro	17211-18400
eCobra 800 Inverted Lite Cleanroom	17010-18410
eCobra 800 Inverted Standard Cleanroom	17111-18410
eCobra 800 Inverted Pro Cleanroom	17211-18410

Type	Model
eCobra 800 Inverted Lite IP65	17010-18430
eCobra 800 Inverted Standard IP65	17111-18430
eCobra 800 Inverted Pro IP65	17211-18430
Cobra 450 Add-On	17203-14500
eCobra 600 Standard Add-On	17113-16000
eCobra 600 Pro Add-On	17213-16000
eCobra 600 Standard Cleanroom Add-On	17113-16010
eCobra 600 Pro Cleanroom Add-On	17213-16010
eCobra 800 Standard Add-On	17113-18000
eCobra 800 Pro Add-On	17213-18000
eCobra 800 Standard Cleanroom Add-On	17113-18010
eCobra 800 Pro Cleanroom Add-On	17213-18010
eCobra 800 Standard IP65 Add-On	17113-18030
eCobra 800 Pro IP65 Add-On	17213-18030
eCobra 800 Inverted Standard Add-On	17113-18400
eCobra 800 Inverted Pro Add-On	17213-18400
eCobra 800 Inverted Standard Cleanroom Add-On	17113-18410
eCobra 800 Inverted Pro Cleanroom Add-On	17213-18410
eCobra 800 Inverted Standard IP65 Add-On	17113-18430
eCobra 800 Inverted Pro IP65 Add-On	17213-18430

Note: The purpose of this model number structure is to provide understanding of the meaning of specifications from the model number. Models are not available for all combinations of code numbers.

Articulated Robots

Model Number Structure

Viper

17 2 0 1 - 3 60 0 0

(1) (2) (3) (4) (5) (6) (7) (8)

No.	Item	Symbol	Specifications
(1)	Industrial Robots		
(2)	Performance level	2	Pro
(3)	Version	0	
(4)	Configuration	1	Standard
		3	Add-On
(5)	Robot type	3	Viper
(6)	Size	60	650 mm
		80	850 mm
		84	800 mm Inverted
(7)	Cleanroom/IP rating	0	Standard
		1	IP54/65
		3	Class 10
(8)	Options	0	None

Model Number List

Type	Model
Viper 650	17201-36000
Viper 650 Cleanroom	17201-36020
Viper 650 IP54/65	17201-36010
Viper 850	17201-38000
Viper 850 Cleanroom	17201-38020
Viper 850 IP54/65	17201-38010
Viper 650 Add-On	17203-36000
Viper 650 Cleanroom Add-On	17203-36020
Viper 650 IP54/65 Add-On	17203-36010
Viper 850 Add-On	17203-38000
Viper 850 Cleanroom Add-On	17203-38020
Viper 850 IP54/65 Add-On	17203-38010

Note: The purpose of this model number structure is to provide understanding of the meaning of specifications from the model number.
Models are not available for all combinations of code numbers.

Options

Type	Name/Specifications	Model
Robot Controller	SmartController EX with Front Panel	19300-000
	SmartController EX (without Front Panel)	19200-000
Pendant	T20 Pendant with 10 m Cable	10046-010
	T20 Pendant-Jumper Plug	10048-000
	T20 Pendant Wall Bracket	10079-000
	T20 Adapter Cable, 3 m	10051-003
Sensor Controllers	SmartVision MX	14189-901
Camera	GigE PoE, 658 x 492 pixels, 120 fps, Color, CCD (1/4-inch equivalent), 10 m camera cables included	24114-101
	GigE PoE, 1296 x 966 pixels, 30 fps, Monochrome, CCD (1/3-inch equivalent), 10 m camera cables included	24114-200
	GigE PoE, 1294 x 964 pixels, 30 fps, Color, CCD (1/3-inch equivalent), 10 m camera cables included	24114-201
	GigE PoE, 1602 x 1202 pixels, 60 fps, Monochrome, CMOS (1/1.8-inch equivalent), 10 m camera cables included	24114-250
	GigE PoE, 1600 x 1200 pixels, 60 fps, Color, CMOS (1/1.8-inch equivalent), 10 m camera cables included	24114-251
	GigE PoE, 2048 x 2048 pixels, 25 fps, Monochrome, CMOS (1-inch equivalent), 10 m camera cables included	24114-300
	GigE PoE, 2046 x 2046 dots, 25 fps, Color, CMOS (1-inch equivalent), 10 m camera cables included	24114-301
Belt Encoder (Conveyor-Tracking)	Encoder Kit IP65	09742-001
	Y-Adapter Cable, 3 m	09443-000
	Encoder Extension Cable, 5 m	09446-050
	SCEX-BELT,Y-Adapter Cable, 0.5 m	09550-000
	XBELTIO Cable, 0.6 m	13463-000
Additional I/O Options	IO Blox (connect to robot), 8 inputs/8 outputs, 0.3 m cables included	90356-30200
	IO Block (connect to previous IO Blox), 8 inputs/8 outputs, 0.3 m cables included	90356-30100
	IO Blox-to-robot Cable, 3 m	04679-030
	IO Blox-to-IO Blox Cable, 0.3 m	04679-003
	IO Blox-to-IO Blox Cable, 3 m	04677-030
	Termination Block, 12inputs/8 outputs, cables included (1.8 m)	90356-40100
Front panel	Front Panel with 3 m cable	90356-10358
	Front Panel Cable, 3 m	10356-10500
Power Supply/Cable	AC Power Cable, 5 m	04118-000
	24 VDC Power Cable, 5 m	04120-000
	24 VDC, 6.5 A, 150 W (Front Mounting), Power Supply	S8FS-G15024C *1
	24 VDC, 6.5 A, 150 W (DIN-Rail Mounting), Power Supply	S8FS-G15024CD *1
	1394 Cable, 4.5 m	13632-045
	eAIB XSYSTEM Cable Assembly, 1.8 m	13323-000
	DB9 Splitter, 0.3 m	00411-000
	eAIB XSYS Cable, 4.5 m	11585-000
	Ethernet Cable	XS6W-6LSZH8SS[][][]CM-Y *2
Industrial Switching Hubs	W4S1-05C *3	
Solenoid Valve Kit	eCobra robots	02853-000
Cable Seal Kit	Hornet 565 IP65/67, Quattro 650HS IP65/67, Quattro 800HS IP65/67	08765-000
	Quattro 650HS Standard/Quattro 800HS Standard	09564-000
	eCobra 800 IP65/67	04813-000
	eCobra 800 Inverted IP65	09073-000
ACE License	Automation Control Environment (ACE)	Please download it from following URL: http://www.adept.com/Robots-Tool
	ACE PackXpert	09187-000
	ACE Sight Vision Software	01056-030
	ACE PackXpert with ACE Sight Vision This license contains an ACE PackXpert license and an ACE Sight license.	09187-010

Type	Name/Specifications	Model
Related Products	Machine Automation Controller NJ/NX/NY Series	NJ/NX/NY *4
	Automation Software Sysmac Studio	SYSMAC-SE2[] [] *4
	Collection of software functional components Sysmac Library Adept Robot Control Library	SYSMAC-XR009 *5

*1. Refer to the S8FS-G Switch Mode Power Supply DATASHEET (Cat.No.T207) for details.

*2. Refer to the Industrial Ethernet Cables Catalog (Cat.No.G019) for details.

*3. Refer to the Industrial Switching Hubs Catalog (Cat.No.V227) for details.

*4. Refer to the Sysmac Catalog (Cat.No.P072) for details.

*5. Refer to the Sysmac Library Catalog (Cat.No.P106) for details.

Related Documentation

Cat. No.	Manual
I590	Robot Safety Guide
I593	eCobra 600, 800, and 800 Inverted Robots User's Guide
I594	eCobra 600, 800, and 800 Inverted Robots ePLC Quick Setup Guide
I595	Hornet 565 Robot Quick Setup Guide
I596	Hornet 565 Robot User's Guide
I597	Quattro 650H/650HS/800H/800HS User's Guide
I598	Quattro 650H/650HS/800H/800HS ePLC Quick Setup Guide
I599	Viper 650/850 Robot with eMB-60R User's Guide
I600	Viper 650/850 ePLC Quick Setup Guide
I601	T20 Pendant User's Guide
I602	SmartController EX user's guide
I603	ACE User's Guide
I604	eV+ Language User's Guide
I605	eV+ Language Reference Guide
I606	eV+ Operating System User's Guide
I607	eV+ Operating System Reference Guide
I608	SmartVision MX User's Guide
I609	ACE Sight Reference Guide
I832	Cobra 450 Robot User's Guide

Terms and Conditions Agreement

Read and understand this catalog.

Please read and understand this catalog before purchasing the products. Please consult your OMRON representative if you have any questions or comments.

Warranties.

- (a) Exclusive Warranty. Omron's exclusive warranty is that the Products will be free from defects in materials and workmanship for a period of twelve months from the date of sale by Omron (or such other period expressed in writing by Omron). Omron disclaims all other warranties, express or implied.
- (b) Limitations. OMRON MAKES NO WARRANTY OR REPRESENTATION, EXPRESS OR IMPLIED, ABOUT NON-INFRINGEMENT, MERCHANTABILITY OR FITNESS FOR A PARTICULAR PURPOSE OF THE PRODUCTS. BUYER ACKNOWLEDGES THAT IT ALONE HAS DETERMINED THAT THE PRODUCTS WILL SUITABLY MEET THE REQUIREMENTS OF THEIR INTENDED USE.

Omron further disclaims all warranties and responsibility of any type for claims or expenses based on infringement by the Products or otherwise of any intellectual property right. (c) Buyer Remedy. Omron's sole obligation hereunder shall be, at Omron's election, to (i) replace (in the form originally shipped with Buyer responsible for labor charges for removal or replacement thereof) the non-complying Product, (ii) repair the non-complying Product, or (iii) repay or credit Buyer an amount equal to the purchase price of the non-complying Product; provided that in no event shall Omron be responsible for warranty, repair, indemnity or any other claims or expenses regarding the Products unless Omron's analysis confirms that the Products were properly handled, stored, installed and maintained and not subject to contamination, abuse, misuse or inappropriate modification. Return of any Products by Buyer must be approved in writing by Omron before shipment. Omron Companies shall not be liable for the suitability or unsuitability or the results from the use of Products in combination with any electrical or electronic components, circuits, system assemblies or any other materials or substances or environments. Any advice, recommendations or information given orally or in writing, are not to be construed as an amendment or addition to the above warranty.

See <http://www.omron.com/global/> or contact your Omron representative for published information.

Limitation on Liability; Etc.

OMRON COMPANIES SHALL NOT BE LIABLE FOR SPECIAL, INDIRECT, INCIDENTAL, OR CONSEQUENTIAL DAMAGES, LOSS OF PROFITS OR PRODUCTION OR COMMERCIAL LOSS IN ANY WAY CONNECTED WITH THE PRODUCTS, WHETHER SUCH CLAIM IS BASED IN CONTRACT, WARRANTY, NEGLIGENCE OR STRICT LIABILITY.

Further, in no event shall liability of Omron Companies exceed the individual price of the Product on which liability is asserted.

Suitability of Use.

Omron Companies shall not be responsible for conformity with any standards, codes or regulations which apply to the combination of the Product in the Buyer's application or use of the Product. At Buyer's request, Omron will provide applicable third party certification documents identifying ratings and limitations of use which apply to the Product. This information by itself is not sufficient for a complete determination of the suitability of the Product in combination with the end product, machine, system, or other application or use. Buyer shall be solely responsible for determining appropriateness of the particular Product with respect to Buyer's application, product or system. Buyer shall take application responsibility in all cases.

NEVER USE THE PRODUCT FOR AN APPLICATION INVOLVING SERIOUS RISK TO LIFE OR PROPERTY OR IN LARGE QUANTITIES WITHOUT ENSURING THAT THE SYSTEM AS A WHOLE HAS BEEN DESIGNED TO ADDRESS THE RISKS, AND THAT THE OMRON PRODUCT(S) IS PROPERLY RATED AND INSTALLED FOR THE INTENDED USE WITHIN THE OVERALL EQUIPMENT OR SYSTEM.

Programmable Products.

Omron Companies shall not be responsible for the user's programming of a programmable Product, or any consequence thereof.

Performance Data.

Data presented in Omron Company websites, catalogs and other materials is provided as a guide for the user in determining suitability and does not constitute a warranty. It may represent the result of Omron's test conditions, and the user must correlate it to actual application requirements. Actual performance is subject to the Omron's Warranty and Limitations of Liability.

Change in Specifications.

Product specifications and accessories may be changed at any time based on improvements and other reasons. It is our practice to change part numbers when published ratings or features are changed, or when significant construction changes are made. However, some specifications of the Product may be changed without any notice. When in doubt, special part numbers may be assigned to fix or establish key specifications for your application. Please consult with your Omron's representative at any time to confirm actual specifications of purchased Product.

Errors and Omissions.

Information presented by Omron Companies has been checked and is believed to be accurate; however, no responsibility is assumed for clerical, typographical or proofreading errors or omissions.

Note: Do not use this document to operate the Unit.

OMRON Corporation Industrial Automation Company
Kyoto, JAPAN

Contact: www.ia.omron.com

Regional Headquarters

OMRON EUROPE B.V.

Wegalaan 67-69, 2132 JD Hoofddorp
The Netherlands
Tel: (31)2356-81-300/Fax: (31)2356-81-388

OMRON ASIA PACIFIC PTE. LTD.

No. 438A Alexandra Road # 05-05/08 (Lobby 2),
Alexandra Technopark,
Singapore 119967
Tel: (65) 6835-3011/Fax: (65) 6835-2711

OMRON ELECTRONICS LLC

2895 Greenspoint Parkway, Suite 200 Hoffman Estates,
IL 60169 U.S.A.
Tel: (1) 847-843-7900/Fax: (1) 847-843-7787

OMRON ADEPT TECHNOLOGIES, INC.

4550 Norris Canyon Road, Suite 150, San Ramon, CA 94583 U.S.A.
Tel: (1) 925-245-3400/Fax: (1) 925-960-0590

OMRON (CHINA) CO., LTD.

Room 2211, Bank of China Tower, 200 Yin Cheng Zhong Road,
PuDong New Area, Shanghai, 200120, China
Tel: (86) 21-5037-2222/Fax: (86) 21-5037-2200

Authorized Distributor:

© OMRON Corporation 2016-2018 All Rights Reserved.
In the interest of product improvement,
specifications are subject to change without notice.

CSM_7_4_0518

Cat. No. I822-E1-06

0518(0316)