

Closed-loop Stepper Motor Driver

AiC-D Series

INSTRUCTION MANUAL

TCD210118AA

Autonics

Thank you for choosing our Autonics product.

Read and understand the instruction manual and manual thoroughly before using the product.

For your safety, read and follow the below safety considerations before using.

For your safety, read and follow the considerations written in the instruction manual, other manuals and Autonics website.

Keep this instruction manual in a place where you can find easily.

The specifications, dimensions, etc. are subject to change without notice for product improvement. Some models may be discontinued without notice.

Follow Autonics website for the latest information.

Safety Considerations

- Observe all 'Safety Considerations' for safe and proper operation to avoid hazards.
- ⚠ symbol indicates caution due to special circumstances in which hazards may occur.

⚠ Warning Failure to follow instructions may result in serious injury or death.

- Fail-safe device must be installed when using the unit with machinery that may cause serious injury or substantial economic loss. (e.g. nuclear power control, medical equipment, ships, vehicles, railways, aircraft, combustion apparatus, safety equipment, crime / disaster prevention devices, etc.)**
Failure to follow this instruction may result in personal injury, economic loss or fire.
- Do not use the unit in the place where flammable / explosive / corrosive gas, high humidity, direct sunlight, radiant heat, vibration, impact or salinity may be present.**
Failure to follow this instruction may result in explosion or fire.
- Do not connect, repair, or inspect the unit while connected to a power source.**
Failure to follow this instruction may result in fire or electric shock.
- Install the unit after considering counter plan against power failure.**
Failure to follow this instruction may result in personal injury, economic loss or fire.
- Check 'Connections' before wiring.**
Failure to follow this instruction may result in fire.
- Do not disassemble or modify the unit.**
Failure to follow this instruction may result in fire or electric shock.
- Install the driver in the housing or ground it.**
Failure to follow this instruction may result in personal injury, fire or electronic shock.
- Do not touch the unit during or after operation for a while.**
Failure to follow this instruction may result in burn or electric shock due to high temperature of the surface.
- Emergency stop directly when error occurs.**
Failure to follow this instruction may result in personal injury or fire.

⚠ Caution Failure to follow instructions may result in injury or product damage.

- When connecting the power input, use AWG18 (0.75 mm²) cable or over.**
- Brake is non-polar. When connecting the brake, use AWG24 (0.2 mm²) cable or over.**
Failure to follow this instruction may result in fire or malfunction due to contact failure.
- To use the motor safely, do not apply external force to the motor.**
- It is recommended to use STOPPER for the vertical load.**
- Install over-current prevention device (e.g. the current breaker, etc.) to connect the driver with power.**
Failure to follow this instruction may result in fire.
- Check the control input signal before supplying power to the driver.**
Failure to follow this instruction may result in personal injury or product damage by unexpected driver movement.
- Install a safety device to maintain the vertical position after turn off the power of this driver.**
Failure to follow this instruction may result in personal injury or product damage by releasing holding torque of the motor.
- Use the unit within the rated specifications.**
Failure to follow this instruction may result in fire or product damage.
- Use a dry cloth to clean the unit, and do not use water or organic solvent.**
Failure to follow this instruction may result in fire or electric shock.
- The driver may overheat depending on the environment. Install the unit at the well-ventilated environment and forced cooling with a cooling fan.**
Failure to follow this instruction may result in product damage or degradation by heat.
- Keep the product away from metal chip, dust, and wire residue which flow into the unit.**
Failure to follow this instruction may result in fire or product damage.
- Use the designated motor only.**
Failure to follow this instruction may result in fire or product damage.

Cautions during Use

- Follow instructions in 'Cautions during Use'. Otherwise, it may cause unexpected accidents.
- Power supply should be insulated and limited voltage/current or Class 2, SELV power supply device.
- Re-supply power after 1 sec from disconnected power.
- In case of unwanted noise generating from peripherals and power, use ferrite core in the wiring.
- Using USB type 485 converter may cause unstable communication. It is recommended to use 485 converter with separated power. (Autonics product SCM-38I is recommended.)
- The thickness of cable should be same or thicker than the below specifications when connecting the cable for connector.
 - Power connector: AWG18
 - Motor + Encoder connector: AWG22, AWG24
 - I/O connector: AWG28
- Keep the distance between power cable and signal cable over 10 cm.
- Motor vibration and noise may occur in a specific frequency range.
 - Change the motor installation method or attach the damper.
 - Use the unit out of the corresponding frequency range due to changing motor RUN speed.
- Maintain and inspect regularly the following lists.
 - Unwinding bolts and connection parts for the unit installation and load connection
 - Abnormal sound from ball-bearing of the unit
 - Damage and stress of lead cable of the unit
 - Connection error with motor
 - Inconsistency between the axis of motor output and the center, concentric (eccentric, declination) of the load, etc.
- This product does not contain a protection function for a motor unit.
- This unit may be used in the following environments.
 - Indoors (in the environment condition rated in 'Specifications')
 - Altitude max. 2,000 m
 - Pollution degree 2
 - Installation category II

Manual

For proper use of the product, refer to the manuals and be sure to follow the safety considerations in the manuals.

Download the manuals from the Autonics website.

Software

Download the installation file and the manuals from the Autonics website.

■ atMotion

The program allows to manage the motor driver's parameter setting and monitoring data.

Ordering Information

This is only for reference, the actual product does not support all combinations..

For selecting the specified model, follow the Autonics website.

Select a model that matches the ordering information of the motor and the driver.

AiC	-	D	-	①	②	③	-	④
------------	----------	----------	----------	----------	----------	----------	----------	----------

① Frame size

Number: Frame size (Unit: mm)

	□ 20 / 28 / 35 mm	□ 42 / 56 / 60 mm
A	4,000 PPR (1,000 PPR × 4)	10,000 PPR (2,500 PPR × 4)
B	16,000 PPR (4,000 PPR × 4)	-

② Axial length

S: Short

M: Medium

L: Long

③ Encoder resolution

	□ 20 / 28 / 35 mm	□ 42 / 56 / 60 mm
A	4,000 PPR (1,000 PPR × 4)	10,000 PPR (2,500 PPR × 4)
B	16,000 PPR (4,000 PPR × 4)	-

④ Motor type

No mark: Standard type

B: Built-in brake type

Product Components

- Product
- Instruction manual
- RS485 comm. protective connector
- Power connector
- I/O connector
- Brake connector (AiC-D-B Series)

Sold Separately

- Power cable: CJ-PW-□
- Motor + Encoder cable: C1D14M-□ (fixed type), C1DF14M-□ (flexible type)
- I/O Cable: CO50-MP□-R (specifications: AiC TAG)

Dimensions

- Unit: mm, For the detailed drawings, follow the Autonics website.

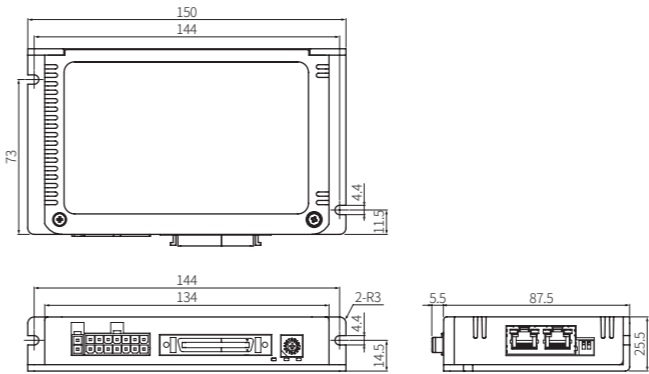

Unit Descriptions

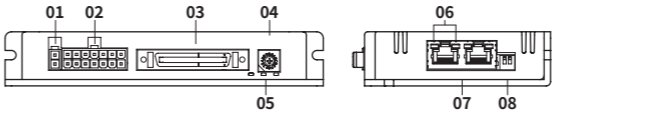

01. Power connector

02. Motor + Encoder connector

03. I/O connector

04. Comm. ID setting rotary switch

05. Status indicator

06. RS485 comm. indicator

07. RS485 comm. connector

08. Comm. ID setting / Terminating resistance DIP switch

Status Indicators

Indicator	Color	Descriptions
Servo ON / OFF Indicator (SERVO)	Orange	Turns ON when servo is ON, Turns OFF when servo is OFF
In-Position Indicator (INP.)	Yellow	Turns ON when motor is placed at command position after positioning input
Power / Warning Indicator (PWR)	Green	Turns ON when the unit operates in normal after power is applied Flashes depending on the warning type
Alarm Indicator (AL)	Red	Flashes depending on the alarm type
RS485 Communication Indicator (RXD IN)	Yellow	Flashes when receiving data
RS485 Communication Indicator (TXD OUT)	Green	Flashes when transmitting data

Alarm / Warning

Depending on the alarm type, it flashes for 0.4 sec interval and it turns OFF for 0.8 sec repeatedly.

■ Alarm

No. of flashing	Alarm type	No. of flashing	Alarm type
1	Overcurrent error	10	Command speed error
2	Overspeed error	11	Input voltage error
3	Position tracking error	12	In-Position error
4	Overload error	13	Memory error
5	Overheat error	14	Emergency stop
6	Motor connection error	15	Program mode error
7	Encoder connection error	16	Index mode error
8	Regenerative voltage error	17	Home search mode error
9	Motor alignment error	-	

■ Warning

No. of flashing	Warning type
1	+Software limit
2	-Software limit
3	+Hardware limit
4	-Hardware limit
5	Overload warning
6	Override warning

Specifications

Model	AiC-D-20□A	AiC-D-28□B	AiC-D-35□B
Power supply	24 VDC≒ ±10%		
Max. RUN power ⁰¹⁾	≤ 60 W		
Stop power ⁰²⁾	≤ 10 W		
Max. RUN current ⁰³⁾	0.6 A / Phase	1.0 A / Phase	1.2 A / Phase
Stop current	20 to 100% of max. RUN current (factory default: 50%)		
Resolution	500 (factory default), 1000, 1600, 2000, 3600, 4000, 5000, 6400, 7200, 10000 PPR	500 (factory default), 1000, 1600, 2000, 3200, 3600, 5000, 6400, 7200, 10000 PPR	

Model	AiC-D-42□A-□	AiC-D-56□A-□	AiC-D-60□A-□
Power supply	24 VDC≒ ±10%		
Max. RUN power ⁰¹⁾	≤ 60 W	≤ 120 W	≤ 240 W
Stop power ⁰²⁾	≤ 10 W	≤ 12 W	≤ 15 W
Max. RUN current ⁰³⁾	1.7 A / Phase	3.5 A / Phase	
Stop current	20 to 100% of max. RUN current (factory default: 50%)		
Resolution	500 (factory default), 1000, 1600, 2000, 3200, 3600, 5000, 6400, 7200, 10000 PPR		

01) When changing the load rapidly, instantaneous peak current may increase. The capacity of power supply should be over 1.5 to 2 times of max. RUN power.

02) Based on ambient temp. 25°C, ambient humi. 55%RH, stop current 50%

03) RUN current varies depending on the input RUN frequency and max. RUN current at the moment varies also.

Run method	2-phase bipolar closed-loop control method
Speed filter	Disable, 2, 4, 6, 8, 10, 20, 40, 60 (factory default), 80, 100, 120, 140, 160, 180, 200 ms
Control Gain	0 (factory default) ~ 14, Fine Gain
Max. rotation speed	3000 rpm
Positioning range	-2,147,483,648 to +2,147,483,647
In-Position	Fast Response: 0 (factory default) to 7, Accurate Response: 0 to 7
Rotation direction	CW (factory default), CCW
Operation mode	Jog mode, Continuous mode, Index mode, Program mode
Home search mode	General mode, Limit mode, Zero point mode, Torque mode
Index step	64 step
Program step	256 step
Program function	Power On Program Start, Power On Home Search
Control command	ABS, INC, HOM, ICJ, IRD, OPC, OPT, JMP, REP, RPE, END, POS, TIM, CMP

I/O voltage level	[H]: 5 - 30 VDC≒, [L]: 0 - 2 VDC≒
Input ⁰¹⁾	Exclusive input: 20, General input: 9
Output	Standard type - Exclusive output: 4, General output: 10 Built-in brake type - Exclusive output: 6, General output: 9
External power supply	VEX (recommended: 24 VDC≒): 2, GEX (GND): 2
Insulation resistance	≥ 100 MΩ (500 VDC≒ megger)
Dielectric strength	1,000 VAC~ 60 Hz for 1 minute
Vibration	1.5 mm double amplitude at frequency 10 to 55 Hz (for 1 minute) in each X, Y, Z direction for 2 hours
Shock	300 m/s ² (≈ 30 G) in each X, Y, Z direction for 3 times
Ambient temp.	0 to 50°C, storage: -10 to 60°C (no freezing or condensation)
Ambient humi.	35 to 85%RH, storage: 10 to 90%RH (no freezing or condensation)
Protection rating	IP20 (IEC standard)
Approval	CE ENEC
Unit weight (packaged)	≈ 300 g (≈ 460 g)

01) Brake ON/OFF function can be changed from general input IN8 in case of built-in brake type.

Communication Interface

■ RS485

Comm. protocol	Modbus RTU
Applied standard	Compliance with EIA RS485
Max. connections	31 units (address: 01 to 31)
Synchronous method	Asynchronous
Comm. method	2-wire half duplex
Comm. distance	≤ 800 m
Baud rate	9600, 19200, 38400, 57600, 115200 (factory default) bps
Start bit	1 bit (fixed)
Data bit	8 bit (fixed)
Parity bit	None (factory default), Even, Odd
Stop bit	1 bit (factory default), 2 bit

Troubleshooting

Malfunction	Causes	Troubleshooting
When communication is not connected	The communication cable is not connected. The communication port or speed settings are not correct.	Check communication cable wiring. Check communication cable connected correctly. Check communication port and speed settings are correct.
When motor does not excite	Servo is not ON. Alarm occurs.	Check that Servo ON/OFF input signal is OFF. In case of ON, servo is OFF and excitation of motor is released. Check the alarm type and remove the cause.
When motor rotates to the opposite direction of the designated direction	MotorDir parameter setting is not correct.	Check the MotorDir parameter settings.
When motor drives unstable	Connection between motor and encoder is unstable. Control Gain value is not correct.	Check the driver and motor are connected correctly. Change the Control Gain parameter as the appropriate value.