

Long Range Laser Distance Sensor  
HG-F1 Series  
**User's Manual**

---

(MEMO)

## Introduction

Thank you for purchasing an **HG-F1** series long distance laser ranging sensor.

Before using this product, read and understand this User's Manual. Use the product correctly and in the optimum manner.

Keep this manual in a safe location for reference whenever necessary.

## Manual Configuration

Chapter 1	Before Using This Product	This chapter explains safety and handling precautions, laser safety standards, component names, and other information that should be checked before using this product.
Chapter 2	System Configuration	This chapter explains the system configuration.
Chapter 3	Installation and Connection	This chapter explains installation, connection, wiring, and other work.
Chapter 4	Basic Settings	This chapter explains how to perform basic operations and check operations before starting detection.
Chapter 5	Setting Items and Setting Methods	This chapter explains details and settings for various functions.
Chapter 6	Maintenance	This chapter explains maintenance and inspection.
Chapter 7	Troubleshooting	This chapter explains how to take action when problems occur.
Chapter 8	Specifications and Dimensions	This chapter explains the specifications and dimensions.

(MEMO)

# Table of Contents

<b>1 Before Using This Product</b> .....	<b>1-1</b>
1.1 Safety Precautions (Always observe) .....	1-2
1.2 Handling Precautions.....	1-3
1.3 Terminology.....	1-7
1.4 Open Source Software (OSS).....	1-8
1.4.1 Copyright·License .....	1-9
1.5 Regulations and Standards .....	1-12
1.6 Laser Safety Standards .....	1-13
1.6.1 IEC / JIS / GB / KS.....	1-13
1.6.2 FDA.....	1-14
1.7 Contents of Package.....	1-16
<b>2 System Configuration</b> .....	<b>2-1</b>
2.1 Principle of Measurement .....	2-2
2.2 Description of Parts.....	2-3
<b>3 Installation and Connection</b> .....	<b>3-1</b>
3.1 Installation Method.....	3-2
3.2 Wiring Connection Diagram .....	3-4
3.3 Adjusting the beam axis.....	3-5
<b>4 Basic Settings</b> .....	<b>4-1</b>
4.1 Basic Setup Procedure .....	4-2
4.1.1 Flow of Operations up to Setup Completion .....	4-2
4.1.2 Emitted Beam Spot Check Mode .....	4-4
4.1.3 2-point Teaching (Normal Sensing Mode).....	4-5
4.2 Operation Check .....	4-7
<b>5 Setting Items and Setting Methods</b> .....	<b>5-1</b>
5.1 List of Setting Items .....	5-2
5.2 Threshold Fine Adjustment.....	5-6
5.3 Threshold Selectable .....	5-7
5.4 Peak / Bottom Hold Function .....	5-9
5.5 Zero Set Function .....	5-10
5.5.1 Zero Set Setting .....	5-10
5.5.2 Zero Set Clearing .....	5-11
5.6 Key Lock Function .....	5-13
5.6.1 Key Lock Setting .....	5-13
5.6.2 Key Lock Release .....	5-13
5.7 Response Time Setting.....	5-15
5.8 Output Operation Setting .....	5-16

5.9 Sensing Output Setting (Teaching) .....	5-17
5.9.1 Normal Sensing Mode .....	5-18
5.9.2 Window Comparator Mode .....	5-21
5.10 Analog Output Setting .....	5-27
5.11 Analog Scaling Setting .....	5-28
5.12 Hysteresis Setting .....	5-32
5.13 Shift Amount Setting .....	5-33
5.14 External Input Setting.....	5-34
5.14.1 Zero Setting .....	5-34
5.14.2 Teaching.....	5-35
5.14.3 Emission Stop .....	5-35
5.15 Timer Setting.....	5-37
5.16 Timer Time Setting.....	5-40
5.17 Hold Setting .....	5-41
5.18 ECO Setting .....	5-43
5.19 Reset Setting .....	5-44
<b>6 Maintenance .....</b>	<b>6-1</b>
6.1 Maintenance and Inspection .....	6-2
6.1.1 Maintenance Precautions .....	6-2
6.1.2 Main Inspection Items .....	6-2
<b>7 Troubleshooting .....</b>	<b>7-1</b>
7.1 Solutions to Problems .....	7-2
7.2 Error Display .....	7-3
<b>8 Specifications and Dimensions .....</b>	<b>8-1</b>
8.1 Specifications.....	8-2
8.2 Shapes and Dimensions .....	8-5
8.2.1 Products.....	8-5
8.2.2 Simple Mounting Bracket ( <b>MS-HG-01: Including two M3 screws with washer</b> ).....	8-6
8.2.3 Simple Mounting Bracket Attachment Diagram .....	8-7
8.3 I/O Circuit Diagrams.....	8-8
<b>Appendix Screen Transition List .....</b>	<b>App-1</b>
Screen Transition List .....	App-2

# 1 Before Using This Product

---

1.1 Safety Precautions (Always observe) .....	1-2
1.2 Handling Precautions.....	1-3
1.3 Terminology.....	1-7
1.4 Open Source Software (OSS).....	1-8
1.4.1 Copyright·License .....	1-9
1.5 Regulations and Standards .....	1-12
1.6 Laser Safety Standards .....	1-13
1.6.1 IEC / JIS / GB / KS.....	1-13
1.6.2 FDA.....	1-14
1.7 Contents of Package.....	1-16



## 1.1 Safety Precautions (Always observe)









---

### 1.1 Safety Precautions (Always observe)

This section explains important rules that must be observed to prevent personal injury and property damage.

- **Safety precautions items are classified into “WARNING” and “CAUTION” depending on the level of hazard.**





 <b>WARNING</b>	Risk of death or serious injury.
 <b>CAUTION</b>	Risk of minor injury or property damage.

 <b>WARNING</b>	
	<ul style="list-style-type: none"><li>• Do not use this product as a sensing device for personal protection. Using this product as a sensing device for personal protection may result in death or serious injury.</li></ul>
	<ul style="list-style-type: none"><li>• For sensing devices for personal protection, use products that conform to the laws and standards related to personal protection in each country, such as OSHA, ANSI, and IEC.</li></ul>
	<ul style="list-style-type: none"><li>• This product is intended to be used to detect target objects and is not provided with control functions that prevent accidents to ensure safety.</li></ul>
	<ul style="list-style-type: none"><li>• Avoid observing beams in a dark surrounding environment.</li></ul>
	<ul style="list-style-type: none"><li>• Do not stare into laser beam with an optical device such as telephoto optics.</li></ul>
	<ul style="list-style-type: none"><li>• Never attempt to disassemble, repair, or modify this product.</li></ul>
	<ul style="list-style-type: none"><li>• Controlling or adjusting the product according to procedures other than those specified in this User's Manual may lead to dangerous exposure to laser radiation.</li></ul>



## 1.2 Handling Precautions

- In this manual, the following symbols are used to indicate safety information that must be observed.

	Indicates an action that is prohibited or a matter that requires caution.
	Indicates an action that must be taken.
	Indicates supplemental information.
	Indicates details about the subject in question or information useful to remember.
	Indicates operation procedures.

### ■ Handling precautions

#### Specifications

- This product has been developed and manufactured for industrial use only.
- Do not use this product outside the scope of the specifications. Doing so may result in accidents or failures.  
It will also significantly shorten the service life.
- There is a certain deviation in the directivity of this product. When using this product, install the product using a mounting bracket or similar fitting to allow the adjustment of beam axis.
- The internal memory (non-volatile memory) of this product has a service life. Settings cannot be configured more than one million times.
- Due to leak light around the detection point, the measurement values may be affected if there exist objects with high reflectance around the detecting point.
- If specular reflection light enters the beam receiving part, proper measurement may not be possible. When the reflectance of a detection object is high, be careful in installation.
- Do not perform wiring or maintenance with wet hands. Doing so may cause an electric shock.

#### Power supply

- Verify that the supply voltage fluctuations are within the rating when using the product. Note that applying a voltage greater than the rated voltage or directly applying AC power will result in damage or burning.
- To ensure performance, use the product at least 30 minutes (warm-up time) after the power is turned ON.
- If power is supplied from a commercial switching regulator, ensure that the frame ground (F.G.) terminal of the power supply is connected to an actual ground.
- Make sure that the power supply input satisfies the following items.
  1. The power supply unit must be certified for use in your region
  2. The output holding time of the power supply unit must be 20 ms or more
  3. The power supply unit must have the rated output voltage of 24 VDC  $\pm$  10 % and the ripple (P/P) of 0.5 V or less, and current capacity of 0.5 A or more.
  4. The power supply unit with SELV (Safety Extra Low Voltage) or PELV (Protective Extra Low Voltage) that comply with the EMC Directive must be used (if the CE marking compliance is required).

## 1.2 Handling Precautions

---

5. The power supply unit with SELV (Safety Extra Low Voltage) or PELV (Protective Extra Low Voltage) that comply with the EMC Regulations must be used (if the UKCA marking compliance is required).
  6. The power supply unit must support Class 2 (if cTÜVus marking compliance is required).
- If surges occur, take countermeasures such as connecting a surge absorber to the source of the surges.
  - If large noise is generated in the power supply line, the analog output is affected. In that case, use a noise filter or noise cut transformer.
  - When using a transformer in the power supply line, be sure to use an isolation transformer. If an autotransformer is used, this product or power supply may be damaged.
  - To protect the system against erroneous voltage from the power supply line, use an insulated power supply with an internal protective circuit.
  - If using a power supply unit without a protective circuit, be sure to supply power via a protective element such as a fuse.
  - Have the power supply sequence such that the power supply of the sensor turns ON before the power supply for the input and output.
  - Have the power supply sequence such that the power supply for the input and output turns OFF before the power supply of the sensor.
  - After turning OFF the power supply of the sensor, wait for at least ten seconds before turning ON the power supply.
  - After the power is turned ON, the starting up operation before reaching the operation status is unstable. During the starting up operation, all the outputs are not determined yet, so do not use those outputs.
  - Never turn OFF the power supply in the middle of saving the settings such as teaching or PRO mode settings. In the worst case, the memory in the sensor may be damaged and restarting may not be possible.
  - Depending on the instantaneous power failure time, there are cases where the operation is continued or where the operation is reset to the initial state as when the power is turned ON. Do not use the product in an environment where instantaneous power failure may occur.

### Wiring

- Before wiring work, always turn the power off.
- Do not wire in parallel with a high-voltage line or power line, or run through the same conduit. Doing so may result in malfunctioning due to induction.
- Apply a load so that a current of 50 mA or more does not flow through the control output line. Also avoid incorrect wiring such as polarity connection error of the power supply. Failure to do so may cause damage or burning.
- The overall length of the cable can be extended to 10 m maximum with a cable size of 0.3 mm<sup>2</sup> or more. Use a shielded cable to extend the analog wire line.
- Avoid wiring the sensor cable together with other wiring (bundling in parallel) and, instead, separate the sensor cable from other wiring as much as possible. Also, separate the sensor cable from high voltage circuit or power circuit. If unavoidable, shield the sensor cable with conductor such as a grounded conduit.
- For signal lines such as I/O terminals, it is recommended to use a shielded cable to prevent noise.
- Separate the input signal line and output signal line from the power line and power supply line as much as possible. Furthermore, make each line as short as possible for connecting various signal lines.

- Use shielded cables for analog output and make the line as short as possible because it is particularly liable to be affected by an external noise.
- Install the product as much as possible away from high-voltage lines, high-voltage devices, power lines, power devices, devices with large switching surges, welders, inverter motors and other noise generation sources.
- Do not apply stress such as excessive bending or pulling to the extracted part of a cable.

### Operating environment

- This product is suitable for indoor use only.
- Do not install the sensor in the following locations.
  - Locations subject to flammable gas, corrosive gas, or excessive dust
  - Locations subject to water drops
  - Locations subject to dust, metal particles, or saline matter
  - Atmospheres containing benzene, paint thinner, alcohol, or other organic solvents or strong alkaline substances such as ammonia or caustic soda
  - Locations subject to severe vibration or shock
  - Locations subject to direct sunlight
  - Locations subject to water, oil, or chemicals
  - Locations where load is applied to the sensor
- Use the product in an environment where the temperature ranges between -10 °C and +45 °C. Also, store the product in an environment where the temperature ranges between -20 °C and +60 °C. However, avoid using the product in an environment where icing may occur.
- Use the product in an environment where the humidity ranges between 35% RH and 85% RH. Also, store the product in an environment where the humidity ranges between 35% RH and 85% RH. However, avoid using or storing the product in an environment where dew condensation may occur due to a sudden temperature change.
- Use the product with illuminance of 3,000 lx or less on the light receiving surface of an incandescent lamp.
- Do not use the product in a location where the ambient temperature, ambient humidity, and illuminance on the light receiving surface exceed the operating environment ranges.
- Avoid using this product in environments where condensation occurs due to sudden temperature change.
- The service life of a semiconductor laser depends on the ambient operating temperature. When using the product near a heat generation part, lower the ambient temperature as much as possible by cooling, etc.
- Since the sensor itself generates heat, install the sensor on a material with good heat radiation.
- Performance may not be satisfactory in a strong electromagnetic field.
- Do not allow extraneous light such as sunlight or other light that has the same wavelength as the laser to directly hit the beam receiving part. In particular, if precision is required, use this product by mounting a douser or similar material.
- Keep the light emitting and receiving windows of this product clean and free of water, oil, fingerprints, and other substances that refract light as well as dust, grit, and other objects that intercept light. When cleaning the surfaces, wipe them with a lint-free soft cloth or lens cleaning paper.
- Make sure to turn OFF the power supply before cleaning the light emitting and receiving windows of this product.
- This product is a precision device. Do not drop or otherwise subject to shock. Doing so may cause product failure.

## 1.2 Handling Precautions

---

- Although the protective structure is defined to include cables, the cable terminal is not structurally waterproof and is not subject to the protective structure. Therefore, avoid using the product in any manner that may cause water entry via the cable end.
- Due to the detection principle, if there is a background object in a particular zone, a distance different from the actual distance may be displayed. Confirm actual operations in an actual operating environment.

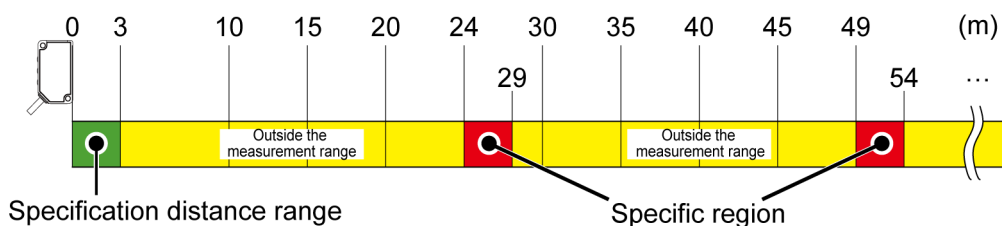

If an object exists in a particular zone, shield the laser within 24 m.

### Other matters

- When this product becomes unusable or unnecessary, dispose of the product properly as industrial waste in accordance with the applicable law in the country.
- When exporting the product or when taking it out of Japan, the user is required to check applicable standards, laws and regulations.
- If the user resells or transfers our company products to a third party, product specifications, installation manuals, user's manuals, and all other documents provided to the user from our company must be submitted to the third party.

## 1.3 Terminology

Term	Description
TOF	TOF stands for time of flight. The TOF sensor measures the distance to the object to be detected by emitting light and measuring the flight time of light until the light reflected on the sensing object returns to the sensor.
Measurement display	A display that allows the user to check the measured distance (measured value) between the sensor and the sensing object
Emitted beam spot check mode	In this mode, the sensor emits beams at a certain power level so that laser spot beams can be identified. The sensor flashes every second, enabling laser spot beams to be identified more brightly than under the normal measurement conditions.
Normal sensing mode	In this mode, control output ON/OFF is controlled for a single threshold.
Window comparator mode	In this mode, control output ON/OFF is controlled by setting two thresholds (threshold 1 and threshold 2).
Teaching	Refers to setting measured values to the threshold values by using an actual object to be detected.
Master workpiece	A sensing object that is used as the base to set thresholds.
Threshold	A value that is used to judge if a measure value falls within the predetermined range. If the value falls within the range, the output operation indicator will light up. (At light-ON)

## 1.4 Open Source Software (OSS)

---

### 1.4 Open Source Software (OSS)

This product includes the open source software listed below.

- AFBR-S50-API (BSD 3-Clause)
- stm32f4xx\_hal\_driver (BSD 3-Clause)
- CMSIS Device (BSD 3-Clause)
- CMSIS compiler ICCARM (Apache-2.0)
- CMSIS (Apache-2.0)
- DAC8760 (BSD 3-Clause)

Software listed above is distributed with the expectation of effectiveness as a single piece of software, but there is no guarantee provided, including implied guarantees regarding viability as a product and/or suitability for specific purposes. For details, refer to the following license conditions.

For at least three years from the sale of this product, Panasonic will provide the following to any person who has contacted the hotline below at actual cost: the license information, a complete machine-readable copy of the source code corresponding to the software, and the copyright information.

Panasonic Hotline on OSS: [oss-cd-request@gg.jp.panasonic.com](mailto:oss-cd-request@gg.jp.panasonic.com)

### 1.4.1 Copyright · License

AFBR-S50-API

Copyright (c) 2021, Broadcom Inc All rights reserved.

Redistribution and use in source and binary forms, with or without modification, are permitted provided that the following conditions are met:

1. Redistributions of source code must retain the above copyright notice, this list of conditions and the following disclaimer.
2. Redistributions in binary form must reproduce the above copyright notice, this list of conditions and the following disclaimer in the documentation and/or other materials provided with the distribution.
3. Neither the name of the copyright holder nor the names of its contributors may be used to endorse or promote products derived from this software without specific prior written permission.

THIS SOFTWARE IS PROVIDED BY THE COPYRIGHT HOLDERS AND CONTRIBUTORS "AS IS" AND ANY EXPRESS OR IMPLIED WARRANTIES, INCLUDING, BUT NOT LIMITED TO, THE IMPLIED WARRANTIES OF MERCHANTABILITY AND FITNESS FOR A PARTICULAR PURPOSE ARE DISCLAIMED. IN NO EVENT SHALL THE COPYRIGHT HOLDER OR CONTRIBUTORS BE LIABLE FOR ANY DIRECT, INDIRECT, INCIDENTAL, SPECIAL, EXEMPLARY, OR CONSEQUENTIAL DAMAGES (INCLUDING, BUT NOT LIMITED TO, PROCUREMENT OF SUBSTITUTE GOODS OR SERVICES; LOSS OF USE, DATA, OR PROFITS; OR BUSINESS INTERRUPTION) HOWEVER CAUSED AND ON ANY THEORY OF LIABILITY, WHETHER IN CONTRACT, STRICT LIABILITY, OR TORT (INCLUDING NEGLIGENCE OR OTHERWISE) ARISING IN ANY WAY OUT OF THE USE OF THIS SOFTWARE, EVEN IF ADVISED OF THE POSSIBILITY OF SUCH DAMAGE.

stm32f4xx\_hal\_driver

COPYRIGHT(c) 2017 STMicroelectronics All rights reserved.

Redistribution and use in source and binary forms, with or without modification, are permitted provided that the following conditions are met:

1. Redistributions of source code must retain the above copyright notice, this list of conditions and the following disclaimer.
2. Redistributions in binary form must reproduce the above copyright notice, this list of conditions and the following disclaimer in the documentation and/or other materials provided with the distribution.
3. Neither the name of STMicroelectronics nor the names of its contributors may be used to endorse or promote products derived from this software without specific prior written permission.

THIS SOFTWARE IS PROVIDED BY THE COPYRIGHT HOLDERS AND CONTRIBUTORS "AS IS" AND ANY EXPRESS OR IMPLIED WARRANTIES, INCLUDING, BUT NOT LIMITED TO, THE IMPLIED WARRANTIES OF MERCHANTABILITY AND FITNESS FOR A PARTICULAR PURPOSE ARE DISCLAIMED. IN NO EVENT SHALL THE COPYRIGHT HOLDER OR CONTRIBUTORS BE LIABLE FOR ANY DIRECT, INDIRECT, INCIDENTAL, SPECIAL, EXEMPLARY, OR CONSEQUENTIAL DAMAGES (INCLUDING, BUT NOT LIMITED TO, PROCUREMENT OF SUBSTITUTE GOODS OR SERVICES; LOSS OF USE, DATA, OR PROFITS; OR BUSINESS INTERRUPTION) HOWEVER CAUSED AND ON ANY THEORY OF LIABILITY, WHETHER IN CONTRACT, STRICT LIABILITY, OR TORT (INCLUDING NEGLIGENCE OR OTHERWISE) ARISING IN ANY WAY OUT OF THE USE OF THIS SOFTWARE, EVEN IF ADVISED OF THE POSSIBILITY OF SUCH DAMAGE.

## 1.4 Open Source Software (OSS)

---

CMSIS Device

COPYRIGHT(c) 2017 STMicroelectronics All rights reserved.

Redistribution and use in source and binary forms, with or without modification, are permitted provided that the following conditions are met:

1. Redistributions of source code must retain the above copyright notice, this list of conditions and the following disclaimer.
2. Redistributions in binary form must reproduce the above copyright notice, this list of conditions and the following disclaimer in the documentation and/or other materials provided with the distribution.
3. Neither the name of STMicroelectronics nor the names of its contributors may be used to endorse or promote products derived from this software without specific prior written permission.

THIS SOFTWARE IS PROVIDED BY THE COPYRIGHT HOLDERS AND CONTRIBUTORS "AS IS" AND ANY EXPRESS OR IMPLIED WARRANTIES, INCLUDING, BUT NOT LIMITED TO, THE IMPLIED WARRANTIES OF MERCHANTABILITY AND FITNESS FOR A PARTICULAR PURPOSE ARE DISCLAIMED. IN NO EVENT SHALL THE COPYRIGHT HOLDER OR CONTRIBUTORS BE LIABLE FOR ANY DIRECT, INDIRECT, INCIDENTAL, SPECIAL, EXEMPLARY, OR CONSEQUENTIAL DAMAGES (INCLUDING, BUT NOT LIMITED TO, PROCUREMENT OF SUBSTITUTE GOODS OR SERVICES; LOSS OF USE, DATA, OR PROFITS; OR BUSINESS INTERRUPTION) HOWEVER CAUSED AND ON ANY THEORY OF LIABILITY, WHETHER IN CONTRACT, STRICT LIABILITY, OR TORT (INCLUDING NEGLIGENCE OR OTHERWISE) ARISING IN ANY WAY OUT OF THE USE OF THIS SOFTWARE, EVEN IF ADVISED OF THE POSSIBILITY OF SUCH DAMAGE.

CMSIS compiler ICCARM

Copyright (c) 2017-2018 IAR Systems

Licensed under the Apache License, Version 2.0 (the "License")  
you may not use this file except in compliance with the License.

You may obtain a copy of the License at

<http://www.apache.org/licenses/LICENSE-2.0>

Unless required by applicable law or agreed to in writing, software distributed under the License is distributed on an "AS IS" BASIS, WITHOUT WARRANTIES OR CONDITIONS OF ANY KIND, either express or implied.

See the License for the specific language governing permissions and limitations under the License.

CMSIS

Copyright (c) 2009-2018 Arm Limited. All rights reserved.

SPDX-License-Identifier: Apache-2.0

Licensed under the Apache License, Version 2.0 (the License)  
you may not use this file except in compliance with the License.

You may obtain a copy of the License at

<http://www.apache.org/licenses/LICENSE-2.0>

Unless required by applicable law or agreed to in writing, software distributed under the License is distributed on an AS IS BASIS, WITHOUT WARRANTIES OR CONDITIONS OF ANY KIND, either express or implied.

See the License for the specific language governing permissions and limitations under the License.



DAC8760

Copyright (c) 2014 Texas Instruments Incorporated

Redistribution and use in source and binary forms, with or without modification, are permitted provided that the following conditions are met:

Redistributions of source code must retain the above copyright notice, this list of conditions and the following disclaimer.

Redistributions in binary form must reproduce the above copyright notice, this list of conditions and the following disclaimer in the documentation and/or other materials provided with the distribution.

Neither the name of Texas Instruments Incorporated nor the names of its contributors may be used to endorse or promote products derived from this software without specific prior written permission.

THIS SOFTWARE IS PROVIDED BY THE COPYRIGHT HOLDERS AND CONTRIBUTORS "AS IS" AND ANY EXPRESS OR IMPLIED WARRANTIES, INCLUDING, BUT NOT LIMITED TO, THE IMPLIED WARRANTIES OF MERCHANTABILITY AND FITNESS FOR A PARTICULAR PURPOSE ARE DISCLAIMED. IN NO EVENT SHALL THE COPYRIGHT HOLDER OR CONTRIBUTORS BE LIABLE FOR ANY DIRECT, INDIRECT, INCIDENTAL, SPECIAL, EXEMPLARY, OR CONSEQUENTIAL DAMAGES (INCLUDING, BUT NOT LIMITED TO, PROCUREMENT OF SUBSTITUTE GOODS OR SERVICES; LOSS OF USE, DATA, OR PROFITS; OR BUSINESS INTERRUPTION) HOWEVER CAUSED AND ON ANY THEORY OF LIABILITY, WHETHER IN CONTRACT, STRICT LIABILITY, OR TORT (INCLUDING NEGLIGENCE OR OTHERWISE) ARISING IN ANY WAY OUT OF THE USE OF THIS SOFTWARE, EVEN IF ADVISED OF THE POSSIBILITY OF SUCH DAMAGE.

## 1.5 Regulations and Standards

---

### 1.5 Regulations and Standards

#### ■ Conforming directives and conforming regulations

EU Regulations: EMC Directive 2014/30/EU

UK Regulations: EMC Regulations 2016/1091

#### ● Applicable standards

- EN 61000-6-4
- EN 61000-6-2

USA regulations: FDA21 CFR1040.10, and 1040.11 (Laser Notice No.56 applied)

#### ■ Conforming standards

#### ● USA/Canada Standards

- UL 61010-1
- CAN/CSA No.61010-1

#### ● Other standards

- IEC 60825-1
- JIS C 6802
- GB 7247.1
- KS C IEC 60825-1



- When using this product in a region other than those listed above, be sure to check and comply with the regulations and standards applicable in the country or region where the product is used.

**1.6 Laser Safety Standards**

**1.6.1 IEC / JIS / GB / KS**

To prevent laser products from affecting their users, IEC, JIS, GB, and KS standards have the following respective standards:

These standards classify laser products into classes according to the danger level of laser, and prescribe safety and preventive measures that should be implemented for each class.

This product belongs to Class 1 laser products according to IEC 60825-1 (JIS C 6802, GB 7247.1, KS C IEC 60825-1) "Safety of Laser Products".

**Explanation of danger level**

Classification	Overview of hazard evaluation
Class 1	A laser that is safe when operated under operating conditions that can be reasonably foreseen

(Note 1) When an unexpected failure occurs, dangerous radiation may be generated. Therefore, pay special attention to safety.

## 1.6 Laser Safety Standards

### ■ Warning label

The following label is affixed to the side of this product based on the safety standards for laser products.



<Labeling position>

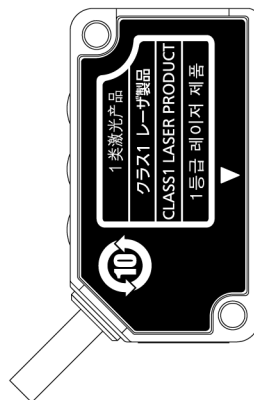
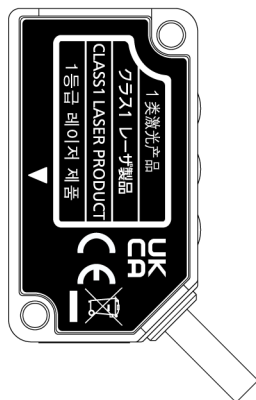

### 1.6.2 FDA

#### ■ Exporting to the US

If this product is incorporated into facilities or equipment to be exported to the US, it is subject to the laser regulations of the US Food and Drug Administration (FDA). To prevent laser products from affecting their users, PART1040 (Performance Standards for Light-Emitting Products) was established as one of the FDA regulations. These standards classify laser products into classes according to the hazard level of laser and prescribe safety and preventive measures that should be implemented for each class.

This product complies with the FDA regulations (FDA 21 CFR 1040.10 and 1040.11) in accordance with FDA Laser Notice No. 56, except for complying with IEC 60825-1 Ed. 3. (Class 1 laser product)

When exporting this product to the US, affix the FDA certificate / identification label near the end of the cable.

■ Certificate / identification label

Panasonic Industrial Devices  
SUNX Co.,Ltd.  
2431-1,Ushiyama-cho,Kasugai,  
Aichi,486-0901 Japan  
Complies with 21 CFR 1040.10 and  
1040.11 except for conformance with  
IEC 60825-1 Ed.3,as described in Laser  
Notice No.56 dated May,8,2019.  
MANUFACTURED:  
[Blank]

Brown : 24V DC,Class2  
Blue : 0V  
Black : OUT(30V 50mA)  
Pink : EXTERNAL INPUT  
Gray : ANALOG OUT(0-5V)  
(4-20mA)  
Shield : ANALOG GROUND

<Labeling position>

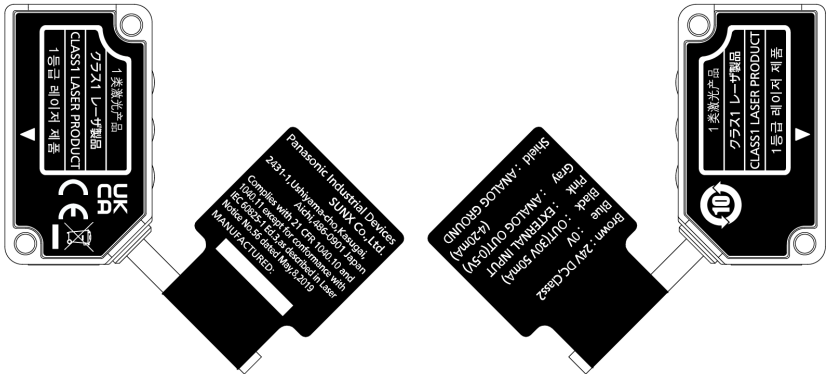

## 1.7 Contents of Package

---

### 1.7 Contents of Package

The following accessories are included in the product package. Before using the product, make sure that no items are missing.

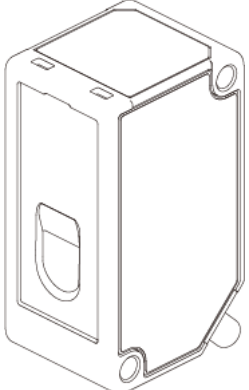
Sensor
<p><b>HG-F13A-A-N</b> / NPN type, <b>HG-F13A-A-P</b> / PNP type</p> <ul style="list-style-type: none"><li>• Sensor unit</li></ul>  <ul style="list-style-type: none"><li>• FDA certificate / identification label: 1 pc.</li><li>• Installation Instructions Manual (English / Japanese, Chinese / Korean): 1 volume each</li><li>• General Information for Safety, Compliance, and Instructions: 1 volume</li></ul>

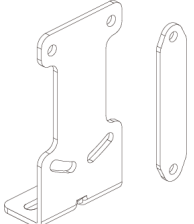
Mounting bracket (optional)
<p><b>MS-HG-01</b> / Simple mounting bracket</p> <ul style="list-style-type: none"><li>• Bracket: 1 set</li></ul>  <ul style="list-style-type: none"><li>• M3 screw with washer (length: 25 mm): 2 pcs.</li></ul>

# 2 System Configuration

---

2.1 Principle of Measurement .....	2-2
2.2 Description of Parts.....	2-3

## 2.1 Principle of Measurement

---

### 2.1 Principle of Measurement

The system is designed to measure the time required for a laser beam that is emitted from the sensor and reflected on the measurement object to return to the sensor. The measured time is converted into a distance. (TOF system)

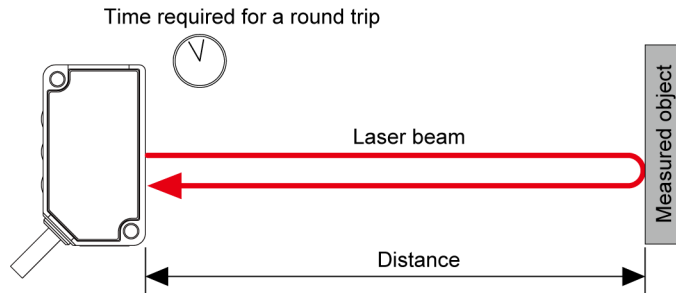



## 2.2 Description of Parts

### ■ Sensor unit

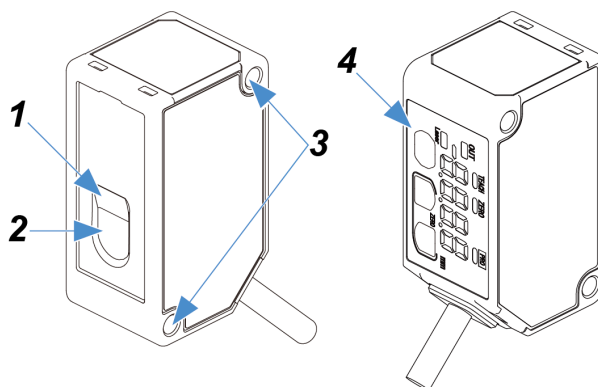

	Name	Function
1	Beam emitting part (laser opening)	This part emits laser beams.
2	Beam receiving part	This part receives the beam reflected on the measurement object.
3	Mounting hole	These hole are used to mount the sensor on machinery with M3 screws.
4	Operation/display section	This section is used to check measured values and indicators, as well as to specify and change settings for each function.

### ■ Operation/display section

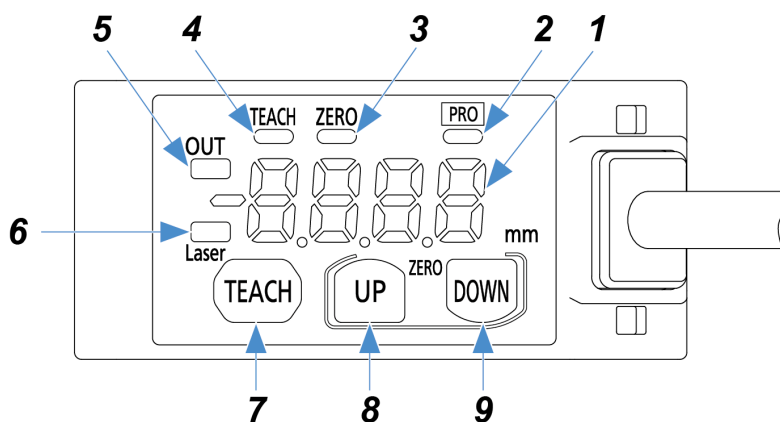

	Name	Function
1	Digital display (Red)	Displays measured values and settings.
2	PRO indicator (Yellow)	Lights up when PRO mode is set.
3	Zero set indicator (Yellow)	Lit while the zero set function is ON.
4	Teaching indicator (Yellow)	Lit while teaching is in progress.

## 2.2 Description of Parts

---

	<b>Name</b>	<b>Function</b>
<b>5</b>	Output operation indicator (Orange)	Lit while control output is ON.
<b>6</b>	Laser radiation indicator (Green)	Lit while laser beams are being emitted.
<b>7</b>	TEACH key	Use to change setting items and settings when configuring settings.
<b>8</b>	UP key	
<b>9</b>	DOWN key	

# 3 Installation and Connection

---

3.1 Installation Method.....	3-2
3.2 Wiring Connection Diagram.....	3-4
3.3 Adjusting the beam axis.....	3-5

## 3.1 Installation Method

### 3.1 Installation Method

#### 1 2 Procedure

1. When mounting this product, use M3 screws (prepare separately). Tighten the screws to a torque of 0.5 N·m or less.

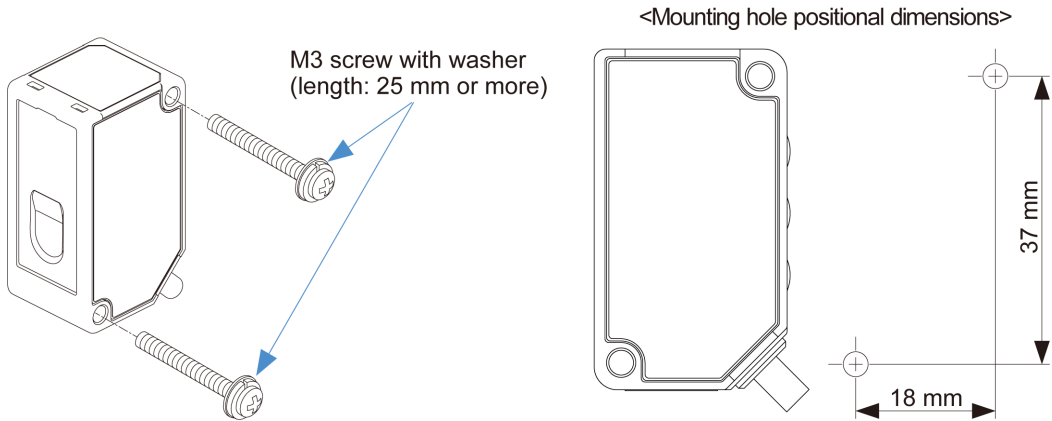

- When using multiple sensors, mount them so that emitted laser beams do not directly enter the beam receiving parts of other sensors in order to avoid mutual interference. Also, mount them so that spot beams irradiated on a workpiece do not overlap with those of other sensors.
- To prevent the product from falling due to loose screws, take prevention measures such as using screws with washers depending on the operating environment.



- Do not mount the sensors closely side by side to prevent heat generation. Otherwise, the product temperature may exceed the specified temperature due to heat generation.

Use the tightening torque of 0.5 N·m or less even when using the simple mounting bracket **MS-HG-01** (optional).

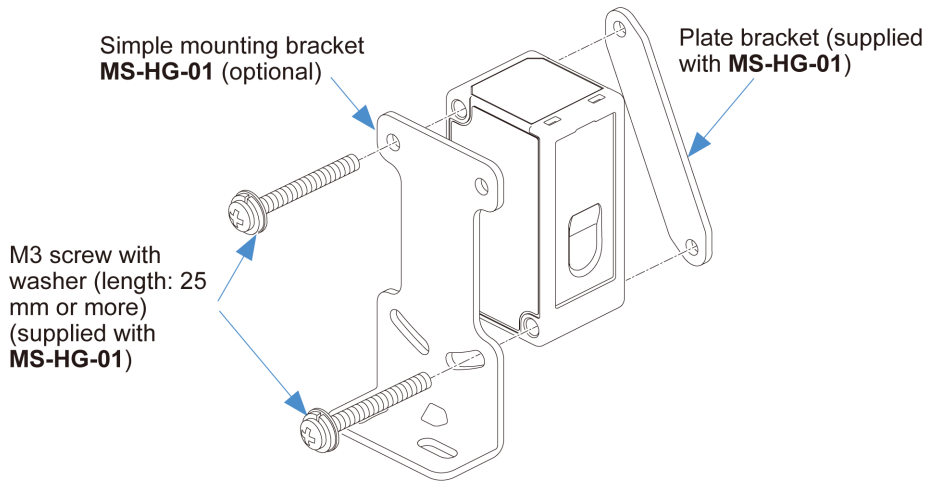

## 3.2 Wiring Connection Diagram

### 3.2 Wiring Connection Diagram

#### HG-F13A-A-N / NPN type

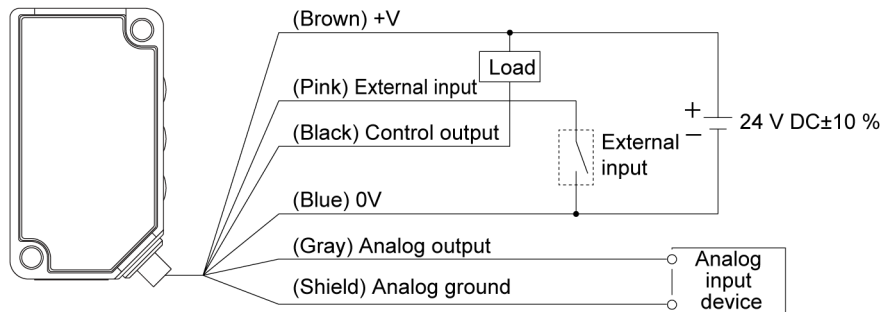

#### HG-F13A-A-P / PNP type

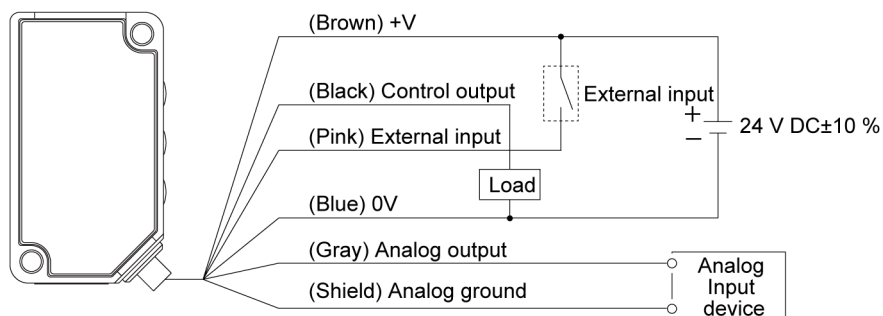

(Note 1) Insulate unused terminals to avoid error input or short circuit.

### 3.3 Adjusting the beam axis

After installing the sensor, turn ON the power supply and confirm that the spot beam hits the workpiece.

If the spot beam does not hit the workpiece, move the sensor while checking the spot beam to adjust the beam axis.

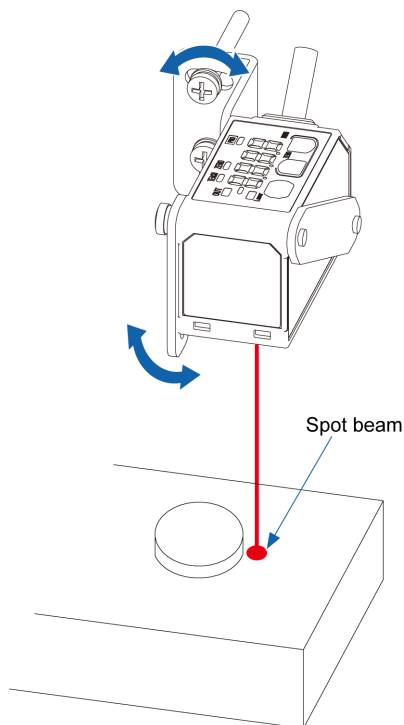

#### Note

- When adjusting the beam axis, set the **emitted beam spot check mode** in which the spot beam can be more easily observed.
- For the setting procedure of the **emitted beam spot check mode**, refer to "4.1.2 Emitted Beam Spot Check Mode".

(MEMO)



# 4 Basic Settings

---

4.1 Basic Setup Procedure .....	4-2
4.1.1 Flow of Operations up to Setup Completion .....	4-2
4.1.2 Emitted Beam Spot Check Mode .....	4-4
4.1.3 2-point Teaching (Normal Sensing Mode).....	4-5
4.2 Operation Check .....	4-7

## 4.1 Basic Setup Procedure

---

### 4.1 Basic Setup Procedure

This section explains how to set up the product in a factory default state, using basic workpiece detection in the background as an application example.

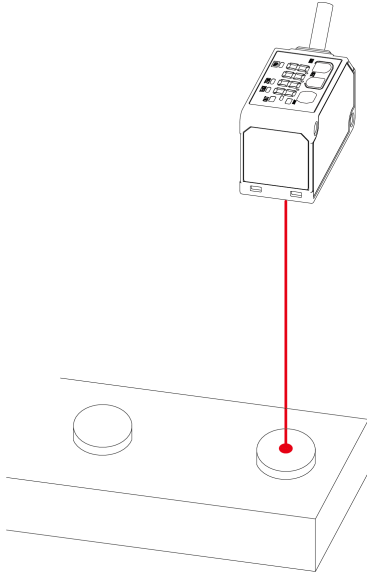

#### 4.1.1 Flow of Operations up to Setup Completion

Described below is the flow of operations up to measurement startup.

##### 1. Before power ON

Check package contents and confirm that all parts are complete.



##### 2. Installation

Install the sensor and connect the cables according to the installation and wiring methods.

["3.1 Installation Method"](#)

["3.2 Wiring Connection Diagram"](#)



##### 3. Power ON

Turn ON the power supply and confirm that the digital display of the sensor is displayed and laser beams are output from the sensor.



##### 4. Laser spot check

Check whether the laser spot beam of the sensor is irradiated on the workpiece at the location to be measured.

"3.3 Adjusting the beam axis"



### 5. Beam axis adjustment (if the spot beam does not hit the workpiece)

1. Adjust the beam axis so that the laser spot beam hits the location to be measured on the workpiece.
2. If necessary, set to the emitted beam spot check mode so that laser spot beam can be more easily observed.

"3.3 Adjusting the beam axis"

"4.1.2 Emitted Beam Spot Check Mode"



### 6. Setting up the functions

Perform the necessary function settings according to application.

"5.1 List of Setting Items"



### 7. Threshold judgment

Perform teaching using the master workpiece.

It is also possible to set threshold values.

"5.9 Sensing Output Setting (Teaching)"



### 8. Start measurement

Measurement is started. Check the measured values and indicators on the digital display.

"4.2 Operation Check"

"2.2 Description of Parts"



### 9. Fine adjustment

Perform fine adjustment on threshold values as necessary.

"5.2 Threshold Fine Adjustment"

## 4.1 Basic Setup Procedure

### 4.1.2 Emitted Beam Spot Check Mode

To make it easy to check if the laser spot beam is hitting the workpiece, you can make settings so that the spot beam becomes brighter and flashed.

Use the following procedure to set the emitted beam spot check mode and perform adjustment.

#### 1 2 Procedure

1. After turning the power ON, make sure that the following measurement display appears and then hold down the UP key for 3 seconds or longer. The display changes to the emitted beam spot check mode.

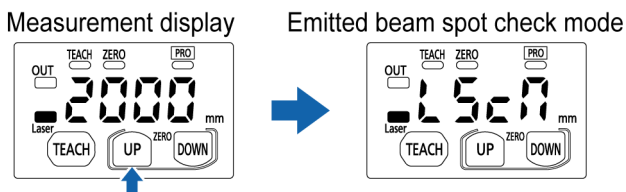

Hold down for 3 seconds.

2. A spot beam is emitted from the sensor every second. Check the spot beam and adjust the beam axis.

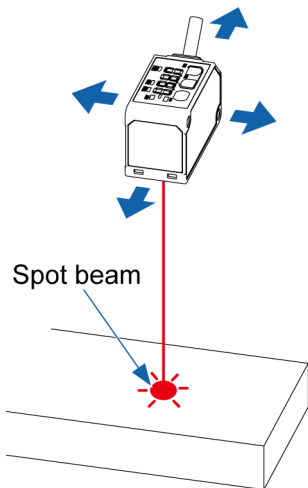

- When the emitted beam spot check mode is used, sensing objects cannot be measured.
- By holding down the UP key for 3 seconds or longer while the emitted beam spot check mode is selected, you can return to the measurement display.
- The display automatically returns to the measurement display when 2 minutes elapse after the sensor is set to the emitted beam spot check mode. To continue to adjust the beam axis, hold down the UP key for 3 seconds or longer again to set the emitted beam spot check mode.

### 4.1.3 2-point Teaching (Normal Sensing Mode)

After installing the sensor, set the threshold using a sensing object.  
Use the following procedure to perform 2-point teaching.

#### 1 2 Procedure

1. Press the TEACH key when there is a background object.

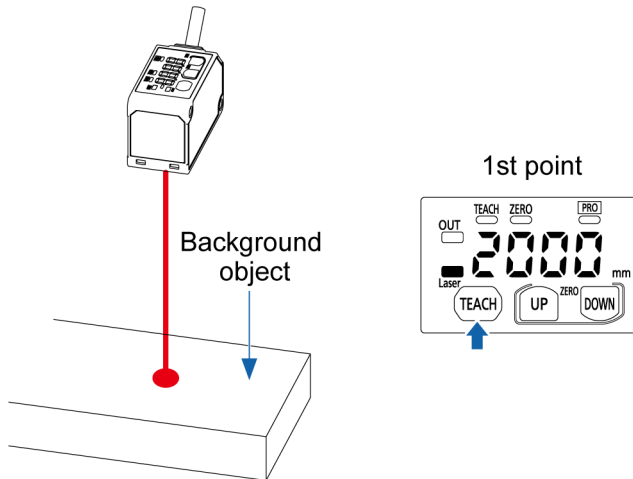

2. The teaching indicator is lit and "tch.2" is displayed on the digital display every 1.5 seconds.

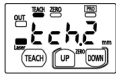

3. Insert a sensing object and press the TEACH key again. The intermediate value between the values measured by the 1st teaching and 2nd teaching will be set as a threshold and teaching will be completed.

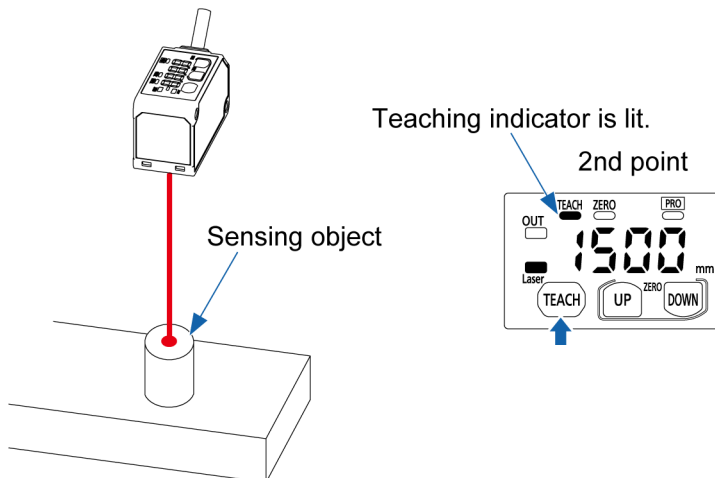

## 4.1 Basic Setup Procedure

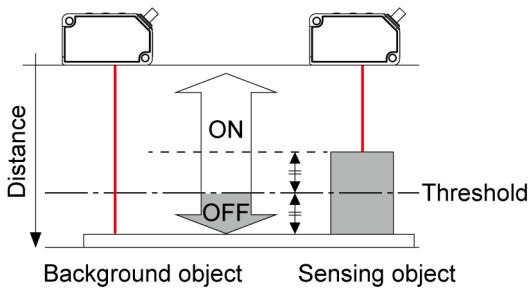

4. If the difference between the teaching results for the background object and the sensing object is equal to or larger than the shift amount, "good" will be displayed on the digital display. Then the desired threshold value is displayed and the teaching indicator turns OFF.

When stable sensing can be performed

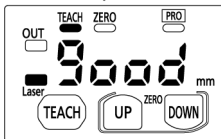

If the difference between the teaching results is less than the shift amount or if stable sensing cannot be performed, "Hard" will be displayed. Re-examine the positional relationship between the background object and the measured object and perform teaching again.

When stable sensing cannot be performed

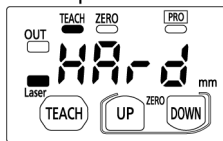

- Even when the difference between the teaching results is less than the shift amount or if the stable sensing cannot be performed, the intermediate value between the two sensing results is set as the threshold value.

## 4.2 Operation Check

Actually detect an object with the sensor set up in "4.1 Basic Setup Procedure".

### Note

- The following procedure is for when the output operation is set to light-ON (L-on). For the setting procedure of the output operation, refer to "5.8 Output Operation Setting".

## 1 2 Procedure

1. Check that the output operation indicator on the digital display is unlit.

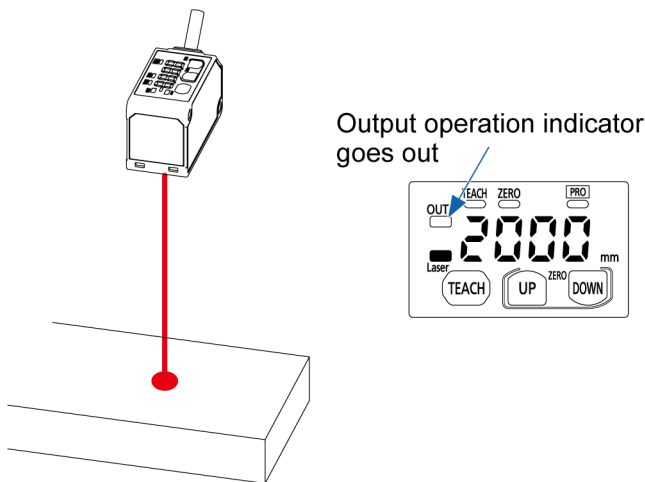

2. Insert a sensing object. Check that the measured value on the digital display fluctuates.

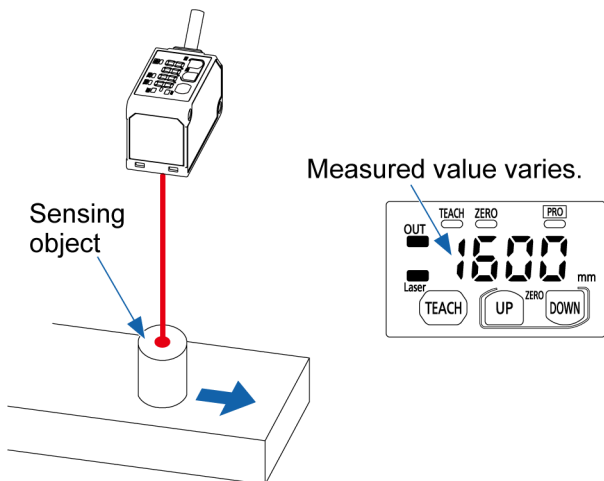

3. If the measured value falls within the range of the threshold set in "4.1.3 2-point Teaching (Normal Sensing Mode)", the output operation indicator will light up.

## 4.2 Operation Check

---

Output operation indicator  
is lit.

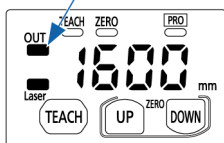



# 5 Setting Items and Setting Methods

---

5.1 List of Setting Items .....	5-2
5.2 Threshold Fine Adjustment .....	5-6
5.3 Threshold Selectable .....	5-7
5.4 Peak / Bottom Hold Function .....	5-9
5.5 Zero Set Function .....	5-10
5.5.1 Zero Set Setting .....	5-10
5.5.2 Zero Set Clearing .....	5-11
5.6 Key Lock Function .....	5-13
5.6.1 Key Lock Setting .....	5-13
5.6.2 Key Lock Release .....	5-13
5.7 Response Time Setting .....	5-15
5.8 Output Operation Setting .....	5-16
5.9 Sensing Output Setting (Teaching) .....	5-17
5.9.1 Normal Sensing Mode .....	5-18
5.9.2 Window Comparator Mode .....	5-21
5.10 Analog Output Setting .....	5-27
5.11 Analog Scaling Setting .....	5-28
5.12 Hysteresis Setting .....	5-32
5.13 Shift Amount Setting .....	5-33
5.14 External Input Setting .....	5-34
5.14.1 Zero Setting .....	5-34
5.14.2 Teaching .....	5-35
5.14.3 Emission Stop .....	5-35
5.15 Timer Setting .....	5-37
5.16 Timer Time Setting .....	5-40
5.17 Hold Setting .....	5-41
5.18 ECO Setting .....	5-43
5.19 Reset Setting .....	5-44

## 5.1 List of Setting Items

### 5.1 List of Setting Items

The items that can be set on the measurement display are as follows.

#### ■ Emitted beam spot check mode

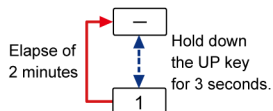

No.	Setting item	Display screen	Function	Reference page
-	Measurement display		-	-
1	Emitted beam spot check mode		To make it easy to check if the laser spot beam is hitting the workpiece, you can make settings so that the spot beam becomes brighter and flashed.	"P.4-4"

#### ■ Threshold fine adjustment

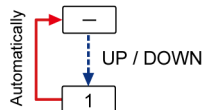

No.	Setting item	Display screen	Function	Reference page
-	Measurement display		-	-
1	Threshold fine adjustment		Used to make fine adjustment of the threshold.	"P.5-6"

#### ■ Threshold selectable

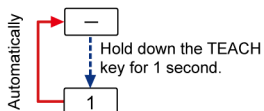

No.	Setting item	Display screen	Function	Reference page
-	Measurement display		-	-
1	Threshold selectable	 	Used to select either threshold 1 or threshold 2 for adjustment. (When set to the window comparator mode) <<Threshold 1 default: 1,000>> <<Threshold 2 default: 2,000>>	"P.5-7"

## ■ Peak / bottom hold function

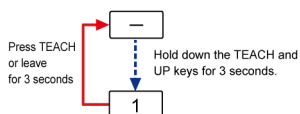

No.	Setting item	Display screen	Function	Reference page
-	Measurement display		-	-
1	Peak / bottom hold function	  	Used to hold the maximum value (peak value) or the minimum value (bottom value) of the measured values and display it on the display. <<Default: P.oFF>>	"P.5-9"

## ■ Zero set function

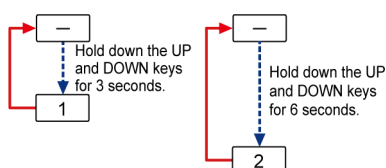

No.	Setting item	Display screen	Function	Reference page
-	Measurement display		-	-
1	Zero set setting		Used to forcibly set the measured value to "zero".	"P.5-10"
2	Zero set clearing		Used to clear the zero setting. <<Default: 0.oFF>>	"P.5-11"

## ■ Key lock function

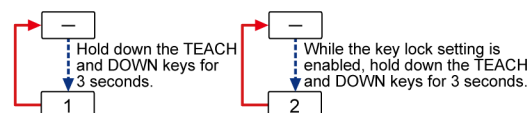







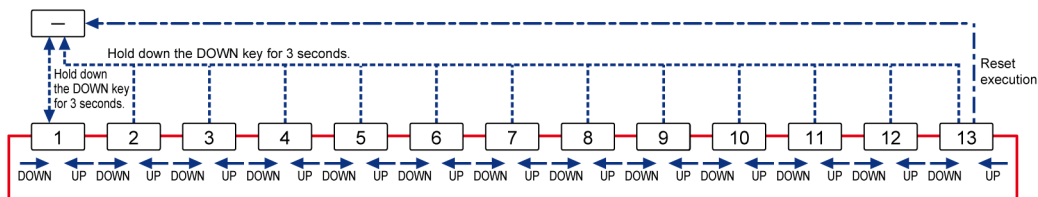

No.	Setting item	Display screen	Function	Reference page
-	Measurement display		-	-
1	Key lock setting		Used to disables key operation.	"P.5-13"

## 5.1 List of Setting Items

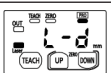
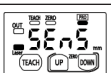
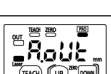

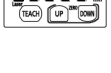

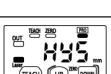
No.	Setting item	Display screen	Function	Reference page
2	Key lock release		Used to release the key lock setting. <<Default: Lc.oF>>	"P.5-13"

### ■ PRO mode



No.	Setting item	Display screen	Function	Reference page
-	Measurement display		-	-
1	Response time setting		Used to set the time from when the sensor starts measurement until a measurement value is finalized and output. <<Default: 100>>	"P.5-15"
2	Output operation setting		Used to set the operation mode of control output. <<Default: L-on>>	"P.5-16"
3	Sensing output setting (teaching)		Used to set the threshold teaching method. <<Default:..r">>	"P.5-17"
4	Analog output setting		Used to select analog output as either analog voltage output or analog current output. <<Default: Analog v.oUt>>	"P.5-27"
5	Analog scaling setting		Used to set optional two points as the upper limit value and the lower limit value for performing twopoint correction on the analog output before data is output. Set the measured value A as the lower limit value and the measured value B as the upper limit value. <<Measured value A default: 0, measured value B default: 3,000>>	"P.5-28"
6	Hysteresis setting		Used to set the hysteresis value. <<Default: 30>>	"P.5-32"
7	Shift amount setting		Used to set the threshold value for limit teaching and 1-point teaching. <<Default: 60>>	"P.5-33"
8	External input setting		Used to set either the zero setting, teaching, or emission halt function. <<Default: 0SEt>>	"P.5-34"
9	Timer setting		Used to set whether to use the timer setting of control output. <<Default: non>>	"P.5-37"

## 5.1 List of Setting Items

No.	Setting item	Display screen	Function	Reference page
10	Timer time setting		Used to set the timer time when "OFF delay timer, ON delay timer, or One-shot timer" is set in the timer setting. <<Default: 5>>	"P.5-40"
11	Hold setting		Used to set the digital display, the control output and analog output operation when a measurement error occurs (insufficient light intensity, saturation of light intensity, out of measurement range). <<Default: oFF>>	"P.5-41"
12	ECO setting		Used to turn OFF the digital display to save electricity when not operating. <<Default: oFF>>	"P.5-43"
13	Reset setting		Used to reset all the settings of this product to the factory default settings. <<Default: no>>	"P.5-44"

## 5.2 Threshold Fine Adjustment

### 5.2 Threshold Fine Adjustment

#### Overview

This function allows you to adjust the threshold value (unit: mm) to any desired value on the measurement display.

#### 1 2 Procedure

1. Press the UP key or DOWN key in the normal measurement mode, and the preset threshold value will be displayed.



2. Press the UP key or DOWN key and adjust the threshold value. After adjusting the threshold value to a desired value, press the TEACH key to set the new threshold value.

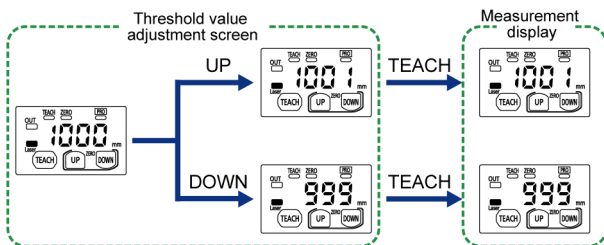

- If you do not make key operation for 3 seconds after changing the threshold value, the changed value is set as a new threshold value and the screen returns to the measurement display.
- Holding down the UP key or DOWN key will make the threshold value change faster.

Setting item	Set value	Default value
Threshold fine adjustment (When the zero set is cleared)	250 to 3,000 <sup>(Note 1)</sup>	1,000
Threshold fine adjustment (When the zero set is set)	-2,750 to 2,750 <sup>(Note 2)</sup>	

(Note 1) The settable maximum and minimum values of the threshold are affected by the hysteresis setting.

(Note 2) The settable maximum and minimum values of the threshold are affected by the zero set distance and the hysteresis setting.

## 5.3 Threshold Selectable

### ■ Overview

When using the window comparator mode, set both the threshold value 1 and threshold value 2. After setting, you can switch over the threshold value or adjust each threshold value.

For the procedure to set the window comparator mode, refer to "5.9.2 Window Comparator Mode".

### 1 2 Procedure

1. After moving to the threshold adjustment screen, hold down the TEACH key for 1 second or longer to alternately switch the threshold value to be displayed and operated between "Threshold value 1 (1\_SL)" and "Threshold value 2 (2\_SL)".

After the threshold value is set, "1\_SL" or "2\_SL" is displayed for one second and then the screen will automatically return to the measurement display.

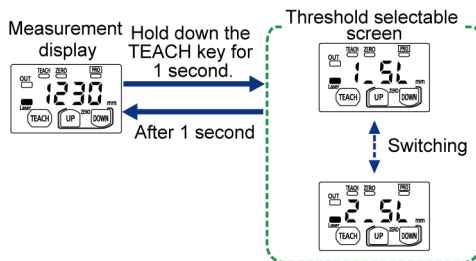

2. When adjusting the threshold value just switched over, press the UP key or DOWN key on the measurement display and adjust the threshold value.

After adjusting the threshold value to a desired value, press the TEACH key to set the new threshold value.

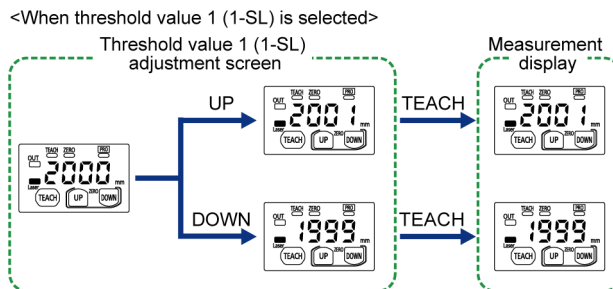

- The value for the threshold value 2 cannot be smaller than that for the threshold value 1.

### Note

- If you do not make key operation for 3 seconds after changing the threshold value, the changed value is set as a new threshold value and the screen returns to the measurement display.
- Holding down the UP key or DOWN key will make the threshold value change faster.

## 5.3 Threshold Selectable

---

Setting item	Set value	Setting range	Default value
Threshold selectable (When the zero set is cleared)	Threshold value 1 (1_SL)	250 to 3,000 <sup>(Note 1)</sup>	1,000
	Threshold value 2 (2_SL)		2,000
Threshold selectable (When the zero set is set)	Threshold value 1 (1_SL)	-2,750 to 2,750 <sup>(Note 2)</sup>	1,000
	Threshold value 2 (2_SL)		2,000

(Note 1) The settable maximum and minimum values of the threshold are affected by the hysteresis setting.

(Note 2) The settable maximum and minimum values of the threshold are affected by the zero set distance and the hysteresis setting.



## 5.4 Peak / Bottom Hold Function

### ■ Overview

This function is used to hold the maximum value (peak value) or the minimum value (bottom value) of the measured values and display it on the display.

The maximum value and minimum value are constantly updated during measurement.

### 1 2 Procedure

1. Hold down the TEACH key and UP key on the measurement display for 3 seconds, and "P.oFF" will be displayed on the digital display.

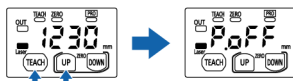

Hold down for 3 seconds.

2. Press the UP or DOWN key to select a function desired to be set and then press the TEACH key to finalize the setting.

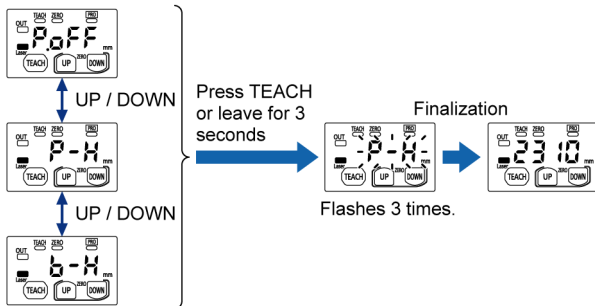

Name	Digital display	Function
Hold function release	P.oFF	Used to release the hold state and output the current measured value.
Peak hold	P-H	Used to output the maximum value of the measured value.
Bottom hold	b-H	Used to output the minimum value of the measured value.



- If you do not make key operation for 3 seconds after selecting a function, the changed function is set as a new function and the screen returns to the measurement display.
- When the zero set function is executed, the held value is reset.

Setting item	Set value	Default value
Peak / bottom hold function	Hold function disabled (P.oFF) Peak hold (P-H) Bottom hold (b-H)	P.oFF

## 5.5 Zero Set Function

### 5.5 Zero Set Function

#### ■ Overview

This function is used to forcibly set the measured value to "zero".

You can use this function to adjust to the reference zero point when the sensor has been replaced or when the workpiece has been changed.

When the zero set is set, the measured value at the location where the setting is executed is set to zero.

Depending on where the zero set is set, the display value for the sensing location changes.

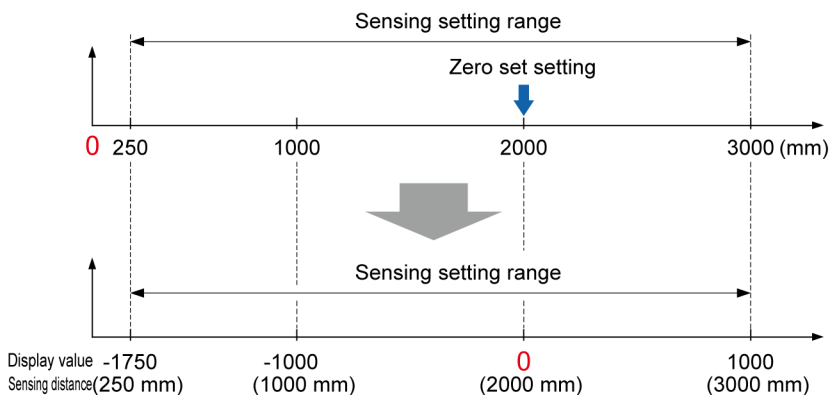

#### 5.5.1 Zero Set Setting

### 1 2 Procedure

1. Simultaneously hold down the UP key and DOWN key for 3 seconds. "0" is displayed on the digital display and, when the keys are released, "0" flashes three times to indicate that the setting has been completed. When the zero set setting is enabled, the zero set indicator lights up.

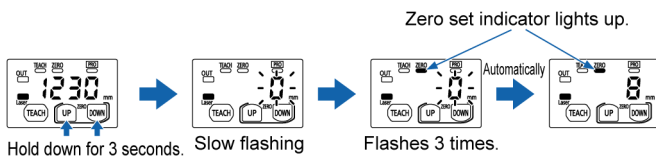

- Depending on where the zero set is set, the threshold value also changes. Therefore, the threshold value may exceed the sensing distance range (250 mm to 3,000 mm). If the threshold value is set outside the range, correct measurement cannot be obtained.

Re-examine the measurement conditions including resetting the threshold value as necessary.

For the resetting procedure of the threshold value, refer to "5.2 Threshold Fine Adjustment".

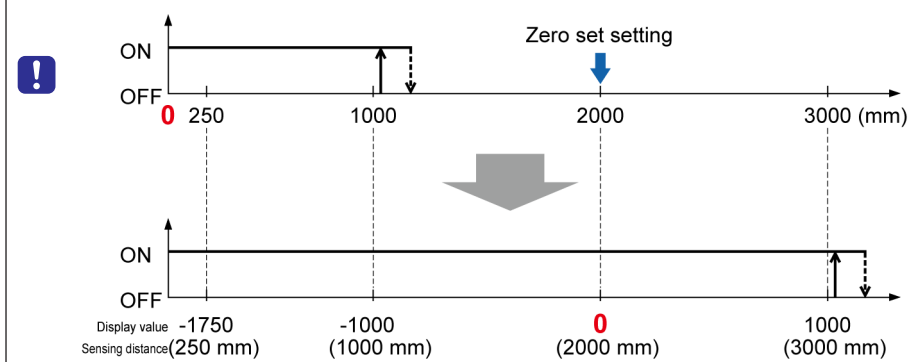

### Note

- When the zero set function is executed while the peak / bottom hold function is enabled, the held measured value is reset, making it impossible to set the zero set function.
- When an error occurs, the zero set setting cannot be made.
- The zero set function can also be set using an external input. For detailed setting procedure, refer to "5.14 External Input Setting".

## 5.5.2 Zero Set Clearing

### 1 2 Procedure

- While the zero set setting is enabled, simultaneously hold down the UP key and DOWN key for 6 seconds.

"0.oFF" is displayed on the digital display and the zero set is cleared.

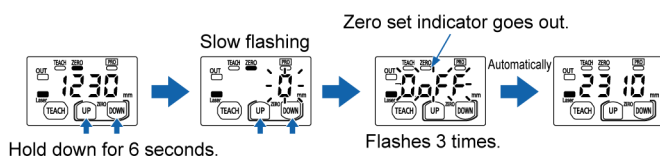

### Note

- While the zero set setting is enabled, enable the peak / bottom hold function, and the zero set setting is cleared.

## 5.5 Zero Set Function

---

Setting item	Set value	Default value
Zero setting	Zero set setting (0) Zero set clearing (0.oFF)	0.oFF

## 5.6 Key Lock Function

### ■ Overview

This function is used to disable key operation to prevent the conditions set in each setting mode from being changed by mistake.

While the key lock setting is activated, all key operations other than key lock release cannot be performed.

### 5.6.1 Key Lock Setting

#### 1 2 Procedure

1. Simultaneously hold down the TEACH key and DOWN key for 3 seconds.  
"Lc.on" is displayed on the digital display and, when the keys are released, "Lc.on" flashes three times to indicate that the setting has been completed.

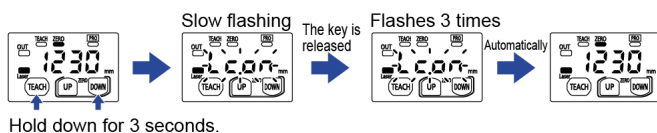

#### Note

- Press the UP key or DOWN key while the key lock setting is enabled, and the current threshold value will be displayed.
- If you press the TEACH key while the key lock setting is enabled, "Loc" will be displayed on the digital display.



However, in the window comparator mode, you can switch the threshold value by holding down the TEACH key.

### 5.6.2 Key Lock Release

#### 1 2 Procedure

1. While the key lock setting is enabled, simultaneously hold down the TEACH key and DOWN key for 3 seconds.  
"Lc.oF" is displayed on the digital display and the key lock is released.

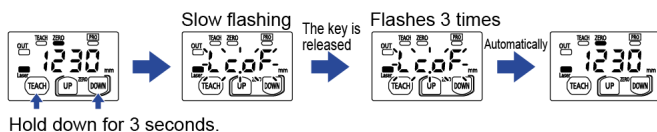

## 5.6 Key Lock Function

---

Setting item	Set value	Default value
Key lock	Key lock setting (Lc.on) Key lock release (Lc.oF)	Lc.oF

## 5.7 Response Time Setting

### ■ Overview

This setting is used to set the time (response time) (unit: ms) from when the sensor starts measurement until a judgment value is finalized and output.

### ■ Setting method

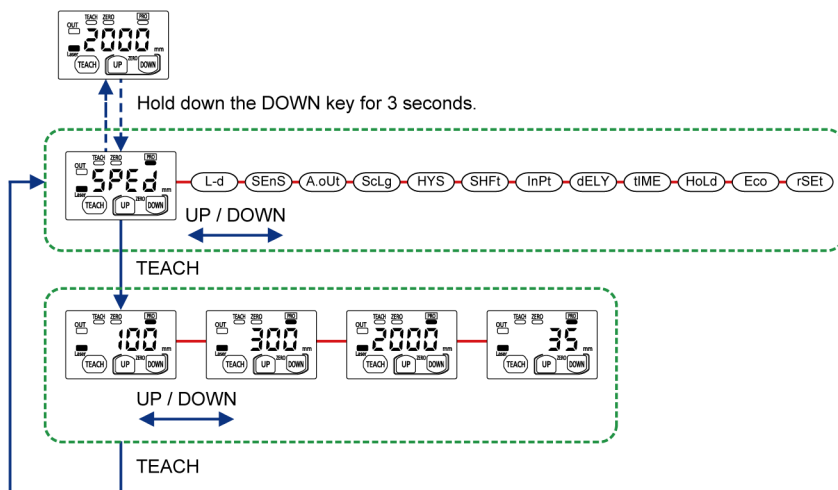

### 📄 Note

- Setting the response time to a small value (fast) enables the sensor to respond to momentary changes.  
Setting the response time to a large value (slow) enables the sensor to be less influenced by sudden changes or similar events.
- Hold down the DOWN key for 3 seconds or longer on the setting screen, and the setting change is suspended and the screen returns to the measurement display.

Setting item	Set value	Default value
Response time setting	35	100
	100	
	300	
	2,000	

## 5.8 Output Operation Setting

### 5.8 Output Operation Setting

#### ■ Overview

This setting is used to set the operation mode of control output.

When the operation mode is set to light-ON or dark-ON, control output operation will be as follows for each detection state.

Detection state	Output operation setting	
	Light-ON	Dark-ON
Light entry state	Control output ON	Control output OFF
Light interrupted state	Control output OFF	Control output ON

#### ■ Setting method

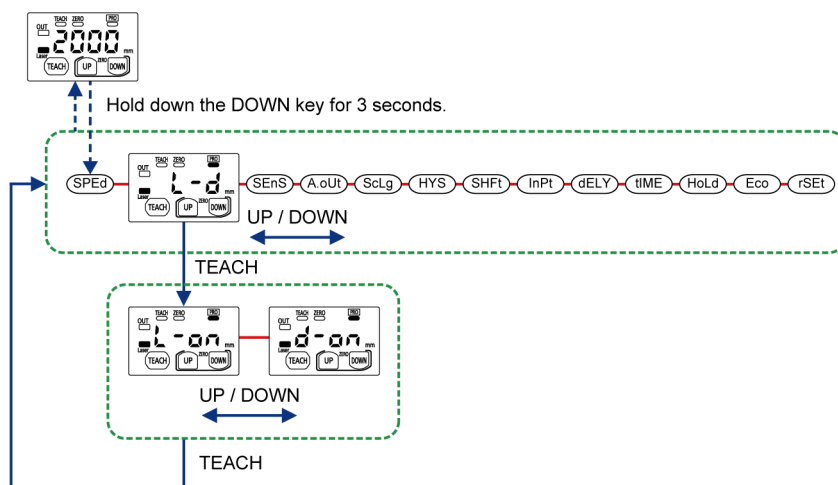

#### 📌 Note

- Hold down the DOWN key for 3 seconds or longer on the setting screen, and the setting change is suspended and the screen returns to the measurement display.
- The output operation indicator lights up when the control output is ON and goes out when the control output is OFF.

Setting item	Set value	Default value
Output operation setting	Light-ON (L-on) Dark-ON (d-on)	L-on



## 5.9 Sensing Output Setting (Teaching)

### ■ Overview

This setting is used to set the threshold teaching method.

Select the output mode of the control output from the normal sensing mode or window comparator mode (1-point teaching, 2-point teaching, and 3-point teaching).

The following section describes each teaching method.

### ■ Setting method

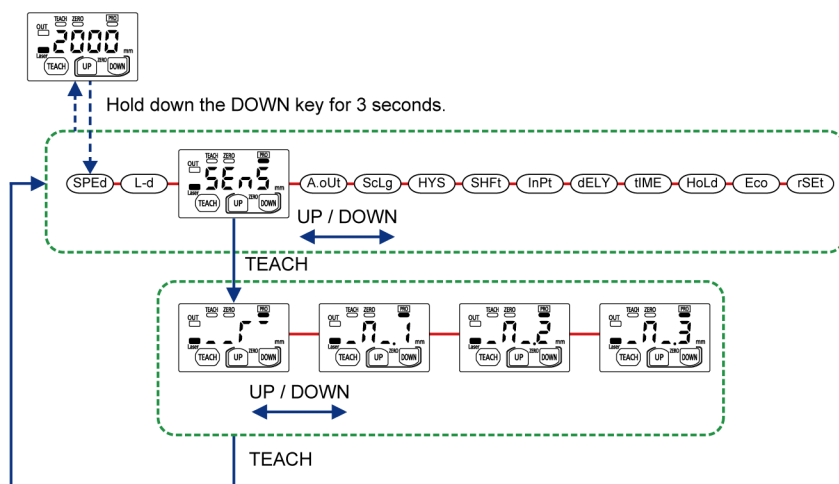

### 📌 Note

- Hold down the DOWN key for 3 seconds or longer on the setting screen, and the setting change is suspended and the screen returns to the measurement display.

Setting item	Sensing output setting	Teaching method		Default value
Sensing output setting	Normal sensing mode	2-point teaching		--.5-
		Limit teaching	--.5-	
	Window comparator mode	1-point teaching	.n.1	
		2-point teaching	.n.2	
	3-point teaching	.n.3		

## 5.9 Sensing Output Setting (Teaching)

---

### 5.9.1 Normal Sensing Mode

#### ■ Overview

In this mode, control output ON/OFF is controlled for a single threshold.

You can select the teaching method from either one of the following two types.

Set value	Operation	Reference page
2-point teaching	This method is to perform teaching on the reference plane of two sensing objects and to set the intermediate value of the teaching results as the threshold value.	"2-point Teaching"
Limit teaching	This method is to perform teaching on the reference plane of sensing objects and to set the value obtained from adding the shift value to or subtracting it from the teaching result as the threshold value.	"Limit Teaching"

### 2-point Teaching

---

#### ■ Overview

This method is to perform teaching on the reference plane of two sensing objects and to set the intermediate value of the teaching results as the threshold value.

For setting procedure, refer to "[4.1.3 2-point Teaching \(Normal Sensing Mode\)](#)".

### Limit Teaching

---

#### ■ Overview

This method is to perform teaching on the reference plane of sensing objects and to set the value obtained from adding the shift value to or subtracting it from the teaching result as the threshold value. This is a convenient teaching method for minute objects or when there is a background object.

#### **1** Procedure

1. Press the TEACH key when there is a background object or when there is a sensing object.

## 5.9 Sensing Output Setting (Teaching)

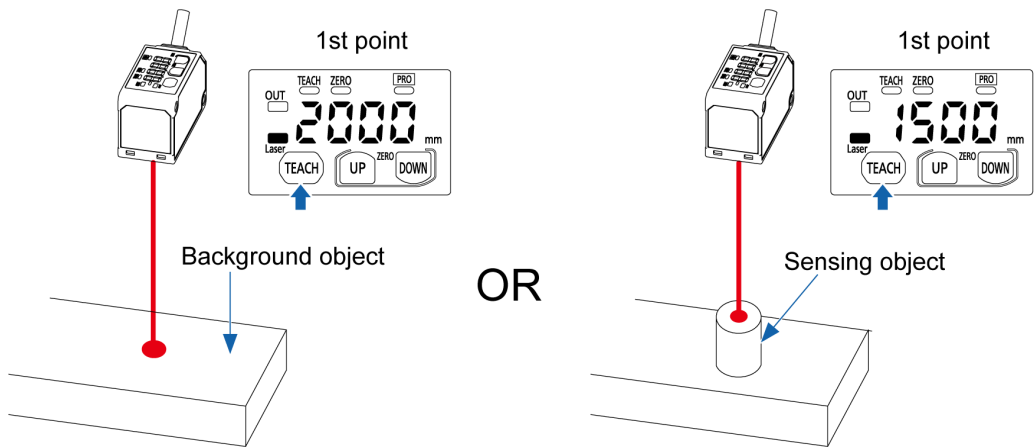

- The teaching indicator is lit and "tch.2" is displayed on the digital display every 1.5 seconds.

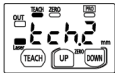

- Press the DOWN key when treating the background object as the standard.

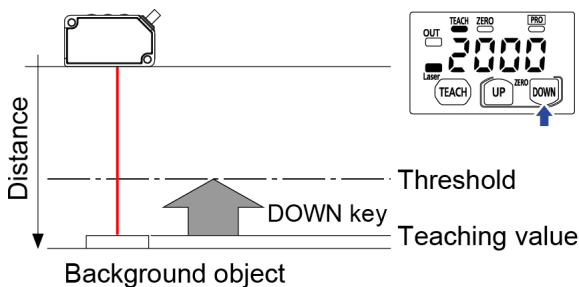

Press the UP key when treating the master workpiece as the standard.

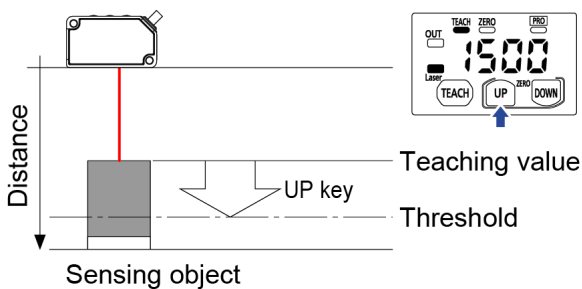

- If the difference between the teaching results for the background object and the sensing object is equal to or larger than the shift amount, "good" will be displayed on the digital display. Then the desired threshold value is displayed and the teaching indicator turns OFF.

When stable sensing  
can be performed

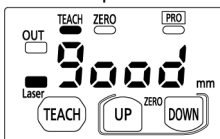

## 5.9 Sensing Output Setting (Teaching)

---

If the difference between the teaching results is less than the shift amount or if stable sensing cannot be performed, "Hard" will be displayed. Re-examine the positional relationship between the background object and the measured object and perform teaching again.

When stable sensing cannot be performed

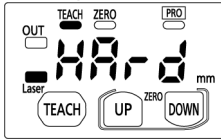

- Even when the difference between the teaching results is less than the shift amount or if the stable sensing cannot be performed, the intermediate value between the two sensing results is set as the threshold value.

## 5.9.2 Window Comparator Mode

### ■ Overview

In this mode, control output ON/OFF is controlled by setting two thresholds (threshold 1 and threshold 2).

You can select the teaching method from one of the following three types.

Set value	Operation	Reference page
1-point teaching	This method is to perform 1-point teaching on the distance from the reference plane of a sensing object and to set the threshold value 1 and threshold value 2.	"P.5-21"
2-point teaching	This method is to perform teaching for the reference plane of the sensing object 1 and sensing object 2 respectively and to set the threshold value 1 and threshold value 2.	"P.5-23"
3-point teaching	This method is to perform teaching for the reference plane of the sensing objects 1, 2, and 3 and to set the threshold value 1 and threshold value 2.	"P.5-24"

## 1-point Teaching

### ■ Overview

This method is to perform 1-point teaching on the distance from the reference plane of a sensing object and to set the value obtained by subtracting the shift amount from the teaching result as the threshold value 1, and the value obtained by adding the shift amount to the teaching result as the threshold value 2.

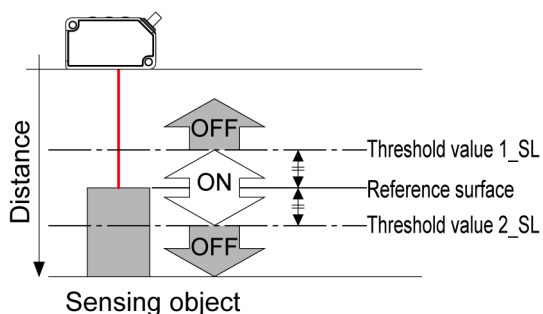

## 1 2 Procedure

1. With the sensing object inserted, press the TEACH key.  
The mode will be set to the teaching mode and the teaching indicator will be lit.

## 5.9 Sensing Output Setting (Teaching)

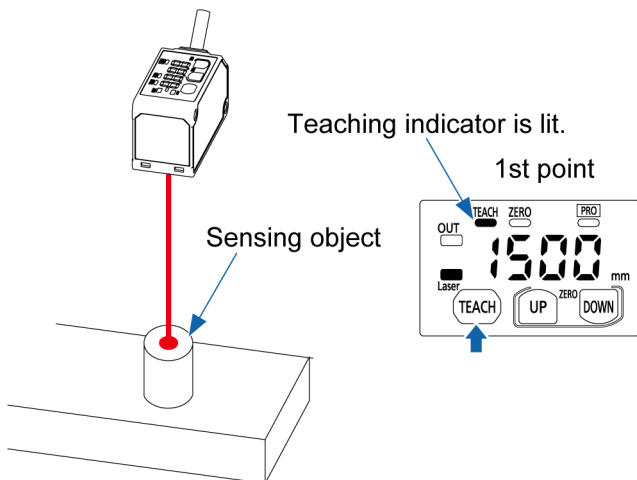

- "tch.1" will be displayed on the digital display every 1.5 seconds.



- Press the TEACH key.  
Teaching will be executed.

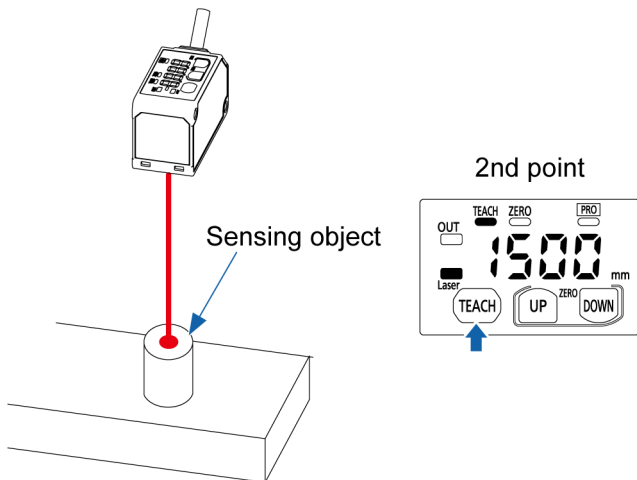

- The threshold value 1 and threshold value 2 will be set and teaching will be completed.
- The threshold value 1 and threshold value 2 will be set and teaching will be completed. If the difference between the teaching results for the background object and the sensing object is equal to or larger than the shift amount, "good" will be displayed on the digital display. Then the desired threshold value is displayed and the teaching indicator turns OFF.

When stable sensing  
can be performed

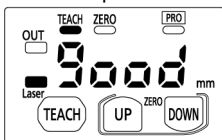

If the difference between the teaching results is less than the shift amount or if stable sensing cannot be performed, "Hard" will be displayed. Re-examine the positional relationship between the background object and the measured object and perform teaching again.

When stable sensing cannot be performed

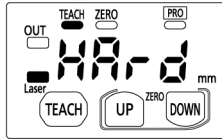

### 2-point Teaching

#### ■ Overview

This method is to perform teaching for the reference plane of the sensing object 1 and sensing object 2 respectively and to set the threshold value 1 and threshold value 2.

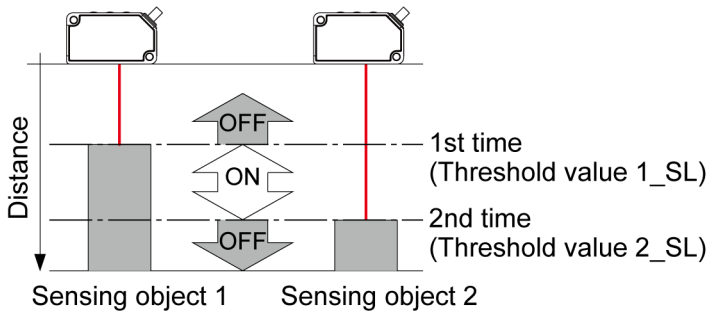

#### 1 2 Procedure

1. With the sensing object 1 inserted, press the TEACH key.  
Teaching for the first point will be executed and the teaching indicator will be lit.

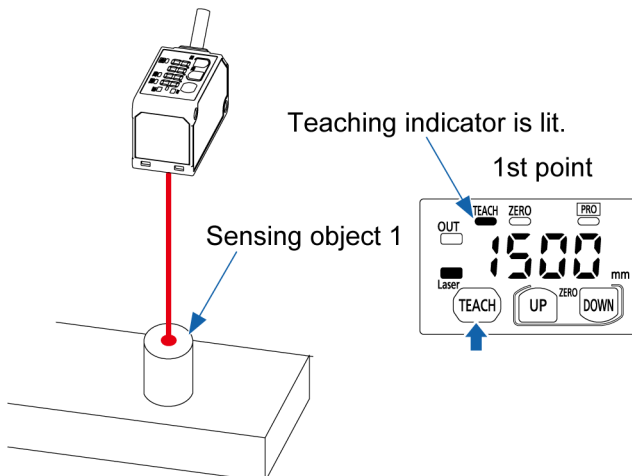

## 5.9 Sensing Output Setting (Teaching)

- "tch.2" will be displayed on the digital display every 1.5 seconds.



- Insert a sensing object 2 and press the TEACH key again. Teaching for the second point will be executed.

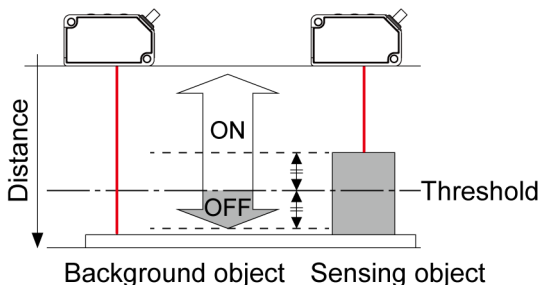

- The threshold value 1 and threshold value 2 will be set and teaching will be completed. If the difference between the teaching results for the sensing object 1 and sensing object 2 is equal to or larger than the shift amount, "good" will be displayed on the digital display. Then the desired threshold value is displayed and the teaching indicator turns OFF.

When stable sensing can be performed

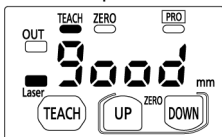

If the difference between the teaching results is less than the shift amount or if stable sensing cannot be performed, "Hard" will be displayed. Check the positional relationship between the sensing object 1 and sensing object 2 and perform teaching again.

When stable sensing cannot be performed

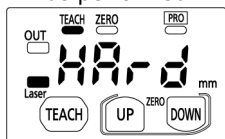

### 3-point Teaching

#### ■ Overview

This method is to perform teaching for the reference plane of the sensing object 1, sensing object 2, and sensing object 3 respectively. Here we call teaching results as "max.", "middle", and "min." in descending order.

The intermediate value between min. and middle is set as threshold value 1, and the intermediate value between middle and max. is set as the threshold value 2.



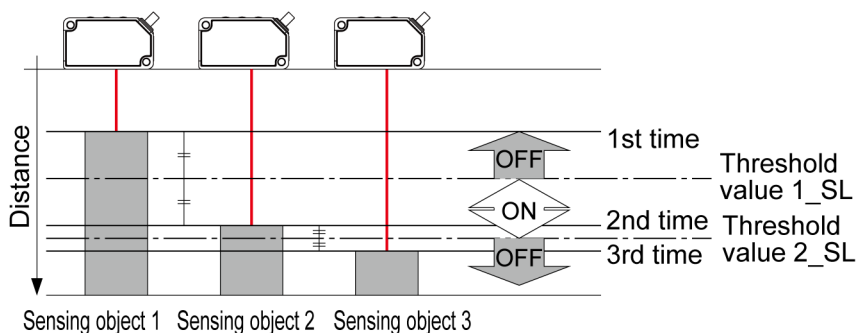

### 1 2 Procedure

1. With the sensing object 1 inserted, press the TEACH key.  
Teaching for the first point will be executed and the teaching indicator will be lit.

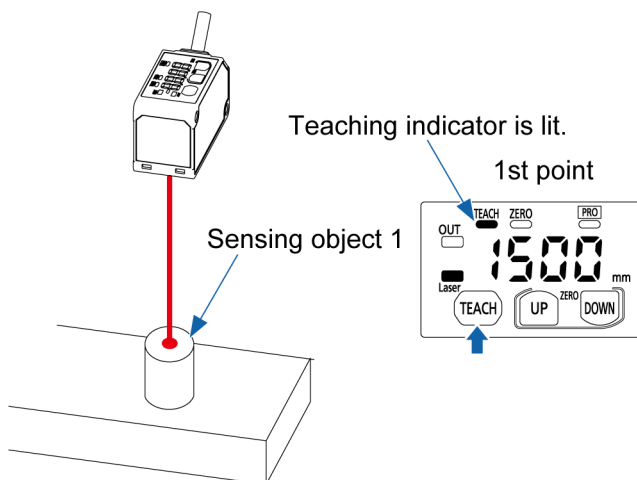

2. "tch.2" will be displayed on the digital display every 1.5 seconds.



3. Insert the sensing object 2 and press the TEACH key again.  
Teaching for the second point will be executed.

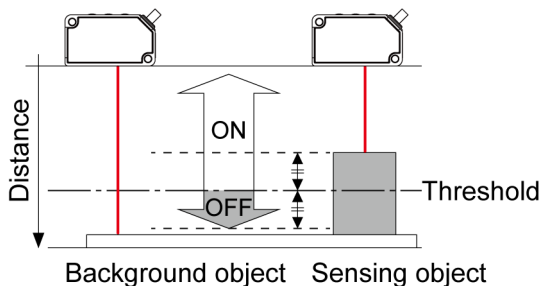

4. "tch.3" will be displayed on the digital display every 1.5 seconds.

## 5.9 Sensing Output Setting (Teaching)



5. Insert the sensing object 3 and press the TEACH key again. Teaching for the third point will be executed.

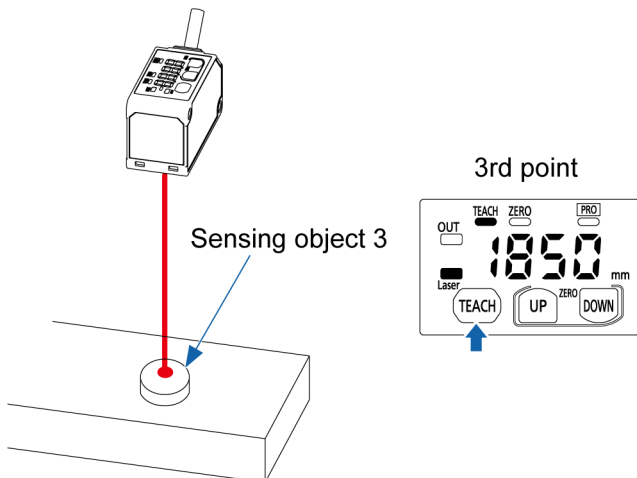

6. The threshold value 1 and threshold value 2 will be set and teaching will be completed. If the difference between the teaching results for the sensing objects 1 to 3 is equal to or larger than the shift amount, "good" will be displayed on the digital display. Then the desired threshold value is displayed and the teaching indicator turns OFF.

When stable sensing can be performed

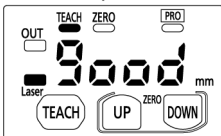

If the difference between the teaching results is less than the shift amount or if stable sensing cannot be performed, "Hard" will be displayed. Check the positional relationship among the sensing objects 1 to 3 and perform teaching again.

When stable sensing cannot be performed

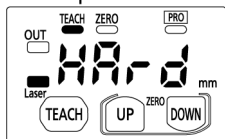

## 5.10 Analog Output Setting

### ■ Overview

This setting is used to select analog output as either analog voltage output or analog current output.

Output operation is performed for the selected output.

Set value	Output range	Function
Analog voltage output	0 to 5 V	Outputs a voltage according to the measured value.
Analog current output	4 to 20 mA	Outputs a current according to the measured value.

### ■ Setting method

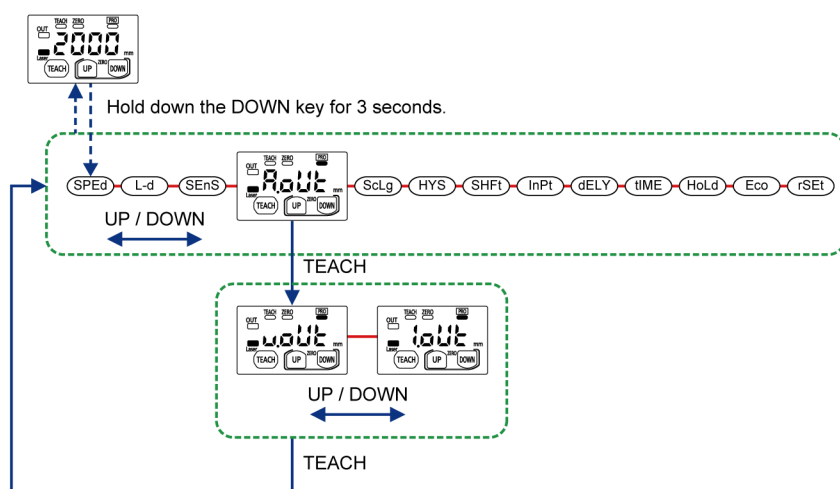

### Note

- Hold down the DOWN key for 3 seconds or longer on the setting screen, and the setting change is suspended and the screen returns to the measurement display.

Setting item	Set value	Default value
Analog output setting	Analog voltage output (v.out) Analog current output (I.out)	v.out

### 5.11 Analog Scaling Setting

#### ■ Overview

This setting is used to set optional two points as the upper limit value and the lower limit value for performing two-point correction on the analog output before data is output.

Set the measured value A (A.SCA) as the lower limit value and the measured value B (B.SCB) as the upper limit value.

The analog output measurement range is between 200 mm and 3,300 mm.

#### Analog voltage output (0 V to 5 V)

For the analog voltage output, set the measured value that outputs 0 V and the value that outputs 5 V and adjust the analog voltage output slope.

<Default setting>

Analog 0 V	0
Analog 5 V	3000

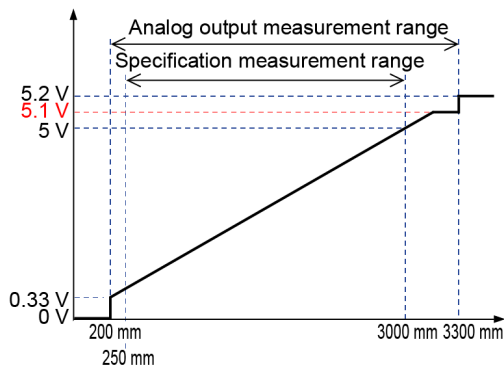

<When changing the setting (Example)>

Analog 0 V	1000
Analog 5 V	2000

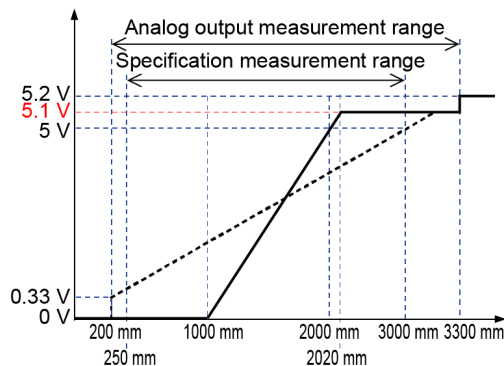

#### Note

- The output value for the analog output that is outside the measurement range is a fixed value.  
Less than 200 mm: 0 V  
More than 3,300 mm: 5.2 V
- When the analog output is within the measurement range, the output value is limited to 5.1 V and any value exceeding this value is not output.

#### Analog current output (4 mA to 20 mA)

For the analog current output, set the measured value that outputs 4 mA and the value that outputs 20 mA and adjust the analog current output slope.

<Default setting>

Analog 4 mA	0
Analog 20 mA	3000

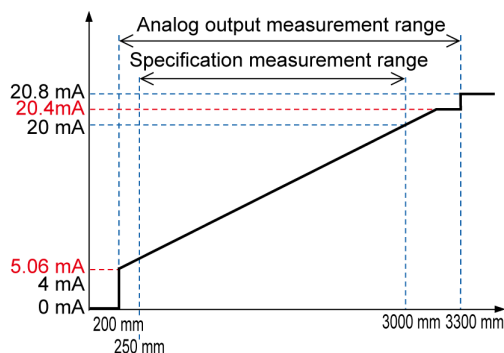

<When changing the setting (Example)>

Analog 4 mA	1000
Analog 20 mA	2000

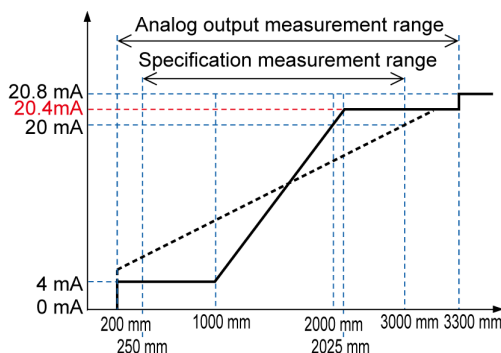

### Note

- The output value for the analog output that is outside the measurement range is a fixed value.  
Less than 200 mm: 0 mA  
More than 3,300 mm: 20.8 mA
- When the analog output is within the measurement range, the output value is limited to 20.4 mA and any value exceeding this value is not output.

## 5.11 Analog Scaling Setting

### ■ Setting method

#### Measured value A (lower limit) setting

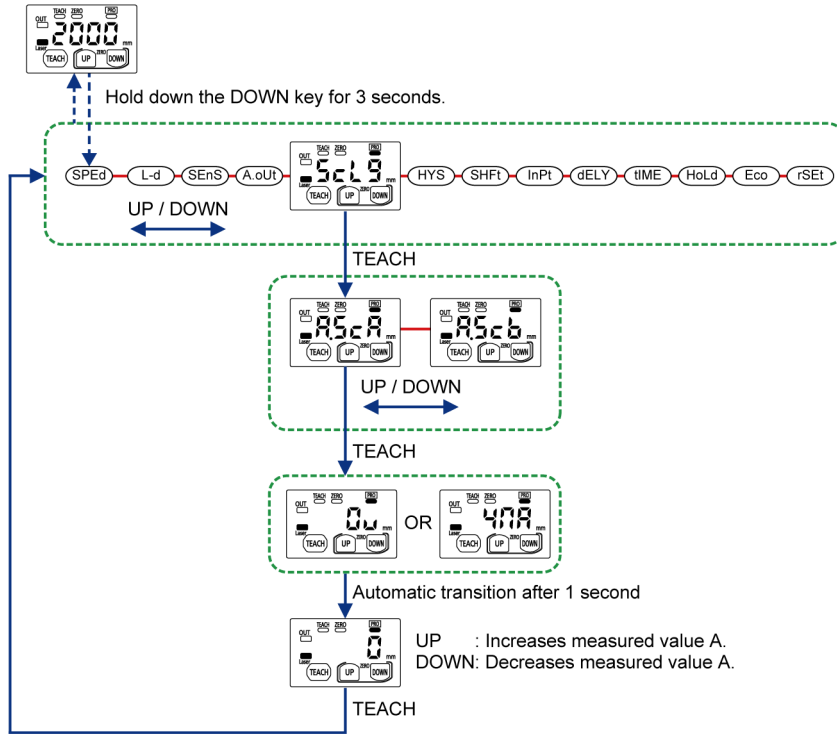

### Measured value B (upper limit) setting

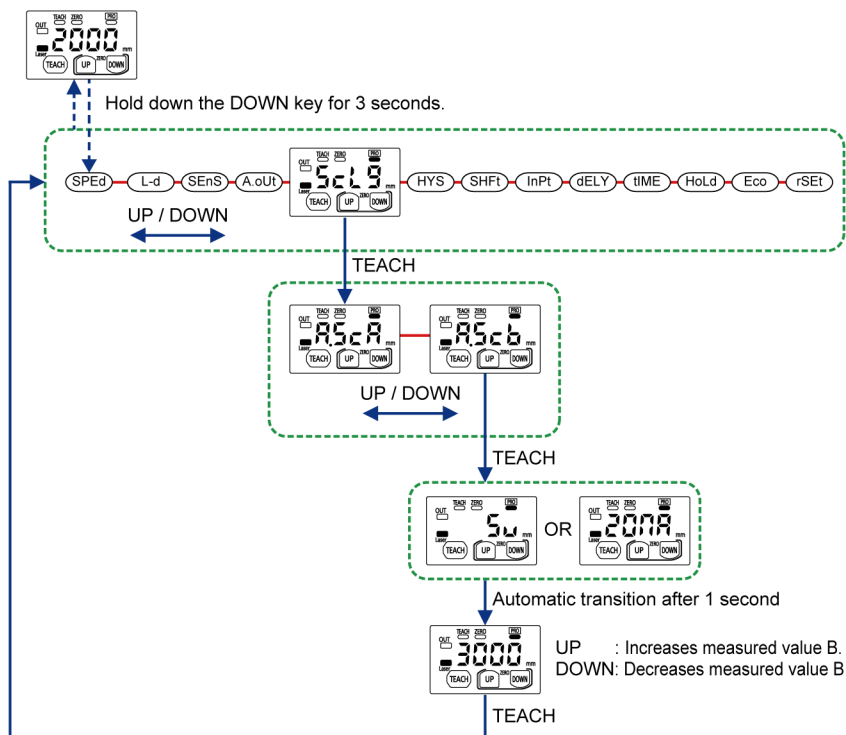

**Note**

- Be sure to set the measured values to be set so that the measured value B is larger than the measured value A.

Setting item	Set value		Setting range	Default value
Analog scaling	Measured value A (A.SCA)	0 V 4 mA	0 to 2,999	0
	Measured value B (A.SCB)	5 V 20 mA	250 to 3,000	3,000

## 5.12 Hysteresis Setting

### 5.12 Hysteresis Setting

#### ■ Overview

A hysteresis is the width of distance where the control output changes from OFF to ON or from ON to OFF.

When a sensing workpiece is located near the threshold value, increasing the value of hysteresis makes output operations stable.

#### ■ Setting method

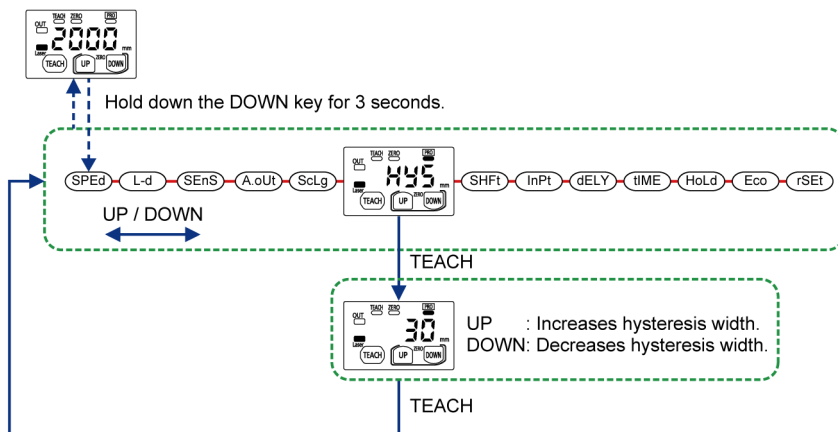

- The hysteresis cannot be set to a value that is equal to or greater than half of the shift amount.
- The hysteresis cannot be set to a value that is equal to or greater than the difference between the maximum displayable measured value (in consideration of the zero set setting state) and the threshold value.

#### ■ Note

- When making zero set setting, set the threshold value and then reset the hysteresis value as necessary.

Setting item	Set value	Default value
Hysteresis	1 to 1,500	30



## 5.13 Shift Amount Setting

### ■ Overview

This setting is used to set the shift amount when performing teaching.

This setting is enabled when the window comparator mode (1-point teaching) is executed.

### ■ Setting method

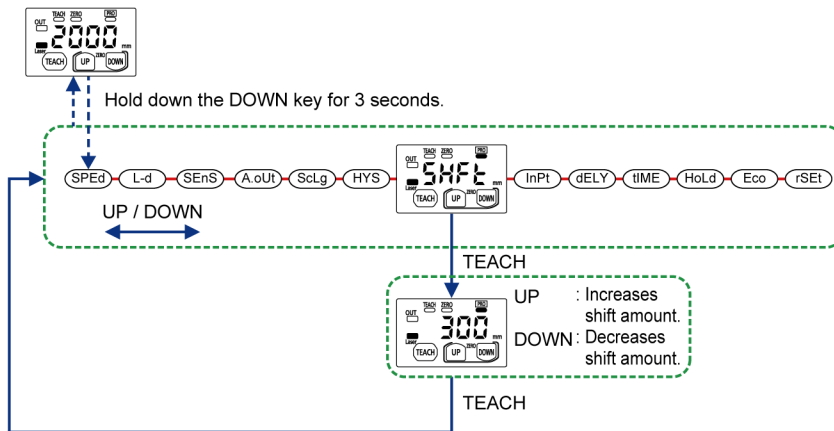

- It cannot be set to a value that is equal to or less than twice the hysteresis.



### Note

- If you keep holding down the UP key or DOWN key, the shift amount changes faster.

Setting item	Set value	Default value
Shift amount	2 to 3,000	60

## 5.14 External Input Setting

■ **Overview**

This setting is used to execute the following three functions by controlling the external input.

■ **Setting method**

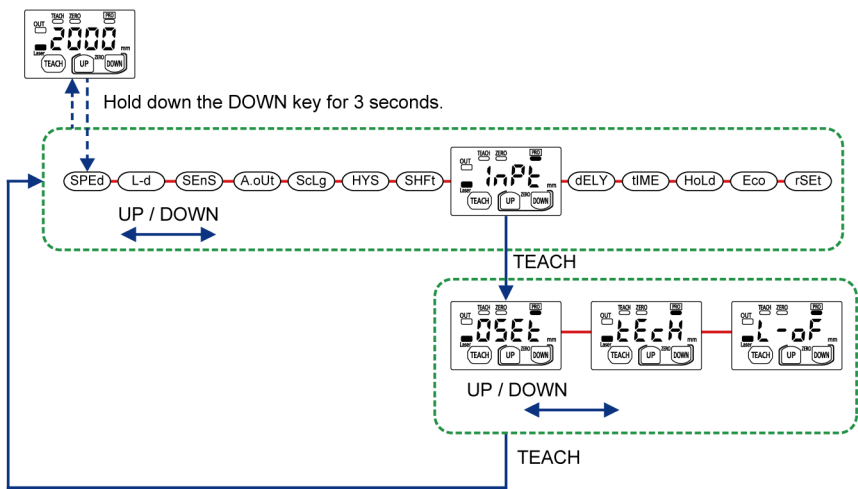

**Note**

- Hold down the DOWN key for 3 seconds or longer on the setting screen, and the setting change is suspended and the screen returns to the measurement display.

Setting item	Set value	Default value
External input setting	Zero setting (0SEt) Teaching (tEcH) Emission stop function (L-oF)	0SEt

### 5.14.1 Zero Setting

This function is used to forcibly set the measured value to “zero”.

- Using the external input, keep the zero set to ON for 15 ms or longer and then change it from ON to OFF to execute zero setting ON.
- When changing the zero set from ON to OFF, turn the external input ON and, after an elapse of 1,000 ms, execute zero setting OFF.
- The timing chart for setting or clearing the zero setting using the external input is as shown in the following diagram.

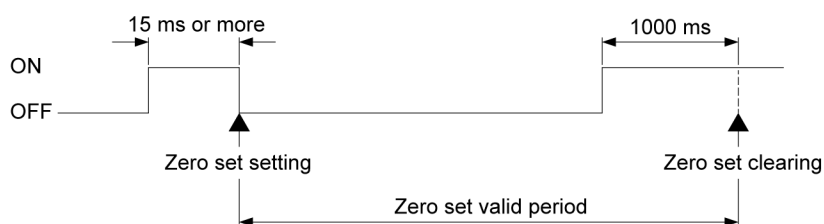

### Note

- The zero set that is set using the external input is cleared when the power supply is turned OFF. The zero set made at that time is not saved.
- Even when the zero set is set on the sensor side, it can be set or cleared using the external input. However, the zero set on the sensor side is not cleared. When the power supply is turned on again, the zero set that is set on the sensor side will be displayed.
- When zero setting is performed during teaching, using the external input, teaching becomes unstable.

## 5.14.2 Teaching

This setting is used to execute teaching by controlling the external input in the same manner as when the TEACH key is pressed.

- For details on teaching, refer to "[5.9 Sensing Output Setting \(Teaching\)](#)".
- The timing chart for executing teaching using the external input is as shown in the following diagram.

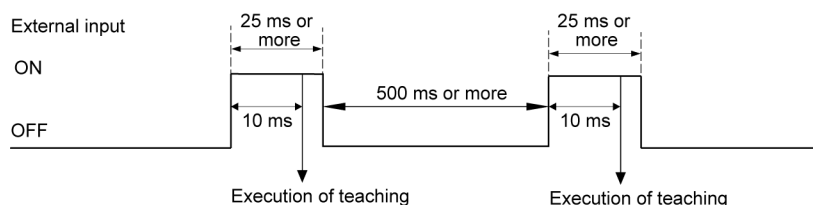

### Note

- Limit teaching cannot be executed by the external input alone.
- Teaching using the external input is not accepted in the PRO mode.

## 5.14.3 Emission Stop

This setting is used to turn ON or OFF the emitted laser beam using the external input.

### Emission stop

- The emitted laser beam can be turned OFF by turning ON the external input from OFF. The laser radiation indicator is also unlit when the emitted laser beam is turned OFF.

## 5.14 External Input Setting

---

- The emitted laser beam is turned ON when the external input is turned OFF from ON. The laser radiation indicator is lit when the emitted laser beam is turned ON.
- The timing chart for stopping or clearing the emission using the external input is as shown in the following diagram.

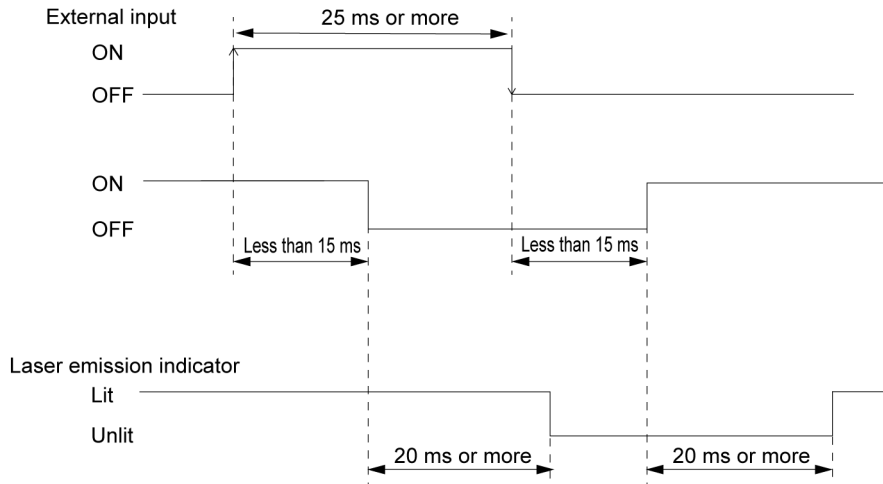

### Note

- If the external input time is short, the lit / unlit state of the indicator may not match the emission state.
- When emission stop is performed during teaching, a teaching error occurs.

## 5.15 Timer Setting

### ■ Overview

This setting is used to set the control output timing from ON to OFF or from OFF to ON.

Set value	Operation
OFF (No timer)	No change is made in the control output timing.
Off delay	When the control output is turned OFF from ON, delays the OFF output for the timer's time.
On delay	When the control output is turned ON from OFF, delays the ON output for the timer's time.
One-shot	When the control output is turned ON from OFF, holds the ON output for the timer's time and then outputs OFF output.

### 📄 Note

- When the timer is set or the timer's time is changed during output delay operation, the changed set value is reflected when the output is changed next time.

### ■ Setting method

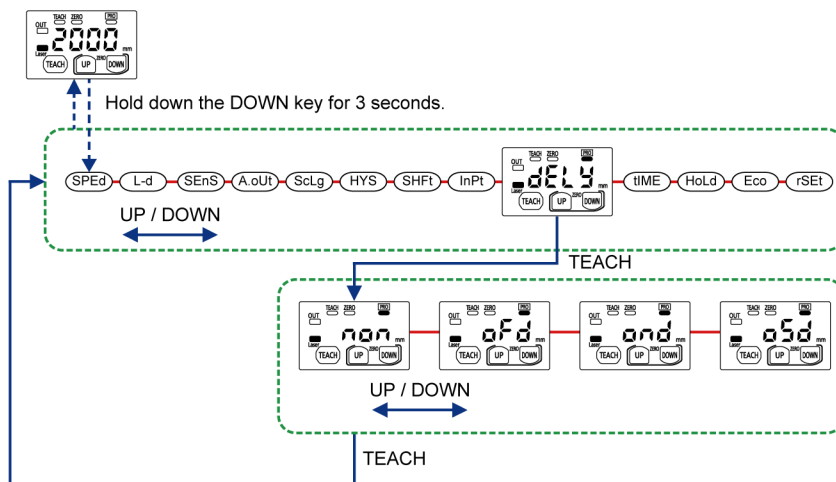

### 📄 Note

- If you do not make key operation for 3 seconds after changing the threshold value, the changed value is set as a new threshold value and the screen returns to the measurement display.

Setting item	Set value	Default value
Timer setting	OFF (non) OFF delay (oFd) ON delay (ond) One-shot (oSd)	non

## 5.15 Timer Setting

### ■ OFF (No timer)

When the output operation setting is set to light-ON and the sensing output setting is set to normal sensing, the control output will be as shown in the following diagram.

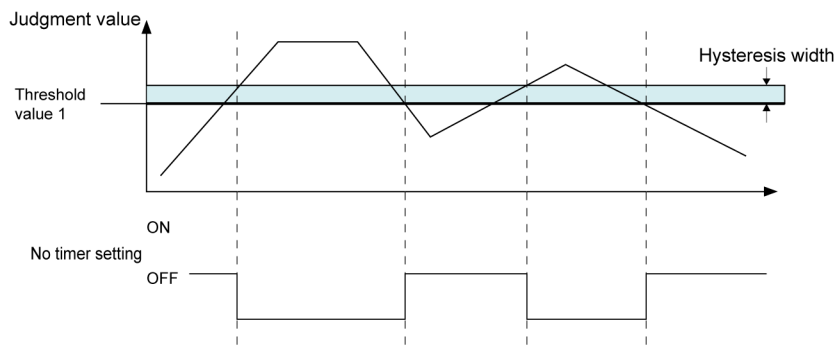

### OFF delay

When the timer is set to OFF delay, the output is delayed for the timer's time set for the OFF timing. If the OFF duration is less than the timer's time, the delay does not appear in the control output.

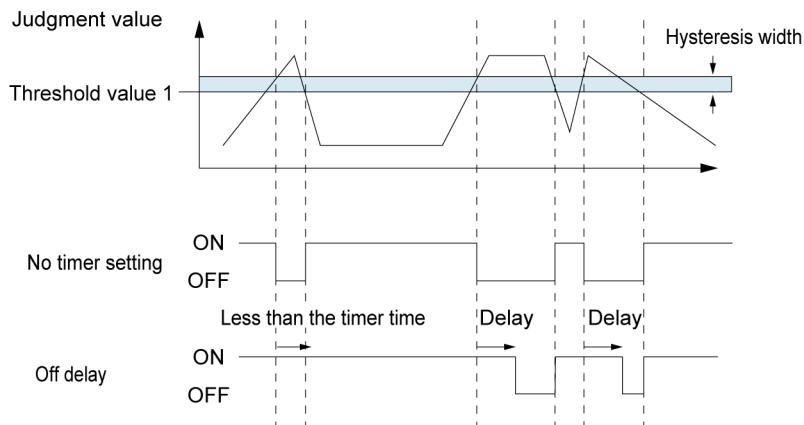

### ON delay

When the timer is set to ON delay, the output is delayed for the timer's time set for the ON timing. Therefore, if the ON duration is less than the timer's time, the delay does not appear in the control output.

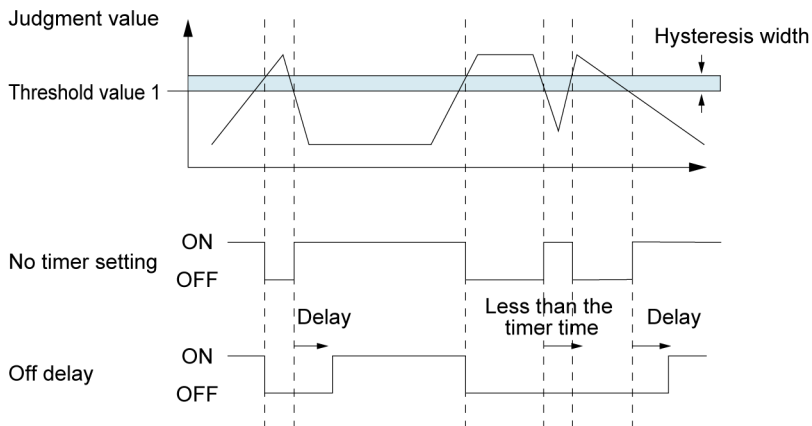

**One-shot**

When the timer is set to one-shot and if the setting is changed from OFF to ON again while ON is held, the ON time is extended by the timer's time.

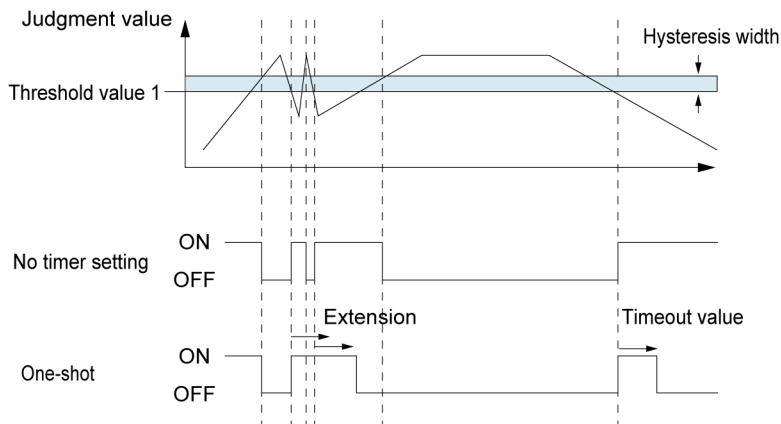

## 5.16 Timer Time Setting

### 5.16 Timer Time Setting

#### ■ Overview

This setting is used to set the timer time (unit: ms) when "OFF delay timer", "ON delay timer", or "One-shot timer" is set in the timer setting.

This setting is enabled when "5.15 Timer Setting" is executed.

#### ■ Setting method

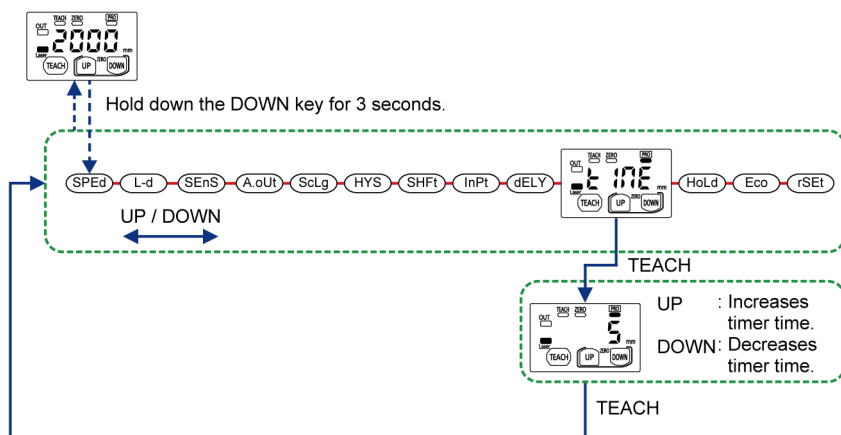

#### ■ Note

- The set timer time value is shared by all timer settings.
- Hold down the DOWN key for 3 seconds or longer on the setting screen, and the setting change is suspended and the screen returns to the measurement display.

Setting item	Set value	Default value
Timer time setting	5	5
	10	
	25	
	50	
	100	
	250	
	500	
	1,000	
5,000		





## 5.17 Hold Setting

---

Setting item	Set value	Default value
	Hold last value (on)	

## 5.18 ECO Setting

### ■ Overview

This setting is used to turn OFF the digital display to save electricity when not operating.

If the ECO mode is set to ON, the digital display will turn OFF when no key is operated for 30 seconds.

If you press any key while the digital display is OFF, it turns ON again.

### ■ Setting method

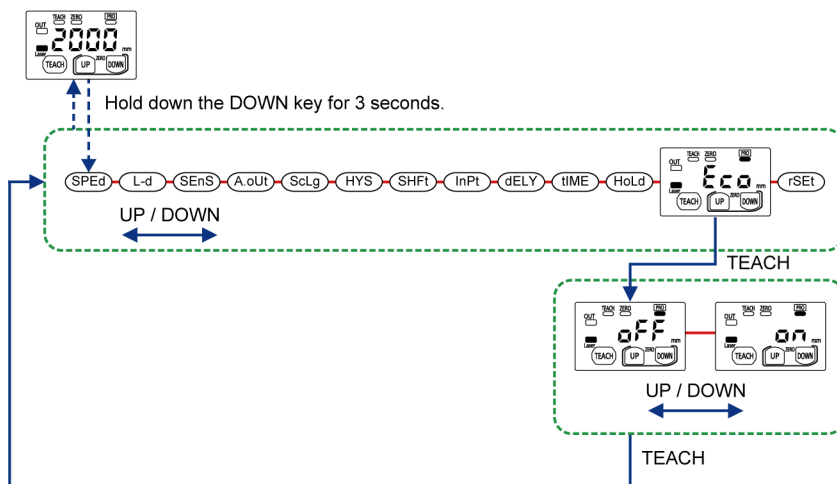

### 📌 Note

- Hold down the DOWN key for 3 seconds or longer on the setting screen, and the setting change is suspended and the screen returns to the measurement display.

Setting item	Set value	Default value
ECO setting	ECO OFF (oFF) ECO ON (oN)	oFF

## 5.19 Reset Setting

### ■ Overview

This setting is used to reset all the settings of this product to the factory default settings. For the default value of each setting, refer to "5.1 List of Setting Items".

### ■ Setting method

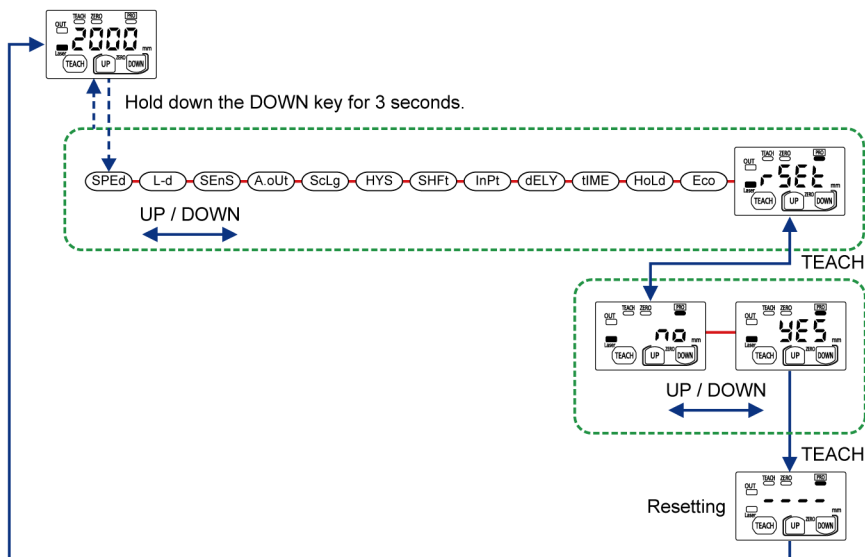

### 📌 Note

- Hold down the DOWN key for 3 seconds or longer on the setting screen, and the setting change is suspended and the screen returns to the measurement display.

Setting item	Set value	Default value
Reset setting	Reset NG (no) Reset OK (YES)	no

# 6 Maintenance

---

6.1 Maintenance and Inspection .....	6-2
6.1.1 Maintenance Precautions .....	6-2
6.1.2 Main Inspection Items .....	6-2

## 6.1 Maintenance and Inspection

---

### 6.1 Maintenance and Inspection

#### 6.1.1 Maintenance Precautions

- Be sure to turn off the power before cleaning the light emitting and receiving windows of the sensor.
- When cleaning the light emitting and receiving windows of the sensor, wipe them with a lint-free soft cloth or lens cleaning paper.
- Never use thinner, benzene, or other organic solvents to wipe off dirt or dust.

#### 6.1.2 Main Inspection Items

Inspect the sensor regularly to maintain performance and enable optimum use.

The main inspection items are as follows:

- Is the product installation loose?
- Have any input and output terminals become loose or come off?
- Are there cracks in the cable ?
- Is the spot beam deviated from the set position?
- Is the supplied power within the rated voltage range (24 VDC  $\pm$ 10 %)?
- Is the ambient temperature within the specified range (-10 to +45°C)?
- Is the ambient humidity within the specified range (35 to 85% RH)?
- Are the light emitting and receiving windows of the sensor contaminated with dirt or foreign matter?

# 7 Troubleshooting

---

7.1 Solutions to Problems .....	7-2
7.2 Error Display .....	7-3

## 7.1 Solutions to Problems

### 7.1 Solutions to Problems

Solutions to frequently encountered problems and errors are described below.

#### Note

- Check the wiring.
- Check the voltage and capacity of the power supply.

Symptom	Cause	Solution	Reference page
Nothing appears on the digital display	Power is not supplied.	Check if the capacity of the power supply is sufficient. Connect the power supply correctly.	"P.8-2"
	ECO mode is ON.	Set ECO mode to OFF.	"P.5-43"
Measured value is not displayed correctly	Laser emission stop input is ON.	Set laser emission stop input to OFF.	"P.5-35"
	The measurement object is not within the measurement range.	Check if the measurement object is within the measurement range.	-
	Obstacles exist within the measurement range.	Remove the obstacles.	-
	The hold function is ON.	Check the settings of the hold function.	"P.5-41"
	The sensor is not installed correctly.	Install the sensor correctly.	"P.3-2"
	Dust, dirt, or other foreign matter adheres to the light emitting and receiving windows of the sensor.	With a lint-free soft cloth or lens cleaning paper, wipe off any dirt that adheres to the light emitting and receiving windows of the sensor.	-
	Dust, dirt, or other foreign matter adheres to the measurement object.	Remove any dust, dirt, or other foreign matter that adheres to the sensing object.	-
	Dust, grit, or other substances are attached to the operating environment.	Use a dust collector or similar device to remove and prevent dust, grit, and other substances from flying in the operating environment.	-
Measured value is not displayed stably	The distance between the sensor and the measured object is too far.	Ensure that the distance between the installed sensor and the sensing object is within the specified range.	"P.8-2"
	The sensor is installed in a location subject to severe vibration.	Take measures against vibration.	-
Analog output is not generated correctly	Analog output line is not wired correctly.	Wire the analog output line correctly.	"P.3-4"
Keys cannot be operated	The key lock function is ON.	Set the key lock function to OFF.	"P.5-13"

#### Important

If the product still does not operate normally after you check the above, consult your Panasonic representative.



## 7.2 Error Display

If an error occurs during setting or measurement, one of the error codes listed below will be displayed on the digital display.

Error code	Description	Remedy
E-01	Internal memory is abnormal, damaged, or has passed its life expectancy.	<ul style="list-style-type: none"> <li>Switch the power OFF and then ON, and select and execute the reset setting (initialization of this product) from setting items.</li> <li>If the sensor does not recover after the above action, consult your Panasonic representative.</li> </ul>
E-11	Control output load has short-circuited and excessive current is flowing.	Turn OFF the power and check the load.
E-31	During zero setting, the measurement is not performed properly.	Check if the sensing distance to be set is within the specification range.
E-41	During teaching, the measurement is not performed properly.	Check if the sensing distance to be set is within the specification range.
E-51	The beam emitting part or the beam receiving part is abnormal.	Turn the power OFF and then ON. If the sensor does not recover after the above action, consult your Panasonic representative.
E-90	System error	The product could be faulty. Please consult your Panasonic representative.
E-91		
E-92		
E-93		
E-94		
E-95		
E-96		

### Important

If an error occurs again after you cleared it, consult your Panasonic representative.

(MEMO)

# 8 Specifications and Dimensions

---

8.1 Specifications.....	8-2
8.2 Shapes and Dimensions.....	8-5
8.2.1 Products.....	8-5
8.2.2 Simple Mounting Bracket ( <b>MS-HG-01: Including two M3 screws with washer</b> ).....	8-6
8.2.3 Simple Mounting Bracket Attachment Diagram.....	8-7
8.3 I/O Circuit Diagrams.....	8-8

## 8.1 Specifications

### 8.1 Specifications

Model No.		HG-F13A-A-N NPN output type	HG-F13A-A-P PNP output type
Power supply voltage		24 VDC $\pm$ 10%, including 10% ripple (P-P)	
Current consumption (Note 2)		40 mA or less (at the power supply voltage of 24 VDC)	
Control output	Output type	NPN open-collector transistor	PNP open-collector transistor
	Applied voltage	30 VDC (between output and 0 V)	30 VDC (between output and +V)
	Residual voltage	1.5 V or less (at 50 mA source current)	
	Maximum sink current / source current	Maximum sink current: 50 mA	Maximum source current: 50 mA
	Leakage current	0.1 mA or less	
	Output operation	Light-ON (L-on) / dark-ON (d-on) Selectable (Default: Light-ON (L-on))	
	Short-circuit protection	Incorporated (automatic reset type)	
Analog output		Voltage output / current output, selectable (Default: Voltage output)	
Analog voltage output	Output range (Note 3)	In normal condition: 0 V to +5 V Possible to set the distance range (Default: 250 to 3,000 mm) When alarm occurs: Last value is held or the range is set to 0 V on the near point side and to +5.2 V on the far point side.	
	Output impedance	100 $\Omega$	
Analog current output	Output range (Note 3)	In normal condition: +4 mA to +20 mA Possible to set the distance range (Default: 250 to 3,000 mm) When alarm occurs: Last value is held or the range is set to 0 mA on the near point side and to +20.8 mA on the far point side.	
	Load resistance	250 $\Omega$ or less	
External input	Input conditions	Disabled: 8 to +VDC or open Enabled: 0 to 1.2 VDC	Disabled: 0 to 0.6 VDC or open Enabled: 4 to + VDC
	Input impedance	Approx. 10 k $\Omega$	
External input function		Zero set / Teaching / Emission stop Selectable (Default: Zero set)	

## 8.1 Specifications

Model No.		HG-F13A-A-N NPN output type	HG-F13A-A-P PNP output type
Sensing distance (displayable distance)	Maximum sensing distance	3,000 mm	
	Measurable range	250 to 3,000 mm	
	Displayable range (Note 4)	200 to 3,300 mm	
Linearity		± 2% F.S. (Note 5) (at 500 mm to 3,000 mm)	
Light source		Red semiconductor laser: Class 1 [JIS / IEC / GB / FDA (Note 6)] Maximum output: 0.39 mW, Peak emission wavelength: 680 nm	
Beam diameter (Note 7)		Approx. ø10 mm or less (typical) (at the setting distance of 1,000 mm)	
Repeatability		10 mm or less	
Hysteresis		30 mm (default setting) Possible to vary up to 1 mm minimum in the PRO mode (Note 8)	
Temperature characteristics		0.1% F.S./°C	
Response time		35 ms, 100 ms, 300 ms, or 2,000 ms Selectable (Default: 100 ms)	
Indicators	Laser radiation	Green light emitting diode: Lit while laser beams are being emitted.	
	Output operation	Orange light emitting diode: Lit while output is ON.	
	Teaching	Yellow light emitting diode: Lit while teaching is in progress.	
	Zero setting	Yellow light emitting diode: Lit while the zero set is enabled.	
	PRO mode	Yellow light emitting diode: Lit while the PRO mode is in progress.	
Digital display		Red light emitting diode: Displays a code and 4-digit number.	
Teaching function		Normal sensing mode (2-point/limit) or window comparator mode (1-point / 2-point / 3-point) Selectable (Default: Normal sensing mode)	
Timer function		OFF / ON delay / OFF delay / One-shot Selectable (Default: OFF)	
Timeout value		5 ms / 10 ms / 25 ms / 50 ms / 100 ms / 250 ms / 500 ms / 1,000 ms / 5,000 ms Selectable (Default: 5 ms)	
Pollution degree		2	
Overvoltage category		Category I	
Insulation resistance		20 MΩ or higher, using 250 VDC megger (between all supply terminals and casing)	
Withstand voltage		500 VAC for one minute (between all supply terminals and casing)	

## 8.1 Specifications

Model No.	HG-F13A-A-N NPN output type	HG-F13A-A-P PNP output type
Operating altitude (Note 9)	2,000 m or less	
Various settings	Emitted beam spot check mode / Threshold fine adjustment / Threshold selectable / Peak/bottom hold function / Zero set function / Key lock function / Response time setting / Output operation setting / Sensing output setting (teaching) / Analog output setting / Analog scaling setting / Hysteresis setting / Shift amount setting / External input setting / Timer setting / Timer time setting / Hold setting / ECO setting / Reset setting	
Protective structure	IP67 (IEC)	
Ambient operating temperature	-10 to +45 °C (No condensation or icing), Storage: -20 to +60 °C	
Ambient operating humidity	35% to 85% RH, Storage: 35% to 85% RH	
Ambient illuminance	Incandescent light: 3,000 lx or less at the light-receiving face	
Vibration resistance	Durability: 10 to 55 Hz (cycle: 1 minute) with 1.5 mm amplitude in X, Y, and Z directions for two hours each (with no power supply)	
Shock resistance	Durability: 500 m/s <sup>2</sup> (approx. 50 G) in X, Y and Z directions three times each (with no power supply)	
Cable	0.2 mm <sup>2</sup> 5-conductor 2 m composite cable	
Cable extension	Extension up to total 10 m is possible with a cable of 0.3 mm <sup>2</sup> or more.	
Materials	Casing: Aluminum die casting, Front cover: Acrylic, Cable: PVC	
Weight	Approx. 85 g, approx 130 g (when packaged)	

- (Note 1) Unless otherwise specified, measurement conditions are as follows: Power supply voltage of 24 VDC, ambient temperature of +20°C, response time of 100 ms, and measurement distance of 1,000 mm. The target object is a 200 mm × 200 mm white matte paper. Perform measurement 30 minutes after turning on the power supply.
- (Note 2) Analog output is not included.
- (Note 3) When the intensity of received light is unstable, the voltage is output as 0 V and the current is output as 0 mA.
- (Note 4) When an object is detected, the range of numerical values that appear on the digital display is regarded as the displayable distance.  
When zero setting is performed, the displayable distance varies depending on the zero setting distance.
- (Note 5) F.S. (full scale) represents a range from 0 mm to 3,000 mm.
- (Note 6) This product complies with the FDA regulations (FDA 21 CFR 1040.10 and 1040.11) in accordance with FDA Laser Notice No. 56, except for complying with IEC 60825-1 Ed. 3.
- (Note 7) The beam diameter is defined as  $1/e^2$  (approx. 13.5 %) of the center light intensity. Due to leak light outside the defined range, the measurement values may be affected if the reflectance around the detecting point is higher than that of the detecting point.
- (Note 8) Changing the hysteresis may result in unstable sensing. After making a change, perform operation check using actual equipment.
- (Note 9) Do not use or store this product in environments where ambient air is pressurized to an air pressure higher than the atmospheric pressure at an altitude of 0 m.

**8.2 Shapes and Dimensions**

**8.2.1 Products**

**HG-F13A-A-N, HG-F13A-A-P**  
Units: mm

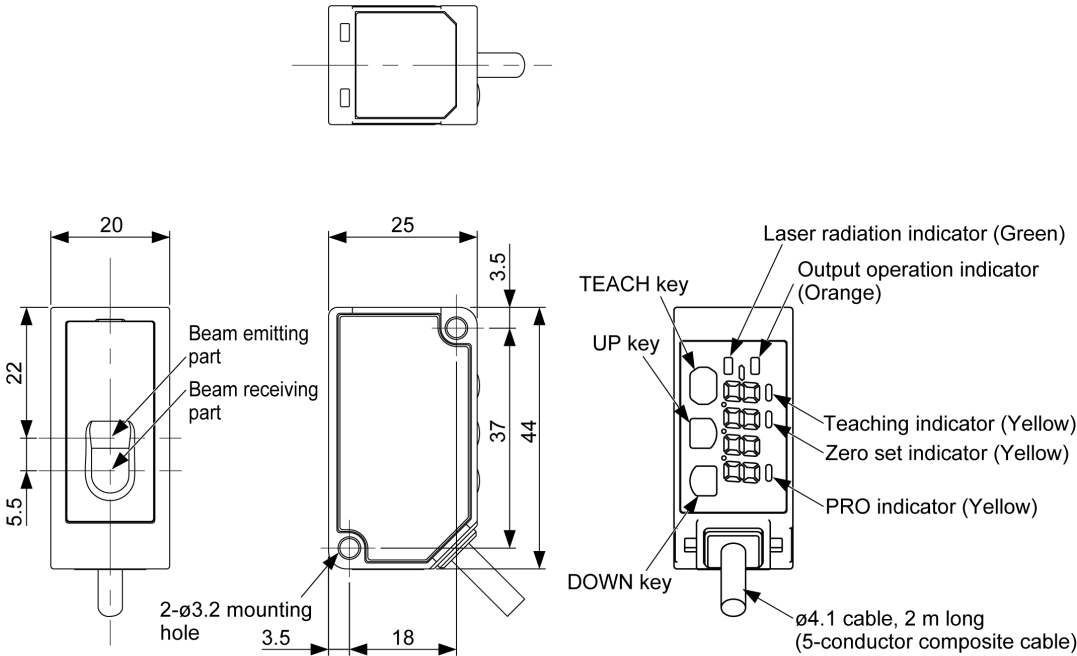

TOLERANCE OF CABLELENGTH	
TOTAL LENGTH	TOLERANCE
1000 OR LESS	+20% OF TOTAL LENGTH -0
OVER 1000 TO 2000 INCL.	+200 -0
OVER 2000	+20% OF TOTAL LENGTH -0

TOLERANCE	
6 AND UNDER	±0.3
OVER 6 TO 30 INCL.	±0.4
OVER 30 TO 120 INCL.	±0.8
OVER 120 TO 315 INCL.	±1.2
OVER 315 TO 630 INCL.	±1.8
OVER 630 TO 1000 INCL.	±2.5

## 8.2 Shapes and Dimensions

### 8.2.2 Simple Mounting Bracket (MS-HG-01: Including two M3 screws with washer)

Units: mm

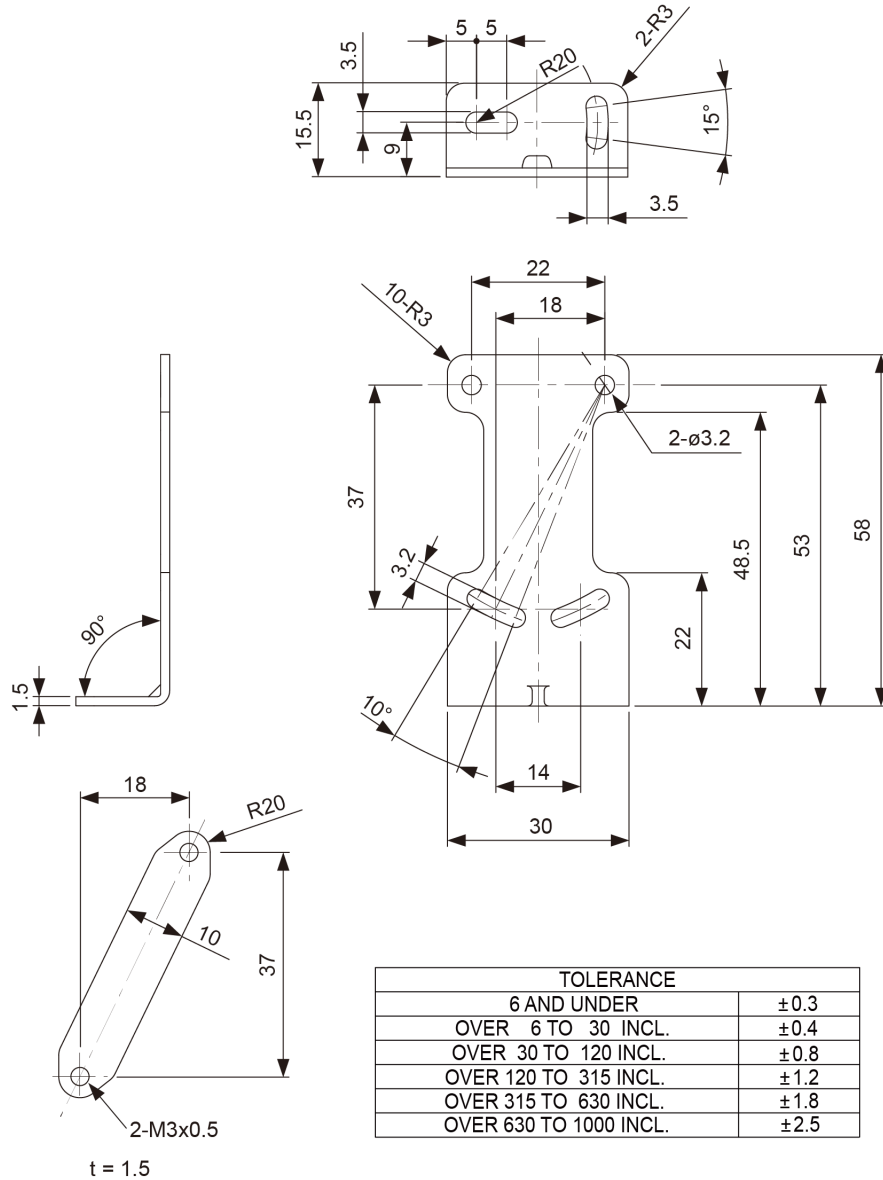



**8.2.3 Simple Mounting Bracket Attachment Diagram**

Units: mm

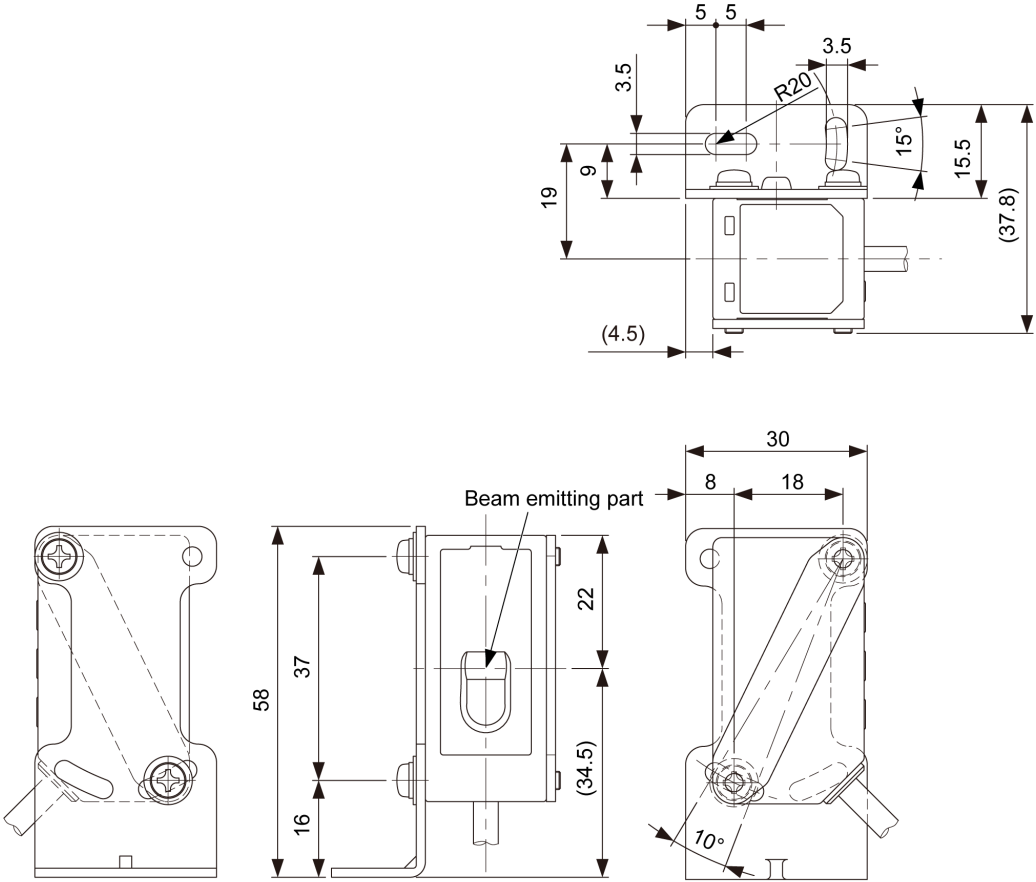

TOLERANCE	
6 AND UNDER	±0.3
OVER 6 TO 30 INCL.	±0.4
OVER 30 TO 120 INCL.	±0.8
OVER 120 TO 315 INCL.	±1.2
OVER 315 TO 630 INCL.	±1.8
OVER 630 TO 1000 INCL.	±2.5

**8.3 I/O Circuit Diagrams**

**HG-F13A-A-N / NPN type**

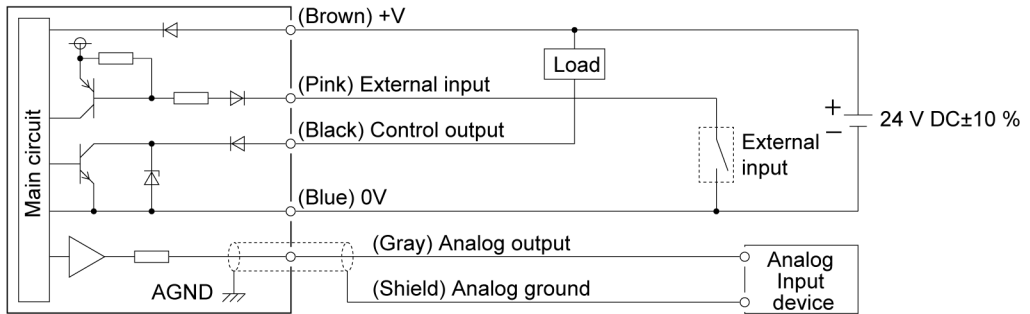

**HG-F13A-A-P / PNP type**

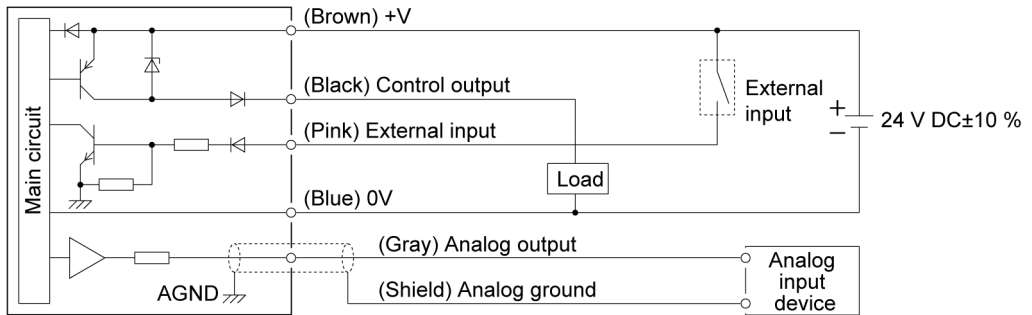

(Note 1) Insulate unused terminals to avoid error input or short circuit.

# Appendix Screen Transition List

---

Screen Transition List .....App-2

## Screen Transition List

### ■ Emitted beam spot check mode

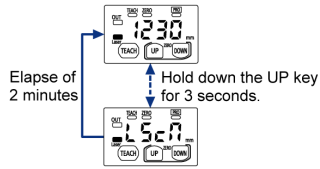

### ■ Peak / bottom hold function

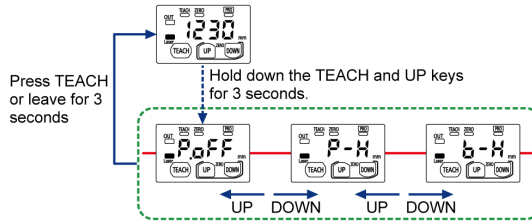

### ■ Zero set function

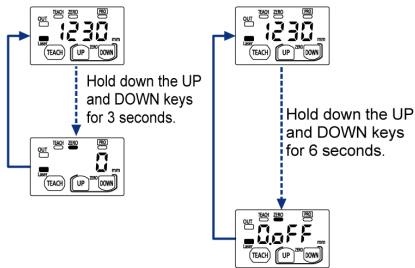

### ■ Key lock function

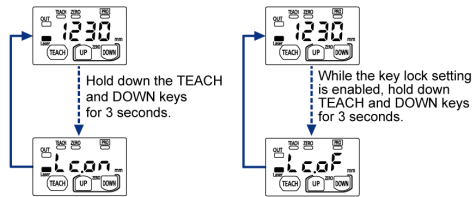

### ■ PRO mode

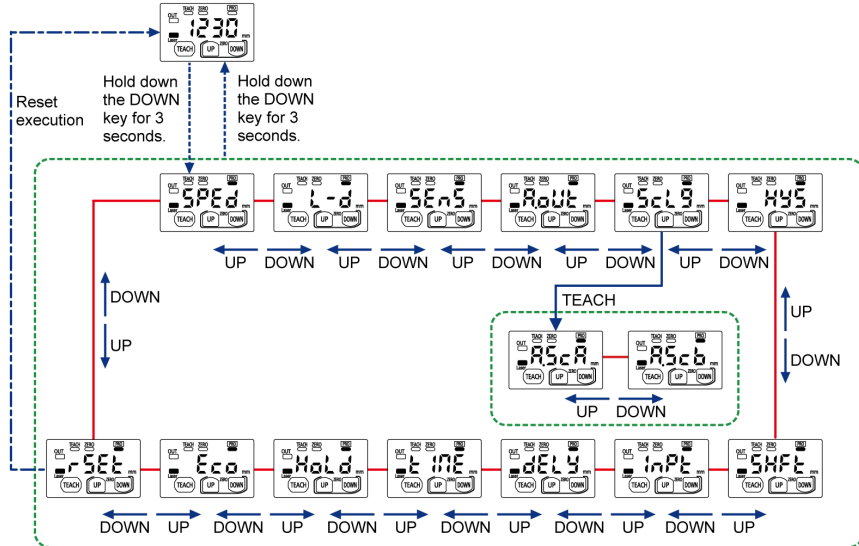

## Revision History

Revision history	Revision date	Revision item
1st edition	December 2022	-
2nd edition	February 2023	Corrected caution notes to "1.5 Regulations and Standards" Deleted "Applicable regulations and certification" in "8.1 Specifications" Deleted "Important Information about Order and Use of This Product"
3rd edition	April 2023	Added "1.4 Open Source Software (OSS)" Added "1.4.1 Copyright·License" Corrected errors "8.1 Specifications"

(MEMO)

(MEMO)

---

**Panasonic Industry Co., Ltd.**  
**Panasonic Industrial Devices SUNX Co., Ltd.**  
<https://panasonic.net/id/pidsx/global>

Please visit our website for inquiries and about our sales network.

**Panasonic Industrial Devices SUNX Co., Ltd. 2023**  
April 2023

WUME-HGF1UM-3