

Laser Displacement Sensor

HL-G2 Series

# User's Manual

Analog Output Type

(MEMO)

## Introduction

Thank you for purchasing Laser Displacement Sensor **HL-G2** Series.

Before using this product, read and understand this User's Manual. Use the product correctly and in the optimum manner.

Keep this manual in a safe location for reference whenever necessary.

## Types of Manuals

- There are different types of user's manual for the **HL-G2** series, as listed below. Refer to the appropriate manual according to your need.
- These manuals can be downloaded from our website: [https://industrial.panasonic.com/ac/e/dl\\_center/manual/](https://industrial.panasonic.com/ac/e/dl_center/manual/).

Type of sensor / Software name	Manual name	Manual code
Communication type HL-G2	HL-G2 Series User's Manual (Communication Type)	WUME-HLG2CM
Analog output type HL-G2	HL-G2 Series User's Manual (Analog Output Type)	WUME-HLG2AN
Tool software for the HL-G2 series HL-G2 Configuration Tool	HL-G2 Configuration Tool User's Manual	WUME-HLG2CT

## Manual Configuration

Chapter 1	Before Using This Product	This chapter explains safety and handling precautions, laser safety standards, component names, and other information that should be checked before using this product.
Chapter 2	System Configuration	This chapter explains the system configuration.
Chapter 3	Installation and Setup	This chapter explains installation, connection, wiring, initial startup setting, and other work.
Chapter 4	Description of Functions	This chapter explains details and settings for various functions.
Chapter 5	Maintenance	This chapter explains maintenance and inspection.
Chapter 6	Troubleshooting	This chapter explains how to take action when problems occur.
Chapter 7	Specifications and Dimensions	This chapter explains the specifications and dimensions.

(MEMO)



# Table of Contents

<b>1 Before Using This Product.....</b>	<b>1-1</b>
1.1 Safety Precautions (Always observe) .....	1-2
1.2 Handling Precautions.....	1-3
1.2.1 Explanation of Graphic Symbols .....	1-3
1.2.2 Handling Precautions .....	1-3
1.3 Terminology.....	1-6
1.4 Regulations and Standards .....	1-7
1.5 Conditions for Compliance with CE Marking/UKCA Marking.....	1-8
1.6 Laser Safety Standards .....	1-9
1.6.1 IEC / EN / JIS / GB / KS .....	1-9
1.6.2 FDA.....	1-10
1.7 Contents of Package.....	1-11
<b>2 System Configuration.....</b>	<b>2-1</b>
2.1 System Configuration Diagram .....	2-2
2.2 Description of Parts.....	2-3
<b>3 Installation and Setup.....</b>	<b>3-1</b>
3.1 Flow of Operations up to Measurement Startup .....	3-2
3.2 Sensor Installation .....	3-3
3.3 Sensor Installation Direction and Angle .....	3-4
3.4 Optional Cable Connection Method .....	3-7
3.5 Functions and Wiring of I/O Lines.....	3-9
3.5.1 Grounding .....	3-12
3.5.2 Precautions for positive ground environment.....	3-13
3.6 Initial Startup Settings .....	3-14
<b>4 Description of Functions.....</b>	<b>4-1</b>
4.1 List of Functions.....	4-3
4.2 Bank Switching .....	4-6
4.3 Sensing Setting.....	4-8
4.3.1 Sampling Frequency .....	4-8
4.3.2 Average Times .....	4-10
4.3.3 Brightness Tuning .....	4-12
4.3.4 Hold Mode.....	4-15
4.3.5 Inversion of Measured Value.....	4-19
4.3.6 Span.....	4-21
4.3.7 Offset.....	4-23
4.4 Judgment Setting .....	4-25
4.4.1 HIGH Set Value.....	4-25
4.4.2 LOW Set Value.....	4-29
4.4.3 Hysteresis .....	4-33

4.4.4 Teaching Mode.....	4-35
4.4.5 Tolerance .....	4-37
4.5 Output Setting .....	4-39
4.5.1 Judgment Output .....	4-39
4.5.2 Output Delay Timer Selection .....	4-41
4.5.3 Output Delay Timer Setting .....	4-45
4.5.4 Output Type .....	4-46
4.5.5 Analog Output .....	4-47
4.5.6 Analog Scaling .....	4-48
4.6 Input Setting.....	4-51
4.6.1 Input Line Operation Selection.....	4-51
4.6.2 Laser Stop.....	4-57
4.6.3 Trigger Mode.....	4-58
4.6.4 Input Line Saving Setting .....	4-60
4.7 Alarm Setting .....	4-61
4.7.1 Alarm Delay Count .....	4-62
4.7.2 Alarm Analog Output.....	4-63
4.7.3 Alarm Digital Output.....	4-65
4.8 System Setting.....	4-68
4.8.1 Display Digit .....	4-68
4.8.2 ECO Mode .....	4-70
4.8.3 Display Inversion.....	4-71
4.8.4 Language Setting.....	4-72
4.8.5 Settings Initialization .....	4-73
4.9 1 point/2 points/3 points Teaching .....	4-75
4.9.1 1 point Teaching.....	4-76
4.9.2 2 points Teaching .....	4-79
4.9.3 3 points Teaching .....	4-82
4.10 Zero Setting .....	4-86
4.11 Measured Value Resetting .....	4-88
4.12 Key Lock.....	4-89
4.12.1 Key Lock Setting .....	4-89
4.12.2 Key Lock OFF .....	4-89
<b>5 Maintenance .....</b>	<b>5-1</b>
5.1 Maintenance and Inspection .....	5-2
5.1.1 Maintenance Precautions .....	5-2
5.1.2 Main Inspection Items .....	5-2
<b>6 Troubleshooting.....</b>	<b>6-1</b>
6.1 Solutions to Problems .....	6-2
6.2 Error Messages and Action Methods.....	6-4
<b>7 Specifications and Dimensions.....</b>	<b>7-1</b>
7.1 Specifications.....	7-2
7.1.1 Beam Diameter .....	7-5
7.1.2 Mutual Interference Area .....	7-6
7.2 Shapes and Dimensions .....	7-10

7.2.1 Product.....	7-10
7.2.2 Optional Cable .....	7-11
7.2.3 Optional Cable Installation Diagram .....	7-12

<b>Appendix Screen Transition List .....</b>	<b>App-1</b>
Screen Transition List .....	App-2

(MEMO)

# 1 Before Using This Product

---



1.1 Safety Precautions (Always observe) .....	1-2
1.2 Handling Precautions.....	1-3
1.2.1 Explanation of Graphic Symbols .....	1-3
1.2.2 Handling Precautions.....	1-3
1.3 Terminology.....	1-6
1.4 Regulations and Standards .....	1-7
1.5 Conditions for Compliance with CE Marking/UKCA Marking.....	1-8
1.6 Laser Safety Standards .....	1-9
1.6.1 IEC / EN / JIS / GB / KS.....	1-9
1.6.2 FDA.....	1-10
1.7 Contents of Package.....	1-11











## 1.1 Safety Precautions (Always observe)

### 1.1 Safety Precautions (Always observe)

This section explains important rules that must be observed to prevent personal injury and property damage.

- **Safety precautions items are classified into “WARNING” and “CAUTION” depending on the level of hazard.**





 <b>WARNING</b>	Risk of death or serious injury.
 <b>CAUTION</b>	Risk of minor injury or property damage.

 <b>WARNING</b>	
	• Do not use this product as a sensing device for personal protection. Using this product as a sensing device for personal protection may result in death or serious injury.
	• For sensing devices for personal protection, use products that conform to the laws and standards related to personal protection in each country, such as OSHA, ANSI, and IEC.
	• This product is intended to be used to detect target objects and is not provided with control functions that prevent accidents to ensure safety.
	• To prevent electric shock, ensure that the frame ground (F.G.) terminal of the product is grounded to a Class D ground (100 Ω or less) or higher.
	• Do not use this product in areas with inflammable gases. (Doing so may cause an explosion.)
	• Avoid observing beams continuously, particularly in a dark surrounding environment.
	• Do not stare into laser beam with an optical device such as telephoto optics.
	• Be careful not to directly stare into the laser beam emitting part or the laser beam reflected on a mirror surface.
	• Never attempt to disassemble, repair, or modify this product. This product is not equipped with function that automatically stops laser radiation when it is disassembled. Therefore, there is a risk that you may be exposed to laser radiation when the product is disassembled.
	• Do not use the product in a way that is not specified in this User's Manual. Controlling or adjusting the product according to procedures other than those specified in this User's Manual may lead to dangerous exposure to laser radiation.

## 1.2 Handling Precautions

### 1.2.1 Explanation of Graphic Symbols

- In this manual, the following symbols are used to indicate safety information that must be observed.

	Indicates an action that is prohibited or a matter that requires caution.
	Indicates an action that must be taken.
	Indicates details about the subject in question or information useful to remember.
	Indicates operation procedures.

### 1.2.2 Handling Precautions

#### Specifications

- This product has been developed and manufactured for industrial use only.
- Do not use this product outside the scope of the specifications. Doing so may result in accidents or failures.  
It will also significantly shorten the service life.
- Note that, if this product is used for many hours, the brightness of the display section drops over time due to aging.
- If there are objects with high reflectance around the detection point, the product may be affected by ambient leakage light.
- Specular reflection of light may prevent normal measurement if it enters the beam receiving part. Be careful when installing the product if the reflectance of the sensing objects is high.
- For high-precision sensing, perform an analog scaling and a span adjustment in the actual installation conditions.

#### Power Supply

- Verify that the supply voltage fluctuations are within the rating when using the product. Applying a voltage greater than the rated voltage or directly applying AC power will result in damage or burning.
- To ensure performance, use the product at least 30 minutes (warm-up time) after the power is turned ON.
- If power is supplied from a commercial switching regulator, ensure that the frame ground (F.G.) terminal of the power supply is connected to an actual ground.
- Make sure that the power supply input satisfies the following items.
  - The power supply unit must be certified for use in your region.
  - The output holding time of the power supply unit must be 20 ms or more.
  - The current capacity (recommended current capacity including starting current, external output current, and analog output current) of the power supply unit must be 500 mA or more, including a rated output voltage of 24 VDC  $\pm$ 10 % and a ripple of 0.5 V (P-P).
  - If CE marking is required, the Safety Extra Low Voltage (SELV) or Protective Extra Low Voltage (PELV) of the power supply unit must comply with the EMC Directive.

## 1.2 Handling Precautions

---

- If UKCA marking is required, the Safety Extra Low Voltage (SELV) or Protective Extra Low Voltage (PELV) of the power supply unit must comply with the EMC Regulations.
- When using this product in a positive ground environment, do not mix positive and negative grounds. In particular, on most PCs, the 0 V and F.G. terminals are internally connected. Connecting these terminals by mistake may cause a short circuit via the 0 V of the PC, causing device damage. Note that the F.G. of the product and the internal power supply and signal lines are isolated by capacitors.

### Wiring

- Before wiring work, always turn the power off.
- Do not wire in parallel with a high-voltage line or power line, or run through the same conduit. Doing so may result in malfunctioning due to induction.

### Operating Environment

- This product is suitable for indoor use only.
- Do not install the sensor in the following locations.
  - Locations subject to flammable gas, corrosive gas, or excessive dust
  - Locations subject to dust, metal particles, or saline matter
  - Location around which there are combustibles
  - Atmospheres containing benzene, paint thinner, alcohol, or other organic solvents or strong alkaline substances such as ammonia or caustic soda
  - Locations subject to severe vibration or shock
  - Locations subject to direct sunlight
  - Locations subject to water, oil, or chemicals
  - Locations where load is applied to the sensor
- Use the product in an environment where the temperature ranges between -10 °C and +45 °C. Also, store the product in an environment where the temperature ranges between -20 °C and +60 °C.

However, avoid using the product in an environment where icing may occur.

- Use and store the product in an environment where the humidity ranges between 35 % RH and 85 % RH. However, avoid using the product in an environment where dew condensation may occur due to a sudden temperature change.
- The service life of a semiconductor laser depends on the ambient operating temperature. When using the product near a heat generation part, lower the ambient temperature as much as possible by cooling, etc.
- Install this product on a surface with good heat dissipation as the product itself also generates heat. If used at an ambient temperature of 40 °C or more, the product should be installed on an aluminum or steel surface with a surface area of 200 cm<sup>2</sup> or more.
- Furthermore, when installing two or more of this product in parallel, provide a clearance of 20 mm or more between the products, and install each one on an aluminum or steel surface with an area of 200 cm<sup>2</sup> or more at the temperature of 40 °C or less.
- Performance may not be satisfactory in a strong electromagnetic field.
- Do not allow extraneous light such as sunlight or other light that has the same wavelength as the laser to directly hit the beam receiving part. In particular, if precision is required, use this product by mounting a douser or similar material.
- Keep the beam emitting and receiving parts of this product clean and free of water, oil, fingerprints, and other substances that refract light as well as dust, grit, and other objects that intercept light. When cleaning the surfaces, wipe them with a lint-free soft cloth or lens cleaning paper.



- Do not drop or subject this product to strong shocks. Doing so may result in an accident or failure.

### **Other Precautions**

- When this product becomes unnecessary, dispose of the product properly as industrial waste in accordance with the applicable law in the country.
- When exporting the product or when taking it out of Japan, the user is required to check applicable standards, laws and regulations.

## 1.3 Terminology

---

### 1.3 Terminology

Term	Description
Measurement display	A display that allows the user to check the measured distance (measured value) between the sensor and the sensing object
HIGH set value / LOW set value	A value (threshold) that is used to judge if a measure value falls within the predetermined range. The upper limit threshold is the "HIGH set value" and the lower limit threshold is the "LOW set value".
Teaching	A function for setting the HIGH set value / LOW set value using actual sensing objects.
Measured raw value	A measured value before moving average processing or zero setting.
Final measured value	A measured value after moving average processing or zero setting that was output after alarm processing or judgment processing.
Brightness tuning	If the brightness of sensing objects varies, set the brightness in advance and tune the adjustment range.
Setting resolution	The minimum unit of setting that this product supports. In switch operation, values can be manipulated only up to the unit of setting resolution of the model for each distance type.

### 1.4 Regulations and Standards

#### ■ Conforming directives and conforming regulations

EU Law: EMC Directive 2014/30/EU

British Legislation: EMC Regulations 2016/1091

- Applicable standards
  - EN 60825-1
  - EN 61000-6-2
  - EN 61000-6-4
- US Regulations: FDA21 CFR1040.10, and 1040.11 (Laser Notice No.56 applied)

#### ■ Conforming standards

- USA/Canada Standards
  - UL61010-1
  - CAN/CSA-C22.2 No.61010-1
- Other standards
  - IEC 60825-1
  - JIS C 6802
  - GB 7247.1
  - KS C IEC 60825-1
  - KN 61000-6-2
  - KN 61000-6-4

#### Note

- For the standards in US / Canada, cTÜVus mark by a Notified Body TÜV SÜD America has been acquired.



- When using this product, be sure to check and comply with the regulations and standards applicable in the country or region where the product is used.

## 1.5 Conditions for Compliance with CE Marking/UKCA Marking

---

### 1.5 Conditions for Compliance with CE Marking/UKCA Marking

To use this product as a CE marking/UKCA marking compliant product, the following conditions must be met.

- The signal and power lines connected to the product must not exceed the maximum length of the optional cable available.  
CN-8A-C5 (Analog output type) / Cable length 5 m
- If compliance with CE marking is required, SELV (Safety Extra Low Voltage) or PELV (Protective Extra Low Voltage) power supply units that comply with the EMC Directive must be used.
- If compliance with UKCA marking is required, SELV (Safety Extra Low Voltage) or PELV (Protective Extra Low Voltage) power supply units that comply with the EMC Regulations must be used.

## 1.6 Laser Safety Standards

### 1.6.1 IEC / EN / JIS / GB / KS

To prevent laser products from affecting their users, IEC, EN, JIS, GB, and KS standards have the following respective standards:

These standards classify laser products into classes according to the hazard level of laser, and prescribe safety and preventive measures that should be implemented for each class.

This product belongs to **Class 2 laser products** according to “Radiation safety standard of laser products” specified in IEC 60825-1:2014, EN 60825-1:2014/A11:2021, JIS C 6802:2014, GB 7247.1-2012, KS C IEC 60825-1:2014.

#### Explanation of hazard levels

Classification	Overview of danger evaluation
Class 2	A laser that emits visible light with the wavelength range of 400 nm to 700 nm under which eyes can be protected by an aversive reaction (avoidance behavior) such as a blink.

(Note 1) When an unexpected failure occurs, dangerous radiation may be generated. Therefore, pay special attention to safety.

#### Warning label

- Based on the safety standards for laser products, FDA/IEC (EN) standard certification / identification / warning labels are affixed to both sides of this product.
- This product is shipped with JIS, GB, and KS standard warning labels. Affix appropriate labels over the FDA/IEC (EN) labels as needed.

##### <FDA/IEC(EN)>



##### <JIS>



##### <GB>



##### <KS>



##### <Label position>

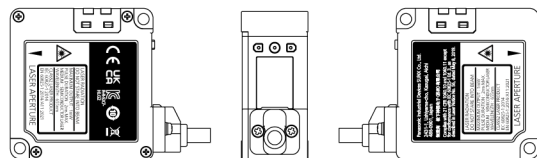

# 1.6 Laser Safety Standards

## 1.6.2 FDA

### ■ Exporting to the USA

If this product is incorporated into facilities or equipment to be exported to the US, it is subject to the laser regulations of the US Food and Drug Administration (FDA). To prevent laser products from affecting their users, PART1040 (Performance Standards for Light-Emitting Products) was established as one of the FDA regulations. These standards classify laser products into classes according to the hazard level of laser and prescribe safety and preventive measures that should be implemented for each class.

This product complies with the FDA regulations (FDA 21 CFR 1040.10 and 1040.11) in accordance with FDA Laser Notice No. 56, except for complying with IEC 60825-1:2014 Ed. 3. (**Class 2 laser products**)

### ■ Certificate / identification / warning label



<Label position>

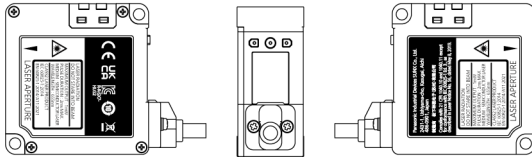

- To prevent the laser beam from directly entering your eyes, install this product so that the beam is above or below the eye level.

The safety distance (nominal ocular hazard distance: NOHD) is approximately 0.4 m. Be sure to terminate the laser beam with a diffuse reflector or absorber.

## 1.7 Contents of Package

The following accessories are included in the product package. Before using this product, make sure that no items are missing.

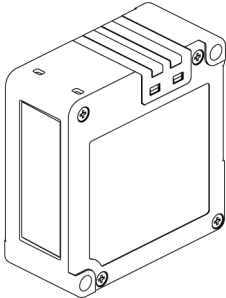
Products
<p><b>HL-G203B-A-MK</b> / 30 mm type <b>HL-G205B-A-MK</b> / 50 mm type <b>HL-G208B-A-MK</b> / 85 mm type <b>HL-G212B-A-MK</b> / 120 mm type <b>HL-G225B-A-MK</b> / 250 mm type</p> <ul style="list-style-type: none"><li>• Product</li></ul>  <ul style="list-style-type: none"><li>• Laser warning label: JIS, GB, and KS, 1 set each</li><li>• Installation instruction (English/Japanese, Chinese/Korean): 1 volume each</li><li>• General Information for Safety, Compliance, and Instructions: 1 volume</li></ul>

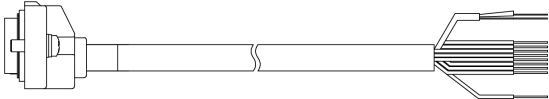
Optional cables (sold separately, for Analog Output Type)
<p><b>CN-8A-C2</b> / Cable length 2 m <b>CN-8A-C5</b> / Cable length 5 m</p> <ul style="list-style-type: none"><li>• Cable body</li></ul>  <p>Two M2.6 screws are attached.</p>

(MEMO)



# 2 System Configuration

---

2.1 System Configuration Diagram .....2-2

2.2 Description of Parts.....2-3

## 2.1 System Configuration Diagram

---

### 2.1 System Configuration Diagram

The following shows a system configuration and the optional cable used to connect devices.

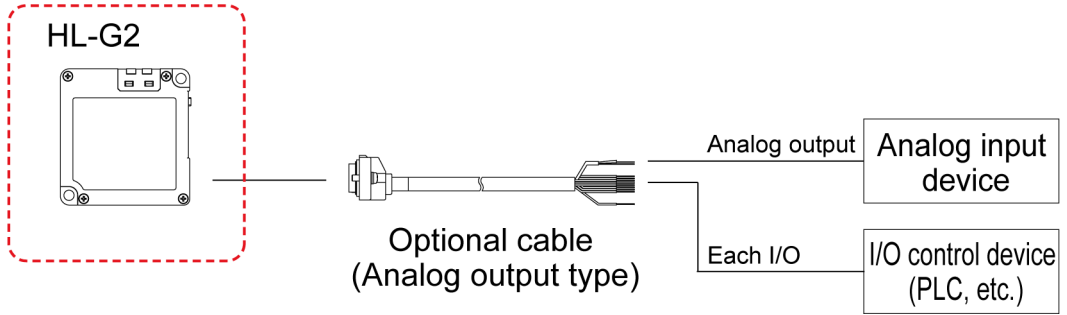

## 2.2 Description of Parts

### ■ Sensor unit

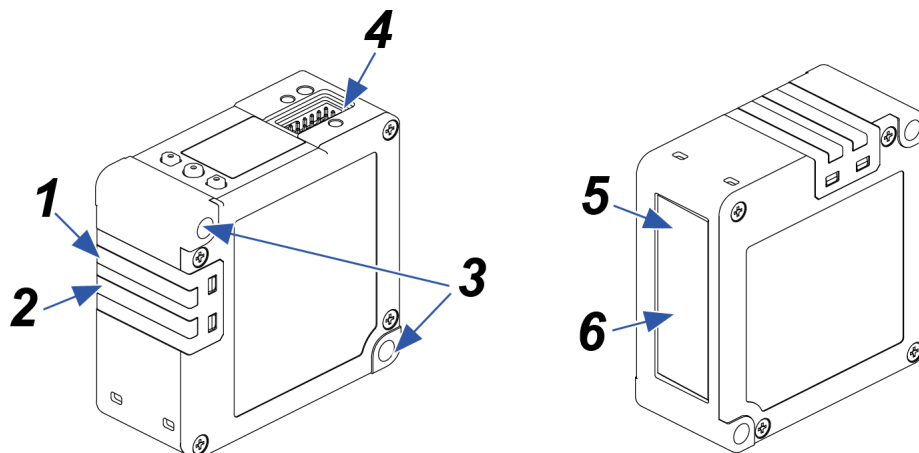

	Name	Function
1	Laser radiation indicator	Lit in green while laser beams are being emitted. It blinks if an error occurs.
2	Alarm indicator	Lit in orange when an measurement alarm occurs. It blinks if an error occurs.
3	Mounting hole	These hole are used to mount the sensor on machinery with M4 screws.
4	Cable connector part	Used when connecting the sensor with a optional cable.
5	Beam emitting part	This part emits laser beam.
6	Beam receiving part	This part receives the beam reflected on the measurement object.

## 2.2 Description of Parts

---

### ■ Operation/display section

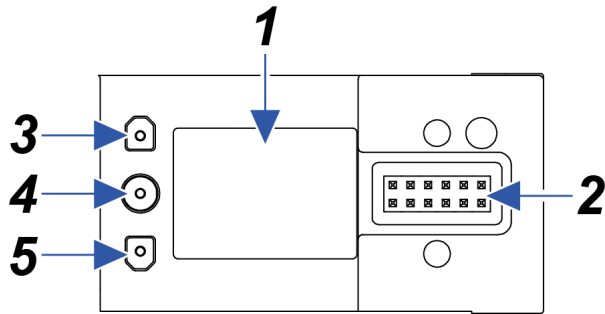

	Name	Function
1	Display section	Displays measured values, settings, and error codes <sup>(Note 1)</sup> .
2	Cable connector part	Used when connecting the sensor with a optional cable.
3	UP (DOWN) key	Used to change setting items and settings when configuring settings.
4	ENTER key	
5	DOWN (UP) key	

(Note 1) For error messages and actions to be taken, refer to "6.2 Error Messages and Action Methods".

### ■ Measurement display

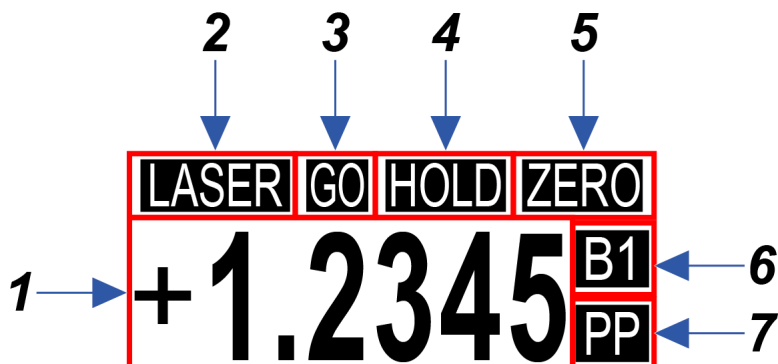

	Name	Function
1	Measurement value display	The current measured value (mm) is displayed with a sign.
2	LASER icon	Displayed when the laser is turned on.
3	HI / GO / LO icons	Displayed depending on the state of the measured value judgment result. When the measured value exceeds the HIGH set value, "HI" is displayed. When the measured value falls below the LOW set value, "LO" is displayed. When the measured value is within the range of the HIGH set value / LOW set value, "GO" is displayed.
4	HOLD icon	Displayed when the laser is on hold.
5	ZERO set icon	Displayed when zero set is turned ON.
6	Bank icons	The number of currently used bank (B1 to B4) is displayed.
7	Hold mode icons	The currently selected hold mode is displayed. <ul style="list-style-type: none"> <li>• Peak Hold: P</li> <li>• Bottom Hold: B</li> <li>• Peak-to-Peak Hold: PP</li> </ul> No icon is displayed when "None (Normal mode)" is set.

## 2.2 Description of Parts

### Note

- The display range of measured values for each distance type is as follows.

Model name	Measurement center distance	Measurement range <sup>(Note 1)</sup>	Display range <sup>(Note 2)</sup>
HL-G203B-A-MK	30 mm	±5 mm	-9.5000 to +9.5000
HL-G205B-A-MK	50 mm	±10 mm	-95.000 to +95.000
HL-G208B-A-MK	85 mm	±20 mm	-95.000 to +95.000
HL-G212B-A-MK	120 mm	±30 mm	-95.000 to +95.000
HL-G225B-A-MK	250 mm	±150 mm	-950.00 to +950.00

(Note 1) The measurable range from the measurement center distance. Use outside the measurement range is not recommended although the measured values will be output, since they are out of the specification range.

(Note 2) The range of values displayed on the display section.

- When the measured value is above the positive limit of the display range, "+OVER" is displayed on the display section.

A small rectangular display area with the text "+OVER" in the center. Above the text is a small icon of a laser beam, and to the right is a small icon of a battery.

- When the measured value is below the negative limit of the display range, "-OVER" is displayed on the display section.

A small rectangular display area with the text "-OVER" in the center. Above the text is a small icon of a laser beam, and to the right is a small icon of a battery.

- When the measured value is indeterminate, "----" is displayed on the display section.

A small rectangular display area with four dashes "----" in the center. Above the dashes is a small icon of a laser beam, and to the right is a small icon of a battery.

- In an alarm state, "ALARM" is displayed on the display section. (Only when the Alarm digital output setting is "Alarm")

A small rectangular display area with the text "ALARM" in the center. Above the text is a small icon of a laser beam, and to the right is a small icon of a battery.

- If an error occurs during setting or measurement, the corresponding error code will be displayed on the display section.

For error messages and actions to be taken, refer to "6.2 Error Messages and Action Methods".

A small rectangular display area with the error code "13001" in the center. Above the code is a small icon of a laser beam, and to the right is a small icon of a battery.

### ■ Setting screen (Setting mode)

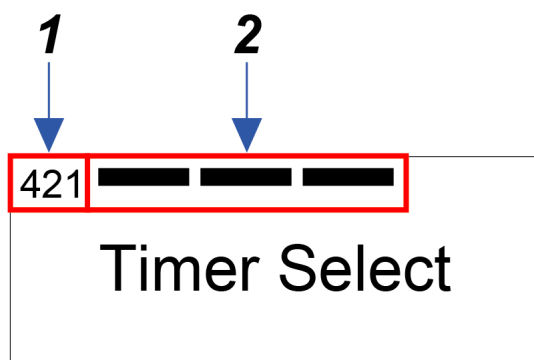

	Name	Function
1	Menu number	Shows the setting item by number. Hold down the <ENTER> key for 2 seconds on the measurement display. The screen that appears after entering the Setting mode is the first level. Following this, pressing the <ENTER> key each time brings you to the second level, the third level, and so on. When the menu number is "421", the first level is 4, the second level is 2, and the third level is 1.
2	Hierarchical level display bar	Shows the hierarchal level of the setting item as bars. When three bars are displayed, the setting item is at the third level.

### ■ Setting items corresponding to menu numbers

Menu number	Hierarchical level display bar (Number of bars)	Setting item	Reference page
1	1	Bank	"4.2 Bank Switching"
2	1	Sensing	"4.3 Sensing Setting"
3	1	Judgment	"4.4 Judgment Setting"
4	1	Output	"4.5 Output Setting"
5	1	Input	"4.6 Input Setting"
6	1	Alarm	"4.7 Alarm Setting"
9	1	System	"4.8 System Setting"
21	2	Sampling Frequency	"4.3.1 Sampling Frequency"
22	2	Average Times	"4.3.2 Average Times"
23	2	Brightness Tuning	"4.3.3 Brightness Tuning"
24	2	Hold Mode	"4.3.4 Hold Mode"
25	2	±Inversion	"4.3.5 Inversion of Measured Value"
26	2	Span	"4.3.6 Span"
27	2	Offset	"4.3.7 Offset"

## 2.2 Description of Parts

---

Menu number	Hierarchical level display bar (Number of bars)	Setting item	Reference page
31	2	HIGH Set Value	"4.4.1 HIGH Set Value"
32	2	LOW Set Value	"4.4.2 LOW Set Value"
33	2	Hysteresis	"4.4.3 Hysteresis"
34	2	Teaching Mode	"4.4.4 Teaching Mode"
35	2	Tolerance	"4.4.5 Tolerance"
41	2	Judgement Output	"4.5.1 Judgment Output"
42	2	Output Delay Timer	—
43	2	Output Type	"4.5.4 Output Type"
44	2	Analog Output	"4.5.5 Analog Output"
45	2	Analog Scaling	"4.5.6 Analog Scaling"
51	2	Input Select	"4.6.1 Input Line Operation Selection"
52	2	Laser Stop	"4.6.2 Laser Stop"
53	2	Trigger Mode	"4.6.3 Trigger Mode"
54	2	Save Config(via Input)	"4.6.4 Input Line Saving Setting"
61	2	Alarm Analog Output	"4.7.2 Alarm Analog Output"
62	2	Alarm Digital Output	"4.7.3 Alarm Digital Output"
63	2	Alarm Delay Count	"4.7.1 Alarm Delay Count"
91	2	Display Digit	"4.8.1 Display Digit"
92	2	ECO Mode	"4.8.2 ECO Mode"
93	2	Display Inversion	"4.8.3 Display Inversion"
94	2	Language	"4.8.4 Language Setting"
96	2	Initialize	"4.8.5 Settings Initialization"
421	3	Timer Select	"4.5.2 Output Delay Timer Selection"
422	3	Timer Setting	"4.5.3 Output Delay Timer Setting"



# 3 Installation and Setup

---

3.1 Flow of Operations up to Measurement Startup .....	3-2
3.2 Sensor Installation .....	3-3
3.3 Sensor Installation Direction and Angle .....	3-4
3.4 Optional Cable Connection Method .....	3-7
3.5 Functions and Wiring of I/O Lines.....	3-9
3.5.1 Grounding .....	3-12
3.5.2 Precautions for positive ground environment.....	3-13
3.6 Initial Startup Settings .....	3-14

## 3.1 Flow of Operations up to Measurement Startup

---

### 3.1 Flow of Operations up to Measurement Startup

This section explains the flow of operations up to measurement startup by using workpiece detection mode as an example.

#### 1. Before power ON

Check package contents and confirm that all parts are complete.



#### 2. Installation and wiring

Install this product and connect the optional cables according to the installation and wiring methods.

1. "3.2 Sensor Installation"
2. "3.3 Sensor Installation Direction and Angle"
3. "3.4 Optional Cable Connection Method"



#### 3. Initial setup

Turn the power ON and perform the initial setup.

1. "3.6 Initial Startup Settings"



#### 4. Setting up the functions

Perform the necessary function settings according to your environment.

- "4.1 List of Functions"

## 3.2 Sensor Installation

### 1 2 Procedure

1. When installing this product, use M4 captive washer screws (to be prepared separately).  
(Tightening torque: 0.8 N·m or less)

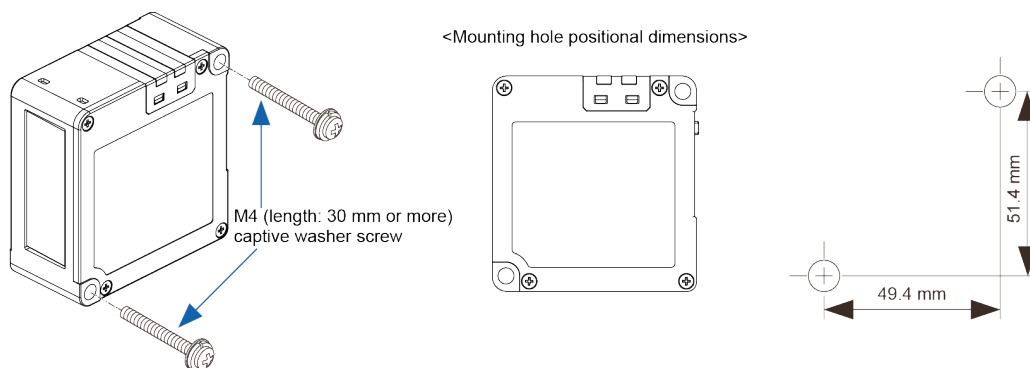

- Carefully handle the sensor so that no force is applied around the connector of the optional cable. Do not bend the cable close to the connector. Doing so may cause disconnection.
- Do not bend the optional cable to a radius of 50 mm or less.



- To prevent the sensor from falling due to screw loosening, take preventive measures such as using captive washer screws depending on the usage environment.
- Install the sensor so that the beam emitting part and beam receiving part surfaces are set in parallel with the measurement object.

### 3.3 Sensor Installation Direction and Angle

#### 3.3 Sensor Installation Direction and Angle

To stabilize measurement (including the reduction of measurement errors), install the sensor considering the installation direction depending on the operating environment.

Install the sensor so that the beam emitting part and beam receiving part surfaces are set in parallel with the measurement object.

##### ■ Installation Direction

- When the material or color of the measurement object largely varies  
To measure moving objects with significant differences in material or color, installing the sensor as shown in the figure below minimizes the measurement error.

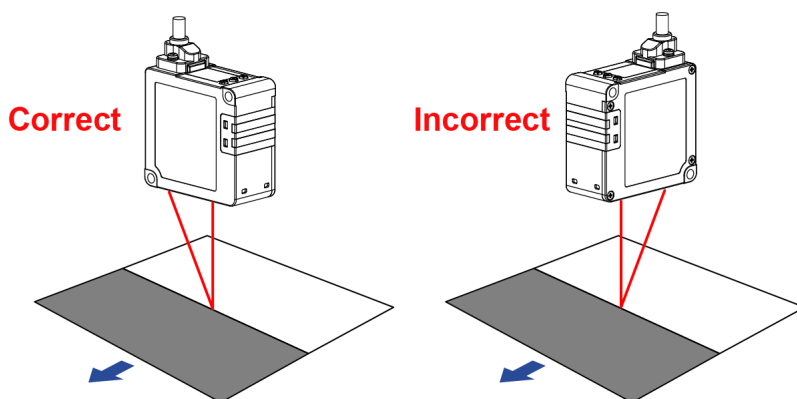

- When installing the sensor head on a wall surface  
To prevent entry of multiple reflections from the wall surface into the beam receiving part, install the sensor as shown in the figure below. If the wall surface is highly reflective, it is effective to make it matte black.

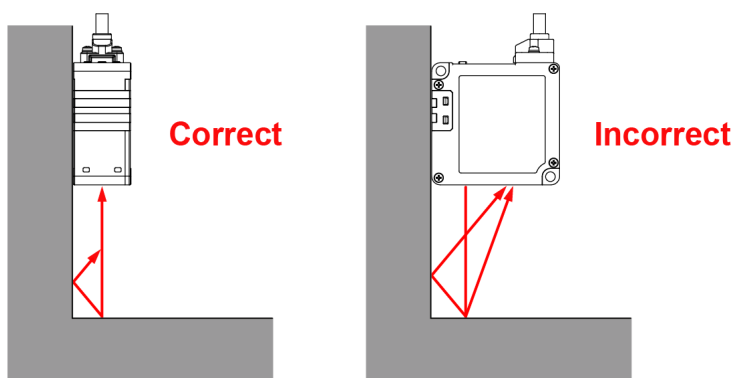

### 3.3 Sensor Installation Direction and Angle

- When the measurement object rotates

To measure rotating objects, installing the sensor as shown in the figure below minimizes the effects of vertical vibration, misalignment, etc.

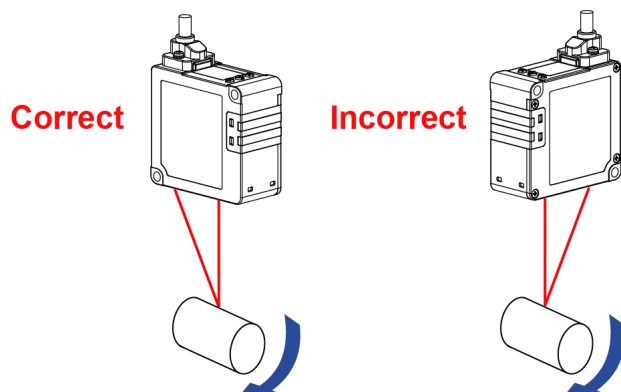

- When there are level differences on the surface of the measurement object

To measure moving objects with level differences on the surface, installing the sensor as shown in the figure below minimizes the effect of the level edges.

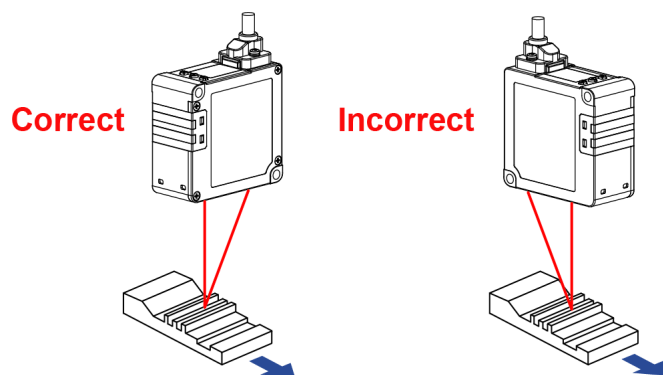

- When measuring a concave part

To measure objects in a narrow space or hole, install the sensor so that the light path from the beam emitting part to the beam receiving part is not blocked.

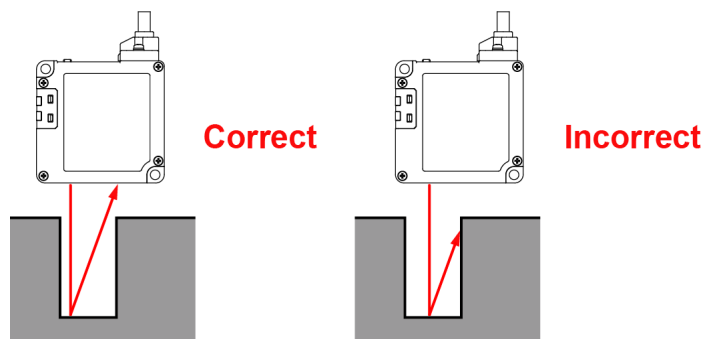

### 3.3 Sensor Installation Direction and Angle

---

#### ■ Installation Angle

Install the sensor so that the beam emitting part and beam receiving part surfaces are set at 90 degrees (parallel) with the measurement object.

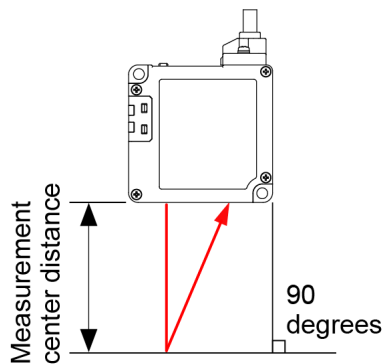

#### <Reference>

Model name	Measurement center distance	Measurement range
HL-G203B-A-MK	30 mm	±5 mm
HL-G205B-A-MK	50 mm	±10 mm
HL-G208B-A-MK	85 mm	±20 mm
HL-G212B-A-MK	120 mm	±30 mm
HL-G225B-A-MK	250 mm	±150 mm

## 3.4 Optional Cable Connection Method



- When using the optional cable, confirm that there is no foreign matters in the connector part before using the cable.
- Always grasp the connector body when connecting or disconnecting the connector. Wires may break if excessive stress is applied to the cable.
- Insert the connector all the way in and tighten the M2.6 screws to this product before using it. If the connectors are not completely connected, the sensor unit may become damaged.



- Do not insert the connector at an angle. Otherwise, connector pins may be bent.

### 1 2 Procedure

1. Insert the sensor unit connection connector on the optional cable into the sensor unit cable connector.

When doing this, insert the protrusions on the sensor unit connector on the communication cable into the holes on the connector for the sensor unit connection cable.

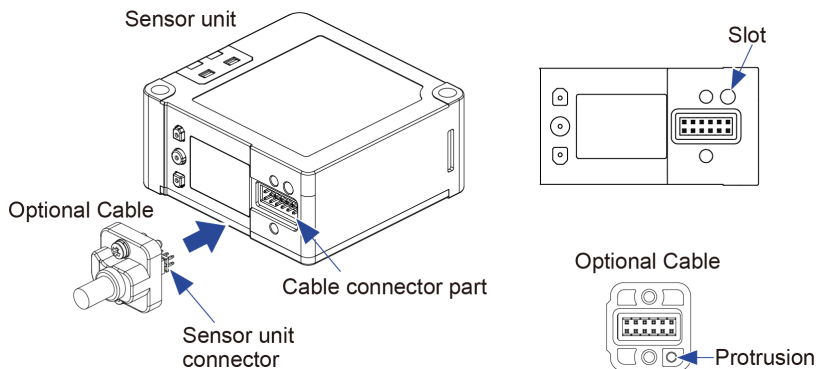

2. Tighten the two M2.6 screw. Tighten the two M2.6 screw. (Tightening torque 0.23 to 0.3 N·m)

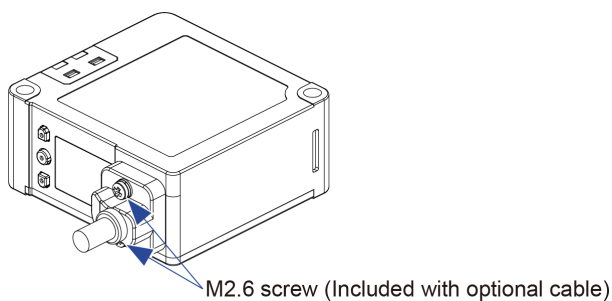

3. When removing the connecting cable from the sensor, loosen the two M2.6 screws, hold the connector part of the cable, and pull out the cable.

### 3.4 Optional Cable Connection Method

---

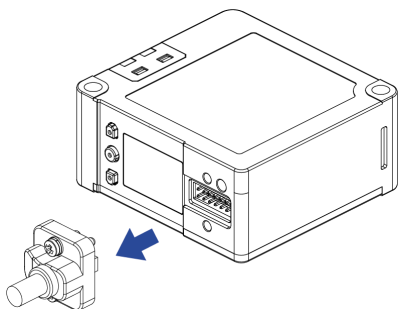



## 3.5 Functions and Wiring of I/O Lines



- Before wiring, always turn the power OFF.
- Be sure to use the specified optional cables.
- Be sure to insulate the ends of leads that are not used.

### ■ CN-8A-C□ (Analog output type)

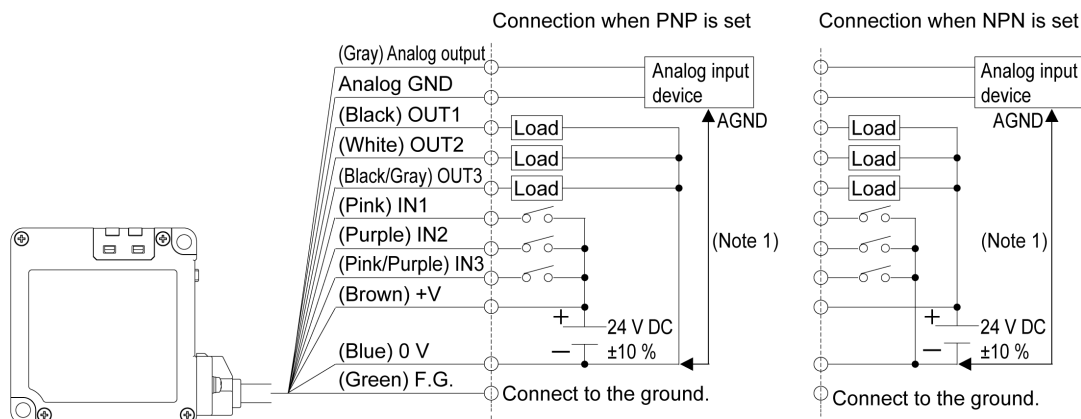

(Note 1) The sensor unit power supply (0 V) and analog GND terminals of this product are internally connected. When connecting the sensor to a non-insulated analog input device, make sure that no potential difference is created between the sensor unit power supply (0 V) and the GND of the analog input device power supply.

Failure to do so may cause failure or malfunction of the connected device or this product.

### 3.5 Functions and Wiring of I/O Lines

#### ■ I/O circuit diagram

When PNP is set

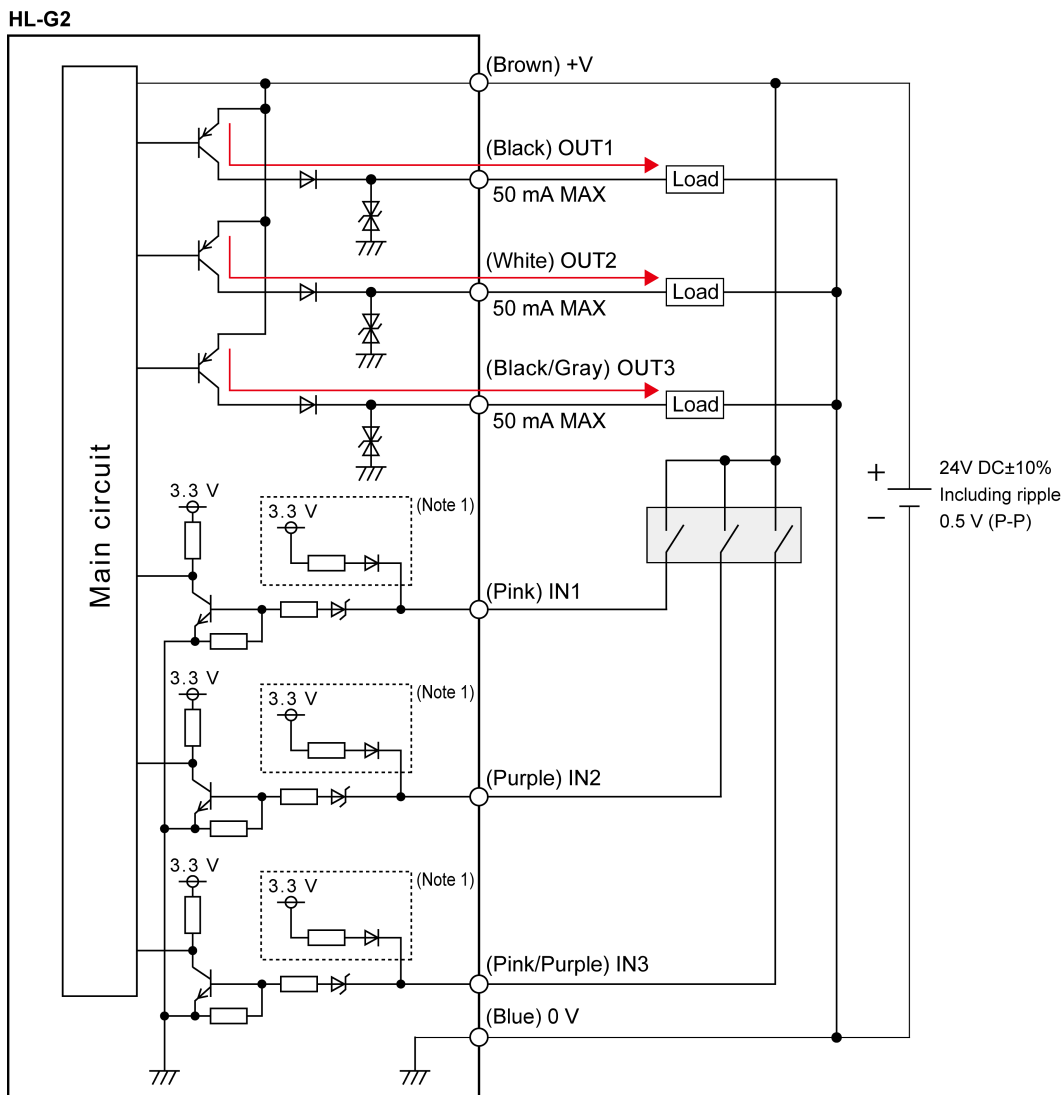

(Note 1) This product operates as a normal PNP input sensor according to the PNP input specifications. However, due to the effect of the NPN/PNP switching circuit, 3.3 V is applied from the input to the outside when PNP is set. Therefore, if the input is shorted to 0 V in the PNP setting, a current of approximately 1 mA will flow to the outside. Although this does not cause the product to fail, note that it allows a current to flow to the connected device.

When NPN is set

HL-G2

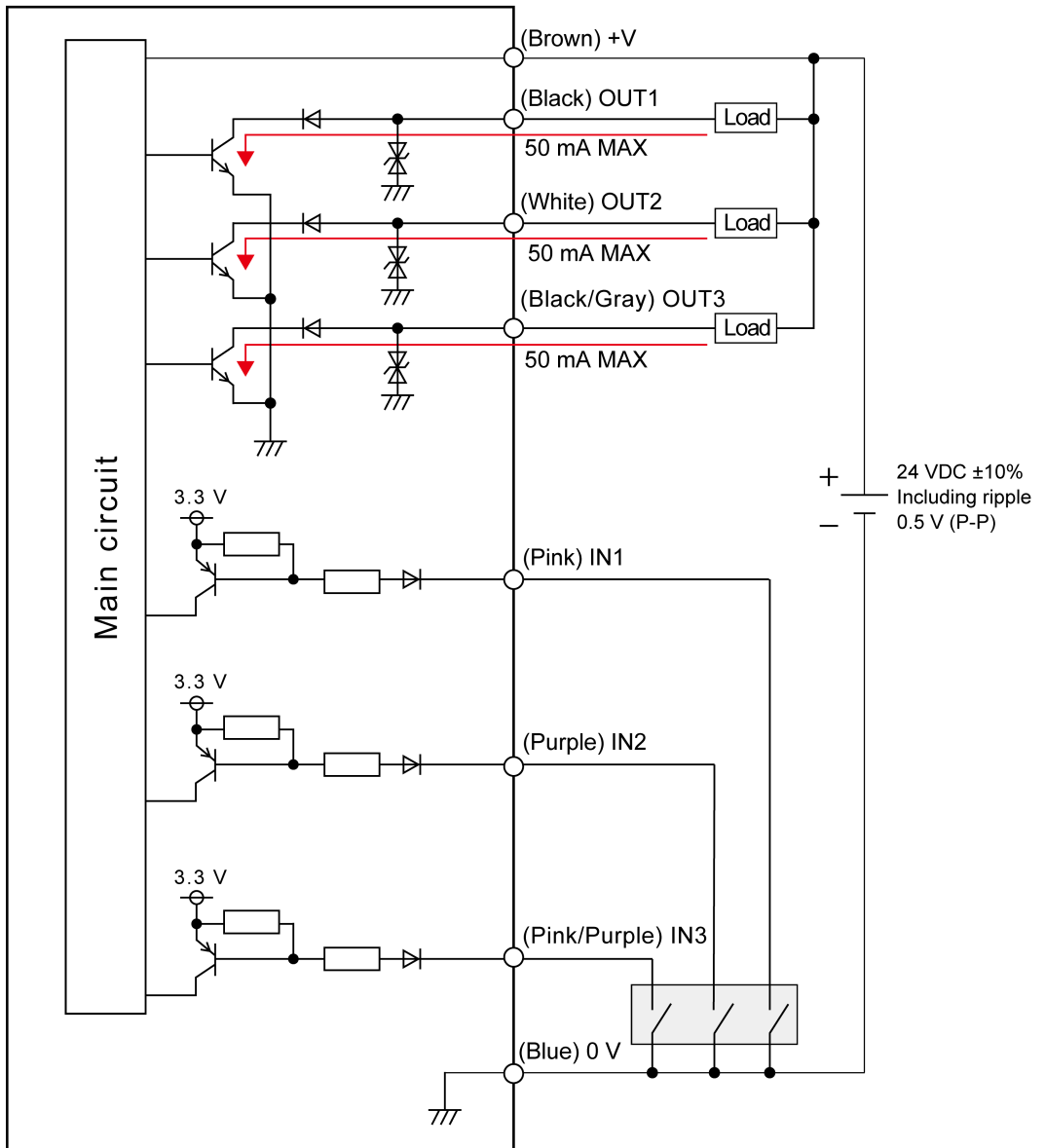

## 3.5 Functions and Wiring of I/O Lines

### Analog output circuit

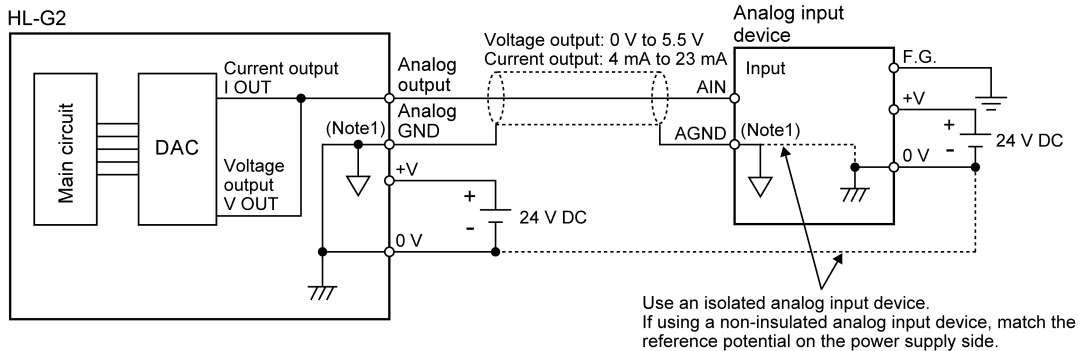

(Note 1) The 0 V and analog GND terminals of this product are internally connected. If there is a potential difference between the sensor unit power supply (0 V) and the GND of the analog input device power supply, an overcurrent may flow between the 0 V and the AGND, causing a failure. To avoid this, use an insulated analog input device or match the potential of the sensor unit power supply (0 V) with that of the GND of the analog input device power supply.

Note also that, if signals with a potential difference are incorrectly wired between the 0 V and the analog GND, an overcurrent may flow, causing a failure.

### 3.5.1 Grounding

- The power supply (+V, 0 V) and F.G. terminals of this product are isolated by capacitors.
  - The F.G. terminal and metal housing of this product are internally connected.
- To prevent electric shock and malfunction due to noise, use dedicated grounding with a resistance of 100  $\Omega$  or less (Class D or higher) and avoid common grounding with other devices.
- The point of grounding should be as close to this product as possible. The ground wire should be as short as possible.

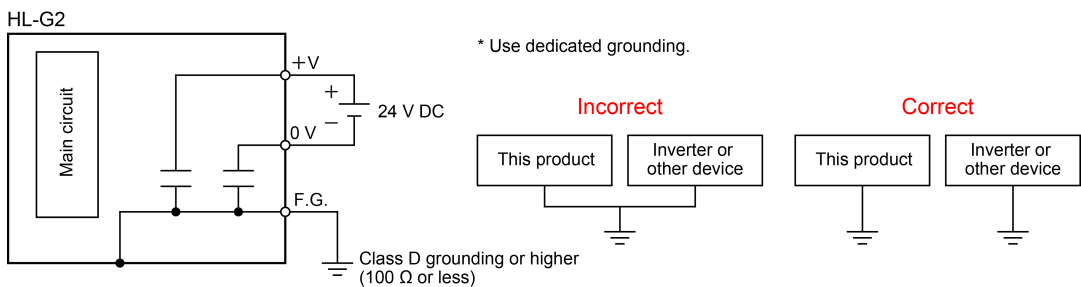

### 3.5.2 Precautions for positive ground environment

The 0 V and analog GND terminals of this product are internally connected.

Connecting the product to a PC or other device in which the F.G. and GND are internally connected may cause a short circuit in the power supply (24 VDC) through the PC or analog GND, resulting in a failure.

Note the following wiring precautions when using the product in a positive ground environment.

- Do not ground the F.G. of a PC or other device in which the F.G. and GND terminals are internally connected.

The internal connection state varies depending on the device. For details, refer to the instruction manual of the device that you use.

- Do not ground the +V terminal of this product.
- To connect the power supply (24 VDC) for the connected device to the positive ground, prepare a separate power supply (24 VDC) for this product and insulate this product.

Also, connect the I/O lines and analog output lines (including the analog GND) to the connected device with insulated I/O.

## 3.6 Initial Startup Settings

### 3.6 Initial Startup Settings

#### ■ Overview

After turning on the power supply for the first time or executing "Set value initialization", perform the language, NPN/PNP, and analog output settings.

#### 1 2 Procedure

1. When the power supply is turned on, the startup screen is displayed for two seconds and then the language setting screen is displayed.
2. Press the <UP> or <DOWN> key to select Japanese, English, or Chinese and then press the <ENTER> key.
3. The NPN/PNP setting screen is displayed. Select either NPN or PNP and press the <ENTER> key.
4. The Analog Output Select screen is displayed. Select either OFF, current, or voltage and press the <ENTER> key.
5. When the analog output setting is complete, the display changes to the measurement display.

#### Setting method

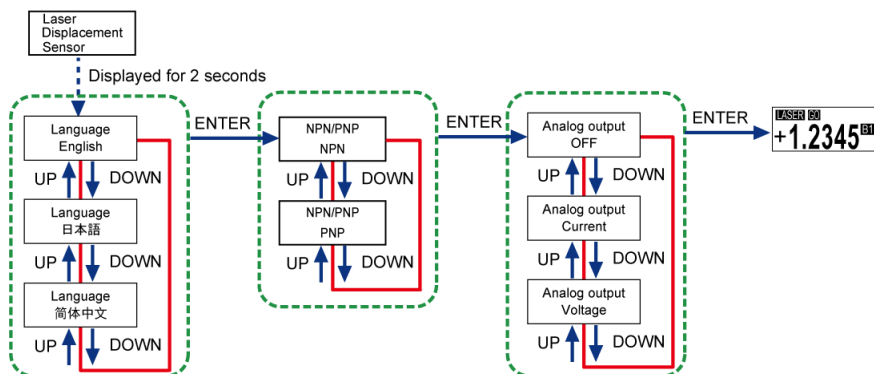

# 4 Description of Functions

---

4.1 List of Functions.....	4-3
4.2 Bank Switching .....	4-6
4.3 Sensing Setting.....	4-8
4.3.1 Sampling Frequency .....	4-8
4.3.2 Average Times .....	4-10
4.3.3 Brightness Tuning .....	4-12
4.3.4 Hold Mode.....	4-15
4.3.5 Inversion of Measured Value.....	4-19
4.3.6 Span.....	4-21
4.3.7 Offset.....	4-23
4.4 Judgment Setting .....	4-25
4.4.1 HIGH Set Value.....	4-25
4.4.2 LOW Set Value.....	4-29
4.4.3 Hysteresis .....	4-33
4.4.4 Teaching Mode.....	4-35
4.4.5 Tolerance .....	4-37
4.5 Output Setting .....	4-39
4.5.1 Judgment Output .....	4-39
4.5.2 Output Delay Timer Selection .....	4-41
4.5.3 Output Delay Timer Setting.....	4-45
4.5.4 Output Type .....	4-46
4.5.5 Analog Output .....	4-47
4.5.6 Analog Scaling .....	4-48
4.6 Input Setting.....	4-51
4.6.1 Input Line Operation Selection.....	4-51
4.6.2 Laser Stop.....	4-57
4.6.3 Trigger Mode.....	4-58
4.6.4 Input Line Saving Setting .....	4-60
4.7 Alarm Setting .....	4-61
4.7.1 Alarm Delay Count.....	4-62
4.7.2 Alarm Analog Output.....	4-63
4.7.3 Alarm Digital Output.....	4-65
4.8 System Setting.....	4-68
4.8.1 Display Digit .....	4-68
4.8.2 ECO Mode .....	4-70
4.8.3 Display Inversion.....	4-71
4.8.4 Language Setting .....	4-72
4.8.5 Settings Initialization .....	4-73

## 4 Description of Functions

---

4.9 1 point/2 points/3 points Teaching .....	4-75
4.9.1 1 point Teaching .....	4-76
4.9.2 2 points Teaching .....	4-79
4.9.3 3 points Teaching .....	4-82
4.10 Zero Setting .....	4-86
4.11 Measured Value Resetting .....	4-88
4.12 Key Lock .....	4-89
4.12.1 Key Lock Setting .....	4-89
4.12.2 Key Lock OFF .....	4-89



## 4.1 List of Functions

The items that can be set on the measurement display (RUN mode) are as follows.

### ■ Received light intensity monitor

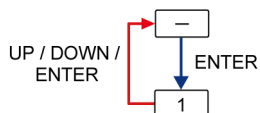

No.	Setting item	Display section	Description of function	Reference page
-	Measurement display		-	-
1	Received light intensity monitor		The peak intensity of received light (range: 0 to 1023) of the received light waveform. When the measured value is indeterminate, ---- is displayed.	-

### ■ HIGH set value setting / LOW set value setting

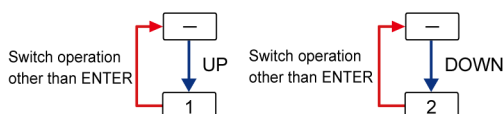

No.	Setting item	Display section	Description of function	Reference page
-	Measurement display		-	-
1	HIGH set value setting		Used to make fine adjustment of the HIGH set value.	"4.4.1 HIGH Set Value"
2	LOW set value setting		Used to make fine adjustment of the LOW set value.	"4.4.2 LOW Set Value"

### ■ 1-point / 2-point / 3-point teaching

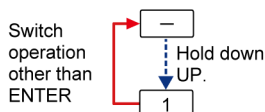

No.	Setting item	Display section	Description of function	Reference page
-	Measurement display		-	-
1	1 point / 2 points / 3 points teaching		Perform teaching using the method set in <b>Teaching type</b> under <b>Judgment setting</b> .	1 point/2 points/3 points Teaching

## 4.1 List of Functions

### ■ Zero setting ON / Zero setting OFF

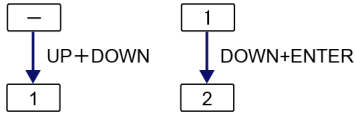

No.	Setting item	Display section	Description of function	Reference page
-	Measurement display		-	-
1	Zero setting ON		This function is used to forcibly set the measured value to "0". You can use the function to adjust the reference point when this product has been replaced or when the workpiece has been changed.	"4.10 Zero Setting"
2	Zero setting OFF		Used to clear the zero setting.	"4.10 Zero Setting"

### ■ Measured value resetting

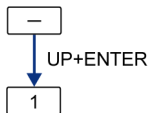

No.	Setting item	Display section	Description of function	Reference page
1	Measurement display		-	-
2	Reset		Used to reset the moving average data of the measured value or the value held by the hold function.	"4.11 Measured Value Resetting"

### ■ Key lock

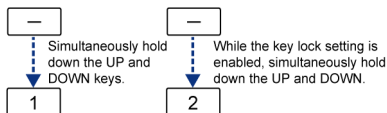

No.	Setting item	Display section	Description of function	Reference page
-	Measurement display		-	-
1	Key lock		Used to disable key operations.	"4.12.1 Key Lock Setting"
2	Key lock OFF		Used to release the key lock setting.	"4.12.2 Key Lock OFF"

■ Setting mode

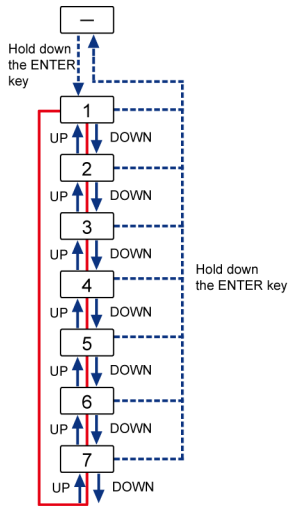

No.	Setting item	Display section	Description of function	Reference page
-	Measurement display		-	-
1	Bank switching		Used to switch over the bank to be used.	"4.2 Bank Switching"
2	Sensing setting		This is a function setting that is used to control the received light intensity of the sensor and to measure stably with accuracy.	"4.3 Sensing Setting"
3	Judgment setting		This is a function setting related to judgment results of the measured value.	"4.4 Judgment Setting"
4	Output setting		This is a function setting related to output operation.	"4.5 Output Setting"
5	Input setting		This is a function setting related to input operation.	"4.6 Input Setting"
6	Alarm setting		This is a function setting related to output when an alarm occurs.	"4.7 Alarm Setting"
7	System setting		This includes system settings such as language setting and initialization.	"4.8 System Setting"

## 4.2 Bank Switching

### 4.2 Bank Switching

#### ■ Overview

This product has four banks, Bank 1 to Bank 4, in order to hold some setting values.

By switching the bank to use, you can easily apply the settings when needed depending on the measurement object.

For details on the set values to be held in the banks, refer to "[Types of setting items read from banks](#)".

#### ■ Setting method

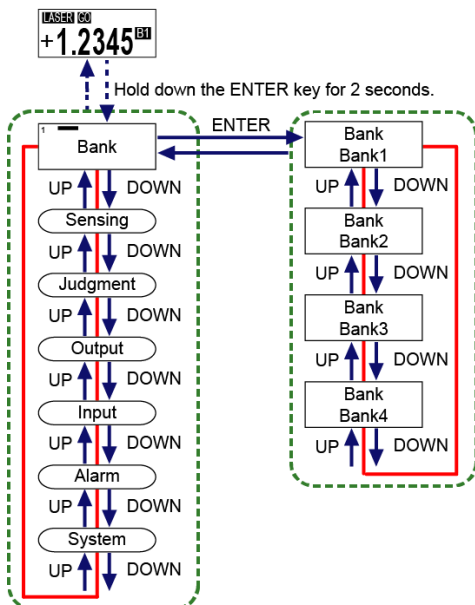

The set values held in the specified bank will be applied.

Whenever you change the settings thereafter, the new set values will be held in the bank.

#### **Note**

- The number of currently used bank is displayed on the measurement display.



- Hold down the <ENTER> key for 2 seconds on the setting screen, and the setting change is suspended and the screen returns to the previous display.

Setting item	Set value	Default value
Bank	Bank 1	Bank 1
	Bank 2	
	Bank 3	
	Bank 4	

#### ■ Types of setting items read from banks

Major setting item	Setting item
Sensing setting	Sampling frequency
	Average times
	Brightness tuning
	Hold mode
	Span
	Offset
Judgment setting	HIGH set value / LOW set value
	Hysteresis
	Teaching mode
	Tolerance
Output setting	Judgment output
	Output delay timer selection
	Output delay timer setting
	Analog scaling
	Analog scaling measured value A/B
	Analog scaling voltage A/B
Input setting	Trigger mode
	Alarm setting
Alarm setting	Alarm analog output
	Alarm digital output
	Alarm delay count
System setting	Display Digit
Others	Zero set setting
	Zero set correction value

## 4.3 Sensing Setting

### 4.3 Sensing Setting

#### ■ Overview

This is a function setting that is used to control the received light intensity of this product and perform calculations on the output measurement values to ensure accurate and stable measurement.

#### 4.3.1 Sampling Frequency

#### ■ Overview

You can change the sampling frequency according to the moving speed of the object.

#### ■ Setting method

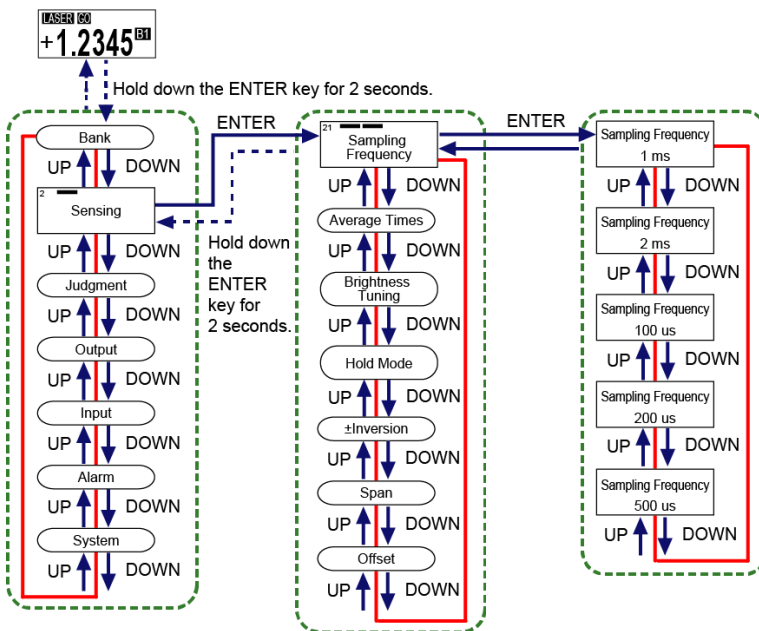

#### Note

- When measuring an object with extremely small intensity of received light such as black rubber, lengthen the sampling frequency to receive sufficient light intensity so as to achieve stable measurement.
- Depending on measurement objects, the measurement range may become narrow.
- The displayed unit “ms” stands for milliseconds, and “us” stands for microseconds.
- Hold down the <ENTER> key for 2 seconds on the setting screen, and the setting change is suspended and the screen returns to the previous display.

Setting item	Set value	Default value
Sampling Frequency	100 $\mu$ s	1 ms
	200 $\mu$ s	
	500 $\mu$ s	
	1 ms	
	2 ms	

## 4.3 Sensing Setting

### 4.3.2 Average Times

#### ■ Overview

Set the number of moving averages used to calculate measured values. This setting is used to stabilize fluctuating measured values.

#### When the average count is set to 4

(Sampling cycle: 1 ms)

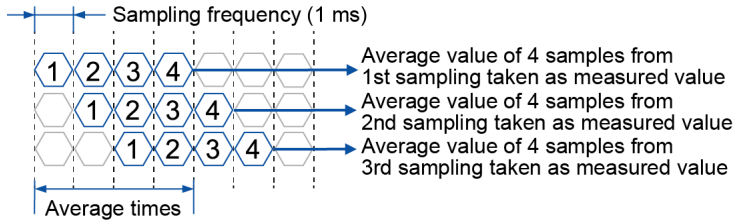

#### ■ Setting method

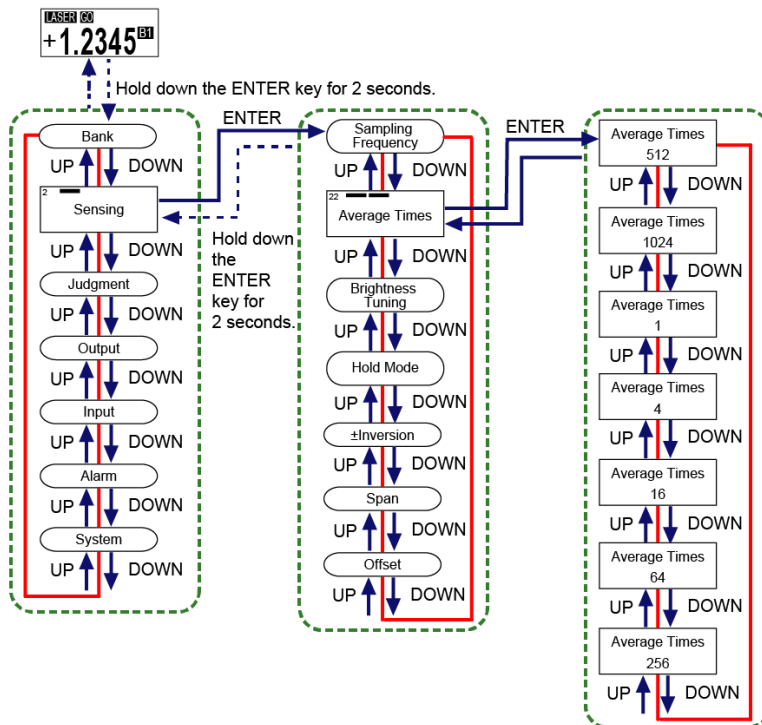



**Note**

- Setting the average count to a small value enables the sensor to respond to momentary changes. Setting the average count to a large value enables the sensor to suppress the effect of momentary changes.
- When the average count is changed, the measured value is set to an indeterminate state until values are accumulated to reach the average count again.
- Hold down the <ENTER> key for 2 seconds on the setting screen, and the setting change is suspended and the screen returns to the previous display.

Setting item	Set value	Default value
Average Times	1	512
	4	
	16	
	64	
	256	
	512	
	1024	

## 4.3 Sensing Setting

### 4.3.3 Brightness Tuning

#### ■ Overview

Depending on the workpiece to be measured, you can change the beam brightness adjustment method.

When measuring two workpieces with large brightness difference, use the brightness tuning which may stabilize the measurement accuracy.

To select the brightness tuning, sensing objects with different brightness are required.

Adjustment method	Operation
Auto mode	The laser beam brightness is automatically adjusted. (Set value: OFF)
Brightness tuning	If the brightness of sensing objects varies, set the brightness in advance and tune the adjustment range. This allows a faster adjustment than the auto mode. (Set value: ON)

#### ■ Setting method

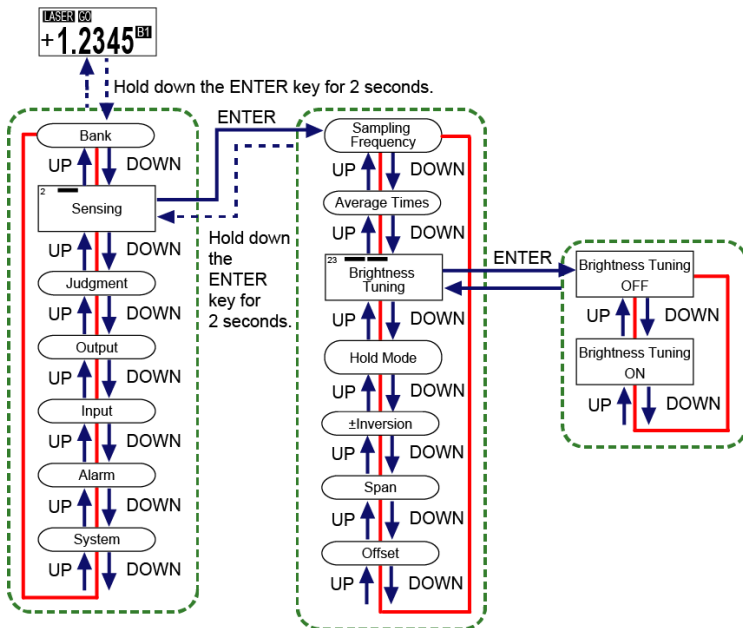

#### 📌 Note

- If the sampling cycle is changed after execution of brightness tuning, tuning must be made again.
- Hold down the <ENTER> key for 2 seconds on the setting screen, and the setting change is suspended and the screen returns to the previous display.

Setting item	Set value	Default value
Brightness tuning	OFF	OFF
	ON	

## ■ Brightness Tuning Procedure

When selecting Brightness tuning, both the bright portion and dark portion of the sensing object need to be registered in this product in advance.

Follow the procedure below to configure the settings.

### 1 2 Procedure

1. Prepare two workpieces with different brightness and turn ON "Brightness tuning".
2. Confirm that a message saying "Set 1st Target - Push ENTER SW" is displayed on the display section and then place the 1st workpiece and press the <ENTER> key.  
When the <ENTER> key is pressed, "Adjusting" is displayed on the display section.

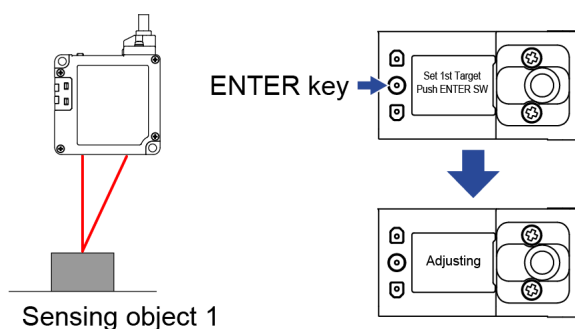

3. Confirm that a message saying "Set 2nd Target and Push ENTER SW" is displayed on the display section and then place the 2nd workpiece and press the <ENTER> key.  
When the <ENTER> key is pressed, "Adjusting" is displayed on the display section.

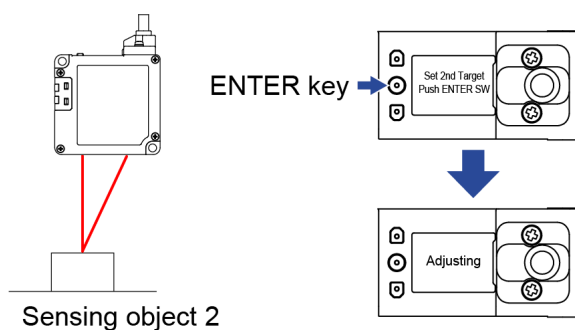

4. When the Brightness Tuning has succeeded, "Success" is displayed on the display section.

When the brightness tuning is successful

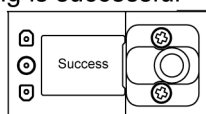

5. When the Brightness Tuning has failed, "Failed" is displayed on the display section.  
Perform brightness adjustment using two workpieces again.

## 4.3 Sensing Setting

---

When brightness  
tuning fails

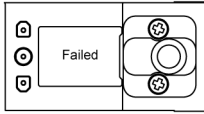

### Note

- In the following cases, Brightness Tuning will fail.
  - Alarm state
  - Indeterminate state
  - Hold state (In this case, the state changes to indeterminate state after execution of tuning.)
  - When optimal intensity of received light could not be obtained stably for a certain period of time
- Measuring another workpiece with significantly different reflectance from either of the two registered workpieces may cause an alarm due to saturation or lack of the received light intensity, or incorrect measurement due to a malfunction of the brightness adjustment.  
To measure three or more workpieces with different reflectance, use Auto mode.

### 4.3.4 Hold Mode

#### ■ Overview

Set a method to hold the measured value according to the measuring method of sensing objects.

#### ■ Setting method

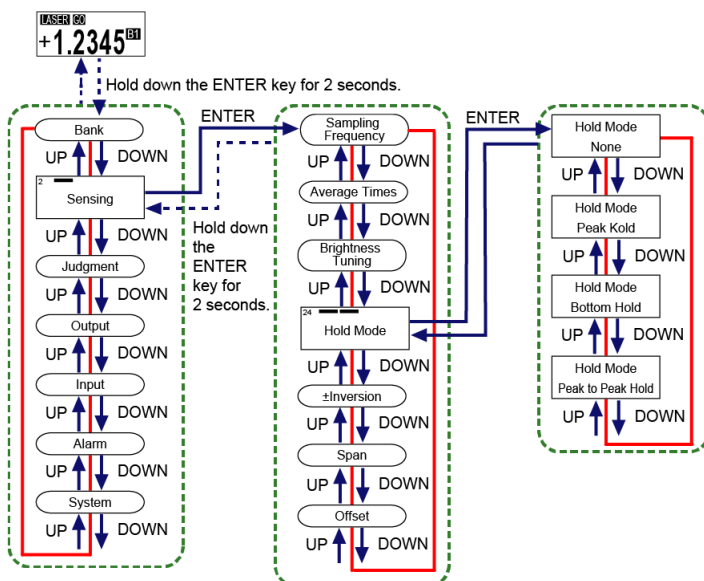

#### Note

- There is a dependency between hold mode and trigger mode. When "None (Normal mode)" is selected in Hold mode, Trigger mode can be set to "Hold" or "One Shot".
- When other than "None (Normal mode)" is selected in Hold mode, Trigger mode can be set to "Hold" only.
- When "One Shot" is selected in Trigger Mode, setting Hold mode to other than "None (Normal mode)" automatically changes the mode to "Hold". For detailed setting procedure, refer to "4.6.3 Trigger Mode".
- Hold down the <ENTER> key for 2 seconds on the setting screen, and the setting change is suspended and the screen returns to the previous display.

Setting item	Set value	Default value
Hold mode	None (Normal mode)	None (Normal mode)
	Peak Hold	
	Bottom Hold	
	Peak to Peak Hold	

The following describes a method to hold the measured value using an external trigger input. When "None (Normal mode)" is selected, the measured value can be held by selecting either one of the following two types: "Hold" or "One Shot".

## 4.3 Sensing Setting

When selecting an item other than "Normal mode", the measured value can be held only by selecting "Hold". For detailed setting procedure, refer to "4.6.3 Trigger Mode".

### Note

- If "One Shot" was selected in "Trigger Mode" and when the hold mode is set to an item other than "None (Normal mode)", selection is automatically changed to "Hold."

### Timing chart

The diagram shown in the following explanation shows an example where "Hold" is set in the trigger mode.

#### None (Normal mode)

When the trigger input turns ON, the measured value is held. When the trigger input turns OFF, the hold state is released, and the value is updated and output as necessary.

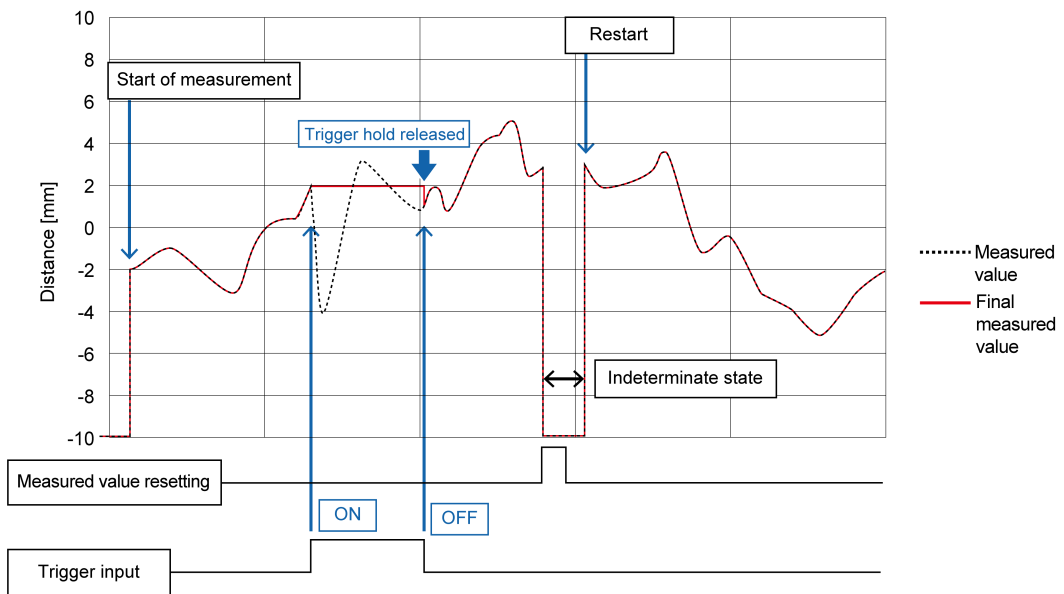

#### Peak Hold

Used to update and output the maximum value of the measured values as needed. During the period from when the trigger input turns ON to when it turns OFF, the maximum value data is held.

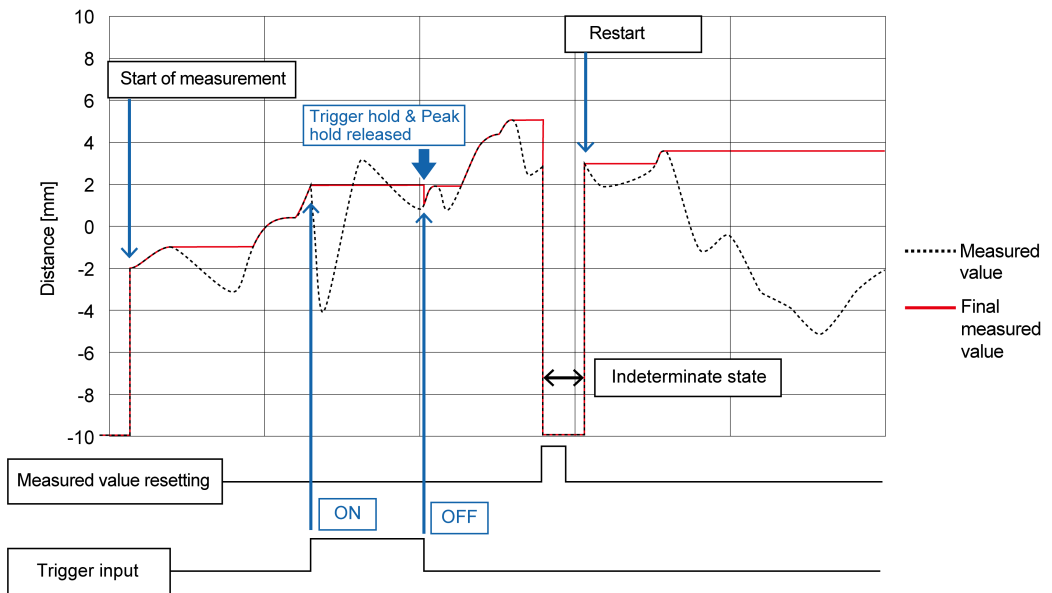

**Bottom Hold**

Used to update and output the minimum value of the measured values as needed. During the period from when the trigger input turns ON to when it turns OFF, the minimum value data is held.

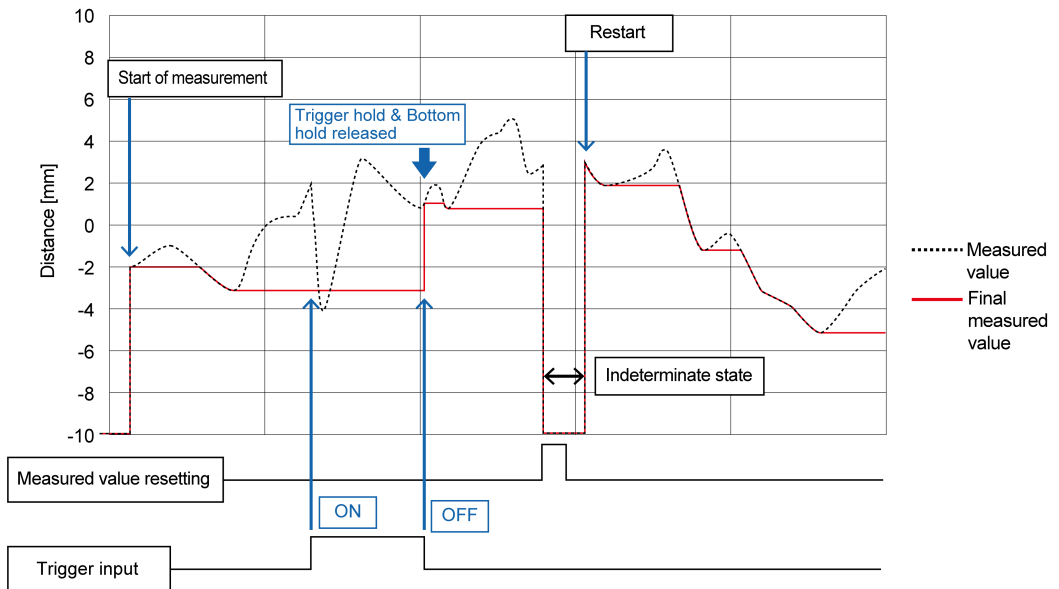

**Peak to Peak Hold**

Used to update and output the value obtained by subtracting the minimum value from the maximum value as needed. During the period from when the trigger input turns ON to when it turns OFF, the value when ON is input is held.

## 4.3 Sensing Setting

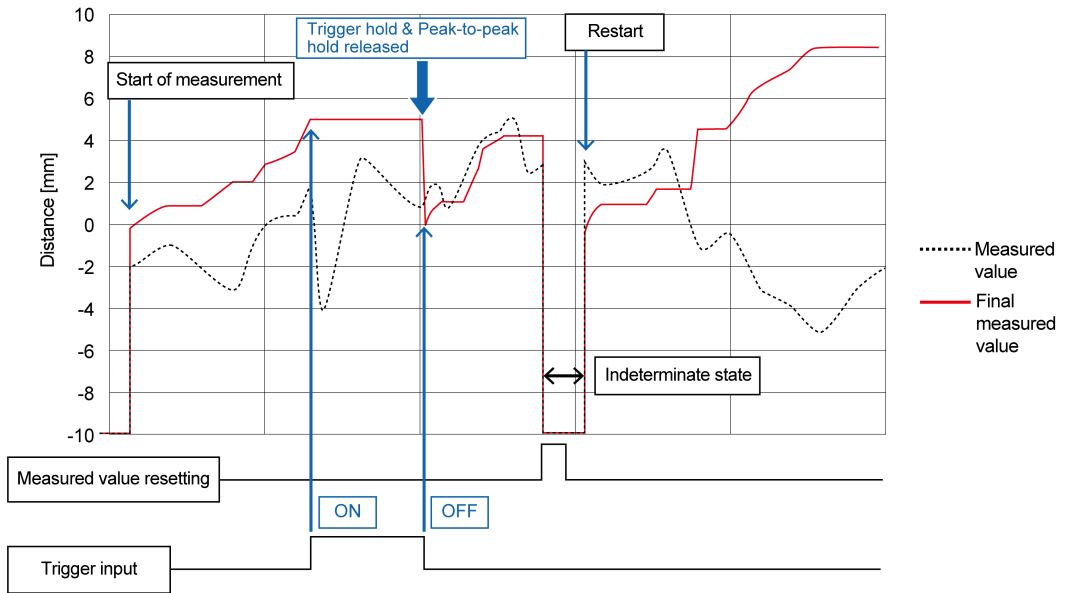

### Note

- In the following cases, the held value is initialized.
  - When the trigger input is turned OFF
  - When Measured value resetting is executed
  - When a setting change is made to cause the measured value to be in an indeterminate state
  - When "All Areas" is executed in Settings initialization



### 4.3.5 Inversion of Measured Value

#### ■ Overview

This is a function that reverses the positive / negative direction of the measured value. When set to "Reverse", only the positive/negative sign of the measured value is reversed.

#### ■ Setting method

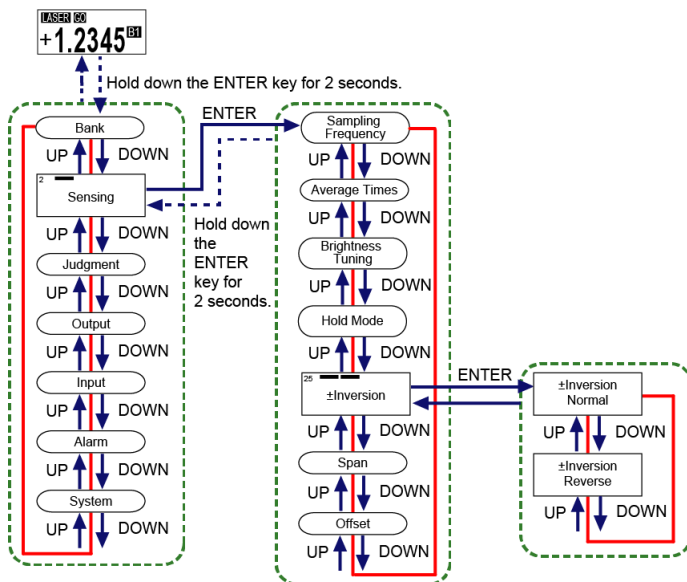

## 4.3 Sensing Setting

### Note

- When set to "Normal", the measured value increases as the workpiece comes closer to this product.

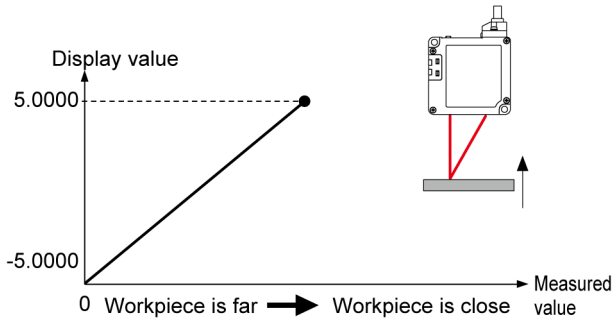

- When set to "Reverse", the measured value decreases as the workpiece comes closer to this product.

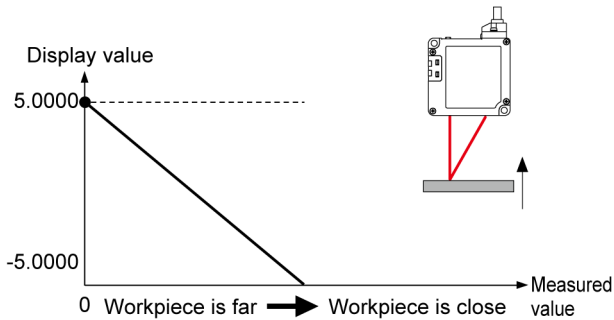

- For the HIGH and LOW measurement values and the zero set correction value, changing the Inversion of Measured Value setting does not change the positive/negative sign.
- Hold down the <ENTER> key for 2 seconds on the setting screen, and the setting change is suspended and the screen returns to the previous display.

Setting item	Set value	Default value
±Inversion	Normal	Normal
	Reverse	

**4.3.6 Span**

■ **Overview**

This is a function that multiplies a span (factor) to the measured value after zero setting and outputs the result.

By adding an optionally set value as the offset, the value is output as the final measured value.

**Final measured value = Span (factor) × Measured value (after zero setting) + Offset**

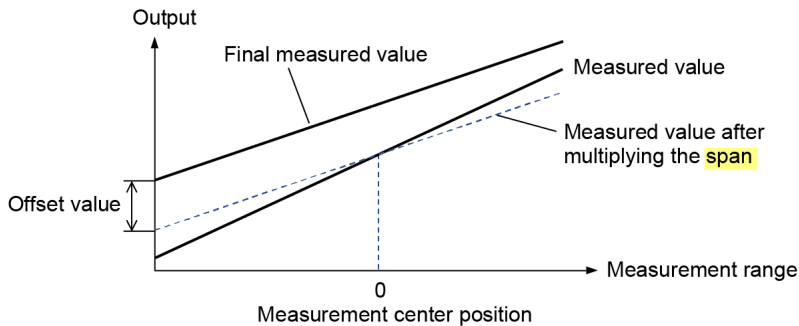

**Note**

- For details on zero setting and offset, refer to "4.3.7 Offset" and "4.10 Zero Setting".

■ **Setting method**

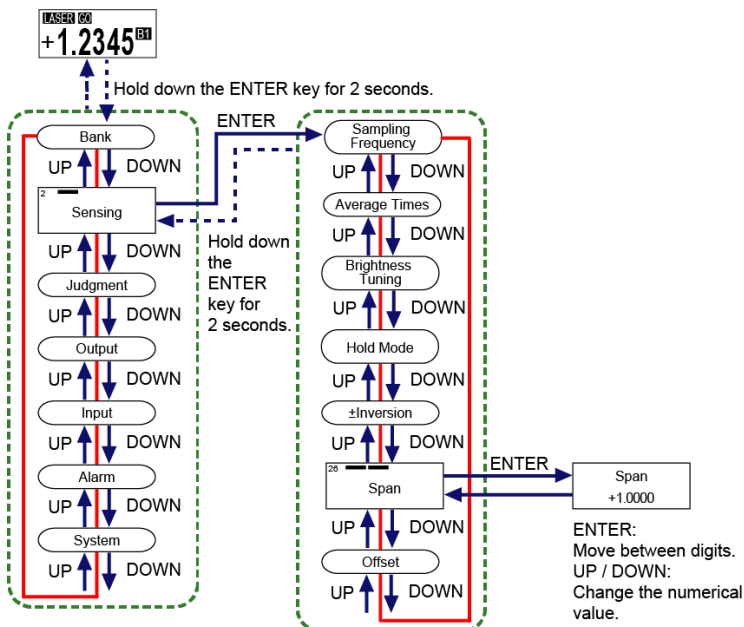

## 4.3 Sensing Setting

---

### Note

- The set value can be set in increments of 0.0001.
- Simultaneously pressing the <UP> and <DOWN> keys while moving between the digits returns to the first digit.
- Hold down the <ENTER> key for 2 seconds on the setting screen, and the setting change is suspended and the screen returns to the previous display.

Setting item	Set value	Default value
Span	+0.1000 to +9.9999	+1.0000

**4.3.7 Offset**

■ **Overview**

This function is used to add or subtract an optional value to/from the measured value.

By multiplying a span (factor) to the measured value after zero setting and by adding an optionally set value as the offset, the value is output as the final measured value.

$$\text{Final measured value} = \text{Span (factor)} \times \text{Measured value (after zero setting)} + \text{Offset}$$

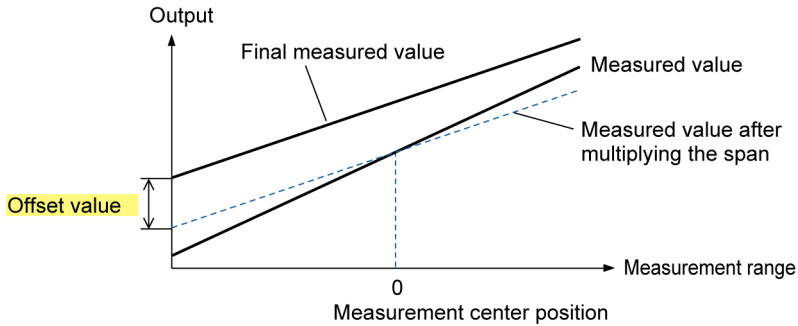

**Note**

- For details on zero setting and span, refer to "4.10 Zero Setting" and "4.3.6 Span".

■ **Setting method**

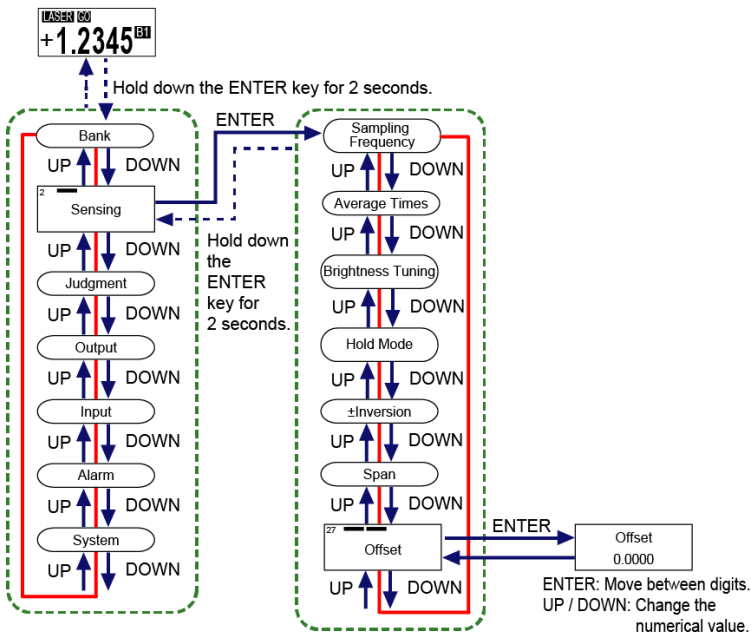

## 4.3 Sensing Setting

---

### Note

- The setting range varies depending on the distance type of this product.
- Simultaneously pressing the <UP> and <DOWN> keys while moving between the digits returns to the first digit (sign).
- Hold down the <ENTER> key for 2 seconds on the setting screen, and the setting change is suspended and the screen returns to the previous display.

Setting item	Distance type	Set value (mm)	Default value (mm)	Setting resolution (μm)
Offset	30 mm	-9.5000 to +9.5000	0.0000	0.1
	50 mm	-95.000 to +95.000		1
	85 mm			
	120 mm			
	250 mm	-950.00 to +950.00		10

## 4.4 Judgment Setting

### ■ Overview

This is a function setting related to judgment results of the measured value.

#### 4.4.1 HIGH Set Value

### ■ Overview

This function allows you to optionally set the upper limit value (HIGH set value) used to judge the measured value.

If the measured value exceeds the HIGH set value, the judgment is output as HIGH.

### ■ Setting method

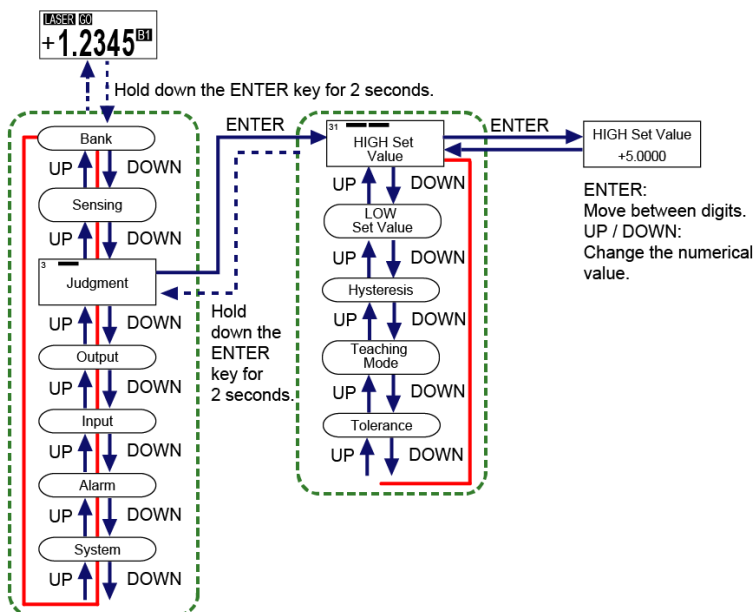

- Be sure to set a HIGH set value that is greater than the LOW set value. If the value is not greater than the LOW set value, an error will occur.
- Set this so that the difference between the HIGH and LOW set values is more than twice the hysteresis. If set to not more than twice the hysteresis, an error will occur.

### Note

- You can set HIGH and LOW set values by teaching.  
For details, refer to "4.4.4 Teaching Mode".
- Hold down the <ENTER> key for 2 seconds on the setting screen, and the setting change is suspended and the screen returns to the previous display.
- In internal processing, comparisons are performed in units of 0.01  $\mu\text{m}$  or less. (Common to all distance types)

## 4.4 Judgment Setting

---

Setting item	Distance type	Set value (mm)	Default value (mm)	Setting resolution (μm)
HIGH set value	30 mm	-9.5000 to +9.5000	+5.0000	0.1
	50 mm	-95.000 to +95.000	+10.000	1
	85 mm		+20.000	
	120 mm		+30.000	
	250 mm	-950.00 to +950.00	+150.00	10



## Setting a "HIGH set value" directly during measurement

### ■ Overview

In addition to the method described in HIGH Set Value, you can also set a HIGH set value directly from the measurement display during measurement.

### 1 2 Procedure

1. Press the <UP> key in the measurement display, and HIGH set value is displayed at the top of the display and a set threshold value is displayed at the bottom.

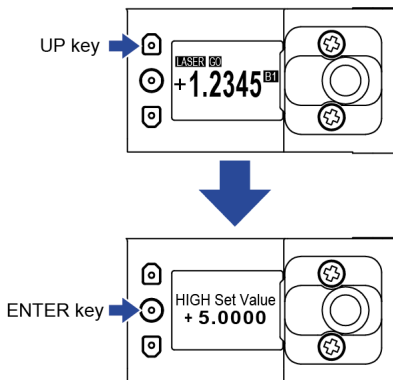

2. Press the <ENTER> key to change the set value. Pressing the <UP>/<DOWN> key increases or decreases the value with the sign changed as needed. Pressing the <ENTER> key moves the digit position, and then pressing the <ENTER> key at the last digit determines the change to the set value.

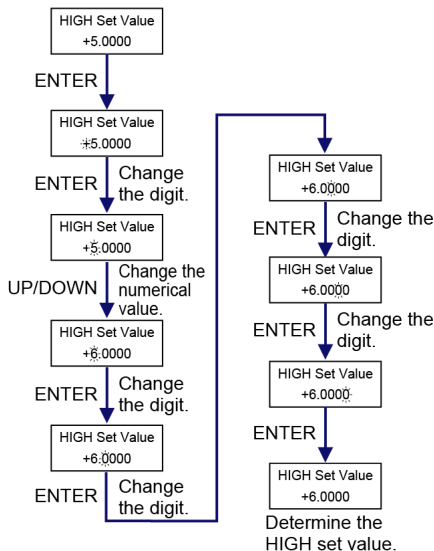

## 4.4 Judgment Setting

---

### Note

- Simultaneously pressing the <UP> and <DOWN> keys while moving between the digits returns to the first digit (sign).

### 4.4.2 LOW Set Value

#### ■ Overview

This function allows you to optionally set the lower limit value (LOW set value) used to judge the measured value.

If the measured value falls below the LOW set value, the judgment is output as LOW.

#### ■ Setting method

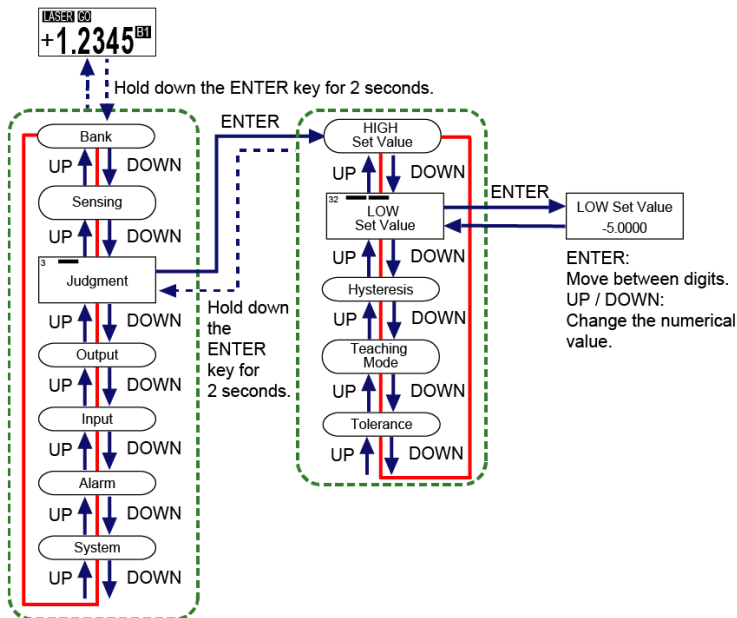

- Be sure to set a LOW set value that is smaller than the HIGH set value. If the value is not smaller than the HIGH set value, an error will occur.
- Set this so that the difference between the HIGH and LOW set values is more than twice the hysteresis. If set to not more than twice the hysteresis, an error will occur.

#### 📄 Note

- You can set HIGH and LOW set values by teaching.  
For details, refer to "4.4.4 Teaching Mode".
- Hold down the <ENTER> key for 2 seconds on the setting screen, and the setting change is suspended and the screen returns to the previous display.
- In internal processing, comparisons are performed in units of 0.01  $\mu\text{m}$  or less. (Common to all distance types)

## 4.4 Judgment Setting

---

Setting item	Distance type	Set value (mm)	Default value (mm)	Setting resolution (μm)
LOW set value	30 mm	-9.5000 to +9.5000	-5.0000	0.1
	50 mm	-95.000 to +95.000	-10.000	1
	85 mm		-20.000	
	120 mm		-30.000	
	250 mm	-950.00 to +950.00	-150.00	10

## Setting a "LOW set value" directly during measurement

### ■ Overview

In addition to the method described in LOW Set Value, you can also set a LOW set value directly from the measurement display during measurement.

### 1 2 Procedure

1. Press the <DOWN> key in the measurement display, and LOW set value is displayed at the top of the display and a set value is displayed at the bottom.

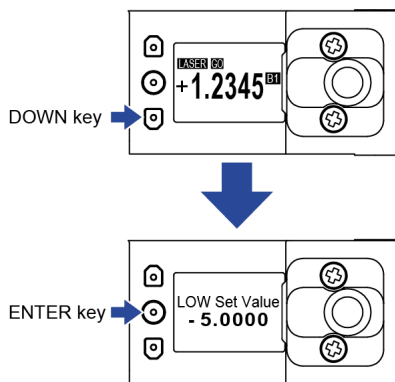

2. Press the <ENTER> key to change the set value. Pressing the <UP>/<DOWN> key increases or decreases the value with the sign changed as needed. Pressing the <ENTER> key moves the digit position, and then pressing the <ENTER> key at the last digit determines the change to the set value.

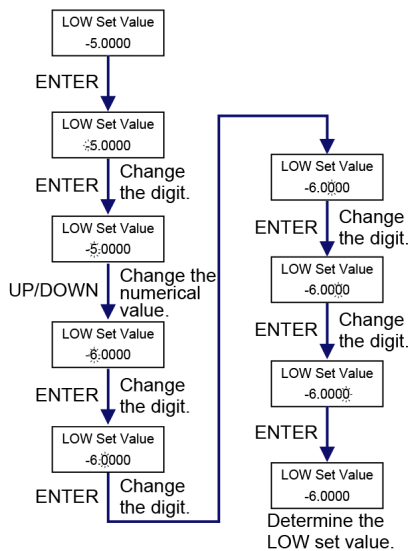

## 4.4 Judgment Setting

---

### Note

- Simultaneously pressing the <UP> and <DOWN> keys while moving between the digits returns to the first digit (sign).

**4.4.3 Hysteresis**

■ **Overview**

If the sensing object vibrates in the vicinity of the HIGH set value / LOW set value, the final measured value may fluctuate, resulting in unstable operation.

When a sensing workpiece is located near the HIGH set value / LOW set value, increasing the value of hysteresis makes output operations stable.

Fluctuates in the vicinity of HIGH set value or LOW set value.

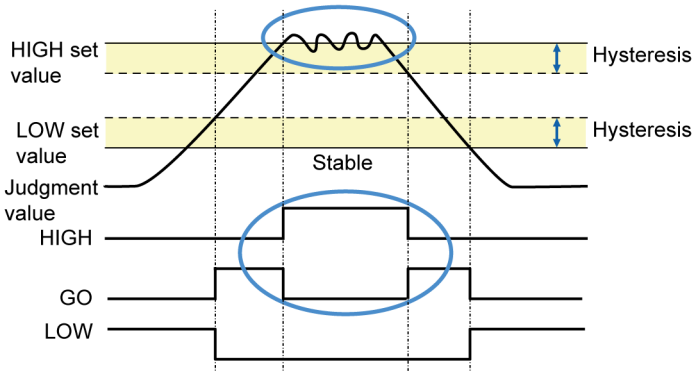

■ **Setting method**

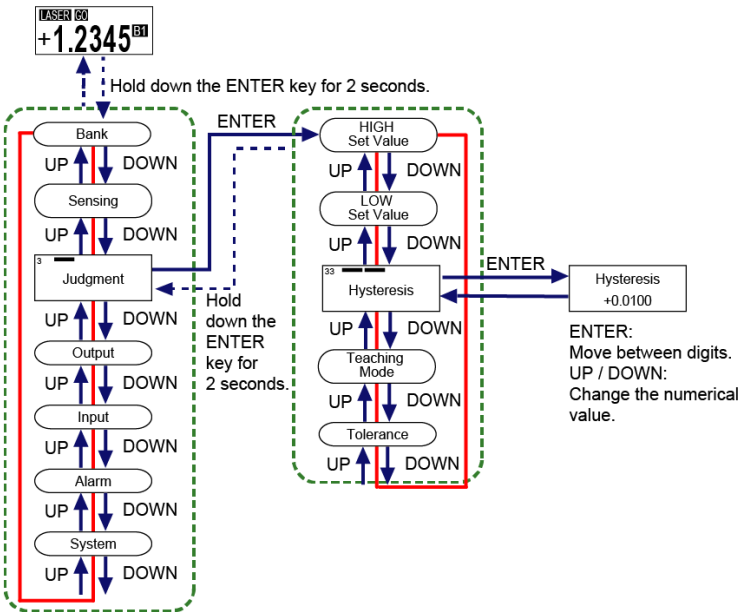

! • Set this so that the difference between the HIGH and LOW set values is more than twice the hysteresis.

## 4.4 Judgment Setting

---

### Note

- The hysteresis setting range varies depending on the distance type of this product.
- Simultaneously pressing the <UP> and <DOWN> keys while moving between the digits returns to the first digit.
- Hold down the <ENTER> key for 2 seconds on the setting screen, and the setting change is suspended and the screen returns to the previous display.

Setting item	Distance type	Set value (mm)	Default value (mm)	Setting resolution ( $\mu\text{m}$ )
Hysteresis	30 mm	0 to +9.5000	+0.0100	0.1
	50 mm	0 to +95.000	+0.020	1
	85 mm		+0.040	
	120 mm		+0.060	
	250 mm	0 to +950.00	+0.30	10



### 4.4.4 Teaching Mode

#### ■ Overview

By teaching using a sensing object, you can automatically set HIGH and LOW set values. You can select the teaching method from one of the following three types.

Set value	Operation	Reference page
1 point teaching	This method is to perform 1-point teaching on the distance from the reference plane of a sensing object and to set HIGH set value / LOW set value.	"4.9.1 1 point Teaching"
2 points teaching	This method is to perform teaching on the reference planes of two sensing objects and set the HIGH set value / LOW set value based on the measured results.	"4.9.2 2 points Teaching"
3 points teaching	This method is to perform teaching on the reference planes of sensing objects 1, 2, and 3 and set the HIGH set value / LOW set value based on the measured results.	"4.9.3 3 points Teaching"

#### 📄 Note

- For details on various teaching methods, refer to "4.9 1 point/2 points/3 points Teaching".

#### ■ Setting method

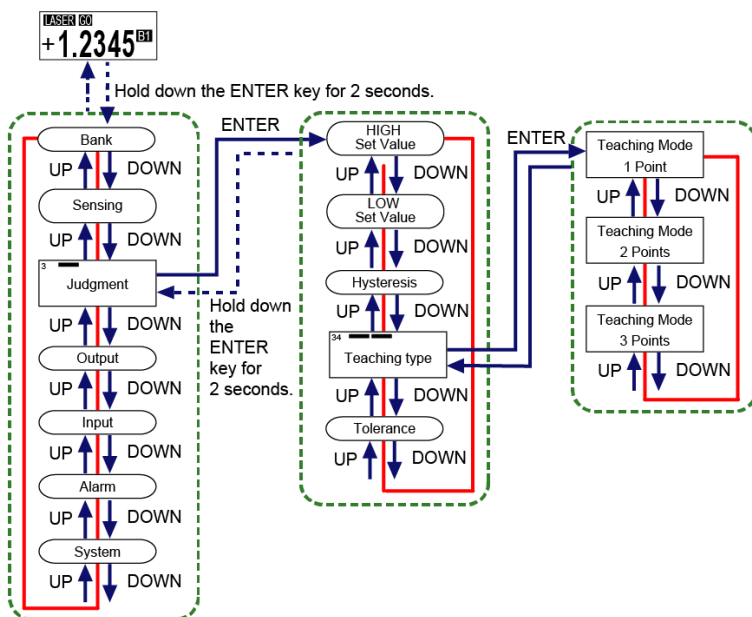

## 4.4 Judgment Setting

---

Setting item	Set value	Default value
Teaching Mode	1 point	1 point
	2 points	
	3 points	

### Note

- Hold down the <ENTER> key for 2 seconds on the setting screen, and the setting change is suspended and the screen returns to the previous display.

### 4.4.5 Tolerance

#### ■ Overview

When 1-point teaching is performed, the measured value of the master workpiece plus the tolerance can be set as the HIGH set value and the measured value of the master workpiece minus the tolerance can be set as the LOW set value.

This is valid only when 1-point teaching is set.

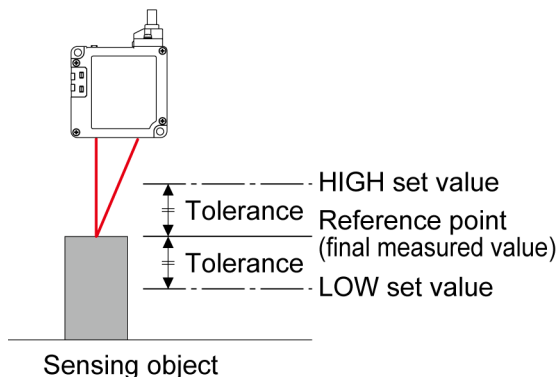

#### ■ Setting method

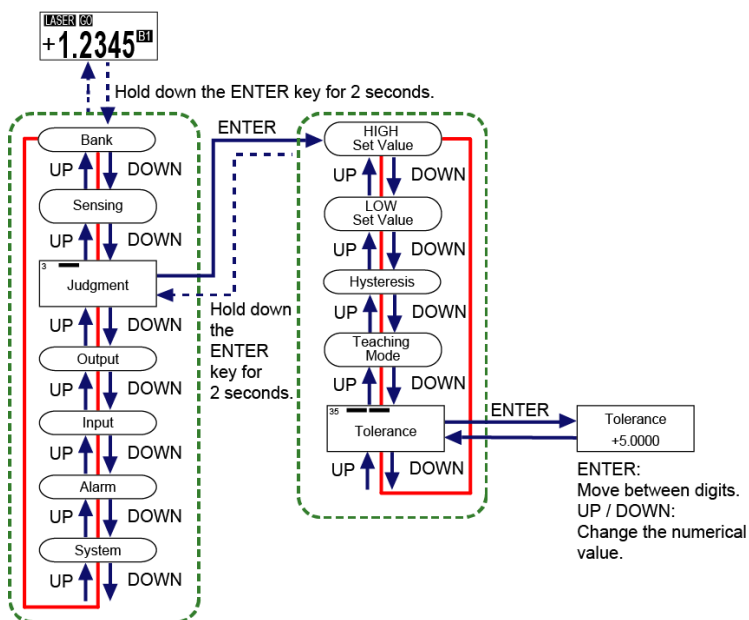

- Changing the tolerance setting does not update the HIGH and LOW set values. After changing the setting, execute 1-point teaching again.

## 4.4 Judgment Setting

---

### Note

- You cannot set this to a value that is equal to or less than the hysteresis.
- Hysteresis can be set regardless of the tolerance value. Depending on the set value, 1-point teaching may fail.
- Simultaneously pressing the <UP> and <DOWN> keys while moving between the digits returns to the first digit.
- Hold down the <ENTER> key for 2 seconds on the setting screen, and the setting change is suspended and the screen returns to the previous display.

Setting item	Distance type	Set value (mm)	Default value (mm)	Setting resolution (μm)
Tolerance	30 mm	0.0001 to 9.5000	+2.0000	0.1
	50 mm	0.001 to 95.000	+5.000	1
	85 mm	0.001 to 95.000	+10.000	
	120 mm	0.001 to 95.000	+15.000	
	250 mm	0.01 to 950.00	+100.00	10

## 4.5 Output Setting

### ■ Overview

This is a function setting related to output operation.

### 4.5.1 Judgment Output

This function allows you to select a combination of signals to be output from external OUT1, OUT2, and OUT3 from four types. This product is equipped with an alarm signal output function. When this product does not operate correctly, alarm signals enable you to take prompt action.

### ■ Judgment output (External output line OUT1/OUT2/OUT3 control)

Judgment output	Output line operation			
	OUT1	OUT2	OUT3	
3-State	Judgment 1	Judgment 2	Judgment 3	OUT1(HI) ON (Open) → Output state (ON) between Lo and Hi OFF → Output state (OFF) elsewhere OUT2(GO) ON (Open) → Output state (ON) between Lo and Hi OFF → Output state (OFF) elsewhere OUT3(LO) ON (Open) → Output state (ON) between 0 and Lo OFF → Output state (OFF) elsewhere
Logic	Judgment 1	Judgment 2	Alarm	OUT1 ON (Open) → Output state (ON) between Lo and Hi OFF → Output state (OFF) elsewhere OUT2 ON (Open) → Output state (ON) between 0 and Lo OFF → Output state (OFF) elsewhere
Independent	Judgment 1	Judgment 2	Alarm	OUT1 ON (Open) → Output state (ON) between Lo and Hi OFF → Output state (OFF) elsewhere OUT2 ON (Open) → Output state (ON) between 0 and Lo OFF → Output state (OFF) elsewhere
2-State	Judgment 1	Judgment 2	Alarm	OUT1 ON (Open) → Output state (ON) between Lo and Hi OFF → Output state (OFF) elsewhere OUT2 ON (Open) → Output state (ON) between 0 and Lo OFF → Output state (OFF) elsewhere

### Note

- For details on alarm setting methods, refer to "4.7 Alarm Setting".

## 4.5 Output Setting

### ■ Setting method

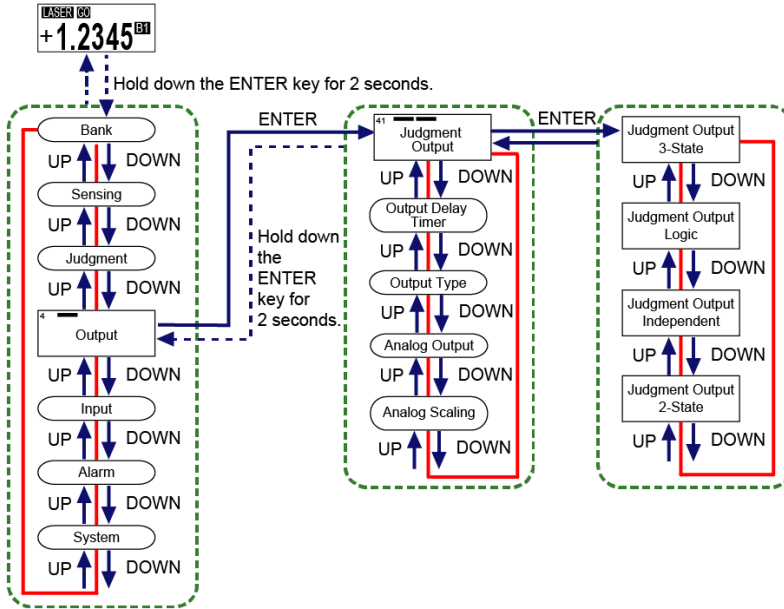

Setting item	Set value	Default value
Judgment output	3-State	3-State
	Logic	
	Independent	
	2-State	

### 📌 Note

- Hold down the ENTER key for 2 seconds on the setting screen, and the setting change is suspended and the screen returns to the previous display.

**4.5.2 Output Delay Timer Selection**

**■ Overview**

This setting is used to set the timing from ON to OFF or from OFF to ON for the measured value judgment result (HIGH / GO/ LOW).

Set value	Operation
OFF (No timer)	No change is made in the timing for the measured value judgment result.
On Delay	When the measured value judgment result is turned ON from OFF, the ON output is delayed for the timer's time.
Off Delay	When the measured value judgment result is turned OFF from ON, the OFF output is delayed for the timer's time.
One Shot	When the measured value judgment result is turned ON from OFF, the ON output is held for the timer's time and then OFF output is given.
Hold	The output signal is held for a period from when sensing is started to when the measured value reset input is turned ON.

**Note**

- When the output delay timer or timer's time is changed during output delay operation, the changed set value is reflected when the output is changed next time.

**■ Setting method**

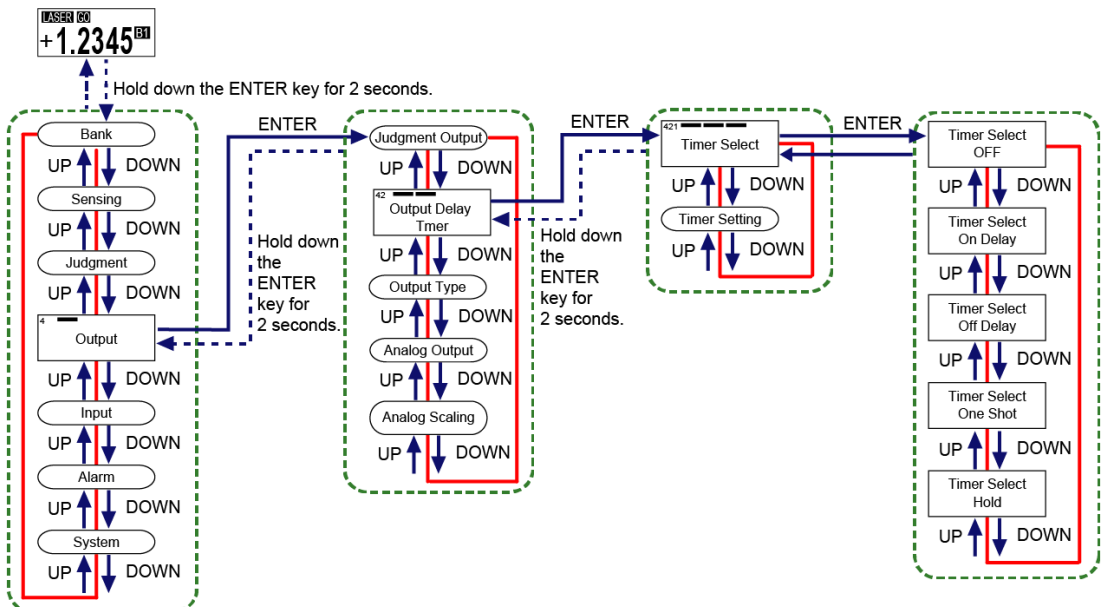

**Note**

- Hold down the <ENTER> key for 2 seconds on the setting screen, and the setting change is suspended and the screen returns to the previous display.

## 4.5 Output Setting

Setting item	Set value	Default value
Timer selection	OFF (No timer)	OFF (No timer)
	On Delay	
	Off Delay	
	One Shot	
	Hold	

### ■ OFF (No timer)

When the output operation setting is set to light-ON and the sensing output setting is set to normal sensing, the measured value judgment result will be as shown in the following diagram.

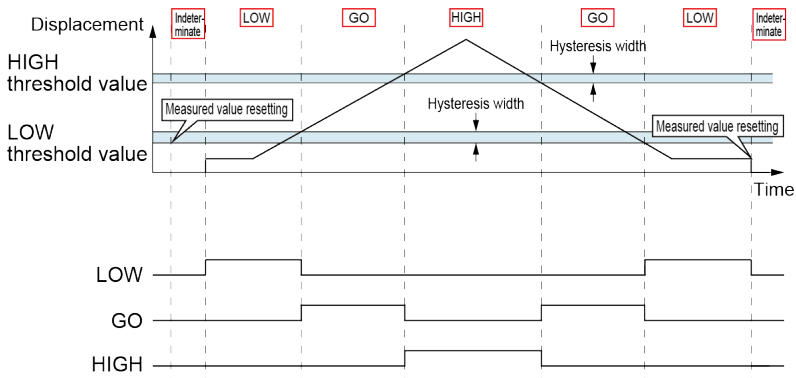

### On Delay

When set to "On Delay", the output will be delayed for the timer's time from the time when the judgment result is turned ON.

If the ON duration is less than the timer's time, the delay does not appear in the measured value judgment result.

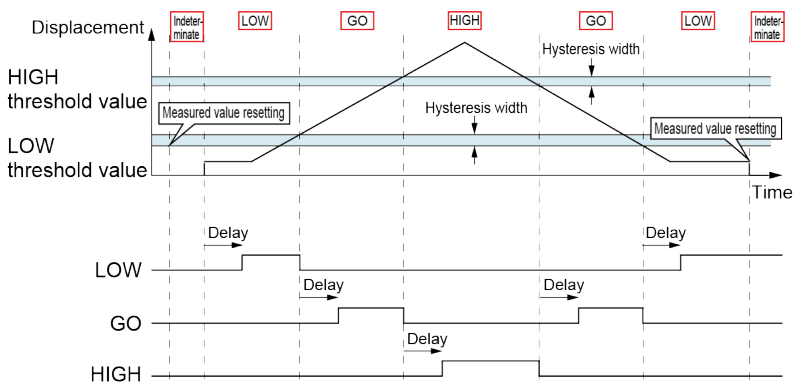



### Off Delay

When set to "Off Delay", the output will be delayed for the timer's time from the time when the judgment result is turned OFF.

If the OFF duration is less than the timer's time, the delay does not appear in the measured value judgment result.

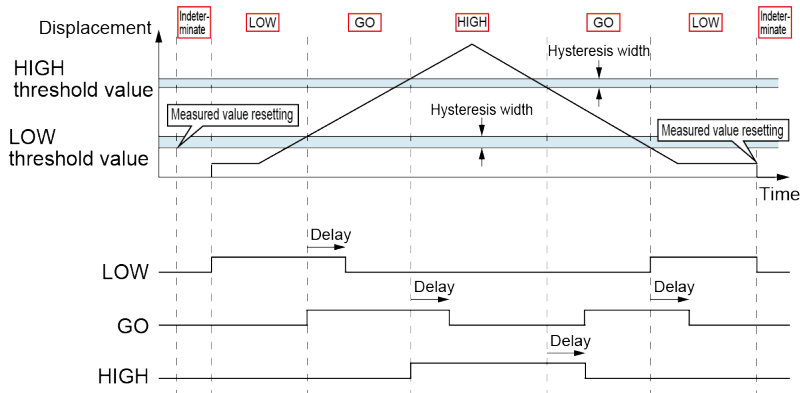

### One Shot

When set to "One Shot", the the output will be generated for the timer's time.

If the judgment result changes from OFF to ON again while the ON output is held, the ON time will not be extended because the change is not reflected in it.

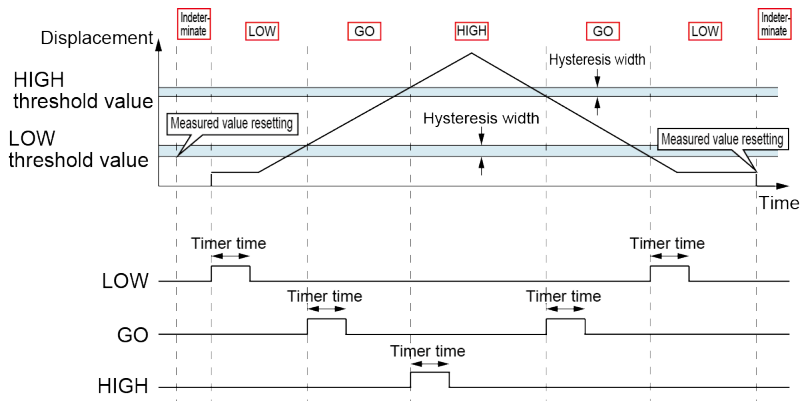

## 4.5 Output Setting

### Hold

When set to “Hold”, the measured value is held at the ON timing and the hold state is released at the OFF timing.

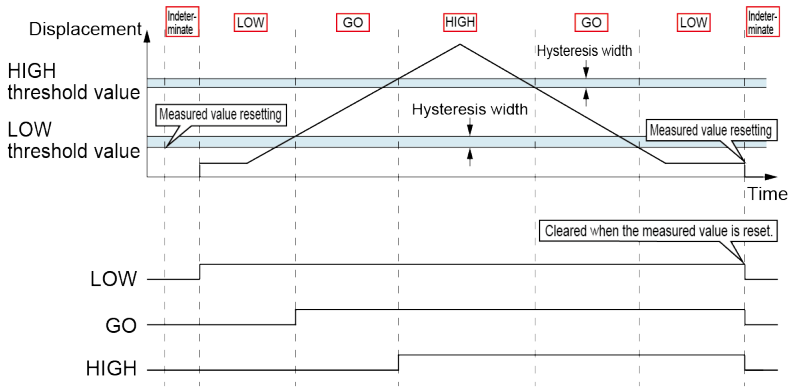

### 4.5.3 Output Delay Timer Setting

#### ■ Overview

This setting is used to set the delay time in milliseconds for the output delay timer selected in "4.5.2 Output Delay Timer Selection".

#### ■ Setting method

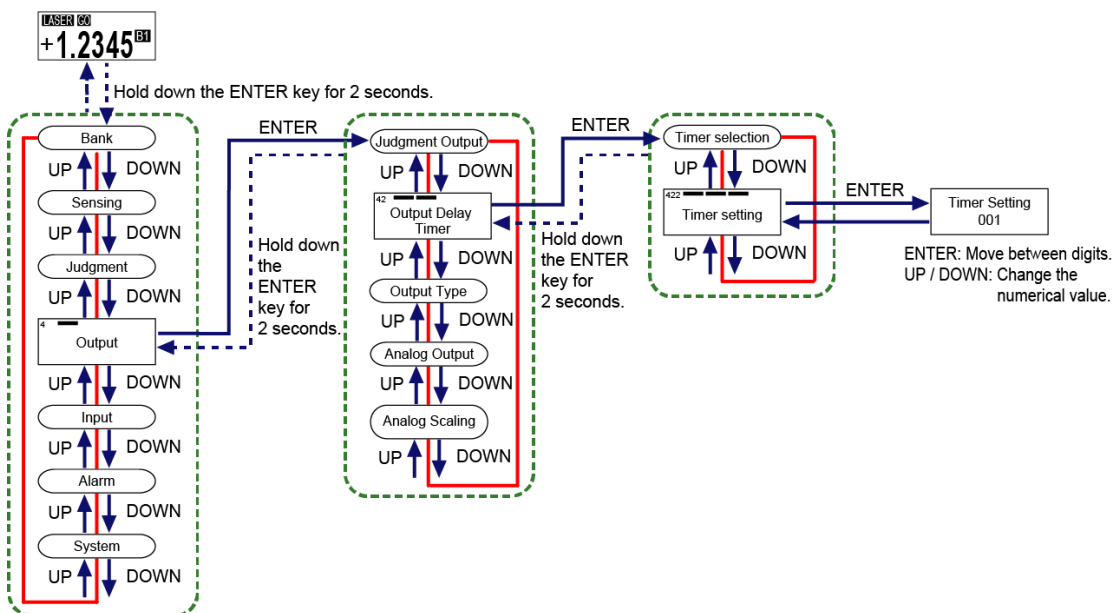

#### Note

- The output delay timer setting is reflected only when "Off Delay", "On Delay", or "One Shot" is selected in Output delay timer selection.  
The output delay timer setting is not reflected when "OFF (No timer)" or "Hold" is selected.
- The set timer time value is shared by all output delay timer settings.
- Simultaneously pressing the <UP> and <DOWN> keys while moving between the digits returns to the first digit.
- Hold down the <ENTER> key for 2 seconds on the setting screen, and the setting change is suspended and the screen returns to the previous display.

Setting item	Set value (ms)	Default value (ms)
Timer Setting	1 to 100	1

## 4.5 Output Setting

### 4.5.4 Output Type

This function allows you to select the operation of judgment output.

Set value	Operation
Normally open (N.O.)	Outputs ON when judgment output is ON.
Normally closed (N.C.)	Outputs OFF when judgment output is ON.

#### Example of output type settings (for GO output)

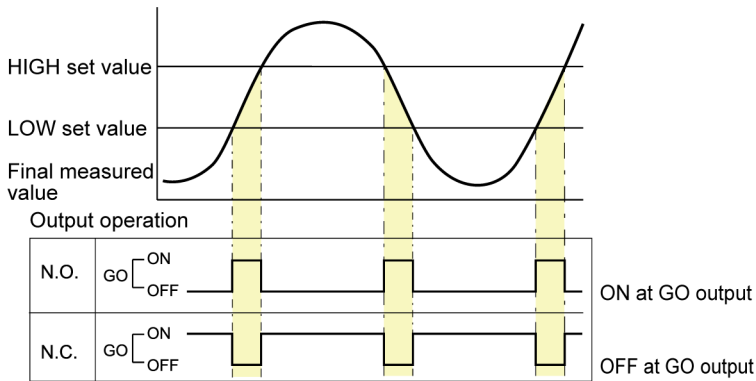

#### Setting method

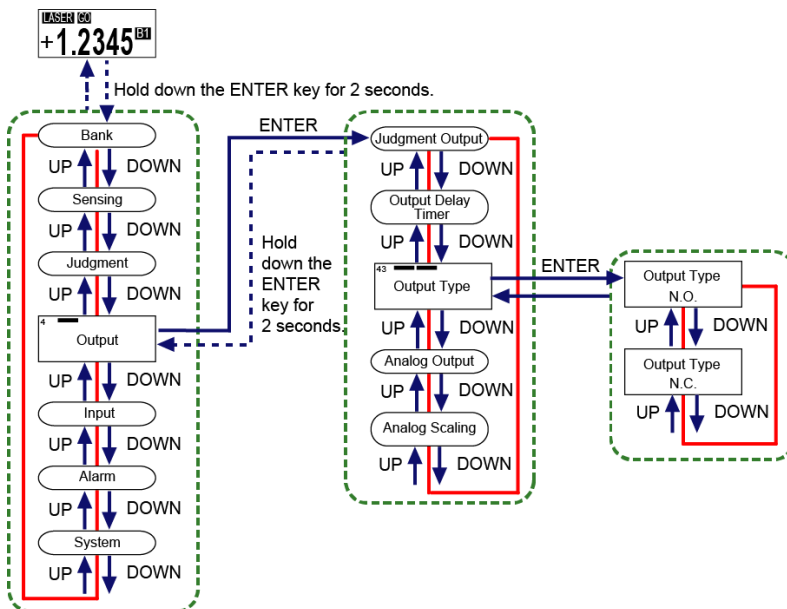

Setting item	Set value	Default value
Output type	N.O. (Normally Open)	N.O.
	N.C. (Normally Closed)	

### 4.5.5 Analog Output

This function allows you to select the output operation of analog output, which is OFF, Voltage, or Current.

Output operation	Operation description	Normal output range	Indeterminate value	Alarm	Error output
OFF	Turns OFF the analog output function.	0 mA/0 V	0 mA/0 V	0 mA/0 V	0 mA/0 V
Current	Sets analog output to current.	3.2 mA to 20.8 mA	23 mA	22 mA	0 mA
Voltage	Sets analog output to voltage.	0 V to +5.25 V	+5.5 V	+5.3 V	0 V

#### Setting method

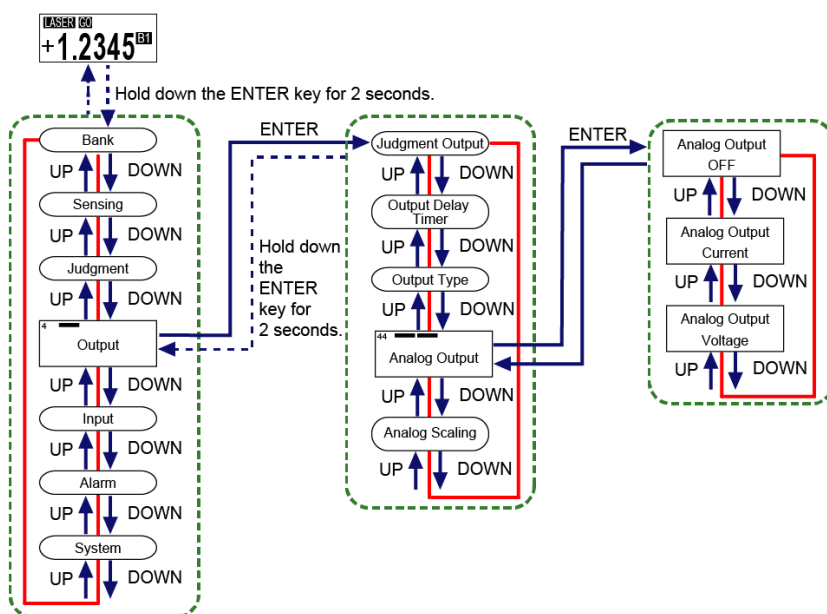

Setting item	Set value	Default value
Analog Output	OFF	OFF
	Current	
	Voltage	

#### Note

- The output operation selected in "3.6 Initial Startup Settings" is displayed first after the setting.

## 4.5 Output Setting

### 4.5.6 Analog Scaling

#### ■ Overview

This function allows you to scale analog current output or analog voltage output to any value. By setting optional two points as measured value "A" and measured value "B", the values of those optional points can be scaled to analog current output "a" and "b" or analog voltage output "a" and "b". Analog output is produced by the scaling set in Analog Output.

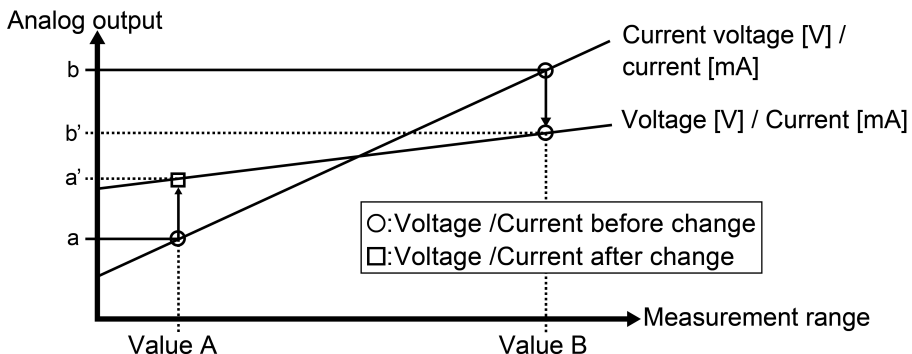

#### 📌 Note

- When "OFF" is selected in Analog Output, Analog scaling will not be displayed on the Setting mode selection screen.

#### ■ Setting method

The setting range and default value are shown in the following table. Note that the listed values vary depending on models.

Item	Display section	Distance type	Set value (mm)	Default value (mm)
Value A	Value A - 5.0000	30 mm	-9.5000 to +9.5000	-5.0000
		50 mm	-95.000 to +95.000	-10.000
		85 mm		-20.000
		120 mm		-30.000
		250 mm	-950.00 to +950.00	-150.00
Value B	Value B + 5.0000	30 mm	-9.5000 to +9.5000	+5.0000
		50 mm	-95.000 to +95.000	+10.000
		85 mm		+20.000
		120 mm		+30.000
		250 mm	-950.00 to +950.00	+150.00

Item	Display section	Setting range (mA)	Default value (mA)
Current a <sup>(Note 1)</sup>	Current A 04.000	4.000 to 20.000	4.000
Current b <sup>(Note 1)</sup>	Current B 20.000		20.000

(Note 1) If "Voltage" is selected in Analog Output, this item is not displayed.

Item	Display section	Setting range (V)	Default value (V)
Voltage a (Note 1)	Voltage A 0.000	0.000 to 5.000	0.000
Voltage b (Note 1)	Voltage B 5.000		5.000

(Note 1) If "Current" is selected in Analog Output, this item is not displayed.

- Make sure to set values so that the measured values do not exceed the measured value display range on the measurement display.
- Set Measured value B to a value greater than Measured value A.
- Set Current b to a value greater than Current a.
- Set Voltage b to a value greater than Voltage a.

### Note

- Change the set value for one digit at a time by pressing the <ENTER key> from the leftmost position. Press the <ENTER> key to move the digit position. Press the <UP>/<DOWN> key to increase or decrease the value.

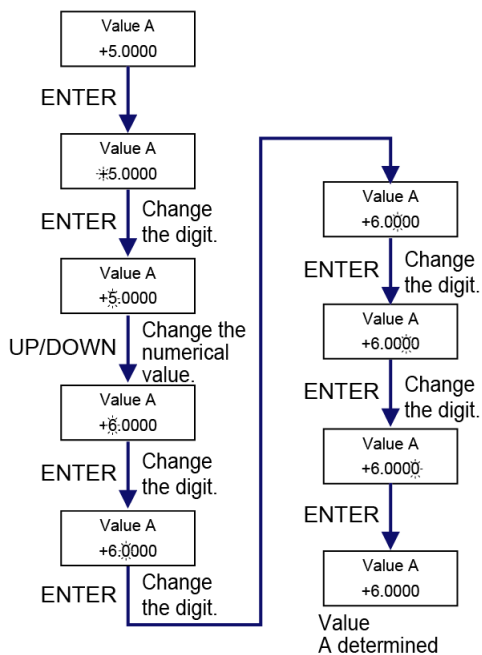

## 4.5 Output Setting

### Current value setting

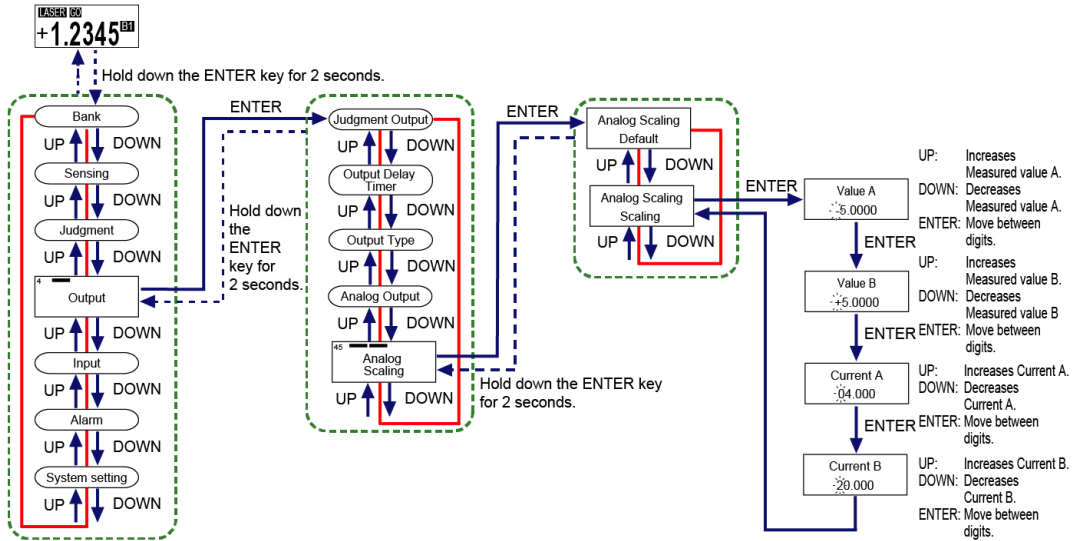

### Voltage value setting

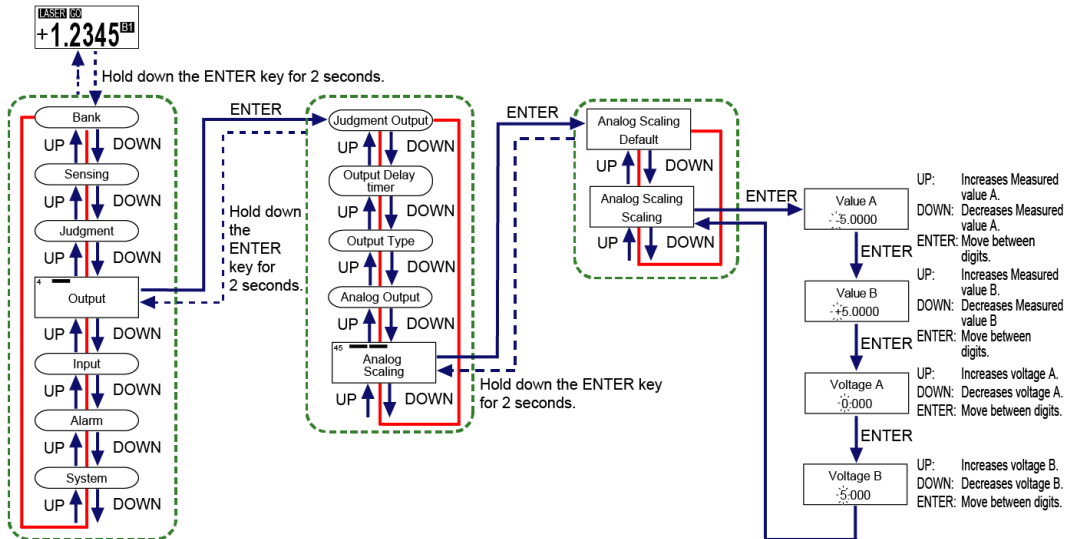

### Note

- When changing the settings in Analog Output and Analog Scaling, the analog output remains OFF or indeterminate state for a fixed period and the output value may not change as set depending on the timing.
- Simultaneously pressing the <UP> and <DOWN> keys while moving between the digits returns to the first digit. For Measured value a and Measured value b, doing so returns to the sign.
- Hold down the <ENTER> key for 2 seconds on the setting screen, and the setting change is suspended and the screen returns to the previous display.



## 4.6 Input Setting

### ■ Overview

This is a function setting related to input operation.

### 4.6.1 Input Line Operation Selection

This function allows you to select a combination of signals to be input to external IN1, IN2, and IN3 from five types.

#### Zero setting

Zero point adjustment can be made.

For details, refer to ["4.10 Zero Setting"](#).

#### Measured value resetting

When a reset signal is input, measured values, calculated values, and other values are reset.

For details, refer to ["4.11 Measured Value Resetting"](#).

#### Trigger

If a trigger signal is input, the measured value is held while the signal is being input.

For details, refer to ["4.6.3 Trigger Mode"](#).

#### Bank A / B

The contents of each bank can be read by combining bank A input and bank B input.

For details on the combination of each bank input, refer to "Bank A / Bank B input" in ["Input line operation"](#).

#### Laser stop

While a laser stop signal is being input, laser radiation is stopped.

#### Teaching

When a teaching signal is input, teaching is performed on the sensing object.

External input setting combinations are shown below.

External input	Input signal combinations		
	IN1 (Pink)	IN2 (Purple)	IN3 (Pink / Purple)
Trigger / Zero setting / Measured value resetting (Trg / Zero / Reset)	Trigger	Zero setting	Measured value resetting
Trigger / Zero setting / Laser stop (Trg / Zero / Laser)	Trigger	Zero setting	Laser stop
Trigger / Bank A / Bank B (Trg / Bank)	Trigger	Bank A	Bank B
Teaching / Bank A / Bank B (Teach / Bank)	Teaching	Bank A	Bank B
Zero setting / Bank A / Bank B (Zero / Bank)	Zero setting	Bank A	Bank B

## 4.6 Input Setting

### Note

- For I/O circuit diagrams of this product, refer to "I/O circuit diagram".

### Setting method

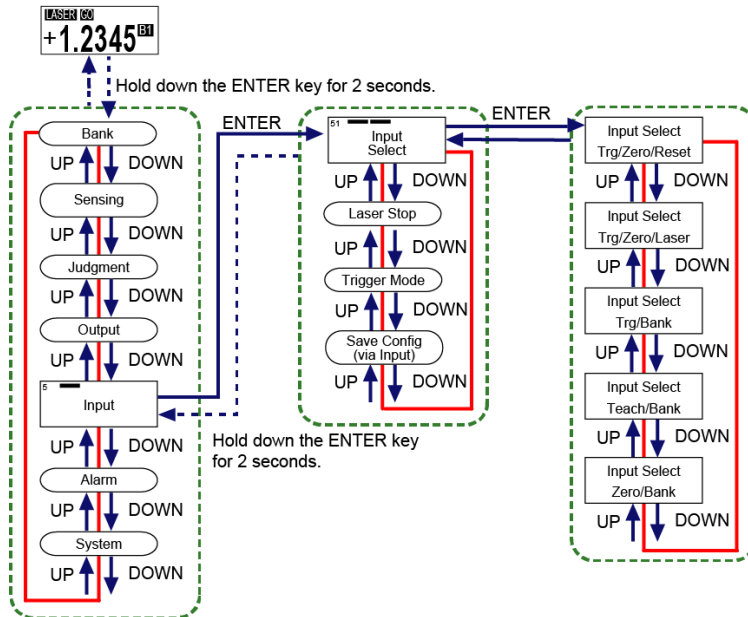

Setting item	Set value	Default value
Input line operation selection	Trg/Zero/Reset (Trigger / Zero setting / Measured value resetting)	Trg/Zero/Reset
	Trg/Zero/Laser (Trigger / Zero setting / Laser stop)	
	Trg/Bank (Trigger / Bank A / Bank B)	
	Teach/Bank (Teaching / Bank A / Bank B)	
	Zero/Bank (Zero setting / Bank A / Bank B)	

Input line operation

■ Minimum input time

The minimum input time and standby time differ according to the input type.

Zero setting input

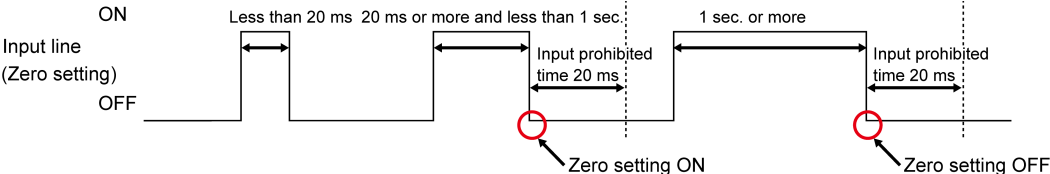

The operation of zero setting differs depending on the input line ON time.  
No operation if ON time is less than 20 ms  
Zero setting ON if falling edge from ON to OFF is detected after input ON time of 20 ms or more and less than 1 sec.  
Zero setting OFF operation if falling edge from ON to OFF is detected after input ON time of 1 sec. or more

Measured value resetting input

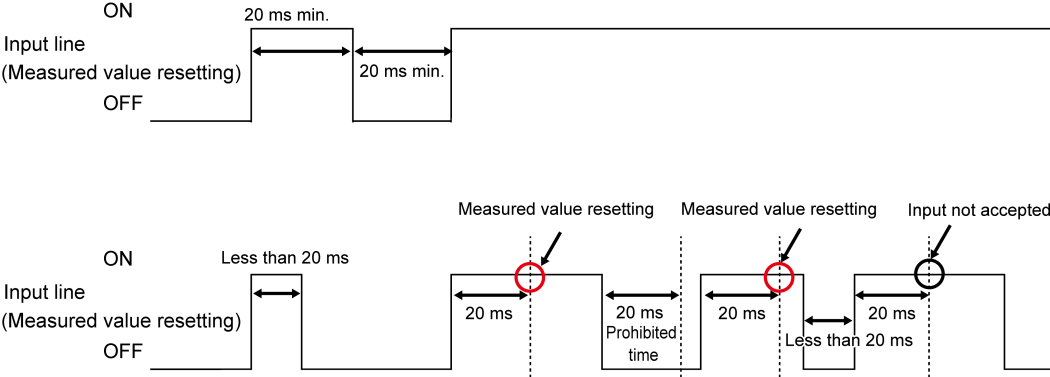

No operation if ON time is less than 20 ms  
Measured value resetting if ON time is 20 ms or more

## 4.6 Input Setting

### Trigger input

- Hold

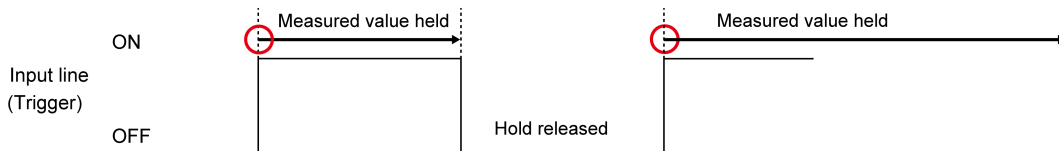

\* When set to Hold, measured values are held only when trigger input is ON.

- One Shot

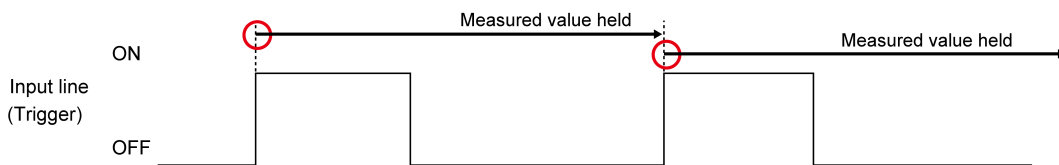

\* When set to One Shot, measured value being held is refreshed when trigger turns ON.



- Trigger input by "IN 1 (trigger input)" on the Input line must be continued for at least 2 ms.

### Bank A / Bank B input

When "Bank A/B" (using 2 lines) is assigned to the input line function, input operations are as follows.

Bank setting	Bank A	Bank B
Bank 1	OFF	OFF
Bank 2	ON	OFF
Bank 3	OFF	ON
Bank 4	ON	ON

The procedure for bank switching is described below.

1. Since both Bank A and Bank B are OFF, Bank 1 is used.
2. If Bank A changes from OFF to ON and Bank B changes from OFF to ON within the bank switching delay time (50 ms), the bank is switched to Bank 4 when the bank switching delay time (50 ms) has elapsed after Bank B changed to ON.
3. The bank is switched to Bank 1 when the bank switching delay time (50 ms) has elapsed after Bank A and Bank B changed from ON to OFF.
4. The bank is switched to Bank 2 when the bank switching delay time (50 ms) has elapsed after Bank A changed from OFF to ON.

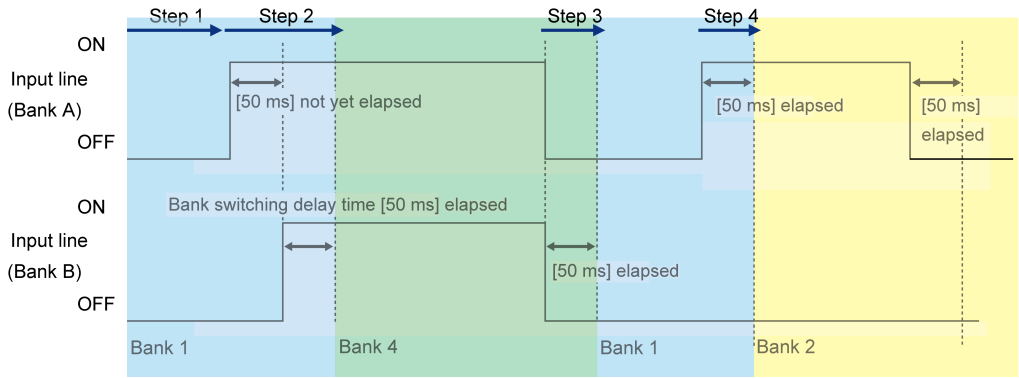

- 5. If Bank A changes from ON to OFF within the bank switching prohibition time (50 ms) after switching to Bank 4 in step 2, the bank is switched to Bank 3 when the bank switching prohibition time and the bank switching delay time have elapsed.

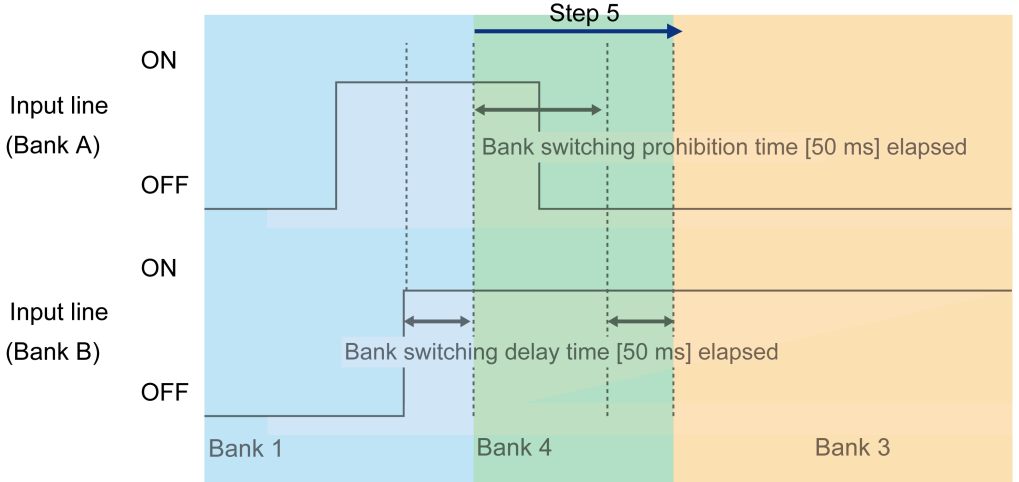

## 4.6 Input Setting

### Laser stop input

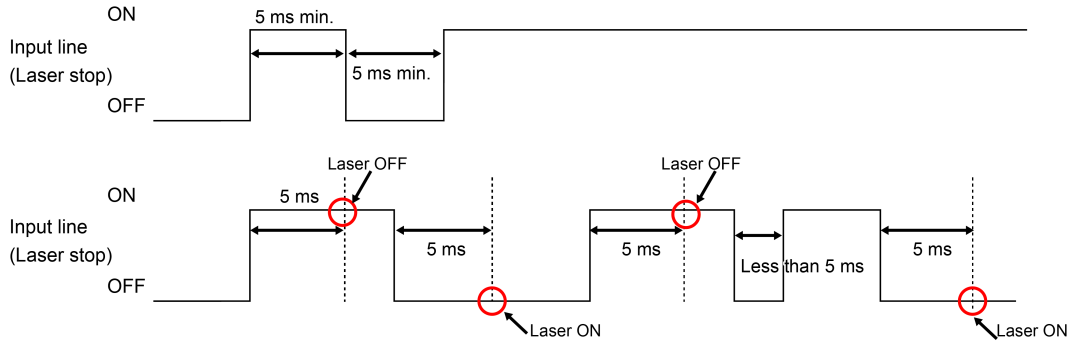

### Teaching input

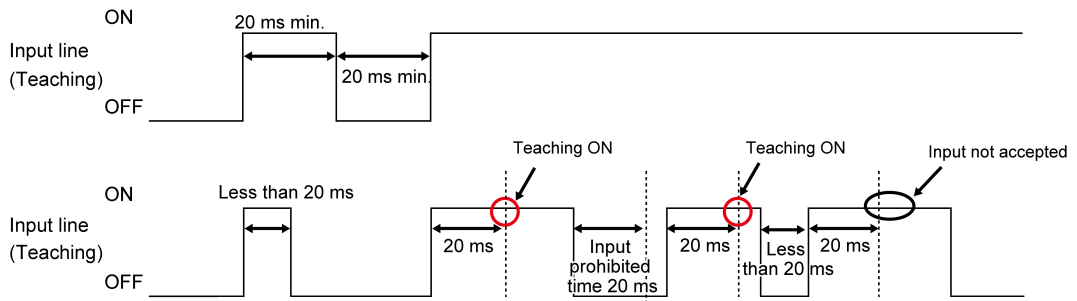

No operation if ON time is less than 20 ms  
Teaching if ON time is 20 ms or more  
Input is not accepted for 20 ms from input ON to OFF.

## 4.6.2 Laser Stop

### ■ Overview

This is a function that switches ON and OFF the laser emission.

When the setting is OFF, laser will be emitted. When it is ON, laser emission will be stopped.

### ■ Setting method

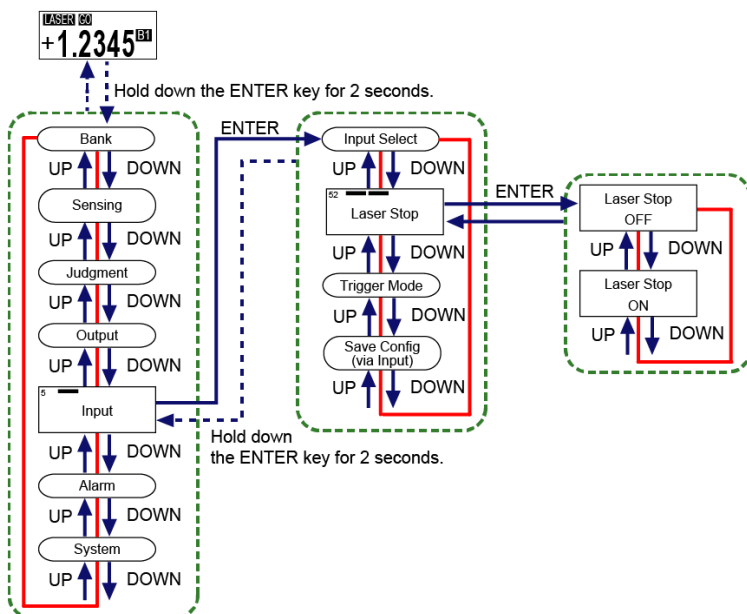

### 📄 Note

- Hold down the <ENTER> key for 2 seconds on the setting screen, and the setting change is suspended and the screen returns to the previous display.

Setting item	Set value	Default value
Laser Stop	OFF (Laser emitted)	OFF
	ON (Emission stopped)	

## 4.6 Input Setting

### 4.6.3 Trigger Mode

The following describes a method to hold the final measured value using a trigger input. This mode can be selected from the following two types: "Hold" or "One Shot".

#### ■ Hold

If trigger input turns ON, this function holds the final measured value while the input is ON.

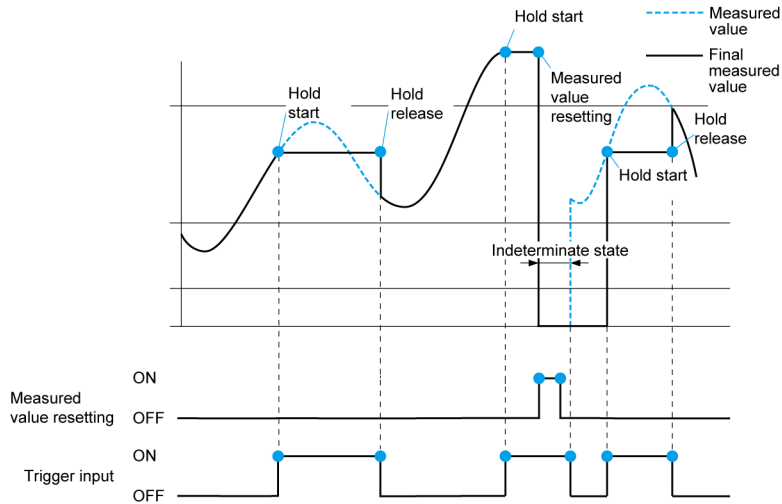

#### ■ One Shot

Each time trigger input turns ON (rising edge), this function updates and holds the final measured value.

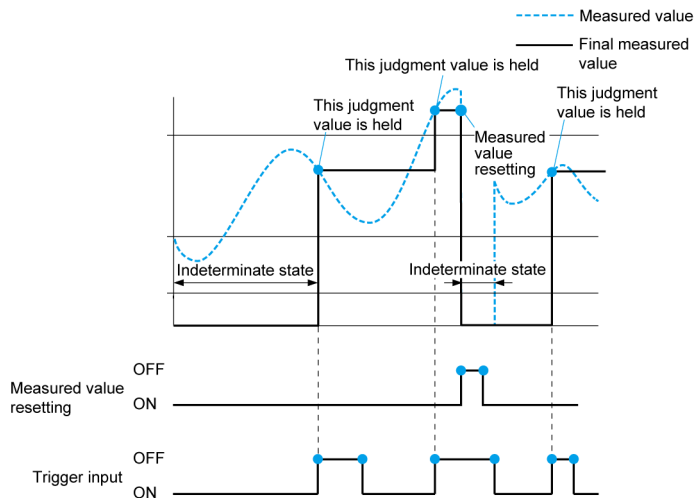



## ■ Setting method

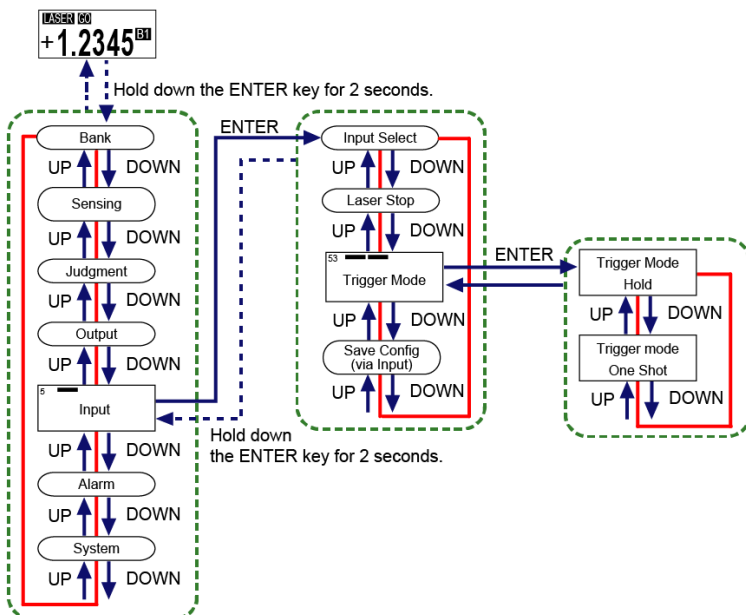

### Note

- Trigger mode can be set to "One Shot" only when "None (Normal mode)" is selected in Hold mode.
- The hold releasing conditions are as follows.
  - When a setting change is made to cause the measured value to be in an indeterminate state
  - When "All Areas" is executed in Settings initialization
- Hold down the <ENTER> key for 2 seconds on the setting screen, and the setting change is suspended and the screen returns to the previous display.

Setting item	Set value	Default value
Trigger mode	Hold	Hold
	One Shot	

## 4.6 Input Setting

### 4.6.4 Input Line Saving Setting

#### ■ Overview

The set values changed by the function selected in Input line operation selection will not normally be saved. However, when this function is set to ON, the zero setting (ON/OFF) and the HIGH set value / LOW set value by teaching will be saved.

#### ■ Setting method

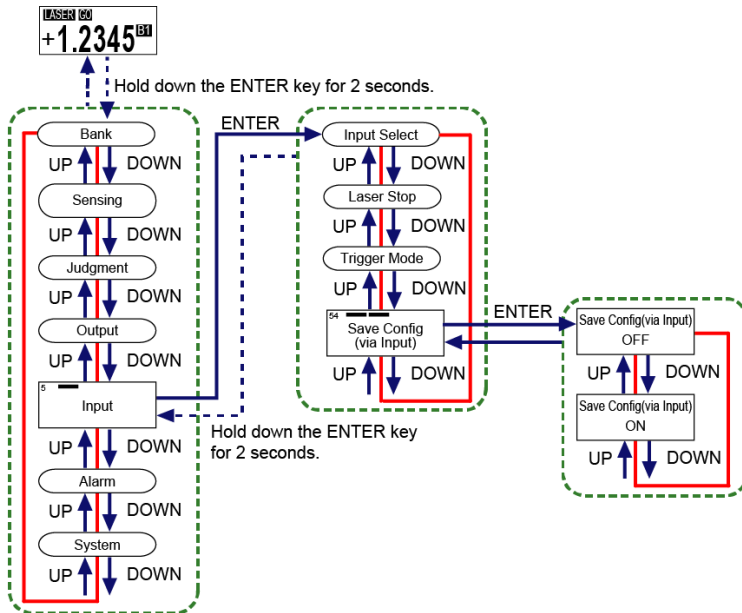

#### ■ Note

- Zero set setting and zero set correction values may be saved by operating switches on this product even when this function is not set to ON.
- Hold down the <ENTER> key for 2 seconds on the setting screen, and the setting change is suspended and the screen returns to the previous display.

Setting item	Set value	Default value
Input line saving setting	OFF	OFF
	ON	



## 4.7 Alarm Setting

### ■ Overview

The alarm setting provides function settings related to data processing in an unmeasurable state.

Unmeasurable state refers to a state where the light receiving waveform of CMOS does not allow for correct calculation of measured values.

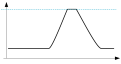
The types of unmeasurable states are as shown below.

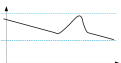
Type of unmeasurable state	Description
Excessive intensity of received light	Intensity of received light is saturated. 
Insufficient intensity of received light	Intensity of received light is insufficient. 
Excessive extraneous light	Extraneous light is excessive. 

## 4.7 Alarm Setting

### 4.7.1 Alarm Delay Count

#### ■ Overview

You will be notified of an alarm if an unmeasurable state is detected. This function allows you to delay the notification until the set sampling count is reached. While an alarm is being delayed, the last measured value is held.

#### ■ Setting method

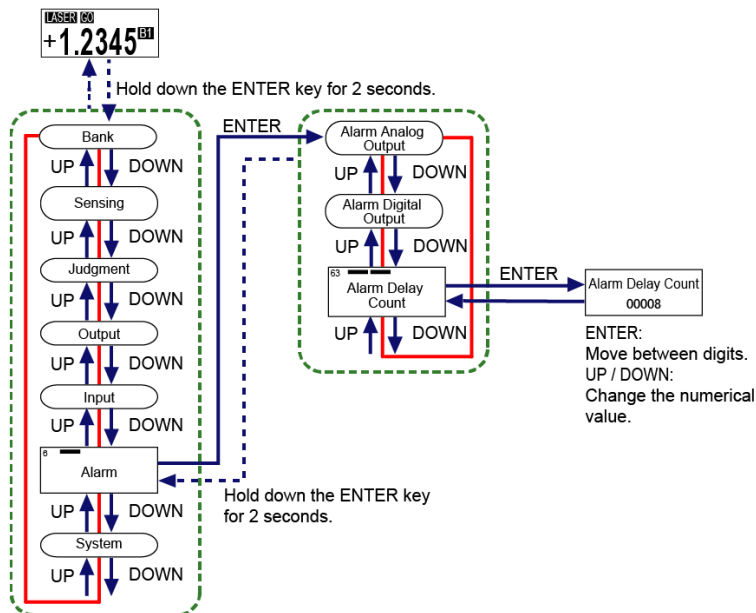

Setting item	Set value	Default value
Alarm delay count	0: Alarm notification OFF	8
	1 to 65535 (times)	

#### 📌 Note

- If you set the alarm delay count to "0", the alarm notification is turned OFF.
- The delay time is calculated by multiplying the alarm delay count by the sampling cycle.
- Simultaneously pressing the <UP> and <DOWN> keys while moving between the digits returns to the first digit.
- Hold down the <ENTER> key for 2 seconds on the setting screen, and the setting change is suspended and the screen returns to the previous display.

**4.7.2 Alarm Analog Output**

■ **Overview**

This function allows you to set the analog output operation (analog output value) at alarm occurrence.

An alarm will be output if an unmeasurable state continues for more than the sampling count set in "4.7.1 Alarm Delay Count".

Set value	Function
Hold	When an alarm occurs, holds the analog output value immediately before the alarm.
Alarm	When an alarm occurs, outputs the fixed value.

**Note**

- The fixed value is 22 mA for current output and 5.3 V for voltage output.
- When "OFF" is selected in Analog Output, Alarm analog output will not be displayed on the Setting mode selection screen.

■ **Setting method**

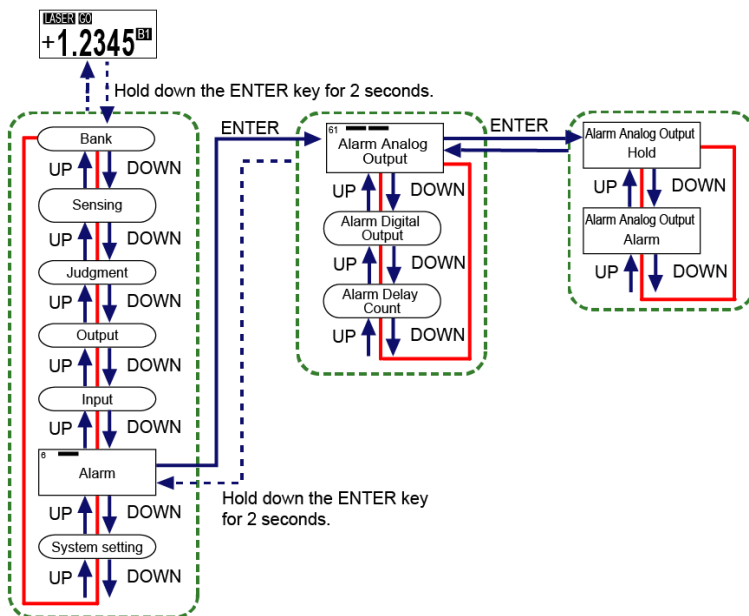

Setting item	Set value	Default value
Alarm analog output	Hold	Hold
	Alarm	

## 4.7 Alarm Setting

---

### Note

- When changing the setting in Alarm analog output, analog output remains OFF or indeterminate state for a fixed period and the output value may not change as set depending on the timing.
- Hold down the <ENTER> key for 2 seconds on the setting screen, and the setting change is suspended and the screen returns to the previous display.

### 4.7.3 Alarm Digital Output

#### ■ Overview

This function allows you to set the digital output operation at alarm occurrence (measured value display, measured value reference by communication).

An alarm will be output if an unmeasurable state continues for more than the sampling count set in "4.7.1 Alarm Delay Count".

Set value	Output result
Hold	The previous measured value will be displayed. <sup>(Note 1)</sup>
Alarm	"ALARM" will be displayed on the display section. When Judgment output is set to other than 3-State, OUT3 of the external outputs is set to ON (when N.O. is selected) or OFF (when N.C. is selected).

(Note 1) If the set value of Alarm digital output is changed in an unmeasurable state, ---- will be displayed continuously on the display section. Clear the unmeasurable state to return to the normal measured value.

#### ■ External output result

Depending on the setting conditions, the states of the external output lines will be as shown below.

#### Output type: Normally open (N.O.)

		Display section	3-value			Logic			Independence			2-value		
			OUT 1	OUT 2	OUT 3	OUT 1	OUT 2	OUT 3	OUT 1	OUT 2	OUT 3	OUT 1	OUT 2	OUT 3
Normal state	HIGH set value < Measured value	Measured value	ON	OFF	OFF	ON	ON	OFF	ON	OFF	OFF	ON	OFF	OFF
	LOW set value ≤ Measured value ≤ HIGH set value	Measured value	OFF	ON	OFF	OFF	ON	OFF	OFF	OFF	OFF	OFF	ON	OFF
	Measured value < LOW set value	Measured value	OFF	OFF	ON	ON	OFF	OFF	OFF	ON	OFF	ON	OFF	OFF
Alarm state	Hold	Previous measured value	Dependent on measured value			Dependent on measured value		ON	Dependent on measured value		ON	Dependent on measured value		ON
	Alarm	ALARM	OFF	OFF	OFF	OFF	OFF	ON	OFF	OFF	ON	OFF	OFF	ON

## 4.7 Alarm Setting

		Display section	3-value			Logic			Independence			2-value		
			OUT 1	OUT 2	OUT 3	OUT 1	OUT 2	OUT 3	OUT 1	OUT 2	OUT 3	OUT 1	OUT 2	OUT 3
Indeterminate state	—	----	OFF	OFF	OFF	OFF	OFF	OFF	OFF	OFF	OFF	OFF	OFF	OFF

### Output type: Normally closed (N.C.)

		Display section	3-value			Logic			Independence			2-value		
			OUT 1	OUT 2	OUT 3	OUT 1	OUT 2	OUT 3	OUT 1	OUT 2	OUT 3	OUT 1	OUT 2	OUT 3
Normal state	HIGH set value < Measured value	Measured value	OFF	ON	ON	OFF	OFF	ON	OFF	ON	ON	OFF	ON	ON
	LOW set value ≤ Measured value ≤ HIGH set value	Measured value	ON	OFF	ON	ON	OFF	ON	ON	ON	ON	ON	OFF	ON
	Measured value < LOW set value	Measured value	ON	ON	OFF	OFF	ON	ON	ON	OFF	ON	OFF	ON	ON
Alarm state	Hold	Previous measured value	Dependent on measured value			Dependent on measured value		OFF	Dependent on measured value		OFF	Dependent on measured value		OFF
	Alarm	ALARM	ON	ON	ON	ON	ON	OFF	ON	ON	OFF	ON	ON	OFF
Indeterminate state	—	----	ON	ON	ON	ON	ON	ON	ON	ON	ON	ON	ON	ON



■ Setting method

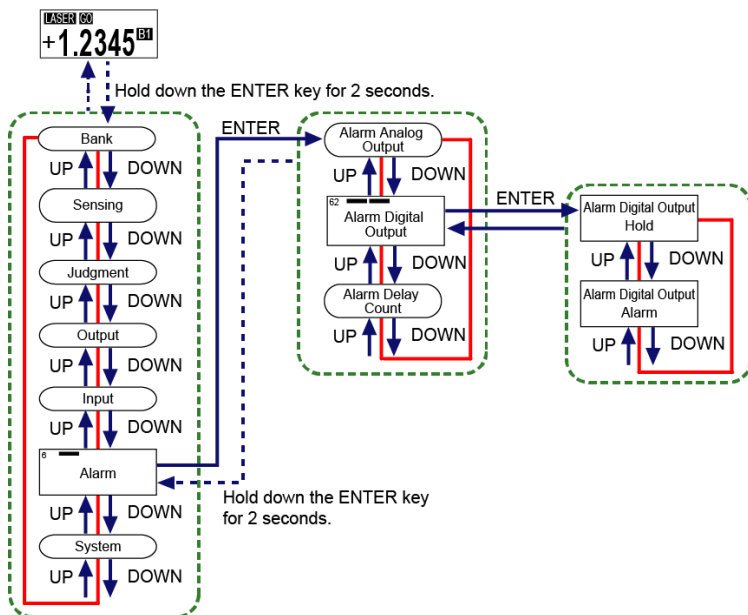

**Note**

- Hold down the <ENTER> key for 2 seconds on the setting screen, and the setting change is suspended and the screen returns to the previous display.

Setting item	Set value	Default value
Alarm digital output	Hold	Hold
	Alarm	

## 4.8 System Setting

### 4.8 System Setting

#### ■ Overview

This is a function setting related to the system settings such as initialization and display language.

#### 4.8.1 Display Digit

#### ■ Overview

This function allows you to switch the number of digits after the decimal point in the digital display.

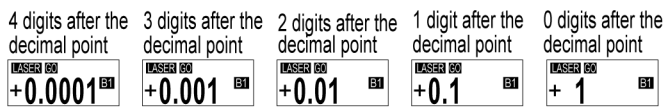

#### ■ Setting method

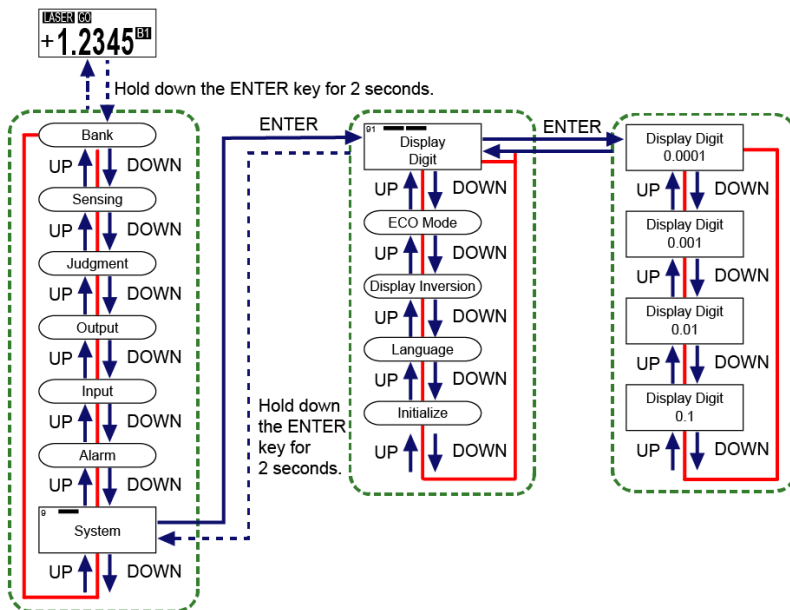

 **Note**

- Any numbers after the specified number of digits displayed are rounded down.
- Teaching may fail or errors may occur in measured value judgment results or calculation results due to the digits after the decimal point that are not displayed depending on the product type or settings.
- This function only applies to measured values that are displayed on the measurement display. It does not apply to the measured values displayed during teaching, HIGH set value / LOW set value, etc.
- Hold down the <ENTER> key for 2 seconds on the setting screen, and the setting change is suspended and the screen returns to the previous display.

Setting item	Distance type	Set value	Default value
Display digit	30 mm	4 digits (0.0001) 3 digits (0.001) 2 digits (0.01) 1 digit (0.1)	4 digits (0.0001)
	50 mm	3 digits (0.001)	3 digits (0.001)
	85 mm	2 digits (0.01)	
	120 mm	1 digit (0.1) 0 digits (1)	
	250 mm	2 digits (0.01) 1 digit (0.1) 0 digits (1)	2 digits (0.01)

## 4.8 System Setting

### 4.8.2 ECO Mode

#### ■ Overview

By setting the Eco mode to ON to turn OFF the display section except when operating the product, you can extend the life of the display section.

If the Eco mode is set to ON, the display section will turn OFF when no key is operated for 180 seconds.

If the Eco mode is set to OFF, the display brightness of the display section will decrease when no key is operated for 180 seconds and then blink every 5 seconds.

If you press any key while the display section is OFF (Eco mode: ON) or the brightness has decreased (Eco mode: OFF), it turns ON again at normal brightness.

#### ■ Setting method

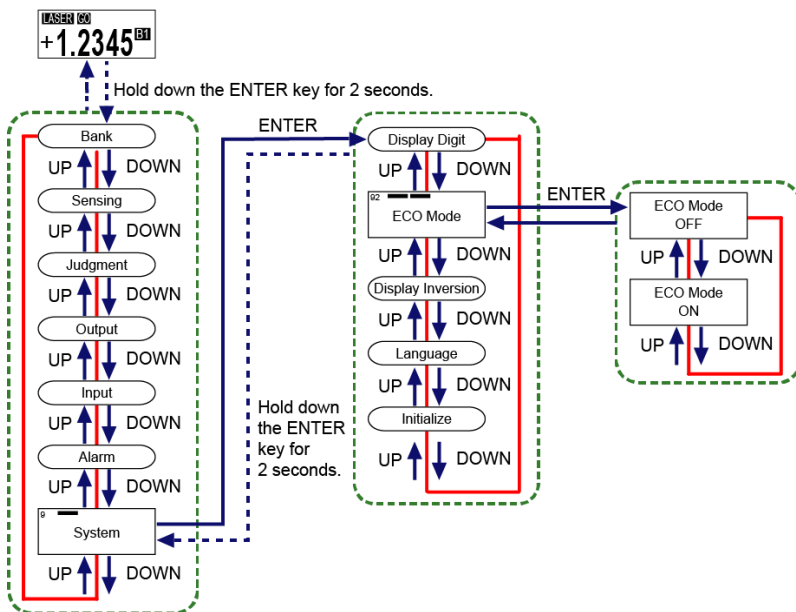

#### 📌 Note

- Hold down the <ENTER> key for 2 seconds on the setting screen, and the setting change is suspended and the screen returns to the previous display.

Setting item	Set value	Default value
ECO mode	OFF	ON
	ON	

### 4.8.3 Display Inversion

#### ■ Overview

The display on the display section is displayed upside down.

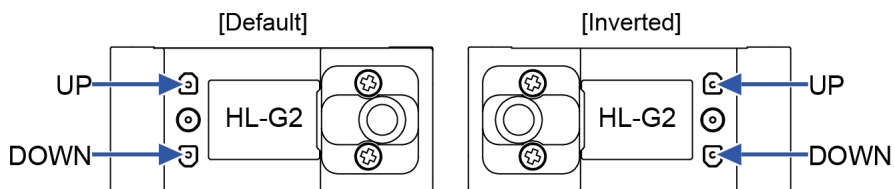

#### ■ Setting method

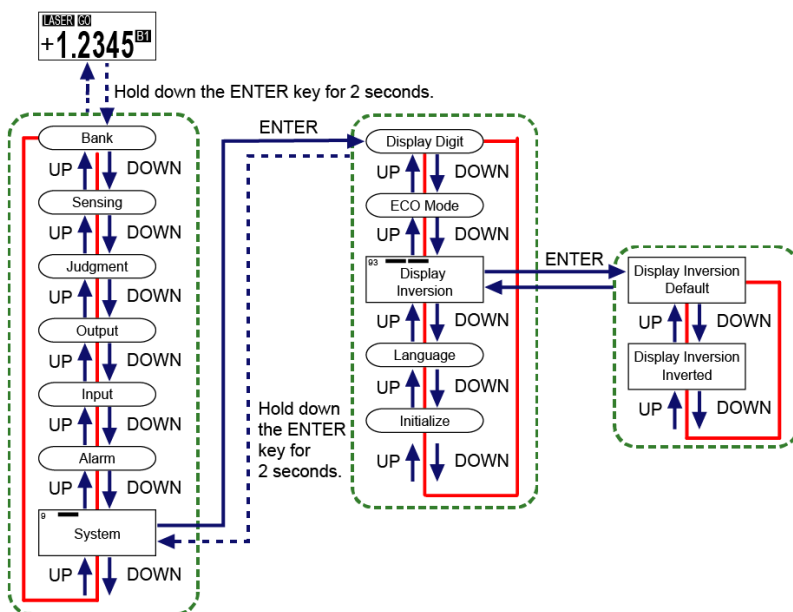

#### 📌 Note

- Hold down the <ENTER> key for 2 seconds on the setting screen, and the setting change is suspended and the screen returns to the previous display.

Setting item	Set value	Default value
Display inversion	Default	Default
	Inverted	

## 4.8 System Setting

### 4.8.4 Language Setting

#### ■ Overview

This function allows you to change the language to be displayed on the display section.

#### ■ Setting method

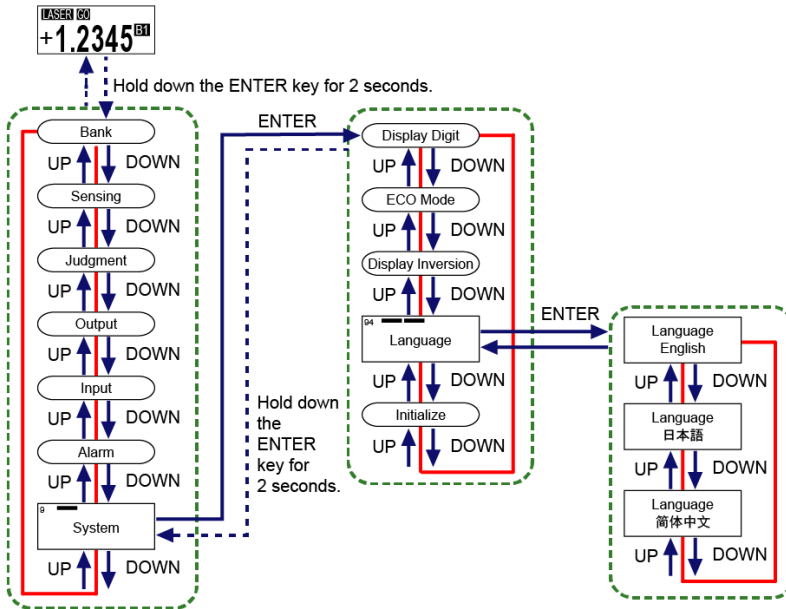

#### ■ Note

- Hold down the <ENTER> key for 2 seconds on the setting screen, and the setting change is suspended and the screen returns to the previous display.

Setting item	Set value	Default value
Language	English	English
	Japanese	
	Simplified Chinese	

### 4.8.5 Settings Initialization

#### ■ Overview

This function allows you to initialize each setting.

Initialization method	Operation
Bank1	Initializes the settings of Bank 1.
Bank2	Initializes the settings of Bank 2.
Bank3	Initializes the settings of Bank 3.
Bank4	Initializes the settings of Bank 4.
All Banks	Initializes the settings of Bank 1 to Bank 4.
All Areas	Initializes all settings except the language setting, NPN/PNP setting, and RS-485/Ethernet communication setting.
Set value initialization	Initializes all settings except RS-485/Ethernet communication setting.

#### ■ Setup method (Bank 1 to Bank 4, All Banks, All Areas)

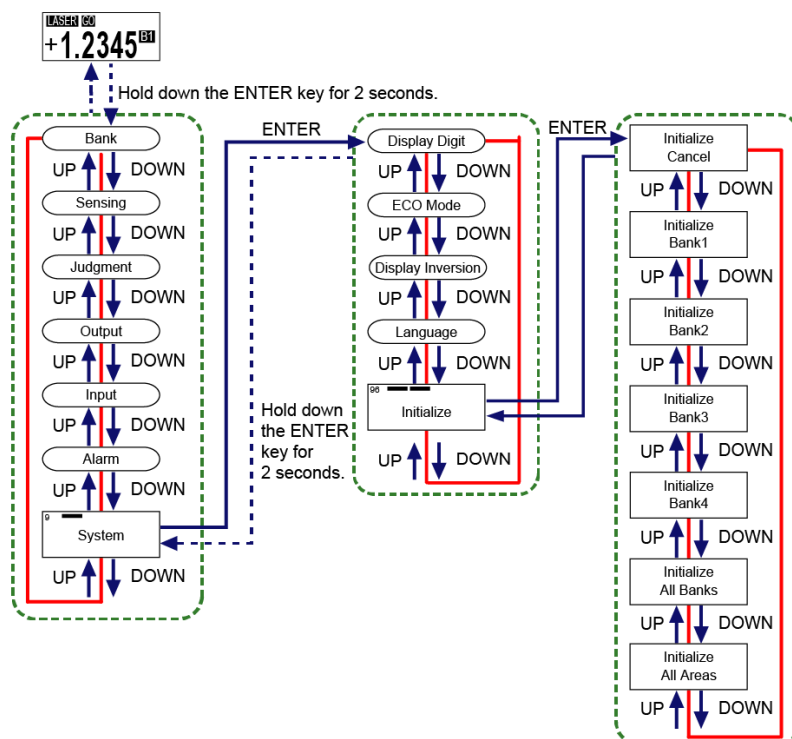

#### Note

- Priority is given to initialization if any key operation or external input is performed while initialization is being executed.
- Hold down the <ENTER> key for 2 seconds on the setting screen, and the setting change is suspended and the screen returns to the previous display.

## 4.8 System Setting

Setting item	Set value	Default value
Initialize	Cancel (No setting)	Cancel
	Bank1	
	Bank2	
	Bank3	
	Bank4	
	All Banks	
	All Areas	

### ■ Setting method (Set value initialization)

To execute Set value initialization, turn on the power while holding down the <ENTER> key for 2 seconds or more.

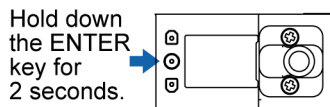

While Set value initialization is being executed, "Initializing" appears for 2 seconds. Then, the display changes to the Language setting screen.

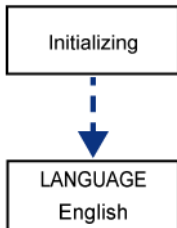



## 4.9 1 point/2 points/3 points Teaching

### ■ Overview

This method is used to set the HIGH set value and LOW set value using one or more sensing objects.



- When performing teaching, it is necessary to set a teaching type in advance. For details on setting the teaching type, refer to "[4.4.4 Teaching Mode](#)".



- In the following case, teaching cannot be started.
  - Hold mode is set to other than "None (Normal mode)".



### Note

- In the following cases, teaching will fail.
  - Alarm state
  - Indeterminate state
  - The measured value is +OVER or -OVER displayed.
  - Hold state (In this case, the state changes to indeterminate state after execution of teaching.)
  - When the measured value is the same at multiple points
  - When the calculated HIGH set value / LOW set value does not meet "(HIGH set value - LOW set value) > hysteresis × 2"
- The HIGH and LOW set values saved in teaching are set according to the setting resolution of the product, where any numbers less than the resolution are internally processed as 0.

Settings	Operation	Reference page
1 point teaching	This method is to perform 1 point teaching on the distance from the reference plane of a sensing object and to set HIGH set value / LOW set value.	<a href="#">"4.9.1 1 point Teaching"</a>
2 points teaching	This method is to perform teaching on the reference planes of two sensing objects and set the HIGH set value / LOW set value based on the measured results.	<a href="#">"4.9.2 2 points Teaching"</a>
3 points teaching	This method is to perform teaching on the reference planes of sensing objects 1, 2, and 3 and set the HIGH set value / LOW set value based on the measured results.	<a href="#">"4.9.3 3 points Teaching"</a>

## 4.9 1 point/2 points/3 points Teaching

### 4.9.1 1 point Teaching

#### ■ Overview

This method is to perform teaching on sensing objects and set the value obtained by adding the tolerance to the teaching result as the HIGH set value and the value obtained by subtracting the tolerance from the teaching result as the LOW set value.



- When performing 1 point teaching, it is necessary to set the tolerance in advance. For details on setting the tolerance, refer to "4.4.5 Tolerance".

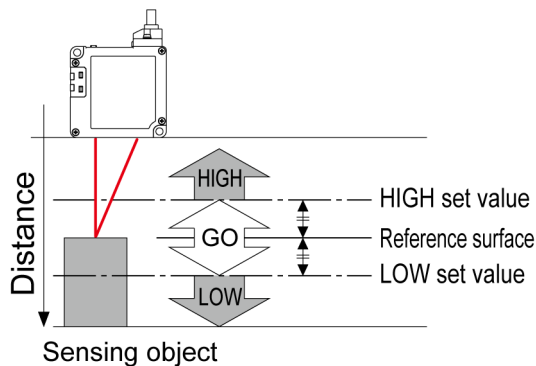

#### ■ Note

- If the value obtained by adding the tolerance to the reference plane exceeds the setting range of the HIGH set value, the HIGH set value is the maximum value in the setting range.
- If the value obtained by subtracting the tolerance from the reference plane falls below the setting range of the LOW set value, the LOW set value is the minimum value in the setting range.

### 1 2 Procedure

1. Set Teaching type to "1 point teaching".
2. On the measurement display, insert the sensing object and hold down the <UP> key for 2 seconds. Confirm that a message saying "Set Target - Push ENTER SW" is displayed at the top of the display. The display changes to the 1st point input screen.

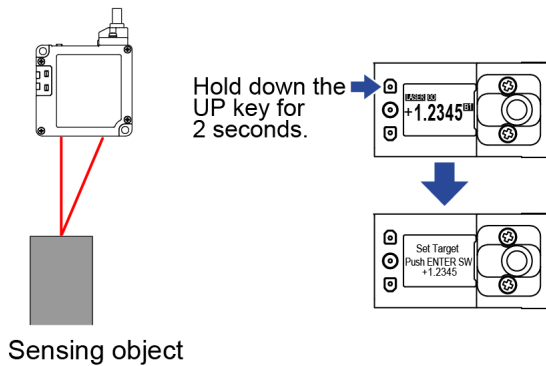

3. Press the<ENTER>key. Teaching will be executed.

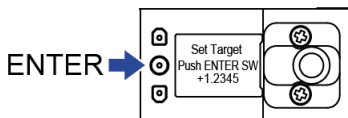

4. When teaching is completed, "Success" is displayed on the display section. Then, the newly set HIGH set value and LOW set value are displayed in sequence, and the display returns to the measurement display.

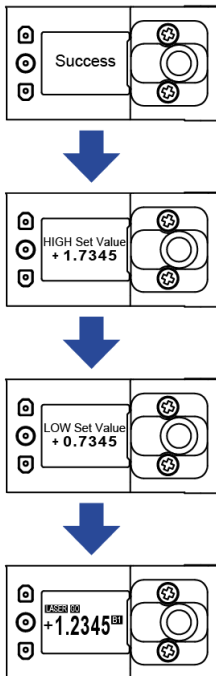

(Note 1) The HIGH set value and LOW set value are those when the tolerance is set to 0.5000.

5. If the measured value is in an alarm state, etc., "Failed" is displayed as the result of teaching. Re-examine positional relationship among the sensing objects and perform teaching again.

## 4.9 1 point/2 points/3 points Teaching

---

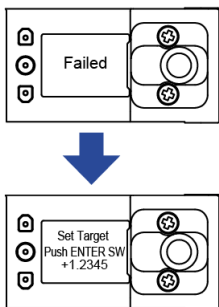

### 1 point teaching using external inputs

---

This section describes how to execute 1-point teaching using external inputs.



- You need to set "Input line operation selection" in advance.  
For how to set "Input line operation selection", refer to ["4.6.1 Input Line Operation Selection"](#).
- Execute teaching on the measurement display.

**1**<sub>2</sub>

#### Procedure

1. With the sensing object inserted, input the "Teaching ON signal" to this product. Teaching will be executed.
2. If teaching is "successful", new HIGH and LOW set values are set. Confirm that the set values have been updated in this product.
3. If teaching "fails", the HIGH and LOW set values remain unchanged.  
Re-examine positional relationship of the sensing object and perform teaching again.

## 4.9.2 2 points Teaching

### ■ Overview

Measure two workpieces and set the higher final measured value to the HIGH set value and the lower final measured value to the LOW set value.

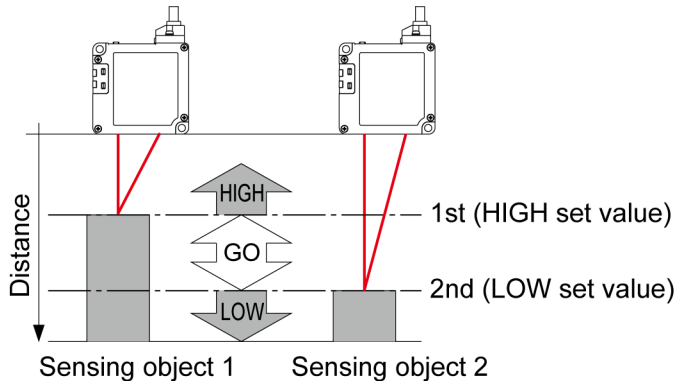

## 1 2 Procedure

1. Set Teaching type to "2 points teaching".
2. On the measurement display, insert the 1st sensing object.
3. With the 1st sensing object inserted, hold down the <UP>key for 2 seconds. Confirm that a message saying "Set 1st Target - Push ENTER SW" is displayed at the top of the display. The display changes to the 1st point input screen.

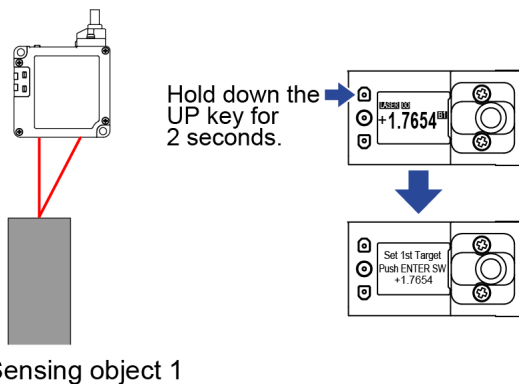

4. Press the <ENTER>key. Teaching for the 1st point is executed.

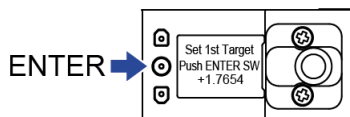

5. Confirm that a message saying "Set 2nd Target and Push ENTER SW" is displayed at the top of the display. The display changes to the 2nd point input screen.

## 4.9 1 point/2 points/3 points Teaching

---

With the 2nd sensing object inserted, press the<ENTER>key. Teaching for the 2nd point is executed.

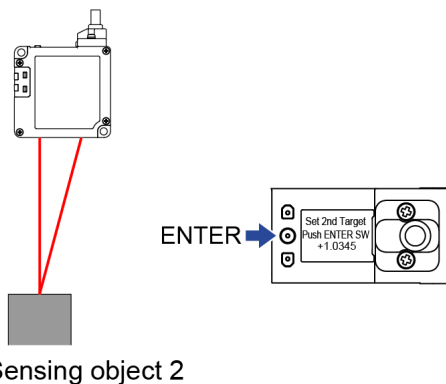

6. When teaching is completed, "Success" is displayed on the display section. Then, the newly set HIGH set value and LOW set value are displayed in sequence, and the display returns to the measurement display.

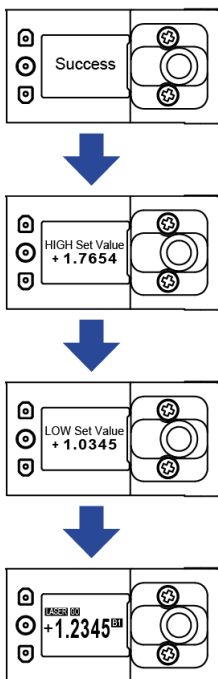

7. If the sensing object is not detected stably, for example, if the 1st and 2nd points have the same measured value, "Failed" will be displayed. Re-examine positional relationship among the sensing objects and perform teaching again.

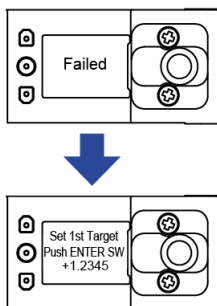

## 2 points teaching using external inputs

This section describes how to execute 2 points teaching using external inputs.



- You need to set "Input line operation selection" in advance.  
For how to set "Input line operation selection", refer to ["4.6.1 Input Line Operation Selection"](#).
- Execute teaching on the measurement display.
- During the execution of teaching using external inputs, operating switches on this product interrupts the teaching operation.

### 1 2

## Procedure

1. With the 1st sensing object inserted, input the "Teaching ON signal" to this product. Teaching for the 1st point is executed.
2. With the 2nd sensing object inserted, input the "Teaching ON signal". Teaching for the 2nd point is executed.
3. If teaching is "successful", new HIGH and LOW set values are set. Confirm that the set values have been updated in this product.
4. If teaching "fails", the HIGH and LOW set values remain unchanged. Re-examine positional relationship between the sensing objects and perform teaching again.

## 4.9 1 point/2 points/3 points Teaching

### 4.9.3 3 points Teaching

#### ■ Overview

This method is to perform teaching on three sensing objects and set the HIGH set value and LOW set value for each of them based on the measured results.

Among the three measured values, the highest value is the maximum value, the second highest value is the median value, and the third highest value is the minimum value. The intermediate value between the highest value and the median value is set as the HIGH set value, and the intermediate value between the lowest value and the median value is set as the LOW set value.

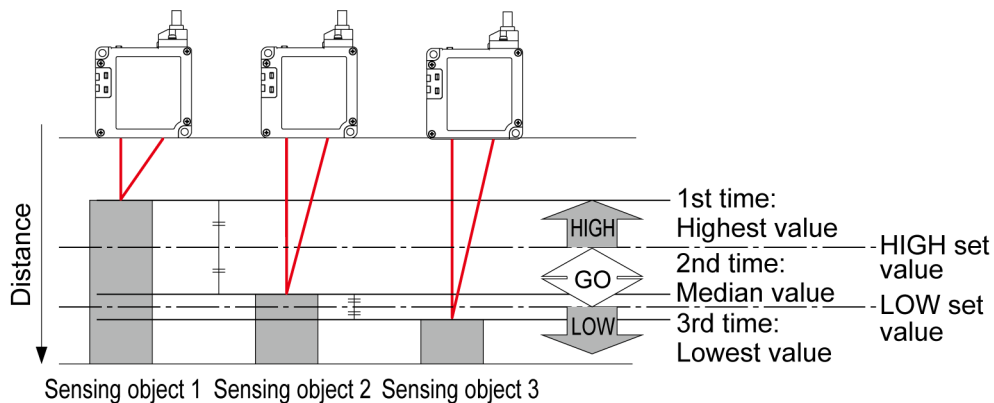

#### 1 2 Procedure

1. Set Teaching type to "3 points teaching".
2. On the measurement display, insert the 1st sensing object.
3. With the 1st sensing object inserted, hold down the <UP> key for 2 seconds. Confirm that a message saying "Set 1st Target - Push ENTER SW" is displayed at the top of the display. The display changes to the 1st point input screen.

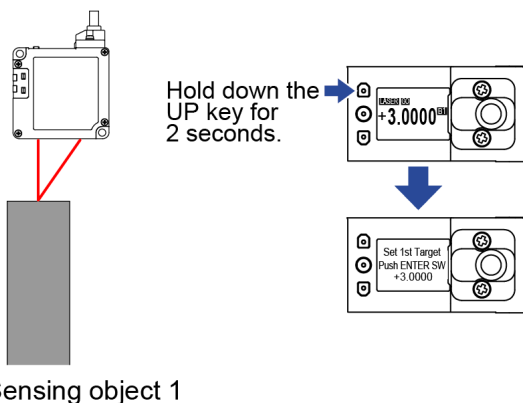

4. Press the <ENTER> key. Teaching for the 1st point is executed.



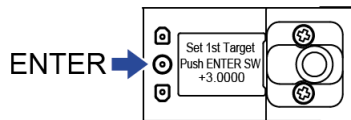

5. Confirm that a message saying "Set 2nd Target and Push ENTER SW" is displayed at the top of the display. The display changes to the 2nd point input screen. With the 2nd sensing object inserted, press the <ENTER> key. Teaching for the 2nd point is executed.

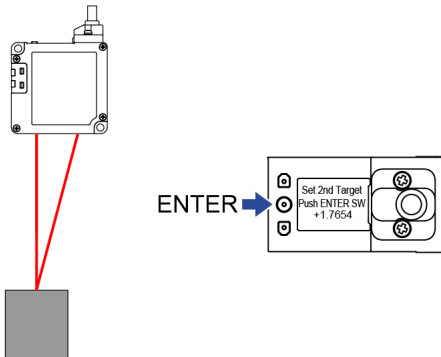

Sensing object 2

6. Confirm that a message saying "Set 3rd Target and Push ENTER SW" is displayed at the top of the display. The display changes to the 3rd point input screen. With the 3rd sensing object inserted, press the <ENTER> key. Teaching for the 3rd point is executed.

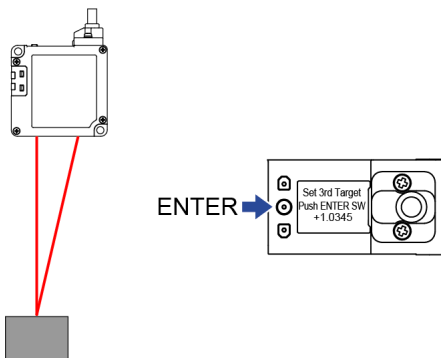

Sensing object 3

7. When teaching is completed, "Success" is displayed on the display section. Then, the newly set HIGH set value and LOW set value are displayed in sequence, and the display returns to the measurement display.

## 4.9 1 point/2 points/3 points Teaching

---

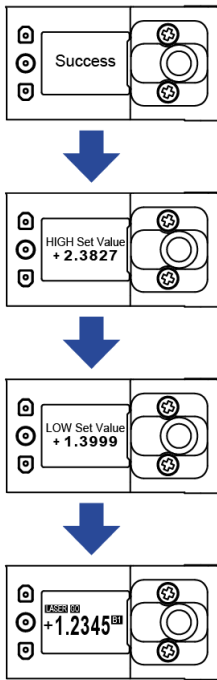

8. If the sensing object is not detected stably, for example, if two or more of the three teaching points have the same measurement value, "Failed" will be displayed. Re-examine positional relationship among the sensing objects and perform teaching again.

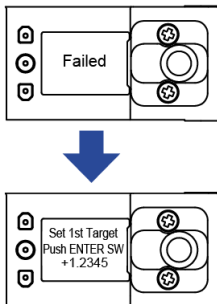

---

### 3 points teaching using external inputs

---

This section describes how to execute 3 points teaching using external inputs.



- You need to set "Input line operation selection" in advance.  
For how to set "Input line operation selection", refer to ["4.6.1 Input Line Operation Selection"](#).
- Execute teaching on the measurement display.
- During the execution of teaching using external inputs, operating switches on this product interrupts the teaching operation.

**1 2**

#### Procedure

1. With the 1st sensing object inserted, input the "Teaching ON signal" to this product. Teaching for the 1st point is executed.
2. With the 2nd sensing object inserted, input the "Teaching ON signal". Teaching for the 2nd point is executed.
3. With the 3rd sensing object inserted, input the "Teaching ON signal". Teaching for the 3rd point is executed.
4. If teaching is "successful", new HIGH and LOW set values are set. Confirm that the set values have been updated in this product.
5. If teaching "fails", the HIGH and LOW set values remain unchanged.  
Re-examine positional relationship among the sensing objects and perform teaching again.

## 4.10 Zero Setting

### 4.10 Zero Setting

#### ■ Overview

This function is used to forcibly set the measured value to "0". You can use the function to adjust the reference point when this product has been replaced or when the workpiece has been changed.

When the zero set is set, the measured value at the location where the setting is executed is set to zero. Depending on where the zero set is set, the display value for the sensing location changes.

#### 1 2 Procedure

1. Simultaneously hold down the <UP> and <DOWN> keys on the measurement display to complete zero setting.

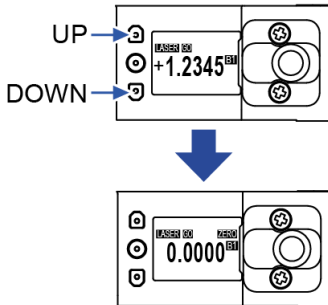

2. Simultaneously hold down the <DOWN> and <ENTER> keys on the measurement display to clear the zero set setting.

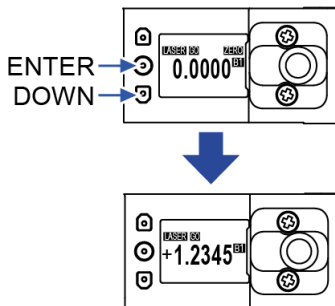

 **Note**

- If you execute Inversion of Measured Value in the state where zero set setting is complete and the measured value is set to 0, the measured value changes from 0. After executing Inversion of Measured Value, make an adjustment again.
- When the light receiving state of CMOS is "unmeasurable", Zero set ON cannot be set. (For information on unmeasurable state, refer to "4.7 Alarm Setting".)
- For whether or not Zero set ON can be set depending on the sensor indication such as "Indeterminate" or "Alarm" state, refer to the table below.

Even if the light receiving state of CMOS is unmeasurable, the measured value may still be displayed on the display due to trigger input or alarm delay. Note that zero set ON cannot be set also in this case.

Sensor display	Light receiving state of CMOS	
	Measurable	Unmeasurable
Normal (Inside the measurement range)	○	×
Normal (Outside the measurement range)	△	×
Alarm	△	×
Indeterminate	△	×

(Note 1) ○: Zero set ON can be set.

△: Zero set ON setting can be set, but is not recommended because the correction value will be indeterminate.

×: Zero set ON cannot be set.

- When zero setting is executed in a state where an offset is set, the measured value is set to the offset value.
- It is possible to execute zero setting using external inputs.  
If you want to retain the settings after the power is turned off, set Save Config to ON.

## 4.11 Measured Value Resetting

### 4.11 Measured Value Resetting

#### ■ Overview

This function is used to reset the moving average data of the measured value or the value held by the hold function.

#### 1 2 Procedure

1. Simultaneously hold down the<UP>and<ENTER>keys on the measurement display to reset the measured value.

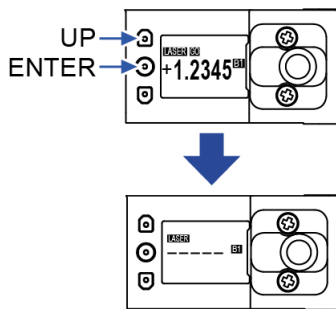

#### ■ Note

- When the resetting function is executed, all the "Judgment output" values are turned OFF.

## 4.12 Key Lock

This function is used to disable key operation to prevent the conditions set in each setting mode from being changed by mistake.

While the key lock setting is activated, all key operations other than key lock release cannot be performed.

### 4.12.1 Key Lock Setting

#### 1 2 Procedure

1. Simultaneously hold down the <UP> and <DOWN> keys on the measurement display for 2 seconds.  
 ""KEY LOCK ON"" is displayed in the display section for 2 seconds to indicate that the setting has been completed.

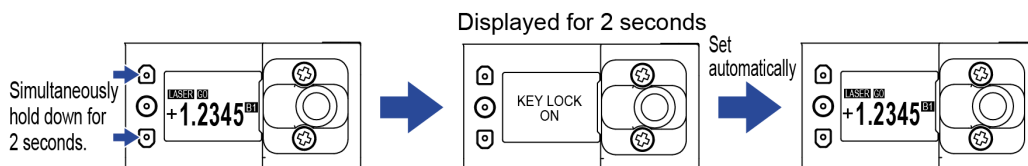

#### Note

- If you perform any key operation while the key lock setting enabled, "KEY LOCK ON" will be displayed on the display section and no key operation will be accepted.

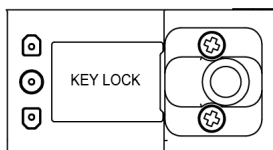

### 4.12.2 Key Lock OFF

#### 1 2 Procedure

1. While the key lock setting is ON, simultaneously hold down the <UP> and <DOWN> keys for 2 seconds.  
 "KEY LOCK OFF" is displayed on the display section for 2 seconds and the key lock is released.

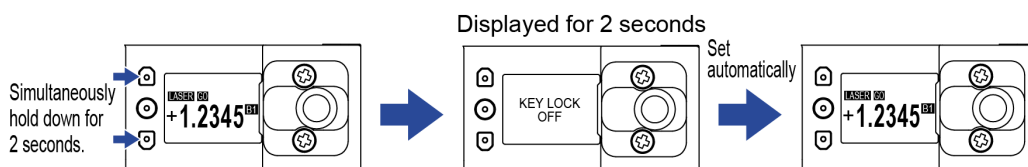

(MEMO)



# 5 Maintenance

---

5.1 Maintenance and Inspection .....	5-2
5.1.1 Maintenance Precautions .....	5-2
5.1.2 Main Inspection Items .....	5-2

## 5.1 Maintenance and Inspection

---

### 5.1 Maintenance and Inspection

#### 5.1.1 Maintenance Precautions

- When cleaning, be sure to turn off the power supply to do cleaning while the laser radiation is stopped.
- Never use thinner, benzene, or other organic solvents to wipe off dirt or dust because some parts are resin-molded.
- Avoid wiping the front cover of laser opening with force. Doing so may damage the front cover to cause an error.
- The light emitting and receiving surfaces of the sensor head must be free of oil, fingerprints, and other substances that refract light as well as dust, grit, and other objects that intercept light. Otherwise, it will cause an error. Regularly perform inspection and keep it clean.
- Remove large dust or grit particles using a blower for camera lens.
- Wipe off small dust or stains like fingerprints with a soft lens cleaner or lens cleaning paper.

#### 5.1.2 Main Inspection Items

Inspect the sensor regularly to maintain performance and enable optimum use.

The main inspection items are as follows:

- Is the connection of each input and output line loose or disconnected?
- Is the front cover for the laser opening of the sensor head stained with dust, grit, fingerprints, etc.?
- Is the supplied power within the rated voltage range (21.6 V to 26.4 V)?
- Is the ambient temperature within the specified range (sensor head: -10 °C to +45 °C)?
- Is the ambient humidity within the specified range (35% to 85% RH)?

# 6 Troubleshooting

---

6.1 Solutions to Problems .....	6-2
6.2 Error Messages and Action Methods.....	6-4

## 6.1 Solutions to Problems

### 6.1 Solutions to Problems

Solutions to frequently encountered problems and errors are described below.

**Note**

- Check the wiring.
- Check if the NPN/PNP setting is correct.
- Check the voltage and capacity of the power supply.

Symptom	Cause	Action method	Reference page
Nothing is displayed on the display section.	Power is not supplied.	Check if the capacity of the power supply is sufficient. Connect the power supply correctly.	"7.1 Specifications"
	The ECO Mode is set to ON.	Set Eco mode to OFF.	"4.8.2 ECO Mode"
No laser is emitted.	Laser stop setting is saved in the ON state.	If the laser stop setting is saved in the ON state, the system is started with the laser stopped. Set it to OFF.	"4.6.2 Laser Stop"
Expected measured values are not output.	The sensing objects are not within the measurement range.	Check if the sensing objects are within the measurement range.	-
	Obstacles exist within the measurement range.	Remove the obstacles.	-
	The hold function is ON.	Check the settings of the hold function.	"4.3.4 Hold Mode"
	The distance between this product and the sensing objects is too far.	Ensure that the distance between this product and the sensing objects is within the specified range.	"3.3 Sensor Installation Direction and Angle"
	The span adjustment and analog scaling settings are not set correctly.	Perform span adjustment and analog scaling in the actual installation conditions.	"4.3.6 Span" "4.5.6 Analog Scaling"
	Dust, dirt, or other foreign matter adhered to the beam emitting and receiving parts of this product.	With a lint-free soft cloth or lens cleaning paper, wipe off any dirt that adhered to the beam emitting and receiving parts of this product.	-
	Dust, dirt, or other foreign matter adhered to the sensing objects.	Remove any dust, dirt, or other foreign matter that adheres to the sensing object.	-
	Dust, grit, or other substances are attached to the operating environment.	Use a dust collector or similar device to remove and prevent dust, grit, and other substances from flying in the operating environment.	-
	The distance between this product and the sensing objects is too far.	Ensure that the distance between this product and the sensing objects is within the specified range.	"7.1 Specifications"
Expected analog current or voltage is not output.	Analog output line is not wired correctly.	Wire the analog output line correctly.	"3.5 Functions and"

Symptom	Cause	Action method	Reference page
	Analog scaling is not set correctly.	Set analog scaling correctly.	Wiring of I/O Lines" "4.5.6 Analog Scaling"
Measured values are not stable.	This product is installed in a location subject to severe vibration.	Take measures against vibration.	-
Alarm indicator is lit and measurement cannot be performed. (Refer also to "Expected measured values are not output".)	The intensity of received light is judged to be insufficient because it exceeds the adjustment range.	Increase the sampling cycle.	"4.3.1 Sampling Frequency" "4.7 Alarm Setting"
	The intensity of received light is judged to be excessive because it exceeds the adjustment range.	Make sure that this product and the sensing objects are facing each other to prevent specularly reflected light beams from entering the beam receiving part.	"4.7 Alarm Setting"
	Extraneous light is judged to be excessive.	Re-examine the measurement environment to ensure that the level of sunlight and other extraneous light is low.	"4.7 Alarm Setting"
Keys cannot be operated	The key lock function is ON.	Set the key lock function to OFF.	"4.12 Key Lock"



- If the product still does not operate normally after you check the above, contact our office.

## 6.2 Error Messages and Action Methods

### 6.2 Error Messages and Action Methods

If an error occurs during setting or measurement, one of the error codes listed below will be displayed on the display section.

Error code	Description	Action method
E100**	Dark level adjustment error	Install the sensor so that strong light or fluctuating light does not enter the sensor, and turn the power OFF and then ON.
E120**	CPU error	Turn the power OFF and then ON.
E130**	Internal memory access error (system area)	Turn the power OFF and then ON.
E131**	Internal memory access error (user area)	Refer to "4.8.5 Settings Initialization" and execute Set value initialization.
E140**	Internal access error	Turn the power OFF and then ON.
E150**	Start processing error	Turn the power OFF and then ON.
E200**	Beam-emitting circuit error	We recommend that the sensor be replaced.
E211** E212** E213**	Overcurrent detection error	Turn OFF the power and check the load.

(Note 1) Internal information is set in the last two digits ("\*\*") of each error code.



- When an error has occurred, check whether the sensor is subject to excessive vibration.
- If the product still does not operate normally after you cleared the above, contact our office.

# 7 Specifications and Dimensions

---

7.1 Specifications.....	7-2
7.1.1 Beam Diameter .....	7-5
7.1.2 Mutual Interference Area .....	7-6
7.2 Shapes and Dimensions .....	7-10
7.2.1 Product.....	7-10
7.2.2 Optional Cable .....	7-11
7.2.3 Optional Cable Installation Diagram .....	7-12

## 7.1 Specifications

### 7.1 Specifications

Model name		HL-G203B-A-MK	HL-G205B-A-MK	HL-G208B-A-MK	HL-G212B-A-MK	HL-G225B-A-MK
Measurement center distance		30 mm	50 mm	85 mm	120 mm	250 mm
Measurement range		±5 mm	±10 mm	±20 mm	±30 mm	±150 mm
Beam diameter <sup>(Note 2)</sup> (Note 3)		X axis: approx. 40 μm Y axis: approx. 1,000 μm	X axis: approx. 60 μm Y axis: approx. 2,000 μm	X axis: approx. 90 μm Y axis: approx. 3,000 μm	X axis: approx. 100 μm Y axis: approx. 4,000 μm	X axis: approx. 300 μm Y axis: approx. 8,000 μm
Resolution		0.5 μm	1.5 μm	2.5 μm	4 μm	15 μm
Linearity	Limited range	±0.05 % F.S. (27.5 mm to 32.5 mm)	±0.05 % F.S. (45 mm to 55 mm)	±0.05 % F.S. (75 mm to 95 mm)	±0.05 % F.S. (105 mm to 135 mm)	±0.15 % F.S. (200 mm to 300 mm)
	Other than above	±0.075 % F.S.	±0.075 % F.S.	±0.075 % F.S.	±0.075 % F.S.	±0.25 % F.S.
Temperature characteristics		0.03 % F.S./°C				
Measuring method		Diffuse reflection				
Light source		Red semiconductor laser: Class 2 (IEC/EN/JIS/GB/FDA Laser Notice No. 56 <sup>(Note 4)</sup> ) Maximum output: 1 mW, Peak emission wavelength: 655 nm				
Light receiving element		CMOS image sensor				
Power supply voltage		Power supply units with a current capacity of 500 mA or more, including 24 VDC ±10%, ripple 0.5 V (P-P)				
Current consumption		150 mA or less <sup>(Note 5)</sup>				
Sampling cycle		100 μs, 200 μs, 500 μs, 1 ms, 2 ms				
Analog output		Output mode switchable by changing the setting				
			<b>When voltage output is selected</b>	<b>When current output is selected</b>		
		Output scale (Default value)	0 V to 5 V / F.S.	4 mA to 20 mA / F.S.		
		Normal output range	0 V to 5.25 V	3.2 mA to 20.8 mA		
		Alarm †1	5.3 V ±20 mV	22 mA ±100 μA		
		Indeterminate state	5.5 V ±20 mV	23 mA ±100 μA		
		Impedance	Output impedance 100 Ω	Load impedance 300 Ω or less		
		Resolution †2	±2 mV	±6 μA		
		Linearity †3	±0.05 % F.S.	±0.25 % F.S.		
		Temperature characteristics	0.005 % F.S./°C	0.01 % F.S./°C		
		†1 The value that will be output when Alarm analog output is set to Alarm. When set to Hold, the value immediately before alarm occurrence will be held.				



Model name	HL-G203B-A-MK	HL-G205B-A-MK	HL-G208B-A-MK	HL-G212B-A-MK	HL-G225B-A-MK
	†2 This refers to the repeatability of analog output only. Static resolution and linearity error by measurement will be added. †3 This refers to the linearity of analog output only. Static resolution and linearity error by measurement will be added. This does not include the repeatability of analog output only.				
Control output	OUT 1 OUT 2 OUT 3	<ul style="list-style-type: none"> <li>• Possible to switch over between NPN transistor open collector / PNP transistor open collector by changing the setting</li> <li>• Possible to switch over between judgment output and alarm output by changing the setting</li> </ul> <p><b>When NPN output is selected</b></p> <ul style="list-style-type: none"> <li>• Maximum sink current: 50 mA</li> <li>• Applied voltage: 26.4 VDC or less (between output and 0 V)</li> <li>• Residual voltage: 2 V or less (at 50 mA inflow current)</li> <li>• Leakage current: 0.1 mA or less</li> </ul> <p><b>When PNP output is selected</b></p> <ul style="list-style-type: none"> <li>• Maximum outflow current: 50 mA</li> <li>• Residual voltage: 2.8 V or less (at 50 mA outflow current)</li> <li>• Leakage current: 0.1 mA or less</li> </ul>			
	Output type	Possible to switch over between open and close when set to ON by changing the setting			
	Short-circuit protection	Equipped (Automatic recovery type) * This is not an overcurrent protection.			
External input	IN 1 IN 2 IN 3	<ul style="list-style-type: none"> <li>• Possible to switch over from trigger, zero setting, measured value resetting, laser stop, teaching, or bank by changing the setting</li> <li>• The input conditions are interlocked with NPN/PNP setting of the control output</li> </ul> <p><b>When NPN output is selected</b></p> <ul style="list-style-type: none"> <li>• Source current: approx. 1.5 mA</li> <li>• Input conditions Invalid: 3 to 26.4 VDC or open Valid: 0 to 1.5 VDC</li> </ul> <p><b>When PNP output is selected</b></p> <ul style="list-style-type: none"> <li>• Sink current: approx. 2.5 mA</li> <li>• Input conditions Invalid: 0 to 11 VDC or when released Valid: 19 to 26.4 VDC</li> </ul>			
	Laser radiation	Lit while laser beams are being emitted (Green LED)			
Indicators	Alarm	Lit if measurement is not possible due to insufficient or excessive received light intensity, or excessive extraneous light (Orange LED)			
Display section	0.9 inch organic EL Measured value: signed 5-digit (maximum of 4 digits after the decimal point)				
Degree of protection	IP67				
Pollution degree	2				
Grounding method	Capacitor grounding				

## 7.1 Specifications

Model name	HL-G203B-A-MK	HL-G205B-A-MK	HL-G208B-A-MK	HL-G212B-A-MK	HL-G225B-A-MK
Insulation resistance	20 MΩ or higher, using 500 VDC megger				
Vibration resistance	Durability: 10 to 55 Hz (cycle: 1 minute) with 1.5 mm amplitude in X, Y, and Z directions for 2 hours each				
Shock resistance	500 m/s <sup>2</sup> (approx. 50 G) in X, Y, and Z directions three times each				
Ambient operating illuminance Incandescent lamp	3,000 lx or less (illuminance on the light receiving surface)				
Ambient operating temperature	-10 °C to +45 °C (No icing) During storage: -20 °C to +60 °C (No icing)				
Ambient operating humidity	35 % to 85 % (No condensation) During storage: 35 % to 85 % (No condensation)				
Operating altitude <sup>(Note 6)</sup>	2,000 m or less				
Materials	Product casing: Aluminum die casting, Front cover: Glass, Cable: PVC				
Optional cable	CN-8A-C□ (Analog output type)				
Weight	Product only: approx. 150 g, including packaging: approx. 200 g				

(Note 1) Unless otherwise specified, the above specifications are typical values measured under the following measurement conditions. They do not guarantee performance for all target objects.

Power supply voltage: 24 VDC, ambient temperature: 20 °C, sampling cycle: 1 ms, average count: 512 times, measurement center distance, target object: visible light shielding ceramic

(Note 2) The X and Y axes of the beam diameter are specified as shown in the figure below.

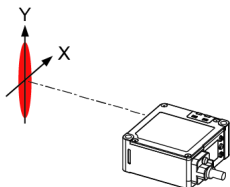

(Note 3) The beam diameter is defined as  $1/e^2$  (approx. 13.5 %) of the center light intensity. Due to leak light outside the defined range, the measurement values may be affected if the reflectance around the detecting point is higher than that of the detecting point.

(Note 4) This product complies with the FDA regulations (FDA 21 CFR 1040.10 and 1040.11) in accordance with FDA Laser Notice No. 56, except for complying with IEC 60825-1 Ed. 3.

(Note 5) Current consumption of the sensor only. External I/O and analog output current are not included.

(Note 6) Do not use or store this product in environments where ambient air is pressurized to an air pressure higher than the atmospheric pressure at an altitude of 0 m.

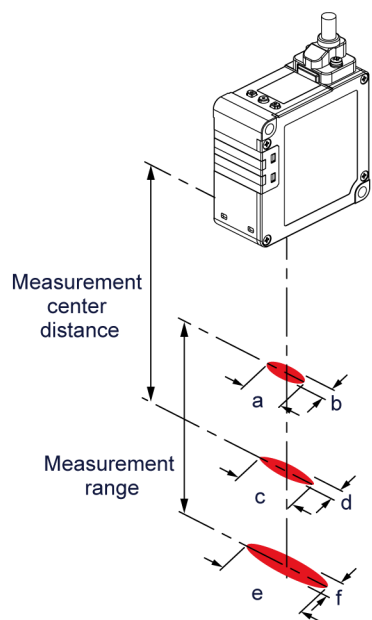

## 7.1.1 Beam Diameter



Model name	Beam diameter (Unit: mm)					
	a	b	c	d	e	f
HL-G203B-A-MK	0.7	0.1	1.0	0.04	1.3	0.1
HL-G205B-A-MK	1.2	0.2	2.0	0.06	2.8	0.2
HL-G208B-A-MK	2.0	0.3	3.0	0.09	4.0	0.2
HL-G212B-A-MK	2.8	0.3	4.0	0.1	5.2	0.3
HL-G225B-A-MK	2.5	0.7	8.0	0.3	13.5	0.5

## 7.1 Specifications

### 7.1.2 Mutual Interference Area

When two or more units of this product are installed side by side, no mutual interference will occur as long as the laser spots of the other units are outside the shaded area  shown in the figure below. Install the product so that the laser spots of other products do not fall within the range of the shaded area .

#### ■ 30 mm type (HL-G203B-A-MK)

Unit: mm

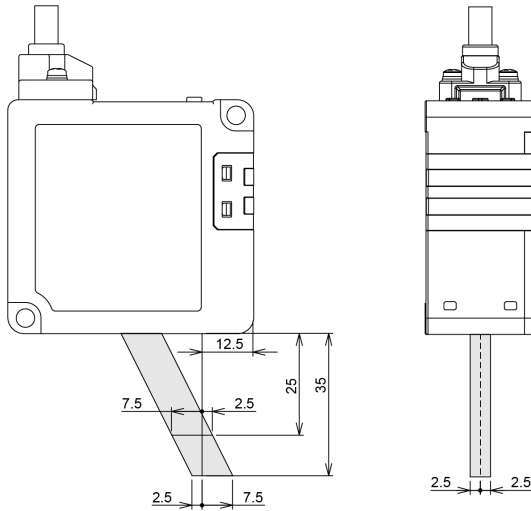

#### ■ 50 mm type (HL-G205B-A-MK)

Unit: mm

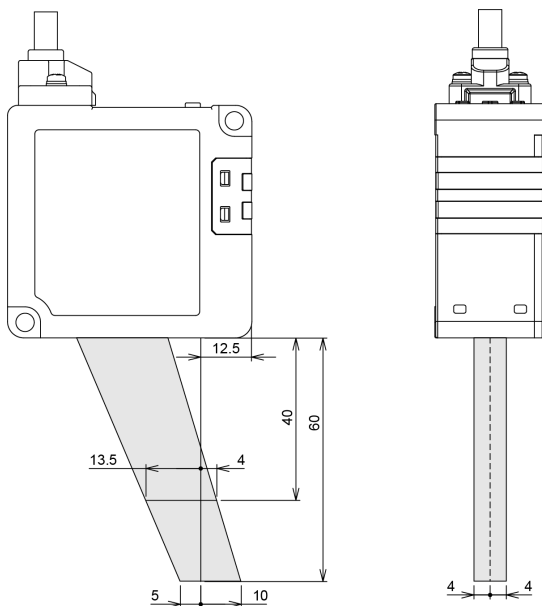

■ 85 mm type (HL-G208B-A-MK)

Unit: mm

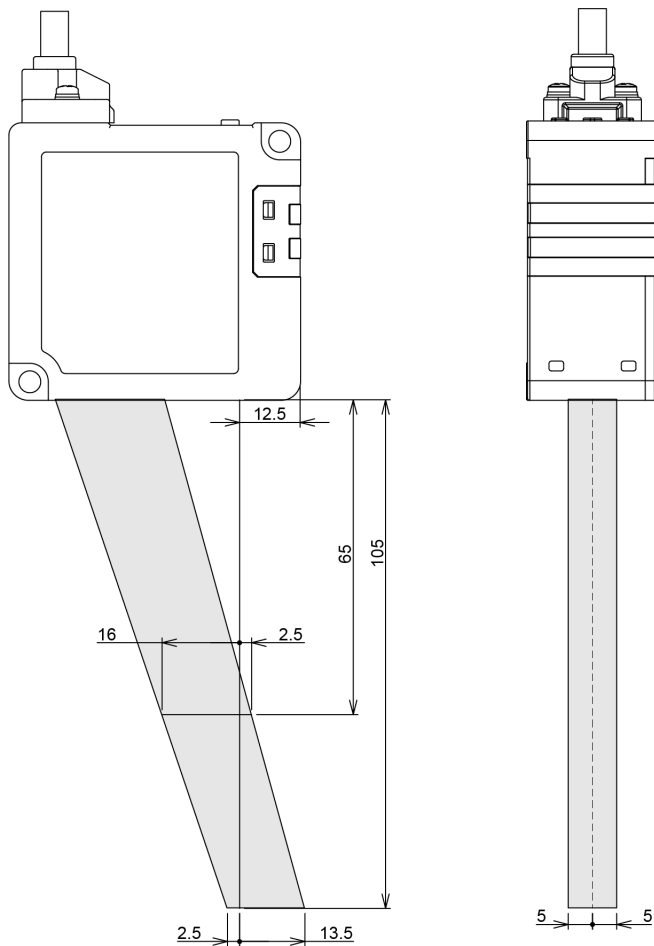

## 7.1 Specifications

---

### ■ 120 mm type (HL-G212B-A-MK)

Unit: mm

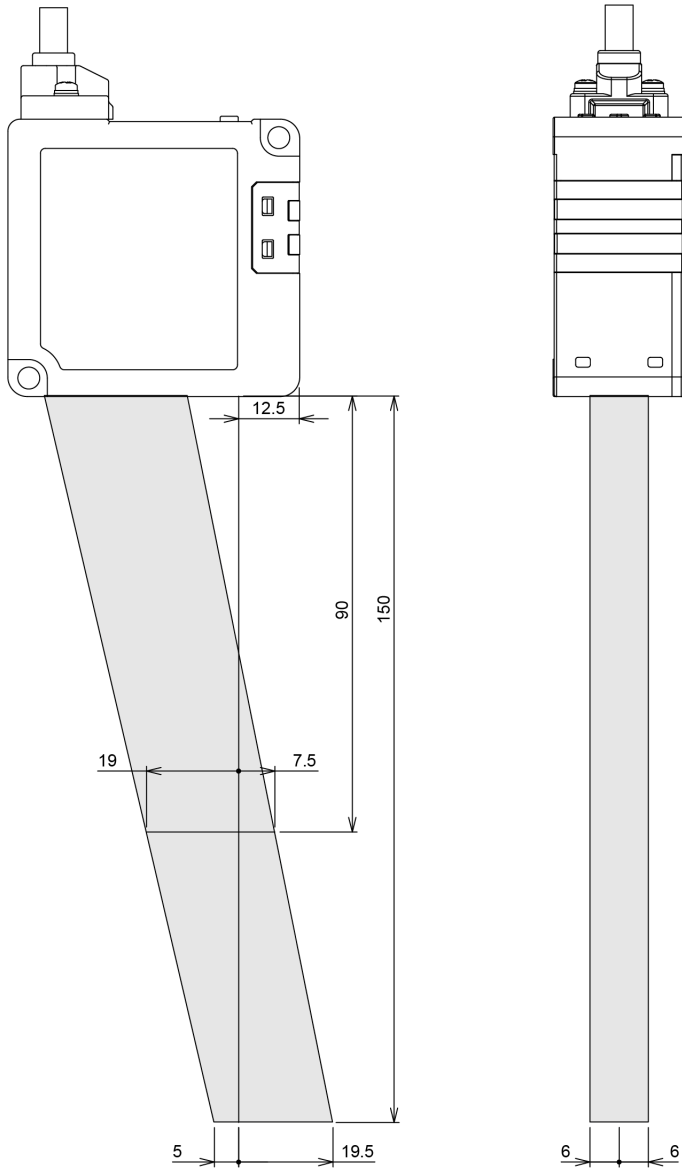

■ 250 mm type (HL-G225B-A-MK)

Unit: mm

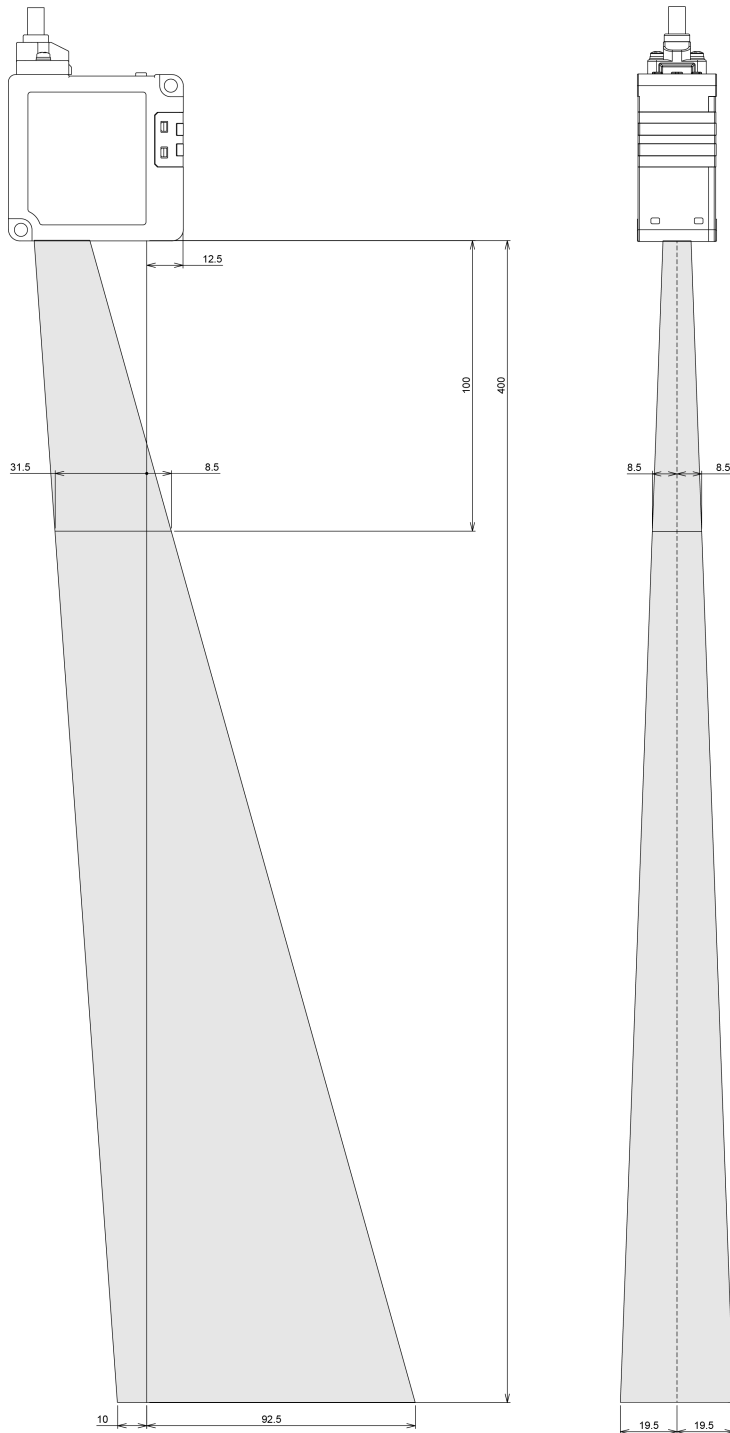

## 7.2 Shapes and Dimensions

### 7.2 Shapes and Dimensions

#### 7.2.1 Product

##### HL-G2□□B-A-MK

Unit: mm

Model name	Measurement center distance (L)	$\theta$
HL-G203B-S-MK	30 mm	30 °
HL-G205B-S-MK	50 mm	24 °
HL-G208B-S-MK	85 mm	17 °
HL-G212B-S-MK	120 mm	13 °
HL-G225B-S-MK	250 mm	6.5 °

TOLERANCE	
6 AND UNDER	±0.3
OVER 6 TO 30 INCL.	±0.4
OVER 30 TO 120 INCL.	±0.8
OVER 120 TO 315 INCL.	±1.2
OVER 315 TO 630 INCL.	±1.8
OVER 630 TO 1000 INCL.	±2.5

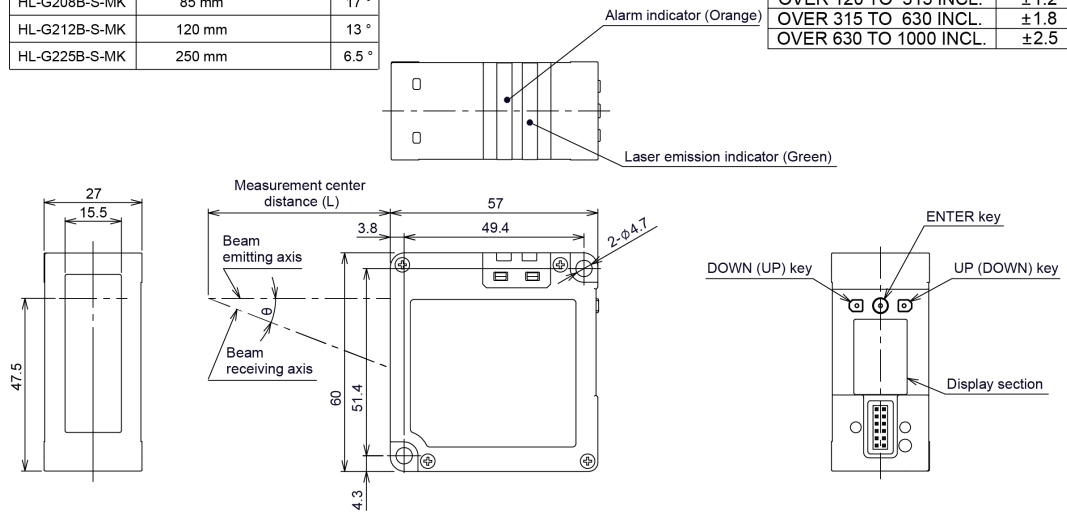



**7.2.2 Optional Cable**

**CN-8A-C□ (Analog output type)**

Unit: mm

Model name	Cable length
CN-8A-C2	2 m
CN-8A-C5	5 m

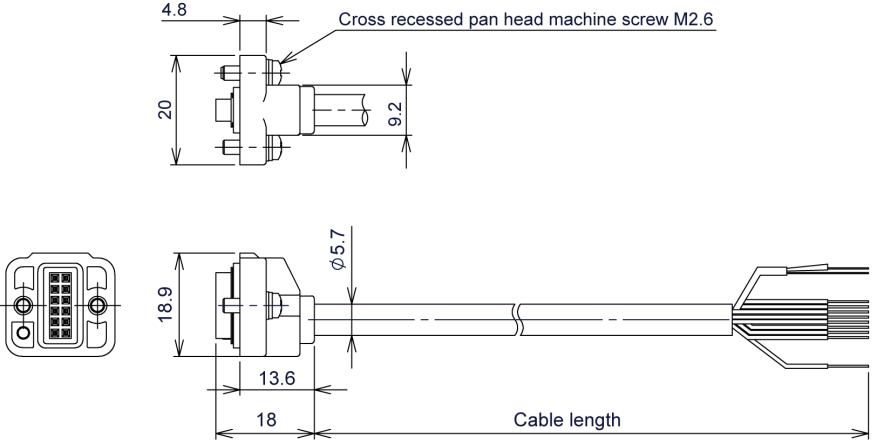

TOLERANCE OF CABLELENGTH	
TOTAL LENGTH	TOLERANGE
1000 OR LESS	+20 % OF TOTAL LENGTH -0
OVER 1000 TO 2000 INCL.	+200 -0
OVER 2000	+20 % OF TOTAL LENGTH -0

TOLERANCE	
6 AND UNDER	±0.3
OVER 6 TO 30 INCL.	±0.4
OVER 30 TO 120 INCL.	±0.8
OVER 120 TO 315 INCL.	±1.2
OVER 315 TO 630 INCL.	±1.8
OVER 630 TO 1000 INCL.	±2.5

## 7.2 Shapes and Dimensions

### 7.2.3 Optional Cable Installation Diagram

Unit: mm

<CN-8A-C□ installed state>

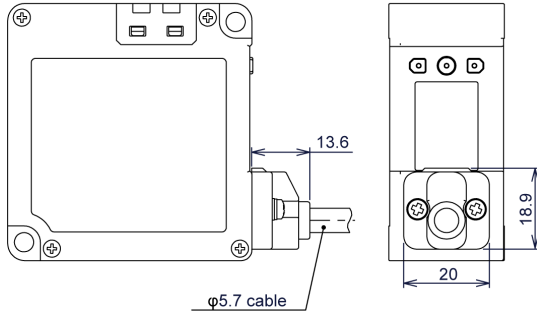

TOLERANCE	
6 AND UNDER	±0.3
OVER 6 TO 30 INCL.	±0.4
OVER 30 TO 120 INCL.	±0.8
OVER 120 TO 315 INCL.	±1.2
OVER 315 TO 630 INCL.	±1.8
OVER 630 TO 1000 INCL.	±2.5

# Appendix Screen Transition List

---

Screen Transition List .....App-2

## Screen Transition List

■ Received light intensity monitor

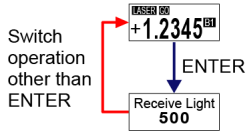

■ HIGH set value setting / LOW set value setting

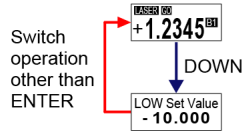
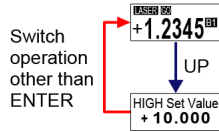

■ 1-point / 2-point / 3-point teaching

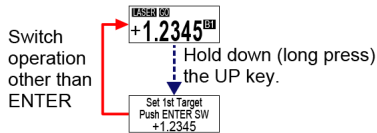

■ Zero setting ON / Zero setting OFF

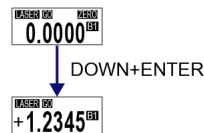
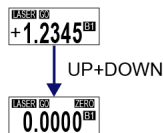

■ Measured value resetting

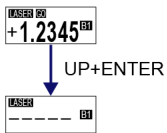

■ Key lock

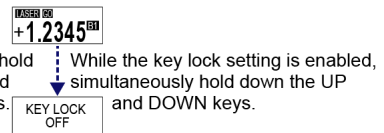
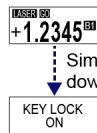

■Setting mode

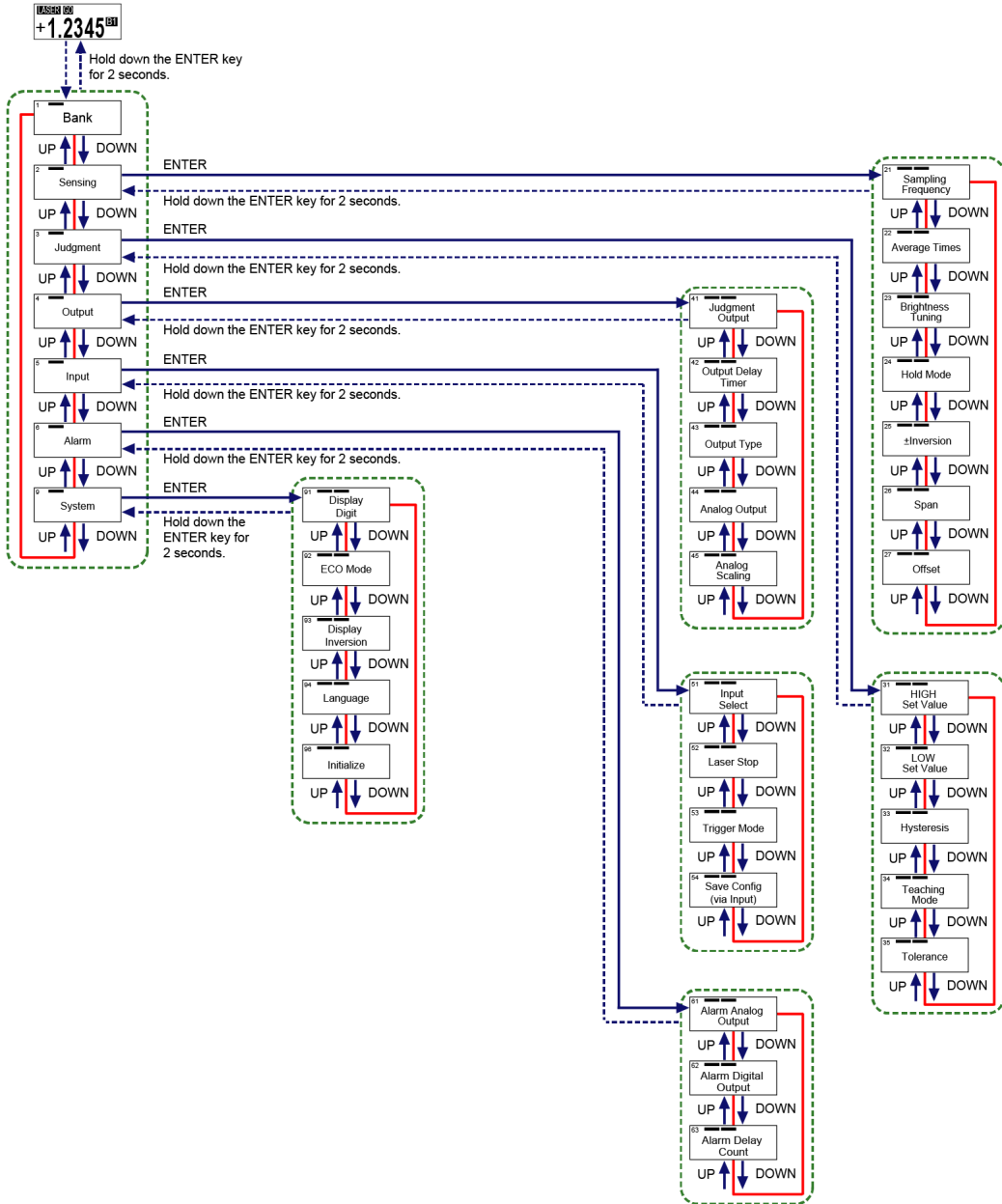

(MEMO)

## Revision History

Revision history	Revision date	Revision item
First edition	January 2024	-

(MEMO)



(MEMO)

---

**Panasonic Industry Co., Ltd.**  
**Panasonic Industrial Devices SUNX Co., Ltd.**  
<https://panasonic.net/id/pidsx/global>

Please visit our website for inquiries and about our sales network.

**Panasonic Industrial Devices SUNX Co., Ltd. 2024**  
January 2024

WUME-HLG2AN-1